

DENON

Hi-Fi Pre-Main Amplifier

Europe Model

SERVICE MANUAL MODEL PMA-540

SOLID STATE
PRE MAIN AMPLIFIER

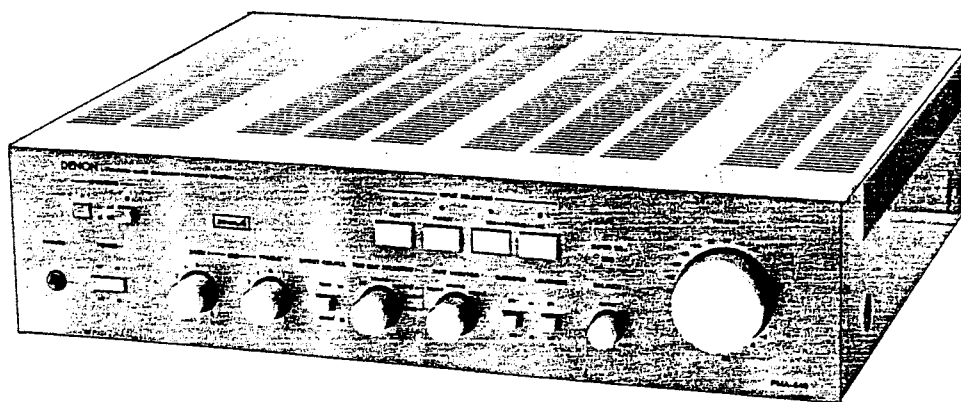

CONTENTS

SPECIFICATIONS	1
BLOCK DIAGRAM	2
METHOD OF ADJUSTMENTS	3
NOTES ON SERVICING REMOTE SWITCH	4
EXPLODED VIEW OF CABINET & CHASSIS	5
EXPLODED VIEW OF PARTS LIST	6
PRINTED CIRCUIT BOARD PATTERNS AND PARTS LIST	
EQ. AMP UNIT AUE-012B.C.D.E.	7~8
TONE & POWER UNIT ETC-404B.C	9~11,14
WIRING DIAGRAM	12
CONNECTION DIAGRAM	13

SPECIFICATIONS

POWER AMPLIFIER SECTION (TUNER → SP OUT)

Rated Output:	Both channels driven
Subject to Change by	
Temperature Test:	20 Hz ~ 20 kHz 80 W + 80 W (DIN, U.K., Europe)
	(8 ohm load) 60 W + 60 W (U.S.A., Canada)
	1 kHz 100 W + 100 W (DIN, U.K., Europe)
	(4 ohm load) 85 W + 85 W (U.S.A., Canada)
	40 W + 40 W (IEC)
Total Harmonic Wave:	Less than 0.007% (20 Hz ~ 20 kHz, at -3 dB rated output 8 ohm load)
	Less than 0.02% (20 Hz ~ 20 kHz, at rated output 8 ohm load) (U.S.A.)
Intermodulation Distortion:	7 kHz/60 Hz : 1/4 at amplitude output equivalent to rated output
	Less than 0.005% (U.K., Europe)
	Less than 0.009% (U.S.A.)
Output Band Width:	4 Hz ~ 100 kHz (IHF, T.H.D 0.1%)
Transmission Characteristics:	1.5 Hz ~ 250 kHz $^{+0}_{-3}$ dB (at 1 W output)
Input Sensitivity:	150 mV
Input Impedance:	40 k ohm
Output Impedance:	0.08 ohm (1 kHz)
SN Ratio (IHFA Network):	106 dB (Input terminals short-circuited)
Output Terminals:	Speaker: A & B load 4 ~ 16 ohm, A + B load 8 ~ 16 ohm; Head-phone/Stereo headphone

EQUALIZER AMPLIFIER SECTION

Equalizer Amplifier Output	
(REC OUT Terminal):	Maximum output 10 V (at 50 k ohm load)
	Rated output 150 mV
	Total harmonic wave distortion: below 0.001% (at 1 kHz, 9 V output)

Input Sensitivity/

Input Impedance:	PHONO MM 2.5 mV 50 k ohm
	MC 250 μ V 100 ohm
	TUNER 150 mV 40 k ohm
	AUX, TAPE 150 mV 40 k ohm
RIAA Deviation:	PHONO MM Within ± 0.2 dB (20 Hz ~ 100kHz)
	MC Within ± 0.2 dB (20 Hz ~ 100kHz)

OVERALL CHARACTERISTICS

SN Ratio (IHA

Network):	PHONO MM 88 dB (Input terminals short-circuited, at 2.5 mV input)
	MC 72 dB (Input terminals short-circuited, at 250 μ V input)
	TUNER, TAPE, AUX over 106 dB (Input terminals short-circuited)

Tone Control Adjustable

Range:	BASS 100 Hz ± 8 dB
	TREBLE 10 kHz ± 8 dB
Filtering Characteristics:	SUBSONIC 18 Hz, 6 dB/oct

Loudness Characteristics:	Low Frequency 100 Hz +7.5 dB
	High Frequency 10 kHz +5.5 dB

AC OUTLET:

(For U.S and Canada)	Not included in systems for European use
	SWITCHED x 2, 100 W (Total)
	UNSWITCHED x 1, 250 W
POWER SOURCE:	Germany and France: AC 220 V, 50 Hz
	U.K.: AC 240 V, 50 Hz
	U.S.A.: AC 120 V, 60 Hz
	Hong Kong: AC 200 V, 50 Hz
POWER CONSUMPTION:	170 W (U.S.A.)
	350 VA (Canada)
	380 W (IEC)
	W (Hong Kong and Singapore)
	620 W Maximum output

DIMENSIONS:

	434 mm (W) x 112 mm (H) x 390 mm (including rubber feet, control knob terminals)
--	--

WEIGHT:

	9.7 kg
--	--------

Design and specifications are subject to change without prior notice.

NOTE: The following codes correspond to the appropriate models.

E2 for Europe EF for France, EK for U.K., E3 for U.S.A., E3 for Canada and E1 for Hong Kong, Singapore.

This Service Manual is prepared based on E1.

BLOCK DIAGRAM

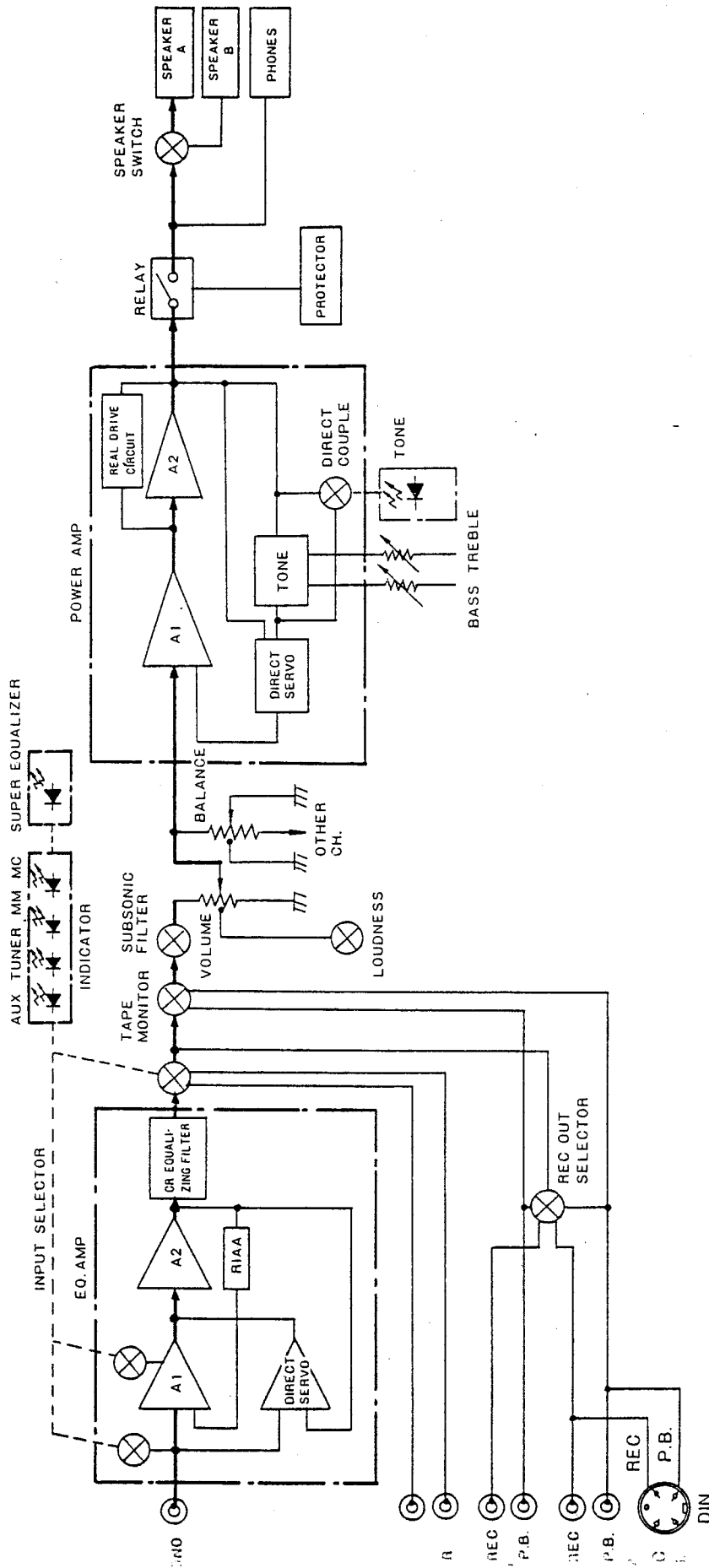

METHOD OF ADJUSTMENT

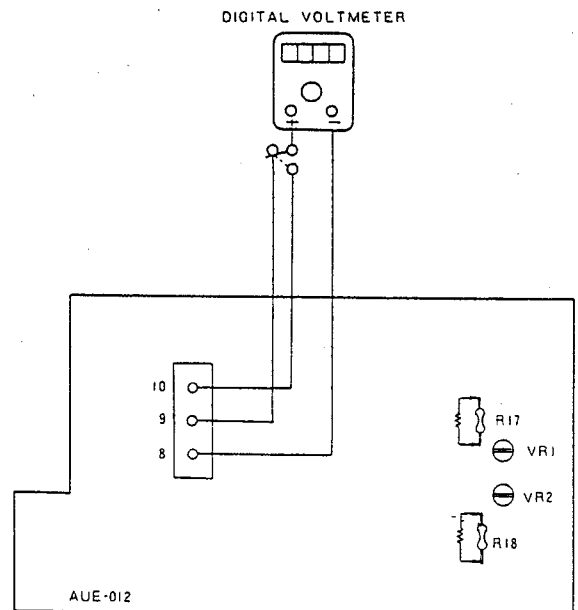
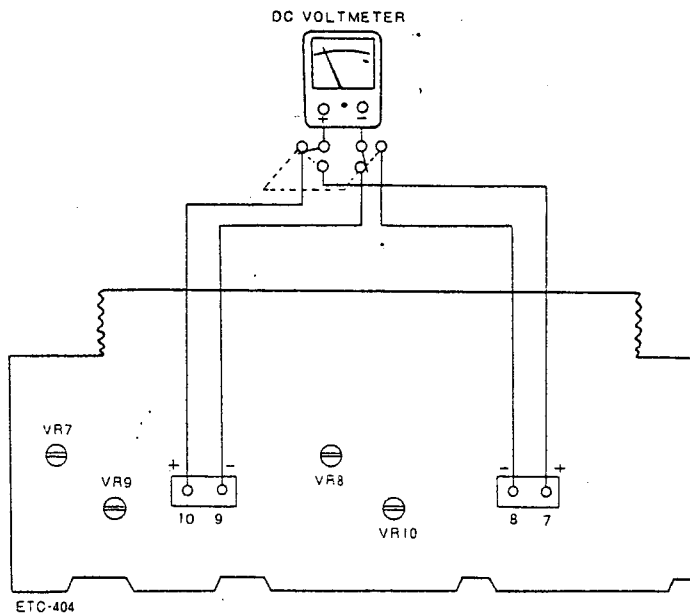

IDLE CURRENT ADJUSTMENT METHOD OF TONE & POWER AMP (ETC-404 PRINTED BOARD)

- Place the unit in normal position, not sideways or tilted. Avoid too much ventilation, since the adjustment must be done where temperature is between 15°C and 30°C.
- Set the switches on the unit as follows:

Power	→ OFF
Volume	→ $-\infty$ dB
Direct couple	→ DIRECT
Speaker terminals	→ No load (no speaker connected)
- Remove the top cover, and the VR7,8,9 and 10 of the tone & power amp printed board (2220609001) fully counter clockwise.
Connect a DC voltmeter to the test points 7(+), 8(-) or to 10(+), 9(-)
- Plug in the AC cord to power outlet of: Europe 220 V (198~231 V); U.K. and Australia 240 V (216~252 V); Canada and U.S.A. 120 V (180~126 V); and turn the power on.
Immediately (within one minute), turn VR7 and VR8 clockwise and adjust the test point voltage (V_{TP}) to 10 ± 1 mV preliminarily.
- After about two or three minutes of the above preliminary adjustment, adjust VR7 and VR8 so as V_{TP} reads 15 ± 1 mV.
- Adjust VR9 and VR10 so as V_{TP} reads 25 ± 2 mV preliminarily.
- About 4 minutes after the above preliminary adjustment, adjust VR9 and VR10 so as V_{TP} reads 33 ± 2 mV.

ADJUSTMENT OF EQUALIZER (AUE-012 PRINTED BOARD)

- Insert short pins into PHONO input terminals.
- Connect a digital voltmeter (0.01 mV ~ 1 mV DC range must be measurable) into each of REC. out terminals (L & R channels).
- For easier measuring to avoid value fluctuation on the meter, connect a 100 k ohm (1/4W) resistor between the ends of the R17/18 10 M ohms (1/4W) resistor on the printed board.
- Set the FUNCTION switch to "MM" position, and turn the main volume to MIN.

ADJUSTMENT

1. Turn POWER on, and after two minutes warming-up conduct the following adjustments.
2. Adjust VR1 (100 ohms semi-solid volume), so as the L-channel digital voltmeter reads 0.5 mV DC or less.
3. Adjust VR2 (100 ohms semi-solid volume), so as the R-channel digital voltmeter reads 0.5 mV DC or less.

NOTES ON SERVICING REMOTE SWITCH

A. How to remove control wire (TAPE MONITOR, REC OUT SELECTOR). (See Fig. 1)

- (1) Do not handle Adapter pins (2) forcedly.
- (2) Do not pull the wire to detach adapter.
- (3) Procedure to remove.
 - (a) Insert a small sized screwdriver for adjustment into the space between the adapter and the switch (Fig. 1), move the driver up and down slightly, and detach the adapter which is moved upward.
 - (b) If no small sized screwdriver is available, move the adapter upward and detach it.
- (4) Do not apply implement forcedly or the leg may break off.

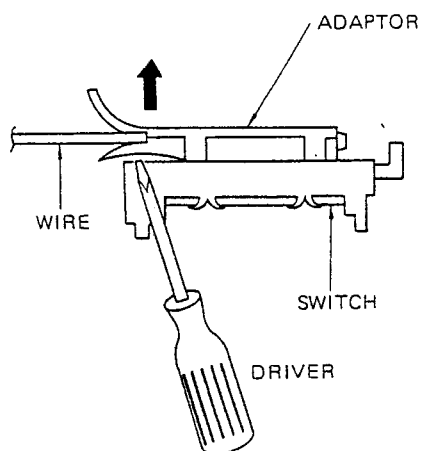
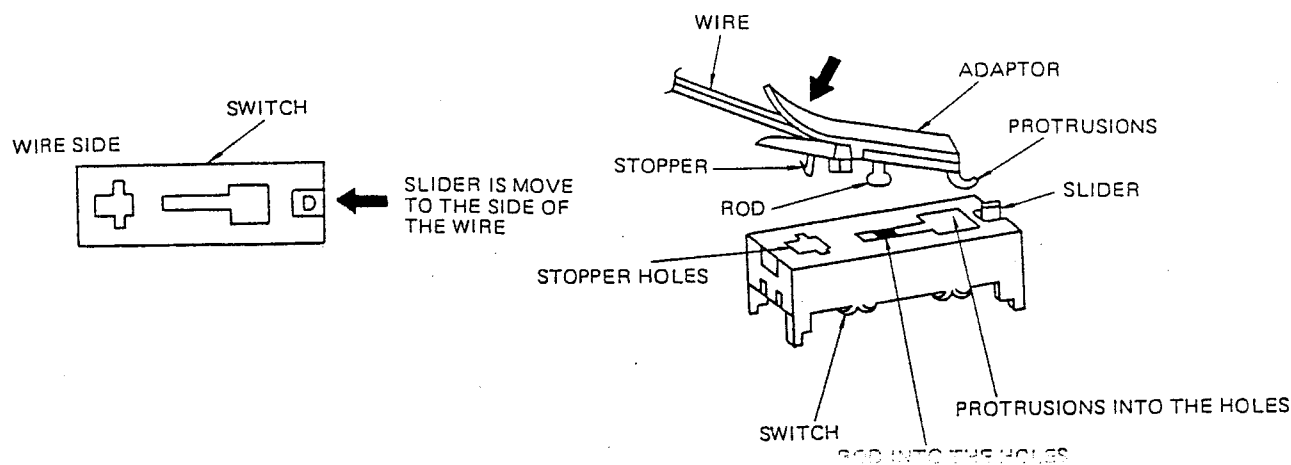



Fig. 1

B. HOW TO INSTALL CONTROL WIRE (See Fig. 2)

- (1) Turn rotary control shaft on front panel side fully counterclockwise.
- (2) Hold adapter on switch side, and move it to switch frame rear.
- (3) Slide the switch in the direction of the control wire with a thin implement.
- (4) Insert the adapter protrusions into the holes on the switch side. Then insert the adapter rods into the specified holes and simultaneously insert the stoppers into the stopper holes until they click.
- (5) Turn the control to check.



EXPLODED VIEW OF CHASSIS AND CABINET

⚠   Means important safety item, which must be rechecked when necessary, by a part specified or meeting the specification by the manufacturer.

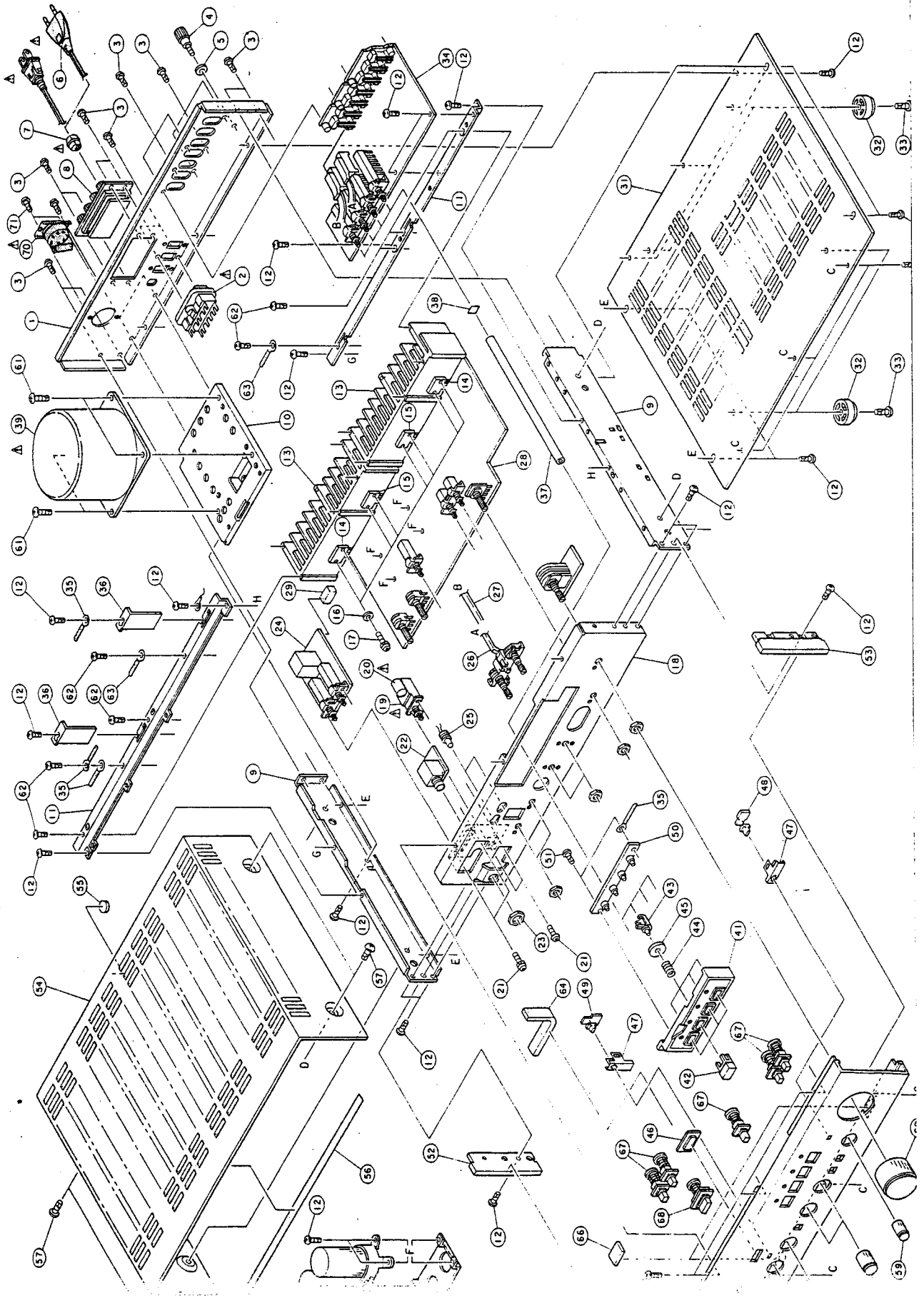

EXPLODED VIEW OF PARTS LIST

Note: 1. See addendum list below for the parts with asterisk (*) on the Ref. No. and the other parts not included in this list.
2. This list is prepared based on E1.

Ref. No.	Part No.	Part Name & Descriptions	Ref. No.	Part No.	Part Name & Descriptions
*1	1050369004	BACK PANEL	40	1440737204	FRONT PANEL ASS.
*2	2033909008	AC OUTLET	41	1140047317	PANEL BUSH (A)
3	4770064107	FIXING SCREW	42	1130171222	PUSH KNOB ASS.
4	2050071016	TERMINAL	43	1190021008	STOPPER
5	4770018001	WASHER	44	4630220007	SPRING
*6	2006031026	AC CORD	45	1250009209	WASHER
*7	MD-3802	BUSHING	46	1430180104	LENS
8	2050070004	8P. TERMINAL	47	4120789100	LED HOLD BRACKET
9	4110216706	SIDE CHASSIS	*48	AUE-012D6	EQ LED UNIT
10	4110246103	TRANS CHASSIS	*49	AUE-012D7	EQ LED UNIT
11	4120780206	RADIATOR BRACKET	*50	AUE-012D3	INPUT LED UNIT
12	4730354019	TAPPING SCREW (2) 3x8	51	4730304014	TAPPING SCREW (1) 3x8
13	470130000	POWER RADIATOR	52	1460338104	ESC. PLATE (L)
14	2730243025	TRANSISTOR 2SC2838(O)&(Y)	53	1460339103	ESC. PLATE (R)
15	2710143022	TRANSISTOR 2SA1187(O)&(Y)	54	1020107005	TOP COVER
16	-	-	55	1040034006	STOPPER
17	4700012022	CROSS PAN SCREW WITH S. WASHER 3x12	56	1220069008	SPACER
18	4120781108	FRONT CHASSIS ASS.	57	4734801005	TAPPING SCREW TRANS 4x8
*19	2124263022	PUSH SWITCH	58	1120321011	KNOB ASS. (A)
*20	2538003014	CERAMIC CAPACITOR 0.0047µF 400V	59	1120320009	KNOB ASS. (B)
21	4700009006	CROSS PAN SCREW WITH S. WASHER 3x6	60	1120265203	KNOB
*22	AUE-012D5	HEADPHONE JACK UNIT	*61	4730455015	TAPPING SCREW (2) 4x10
23	-	φ12 NUT	62	4700026005	TAPPING SCREW (1) WITH WASHER 3x8
*24	AUE-012D2	SPEAKER SWITCH UNIT	63	EP-4772	CORD HOLDER
25	3930059005	PILOT LAMP 28 V 40 mA	64	4610155008	BLIND
26	2120169007	ROTARY REMOTE (A) FOR T/M	65	4120785007	CONDENSER BRACKET
27	2120170009	ROTARY REMOTE (B) FOR REC OUT	66	1250004020	SPACER
*28	ETC-404D	EQ. AMP UNIT	67	1130196003	PUSH KNOB ASS.
29	4610154009	CUSHION	68	1130196016	PUSH KNOB ASS.
30	2432029013	WIRE WOUND RESISTOR 0.33 ohm/0.33 ohm 5 W	*69	AUE-012D8	5P. DIN UNIT
31	1050325103	BOTTOM COVER	△70	2120186006	VOLTAGE SELECTOR SWITCH
32	1048001002	FOOT	71	4711303034	CROSS PAN SCREW 3x6 BLACK
33	4730455015	TAPPING SCREW (2) 4x10	72	4751005004	φ4 WASHER
*34	AUE-012D	EQ. AMP UNIT	73	4610160006	WASHER
35	EP-6214	CORD HOLDER	74	SC-1161	TAPPING SCREW
36	4120784008	TRANSISTOR HOLDER BRACKET	75	4450033005	WIRE CLAMP BAND USED 11
37	4430241105	CONNECTING SHAFT	PACKING & ACCESSORIES		
38	1220064087	SPACER	(100)	5040052013	CABINET COVER
△39	2335280001	POWER TRANS	(101)	5030262004	CUSHION
			* (102)	5010702050	CARTON CASE
			(103)	5110857009	INST. MANUAL

ADDENDUM LIST

Ref. No.	Part Name	Part No.					
		EA For Australia	E2 For Europe	EF For France	EK For U.K.	E3 For U.S.A.	EC For Canada
1	BACK PANEL	1050372004	1050372004	1050372004	1050372004	1050373003	1050374002
△ 2	AC CORD	2062012005	2062002031	2062002031	2062020000	2033910000	2033910000
△ 6	CORD BUSH	MD-2982H	4450020005	4450020005	MD-2982H	MD-3802	MD-3802
△ 7	POWER SWITCH	2124263022	2124263022	2124263022	2124263022	2124263019	2124263019
△ 19	CAPACITOR	2538003014	2538003014	2538003014	2538003014	2568019007	2568019007
△ 20	HEADPHONE JACK UNIT	AUE-012B5	AUE-012B5	AUE-012B5	AUE-012B5	AUE-012C5	AUE-012C5
22	SPEAKER SWITCH UNIT	AUE-012B2	AUE-012B2	AUE-012B2	AUE-012B2	AUE-012C2	AUE-012C2
24	TONE & POWER UNIT	ETC-404B	ETC-404B	ETC-404B	ETC-404B	ETC-404C	ETC-404C
28	EQ. AMP UNIT	AUE-012B	AUE-012B	AUE-012B	AUE-012B	AUE-012C	AUE-012C
34	POWER TRANS	2335272006	2335271007	2335271007	2335272006	2335270008	2335270008
48	EQ. LED UNIT	AUE-012B6	AUE-012B6	AUE-012B6	AUE-012B6	AUE-012C6	AUE-012C6
49	TONE LED UNIT	AUE-012B7	AUE-012B7	AUE-012B7	AUE-012B7	AUE-012C7	AUE-012C7
50	INPUT LED UNIT	AUE-012B3	AUE-012B3	AUE-012B3	AUE-012B3	AUE-012C3	AUE-012C3
61	TAPPING SCREW (FOR POWER TRANS)	4700031016	470031016	4700031016	4700031016	4730455015	4730455015
69	5P. DIN UNIT	4x10(2)T.W.B.	4x10(2)T.W.B.	4x10(2)T.W.B.	4x10(2)T.W.B.	4x10(2)	4x10(2)
75	WIRE CLAMP BAND	AUE-012B8	AUE-012B8	AUE-012B8	AUE-012B8	AUE-012C8	AUE-012C8
76	3P. TERMINAL BLOCK	4450033005	4450033005	4450033005	4450033005	445033005	445033005
77	INSULATING SHEET (B)	USED 15	USED 11	USED 11	USED 12	USED 11	USED 11
78	TERMINAL PLATE	2050086014	-	-	-	-	-
79	TAPPING SCREW (2)	4150094001	-	-	-	-	-
80	φ3 TOOTH WASHER	4120856004	-	-	-	-	-
81	EARTH LABEL	4730359014	-	-	-	-	-
82	φ4 TOOTH WASHER	4753001051	-	-	4753001051	-	-
83	VOLTAGE LABEL	5130140000	-	-	5130140000	-	-
84	WIRE ASS.	4753100004	-	-	4753100004	-	-
85	BLIND SHEET	5130362008	-	-	5130362008	-	-
86	7P. W TERMINAL	2030176122	-	-	2030176151	-	-
87	INSULATING SHEET	5130348006	-	-	5130348006	-	-
88	CROSS PAN SCREW	-	2050089008	2050089008	-	-	-
89	φ3 NUT	-	4150088004	4150088004	4150088004	-	-
90	FUSE LABEL	-	4700042005	4700042005	4700042005	-	-
91	SERIAL NO. PLATE	-	4756006008	4756006008	4756006008	-	-
92	RIVET	-	-	-	-	-	-
93	CSA LABEL	-	-	-	-	-	-
(102)	CARTON CASE	-	-	-	-	5130270080	5130270080
(104)	NOTICE SHEET (FOR TOP COVER)	5010702050	5010702050	5010702050	5010702050	5130398166	-
(105)	NOTICE SHEET (FOR AC CORD)	5130209006	-	-	-	4770126016	-
		5130210008	-	-	-	-	5130200005

PRINTED CIRCUIT BOARD PATTERNS AND PARTS LIST

EQ. AMP. UNIT. AUE-012D for Hong Kong & Singapore, AUE-012B for Australia, Europe, France, U.K., AUE-012C for U.S.A. and Canada.

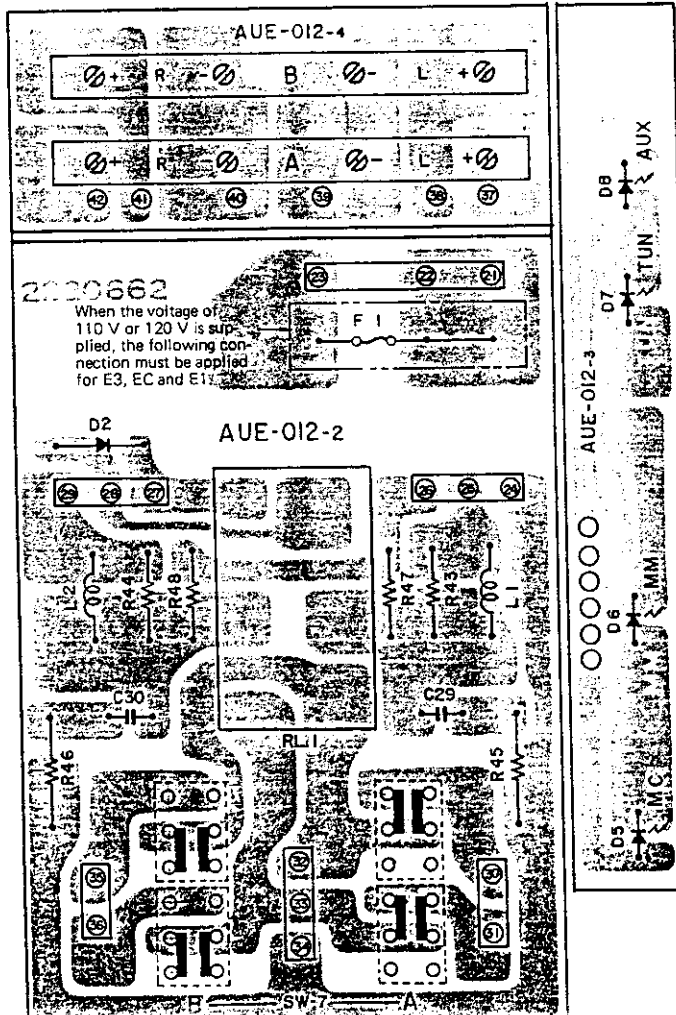
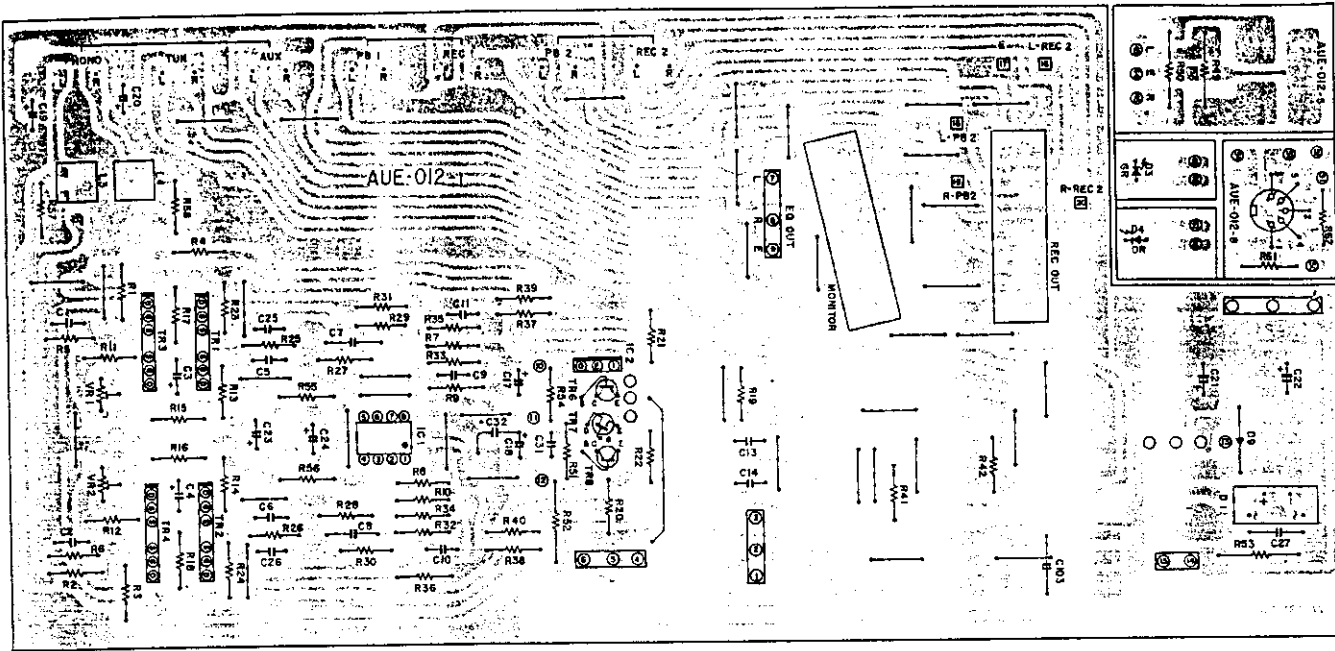

AUE-012D EQ. AMP UNIT PARTS LIST

Ref. No.	Part No.	Part Name & Descriptions	
SEMICONDUCTORS			
IC01	2650034000	NJM4559D-D	INTEGRATED CIRCUIT
IC02	2630155006	μ PC78M15	INTEGRATED CIRCUIT
TR01	2750024017	μ PA68H(L)	FIELD EFFECT TRANSISTOR
TR02	2750024017	μ PA68H(L)	FIELD EFFECT TRANSISTOR
TR03	2750024017	μ PA68H(L)	FIELD EFFECT TRANSISTOR
TR04	2750024017	μ PA68H(L)	FIELD EFFECT TRANSISTOR
TR06	2710102005	2SA1015(Y)	TRANSISTOR
TR07	2750018007	2SK30A(R)	FIELD EFFECT TRANSISTOR
TR08	2710117003	2SA1020(Y)	TRANSISTOR
D01	27600246018	RB-152	DIODE
D02	2760049011	1S2076A	DIODE
D03	3939038014	LED (GREEN)	LIGHT EMITTING DIODE
D04	3939046006	LED (ORANGE)	LIGHT EMITTING DIODE
D05	3939040002	TLG206(GREEN)	LIGHT EMITTING DIODE
D06	3939040002	TLG206(GREEN)	LIGHT EMITTING DIODE
D07	3939040002	TLG206(GREEN)	LIGHT EMITTING DIODE
D08	3939040002	TLG206(GREEN)	LIGHT EMITTING DIODE
D09	2760158009	W06A	DIODE
RESISTORS			
R01	2410266005	10 ohm \pm 5% $\frac{1}{4}$ W	FIXED CARBON FILM
R02	2410266005	10 ohm \pm 5% $\frac{1}{4}$ W	FIXED CARBON FILM
R03	2410290000	100 ohm \pm 5% $\frac{1}{4}$ W	FIXED CARBON FILM
R04	2410290000	100 ohm \pm 5% $\frac{1}{4}$ W	FIXED CARBON FILM
R05	2410355000	51 k ohm \pm 5% $\frac{1}{4}$ W	FIXED CARBON FILM
R06	2410355000	51 k ohm \pm 5% $\frac{1}{4}$ W	FIXED CARBON FILM
R07	2410320006	1.8 k ohm \pm 5% $\frac{1}{4}$ W	FIXED CARBON FILM
R08	2410320006	1.8 k ohm \pm 5% $\frac{1}{4}$ W	FIXED CARBON FILM
R09	2410320006	1.8 k ohm \pm 5% $\frac{1}{4}$ W	FIXED CARBON FILM
R10	2410320006	1.8 k ohm \pm 5% $\frac{1}{4}$ W	FIXED CARBON FILM
R11	2410266005	10 ohm \pm 5% $\frac{1}{4}$ W	FIXED CARBON FILM
R12	2410266005	10 ohm \pm 5% $\frac{1}{4}$ W	FIXED CARBON FILM
R13	2410318005	1.5 k ohm \pm 5% $\frac{1}{4}$ W	FIXED CARBON FILM
R14	2410318005	1.5 k ohm \pm 5% $\frac{1}{4}$ W	FIXED CARBON FILM
R15	2410318005	1.5 k ohm \pm 5% $\frac{1}{4}$ W	FIXED CARBON FILM
R16	2410318005	1.5 k ohm \pm 5% $\frac{1}{4}$ W	FIXED CARBON FILM
R17	2420203003	10 M ohm \pm 10% $\frac{1}{4}$ W	FIXED CARBON COMPOSIT
R18	2420203003	10 M ohm \pm 10% $\frac{1}{4}$ W	FIXED CARBON COMPOSIT
R19	2410760006	620 k ohm \pm 5% $\frac{1}{4}$ W	FIXED CARBON FILM
R20	2410760006	620 k ohm \pm 5% $\frac{1}{4}$ W	FIXED CARBON FILM
R21	2410267004	11 ohm \pm 5% $\frac{1}{4}$ W	FIXED CARBON FILM
R22	2410267004	11 ohm \pm 5% $\frac{1}{4}$ W	FIXED CARBON FILM
R23	2410290000	100 ohm \pm 5% $\frac{1}{4}$ W	FIXED CARBON FILM
R24	2410290000	100 ohm \pm 5% $\frac{1}{4}$ W	FIXED CARBON FILM
R25	2412032046	4.7 k ohm \pm 2% $\frac{1}{4}$ W	FIXED CARBON FILM
R26	2412032046	4.7 k ohm \pm 2% $\frac{1}{4}$ W	FIXED CARBON FILM
R27	2412018044	56 k ohm \pm 2% $\frac{1}{4}$ W	FIXED CARBON FILM
R28	2412018044	56 k ohm \pm 2% $\frac{1}{4}$ W	FIXED CARBON FILM
R29	2410302008	330 ohm \pm 5% $\frac{1}{4}$ W	FIXED CARBON FILM
R30	2410302008	330 ohm \pm 5% $\frac{1}{4}$ W	FIXED CARBON FILM
R31	2410273001	20 ohm \pm 5% $\frac{1}{4}$ W	FIXED CARBON FILM
R32	2410273001	20 ohm \pm 5% $\frac{1}{4}$ W	FIXED CARBON FILM
R33	2410306004	470 ohm \pm 5% $\frac{1}{4}$ W	FIXED CARBON FILM
R34	2410306004	470 ohm \pm 5% $\frac{1}{4}$ W	FIXED CARBON FILM
R35	2410297003	200 ohm \pm 5% $\frac{1}{4}$ W	FIXED CARBON FILM
R36	2410297003	200 ohm \pm 5% $\frac{1}{4}$ W	FIXED CARBON FILM
R37	2410299001	240 ohm \pm 5% $\frac{1}{4}$ W	FIXED CARBON FILM
R38	2410299001	240 ohm \pm 5% $\frac{1}{4}$ W	FIXED CARBON FILM
R39	2410362006	100 k ohm \pm 5% $\frac{1}{4}$ W	FIXED CARBON FILM
R40	2410362006	100 k ohm \pm 5% $\frac{1}{4}$ W	FIXED CARBON FILM
R41	2410290000	100 ohm \pm 5% $\frac{1}{4}$ W	FIXED CARBON FILM
R42	2410290000	100 ohm \pm 5% $\frac{1}{4}$ W	FIXED CARBON FILM
R43	2410282005	47 ohm \pm 5% $\frac{1}{4}$ W	FIXED CARBON FILM
R44	2410282005	47 ohm \pm 5% $\frac{1}{4}$ W	FIXED CARBON FILM
R45	2440017020	10 ohm \pm 5% 1W	FIXED METAL OXIDE FILM
R46	2440017020	10 ohm \pm 5% 1W	FIXED METAL OXIDE FILM
R47	2410351004	36 k ohm \pm 5% $\frac{1}{4}$ W	FIXED CARBON FILM
R48	2410351004	36 k ohm \pm 5% $\frac{1}{4}$ W	FIXED CARBON FILM
R49	2440033020	220 ohm \pm 5% 1W	FIXED METAL OXIDE FILM
R50	2440033020	220 ohm \pm 5% 1W	FIXED METAL OXIDE FILM
R51	2410342000	15 k ohm \pm 5% $\frac{1}{4}$ W	FIXED CARBON FILM
R52	2410183007	820 ohm \pm 5% $\frac{1}{4}$ W	FIXED CARBON FILM
R53	2440089029	180 ohm \pm 5% 2W	FIXED METAL OXIDE FILM

Ref. No.	Part No.	Part Name & Descriptions	
R56	2410307003	510 ohm \pm 5% $\frac{1}{4}$ W	FIXED CARBON FILM
R57	2410298002	220 ohm \pm 5% $\frac{1}{4}$ W	FIXED CARBON FILM
R58	2410298002	220 ohm \pm 5% $\frac{1}{4}$ W	FIXED CARBON FILM
R61	2410378003	470 k ohm \pm 5% $\frac{1}{4}$ W	FIXED CARBON FILM
R62	2410378003	470 k ohm \pm 5% $\frac{1}{4}$ W	FIXED CARBON FILM
CAPACITORS			
C01	2533629008	120pF \pm 5%	50V FIXED CERAMIC
C02	2533629008	120pF \pm 5%	50V FIXED CERAMIC
C03	2541002002	6.8 μ F \pm 20%	6.3V FIXED TANTALUM
C04	2541002002	6.8 μ F \pm 20%	6.3V FIXED TANTALUM
C05	2554173009	0.015 μ F \pm 5%	50V FIXED PLASTIC FILM
C06	2554173009	0.015 μ F \pm 5%	50V FIXED PLASTIC FILM
C07	2554187008	0.056 μ F \pm 5%	50V FIXED PLASTIC FILM
C08	2554187008	0.056 μ F \pm 5%	50V FIXED PLASTIC FILM
C09	2554137003	470pF \pm 5%	50V FIXED PLASTIC FILM
C10	2554137003	470pF \pm 5%	50V FIXED PLASTIC FILM
C11	2551120026	0.0015 μ F \pm 5%	50V FIXED PLASTIC FILM
C12	2551120026	0.0015 μ F \pm 5%	50V FIXED PLASTIC FILM
C13	2551120055	0.0027 μ F \pm 5%	50V FIXED PLASTIC FILM
C14	2551120055	0.0027 μ F \pm 5%	50V FIXED PLASTIC FILM
C17	2544017007	47 μ F	16V FIXED ELECTROLYTIC
C18	2544017007	47 μ F	16V FIXED ELECTROLYTIC
C19	2544043000	0.47 μ F	50V FIXED ELECTROLYTIC
C20	2544043000	0.47 μ F	50V FIXED ELECTROLYTIC
C21	2544032008	1000 μ F	25V FIXED ELECTROLYTIC
C22	2544031009	470 μ F \pm 5%	25V FIXED ELECTROLYTIC
C23	2544011003	220 μ F	10V FIXED ELECTROLYTIC
C24	2544011003	220 μ F	10V FIXED ELECTROLYTIC
C25	2554143000	820pF \pm 5%	50V FIXED PLASTIC FILM
C26	2554143000	820pF \pm 5%	50V FIXED PLASTIC FILM
C27	2531053003	0.01 μ F +100,-0%	100V FIXED CERAMIC
C29	2551076002	0.022 μ F +100,-0%	50V FIXED PLASTIC FILM
C30	2551076002	0.022 μ F +100,-0%	50V FIXED PLASTIC FILM
C31	2533611003	22pF \pm 5%	50V FIXED CERAMIC
C32	2531024003	0.01 μ F +80,-20%	50V FIXED CERAMIC
C103	2544018006	100 μ F	16V FIXED ELECTROLYTIC
OTHER PARTS			
	2220662103	P.W. BOARD	
	2090042908	JUMPER SHORTLEAD USED 39	
	2090008117	JUMPER SHORTLEAD P=12.5 mm USED 3	
	EP-5870	FUSE HOLDER USED 2	
*F01	2061017027	FUSE HOLDER USED 2	
SW01	2124219005	4P. PUSH SWITCH FOR INPUT SEL.	
SW02	2124222005	SLIDE SWITCH (4 CIRCUIT 4 POSITION) FOR T/M	
SW03	2124222005	SLIDE SWITCH (4 CIRCUIT 4 POSITION) FOR REC OUT	
SW07	2124262007	2P. PUSH SWITCH FOR SPEAKER	
L01	2320017001	INDUCTOR 1 μ H	
L02	2320017001	INDUCTOR 1 μ H	
L03	2318017000	INDUCTOR 1 μ H	
L04	2318017000	INDUCTOR 1 μ H	
RL01	2140037009	RELAY DC48V 2-CIRCUIT	
VR01	2116014001	SEMI FIXED RESISTOR 100 OHM	
VR02	2116014001	SEMI FIXED RESISTOR 100 OHM	
	4140116106	SHIELD COVER	
	2048047007	HEADPHONE JACK	
	2036084001	4P. CONNECTOR BASE FOR INPUT "TAPE"	
	2040079002	6P. CONNECTOR BASE FOR INPUT "PHONO"	
	2050087026	2P. TERMINAL P=7.5 mm USED 2	
	2050087039	3P. TERMINAL P=7.5 mm USED 2	
	2050087042	4P. TERMINAL P=7.5 mm USED 1	
	2050082021	2P. TERMINAL P=5 mm USED 1	
	2050082034	3P. TERMINAL P=5 mm USED 1	
	2048070003	5P. CONNECTOR (DIN)	

AUE-012B PARTS LIST (for EA,E2,EF,EK)

Ref. No.	Part No.	Part Name & Descriptions
F01	2020014003	FUSE CLIP
	2061615087	FUSE (4A TIME LAG TYPE)
	5130159185	FUSE LABEL

AUE-012C PARTS LIST (for E3 and EC)

Ref. No.	Part No.	Part Name & Descriptions
	EP-5667H1	TERMINAL FOR WRAPPING PIN USED 5

TONE & POWER UNIT

ETC-404B for Hong Kong & Singapore, Australia, Europe, France, U.K., ETC-404C for U.S.A. Canada.

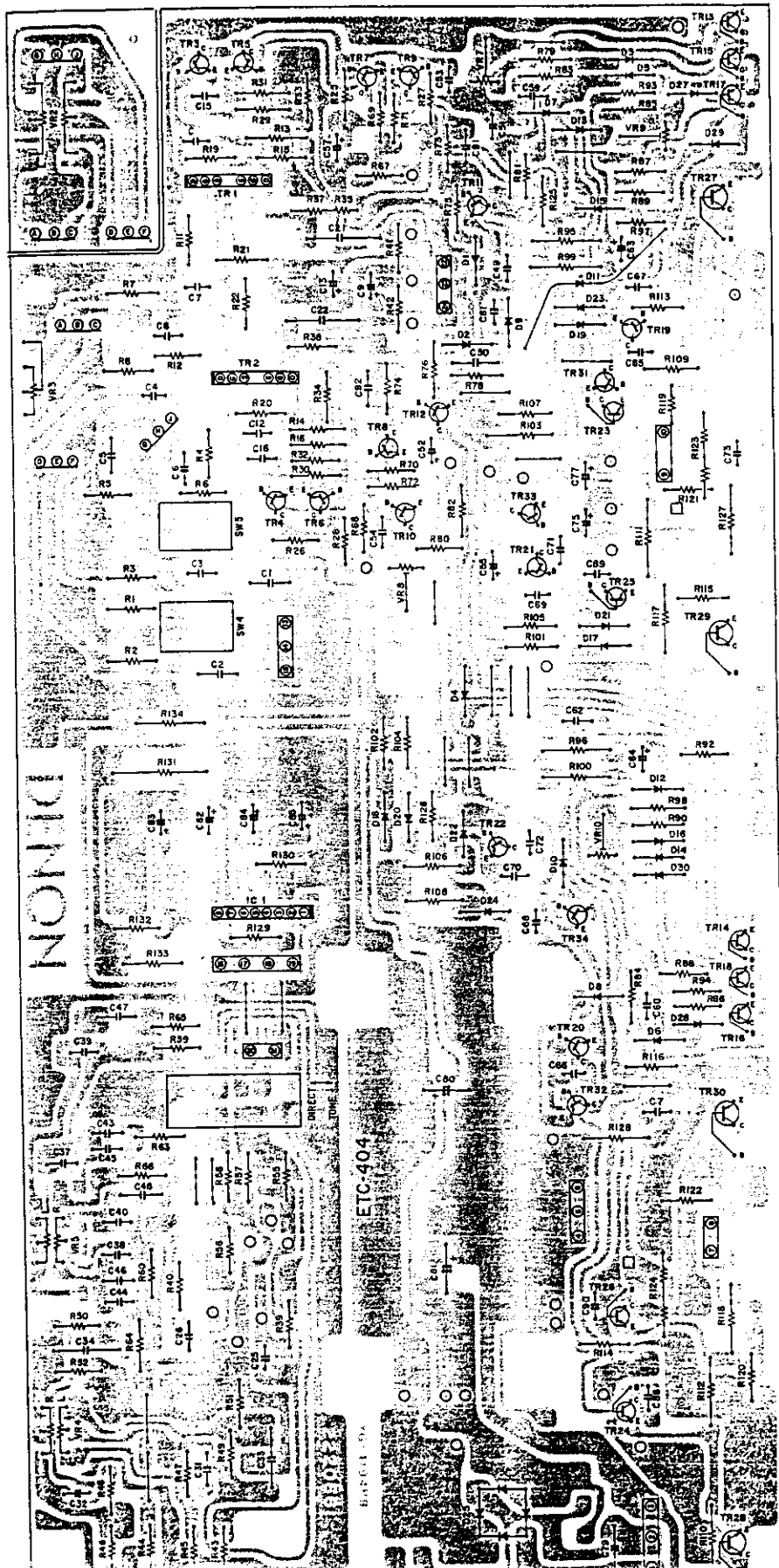

ETC-404B TONE & POWER UNIT PARTS LIST

Ref. No.	Part No.	Part Name & Descriptions	Ref. No.	Part No.	Part Name & Descriptions
SEMICONDUCTORS					
IC01	2630102004	HA12002W INTEGRATED CIRCUIT	△R26	2412314010	390 ohm ±5% ¼W FIXED CARBON FILM
TR01	2750024033	μPA68H(L)/(M) FIELD EFFECT TRANSISTOR	△R27	2412314010	390 ohm ±5% ¼W FIXED CARBON FILM
TR02	2750024033	μPA68H(L)/(M) FIELD EFFECT TRANSISTOR	△R28	2412314010	390 ohm ±5% ¼W FIXED CARBON FILM
TR03	2730235020	2SC1841(F)/(E) TRANSISTOR	R29	2410266005	10 ohm ±5% ¼W FIXED CARBON FILM
TR04	2730235020	2SC1841(F)/(E) TRANSISTOR	R30	2410266005	10 ohm ±5% ¼W FIXED CARBON FILM
TR05	2730235020	2SC1841(F)/(E) TRANSISTOR	R31	2410266005	10 ohm ±5% ¼W FIXED CARBON FILM
TR06	2730235020	2SC1841(F)/(E) TRANSISTOR	R32	2410266005	10 ohm ±5% ¼W FIXED CARBON FILM
TR07	2710131021	2SA988(F)/(E) TRANSISTOR	△R33	2412314036	750 ohm ±5% ¼W FIXED CARBON FILM
TR08	2710131021	2SA988(F)/(E) TRANSISTOR	△R34	2412314036	750 ohm ±5% ¼W FIXED CARBON FILM
TR09	2710131021	2SA988(F)/(E) TRANSISTOR	R35	2420203003	10 M ohm ±10% ¼W FIXED CARBON COMPOSIT
TR10	2710131021	2SA988(F)/(E) TRANSISTOR	R36	2420203003	10 M ohm ±10% ¼W FIXED CARBON COMPOSIT
TR11	2730235020	2SC1841(F)/(E) TRANSISTOR	R37	2420203003	10 M ohm ±10% ¼W FIXED CARBON COMPOSIT
TR12	2730235020	2SC1841(F)/(E) TRANSISTOR	R38	2420203003	10 M ohm ±10% ¼W FIXED CARBON COMPOSIT
TR13	2730198015	2SC1815(BL) TRANSISTOR	R39	2410336006	6.2 k ohm ±5% ¼W FIXED CARBON FILM
TR14	2730198057	2SC1815(Y)/(O) TRANSISTOR	R40	2410336006	6.2 k ohm ±5% ¼W FIXED CARBON FILM
TR15	2730171016	2SC1313(G) TRANSISTOR	R41	2410301009	300 ohm ±5% ¼W FIXED CARBON FILM
TR16	2730171016	2SC1313(G) TRANSISTOR	R42	2410301009	300 ohm ±5% ¼W FIXED CARBON FILM
TR17	2710087010	2SA726(G) TRANSISTOR	R43	2410306004	470 ohm ±5% ¼W FIXED CARBON FILM
TR18	2710087010	2SA726(G) TRANSISTOR	R44	2410306004	470 ohm ±5% ¼W FIXED CARBON FILM
TR19	2730198002	2SC1815(Y) TRANSISTOR	R45	2410336003	8.2 k ohm ±5% ¼W FIXED CARBON FILM
TR20	2730198002	2SC1815(Y) TRANSISTOR	R46	2410336003	8.2 k ohm ±5% ¼W FIXED CARBON FILM
TR21	2710102005	2SA1015(Y) TRANSISTOR	R47	2410360008	82 k ohm ±5% ¼W FIXED CARBON FILM
TR22	2710102005	2SA1015(Y) TRANSISTOR	R48	2410360008	82 k ohm ±5% ¼W FIXED CARBON FILM
TR23	2730226026	2SC2275(Q)/(R) TRANSISTOR	R49	2410337002	9.1 k ohm ±5% ¼W FIXED CARBON FILM
TR24	2730226026	2SC2275(Q)/(R) TRANSISTOR	R50	2410337002	9.1 k ohm ±5% ¼W FIXED CARBON FILM
TR25	2710123026	2SA985(Q)/(R) TRANSISTOR	R51	2410316007	1.2 k ohm ±5% ¼W FIXED CARBON FILM
TR26	2710123026	2SA985(Q)/(R) TRANSISTOR	R52	2410316007	1.2 k ohm ±5% ¼W FIXED CARBON FILM
△R31	2710102005	2SA1015(Y) TRANSISTOR	R55	2410352003	39 k ohm ±5% ¼W FIXED CARBON FILM
△R32	2710102005	2SA1015(Y) TRANSISTOR	R56	2410352003	39 k ohm ±5% ¼W FIXED CARBON FILM
TR33	2730198002	2SC1815(Y) TRANSISTOR	R57	2410356009	56 k ohm ±5% ¼W FIXED CARBON FILM
TR34	2730198002	2SC1815(Y) TRANSISTOR	R58	2410356009	56 k ohm ±5% ¼W FIXED CARBON FILM
D01	2760171028	HV-23G(YL) DIODE	R59	2410285002	62 ohm ±5% ¼W FIXED CARBON FILM
D02	2760171028	HV-23G(YL) DIODE	R60	2410285002	62 ohm ±5% ¼W FIXED CARBON FILM
D03	2760049008	1S2076 DIODE	R63	2410321005	2 k ohm ±5% ¼W FIXED CARBON FILM
D04	2760049008	1S2076 DIODE	R64	2410321005	2 k ohm ±5% ¼W FIXED CARBON FILM
D05	2760049008	1S2076 DIODE	R65	2410301009	300 ohm ±5% ¼W FIXED CARBON FILM
D06	2760049008	1S2076 DIODE	R66	2410301009	300 ohm ±5% ¼W FIXED CARBON FILM
D07	2760049008	1S2076 DIODE	△R67	2412313008	100 ohm ±2% ¼W FIXED CARBON FILM
D08	2760049008	1S2076 DIODE	△R68	2412313008	100 ohm ±2% ¼W FIXED CARBON FILM
D09	2760049008	1S2076 DIODE	R69	2410266005	10 ohm ±5% ¼W FIXED CARBON FILM
D10	2760049008	1S2076 DIODE	R70	2410266005	10 ohm ±5% ¼W FIXED CARBON FILM
D11	2760049008	1S2076 DIODE	R71	2410266005	10 ohm ±5% ¼W FIXED CARBON FILM
D12	2760049008	1S2076 DIODE	R72	2410266005	10 ohm ±5% ¼W FIXED CARBON FILM
D13	2760254000	HZ7B-3 DIODE	R73	2410211005	12 k ohm ±5% ¼W FIXED CARBON FILM
D14	2760254000	HZ7B-3 DIODE	R74	2410211005	12 k ohm ±5% ¼W FIXED CARBON FILM
D15	2760254000	HZ7B-3 DIODE	△R75	2412313037	220 ohm ±2% ¼W FIXED CARBON FILM
D16	2760254000	HZ7B-3 DIODE	△R76	2412313037	220 ohm ±2% ¼W FIXED CARBON FILM
*D17	2760221004	HZ-36 DIODE	△R77	2412313037	220 ohm ±2% ¼W FIXED CARBON FILM
*D18	2760221004	HZ-36 DIODE	△R78	2412313037	220 ohm ±2% ¼W FIXED CARBON FILM
*D19	2760221004	HZ-36 DIODE	R79	2410306004	470 ohm ±5% ¼W FIXED CARBON FILM
*D20	2760221004	HZ-36 DIODE	R80	2410306004	470 ohm ±5% ¼W FIXED CARBON FILM
D21	2760049011	1S2076A DIODE	R81	2410314009	1 k ohm ±5% ¼W FIXED CARBON FILM
D22	2760049011	1S2076A DIODE	R82	2410314009	1 k ohm ±5% ¼W FIXED CARBON FILM
D23	2760049011	1S2076A DIODE	△R83	2412313053	1 k ohm ±5% ¼W FIXED CARBON FILM
D24	2760049011	1S2076A DIODE	△R84	2412313053	1 k ohm ±5% ¼W FIXED CARBON FILM
△D25	2760233005	M4C-51 DIODE	R85	2410330009	4.7 k ohm ±5% ¼W FIXED CARBON FILM
△D26	2760049008	1S2076 DIODE	R86	2410330009	4.7 k ohm ±5% ¼W FIXED CARBON FILM
△D27	2760049008	1S2076 DIODE	R87	2410338001	10 k ohm ±5% ¼W FIXED CARBON FILM
D29	2760049008	1S2076 DIODE	R88	2410338001	10 k ohm ±5% ¼W FIXED CARBON FILM
D30	2760049008	1S2076 DIODE	R89	2410330009	4.7 k ohm ±5% ¼W FIXED CARBON FILM
RESISTORS			R90	2410330009	4.7 k ohm ±5% ¼W FIXED CARBON FILM
R01	2410290000	100 ohm ±5% ¼W FIXED CARBON FILM	△R91	2412313053	1 k ohm ±2% ¼W FIXED CARBON FILM
R02	2410290000	100 ohm ±5% ¼W FIXED CARBON FILM	△R92	2412313053	1 k ohm ±2% ¼W FIXED CARBON FILM
R03	2410349003	30 k ohm ±5% ¼W FIXED CARBON FILM	R93	2410314009	1 k ohm ±5% ¼W FIXED CARBON FILM
R04	2410349003	30 k ohm ±5% ¼W FIXED CARBON FILM	R94	2410314009	1 k ohm ±5% ¼W FIXED CARBON FILM
R05	2410333006	6.2 k ohm ±5% ¼W FIXED CARBON FILM	△*R95	2440049027	4.7 k ohm ±5% 1W FIXED METAL OXIDE FILM
R06	2410333006	6.2 k ohm ±5% ¼W FIXED CARBON FILM	△*R96	2440049027	4.7 k ohm ±5% 1W FIXED METAL OXIDE FILM
△R07	2412314023	470 ohm ±5% ¼W FIXED CARBON FILM	R97	2410314009	1 k ohm ±5% ¼W FIXED CARBON FILM
△R08	2412314023	470 ohm ±5% ¼W FIXED CARBON FILM	R98	2410314009	1 k ohm ±5% ¼W FIXED CARBON FILM
△R11	2412314007	100 ohm ±5% ¼W FIXED CARBON FILM	△*R99	2440049027	4.7 k ohm ±5% 1W FIXED METAL OXIDE FILM
△R12	2412314007	100 ohm ±5% ¼W FIXED CARBON FILM	△*R100	2440049027	4.7 k ohm ±5% 1W FIXED METAL OXIDE FILM
R13	2412035014	8.2 k ohm ±2% ¼W FIXED CARBON FILM	R101	2410219007	27 k ohm ±5% ¼W FIXED CARBON FILM
R14	2412035014	8.2 k ohm ±2% ¼W FIXED CARBON FILM	R102	2410219007	27 k ohm ±5% ¼W FIXED CARBON FILM
R15	2412035014	8.2 k ohm ±2% ¼W FIXED CARBON FILM	R103	2410219007	27 k ohm ±5% ¼W FIXED CARBON FILM
R16	2412035014	8.2 k ohm ±2% ¼W FIXED CARBON FILM	R104	2410219007	27 k ohm ±5% ¼W FIXED CARBON FILM
R19	2410280007	39 ohm ±5% ¼W FIXED CARBON FILM			
R20	2410280007	39 ohm ±5% ¼W FIXED CARBON FILM			
R21	2410335004	7.5 k ohm ±5% ¼W FIXED CARBON FILM			
R22	2410335004	7.5 k ohm ±5% ¼W FIXED CARBON FILM			
△R25	2412314010	390 ohm ±5% ¼W FIXED CARBON FILM			

(Con.)

Ref. No.	Part No.	Part Name & Descriptions	Ref. No.	Part No.	Part Name & Descriptions
△R105	2440041025	1 k ohm ±5% 1W FIXED METAL OXIDE FILM	C43	2551120084	0.0047μF ±5% 50V FIXED PLASTIC FILM
△R106	2440041025	1 k ohm ±5% 1W FIXED METAL OXIDE FILM	C44	2551120084	0.0047μF ±5% 50V FIXED PLASTIC FILM
△R107	2440041025	1 k ohm ±5% 1W FIXED METAL OXIDE FILM	C45	2551120055	0.0027μF ±5% 50V FIXED PLASTIC FILM
△R108	2440041025	1 k ohm ±5% 1W FIXED METAL OXIDE FILM	C46	2551122011	0.0027μF ±5% 50V FIXED PLASTIC FILM
△R109	2440013024	4.7 ohm ±5% 1W FIXED METAL OXIDE FILM	C47	2551122011	0.056μF ±5% 50V FIXED PLASTIC FILM
△R110	2440013024	4.7 ohm ±5% 1W FIXED METAL OXIDE FILM	C48	2551122011	0.056μF ±5% 50V FIXED PLASTIC FILM
△R111	2440037026	470 ohm ±5% 1W FIXED METAL OXIDE FILM	C49	2533627000	100pF ±5% 50V FIXED CERAMIC
△R112	2440037026	470 ohm ±5% 1W FIXED METAL OXIDE FILM	C50	2533627000	100pF ±5% 50V FIXED CERAMIC
△R113	2412313024	150 ohm ±2% ¼W FIXED CARBON FILM	C51	2544060025	1μF 100V FIXED ELECTROLYTIC
△R114	2412313024	150 ohm ±2% ¼W FIXED CARBON FILM	C52	2544060025	1μF 100V FIXED ELECTROLYTIC
△R115	2412313024	150 ohm ±2% ¼W FIXED CARBON FILM	C53	2534269001	10pF ±0.5pF 500V FIXED CERAMIC
△R116	2412313024	150 ohm ±2% ¼W FIXED CARBON FILM	C54	2534269001	10pF ±0.5pF 500V FIXED CERAMIC
△R117	2440013024	4.7 ohm ±5% 1W FIXED METAL OXIDE FILM	C55	2544060025	1μF 100V FIXED ELECTROLYTIC
△R118	2440013024	4.7 ohm ±5% 1W FIXED METAL OXIDE FILM	C57	2544060025	1μF 100V FIXED ELECTROLYTIC
R119	2410282005	47 ohm ±5% ¼W FIXED CARBON FILM	C59	2533639001	330pF ±5% 50V FIXED CERAMIC
R120	2410282005	47 ohm ±5% ¼W FIXED CARBON FILM	C60	2533639001	330pF ±5% 50V FIXED CERAMIC
R121	2410282005	47 ohm ±5% ¼W FIXED CARBON FILM	C61	2533639001	330pF ±5% 50V FIXED CERAMIC
R122	2410282005	47 ohm ±5% ¼W FIXED CARBON FILM	C62	2533639001	330pF ±5% 50V FIXED CERAMIC
R123	2432029013	0.33 ohm 5W FIXED WIRE WOUND	C63	2544044009	1μF 50V FIXED ELECTROLYTIC
R124	2432029013	0.33 ohm 5W FIXED WIRE WOUND	C64	2544044009	1μF ±5% 50V FIXED ELECTROLYTIC
△R125	2412313066	47 ohm ±2% ¼W FIXED CARBON FILM	C65	2531008003	0.0047μF ±10% 50V FIXED CERAMIC
△R126	2412313066	47 ohm ±2% ¼W FIXED CARBON FILM	C66	2531008003	0.0047μF ±10% 50V FIXED CERAMIC
△R127	2440022028	27 ohm ±5% 1W FIXED METAL OXIDE FILM	C67	2531008003	0.0047μF ±10% 50V FIXED CERAMIC
△R128	2440022028	27 ohm ±5% 1W FIXED METAL OXIDE FILM	C68	2531008003	0.0047μF ±10% 50V FIXED CERAMIC
R129	2410330009	4.7 k ohm ±5% ¼W FIXED CARBON FILM	C69	2531008003	0.0047μF ±10% 50V FIXED CERAMIC
R130	2410338001	10 k ohm ±5% ¼W FIXED CARBON FILM	C70	2531008003	0.0047μF ±10% 50V FIXED CERAMIC
△R131	2440103028	2.7 k ohm ±5% 2W FIXED METAL OXIDE FILM	C71	2531008003	0.0047μF ±10% 50V FIXED CERAMIC
R132	2410769007	1.5 M ohm ±5% ¼W FIXED CARBON FILM	C72	2531008003	0.0047μF ±10% 50V FIXED CERAMIC
△R133	2440036027	390 ohm ±5% 1W FIXED METAL OXIDE FILM	C73	2551121025	0.01μF ±5% 50V FIXED PLASTIC FILM
R134	2410181009	680 ohm ±5% ¼W FIXED CARBON FILM	C74	2551121025	0.01μF ±5% 50V FIXED PLASTIC FILM
CAPACITORS			C75	2544060025	1μF 100V FIXED ELECTROLYTIC
C01	2551084007	0.1μF ±10% 50V FIXED PLASTIC FILM	C77	2544060025	1μF 100V FIXED ELECTROLYTIC
C02	2551084007	0.1μF ±10% 50V FIXED PLASTIC FILM	C79	2531053003	0.01μF +100,-0% 100V FIXED CERAMIC
C03	2533641002	390pF ±5% 50V FIXED CERAMIC	*C80	2546053108	15000μF/15000μV 63V FIXED ELECTROLYTIC
C04	2533641002	390pF ±5% 50V FIXED CERAMIC	*C81	2546053108	15000μF/15000μV 63V FIXED ELECTROLYTIC
C05	2551122037	0.082μF ±5% 50V FIXED PLASTIC FILM	C82	2544035005	10μF 35V FIXED ELECTROLYTIC
C06	2551122037	0.082μF ±5% 50V FIXED PLASTIC FILM	C83	2549015017	47μF ±10% 10V FIXED ELECTROLYTIC
C07	2533627000	100pF ±5% 50V FIXED CERAMIC	C84	2544066003	2.2μF 50V FIXED ELECTROLYTIC
C08	2533627000	100pF ±5% 50V FIXED CERAMIC	C85	2544004007	220μF 6.3V FIXED ELECTROLYTIC
C09	2544044009	1μF 50V FIXED ELECTROLYTIC	C87	2534321004	47pF ±10% 500V FIXED CERAMIC
C11	2531004007	0.001μF ±10% 50V FIXED CERAMIC	C88	2534321004	47pF ±10% 500V FIXED CERAMIC
C12	2531004007	0.001μF ±10% 50V FIXED CERAMIC	C89	2534321004	47pF ±10% 500V FIXED CERAMIC
C13	2544044009	1μF ±10% 50V FIXED ELECTROLYTIC	C90	2534321004	47pF ±10% 500V FIXED CERAMIC
C15	2533619005	47pF ±5% 50V FIXED CERAMIC	C91	2554079048	0.01μF ±5% 100V FIXED PLASTIC FILM
C16	2533619005	47pF ±5% 50V FIXED CERAMIC	C92	2554079048	0.01μF ±5% 100V FIXED PLASTIC FILM
C21	2561008060	1μF ±10% 100V FIXED METALIZED	OTHER PARTS		
C22	2561008060	1μF ±10% 100V FIXED METALIZED	SW4,5	2220661104	P.W. BOARD
C25	2533603008	10pF ±0.5pF 50V FIXED CERAMIC	SW6	2090042908	0.6 JUMPER WIRE SHORTLEAD USED 24
C26	2533603008	10pF ±0.5pF 50V FIXED CERAMIC	VR2	2050087026	2P. TERMINAL USED 3
C31	2551121096	0.039μF ±5% 50V FIXED PLASTIC FILM	VR3	2050087039	3P. TERMINAL USED 2
C32	2551121096	0.039μF ±5% 50V FIXED PLASTIC FILM	VR4	2050082034	3P. TERMINAL USED 3
C33	2551122095	0.27μF ±5% 50V FIXED PLASTIC FILM	VR5	2050082047	4P. TERMINAL USED 1
C34	2551122095	0.27μF ±5% 50V FIXED PLASTIC FILM	VR7	2124220007	2P. PUSH SWITCH
C37	2533633007	180pF ±5% 50V FIXED CERAMIC	VR8	2124264005	1P. PUSH SWITCH
C38	2533633007	180pF ±5% 50V FIXED CERAMIC	VR9	2110244000	VARIABLE RESISTOR 100 k ohm (VOLUME)
C39	2551120013	0.0012μF ±5% 50V FIXED PLASTIC FILM	VR10	2110245009	VARIABLE RESISTOR 250 k ohm (BALANCE)
C40	2551120013	0.0012μF ±5% 50V FIXED PLASTIC FILM	VR1	2110246011	VARIABLE RESISTOR 100 k ohm (BASS)
			VR5	2110253004	VARIABLE RESISTOR 50 k ohm (TREBLE)
			VR7	2116025045	SEMI FIXED RESISTOR 2 k ohm
			VR8	2116025045	SEMI FIXED RESISTOR 2 k ohm
			VR9	2116025032	SEMI FIXED RESISTOR 100 k ohm
			VR10	2116025032	SEMI FIXED RESISTOR 100 k ohm
				EP-5667H1	TERMINAL FOR WRAPPING PIN USED 2
				4120785007	CONDENSER BRACKET
				4730354019	TAPPING SCREW (2) 3x8
				2050003000	3T LUG USED 1
				4610154009	CUSHION

DIAGRAM

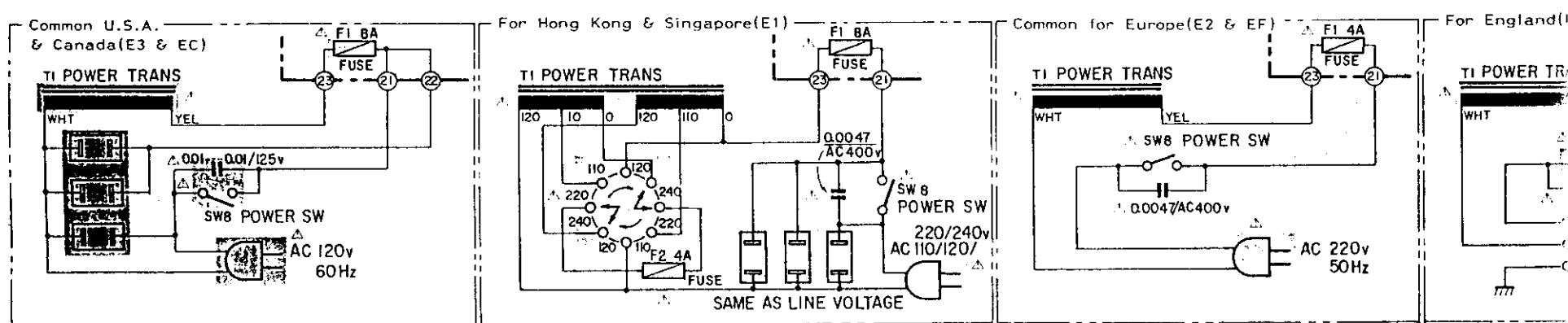
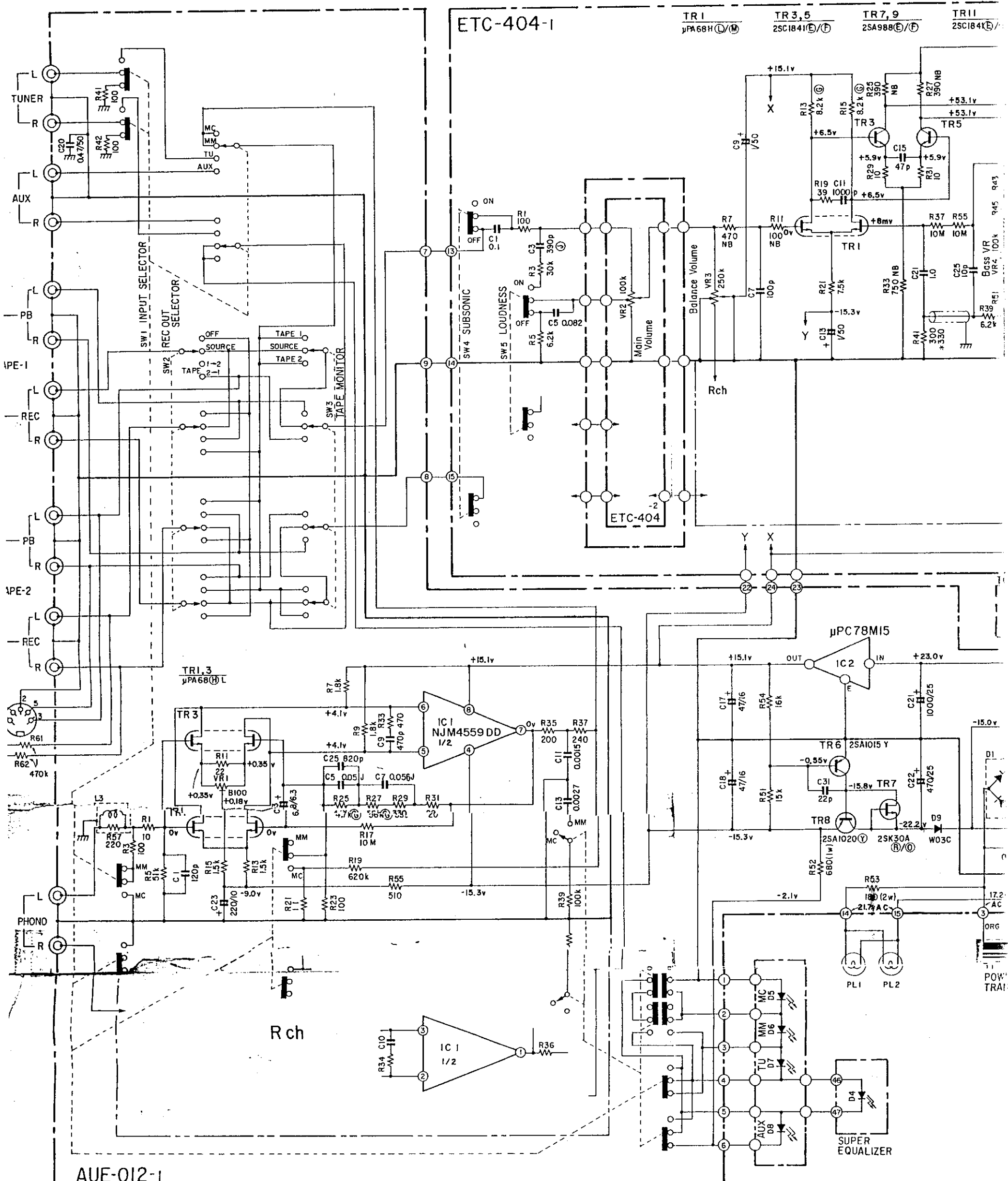

△ □ Means important safety item, which must be used when necessary, by a part specified or meeting the specification by the manufacturer.

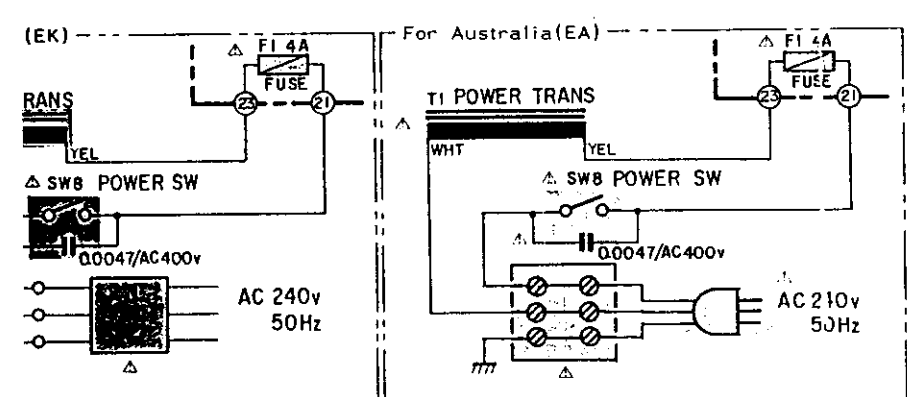
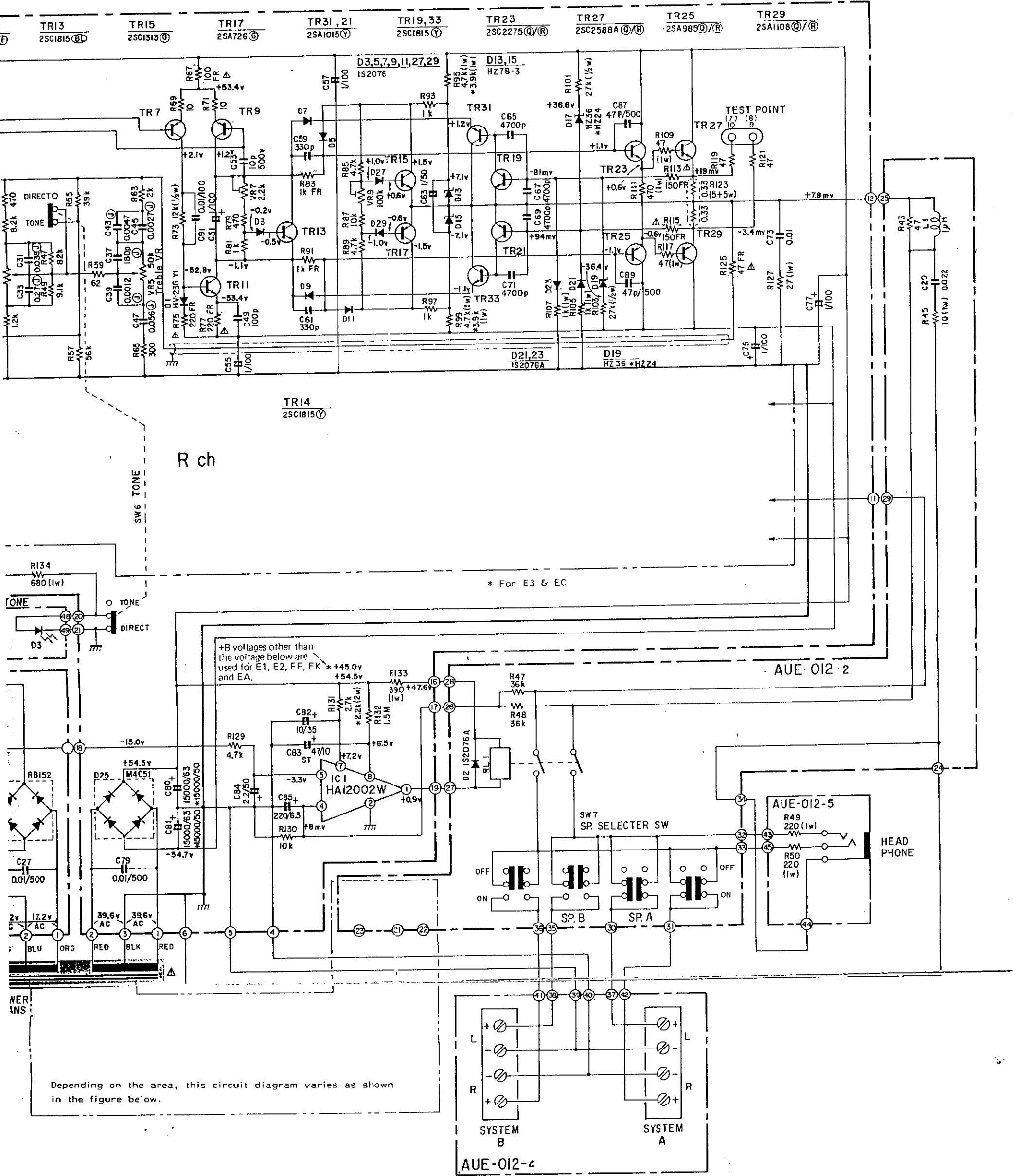

NOTES
 ALL RESISTANCE VALUES IN OHM K=1,000 OHM M=1,000,000 OHM
 ALL CAPACITANCE VALUES IN MICRO FARAD P=MICRO-MICRO FARAD
 EACH VOLTAGE AND CURRENT ARE MEASURED AT NO SIGNAL INPUT COND.
 CIRCUIT AND PARTS ARE SUBJECT TO CHANGE WITHOUT PRIOR NOTICE.

Depending on the area, this circuit diagram varies as shown in the figure below.

AUE-012-4

AUE-012-2

AUE-012-5

* For E3 & EC