

DENON

Hi-Fi Integrated Amplifier

SERVICE MANUAL MODEL PMA-700V

SOLID STATE
INTEGRATED AMPLIFIER



TABLE OF CONTENTS

SPECIFICATIONS	2
NAMES AND FUNCTIONS OF PARTS	3
REMOVAL OF EACH SECTION	4
CONNECTIONS	5
BLOCK DIAGRAM	7
METHOD OF ADJUSTMENTS	7
SEMICONDUCTORS	8
PRINTED WIRING BOARD PATTERNS AND PARTS LIST	
ETC9053B EQ. & P.S. UNIT	9
ETC9052B INPUT & POWER UNIT	10
WIRING DIAGRAM	14
SCHEMATIC DIAGRAM	17
EXPLODED VIEW OF CHASSIS AND CABINET & PARTS LIST	18

NIPPON COLUMBIA CO., LTD.

SPECIFICATIONS

POWER AMPLIFIER SECTION

Rated Output Power: Both channel drives (TUNER → SP OUT)
 100 Watts minimum rms per channel (8 ohm Load) with less than 0.02% total harmonic distortion from 20 Hz to 20 kHz.
 1 kHz (4 ohm Load) 150 W + 150 W (DIN, T.H.D 1%)
 1 kHz (6 ohm Load) 120 W + 120 W (IEC, Subject to change by temperature test)

Total Harmonic Distortion: 0.004% (20 Hz – 20 kHz at –3 dB rated output 8 ohm Load)
 0.0025% (1 kHz at rated output 8 ohm Load)

Input Sensitivity: 150 mV

Input Impedance: 30 k ohm

EQUALIZER AMPLIFIER SECTION

Equalizer Amplifier Output: (REC OUT Terminal) Rated Output: 150 mV

Input Sensitivity/Input Impedance:

PHONO MM	2.5 mV	47 k ohm
MC	200 μV	100 ohm

CD, VIDEO-1, VIDEO-2, TUNER/AUX, TAPE

	150 mV	30 k ohm
--	--------	----------

RIAA Deviation:

PHONO MM	within ±0.2 dB (20 Hz – 20 kHz)
MC	within ±0.3 dB (20 Hz – 100 kHz)

Maximum Input Voltage:

PHONO MM	160 mV/1 kHz
MC	12 mV/1 kHz

OVERALL CHARACTERISTICS

SN Ratio (IHFA Network): PHONO MM 94 dB (input terminals short-circuited for 5 mV input)
 MC 75 dB (input terminals short-circuited for 500 μV input)

TUNER/AUX, CD, TAPE, VIDEO-1, VIDEO-2

107 dB (input terminals short-circuited)

Tone Control Adjustable Range: BASS 100 Hz ±10 dB
 TREBLE 10 kHz ±10 dB

Filtering Characteristics: SUBSONIC 16 Hz, 12 dB/oct

Loudness Characteristics: Low frequency 100 Hz + 7 dB
 High frequency 10 kHz + 6 dB

AC OUTLET:

(For U.S.A., Canada and Asia)

SWITCHED x 2, 100 W (Total)
 UNSWITCHED x 1, 250 W

POWER SOURCE:

Germany and France AC 220 V, 50 Hz; U.K. and Australia AC 240 V, 50 Hz; U.S.A. and Canada AC 120 V, 60 Hz; Asia 110/120/220/240 V, 50/60 Hz (Multiple)

POWER CONSUMPTION:

3.8 A (U.S.A. & Canada); 220 W (IEC), 190W (Multiple)

DIMENSIONS:

434 mm (17-5/64")W x 157 mm (6-3/16")H x 397 mm (15-5/8")D (including rubber feet, control knobs, and terminals.)

WEIGHT:

10.5 kg (23 lbs 2 oz)

Design and specifications are subject to change without prior notice.

NOTE: The following codes correspond to the appropriate models.
 E3 for U.S.A., EA for Australia, EC for Canada
 This Service Manual is prepared based on E2 for Black Version.

For United Kingdom model only.

WARNING:

As the colours of the wires in the mains lead of this appliance may not correspond with the coloured markings identifying the terminals in your plug proceed as follows:

The wire which is coloured blue must be connected to the terminal which is marked with the letter N or coloured black.
 The wire which is coloured brown must be connected to the terminal which is marked with the letter L or coloured red.

The wire which is coloured BROWN must be connected to the terminal which is marked with the letter L or coloured RED.

IMPORTANT

The wires in this mains lead are coloured in accordance with the following code:

Blue: Neutral
 Brown: Live

For Australia model only.

FOR YOUR SAFETY

To ensure safe operation the three-pin plug supplied must be inserted only into a standard three-pin power point which is effectively earthed through the normal household wiring.

Extension cords used with the equipment must be three-core and be correctly wired to provide connection to earth. Wrongly wired extension cords are a major cause of fatalities.

The fact that the equipment operates satisfactorily does not imply that the power point is earthed and that the installation is completely safe. For your safety, if in any doubt about the effective earthing of the power point, consult a qualified electrician.

For U.S.A. and Canada models.

CAUTION

TO PREVENT ELECTRIC SHOCK DO NOT USE THIS (POLARIZED) PLUG WITH AN EXTENSION CORD, RECEPTACLE OR OTHER OUTLET UNLESS THE BLADES CAN BE FULLY INSERTED TO PREVENT BLADE EXPOSURE.

NAMES AND FUNCTIONS OF PARTS

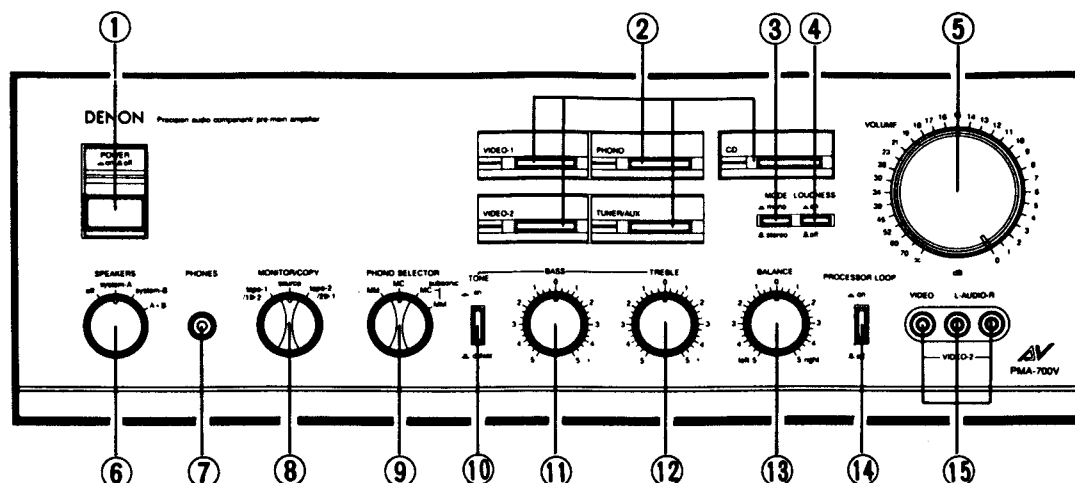

Fig. 1

- | | | | |
|---|--|---|--|
| ① | POWER and LED indicator
(Power supply button and LED indicator) | ⑦ | PHONES (Headphone Jack) |
| ② | INPUT SELECTOR (Input signal selection button)
● CD, ● PHONO, ● TUNER/AUX., ● VIDEO-1,
VIDEO-2 | ⑧ | MONITOR COPY (Tape monitor/Copy switch) |
| ③ | MODE (Mode button)
● Stereo, ● Mono | ⑨ | PHONO SELECTOR (Cartridge selection/Subsonic
filter switch) |
| ④ | LOUDNESS (Loudness button) | ⑩ | TONE (Tone switch) |
| ⑤ | VOLUME (Adjustment of the volume) | ⑪ | BASS (Regulation of low notes) |
| ⑥ | SPEAKERS (Speaker selection switch)
● system-A, ● system-B, ● A+B, ● off | ⑫ | TREBLE (Regulation of high notes) |
| | | ⑬ | BALANCE (Balance adjustment) |
| | | ⑭ | PROCESSOR LOOP (Processor loop switch) |
| | | ⑮ | FRONT VIDEO-2 (Extra front panel input terminal) |

Video Input Function

The PMA-700V provides a video input function. The image selection circuitry gives preference to VIDEO-1 for all settings of the INPUT SELECTOR button, unless VIDEO-2 has been specified. This function might be used, for example, to watch a TV monitor while playing a compact disc. In this case it would connect the image input circuitry of the VIDEO-1 terminal to the image output of a video recorder, tape recorder, or video disc recorder. The resultant monitor out signal would be sent to the TV monitor, for "background video" audio-visual entertainment combining sound and images.

Note:

Please note the following differences in the markings on the front and back panels on the European models:

VIDEO-1 → AUX/VIDEO 1
 VIDEO-2 → AUX/VIDEO 2
 TUNER/AUX → TUNER

In addition, there is no AV mark on the front panel.

REMOVAL OF EACH SECTION
 (When assembling, do reversely as to disassembling.)

1. Removal of Top Cover

- Remove 8 screws and detach the top cover as per arrow in Fig. 2.

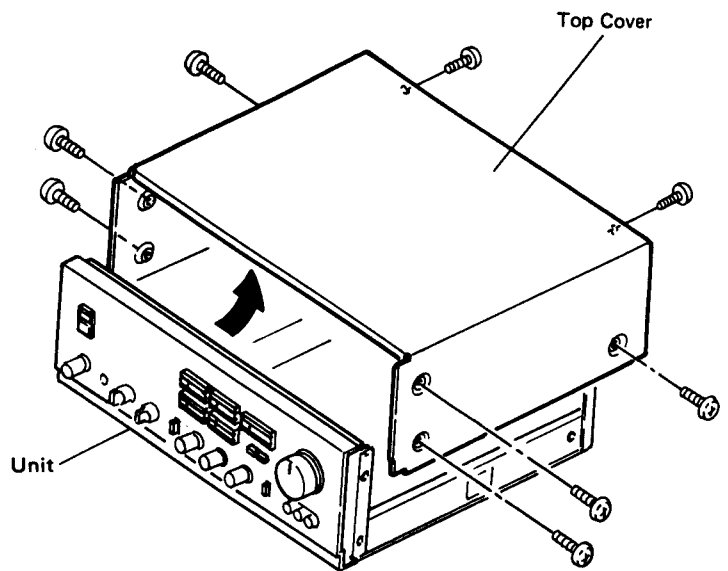

Fig. 2

2. Removal of Back Panel

- Remove 3 screws (A) and 7 screws (B) as per Fig. 3. Also remove screw (C) and detach back panel from the unit.

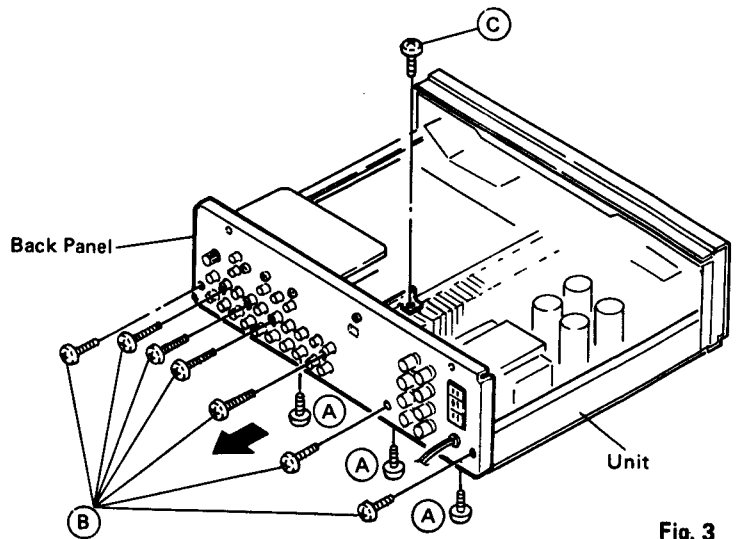

Fig. 3

3. Removal of Front Panel Ass'y

- Remove 4 screws (D) and remove 2 screws (E). And draw out front panel ass'y.

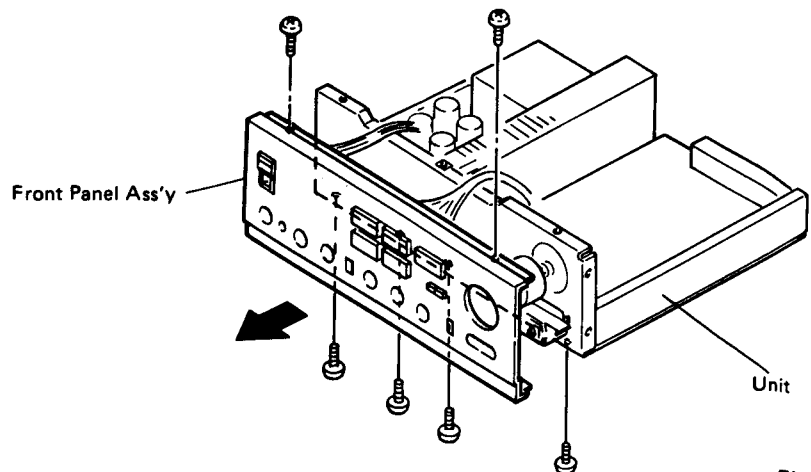
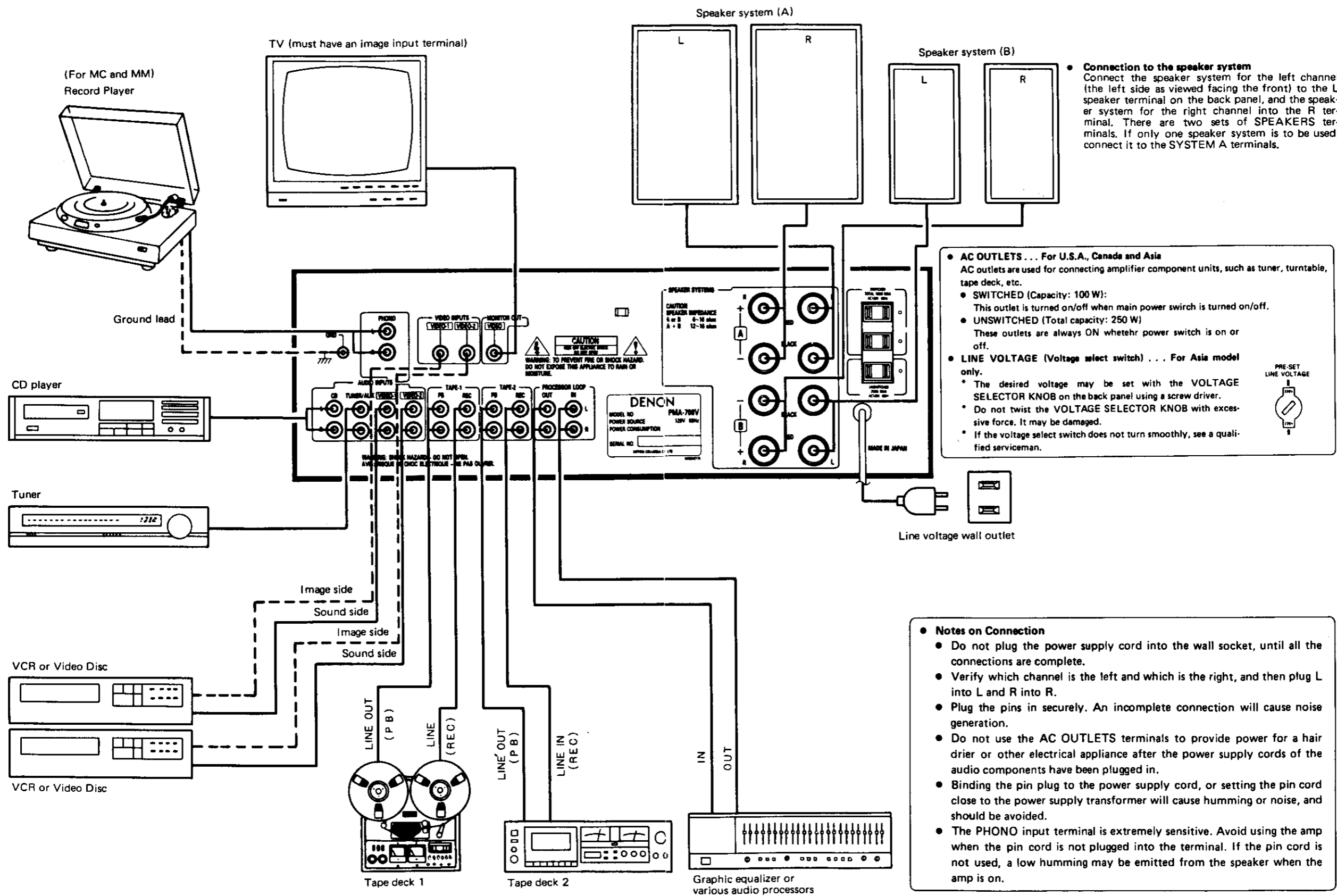

Fig. 4

CONNECTIONS



● **Connection to the speaker system**
 Connect the speaker system for the left channel (the left side as viewed facing the front) to the L speaker terminal on the back panel, and the speaker system for the right channel into the R terminal. There are two sets of SPEAKERS terminals. If only one speaker system is to be used, connect it to the SYSTEM A terminals.

● **AC OUTLETS . . . For U.S.A., Canada and Asia**
 AC outlets are used for connecting amplifier component units, such as tuner, turntable, tape deck, etc.
 ● **SWITCHED (Capacity: 100 W):**
 This outlet is turned on/off when main power switch is turned on/off.
 ● **UNSWITCHED (Total capacity: 250 W)**
 These outlets are always ON whether power switch is on or off.
 ● **LINE VOLTAGE (Voltage select switch) . . . For Asia model only.**
 * The desired voltage may be set with the VOLTAGE SELECTOR KNOB on the back panel using a screw driver.
 * Do not twist the VOLTAGE SELECTOR KNOB with excessive force. It may be damaged.
 * If the voltage select switch does not turn smoothly, see a qualified serviceman.

● **Notes on Connection**

- Do not plug the power supply cord into the wall socket, until all the connections are complete.
- Verify which channel is the left and which is the right, and then plug L into L and R into R.
- Plug the pins in securely. An incomplete connection will cause noise generation.
- Do not use the AC OUTLETS terminals to provide power for a hair drier or other electrical appliance after the power supply cords of the audio components have been plugged in.
- Binding the pin plug to the power supply cord, or setting the pin cord close to the power supply transformer will cause humming or noise, and should be avoided.
- The PHONO input terminal is extremely sensitive. Avoid using the amp when the pin cord is not plugged into the terminal. If the pin cord is not used, a low humming may be emitted from the speaker when the amp is on.

Fig. 5

- **Connecting a video device**
Connect the output terminals of the video device (OUTPUT) to the VIDEO terminals of the amp, using a pin plug cord.

• **CONNECTING A VIDEO DEVICE**

< Video Disc Player >

< TV (must have image input terminal) >

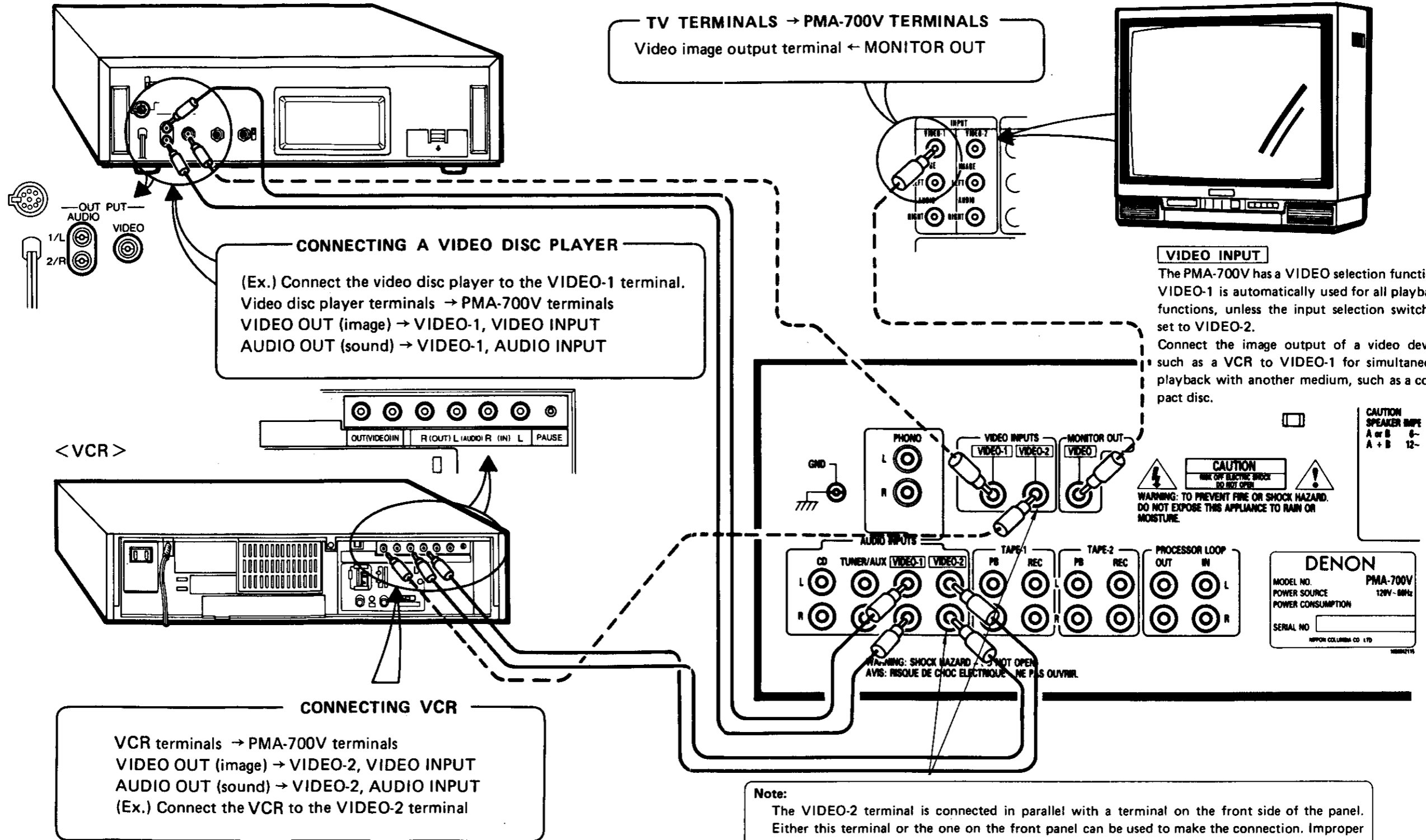

Fig. 6

BLOCK DIAGRAM

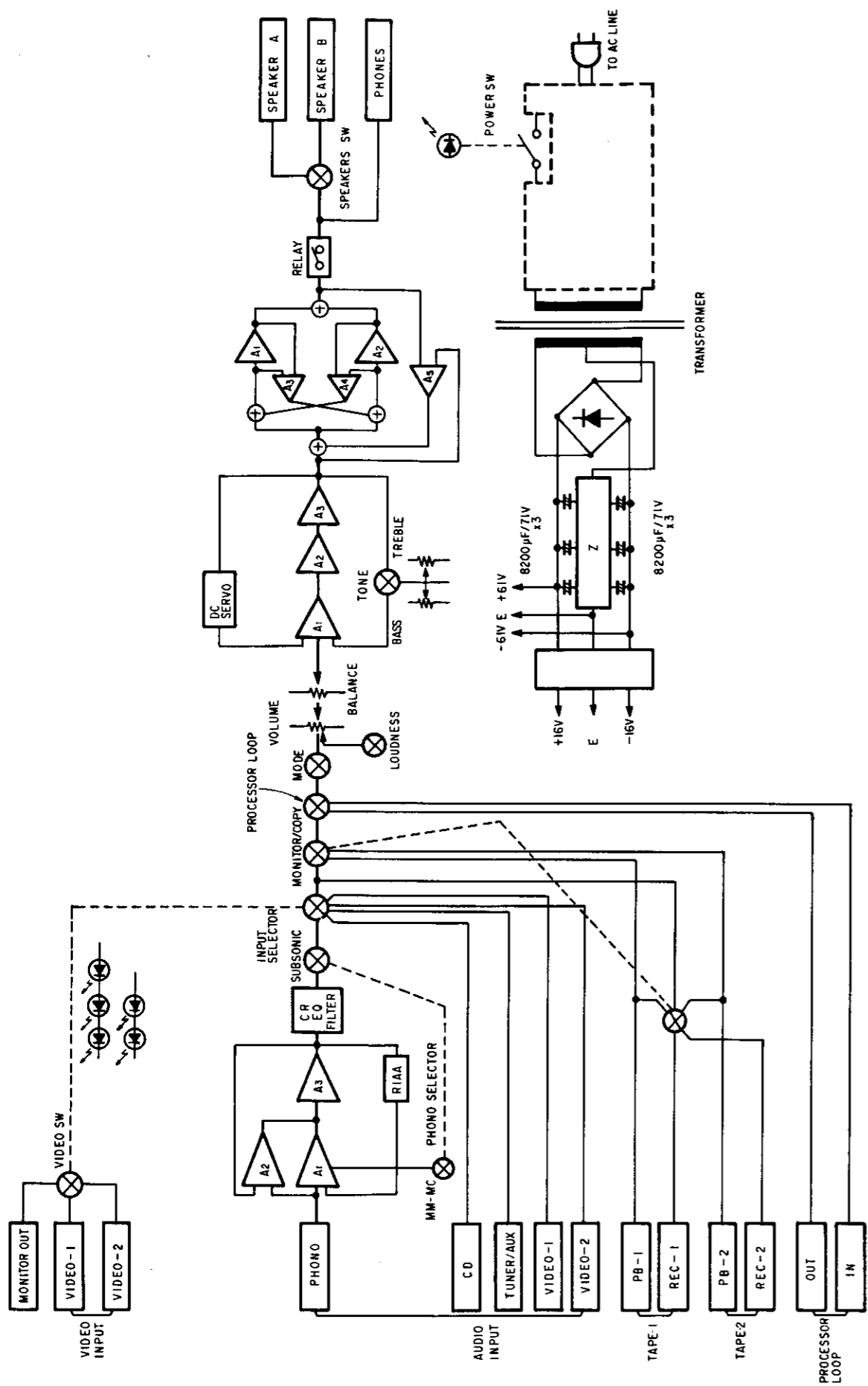

Fig. 7

METHOD OF ADJUSTMENTS

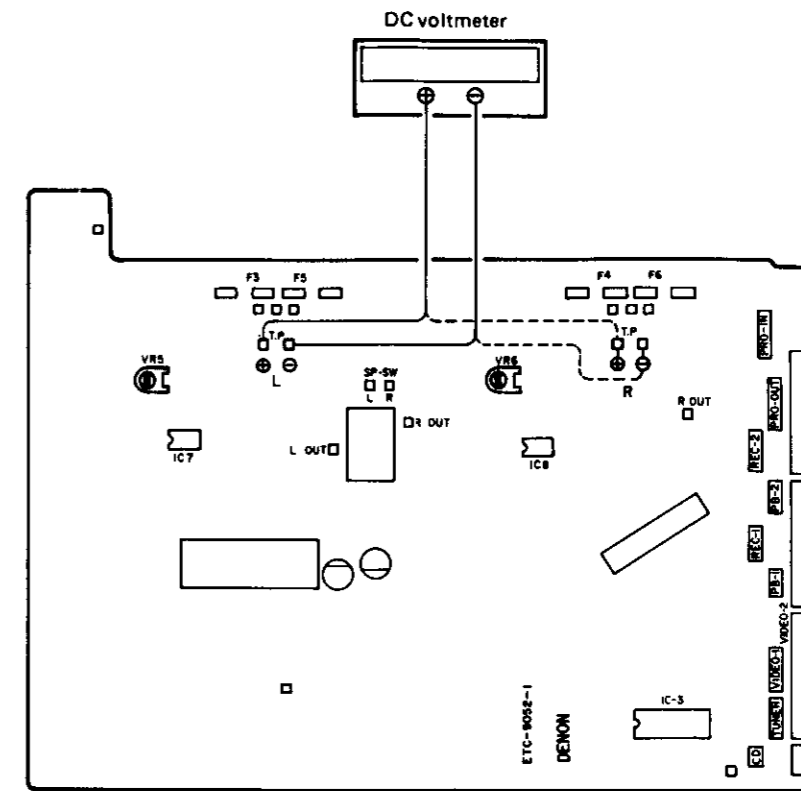

Fig. 8

IDLING CURRENT

• Setup

1. Lay the unit at an ordinary position away from a direct current from a cooler or fan. Do the adjustment at a temperature between 15°C and 30°C.
2. Set controls as follows.
 - POWER SWITCH → off ()
 - VOLUME CONTROL → fully counterclockwise (min)
 - SPEAKER Terminals → open: do not connect the speakers, dummy load etc.

• Adjustment

1. Remove Top cover. And then connect DC Voltmeter to Test points of ETC-9052-1 (INPUT & POWER Unit).
2. Connect Power cord to AC outlet, and turn Power Switch "on" (). Within 10 seconds turn VR5 (Lch) and VR6 (Rch) clockwise so that the DC voltmeter reads.
 - 0.4 ± 0.1 mVDC
3. Then after 5 minutes warmup adjust VR5 and VR6 so that the DC Voltmeter reads.
 - 5 ± 0.5 mV
4. And after 15 minutes warmup adjust VR5 and VR6 so that the DC Voltmeter reads.
 - 8 ± 3 mV

SEMICONDUCTORS

• IC's

FUNCTION OF EACH TERMINAL

TC9152P (Toshiba)

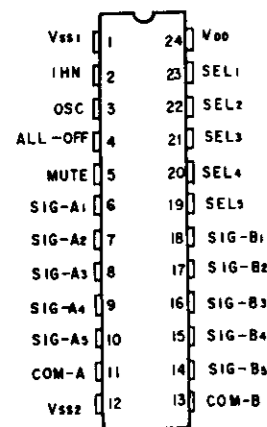

TERMINAL NO.	SYMBOL	FUNCTION	REMARKS
2	INH	Inhibit input terminal. Normal operation at "H" level, inhibit operation at "L" level.	
3	OSC	C.R connecting terminal for oscillator. With this oscillation frequency, muting time and switching time of analog will be set.	
4	ALL-OFF	Specified OFF input terminal of all analog switches. Applying "H" level to turn off all analog switches.	
5	MUTE	Output terminal of muting signal. By receiving of "H" level at select input terminals (SEL-1 ~ SEL-5), this terminal becomes "H" level for settled time and within this time analog switch will shift.	
23 22 21 20 19	SEL-1 SEL-2 SEL-3 SEL-4 SEL-5	Select input terminals for respective analog switches. Turn SEL-1 ~ SEL-5 terminals to "H" level to turn on respective analog switches. SEL-1 ~ SEL-5 are all reciprocal reset. These terminals are in conjunction with driver output I/O terminals.	
6/18	SIG-A ₁ SIG-B ₁	Signal input terminal 1. Select SEL-1 to turn on analog switch 1 and this terminal will conduct to COM terminal.	
7/17	SIG-A ₂ SIG-B ₂	Signal input terminal 2. Select SEL-2 to turn on analog switch 2 and this terminal will conduct to COM terminal.	
8/16	SIG-A ₃ SIG-B ₃	Signal input terminal 3. Select SEL-3 to turn on analog switch 3 and this terminal will conduct to COM terminal.	
9/15	SIG-A ₄ SIG-B ₄	Signal input terminal 4. Select SEL-4 to turn on analog switch 4 and this terminal will conduct to COM terminal.	
10/14	SIG-A ₅ SIG-B ₅	Signal input terminal 5. Select SEL-5 to turn on analog switch 5 and this terminal will conduct to COM terminal.	
11/13	COM-A COM-B	Common terminal for analog switches.	
24 1 12	VDD V _{SS1} V _{SS2}	Power supply voltage applying terminal. For control system VDD-V _{SS1} . For analog switch system VDD-V _{SS2} .	

M5218P (Mitsubishi)
LA6458DF (Sanyo)

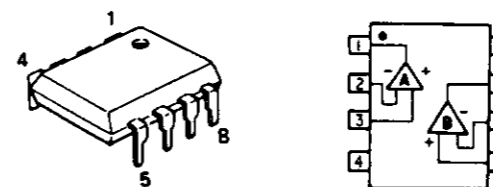

• TRANSISTORS (including FET)

- 2SA1015(Y)
2SC1815(BL)
2SC2878(A/B)
2SA988(E/F)
2SC1841(E/F)
- 2SA949(O/Y)
2SC2229(O/Y)
- 2SA1358(Y/O) (Green)
2SC3421(Y/O) (Black)
- 2SA1104(O)/(Y)
2SC2579(O)/(Y)
- 2SA1306(O/Y) (Green)
2SC3298(O/Y) (Black)
- FET 2SK381(C)/(D)
- FET 2SK369(BL)/(GR)-C
2SK170(BL/V)-DVGS

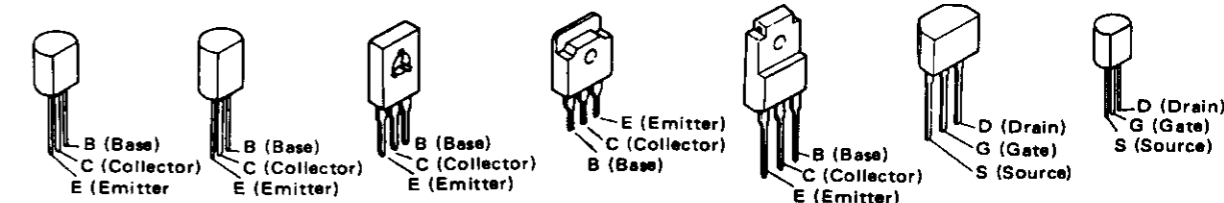

• DIODES (including LED)

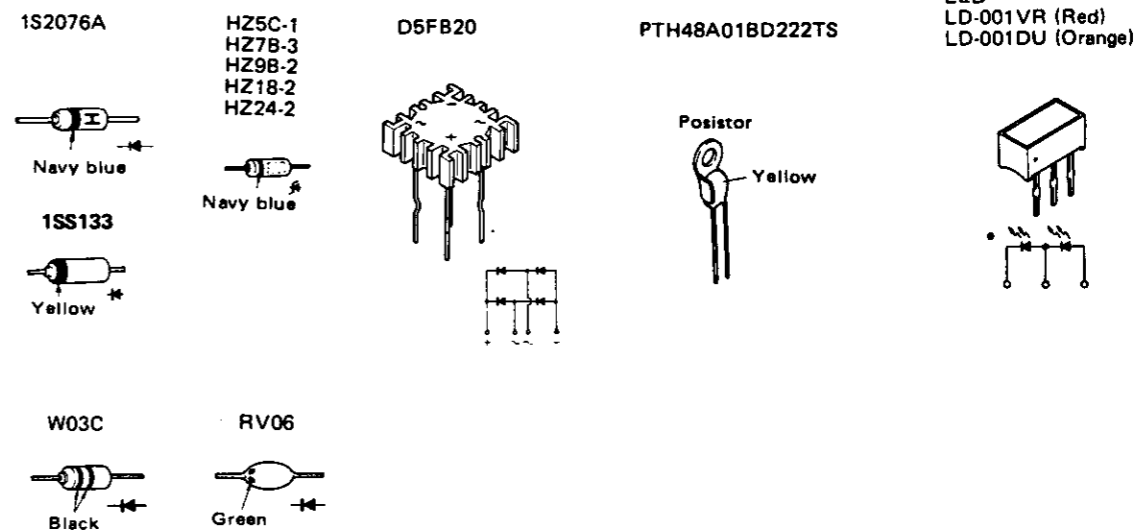

PRINTED WIRING BOARD PATTERNS AND PARTS LIST

ETC9053B EQ. & PS UNIT

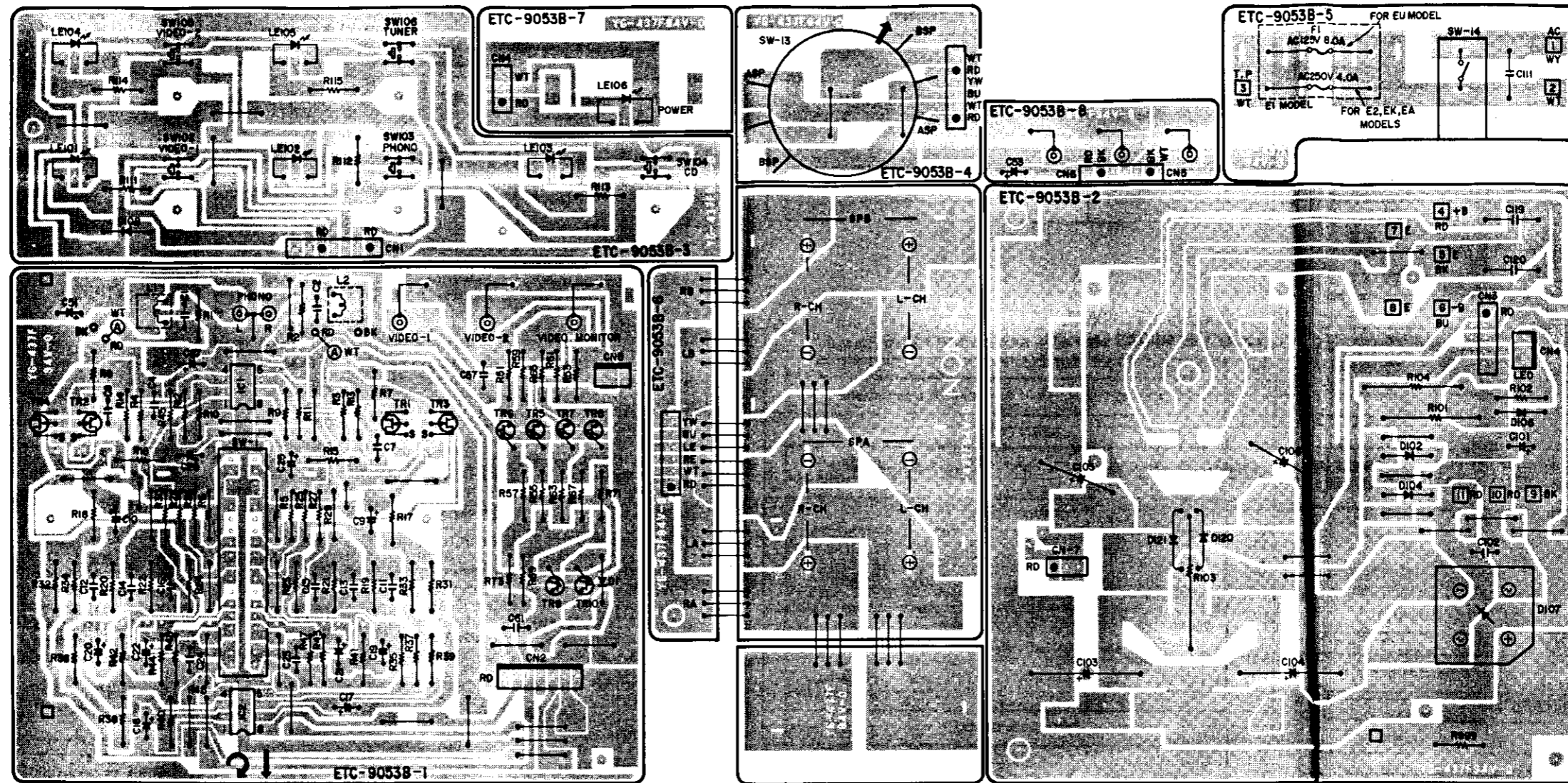

ETC9053B EQ. & PS UNIT PARTS LIST

Ref. No.	Part No.	Part Name & Descriptions	
SEMICONDUCTORS			
IC001	2630257001	M-5218P	IC (MITSUBISHI)
IC002	2630229013	LA-6848DF	IC (SANYO)
TR001 ~004	2750038045	2SK369(BL)/(GR)-C	FET
TR005	2710102005	2SA1015(Y)	TRANSISTOR
TR006	2730198015	2SC1815(BL)	TRANSISTOR
TR007	2710102005	2SA1015(Y)	TRANSISTOR
TR008 ~010	2730198015	2SC1815(BL)	TRANSISTOR
D001	2760220021	HZ24-2	ZENER
D102 ~104	2760191008	W03C	DIODE
D106	2760249002	HZ18-2	ZENER
D107	2760356005	D5F820(4001)	DIODE
D108	2760249002	HZ18-2	ZENER
D120, 121	2760237001	RV06	DIODE
LE101 ~105	3939310004	LD-001VR	LED (INPUT)
LE106	3939310017	LD-001DU	LED (POWER)
RESISTORS (not included Carbon Film ±5%, 1/4W type)			
AR101	2440103028	2.7k ohm ±5%	2W METAL OXIDE FILM (NBF)
AR103	2430032002	0.47 ohm ±5%	3W METAL OXIDE FILM (NBF)
AR104	2440103028	2.7k ohm ±5%	2W METAL OXIDE FILM (NBF)

Ref. No.	Part No.	Part Name & Descriptions	
CAPACITORS			
C001, 002	2533631009	150pF ±5%	50V CERAMIC
C007, 008	2551134025	0.01μF ±5%	50V PLASTIC FILM
C009, 010	2544161021	100μF ±20%	6.3V ELECTROLYTIC
C011, 012	2551140048	0.068μF ±5%	50V PLASTIC FILM
C013, 014	2551140035	0.018μF ±5%	50V PLASTIC FILM
C015, 016	2554149004	1500pF ±5%	50V PLASTIC FILM
C017, 108	2544161021	100μF ±20%	6.3V ELECTROLYTIC
C019, 020	2544147003	2.2μF	50V ELECTROLYTIC
C021, 022	2544146004	1μF	50V ELECTROLYTIC
C023, 024	2554157009	3300pF ±5%	50V PLASTIC FILM
C025	2544146004	1μF	50V ELECTROLYTIC
C027	2544146004	1μF	50V ELECTROLYTIC
C029	2544130007	100μF	10V ELECTROLYTIC
C031, 032	2544114007	10μF ±20%	35V ELECTROLYTIC
C051	2544146004	1μF	50V ELECTROLYTIC
C053	2544146004	1μF	50V ELECTROLYTIC

Ref. No.	Part No.	Part Name & Descriptions		Q'ty
C057	2531024003	0.01μF	+80,-20% 50V CERAMIC	
C061	2531024003	0.01μF	+80,-20% 50V CERAMIC	
C101	2544060009	10μF	100V ELECTROLYTIC	
C102	2538011006	0.01μF	+80%-20% 250V (AC) CERAMIC	
C103 ~106	2546084009	8200μF	±20% 63V ELECTROLYTIC	
AC111	2538003014	0.0047μF	+100,-0% 400V (AC) CERAMIC	
C591 ~594	2531008003	4700pF	±10% 50V CERAMIC	
SWITCHES & COILS				
SW001	2129521002	SLIDE SW REMOTE (PHONO)		
SW013	2129522001	ROTARY SWITCH (SPEAKER)		
ASW014	2129525008	POWER SWITCH		
SW102 ~106	2124407008	TACT SWITCH (INPUT)		
L001, 002	2359003002	FTZ CHOKE COIL		
OTHER PARTS				
	2229054107	P.W. BOARD		1
	2090008120	JUMPER WIRE P=10mm		60
	EP-5667H1	TERMINAL PIN L=21mm		10
	2020022008	FUSE HOLDER		2
AF001	2061015087	FUSE (4A) (MINI SIZE WITHSTAND RUSH)		1

Ref. No.	Part No.	Part Name & Descriptions		Q'ty
	2050274004	2P CONNECTOR BASE		1
	2050240009	3P CONNECTOR BASE		1
	2048182014	3P CONNECTOR BASE		1
	2050273005	4P TERMINAL		2
	4450057010	CORD CLIP		2
CN001	2042052098	7P NH CONNECTOR CORD (TACT SW & LED)		1
CN002	2050190078	7P NH CONNECTOR BASE (EQ & VIDEO SW)		1
CN003	2038123067	5P NH CONNECTOR CORD (+ - B & MUTING)		1
CN003	2050185054	5P WIRE HOLDER (+ - & MUTING)		1
CN004	2050190036	3P NH CONNECTOR BASE (F-VIDEO)		1
CN004	2034185012	3P CONNECTOR CORD (POWER LED)		1
CN004	2050185038	3P WIRE HOLDER (POWER LED)		1
CN005	2050190036	3P NH CONNECTOR BASE (PO-LED)		1
CN005	2034282009	3P CONNECTOR CORD (FRONT VIDEO-2)		1
CN006	2034200023	3P CONNECTOR CORD (F. VIDEO-2, BK)		1
	2050185067	6P WIRE HOLDER (VDIEO-2)		3
	2050243077	7P WIRE HOLDER (TACT SW & LED)		1
	2030241028	1P CONTACT ASS'Y (FRONT VIDEO-2)		1

E1, EP1 for Asia ETC9053D
(Same as ETC9053B (for E2) except the followings.)

Ref. No.	Part No.	Part Name & Descriptions
RESISTORS		
R001, 002	2412100004	2.2k ohm ±5% 1/4W CARBON DELETE
R047, 048	2412128002	33k ohm ±5% 1/4W CARBON ADD.
CAPACITORS		
C031, 032	2544141009	10µF 35V ELECTROLYTIC ADD.
ΔCT11	2538010007	0.01µF +100,-0% 400V (AC) CERAMIC DELETE
C591 ~594	2531008003	4700pF ±10% 50V CERAMIC DELETE
SWITCH & COILS		
ΔSW014	2129525008	POWER SWITCH DELETE
L001, 002	2359003002	FTZ CHOKE COIL (2) DELETE
OTHER PARTS		
	2020022008	FUSE HOLDER (2) DELETE
ΔF001	2061015087	FUSE 4A DELETE

EU for U.S.A. ETC9053E
(Same as ETC9053B (for E2) except the followings.)

Ref. No.	Part No.	Part Name & Descriptions
RESISTORS		
R001, 002	2412100004	2.2k ohm ±5% 1/4W CARBON DELETE
CAPACITORS		
C001, 002	2554121006	100pF ±5% 50V PLASTIC FILM ADD.
C001, 002	2533631009	150pF ±5% 50V CERAMIC DELETE
ΔC111	2538010007	0.01µF +100,-0% 400V (AC) CERAMIC DELETE
C111	2538011006	0.01µF +80,-20% 250V (AC) CERAMIC ADD.
C591 ~594	2531008003	4700pF ±10% 50V CERAMIC DELETE
SWITCH & COILS		
ΔSW014	2129525008	POWER SWITCH DELETE
L001, 002	2359003002	FTZ CHOKE COIL (2) DELETE
OTHER PARTS		
ΔF001	2001015087	FUSE 4A DELETE
	2020022008	FUSE HOLDER (2) DELETE

EK for U.K. and EA for Australia ETC9053F
(Same as ETC9053B (for E2) except the followings.)

Ref. No.	Part No.	Part Name & Descriptions
RESISTORS		
R001, 002	2412100004	2.2k ohm ±5% 1/4W CARBON DELETE
SWITCH & COILS		
L001, 002	2359003002	FTZ CHOKE COIL (2) DELETE

EC for Canada ETC9053L
(Same as ETC9053B (for E2) except the followings.)

Ref. No.	Part No.	Part Name & Descriptions
RESISTORS		
R001, 002	2412100004	2.2k ohm ±5% 1/4W CARBON DELETE
CAPACITORS		
C001, 002	2554121006	100pF ±5% 50V PLASTIC FILM ADD.
C001, 002	2533631009	150pF ±5% 50V CERAMIC DELETE
ΔC111	2538010007	0.01µF +100,-0% 400V (AC) CERAMIC DELETE
C111	2538011006	0.01µF +80,-20% 250V (AC) CERAMIC ADD.
C591 ~594	2531008003	4700pF ±10% 50V CERAMIC DELETE
SWITCH & COILS		
ΔSW014	2129525008	POWER SWITCH DELETE
L001, 002	2359003002	FTZ CHOKE COIL (2) DELETE
OTHER PARTS		
ΔF001	2001015087	FUSE 4A DELETE
	2020011008	FUSE HOLDER (2) DELETE

ETC9052B INPUT & POWER UNIT PARTS LIST

Ref. No.	Part No.	Part Name & Descriptions
SEMICONDUCTORS		
IC003	2620581004	TC9152P IC (TOSHIBA)
IC005 ~008	2630257001	M-5218P IC (MITSUBISHI)
TR151	2730198015	2SC1815(BL) TRANSISTOR
TR152	2710102005	2SA1015(Y) TRANSISTOR
TR153	2730198015	2SC1815(BL) TRANSISTOR
TR155, 156	2730253015	2SC2878(A/B) TRANSISTOR
TR201, 202	2730198015	2SC7815(BL) TRANSISTOR
TR203	2730235020	2SC1841(E/F) TRANSISTOR
TR204	2710102005	2SA1015(Y) TRANSISTOR
TR205	2730253015	2SC2878(A/B) TRANSISTOR
TR206, 207	2730198015	2SC1815(BL) TRANSISTOR
TR208	2710102005	2SA1015(Y) TRANSISTOR
TR209	2730323000	2SC3421(O/Y) TRANSISTOR
TR210	2710195009	2SA1358(O/Y) TRANSISTOR
TR211, 212	2750043001	2SK381(B)/(C) FET
TR401 ~404	2750046008	2SK170(BL/V)DVGS FET
TR405 ~408	2730235020	2SC1841(E/F) TRANSISTOR
TR409 ~414	2710185006	2SA949(O)/(Y) TRANSISTOR
TR415, 416	2730307000	2SC2229(O)/(Y) TRANSISTOR
TR417, 418	2710185006	2SA949(O)/(Y) TRANSISTOR
TR419, 420	2730307000	2SC2229(O)/(Y) TRANSISTOR
TR501, 502	2730198015	2SC1815(BL) TRANSISTOR
TR503, 504	2730307000	2SC2229(O)/(Y) TRANSISTOR
TR505, 506	2710185006	2SA949(O)/(Y) TRANSISTOR
TR507, 508	2730324009	2SC3298(O/Y) TRANSISTOR
TR509, 510	2710196008	2SA1306(O/Y) TRANSISTOR
D152, 153	2760401002	1S5133 DIODE
D171 ~173	2760401002	1S5133 DIODE
D201	2760049011	1S2076A DIODE
D202	2760249002	HZ18-2 ZENER
D208	2760049011	1S2076A DIODE
D401 ~406	2760401002	1S5133 DIODE
D501 ~504	2760218033	HZ9B-2 ZENER
D505, 506	2760236031	HZ5C-1 ZENER
D507 ~510	2760254000	HZ7B-3 ZENER
D511 ~522	2760401002	1S5133 DIODE
D523 ~526	2760049011	1S2076A DIODE
D527 ~530	2760401002	1S5133 DIODE
D531, 532	2760049011	1S2076A DIODE
RESISTORS (not included Carbon Film ±5%, 1/4W Type)		
ΔR201, 202	2440038025	560 ohm ±5% 1W METAL OXIDE FILM (NBF)
ΔR207	2440037026	470 ohm ±5% 1W METAL OXIDE FILM (NBF)
ΔR413 ~416	2412369094	240 ohm ±5% 1/4W CARBON (NBF)
ΔR421, 422	2412379987	1k ohm ±5% 1/4W CARBON (NBS)

Ref. No.	Part No.	Part Name & Descriptions
ΔR423, 424	2412378984	47 ohm ±5% 1/4W CARBON (NBS)
ΔR429 ~432	2412377947	100 ohm ±5% 1/4W CARBON (NBS)
ΔR433	2412378984	47 ohm ±5% 1/4W CARBON (NBS)
ΔR434	2412321061	47 ohm ±5% 1/4W CARBON (NBF)
ΔR435 ~438	2412378984	47 ohm ±5% 1/4W CARBON (NBS)
ΔR501 ~508	2440043023	1.5k ohm ±5% 1W METAL OXIDE FILM (NBF)
ΔR545 ~548	2412378987	1k ohm ±5% 1/4W CARBON (NBS)
ΔR549, 550	2412314023	470 ohm ±5% 1/4W CARBON (NBF)
ΔR551 ~554	2412377947	100 ohm ±5% 1/4W CARBON (NBS)
ΔR559, 560	2412321045	220 ohm ±5% 1/4W CARBON (NBF)
ΔR561 ~566	2440013024	4.7 ohm ±5% 1W METAL OXIDE FILM (NBF)
ΔR567 ~574	2442013080	0.22 ohm ±5% 1W METAL OXIDE FILM (NBF)
ΔR585, 586	2440021029	22 ohm ±5% 1W METAL OXIDE FILM (NBF)
ΔR587, 588	2440021029	22 ohm ±5% 1W METAL OXIDE FILM (NBF)
ΔR589, 590	2440013024	4.7 ohm ±5% 1W METAL OXIDE FILM (NBF)
ΔR591, 592	2440030023	120 ohm ±5% 1W METAL OXIDE FILM (NBF)
ΔR595, 596	2412321003	1k ohm ±5% 1/4W CARBON (NBF)
VR001	2119020005	MAIN VR 100k ohm
VR002	2119021004	BALANCE VR 200k ohm
VR003	2119022016	BASS VR 250k ohm
VR004	2119022003	TREBLE VR 50k ohm
VR005, 006	2116000099	SEMIFIXED RESISTOR BIAS (2k ohm)
CAPACITORS		
C055	2544132005	10µF 16V ELECTROLYTIC
C059	2544146004	1µF 50V ELECTROLYTIC
C151	2551001006	0.001µF ±5% 50V PLASTIC FILM
C155	2544164031	220µF ±20% 25V ELECTROLYTIC
C157	2531024003	0.01µF +80,-20% 50V CERAMIC
C171	2544146004	1µF 50V ELECTROLYTIC
C201, 202	2544146004	1µF 50V ELECTROLYTIC
C203	2554137003	470pF ±5% 50V PLASTIC FILM
C204	2544141009	10µF 35V ELECTROLYTIC
C205	2544127007	220µF 6.3V ELECTROLYTIC
C206	2544006005	470µF 6.3V ELECTROLYTIC
C207	2544132005	10µF 16V ELECTROLYTIC
C301, 302	2531004007	1000pF ±10% 50V CERAMIC
C303, 304	2551140051	0.082µF ±5% 50V PLASTIC FILM
C401, 402	2554121006	100pF ±5% 50V PLASTIC FILM
C403, 404	2554137003	470pF ±5% 50V PLASTIC FILM
C405, 406	2531008003	4700pF ±10% 50V CERAMIC
C407, 408	2534269001	10pF ±0.5pF 500V CERAMIC
C409, 410	2531024003	0.01µF +80,-20% 50V CERAMIC
C411, 412	2534355009	5pF ±0.25pF 500V CERAMIC
C413, 414	2533627000	100pF ±5% 50V CERAMIC
C415, 416	2533643000	470pF ±5% 50V CERAMIC
C417, 418	2544150003	10µF 50V ELECTROLYTIC

Ref. No.	Part No.	Part Name & Descriptions	Ref. No.	Part No.	Part Name & Descriptions	Q'ty
C419, 420	2534273000	15pF ±5% 500V CERAMIC	F003 ~006	2020022008	FUSE HOLDER (+ - B)	8
C421, 422	2534271002	12pF ±0.5pF 500V CERAMIC		2050274004	2P CONNECTOR BASE	1
C425, 426	2544146004	1μF 50V ELECTROLYTIC	CN001	2050152003	6P CONNECTOR BASE	3
C427	2544060038	0.47μF 100V ELECTROLYTIC		2050190078	7P NH CONNECTOR BASE (TACT SW & LED)	1
C428	2544181001	1μF ±20% 100V ELECTROLYTIC	CN002	2050185070	7P WIRE HOLDER	1
C429, 430	2544161021	100μF ±20% 6.3V ELECTROLYTIC	CN002	2042052014	7P CONNECTOR CORD (EQ & VIDEO SW)	1
C451, 452	2551121041	0.015μF ±5% 50V PLASTIC FILM	CN003	2050190052	5P NH CONNECTOR BASE	1
C453, 454	2551140064	0.12μF ±5% 50V PLASTIC FILM	CN006	2050190036	3P NH CONNECTOR BASE (FRONT VIDEO-2)	1
C457, 458	2551121007	6800pF ±5% 50V PLASTIC FILM		2050190036	3P NH CONNECTOR BASE (POWER INPUT)	1
C459, 460	2551120013	1200pF ±5% 50V PLASTIC FILM	W-003	2050185038	3P WIRE HOLDER	13
C461, 462	2551135095	0.056μF ±5% 50V PLASTIC FILM		2034200010	3P CONNECTOR CORD	1
C465, 466	2533633007	180pF ±5% 50V CERAMIC	F003 ~006	4450033005	WIRE CLAMP BAND	1
C501 ~504	2544139008	100μF 25V ELECTROLYTIC		2061040023	FUSE (6.3A, F)	4
C505, 506	2533603008	10pF ±0.5pF 50V CERAMIC				
C507 ~510	2533639001	330pF ±5% 50V CERAMIC				
C511, 512	2544132005	10μF 16V ELECTROLYTIC				
C513, 514	2544146004	1μF 50V ELECTROLYTIC				
C519 ~522	2531024003	0.01μF +80,-20% 50V CERAMIC				
C523 ~526	2531024003	0.01μF +80,-20% 50V CERAMIC				
C527 ~530	2533627000	100pF ±5% 50V CERAMIC				
C531 ~534	2534281005	33pF ±5% 500V CERAMIC				
C535 ~538	2531005006	1500pF ±10% 50V CERAMIC				
C539, 540	2551121025	0.01μF ±5% 50V PLASTIC FILM				
C541, 542	2551121067	0.022μF ±5% 50V PLASTIC FILM				
C543 ~546	2544181001	1μF ±20% 100V ELECTROLYTIC				
C555, 556	2531024003	0.01μF +80,-20% 50V CERAMIC				
C555, 556	2531024003	0.01μF +80,-20% 50V CERAMIC				
SWITCHES & RELAY						
SW007	2124254002	SLIDE SW (REMOTE) T. MONI				
SW008	2129520003	1P PUSH SW PROCESSOR LOOP				
SW010, 011	2129523000	2P PUSH SW MODE & LOUD				
SW012	2129520003	1P PUSH SW TONE				
RL001	2140037009	RELAY SP 48V				
OTHER PARTS						Q'ty
J701 ~703 705	2229053302	P.W. BOARD				1
	2090008146	JUMPER WIRE P=5mm				15
	2090008120	JUMPER WIRE P=10mm				219
	2090008104	JUMPER WIRE P=15mm				4
J018	2090008159	JUMPER WIRE P= mm				1
	EP-5667H1	TERMINAL PIN L=21mm				12
	4170043100	RADIATOR (FOR TR209, 210)				2
	4730354019	TAPPING SCREW (2) 3x8				2
L501, 502	2359001004	INDUCTOR (1μH)				2
	4140240001	EARTH PLATE (GND)				1
	2048191005	HEADPHONE JACK				1

E1, EP1 for Asia ETC9052D

(Same as ETC9052B (for E2) except the followings.)

Ref. No.	Part No.	Part Name & Descriptions			
RESISTORS					
R207	2440037026	470 ohm	±5%	1W	METAL OXIDE CHANGE
R525, 526	2412123007	20k ohm	±5%	1/4W	CARBON CHANGE
CAPACITORS					
C507 ~510	2533639001	330pF	±5%	50V	CERAMIC CHANGE
OTHER PARTS					
F003 ~006	2090008120 2061041035	JUMPER WIRE P=10mm (4) FUSE (F) 6.3A (4)			ADD. CHANGE

EU for U.S.A. ETC9052E

(Same as ETC9052B (for E2) except the followings.)

Ref. No.	Part No.	Part Name & Descriptions			
OTHER PARTS					
F003 ~006	5139134004 2061046001	FUSE LABEL FUSE 6.3AUL ℓ=20mm			ADD. CHANGE

EK for U.K. and EA for Australia ETC9052F

(Same as ETC9052B (for E2) except the followings.)

Ref. No.	Part No.	Part Name & Descriptions			
CAPACITORS					
C424	2544060038	0.47μF		100V	ELECTROLYTIC ADD.
C427	2544060038	0.47μF		100V	ELECTROLYTIC DELETE

EC for Canada ETC9052L

(Same as ETC9052B (for E2) except the followings.)

Ref. No.	Part No.	Part Name & Descriptions			
F003 ~006	5139134004 2061046001	FUSE LABEL FUSE 6.3AUL ℓ=20mm			ADD CHANGE

ETC9052B INPUT & POWER UNIT

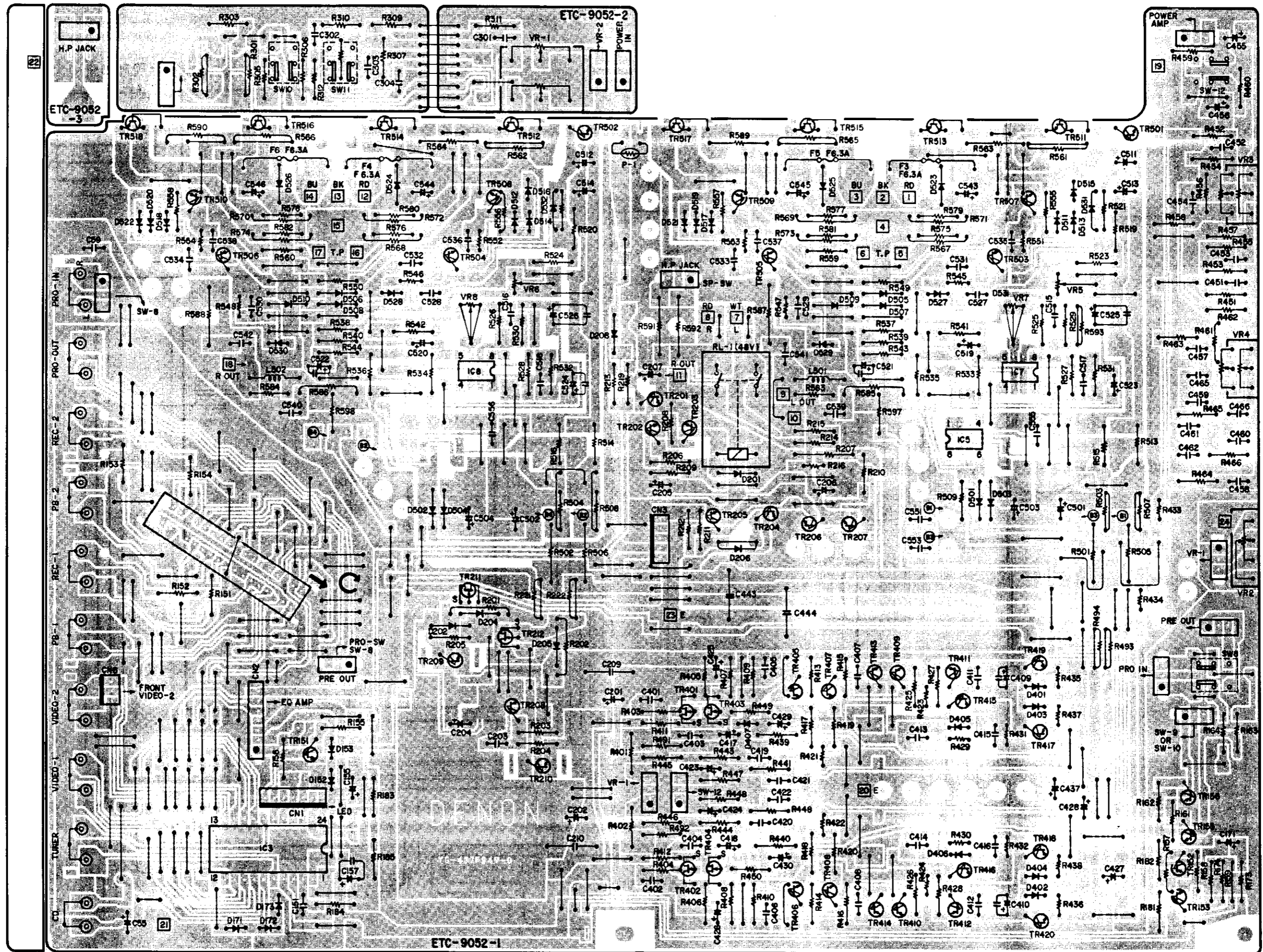

ETC-9052-1

WIRING DIAGRAM
(This figure is specifications of EU & EC Models)

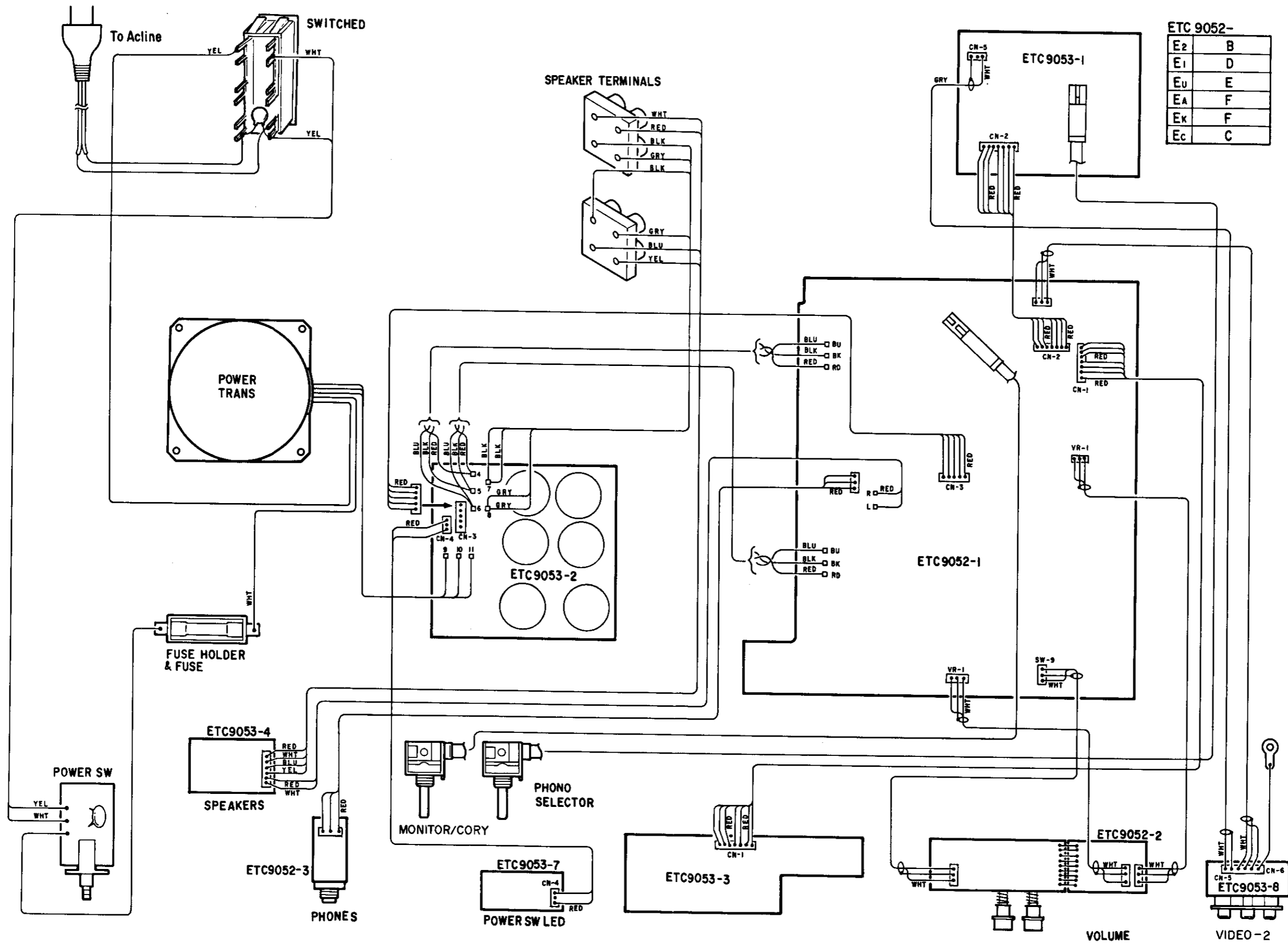

ETC 9052-

E2	B
E1	D
EU	E
EA	F
EK	F
Ec	C

ETC 9053-

E2	B
E1	D
EU	E
EA	F
EK	F
Ec	C

WIRING DIAGRAM
E2 & EK Models (Same as EU version except the following)

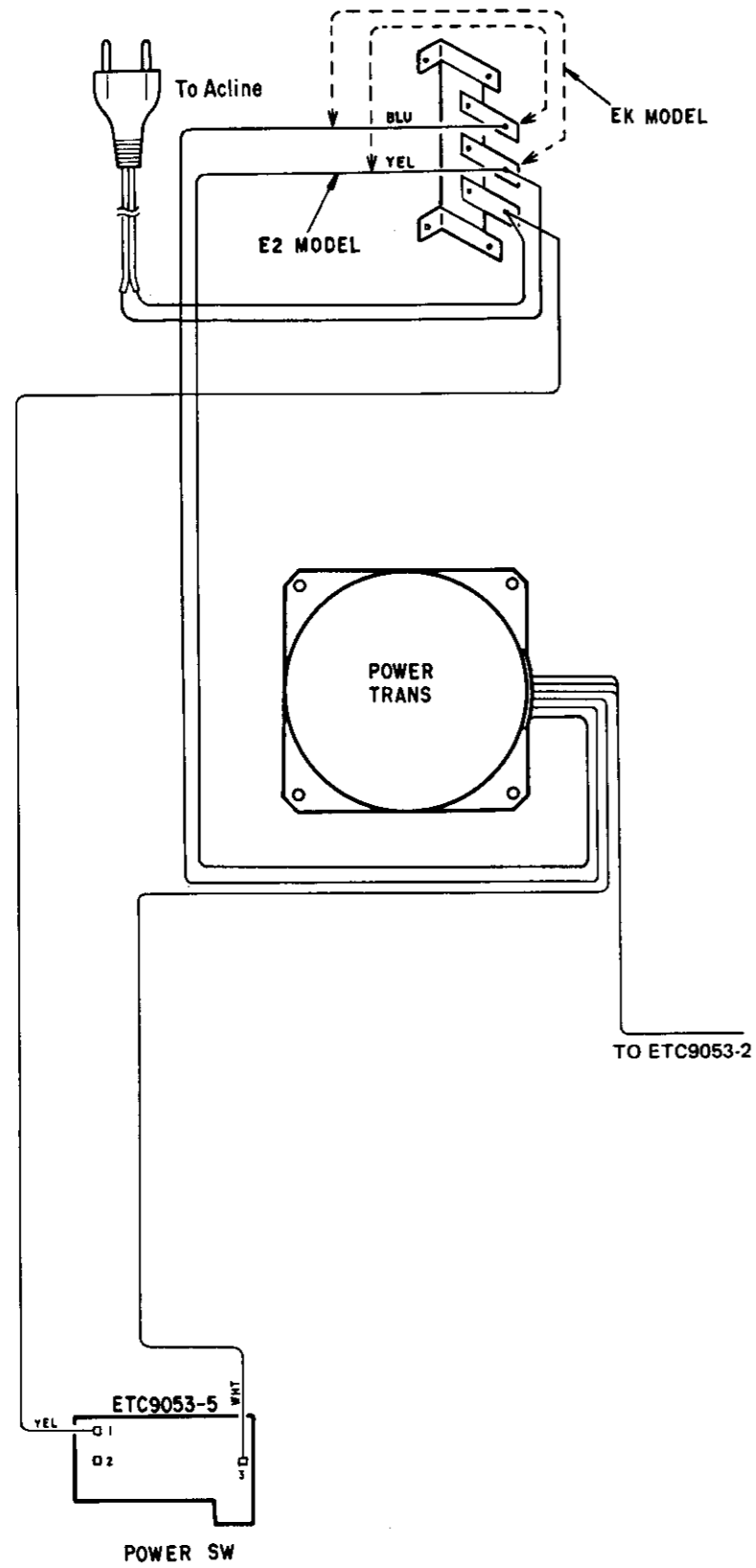

WIRING DIAGRAM
E1 Model (Same as EU version except the following)

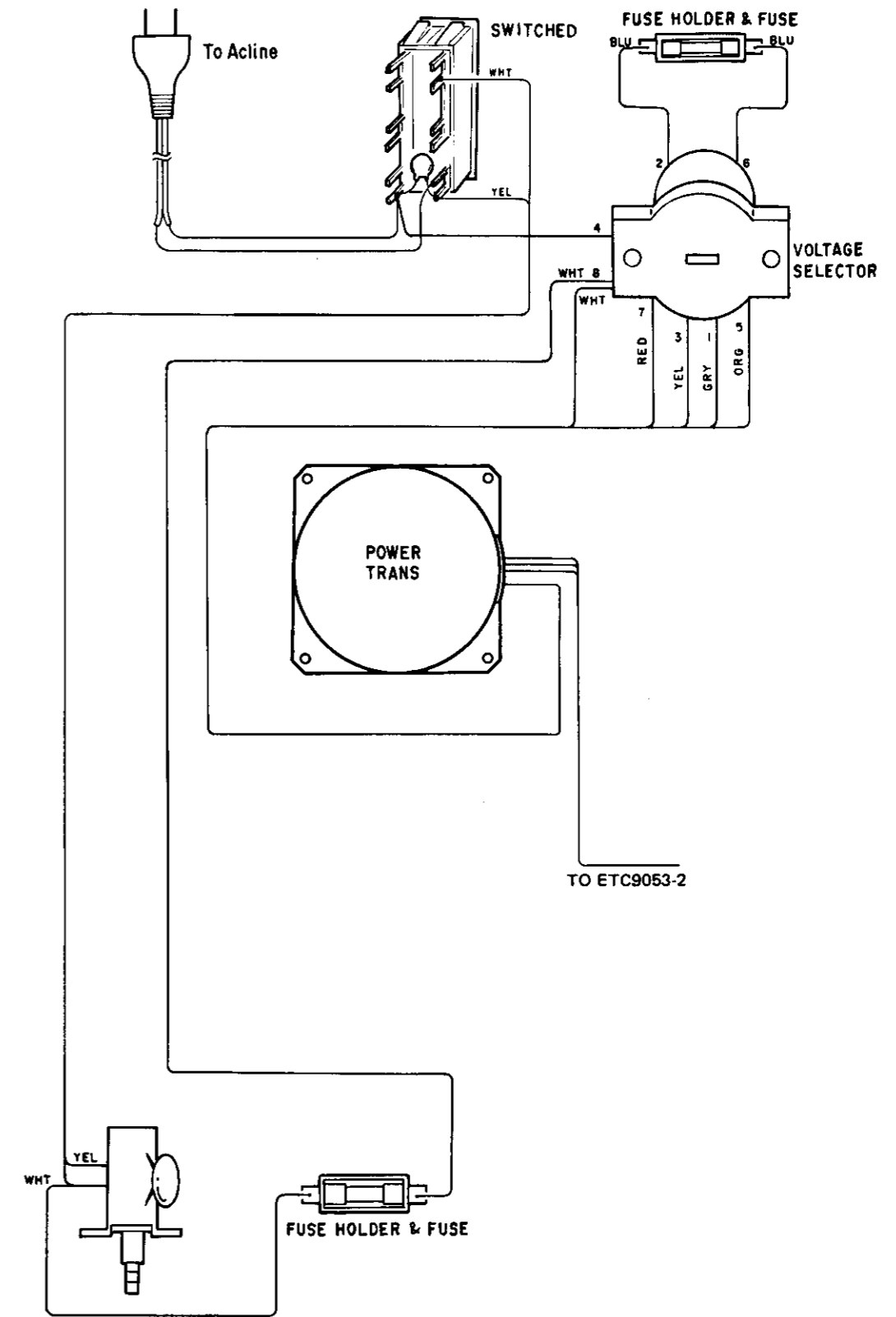

WIRING DIAGRAM
EA Model (Same as EU version except the following)

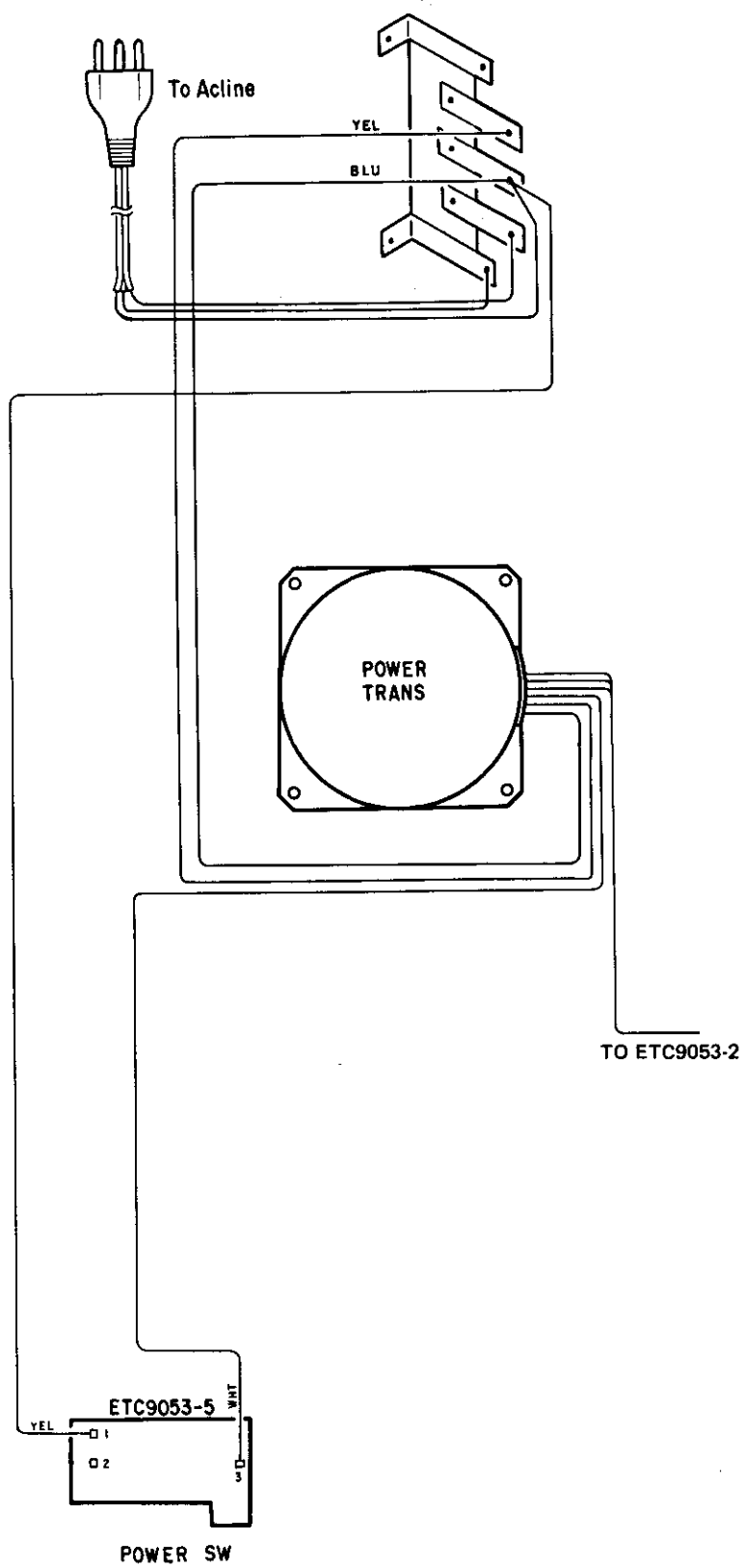

SCHMATIC DIAGRAM

1 2 3 4 5 6

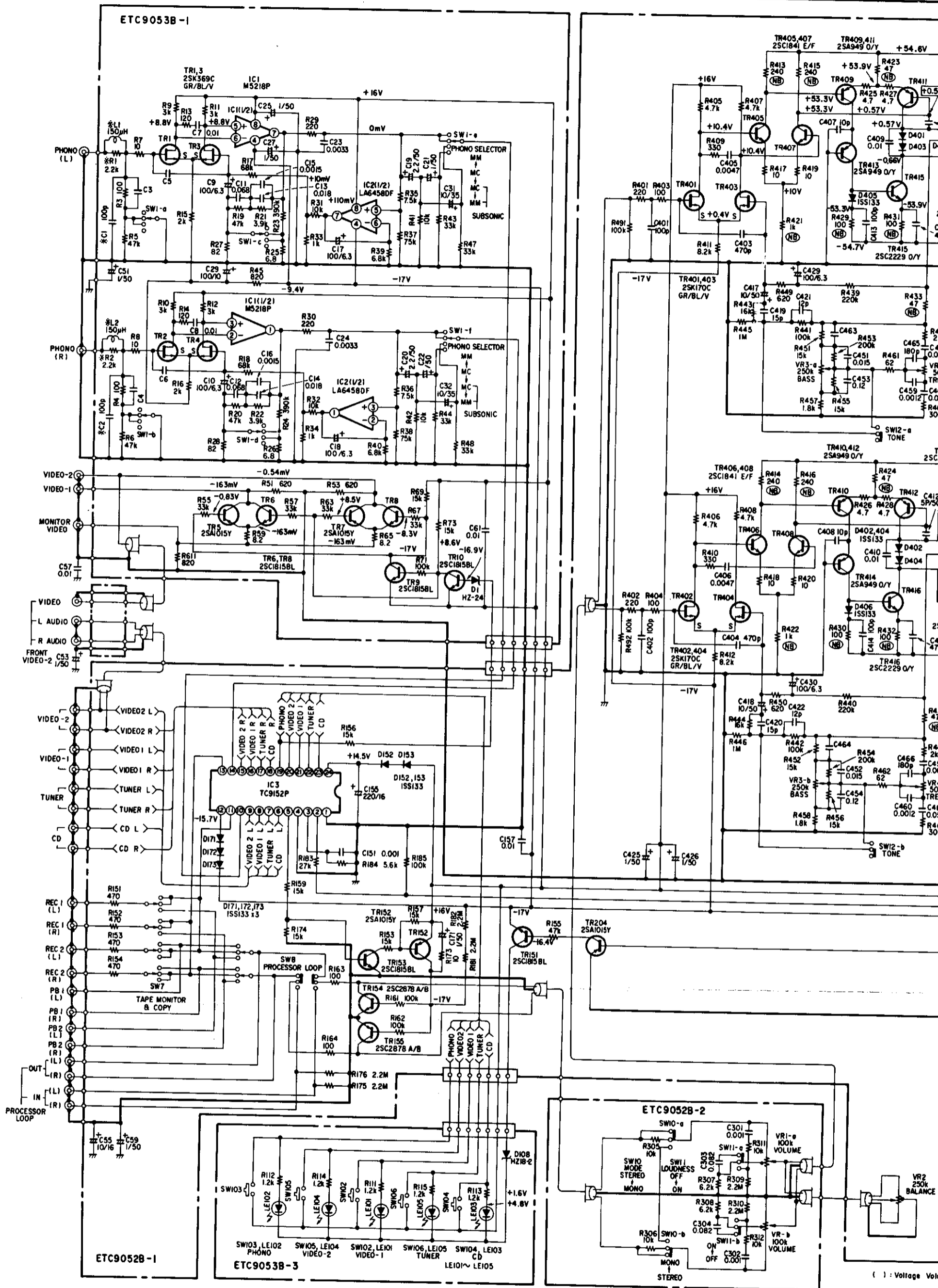

() : Voltage Volt

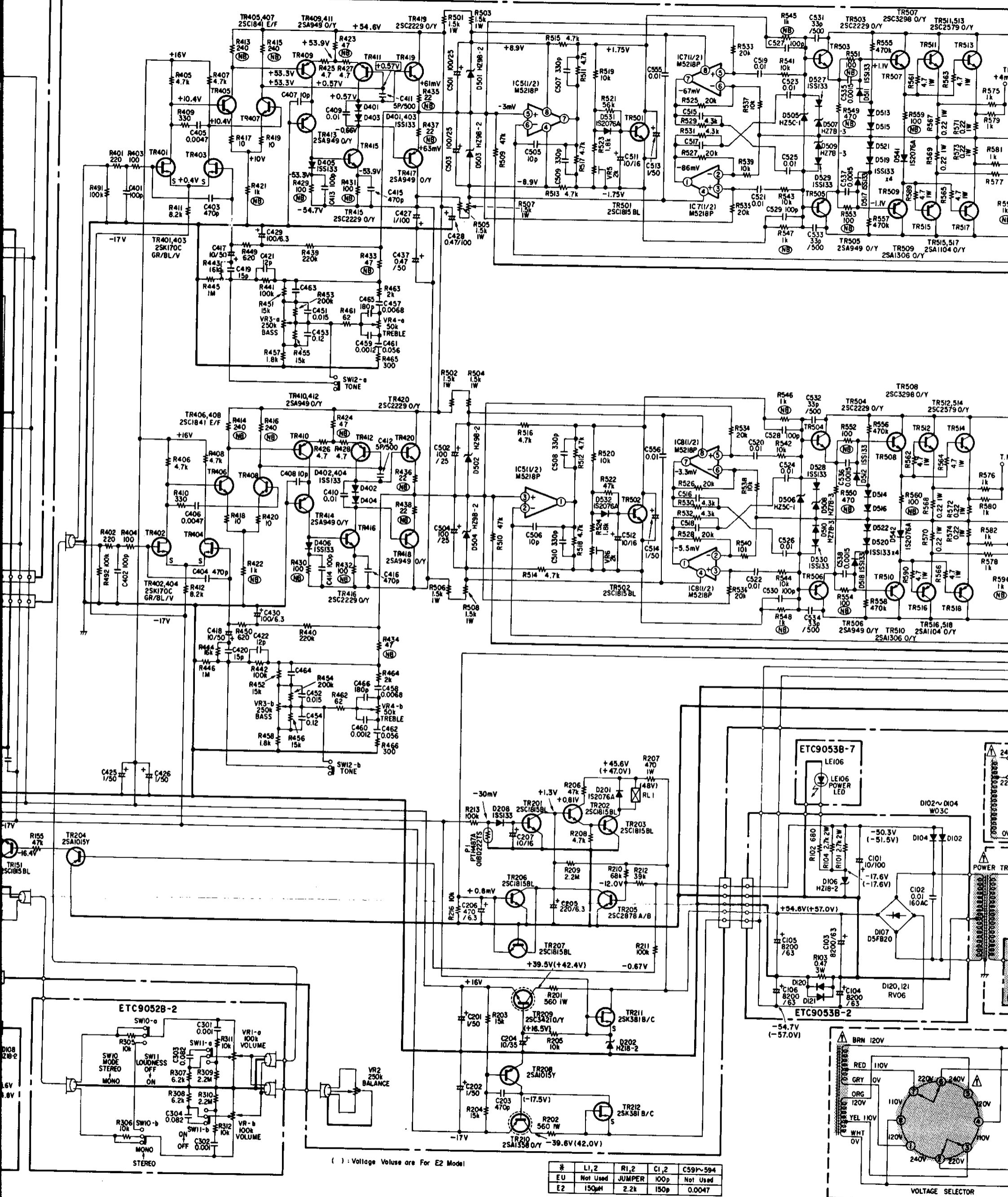

() : Voltage Values are For E2 Model

	LI, 2	RI, 2	CI, 2	C59~594
E1	Not Used	JUMPER	100p	Not Used
E2	150µM	2.2k	150p	0.0047

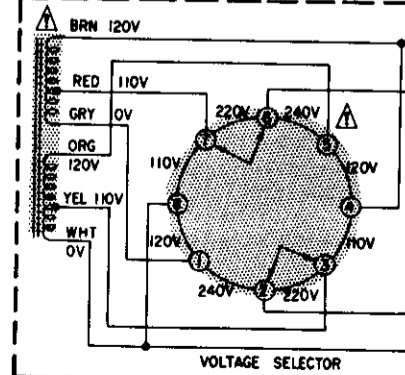

NOTES:
ALL RESISTANCE VALUE
ALL CAPACITANCE VALUE
EVERY VOLTAGES AND
CIRCUIT AND PARTS ARE

Means important safety item, which must be replaced, when necessary, by a part specified or meeting the specification by the manufacturer.

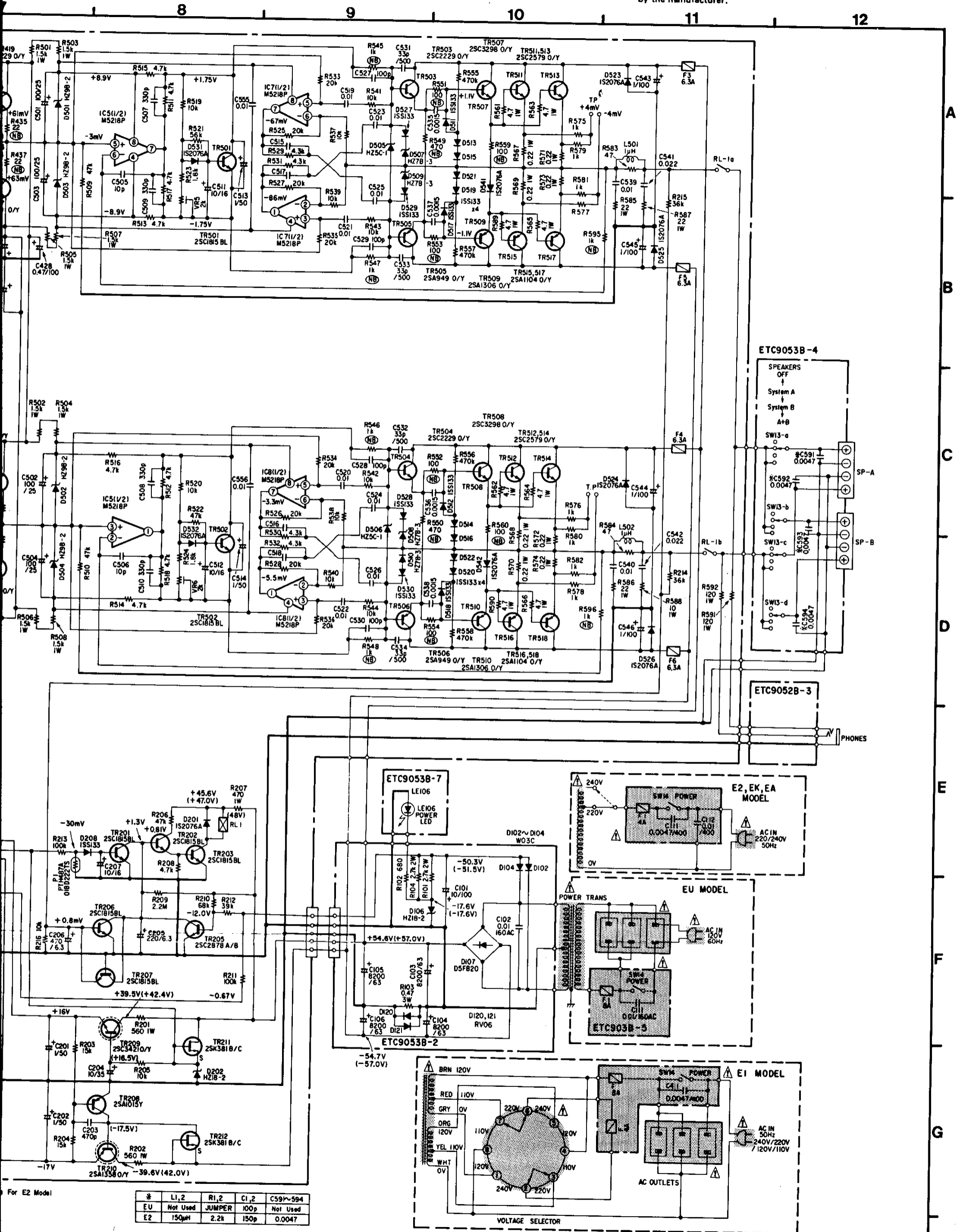

For E2 Model

Model	LI,2	RI,2	CI,2	C59~594
EU	Not Used	JUMPER	100p	Not Used
E2	150µH	2.2k	150p	0.0047

NOTES:
 ALL RESISTANCE VALUES IN OHM, K = 1,000 OHM, M = 1,000,000 OHM.
 ALL CAPACITANCE VALUES IN MICROFARAD, P = MICRO-MICRO FARAD.
 EVERY VOLTAGES AND CURRENTS IS MEASURED AT NO SIGNAL INPUT CONDITION.
 CIRCUIT AND PARTS ARE SUBJECT TO CHANGE WITHOUT PRIOR NOTICE.

EXPLODED VIEW OF CHASSIS AND CABINET
(This figure is specifications of E2.)

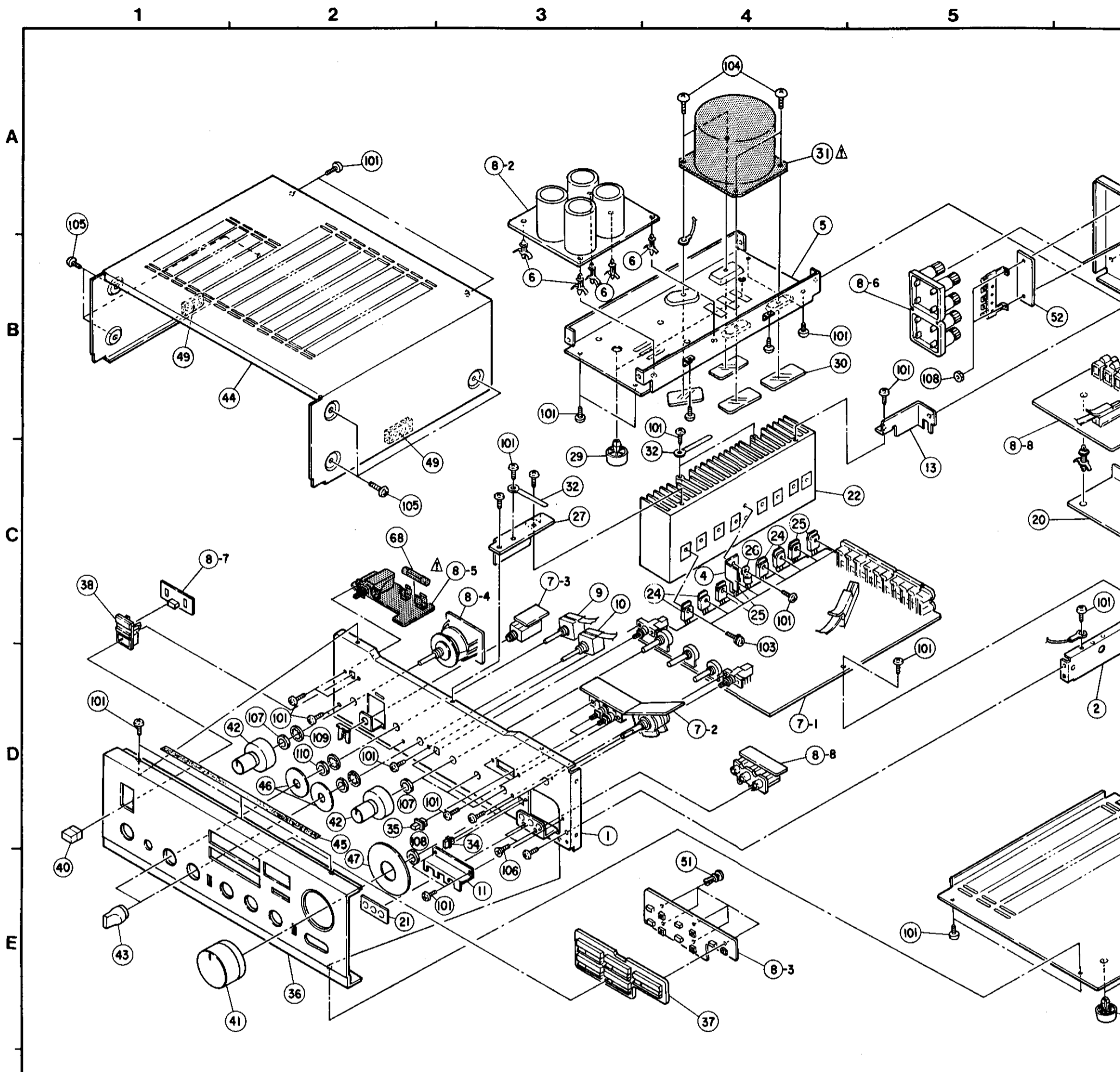

Note 1. See addendum list right for the parts with asterisk (*) on the Ref. No. and the other parts not included in the list.
 2. * marked not included EXPLODED VIEW OF CHASSIS AND CABINET.
 3. This list is prepared based on E2 BLACK VERSION.

EXPLODED VIEW OF PARTS LIST for E2 BLACK VERSION

Ref. No.	Part No.	Part Name & Descriptions	Q'ty	Ref. No.	Part No.	Part Name & Descriptions	Q'ty	Ref. No.	Part No.	Part Name & Descriptions	Q'ty				
1	4119019302	FRONT CHASSIS	1	27	4129039107	RADIATOR BRACKET	1	SCREWS, NUTS							
2	4119020207	SIDE CHASSIS	1	28	1059044100	BOTTOM COVER	1					101	4737002034	TAPPING SCREW (S) BLACK 3x6	44
3	4129038001	P.W.B BRACKET	1	29	1049003009	FOOT	4					102	4737500044	TAPPING SCREW (P) BLACK 3x8	11
4	4129044008	BRACKET	1	30	4149017002	SAFETY PLATE	4	103	4700012022	CROSS PAN SCREW WITH SW, W 3x12	8				
5	4119021109	TRANS CHASSIS	1	31	2339641005	POWER TRANS	1	104	4737004016	TAPPING SCREW (S) 4x6	4				
6	4150228000	P.C.B HOLDER	7	*32	4450048016	CORD HOLDER (L50)	3	*105	4737007000	TAPPING SCREW (S) BLACK 4x8	6				
7	ETC9052B	INPUT & POWER UNIT	1s	*33	4450033005	WIER CLAMP BAND	10	106	4737512003	TAPPING SCREW (P) BLACK 3x8	2				
*8	ETC9053B	EQ & PS UNIT	1	**34	1139071006	PUSH KNOB (T)	2	107	4737006014	TAPPING SCREW (S) WITH WASHER 3x8	2				
9	2123614009	ROTARY REMOTE SW (T. MONI)	1	**35	1139072005	PUSH KNOB (L)	2	108	4756006008	NUT M3	2				
10	2123614012	ROTARY REMOTE SW (PHONO)	1	**36	1449026220	FRONT PANEL ASS'Y	1	PACKING & ACCESSORIES (not included EXPLODED VIEW)							
11	-	-	-	**37	1139073224	PUSH KNOB (F) ASS'Y	1					201	5049102003	STYLEN PAPER	1
*12	1059052105	BACK PANEL	1	**38	1469044101	KNOB GUIDE (P) ASS'Y	1					202	5059102006	POLY COVER	1
13	4129040002	BRACKET	1	39	-	-	1	203	5039123102	CUSHION	2				
14	2050071016	TERMINAL ASS'Y	1	**40	1139070104	PUSH KNOB (P)	1	*204	5019122039	CARTON CASE	1				
15	4770018001	WASHER (P-87)	1	**41	1129012004	VR KNOB ASS'Y	1	205	5119170004	INST. MANUAL	1				
*16	2082002031	AC CORD	1	**42	1129013207	KNOB ASS'Y	4	*206	5139111014	COLOR LABEL (BLACK)	2				
*17	4450020005	CORD BUSH (4K-4)	1	**43	1129014109	KNOB ASS'Y	2	207	5138295009	CONTROL CARD	1				
18	-	-	-	**44	1029013310	TOP COVER	1								
*19	2638010007	CERAMIC CAPACITOR (0.01μF 400V AC)	1	45	1229006017	SPACER	1								
20	2129041001	P.W.B SUPPORT	1	46	1229007029	BLIND RING	2								
21	1469045100	BLIND SHEET	1	47	1229007032	BLIND RING	1								
22	4179012116	POWER RADIATOR	1	48	1229006033	SPACER	3								
23	4150234007	INSULATING SHEET	8	49	-	-	-								
24	2730232023	TRANSISTOR 2SC2579(O)/(Y) (TR511-514)	4	50	-	-	-								
25	2710130022	TRANSISTOR 2SA1104(O)/(Y) (TR515-518)	4	51	4770210016	PUSH RIVET	5								
26	2760289004	POSITIVE THERMISTOR PTH487A01BD222TS	1	52	4150088004	INSULATING SHEET	1								
				*53	2050089008	7P W. TERMINAL	1								
				54	1220114005	SPACER	2								

⚠ Means important safety item, which must be replaced, when necessary, by a part specified or meeting the specification by the manufacturer.

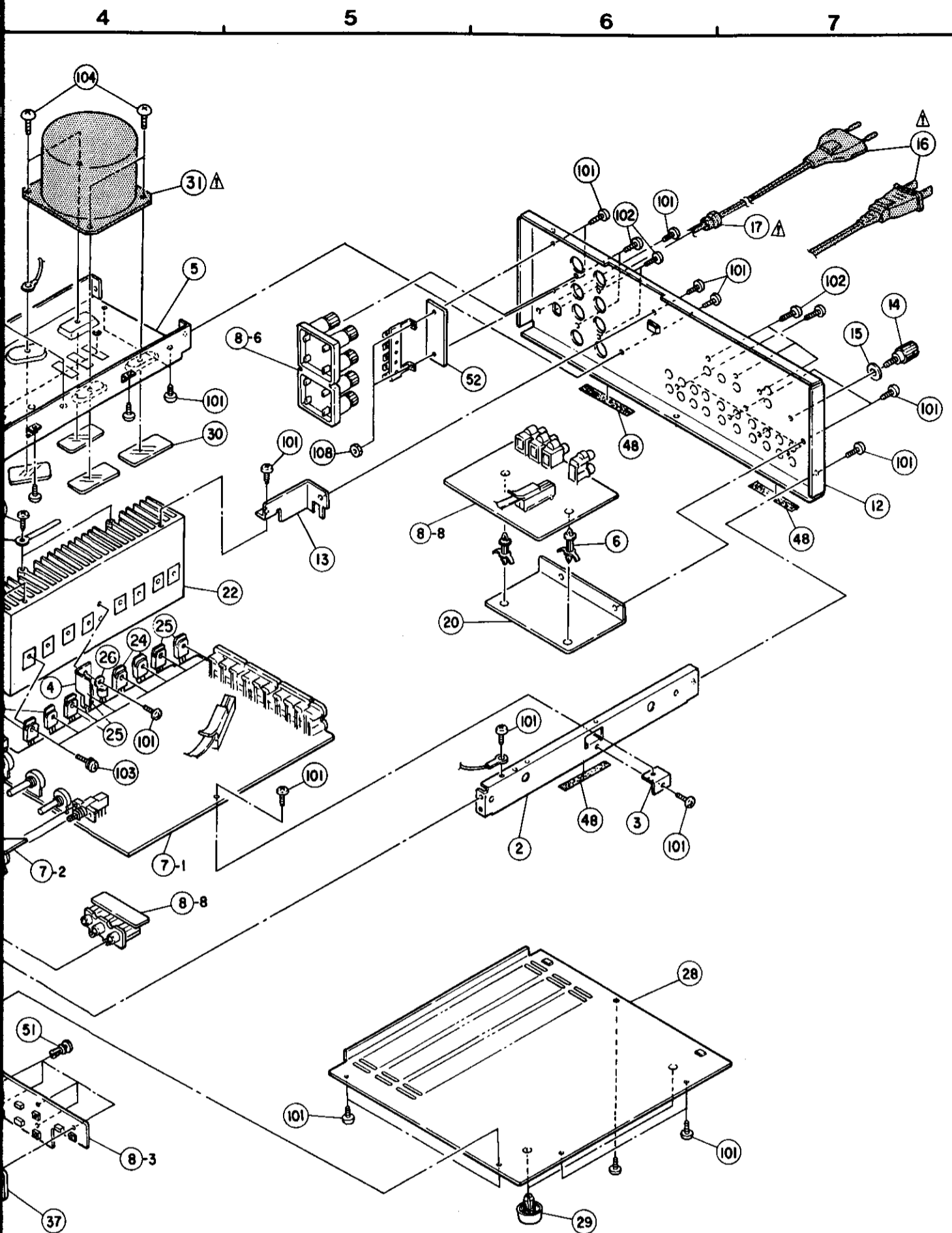

WARNING:

- Component parts**
Parts marked with ⚠ and/or shading in this series are important safety items. Replace only the specified parts for replacement.
- Leakage current**
Before returning the appliance to customer, test for leakage current (allowing an error of not more than 5%) leakage current to ground. Reverse the power plug polarity and test again. Any current measured MUST NOT EXCEED 0.5 mA.



CAUTION: TO PREVENT ELECTRICAL SHOCK, DO NOT TOUCH USER SERVICE PARTS WITHOUT DISCONNECTING TO QUALIFIED PERSONNEL.



The lightning flash symbol is intended to alert the user of the presence of "high voltage" within the appliance to constitute a risk of electric shock.



The exclamation mark symbol is intended to alert the user of the presence of important instructions in the user manual.

WARNING: TO PREVENT ELECTRICAL SHOCK, DO NOT EXPOSE USER SERVICE PARTS TO USER SERVICE PERSONNEL.

ADDENDUM LIST

Ref. No.	Part Name & Descriptions	Q'ty
7	INPUT & POWER UNIT	ET
⚠ 8	EQ. & P.S. UNIT	ET
12	BACK PANEL	10
⚠ 16	AC CORD	20
⚠ 17	CORD BUSH	44
⚠ 31	POWER TRANS.	23
36	FRONT PANEL ASS'Y	14
37	PUSH KNOB (F) ASS'Y	11
52	INSULATING SHEET	
53	7P W. TERMINAL	
61	VOLTAGE LABEL	
62	BLIND SHEET	
63	EARTH LABEL	
64	NOTICE SHEET	
65	NOTICE SHEET	
⚠ 66	AC OUTLET (POLARIZED)	20
⚠ 67	FUSE HOLDER	20
⚠ 68	FUSE (8A)	20
⚠ 69	VOLTAGE SEL SW.	21
70	CAUTION SHEET	
71	IMPORTANT LABEL	
72	FUSE LABEL	
73	LA APPROVAL MARK	
74	DANGEROUS MARK	
75	CSA LABEL	
⚠ 76	POWER SWITCH	21
⚠ 77	CAPACITOR (100µF/400V (AC))	25
101	TAPPING SCREW (S) 3x6 (BLACK)	47
107	TAPPING SCREW (S) WITH WASHER 3x8	
108	NUT M3	
111	φ3 TOOTH WASHER	
112	3T LUG	
113	φ4 TOOTH WASHER	
114	TAPPING SCREW 4x16 (BLACK)	47
204	CARTON CASE	50
207	CONTROL CARD	
211	CAUTION PAPER	
212	WARRANTY IN ENVELOPE	
213	SAFETY INSTRUCTION	51
214	COLOR LABEL (BLACK)	51

Parts with asterisk (*) on the Ref. No. and the other parts not included in the list.
EXPLODED VIEW OF CHASSIS AND CABINET.
2 BLACK VERSION.

GOLD VERSION PARTS LIST (Same as BLACK VERSION except the followings.)

Q'ty	Ref. No.	Part No.	Part Name & Descriptions	Q'ty	Ref. No.	Part No.	Part Name & Descriptions	Q'ty
1			SCREWS, NUTS		34	1139071019	PUSH KNOB (T)	2
1					35	1139072021	PUSH KNOB (L)	2
4	101	4737002034	TAPPING SCREW (S) BLACK 3x6	44	36	1449033006	FRONT PANEL ASS'Y	1
4	102	4737500044	TAPPING SCREW (P) BLACK 3x8	11	37	1139073211	PUSH KNOB (F) ASS'Y	1
3	103	4700012022	CROSS PAN SCREW WITH SW, W 3x12	8	38	1469044114	KNOB GUIDE (P) ASS'Y	1
10	104	4737004016	TAPPING SCREW (S) 4x6	4	40	1139070117	PUSH KNOB (P)	1
2	**105	4737007000	TAPPING SCREW (S) BLACK 4x8	6	41	1139012017	VR KNOB ASS'Y	1
2	106	4737512003	TAPPING SCREW (P) BLACK 3x8	2	42	1129013210	KNOB ASS'Y	4
1	107	4737006014	TAPPING SCREW (S) WITH WASHER 3x8	2	43	1129014112	KNOB ASS'Y	2
1	108	4756006008	NUT M3	2	44	1029013336	TOP COVER	1
1			PACKING & ACCESSORIES (not included EXPLODED VIEW)		105	4737014006	TAPPING SCREW(S) 4x8	6
1	201	5049102003	STYLEN PAPER	1	204	5019122084	CARTON CASE	1
4	202	5059102006	POLY COVER	1	206	5139111001	COLOR LABEL (GOLD)	2
1	203	5039123102	CUSHION	2				
1	**204	5019122039	CARTON CASE	1				
2	205	5119170004	INST. MANUAL	1				
1	**206	5139111014	COLOR LABEL (BLACK)	2				
3	207	5138295009	CONTROL CARD	1				

Important safety item, which must be replaced,
by a part specified or meeting the specification
number.

DENON

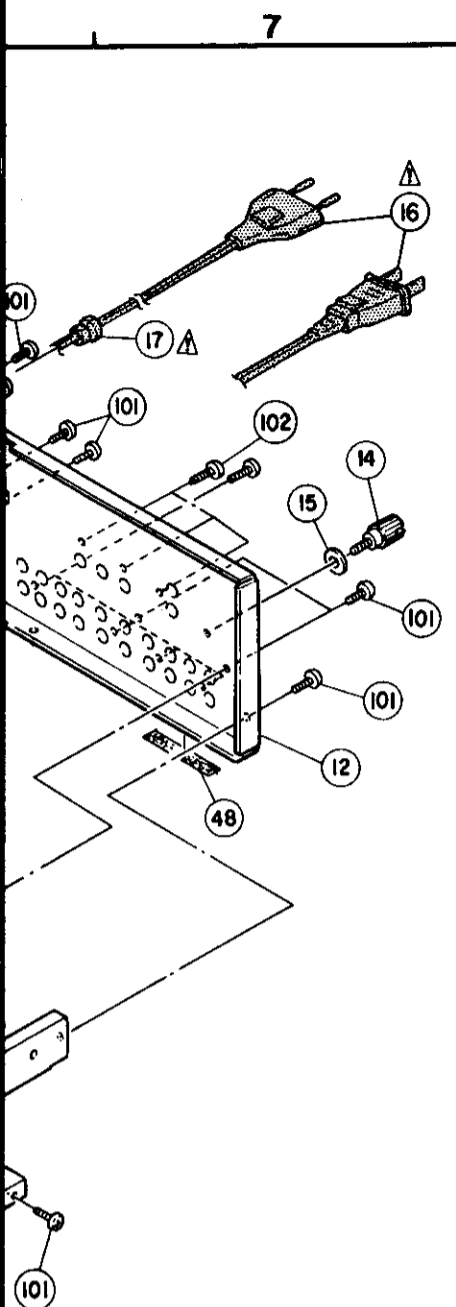

WARNING:

1. Component parts

Parts marked with  and/or shading in this service manual have special characteristics important to safety. Be sure to use the specified parts for replacement.

2. Leakage current

Before returning the appliance to customer, test the leakage current when the power plug is connected. Use a calibrated (with an error of not more than 5%) leakage current tester and measure the leakage current from any exposed metal to the earth ground. Reverse the power plug polarity and test the above again.

Any current measured MUST NOT EXCEED 0.5 milliamps. Corrective measure must be taken if it exceeds the limit.



CAUTION
RISK OF ELECTRIC SHOCK
DO NOT OPEN



CAUTION: TO REDUCE THE RISK OF ELECTRIC SHOCK, DO NOT REMOVE COVER (OR BACK). NO USER SERVICEABLE PARTS INSIDE. REFER SERVICING TO QUALIFIED SERVICE PERSONNEL.













The lightning flash with arrowhead symbol within an equilateral triangle is intended to alert the user of the presence of uninsulated "dangerous voltage" within the product's enclosure that may be of sufficient magnitude to constitute a risk of electric shock to persons.



The exclamation point within an equilateral triangle is intended to alert the user of the presence of important operating and maintenance (servicing) instructions in the literature accompanying the appliance.

WARNING: TO PREVENT FIRE OR SHOCK HAZARD, DO NOT EXPOSE THIS APPLIANCE TO RAIN OR MOISTURE.

ADDENDUM LIST

Ref. No.	Part Name & Descriptions	Part No.				
		E1/EP1 for Asia	EU for U.S.A.	EA for Australia	EK for U.K.	EC for Canada
7	INPUT & POWER UNIT	ETC9052D	ETC9052E	ETC9052F	ETC9052F	ETC9052L
	EQ. & P.S. UNIT	ETC9053D	ETC9053E	ETC9053F	ETC9053F	ETC9053L
12	BACK PANEL	1059055005	1059042115	1059052105	1059052105	1059042115
	AC CORD	2062031026	2062039004	2062012018	2062024006	2062039004
	CORD BUSH	4450028007	4450020006	MD-2982H	4450020006	4450020006
	POWER TRANS.	2339548000	2339539004	2339541006	2339541006	—
36	FRONT PANEL ASS'Y	1449026110	1449026110	1449026123	1449026123	1449026110
37	PUSH KNOB (F) ASS'Y	1139073101	1139073101	1139073224	1139073224	1139073101
52	INSULATING SHEET	—	—	4150088004	4150088004	—
53	7P W. TERMINAL	—	—	2050089008	2050089008	—
61	VOLTAGE LABEL	—	—	5130362008	5130362008	—
62	BLIND SHEET	—	—	5130348006	—	—
63	EARTH LABEL	—	—	5130140000	—	—
64	NOTICE SHEET	—	—	5130209006	—	—
65	NOTICE SHEET	—	—	5130210008	—	—
	AC OUTLET (POLARIZED)	2033926007	2033926007	—	—	2033926007
	FUSE HOLDER	2020013101(2)	2020013101(2)	—	—	2020013101
	FUSE (8A)	2061048014	2061048014	—	—	2061048014
	VOLTAGE SEL SW	2120186006	—	—	—	—
70	CAUTION SHEET	—	—	—	5130364006	—
71	IMPORTANT LABEL	—	—	—	5139133005	—
72	FUSE LABEL	—	5130607019	—	—	—
73	LA APPROVAL MARK	—	5138300004	—	—	—
74	DANGEROUS MARK	—	5138266009	—	—	—
75	CSA LABEL	—	(2)	—	—	5138311006
	POWER SWITCH	2129534002	2129534002	—	—	2129534002
	CAPACITOR, 0.1μF/400V (AC)	2538003014 (0.047)	2538010007 (0.01)	—	—	2538010007 (0.01)
101	TAPPING SCREW (S) 3x6 (BLACK)	4737002034 (38)	4737002034 (36)	4737002034 (37)	4737002034 (36)	4737002034 (36)
107	TAPPING SCREW (S) WITH WASHER 3x8	—	—	4737006014 (2)	4737006014 (2)	—
108	NUT M3	—	—	4756006008 (2)	4756006008 (2)	—
111	φ3 TOOTH WASHER	—	—	4753001051 (1)	—	—
112	3T LUG	—	—	2050003107	—	—
113	φ4 TOOTH WASHER	—	—	4753100004 (6)	—	—
114	TAPPING SCREW 4x16 (BLACK)	4734453039	—	—	—	—
204	CARTON CASE	5019122039	5019116032	5019122039	5019122039	5019116032
207	CONTROL CARD	—	—	—	—	—
211	CAUTION PAPER	—	—	5130211007	—	—
212	WARRANTY IN ENVELOPE	—	5150349108	—	—	—
213	SAFETY INSTRUCTION	5158052206	—	—	—	—
214	COLOR LABEL (BLACK)	5139111014 (2)	5111041102 (2)	5139111014 (2)	5139111014 (2)	513911

REVISION PARTS LIST (LACK VERSION except the followings.)

Part No.	Part Name & Descriptions	Q'ty
9071019	PUSH KNOB (T)	2
9072021	PUSH KNOB (L)	2
9033006	FRONT PANEL ASS'Y	1
9073211	PUSH KNOB (F) ASS'Y	1
9044114	KNOB GUIDE (P) ASS'Y	1
9070117	PUSH KNOB (P)	1
9012017	VR KNOB ASS'Y	1
9013210	KNOB ASS'Y	4
9014112	KNOB ASS'Y	2
9013336	TOP COVER	1
87014006	TAPPING SCREW(S) 4x8	6
9122084	CARTON CASE	1
9111001	COLOR LABEL (GOLD)	2

NIPPON COLUMBIA CO., LTD.
No. 14-14, 4-CHOME AKASAKA,
MINATO-KU, TOKYO 107 JAPAN

TEL: 03-584-8111
TLX: JAPANOLA J22591
CABLE: NIPPONCOLUMBIA TOKYO

Printed in Japan