

DENON

Hi-Fi Integrated Amplifier

SERVICE MANUAL MODEL PRA-1100

FOR EUROPEAN, U.K.
AND OTHER MODELS

INTEGRATED AMPLIFIER

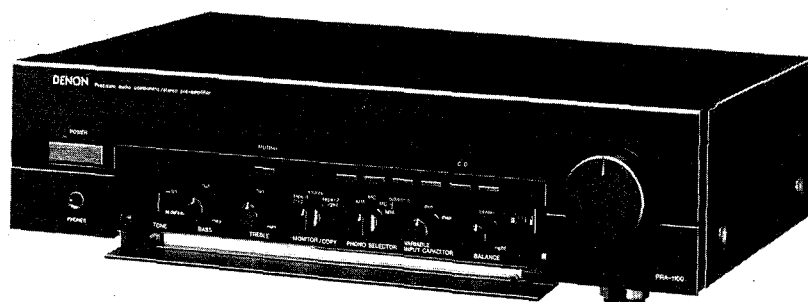

TABLE OF CONTENTS

SPECIFICATIONS	2
NAMES AND FUNCTIONS OF PARTS	3
CONNECTIONS	4
BLOCK DIAGRAM	4
METHOD OF ADJUSTMENTS	5
REMOVAL OF EACH SECTION	6
TROUBLESHOOTING	7
SEMICONDUCTORS	7
PRINTED WIRING BOARD PATTERNS AND PARTS LIST	
ETC9072B MAIN UNIT	8,9
WIRING DIAGRAM	10
SCHEMATIC DIAGRAM	11
EXPLODED VIEW OF CHASSIS AND CABINET & PARTS LIST	12

NIPPON COLUMBIA CO., LTD.

SPECIFICATIONS

EQUALIZER AMPLIFIER (PHONO IN ~ REC OUT)

Input sensitivity			
impedance:	Phono-	MC:	0.2 mV/100 ohms
	Phono-	MM:	2.5 mV/47 k ohms
Variable input capacitor:	Phono		200 pF~ 600 pF
Max. input level:	Phono-	MC:	13 mV/1 kHz
	Phono-	MM:	160 mV/1 kHz
Max. Output/rated output:			10 V/150 mV
Total harmonic distortion:			Less than 0.001% (1 kHz, 7 V output)
RIAA deviation:	Phono-	MC:	20 Hz ~ 100 kHz ±0.3 dB
	Phono-	MM:	20 Hz ~ 20 kHz ±0.2 dB
S/N ratio:	Phono-	MC:	79 dB (A-weighting) at 0.5 mV input
	Phono-	MM:	96 dB (A-weighting) at 5 mV input
Gain:	Phono-	MC:	57.5 dB/1 kHz
	Phono-	MM:	35.6 dB/1 kHz
Phono subsonic filter:			16 Hz, 12 dB/OCT

HIGH-LEVEL AMPLIFIER (AUX IN ~ PRE OUT)

Input sensitivity/impedance:	CD, TUNER, AUX 1, 2, TAPE 1, 2: 150 mV/47 k ohms CD DIRECT: 1 V/10 k ohms
-------------------------------------	---

Max. output/rated output:	10 V/1 V
Total harmonic distortion:	Less than 0.003% (20 Hz ~ 20 kHz, 5 V output)
Frequency response:	1 Hz ~ 300 kHz + 0.2 dB - 3 dB 10 Hz ~ 100 kHz ± 0.2 dB
S/N ratio:	105 dB (A-weighting)
Tone control:	Treble 10 kHz ±8 dB Bass 100 Hz ±8 dB
Muting:	PRE out off and Headphones circuit muting (indication by LED)
Gain:	16.5 dB
Output impedance:	10 ohms

GENERAL

Power supply:	AC 220 V/50 Hz (for Europe) AC 240 V/50 Hz (for UK & Australia)
DC output:	15V x 2 (1mA)
Power consumption:	15 W
Dimensions:	434 mm (17-3/32")W x 119 mm (4-11/16")H x 302 mm (11-57/64")D (Including control knobs and feet)
Weight (Net weight):	5.0 kg (11 lbs 1 oz)

Design and specifications are subject to change without prior notice.

NOTE: The following codes correspond to the appropriate models.
E2 for Europe, EK for U.K. EA for Australia.
This Service manual is prepared based on E2 Black Bersion.

All values in this specifications are measured at minimum volume level of headphones. (except the ones in headphone circuit.)

NAMES AND FUNCTIONS OF PARTS

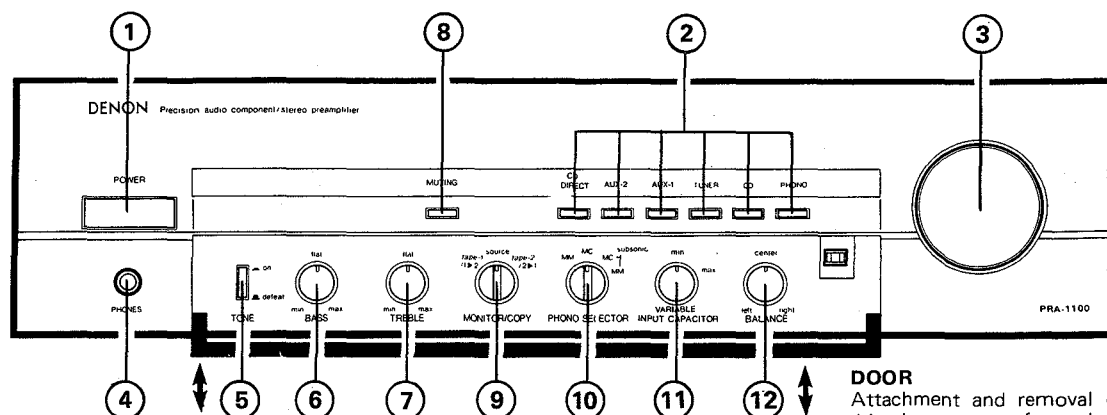

DOOR
Attachment and removal of this door are performed in the directions indicated by the arrows.

- ① POWER (Power switch)
- ② INPUT SELECTOR (Input select button)
- ③ VOLUME (Volume control)
- ④ PHONES (Headphones jack)
- ⑤ TONE (Tone switch)
- ⑥ BASS (Bass control)
- ⑦ TREBLE (Treble control)
- ⑧ MUTING (Muting switch)
- ⑨ MONITOR COPY (Tape monitor/copy switch)
- ⑩ PHONO SELECTOR (Cartridge selection/Subsonic filter switch)
- ⑪ VARIABLE INPUT CAPACITOR
- ⑫ BALANCE (Balance control)

● Notes on installing the pre-amplifier

To prevent influence caused by radiation from the power amp or externally induced humming, install the pre-amplifier to one side of the power amp. If such installation is not possible, separate the pre-amplifier 15 cm or more from the power amp or external noise source.

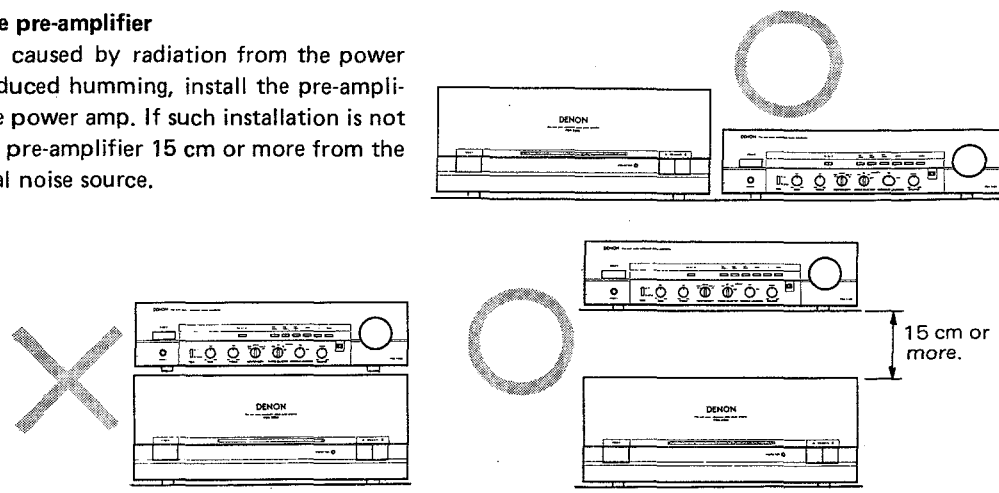

Fig. 2

CONNECTIONS

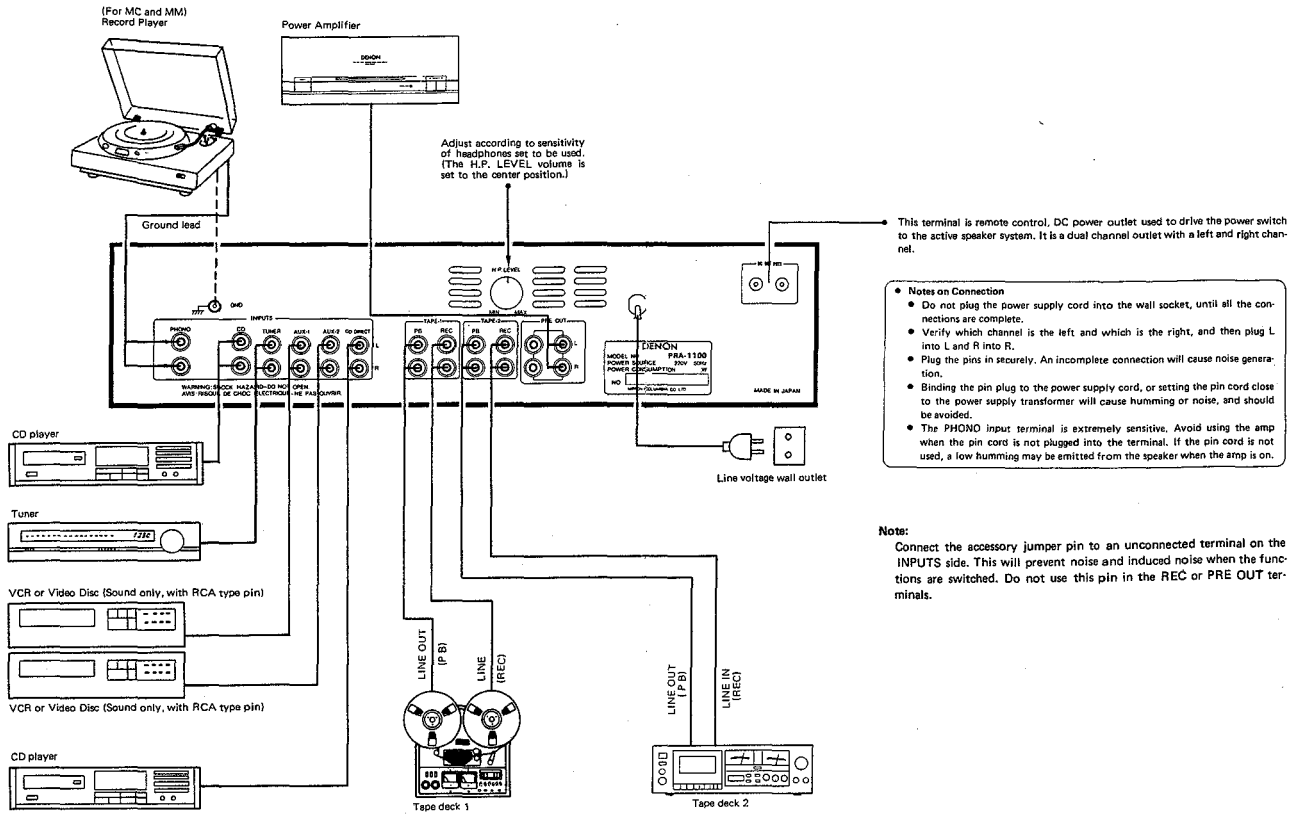

Fig. 3

BLOCK DIAGRAM

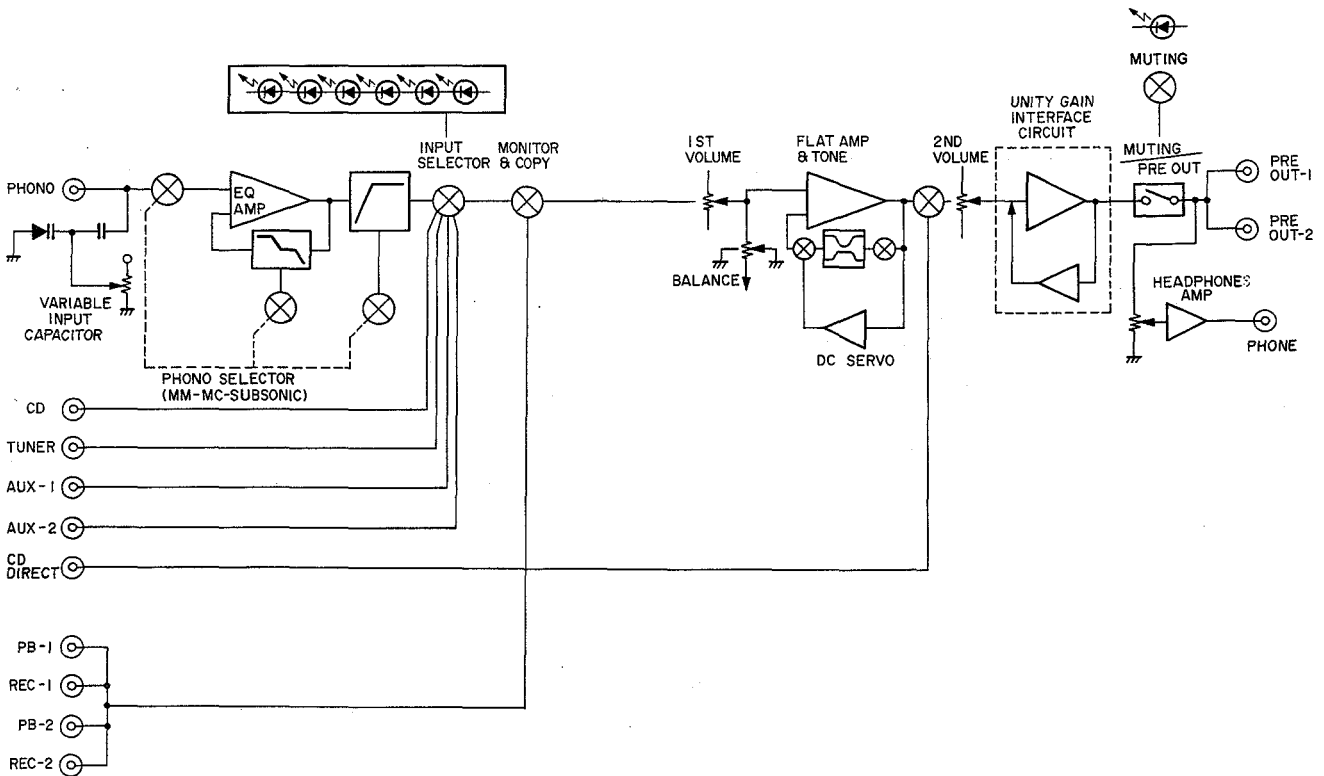

Fig. 4

METHOD OF ADJUSTMENTS

When marking adjustments, be sure the power supply is at the rated voltage and the room air is in normal condition with respect to temperature and humidity.

IDLE CURRENT ADJUSTMENT (Fig. 5)

1. Keep the unit away from direct wind blown by an air-conditioner and an electric fan, and keep the unit under normal conditions. Adjust the range of ambient temperature to $15 \sim 30^{\circ}\text{C}$.
2. Set the following switches as follows:
 - POWER (power switch) to off
 - VOLUME (VOLUME CONTROL) to 0 (\curvearrowright)
3. Remove the top cover and connect a DC digital voltmeter to the test points of ETC9072 (VOLUME unit) (between the positive terminal TP and the negative terminal (chassis ground), and between the positive TP and the negative terminal (chassis ground). (Refer to Fig. 3-6)
4. Connect Power cord to AC outlet, and turn Power Switch "on" (\blacksquare). Within 10 seconds turn VR206 (Lch) and VR207 so that the DC voltmeter reads $0 \text{ mV} \pm 3 \text{ mV}$.

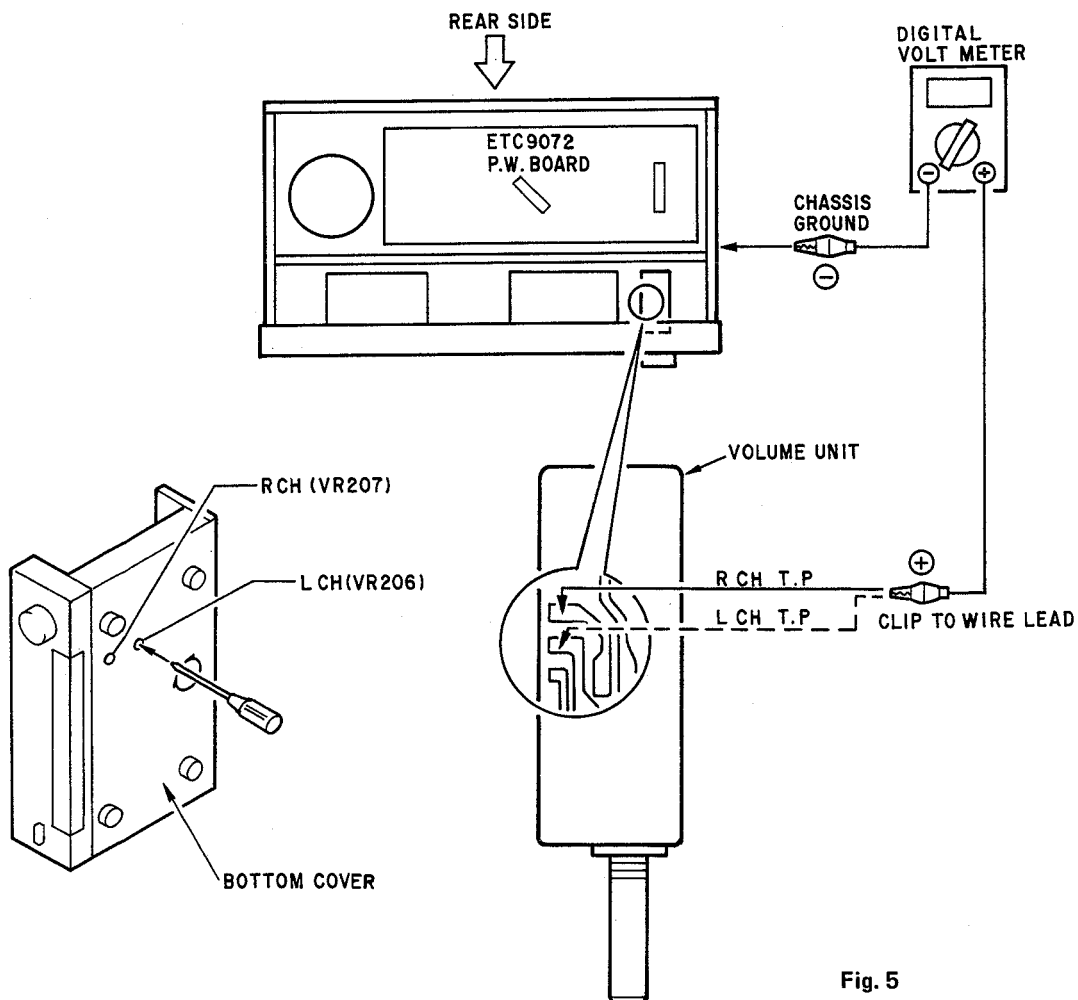

Fig. 5

HEADPHONES SENSITIVITY ADJUSTMENT

The headphones sensitivity of this unit is adjustable to increase a level approximately 20 dB by adding two resistors on the places mentioned below.

Add to printed mark on P.W.B	Adding Part No. & Resistance value		
R405	2412092002	RD14B2E102J	1/4W 1K Ω (J)
R406	2412092002	RD14B2E102J	1/4W 1K Ω (J)

REMOVAL OF EACH SECTION (Reverse the procedure to install the covers.)

1. How to remove the top cover (Fig. 6)

- 1) Remove the six screws holding the top cover in place.
- 2) Pull out the sides of the cover to free it, then lift off the cover.

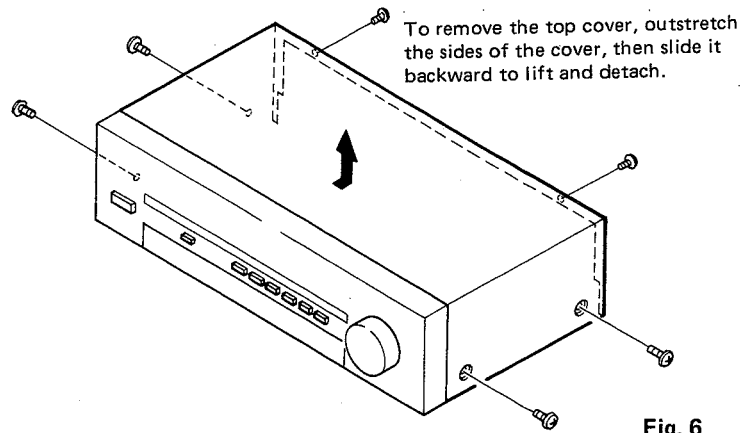

Fig. 6

2. How to remove the back panel (Fig.7)

- 1) Remove the fourteen screws holding the back panel in place.
- 2) Pull the back panel toward you and remove it.

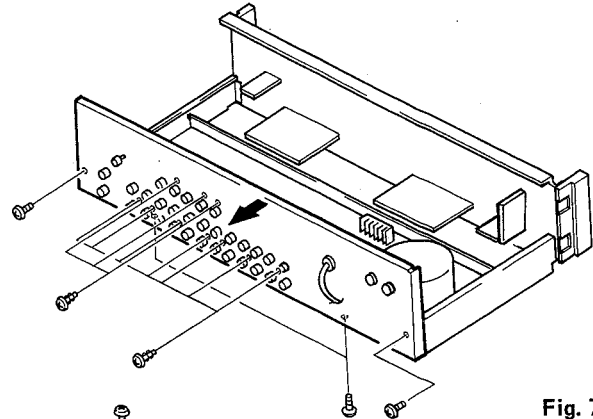
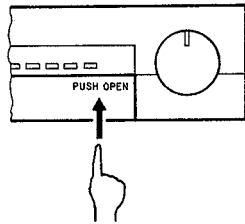

Fig. 7

3. How to remove the front panel (Fig. 8)

- 1) Open the door by pressing "push open" spot on the door.

Note: Be sure to press "push open" spot when opening or closing the door, otherwise the door will be damaged.



- 2) Pull off the six knobs.

Note: Because the knobs are tightly inserted on the shafts, use an appropriate pair of pliers to remove and not to give them damages.

- 3) Remove the five screws holding the front panel in place.

- 4) Pull the front panel toward you and remove it.

- 5) Carefully tear off the safety plate by cutter or the like when removing the P.C.Board. When installing the P.C.Board, adjust the movement of knob to stick the safety plate. (Stick the safety plate by means of pushing the knob and that will not affect neighbor knob.)

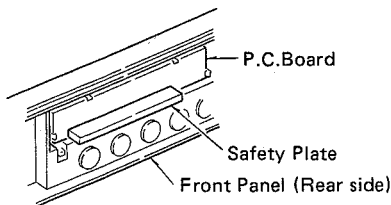

After stuck the plate, check to see that the pushing of knob does not affect other knobs.

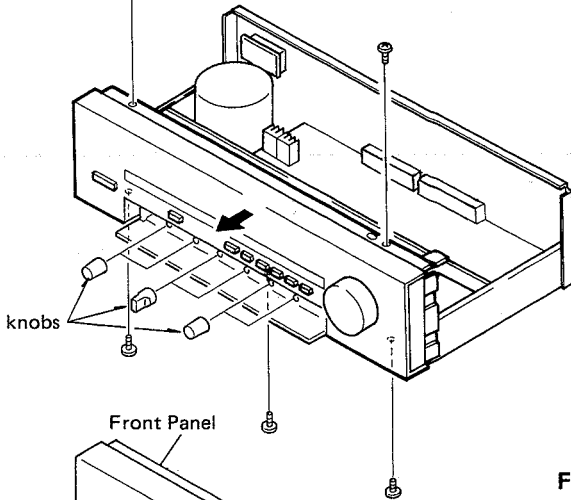

Fig. 8

4. How to remove/Install the door (Fig. 9)

(Door must be opened.)

While pushing the hinges on both sides, remove or install door in the direction arrow shows.

Never remove the washers attached on the hinges.

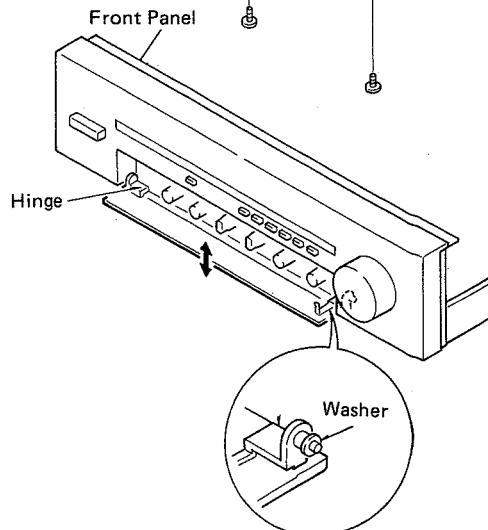

Fig. 9

TROUBLESHOOTING

Prior to anything, be sure whether or not your audio and video system is really in trouble.

1. Check all connections for correctness.
2. See to it that your audio and video system is operated properly according to the instruction manual.
3. Check that the speakers and turntable are working properly.

If your PRA-1100 pre-amplifier does not provide normal performance, check it referring to the following troubleshooting chart. If the unit still malfunctions after this check, contact your local DENON dealer.

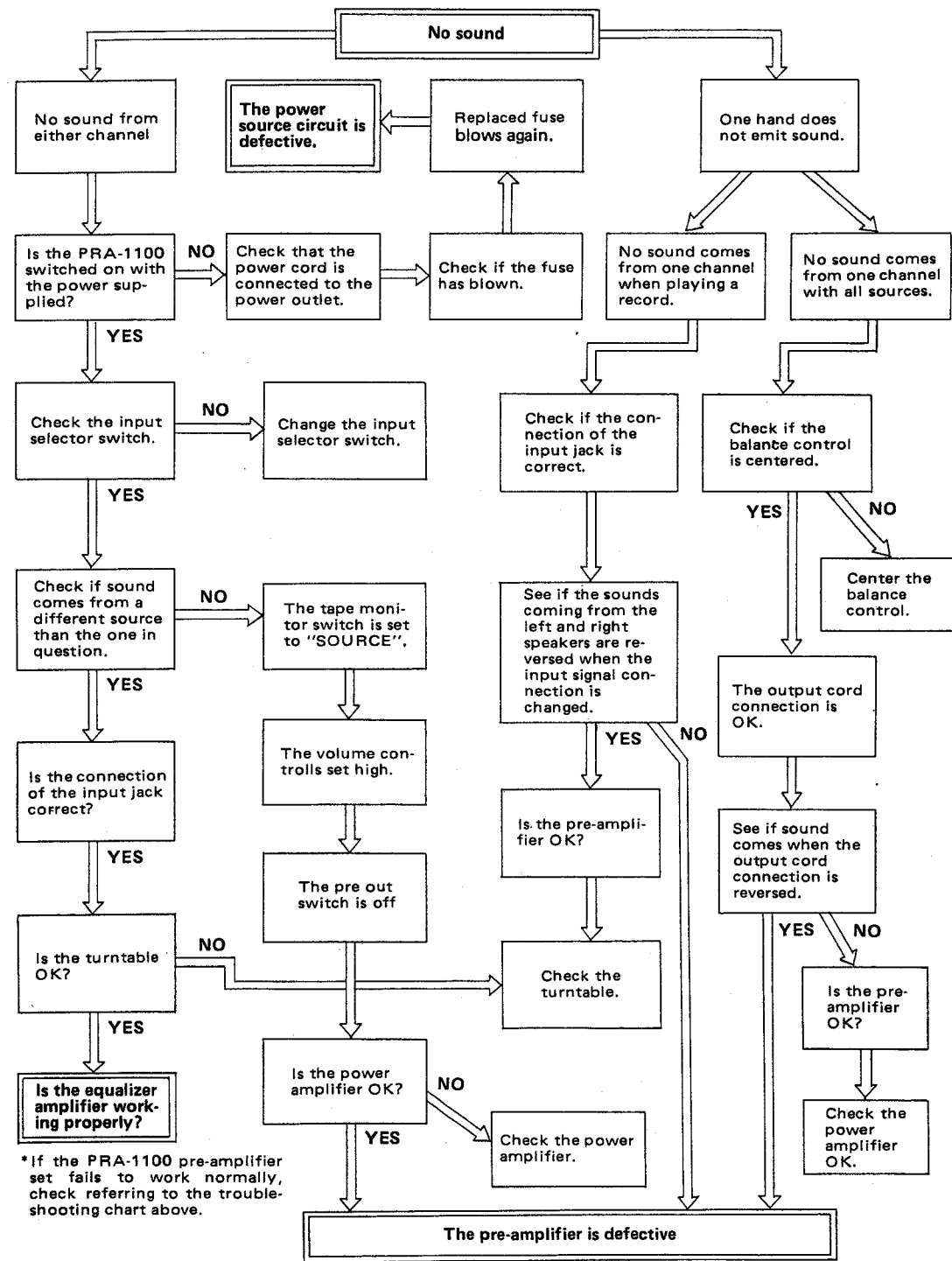

* If the PRA-1100 pre-amplifier set fails to work normally, check referring to the troubleshooting chart above.

SEMICONDUCTORS

• IC's

HD14011BP

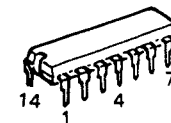

HD14011BP

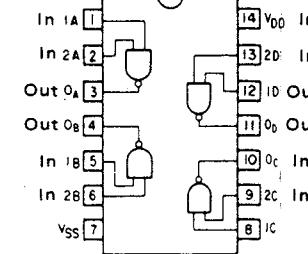

M5238P (Mitsubishi)
M5218P (Mitsubishi)
LA6458DF (Sanyo)

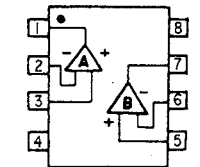
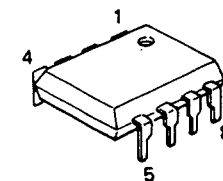

M5216L (Mitsubishi)

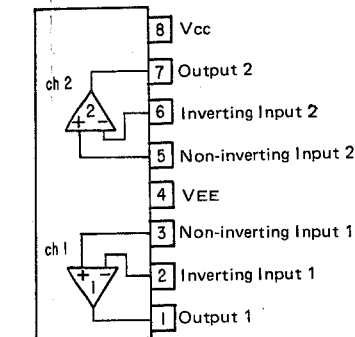
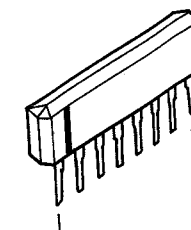

TC9152P (Toshiba)

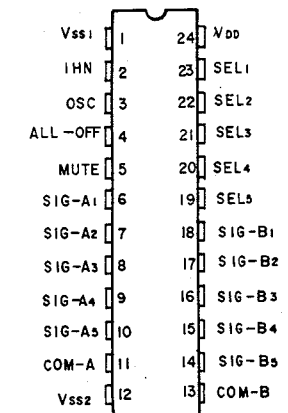

• TRANSISTORS (including FET)

2SA1015(Y)
2SC1815(BL)
2SA1015(GR)
2SC1815(Y)

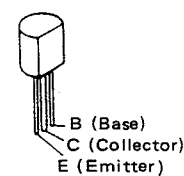

2SC2655(Y)

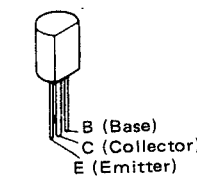

RN1202

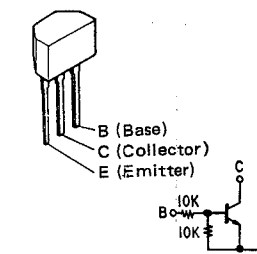

2SC3852

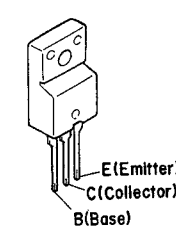

2SB834(Y)/(GR)

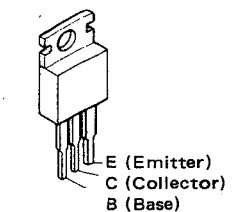

FET
2SK369(BL)/(GR)-C

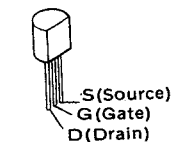

2SK246(BL/V)
2SJ103(BL/V)

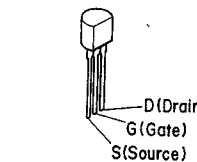

2SK381(C)/(D)
(B)/(C)

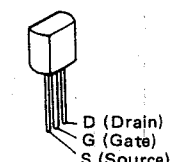

• DIODES (including LED)

1S2076A

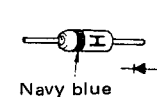

HZ5C-1
HZ18-2
HZ24-2



DSA1A2-Type-3

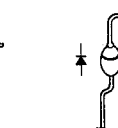

LD-701YY (YELLOW)

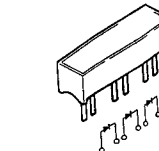

LD-603RV (RED)
LD-603DU (ORANGE)

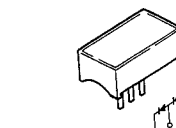

SVC321SP-ABCD
(Variable Capacitance Diode)

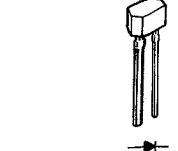

PRINTED WIRING BOARD PATTERNS AND PARTS LIST
ETC9072B MAIN UNIT PARTS LIST

Ref. No.	Part No.	Part Name & Descriptions	Ref. No.	Part No.	Part Name & Descriptions	Ref. No.	Part No.	Part Name & Descriptions	Q'ty
SEMICONDUCTORS			CAPACITORS			OTHER PARTS			
IC001	2720581004	TC9152P IC (Toshiba)	C001	2538003014	4700pF ±20% 400VAC Ceramic	F001	2229072105	P.W. Board	1
IC002	2620300007	HD14011BP IC (Hitachi)	C02A,02B	2544165014	470µF ±20% 35V Electrolytic		2090008120	Jumper Wire	150
IC101	2630257001	M-5218P IC (Mitsubishi)	C03A,03B	2544165014	470µF ±20% 35V Electrolytic		2090008117	Jumper	1
IC102	2630229013	LA-6458DF IC (Sanyo)	C004	2544165001	220µF ±20% 35V Electrolytic		2090008104	Jumper	1
IC201	2630257001	M-5218P IC (Mitsubishi)	C005	2544145005	0.47µF 50V Electrolytic		EP-5667H1	Terminal Pin L=21mm	20
IC301	2620679000	M-5238P IC (Mitsubishi)	C006	2544164031	220µF ±20% 25V Electrolytic		4150298001	Condenser Cover	1
IC302	2630229013	LA-6458DF IC (Sanyo)	C007~009	2544146004	1µF 50V Electrolytic		4170253000	Radiator	2
IC401	2630409008	M-5216L IC (Mitsubishi)	C010	2544161021	100µF ±20% 6.3V Electrolytic		4700012022	Cross Pan Screw with Sw. W 3x12	2
TR001	2730330006	2SC3852 Transistor	C011	2544135002	47µF 16V Electrolytic		2030170005	1P Contact	1
TR002	2720058013	2SB834(Y)/(GR) Transistor	C012	2544145005	0.47µF 50V Electrolytic		2020022008	Fuse Holder	2
TR003	2750043014	2SK381(C)/(D) FET	C013,014	2531024003	0.01µF +80,-20% 50V Ceramic		2061039021	Fuse 0.5A	1
TR004	2740058019	2SK381(B)/(C) FET	C015	2544172007	0.1µF ±20% 50V Electrolytic		5130815005	Fuse Label	1
TR005	2710102005	2SA1015(Y) Transistor	C016,017	2531024003	0.01µF +80,-20% 50V Ceramic		2050274004	2P Connector Base	2
TR006	2730212001	2SC2655(Y) Transistor	C018	2544146004	1µF 50V Electrolytic		2050150005	4P Connector Base	5
TR007	2730198015	2SC1815(BL) Transistor	C019	2544172007	0.1µF ±20% 50V Electrolytic		2050190065	6P NH Connector Base	2
TR008	2710102021	2SA1015(GR) Transistor	C020	2544135002	47µF 16V Electrolytic		2046017042	12P Connector Cord	1
TR012	2730198015	2SC1815(BL) Transistor	C021	2544146004	1µF 50V Electrolytic		2050243022	2P Wire Holder	4
TR015	2690025008	RN1202(10K-10K) Transistor	C024	2544132005	10µF 16V Electrolytic		2050243035	3P Wire Holder	5
TR016,017	2730198015	2SC1815(BL) Transistor	C025	2554137003	470pF ±5% 50V Plastic Film		2050243051	5P Wire Holder	3
TR019,601	2710102021	2SA1015(GR) Transistor	C026	2531052004	4700pF +100,-0% 500V Ceramic		2050256035	3P JP Connector	3
TR023	2730198015	2SC1815(BL) Transistor	C028	2531024003	0.01µF +80,-20% 50V Ceramic		2050256051	5P JP Connector	1
TR101	2750038045	2SK369(BL)/(GR)-C FET	C101,102	2412235908	200pF ±5% 50V Ceramic		2050256064	6P JP Connector	1
TR201	2750038045	2SK369(BL)/(GR)-C FET	EC101,102	255	1000pF ±5% 50V Plastic Film		2048191005	Headphones Jack	1
TR205	2730198002	2SC1815(Y) Transistor	C103,104	2551120042	2200pF ±5% 50V Plastic Film				
TR301,302	2750050010	2SK246(BL/V) FET	C105,106	2544161021	100µF ±20% 6.3V Electrolytic				
TR303,304	2750054003	2SJ103(BL/V) FET	C107,108	2554199004	1500pF ±5% 50V Plastic Film				
D001~005	2760427015	DSA1A2(Type-3) Diode	C109,110	2551140035	0.018µF ±5% 50V Plastic Film				
D006~012	2760049011	1S2076A Diode	C111,112	2554157009	3300pF ±5% 50V Plastic Film				
D014~022	2760049011	1S2076A Diode	C113,114	2544136001	100µF 16V Electrolytic				
D026,027	2760049011	1S2076A Diode	C115,116	2544161021	100µF ±20% 6.3V Electrolytic				
D028	2760249002	HZ18-2 Zener	C117,118	2544146004	1µF 50V Electrolytic				
D033	2760220021	HZ24-2 Zener	C119,120	2544147003	2.2µF 50V Electrolytic				
D035	2760236031	HZ5C-1 Zener	C121,122	2551140048	0.068µF ±5% 50V Plastic Film				
ED101,102	2760302017	SVC321SP-ABCD Diode	C123~129	2544146004	1µF 50V Electrolytic				
D201,202	2760236031	HZ5C-1 Zener	C130,131	2554199986	1000pF ±5% 50V Plastic Film				
LE001~005	3939333007	LD-603DU(Orange) LED	EC201	2544163032	1000µF 16V Electrolytic				
LE006	3939333023	LD-603RV(Red) LED	C205,206	2554139001	560pF ±5% 50V Plastic Film				
LE007	3939319021	LD-701YY(Yellow) LED	C207~210	2544146004	1µF 50V Electrolytic				
RESISTORS (not included Carbon Film ±5%, 1/4W Type)			C211,212	2534289007	68pF ±5% 500V Ceramic				
R012	2412378959	300 ohm ±5% 1/4W Carbon (NB)	C213,214	2551120026	1500pF ±5% 50V Plastic Film				
R037	2412378959	300 ohm ±5% 1/4W Carbon (NB)	C215,216	2551121038	0.012µF ±5% 50V Plastic Film				
R145,146	2440038025	560 ohm ±5% 1W Metal Oxide Film (NB)	C217,218	2534273000	15pF ±5% 500V Ceramic				
R413,414	2440033020	220 ohm ±5% 1W Metal Oxide Film (NB)	C219,220	2534281005	33pF ±5% 500V Ceramic				
VR201	2119028007	Loudness VR 100k ohm	C221,222	2551121038	0.012µF ±5% 50V Plastic Film				
VR202	2119021004	Balance VR 250k ohm	C223,224	2551140051	0.082µF ±5% 50V Plastic Film				
VR203	2119029006	Main VR (V16V35F...)	C225,226	2554131009	270pF ±5% 50V Plastic Film				
VR204,205	2119022029	Bass, Treble VR 100k ohm	C229,230	2554199986	1000pF ±5% 50V Plastic Film				
VR206,207	2116016009	Semi Fixed Resistor (100 ohm)	C301,302	2554131009	270pF ±5% 50V Plastic Film				
VR401	2119032006	Headphones VR (100k ohm)	C303,304	2534277006	22pF ±5% 500V Ceramic				
R53	2412377947	100 ohm ±5% 1/4W Carbon (NB)	C305~308	2554129008	220pF ±5% 50V Plastic Film				
			C309,310	2544146004	1µF 50V Electrolytic				
			C313,314	2544172007	0.1µF ±20% 50V Electrolytic				
			C315,316	2544161021	100µF ±20% 6.3V Electrolytic				
			C401,402	2544146004	1µF 50V Electrolytic				
			C405,406	2554121006	100pF ±5% 50V Plastic Film				
			C407,408	2531024003	0.01µF +80,-20% 50V Ceramic				
			C409~412	2544161021	100µF ±20% 6.3V Electrolytic				
			SWITCHES & RELAYS & COILS						
			EL 101,102	2359003002	FTZ Choke Coil			2	
			L301,302	2350016917	Inductor (180K)			2	
			RL001,002	2140020003	Reed Relay L23 (M)			2	
				2124409006	Power Switch			1	
			TS001~007	2124149010	Push Switch			7	
			SW001	2129521002	Slide Sw Remote (Phono)			1	
			SW002	2123623003	Rotary Slide Switch (Tape Monitor)			1	
				2124447000	1P Push Switch (Defeat)			1	
			RL601	2140039007	Relay			1	
			RL602	2140036000	Reed Relay			1	

WIRING DIAGRAM
(This figure is specifications of E2.)

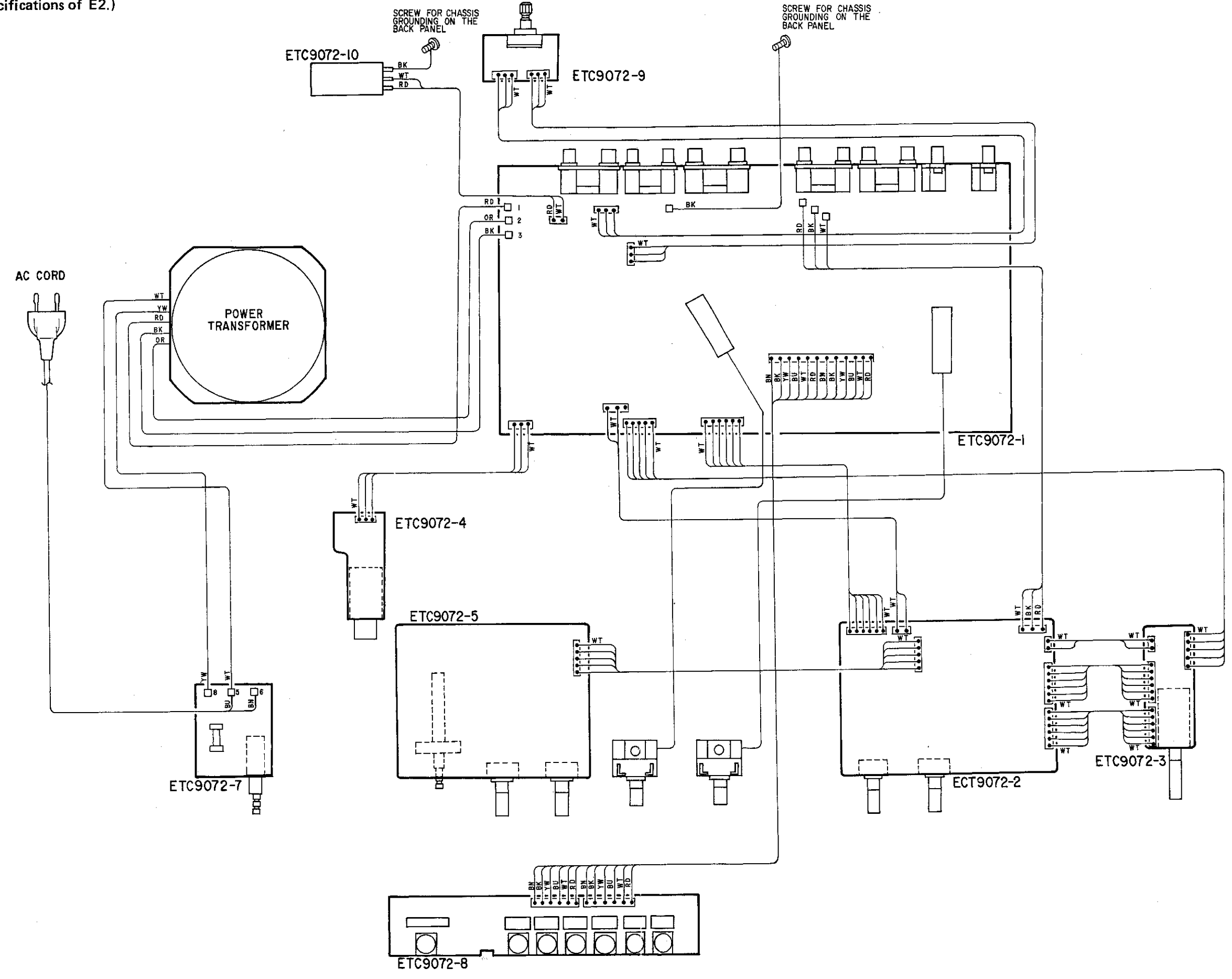

SCHEMATIC DIAGRAM

1 2 3 4 5

ETC-9072-1 EQ, POWER UNIT

ETC-9072-2 FLAT AMP UNIT / ETC-9072-3 VR UNIT / ETC-9072-4

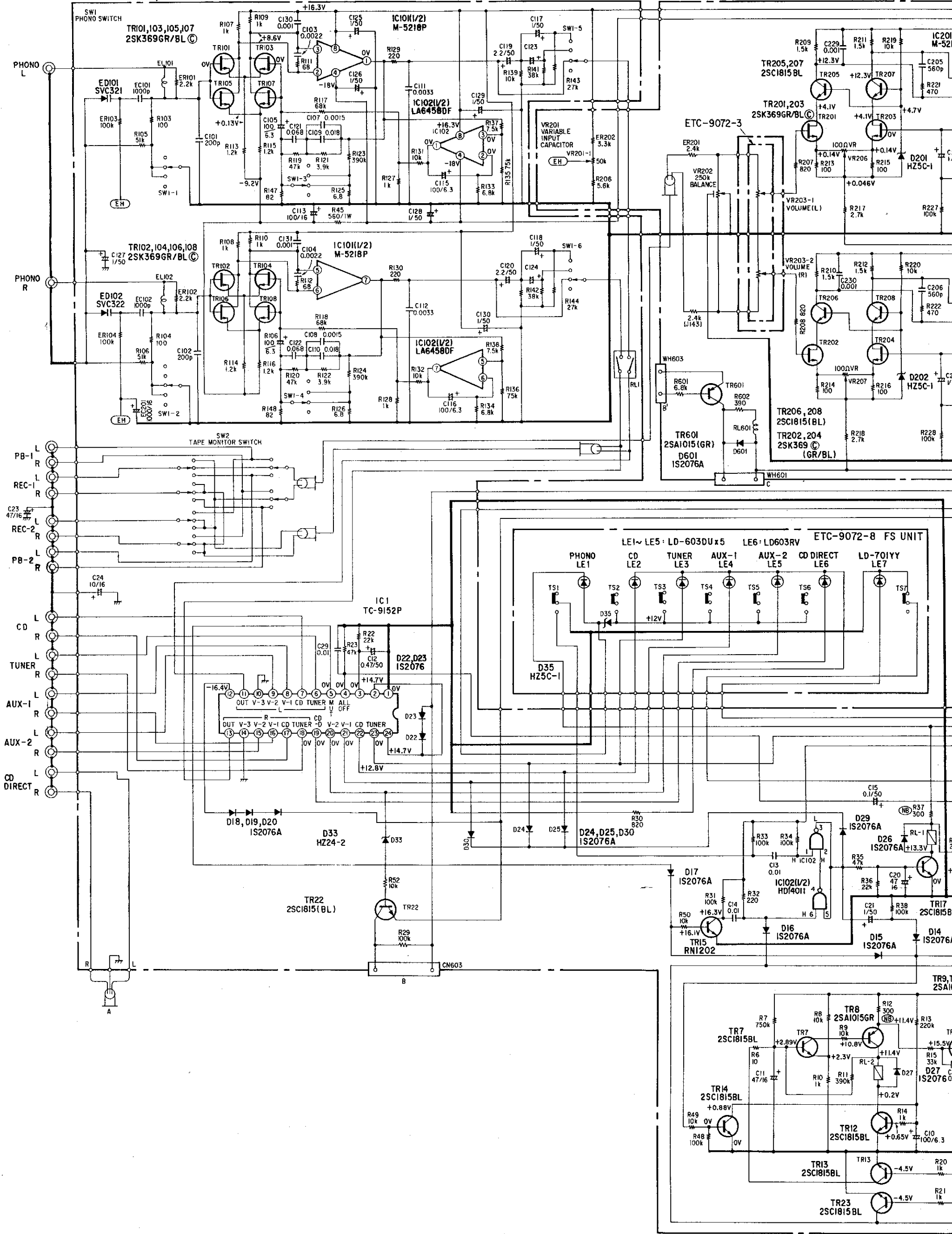

Means in when necessary, by the manufact

ETC-9072-2 FLAT AMP UNIT / ETC-9072-3 VR UNIT / ETC-9072-5 TONE UNIT

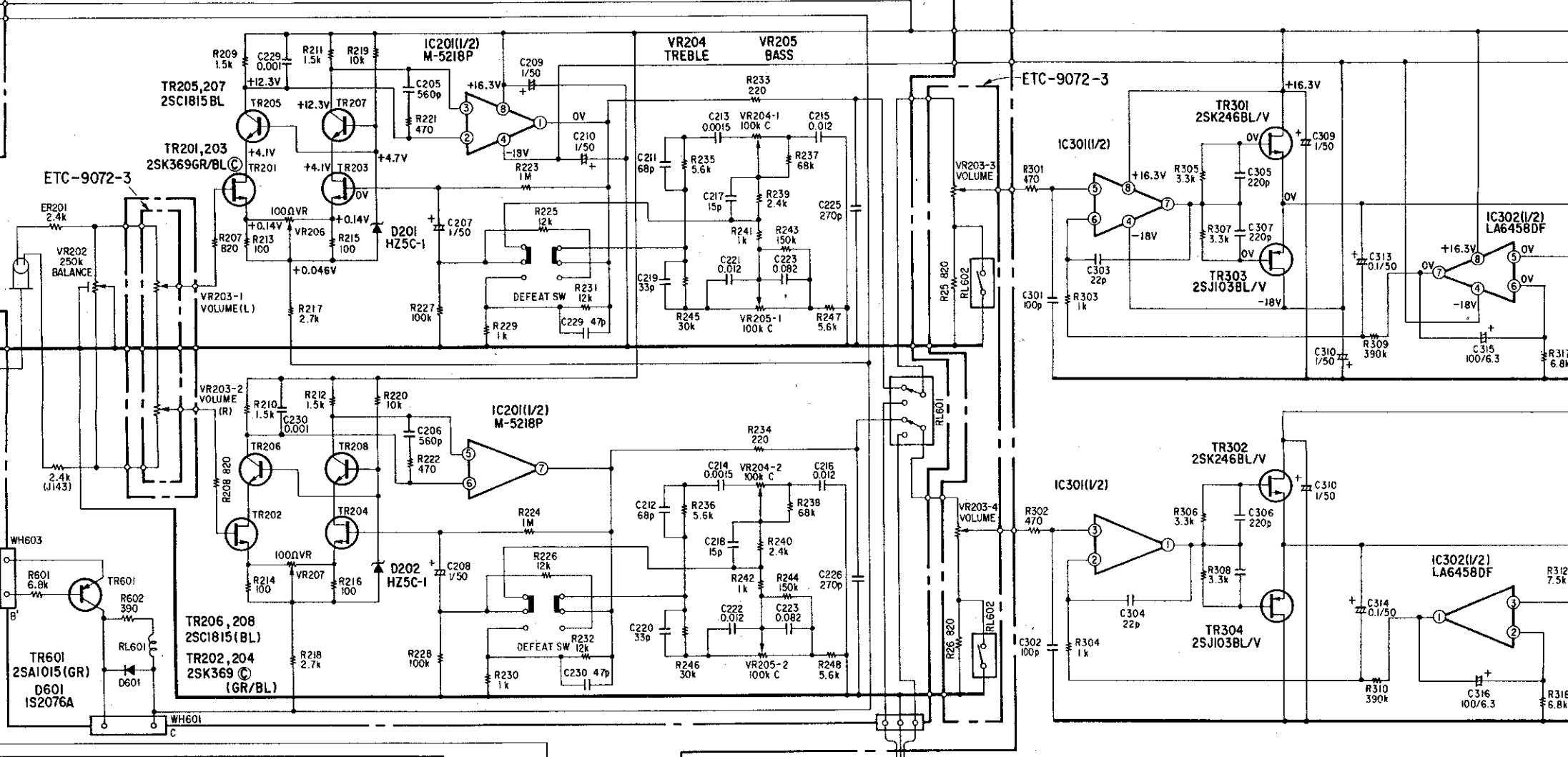

ETC-9072-8 FS UNIT

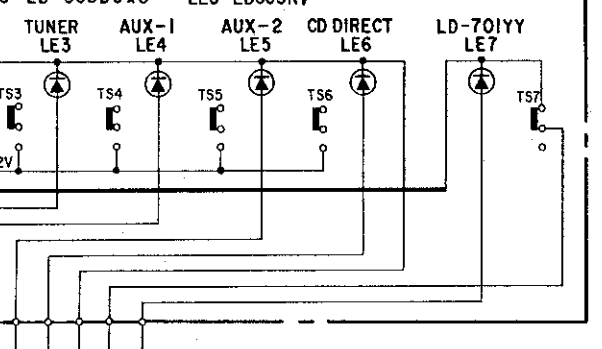

ETC-9072-3

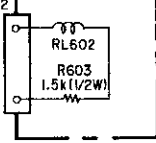

ETC-9072-9 H.P. LEVEL UNIT

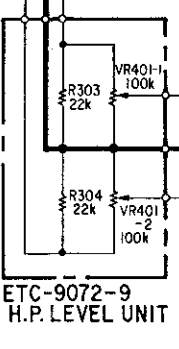

ETC-9072-10

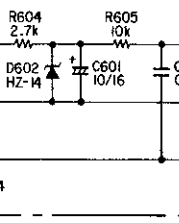

ETC-9072-7 AC SW UNIT

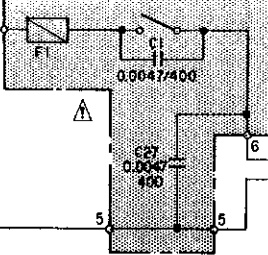

NOTES ALL RESISTANCE VALUES IN OHM ALL CAPACITANCE VALUES IN MICR EACH VOLTAGE AND CURRENT ARE CIRCUIT AND PARTS ARE SUBJECT

⚠ Means important safety item, which must be replaced, when necessary, by a part specified or meeting the specification by the manufacturer.

9072-5 TONE UNIT

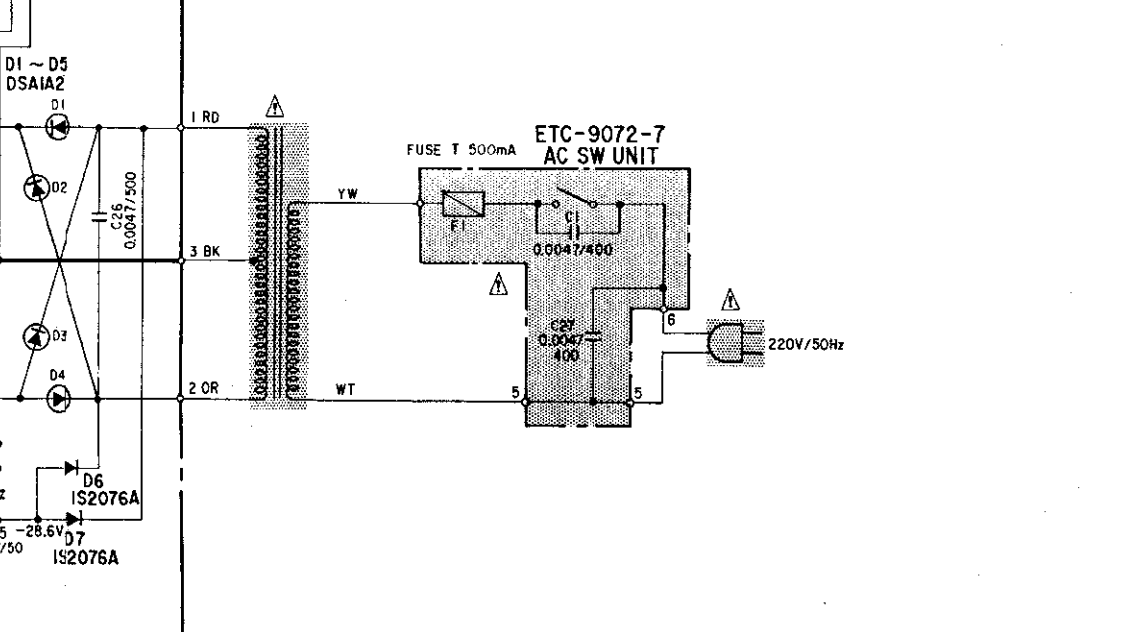
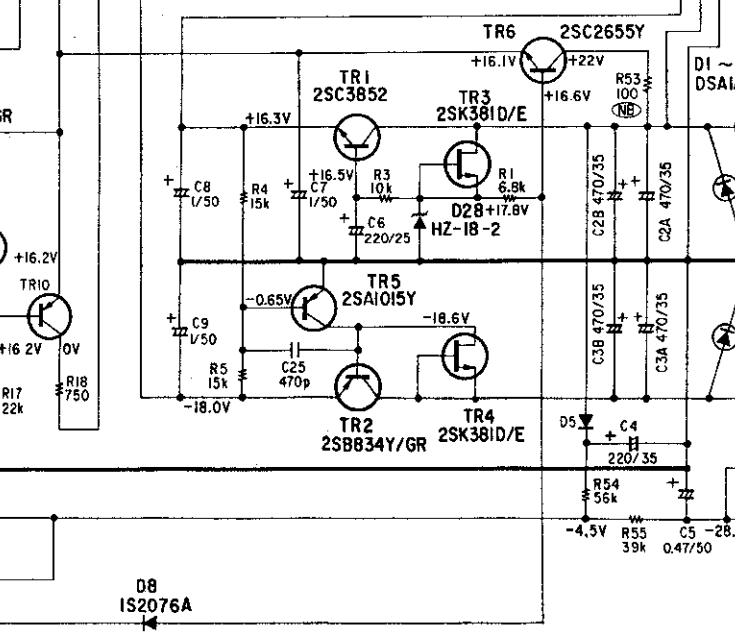
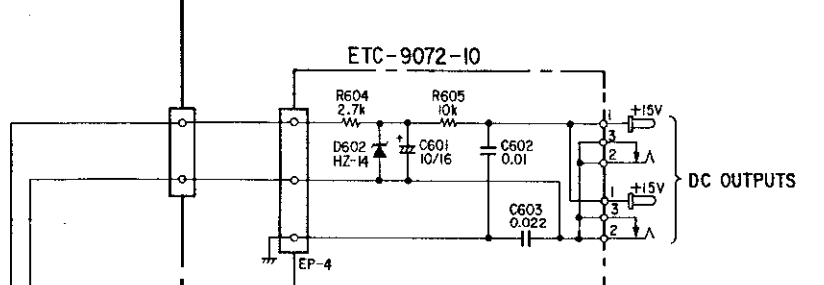
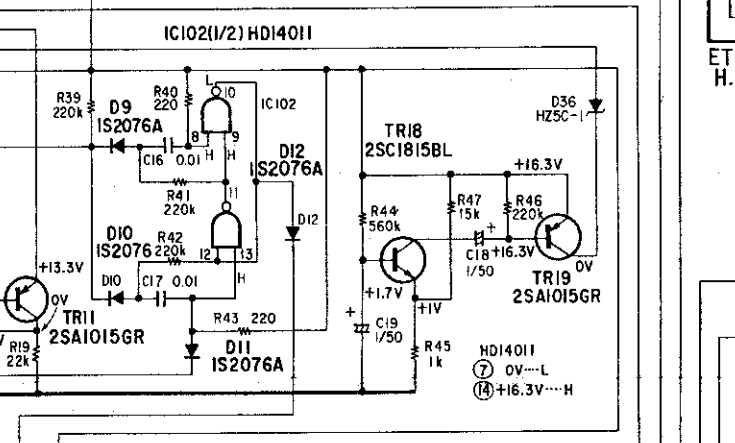
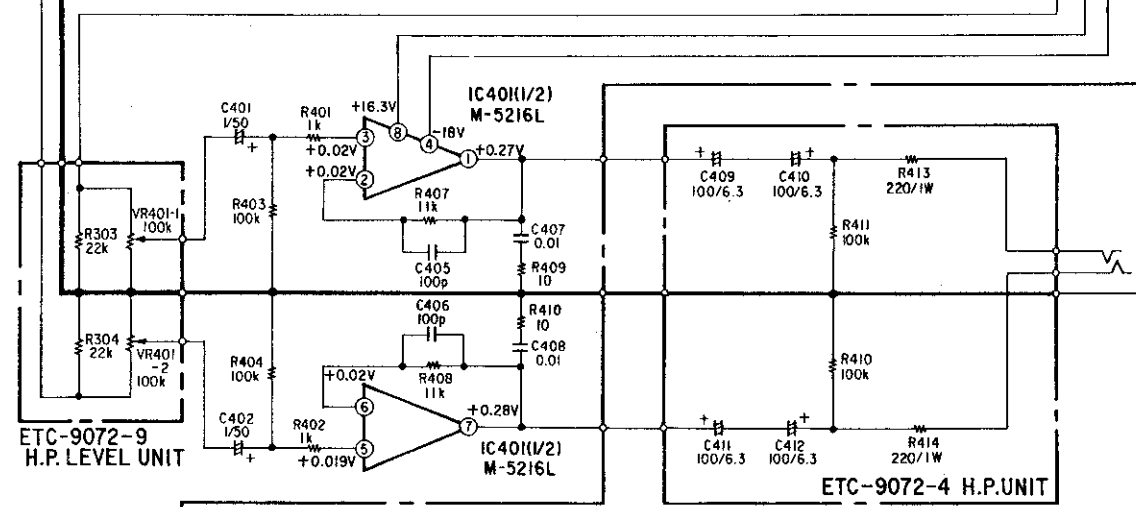
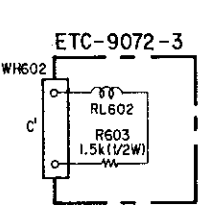
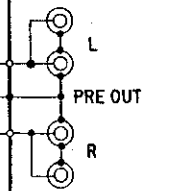
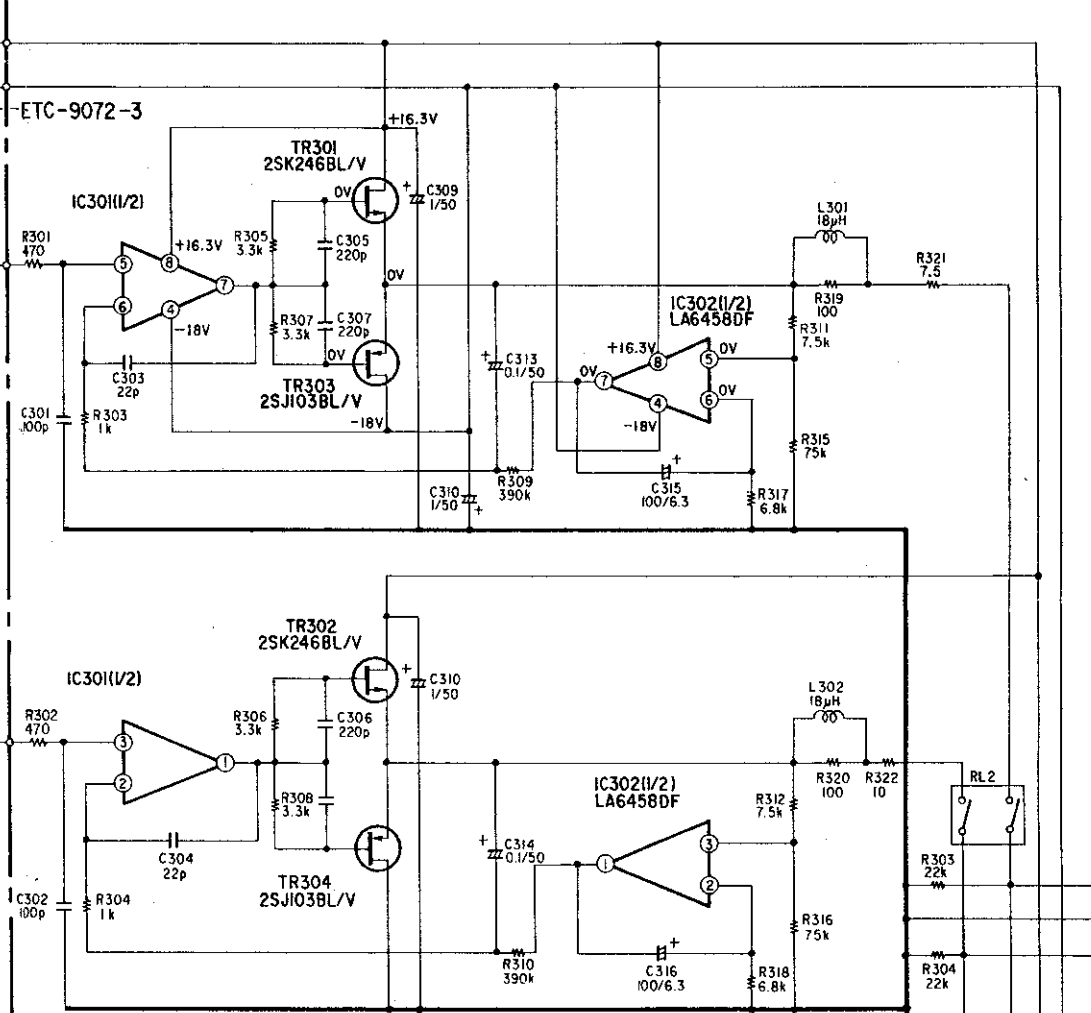
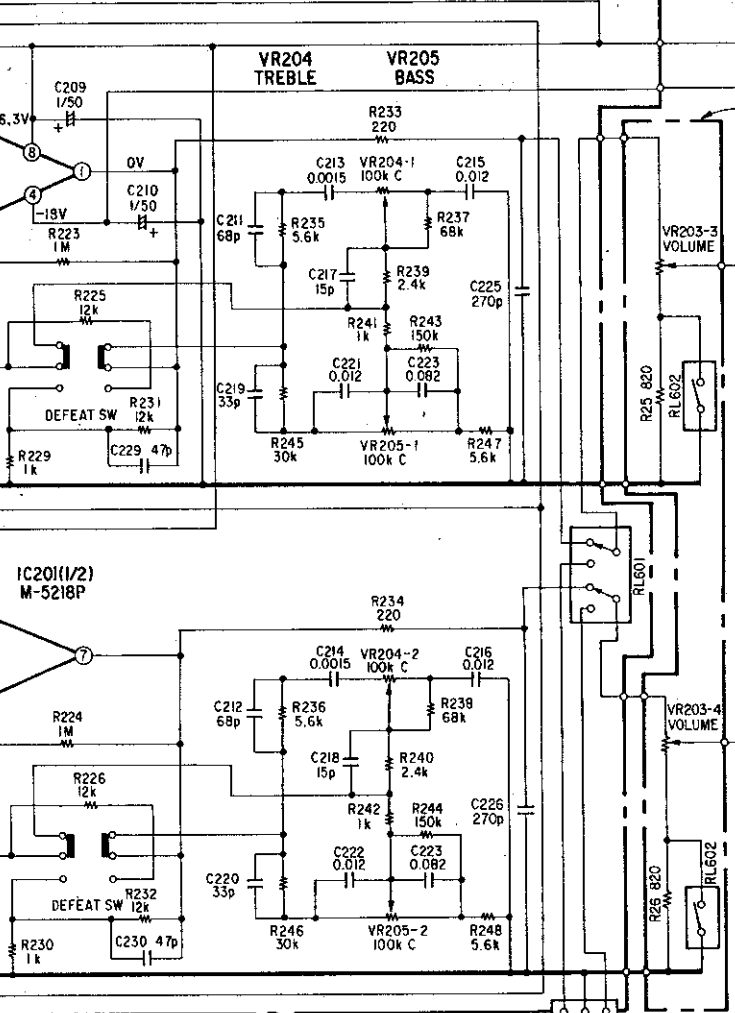

NOTES
 ALL RESISTANCE VALUES IN OHM k = 1,000 OHM M = 1,000,000 OHM
 ALL CAPACITANCE VALUES IN MICRO FARAD P - MICRO-MICRO FARAD
 EACH VOLTAGE AND CURRENT ARE MEASURED AT NO SIGNAL INPUT CONDITION.
 CIRCUIT AND PARTS ARE SUBJECT TO CHANGE WITHOUT PRIOR NOTICE.

EXPLODED VIEW OF CHASSIS AND CABINET & PARTS LIST
 • EXPLODED VIEW OF CHASSIS AND CABINET

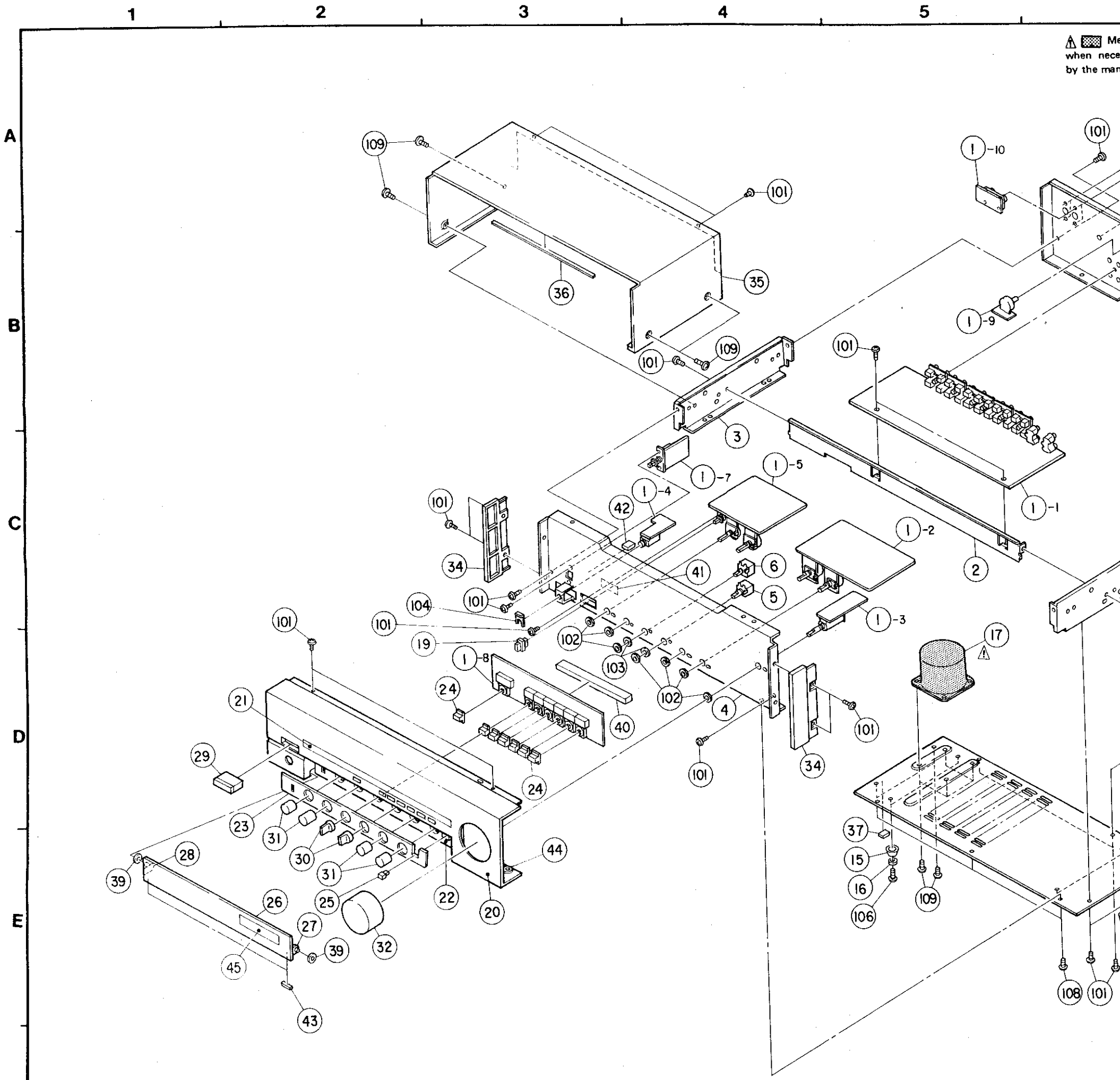

EXPLODED VIEW OF CHASSIS AND CABINET PARTS LIST

Note 1. See addendum list below for the parts with asterisk (*) on the Ref. No. and the other parts not included in the
 2. * marked not included EXPLODED VIEW OF CHASSIS AND CABINET.
 3. This list is prepared based on EU BLACK VERSION.

Ref. No.	Part No.	Part Name & Descriptions	Q'ty
1	ETC9072B	MAIN UNIT	1
2	4119030200	CENTER CHASSIS	1
3	4119027200	SIDE CHASSIS	2
4	4119032305	F. CHASSIS ASS'Y	1
5	2123614038	ROTARY REMOTE SWITCH (L=250)	1
6	2123614041	ROTARY REMOTE SWITCH (L=310)	1
7	1059069237	BACK PANEL	1
8	2062002031	AC CORD WITH PLUG	1
9	4450020005	CORD BUSH (4K-4)	1
10			
11	2538003014	4700pF ±20% 400VAC CERAMIC (C-027)	1
12	2050071016	TERMINAL ASS'Y	1
13	4770018001	WASHER (P-87)	1
14	1059059315	BOTTOM COVER	1
15	1040027107	FOOT	4
16	4619005007	LEG CUSHION	4
17	2339557002	POWER TRANS	1
18	4450033005	WIRE CLAMP BAND	5
19	1139072005	PUSH KNOB (L)	1
20	1449039408	FRONT PANEL	1
21	1419014013	WINDOW	1
22	1149006401	INNER PANEL	1
23	5139146115	SHEET	1

Ref. No.	Part No.	Part Name & Descriptions	Q'ty
24	1149005004	PUSH KNOB	7
25	4029001002	PUSH LATCH	1
26	1449038205	DOOR PANEL	1
27	4019001407	HINGE (R)	1
28	4019002406	HINGE (L)	1
29	1139088002	PUSH KNOB ASS'Y (P)	1
30	1129028108	KNOB	2
31	1129027109	KNOB	4
32	1129012127	VR KNOB ASS'Y	1
33	1129024102	VR KNOB (LEVEL)	1
34	1469063108	ESC PLATE	2
35	1029015127	TOP COVER	1
36	1229006017	SPACER	1
37	-	-	-
38	-	-	-
39	-	-	-
40	4149017031	SAFETY PLATE	1
41	-	-	-
42	4610155079	BLIND	1
43	1229013013	SPACER	2
44	4770224002	SP WASHER	-
45	5139155009	NOTICE SHEET	-
SCREWS & WASHERS & NUTS			
101	4737002034	TAPPING SCREW(S) 3x6 (BLACK)	23
102		NUT M7	7

Ref. No.	Part No.	Part Name & Descriptions
103		WASHER 7φ
104		SNAP PLATE
105	4770064107	FIXING SCREW
106	4737007039	TAPPING SCREW (S) 4x20 (BLACK)
107	4737007000	TAPPING SCREW (S) 4x8 (BLACK)
108	4737002021	TAPPING SCREW (S) 3x8 (BLACK)
109	4737007000	TAPPING SCREW (S) 4x8 (BLACK)
110	4770064107	FIXING SCREW
111	4770195005	WASHER
112	4756006008	NUT M3
PACKING & ACCESSORIES (not included EXPLODED VIEW)		
201	5040079012	STYLEN PAPER
202	5050075006	CABINET COVER
203	5039129009	CUSHION
204	5019116045	CARTON CASE
205	5050061007	ENVELOPE
206	5119189008	INST. MANUAL
207		
208	2048121004	2P PIN CORD
209	2090012006	SHORT PIN
210	5050076005	POLY COVER
211	5139111014	COLOR LABEL (BLACK)
212	5138295009	CONTROL CARD

