

DENON

Hi-Fi Component

SERVICE MANUAL MODEL **POA-5000** STEREO POWER AMPLIFIER



—TABLE OF CONTENTS —

OPERATING INSTRUCTIONS	2-8
BLOCK & LEVEL DIAGRAM	9
DISASSEMBLY INSTRUCTIONS	10-11
ADJUSTING AND CHECKING	12-13
SEMICONDUCTORS	13
P.W.BOARD OF 1U-2236 POWER AMPLIFIER UNIT	14
P.W.BOARD OF 1U-2235 INPUT/CONTROL UNIT	15
P.W.BOARD OF 1U-2237 POWER SUPPLY UNIT	16
PARTS LIST OF 1U-2236 POWER AMPLIFIER UNIT	17-18
PARTS LIST OF 1U-2235 INPUT CONTROL UNIT	18-19
PARTS LIST OF 1U-2237 POWER SUPPLY UNIT	20
PARTS LIST OF EXPLODED VIEW	20
PARTS LIST OF PACKING & ACCESSORIES	20
EXPLODED VIEW	21
WIRING DIAGRAM	22
SCHEMATIC DIAGRAM	23-24

NIPPON COLUMBIA CO., LTD.

NOTE ON USE

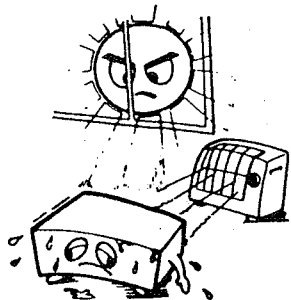

Be careful of high temperatures

- Do not place the set in a location where it will be exposed to direct sunlight or near a heating appliance.

Caution on rack/cabinet installation

- Avoid installing the set in a closed-type rack.
- When installing in a rack or cabinet, provide a sufficiently large ventilation opening to promote heat radiation.

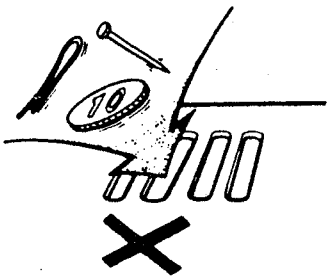

Do not allow foreign matter into the equipment

- Be especially careful of needles, hair pins, and coins getting into the set.

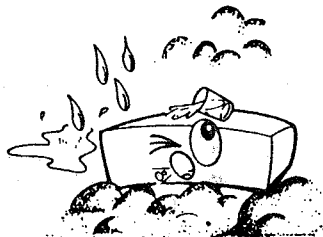

Caution on humidity, water, and dust

- Do not place the set in a location where there is high humidity or a lot of dust.

Flower vases or other items containing water should not be placed on top of the set.



Care of the case

- Avoid the use of pesticides near the set as well as wiping the case with benzene, thinner or other solvents since they may cause a change in quality or color. Use a soft cloth when wiping away dirt and follow the instructions carefully when using chemically treated cloths.

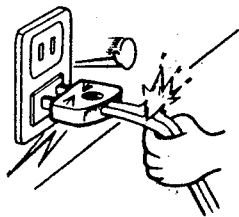

Care with the power cord

- When removing the plug from the receptacle, do not pull the power cord; be sure to hold the plug when removing it.

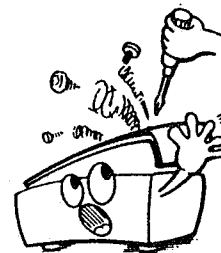

Do not open the case

- Opening the top cover or the bottom plate of the case and inserting your hand is dangerous. Do not open the case.

If some trouble arises with the performance of the set, remove the power plug soon and contact the store where the set was purchased or a nearby dealer.

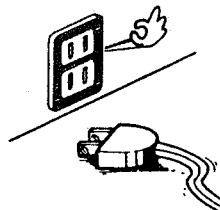

During your absence

- When not using the set for an extended period such as when taking a trip, be sure to disconnect the plug from the receptacle.

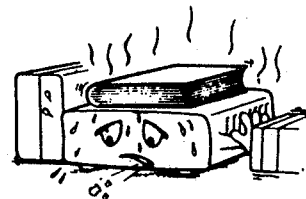

For sets with ventilation holes

Do not block the ventilation holes of the set

- Blocking of the ventilation holes will lead to damage of the set.
- The ventilation holes are very important for heat radiation from within the set. Care must be taken since placing an object against the holes will result in an extreme rise of temperature within the set.

INSTALLATION PRECAUTIONS

Install the POA-5000 horizontally. Leave at least 15 cm of space between this unit and other components on top of the amplifier.

Protective Circuit
 This set is equipped with a high speed protective circuit. This circuit protects the internal circuitry from damage due to large currents flowing when the speaker jacks are not completely connected or when an output is generated by a short circuit. This protective circuit's operation cuts off the output to the speakers. In such a case, be sure to turn the power to the set off and check the connections to the speakers. Then turn the power on again. After muting for several seconds, the set will operate normally.

Please check to make sure the following items are included with the main unit in the carton:

- (1) Operating Instructions 1
- (2) Remote connecting cable 1

SPECIFICATIONS

■ **POWER AMPLIFIER SECTION**

- **Rated output power:**

STEREO:	FRONT	100 W + 100 W (8 ohms load, T.H.D. 0.02%) 140 W + 140 W (6 ohms load)
	CENTER	50 W + 50 W (8 ohms load, T.H.D. 0.02%) 70 W + 70 W (6 ohms load)
	REAR	50 W + 50 W (8 ohms load, T.H.D. 0.02%) 70 W + 70 W (6 ohms load)
MONAURAL:	FRONT	200 W (8 ohms load, T.H.D. 0.02%)
	CENTER	100 W (8 ohms load, T.H.D. 0.02%)
	REAR	100 W (8 ohms load, T.H.D. 0.02%)
- **Total harmonic distortion:** STEREO/MONAURAL: 0.008% (20 Hz ~ 20 kHz, -3 dB at rated output, 8 ohms)
- **Intermodulation distortion:** STEREO/MONAURAL: 0.005% or less (7 kHz/60 Hz = 1/4 at a load of 8 ohms and amplitude output equivalent to the rated output)
- **Power bandwidth:** STEREO/MONAURAL: 5 Hz ~ 50 kHz (T.H.D. 0.05%, -3 dB at rated output, 8 ohms)
- **Frequency response:**

STEREO:	1 Hz ~ 100 kHz (At a load of 8 ohms and 1 W output)
MONAURAL:	2 Hz ~ 80 kHz (At a load of 8 ohms and 1 W output)
- **Input sensitivity:**

STEREO:	1 V
MONAURAL:	0.7 V
- **Input impedance:**

STEREO:	47 kohms
MONAURAL:	47 kohms
- **Output impedance:**

STEREO:	0.08 ohms (1 kHz)
MONAURAL:	0.16 ohms (1 kHz)
- **S/N ratio (IHF a Network):**

STEREO:	118 dB
MONAURAL:	113 dB

■ **GENERAL**

- **Power supply:** AC 120 V/60 Hz (for U.S.A. model)
AC 110/220 V 50/60 Hz (for multi-voltage model)
- **Power consumption:** 6.0 A (for U.S.A. model)
450 W (for multi-voltage model)
- **Dimensions:** 434 (W) × 185 (H) × 415 (D) mm
(17-3/32") × (7-9/32") × (16-11/32")
- **Weight:** 24.2 kg (53 lbs 6 oz)

* Specifications and design are subject to change without notice for the purpose of improvement.

CONNECTIONS

[When used for stereo operation]

Preamplifiers for surround and other reproduction equipment

AVP-5000 connection examples (When connecting another preamplifier, see the accompanying instruction manual.)

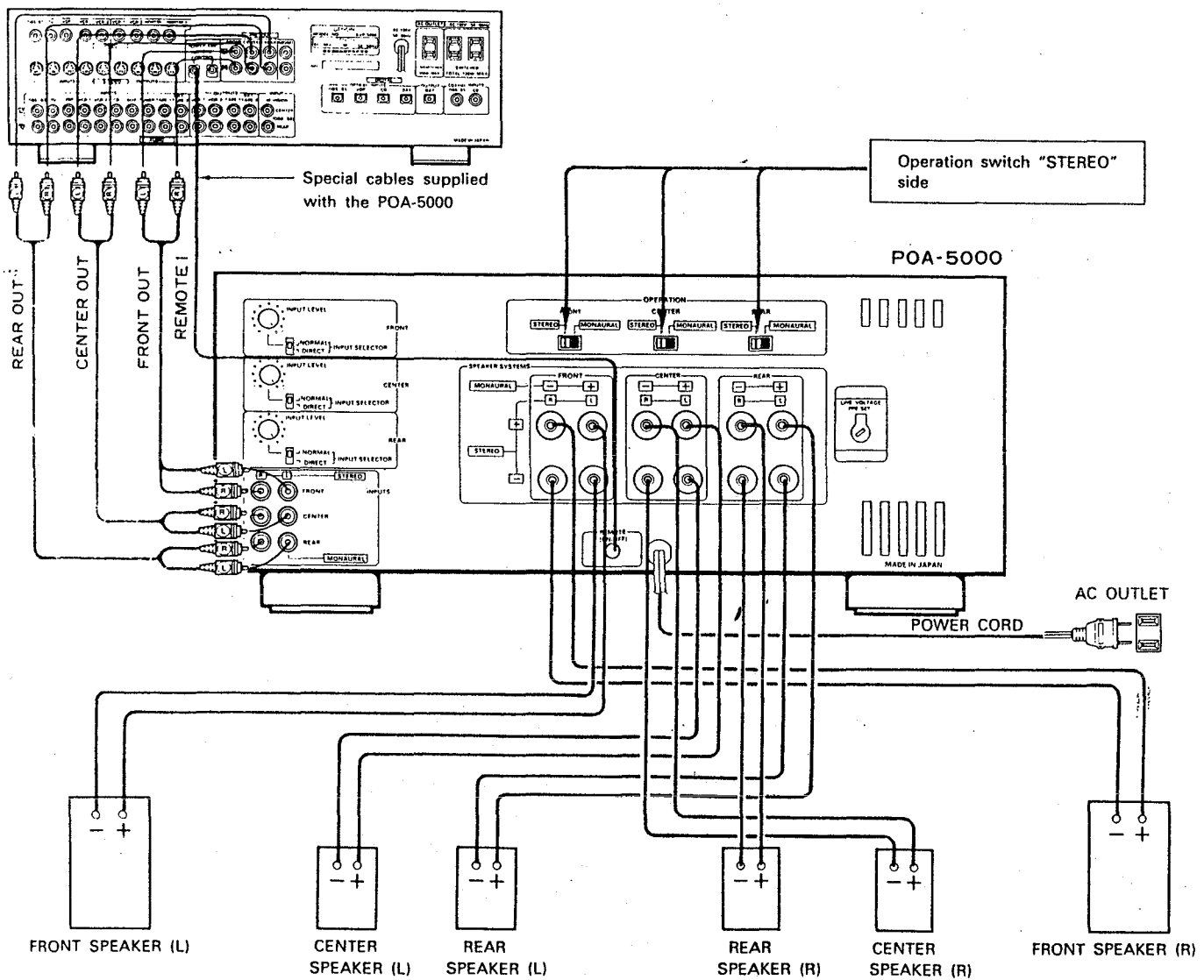

Precautions When Making Connections

- Do not plug the power cord into the power outlet until all the connections have been completed.
- After checking the left and right channels, make proper connections: L with L, and R with R.
- Insert the plugs securely. Incomplete connections will cause noise to be generated.
- Note that bundling pin-plug cords with the power cord or placing pin-plug cords close to the power transformer might lead to the occurrence of hum or noise.

NOTE:

- Be sure to switch off the power before changing the position of the operation switch.
- The connection method for the speakers will differ with stereo and monaural operation.
- When the settings of the operation switches are made separately for each of FRONT, CENTER, and REAR, the input and speaker output connections must be made to match the stereo/monaural operation of the various sections.

[When used for monaural operation]

Preamplifiers for surround and other reproduction equipment

AVP-5000 connection examples (When connecting another preamplifier, see the accompanying instruction manual.)

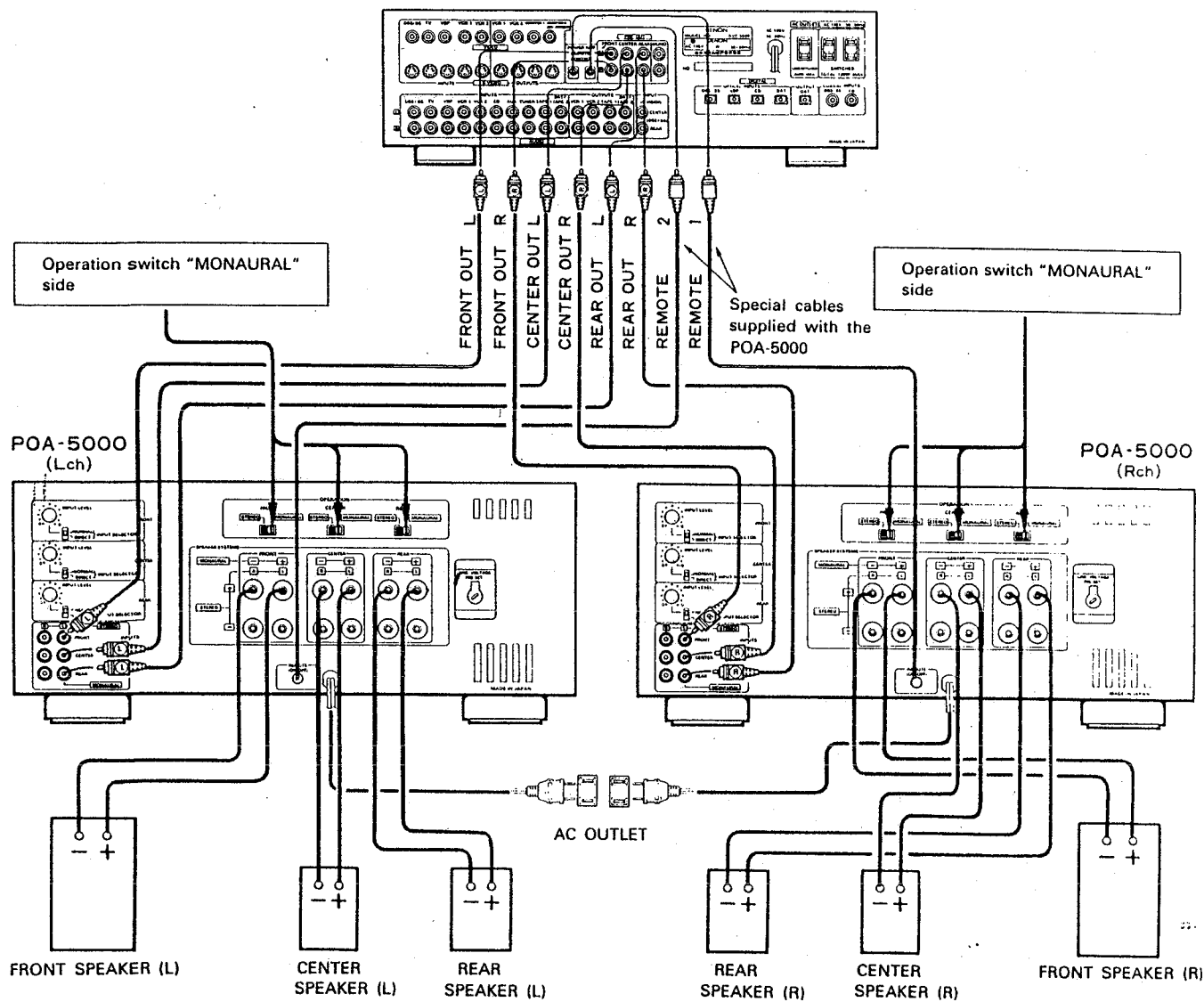

- ① Peel the insulation off the end of the cord.
- ② Twist the conductors
- ③ Turn the speaker terminals counterclockwise to loosen them.
- ④ Insert the conductor section of the cord all the way into the terminal and tighten the terminal in the clockwise direction.

Speaker Terminal Connections

Twist the conductors tightly or otherwise process the ends.

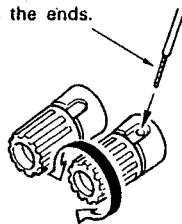

Banana Plug Connections

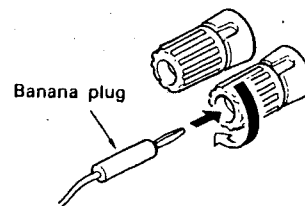

Tighten the terminal by turning clockwise, then insert the banana plug.

NAMES AND FUNCTIONS OF THE PARTS

Front Panel

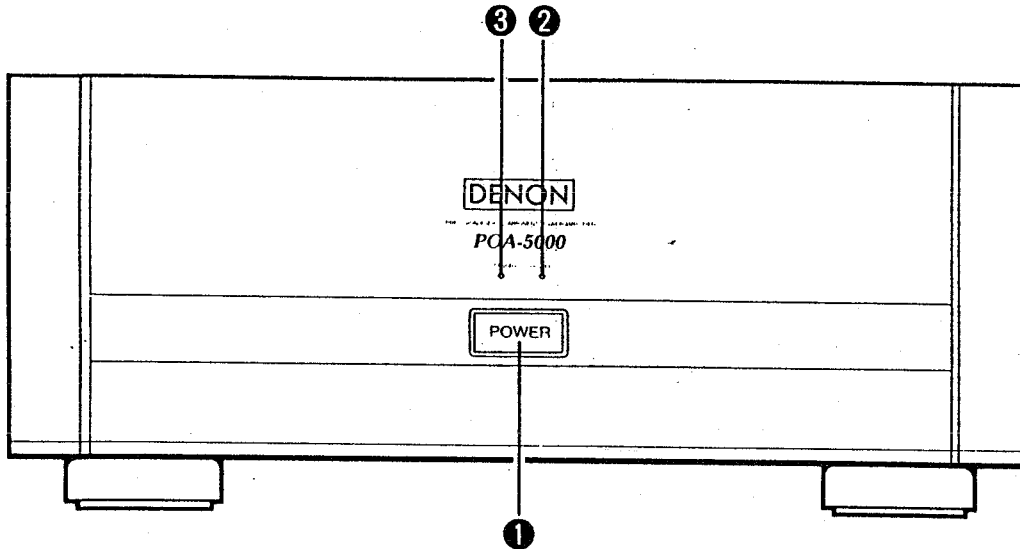

1 POWER (Power switch)

Pressing this switch causes the POWER indicator 2 to light and the power to be switched on. The muting circuit will operate for several seconds to prevent the noise that arises when the power is switched on, then the amplifier will enter the normal operating condition.

Connecting the output of a DENON component equipped with a REMOTE output to REMOTE input 3 of the rear panel in this condition (using the remote cable supplied with this amplifier) will allow the operating condition of the amplifier to be switched to standby or normal operation, synchronized with the power on/off state of the component at the other side. Pressing the POWER switch once again will cause the indicator to go off and the power to be switched off.

2 POWER (Power indicator)

The indicator lights up (red) when the power is on and goes off when the power is switched off.

3 STANDBY (Standby display)

This indicator lights up (orange) to indicate the standby condition when the power is switched off with the component of the other side which is connected with the remote cable.

NOTE:

- When you will be away for a long period such as when on a trip, set the POWER switch of this amplifier to the off position, rather than use the standby condition.

• LINE VOLTAGE (Voltage select switch) . . . For Multi-voltage model only.

- * The desired voltage may be set with the VOLTAGE SELECTOR KNOB on the back panel using a screw driver.
- * Do not twist the VOLTAGE SELECTOR KNOB with excessive force. It may be damaged.
- * If the voltage select switch does not turn smoothly, see qualified serviceman.

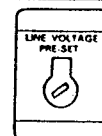

Rear Panel

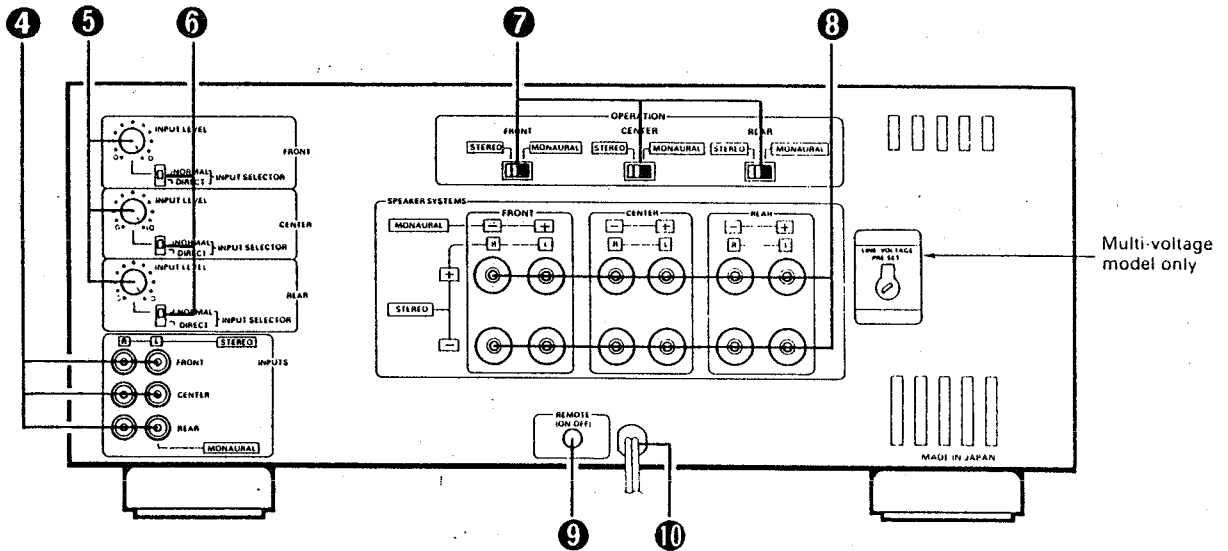

- 4 INPUTS (Input jacks)**
These are the input jacks for each of the FRONT, CENTER, and REAR sections. Make connections to correspond with each output of an AV surround preamplifier, etc. When OPERATION switch 7 is set to MONAURAL, the left channel side becomes a monaural input jack. Do not connect the right channel side at this time.
- 5 INPUT LEVEL (Input level controls)**
These controls are used to adjust the input level of each of the inputs: FRONT, CENTER, and REAR.
- 6 INPUT SELECTOR (Input selection switches)**
Set to the "NORMAL" side when using the INPUT LEVEL controls 5. This allows input level adjustments to be made. Setting to the "DIRECT" side makes the input signal bypass the input level control and applies the signal directly to the power amplifier to provide even higher quality reproduction.
- 7 OPERATION (Operation switch)**
This switch provides switching between stereo and monaural operation to correspond with each input of the FRONT, CENTER, and REAR sections.

NOTE:

- This amplifier permits a bridged connection (BTL) of the 2 amplifiers (of the left and right channels) for monaural operation which uses a positive and negative polarity amplifier.

- **"STEREO"**
The amplifier is set to this position before being shipped from the factory. This setting provides 2-channel (left and right) stereo operation for each input.
- **"MONAURAL"**
This setting uses the monaural input jack (left channel side) for monaural operation with each input.

NOTE:

- The switches are equipped with covers to prevent erroneous operation. Use a flat-bladed screwdriver with a thin tip from the space at the top side, and be sure to perform the switching with the power off.
- Note that the connection method of the input jacks and the speaker terminals will differ depending on stereo or monaural operation. (See the connection diagrams on Pages 6 and 7.)
- This amplifier contains a 2-channel power amplifier for each of the FRONT, CENTER, and REAR sections for a total 6-channel structure. Selection of stereo or monaural operation with each OPERATION switch allows this amplifier to be used as a 6-, 5-, 4-, or 3-channel power amplifier.

- 8 SPEAKER SYSTEM (Speaker connection terminals)**
Connect the speaker cords here. Be sure to connect the same polarity speaker system and amplifier speaker terminal (that is, (+) with (+), and (-) with (-)).

NOTE:

- The speaker connection method will differ for stereo and monaural operation. (See the connection diagrams on Pages 4 and 5.)

- 9 REMOTE (Power Supply Remote Input Jack)**
Connect this jack with a DENON component equipped with a REMOTE (power supply remote output) jack. Use the special cable supplied with this amplifier for the connections.

- 10 Power Cord**
Plug this cord into the power outlet.

TROUBLESHOOTING

1. Have all connections been made PROPERLY?
2. Have you followed all operational instructions correctly?
3. Check speaker and the preamplifier systems for proper operation.

When your unit does not seem to be operating correctly, first check the items in the following table. If the symptom does not correspond to any of the problems as shown below, turn off the power sources immediately and contact your DENON dealer.

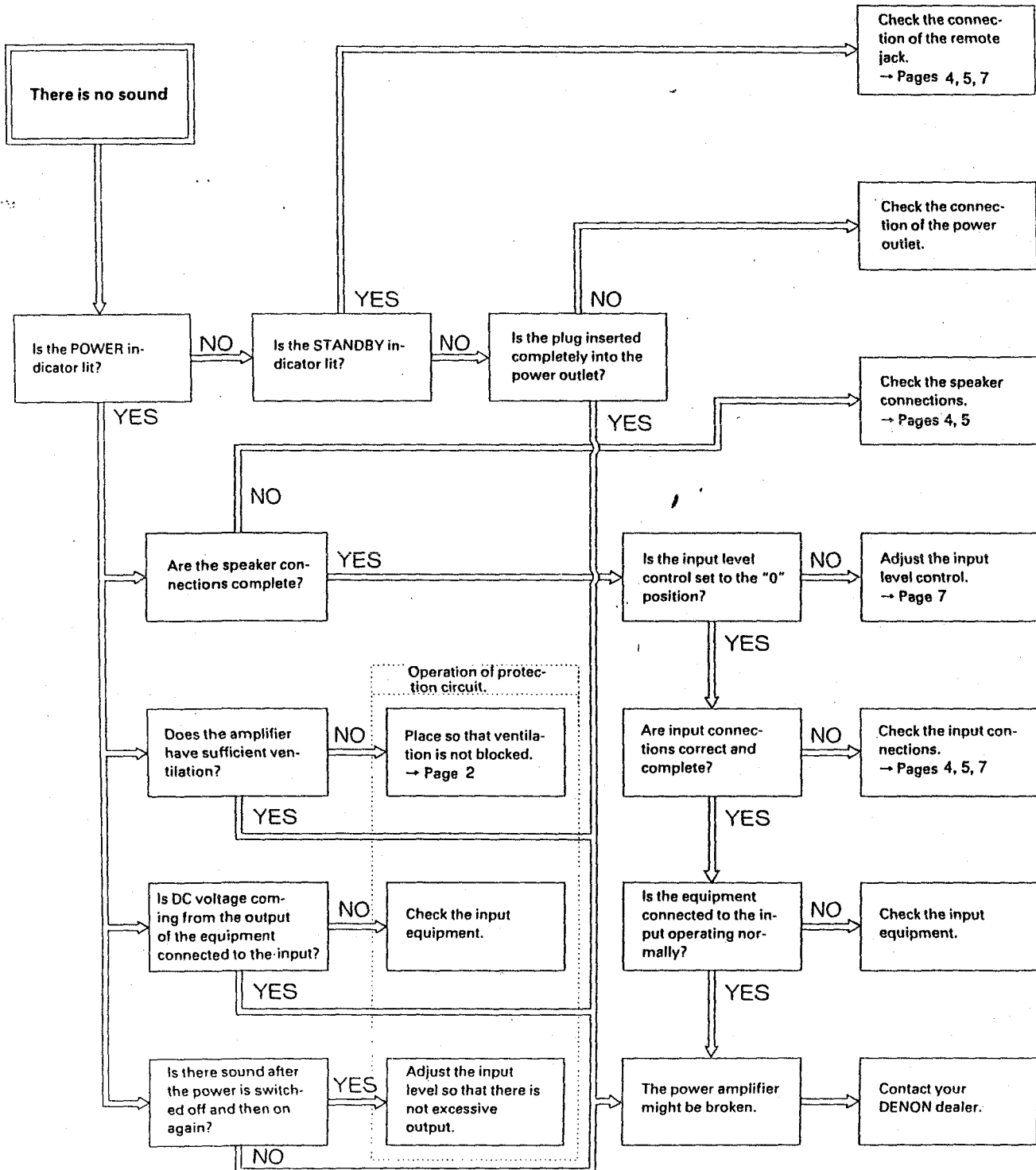

BLOCK & LEVEL DIAGRAM

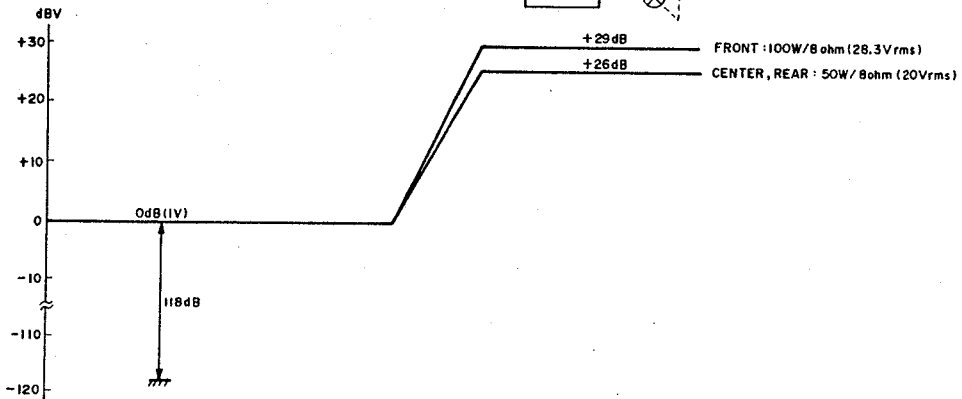
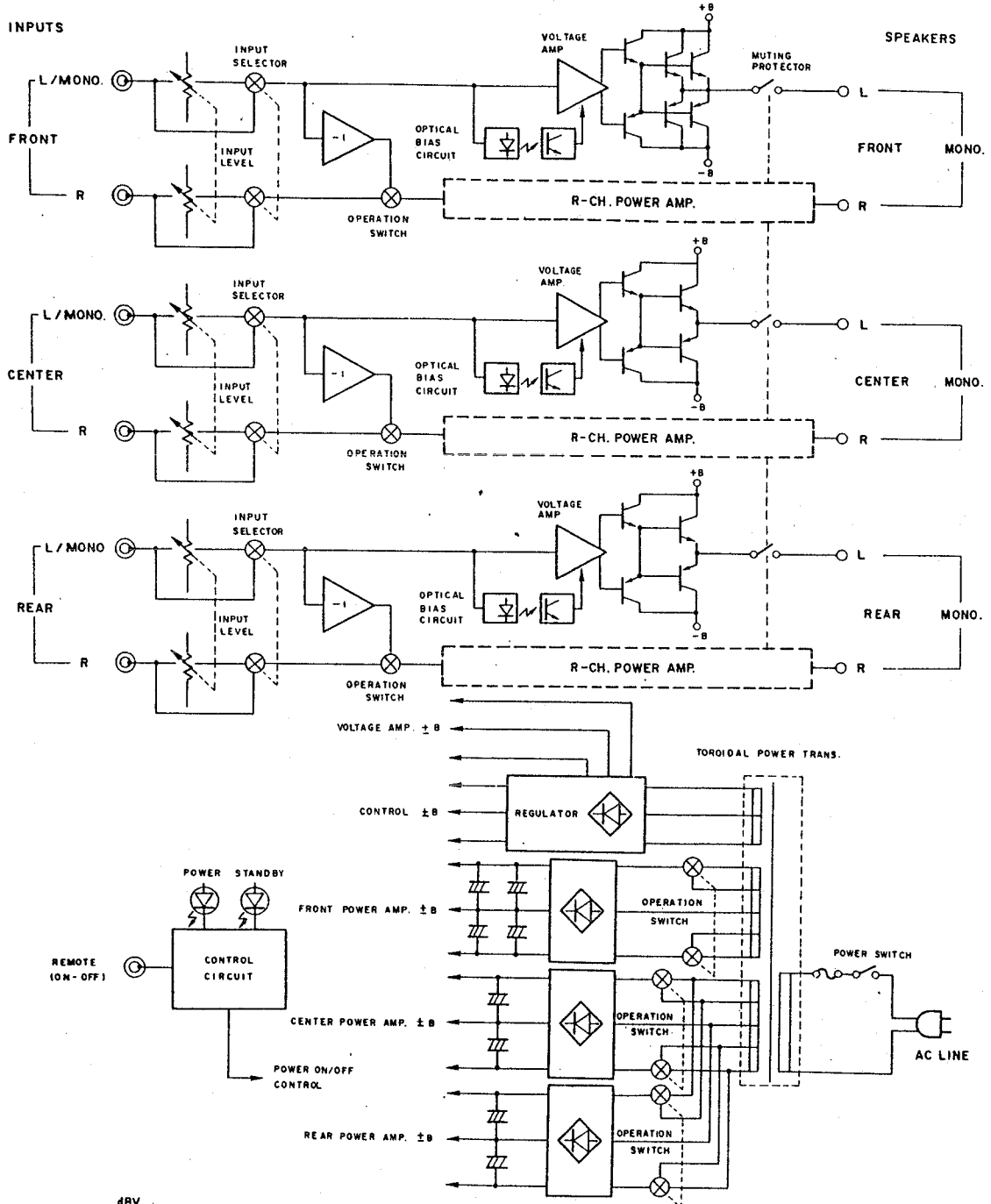

DISASSEMBLY INSTRUCTIONS

1. Top Cover and Bottom Cover

- 1) Remove 8 screws on both sides and 4 screws on rear side. Stretch side plates of Top Cover sidewise, and pull up Top Cover in arrow direction.
- 2) Remove 20 screws and detach Bottom Cover.

Note) 8 Zinc coated screws are attached on right and left of Bottom Cover. Do not remove those screws.

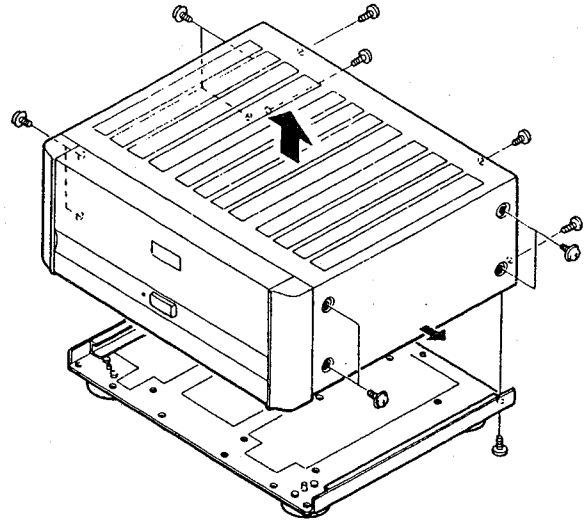

2. Front Panel

After pulling out power switch knob to front, remove 5 upper screws on Front Panel and pull Front Panel in arrow direction.

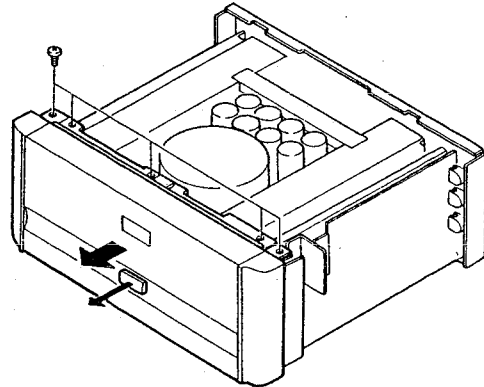

3. Power Unit (Left/Right)

Remove 2 screws (A) and detach Heat sink tank supporter. Secondly, remove 4 front screws (B) and 4 rear screws (C), then detach left and right Power Unit in arrow direction respectively.

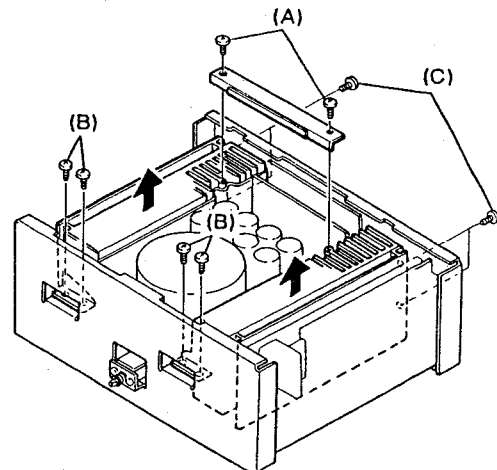

4. Input P.W.B.

- 1) Take off 3 knobs of volume knob (FRONT, CENTER, REAR) of input level which is located on rear side.
- 2) Remove rear 2 screws (A) fixing input volume holder to body, and remove 2 rear screws(B) fixing input terminal (RCA Jack).
- 3) Remove 2 screws (C) fixing input P.W.B. and detach P.W.B. from holder (D) on two places. Then pull out P.W.B. in arrow direction.

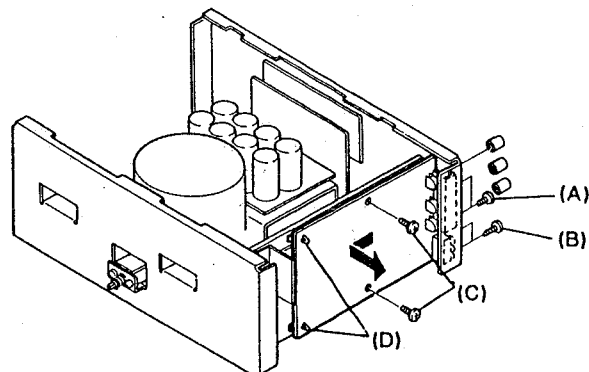

5. Power Unit and Speaker Terminal

- 1) Remove 8 screws fixing power transformer.
- 2) Remove 4 screws (A) of holder fixing power P.W.B.
- 3) Remove rear 2 screws (B) and detach switch guard of operation switch.
- 4) Remove 6 screws (C) fixing operation switch.
- 5) Remove 3 screws (D) fixing Speaker terminal.
- 6) Remove terminals of transformer, power unit, and speaker in arrow direction.

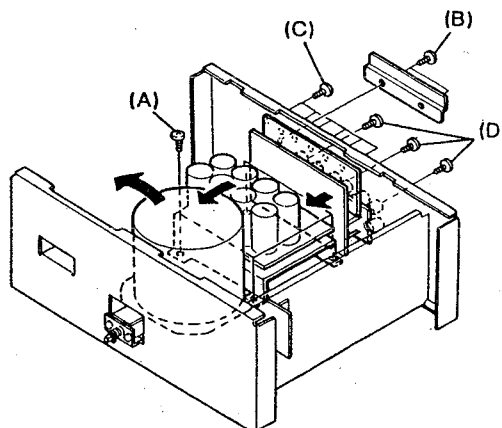

ADJUSTING AND CHECKING

● Adjustment of idling current.

1) Measurement instruments required for adjustment.

* Digital voltmeter *Low frequency oscillator

2) Preset

1)Place the unit where having normal use conditions avoiding abnormally ventilated places such as nearby electric fans.

2)Set knobs, switches and others as follows:

- POWER (Power switch) → OFF (●)
- Rear side INPUT LEVEL (Volume control knob) → (∞) minimum
- Rear side SPEAKER SYSTEM (Speaker terminal) → No load (no connection with speakers, dummy resistors, etc.)
- Rear OPERATION SWITCH (Operation shifting switch) → STEREO

3) Adjustment

1)Initial setting.

- Remove Top Cover and set semi-fixed volume of Power Amplifier (1U-2236-1,-2),VR501, 502, 503, 504, 601, 602, 603, 604, 701, 702, 703, 704 at center position.

2)Idling current adjustment.

- Connect DC voltmeter to each test point (T.P.) of FRONT, CENTER,REAR and each of L/R channels, and turn Power switch "ON" (●) and turn semi-fixed volume for each channel to set to voltage values in Table 1.

Table 1

Adjust channel		Adjust spot	Test point	Adjust voltage value (DC)	
				Immediately after power ON	After 10 min.
FRONT	L	VR501	FRONT-L	1±0.5mV	10±1mV
	R	VR502	FRONT-R	1±0.5mV	10±1mV
CENTER	L	VR601	CENTER-L	1±0.5mV	4±1mV
	R	VR602	CENTER-R	1±0.5mV	4±1mV
REAR	L	VR701	REAR-L	1±0.5mV	4±1mV
	R	VR702	REAR-R	1±0.5mV	4±1mV

Note)Adjust voltage value between test points denotes the absolute value.

3)Adjustment of "Optical class A " idling current.

- Connect low frequency oscillator to each input terminal of each L/R channel of FRONT,CENTER,REAR, and input sine wave of 50m Vrms 1KHz.
- Set rear side INPUT LEVEL volume maximum (∞) at that time confirm that indication of DC voltmeter are increasing by steps from the adjust values in Table 1.
- Adjust voltage of each channel according to Table 2.

Adjust channel		Adjust spot	Test point	Adjust voltage value (DC)	
				Immediately after the increase	After 10 min.
FRONT	L	VR503	FRONT-L	40±5mV	55±2mV
	R	VR504	FRONT-R	40±5mV	55±2mV
CENTER	L	VR603	CENTER-L	45±5mV	60±2mV
	R	VR604	CENTER-R	45±5mV	60±2mV
REAR	L	VR703	REAR-L	45±5mV	60±2mV
	R	VR704	REAR-R	45±5mV	60±2mV

Note)Adjust voltage value between test points denotes the absolute value.

Table 2

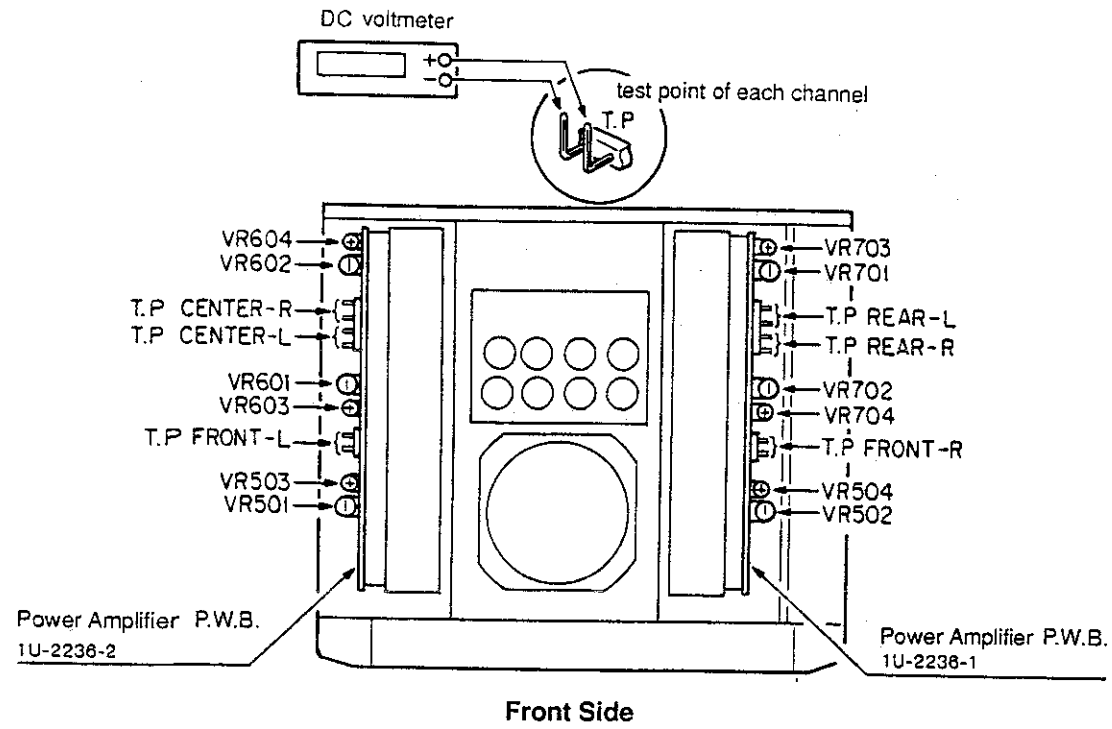

- Confirmation of neutral point voltage.
 - 1) Connect a DC voltmeter to speaker terminal.
 - 2) Turn power on for the unit.
 - 3) Set rear side INPUT LEVEL volume at maximum (⤴).
 - 4) Confirm that voltage of digital voltmeter is within the range of ± 100 mV (for each channel L/R).

SEMICONDUCTORS

● IC

TLP521-1 (BL)

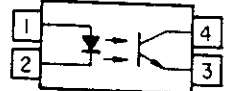
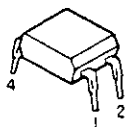

NJM4558DD
NJM2068DAC
NJM2028DD

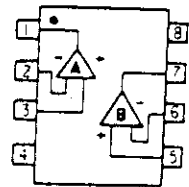

● Transistors

2SA988 (E/F)
2SC1841 (E/F)
2SD1111

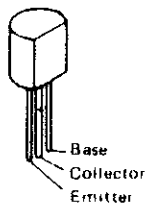

2SA1145 (O)/(Y)
2SC4208A
2SD667A (C)
2SC2705 (O)/(Y)

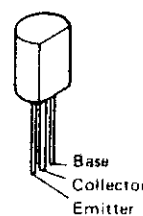

2SA1048 (GR)
2SC2458 (BL)

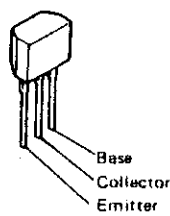

RN1202 (10k-10k)
RN1205 (2.2k-47k)
RN2202 (10k-10k)

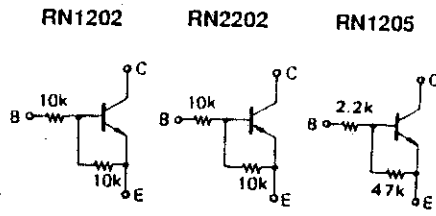
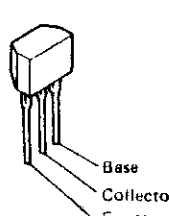

2SA1240 (F/G)

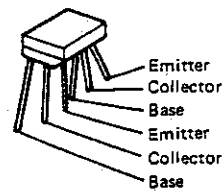

2SD2004 (P)
2SB1328 (P)

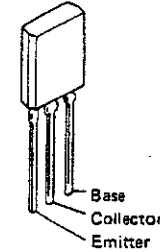

2SD1944
2SB1287

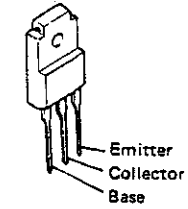

2SD1763A (D)
2SB1186A (D)

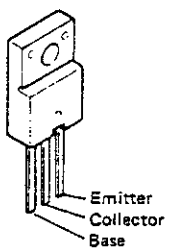

2SA1492LB (O/P/Y)
2SC3856LB (O/P/Y)

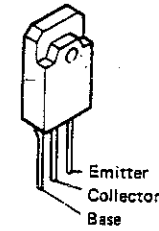

2SA1302 (R/O)
2SC3281 (R/O)

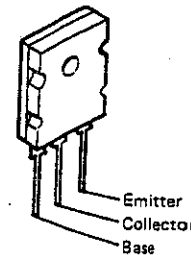

2SK184C (GR)/(BL)

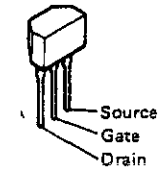

2SK381 (B/C)

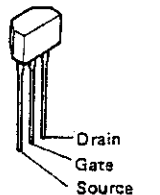

● Diode (included LED)

1S2076A
1SS270A

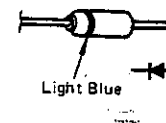

HZ5C-1 HZ18-1
HZ9B-2 HZS2B-1
HZ12A-2 HZS15-2



1SS198

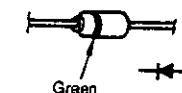

1SS82

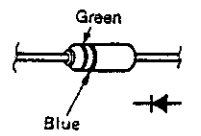

SFOR1A42
Thyristor

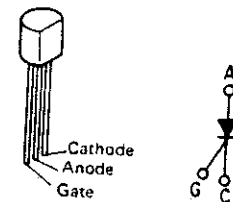

1SR35-200A

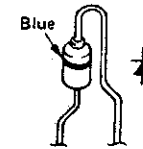

S10VB20F-15

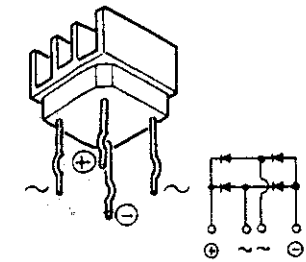

S10VB20

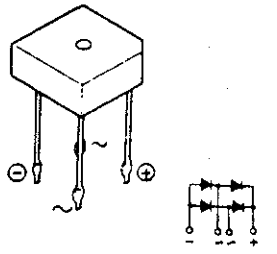

SEL-4117R (Red)
SEL-4917D (Org)

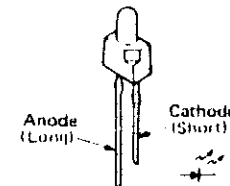

● OTHERS

PTH487A01B0222TS

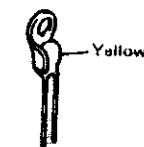

P.W.BOARD OF 1U-2236 POWER AMPLIFIER UNIT

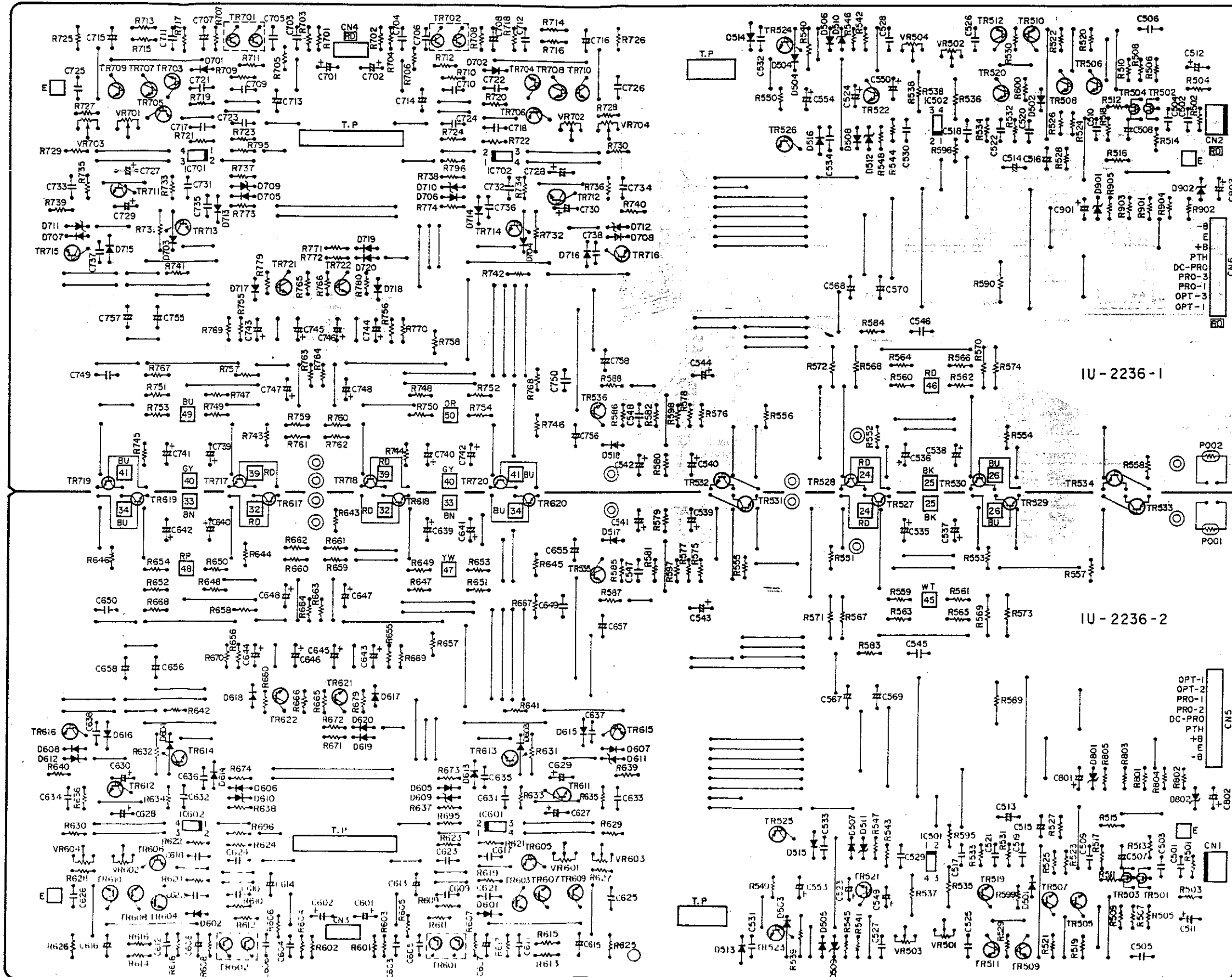

P.W.BOARD OF 1U-2235 INPUT/CONTROL UNIT

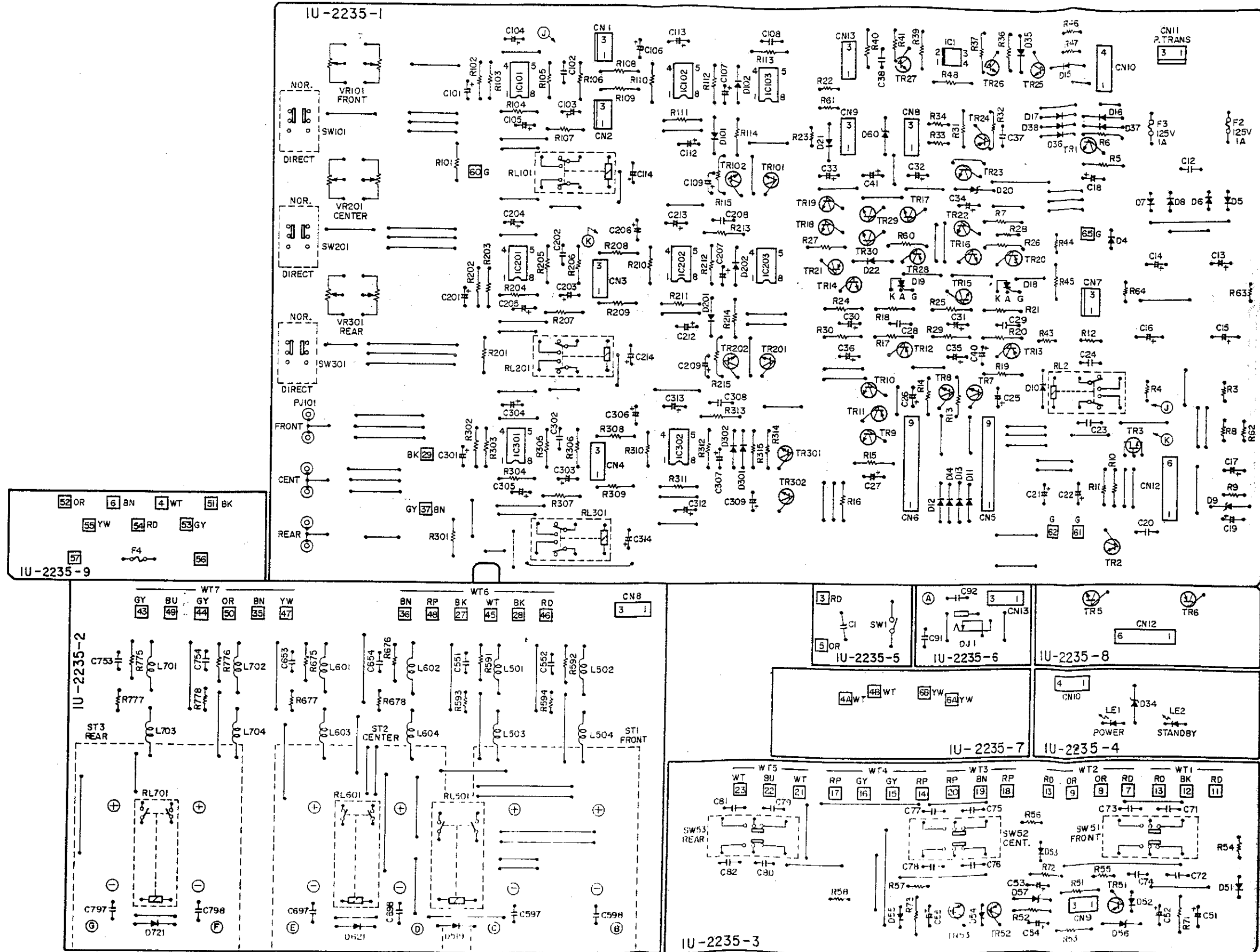

P.W.BOARD OF 1U-2237 POWER SUPPLY UNIT

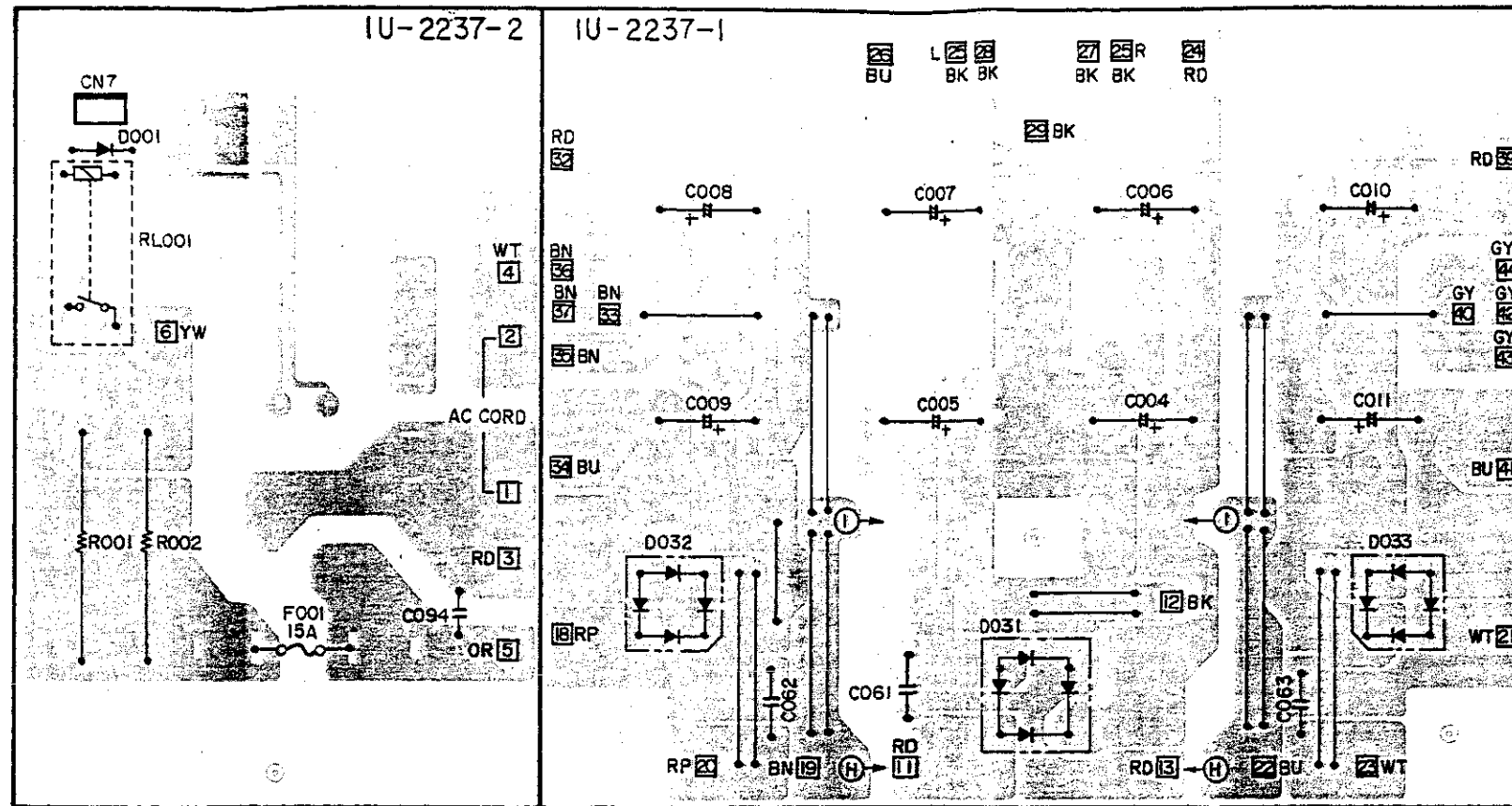

1U-2235 INPUT/CONTROL UNIT

Ref. No.	Part No.	Part Name	Remarks
C725,726	253 4470 900	Ceramic 10pF/500V	CC45SL2H100DT
C727,728	254 4260 948	Electrolytic 1μF/50V	CE04W1H010MT
C729,730	254 4289 039	Electrolytic 100μF/50V	CE04W1H101M(AWF)
C731-734	253 1180 947	Ceramic 0.0015μF/50V	CK45B1H152KT
C735-738	253 4480 903	Ceramic 27pF/500V	CC45SL2H270DT
C739-742	254 4396 906	Electrolytic 100μF/63V	CE04W1J101MT
C743-746	254 4260 993	Electrolytic 22μF/50V	CD041H220MT
C747,748	254 4258 947	Electrolytic 47μF/35V	CE04W1V470MT
C749,750	255 4213 972	Plastic Film 0.01μF/50V	CQ93M1H103JT
C755-758	254 3046 901	Electrolytic(Bipolar) 1μF/100V	CE04D2A010MBPT
C801,802	254 4356 027	Electrolytic 22μF/50V	CE04W1H220M(ARS)
C901,902	254 4356 027	Electrolytic 22μF/50V	CE04W1H220M(ARS)

OTHER PARTS

Ref. No.	Part No.	Part Name	Remarks
P001,022	276 0289 004	Posistor	PTH487A018D222TS
CN001,002	205 0190 036	3P NH Connector Base	
CN003	205 0234 031	3P EH Side Connector Base	
CN004	205 0588 033	3P EH Side Base(Red)	
CN005	205 0233 090	9P EH Connector Base	
CN006	205 0277 098	9P EH Connector Base(Red)	

Ref. No.	Part No.	Part Name	Remarks
SEMICONDUCTORS GROUP			
IC001	252 0847 009	IC Photo Coupler TLP521-1(BL)	
IC101	263 0594 007	IC NJM2068DAC	
IC102	265 0030 004	IC NJM4558D-D	
IC103	263 0654 002	IC NJM2082D	
IC201	263 0594 007	IC NJM2068DAC	
IC202	265 0030 004	IC NJM4558D-D	
IC203	263 0654 002	IC NJM2082D	
IC301	263 0594 007	IC NJM2068DAC	
IC302	265 0030 004	IC NJM4558D-D	

Ref. No.	Part No.	Part Name	Remarks
TR001	273 0253 918	Transistor 2SC2878(A/B)TPE2	
TR002	271 0131 924	Transistor 2SA988T(E/F)	
TR003	275 0048 912	FET 2SK381(B)/(C)T	
TR005	274 0138 007	Transistor 2SD1944	
TR006	272 0119 004	Transistor 2SB1287	
TR007-010	273 0317 906	Transistor 2SC2458(BL)TPE4	
TR011	271 0191 916	Transistor 2SA1048(GR)TPE4	
TR013	273 0235 923	Transistor 2SC1841T(E/F)	
TR014,015	269 0025 901	D.Transistor RN1202(10k-10K)T	
TR016	273 0317 906	Transistor 2SC2458(BL)TPE4	
TR017	269 0025 901	D.Transistor RN1202(10k-10K)T	
TR018	273 0317 906	Transistor 2SC2458(BL)TPE4	
TR019	269 0025 901	D.Transistor RN1202(10k-10K)T	
TR020,021	269 0026 900	D.Transistor RN2202(10k-10K)T	
TR022	274 0111 901	Transistor 2SD1111T	
TR023	273 0235 923	Transistor 2SC1841T(E/F)	
TR024	271 0131 924	Transistor 2SA988T(E/F)	
TR025	274 0060 900	Transistor 2SD667A(C)TZ	
TR026,027	273 0317 906	Transistor 2SC2458(BL)TPE4	
TR028	269 0026 900	D.Transistor RN2202(10k-10K)T	
TR029	269 0025 901	D.Transistor RN1202(10k-10K)T	
TR030	273 0317 906	Transistor 2SC2458(BL)TPE4	
TR051053	269 0026 900	D.Transistor RN2202(10k-10K)T	
TR101	273 0235 923	Transistor 2SC1841T(E/F)	
TR102	269 0067 901	D.Transistor RN1205(2.2K-47K)T	
TR201	273 0235 923	Transistor 2SC1841T(E/F)	
TR202	269 0067 901	D.Transistor RN1205(2.2K-47K)T	
TR301	273 0235 923	Transistor 2SC1841T(E/F)	
TR302	269 0067 901	D.Transistor RN1205(2.2K-47K)T	

Ref. No.	Part No.	Part Name	Remarks
D004-008	276 0348 000	Diode S2K20F	
D009	276 0249 921	Zener Diode HZ18-1TE	
D010-017	276 0049 914	Diode 1S2076A	
D018,019	276 0016 904	Diode SF0R1A42(TPE2)	
D020	276 0318 001	Zener Diode HZ12A-2	
D021,022	276 0049 914	Diode 1S2076A	
D034	276 0218 936	Zener Diode HZ9B2-TE	
D035-038	276 0049 914	Diode 1S2076A	
D051-055	276 0253 905	Diode 1SR35-200A(T93X)	
D056,057	276 0236 934	Zener Diode HZ5C-1TE	
D060	276 0318 001	Zener Diode HZ12A-2	
D101,102	276 0049 914	Diode 1S2076A	
201,202			
301,302			
519,621			
721			

Ref. No.	Part No.	Part Name	Remarks
LE001	393 9420 907	LED SEL4117R-T	(Red)
LE002	393 9420 910	LED SEL4917D-T	(Orange)

RESISTOR GROUP (Not included Carbon Film, ±5% 1/4W type)

Ref. No.	Part No.	Part Name	Remarks
ΔR003,004	241 2387 908	Carbon 1ohm 1/4W (N.B)	RD14B2E010JNBS
ΔR008	244 2052 902	Metal Oxide Film 2.7Kohm 1W (N.B)	RS14B3A272JS
ΔR009	244 2051 990	Metal Oxide Film 4.7Kohm 1W (N.B)	RS14B3A472JS
ΔR012	241 2379 916	Carbon 510ohm 1/4W (N.B)	RD14B2E511JNBS
ΔR022,023	241 2380 905	Carbon 1.2Kohm 1/4W (N.B)	RD14B2E122JNBS
ΔR028	244 2051 974	Metal Oxide Film 1.2Kohm 1W (N.B)	RS14B3A102JS
ΔR033,034	244 2052 931	Metal Oxide Film 390ohm 1W (N.B)	RS14B3A391JS
ΔR043	244 2050 975	Metal Oxide Film 1.3Kohm 1W (N.B)	RS14B3A132JS
ΔR044-047	244 2052 902	Metal Oxide Film 2.7Kohm 1W (N.B)	RS14B3A272JS
ΔR054-058	241 2387 908	Carbon 1ohm 1/4W (N.B)	RD14B2E010JNBS
ΔR061	241 2380 905	Carbon 1.2Kohm 1/4W (N.B)	RD14B2E122JNBS
ΔR062	244 2052 902	Metal Oxide Film 2.7Kohm 1W (N.B)	RS14B3A272JS
ΔR063	244 2051 987	Metal Oxide Film 4.7Kohm 1W (N.B)	RS14B3A472JS
ΔR064	244 2043 937	Metal Oxide Film 10ohm 1W (N.B)	RS14B3A100JS
ΔR534,593	244 2050 904	Metal Oxide Film 22ohm 1W (N.B)	RS14B3A220JS
677,678			
777,778			
VR101,201	211 9106 000	Variable 100Kohm	V1620V30FB104
VR301			

CAPACITORS GROUP

Ref. No.	Part No.	Part Name	Remarks
ΔC001	253 8011 705	Ceramic 0.01μF/250VAC	CK45F2EAC103ZC (Multi-Voltage Models)
C012	255 6167 000	Polystyrene Film 0.01μF/125V	CQ09S2B103K(B)
C013,014	254 4262 784	Electrolytic 470μF/6.3V	CE04W1J471MC
C015,016	254 4397 701	Electrolytic 2200μF/6.3V	CE04W1J222MC
C017	254 4261 921	Electrolytic 100μF/50V	CE04W1H101MT
C018	256 1030 012	Metalized 1μF/100V	CF93W2A105J
C019	254 4291 700	Electrolytic 10μF/100V	CE04W2A100M(AWF)
C020	253 4494 902	Ceramic 100pF/500V	CC45SL2H101JT
C021,022	254 4356 027	Electrolytic 22μF/50V	CE04W1H220M(ARS)
C023,024	253 1151 905	Ceramic 0.0047μF/500V	CK45E2H472PT
C025,026	254 4254 909	Electrolytic 10μF/16V	CE04W1C100MT
C027	254 4250 932	Electrolytic 220μF/6.3V	CE04W0J221MT
C028,029	253 1181 904	Ceramic 0.01μF/50V	CK45F1H103ZT
C030	254 4254 938	Electrolytic 47μF/16V	CE04W1C470MT

Ref. No.	Part No.	Part Name	Remarks
C031	254 4250 932	Electrolytic 220μF/6.3V	CE04W0J221MT
C032,033	254 4256 949	Electrolytic 100μF/25V	CE04W1E101MT
C034	254 1018 009	Tantalum Electrolytic 10μF/16V	CS45E1C100M
C035	254 4254 909	Electrolytic 10μF/16V	CE04W1C100MT
C036	254 4258 905	Electrolytic 4.7μF/35V	CE04W1V47R7MT
C037	253 1151 905	Ceramic 0.0047μF/500V	CK45E2H472PT
C038	253 1181 904	Ceramic 0.01μF/50V	CK45F1H103ZT
C040	254 4258 002	Electrolytic 4.7μF/35V	CE04W1V47R7MT
C041	254 4256 949	Electrolytic 100μF/25V	CE04W1E101MT
C051-055	254 4262 904	Electrolytic 4.7μF/63V	CE04W1J47R7MT
C071	253 1181 904	Ceramic 0.01μF/50V	CK45F1H103ZT
C082	255 4228 996	Ceramic 0.022μF/100V	CQ92PA223JT
C091,092	253 1181 904	Ceramic 0.01μF/50V	CK45F1H103ZT
C101	254 4260 948	Electrolytic 1μF/50V	CE04W1H010MT
C102	255 6163 059	Polystyrene Film 22pF/250V	CQ09S2E220J
C103	254 4254 909	Electrolytic 10μF/16V	CE04W1C100MT
C104-107	254 4260 948	Electrolytic 1μF/50V	CE04W1H010MT
C108	253 1181 904	Ceramic 0.01μF/50V	CK45F1H103ZT
C109	254 4254 909	Electrolytic 10μF/16V	CE04W1C100MT
C112,113	254 4260 948	Electrolytic 1μF/50V	CE04W1H010MT
C114	254 4256 936	Electrolytic 47μF/25V	CE04W1E470MT
C201	254 4260 948	Electrolytic 1μF/50V	CE04W1H010MT
C202	255 6163 059	Polystyrene Film 22pF/250V	CQ09S2E220J
C203	254 4254 909	Electrolytic 10μF/16V	CE04W1C100MT
C204-207	254 4260 948	Electrolytic 1μF/50V	CE04W1H010MT
C208	253 1181 904	Ceramic 0.01μF/50V	CK45F1H103ZT
C209	254 4254 909	Electrolytic 10μF/16V	CE04W1C100MT
C212,213	254 4260 948	Electrolytic 1μF/50V	CE04W1H010MT
C214	254 4256 936	Electrolytic 47μF/25V	CE04W1E470MT
C301	254 4260 948	Electrolytic 1μF/50V	CE04W1H010MT
C302	255 6163 059	Polystyrene Film 22pF/250V	CQ09S2E220J
C303	255 4254 909	Electrolytic 10μF/16V	CE04W1C100MT
C304-307	254 4260 948	Electrolytic 1μF/50V	CE04W1H010MT
C308	253 1181 904	Ceramic 0.01μF/50V	CK45F1H103ZT
C309	254 4254 909	Electrolytic 10μF/16V	CE04W1C100MT
C312,313	254 4260 948	Electrolytic 1μF/50V	CE04W1H010MT
C314	254 4256 936	Electrolytic 47μF/25V	CE04W1E470MT
C551,552	255 4228 996	Ceramic 0.022μF/100V	CQ92PA223JT
653,654			
753,754			

OTHER PARTS

Ref. No.	Part No.	Part Name	Remarks
L501-504	235 0068 004	Inductor	1mH
601-604			
701-704			
RL002	214 9013 008	Relay	BS-RH-12S UL
RL101,201	214 0143 003	Relay	RY-24W
301			
RL501	214 0037 009	Relay	JC-48V
RL601,701	214 0129 001	Relay	DH2TU
ΔF002,003	206 1039 034	Fuse 1.0A	U.S.A. Models
ΔF002,003	206 1053 007	Fuse 1.0A	Multi-Voltage Models
ΔSW001	212 9534 002	Power Switch	(PUSH)TV-8
SW051-053	212 2605 006	Slide Switch	
SW101,201	212 3644 008	Slide Switch	
301			

1U-2237 POWER SUPPLY UNIT

Ref. No.	Part No.	Part Name	Remarks	Ref. No.	Part No.	Part Name	Remarks
DJ001	204 8101 008	2P Power Jack	INPUT(GOLD)	D001	276 0049 011	Diode 1S2076A	
PJ101	204 8288 002	6P Connector Base		D031	276 0579 002	Diode S10VB20F-15	
ST001-003	205 0671 005	4P Terminal		D032,033	276 0586 008	Diode S10VB20	
WT001,003,005	205 0075 038	3P Terminal		R001,002	243 2079 021	Wire Wound Resistor(Cement) 33ohm/10W	RW78A4A330K=(UL)
WT002,004	205 0075 041	Wrapping Terminal		C004,005	254 4370 715	Electrolytic Capacitor 8200µF/63V	CE04W1J822MC(DL)
WT006,007	205 0075 067	6P Wrapping Terminal		C006,007	254 4412 000	Electrolytic Capacitor 8200µF/63V	CE04W1J822MC(ARS)
CN001,002	205 0190 036	3P NH Connector Base		C008-011	254 4365 720	Electrolytic Capacitor 12000µF/56V	CE04W==123MC(DL)
CN003	205 0233 032	3P EH Connector Base		C061-063	256 1043 711	Metalized Capacitor 0.47µF/250V	CF93B2E474K
CN004	205 0277 030	3P EH Connector Base(Red)		△C093	253 8011 006	Ceramic Capacitor 0.01µF/250VAC	CK45F2EAC103Z
CN005	205 0233 090	9P EH Connector Base		C094,095	255 6167 000	Polystyrene Film Capacitor 1µF/125V	CQ09S2B105K(B)
CN006	205 0277 098	9P EH Connector Base(Red)		RL001	214 0117 000	Relay (VS48MBUL TV5)	
CN007	205 0190 036	3P NH Connector Base		CN007	205 0190 036	3P NH Connector Base	
CN008	205 0587 034	3P EH Slide Base(Blk)		△F001	206 1051 030	Fuse 15A	U.S.A. Models
CN008	205 0278 039	3P EH Connector Base(Blk)	△F001	206 1017 030	Fuse 15A	Multi-Voltage Models	
CN009	205 0296 037	3P EH Connector Base(Yel)					
CN010	205 0234 044	4P EH Slide Connector Base					
CN010	205 0233 045	4P EH Connector Base					
CN011	205 0190 036	3P NH Connector Base					
CN012	204 0339 001	6P EH-SCN Connector Cord					
CN012	205 0233 061	6P EH Connector Base					
CN013	205 0276 031	3P EH Connector Base(Blu)					

PARTS LIST OF EXPLODED VIEW

Ref. No.	Part No.	Part Name	Remarks
⊙ 1	412 9294 007	SWITCH COVER	
⊙ 2	102 9036 106	TOP COVER	(Gold)
⊙ 2	102 9036 122	TOP COVER	(Black)
⊙ 3	461 9025 032	RUBBER SHEET	
⊙ 4	122 0095 001	SPACER	
⊙ 5	122 9006 017	SPACER	
⊙ 6	461 9012 016	CUSHION	
⊙ 7	112 0555 007	VOLUME KNOB(B)	
⊙ 8	113 9242 107	PUSH KNOB(P) ASS'Y	(Gold)
⊙ 8	113 9242 110	PUSH KNOB(P) ASS'Y	(Black)
⊙ 9	144 9138 008	FRONT PANEL ASS'Y	(Gold)
⊙ 9	144 9138 215	FRONT PANEL ASS'Y	(Black)
⊙ 10	144 9137 106	SIDE ESC. BAR	(Gold)
⊙ 10	144 9137 119	SIDE ESC. BAR	(Black)
⊙ 11	412 9292 009	ESC. BRACKET	
⊙ 12	412 9293 008	ESC. SUPPORTER	
13	477 0096 007	PUSH RIVET	
⊙ 14	412 9295 006	HEAT SINK SUPPORTER	
⊙ 15	461 0390 070	RUBBER SHEET	
⊙ 16	415 9061 006	INSULATING COVER	
⊙ 17	125 9004 047	UL TUBE	
⊙ 18	233 9645 008	POWER TRANSFORMER	U.S.A. Models
⊙ 18	233 9643 000	POWER TRANSFORMER	Multi-Voltage Models
⊙ 19	445 0048 016	CORD HOLDER	L50
⊙ 20	443 0900 129	P.W.B. SUPPORTER	
⊙ 21	412 9274 014	P.W.B. BRACKET	
⊙ 22	412 9288 107	HEAT SINK BRACKET(REAR)	
⊙ 23	412 9291 107	HEAT SINK BRACKET(LEFT)	
⊙ 24	412 9290 108	HEAT SINK BRACKET(RIGHT)	
⊙ 25	417 9062 001	CU PLATE	
⊙ 26	417 9061 109	HEAT SINK	
27	415 0234 007	INSULATING SHEET	
28	415 9059 005	INSULATING SHEET	
29	273 0355 077	TRANSISTOR 2SC3856LB	
30	271 0221 009	TRANSISTOR 2SA1492LB	
31	273 0391 003	TRANSISTOR 2SC3291	
32	271 0245 001	TRANSISTOR 2SA1302	
⊙ 33	417 9063 000	HEAT SINK	
⊙ 34	412 9289 106	LEVEL VOLUME BRACKET	
⊙ 35	461 0114 023	CUSHION	
⊙ 36	415 9016 019	P.C.B. HOLDER	
⊙ 37	443 9015 002	P.W. SPACER	
38	104 9026 202	FOOT	
⊙ 39	412 9081 207	SUPPORT BRACKET	
⊙ 40	105 9185 108	BOTTOM COVER	
⊙ 41	414 9117 009	SAFETY SHEET	
⊙ 42	445 0071 009	CORD BUSH	
⊙ 43	206 2060 002	AC CORD(POLARIZED)	U.S.A. Models
⊙ 43	206 2083 005	AC CORD WITH PLUG	Multi-Voltage Models
⊙ 44	415 9032 006	P.C.B. HOLDER(T)	
⊙ 45	412 9287 108	CHEM. CON. BRACKET	
⊙ 46	105 9208 108	REAR PANEL	U.S.A. Models
⊙ 46	105 9205 101	REAR PANEL	Multi-Voltage Models
⊙ 47	411 9099 102	SHIELD CHASSIS	
⊙ 48	411 9098 103	TRANS. CHASSIS	
⊙ 49	411 9097 104	FRONT CHASSIS	
⊙ 50	412 9296 005	BRACKET(A)	
51	393 9420 907	LED(RED)	SEL4117R-T(LE1)
52	393 9420 910	LED(ORG)	SEL4917D-T(LE2)
53	272 0119 004	TRANSISTOR 2SB1287	
54	274 0138 007	TRANSISTOR 2SD1944	
55	212 9534 002	POWER SWITCH	
56	212 2605 006	SLIDE SWITCH	
57	211 9106 000	VARIABLE RESISTOR	V1620V30FB104
58	212 3844 008	SLIDE SWITCH	
59	204 8288 002	6P CONNECTOR BASE	
⚠ 60	206 1039 034	Fuse 1.0A	U.S.A. Models
⚠ 60	206 1053 007	Fuse 1.0A	Multi-Voltage Models
61	214 9013 008	RELAY	BSR-H-12S UL
62	214 0143 003	RELAY	RY-24W
63	204 8101 008	2P POWER JACK	
64	205 0671 005	4P TERMINAL	
65	243 2079 021	WINDING RESISTOR	RW78A330K=(UL)
66	214 0117 000	RELAY	VS48MBUL TV-5
⚠ 67	206 1051 012	Fuse 15A	U.S.A. Models
⚠ 67	206 1017 030	Fuse 15A	Multi-Voltage Models
68	276 0424 005	DIODE	4D4B42(LC1)
69	276 0356 005	DIODE	DSFB20(4001)
⊙ 70	445 0048 003	CORD HOLDER	L=76
⊙ 71	415 9018 017	INSULATING SHEET	t0.3
⊙ 72	461 0390 012	RUBBER SHEET	t2
⊙ 73	461 9029 009	SPACER	t0.5
⚠ 80	212 3634 005	VOLTAGE SELECTOR	Multi-Voltage Models Only
⊙ 81	412 9304 007	VOLTAGE SELECTOR BRACKET	Multi-Voltage Models Only
⊙ 201	1U-2235E	INPUT/CONTROL UNIT	U.S.A. Models
⊙ 201	1U-2235D	INPUT/CONTROL UNIT	Multi-Voltage Models
⊙ 202	1U-2236E	POWER AMPLIFIER UNIT	U.S.A. Models
⊙ 202	1U-2236D	POWER AMPLIFIER UNIT	Multi-Voltage Models
⊙ 203	1U-2236D	POWER SUPPLY UNIT	U.S.A. Models
⊙ 203	1U-2237D	POWER SUPPLY UNIT	Multi-Voltage Models
101	473 7017 016	SCREW 3x8	CBTS(S)-C
102	473 7002 005	SCREW 3x6	CBTS(S)-Z
103	473 7002 021	SCREW 3x8	CBTS(S)-B
100	473 7015 018	SCREW 3x8	CBTS(S)-B
105	477 0064 107	SCREW 3x10	
106	473 7508 017	SCREW 3x10	CBTS(P)-B
107	473 7501 014	SCREW 3x14	CBTS(P)-Z
108	473 8007 025	3x8 SCREW WITH WASHER	
109	473 8007 009	3x12 SCREW WITH WASHER	
110	473 8007 038	3x14 SCREW WITH WASHER	
111	471 1302 019	3x5 SCREW	
112	473 0263 005	3POINT SWELLING SCREW	
113	477 0263 018	3POINT SWELLING SCREW	(Gold)
113	477 0263 005	3POINT SWELLING SCREW	(Black)
114	477 0262 006	SPECIAL SCREW	
115	475 3009 008	SPECIAL WASHER (φ7)	
116		SPECIAL NUT (φ7)	
117	473 7002 034	SCREW 3x6	CBTS(S)-B

PARTS LIST OF PACKING & ACCESSORIES

Ref. No.	Part No.	Part Name	Remarks	Q'ty
⊙	504 7102 003	STYRENE PAPER (800x650)		1
⊙	504 7102 032	STYRENE PAPER (350x250)	FOR AC CORD	1
	505 0075 051	CABINET COVER		1
	505 8023 076	ENVELOPE	For Accessories	1
	503 9219 100	CUSHION (L)		1
	503 9220 102	CUSHION (R)		1
	502 9122 003	CUSHION (REAR)		1
	501 9191 031	CARTON CASE		1
	203 2247 004	REMOTE PLUG CORD		1
	511 9315 005	INST. MANUAL		1
	513 9160 007	NOTICE SHEET		1
	513 9111 001	COLOR LABEL (Gold)	(Gold)	1

WARNING:

- Parts marked with " ⚠ " and/or shading have special characteristics important to safety.
Be sure to use the specified parts for replacement.
- Part indicated with the mark " ⊙ " are not always in stock and possibly to take a long period of time for supplying, or in some case supplying of part may be refused.
- (Black) in the remarks column refers models with black front panels,
(Gold) to models with gold front panels.

EXPLODED VIEW

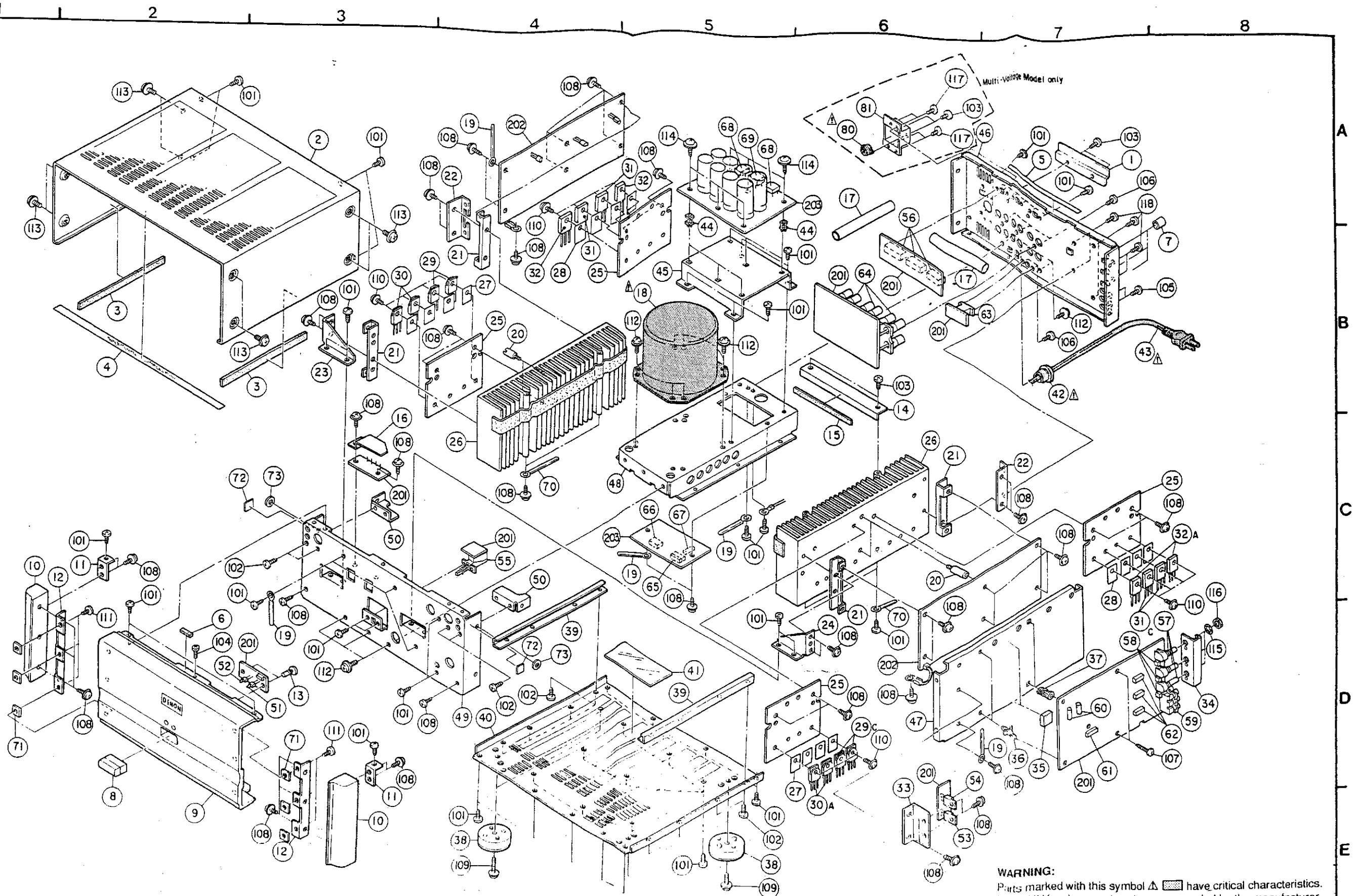

WARNING:
Parts marked with this symbol  have critical characteristics.
Use ONLY replacement parts recommended by the manufacturer.

WIRING DIAGRAM

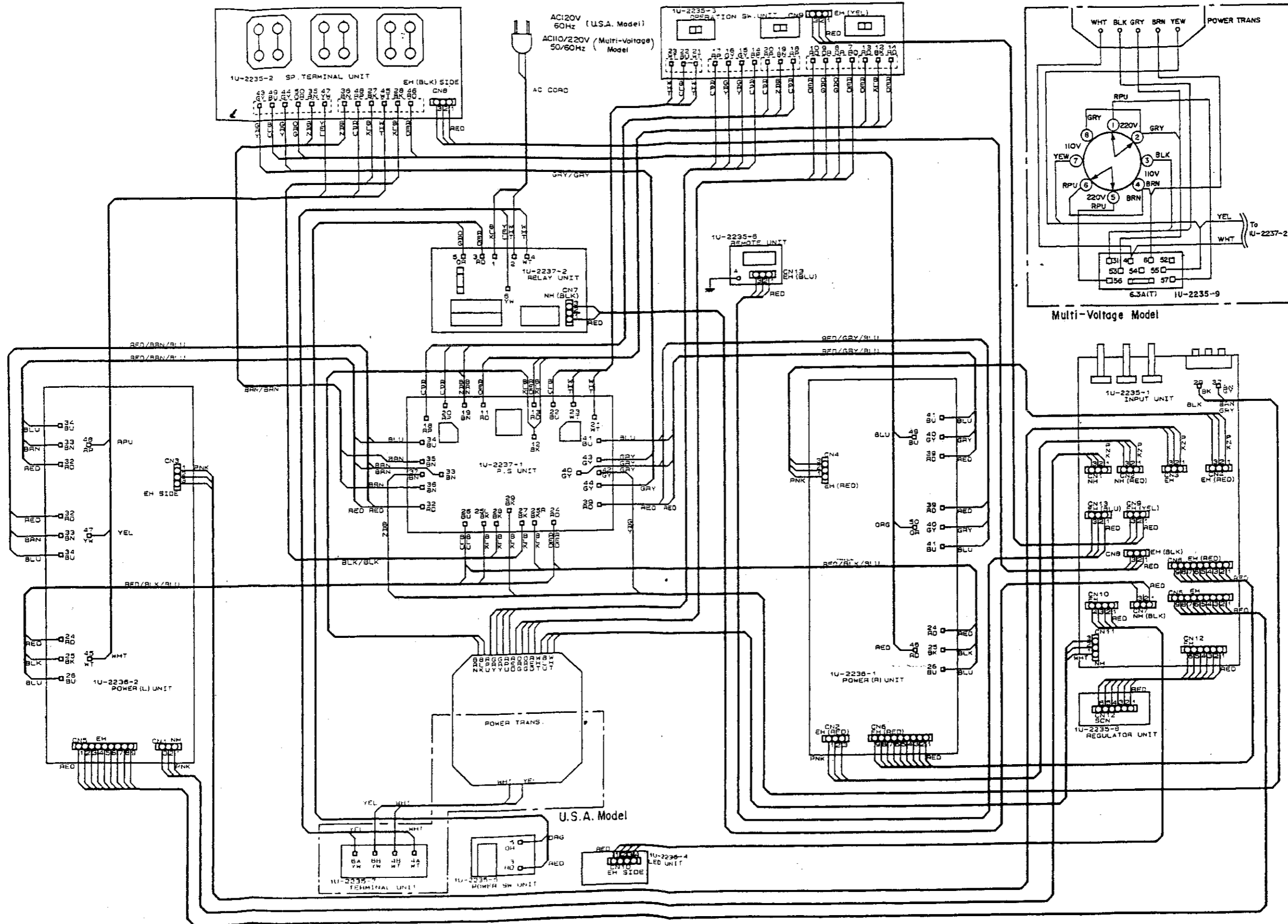

SCHEMATIC DIAGRAM

1 2 3 4 5 6

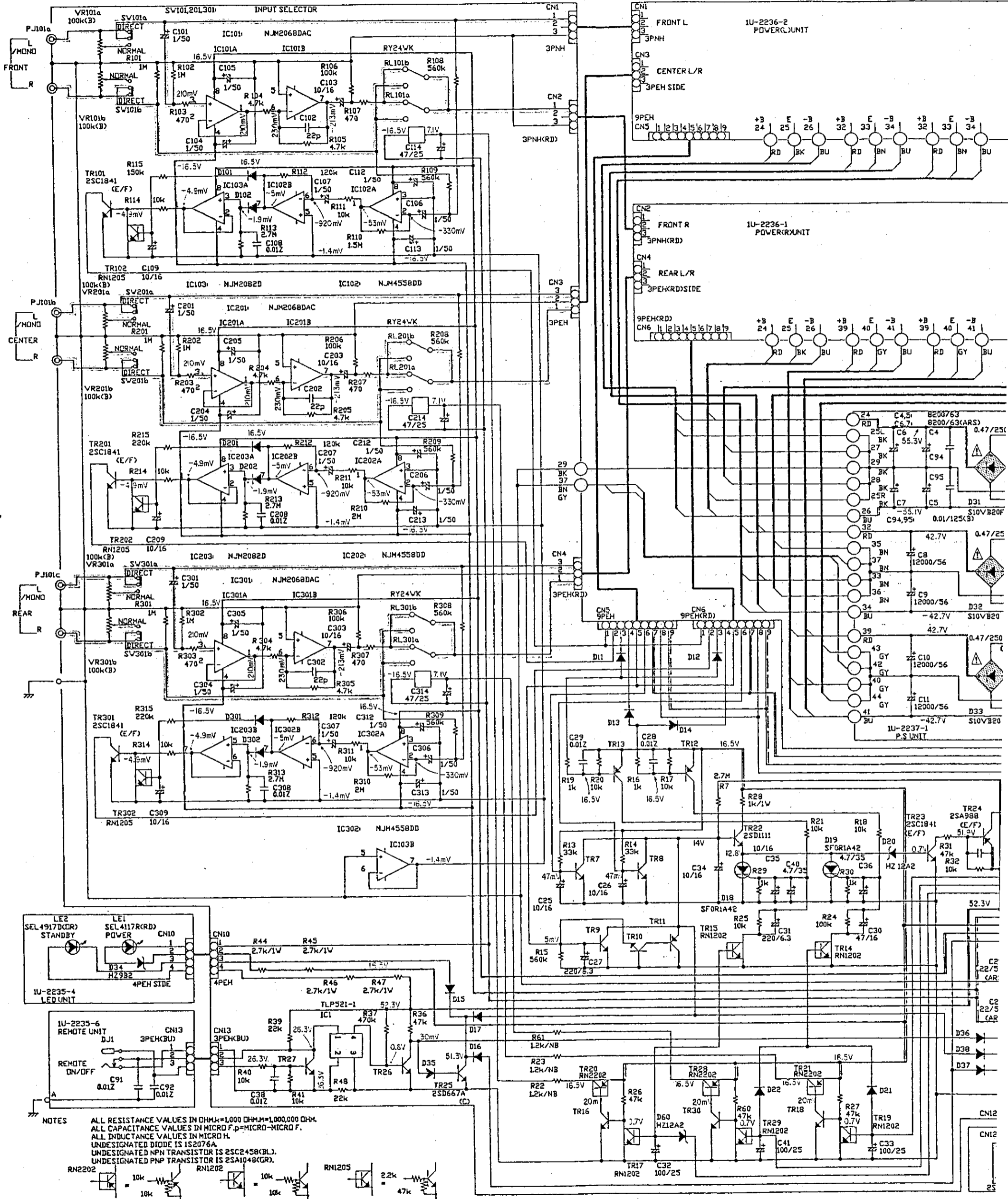

NOTES
 ALL RESISTANCE VALUES IN OHM. K=1,000 OHM. M=1,000,000 OHM.
 ALL CAPACITANCE VALUES IN MICRO F. P=MICRO-MICRO F.
 ALL INDUCTANCE VALUES IN MICRO H.
 UNDESIGNATED DIODE IS 1S2076A.
 UNDESIGNATED NPN TRANSISTOR IS 2SC2458(BL).
 UNDESIGNATED PNP TRANSISTOR IS 2SA1048(GR).



NOTES
 ALL RESISTANCE VALUES IN OHM. K
 ALL CAPACITANCE VALUES IN MICRO
 EACH VOLTAGE AND CURRENT ARE
 CIRCUIT AND PARTS ARE SUBJECT

7

8

9

10

11

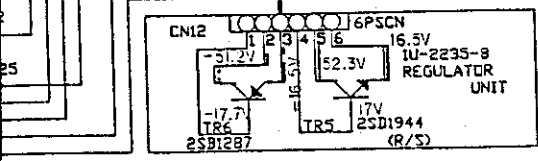
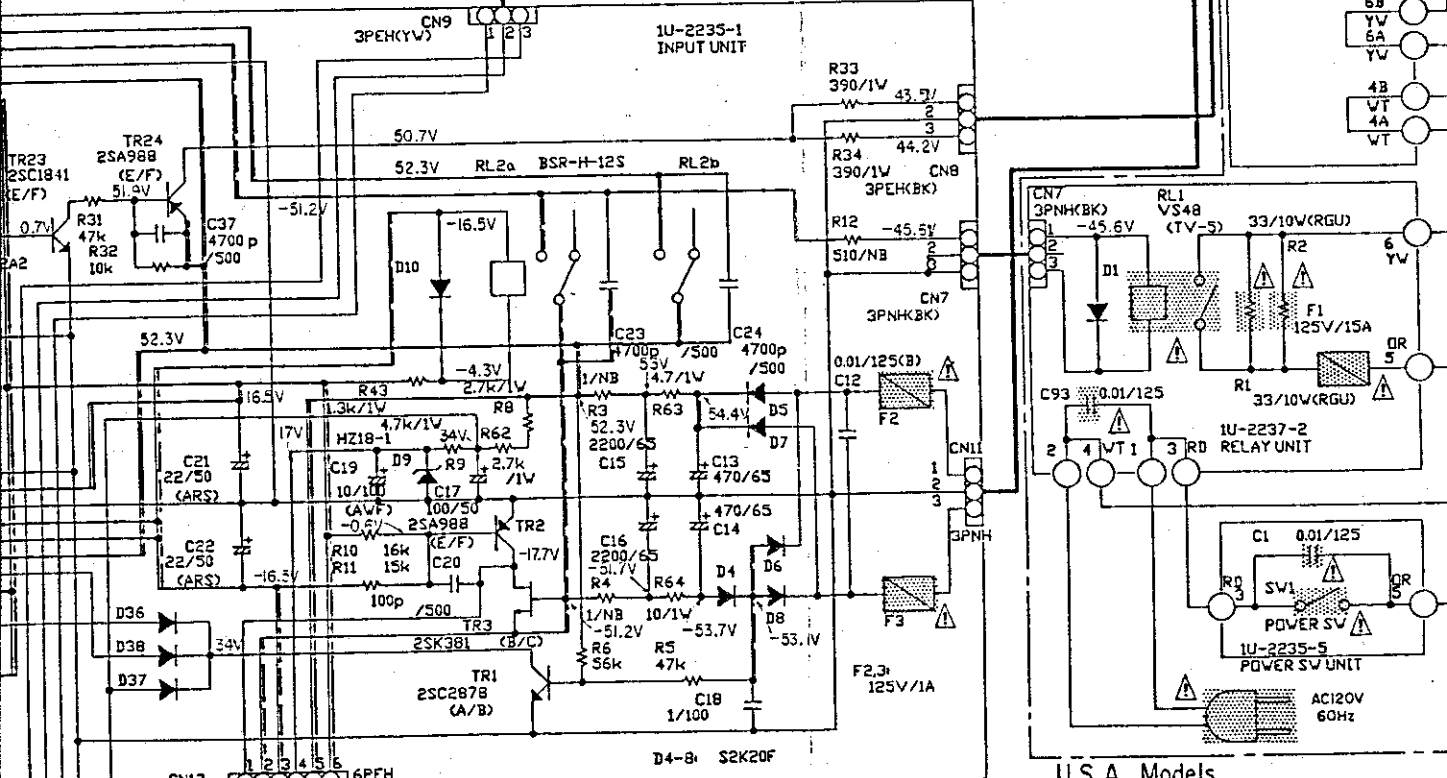
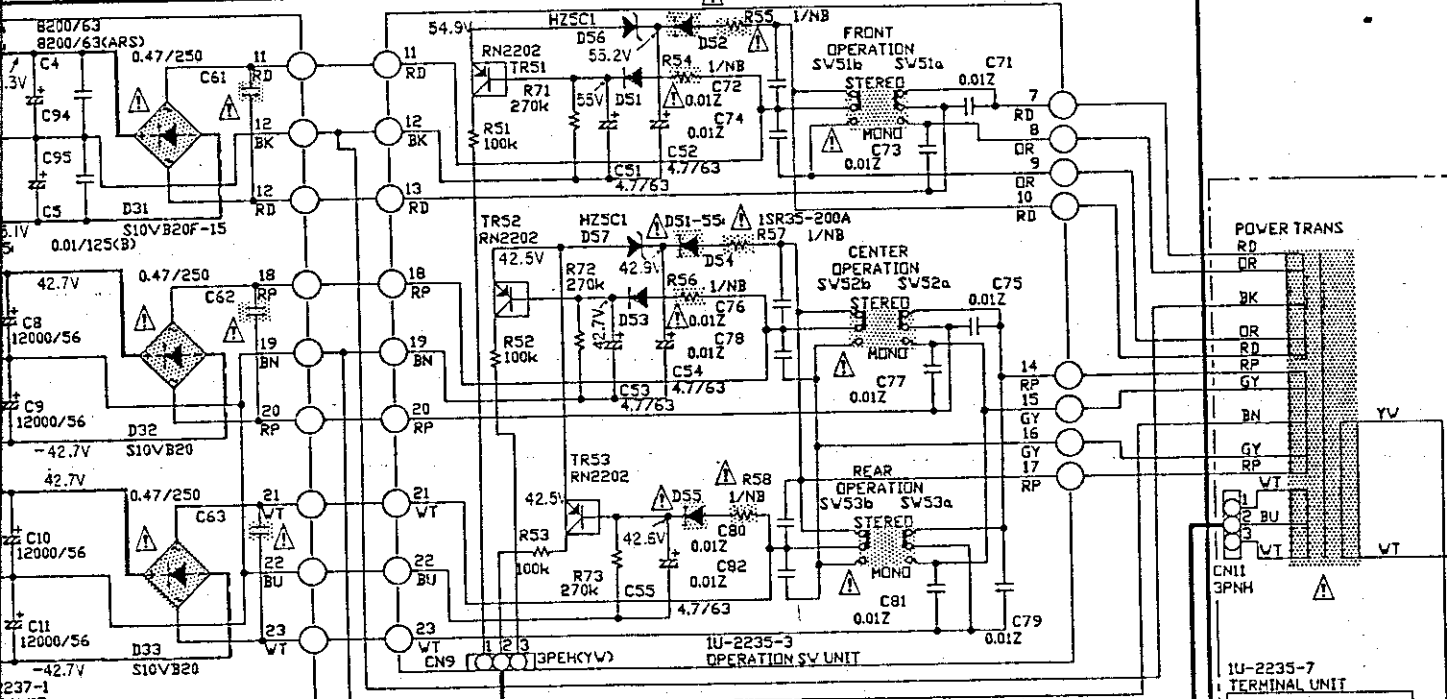
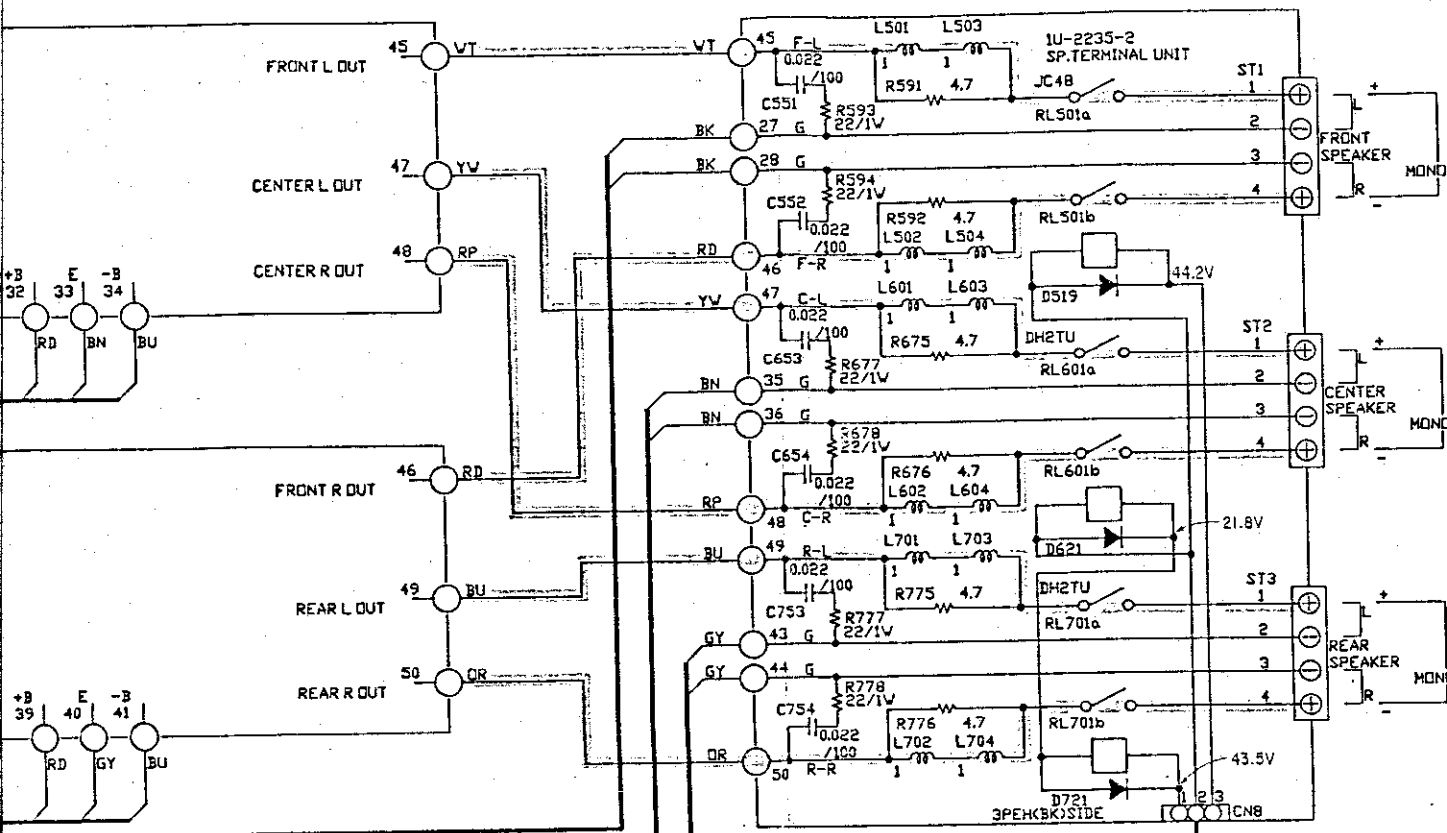

— +B LINE
 - - - -B LINE
 ——— SIGNAL LINE

RESISTOR VALUES IN OHM, K=1,000 OHM, M=1,000,000 OHM
 CAPACITOR VALUES IN MICRO FARAD, P=MICRO-MICRO FARAD
 VOLTAGE AND CURRENT ARE MEASURED AT NO SIGNAL INPUT CONDITION.
 PARTS ARE SUBJECT TO CHANGE WITHOUT PRIOR NOTICE.

WARNING:
 Parts marked with this symbol Δ have critical characteristics.
 Use ONLY replacement parts recommended by the manufacturer.

CAUTION:
 Before returning the unit to the customer, make sure you make either (1) a leakage current check or (2) a line to chassis resistance check. If the leakage current exceeds 0.5 millamps, or if the resistance from chassis to either side of the power cord is less than 240 kohms, the unit is defective.

WARNING:
 DO NOT return the unit to the customer until the problem is located and corrected.

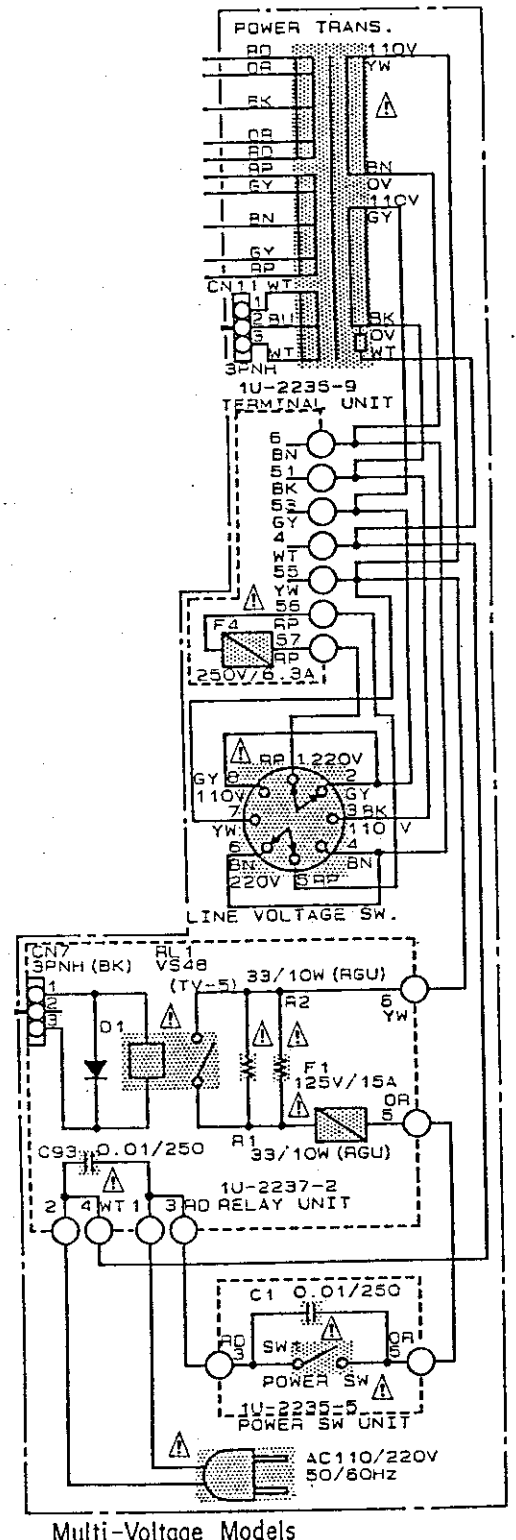

Multi-Voltage Models

U.S.A. Models

A
B
C
D
E
F
G
H

SCHEMATIC DIAGRAM

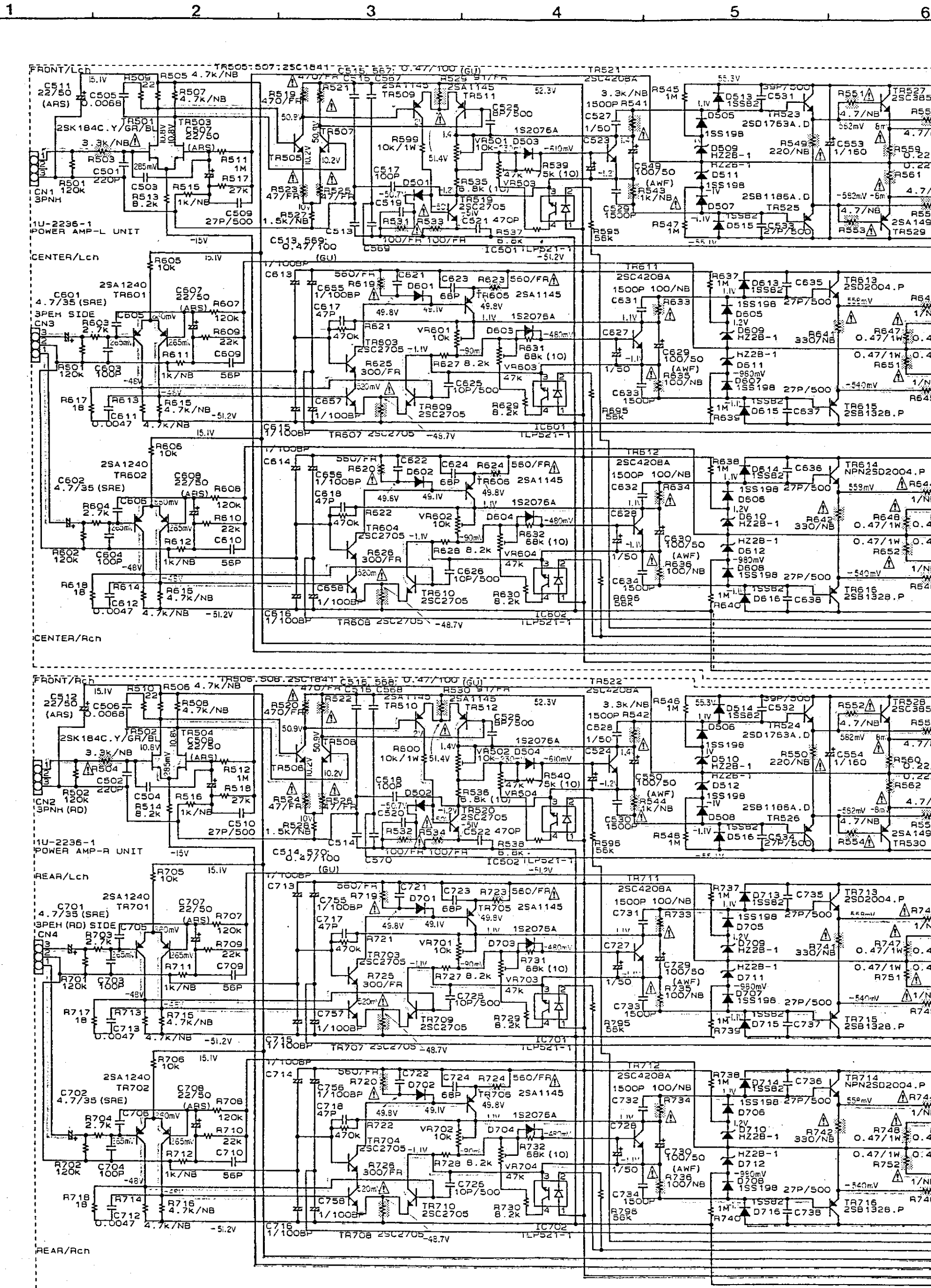

NOTES

ALL RESISTANCE VALUES IN OHM, k=1,000 OHM, M=1,000,000 OHM
 ALL CAPACITANCE VALUES IN MICRO FARAD, P=MICRO-MICRO FARAD
 EACH VOLTAGE AND CURRENT ARE MEASURED AT NO SIGNAL INPUT CONDITION.
 CIRCUIT AND PARTS ARE SUBJECT TO CHANGE WITHOUT PRIOR NOTICE.

WARNING:

Parts marked with this symbol Δ have critical characteristics.
 Use ONLY replacement parts recommended by the manufacturer.

CAUTION:

Before returning the unit to the customer, make sure you make either (1) a leakage current check or (2) a line to chassis resistance check. If the leakage current exceeds 0.5 milliamps, or if the resistance from chassis to either side of the power cord is less than 240 ohms, the unit is defective.

WARNING:

DO NOT return the unit to the customer until the problem is located and corrected.

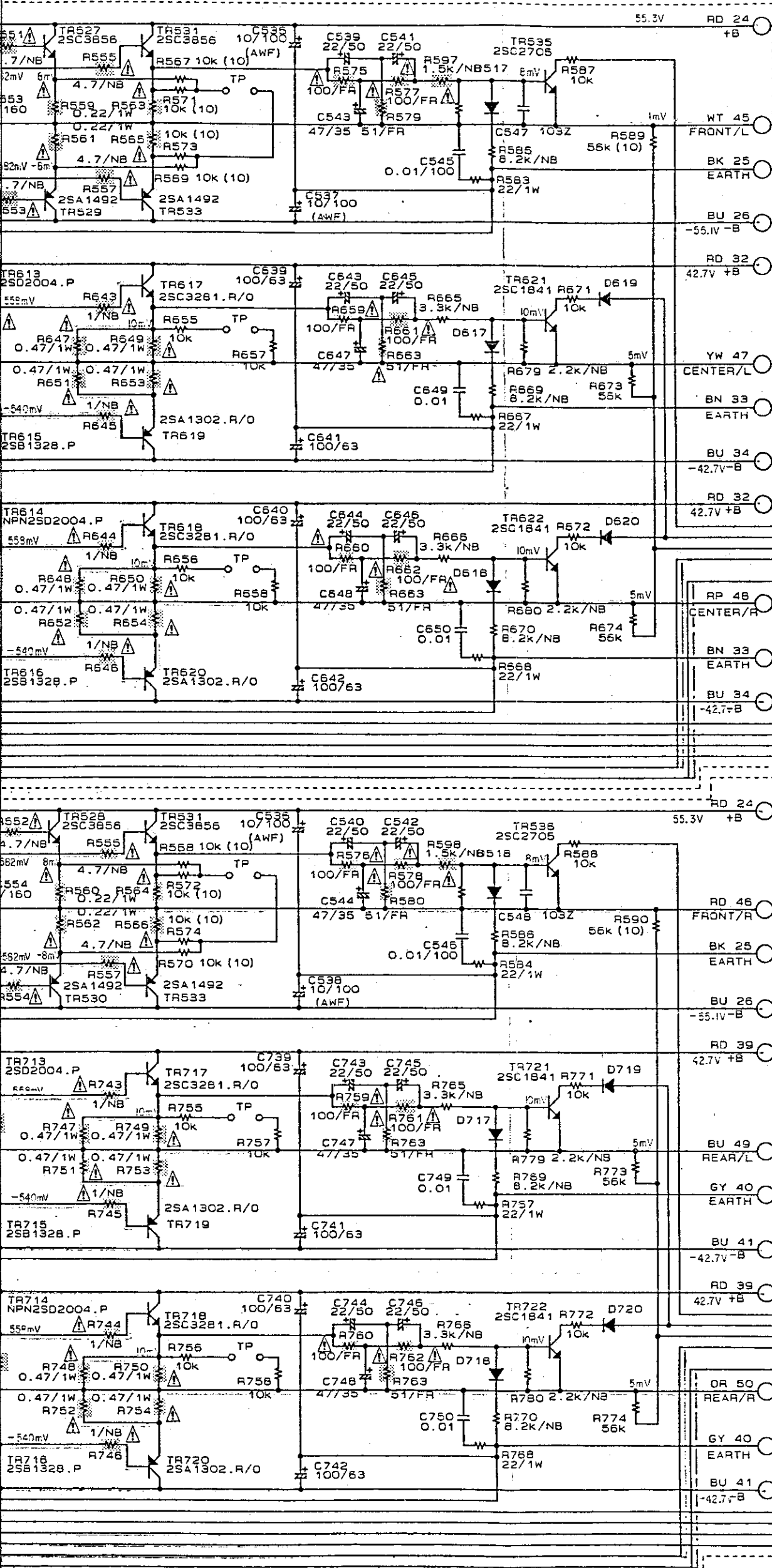

(NOTES)
 ALL RESISTANCE VALUES IN OHM.
 K=1,000 OHM, M=1,000,000 OHM.
 ALL CAPACITANCE VALUES IN MICRO F.
 P=MICRO-MICRO F.
 UNDESIGNATED DIODE IS 1SS270A.
 UNDESIGNATED RESISTOR IS RD14B2E (P=5)

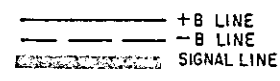

2) a line to chassis resistance check. If cord is less than 240 kohms, the unit is