

DENON

Hi-Fi Stereo Power Amplifier

SERVICE MANUAL MODEL POA-2400

SOLID STATE
STEREO POWER AMPLIFIER

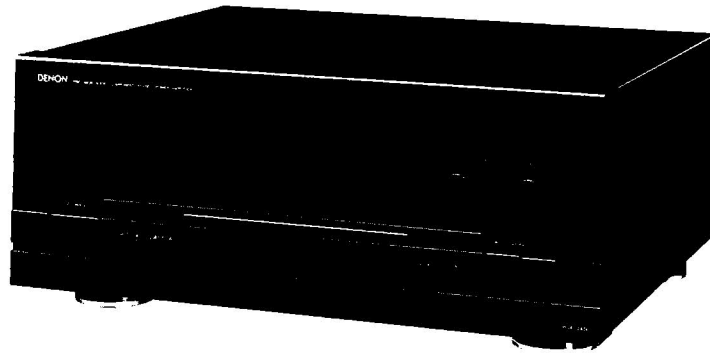

CONTENTS

SPECIFICATIONS	2
NAMES OF PARTS	3
CONNECTIONS	4
REMOVAL OF EACH SECTION	5
METHOD OF ADJUSTMENTS	6
ALIGNMENT POINTS	7
TROUBLESHOOTING	8
BLOCK LEVEL DIAGRAM	9
SEMICONDUCTORS	9
PRINTED WIRING BOARD PATTERNS	
KU9143 POWER UNIT	10
ETC9071E SUPPLY UNIT	11
PRINTED WIRING BOARD PARTS LIST	12, 13
WIRING DIAGRAM	14
SCHEMATIC DIAGRAM	15
EXPLODED VIEW OF CHASSIS AND CABINET & PARTS LIST	16
ADDENDUM LIST	17

NIPPON COLUMBIA CO., LTD.

SPECIFICATIONS

Rated output power: (both channels driven) 200W per channel min, RMS with both channels driven into 8 ohms from 20 Hz to 20 kHz with no more than 0.01% total harmonic distortion (U.S.A.)
 200 W + 200 W (8 ohms, 20 Hz – 20 kHz)
 330 W + 330 W (4 ohms, DIN 1 kHz)
Dynamic Power: 450 W + 450 W (at 4 ohms)
 620 W + 620 W (at 2 ohms)
Total harmonic distortion: Less than 0.002% (–3 dB at rated output, 8 ohms)
Intermodulation distortion: Less than 0.002% (80 Hz/7 kHz: 4/1 at rated output, 8 ohms)
Power band width: 5 Hz – 80 kHz (8 ohms, THD 0.03%)
Frequency response:
 • Europe, Australia and U.K. Models. 1 Hz – 300 kHz $\pm 0_{-3}$ dB (at 1 W) (DIRECT)
 1 Hz – 100 kHz $\pm 0_{-3}$ dB (at 1 W) (NORMAL)
 • U.S.A., Canada and Multiple Models. 1 Hz – 300 kHz $\pm 0_{-3}$ dB (at 1 W)
Input sensitivity: 1V (NORMAL, DIRECT)
Input impedance:
 • Europe, Australia and U.K. Models. 25k ohms (NORMAL in / DIRECT in)
 • U.S.A., Canada and Multiple Models. 25k ohms (NORMAL in)
 47k ohms (DIRECT in)
Output impedance: 0.1 ohm (1 kHz)

S/N ratio: 123 dB (A-weighting)
Output terminals speakers:
 • Europe, Australia and U.K. Models. A or B: 4 – 16 ohms
 A + B: 8 – 16 ohms
 • U.S.A., Canada and Multiple Models. A or B: 6 – 16 ohms
 A + B: 12 – 16 ohms
General
Self diagnostic function: Display lights
Power supply: Europe AC 220 V/50 Hz
 U.K. and Australia AC 240 V/50 Hz
 U.S.A. and Canada AC 120 V/60 Hz
 Asia AC 110/120/220/240 V 50/60 Hz (Multiple)
Power consumption: 7.5A (U.S.A. and Canada)
 500 W (IEC)
 350 W (Multiple)
Dimensions: 434 mm (17-3/32") W x 187 mm (7-23/64") H x 429 mm (16-7/8) D (Including control knobs and feet)
Weight: 17.5 kg (38 lbs 10 oz)

Design and specifications are subject to change without prior notice.

This Service Manual is prepared based on U.S.A. Black Version.

For United Kingdom model only.

WARNING:

As the colours of the wires in the mains lead of this appliance may not correspond with the coloured markings identifying the terminals in your plug proceed as follows:

The wire which is coloured blue must be connected to the terminal which is marked with the letter N or coloured black.
 The wire which is coloured brown must be connected to the terminal which is marked with the letter L or coloured red.

The wire which is coloured BROWN must be connected to the terminal which is marked with the letter L or coloured RED.

IMPORTANT

The wires in this mains lead are coloured in accordance with the following code:

Blue: Neutral
 Brown: Live

For U.S.A. and Canada models.

CAUTION

TO PREVENT ELECTRIC SHOCK DO NOT USE THIS (POLARIZED) PLUG WITH AN EXTENSION CORD, RECEPTACLE OR OTHER OUTLET UNLESS THE BLADES CAN BE FULLY INSERTED TO PREVENT BLADE EXPOSURE.

• **LINE VOLTAGE (Voltage select switch) . . . For Multiple voltage model only.**

- * The desired voltage may be set with the VOLTAGE SELECTOR KNOB on the back panel using a screw driver.
- * Do not twist the VOLTAGE SELECTOR KNOB with excessive force. It may be damaged.
- * If the voltage select switch does not turn smoothly, see a qualified serviceman.

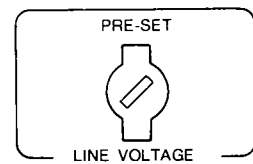

NAMES OF PARTS

• FRONT PANEL

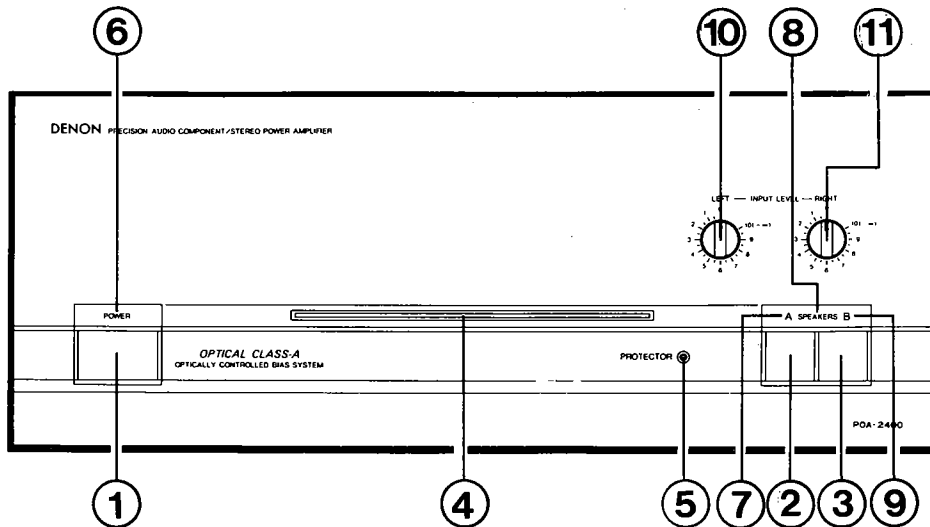

Fig. 1

- | | |
|--|---|
| <p>① POWER (Power Switch)</p> <p>② SPEAKERS-A (Speaker Select Switch-A)</p> <p>③ SPEAKERS-B (Speaker Select Switch-B)</p> <p>④ SELF-DIAGNOSIS (Self-diagnostic Result Indicator Lamps)</p> <p>* ⑤ PROTECTOR (Protection Button)</p> <ul style="list-style-type: none"> • The amplifier incorporates a speaker impedance protection circuit. If this circuit is triggered, it can be released by pressing this button. • The speakers-A or speakers-B indicator may flash when using speakers with extremely low impedance ratings. If this happens, adjust the volume level until the indicators stop flashing and to obtain better sound quality. | <p>⑥ POWER (Power Indicator)</p> <p>⑦ "A" (Speaker "A" Indicator)</p> <p>⑧ SPEAKERS (Speaker Function Indicator)</p> <p>⑨ "B" (Speaker "B" Indicator)</p> <p>⑩ INPUT LEVEL (Lch Input Level Control)</p> <p>⑪ INPUT LEVEL (Rch Input Level Control)</p> |
|--|---|

• BACK PANEL

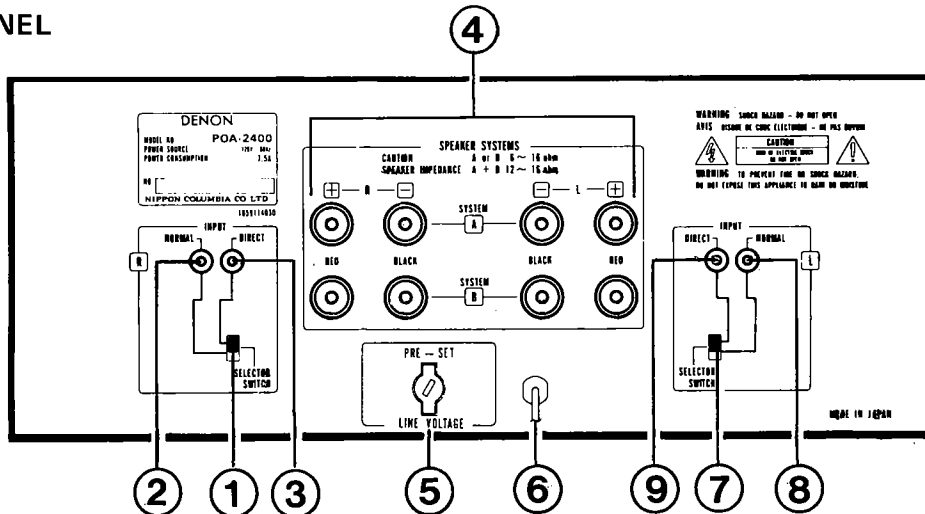

Fig. 2

- | | |
|--|---|
| <p>① INPUT SELECTOR SW (Rch.)</p> <p>② NORMAL (Rch. Normal Input Jack)</p> <p>③ DIRECT (Rch. Direct Input Jack)</p> <p>④ SPEAKER SYSTEMS (Speaker Terminals)</p> <p>⑤ LINE VOLTAGE (Line Voltage Selector) (Multiple Voltage Model only)</p> | <p>⑥ AC CORD (Power Cord)</p> <p>⑦ INPUT SELECTOR SW (Lch.)</p> <p>⑧ NORMAL (Lch. Normal Input Jack)</p> <p>⑨ DIRECT (Lch. Direct Input Jack)</p> |
|--|---|

CONNECTIONS

• Connection to the speaker system

Connect the speaker system for the left channel (the left side as viewed facing the front) to the L speaker terminal on the back panel, and the speaker system for the right channel into the R terminal. There are two sets of SPEAKERS terminals. If only one speaker system is to be used, connect it to the SYSTEM A terminals.

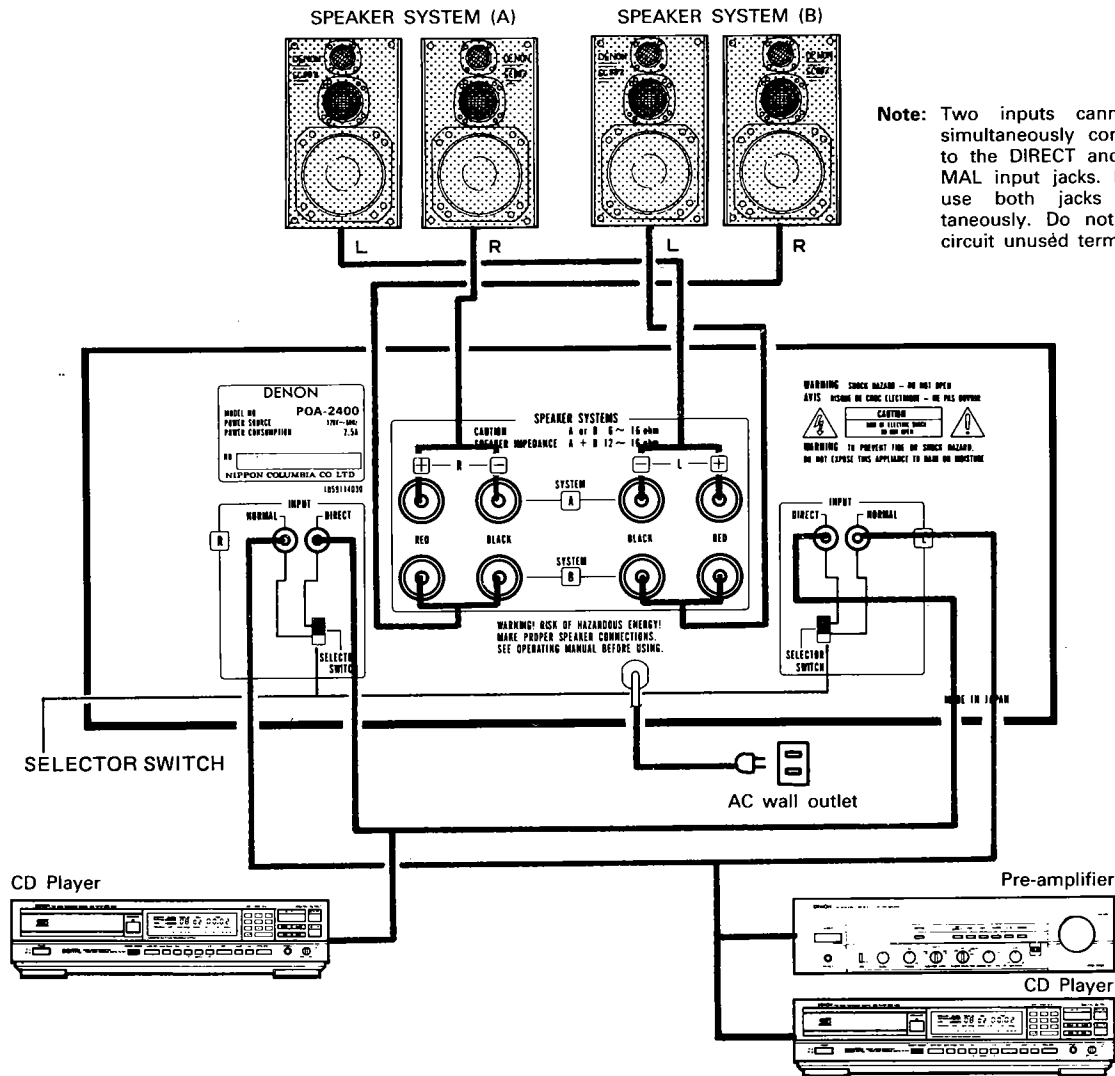

Note: Two inputs cannot be simultaneously connected to the DIRECT and NORMAL input jacks. Do not use both jacks simultaneously. Do not short-circuit unused terminals.

Fig. 3

CONNECTION PRECAUTIONS

- When making connections, make sure that the power is turned OFF.
- Make sure that the L output terminal of the preamplifier (or other audio equipment) is connected to the L input terminal of the POA-2400. Also check that the R output terminal of the preamplifier (or other audio equipment) is connected to the R input terminal of the POA-2400. Connect the cords going to the left speakers to the L terminals of the POA-2400 and the right speaker cords to the R terminals of the POA-2400.
- Make secure connections. If connections are not secure, noise or loss of sound output may occur.
- Do not bundle pin plug cords with the power cords: Please keep pin plug cords away from power supply transformers since hum or noise may occur.

For U.S.A., Canada and Asia model only.

With the DIRECT jacks the input level cannot be adjusted. Before connecting the DIRECT jacks, either turn the speaker switch off or the power switch off. Connect a component with an output level control to the DIRECT jacks.

For Europe model only.

Both the DIRECT and NORMAL terminals are feasible to adjust their input levels. The NORMAL input is provided with a built-in filter to eliminate unwanted high frequency signals.

REMOVAL OF EACH SECTION

1. Top Cover

Remove 8 screws from the both sides, 4 screws from the rear side and detach the Top Cover in the direction arrow shows.

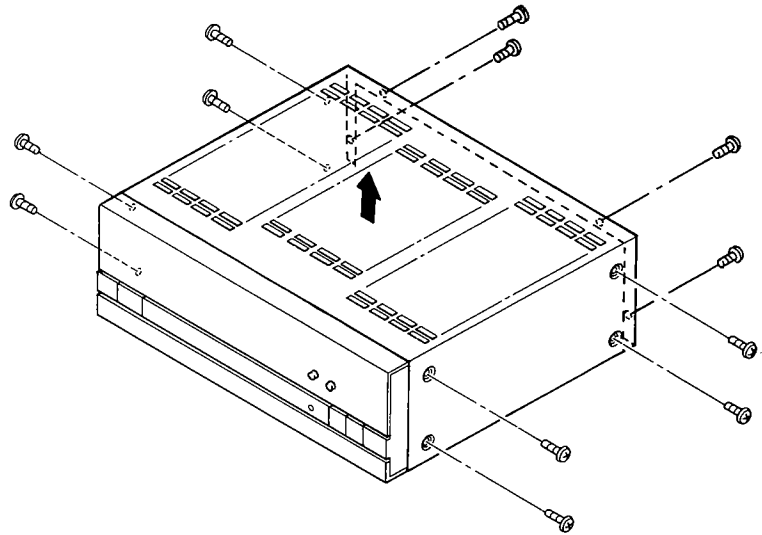

Fig. 4

2. Back Panel

Remove 8 screws from the bottom, 6 screws from the rear side, and take out the Back Panel in the direction arrow shows.

NOTE:

When remove Bottom Cover, do not take out the yellow screws.

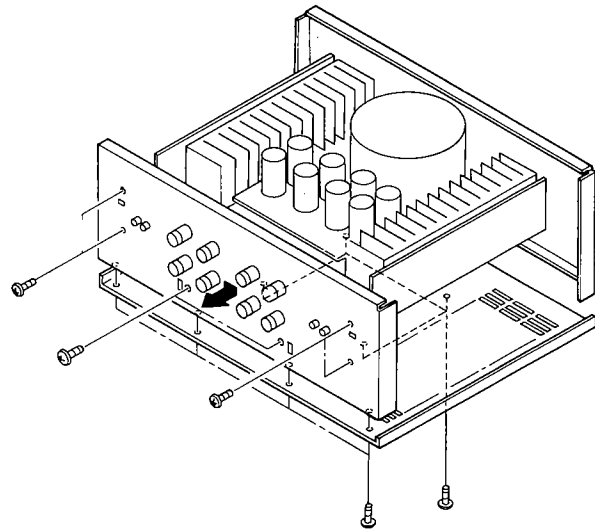

Fig. 5

3. Front Panel

Unfasten 4 screws from the bottom, 3 screws from the top, and dismantle the Front Panel.

Caution:

As illustration shows, please put a block underneath the unit and detach the Panel in a straight line to the unit. Never slant the panel nor to detach it with leaned line, this will prevent breaking of the power switch inside.

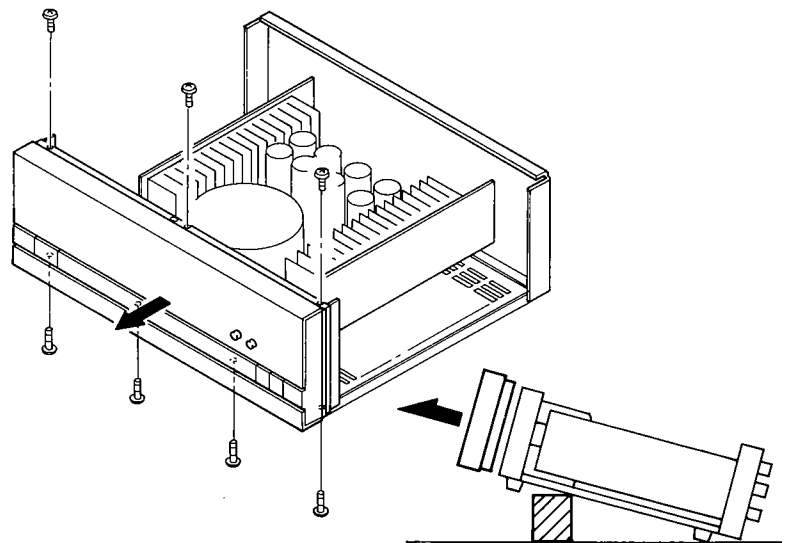

Fig. 6

METHOD OF ADJUSTMENTS

IDLE CURRENT ADJUSTMENT

● Setup

1. Keep the unit away from direct wind blown by an air-conditioner and an electric fan, and keep the unit under normal conditions. Adjust the range of ambient temperature to 15–30°C.
2. Set the following switches as follows:
 - POWER (Power switch) to off
 - INPUT LEVEL (level control) to 0 (⤵)
 - SPEAKERS (Speaker terminal) to no load (Speakers disconnected)

● Adjustment

1. Connect DC Voltmeter to Test Points (T.P) of KU-9143.
2. Turn Power Switch "ON".
3. Adjust VR501 (L ch) and VR502 (R ch) so that the DC Voltmeter reads 3 ± 0.5 mV.
4. Then after 3 minutes warmup, readjust VR501 and VR502 so that the DC Voltmeter reads 5 ± 1 mV.
5. Connect V.T.V.M. to the Speaker Terminals.
6. Set the Oscillator frequency at 1 kHz, and Output Level at 100 mV, then connect with NORMAL Input Terminal.
7. Adjust the LEVEL Control turning clockwise to obtain the indication of the V.T.V.M. connected to the Speaker Terminal becomes 2 V.
8. Confirm that the DC Voltmeter connected to the T.P. becomes slightly greater value, then adjust the VR503 and VR504 to obtain 50 ± 5 mV on the meter.
9. After 10 minutes, readjust the VR503 and VR504 for 60 ± 5 mV.

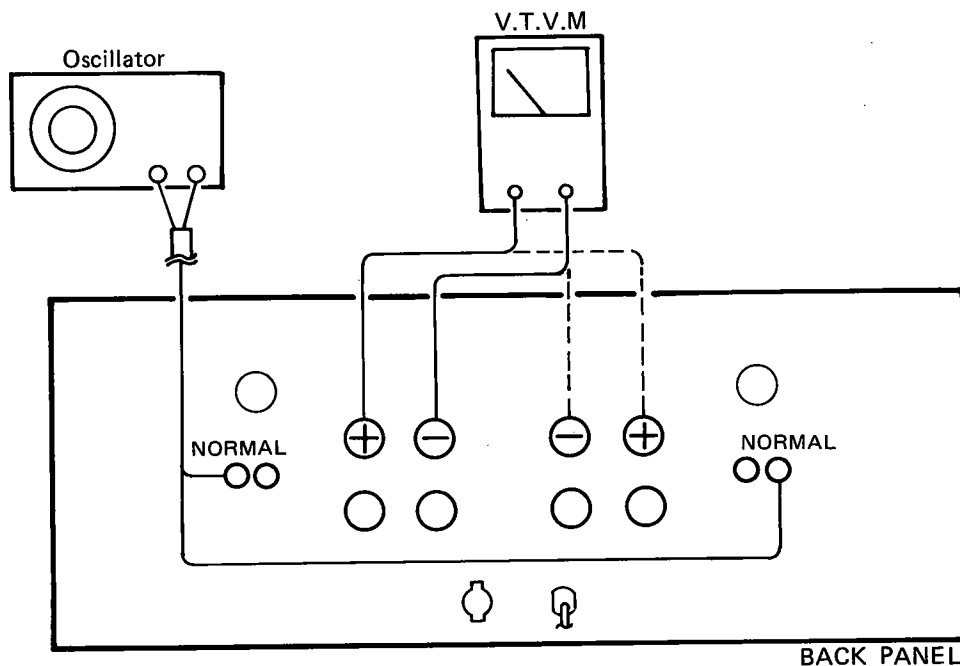

Fig. 7

ALIGNMENT POINTS
KU-9143 POWER UNIT (Component Side)

KU-9143 POWER

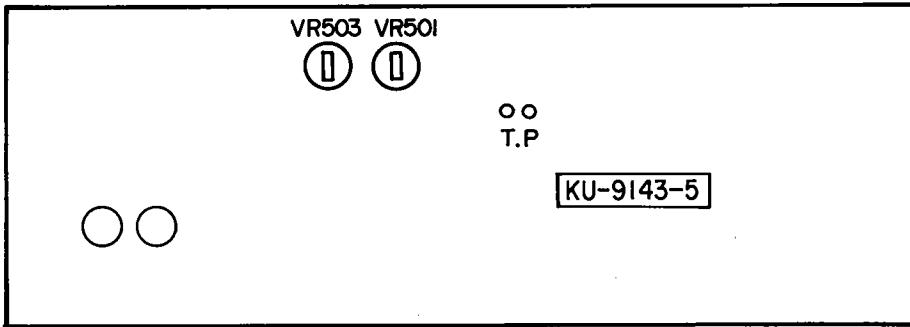
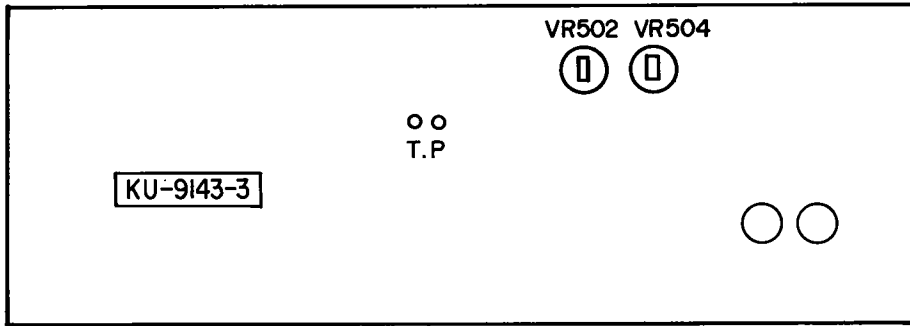

Fig. 8

TROUBLESHOOTING

Before troubleshooting, be sure to check whether your audio system is really the source of the problem.

If you think the amplifier is out of order, first check the following one more time:

1. Are all the connections correctly made?
2. Is the set being operated properly in accordance with the Operating Manual?
3. Are the speakers and preamplifier being operated correctly?

If the set does not operate properly, perform the checks indicated in the flow chart below.

If none of the items listed apply to the difficulty, the amplifier is probably out of order. Turn off the power immediately, and contact the outlet where you purchased the amplifier or your nearest DENON dealer.

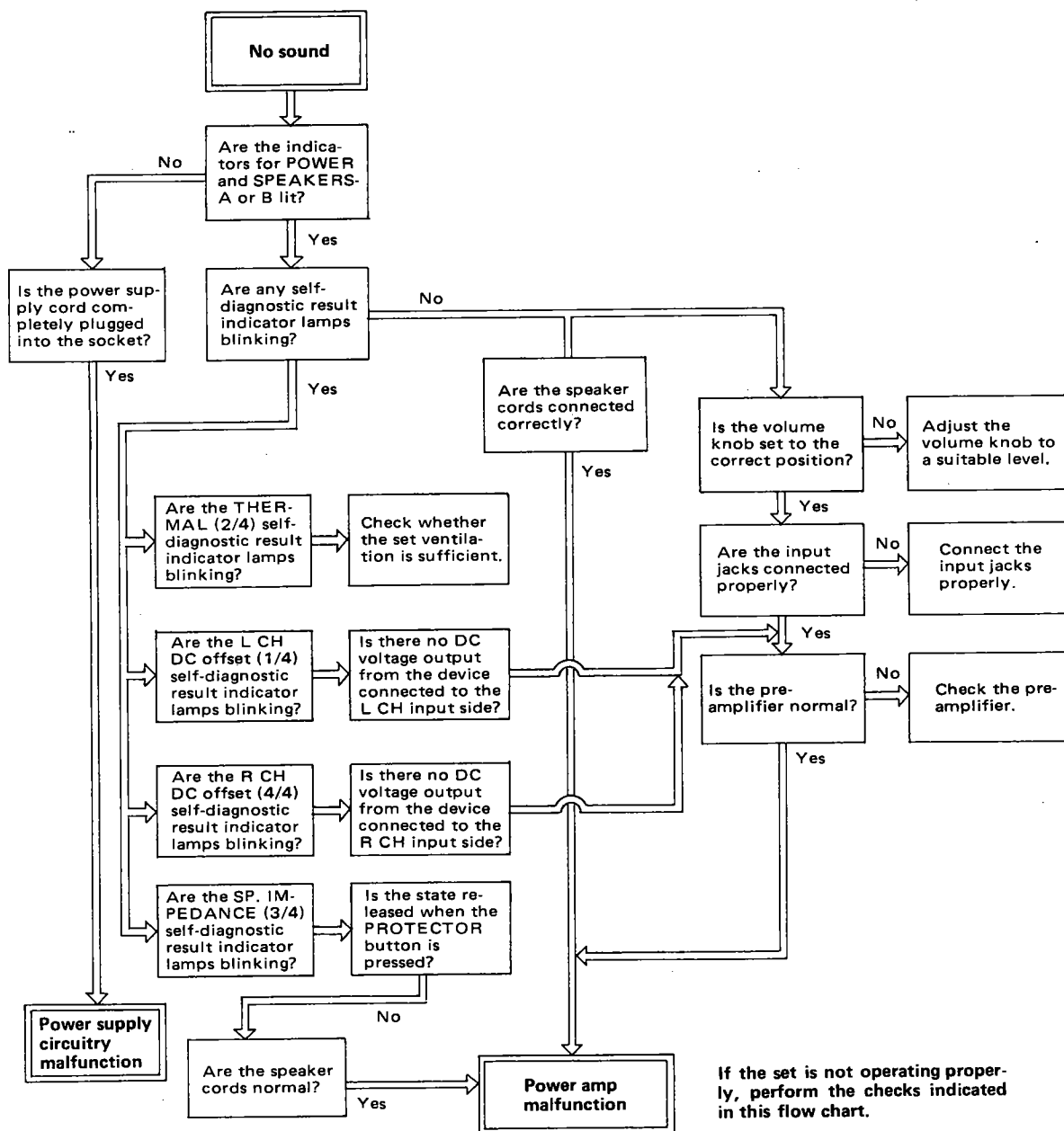

BLOCK LEVEL DIAGRAM

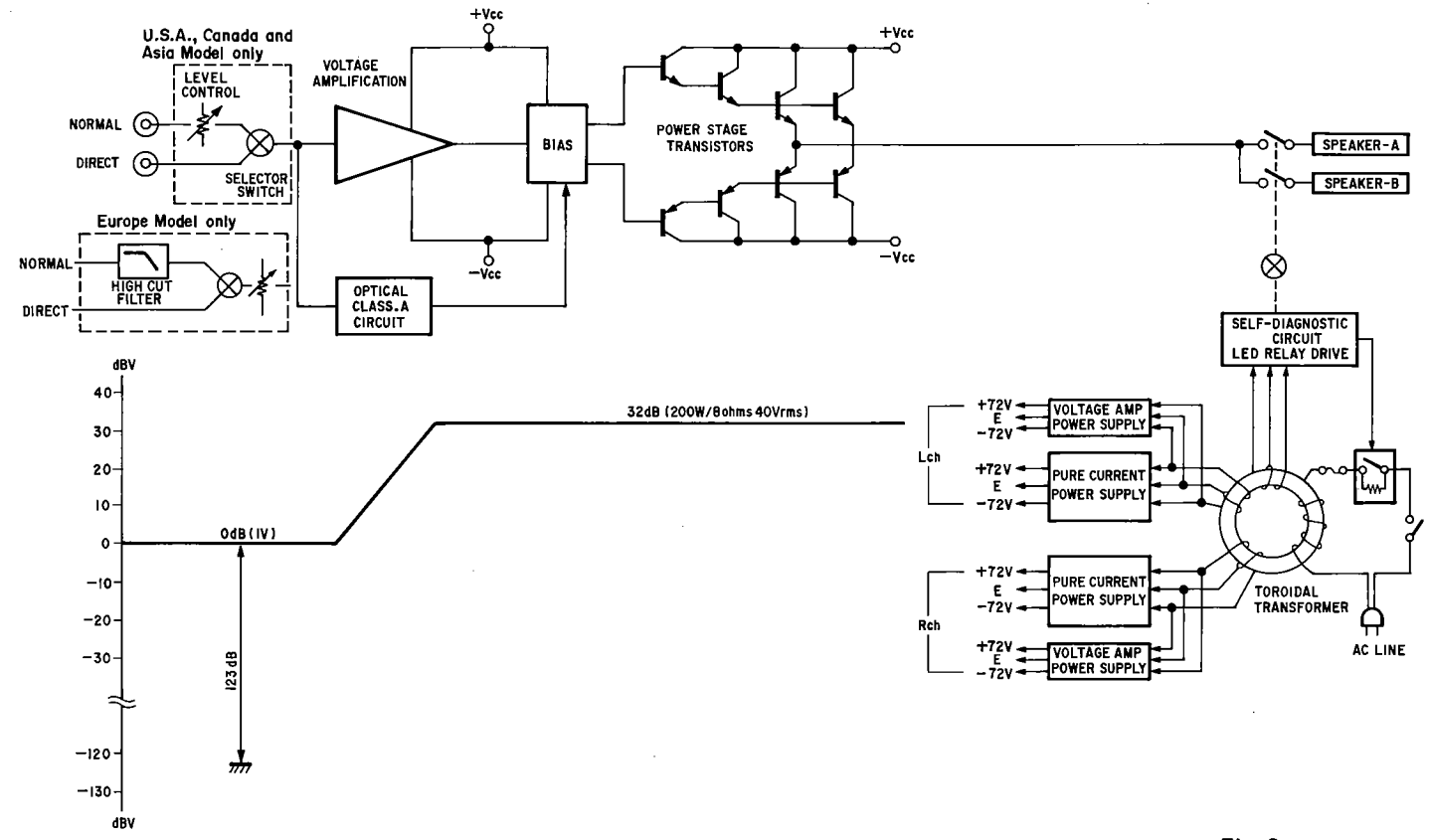
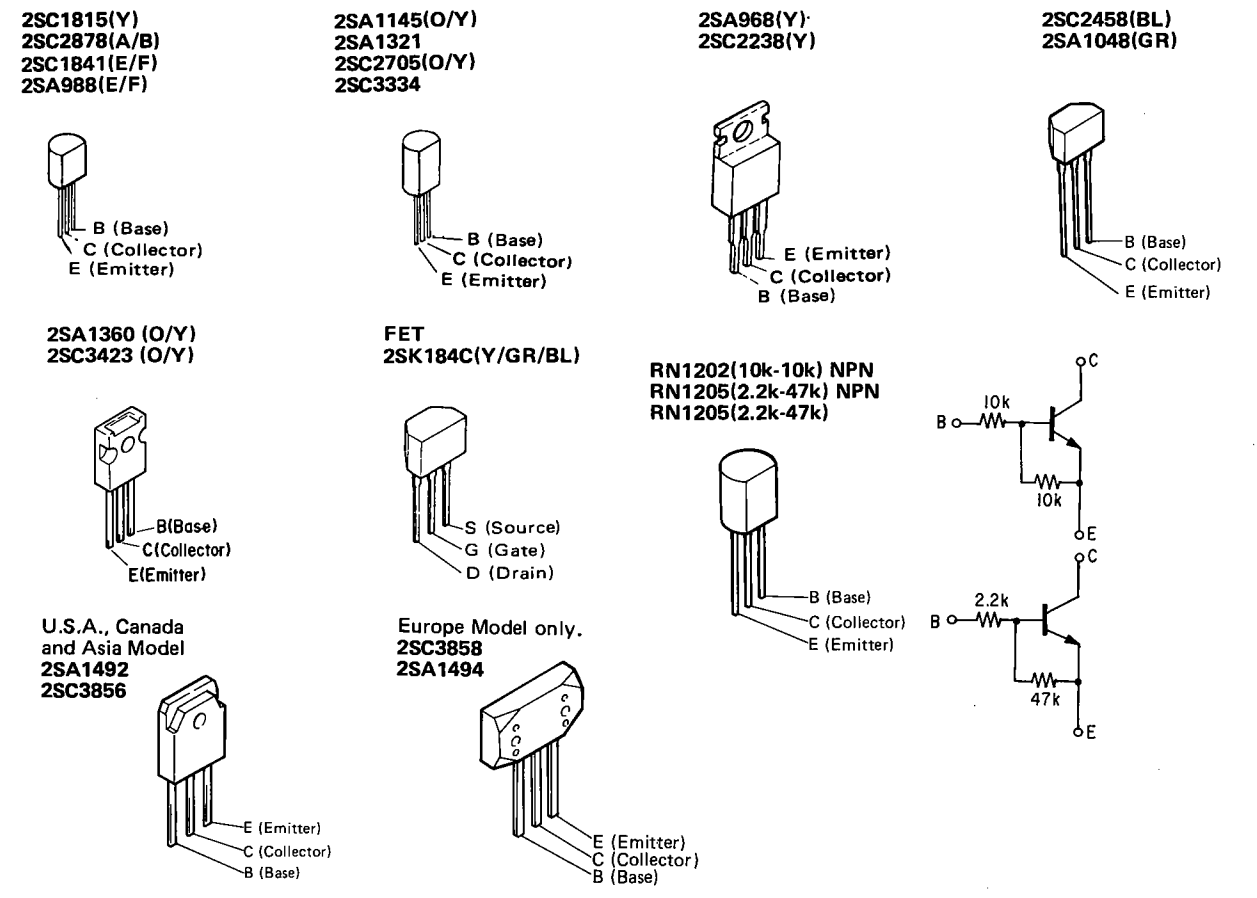
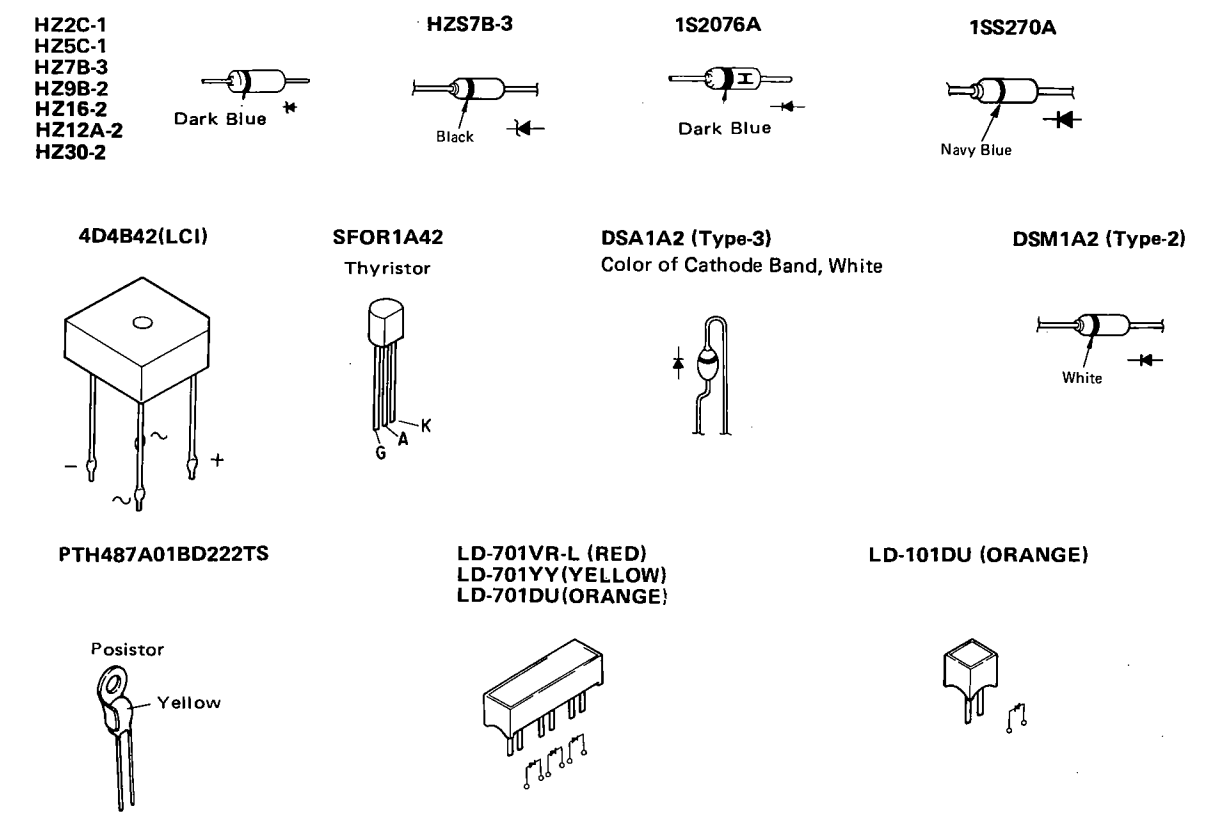

Fig. 9

• TRANSISTOR (including FET)



• DIODES (include LED's, Thyristor, Posistor)



SEMICONDUCTORS

• IC's

M5238P (Mitsubishi)

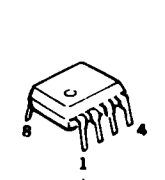

TLP521-1(BL)(Toshiba)

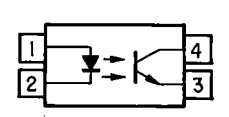
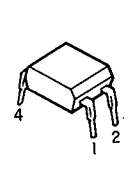

HD14001BP (Hitachi)

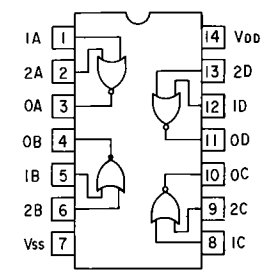
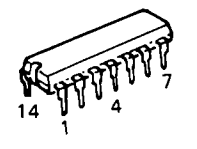

NJM78M15A(JRC)

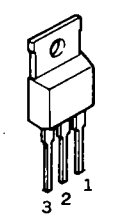

PIN CONFIGURATION
1. Output
2. Ground
3. Input

PRINTED WIRING BOARD PATTERNS
KU-9143 POWER UNIT

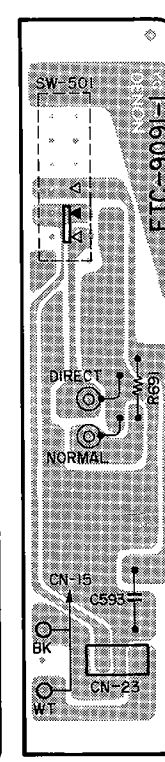
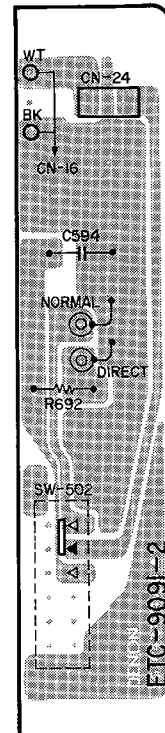
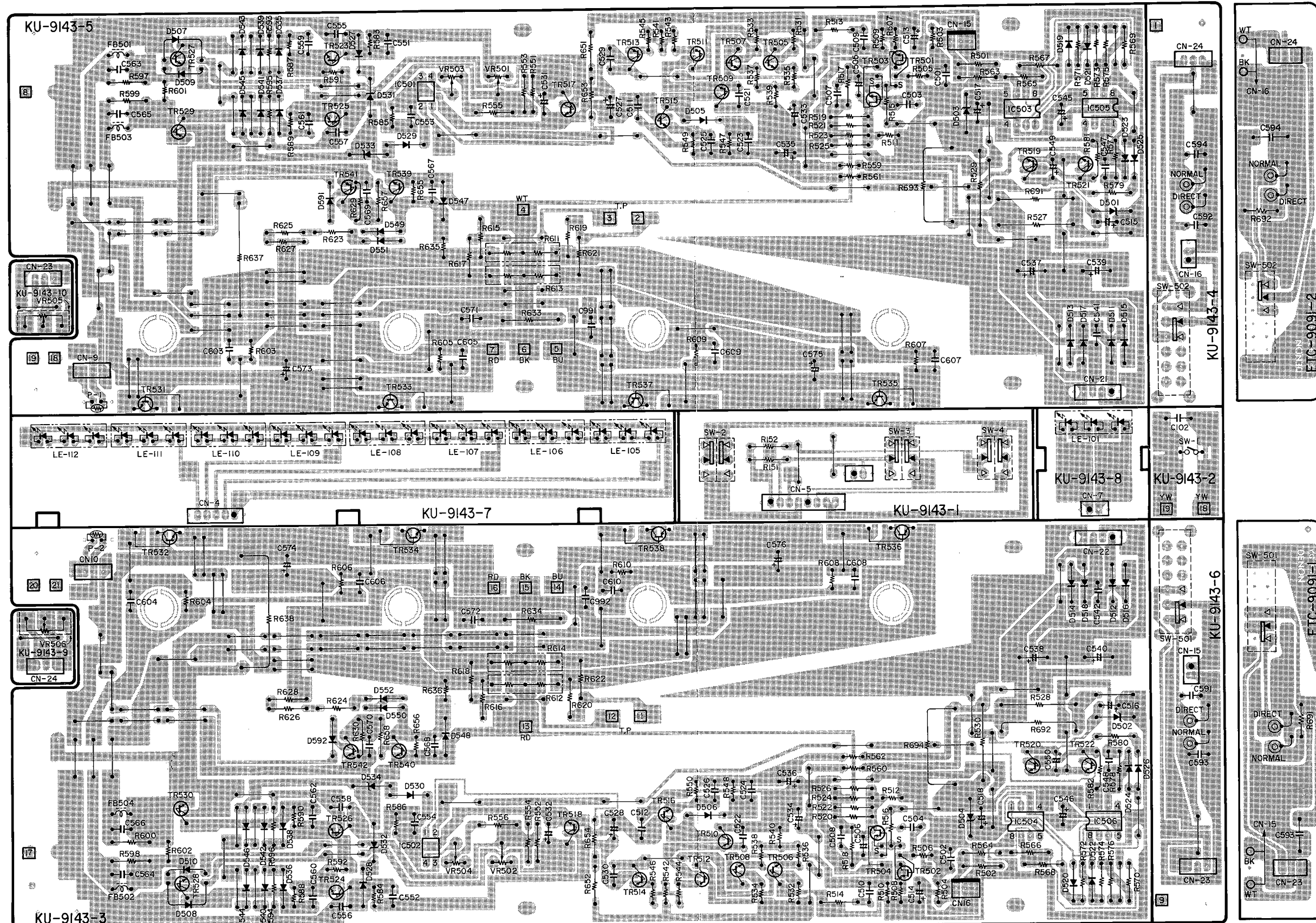

NOTE:
KU-9143-4, -6 : U.S.A., Canada & Multiple Models
ETC-9091-1, -2 : Europe, U.K. & Australia Models

ETC9071E SUPPLY UNIT

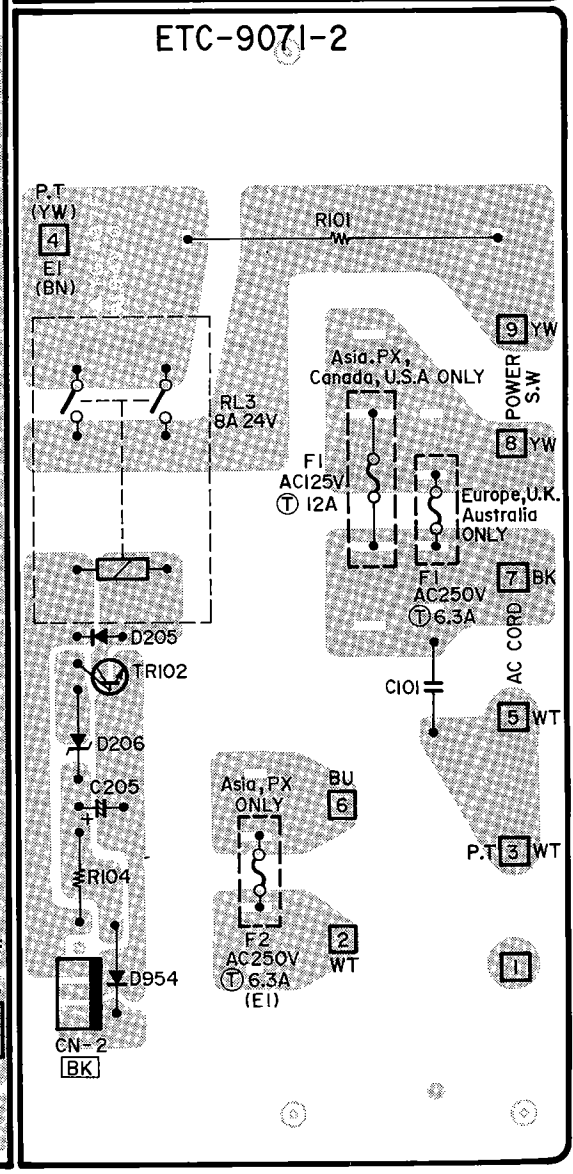
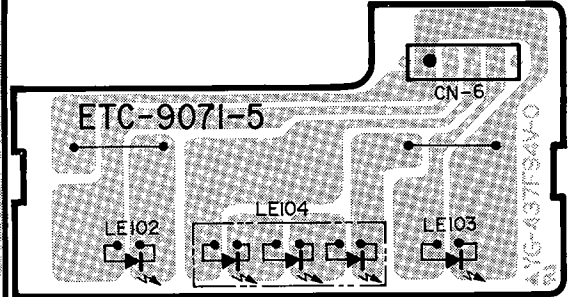
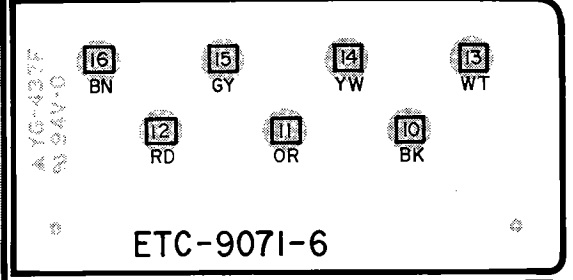
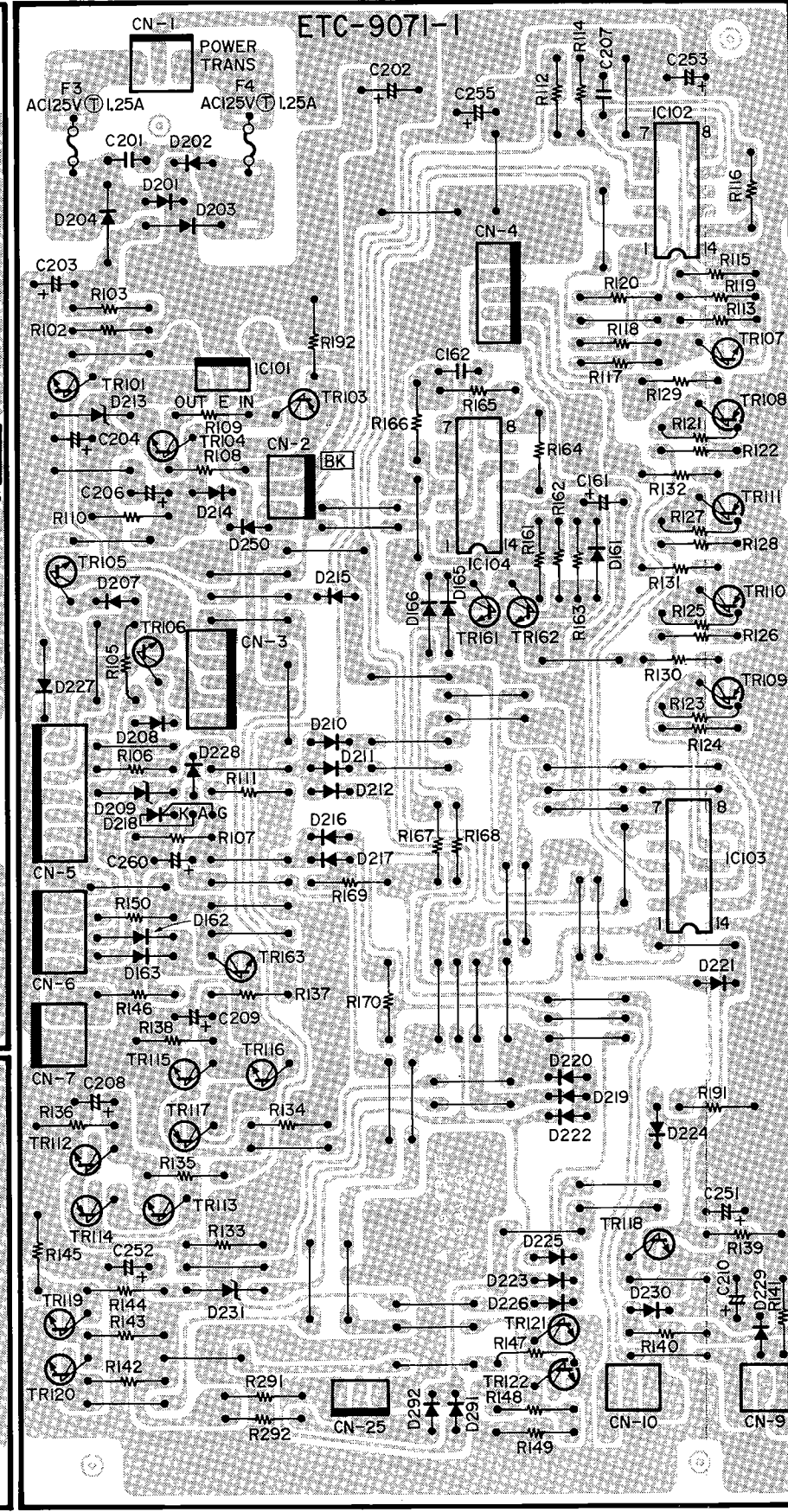
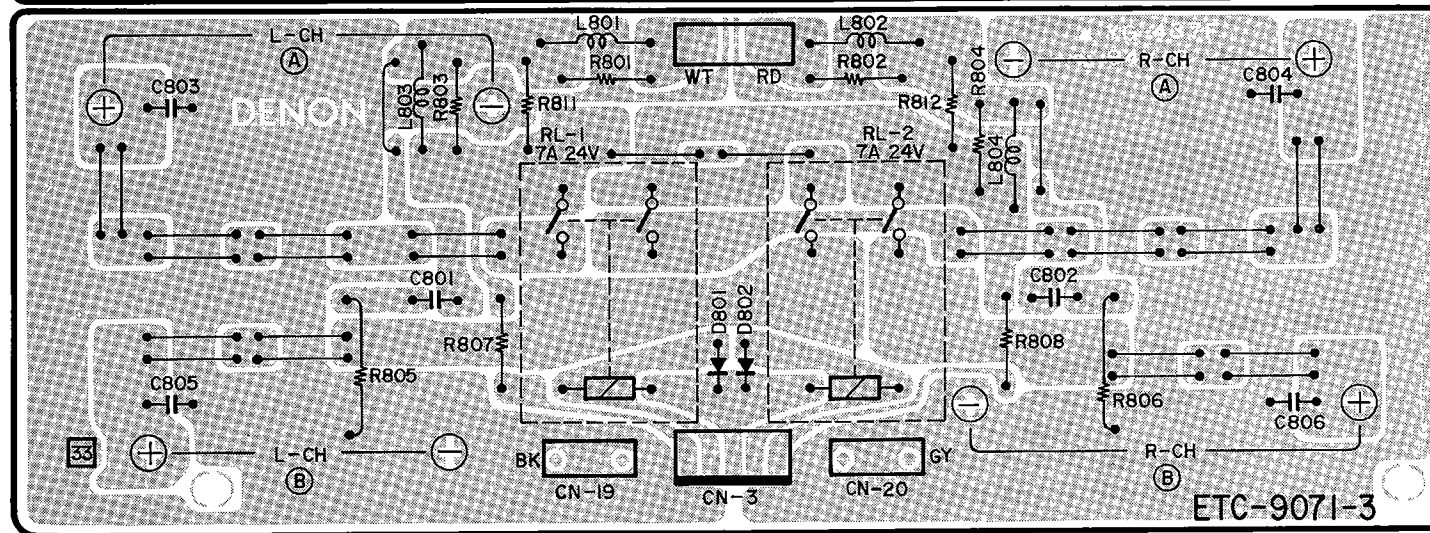
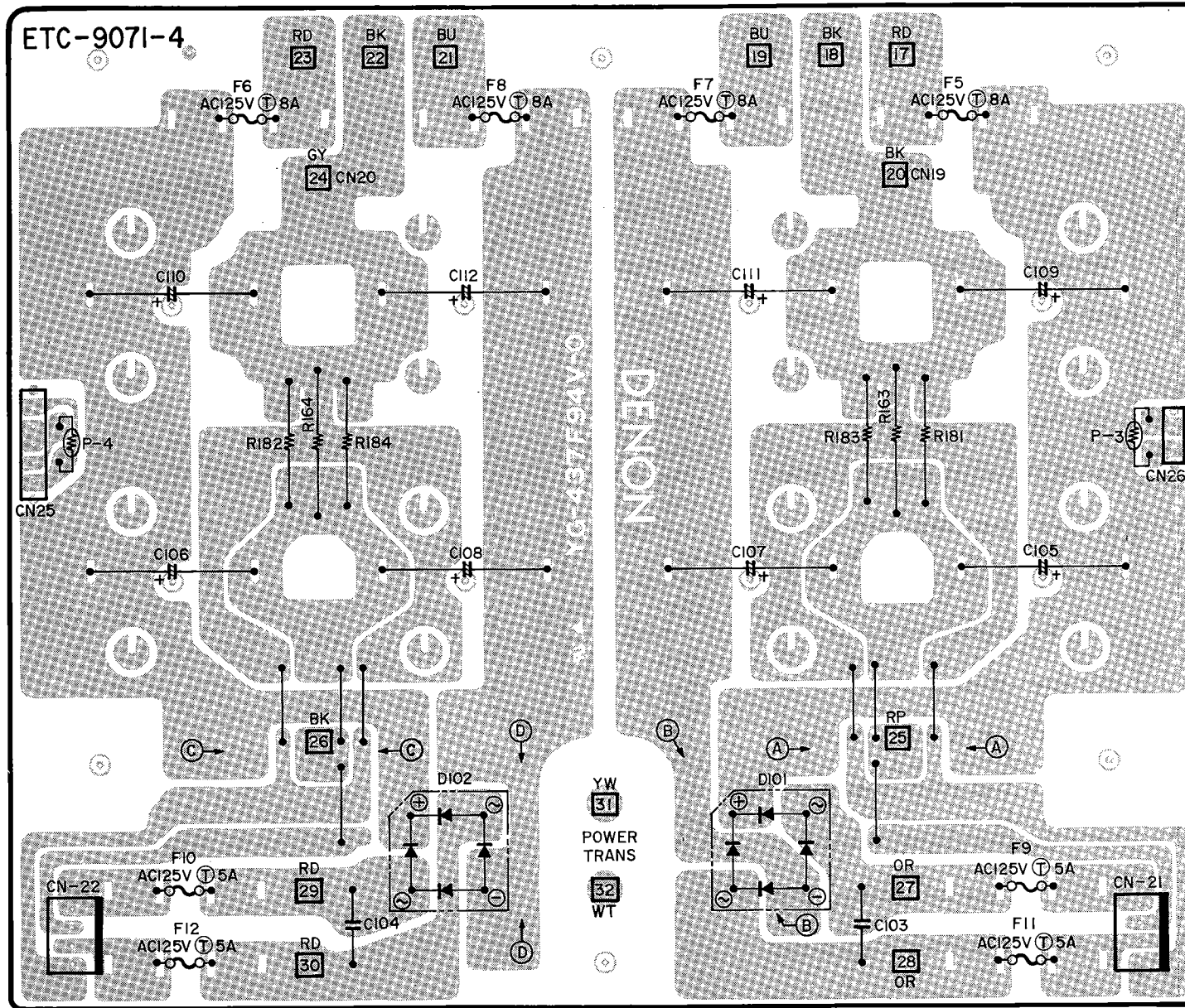

**PRINTED WIRING BOARD PARTS LIST
KU-9143 POWER UNIT PARTS LIST**

WARNING:
Parts marked with this symbol  have critical characteristics.
Use **ONLY** replacement parts recommended by the manufacturer.

Ref. No.	Part No.	Part Name	Remarks
SEMICONDUCTORS			
IC501,502	2620874009	TLP521-1 (BL)	Photo Coupler
IC503~506	2620679000	M5238P	
TR501~504	2750055002	2SK184C(Y/GR/BL)	FET
TR505~508	2730281003	2SC2705 (O)/(Y)	
TR509,510	2710168007	2SA1145 (O)/(Y)	
TR511~514	2710202002	2SA1360 (O/Y)	
TR515,516	2730332004	2SC3334	
TR517,518	2730198002	2SC1815 (Y)	
TR519,520	2690067008	RN1205 (2.2k-47k)	
TR521,522	2730235020	2SC1841 (E/F)	
TR523,524	2730332004	2SC3334	
TR525,526	2710201003	2SA1321	
TR527,528	2730199001	2SC2238 (Y)	
TR529,530	2710104003	2SA968 (Y)	
TR539,540	2730332004	2SC3334	
TR541,542	2710131021	2SA988 (E/F)	
D501~504	2760256008	HZ16-2	Zener
D505~510	2760049011	1S2076A	
D511~518	2760433009	DSM1A2 (TYPE2)	
D519~530	2760049011	1S2076A	
D531~534	2760236031	HZ5C-1	Zener
D535~552	2760049011	1S2076A	
D591,592	2760049011	1S2076A	
LE101	3939319018	LD-701DU	Orange
LE105~110	3939319034	LD-701VR-L	Red
LE112,113	3939319034	LD-701VR-L	Red
P001,002	2760289004	PTH487A01BD222TS	Positive Thermistor
RESISTORS (not included Carbon Film ±5%, 1/4W type)			
△R503,504	2412322044	RD14B2E102JNB	1kohm 1/4W ±5%
△R505,506	2412322031	RD14B2E101JNB	100ohm 1/4W ±5%
△R507~510	2412380963	RD14B2E222JNB	2.2kohm 1/4W ±5%
△R511,512	2412378920	RD14B2E221JNB	220ohm 1/4W ±5%
△R527~530	2440107024	RS14B3D562JNBF	5.6kohm 2W ±5%
△R531~534	2412378904	RD14B2E181JNB	180ohm 1/4W ±5%
△R535~538	2412376922	RD14B2E330JNB	33ohm 1/4W ±5%
△R539,540	2412379961	RD14B2E821JNB	820ohm 1/4W ±5%
△R541,542	2412377934	RD14B2E910JNB	91ohm 1/4W ±5%
△R543~546	2412387940	RD14B2E4R7JNB	4.7ohm 1/4W ±5%

Ref. No.	Part No.	Part Name	Remarks
△R547~550	2412322031	RD14B2E101JNB	100ohm 1/4W ±5%
△R559~562	2412387908	RD14B2E010JNB	1ohm 1/4W ±5%
△R583~586	2412379987	RD14B2E102JNB	1kohm 1/4W ±5%
△R587~590	2412322031	RD14B2E101JNB	100ohm 1/4W ±5%
△R591,592	2412379903	RD14B2E471JNB	470ohm 1/4W ±5%
△R601,602	2412378904	RD14B2E181JNB	180ohm 1/4W ±5%
△R603~610	2412387940	RD14B2E4R7JNB	4.7ohm 1/4W ±5%
△R611~614	2432033038	RW==3DR18R18	0.18ohm ×2 2W
△R633,634	2440017020	RS14B3A100JNBF	10ohm 1W ±5%
△R635,636	2412380905	RD14B2E122JNB	1.2kohm 1/4W ±5%
△R637,638	2440169020	RS14B3F223JNBF	22kohm 3W ±5%
△R655,656	2412380905	RD14B2E122JNB	1.2kohm 1/4W ±5%
△R691~694	2440107024	RS14B3D562JNB	5.6kohm 2W ±5%
VR501,502	2116064006	V06PB103	10kohm (20kHz T.H.D) Semi Fixed Resistor
VR503,504	2116064019	V06PB473	47kohm (Bias) Semi Fixed Resistor
	2119053001	V16V35FB503	50kohm (INPUT VR)
CAPACITORS			
△C102	2538003014	CK46E2GAC472M	4700pF ±20% 400V AC (POWER SW)
C501~504	2554229940	CQ92P2A221J	220pF ±5% 100V
C505,506	2543056959	CE04D1H100MBP (SME)	10μF/50V
C507,508	2521086912	CM92C2A050D	5pF/100V ±0.5pF
C509,510	2551121025	CQ93M1H103J	0.01μF/50V ±5%
C511,512	2521085926	CM92C2A680J	68pF/100V ±5%
C513~518	2544260087	CE04W1H100M (SME)	10μF/50V ±20%

Ref. No.	Part No.	Part Name	Remarks
C521,522	2521086938	CM92C2A100D	10pF/100V ±0.5pF
C523,524	2554229908	CQ92P2A101J	100pF/100V ±5%
C525,526	2551249907	CQ93M1H471J (B)	470pF/50V ±5%
C527,528	2544263084	CE04W2A100M (SME)	10μF/100V ±20%
C529,530	2521086938	CM92C2A100D	10pF/100V ±0.5pF
C531,532	2544260045	CE04W1H010M (SME)	1μF/50V ±20%
C533~536	2543046008	CE04D2A010MBP	1μF/100V ±20%
C537~540	2544229002	CE04W2A471M	470μF/100V ±20%
C541,542	2531151905	CK45E2H472P	4700pF/500V +100 -0%
C545,546	2544260087	CE04W1H100M (SME)	10μF/50V ±20%
C547,548	2554213972	CQ93M1H103J (B)	0.01μF/50V ±5%
C549,550	2544299906	CE04W1C100M (SRE)	10μF/16V ±20%
C551~554	2554229908	CQ92P2A101J	100pF/100V ±5%
C555~558	2521085900	CM92C2A270J	27pF/100V ±5%
C559~562	2554213927	CQ93M1H152J (B)	1500pF/50V ±5%
C563~566	2561034092	CF93A1H154J	0.15μF/50V ±5%
C567~570	2554213972	CQ93M1H103J (B)	0.01μF/50V ±5%
C571,572	2554228967	CQ92P2A103J	0.01μF/100V ±5%
C573~576	2544263084	CE04W2A100M (SME)	10μF/100V ±20%
SWITCHES & COIL			
△	2129534002	POWER SW (PUSH)	
SW501,502	2129536000	3P PUSH SWITCH	SP SW
	2124311107	SLIDE SWITCH	
OTHER PARTS			
FB501~504	2359006009	BL02RN1-R62	4
	2050233032	3P EH CONNECTOR BASE	6
	2050243022	2P WIRE HOLDER	6
	2050243048	4P WIRE HOLDER	2

Ref. No.	Part No.	Part Name	Remarks
	2050243051	5P WIRE HOLDER	1
	2050243080	8P WIRE HOLDER	1
	2030275007	1P CONTACT Ass'y	1
	2050315002	2P CONNECTOR BASE	2
	2050190036	3P NH CONNECTOR BASE	2

WARNING:
Parts marked with this symbol  have critical characteristics.
Use ONLY replacement parts recommended by the manufacturer.

ETC9071E SUPPLY UNIT PARTS LIST

Ref. No.	Part No.	Part Name	Remarks
SEMICONDUCTORS			
IC101	2680217004	NJM78M15A	
IC102~104	2620298009	HD14001BP	
TR101	2730253015	2SC2878 (A/B)	
TR102	2730317003	2SC2458 (BL)	
TR103	2710191003	2SA1048 (GR)	
TR104~107	2730317003	2SC2458 (BL)	
TR108~111	2710191003	2SA1048 (GR)	
TR112,113	2730317003	2SC2458 (BL)	
TR114	2710191003	2SA1048 (GR)	
TR115,116	2730317003	2SC2458 (BL)	
TR117	2710191003	2SA1048 (GR)	
TR118~122	2730317003	2SC2458 (BL)	
TR161	2690025008	RN1202 (10k-10k)	
TR162	2730317003	2SC2458 (BL)	
TR163	2690025008	RN1202 (10k-10k)	
D101,102	2760424005	4D4B42 (LC1)	
D161~163	2760049011	1S2076A	
D165,166	2760049011	1S2076A	
D201,202	2760427015	DSA1A2 (TYPE-3)	
D203,204	2760049011	1S2076A	
D205	2760432000	1SS270A	
D206	2760236031	HZ5C-1	
D207,208	2760432000	1SS270A	
D209	2760218033	HZ9B-2	
D210~212	2760432000	1SS270A	
D213	2760254000	HZ7B-3	
D214~217	2760432000	1SS270A	
D218	2790016001	SF0R1A42	
D219~226	2760432000	1SS270A	
D227	2760049011	1S2076A	
D228	2760465022	HZS7B-3	
D229,230	2760432000	1SS270A	
D231	2760368019	HZ2C-1	
D250	2760432000	1SS270A	
D801,802	2760432000	1SS270A	
LE102,103	3939223010	LD-101DU	
LE104	3939319021	LD-701 YY	
RESISTORS (not included Carbon Film ±5%, 1/4W type)			
AR101	2432044001	RW78A4A1R2K=	1.2ohm ±10% 10W
AR192	2412387908	RD14B2E010JNBST	1ohm ±5% 1/4W
AR805,806	2440025025	RS14B3A470JNBF	47ohm ±5% 1W
CAPACITORS			
C101	2538003014	CK45E2GAC472M	4700pF/400V AC ±20%

Ref. No.	Part No.	Part Name	Remarks
C103,104	2561043711	CF93B2E474K	0.47 μF/250V ±10%
C161	2544260032	CE04W1HR47M (SME)	0.47 μF/50V ±20%
C162	2561034034	CF93A1H473J	0.047 μF/50V ±5%
C201	2554199973	CQ92M1H103J (MRZ)	0.01 μF/50V ±5%
C202	2544168095	CE04W1V102MF	1000 μF/35V ±20%
C203	2544260032	CE04W1HR47M (SME)	0.47 μF/50V ±20%
C204	2544260045	CE04W1H010M (SME)	1 μF/50V ±20%
C205	2544250039	CE04W0J221M (SME)	220 μF/6.3V ±20%
C206	2544254019	CE04W1C220M (SME)	22 μF/16V ±20%
C207	2561035017	CF93A1H224J	0.22 μF/50V ±5%
C208,209	2544252037	CE04W1A101M (SME)	100 μF/10V ±20%
C210	2544254006	CE04W1C100M (SRA)	10 μF/16V ±20%
C251	2531024003	CK45F1H103Z	0.01 μF/50V +80 -20%
C252	2544256004	CE04W1E100M (SME)	10 μF/25V ±20%
C253	2544195929	CE04W1V100M (SRA)	10 μF/35V ±20%
C260	2544254019	CE04W1C220M (SME)	22 μF/16V ±20%
C801,802	2554228996	CQ92P2A223J	0.022 μF/100V ±5%
RELAYS & COILS			
L801~804	2359001004	INDUCTOR	(POWER OUT 1 μH)
RL001,002	2140041008	RELAY	24V, 7A
RL003	2140115002	RELAY	
OTHER PARTS			
	4170253000	RADIATOR	1
	4700012022	Cross Pan Screw with S.W.,W 3×12	1
	2020022008	FUSE HOLDER	20
	EP-5870	FUSE HOLDER	2
ΔF001	2061051009	FUSE 12A	1
ΔF003,004	2061039047	FUSE 1.25A	2

Ref. No.	Part No.	Part Name	Remarks
ΔF005~008	2061046014	FUSE 8A	4
ΔF009~012	2061046027	FUSE 5A	4
	2050075025	2P TERMINAL	SP L.R. 1
	2050234031	3P EH SID CONN. BASE	2
	2050190036	3P NH CONNECTOR BASE	4
	2050190049	4P NH CONNECTOR BASE	3
	2050190052	5P NH CONNECTOR BASE	3
	2050190078	7P NH CONNECTOR BASE	1
	2050243048	4P WIRE HOLDER	1
	2050243022	2P WIRE HOLDER	2

KU-9143S (for Europe)

[Same as KU-9143 (for U.S.A.) except the followings]

Ref. No.	Part No.	Part Name	Remarks
SWITCH			
Δ	2129525008	POWER SW	C
OTHER PARTS			
	4150298001	CONDENSER COVER	C102 A

NOTE: A: Add C: Change D: Delete

ETC9071V (for PX)

[Same as ETC9071E (for U.S.A.) except the followings]

Ref. No.	Part No.	Part Name	Remarks
RESISTOR			
R101	2432044014	RW78A4A2R2K=	2.2ohm 10W C
RELAY			
RL003	2140115002	RELAY	C
OTHER PARTS			
ΔF001	2061017043	FUSE 12A	C
ΔF002	2061035038	FUSE 6.3A (T)	A
ΔF003,004	2061035025	FUSE 1.25A (T) (2)	C
ΔF005~008	2061052008	FUSE 8A (4)	C
ΔF009~012	2061035012	FUSE 5A (T) (4)	C
	2020022008	FUSE HOLDER (2)	A

NOTE: A: Add C: Change D: Delete

ETC9071S (for Europe)

[Same as ETC9071E (for U.S.A.) except the followings]

Ref. No.	Part No.	Part Name	Remarks
RESISTOR			
R101	2432044027	RW78A4A4R7K=	4.7ohm 10W C
CAPACITORS			
C803~806	2554228938	CQ92P2A472J (4)	4700pF/100V A ±5% FTZ
	2561043708	CF93B2E224K (2)	0.22 μF/250V C FTZ
RELAY			
RL003	2140115002	RELAY	C
OTHER PARTS			
	2020022008	FUSE HOLDER (2)	C
ΔF001	2061036011	FUSE (6.3A)	C
ΔF003,004	2061015016	FUSE (1.25A) (2)	PRO & MUT C
ΔF005~008	2061036011	FUSE (6.3A) (4)	C
ΔF009~012	2061015090	FUSE (5A) (4)	DRIVER Vcc C
	5139151003	FUSE LABEL (2)	T 6.3A A

NOTE: A: Add C: Change D: Delete

WIRING DIAGRAM

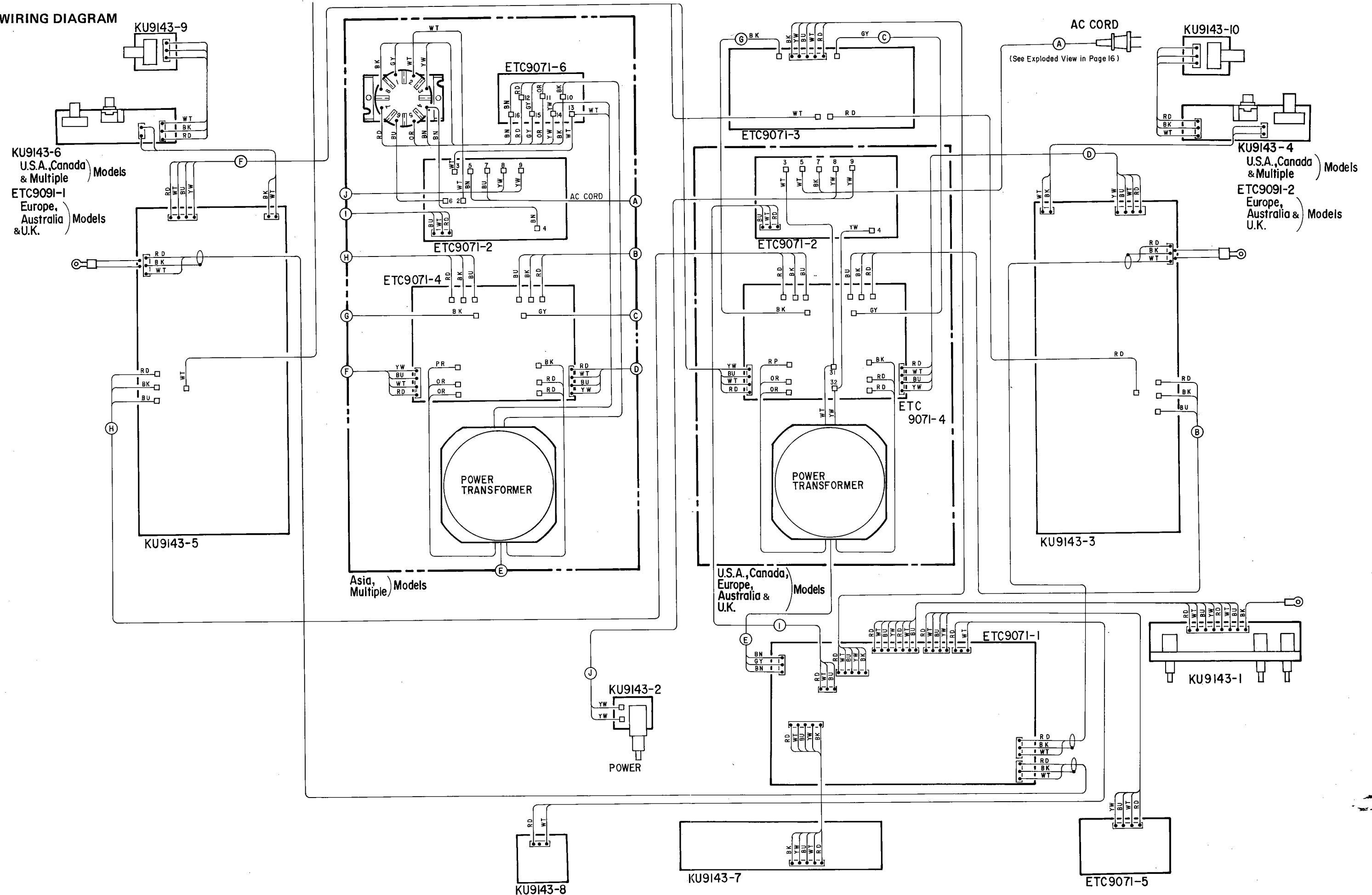

SCHEMATIC DIAGRAM

1 2 3 4 5 6 7 8 9 10 11

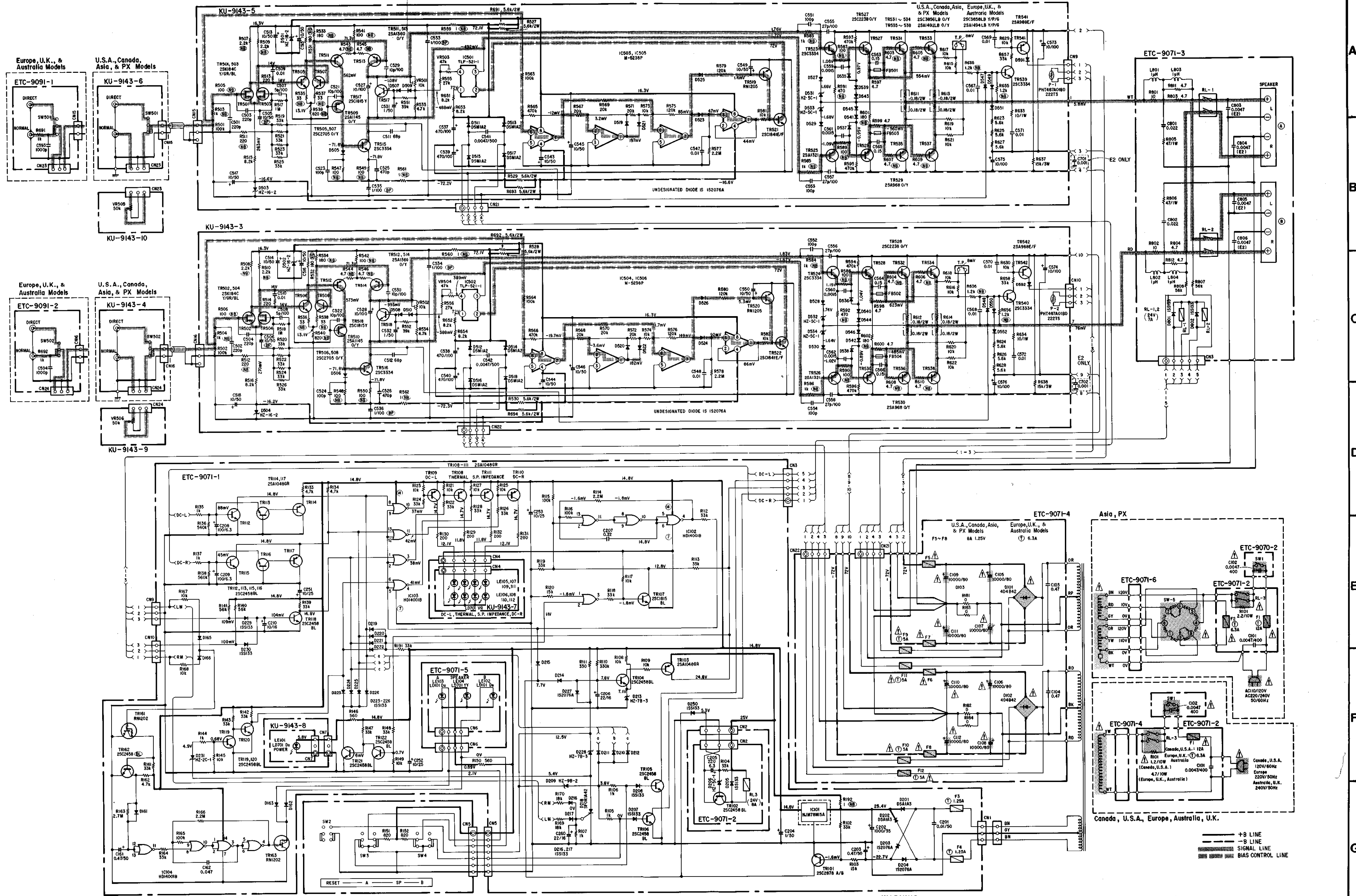

WARNING:
Parts marked with this symbol have critical characteristics. Use ONLY replacement parts recommended by the manufacturer.

CAUTION:
Before returning the unit to the customer, make sure you make either (1) a leakage current check or (2) a line to chassis resistance check. If the leakage current exceeds 0.5 milliamps, or if the resistance from chassis to either side of the power cord is less than 240 k ohms, the unit is defective.

WARNING:
DO NOT return the unit to the customer until the problem is located and corrected.

EXPLODED VIEW OF CHASSIS AND CABINET & PARTS LIST
 • EXPLODED VIEW OF CHASSIS AND CABINET

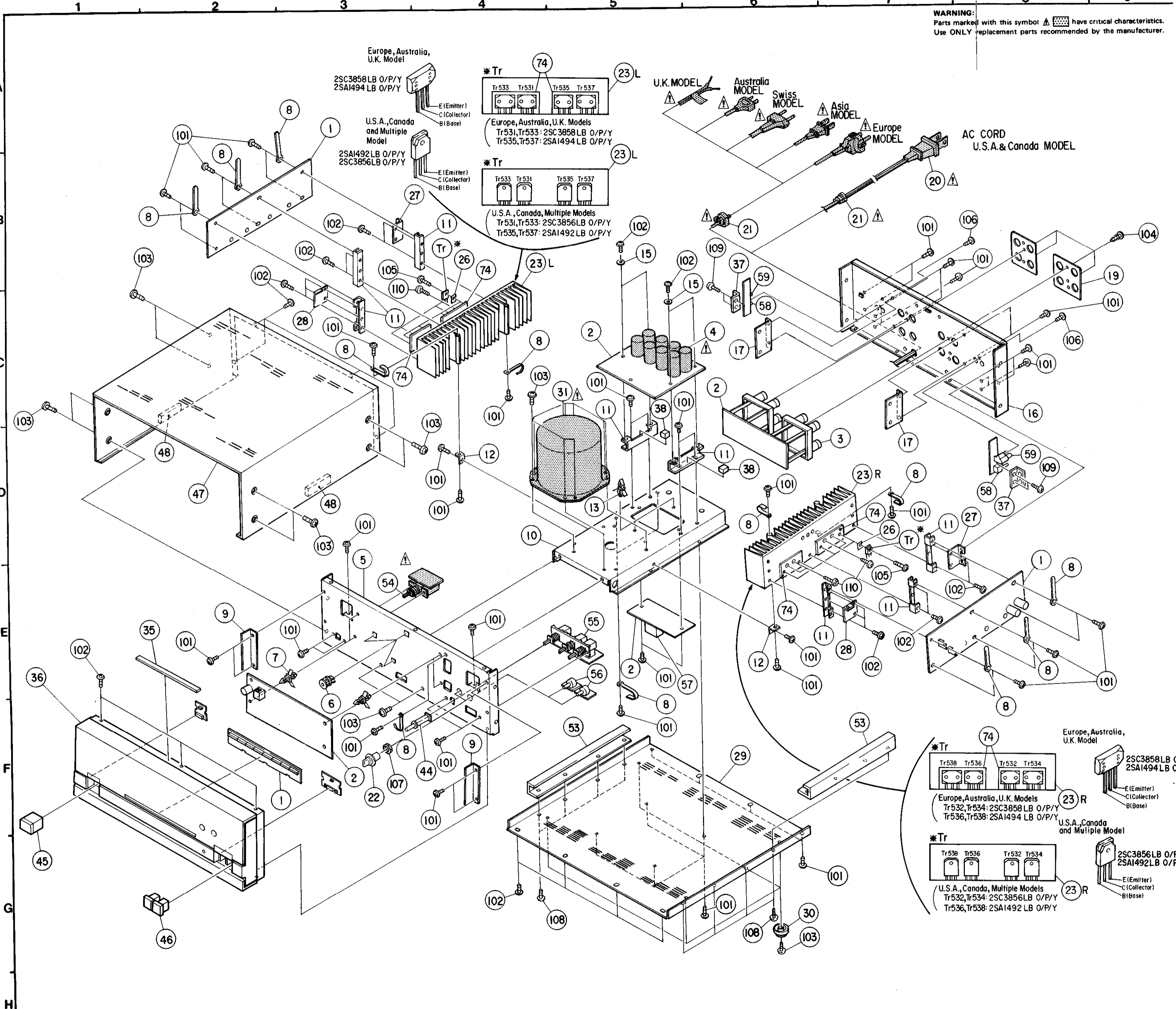

WARNING:
 Parts marked with this symbol have critical characteristics.
 Use ONLY replacement parts recommended by the manufacturer.

PARTS LIST OF EXPLODED VIEW

Ref. No.	Part No.	Part Name & Descriptions	Q'ty
⊙ *1	KU-9143	POWER UNIT	1
⊙ *2	ETC9071E	SUPPLY UNIT	1
3	2050316001	4P TERMINAL (SPEAKER)	2
⊙ 5	4119029208	FRONT CHASSIS	1
⊙ 6	4439015002	P.W. SPACER	3
⊙ 7	4159016019	P.C.B. HOLDER	4
⊙ 8	4450048016	CORD HOLDER (L50)	13
⊙ 9	4121477000	BRACKET	2
⊙ 10	4119028005	TRANS CHASSIS	1
⊙ 11	4129062006	PWB SUPPORT BRACKET	8
⊙ 12	4129059008	BRACKET	2
⊙ 13	4159016008	P.C.B. HOLDER	2
⊙ *14	2034319011	3P CONNECTOR CORD	1
⊙ 15	4419028006	SP. W. PLATE	4
*16	1059114137	BACK PANEL	1
⊙ 17	4129041001	PWB SUPPORT	2
⊙ *18	2038161003	5P CONNECTOR CORD	1
19	4159014105	PROTECTOR SHEET	2
⊙ 20	4049000002	AC CORD (POLARIZED)	1
⊙ 21	4490000005	CORD (USH 14-2)	1
22	1129041004	KNOB	2
⊙ *23	4179034107	POWER RADIATOR	2
24	-	-	4
25	-	-	4
26	4150234007	INSULATING SHEET (U.S.A., Canada, Multiple Models)	8
26	4159044007	INSULATING SHEET (Europe, Australia, U.K. Models)	8
⊙ 27	4129060008	RADIATOR BRACKET (R)	2
⊙ 28	4129081104	RADIATOR BRACKET (F)	2
29	1059116009	BOTTOM COVER	1
30	1049012207	FOOT ASS'Y	4
⊙ *32	2034486038	3P EH-EH CON. CORD	1
⊙ *33	2034486041	3P EH-EH CON. CORD	1
**34	4450033005	WIRE CLAMP BAND	8
35	1220095014	SPACER 0.81 5×220	1
36	AF71A04	FRONT PANEL SUB ASS'Y	1
⊙ 37	4129090007	SLIDE SW BRACKET	2
⊙ 38	4619013002	CUSHION	2
44	1139087100	PUSH KNOB (PROTECTOR)	1
45	1139081108	PUSH KNOB ASS'Y (P)	1
46	1139084103	PUSH KNOB ASS'Y (SP)	2
47	1029016003	TOP COVER	1
48	4619001043	RUBBER SHEET	2
*49	5139148029	FUSE LABEL	1
*50	5139148032	FUSE LABEL	1
*51	5139148003	FUSE LABEL	1
*52	5139148016	FUSE LABEL	1
⊙ 53	4129081207	SUPPORT BRACKET	2
55	2129536000	3P PUSH SWITCH (SP SW)	1
56	2119053001	V16V35FB503 50kohms (INPUT VR)	2
57	2140115002	RELAY (RL003)	1
58	2124311107	SLIDE SWITCH (SW501,502)	2
59	2050315002	2P CONNECTOR BASE (INPUT)	2
⊙ *60	2034486012	3P EH-EH CON. CORD (CN-23)	1
⊙ *61	2034486025	3P EH-EH CON. CORD (CN-24)	1
SCREWS & WASHER			
*101	4737002034	TAPPING SCREW (S) 3×6 (BLACK)	65
102	4737002021	TAPPING SCREW (S) 3×8 (BLACK)	25
103	4737007000	TAPPING SCREW (S) 4×8 (BLACK)	24
104	4737508017	TAPPING SCREW (P) 3×10 (BLACK)	4
*105	4738007009	CUP SCREW 3×12	8
106	4770064107	TAPPING SCREW 3×10 (BLACK)	2
107	-	NUT M7	2
108	4737002005	TAPPING SCREW (S) 3×6	8
109	4713201024	TAPPING SCREW (S) 2.6×4	4
PACKING & ACCESSORIES (not included EXPLODED VIEW)			
*201	5138266009	DANGEROUS MARK	1
202	-	-	-
203	5049102003	STYLEN PAPER 0.51 800×650	1
204	5050075051	CABINET COVER 0.021 850W×450D	1
205	5039168002	CUSHION	2
*206	5019157020	CARTON CASE	1
*207	5119244008	INST MANUAL	1
*208	5150418107	DA1 WARRANTY HOME (U.S.A)	1
	5150388004	DCI WARRANTY (Canada)	1

WARNING:

Parts marked with this symbol  have critical characteristics.
Use ONLY replacement parts recommended by the manufacturer.

ADDENDUM LIST

Ref. No.	Part Name & Descriptions	Part No.		
		Multi. voltage	Europe	Swiss
1	POWER UNIT	KU-9143	KU-9143S	KU-9143S
2	SUPPLY UNIT	ETC9071V	ETC9071S	ETC9071S
16	BACK PANEL	1059114124	1059114108	1059114108
Δ 20	AC CORD	2006031026	2062070005 (250V 6A C2)	2062072003 (250V 6A SEV)
Δ 21	CORD BUSH	4450028007	4450020005	4450020005
23	POWER RADIATOR	4179034107(2)	4179042005(2)	4179042005(2)
Δ 31	POWER TRANS	2339558001	2339559000	2339559000
34	WIRE CLAMP BAND	4450033005(10)	4450033005(6)	4450033005(6)
*70	VOLTAGE SEL SW	2129555007	—	—
*71	BRACKET (B)	4129065003	—	—
*72	SAFETY COVER	4149022000	—	—
*73	PUSH RIVET	4770210016(2)	—	—
74	CU PLATE	—	4179041006(4)	4179041006(4)
	(Europe, Australia & U.K. Models only)			
101	TAPPING SCREW (S) 3×6 (BLACK)	4737002034(71)	4737002034(65)	4737002034(65)
105	CUP SCREW (3×12)	4738007009(8)	—	—
	CUP SCREW (3×14)	—	4738007038(16)	4738007038(16)
110	CUP SCREW (3×8)	—	4738007025(8)	4738007025(8)
201	DANGEROUS MARK	—	—	—
206	CARTON CASE	5019111147	5019111147	5019111147
207	INST MANUAL	5119244008	5119239000	5119239000
208	DA1 WARRANTY HOME	5158052206	—	—
	(WARRANTY IN ENVELOPE)			
211	PRESET LABEL	5150290008	—	—

Note:

1. See addendum list above for the parts with asterisk (*) on the Ref. No. and the other parts not included in the list.
2. * marked not included EXPLODED VIEW OF CHASSIS AND CABINET.
3. This list is prepared based on U.S.A BLACK VERSION.
4. Part indicated with the mark "⊙" are not always in stock and possibly to take a long period of time for supplying, or in some case supplying of part may be refused.

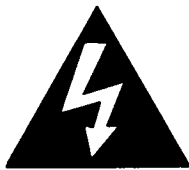

CAUTION

RISK OF ELECTRIC SHOCK
DO NOT OPEN



CAUTION: TO REDUCE THE RISK OF ELECTRIC SHOCK, DO NOT REMOVE COVER (OR BACK). NO USER SERVICEABLE PARTS INSIDE. REFER SERVICING TO QUALIFIED SERVICE PERSONNEL.



The lightning flash with arrowhead symbol within an equilateral triangle is intended to alert the user of the presence of uninsulated "dangerous voltage" within the product's enclosure that may be of sufficient magnitude to constitute a risk of electric shock to persons.



The exclamation point within an equilateral triangle is intended to alert the user of the presence of important operating and maintenance (servicing) instructions in the literature accompanying the appliance.

NIPPON COLUMBIA CO., LTD.

14-14, 4-CHOME AKASAKA,
MINATO-KU, TOKYO 107 JAPAN
TEL: 03-584-8111
TLX: JAPANOLA J22591
CABLE: NIPPONCOLUMBIA TOKYO