

# DENON

For Europe model

Ver. 1

## SERVICE MANUAL

# MODEL PMA-SA1

### INTEGRATED AMPLIFIER

#### 注意

サービスをおこなう前に、このサービスマニュアルを必ずお読みください。本機は、火災、感電、けがなどに対する安全性を確保するために、さまざまな配慮をおこなっており、また法的には「電気用品安全法」にもとづき、所定の許可を得て製造されております。従ってサービスをおこなう際は、これらの安全性が維持されるよう、このサービスマニュアルに記載されている注意事項を必ずお守りください。

● For purposes of improvement, specifications and design are subject to change without notice.

● 本機の仕様は性能改良のため、予告なく変更することがあります。  
● 補修用性能部品の保有期間は、製造打切後8年です。

● Please use this service manual with referring to the operating instructions without fail.

● 修理の際は、必ず取扱説明書を参照の上、作業を行ってください。

● Some illustrations using in this service manual are slightly different from the actual set.

● 本文中に使用しているイラストは、説明の都合上現物と多少異なる場合があります。

## DENON, Ltd.

TOKYO, JAPAN

## SAFETY PRECAUTIONS

The following check should be performed for the continued protection of the customer and service technician.

### LEAKAGE CURRENT CHECK

Before returning the unit to the customer, make sure you make either (1) a leakage current check or (2) a line to chassis resistance check. If the leakage current exceeds 0.5 milliamps, or if the resistance from chassis to either side of the power cord is less than 460 kohms, the unit is defective.

#### 注意

サービス、点検時には次のことにご注意願います。

#### ●注意事項をお守りください！

サービスのとき特に注意を必要とする個所については、キャビネット、部品、シャーシなどにラベルや捺印で、注意事項を表示しています。これらの注意書きおよび取扱説明書などの注意事項を必ずお守りください。

#### ●感電に注意！

- (1) このセットは、交流電圧が印加されていますので、通電時に内部金属部に触れると感電することがあります。従って通電サービス時には、絶縁トランスの使用や手袋の着用、部品交換には、電源プラグを抜くなどして、感電にご注意ください。
- (2) 内部には、高電圧の部分がありますので、通電時の取扱には、十分ご注意ください。

#### ●指定部品の使用！

セットの部品は難燃性や耐電圧など安全上の特性を持ったものとなっています。従って交換部品は、使用されていたものと同じ特性の部品を使用してください。特に配線図、部品表に△印で指定されている安全上重要な部品は必ず指定のものをご使用ください。

#### ●部品の取付けや配線の引きまわしは、元どおりに！

安全上、テープやチューブなどの絶縁材料を使用したり、プリント基板から浮かして取付けた部品があります。また内部配線は引きまわしやクランプによって発熱部品や高圧部品に接近しないように配慮されていますので、これらは必ず元どおりにしてください。

#### ●サービス後は安全点検を！

サービスのために取り外したねじ、部品、配線などが元どおりになっているか、またサービスした個所の周辺を劣化させてしまったところがないかなどを点検し、外部金属端子部と、電源プラグの刃の間の絶縁チェックをおこなうなど、安全性が確保されていることを確認してください。

#### (絶縁チェックの方法)

電源コンセントから電源プラグを抜き、アンテナや、プラグなどを外し、電源スイッチを入れます。500V絶縁抵抗計を用いて、電源プラグのそれぞれの端子と、外部露出金属部〔アンテナ端子、ヘッドホン端子、マイク端子、入力端子など〕との間で、絶縁抵抗値が1MΩ以上であること、この値以下のときは、セットの点検修理が必要です。

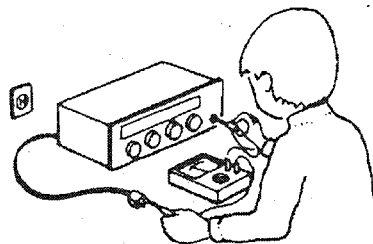

#### 注意

安全上重要な部品について

本機に使用している多くの電気部品、および機構部品は安全上、特別な特性を持っています。この特性はほとんどの場合、外観では判別つきにくく、また、もとの部品より高い定格（定格電力、耐圧）を持ったものを使用しても安全性が維持されるとは、限りません。安全上の特性を持った部品は、このサービスマニュアルの配線図、部品表につきのように表示していますので、必ず指定されている部品番号のものを使用願います。

(1)配線図… △マークで表示しています。

(2)部品表… △マークで表示しています。

指定された部品と異なるものを使用した場合には、感電、火災などの危険を生じる恐れがあります。

DIMENSION

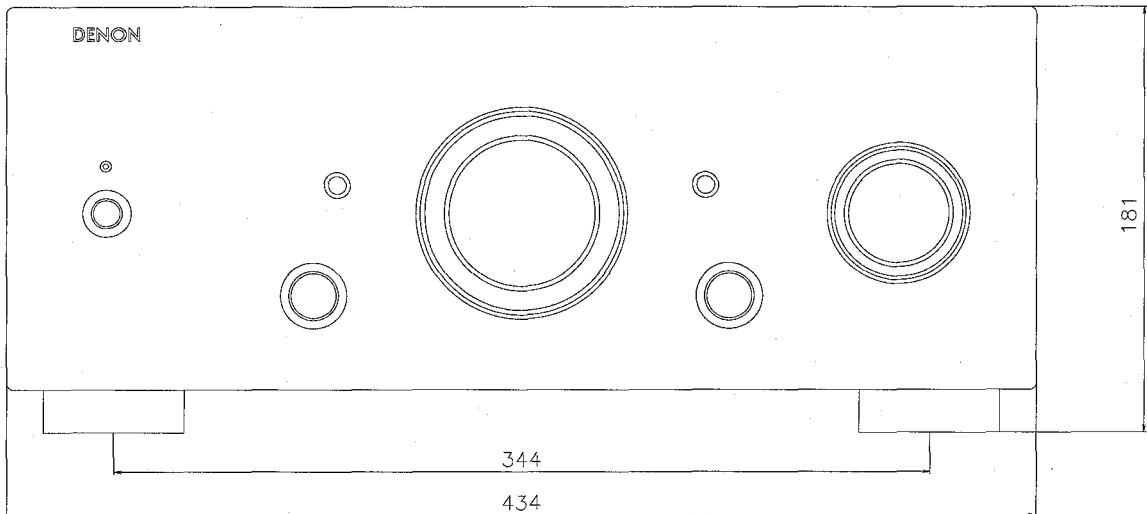
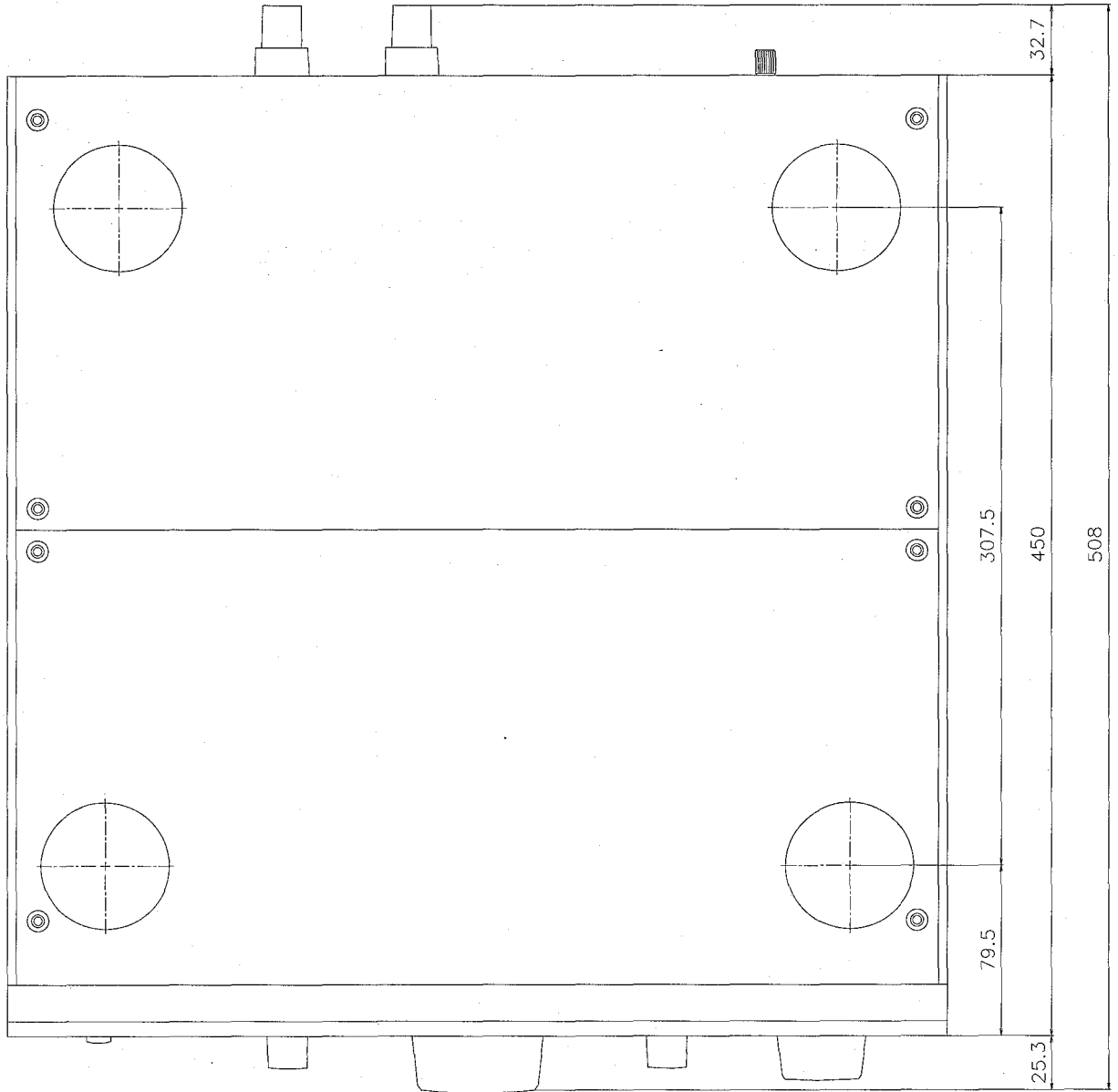

# ADJUSTMENT

## VOLTAGE AMPLIFIER STAGE

### 1. Output Offset Voltage Adjustment for Distortion Eliminating Circuit

Connect 2 DC Voltmeters across TP1 and TP3 to GND with the Balanced Input set at ON, turn the Master Volume minimum (extremely left), and rotate VR601 so as to obtain absolute value difference of TP1 and TP3 DC voltage becomes no greater than 100mV.

Perform the same manner as per the above and rotate VR602 by means of connecting DC Voltmeters to TP2 and TP4 to make adjustment for Rch.

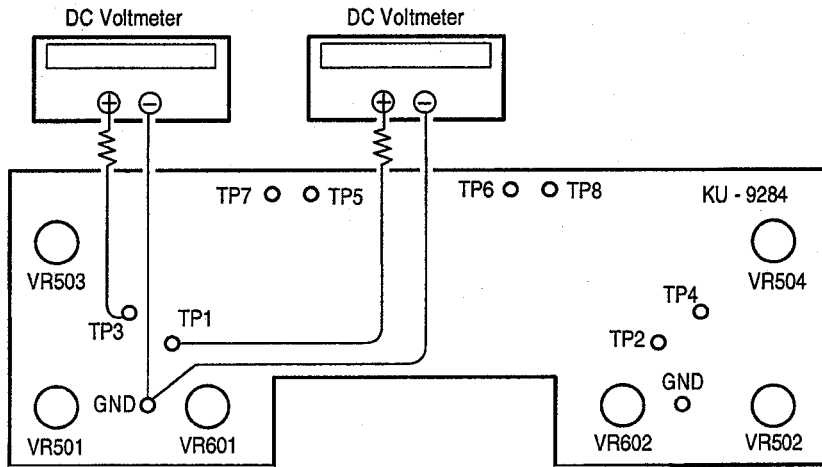

### 2. Output Offset Voltage Adjustment for Voltage Amplifier Stage

Connect a DC Voltmeter across TP5 and GND with the Balanced Input set at ON, turn the master Volume minimum (extremely left) so as to obtain TP5 DC Voltmeter within  $\pm 5\text{mV}$  when rotating VR501.

Next, connect a DC Voltmeter to TP7 and obtain the DC voltage within  $\pm 5\text{mV}$  with the adjustment of VR503.

Perform the same manner as per the above and rotate VR502, VR504 by means of connecting DC Voltmeters to TP6 and TP8 to make adjustment for Rch.

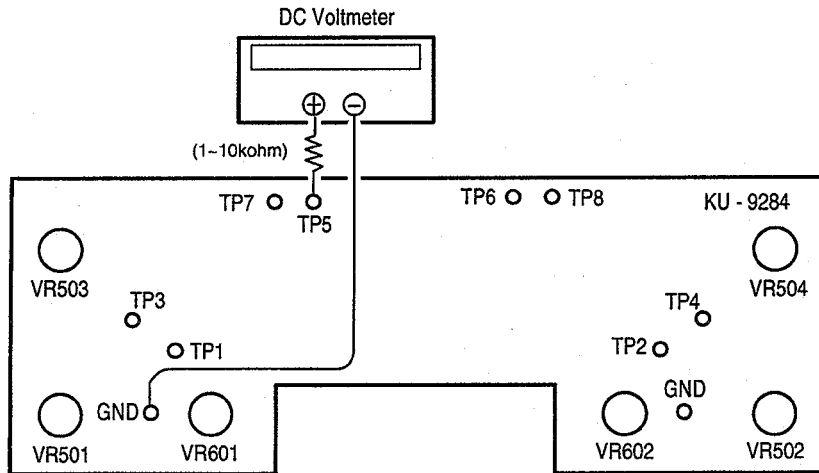

Note 1: Be sure to connect a oscillation preventive resistor (1kohm ~ 10kohm) on the tip of DC Voltmeter probe.

Note 2: An aging of more than 10 minutes is essential prior to perform the above adjustment.

## POWER AMPLIFIER STAGE

### 1. Idle Current Adjustment

Turn VR451~VR454 fully counterclockwise.

Set the Master Volume to minimum (extremely left) and turn the power switch ON.

Connect a DC voltmeter to Test Point TP401 and obtain a DC voltage at the same Test Point as follows.

Turn VR451 clockwise and adjust the voltage to  $25\text{mV} \pm 5\text{mV}$ .

Keep warm up 10 minutes, adjust the above voltage to  $45\text{mV} \pm 5\text{mV}$ .

Adjust the idle current with TP403 and VR453, TP402 and VR452, TP404 and VR454 the same procedure as to the above for Lch Reversal Amplifier, Rch Non-reversal Amplifier and Reversal Amplifier.

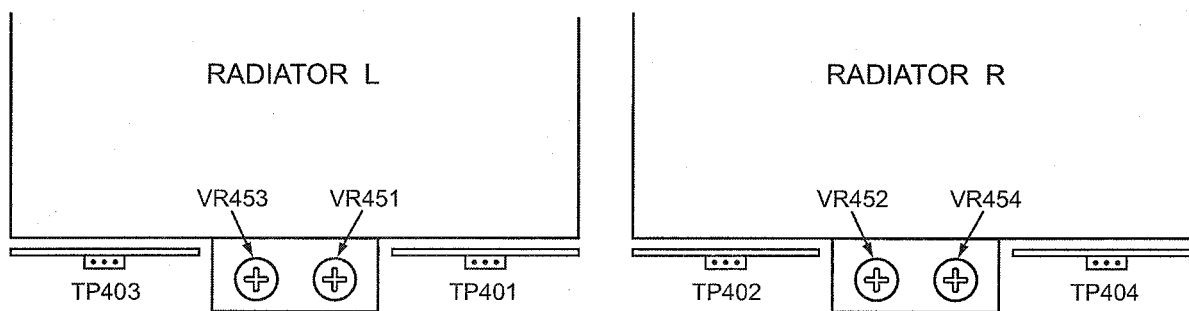

# BLOCK AND LEVEL DIAGRAM

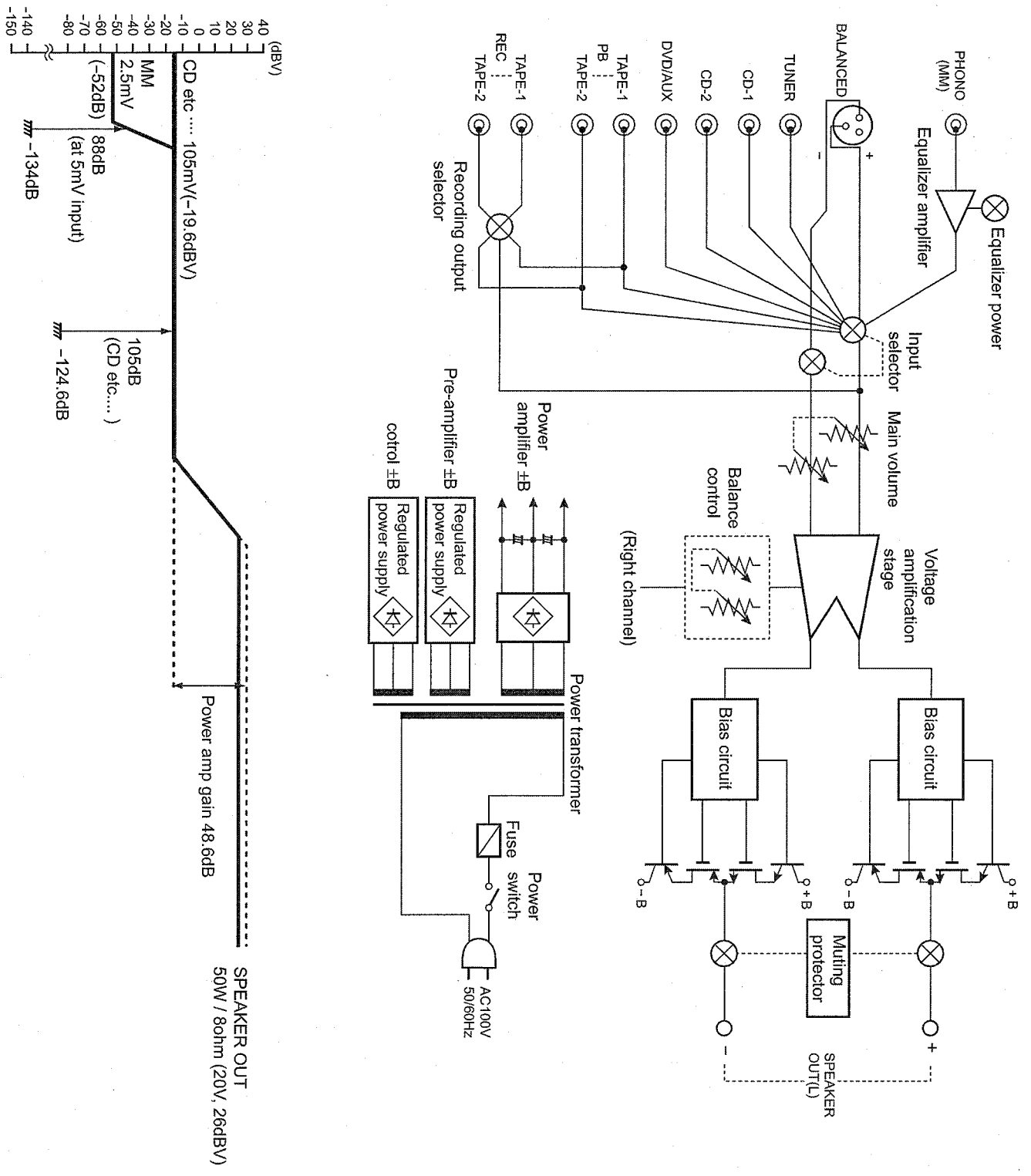

# SEMICONDUCTORS

Only major semiconductors are shown, general semiconductors etc. are omitted to list.  
 主な半導体を記載しています。汎用の半導体は記載を省略しています。

## 1. IC's

### BU4538

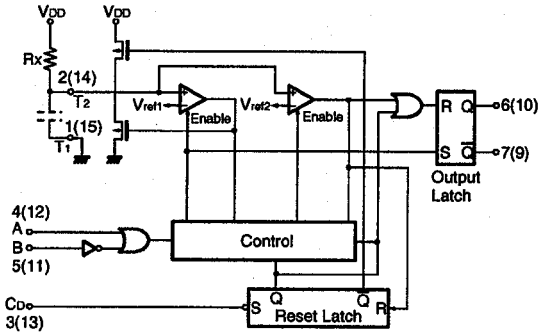
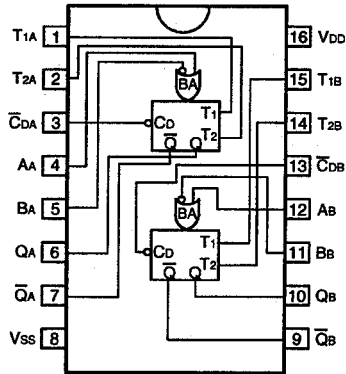
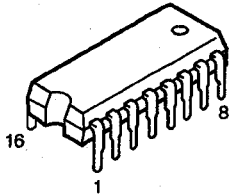

### NJM082D M5219P NJM2068D TL082CP

### TC4071BP

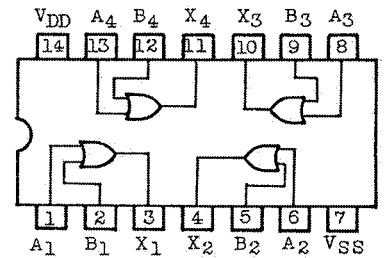
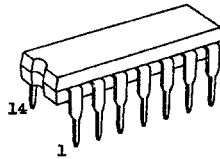
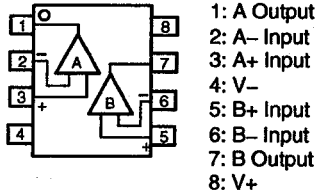
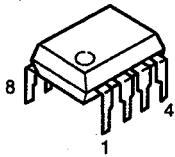

### LB1710 (Transistor Array)

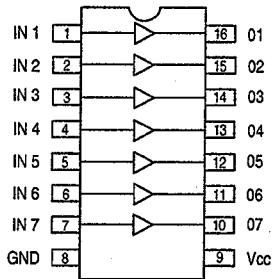
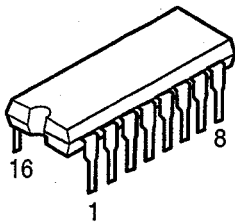

## 2. Transistor

**2SA933(S)**  
**2SC1740(S)**

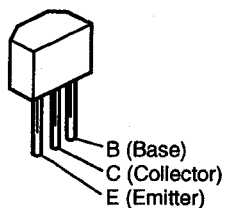

**2SD1111**  
**2SB888-AA**  
**2SC3792-AA**

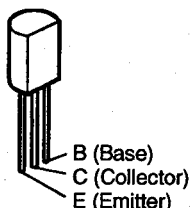

**2SA970(BL)**  
**2SA1015(GR),(GR/BL)**  
**2SC1815(GR),(GR/BL)**  
**2SC2240(BL)**

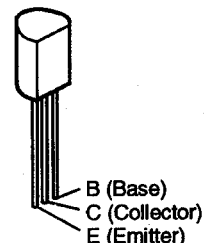

**2SA1837(Y)**  
**2SC4793(Y)**

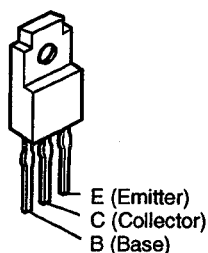

**2SB647A(C)**  
**2SD667A(C)**

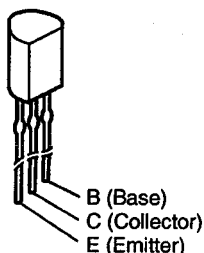

**2SA1358(O/Y)**  
**2SC3421(O/Y)**

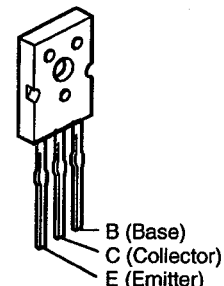

**2SK373(Y)**

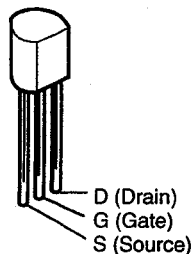

**2SK369(BL)/(GR)-C**  
**2SK170(BL)**  
**2SK170(V)**

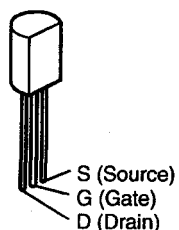

**2SK184C(GR)/(BL)**

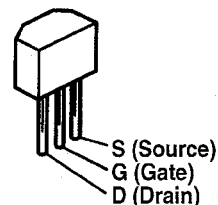

**2SJ216**

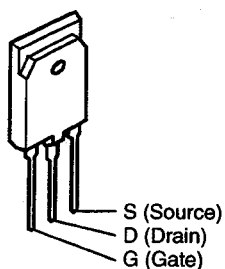

**2SK1303**

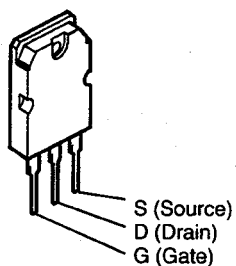

**2SB1383(P/Y)**  
**2SD2083(P/Y)**

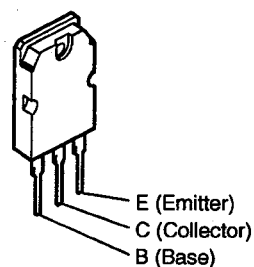



RN1202  
RN1204  
RN2202  
RN2204

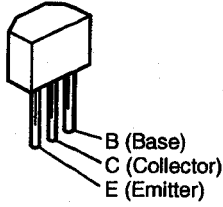

RN1202  
RN1204

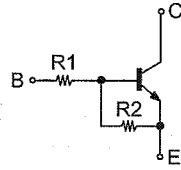

	R1	R2
RN1202	10kohm	10kohm
RN1204	47kohm	47kohm

RN2202  
RN2204

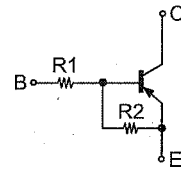

	R1	R2
RN2202	10kohm	10kohm
RN2204	47kohm	47kohm

### 3. Diode (Include LED)

FCH20A15

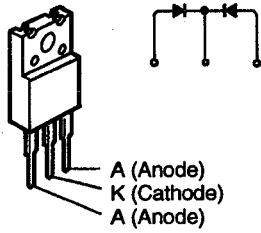

FRH20A15

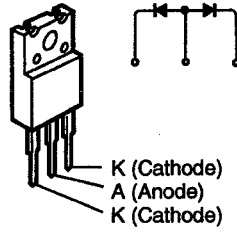

SWL1216W (LED)

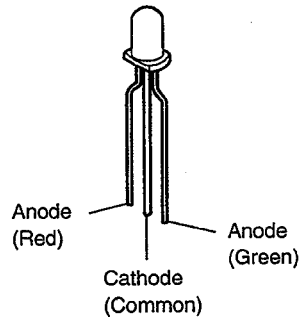

SFOR3G42 (Thyristor)

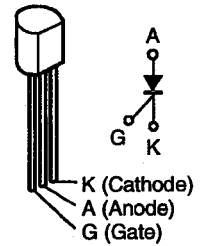

1SS270A

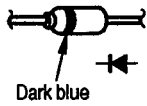

1SR35-400A

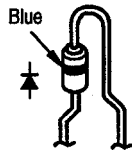

DA210S

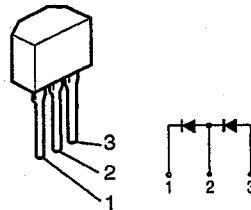

21DQ06

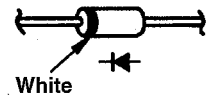

1S2076A

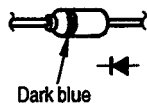

HZ12LA-1  
HZ16L-1  
HZ20L-2

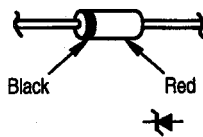

HZ4B-1  
HZ5C-1  
HZ12B-2

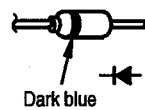

HZS2B-1  
HZS4A-1  
HZS6B-1  
HZS9A-1  
HZS12A-1  
MTZJ2.0A

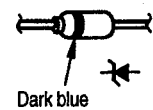



PRINTED WIRING BOARDS

1U-3658 INPUT/CONTROL P.W.B. UNIT

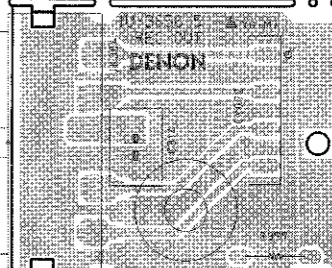
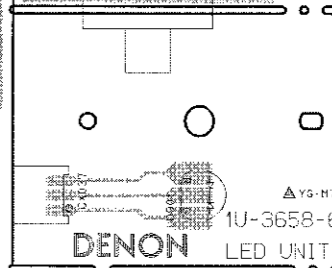
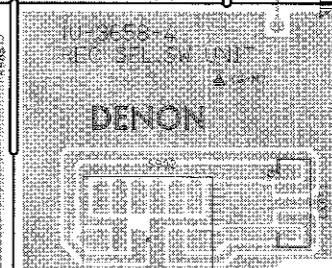
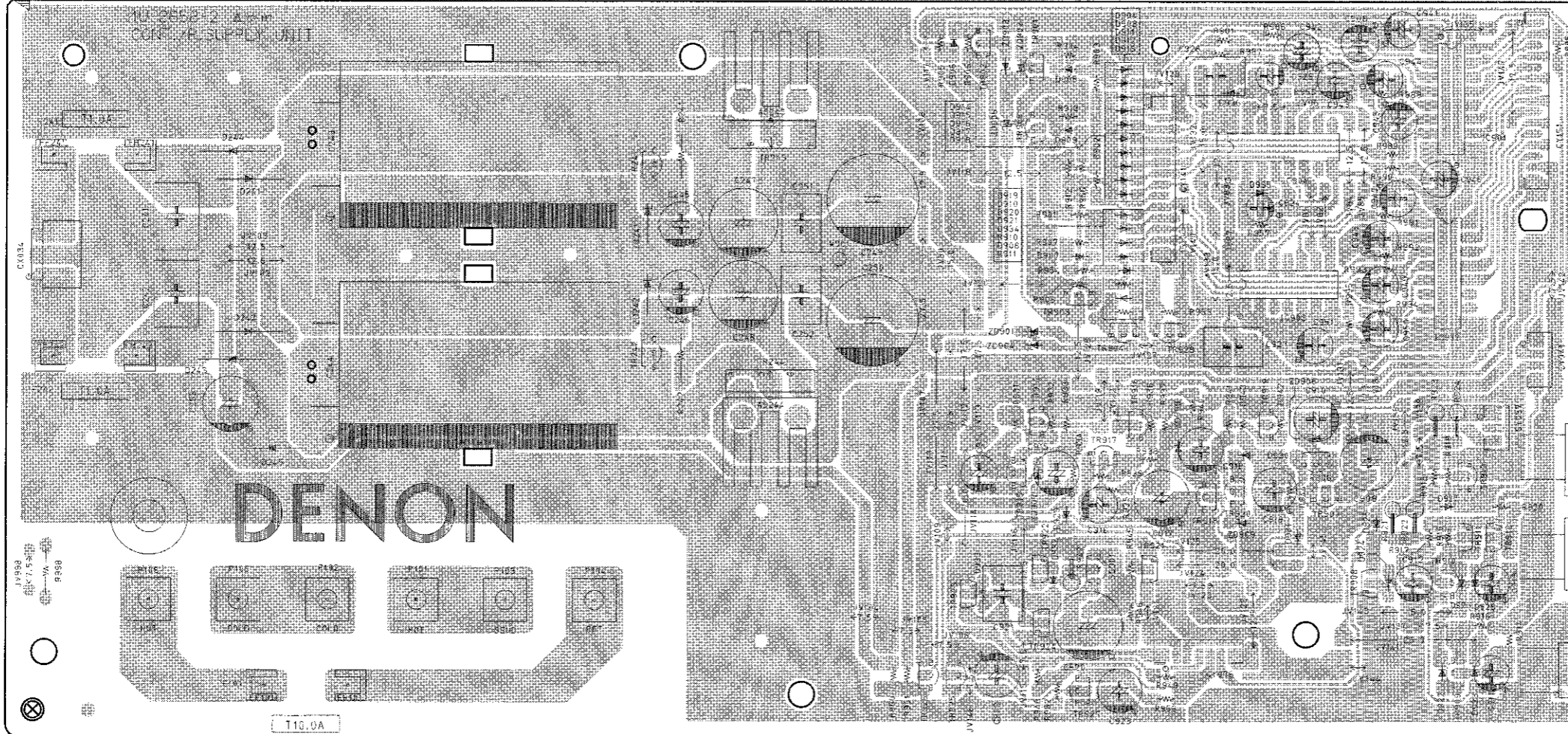
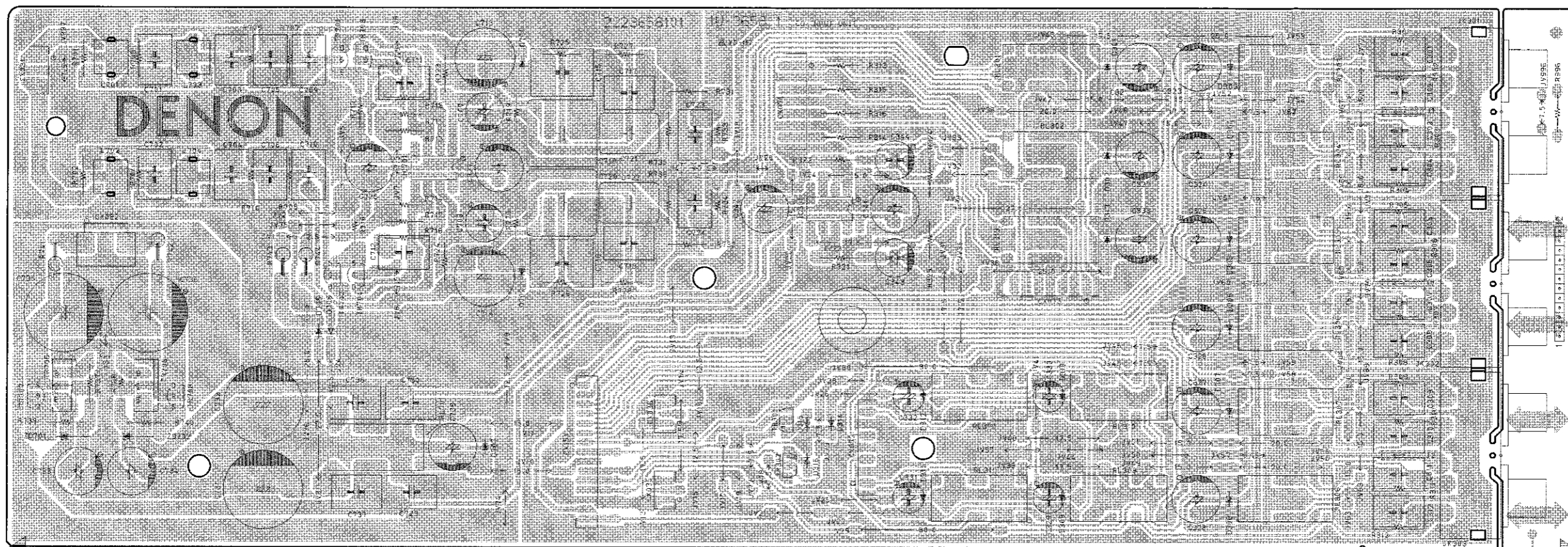

COMPONENT SIDE

1U-3659 POWER AMP P.W.B. UNIT

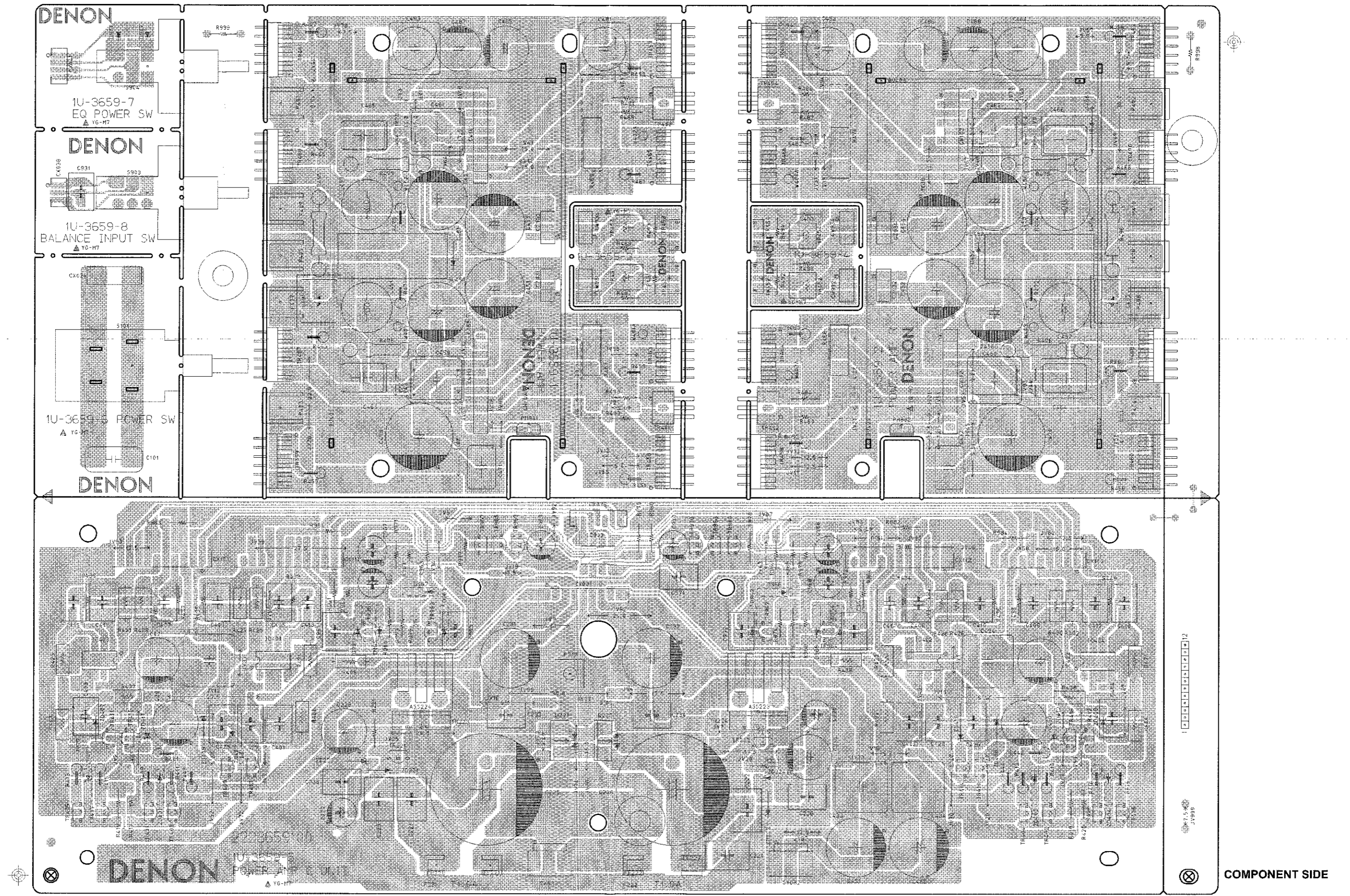

1U-3660 FUNCTION P.W.B. UNIT

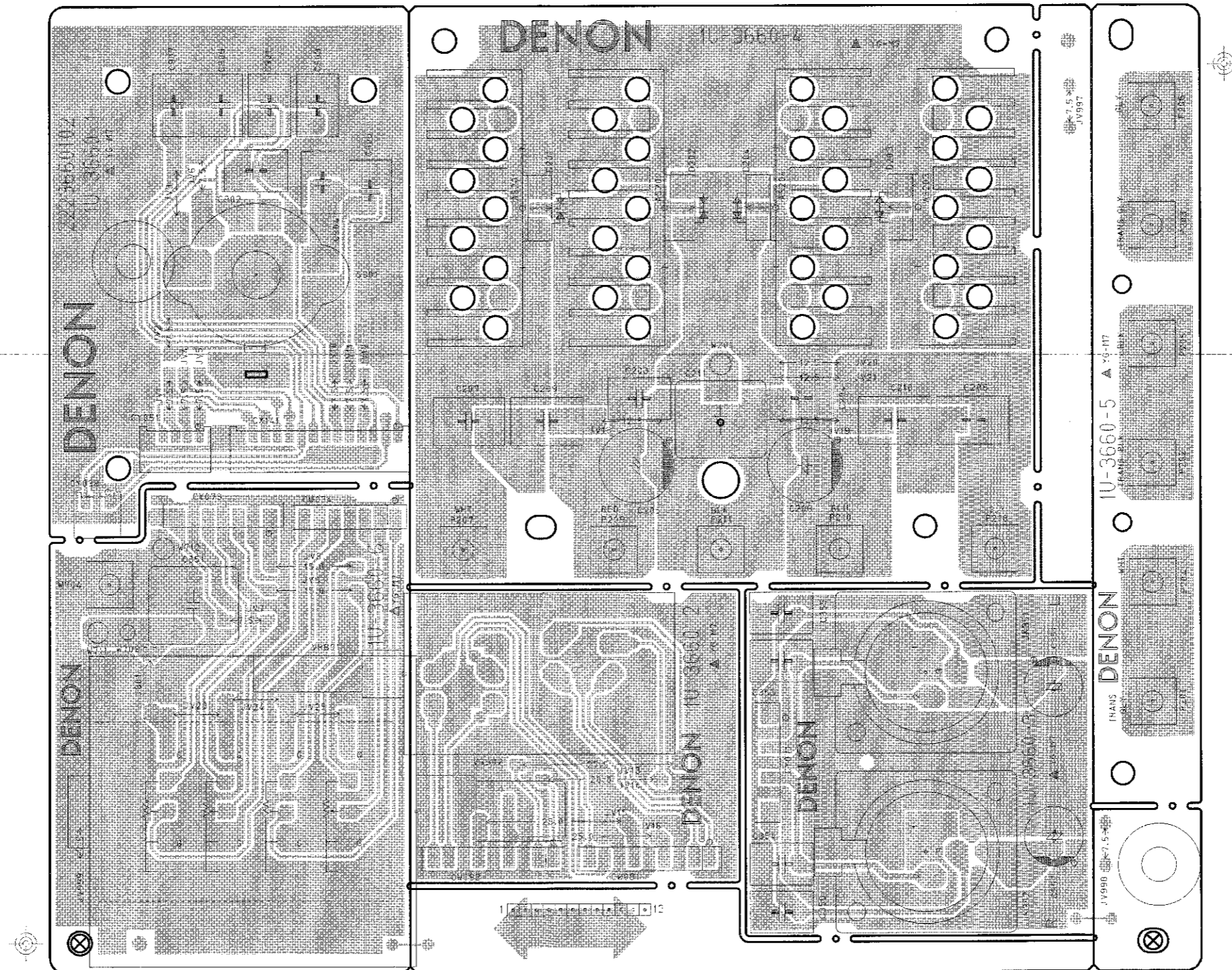

COMPONENT SIDE

KU-9284 DISTORTION AMP P.W.B. UNIT

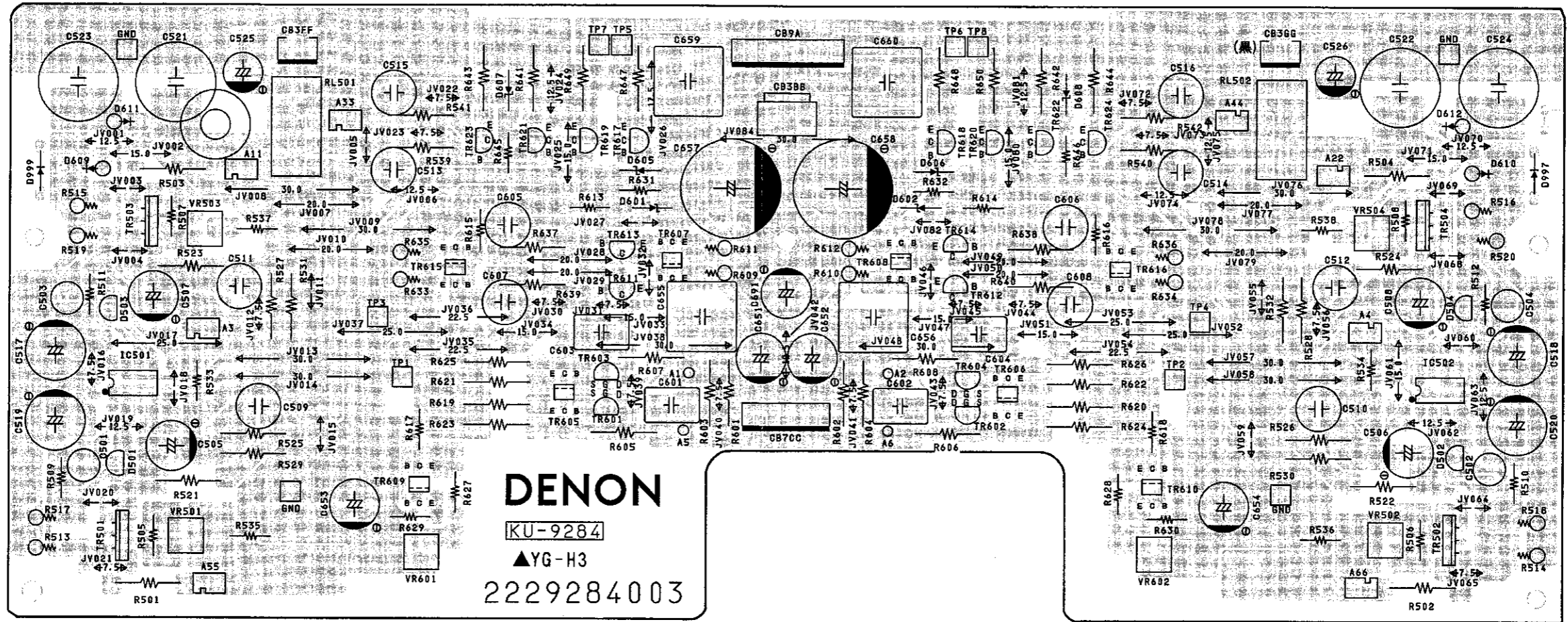

**DENON**  
KU-9284  
▲YG-H3  
2229284003

COMPONENT SIDE

# NOTE FOR PARTS LIST

- Part indicated with the mark "⊙" are not always in stock and possibly to take a long period of time for supplying, or in some case supplying of part may be refused.
  - When ordering of part, clearly indicate "I" and "I" (i) to avoid mis-supplying.
  - Ordering part without stating its part number can not be supplied.
  - Part indicated with the mark "★" is not illustrated in the exploded view.
  - Not including Carbon Film Resistor ±5%, 1/4W Type in the P.W.Board parts list. (Refer to the Schematic Diagram for those parts.)
  - Not including Carbon Chip Resistor 1/16W Type in the P.W.Board parts list. (Refer to the Schematic Diagram for those parts.)
- WARNING:**  
Parts marked with this symbol ⚠ have critical characteristics.  
Use ONLY replacement parts recommended by the manufacturer.

# 部品表について

- 印の部品は常時在庫していませんので供給に長時間を要することがあります。  
場合によっては、供給をお断りすることがあります。
- 部品を発注する際は特に数字の“1”と英字の“I”との区別をはっきり記入してください。
- 部品番号を表示していない部品は供給できません。
- ⚠印の部品は安全上重要な部品です。交換するときは、安全および性能維持のため必ず指定の部品をご使用ください。
- ★印のついている部品は分解図中には記載していません。
- カーボン抵抗器±5%、1/4W型は記載していません。定数は回路図を参照願います。
- カーボンチップ抵抗器1/16W型は記載していません。定数は回路図を参照願います。
- 部品表の抵抗器、コンデンサの品名記号の読み方は表を参照してください。

## ● Resistors

Ex.: RN 14K 2E 182 G ER

Type	Shape and performance	Power	Resist-ance	Allowable error	Others
RD : Carbon	2B : 1/8W	F : ±1%	P : Pulse-resistant type		
RC : Composition	2E : 1/4W	G : ±2%	NL : Low noise type		
RS : Metal oxide film	2H : 1/2W	J : ±5%	NB : Non-burning type		
RW : Winding	3A : 1W	K : ±10%	FR : Fuse-resistor		
RN : Metal film	3D : 2W	M : ±20%	F : Lead wire forming		
RK : Metal mixture	3F : 3W				
	3H : 5W				

### \* Resistance

1 8 2 ⇒ 1800 ohm = 1.8 kohm  
Indicates number of zeros after effective number.  
2-digit effective number.

Units: ohm

1 R 2 ⇒ 1.2 ohm  
1-digit effective number.  
2-digit effective number, decimal point indicated by R.  
Units: ohm

## ● 抵抗器

例) RN 14K 2E 182 G ER

種類	形状特性	電力	抵抗値	許容差	その他
RD : カーボン	2B : 1/8 W	F : ±1%	P : 耐パルス形		
RC : 固定体	2E : 1/4 W	G : ±2%	NL : 低雑音形		
RS : 金属系皮膜	2H : 1/2 W	J : ±5%	NB : 不燃形		
RW : 巻線	3A : 1 W	K : ±10%	FR : ヒューズ抵抗		
RN : 金属皮膜	3D : 2 W	M : ±20%	F : リード線成形		
RK : 金属混合体	3F : 3 W				
	3H : 5 W				

### \* 抵抗値

18 2 ⇒ 1800Ω=1.8kΩ  
有効数字につづく0の数を表わす。  
2桁の有効数字を表わす。

1R 2 ⇒ 1.2Ω  
1桁の有効数字を表わす。  
2桁の有効数字で小数点はRで表わす。  
単位はΩ

## ● Capacitors

Ex.: CE 04W 1H 2R2 M BP

Type	Shape and performance	Dielectric strength	Capacity	Allowable error	Others
CE : Aluminum foil electrolytic	0J : 6.3V	F : ±1%	HS : High stability type		
CA : Aluminum solid electrolytic	1A : 10V	G : ±2%	BP : Non-polar type		
CS : Tantalum electrolytic	1C : 16V	J : ±5%	HR : Ripple-resistant type		
CQ : Film	1E : 25V	K : ±10%	DL : For change and discharge		
CK : Ceramic	1V : 35V	M : ±20%	HF : For assuring high frequency		
CC : Ceramic	1H : 50V	Z : +80%	U : UL part		
CP : Oil	2A : 100V	-20%	C : CSA part		
CM : Mica	2B : 125V	+100%	W : UL-CSA type		
CF : Metallized	2C : 160V	-0%	F : Lead wire forming		
CH : Metallized	2D : 200V	C : ±0.25pF			
	2E : 250V	D : ±0.5pF			
	2H : 500V	= : Others			
	2J : 630V				

### \* Capacity (electrolyte only)

2 2 2 ⇒ 2200μF  
Indicates number of zeros after effective number.  
2-digit effective number.

Units: μF.

2 R 2 ⇒ 2.2μF  
1-digit effective number.  
2-digit effective number, decimal point indicated by R.  
Units: μF.

### \* Capacity (except electrolyte)

2 2 2 ⇒ 2200pF=0.0022μF  
(More than 2) Indicates number of zeros after effective number.  
2-digit effective number.

Units: pF.

2 2 1 ⇒ 220pF  
(0 or 1) Indicates number of zeros after effective number.  
2-digit effective number.

Units: pF.

● When the dielectric strength is indicated in AC, "AC" is included after the dielectric strength value.

## ● コンデンサ

例) CE 04W 1H 2R2 M BP

種類	形状特性	耐圧	容量	許容差	その他
CE : アルミ箔電解	0J : 6.3 V	F : ±1%	HS : 高安定形		
CA : アルミ固体電解	1A : 10 V	G : ±2%	BP : 無極性形		
CS : タンタル電解	1C : 16 V	J : ±5%	HR : 耐リップル形		
CQ : フィルム	1E : 25 V	K : ±10%	DL : 充放電対策用		
CK : セラミック	1V : 35 V	M : ±20%	HF : 高周波保証用		
CC : セラミック	1H : 50 V	Z : +80%	U : UL 部品		
CP : オイル	2A : 100 V	-20%	C : CSA 部品		
CM : マイカ	2B : 125 V	P : +100%	W : UL-CSA 部品		
CF : メタライズド	2C : 160 V	-0%	F : リード線成形		
CH : メタライズド	2D : 200 V	C : ±0.25pF			
	2E : 250 V	D : ±0.5pF			
	2H : 500 V	= : その他			
	2J : 630 V				

### \* 容量値

#### ● 電解コンデンサの場合

22 2 ⇒ 2200μF  
有効数字につづく0の数を表わす。  
2桁の有効数字を表わす。  
単位はμF

2R 2 ⇒ 2.2μF  
1桁の有効数字を表わす。  
2桁の有効数字で小数点はRで表わす。  
単位はμF

#### ● 電解コンデンサ以外の場合

22 2 ⇒ 2200pF=0.0022μF  
(0の数が2以上の場合)  
有効数字につづく0の数を表わす。  
2桁の有効数字を表わす。  
単位はpF

22 1 ⇒ 220pF  
(0の数が0または1の場合)  
有効数字につづく0の数を表わす。  
2桁の有効数字を表わす。  
単位はpF

● 耐圧を交流で表示する場合は、耐圧表示の次に「AC」を表示します。

## PARTS LIST OF P.W.B. UNIT

\*本表に記載されている部品は、補修用部品のため製品に使用している部品とは一部、形状、寸法などが異なる場合があります

## 00D1U-3658B INPUT/CONTROL P.W.B. UNIT ASS'Y

Ref. No.	Part No.	Part Name	Remarks	Q'ty	New
<b>SEMICONDUCTORS GROUP</b>					
	IC301	00D 263 0594 007	NJM2068DAC		
	IC701	00D 263 0244 001	NJM082D		
	IC901,902	00D 263 0917 008	LB1710		
	IC903	00D 262 0260 008	TC4071P		
	IC904	00D 262 2275 004	BU4538		
	TR241,242	00D 275 0060 903	2SK-170BL(TPE2)		
	TR243	00D 274 0190 003	2SD2083(P/Y)		
	TR244	00D 272 0152 003	2SB1383(P/Y)		
	TR301,302	00D 269 0029 907	RN1204(47K-47K)T		
	TR701-704	00D 275 0038 045	2SK369 (BL)/(GR)-C		
	TR705	00D 273 0442 004	2SC4793 (Y)		
	TR706	00D 271 0272 003	2SA1837-Y		
	TR707,708	00D 275 0042 905	2SK373(Y)TPE2		
	TR901-905	00D 273 0198 934	2SC1815(BL/GR)TPE2		
	TR906	00D 275 0042 905	2SK373(Y)TPE2		
	TR907	00D 273 0198 934	2SC1815(BL/GR)TPE2		
	TR908	00D 269 0025 901	RN1202(10K-10K)T		
	TR909,910	00D 273 0198 934	2SC1815(BL/GR)TPE2		
	TR911,912	00D 269 0030 909	RN2204(47K-47K)T		
	TR913	00D 273 0198 934	2SC1815(BL/GR)TPE2		
	TR914	00D 271 0102 924	2SA1015(GR)TPE2		
	TR915	00D 274 0111 901	2SD1111T (TAPE)		
	TR916	00D 271 0102 924	2SA1015(GR)TPE2		
	TR917,918	00D 274 0111 901	2SD1111T (TAPE)		
	TR919	00D 271 0102 924	2SA1015(GR)TPE2		
	TR920	00D 274 0111 901	2SD1111T (TAPE)		
	TR921-923	00D 269 0026 900	RN2202(10K-10K)T		
	TR924	00D 269 0025 901	RN1202(10K-10K)T		
	TR925	00D 273 0198 934	2SC1815(BL/GR)TPE2		
	TR926	00D 273 0379 902	2SC3792-AA (TAPE)		
	TR927,928	00D 273 0198 934	2SC1815(BL/GR)TPE2		
	D241-245	00D 276 0714 003	21DQ06		
	D301-316	00D 276 0432 903	1SS270A TE (TAPE)		
	D701,702	00D 276 0432 903	1SS270A TE (TAPE)		
	D705-707	00D 276 0432 903	1SS270A TE (TAPE)		
	D903-936	00D 276 0432 903	1SS270A TE (TAPE)		
	ZD241,242	00D 276 0255 928	HZ12B-2TE (TAPE)		
	ZD701,702	00D 276 0256 930	HZ16L-1TD (TAPE)		
	ZD902	00D 276 0450 901	HZS2B-1TD		
	ZD904	00D 276 0467 907	HZS9A-1TD		
	ZD905	00D 276 0473 904	HZS12A-1TD		
	ZD906	00D 276 0462 902	HZS6B-1TD		
	ZD907-909	00D 276 0455 906	HZS4A-1TD		
	LD901	00D 393 9645 009	SML1216W(D)		
	SC901	00D 279 0038 908	SF0R3G42 (TPE2)		



Ref. No.	Part No.	Part Name	Remarks	Q'ty	New
<b>RESISTORS GROUP</b>					
R241,242	00D 241 2422 944	RD14B2E102JT(PSNB)			
R301-316	00D 241 2428 980	RD14B2E474JT(PSNB)			
R321,322	00D 241 2422 944	RD14B2E102JT(PSNB)			
R323,324	00D 241 2427 923	RD14B2E104JT(PSNB)			
R707,708	00D 241 2426 940	RD14B2E473JT(PSNB)			
R709,710	00D 241 2420 988	RD14B2E221JT(PSNB)			
R711-714	00D 241 2423 927	RD14B2E222JT(PSNB)			
R715,716	00D 241 2421 961	RD14B2E471JT(PSNB)			
R717,718	00D 241 2423 985	RD14B2E392JT(PSNB)			
R719,720	00D 241 2415 919	RD14B2E470JT(PSNB)			
R725,726	00D 241 2425 983	RD14B2E273JT(PSNB)			
R727,728	00D 241 2423 927	RD14B2E222JT(PSNB)			
R731,732	00D 241 2420 988	RD14B2E221JT(PSNB)			
R733,734	00D 241 2421 961	RD14B2E471JT(PSNB)			
R735,736	00D 241 2428 948	RD14B2E334JT(PSNB)			
R739,740	00D 241 2422 944	RD14B2E102JT(PSNB)			
R743,744	00D 244 2058 032	RS14B3A470JNBS(RSFSV)			
R921-924	00D 244 2051 932	RS14B3A332JNBST(S)			
R947	00D 244 2051 974	RS14B3A102JNBST(S)			
R996-998	00D 241 2422 944	RD14B2E102JT(PSNB)			
<b>CAPACITORS GROUP</b>					
C241,242	00D 255 4257 938	CQ93P2A223JT(NH2)			
C243,244	00D 254 4558 032	CE04W1H332M(RFS)			
C245,246	00D 254 4557 936	CE04W1H100MT(RFS)			
C247,248	00D 254 4558 702	CE04W1H101MC(RFS)			
C249,250	00D 254 4558 757	CE04W1H331MC(RFS)			
C253	00D 254 4568 705	CE04W1H2R2MC(ARSA2)			
C321-328	00D 254 4557 949	CE04W1H220MT(RFS)			
C329,330	00D 254 4313 989	CE04W1H330MT(ASF)			
C333	00D 254 4557 949	CE04W1H220MT(RFS)			
C341,342	00D 254 4557 949	CE04W1H220MT(RFS)			
C343,344	00D 254 4313 950	CE04W1H101MT(ASF)			
C705,706	00D 255 4251 976	CQ93P2A101JT(NH2)			
C707,708	00D 254 4557 936	CE04W1H100MT(RFS)			
C709,710	00D 255 4251 976	CQ93P2A101JT(NH2)			
C711,712	00D 255 4255 972	CQ93P2A472JT(NH2)			
C713,714	00D 254 4558 702	CE04W1H101MC(RFS)			
C715,716	00D 255 4258 759	CQ93P2A393JFC(NH2)			
C717,718	00D 255 4253 974	CQ93P2A681JT(NH2)			
C719,720	00D 255 4259 732	CQ93P2A823JFC(NH2)			
C721,722	00D 255 4258 733	CQ93P2A333JFC(NH2)			
C723,724	00D 255 4255 972	CQ93P2A472JT(NH2)			
C725	00D 256 1066 002	CF93B1H105K(AKG)			
C727,728	00D 254 4557 907	CE04W1H010MT(RFS)			
C731,732	00D 254 4558 715	CE04W1H221MC(RFS)			
C733,734	00D 254 4557 949	CE04W1H220MT(RFS)			
C735,736	00D 254 4558 715	CE04W1H221MC(RFS)			
C737,738	00D 255 4256 955	CQ93P2A103JT(NH2)			
C739	00D 254 4557 952	CE04W1H470MT(RFS)			
C908	00D 254 4557 910	CE04W1H2R2MT(RFS)			
C909	00D 254 4557 952	CE04W1H470MT(RFS)			
C910	00D 254 4557 936	CE04W1H100MT(RFS)			
C911,912	00D 254 4557 910	CE04W1H2R2MT(RFS)			
C913	00D 254 4557 907	CE04W1H010MT(RFS)			
C914	00D 254 4557 910	CE04W1H2R2MT(RFS)			

Ref. No.	Part No.	Part Name	Remarks	Q'ty	New
C915	00D 254 4557 936	CE04W1H100MT(RFS)			
C916	00D 254 4557 907	CE04W1H010MT(RFS)			
C917-919	00D 254 4557 936	CE04W1H100MT(RFS)			
C920	00D 254 4558 702	CE04W1H101MC(RFS)			
C921	00D 256 1059 996	CF93A1H105JT(JL)			
C922,923	00D 254 4557 936	CE04W1H100MT(RFS)			
C924,925	00D 254 4313 921	CE04W1H220MT(ASF)			
C927,928	00D 255 4256 955	CQ93P2A103JT(NH2)			
C941	00D 254 4313 921	CE04W1H220MT(ASF)			
C942-951	00D 254 4557 910	CE04W1H2R2MT(RFS)			
<b>OTHERS PARTS GROUP</b>					
CX031	00D 205 0233 032	3P EH CONNECTOR BASE			
CX032	00D 205 0833 018	3P VH CON.BASE(BK)			
CX034	00D 205 0653 036	3P VH CON.BASE			
CX035	00D 205 0343 032	3P CONN.BASE(KR-PH)			
CX036	00D 205 0323 036	3P CONNE.BASE(BLK)			
CX037	00D 205 0395 035	3P KR CON BASE(L)RED			
CX051	00D 205 0343 058	5P CONN.BASE(KR-PH)			
CX071	00D 205 0278 071	7P EH CON BASE(BK)			
CX072	00D 205 0277 072	7P EH CON BASE (RD)			
CX073	00D 205 0233 074	7P EH CONNECTOR BASE			
CX151	00D 205 0375 055	15P CONN.BASE(KR-PH)			
CY031	00D 205 0233 032	3P EH CONNECTOR BASE			
CY037	00D 205 0321 038	3P CONNE.BASE(RED)			
CY041	00D 205 0343 045	4P CONN.BASE(KR-PH)			
CY072	00D 205 0277 072	7P EH CON BASE (RD)			
CY076	00D 205 0343 074	7P CONN.BASE(KR-PH)			
CY141	00D 205 0375 042	14P CONN.BASE(KR-PH)			
CY151	00D 205 0375 055	15P CONN.BASE(KR-PH)			
⚠	F101	00D 206 1015 090	FUSE (5A)		
⚠	F241,242	00D 206 1015 029	FUSE 1A T		
	FF101	00D 202 0040 909	FUSE CLIP(TAPE)		
	FF241,242	00D 202 0040 909	FUSE CLIP(TAPE)		
	FH101	00D 202 0040 909	FUSE CLIP(TAPE)		
	FH241,242	00D 202 0040 909	FUSE CLIP(TAPE)		
	JK301-304	00D 204 8548 001	4P PIN JACK(18MM)		
	JK701	00D 204 8549 000	2P PIN JACK(18MM)		
	P101-106	00D 205 0864 003	M3 SCREW TERMINAL		
	RL301-313	00D 214 0143 003	RELAY(RY-24W)		
	RL701	00D 214 0143 003	RELAY(RY-24W)		
	S902	00D 212 0380 006	ROTALY SW.(2-4)		
	W901	00D 203 0526 002	1P CONTACT ASS		
		00D 461 0415 007	RUBBER SHEET		
		00D 417 0476 023	RADIATOR		
		00D 471 3304 028	3X8 CBS-B		
		00D 513 3777 030	FUSE LABEL(5A)		for F101
		00D 513 3777 027	FUSE LABEL(1A)		for F241,242

00D1U-3659B POWER AMP P.W.B. UNIT ASS'Y

Ref. No.	Part No.	Part Name	Remarks	Q'ty	New
<b>SEMICONDUCTORS GROUP</b>					
IC401-404	00D 263 0219 007	TL082CP			
IC903	00D 262 0989 004	TLP521-2 (BL)			
TR221,222	00D 275 0060 916	2SK-170V(TPE2)			
TR223	00D 274 0190 003	2SD2083(P/Y)			
TR224	00D 272 0152 003	2SB1383(P/Y)			
TR401-404	00D 272 0053 908	2SB647A(C)TZ(TAPE)			
TR405-408	00D 274 0060 900	2SD667A(C)TZ(TAPE)			
TR409-412	00D 272 0171 903	2SB888-AA			
TR413-416	00D 274 0111 901	2SD1111T (TAPE)			
TR451-454	00D 273 0323 000	2SC3421 O/Y			
TR455-470	00D 205 1230 063	6P PIN HEADER(6035)			
TR961-968	00D 273 0198 921	2SC1815(GR)TPE2			
TR969,970	00D 271 0102 924	2SA1015(GR)TPE2			
D221	00D 276 0706 008	FCH20A15			
D222	00D 276 0707 007	FRH20A15			
D451,452	00D 276 0049 914	1S2076ATE (TAPE)			
D901,902	00D 276 0432 903	1SS270A TE (TAPE)			
D961-968	00D 276 0432 903	1SS270A TE (TAPE)			
ZD221-224	00D 276 0347 904	HZ12LA-1TD(TAPE)			
ZD401-404	00D 276 0624 902	MTZJ2.0A T77			
ZD405-412	00D 276 0236 934	HZ5C-1TE(TAPE)			
PH901,902	00D 279 0034 067	PTH9M04BB222TS2F333			
<b>RESISTORS GROUP</b>					
R221,222	00D 241 2422 944	RD14B2E102JT(PSNB)			
R401-404	00D 241 2450 796	RD05A2H105JF(RMG)			
R405-408	00D 241 2434 767	RD05A2H102JF(RMG)			
R409-416	00D 244 2068 006	RS14B3A101JNBS RSFSV			
R417,418	00D 241 2422 944	RD14B2E102JT(PSNB)			
R419,420	00D 241 2425 925	RD14B2E153JT(PSNB)			
R421-424	00D 241 2434 712	RD05A2H101J(RMG)F			
R425-432	00D 241 2438 721	RD05A2H222JF (RMG)			
R433-440	00D 241 2423 927	RD14B2E222JT(PSNB)			
R441-444	00D 244 2058 061	RS14B3A100JNBS(RSFSV)			
R451-466	00D 244 2058 061	RS14B3A100JNBS(RSFSV)			
R467-470	00D 244 2067 010	RS14B3D0R1JNBF RSFKL			
R471-474	00D 244 2058 045	RS14B3A4R7JNBS(RSFSV)			
R475-478	00D 244 2067 007	RS14B3D100JNBF RSFKL			
R479-486	00D 241 2424 984	RD14B2E103JT(PSNB)			
R487-490	00D 241 2423 985	RD14B2E392JT(PSNB)			
R491-494	00D 241 2422 944	RD14B2E102JT(PSNB)			
R495,496	00D 244 2067 007	RS14B3D100JNBF RSFKL			
R961-964	00D 241 2423 985	RD14B2E392JT(PSNB)			
R965-968	00D 241 2424 968	RD14B2E822JT(PSNB)			
R969-972	00D 241 2426 937	RD14B2E433JT(PSNB)			
R973-976	00D 241 2424 984	RD14B2E103JT(PSNB)			
R977,978	00D 241 2425 909	RD14B2E123JT(PSNB)			
R979	00D 241 2422 944	RD14B2E102JT(PSNB)			
R980	00D 241 2425 967	RD14B2E223JT(PSNB)			

Ref. No.	Part No.	Part Name	Remarks	Q'ty	New
R981-984	00D 241 2426 908	RD14B2E333JT(PSNB)			
R998,999	00D 241 2424 984	RD14B2E103JT(PSNB)			
VR451-454	00D 211 6075 037	V06PB103 (CERMET)			
<b>CAPACITORS GROUP</b>					
C101	00D 253 8022 707	CK45F2EAC103MC			
C101	00D 415 0299 000	CONDENSER COVER			
C221-224	00D 255 4257 938	CQ93P2A223JT(NH2)			
C225,226	00D 254 4445 763	CE04W1H332MC(ARSG)			
C227,228	00D 254 4557 936	CE04W1H100MT(RFS)			
C229,230	00D 254 4558 702	CE04W1H101MC(RFS)			
C231,232	00D 254 4672 714	CE04W1H471MC(RGO)			
C235,236	00D 255 4256 955	CQ93P2A103JT(NH2)			
C401-404	00D 255 4250 977	CQ93P2A390JT(NH2)			
C405-412	00D 255 4252 933	CQ93P2A181JT(NH2)			
C413-416	00D 255 4250 964	CQ93P2A330JT(NH2)			
C421,422	00D 254 4644 700	CE04W1H101MC(RGO)			
C423,424	00D 255 6188 005	CQ09S2B103J(PPSC)			
C425-428	00D 255 4255 972	CQ93P2A472JT(NH2)			
C429,430	00D 254 4417 018	CE04W1H4R7M(ARSA)			
C431,432	00D 254 4672 714	CE04W1H471MC(RGO)			
C433,434	00D 255 6188 005	CQ09S2B103J(PPSC)			
C451-458	00D 254 4672 701	CE04W1H221MC(RGO)			
C459-462	00D 256 1054 001	CF93B1H105K(GSG) )			
C463-466	00D 256 8036 006	CF93B2E104K(WAG)			
C471,472	00D 256 8036 006	CF93B2E104K(WAG)			
C473,474	00D 254 4671 760	CE04W1J471MC(RGO#5)			
C481-484	00D 255 6188 005	CQ09S2B103J(PPSC)			
C485-488	00D 254 4644 700	CE04W1H101MC(RGO)			
C491,492	00D 255 4259 716	CQ93P2A683JFC(NH2)			
C961-964	00D 255 4255 914	CQ93P2A272JT(NH2)			
C965-968	00D 254 4557 936	CE04W1H100MT(RFS)			
C969,970	00D 254 4368 947	CE04W1E221MT(ASF)			
C971	00D 255 4256 955	CQ93P2A103JT(NH2)			
<b>OTHERS PARTS GROUP</b>					
BU401-404	00D 412 5202 006	COMMON PLATE			
BU405,406	00D 412 5202 019	COMMON PLATE			
CW101,102	00D 204 2985 000	10P EH-SCN CON.CORD			
CW111,112	00D 204 6783 004	11P EH-SCN CON.CORD			
CW931-934	00D 203 5179 030	3P SCN-SCN CON.CORD			
CX021	00D 205 0606 025	2P WRAPPING TERMINAL			
CX033	00D 205 0833 005	3P VH CON.BASE(RD)			
CX038	00D 205 0406 034	3P CON BASE(KR-PH)			
CX041	00D 205 0343 045	4P CONN.BASE(KR-PH)			
CX076	00D 205 0343 074	7P CONN.BASE(KR-PH)			
CX091	00D 205 0278 097	9P EH CON BASE (BK)			
CX101,102	00D 205 0275 003	10P EH CON. BASE			
CX111,112	00D 205 0275 016	11P EH CONN. BASE			
CY032	00D 205 0833 018	3P VH CON.BASE(BK)			

	Ref. No.	Part No.	Part Name	Remarks	Q'ty	New
⚠	F221,222	00D 206 1015 029	FUSE 1A T			
	FF221,222	00D 202 0040 909	FUSE CLIP(TAPE)			
	FH221,222	00D 202 0040 909	FUSE CLIP(TAPE)			
	L451-454	00D 235 0179 003	INDUCTOR(RB1R0)			
	P212	00D 205 0864 003	M3 SCREW TERMINAL			
	P401-410	00D 205 1034 023	M3 SCREW TERMINAL			
	RL451,452	00D 214 0129 001	RELAY(DH2TU)			
⚠	S101	00D 212 2609 002	POWER SWITCH(SDDF)			
	S903,904	00D 212 2615 012	1P PUSH SWITCH			
	TP401-404	00D 205 0154 030	3P NH CONNECTOR BASE			
	W401-404	00D 203 0668 009	1P CON. ASS'Y			
		00D 415 0309 042	PVC TUBE(L=05)			
		00D 415 0408 105	PVC TUBE(L=30)			
		00D 417 0476 036	RADIATOR			
		00D 471 3304 028	3X8 CBS-B			
		00D 513 3777 027	FUSE LABEL(1A)	for F221,222		

00D1U-3660 FUNCTION SW P.W.B. UNIT ASS'Y

Ref. No.	Part No.	Part Name	Remarks	Q'ty	New
<b>SEMICONDUCTORS GROUP</b>					
D201,202 D203,204	00D 276 0706 008 00D 276 0707 007	FCH20A15 FRH20A15			
<b>RESISTORS GROUP</b>					
* VR801 VR802	00D 211 5656 004 00D 211 5657 003	V5040V30SA104 V2740V20F=104K(MN)	MAIN VOLUME BALANCE VOLUME		
<b>CAPACITORS GROUP</b>					
C203,204 C205,206 C207-210 C351,352	00D 255 6188 005 00D 254 4568 705 00D 255 4257 938 00D 254 4557 949	CQ09S2B103J(PPSC) CE04W1H2R2MC(ARSA2) CQ93P2A223JT(NH2) CE04W1H220MT(RFS)			
C353-356 C901-907	00D 255 4251 976 00D 255 4254 915	CQ93P2A101JT(NH2) CQ93P2A102JT(NH2)			
<b>OTHERS PARTS GROUP</b>					
CW074 CW091 CW092 CX141	00D 204 2678 029 00D 204 2984 001 00D 204 2682 015 00D 205 0480 047	7P NH-SCN CON.CORD 9P EH-SCN CON.CORD 9P NH-SCN CON.CORD 14P KR CON BASE(L)			
CY038 CY051 CY071 CY073	00D 205 0686 032 00D 205 0355 059 00D 205 0278 071 00D 205 0233 074	3P CON.BASE(BLU)L 5P KR CON BASE(L) 7P EH CON BASE(BK) 7P EH CONNECTOR BASE			
JK351,352 P201-211	00D 205 0634 000 00D 205 0864 003	3P CANNON CONNECTOR M3 SCREW TERMINAL			
S901 W709 W711	00D 212 0357 000 00D 203 0526 073 00D 203 0535 006	ROTARY SW.(1-7) 1P CONTACT ASS 1P SIN CON ASS'Y			
	00D 417 0680 000 00D 471 3304 028	RADIATOR 3X8 CBS-B			

\*メインボリューム (VR801) には素手で触れないでください。  
誤って触れた場合には乾いた布で指紋をふきとってください。

\* DO NOT touch the Main Volume (VR801) with bare hand.  
If you touch it inevitably, wipe out the finger marks with dry cloth.

## 00DKU-9284T DISTORTION AMP P.W.B. UNIT ASS'Y

Ref. No.	Part No.	Part Name	Remarks	Q'ty	New
<b>SEMICONDUCTORS GROUP</b>					
IC501,502	00D 263 0284 003	M5219P			
TR501-508	00D 275 0055 015	2SK184C (GR)/(BL)			
TR601-604	00D 275 0055 015	2SK184C (GR)/(BL)			
TR605,606	00D 273 0187 916	2SC2240(BL)TPE2			
TR607,608	00D 271 0094 919	2SA970(BL)TPE2			
TR609,610	00D 273 0187 916	2SC2240(BL)TPE2			
TR611-614	00D 271 0102 924	2SA1015(GR)TPE2			
TR615,616	00D 273 0187 916	2SC2240(BL)TPE2			
TR617-624	00D 274 0060 900	2SD667A(C)TZ(TAPE)			
TR625,626	00D 271 0094 919	2SA970(BL)TPE2			
TR627-632	00D 273 0187 916	2SC2240(BL)TPE2			
D501-504	00D 276 0630 909	DA210S TP			
D601,602	00D 276 0624 902	MTZJ2.0A T77			
D605,606	00D 276 0313 938	HZ20L-2TD(TAPE)			
D607,608	00D 276 0185 933	HZ4B-1TE(TAPE)			
D609-612	00D 276 0704 903	1SR35-400A(T93X)			
<b>RESISTORS GROUP</b>					
R501-504	00D 241 2438 006	RD05A2H301J(RMG)			
R505-508	00D 241 2420 904	RD14B2E101JT(PSNB)			
R509-512	00D 241 2421 961	RD14B2E471JT(PSNB)			
R513-520	00D 244 2068 080	RS14B3A471JNBF RSFSV			
R521-524	00D 241 2450 738	RD05A2H514JF(RMG)			
R525-528	00D 241 2425 996	RD14B2E303JT(PSNB)			
R529,530	00D 241 2438 006	RD05A2H301J(RMG)			
R531,532	00D 241 2434 013	RD05A2H151J(RMG)			
R535-538	00D 241 2424 926	RD14B2E562JT(PSNB)			
R539-542	00D 241 2438 763	RD05A2H472J(RMG)F			
R591	00D 241 2438 006	RD05A2H301J(RMG)			
R592	00D 241 2438 006	RD05A2H301J(RMG)			
R601-604	00D 241 2449 707	RD05A2H154JF(RMG)			
R605-608	00D 241 2434 767	RD05A2H102JF(RMG)			
R609-612	00D 244 2068 051	RS14B3A121JNBS RSFSV			
R613,614	00D 241 2422 944	RD14B2E102JT(PSNB)			
R615,616	00D 241 2425 925	RD14B2E153JT(PSNB)			
R617,618	00D 241 2422 944	RD14B2E102JT(PSNB)			
R619-622	00D 241 2438 006	RD05A2H301J(RMG)			
R623-626	00D 241 2448 766	RD05A2H104JF(RMG)			
R627,628	00D 241 2417 962	RD14B2E100JT(PSNB)			
R629,630	00D 241 2421 903	RD14B2E271JT(PSNB)			
R631,632	00D 241 2423 927	RD14B2E222JT(PSNB)			
R633-636	00D 244 2068 077	RS14B3A241JNBS RSFSV			
R637-640	00D 241 2425 996	RD14B2E303JT(PSNB)			
R641-644	00D 244 2068 064	RS14B3A221JNBS RSFSV			
R645,646	00D 241 2426 940	RD14B2E473JT(PSNB)			
R647-650	00D 241 2438 721	RD05A2H222JF (RMG)			
VR501-504	00D 211 6075 011	V06PB101 (CERMET)			
VR601,602	00D 211 6075 011	V06PB101 (CERMET)			

Ref. No.	Part No.	Part Name	Remarks	Q'ty	New
<b>CAPACITORS GROUP</b>					
C501-504	00D 255 4253 932	CQ93P2A471JT(NH2)			
C505-508	00D 254 4672 727	CE04W1H470MC(RGO)			
C509-512	00D 255 6181 028	CQ09S2G330KF(B)			
C513-516	00D 255 6181 015	CQ09S2G220KF(B)			
C517-520	00D 254 4672 727	CE04W1H470MC(RGO)			
C521-524	00D 255 6188 005	CQ09S2B103J(PPSC)			
C525,526	00D 254 4557 952	CE04W1H470MT(RFS)			
C601-604	00D 255 4250 993	CQ93P2A470JT(NH2)			
C605,606	00D 255 4250 906	CQ93P2A100JT(NH2)			
C607,608	00D 255 4250 948	CQ93P2A220JT (NH2)			
C651,652	00D 254 4557 936	CE04W1H100MT(RFS)			
C653,654	00D 254 4417 018	CE04W1H4R7M(ARSA)			
C655,656	00D 255 6188 005	CQ09S2B103J(PPSC)			
C657,658	00D 254 4672 701	CE04W1H221MC(RGO)			
C659,660	00D 255 6188 005	CQ09S2B103J(PPSC)			
<b>OTHERS PARTS GROUP</b>					
A011	00D 203 2358 016	2P SCN-SIN CON.CORD			
A022	00D 203 2358 003	2P SCN-SIN CON.CORD			
A033	00D 203 2362 015	2P SCN-SCN CON.CORD			
A044	00D 203 2362 002	2P SCN-SCN CON.CORD			
A055	00D 203 2358 016	2P SCN-SIN CON.CORD			
A066	00D 203 2358 003	2P SCN-SIN CON.CORD			
CX074	00D 205 0190 078	7P NH CONNECTOR BASE			
CX092	00D 205 0190 094	9P NH CONNECTOR BASE			
CY035	00D 205 0343 032	3P CONN.BASE(KR-PH)			
CY036	00D 205 0323 036	3P CONNE.BASE(BLK)			
RL501,502	00D 214 0143 003	RELAY(RY-24W)			
	00D 125 9002 078	UL TUBE (L=30)	for R591,592		
	00D 461 0415 007	RUBBER SHEET	for R591,592		



# EXPLODED VIEW

## Parts List

**WARNING:**  
 Parts marked with this symbol  have critical characteristics.  
 Use **ONLY** replacement parts recommended by the manufacturer.

印の部分は安全を維持するために重要な部品です。従って交換時は必ず指定の部品を使用してください。

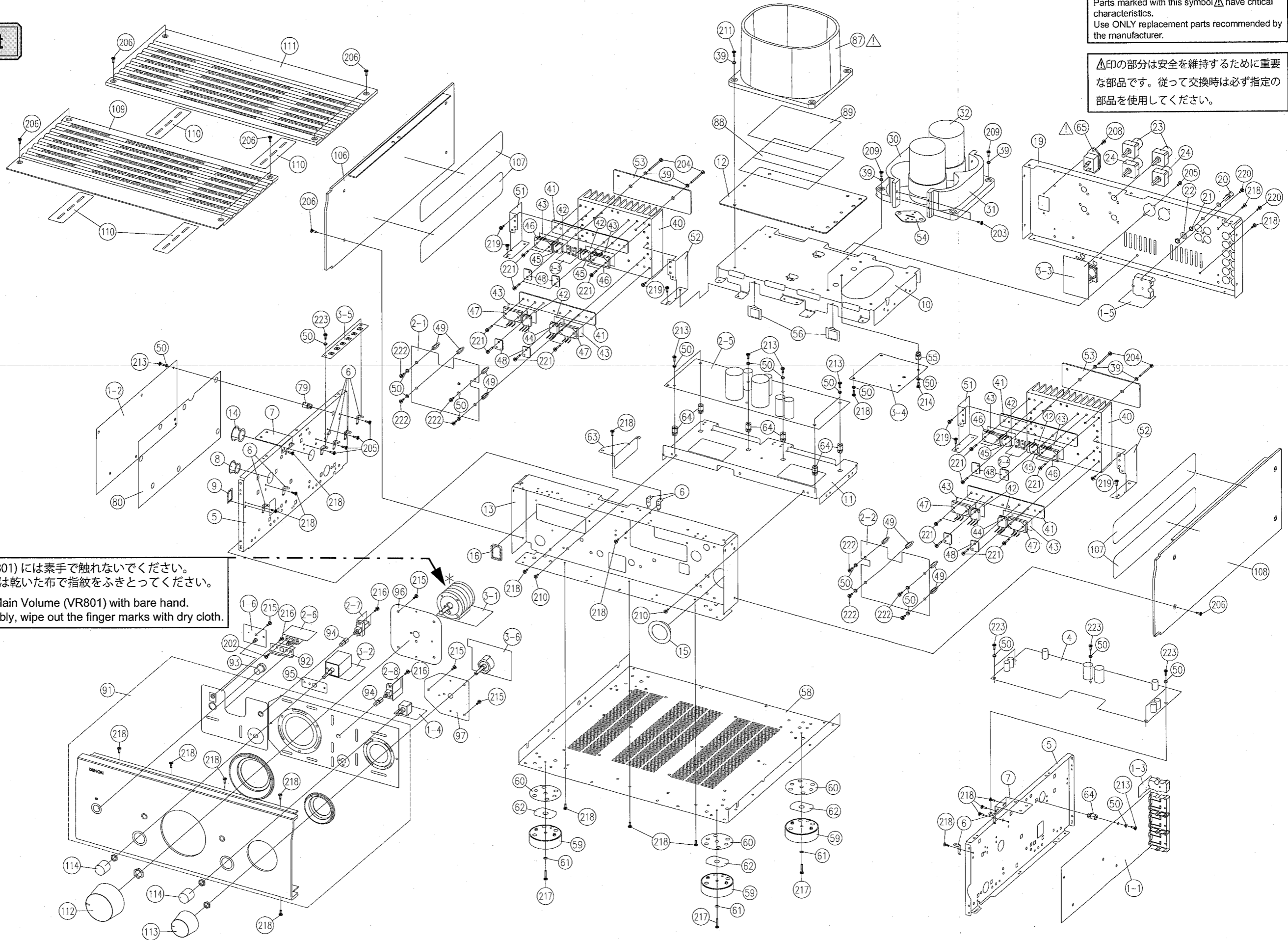

\*メインボリューム (VR801) には素手で触れないでください。  
 誤って触れた場合には乾いた布で指紋をふきとってください。  
 \* DO NOT touch the Main Volume (VR801) with bare hand.  
 If you touch it inevitably, wipe out the finger marks with dry cloth.

## PARTS LIST OF EXPLODED VIEW

\*本表に記載されている部品は、補修用部品のため製品に使用している部品とは一部、形状、寸法などが異なる場合があります。

Ref. No.	Part No.	Part Name	Remarks	Q'ty	New
1	00D1U-3658B	INPUT/CONTROL UNIT ASS'Y		1	*
1-1		INPUT UNIT			
1-2		CONTROL UNIT			
1-3		PHONO INPUT UNIT			
1-4		REC SEL. SW UNIT			
1-5		REC OUT UNIT			
1-6		LED UNIT			
2	00D1U-3659B	POWER AMP UNIT ASS'Y		1	*
2-1		POWER AMP L UNIT			
2-2		POWER AMP R UNIT			
2-3		MULTIPLYER L UNIT			
2-4		MULTIPLYER R UNIT			
2-5		POWER AMP C UNIT			
2-6		POWER SW UNIT			
2-7		EQ POWER SW UNIT			
2-8		BALANCE INPUT SW UNIT			
3	00D1U-3660	FUNCTION SW UNIT ASS'Y		1	*
3-1		FUNCTION SW UNIT			
3-2		BALANCE VOLUME UNIT			
3-3		BALANCED INPUT UNIT			
3-4		DIODE UNIT			
3-5		TERMINAL UNIT			
3-6		MAIN VOLUME UNIT			
4	00DKU-9284T	DISTORTION AMP UNIT ASS'Y		1	
5	00D 414 1013 004	SHIELD PLATE		2	*
6	00D 412 5201 007	PWB BRACKET(B)		10	*
7	00D 411 2077 105	JOINT BRACKET		2	*
8	00D 462 0089 025	BUSH		3	
9	00D 415 0469 076	FLEXIBLE BUSH		1	*
10	00D 411 2081 007	TRANS CHASSIS		1	*
11	00D 411 2078 007	PWB CHASSIS		1	*
12	00D 412 5204 004	TRANS PLATE		1	*
13	00D 411 2079 006	FRONT CHASSIS		1	*
14	00D 462 0089 038	BUSH		1	*
15	00D 462 0089 054	BUSH		1	
16	00D 415 0469 089	FLEXIBLE BUSH		1	*
★ 17	00D 445 0048 016	CORD HOLDER (L50)		1	
★ 18	00D 445 0048 003	CORD HOLDER (L76)		3	
19	00D 105 1474 118	BACK PANEL		1	*
20	00D 205 0879 001	GND TERMINAL		1	
21	00D 475 3204 007	6 TW-B		1	
22	00D 475 1007 002	6 W ZN		1	
23	00D 205 1281 009	1P SP TERMINAL RD		2	*
24	00D 205 1282 008	1P SP TERMINAL WH		2	*
★ 25	00D 203 0747 001	1P CON.ASS'Y	P-407	1	
★ 26	00D 203 0747 014	1P CON.ASS'Y	P-408	1	
★ 27	00D 203 0747 027	1P CON.ASS'Y	P-410	1	
★ 28	00D 203 0747 030	1P CON.ASS'Y	P-409	1	
★ 29	00D 415 0496 007	UL TUBE(12.7)BK		3	
30	00D 443 1600 004	C-HOLD BASE(A)		1	*
31	00D 443 1602 002	C-HOLD BASE(B)		1	*
32	00D 254 6246 009	CE33W1H123M		2	*
★ 33	00D 203 0666 014	1P CON. ASS'Y	P-209	1	
★ 34	00D 203 0666 001	1P CON. ASS'Y	P-210	1	

	Ref. No.	Part No.	Part Name	Remarks	Q'ty	New
	★ 35	00D 203 2391 002	2P CON. ASSY	P-401P-402	1	
	★ 36	00D 203 2391 015	2P CON. ASSY	P-403P-404	1	
	★ 37	00D 203 2392 056	2P CON. ASS'Y	P-405P-406	1	
	★ 38	00D 203 2392 043	2P CON. ASS'Y	P-211P-212	1	
	39	00D 415 0809 005	WASHER		12	
	40	00D 417 0675 002	POWER RADIATOR		2	*
	41	00D 417 0674 003	CU PLATE		4	*
	42	00D 415 0234 007	INSULATING SHEET		8	
	43	00D 415 9044 007	INSULATING SHEET		8	
	44	00D 275 0080 006	2SJ216		4	
	45	00D 275 0081 005	2SK1303		4	
	46	00D 274 0170 007	2SD2401		4	
	47	00D 272 0134 005	2SB1570		4	
	48	00D 417 0542 009	CU PLATE (B)		8	
	49	00D 443 1596 024	SCREW POST		8	*
	50	00D 415 0947 006	BUSH		35	
	51	00D 411 2074 001	RADIATOR BRACKET(A)		2	*
	52	00D 411 2075 000	RADIATOR BRACKET(B)		2	*
	53	00D 411 2073 002	PLATE(RD)		2	*
	54	00D 412 5203 005	COMMON PLATE(A)		1	*
	55	00D 443 9015 002	P.W. SPACER		2	
	56	00D 445 0095 001	WIRE HOLDER		2	
	58	00D 105 1473 009	BOTTOM COVER		1	*
	59	00D 104 0331 107	FOOT ASS'Y		4	
	60	00D 129 0212 005	FOOT DAMPER		4	
	61	00D 415 9080 003	TEFLON SPACER		4	
	62	00D 129 0268 004	SILK SHEET(FOOT)		4	
	63	00D 411 2080 008	PWB BRACKET(A)		1	*
⚠	★ 64	00D 412 3548 005	P.W.B CATCHER		12	
	65	00D 203 3996 008	AC INLET (2P)		1	
	★ 66	00D 009 9046 017	1P(F3)CORD ASS'Y	P-101	1	
	★ 67	00D 009 9046 020	1P(F3)CORD ASS'Y	P-102	1	
	★ 68	00D 203 5360 001	3P EH-EH CON.CORD	CN031	1	
	★ 69	00D 203 4964 068	3P VH-VH CONN CORD	CN032	1	
	★ 70	00D 203 4872 095	3P KR-KR RIBBON 500	CN035	1	
	★ 71	00D 203 4872 011	3P KR-KR RIBBON 300	CN036,037	1	
	★ 72	00D 415 0364 074	UL TUBE	CN035,036	1	
	★ 73	00D 204 2983 002	7P EH-EH CON.CORD	CN071	1	
	★ 74	00D 204 2983 028	7P EH-EH CON.CORD	CN072	1	
	★ 75	00D 204 6364 041	15P KR-KR RIBBON 750	CN151	1	
	★ 76	00D 415 0680 059	SPACER		1	
	★ 77	00D 461 1012 030	RUBBER FOAM		1	
	★ 78	00D 204 2544 014	7P KR-KR RIBBON 300	CN076	1	
	79	00D 412 2762 002	P.W.B.HOLDER	L=12	6	
	80	00D 414 1025 102	PROTECT SHEET		1	*
	★ 81	00D 412 2814 057	CARD SPACER (L=12)		1	
	★ 82	00D 445 0128 004	CLAMP BAND		2	
	★ 83	00D 203 0748 000	1P CON.ASS'Y	P-204	1	
	★ 84	00D 203 0748 013	1P CON.ASS'Y	P-206	1	
	★ 85	00D 203 0748 026	1P CON.ASS'Y	P-205	1	
	★ 86	00D 412 2814 028	CARD SPACER(L=10)		2	
⚠	87	00D 233 6512 008	POWER TRANS UNIT(E2)		1	*
	88	00D 415 0877 024	DAMP SHEET(A)		2	*
	89	00D 129 0266 006	SILK SHEET		1	
	★ 90	00D 445 8004 007	WIRE CLAMPER		20	
	91	00D 144 2928 008	FRONT PANEL ASS'Y		1	*

Ref. No.	Part No.	Part Name	Remarks	Q'ty	New
	92	00D 411 2076 009	SW BRACKET	1	*
	93	00D 113 9303 130	POWER KNOB ASS'Y	1	
	94	00D 113 1994 136	P.KNOB ASS'Y(MAIN)	2	
	95	00D 412 5206 002	EARTH PLATE	1	*
	96	00D 441 1991 018	PLATE(M)	1	*
	97	00D 441 1992 004	PLATE(F)	1	*
★	98	00D 203 0667 000	1P CON. ASS'Y	1	
★	99	00D 009 9046 033	1P(F3)CORD ASS'Y	1	P-103
★	100	00D 009 9046 046	1P(F3)CORD ASS'Y	1	P-104
★	101	00D 203 4871 038	3P KR-KR RIBBON 100	1	CN038
★	102	00D 203 6385 098	4P KR-KR RIBBON 250	1	CN041
★	103	00D 203 8341 030	5P KR-KR RIBBON 100	1	CN051
★	104	00D 204 2983 015	7P EH-EH CON.CORD	1	CN073
★	105	00D 204 6361 002	14P KR-KR RIBBON 550	1	CN141
	106	00D 144 2932 007	SIDE COVER(L)	1	*
	107	00D 441 1795 010	PLATE (T/C)	4	
	108	00D 144 2933 006	SIDE COVER(R)	1	*
	109	00D 144 2930 009	TOP COVER(A)	1	*
	110	00D 441 2000 005	PLATE(TC)	4	
	111	00D 144 2931 008	TOP COVER(B)	1	*
	112	00D 112 0937 010	KNOB(M) ASS'Y	1	*
	113	00D 112 0938 006	KNOB (F) ASS'Y	1	
	114	00D 112 0787 040	KNOB(MARU) ASS'Y	2	
★	115	00D 209 0325 007	SHORT PIN	2	
★	116	00D 513 1581 008	SERIAL NO. SHEET	1	
★	118	00D 203 0748 039	1P CON. ASSY	1	P-211P-212
★	119	00D 415 0730 019	UL TUBE(8.3)BK	2	
★	120	00D 125 0075 020	CHUKOH TAPE	1	
★	121	00D 125 0092 029	BUTYL TAPE (W=15)	2	
★	122	00D 125 0097 008	BUTYL TAPE(W50 T2)	3	
★	123	00D 125 0097 011	BUTYL TAPE(W25 T2)	11	
★	124	00D 125 0096 025	NITOFロン TAPE(W15)	2	
★	125	00D 125 0096 009	NITOFロン TAPE(W50)	3	
★	126	00D 125 0096 012	NITOFロン TAPE(W25)	12	
★	127	00D 461 1012 043	RUBBER FOAM	1	
<b>SCREWS</b>					
	201	00D 470 0009 022	3X6 CPS (SW.W) ZNP	28	
	202	00D 471 3303 029	3X6 CBS-B	2	
	203	00D 471 3409 020	4X16 CBS-B	4	
	204	00D 471 3415 014	4X40 CBS	4	
	205	00D 471 3832 008	3X8 CBS-CU	4	
	206	00D 471 9058 006	SPECIAL SCREW	16	
	208	00D 473 7003 017	3X8 CFTS (S)-B	2	
	209	00D 473 7004 087	4X14 CBTS(S)-B	4	
	210	00D 473 7007 000	4X8 CBTS (S)-B	14	
	211	00D 473 7007 039	4X20 CBTS (S)-B	4	
	212	00D 473 7500 044	3X8 CBTS (P)-B	1	
	213	00D 473 7500 060	3X18 CBTS (P)	18	
	214	00D 473 7501 014	3X14 CBTS (P)-Z	2	
	215	00D 473 7508 017	3X10 CBTS (P)-B	8	
	216	00D 473 7511 017	3X12 CFTS (P)-Z	6	
	217	00D 473 8007 038	3X14 CUP SCREW	4	
	218	00D 473 8034 001	3X8 CBTS (B)-CU	66	

	Ref. No.	Part No.	Part Name	Remarks	Q'ty	New
	219	00D 473 8034 098	3X10 CBTS(B)-B		16	
	220	00D 477 0064 107	FIXING SCREW		10	
	221	00D 477 0153 018	3X16 CPTS(B) SW W		30	
	222	00D 471 1832 013	M3-SEMS SCREW(6W)		8	
	223	00M 512 6030 8M0	B.T.SCREW EX600240		7	
	★ 224	00D 473 8083 007	3X6 CBTS (B)-CU		2	

PACKING VIEW

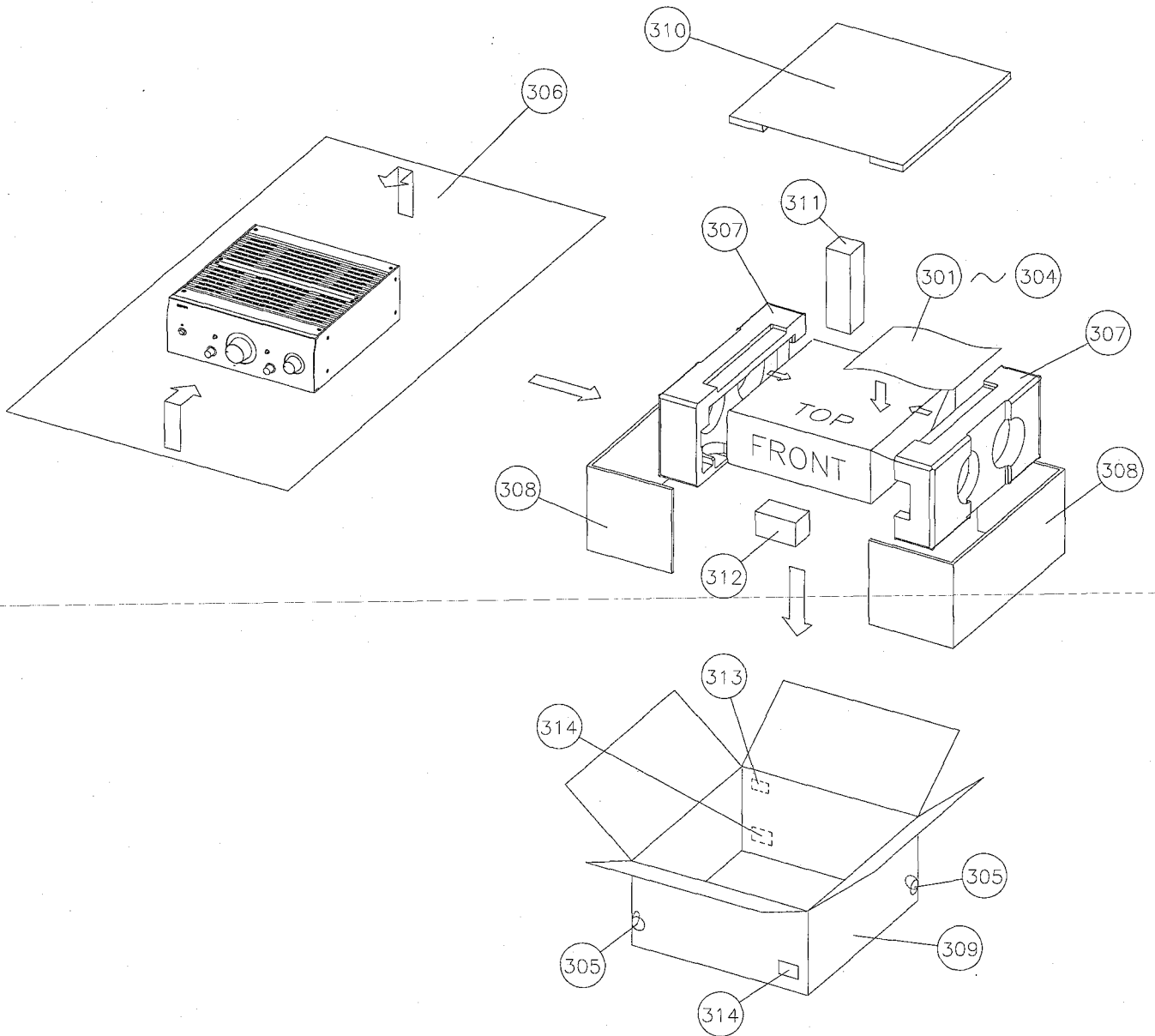

PARTS LIST OF PACKING & ACCESSORIES

\*本表に記載されている部品は、補修用部品のため製品に使用している部品とは一部、形状、寸法などが異なる場合があります。

	Ref. No.	Part No.	Part Name	Remarks	Q'ty	New
⚠	301	00D 505 8006 019	ENVELOPE		1	
	302	00D 206 2215 006	AC CORD-E1/10A/INLET		1	*
	303	00D 511 4334 007	INST. MANUAL		1	*
	304	00D 515 0921 403	S.S.LIST(EX)		1	
	305	00D 513 9111 030	COLOR LABEL		2	
	306	00D 504 0192 106	CABINET SHEET	T0.3X1300X750	1	
	307	00D 503 1250 112	CUSHION ASS'Y		1	
	308	00D 501 2294 003	SPACER		2	*
	309	00D 501 2019 097	CARTON CASE		1	*
	310	00D 502 0944 015	CUSHION ASS'Y		1	*
	311	00D 502 0898 048	PAD		1	*
	312	00D 502 0898 051	PAD		1	*
	313	-	BAR CODE LABEL		1	
	314	-	CONT.CARD(L)		1	

## NOTE FOR SCHEMATIC DIAGRAM

### WARNING:

Parts marked with this symbol  $\triangle$  have critical characteristics. Use ONLY replacement parts recommended by the manufacturer.

### CAUTION:

Before returning the unit to the customer, make sure you make either (1) a leakage current check or (2) a line to chassis resistance check. If the leakage current exceeds 0.5 milliamps, or if the resistance from chassis to either side of the power cord is less than 460 kohms, the unit is defective.

### WARNING:

DO NOT return the unit to the customer until the problem is located and corrected.

### NOTICE:

ALL RESISTANCE VALUES IN OHM. k=1,000 OHM

M=1,000,000 OHM

ALL CAPACITANCE VALUES IN MICRO FARAD.

P=MICRO-MICRO FARAD

EACH VOLTAGE AND CURRENT ARE MEASURED AT

NO SIGNAL INPUT CONDITION.

CIRCUIT AND PARTS ARE SUBJECT TO CHANGE

WITHOUT PRIOR NOTICE.

GND of signal circuit is connected to GND of control circuit through chassis.

In observing signals detaching the Input P.W.B. or the Control P.W.B. from the chassis, please connect the grounding point (Grounding side of Input pin jacks except for PHONO on Input P.W.B., W901 on Control P.W.B.) to chassis.

## 配線図について

$\triangle$ 印の部品は安全を維持するために重要な部品です。従って交換時は必ず指定の部品を使用してください。

### 注)

- (1) 指定なき抵抗値は  $\Omega$ 、k は  $k\Omega$ 、M は  $M\Omega$  を示す。
- (2) 指定なきコンデンサーの値は  $\mu F$ 、p は  $pF$  を示す。
- (3) 各部の電圧は無信号の値を示す。
- (4) この配線図は基本配線図です。改良等のため変更することがありますのでご了承ください。
- (5) 信号回路のグラウンドと制御回路のグラウンドはシャーシを介して接続されています。  
入力基板およびコントロール基板をセットより取り外して信号を観測する場合にはグラウンド部分をシャーシに接続する必要があります。(入力基板 PHONO 以外の入力ピンジャックのグラウンド側、コントロール基板 W901)

# WIRING DIAGRAM

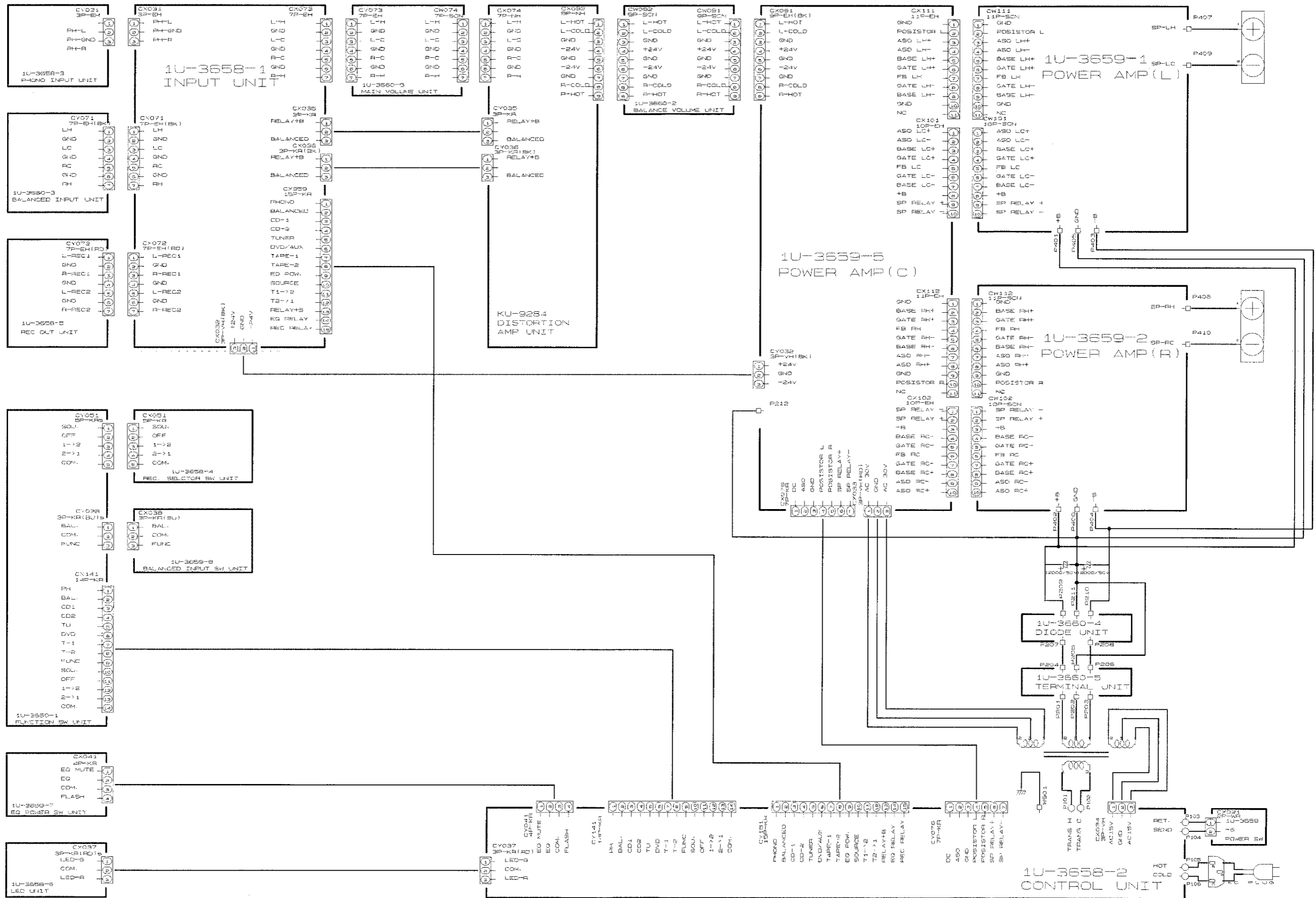



1 2 3 4 5 6 7 8 9 10 11

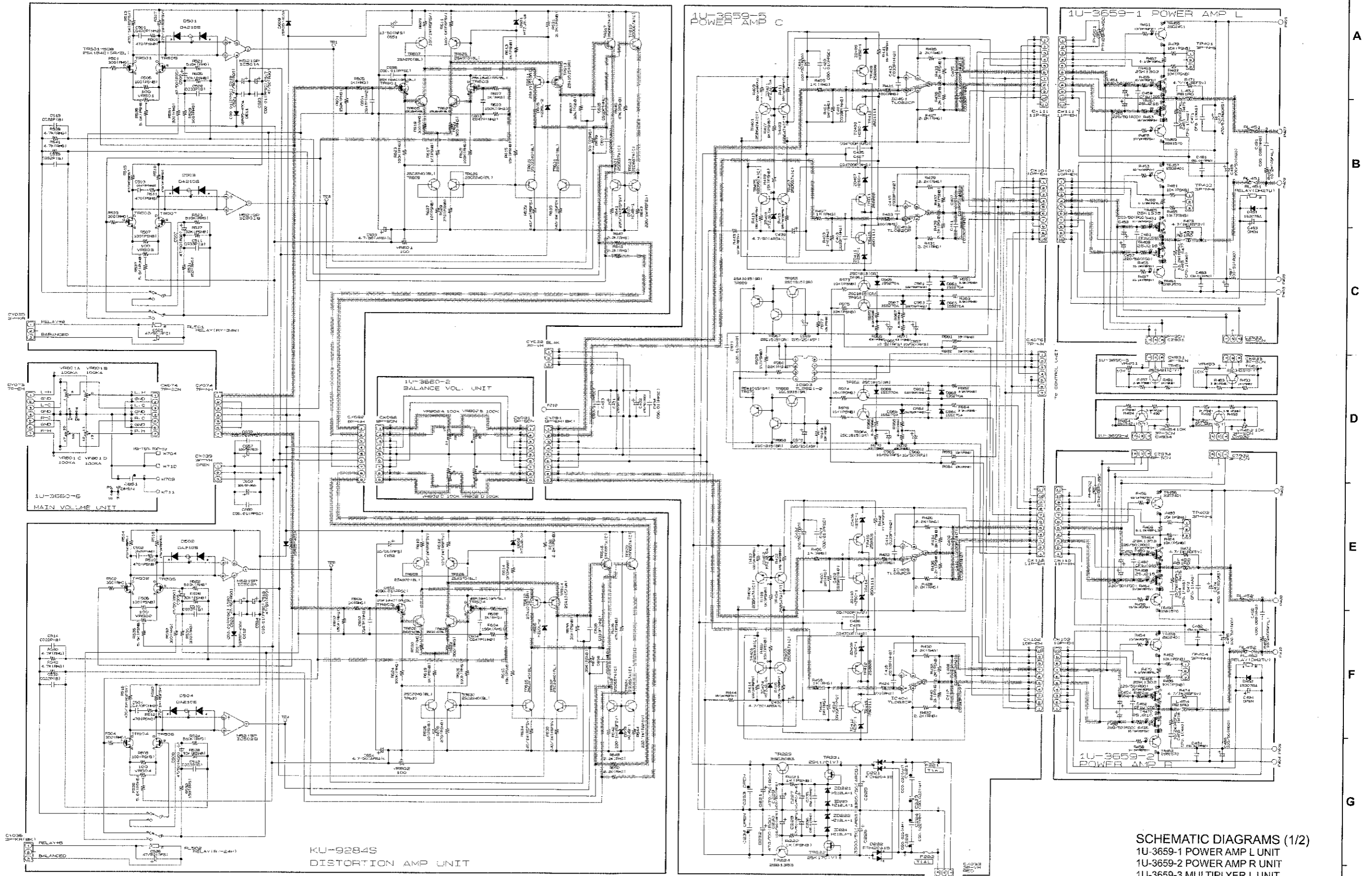

SCHEMATIC DIAGRAMS (1/2)  
 1U-3659-1 POWER AMP L UNIT  
 1U-3659-2 POWER AMP R UNIT  
 1U-3659-3 MULTIPLYER L UNIT  
 1U-3659-4 MULTIPLYER R UNIT  
 1U-3659-5 POWER AMP C UNIT  
 1U-3660-2 BALANCE VOLUME UNIT  
 1U-3660-6 MAIN VOL UNIT

SIGNAL LINE

A  
B  
C  
D  
E  
F  
G  
H

SCHEMATIC DIAGRAMS (2/2)

1 2 3 4 5 6 7 8 9 10 11

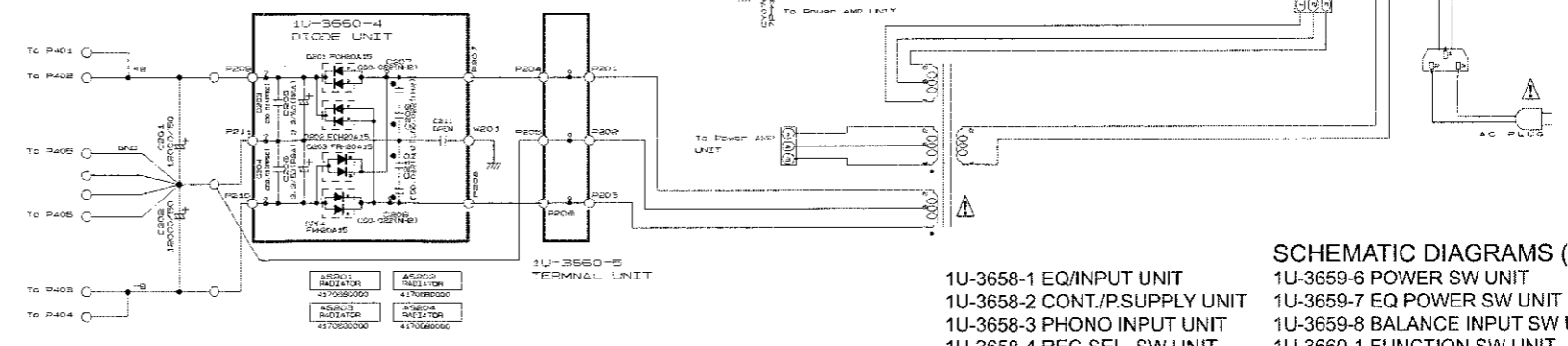
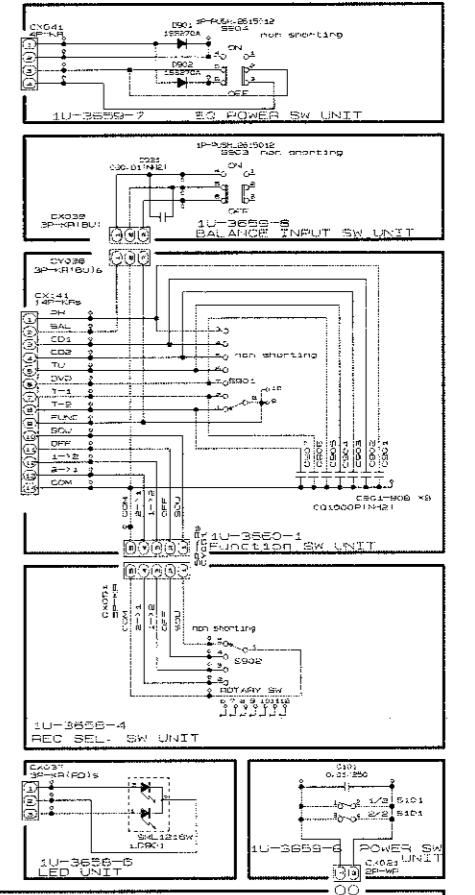
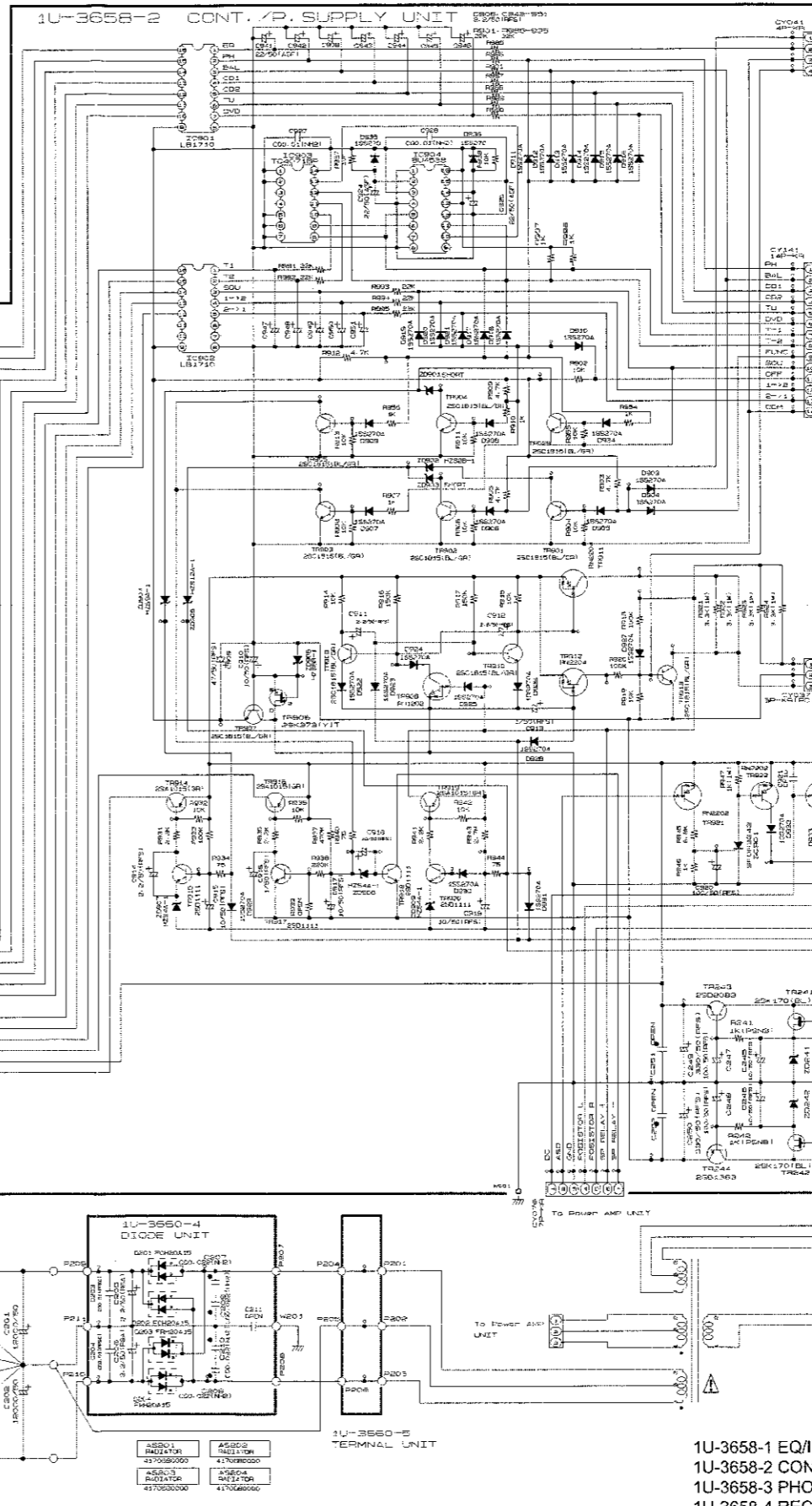
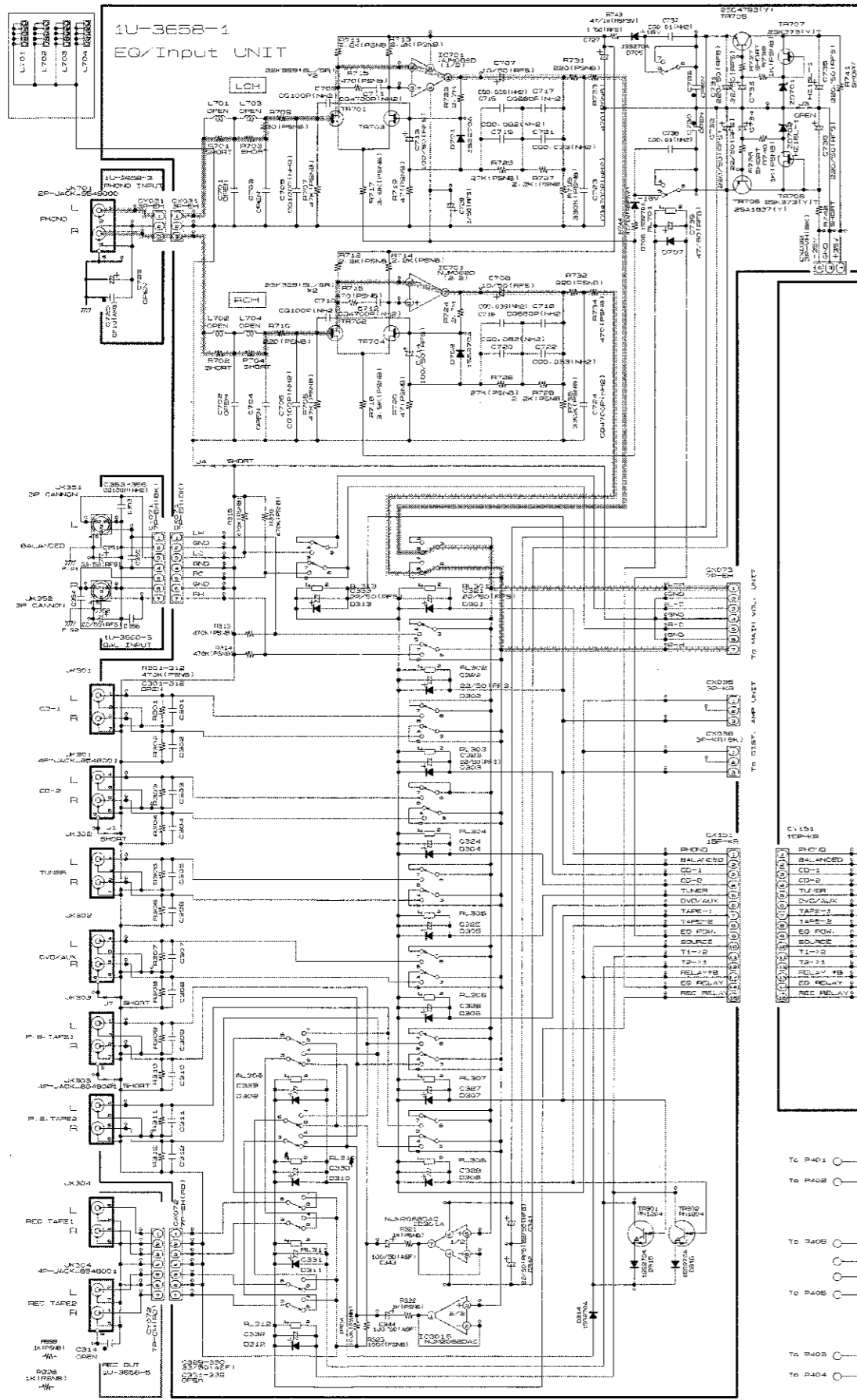

- 1U-3658-1 EQ/INPUT UNIT
- 1U-3658-2 CONT./P. SUPPLY UNIT
- 1U-3658-3 PHONO INPUT UNIT
- 1U-3658-4 REC SEL. SW UNIT
- 1U-3658-5 REC OUT UNIT
- 1U-3658-6 LED UNIT
- 1U-3659-6 POWER SW UNIT
- 1U-3659-7 EQ POWER SW UNIT
- 1U-3659-8 BALANCE INPUT SW UNIT
- 1U-3660-1 FUNCTION SW UNIT
- 1U-3660-3 BALANCED INPUT UNIT
- 1U-3660-4 DIODE UNIT
- 1U-3660-5 TERMINAL UNIT

----- SIGNAL LINE

A  
B  
C  
D  
E  
F  
G  
H

SCHEMATIC DIAGRAMS (1/2)

1 2 3 4 5 6

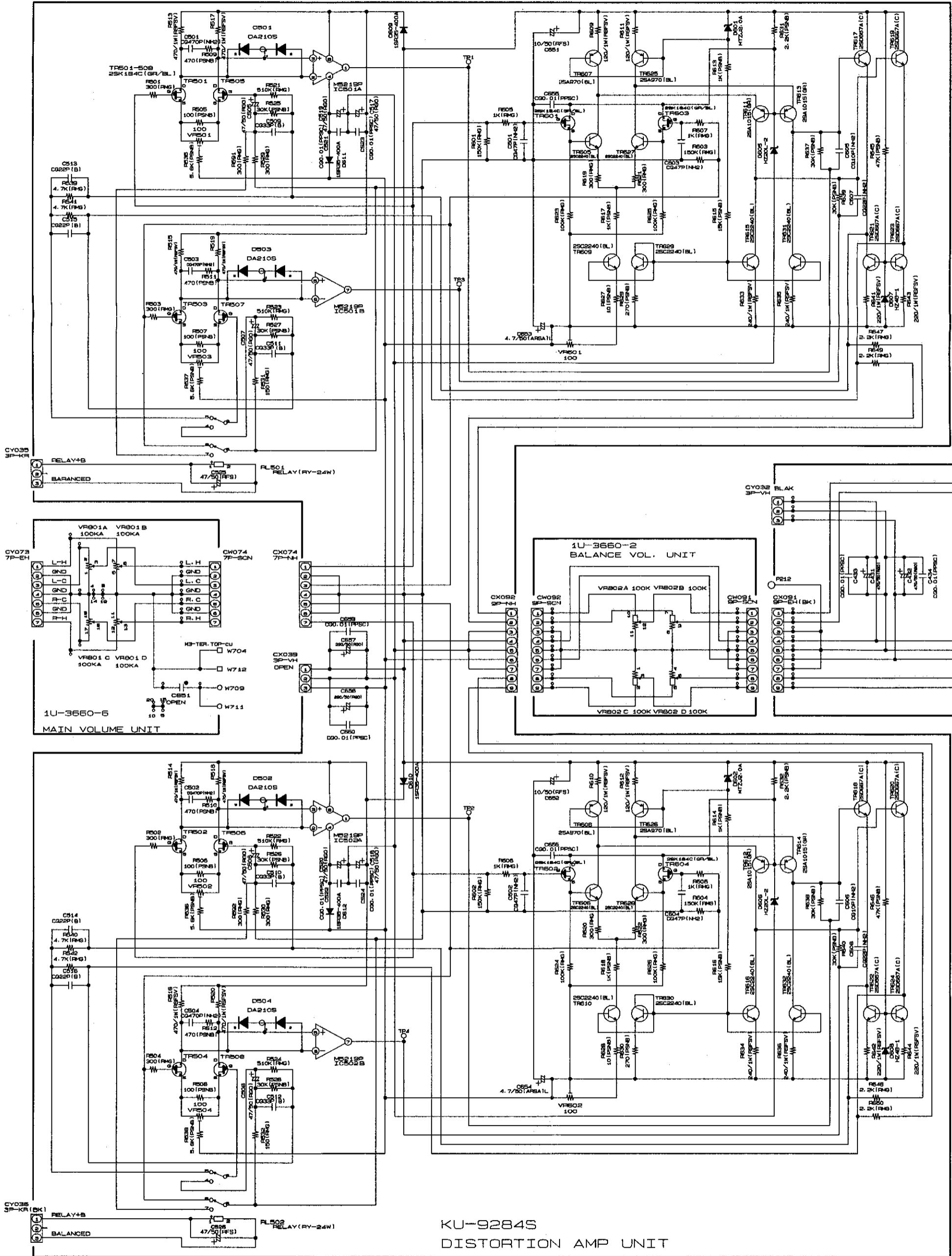

KU-92845  
DISTORTION AMP UNIT

1U-3659-1 POWER AMP L

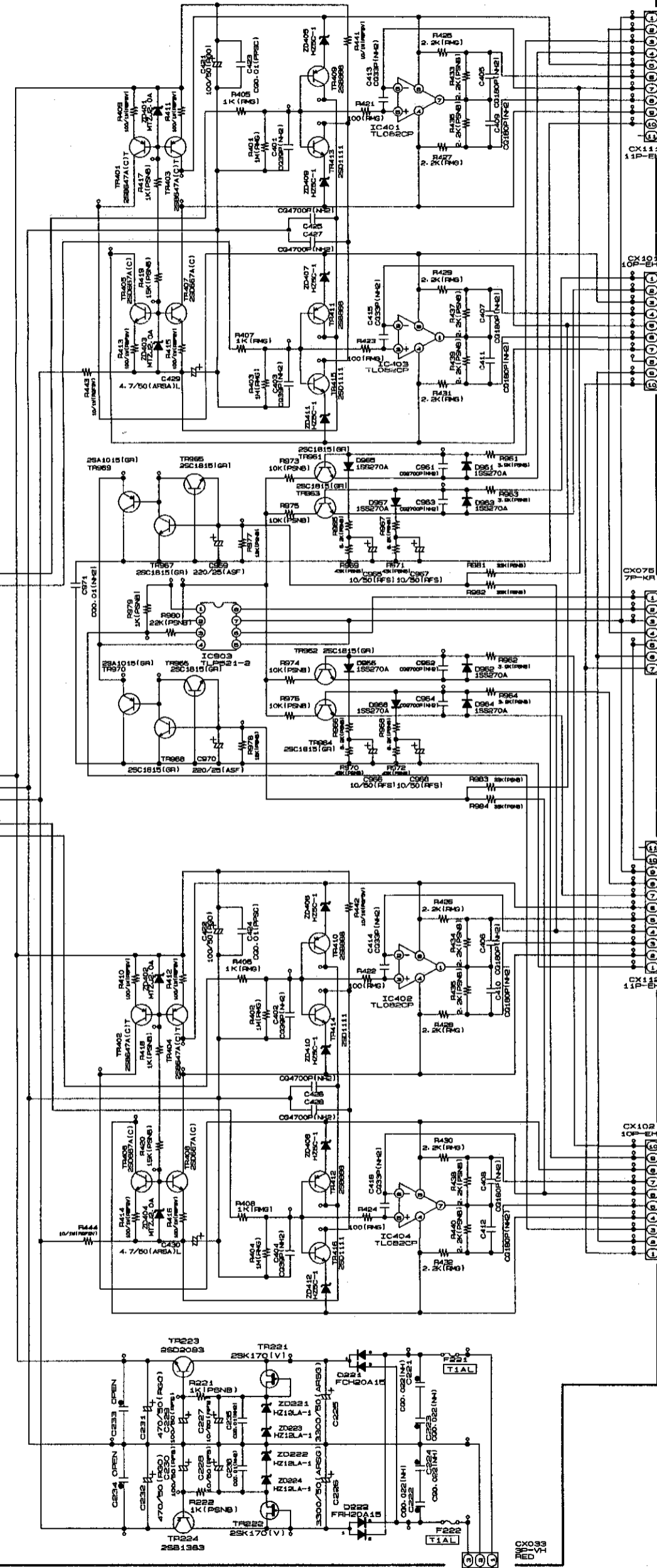

1U-3659-1 POWER AMP L

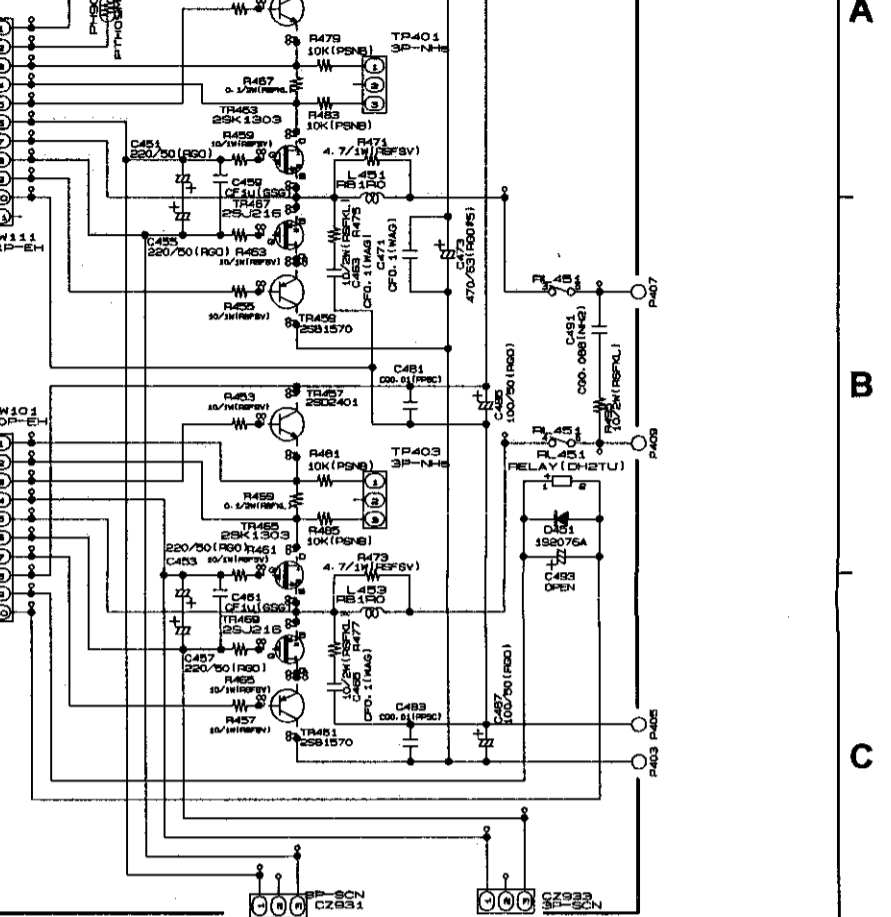

1U-3659-3 MULTIPLYER L UNIT

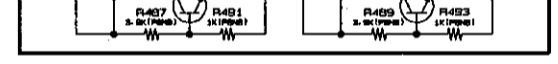

1U-3659-4 MULTIPLYER R UNIT

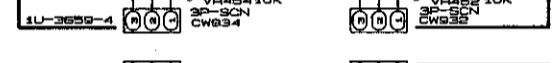

1U-3659-2 POWER AMP R

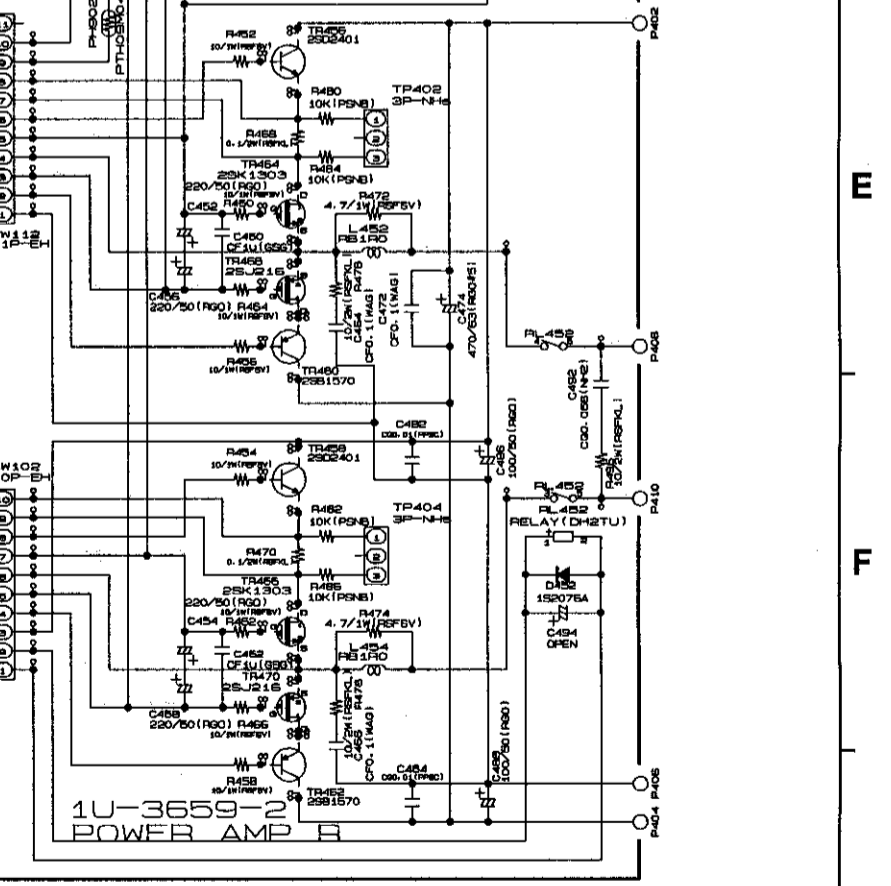

**SCHEMATIC DIAGRAMS (1/2)**  
 1U-3659-1 POWER AMP L UNIT  
 1U-3659-2 POWER AMP R UNIT  
 1U-3659-3 MULTIPLYER L UNIT  
 1U-3659-4 MULTIPLYER R UNIT  
 1U-3659-5 POWER AMP C UNIT  
 1U-3660-2 BALANCE VOLUME UNIT  
 1U-3660-6 MAIN VOL UNIT

SIGNAL LINE

A  
B  
C  
D  
E  
F  
G  
H

SCHEMATIC DIAGRAMS (2/2)

1

2

3

4

5

6

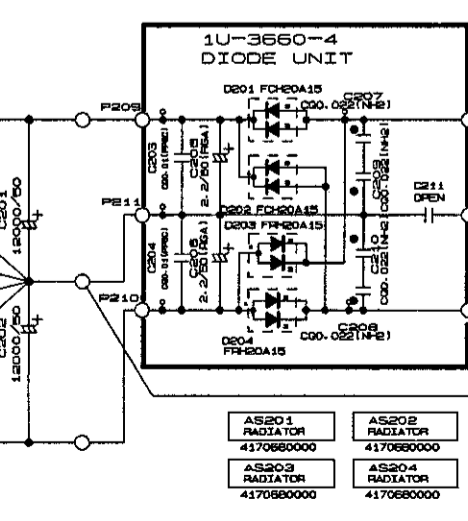
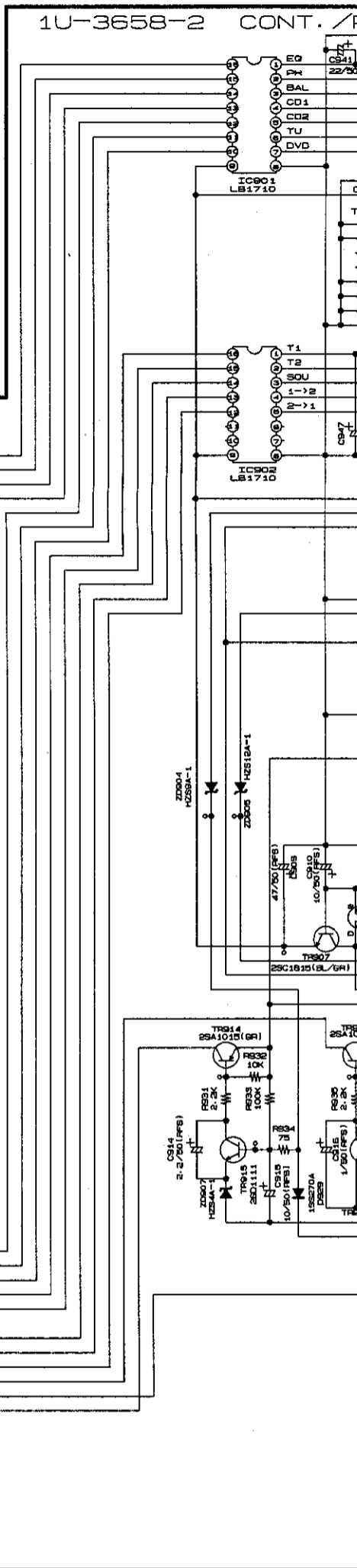
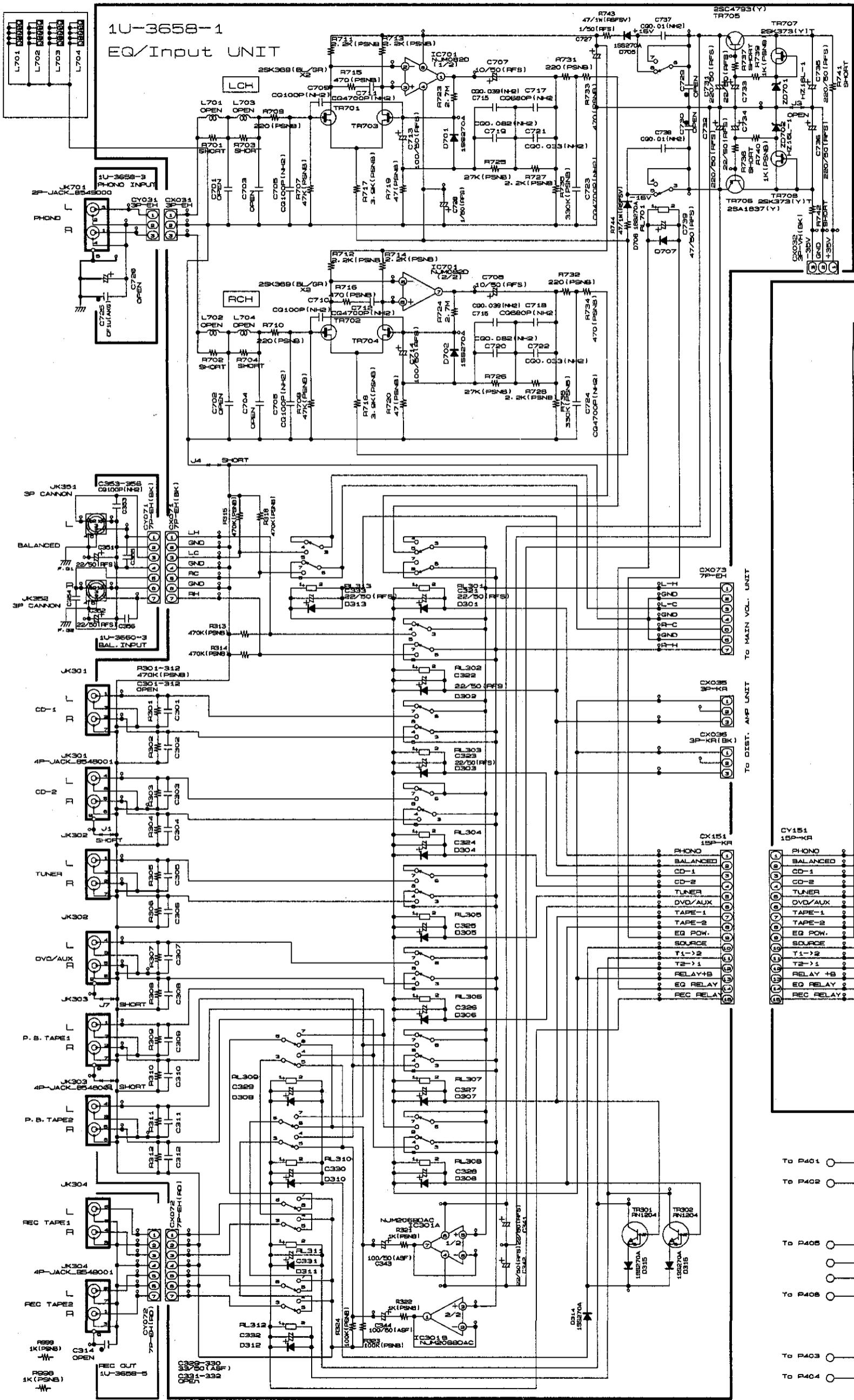

- AS201 RADIATOR 4170680000
- AS202 RADIATOR 4170680000
- AS203 RADIATOR 4170680000
- AS204 RADIATOR 4170680000

3658-2 CONT./P.SUPPLY UNIT

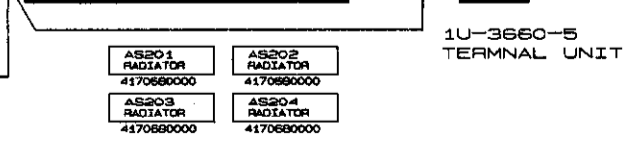
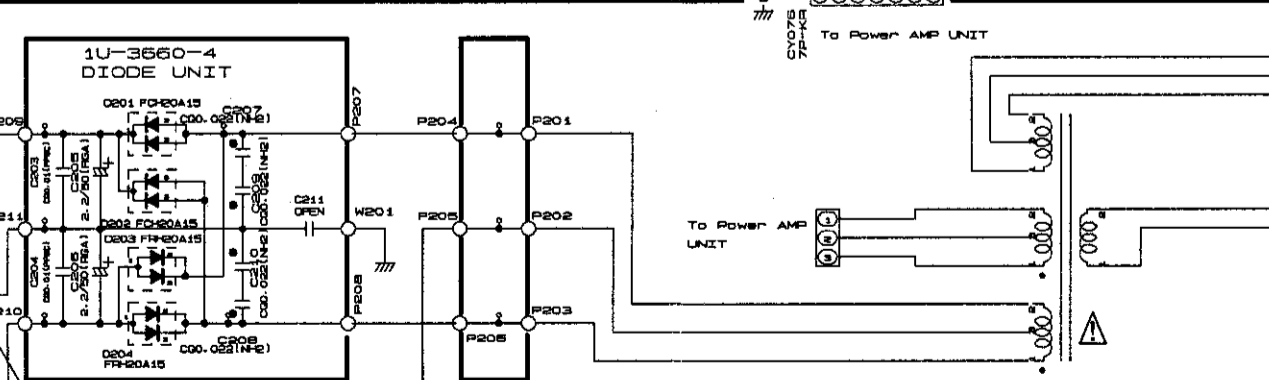
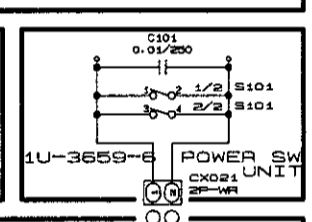
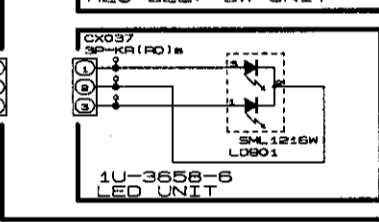
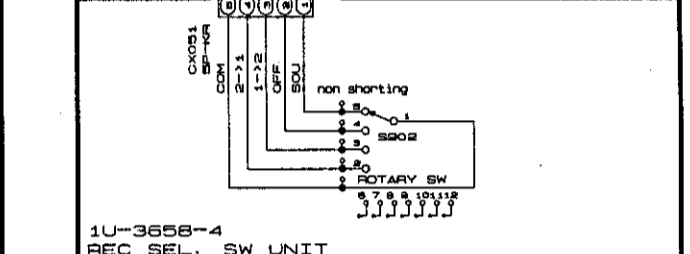
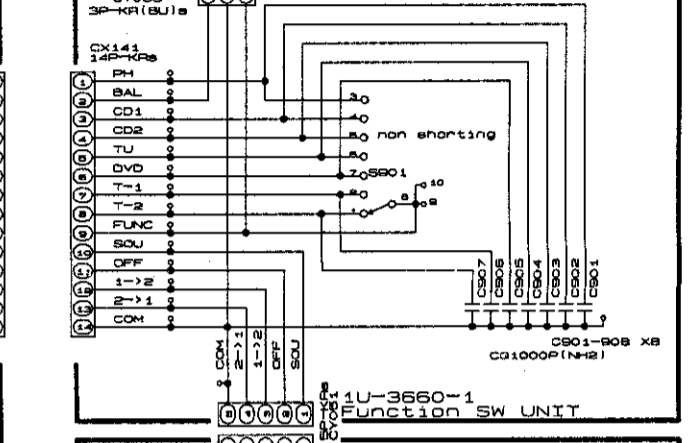
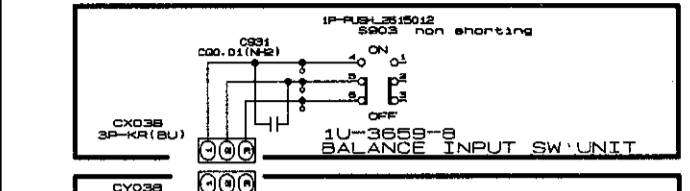
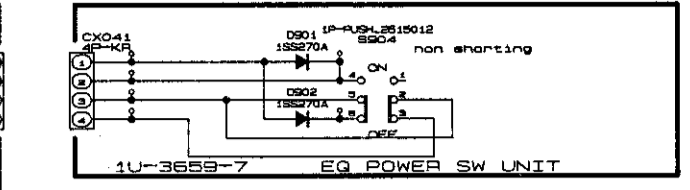
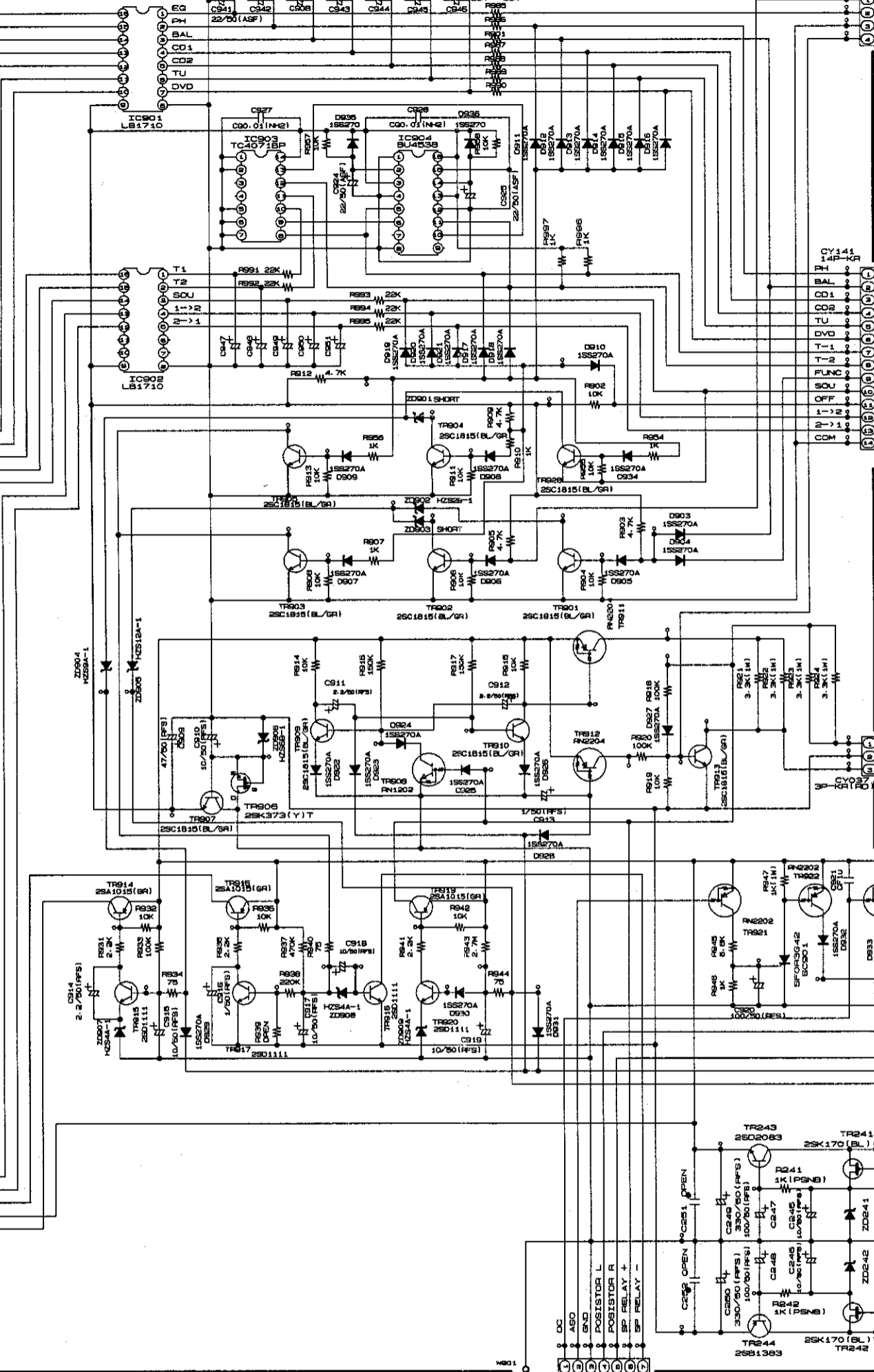

AS201 RADIATOR 4170680000	AS202 RADIATOR 4170680000
AS203 RADIATOR 4170680000	AS204 RADIATOR 4170680000

SIGNAL LINE

- 1U-3658-1 EQ/INPUT UNIT
- 1U-3658-2 CONT./P.SUPPLY UNIT
- 1U-3658-3 PHONO INPUT UNIT
- 1U-3658-4 REC SEL. SW UNIT
- 1U-3658-5 REC OUT UNIT
- 1U-3658-6 LED UNIT
- 1U-3659-6 POWER SW UNIT
- 1U-3659-7 EQ POWER SW UNIT
- 1U-3659-8 BALANCE INPUT SW UNIT
- 1U-3660-1 FUNCTION SW UNIT
- 1U-3660-3 BALANCED INPUT UNIT
- 1U-3660-4 DIODE UNIT
- 1U-3660-5 TERMINAL UNIT

A

B

C

D

E

F

G

H