

33432

DENON

Hi-Fi Pre-Main Amplifier

SERVICE MANUAL MODEL PMA-770/750

SOLID STATE
PRE MAIN AMPLIFIER

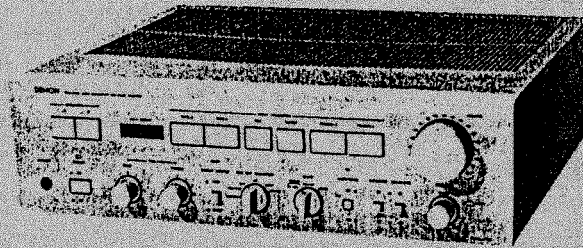

PMA-770

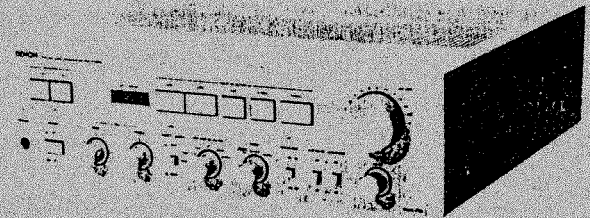

PMA-750

CONTENTS

SPECIFICATIONS	1~2
BLOCK DIAGRAM	3
METHOD OF ADJUSTMENTS	4
EXPLODED VIEW OF CABINET & CHASSIS	5
EXPLODED VIEW OF PARTS LIST	6~8
PRINTED CIRCUIT BOARD PATTERNS AND PARTS LIST	
TONE EQ. UNIT ETC-453, 453J	9~12
REC & LCD UNIT ETC-454B, 454K	13~14
INPUT & EQ. UNIT ETC-452B, 452K	15~18
WIRING DIAGRAM	20, 21
CONNECTION DIAGRAM	19, 21

NIPPON COLUMBIA CO., LTD.

SPECIFICATIONS

• PMA-770

POWER AMPLIFIER SECTION

Circuit Type:	All stage direct DC servo circuit
Rated Output Power:	Both channel drive 20 Hz to 20 kHz 100 W + 100 W (DIN, U.K., EUROPE, U.S.A.) (8 ohm Load) 1 kHz (4 ohm Load) 150 W + 150 W (DIN, U.K., U.S.A.) 1 kHz (4 ohm Load) 50 W + 50 W (IEC) (Subject to change by temperature test)
Total Harmonic Distortion:	0.008% (20 Hz – 20 kHz at –3 dB rated output 8 ohm Load) 0.02% (20 Hz – 20 kHz at rated output 8 ohm Load) (U.S.A.)
Intermodulation Distortion:	Below 7 kHz / 60 Hz : 1/4 0.002% (at amplitude output equivalent to rated output)
Output Band Width:	5 Hz – 100 kHz (IHF THD 0.035%)
Transmission Characteristics:	1 Hz – 250 kHz +0 dB 150 mV –3 dB (at 1 W output)
Input Sensitivity:	150 mV
Input Impedance:	47 k ohm
Output Impedance:	0.08 ohm (1 kHz)
Output Terminals:	Speaker: A and B Load 4 – 16 ohm A + B Load 8 – 16 ohm Headphone/Stereo headphone

EQUALIZER AMPLIFIER SECTION

Equalizer Amplifier Output:	Maximum Output: 10 V (at 47 k ohm Load) Rated Output: 150 mV Total harmonic wave distortion: below 0.002% (at 1 kHz, 8 V output)
Input Sensitivity/Input Impedance:	PHONO-1, 2 MM 2.5 mV 47 k ohm MC 125 μ V 100 ohm TUNER 150 mV 47 k ohm AUX, TAPE 150 mV 47 k ohm
RIAA Deviation:	PHONO-1, 2 MM within \pm 0.2 dB (20 Hz – 100 kHz) MC within \pm 0.2 dB (20 Hz – 100 kHz)

OVERALL CHARACTERISTICS

SN Ratio (IHFA Network):	PHONO-1, 2 MM 90 dB (input terminals short-circuited for 2.5 mV input) MC 73 dB (input terminals short-circuited for 250 μ V input)
Tone Control Adjustable Range:	TUNER, TAPE, AUX: 110 dB (input terminals short-circuited) BASS 100 Hz \pm 8 dB TREBLE 10 kHz \pm 8 dB
Filtering Characteristics:	SUBSONIC 18 Hz, 6 dB/oct
Loudness Characteristics:	Low frequency 100 Hz + 7 dB High frequency 10 kHz + 6 dB

AC OUTLET:
(For U.S.A. and Canada)

POWER SOURCE:

POWER CONSUMPTION:

DIMENSIONS:

WEIGHT:

SWITCHED x 2, 100 W (Total)
UNSWITCHED x 1, 250 W
Germany and France AC 220 V, 50 Hz; U.K. AC 240 V, 50 Hz;
U.S.A. AC 120 V, 60 Hz; Hong Kong AC 200V, 50 Hz
270 W (U.S.A.); 400 W (IEC); 290 W (Hong Kong);
800 W Maximum Output
434 mm (W) x 132 mm (H) x 407 mm (D)
(including rubber feet, control knobs, and terminals)
12 kg

Design and specifications are subject to change without prior notice.

NOTE: The following code correspond to the appropriate models.
E2 for Europe EF for France, EK for U.K., E3 for U.S.A., E3 for Canada and E1 for Hong Kong, Singapore.
This Service Manual is prepared based on PMA-770 E2.

SPECIFICATIONS

• PMA-750

POWER AMPLIFIER SECTION

Circuit Type:	All stage direct DC servo circuit
Rated Output Power:	Both channel drive 20 Hz to 20 kHz 80 W + 80 W (DIN, U.K., EUROPE, U.S.A.) (8 ohm Load) 1 kHz (4 ohm Load) 100 W + 100 W (DIN, U.K., U.S.A.) 1 kHz (4 ohm Load) 50 W + 50 W (IEC) (Subject to change by temperature test)
Total Harmonic Distortion:	0.008% (20 Hz – 20 kHz at –3 dB rated output 8 ohm Load) 0.02% (20 Hz – 20 kHz at rated output 8 ohm Load) (U.S.A.)
Intermodulation Distortion:	Below 7 kHz / 60 Hz : 1/4 0.002% (at amplitude output equivalent to rated output)
Output Band Width:	5 Hz – 100 kHz (IHF THD 0.035%)
Transmission Characteristics:	1 Hz – 250 kHz +0 dB 150 mV –3 dB (at 1 W output)
Input Sensitivity:	150 mV
Input Impedance:	47 k ohm
Output Impedance:	0.08 ohm (1 kHz)
Output Terminals:	Speaker: A and B Load 4 – 16 ohm A + B Load 8 – 16 ohm Headphone/Stereo headphone

EQUALIZER AMPLIFIER SECTION

Equalizer Amplifier Output:	Maximum Output: 10 V (at 47 k ohm Load) Rated Output: 150 mV Total harmonic wave distortion: below 0.002% (at 1 kHz, 8 V output)
Input Sensitivity/Input Impedance:	PHONO MM 2.5 mV 47 k ohm MC 125 μ V 100 ohm TUNER 150 mV 47 k ohm AUX, TAPE 150 mV 47 k ohm
RIAA Deviation:	PHONO MM within \pm 0.2 dB (20 Hz – 100 kHz) MC within \pm 0.2 dB (20 Hz – 100 kHz)

OVERALL CHARACTERISTICS

SN Ratio (IHFA Network):	PHONO MM 88 dB (input terminals short-circuited for 2.5 mV input) MC 72 dB (input terminals short-circuited for 250 μ V input)
Tone Control Adjustable Range:	TUNER, TAPE, AUX: 110 dB (input terminals short-circuited) BASS 100 Hz \pm 8 dB TREBLE 10 kHz \pm 8 dB
Filtering Characteristics:	SUBSONIC 18 Hz, 6 dB/oct
Loudness Characteristics:	Low frequency 100 Hz + 7 dB High frequency 10 kHz + 6 dB

AC OUTLET:
(For U.S.A. and Canada)

POWER SOURCE:

POWER CONSUMPTION:

DIMENSIONS:

WEIGHT:

SWITCHED x 2, 100 W (Total)
UNSWITCHED x 1, 250 W
Germany and France AC 220 V, 50 Hz; U.K. AC 240 V, 50 Hz;
U.S.A. AC 120 V, 60 Hz; Hong Kong AC 200V, 50 Hz
230 W (U.S.A.); 400 W (IEC); 200 W (Hong Kong);
680 W Maximum Output
434 mm (W) x 132 mm (H) x 407 mm (D)
(including rubber feet, control knobs, and terminals)
12 kg

Design and specifications are subject to change without prior notice.

BLOCK DIAGRAM

• PMA-770

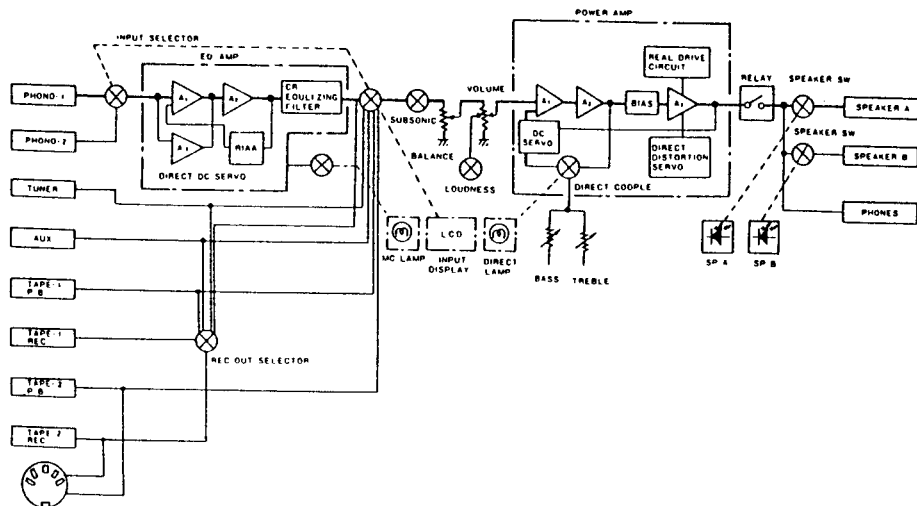

• PMA-750

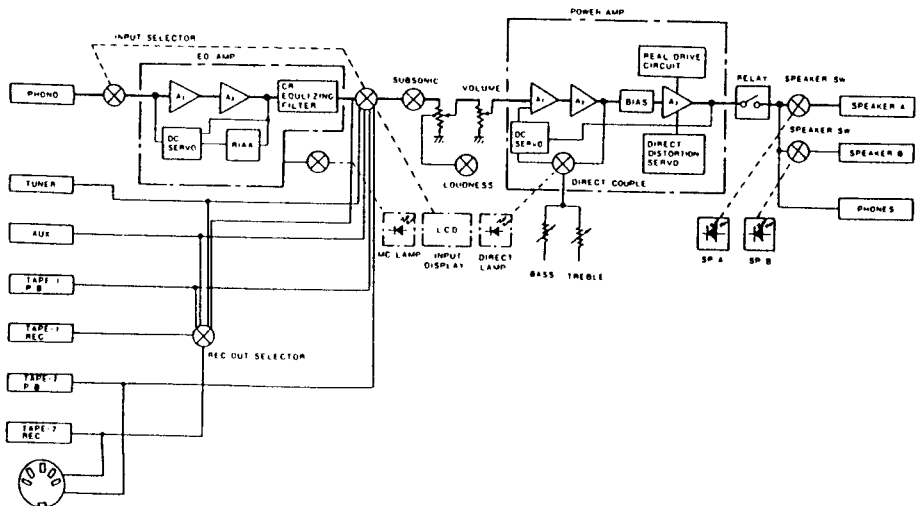

METHOD OF ADJUSTMENT

Schematic View of Tone Power for ETC-453 (PMA-770), ETC-453J (PMA-750)

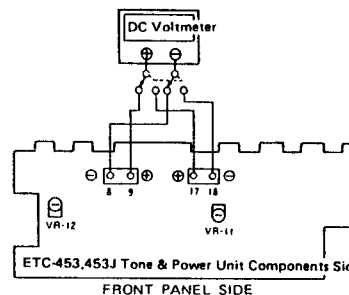

Schematic View for Input and Equalizer for ETC-452 (PMA-770), ETC-452J (PMA-750)

PMA-770

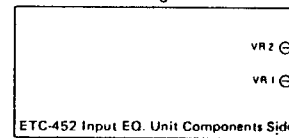
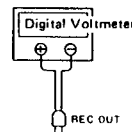

PMA-750

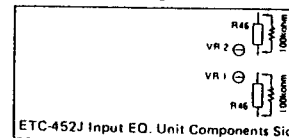
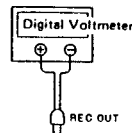

Adjustment of Idling Current (ETC-453, ETC-453J)

Preparation

1. Keep the unit away from direct wind blown by an air-conditioner and an electric fan. Keep the unit under normal conditions. Adjust the range of ambient temperature to 15 - 30°C.
2. Set the following switches as follows:
 - POWER (power switch) to off
 - VOLUME (volume control) to $-\infty$ (∞ min.)
 - DIRECT COUPLE (direct switch) to DIRECT
 - SPEAKER (speaker terminal) to no load (a speaker and a dummy resistor are not connected)

Adjustment

1. Remove the top cover and turn the variable resistors VR11 and VR12 of ETC-453 and ETC-453J (tone and power unit) in the clockwise direction until they stop. Connect a DC voltmeter between the negative terminal 9 and the positive terminal 8, and between the positive terminal 17 and the negative terminal 18.
2. Connect the power source cord to an AC outlet. Turn on the power switch. Turn the variable resistors UR11 and UR12 in the counterclockwise direction within one minute. Preset adjust the voltages at the respective test points as follows:
 - PMA-770 15 ± 2 mV
 - PMA-750 11 ± 2 mV
3. Set the variable resistors VR11 and VR12 2 to 3 minutes after the presetting as follows:
 - PMA-770 19 ± 1 mV
 - PMA-750 13 ± 1 mV

Adjustment of ETC-452 and ETC-452J

Preparation

1. Insert the short pin into the "phono" input terminal.
2. Connect a digital voltmeter between the "REC" output terminals (LCH and RCH). The output voltage at the digital voltmeter must be 0.01 - 1 mV (DC).
3. Connect a resistor of 100 k ohms (1/4 W) between the resistors R45 and R46 of 10 M ohms of the unit in order to make measurement easy (only for PMA-750).
4. Set the RECOUT SELECTOR to the "phono" position and set the volume control to $-\infty$ (∞ min.).

Adjustment

1. Turn on the power switch. After two minutes, perform the following procedures.
 - PMA-770, PMA-750
 - Adjust the variable resistor 1 (semi-fixed resistor of 100 k ohms) so that the output for LCH at the digital voltmeter reads less than 0.5 V (DC).
 - Adjust the variable resistor 2 (semi-fixed resistor of 100 k ohms) so that the output for RCH at the digital voltmeter reads less than 0.5 V (DC).

EXPLODED VIEW OF CHASSIS AND CABINET

⚠ Means important safety item, which must be replaced, when necessary, by a part specified or meeting the specification by the manufacturer.

This EXPLODED VIEW is prepared based on PMA-770E2.

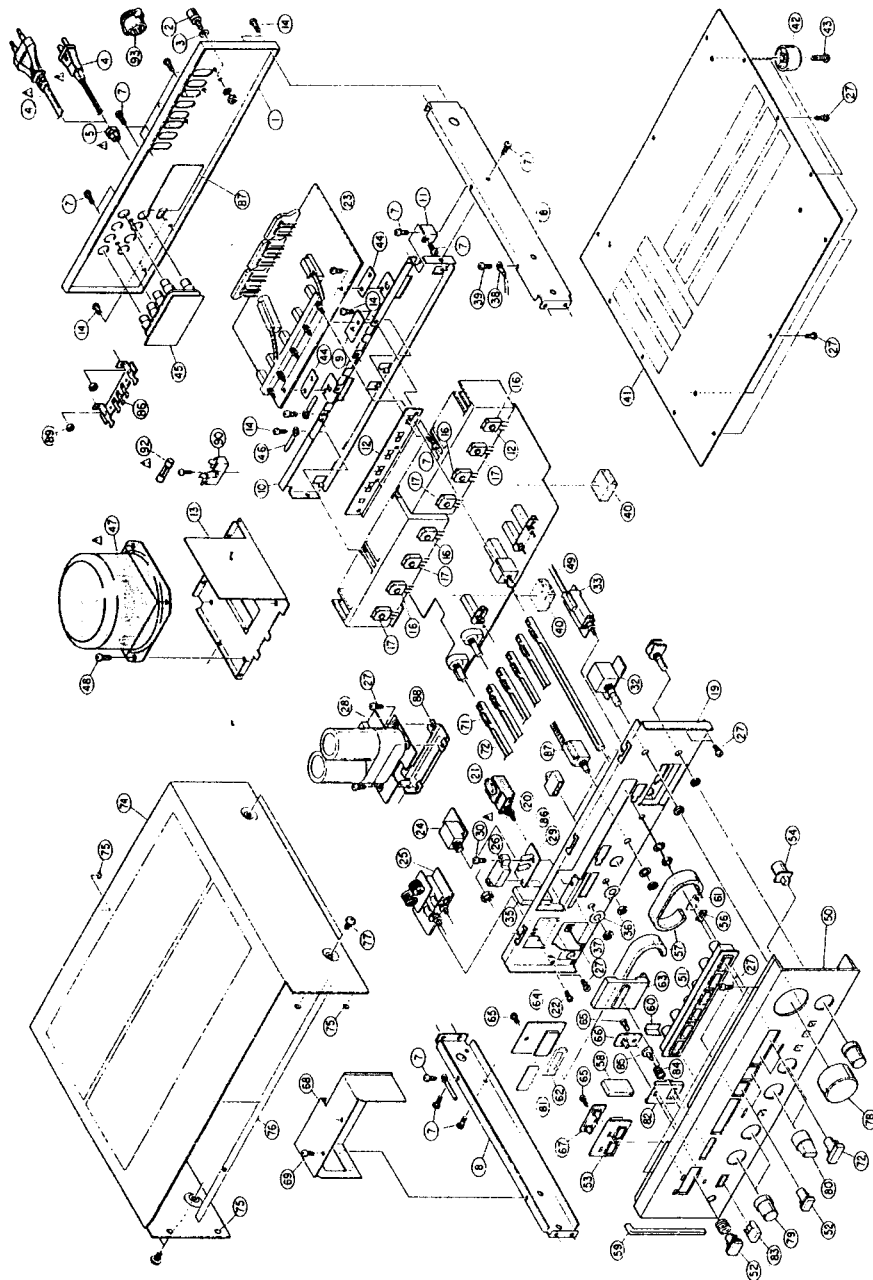

EXPLODED VIEW OF PARTS LIST

• (PMA-770)

Note: 1. See addendum list below for the parts with asterisk (*) on the Ref. No. and the other parts not included in this list.
2. The list is prepared based on E2.
3. • Mark same as PMA-750E2.

Ref. No.	Part No.	Part Name & Descriptions	Ref. No.	Part No.	Part Name & Descriptions
1	1050460000	BACK PANEL	52	1130291102	PUSH KNOB (SP)
2	2050071016	TERMINAL ASS'Y	53	1460432107	PANEL BUSH (SP)
3	4770018001	WASHER	54	1130306000	PUSH KNOB (LOUDNESS) ASS'Y
4	2062002031	AC CORD	55	-	-
5	4450020005	CORD BUSH	56	1430224002	LENS
6	4730354035	TAPPING SCREW (2)3x8 MFN1B	57	4610155011	BLIND
7	4120733224	SIDE CHASSIS	58	4610155024	BLIND
8	4410355008	HOLD PLATE	59	4610155040	BLIND
9	4110320113	MAIN CHASSIS	60	1250015006	BLIND SHEET (B)
10	4120965018	SUPPORT BRACKET	61	1430240002	FILTER
11	4410353000	SHEET	62	1430230009	WINDOW PLATE
12	4110333003	TRANS CHASSIS ASS'Y	63	1430228008	WINDOW
13	4770064107	FIXING SCREW	64	ETC-045483	LCD UNIT
14	4170153100	POWER RADIATOR	65	4770096007	PUSH RIVET
15	2718150028	TRANSISTOR 2SA1146(R)/(O)	66	ETC-045485	POWER LED UNIT
16	2730298023	TRANSISTOR 2SC2706(R)/(O)	67	ETC-045484	SPEAKER LED UNIT
17	4700012022	CROSS PAN SCREW WITH W.S.W 3x12	68	4120988008	LAMP COVER
18	4110321206	FRONT CHASSIS	69	4470052009	FIX. SCREW
19	2124263022	PUSH SWITCH	70	4120962008	CONNECTING BRACKET
20	2538003014	CERAMIC CAP 0.0047μF/50V	71	4630274066	SPRING
21	4700090006	CROSS PAN SCREW WITH S. WASHER 3x6	72	1130290103	PUSH KNOB (INPUT)
22	ETC-045281	INPUT & EQ. UNIT	73	1130291102	PUSH KNOB (SP)
23	ETC-045282	HEADPHONE JACK UNIT	74	1020128000	TOP COVER
24	ETC-045283	SPEAKER SWITCH UNIT	75	1040034006	STOPPER
25	1430229007	L.C.D. LENS	76	1220069008	SPACER
26	4730354019	TAPPING SCREW (2)3x8	77	4734801005	TAPPING SCREW (TRUS) 4x8
27	ETC-045481	RECT & LCD UNIT	78	1120265203	KNOB
28	ETC-045482	LAMP UNIT	79	1120359106	KNOB (A)
29	4730358015	TAPPING SCREW (2)3x14	80	1120360001	KNOB (B)
30	ETC-04531	tone & POWER UNIT	81	1430354019	COLOR PLATE
31	ETC-04532	VOLUME UNIT	82	1460430109	PANEL BUSH (POWER)
32	ETC-04533	CARTRIDGE SW UNIT	83	1130171222	PUSH KNOB ASS'Y
33	2120197008	ROTARY REMOTE	84	4630220007	SPRING
34	4610155037	BLIND	85	1190041002	STOPPER
35	1250014007	BLIND SHEET (A)	86	2050089008	7P W TERMINAL
36	4150209004	INSULATING SHEET	87	4150088004	INSULATING SHEET
37	2030176106	WIRE ASS'Y	88	4700042005	CROSS PAN SCREW WITH S. WASHER 3x8 (BLACK)
38	4700044005	TAPPING SCREW WITH W. 3x8	89	4756008008	NUT #3
39	4610157080	CUSHION	90	2020013004	FUSE HOLDER
40	1050450007	BOTTOM COVER	91	5130158195	FUSE LABEL
41	1048001002	FOOT	92	2061015087	FUSE (4A)
42	4730355018	TAPPING SCREW (2)3x10	93	2038084009	5P CONNECTOR (DIN)
43	4150197005	INSULATING SHEET	94	2412156003	CARBON FILM RESISTOR 470 k ohm
44	ETC-045284	SPEAKER TERMINAL UNIT	95	4630274024	PACKING & ACCESSORIES (not included EXPLODED VIEW)
45	EP-6214	CORD HOLDER	a	5040064001	CABINET SHEET
46	2335241202	POWER TRANS.	b	5030301101	CUSHION
47	4730454032	TAPPING SCREW (2)4x8 (BLACK)	c	5010755049	CARTON CASE
48	4350052018	FLEXIBLE SLIDER	d	5110994001	INST. MANUAL
49	1440912003	FRONT PANEL			
50	1460433106	PANEL BUSH (INPUT)			
51					

ADDENDUM LIST

Ref. No.	Part Name & Descriptions	E1 for Hong Kong	EK for U.K.	Part No.	E3 for U.S.A.
1	BACK PANEL	1050462008			
4	AC CORD	206031020			
5	CORD BUSH	MD-3802			
6	AC OUTLETS	2033909006			
20	PUSH SWITCH	2124263022			
21	CAPACITOR	2538003014			
23	INPUT & EQ. UNIT	ETC-0452D1			
24	HEADPHONE JACK UNIT	ETC-0452D2			
25	SPEAKER SWITCH UNIT	ETC-0452D3			
45	SPEAKER TERMINAL UNIT	ETC-0452D4			
47	POWER TRANS.	2335304107			
96	VOLTAGE SEL. SWITCH	2120186006			
97	CROSS PAN SCREW 3x6 (BLACK)	4711303034			
PACKING & ACCESSORIES (not included EXPLODED VIEW)					
c	CARTON CASE	5010755049			

EXPLODED VIEW OF PARTS LIST

(PMA-750)

- Note: 1. See addendum list below for the parts with asterisk (*) on the Ref. No. and the other parts not included in this list.
 2. The list is prepared based on E2.
 3. * Mark same as PMA-770E2.

Ref. No.	Part No.	Part Name & Descriptions	Ref. No.	Part No.	Part Name & Descriptions
1	1050459008	BACK PANEL	52	1130291102	PUSH KNOB (SP)
2	2050071016	TERMINAL ASS'Y	53	1460432107	PANEL BUSH (SP)
3	4770018001	WASHER	54	1130306000	PUSH KNOB (LOUDNESS) ASS'Y
4	2062002031	AC CORD	55	—	—
5	4450020005	CORD BUSH	56	—	—
6	—	—	57	4610155011	BLIND
7	4730354035	TAPPING SCREW (213x8 MFN1B)	58	4610155024	BLIND
8	4120732208	SIDE CHASSIS	59	4610155040	BLIND
9	4410355008	HOLD PLATE	60	—	—
10	4110320100	MAIN CHASSIS	61	—	—
11	4120965005	SUPPORT BRACKET	62	1430230009	WINDOW PLATE
12	4410353000	SHEET	63	1430228008	WINDOW
13	4110334002	TRANS CHASSIS ASS'Y	64	ETC-0454K3	LCD UNIT
14	4770064107	FIXING SCREW	65	4770006007	PUSH RIVET
15	4170156000	POWER RADIATOR	66	ETC-0454K5	POWER LED UNIT
16	2710143022	TRANSISTOR 2SA1187(O)/(Y)	67	ETC-0454K4	SPEAKER LED UNIT
17	2730243025	TRANSISTOR 2SC2838(O)/(Y)	68	ETC-0454K6	LED UNIT
18	4700012022	CROSS PAN SCREW WITH W.S.W. 3x12	69	ETC-0454K7	LED UNIT
19	4110321206	FRONT CHASSIS	70	4120962008	CONNECTING BRACKET
20	2124263022	PUSH SWITCH	71	4630274066	SPRING
21	2538003014	CERAMIC CAP. 0.0047uF 450W	72	1130290103	PUSH KNOB (INPUT)
22	4700009006	CROSS PAN SCREW WITH S. WASHER 3x6	73	1130291102	PUSH KNOB (SP)
23	ETC-0452K1	INPUT & EQ. UNIT	74	1020128000	TOP COVER
24	ETC-0452K2	HEADPHONE JACK UNIT	75	1040034006	STOPPER
25	ETC-0452K3	SPEAKER SWITCH UNIT	76	1220069008	SPACER
26	1430229010	L.C.D. LENS	77	4734801005	TAPPING SCREW (TRUS) 4x8
27	4730354019	TAPPING SCREW (213x8 RECT & LCD UNIT	78	1120265203	KNOB
28	ETC-0454K1	LAMP UNIT	79	1120359106	KNOB (A)
29	ETC-0454K2	TAPPING SCREW (213x14 TONE & POWER UNIT	80	1120374000	KNOB (C)
30	ETC-0453J1	VOLUME UNIT	81	1430354019	COLOR PLATE
31	ETC-0453J2	CARTRIDGE SW UNIT	82	1460430109	PANEL BUSH (POWER)
32	ETC-0453J3	ROTARY REMOTE	83	1130171222	PUSH KNOB ASS'Y
33	2120197008	—	84	4630220007	SPRING
34	—	—	85	1190014002	STOPPER
35	—	—	86	2050089008	7P W TERMINAL
36	1250014007	BLIND SHEET (A)	87	4150088004	INSULATING SHEET
37	4150208004	INSULATING SHEET	88	4700042005	CROSS PAN SCREW WITH S. WASHER 3x8 (BLACK)
38	2030176106	WIRE ASS'Y	89	4756008008	NUT #3
39	4700044005	TAPPING SCREW WITH W 3x8	90	2020013004	FUSE HOLDER
40	4610157080	CUSHION	91	5130159185	FUSE LABEL
41	1050450007	BOTTOM COVER	92	2061015087	FUSE (4A)
42	1048001002	FOOT	93	2038084009	5P CONNECTOR (DIN)
43	4730355018	TAPPING SCREW (213x10	94	2412156003	CARBON FILM RESISTOR 470 k ohm
44	4150197005	INSULATING SHEET			SPRING
45	ETC-0452K4	SPEAKER TERMINAL UNIT			
46	EP 6214	CORD HOLDER			
47	2335344002	POWER TRANS			
48	4730454032	TAPPING SCREW (214x18 (BLACK)			
49	4350052018	FLEXIBLE SLIDER			
50	1440928000	FRONT PANEL			
51	1460455003	PANEL BUSH (INPUT)			

ADDENDUM LIST

Ref. No.	Part Name & Descriptions	Part No.		
		E1 for Hong Kong	EK for U.K.	E3 for U.S.A.
1	BACK PANEL	1050459008	1050461009	
4	AC CORD	2062002000	2006031026	
5	CORD BUSH	MD-2982H	MD-3802	
6	AC OUTLET		2033809008	
20	PUSH SWITCH	2124263022	2124263022	
21	CAPACITOR	2538003014	2538003014	
23	INPUT & EQ. UNIT	ETC-0452K1	ETC-0452M1	
24	HEADPHONE JACK UNIT	ETC-0452K2	ETC-0452M2	
25	SPEAKER SWITCH UNIT	ETC-0452K3	ETC-0452M3	
28	RECT & LCD UNIT	ETC-0454K1	ETC-0454M1	
29	LAMP UNIT	ETC-0454K2	ETC-0454M2	
45	SPEAKER TERMINAL UNIT	ETC-0452K4	ETC-0452M4	
47	POWER TRANS	2335345001	2335343003	
48	TAPPING SCREW	4700031016	4730454032	
64	LCD UNIT	ETC-0454K3	ETC-0454M3	
66	POWER LED UNIT	ETC-0454K5	ETC-0454M5	
67	SPEAKER LED UNIT	ETC-0454K4	ETC-0454M4	
68	LED UNIT	ETC-0454K6	ETC-0454M6	
69	LED UNIT	ETC-0454K7	ETC-0454M7	
86	VOLTAGE SEL. SWITCH		2120186006	
97	CROSS PAN SCREW 3x6 (BLACK)		4711303034	
98	WATTAGE LABEL	5130683004	—	
99	VOLTAGE LABEL	5130362008	—	
100	BLIND SHEET	5130348006	—	
101	WIRE ASS'Y	2030176151	—	
102	EARTH LABEL	5130140000	—	
103	TOOTH WASHER #3	4753001051	—	
104	CAUTION CARD	5130364006	—	
105	TOOTH WASHER #4	4753100004	—	
PACKING & ACCESSORIES (not included EXPLODED VIEW)				
c	CARTON CASE	5010755036	5010755036	
e	IMPORTANT LABEL	5130372001	—	
f	GUARANTEE CARD	5150230000	—	

PRINTED WIRING BOARD PATTERNS AND PARTS LIST

• For PMA-770

ETC-453 TONE & EQ. UNIT

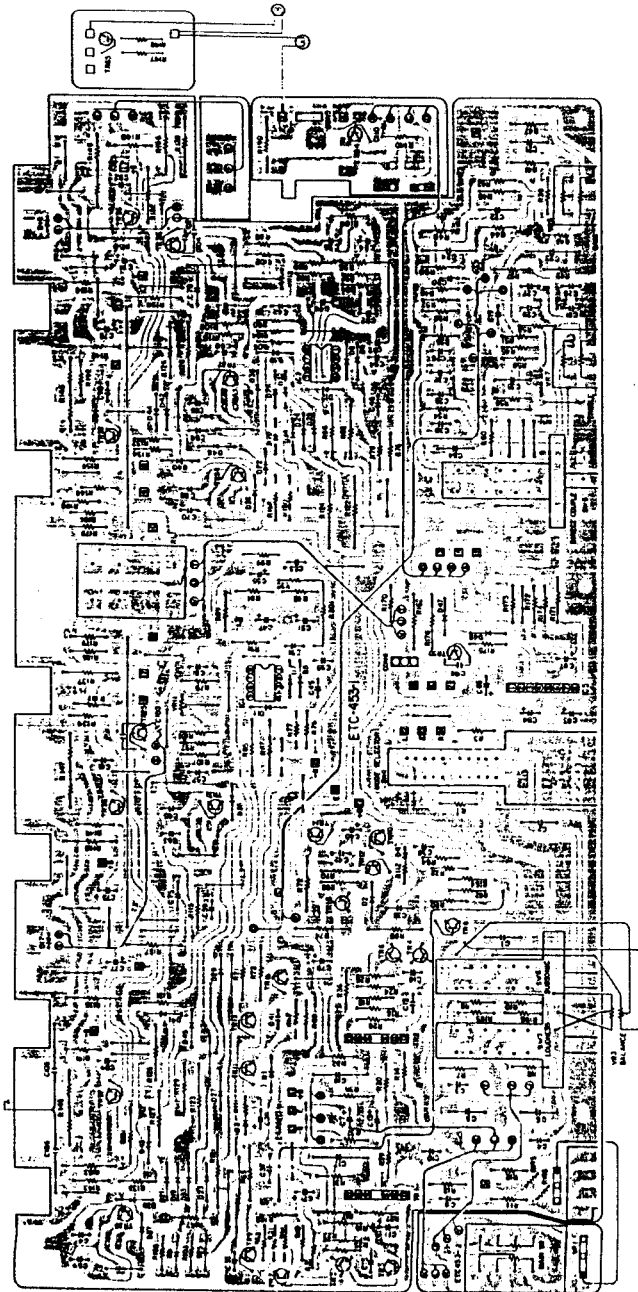

• For PMA-750

ETC-453J TONE & EQ. UNIT

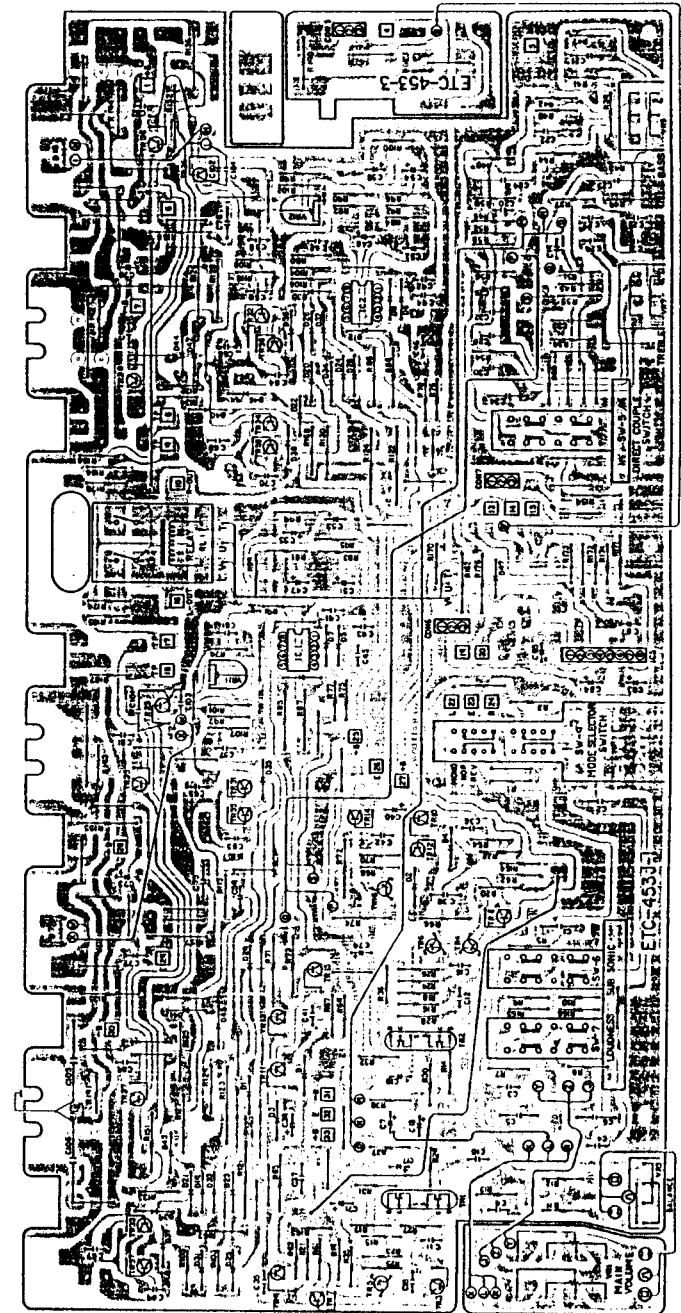

• For PMA-770

ETC-454B RECT & LCD UNIT

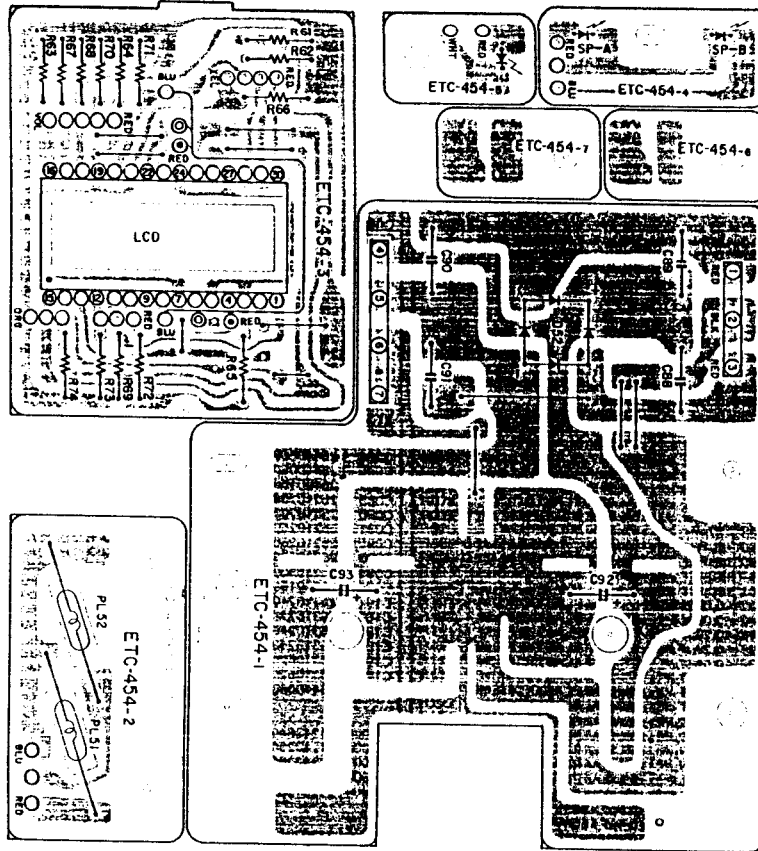

ETC-454B RECT & LCD UNIT PARTS LIST

Ref. No.	Part No.	Part Name & Descriptions	Ref. No.	Part No.	Part Name & Descriptions
SEMICONDUCTORS			OTHER PARTS		
D052	2760233005	M4C-51 DIODE		2220765000	P.W. BOARD
D053	3939149000	BG5531K GREEN LIGHT EMITTING DIODE		2050087039	3P TERMINAL
D054	3939149000	BF5531K GREEN LIGHT EMITTING DIODE		2050087042	4P TERMINAL
	3939149013	PR5531K RED LIGHT EMITTING DIODE		2090008162	JUMPER P=20mm USED 1
	3939130006	LCD DISPLAY		2090008120	JUMPER P=10mm USED 8
RESISTORS (not included Carbon Film ±5% ¼W Type)				2090008146	JUMPER P=5mm USED 2
CAPACITORS (not included Ceramic 50V Type)			PL051	3930060010	PILOT LAMP (14V, 200 mA)
C088	2561017019	0.01µF ±10% 630V METALLIZED	PL052	3930060010	PILOT LAMP (14V, 200 mA)
C089	2561017019	0.01µF ±10% 630V METALLIZED		2034146035	3P CONNECTOR CORD FOR POWER
C090	2561017019	0.01µF ±10% 630V METALLIZED		2034147034	3P CONNECTOR CORD FOR SP
C091	2561017019	0.01µF ±10% 630V METALLIZED		2036082045	4P CONNECTOR CORD FOR LCD
C092	2546058006	22000µF/22000µF 63V ELECTROLYTIC		2038091047	5P CONNECTOR CORD FOR LCD
C093	2546058006	22000µF/22000µF 63V ELECTROLYTIC		2040075051	6P CONNECTOR CORD FOR LCD
				4120952102	CONDENSER BRACKET
				4730354019	TAPPING SCREW (2)3x8
				1430231008	COLOR PLATE

• For PMA-750

ETC-454K (For E2), 454K (For EK), 454M (For E1) RECT & LCD UNIT

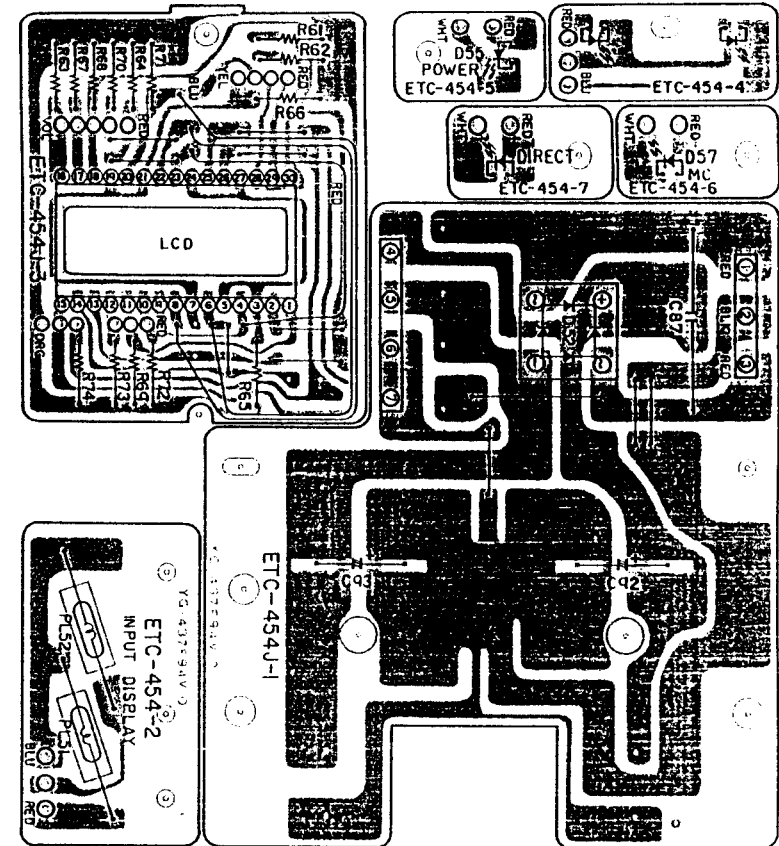

ETC-454K RECT & LCD UNIT PARTS LIST

Ref. No.	Part No.	Part Name & Descriptions	Ref. No.	Part No.	Part Name & Descriptions
SEMICONDUCTORS			OTHER PARTS		
D052	2760233005	M4C-51 DIODE		2220765000	P.W. BOARD
D053	3939149000	BG5531K GREEN LIGHT EMITTING DIODE		2050087039	3P TERMINAL
D054	3939149000	BG5531K GREEN LIGHT EMITTING DIODE		2050087042	4P TERMINAL
	3939149013	PR5531K RED LIGHT EMITTING DIODE		2090008133	JUMPER P=7.5mm USED 1
D055	3939149013	PR5531K RED LIGHT EMITTING DIODE		2090008120	JUMPER P=10mm USED 9
D056	3939149000	BG5531K GREEN LIGHT EMITTING DIODE	PL051	2090008162	JUMPER P=20mm USED 1
D057	3939149000	BG5531K GREEN LIGHT EMITTING DIODE	PL052	3930060010	PILOT LAMP (14 V, 200 mA)
	3939130006	LCD DISPLAY		3930060010	PILOT LAMP (14 V, 200 mA)
RESISTORS (not included Carbon Film ±5% ¼W Type)				2034146035	3P CONNECTOR CORD FOR POWER
CAPACITORS				2034147034	3P CONNECTOR CORD FOR SP
C087	2561017019	0.01µF ±10% 630V METALLIZED		2036082045	4P CONNECTOR CORD FOR LCD
C092	2546063004	15000/15000µF 63V ELECTROLYTIC		2038091047	5P CONNECTOR CORD FOR LCD
C093	2546063004	15000/15000µF 63V ELECTROLYTIC		2040075051	6P CONNECTOR CORD FOR LCD
				4120952102	CONDENSER BRACKET
				4730354019	TAPPING SCREW (2)3x8
				1430231008	COLOR PLATE

• For PMA-770
ETC-452B (For E2), 452D (For E1) INPUT & EQ. UNIT

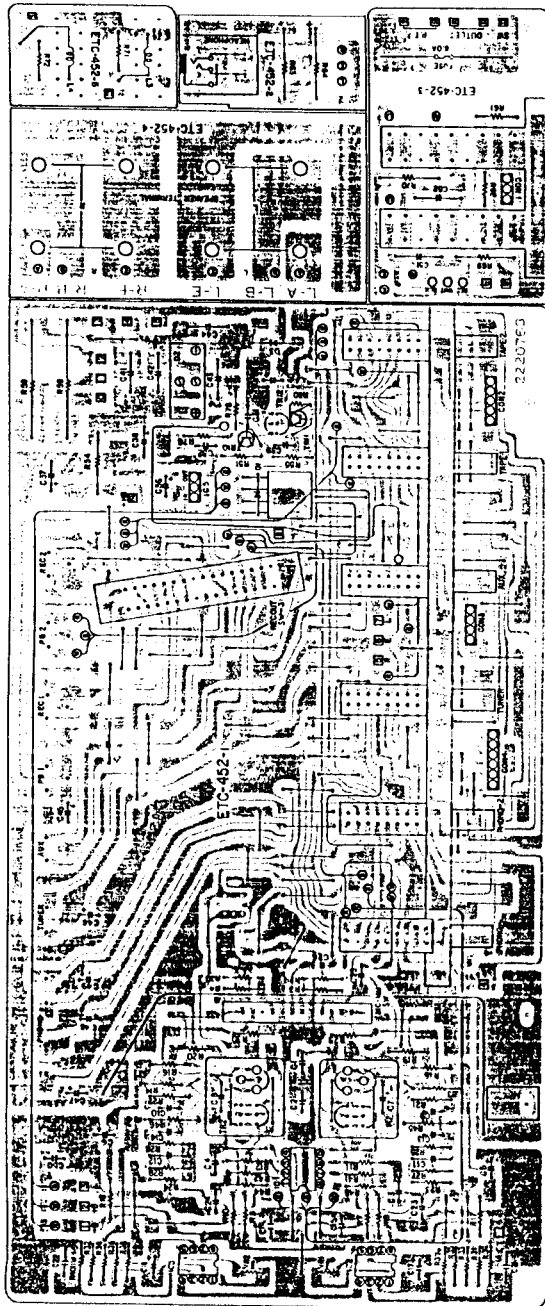

ETC-452B INPUT & EQ. UNIT PARTS LIST

Ref. No.	Part No.	Part Name & Descriptions	Ref. No.	Part No.	Part Name & Descriptions
SEMICONDUCTORS					
IC001	2850034013	NUM4559D INTEGRATED CIRCUIT	CO21	2554169000	0.01μF ±5% 50V PLASTIC FILM
IC002	2630133002	MPC741C INTEGRATED CIRCUIT	CO22	2554169000	0.01μF ±5% 50V PLASTIC FILM
IC003	2630133002	MPC741C INTEGRATED CIRCUIT	CO23	2554161008	0.0047μF ±5% 50V PLASTIC FILM
IC005	2630155006	μPC78M15 INTEGRATED CIRCUIT	CO24	2554161008	0.0047μF ±5% 50V PLASTIC FILM
TR001	2750029025	2SK240(BL)/(V) FIELD EFFECT TRANSISTOR	CO25	2554164005	0.0062μF ±5% 50V PLASTIC FILM
TR002	2750029025	2SK240(BL)/(V) FIELD EFFECT TRANSISTOR	CO26	2554164005	0.0062μF ±5% 50V PLASTIC FILM
TR003	2750029025	2SK240(BL)/(V) FIELD EFFECT TRANSISTOR	CO31	2539015001	0.1μF ±20% 25V CERAMIC
TR004	2750029025	2SK240(BL)/(V) FIELD EFFECT TRANSISTOR	CO32	2539015001	0.1μF ±20% 25V CERAMIC
TR010	2710102005	2SA1015(Y) TRANSISTOR	CO36	2544019005	220F 16V ELECTROLYTIC
TR011	2710105002	2SA966(Y) TRANSISTOR	CO37	2544079029	1000μF 25V ELECTROLYTIC
TR012	2750018010	2SK30A(O) FIELD EFFECT TRANSISTOR	CO38	2544041002	470μF 35V ELECTROLYTIC
D001	2760049008	1S2076 DIODE	CO39	2521018003	22pF ±5% 50V MICA FILM
D002	2760239009	1SRBA20F DIODE	CO40	2544039001	220μF 35V ELECTROLYTIC
D003	2760237001	RV06 DIODE	CO41	2554084020	0.068μF ±5% 100V PLASTIC FILM
RESISTORS (not included Carbon film ±5% ¼W Type)					
R021	2412018002	3.9 k ohm ±2% ¼W CARBON FILM	CO42	2554084020	0.068μF ±5% 100V PLASTIC FILM
R022	2412018002	3.9 k ohm ±2% ¼W CARBON FILM	CO43	2554084020	0.068μF ±5% 100V PLASTIC FILM
R025	2412032091	47 k ohm ±2% ¼W CARBON FILM	CO44	2554084020	0.068μF ±5% 100V PLASTIC FILM
R026	2412032091	47 k ohm ±2% ¼W CARBON FILM	CO45	2544043000	0.47μF 50V ELECTROLYTIC
R054	2440020020	18 ohm ±5% 1W METAL OXIDE FILM	CO46	2544043000	0.47μF 50V ELECTROLYTIC
R058	2440136024	39 ohm ±5% 3.15W METAL OXIDE FILM	CO47	2544043000	0.47μF 50V ELECTROLYTIC
R059	2440136024	39 ohm ±5% 3.15W METAL OXIDE FILM	CO48	2544043000	0.47μF 50V ELECTROLYTIC
R063	2440087021	120 ohm ±5% 2W METAL OXIDE FILM	CO49	2544043000	0.47μF 50V ELECTROLYTIC
R064	2440087021	120 ohm ±5% 2W METAL OXIDE FILM	CO50	2531024003	0.01μF +80,-20% 50V CERAMIC
R069	2440017020	10 ohm ±5% 1W METAL OXIDE FILM	CO51	2551121067	0.022μF ±5% 50V PLASTIC FILM
R070	2440017020	10 ohm ±5% 1W METAL OXIDE FILM	CO52	2551121067	0.022μF ±5% 50V PLASTIC FILM
R080	2442012023	4.7 ohm ±5% ¼W METAL OXIDE FILM	OTHER PARTS		
CAPACITORS (not included Ceramic 50 V Type)					
C001	2554123004	120pF ±5% 50V PLASTIC FILM	2220763109	P.W. BOARD	
C002	2554123004	120pF ±5% 50V PLASTIC FILM	2050134908	TERMINAL PIN USED 22	
C003	2554145008	0.001μF ±5% 50V PLASTIC FILM	2090047903	JUMPER WIRE USED 81	
C004	2554145008	0.001μF ±5% 50V PLASTIC FILM	EP 5667H11	TERMINAL USED 2	
C005	2544011003	220μF 10V ELECTROLYTIC	2090008133	JUMPER P=7.5mm USED 5	
C006	2544011003	220μF 10V ELECTROLYTIC	2090008120	JUMPER P=10mm USED 1	
C007	2541035008	1μF ±20% 35V ELECTROLYTIC	2090008117	JUMPER P=12.5mm USED 9	
C008	2541035008	1μF ±20% 35V ELECTROLYTIC	2090008146	JUMPER P=5mm USED 3	
C009	2554145008	0.001μF ±5% 50V PLASTIC FILM	FEP-1261	JUMPER WIRE USED 3	
C010	2554145008	0.001μF ±5% 50V PLASTIC FILM	VR001	2116014030 SEMI FIXED RESISTOR 100 k ohm	
C011	2554085032	0.068μF ±2% 50V PLASTIC FILM	VR002	2116014030 SEMI FIXED RESISTOR 100 k ohm	
C012	2554085032	0.068μF ±2% 50V PLASTIC FILM	LR001	2140020003 READ RELAY L23(M)	
C013	2554085016	0.018μF ±2% 50V PLASTIC FILM	4140116106	SHIELD COVER USED 2	
C014	2554085016	0.018μF ±2% 50V PLASTIC FILM	L003	INDUCTOR	
C017	2544010004	100μF 10V ELECTROLYTIC	L004	INDUCTOR	
C018	2544010004	100μF 10V ELECTROLYTIC	4170043100	RADIATOR	
			4730354019	TAPPING SCREW (213x8)	
			SW001	2124326105 6P PUSH SWITCH INPUT SELECTOR	
			SW002	2124330007 SLIDE SWITCH (4-2) REMOTE CARTRIDGE	
			SW003	2124331006 SLIDE SWITCH (4-6) REMOTE REC OUT	
			SW004	2124327007 2P PUSH SWITCH S.P. SWITCH	
				2048047007 HEADPHONE JACK	
				2050144008 8P TERMINAL FOR SP	
				2035622008 3P CONNECTOR BASE FOR SP LED	
				2035622024 4P MINI CON. PIN FOR LCD	
				2035622066 5P MINI CON. PIN FOR LCD	
				2035622082 6P CONNECTOR BASE FOR LCD	
				2050145007 4P CONNECTOR BASE FOR PHONO	
				2040079002 6P CONNECTOR BASE FOR AUX, TUN, TAPE	
				4140240001 EARTH PLATE	

• For PMA-750

ETC-452K (For E2, EK), 452M (For E1) INPUT & EQ. UNIT

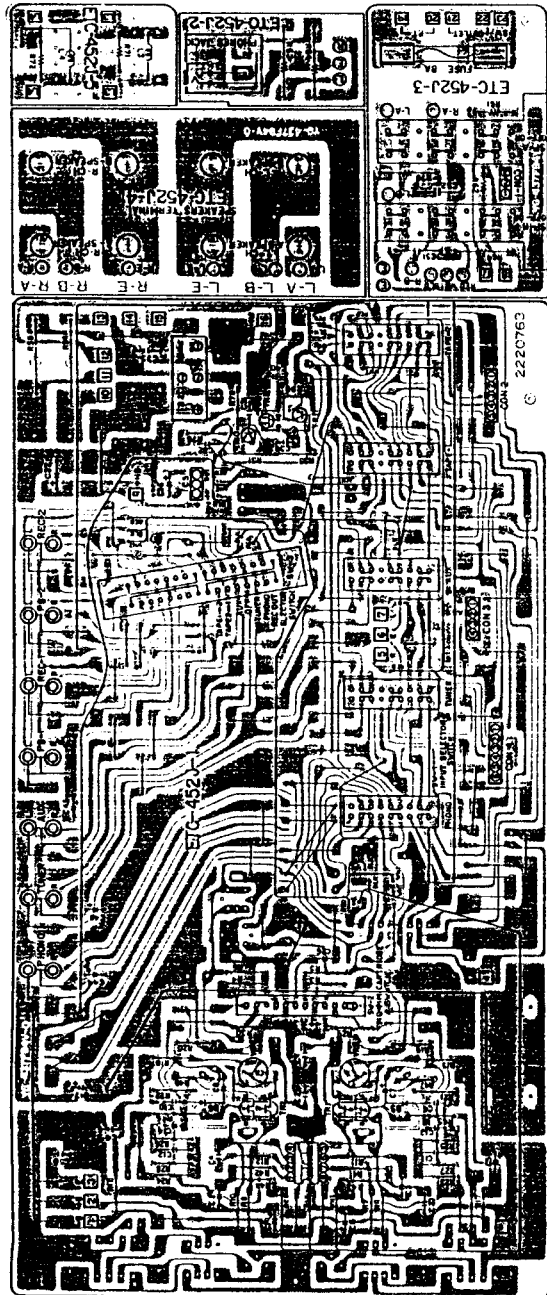

ETC-452K INPUT & EQ. UNIT PARTS LIST

Ref. No.	Part No.	Part Name & Descriptions	Ref. No.	Part No.	Part Name & Descriptions																																																																																										
SEMICONDUCTORS																																																																																															
IC001	2650034013	NJM4559D INTEGRATED CIRCUIT	C025	2554164005	0.0062 μ F ±5% 50V PLASTIC FILM																																																																																										
IC005	2630155006	μ PC78M15 INTEGRATED CIRCUIT	C026	2554164005	0.0062 μ F ±5% 50V PLASTIC FILM																																																																																										
TR001	2750029025	2SK240(BL)/(V) FIELD EFFECT TRANSISTOR	C031	2539015001	0.1 μ F ±20% 25V CERAMIC																																																																																										
TR002	2750029025	2SK240(BL)/(V) FIELD EFFECT TRANSISTOR	C032	2539015001	0.1 μ F ±20% 25V CERAMIC																																																																																										
TR010	2710102005	2SA1015(Y) TRANSISTOR	C035	2561017019	0.01 μ F ±10% 630V METALLIZED																																																																																										
TR011	2710105002	2SA966(Y) TRANSISTOR	C036	2544132005	10 μ F 16V ELECTROLYTIC																																																																																										
TR012	2750018010	2SK30A(O) FIELD EFFECT TRANSISTOR	C037	2544079029	1000 μ F 25V ELECTROLYTIC																																																																																										
D002	2760239009	S1RB20F DIODE	C040	2544039001	220 μ F 35V ELECTROLYTIC																																																																																										
D003	2760237001	RV06 DIODE	C045	2544145005	0.47 μ F 50V ELECTROLYTIC																																																																																										
D005	2760049008	1S2076 DIODE	C046	2544145005	0.47 μ F 50V ELECTROLYTIC																																																																																										
D006	2760049008	1S2076 DIODE	C047	2544145005	0.47 μ F 50V ELECTROLYTIC																																																																																										
RESISTORS (not included Carbon Film ±5% $\frac{1}{4}$ W Type)																																																																																															
R021	2412018002	3.9 k ohm ±2% $\frac{1}{4}$ W CARBON FILM	C049	2544145005	0.47 μ F 50V ELECTROLYTIC																																																																																										
R022	2412018002	3.9 k ohm ±2% $\frac{1}{4}$ W CARBON FILM	C051	2551121067	0.022 μ F ±5% 50V PLASTIC FILM																																																																																										
R025	2412032081	47 k ohm ±2% $\frac{1}{4}$ W CARBON FILM	C052	2551121067	0.022 μ F ±5% 50V PLASTIC FILM																																																																																										
R026	2412032081	47 k ohm ±2% $\frac{1}{4}$ W CARBON FILM	OTHER PARTS																																																																																												
R045	2420203003	10 M ohm ±10% $\frac{1}{4}$ W CARBON FILM	2220763109	P.W. BOARD																																																																																											
R046	2420203003	10 M ohm ±10% $\frac{1}{4}$ W CARBON FILM	2050134908	TERMINAL PIN USED 21																																																																																											
R058	2440077028	18 ohm ±5% 2W METAL OXIDE FILM	2090047903	JUMPER WIRE USED 76																																																																																											
R059	2440077028	18 ohm ±5% 2W METAL OXIDE FILM	EP-5667H1	TERMINAL USED 2																																																																																											
R063	2440029021	100 ohm ±5% 1W METAL OXIDE FILM	2090008146	JUMPER P=5mm USED 4																																																																																											
R064	2440029021	100 ohm ±5% 2W METAL OXIDE FILM	2090008133	JUMPER P=7.5mm USED 7																																																																																											
R069	2440017020	10 ohm ±5% 2W METAL OXIDE FILM	2090008120	JUMPER P=10mm USED 1																																																																																											
R070	2440017020	10 ohm ±5% 2W METAL OXIDE FILM	2090008117	JUMPER P=12.5mm USED 6																																																																																											
R080	2442012023	4.7 ohm ±5% $\frac{1}{4}$ W METAL OXIDE FILM	2090008104	JUMPER P=15mm USED 2																																																																																											
CAPACITORS (not included Ceramic 50V Type)																																																																																															
C005	2544131006	220 μ F 10V ELECTROLYTIC	2090008159	JUMPER P=17.5mm USED 1																																																																																											
C006	2544131006	220 μ F 10V ELECTROLYTIC	EP-5462H1	SOLID VR 100 ohm																																																																																											
C007	2541003001	10 μ F ±20% 6.3V ELECTROLYTIC	EP-5462H1	SOLID VR 100 ohm																																																																																											
C008	2541003001	10 μ F ±20% 6.3V ELECTROLYTIC	L003	2320017001 INDUCTOR																																																																																											
C009	2554145008	0.001 μ F ±5% 50V PLASTIC FILM	L004	2320017001 INDUCTOR																																																																																											
C010	2554145008	0.001 μ F ±5% 50V PLASTIC FILM	SW001	2124347100 5P PUSH SWITCH INPUT SELECTOR																																																																																											
C011	2554189006	0.068 μ F ±5% 50V PLASTIC FILM	SW002	2124330007 SLIDE SWITCH (4-2) REMOTE CARTRIDGE																																																																																											
C012	2554189006	0.068 μ F ±5% 50V PLASTIC FILM	SW003	2124331006 SLIDE SWITCH (4-6) REMOTE REC OUT																																																																																											
C013	2554175007	0.018 μ F ±5% 50V PLASTIC FILM	SW004	2124327007 2P PUSH SWITCH S.P.S.W.																																																																																											
C014	2554175007	0.018 μ F ±5% 50V PLASTIC FILM	2048047007	HEADPHONE JACK																																																																																											
C023	2551120084	0.0047 μ F ±5% 50V PLASTIC FILM	2050144008	8P TERMINAL																																																																																											
C024	2551120084	0.0047 μ F ±5% 50V PLASTIC FILM	2035622008	3P CONNECTOR BASE FOR SP LED																																																																																											
<table border="0" style="width: 100%;"> <tr> <td style="width: 20%;"></td> <td style="width: 20%;"></td> <td style="width: 20%;"></td> <td style="width: 20%;"></td> <td style="width: 20%;"></td> <td style="width: 20%;"></td> </tr> <tr> <td>VR001</td> <td>2220763109</td> <td>P.W. BOARD</td> <td>2050134908</td> <td>TERMINAL PIN USED 21</td> <td></td> </tr> <tr> <td>VR002</td> <td>2090047903</td> <td>JUMPER WIRE USED 76</td> <td>EP-5667H1</td> <td>TERMINAL USED 2</td> <td></td> </tr> <tr> <td>L003</td> <td>2090008146</td> <td>JUMPER P=5mm USED 4</td> <td>2090008133</td> <td>JUMPER P=7.5mm USED 7</td> <td></td> </tr> <tr> <td>L004</td> <td>2090008120</td> <td>JUMPER P=10mm USED 1</td> <td>2090008117</td> <td>JUMPER P=12.5mm USED 6</td> <td></td> </tr> <tr> <td></td> <td>2090008104</td> <td>JUMPER P=15mm USED 2</td> <td>2090008159</td> <td>JUMPER P=17.5mm USED 1</td> <td></td> </tr> <tr> <td></td> <td>EP-5462H1</td> <td>SOLID VR 100 ohm</td> <td>EP-5462H1</td> <td>SOLID VR 100 ohm</td> <td></td> </tr> <tr> <td></td> <td>L003</td> <td>2320017001 INDUCTOR</td> <td>L004</td> <td>2320017001 INDUCTOR</td> <td></td> </tr> <tr> <td></td> <td>SW001</td> <td>2124347100 5P PUSH SWITCH INPUT SELECTOR</td> <td>SW002</td> <td>2124330007 SLIDE SWITCH (4-2) REMOTE CARTRIDGE</td> <td></td> </tr> <tr> <td></td> <td>SW003</td> <td>2124331006 SLIDE SWITCH (4-6) REMOTE REC OUT</td> <td>SW004</td> <td>2124327007 2P PUSH SWITCH S.P.S.W.</td> <td></td> </tr> <tr> <td></td> <td>2048047007</td> <td>HEADPHONE JACK</td> <td>2050144008</td> <td>8P TERMINAL</td> <td></td> </tr> <tr> <td></td> <td>2035622008</td> <td>3P CONNECTOR BASE FOR SP LED</td> <td>2050136029</td> <td>4P CONNECTOR BASE FOR LCD</td> <td></td> </tr> <tr> <td></td> <td>2050136032</td> <td>5P CONNECTOR BASE FOR LCD</td> <td>2050136045</td> <td>6P CONNECTOR BASE FOR LCD</td> <td></td> </tr> <tr> <td></td> <td>2036084001</td> <td>4P CONNECTOR BASE FOR PHONO</td> <td>2040079002</td> <td>6P CONNECTOR BASE FOR AUX, TUN, TAPE</td> <td></td> </tr> <tr> <td></td> <td>4140240001</td> <td>EARTH PLATE</td> <td>FEPI261</td> <td>JUMPER WIRE USED 3</td> <td></td> </tr> </table>												VR001	2220763109	P.W. BOARD	2050134908	TERMINAL PIN USED 21		VR002	2090047903	JUMPER WIRE USED 76	EP-5667H1	TERMINAL USED 2		L003	2090008146	JUMPER P=5mm USED 4	2090008133	JUMPER P=7.5mm USED 7		L004	2090008120	JUMPER P=10mm USED 1	2090008117	JUMPER P=12.5mm USED 6			2090008104	JUMPER P=15mm USED 2	2090008159	JUMPER P=17.5mm USED 1			EP-5462H1	SOLID VR 100 ohm	EP-5462H1	SOLID VR 100 ohm			L003	2320017001 INDUCTOR	L004	2320017001 INDUCTOR			SW001	2124347100 5P PUSH SWITCH INPUT SELECTOR	SW002	2124330007 SLIDE SWITCH (4-2) REMOTE CARTRIDGE			SW003	2124331006 SLIDE SWITCH (4-6) REMOTE REC OUT	SW004	2124327007 2P PUSH SWITCH S.P.S.W.			2048047007	HEADPHONE JACK	2050144008	8P TERMINAL			2035622008	3P CONNECTOR BASE FOR SP LED	2050136029	4P CONNECTOR BASE FOR LCD			2050136032	5P CONNECTOR BASE FOR LCD	2050136045	6P CONNECTOR BASE FOR LCD			2036084001	4P CONNECTOR BASE FOR PHONO	2040079002	6P CONNECTOR BASE FOR AUX, TUN, TAPE			4140240001	EARTH PLATE	FEPI261	JUMPER WIRE USED 3	
VR001	2220763109	P.W. BOARD	2050134908	TERMINAL PIN USED 21																																																																																											
VR002	2090047903	JUMPER WIRE USED 76	EP-5667H1	TERMINAL USED 2																																																																																											
L003	2090008146	JUMPER P=5mm USED 4	2090008133	JUMPER P=7.5mm USED 7																																																																																											
L004	2090008120	JUMPER P=10mm USED 1	2090008117	JUMPER P=12.5mm USED 6																																																																																											
	2090008104	JUMPER P=15mm USED 2	2090008159	JUMPER P=17.5mm USED 1																																																																																											
	EP-5462H1	SOLID VR 100 ohm	EP-5462H1	SOLID VR 100 ohm																																																																																											
	L003	2320017001 INDUCTOR	L004	2320017001 INDUCTOR																																																																																											
	SW001	2124347100 5P PUSH SWITCH INPUT SELECTOR	SW002	2124330007 SLIDE SWITCH (4-2) REMOTE CARTRIDGE																																																																																											
	SW003	2124331006 SLIDE SWITCH (4-6) REMOTE REC OUT	SW004	2124327007 2P PUSH SWITCH S.P.S.W.																																																																																											
	2048047007	HEADPHONE JACK	2050144008	8P TERMINAL																																																																																											
	2035622008	3P CONNECTOR BASE FOR SP LED	2050136029	4P CONNECTOR BASE FOR LCD																																																																																											
	2050136032	5P CONNECTOR BASE FOR LCD	2050136045	6P CONNECTOR BASE FOR LCD																																																																																											
	2036084001	4P CONNECTOR BASE FOR PHONO	2040079002	6P CONNECTOR BASE FOR AUX, TUN, TAPE																																																																																											
	4140240001	EARTH PLATE	FEPI261	JUMPER WIRE USED 3																																																																																											

• For
ETI

• PMA-750

CONNECTION DIAGRAM

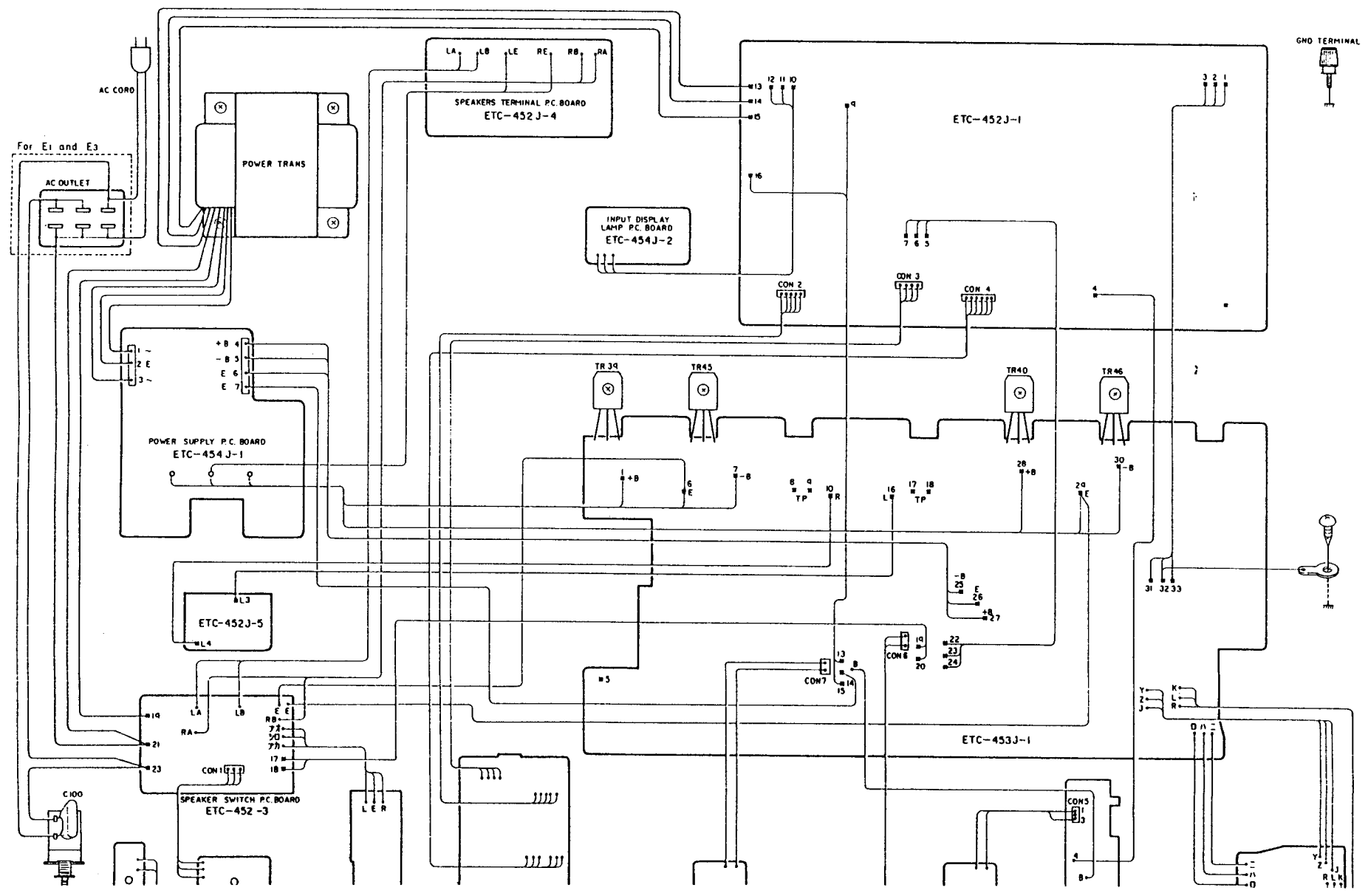

WIRING DIAGRAM

• PMA-750

△
whe
by tl

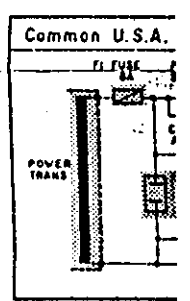
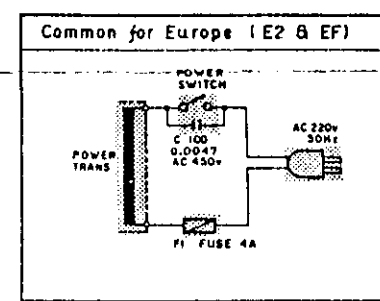
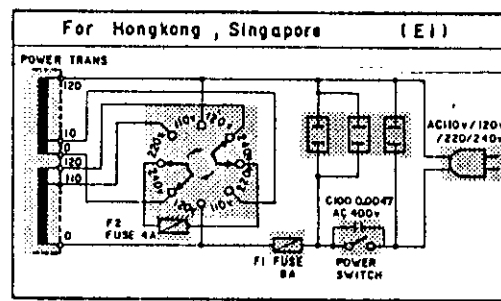
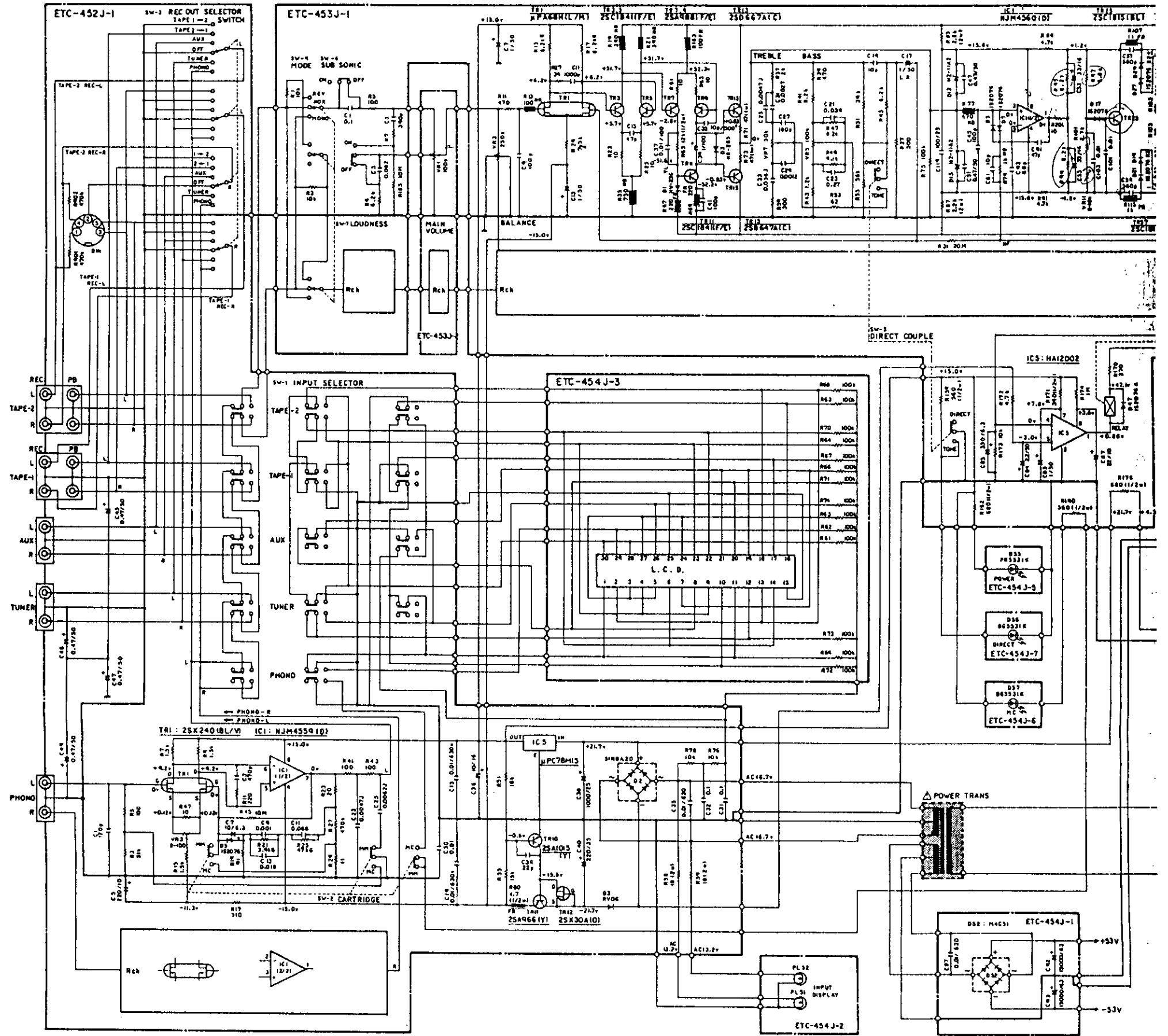

NOTES:

- All resistance values in ohm, K=1,000 ohm, M=1,000,000 ohm.
- All capacitance values in microfarad, P=micro-micro farad.
- Every voltages and currents is measured at no signal input condition.
- Circuit and parts are subject to change without prior notice.

Depending on the area, this circuit diagram varies as shown in the figure below.

NOTE:

- All voltage vs negative (-) p
- Checking of th and negative
- This schematic without notice

⚠ Means important safety item, which must be replaced, when necessary, by a part specified or meeting the specification by the manufacturer.

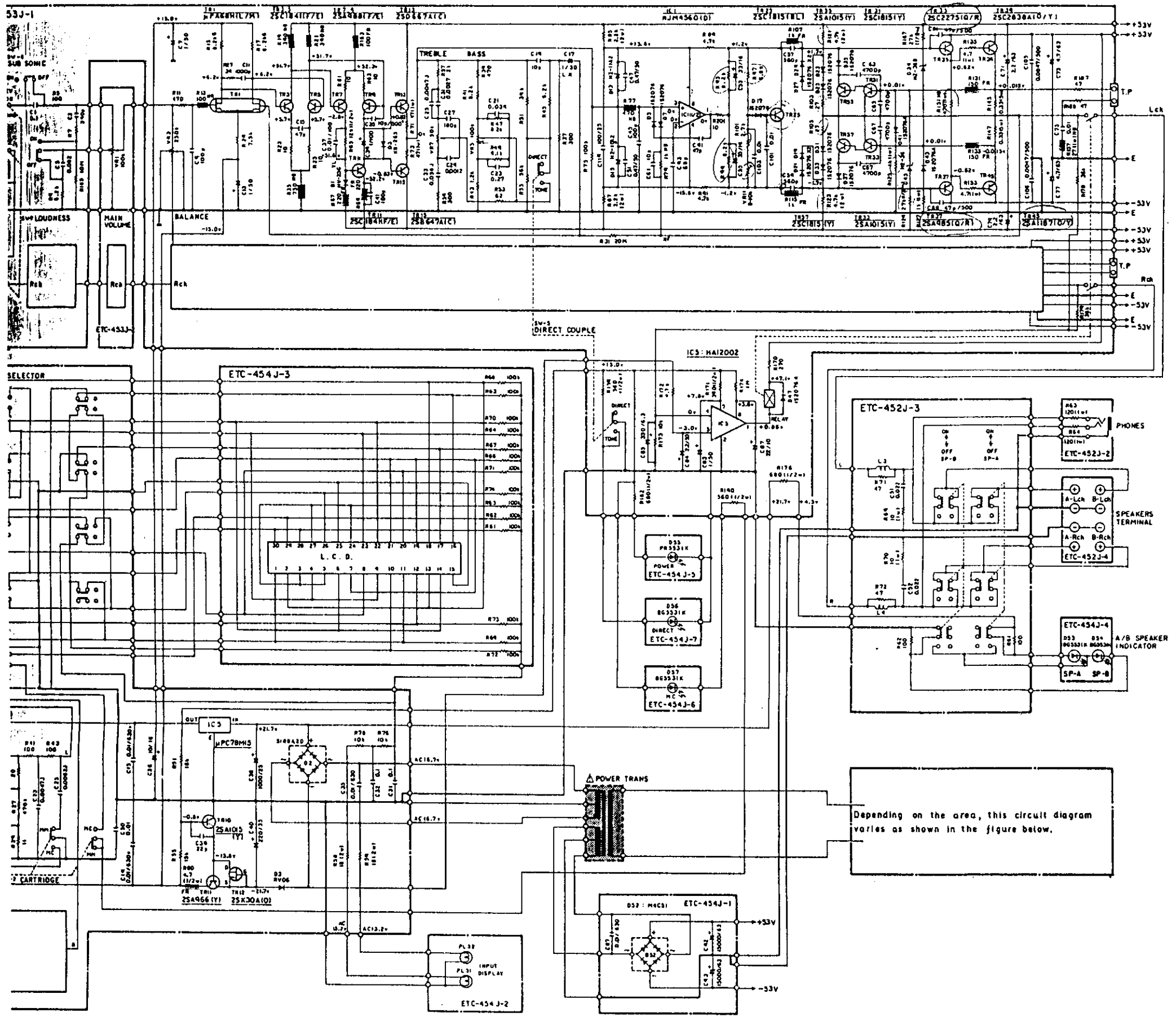

Depending on the area, this circuit diagram varies as shown in the figure below.

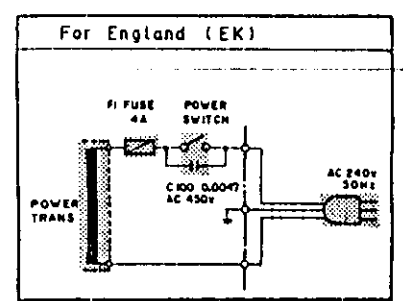
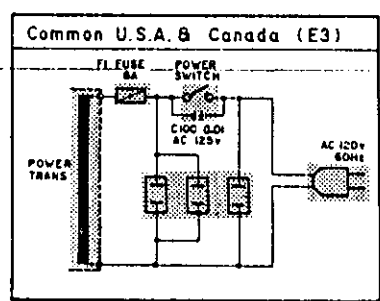
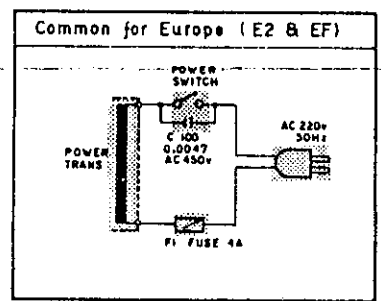
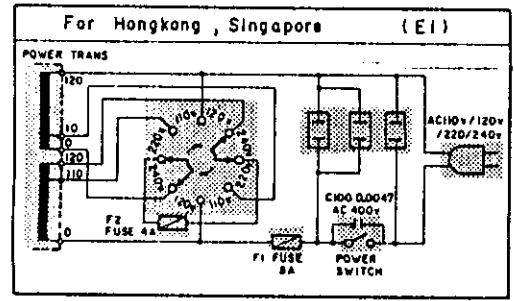

NOTES:
 All resistance values in ohm, K=1,000 ohm, M=1,000,000 ohm.
 All capacitance values in microfarad, P=micro-micro farad.
 Every voltages and currents is measured at no signal input condition.
 Circuit and parts are subject to change without prior notice.

Depending on the area, this circuit diagram varies as shown in the figure below.

NOTE:
 All voltage values in [] are measured between the specified points and negative (-) polarity power supply source.
 Checking of the value in [] must be measured between the specified point and negative (-) polarity power supply source, or damage may invite to the unit.
 This schematic diagram is standard and subject to change for Improvement without notice