

# DENON

Hi-Fi Pre-Main Amplifier

## SERVICE MANUAL MODEL PMA-777/757

SOLID STATE  
PRE MAIN AMPLIFIER

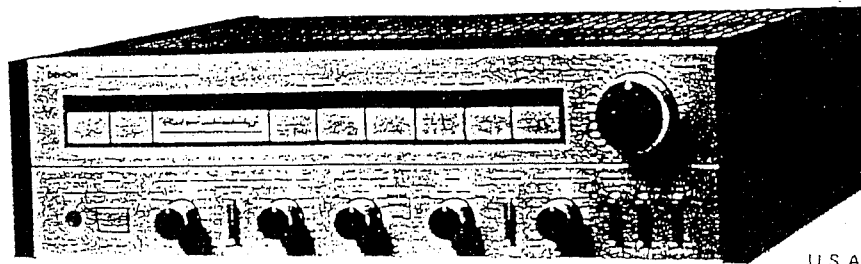

PMA-777

U.S.A. Version Only

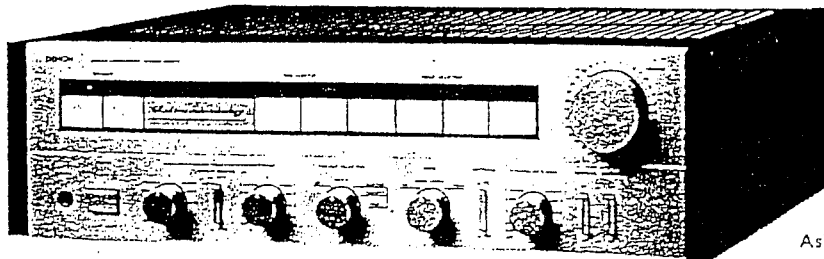

PMA-757

Asia Version Only

### CONTENTS

SPECIFICATIONS .....	2 ~ 3
CONTROLS AND FUNCTIONS .....	4
CONNECTIONS .....	5
METHOD OF ADJUSTMENT .....	6 ~ 7
BLOCK DIAGRAM .....	8
SEMICONDUCTORS .....	9
PRINTED WIRING BOARD PATTERNS AND PARTS LIST	
P.S & PROTECT UNIT ETC-0740, 0740B .....	10 ~ 11, 17
INPUT & EQ. UNIT ETC-0739, 0739B .....	12 ~ 13, 18 ~ 19
TONE & POWER UNIT ETC-0738, 0738B .....	14 ~ 15, 20 ~ 21
CONNECTION DIAGRAM .....	16, 22
WIRING DIAGRAM .....	23, 25
EXPLODED VIEW OF CHASSIS AND CABINET .....	24, 26

**NIPPON COLUMBIA CO., LTD**



**CAUTION**  
RISK OF ELECTRIC SHOCK  
DO NOT OPEN



CAUTION: TO REDUCE THE RISK OF ELECTRIC SHOCK, DO NOT REMOVE COVER (OR BACK). NO USER SERVICEABLE PARTS INSIDE. REFER SERVICING TO QUALIFIED SERVICE PERSONNEL.



The lightning flash with arrowhead symbol within an equilateral triangle is intended to alert the user of the presence of uninsulated "dangerous voltage" within the product's enclosure that may be of sufficient magnitude to constitute a risk of electric shock to persons.



The exclamation point within an equilateral triangle is intended to alert the user of the presence of important operating and maintenance (servicing) instruction in the literature accompanying the appliance.

**WARNING: TO PREVENT FIRE OR SHOCK HAZARD,  
DO NOT EXPOSE THIS APPLIANCE TO RAIN OR MOISTURE.**

**WARNING:**

**1. Component parts**

Parts marked with and/or shading in this service manual have special characteristics important to safety. Be sure to use the specified parts for replacement.

**2. Leakage current**

Before returning the appliance to customer, test the leakage current when the power plug is connected. Use a calibrated (with an error of not more than 5%) leakage current tester and measure the leakage current from any exposed metal to the earth ground. Reverse the power plug polarity and test the above again.

Any current measured MUST NOT EXCEED 0.5 milliamps. Corrective measure must be taken if it exceeds the limit.

**SPECIFICATIONS**

• PMA-777

**POWER AMPLIFIER SECTION**

**Rated Output Power:** Both channel drives (TUNER — SP OUT) 100 Watts minimum rms per channel (8 ohm Load) with less than 0.02% total harmonic distortion from 20 Hz to 20 kHz.  
120 W + 120 W (4 ohm Load)  
20 Hz to 20 kHz at T.H.D 0.05% (for U.S.A.)  
1 kHz (4 ohm Load) 150 W + 150 W (DIN, T.H.D 1%)  
1 kHz (4 ohm Load) 30 W + 30 W (IEC, Subject to change by temperature test.) (for outside U.S.A.)

**Total Harmonic Distortion:** 0.003% (20 Hz — 20 kHz at —3 dB rated output 8 ohm Load)  
0.02% (20 Hz — 20 kHz at rated output 8 ohm Load) (U.S.A.)

**Intermodulation Distortion:** Below 7 kHz/60 Hz: 1/4 0.002% (at amplitude output equivalent to rated output)

**Output Bandwidth: Transmission Characteristics:** 5 Hz — 80 kHz (IHF T.H.D 0.03%)  
1 Hz — 250 kHz <sup>+0</sup>/<sub>-3</sub> dB (at 1 W output)

**Input Sensitivity:** 150 mV  
**Input Impedance:** 47 k ohm  
**Output Impedance:** 0.08 ohm (1 kHz)  
**Output Terminals:** Speaker: A or B Load 4 — 16 ohm  
A + B Load 8 — 16 ohm  
Headphone/Stereo headphone (390 mW/ 8 ohm)

**EQUALIZER AMPLIFIER SECTION**

**Equalizer Amplifier Output:** Maximum Output: 12 V (at 47 k ohm Load)  
Rated Output: 150 mV  
Total harmonic distortion: less than 0.002% (at 1 kHz, 8 V output)

**Input Sensitivity/Input Impedance:** PHONO-1, 2 MM 2.5 mV 47 k ohm  
MC 200 μV 100 ohm  
TUNER 150 mV 47 k ohm  
DAD, VIDEO/AUX, TAPE 150 mV 47 k ohm  
**RIAA Deviation:** PHONO-1, 2 MM within ±0.2 dB (20 Hz — 100 kHz)  
MC within ±0.2 dB (20 Hz — 100 kHz)

**OVERALL CHARACTERISTICS**

**SN Ratio (IHFA Network):** PHONO-1, 2  
MM 88 dB (input terminals short-circuited for 2.5 mV input)  
MC 72 dB (input terminals short-circuited for 250 μV input)  
**TUNER, TAPE, DAD, VIDEO/AUX:** 110 dB (input terminals short-circuited)

**Tone Control Adjustable Range:** BASS 100 Hz ±8 dB  
TREBLE 10 kHz ±8 dB  
**Filtering Characteristics:** SUBSONIC 20 Hz, 6 dB/oct  
**Loudness Characteristics:** Low frequency 100 Hz + 7 dB  
High frequency 10 kHz + 6 dB

**AC OUTLET:** (For U.S.A., Canada and Asia)  
SWITCHED x 2, 100 W (Total)  
UNSWITCHED x 1, 250 W

• PMA-757

**POWER AMPLIFIER SECTION**

**Rated Output Power:** Both channel drives (TUNER — SP OUT) 80 Watts minimum rms per channel (8 ohm Load) with less than 0.02% total harmonic distortion from 20 Hz to 20 kHz.  
100 W + 100 W (4 ohm Load)  
20 Hz to 20 kHz at T.H.D. 0.05% (for U.S.A.)  
1 kHz (4 ohm Load) 110 W + 110 W (DIN, T.H.D 1%)  
1 kHz (4 ohm Load) 30 W + 30 W (IEC, Subject to change by temperature test.) (for outside U.S.A. and Canada)

**Total Harmonic Distortion:** 0.005% (20 Hz — 20 kHz at —3 dB rated output 8 ohms Load) 0.02% (20 Hz — 20 kHz at rated output 8 ohm Load) (U.S.A.)

**Intermodulation Distortion:** Below 7 kHz/60 Hz: 1/4 0.003% (at amplitude output equivalent to rated output)

**Output Bandwidth: Transmission Characteristics:** 5 Hz — 80 kHz (IHF T.H.D 0.03%)  
1 Hz — 200 kHz <sup>+0</sup>/<sub>-3</sub> dB (at 1 W output)  
**Input Sensitivity:** 150 mV  
**Input Impedance:** 47 k ohm  
**Output Impedance:** 0.08 ohm (1 kHz)  
**Output Terminals:** Speaker: A or B Load 4 — 16 ohm  
A + B Load 8 — 16 ohm  
Headphone/Stereo headphone (310 mW/ 8 ohm)

**EQUALIZER AMPLIFIER SECTION**

**Equalizer Amplifier Output:** Maximum Output: 12 V (at 47 k ohm Load)  
Rated Output: 150 mV  
Total harmonic distortion: less than 0.002% (at 1 kHz, 8 V output)

**Input Sensitivity/Input Impedance:** PHONO MM 2.5 mV 47 k ohm  
MC 200 μV 100 ohm  
TUNER 150 mV 47 k ohm  
DAD, VIDEO/AUX, TAPE 150 mV 47 k ohm

**NOTE:** The following code correspond to the appropriate models.  
E2 for Europe, E1 for Asia, E3 for U.S.A., EK for U.K., EA for Australia and EC for Canada.  
This Service Manual is prepared based on E2 Gold Version.

**POWER SOURCE:** Germany and France AC 220 V, 50 Hz;  
U.K. and Australia AC 240 V, 50 Hz;  
U.S.A. AC 120 V, 60 Hz; Asia 110/120/220/240 V, 50/60Hz (Multiple)  
**POWER CONSUMPTION:** 245 W (U.S.A.); 250 W (IEC); 220 W (Multiple) 800 W Maximum Output  
**DIMENSIONS:** 470 mm (18-1/2")W x 136 mm (5-11/32")H x 413 mm (16-1/4")D (with Wood Board)  
434 mm (17-5/64")W x 136 mm (5-11/32")H x 413 mm (16-1/4")D (without Wood Board) (including rubber feet, control knobs, and terminals.)  
**WEIGHT:** 12.5 kg (27 lbs 9 oz) (with Wood Board)  
11.5 kg (25 lbs 6 oz) (without Wood Board)

Design and specifications are subject to change without prior notice.

**RIAA Deviation:** PHONO MC within ±0.3 dB (20 Hz — 100 kHz)

**OVERALL CHARACTERISTICS**

**SN Ratio (IHFA Network):** PHONO  
MM 87 dB (input terminals short-circuited for 2.5 mV input)  
MC 70 dB (input terminals short-circuited for 250 μV input)  
**TUNER, TAPE, DAD, VIDEO/AUX:** 110 dB (input terminals short-circuited)

**Tone Control Adjustable Range:** BASS 100 Hz ±8 dB  
TREBLE 10 kHz ±8 dB  
**Filtering Characteristics:** SUBSONIC 20 Hz, 6 dB/oct  
**Loudness Characteristics:** Low frequency 100 Hz + 7 dB  
High frequency 10 kHz + 6 dB

**AC OUTLET:** (For U.S.A., Canada and Asia)  
SWITCHED x 2, 100 W (Total)  
UNSWITCHED x 1, 250 W

**POWER SOURCE:** Germany and France AC 220 V, 50 Hz;  
U.K. and Australia AC 240 V, 50 Hz;  
U.S.A. and Canada AC 120 V, 60 Hz;  
Asia 110/120/220/240 V, 50/60 Hz (Multiple)

**POWER CONSUMPTION:** 215 W (U.S.A.); 500 VA (Canada); 240 W (IEC); 190 W (Multiple); 650 W Maximum Output  
**DIMENSIONS:** 470 mm (18-1/2")W x 136 mm (5-11/32")H x 413 mm (16-1/4")D (with Wood Board)  
434 mm (17-5/64")W x 136 mm (5-11/32")H x 413 mm (16-1/4")D (without Wood Board) (including rubber feet, control knobs, and terminals.)

**WEIGHT:** 13 kg (28 lbs 11 oz) (with Wood Board)  
12 kg (26 lbs 7 oz) (without Wood Board)  
10.5 kg (23 lbs 2 oz) (without Wood Board) (For U.S.A. & Canada)

Design and specifications are subject to change without prior notice.

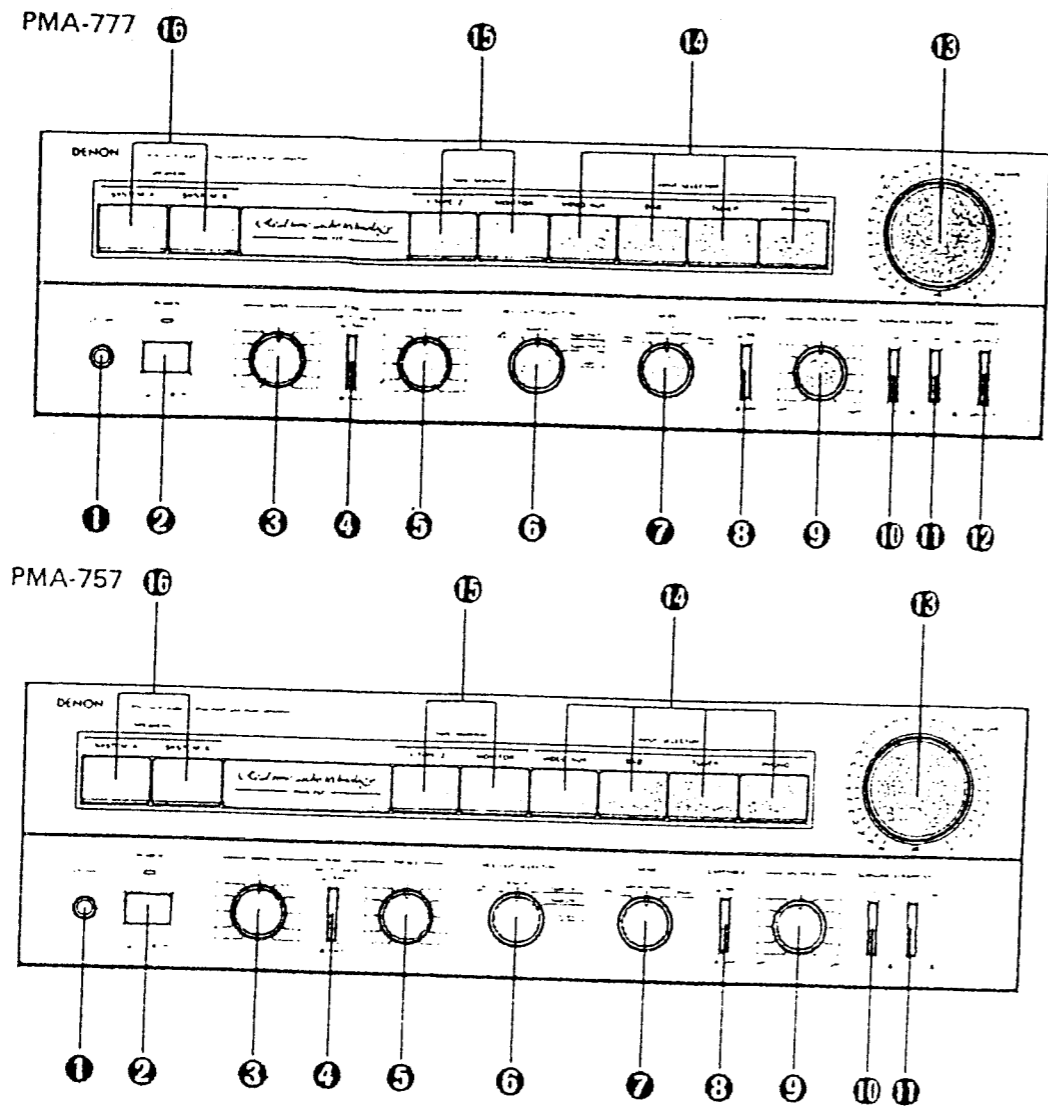
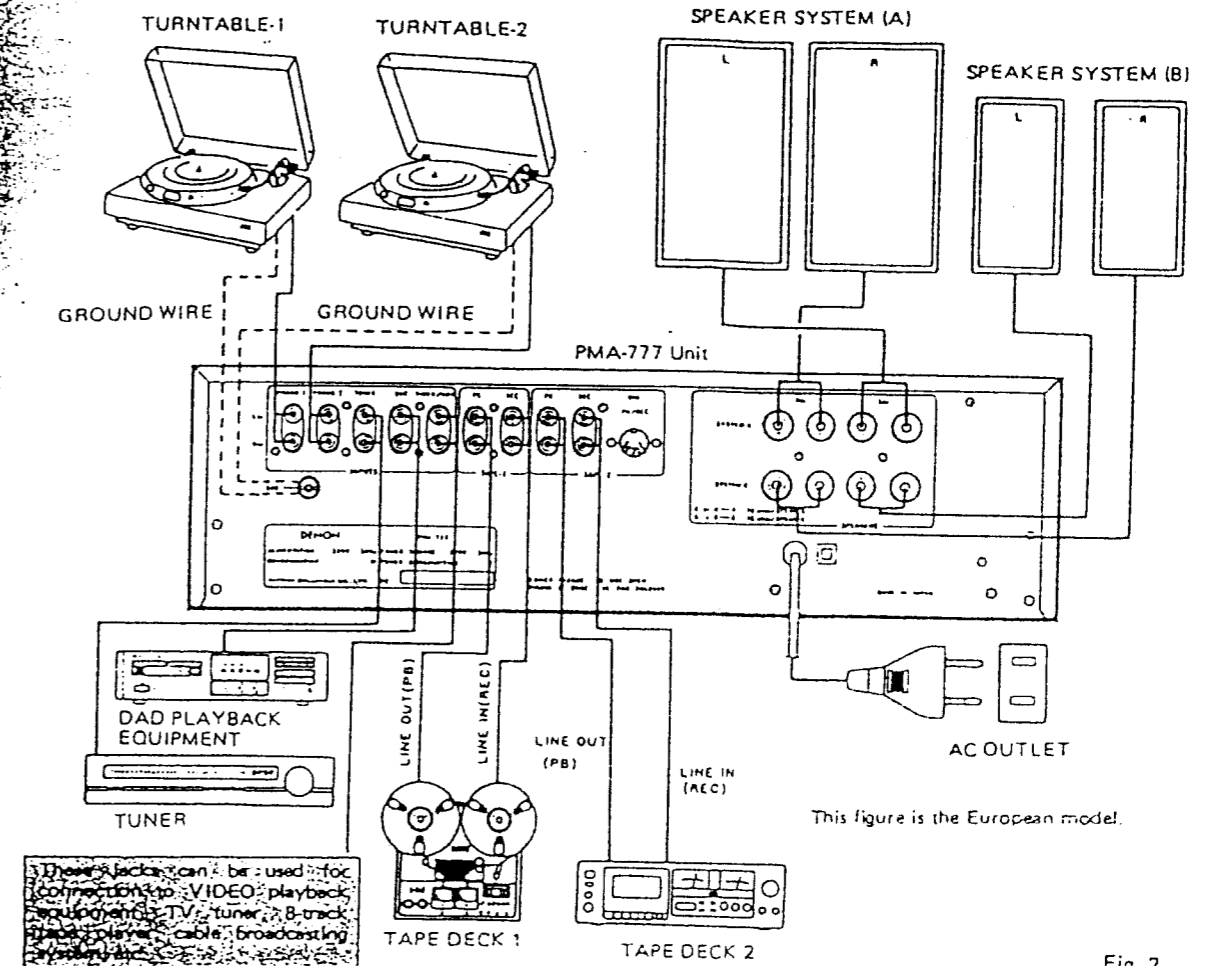

Fig. 1

- |   |   |
|---|---|
| <p>① phones (Headphone Jack)</p> <p>② POWER &amp; LED Indicator (Power Switch and LED Indicator)</p> <p>③ BASS (Bass Control)</p> <p>④ DIRECT COUPLE (Direct Coupling Switch)</p> <p>⑤ TREBLE (Treble Control)</p> <p>⑥ REC OUT SELECTOR (REC OUT Selector Switch)<br/>off, source, tape 1 ▶ 2, tape 2 ▶ 1</p> <p>⑦ MODE (Mode Switch)<br/>rev. stereo normal, mono</p> <p>⑧ CARTRIDGE (Cartridge Select Switch)<br/>— MC, — MM</p> | <p>⑨ BALANCE (Balance Control)</p> <p>⑩ SUBSONIC (Subsonic Filter Switch)</p> <p>⑪ LOUDNESS (Loudness Switch)</p> <p>⑫ PHONO (Turntable Select Switch)<br/>... only for PMA-777<br/>— Phono 1, — Phono 2</p> <p>⑬ VOLUME (Volume Control)</p> <p>⑭ INPUT SELECTOR (Input Selector Switch)<br/>PHONO, TUNER, DAD, VIDEO/AUX</p> <p>⑮ TAPE MONITOR (Tape Monitor Switch)</p> <p>⑯ SPEAKERS (Speaker Select Switch)<br/>SYSTEM A, SYSTEM B</p> |
|---|---|



This figure is the European model.

Fig. 2

- (1) CONNECTIONS
- Do not plug power cord into AC outlet until all connections are completed.
  - Connect right (R) channel plug to right (R) channel jack, and left channel plug to left channel jack.
  - Insert plugs firmly into corresponding jacks. If connection is incomplete, noise may be generated.
  - Plug audio component power cords into AC OUTLET terminal. Do not use this terminal for other electrical appliances, such as hair dryers. (NOT INCLUDED IN SYSTEMS FOR USE IN EUROPE AND AUSTRALIA)
  - Do not bundle pin plug cords with power cord. Do not place pin plug cords near power transformer, or hum and other noise may occur.
  - Always connect a pin plug cord or shorting pins to "PHONO" input terminals because these terminals are highly sensitive. If these terminals are not connected, induction hum may occur.
- (2) AC OUTLETS (NOT INCLUDED IN SYSTEMS FOR USE IN EUROPE AND AUSTRALIA)  
AC outlets are used for connecting amplifier component units, such as tuner, turntable, tape deck, etc.
- SWITCHED (Capacity: 100 W):  
This outlet is turned on/off when main power switch is turned on/off.
  - UNSWITCHED (Total capacity: 250 W):  
These outlets are always ON whether power switch is on or off.
- (3) LINE VOLTAGE (Voltage select switch) ... NOT INCLUDED IN SYSTEMS FOR USE IN EUROPE, U.S.A., CANADA AND AUSTRALIA
- The desired voltage may be set with the VOLTAGE SELECTOR KNOB on the back panel using a screw driver.
  - Do not twist the VOLTAGE SELECTOR KNOB with excessive force. It may be damaged.
  - If the voltage select switch does not turn smoothly, see a qualified serviceman.

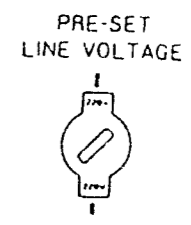

Fig. 3

METHOD OF ADJUSTMENTS

Carry out adjustment at room temperature and normal humidity with the power source operating at the rated voltage.

ADJUSTMENT OF IDLING CURRENT (ETC0738, ETC0738B) - Fig. 4

Preparation

- 1 Place the unit in normal operating condition, avoid such good ventilating location close to air conditioner, circulating fan, etc.

The unit circumference temperature must be in 15° ~ 30°C.

2 Set the switches as follows:

- POWER SWITCH → OFF
- VOLUME CONTROL → -∞ (∞)
- DIRECT COUPLE → DIRECT
- SPEAKER TERMINAL → No load (Do not connect speakers, dummy resistors.)

Adjustment

- 1 Remove top cover and rotate VR301 (Lch) counterclockwise (∞) and VR302 (Rch) clockwise (∞) on the ETC-738. Connect a DC voltmeter to the test point (Lch TP-1, 2 and Rch TP-3, 4).
- 2 Connect the power cord and turn the POWER switch on. Immediately after turning on the power, rotate VR301 clockwise (∞), VR302 counterclockwise (∞) and adjust the test point voltage value -  
 PMA-777: 2 mV ± 0.2 mV DC  
 PMA-757: 5 mV ± 0.2 mV DC
- 3 3 minutes after the preparatory adjustment as in step 2, rotate VR301, VR302 and obtain the voltage value -  
 PMA-777: 11 mV ± 2 mV DC  
 PMA-757: 13 mV ± 0.5 mV DC

CAUTION

VR301 and VR302 of the present model have opposite turning directions in adjustment. In the future by changing of the board, adjustment of VR302 will be the same manner as of VR301. Therefore after the board has changed (222 1090 208), adjust the VR302 with the possible care.

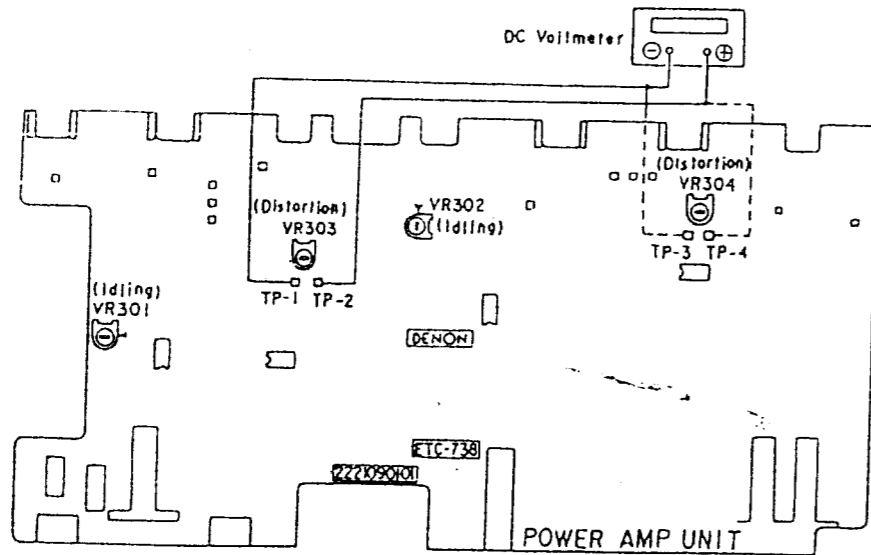

Fig. 4

ADJUSTMENT OF DISTORTION FACTOR (Fig. 4)

- 1 Connect a 8-ohm loading resistor across the speaker terminal.
- 2 Inject 20 kHz sine wave signal through the TUNER terminal. Operate both L and R channels and obtain 50 watts (20 Wrms) output power across the 8-ohm loading resistor.
- 3 Adjust VR303 (Lch) and VR304 (Rch) for minimum distortion factor (be sure to put bottom cover to the unit during the adjustment).

ADJUSTMENT OF NEUTRAL POTENTIAL POINT (Fig. 5, Fig. 5')

Preparation

- 1 Insert the shorting pin into the PHONO input terminal.
- 2 Connect a digital voltmeter (be able to measure 0.01 mV through 1 mV DC) to the REC output (Lch and Rch).
- 3 Connect a 100-k ohm (1/4 watt or so) resistor across the test point (Lch TP-3, 4 and Rch TP-5, 6) on the EQ Amp unit.

4 Set the switches as follows:

- INPUT SELECTOR → PHONO
- REC OUT SELECTOR → Source
- CARTRIDGE → MM
- VOLUME CONTROL → -∞ (∞)

Adjustment

- 1 Approximately 2 minutes after turning on the POWER switch, rotate - VR103 (PMA-777), VR101 (PMA-757) and adjust the Lch digital meter reading for 0.5 mV DC or less value.
- 2 In the same manner rotate - VR104 (PMA-777), VR102 (PMA-757) and adjust the Rch digital meter reading for 0.5 mV DC or less value.

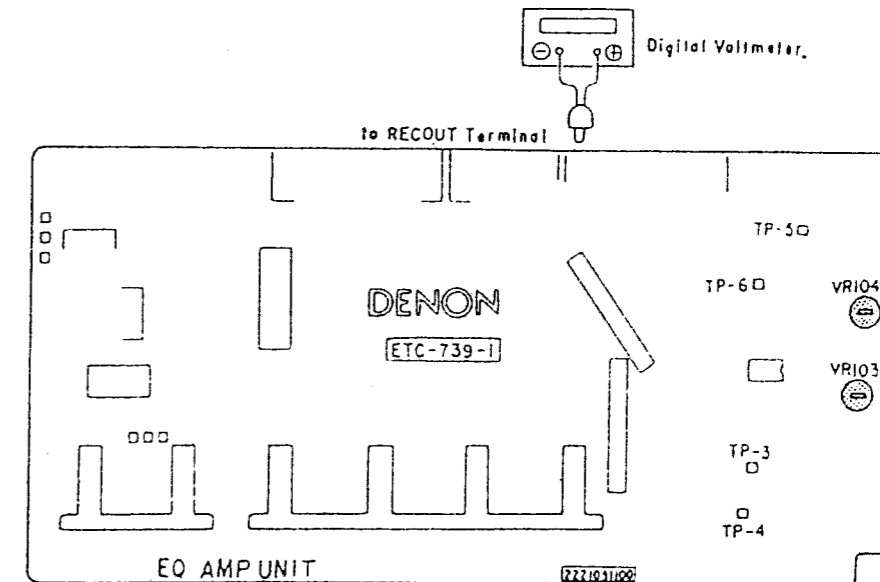

Fig. 5  
for : PMA-777

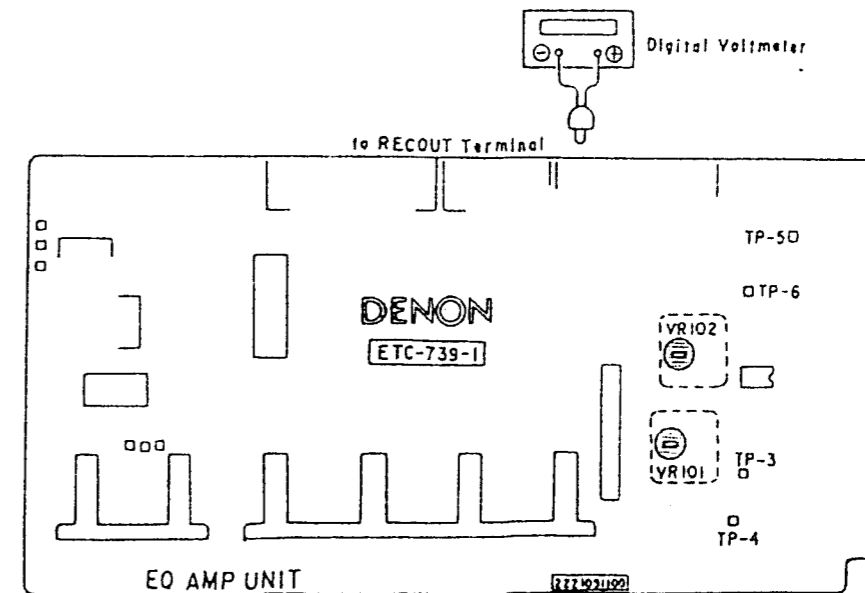
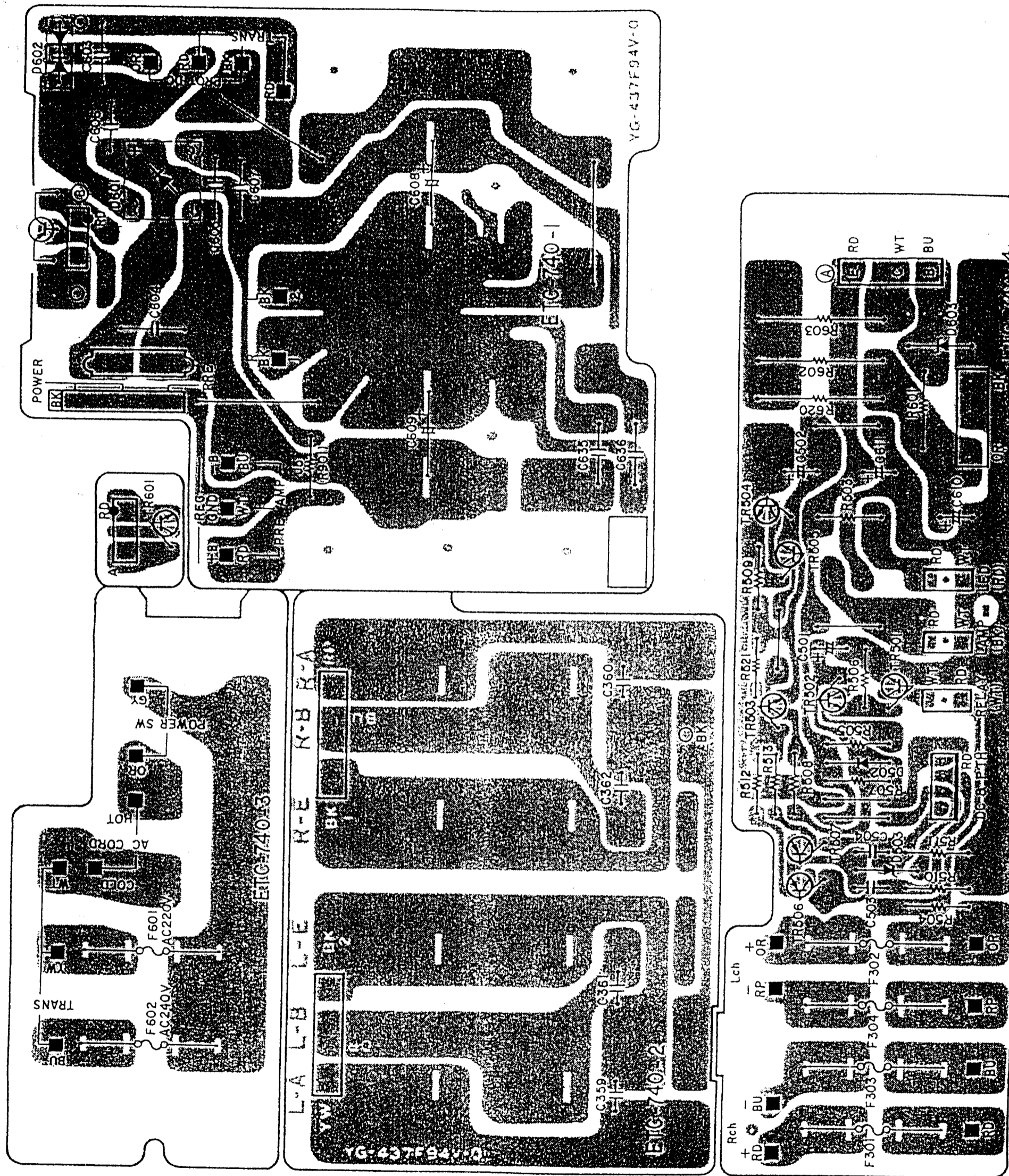

Fig. 5'  
for : PMA-757

• PMA-777

# ETC0740 P.S & PROTECT UNIT



ETC0739 INPUT & EQ. UNIT PARTS LIST

Table with 3 columns: Ref. No., Part No., Part Name & Descriptions. Includes sections for SEMICONDUCTORS, RESISTORS, CAPACITORS, and OTHER PARTS.

Table with 3 columns: Ref. No., Part No., Part Name & Descriptions. Includes sections for SWITCHES, OTHER PARTS, and FUSE.

PRINTED WIRING BOARD PATTERNS AND PARTS LIST

ETC0740 P.S. & PROTECT UNIT PARTS LIST

Table with 3 columns: Ref. No., Part No., Part Name & Descriptions. Includes sections for SEMICONDUCTORS, RESISTORS, CAPACITORS, FUSE, and OTHER PARTS.

Table with 3 columns: Ref. No., Part No., Part Name & Descriptions. Lists various electronic components like JUMPER WIRE, CONNECTOR CORD, CONDENSER BRACKET, etc.

ETC0740D E1 for Asia (Same as ETC0740 except the followings.)

Table with 3 columns: Ref. No., Part No., Part Name & Descriptions. Lists components with deletion notes like (DELETE).

ETC0740E E3 for U.S.A. (Same as ETC0740 except the followings.)

Table with 3 columns: Ref. No., Part No., Part Name & Descriptions. Lists components with deletion and change notes like (DELETE) and (CHANGE).

ETC0740E EA for Australia and EK for U.K. (Same as ETC0740 except the followings.)

Table with 3 columns: Ref. No., Part No., Part Name & Descriptions. Lists components with deletion and addition notes like (DELETE) and (ADD).

1 for Asia  
0739 except the followings.)

• PMA-777  
ETC0739 INPUT & EQ. UNIT

No.	Part Name & Descriptions
RESISTORS	
6003	470k ohm ±5% 1/4W CARBON (DELETE)
8120	JUMPER WIRE P-10mm (CHANGE)
CAPACITORS	
2001	430pF ±5% 50V CERAMIC (DELETE)
3000	470pF ±5% 50V CERAMIC (DELETE)
5008	560pF ±5% 50V CERAMIC (DELETE)
4003	0.01μF +80,-20% 50V CERAMIC (DELETE)
5004	240pF ±5% 50V CERAMIC (DELETE)
6005	47pF ±5% 50V CERAMIC (CHANGE)
OTHER PARTS	
6008	DIN JACK (5P) (DELETE)
8120	JUMPER WIRE P-10mm USED 102 (CHANGE)

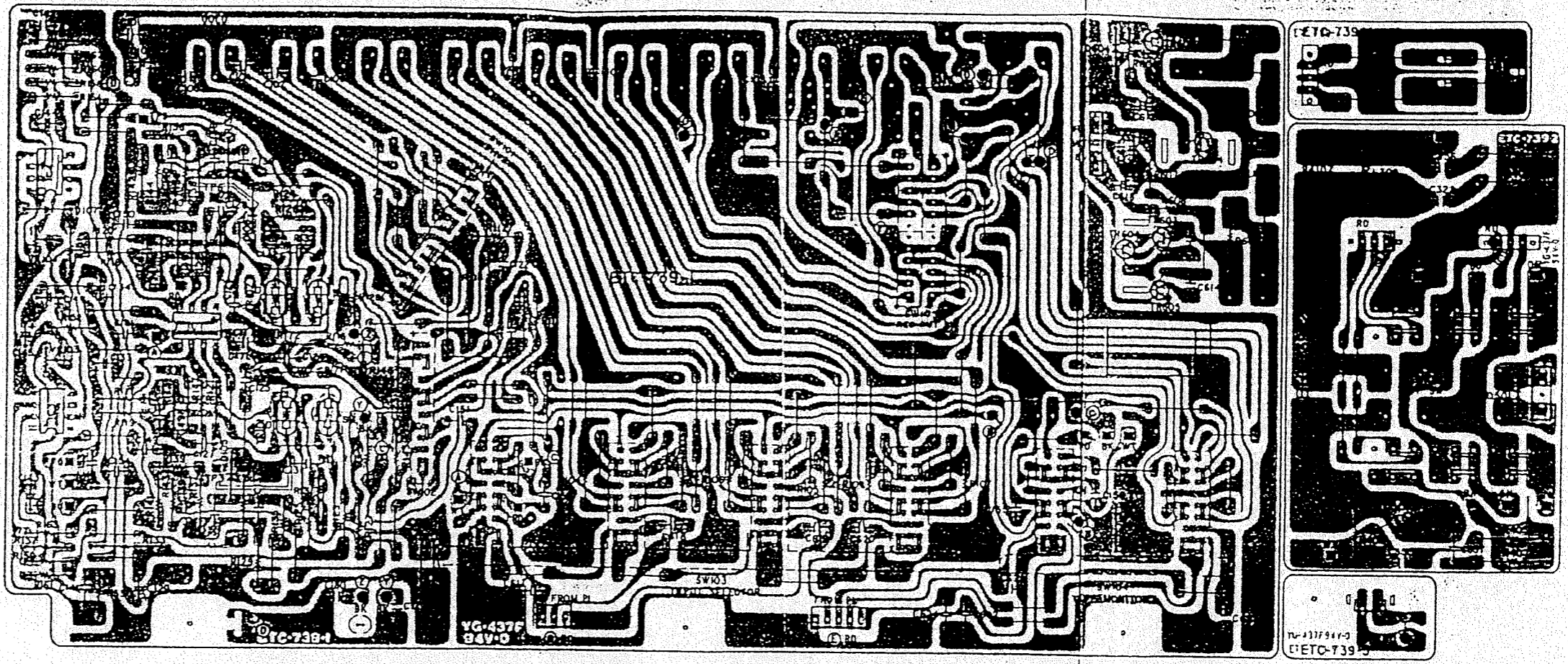
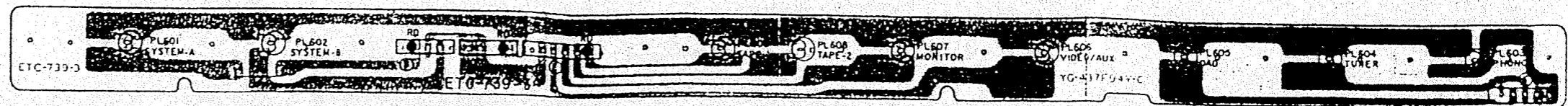

for U.S.A.  
739 except the followings.)

ETC0739F EA for Australia and EK for U.K.  
(Same as ETC0739 except the followings.)

No.	Part Name & Descriptions
RESISTORS	
6003	470k ohm ±5% 1/4W CARBON (DELETE)
8120	JUMPER WIRE P-10mm (CHANGE)
CAPACITORS	
6001	430pF ±5% 1/4W CERAMIC (DELETE)
6003	0.01μF +80,-20% 50V CERAMIC (CHANGE)

Ref. No.	Part No.	Part Name & Descriptions
C155, 156	2533643000	470pF ±5% 50V CERAMIC (DELETE)
C171, 172	2533636004	240pF ±5% 50V CERAMIC (DELETE)
C125, 126	2533645008	560pF ±5% 50V CERAMIC (CHANGE)
C173, 174	2533619005	47pF ±5% 50V CERAMIC (CHANGE)
OTHER PARTS		
	2048059008	DIN JACK (5P) (DELETE)
	2090008120	JUMPER WIRE P-10mm USED 102 (CHANGE)

Ref. No.	Part No.	Part Name & Descriptions
RESISTORS		
R171, 172	2090008120	JUMPER WIRE P-10mm (CHANGE)
CAPACITORS		
C104 ~107	2533642001	430pF ±5% 50V CERAMIC (DELETE)
C178, 179, 180	2531024003	0.01μF +80,-20% 50V CERAMIC (CHANGE)

Ref. No.	Part No.	Part Name & Descriptions
C155, 156	2533643000	470pF ±5% 50V CERAMIC (DELETE)
171, 172	2533636004	240pF ±5% 50V CERAMIC (DELETE)
C125, 126	2533645008	560pF ±5% 50V CERAMIC (CHANGE)
C173, 174	2533619005	47pF ±5% 50V CERAMIC (CHANGE)
OTHER PART		
	2090008120	JUMPER WIRE P-10mm USED 102 (CHANGE)

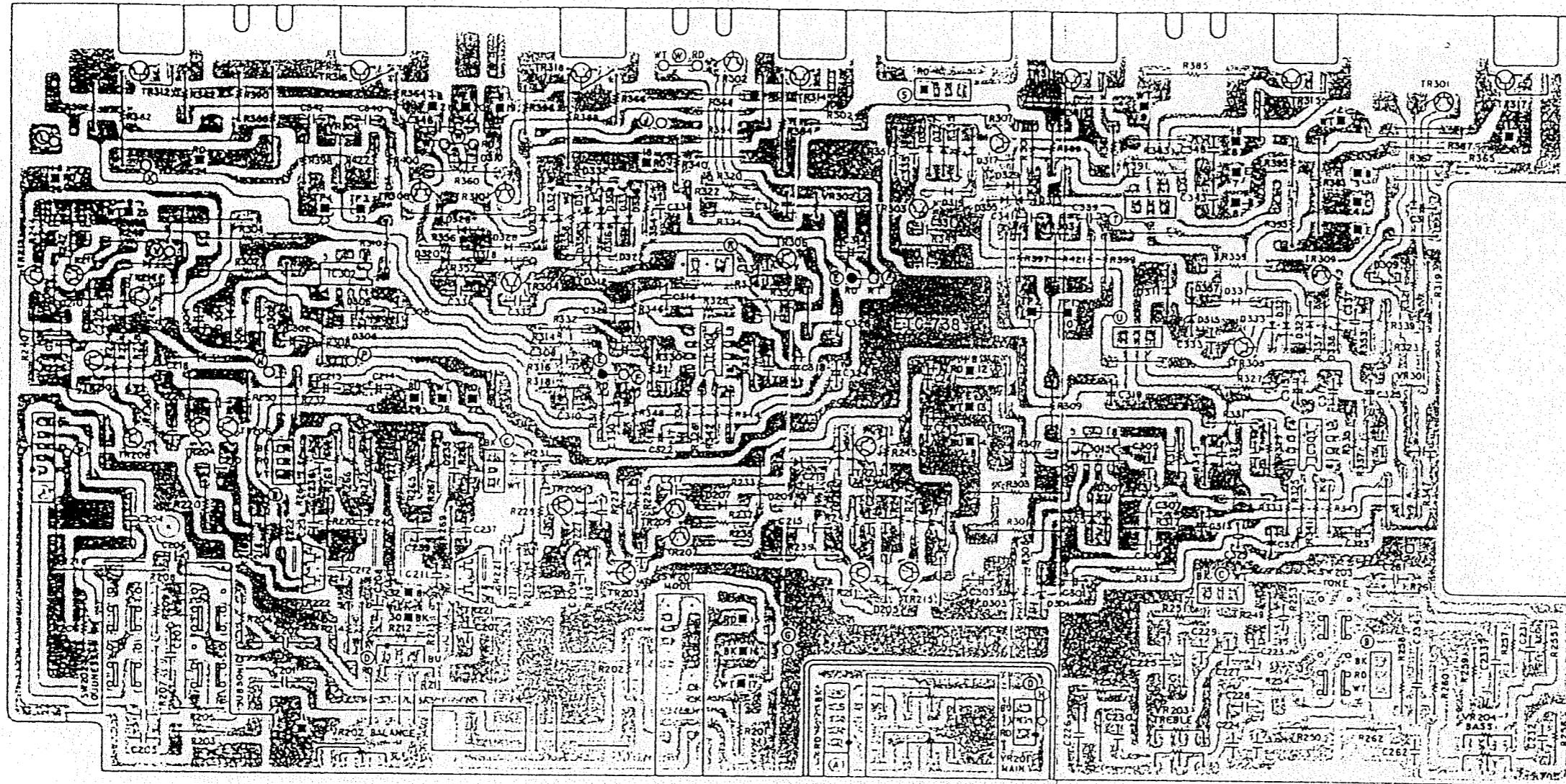

ETC0738 TONE & POWER UNIT PARTS LIST

Ref. No.	Part No.	Part Name & Descriptions
SEMICONDUCTORS		
TR221, 222	2750046008	2SK170(BL)/(V)OVGS FET
IC301	2630257001	M-5218P (MITSUBISHI) IC
-304		
TR201, 202	2750046008	2SK170(BL)/(V)OVGS FET
TR203	2730235020	2SC1841(E/F) TRANSISTOR
-206		
TR207	2710185006	2SA949(O)/(Y) TRANSISTOR
-210		
TR211	2730307000	2SC2229(O)/(Y) TRANSISTOR
-214		
TR215, 216	2710185006	2SA949(O)/(Y) TRANSISTOR
TR301, 302	2730198015	2SC1815(BL) TRANSISTOR
TR303, 304	2730307000	2SC2229(O)/(Y) TRANSISTOR
TR305, 306	2710185006	2SA949(O)/(Y) TRANSISTOR
TR307, 308	2730199027	2SC2238(Y)/(O) TRANSISTOR
TR309, 310	2710104029	2SA968(Y)/(O) TRANSISTOR
D205	2760049008	1S2076 DIODE
-210		
D301	2760253001	HZ15-2 ZENER
-304		
D305	2760049008	1S2076 DIODE
-308		
D309, 310	2760388002	MV-1YH DIODE
D311, 312	2760236031	HZ5C-1 ZENER
D313	2760052053	HZ11B-1 ZENER
-316		
D317	2760049008	1S2076 DIODE
-336		
D355	2760049008	1S2076 DIODE
-358		
RESISTORS (not included Carbon Film ±5%, 1/4W Type)		
R209, 210	2420203003	10M ohm ±10% 1/4W CARBON COMPOSIT
AR211	2412314023	470 ohm ±5% 1/4W CARBON (NB)
AR212	2412314023	470 ohm ±5% 1/4W CARBON (NB)
AR223	2412314023	470 ohm ±5% 1/4W CARBON (NB)
AR228	2412314023	470 ohm ±5% 1/4W CARBON (NB)
AR231	2412314023	470 ohm ±5% 1/4W CARBON (NB)
AR232	2412314023	470 ohm ±5% 1/4W CARBON (NB)
AR233	2412314023	470 ohm ±5% 1/4W CARBON (NB)
AR234	2412314023	470 ohm ±5% 1/4W CARBON (NB)
AR238	2410054025	120 ohm ±5% 1/4W METAL OXIDE (NB)
AR240	2410054025	120 ohm ±5% 1/4W METAL OXIDE (NB)
AR241	2412314023	470 ohm ±5% 1/4W CARBON (NB)
AR242	2412314023	470 ohm ±5% 1/4W CARBON (NB)
AR245	2412321016	22 ohm ±5% 1/4W CARBON (NB)
AR248	2412321016	22 ohm ±5% 1/4W CARBON (NB)
AR301	2440103028	27K ohm ±5% 1/2W METAL OXIDE (NB)
AR304	2412321016	22 ohm ±5% 1/4W CARBON (NB)
AR305	2412321016	22 ohm ±5% 1/4W CARBON (NB)
AR308	2412321016	22 ohm ±5% 1/4W CARBON (NB)
AR309	2412321003	1K ohm ±5% 1/4W CARBON (NB)
AR310	2412321003	1K ohm ±5% 1/4W CARBON (NB)

ETC0738E E3 for U.S.A.  
(Same as ETC0738 except the followings.)

Ref. No.	Part No.	Part Name & Descriptions
CAPACITORS		
C241, 243	2544203002	1μF ±20% 160V ELECTROLYTIC (CHANGE)



CONNECTION DIAGRAM

• PMA-777

This figure is E2 version

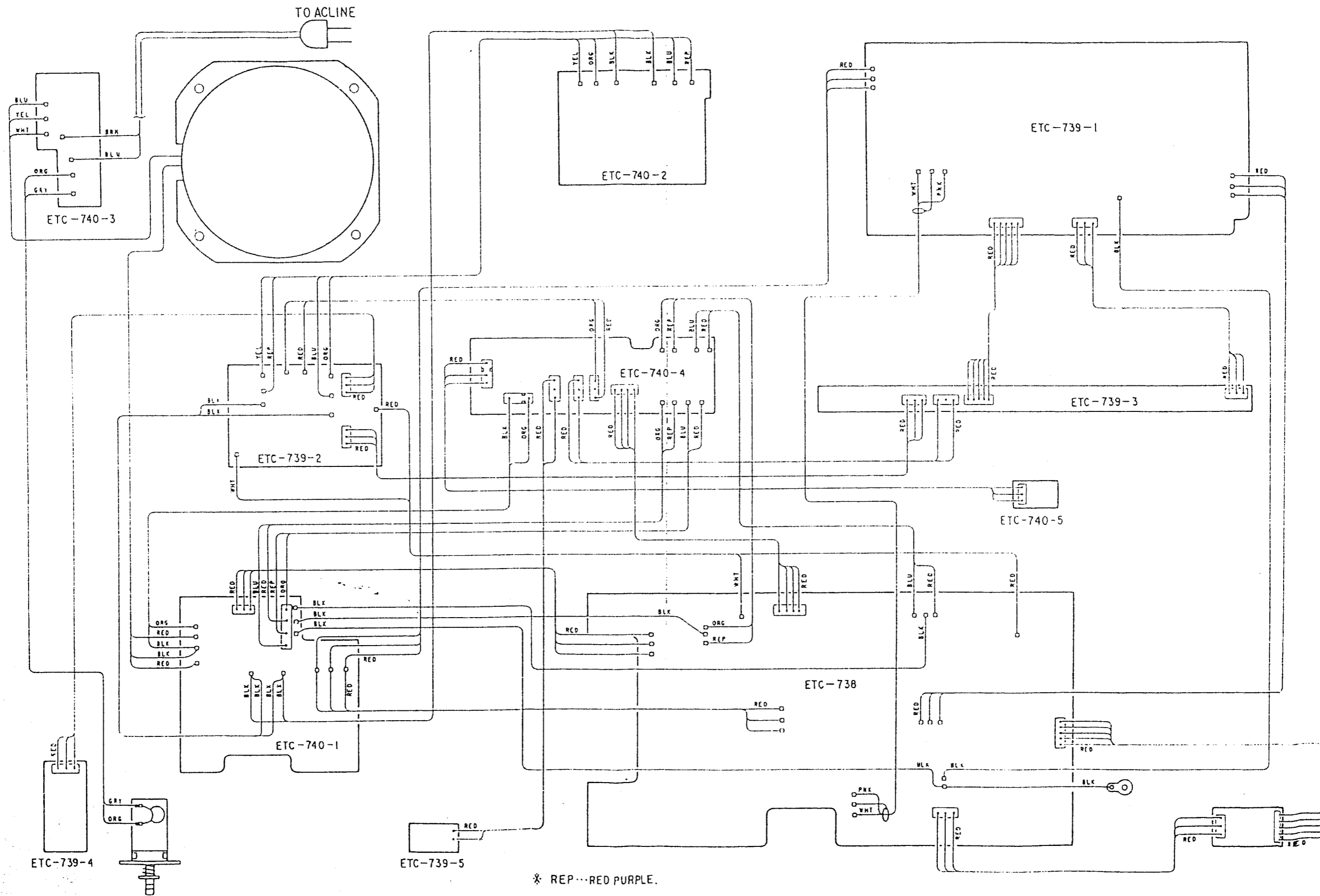

PMA-757  
ETC0740B P.S & PROTECT UNIT

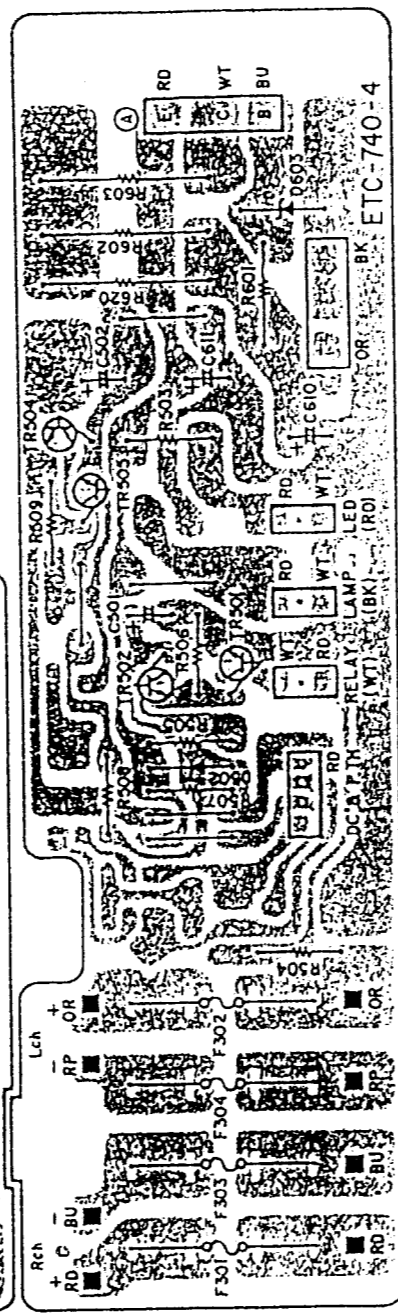
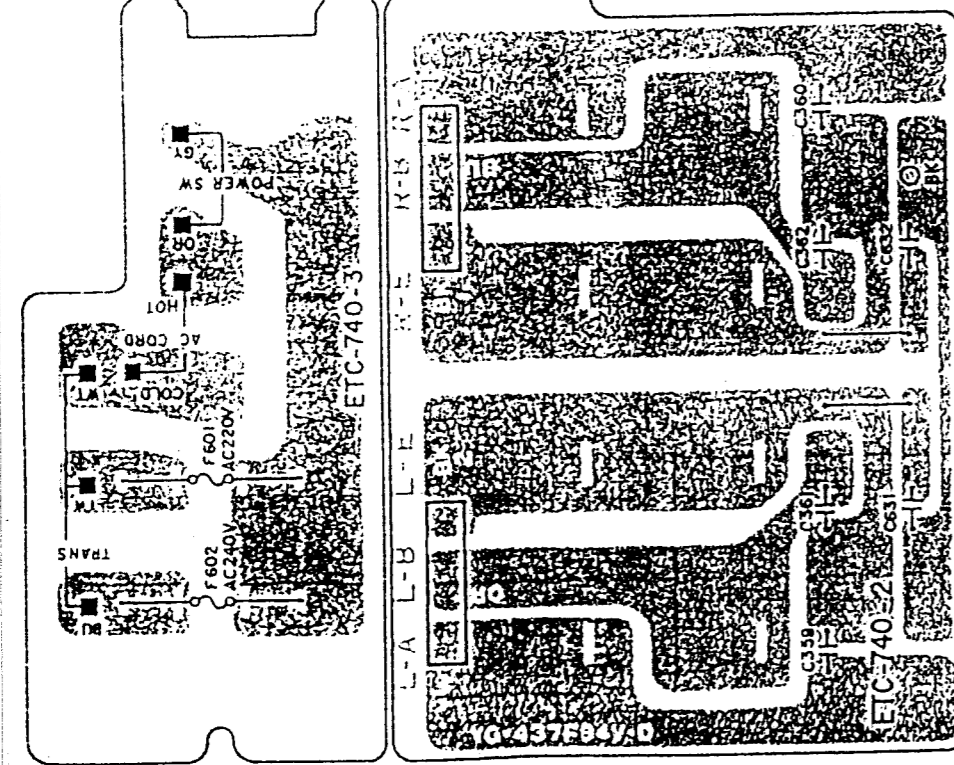
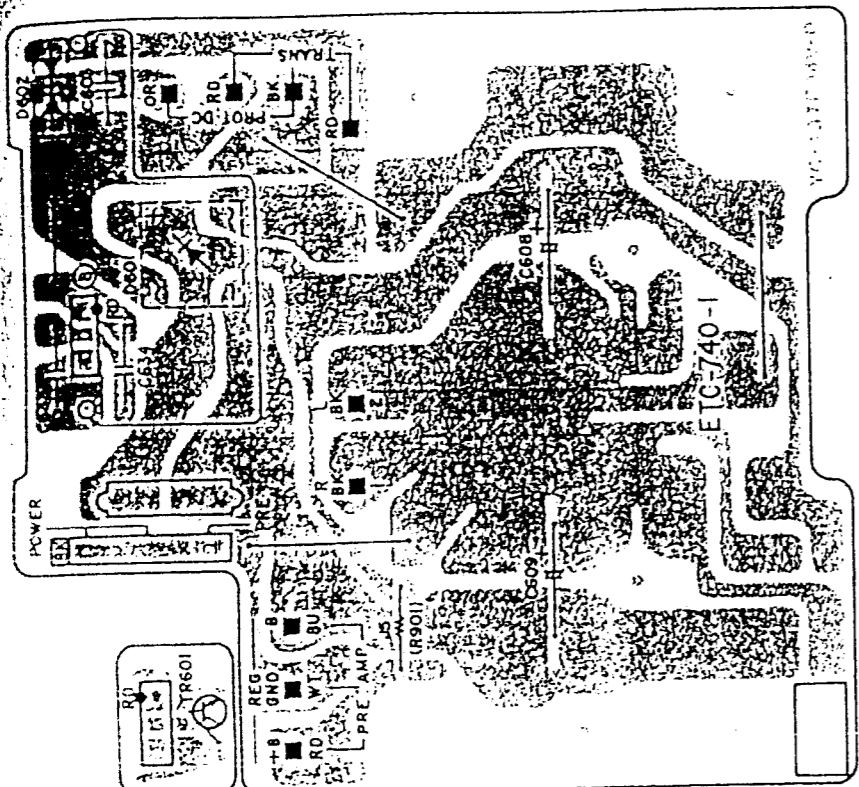

ETC0740B P.S & PROTECT UNIT PARTS LIST

Ref. No.	Part No.	Part Name & Descriptions
SEMICONDUCTORS		
TR501	2730235020	2SC1841(F)/(E) TRANSISTOR
TR502	2730269038	2SC1685(R) TRANSISTOR
TR504, 505	2730269038	2SC1685(R) TRANSISTOR
TR601	2740088018	2SD1406(Y)/(GR) TRANSISTOR
D502	2760049008	1S2076 DIODE
D601	2760356005	D5FB20(4001) DIODE
D602	2760151006	108C-1 DIODE
D603	2760256008	HZ-16-2 ZENER
RESISTORS		
R503	2412096008	1.5k ohm ±5% 1/4W CARBON
TR504	2412369081	330 ohm ±5% 1/4W CARBON (NB)
R505	2412116001	10k ohm ±5% 1/4W CARBON
R506	2412108006	4.7k ohm ±5% 1/4W CARBON
R507	2412164008	1M ohm ±5% 1/4W CARBON
R508	2412036000	4.7 ohm ±5% 1/4W CARBON
R509	2412116001	10k ohm ±5% 1/4W CARBON
R601	2410205008	6.8k ohm ±5% 1/2W CARBON COMPOSIT
TR602	2440086022	100 ohm ±5% 2W METAL OXIDE (NB)
TR603	2440079026	27 ohm ±5% 2W METAL OXIDE (NB)
TR620	2440086022	100 ohm ±5% 2W METAL OXIDE (NB)
CAPACITORS		
C359 ~362	2531025002	0.022µF +80,-20% 50V CERAMIC
C501	2544009002	47µF ±20% 10V ELECTROLYTIC
C502	2544161034	330µF ±20% 6.3V ELECTROLYTIC
C603	2531053003	0.01µF +100,-0% 500V CERAMIC
C608, 609	2546063004	15000µF/15000µF 63V ELECTROLYTIC
C610	2544063035	100µF ±20% 80V ELECTROLYTIC
C611	2544089006	1µF ±20% 50V ELECTROLYTIC
C633, 634	2531053003	0.01µF +100,-10% 500V CERAMIC
C631, 632	2531024003	0.01µF +80,-20% 50V CERAMIC
FUSE		
F301 ~304	2061040036	FUSE (F5A) SEMKO MINI
F601	2061015074	FUSE (T3.15A) SEMKO MINI
OTHER PARTS		
2221092109		P.W. BOARD
EP-5667H1		TERMINAL PIN USED 26
2050008120		JUMPER WIRE P=10mm USED 5
2050185054		5P WIRE HOLDER
2050185038		3P WIRE HOLDER
2050190036		3PIN CONNECTOR BASE USED 3
2050122033		3P CONNECTOR PIN ASS'Y USED 2
2050087039		3P TERMINAL USED 3
2090052008		JUMPER D1.6 L=20mm USED 3
2034163063		3P CONNECTOR CORD
2034193046		3P CONNECTOR CORD
4120952102		CONDENSER BRACKET
2050144008		8P TERMINAL
2050178003		EARTH PLATE
4730354019		TAPPING SCREW (2) 3x8 USED 4
5130934009		FUSE LABEL

Ref. No.	Part No.	Part Name & Descriptions
	2020022008	FUSE HOLDER USED 10
	2030226027	1P CONTACT ASS'Y
(R901)J5	2050008120	JUMPER IWRE P=10mm

ETC0740M E1 for Asia  
(Same as ETC0740B except the followings.)

Ref. No.	Part No.	Part Name & Descriptions
CAPACITORS		
C631, 632	2531024003	0.01µF +80,-20% 50V CERAMIC (DELETE)
C633, 634	2531053003	0.01µF +100,-0% 500V CERAMIC (DELETE)
C359 ~362	2531025002	0.022µF +80,-20% 50V CERAMIC (DELETE)
OTHER PARTS		
	5130934009	FUSE LABEL (DELETE)
	2020022008	FUSE HOLDER USED 8 (CHANGE)
	2061015087	FUSE (4A) (DELETE)
	2030226027	1P CONTACT ASS'Y (DELETE)

ETC0740N E3 for U.S.A., & EC for Canada  
(Same as ETC0740B except the followings.)

Ref. No.	Part No.	Part Name & Descriptions
CAPACITORS		
C633, 634	2531053003	0.01µF +100,-0% 500V CERAMIC (DELETE)
C631, 632	2531024003	0.01µF +80,-20% 50V CERAMIC (DELETE)
C359 ~362	2531025002	0.022µF +80,-20% 50V CERAMIC (DELETE)
OTHER PARTS		
F301 ~304	2061046027	FUSE 5A (UL) (CHANGE)
F601	2061046001	FUSE 6.3A (UL) (CHANGE)
	2030226027	1P CONTACT ASS'Y (DELETE)
(R901)J5	2412321032	4.7 ohm ±5% 1/4W CARBON (NB)
	5130854037	FUSE LABEL (ADD)
	5130854011	FUSE LABEL USED 4 (ADD)

ETC0740P EA for Australia & EK for U.K.  
(Same as ETC0740B except the followings.)

Ref. No.	Part No.	Part Name & Descriptions
CAPACITORS		
C633, 634	2531053003	0.01µF +100,-0% 500V CERAMIC (DELETE)
C631, 632	2531024003	0.01µF +80,-20% 50V CERAMIC (DELETE)
C359 ~362	2531025002	0.022µF +80,-20% 50V CERAMIC (DELETE)
OTHER PARTS		
F601	2030226027	1P CONTACT ASS'Y (DELETE)
F602	2061015087	FUSE (T.4A) MINISEMKO (DELETE)
	2061015087	FUSE (T.4A) MINISEMKO (ADD)

• PMA-757  
ETC0739B INPUT & EQ. UNIT

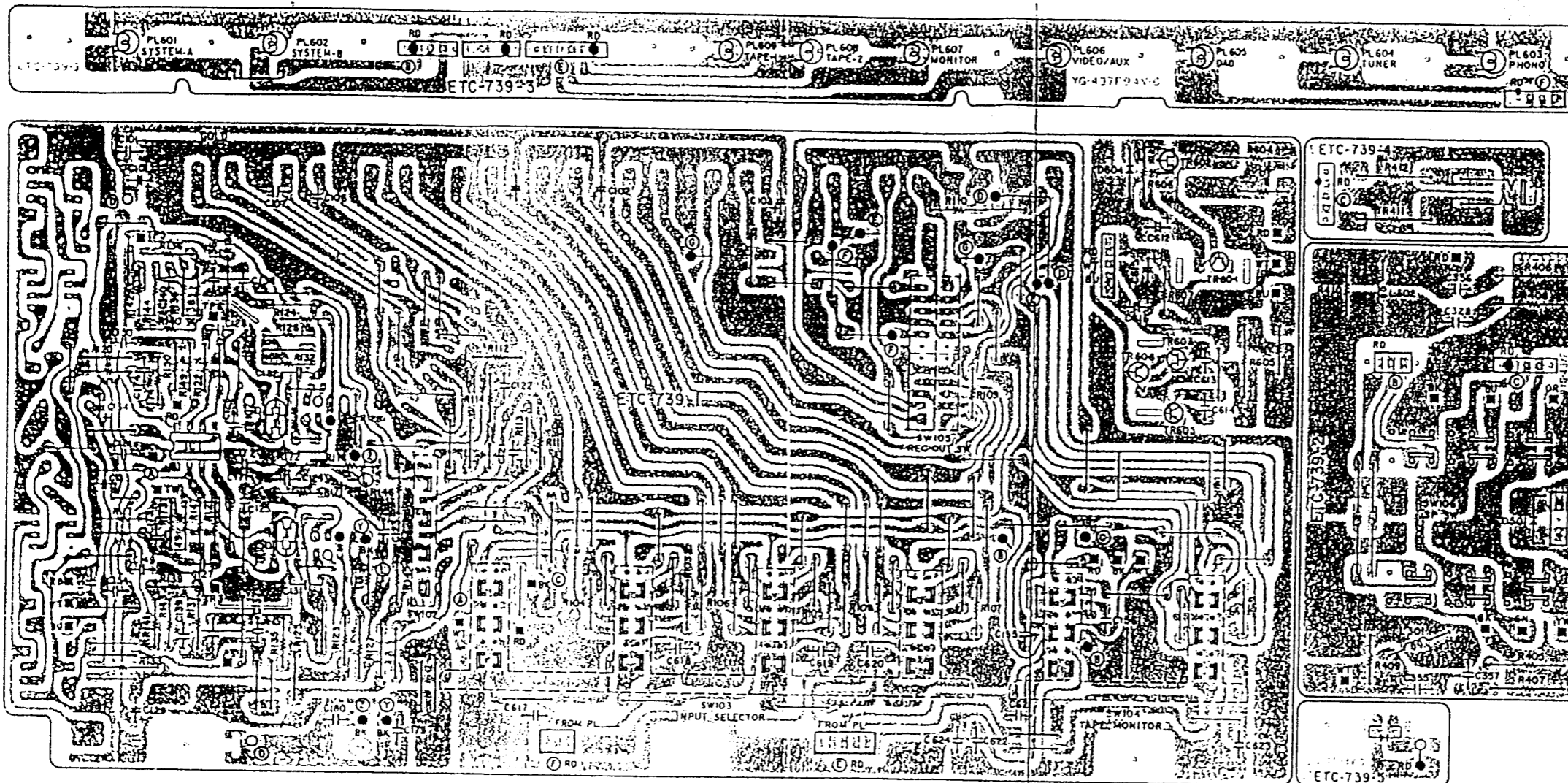

Ref. No.	Part No.	Part Name & Descriptions
C357, 358	2551121067	0.022μF ±5% 50V PLASTIC FILM
C612	2544153000	47μF ±20% 50V ELECTROLYTIC
C615, 616	2544146004	1μF ±20% 50V ELECTROLYTIC
C617 ~624	2531024003	0.01μF +80,-20% 50V CERAMIC
SWITCHES		
SW102	2124330007	SLIDE SW (4-2) REMOTE CARTRIDGE
SW103	2124512003	4P PUSH SW INPUT SEL.
SW104	2124422009	2P PUSH SW TAPE MONITOR
SW105	2124187001	SLIDE SW (4-4) REMOTE
SW106	2124510005	2P PUSH SW REC OUT SEL S.P.
OTHER PARTS		
	2221091100	P.W. BOARD
	EP-5667H1	TERMINAL PIN USED 30
	2090008146	JUMPER WIRE P=5mm USED 5
	2090008133	JUMPER WIRE P=7.5mm USED 2
	2090008120	JUMPER WIRE P=10mm USED 100
	2090008117	JUMPER WIRE P=12.5mm USED 10
LE501	3939154008	PR5552K-1 (RED) LED
L301, 302	2350007007	INDUCTOR
PL601 ~609	3930083000	PILOT LAMP 16V 0.04A USED 9
	4530022208	LAMP COVER (A) USED 7
	4530023207	LAMP COVER (B) USED 1
	1220109007	BLIND SHEET
	4410412200	LED HOLDER
	2034197097	3P CONNECTOR CORD
	2034214019	3P CONNECTOR CORD
	2034185096	3P CONNECTOR CORD
	2034181074	3P CONNECTOR CORD
	2034181087	3P CONNECTOR CORD
	2038132016	5P CONNECTOR CORD
RL501	2140037009	RELAY
	2048100009	HEADPHONE JACK
	2036084001	4P CONNECTOR BASE
	2040079002	6P CONNECTOR BASE USED 2
	4140240001	EARTH PLATE
	2048059008	DIN JACK (5P)
	4170043100	RADIATOR USED 2
	4730354019	TAPPING SCREW (2) 3x8 USED 2
	2050190036	3P NH CONNECTOR BASE USE O 2
	2050190052	5P NH CONNECTOR BASE
	2050185038	3P WIRE HOLDER USED 7
	2050185054	5P WIRE HOLDER
	2030225073	1P CONTACT ASS'Y

ETC0739B INPUT & EQ. UNIT PARTS LIST

Ref. No.	Part No.	Part Name & Descriptions
SEMICONDUCTORS		
IC101	2630081015	NJM4558DX (JRC) IC
TR101, 102	2750029025	2SK240(BL)/(V) FET
TR602, 603	2750043001	2SK381(BI)/(C) FET
TR604	2730236029	2SC2824(Y/O) TRANSISTOR
TR605	2710178039	2SA564A(R) TRANSISTOR
TR606	2710135027	2SA1184(Y/O) TRANSISTOR
D501	2760191008	W03C DIODE
D604	2760301005	HZ22-2 ZENER
RESISTORS		
R129, 130	2420203003	10M ohm ±10% 1/4W CARBON COMPOSIT

Ref. No.	Part No.	Part Name & Descriptions
AR133	2412321003	4k ohm ±5% 1/4W CARBON (NB)
AR405, 408	2440021029	22 ohm ±5% 1W METAL OXIDE (NB)
AR411, 412	2440030023	120 ohm ±5% 1W METAL OXIDE (NB)
AR604, 605	2440038027	390 ohm ±5% 1W METAL OXIDE (NB)
VR101, 102	EP-5462H1	SOLID VR 100 ohm
CAPACITORS		
C101, 103	2544145005	0.47μF ±20% 50V ELECTROLYTIC
C121, 122	2531024003	0.01μF +80,-20% 50V CERAMIC
C127, 128	2551121009	0.0068μF ±5% 50V PLASTIC FILM
C129	2544164031	220μF ±20% 25V ELECTROLYTIC

Ref. No.	Part No.	Part Name & Descriptions
C131, 132	2541010007	10μF ±20% 10V TANTALUM
C133, 134	2544146004	1μF ±20% 50V ELECTROLYTIC
C135, 136	2551121041	0.015μF ±5% 50V PLASTIC FILM
C137, 138	2551120000	0.001μF ±5% 50V PLASTIC FILM
C139, 140	2551122011	0.056μF ±5% 50V PLASTIC FILM
C149, 150	2551120097	0.0056μF ±5% 50V PLASTIC FILM
C153, 154	2531024003	0.01μF +80,-20% 50V CERAMIC
C181	2531024003	0.01μF +80,-20% 50V CERAMIC
C355, 356	2551121025	0.01μF ±5% 50V PLASTIC FILM

ETC0739N E3 for U.S.A., and EC for Canada  
(Same as ETC0739B except the followings.)

Ref. No.	Part No.	Part Name & Descriptions
RESISTORS		
R109, 110	2412156003	470k ohm ±5% 1/4W CARBON (DELETE)
R171, 172	2090008120	JUMPER WIRE P=10mm (CHANGE)
R121, 122	2412090004	820 ohm ±5% 1/4W CARBON (DELETE)
R149, 150	2412068007	100 ohm ±5% 1/4W CARBON (DELETE)

• PMA-757  
ETC0738B TONE & POWER UNIT PARTS LIST

Ref. No.	Part No.	Part Name & Descriptions
SEMICONDUCTORS		
TR221, 222	2750046008	2SK170(BL)/(V)DVGS FET
IC301	2630257001	M-5218P (MITSUBISHI) IC
TR201, 202	2750046008	2SK170(BL)/(V)DVGS FET
TR203, 206	2730235020	2SC1841(E/F) TRANSISTOR
TR207, 210	2710131021	2SA988(E/F) TRANSISTOR
TR211, 212	2730235020	2SC1841(E/F) TRANSISTOR
TR213, 214	2730307000	2SC2229(O)/(Y) TRANSISTOR
TR215, 216	2710185006	2SA949(O)/(Y) TRANSISTOR
TR301, 302	2730198015	2SC1815(BL) TRANSISTOR
TR303, 304	2730307000	2SC2229(O)/(Y) TRANSISTOR
TR305, 306	2710185006	2SA949(O)/(Y) TRANSISTOR
TR307, 308	2730226042	2SC2275(O)/(P) TRANSISTOR
TR309, 310	2710123042	2SA985(O)/(P) TRANSISTOR
D205, 210	2760049008	1S2076 DIODE
D301, 304	2760253001	HZ15-2 ZENER
D305, 308	2760049008	1S2076 DIODE
D309, 310	2760388002	MV-1YH DIODE
D311, 312	2760236031	HZ5C-1 ZENER
D317, 336	2760049008	1S2076 DIODE
RESISTORS (not included Carbon ±5%, 1/4W Type)		
R209, 210	2420203003	10M ohm ±10% 1/4W CARBON COMPOSIT
R211, 212	2412214023	470 ohm ±5% 1/4W CARBON (NB)
R223, 225	2412214023	470 ohm ±5% 1/4W CARBON (NB)
R231, 232	2412216047	250 ohm ±5% 1/4W CARBON (FB)
R233, 234	2412218053	10 ohm ±5% 1/4W CARBON (FB)
R235, 236	2410055021	100 ohm ±5% 1W METAL OXIDE (NB)
R237, 238	2412218053	10 ohm ±5% 1/4W CARBON (FB)
R239, 240	2412214007	100 ohm ±5% 1/4W CARBON (NB)
R390, 391, 395, 396	2090008120	JUMPER WIRE P=10mm

Ref. No.	Part No.	Part Name & Descriptions
R301, 304	2410103028	27k ohm ±5% 3W METAL OXIDE (NB)
R305, 306	2412214045	220 ohm ±5% 1/4W CARBON (NB)
R309, 310	2412216003	10 ohm ±5% 1/4W CARBON (NB)
R345, 348	2412218053	10 ohm ±5% 1/4W CARBON (FB)
R349, 350	2412214003	10 ohm ±5% 1/4W CARBON (NB)
R351, 354	2412218003	100 ohm ±5% 1/4W CARBON (FB)
R359, 360	2410029021	100 ohm ±5% 1W METAL OXIDE (NB)
R363, 366	2412214032	47 ohm ±5% 1/4W CARBON (NB)
R385, 388	2412218003	100 ohm ±5% 1/4W CARBON (FB)
R421, 422	2412214007	100 ohm ±5% 1/4W CARBON (NB)
VR201	2110424008	VARIABLE RESISTOR 100k ohm MAIN
VR202	2110198004	VARIABLE RESISTOR 250k ohm BALANCE
VR203	2110309107	VARIABLE RESISTOR 50k ohm TREBLE
VR204	2110309110	VARIABLE RESISTOR 100k ohm BASS
VR301, 302	2116025087	SEMI-FIXED RESISTOR 4.7k ohm IDLE
VR303, 304	2116025016	SEMI-FIXED RESISTOR 100 ohm DISTORTION
CAPACITORS (not included Ceramic ±5%, ±10%, 50V Type)		
C201, 202	2551122040	0.1μF ±5% 50V PLASTIC FILM
C203, 204	2551122037	0.082μF ±5% 50V PLASTIC FILM
C207, 208	2551120000	0.001μF ±5% 50V PLASTIC FILM
C209, 210	2551120084	0.0047μF ±5% 50V PLASTIC FILM
C213, 214	2544146004	1μF ±20% 50V ELECTROLYTIC
C215, 216	2554079048	0.01μF ±5% 100V PLASTIC FILM
C217, 218	2534269001	10pF ±0.5pF 500V CERAMIC
C219, 220	2544181001	1μF ±20% 100V ELECTROLYTIC
C223, 224	2551121009	0.0068μF ±5% 50V PLASTIC FILM
C225, 226	2551122011	0.056μF ±5% 50V PLASTIC FILM
C229, 230	2551120013	0.0012μF ±5% 50V PLASTIC FILM
C231, 232	2551121096	0.039μF ±5% 50V PLASTIC FILM
C233, 234	2551122095	0.27μF ±5% 50V PLASTIC FILM
C239, 240	2543016067	10μF ±20% 50V ELECTROLYTIC (B. POLE)
C241, 242	2544181001	1μF ±20% 100V ELECTROLYTIC
C243, 244	2544181001	1μF ±20% 100V ELECTROLYTIC
C301, 304	2544089002	100μF ±20% 50V ELECTROLYTIC

Ref. No.	Part No.	Part Name & Descriptions
CAPACITORS		
C106, 107	2533639001	330pF ±5% 50V CERAMIC (DELETE)
C121, 122	2531024003	0.01μF +80,-20% 50V CERAMIC (DELETE)
C125, 126	2533645008	560pF ±5% 50V CERAMIC (DELETE)
C127, 128	2551120084	0.0047μF ±5% 50V PLASTIC FILM (CHANGE)
C155, 156	2533643000	470pF ±5% 50V CERAMIC (DELETE)
C171, 172	2533636004	240pF ±5% 50V CERAMIC (DELETE)
C173, 174	2533627000	100pF ±5% 50V CERAMIC (DELETE)
C175, 176	2533629008	120pF ±5% 50V CERAMIC (DELETE)
C176, 177	2533631009	150pF ±5% 50V CERAMIC (DELETE)
C177	2531054031	0.0012μF ±10% 50V CERAMIC (DELETE)
OTHER PARTS		
	2030225073	1P CONTACT ASS'Y (DELETE)
	2048059008	DIN JACK (5P) (DELETE)
	2090008120	JUMPER WIRE P=10mm USED 102 (CHANGE)

ETC0739M E1 for Asia  
(Same as ETC0739B except the followings.)

Ref. No.	Part No.	Part Name & Descriptions
RESISTORS		
R109, 110	2412156003	470k ohm ±5% 1/4W CARBON (DELETE)
R121, 122	2412090004	820 ohm ±5% 1/4W CARBON (CHANGE)
R149, 150	2412068007	100 ohm ±5% 1/4W CARBON (CHANGE)
R171, 172	2090008120	JUMPER WIRE P=10mm (CHANGE)
CAPACITORS		
C106, 107	2533639001	330pF ±5% 50V CERAMIC (DELETE)
C155, 156	2533643000	470pF ±5% 50V CERAMIC (DELETE)
C125, 126	2533645008	560pF ±5% 50V CERAMIC (DELETE)
C127, 128	2551120084	0.0047μF ±5% 50V PLASTIC FILM (CHANGE)
C121, 122	2531024003	0.01μF +80,-20% 50V CERAMIC (DELETE)
C177	2531054031	0.0012μF ±10% 50V CERAMIC (DELETE)
C171, 172	2533636004	240pF ±5% 50V CERAMIC (DELETE)
C173, 174	2533627000	100pF ±5% 50V CERAMIC (DELETE)
C176	2533631009	150pF ±5% 50V CERAMIC (DELETE)
C175	2533629008	120pF ±5% 50V CERAMIC (DELETE)
OTHER PARTS		
	2030225073	1P CONTACT ASS'Y (DELETE)
	2090008120	JUMPER WIRE P=10mm USED 102 (CHANGE)

Ref. No.	Part No.	Part Name & Descriptions
C175	2533629008	120pF ±5% 50V CERAMIC (DELETE)
C176	2533631009	150pF ±5% 50V CERAMIC (DELETE)
OTHER PARTS		
	2030225073	1P CONTACT ASS'Y (DELETE)
	2048059008	DIN JACK (5P) (DELETE)
	2090008120	JUMPER WIRE USED 102 (CHANGE)

ETC0739P EA for Australia and EK for U.K.  
(Same as ETC0739B except the followings.)

Ref. No.	Part No.	Part Name & Descriptions
RESISTORS		
R121, 122	2412090004	820 ohm ±5% 1/4W CARBON (CHANGE)
R149, 150	2412068007	100 ohm ±5% 1/4W CARBON (CHANGE)
R171, 172	2090008120	JUMPER WIRE P=10mm (CHANGE)
CAPACITORS		
C106, 107	2533639001	330pF ±5% 50V CERAMIC (DELETE)
C155, 156	2533643000	470pF ±5% 50V CERAMIC (DELETE)
C125, 126	2533645008	560pF ±5% 50V CERAMIC (DELETE)
C127, 128	2551120084	0.0047μF ±5% 50V PLASTIC FILM (CHANGE)
C121, 122	2531024003	0.01μF +80,-20% 50V CERAMIC (DELETE)
C177	2531054031	0.0012μF ±10% 50V CERAMIC (DELETE)
C171, 172	2533636004	240pF ±5% 50V CERAMIC (DELETE)
C173, 174	2533627000	100pF ±5% 50V CERAMIC (DELETE)
C176	2533631009	150pF ±5% 50V CERAMIC (DELETE)
C175	2533629008	120pF ±5% 50V CERAMIC (DELETE)
OTHER PARTS		
	2030225073	1P CONTACT ASS'Y (DELETE)
	2090008120	JUMPER WIRE P=10mm USED 102 (CHANGE)

ETC0738B TONE & POWER UNIT

NOTE: "\*" parts not used for E2 model.

Ref. No.	Part No.	Part Name & Descriptions
11	2544146004	1μF ±20% 50V ELECTROLYTIC
26	2551120026	0.0015μF ±5% 50V PLASTIC FILM
30	2534482008	33pF ±5% 500V CERAMIC
34	2551121025	0.01μF ±5% 50V PLASTIC FILM
42	2561030070	0.1μF ±5% 100V PLASTIC FILM

SWITCHES

W201	2120221000	ROTARY SWITCH	MODE
W202	2124511004	2P PUSH SWITCH	LOUD, SUB
W203	2124462001	1P PUSH SWITCH	DIRECT

OTHER PARTS

2221090101	P.W. BOARD
EP-5667H1	TERMINAL PIN USED 40
2090008120	JUMPER WIRE P-10mm USED 50
2030230039	1P CONNECTOR
2050185038	3P WIRE HOLDER USED 6
2050185041	4P WIRE HOLDER
2050185054	5P WIRE HOLDER USED 2
4711303018	3x6 CPS USED 2
4756006008	3N USED 2

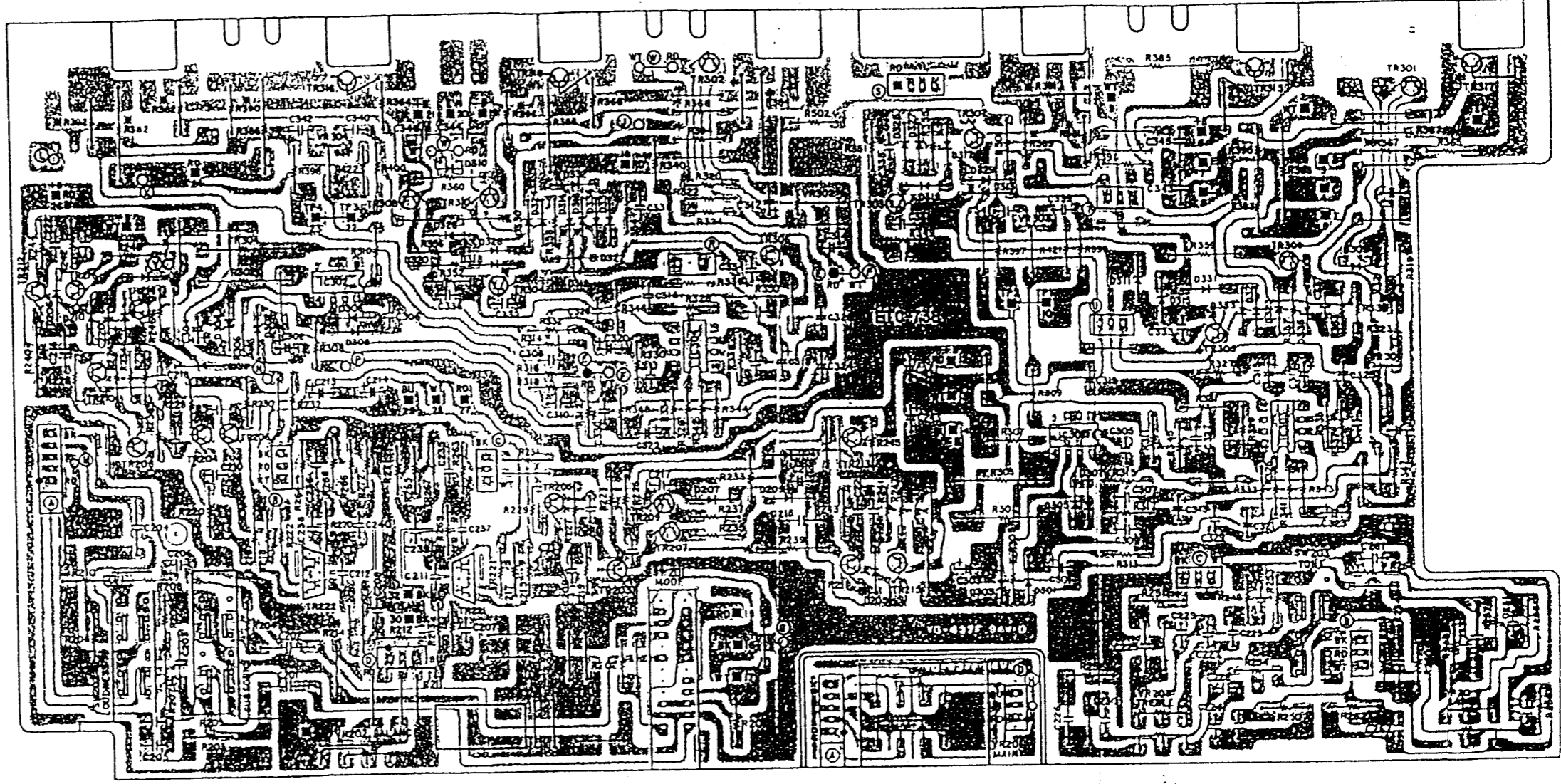

ETC0738M E1 for Asia  
(Same as ETC0738B except the followings.)

Ref. No.	Part No.	Part Name & Descriptions
SEMICONDUCTORS		
D313 ~316	2760236031	HZ5C-1 ZENER (ADD)
RESISTORS		
R219, 220	2412065000	75 ohm ±5% 1/4W CARBON (CHANGE)
R361 362 367	2412321032	47 ohm ±5% 1/4W CARBON (NB) (ADD)
R381 384 388 390	2412025003	22 ohm ±5% 1/4W METAL (NB) (ADD)
R381 384 388 390	2412210106	22 ohm ±5% 1/4W CARBON (NB) (ADD)

ETC0738N E3 for U.S.A., and EC for Canada  
(Same as ETC0738B except the followings.)

Ref. No.	Part No.	Part Name & Descriptions
SEMICONDUCTORS		
D313 ~316	2760236031	HZ5C-1 ZENER (ADD)
RESISTORS		
R219, 220	2412065000	75 ohm ±5% 1/4W CARBON (CHANGE)
R361 362 367	2412321032	47 ohm ±5% 1/4W CARBON (NB) (ADD)
R381 384 388 390	2412025003	22 ohm ±5% 1/4W METAL (NB) (ADD)
R381 384 388 390	2412210106	22 ohm ±5% 1/4W CARBON (NB) (ADD)
CAPACITORS		
C241, 243	2544203002	1μF ±20% 160V ELECTROLYTIC (CHANGE)

ETC0738P EA for Australia and EK for U.K.  
(Same as ETC0738B except the followings.)

Ref. No.	Part No.	Part Name & Descriptions
SEMICONDUCTORS		
D313 ~316	2760236031	HZ5C-1 ZENER (ADD)
RESISTORS		
R219, 220	2412065000	75 ohm ±5% 1/4W CARBON (CHANGE)
R361 362 367	2412321032	47 ohm ±5% 1/4W CARBON (NB) (ADD)
R381 384 388 390	2412025003	22 ohm ±5% 1/4W METAL (NB) (ADD)
R381 384 388 390	2412210106	22 ohm ±5% 1/4W CARBON (NB) (ADD)

CONNECTION DIAGRAM

• PMA-757

This figure is E2 version

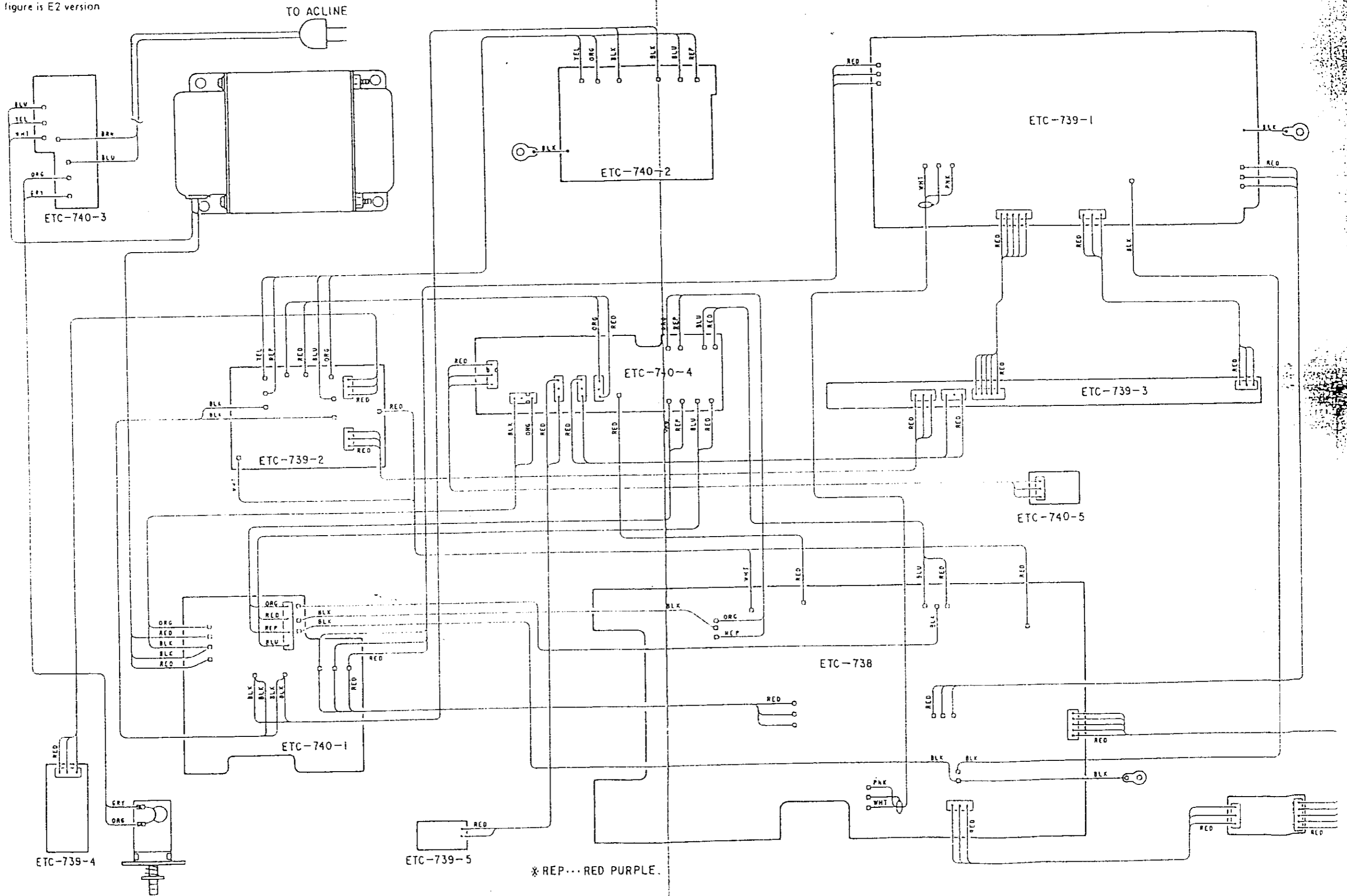

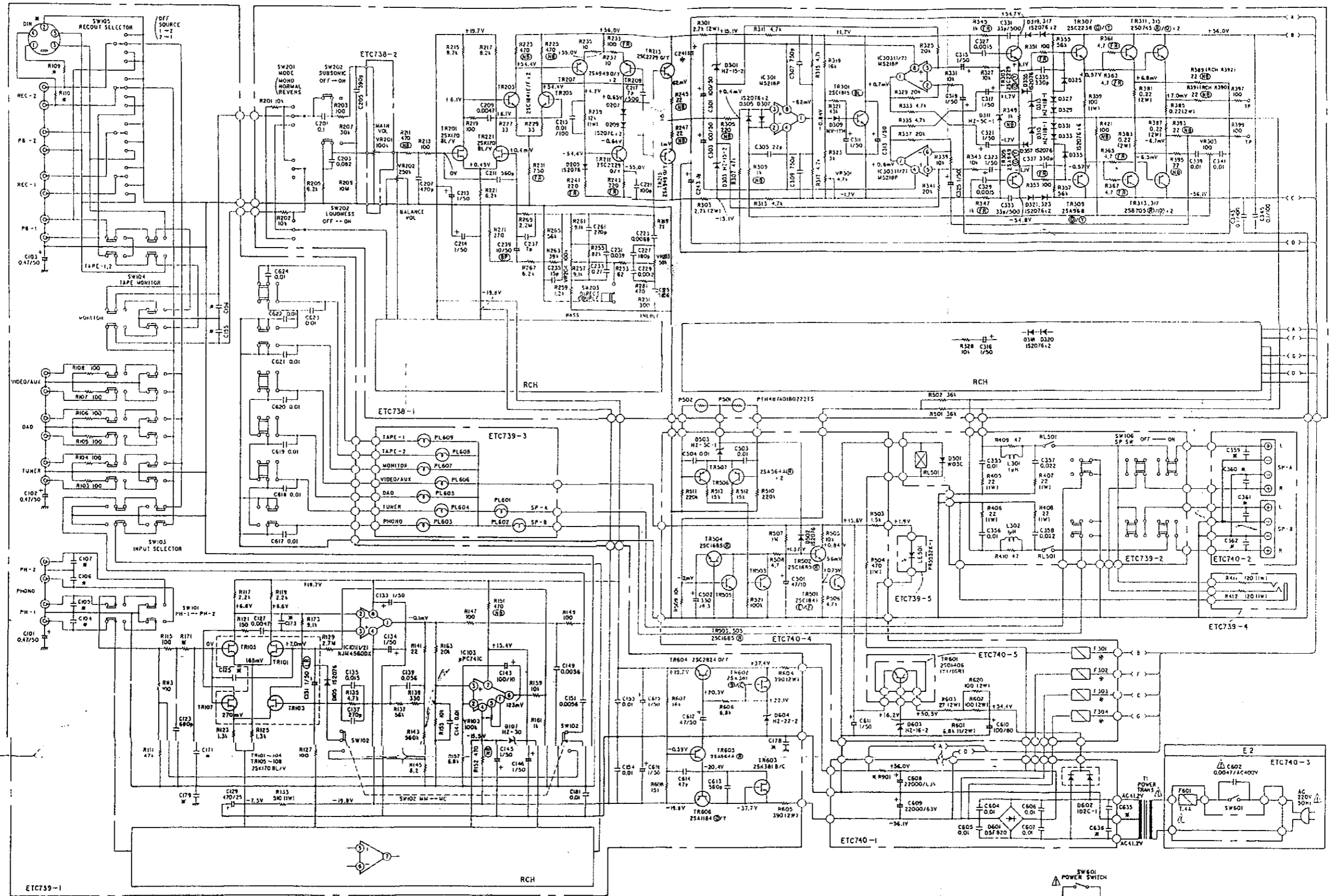

	ETC-739							ETC-738				ETC-740			
	D1R	R109	C133	C104	C173	C123	C178	R171	C171	C241	C243	C359	C634	R901	F301
E2	INCLUDE	R101	470P	430P	47P	560P	0.01	4.7	240P			0.01	0.17	JUMPER	F8.3A
E3 (EH)	-	-	-	-	-	-	-	-	-	F1A0	F1000	-	-	4.7 (JUMPER)	6.3A (F6.3A)
E4, EA	INCLUDE	470P	-	-	-	-	-	-	-	F1A0	F1000	-	-	JUMPER	F6.3A

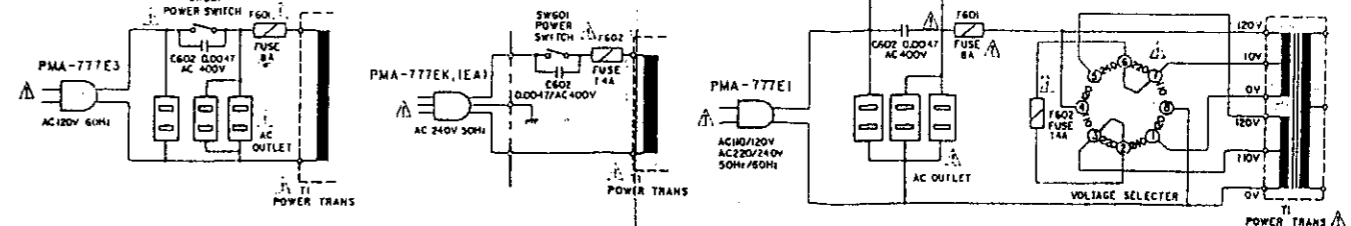

NOTES  
ALL RESISTANCE VALUES IN OHM K = 1,000 OHM M = 1,000,000 OHM

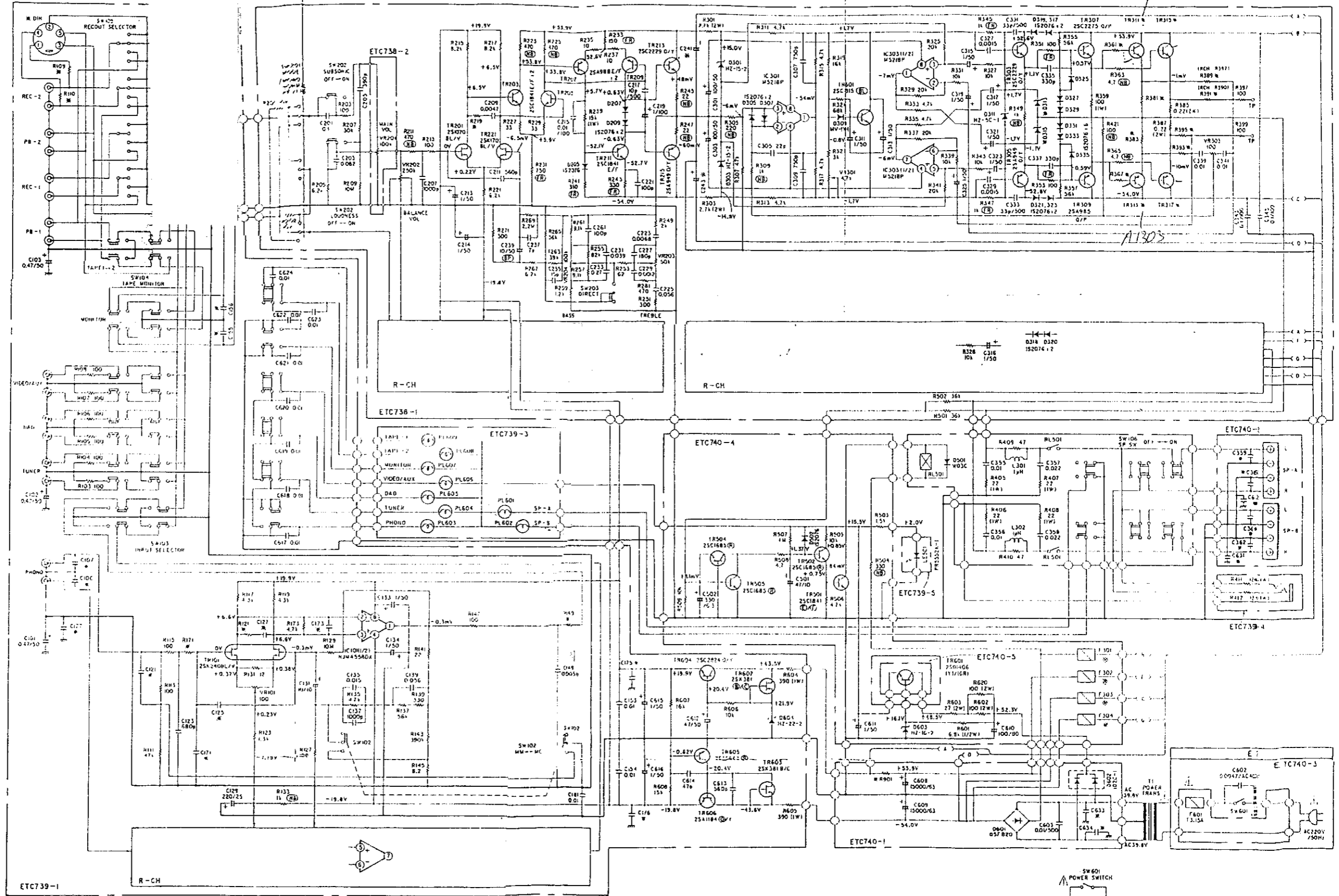

	ETC-739													ETC-738											ETC-740																												
	D17	D18	D19	D20	D21	D22	D23	D24	D25	D26	D27	D28	D29	D30	D31	D32	D33	D34	D35	D36	D37	D38	D39	D40	D41	D42	D43	D44	D45	D46	D47	D48	D49	D50	D51	D52	D53	D54	D55	D56	D57	D58	D59	D60									
ET-EC	...	...	...	...	...	...	...	...	...	...	...	...	...	...	...	...	...	...	...	...	...	...	...	...	...	...	...	...	...	...	...	...	...	...	...	...	...	...	...	...	...	...	...	...	...	...	...	...	...	...			
ET-FA	...	...	...	...	...	...	...	...	...	...	...	...	...	...	...	...	...	...	...	...	...	...	...	...	...	...	...	...	...	...	...	...	...	...	...	...	...	...	...	...	...	...	...	...	...	...	...	...	...	...	...	...	...
ET-LA	...	...	...	...	...	...	...	...	...	...	...	...	...	...	...	...	...	...	...	...	...	...	...	...	...	...	...	...	...	...	...	...	...	...	...	...	...	...	...	...	...	...	...	...	...	...	...	...	...	...	...	...	

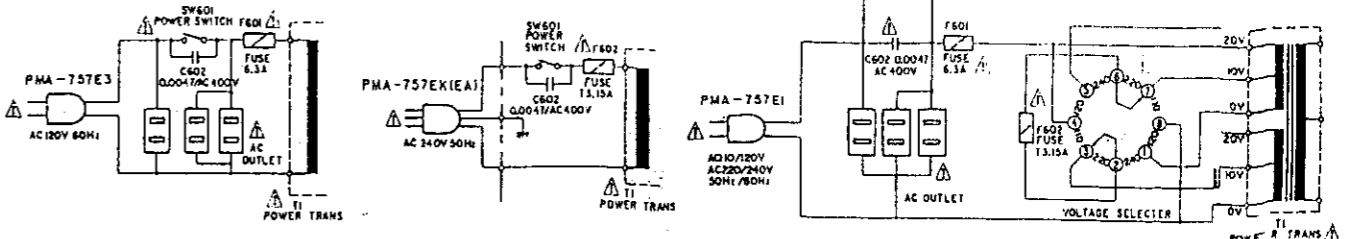

NOTES:  
ALL RESISTANCE VALUES IN OHM, K = 1,000 OHM, M = 1,000,000 OHM  
ALL CAPACITANCE VALUES IN MICROFARAD, P = MICRO-MICRO FARAD  
EVERY VOLTAGES AND CURRENTS IS MEASURED AT NO SIGNAL INPUT CONDITION.  
CIRCUIT AND PARTS ARE SUBJECT TO CHANGE WITHOUT PRIOR NOTICE



EXPLODED VIEW OF CHASSIS AND CABINET  
• PMA-777

⚠ Means important safety item, which must be followed when necessary, by a part specified or meeting the requirements by the manufacturer.

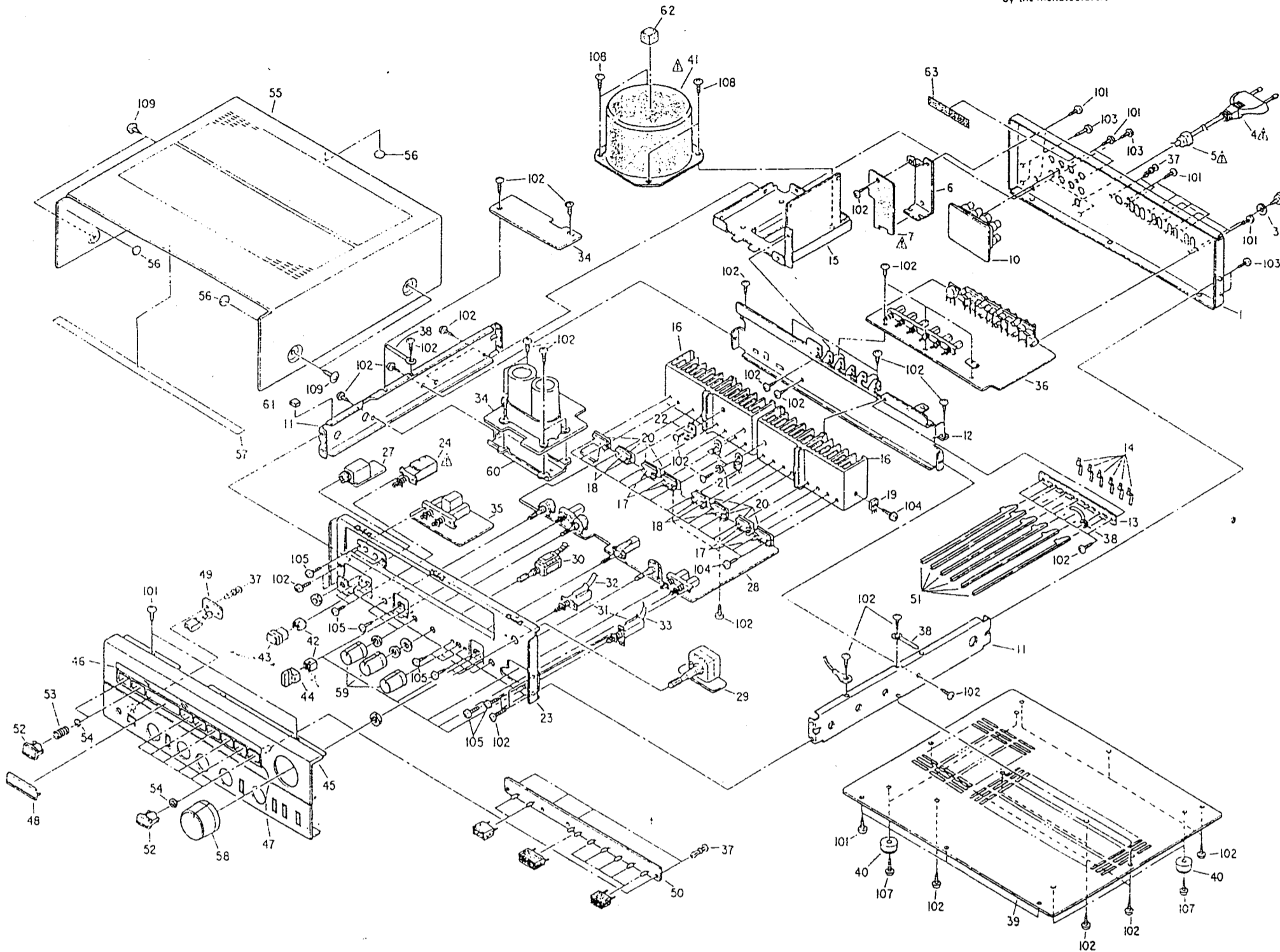

Note: 1. See asterisk list below for the parts with asterisk (\*) on the Ref. No. and the other parts not included in this list.  
2. The list is prepared based on E2 Silver Version  
3. \* Marked not included EXPLODED VIEW.  
4. ° Marked same as PMA-757E2.

EXPLODED VIEW OF PARTS LIST

Ref. No.	Part No.	Part Name & Descriptions
* 1	1050626307	BACK PANEL
• 2	2050071016	TERMINAL ASS'Y
• 3	4770018001	WASHER (P-87)
• 6	4410455005	PWB BRACKET
• 8	5130716022	FTZ LABEL
• 9	5138253009	APPROVAL MARK
* 10	ETC0740-2	SP TERMINAL UNIT
• 11	4120733606	SIDE CHASSIS
• 12	4110375317	MAIN CHASSIS
• 13	4410378108	SHEET
• 14	4630373000	SPRING
• 15	4110334206	TRANS CHASSIS ASS'Y
• 16	4170153401	POWER RADIATOR
• 17	2740102004	TRANSISTOR 2SD745(R/C)
• 18	2720073001	TRANSISTOR 2SB705(R/O)
• 19	2740088018	TRANSISTOR 2SD1406(Y)/(GR)
• 20	4150291008	INSULATING SHEET (S-27)
• 21	2760289004	POSISTOR (PTH487A018D222TS)
• 22	4410411104	PCB BRACKET
• 23	4110429302	FRONT CHASSIS
• 24	4120630278	PUSH SWITCH (FOR P/SW) WITH WASHERS
• 25	4120630134	CAPACITOR (4000PF 400VAC)
• 26	4450033005	WIRE CLAMP BAND USED 36
• 27	ETC0739-4	HEADPHONE JACK UNIT
• 28	ETC0738-1	TONE & POWER UNIT

Ref. No.	Part No.	Part Name & Descriptions
* 29	ETC0738-2	MAIN VR UNIT
• 30	2120222009	ROTARY REMOTE
• 31	2124484005	1P-PUSH REMOTE
• 32	4350052005	FLEXIBLE SLIDER (IMM-MC)
• 33	4350052021	FLEXIBLE SLIDER (PHONO 1-2)
* 34	ETC0740	P.S & PROT. UNIT
* 35	ETC0739-2	SPEAKER SW UNIT
* 36	ETC0739-1	INPUT & EQ. UNIT
• 37	4770096007	PUSH RIVET
• 38	EP-6214	CORD HOLDER
• 39	1050450609	BOTTOM COVER
• 40	1040110001	FOOT
* 41	2336488007	POWER TRANSFORMER
• 42	1140056007	FLEXIBLE RING
* 43	1130515134	PUSH KNOB (A)
* 44	1130450118	PUSH KNOB (B) ASS'Y
* 45	1441257000	FRONT PANEL ASS'Y
• 46	1430297013	WINDOW
• 47	1460556106	WINDOW PANEL
* 48	1441256001	ESC. PLATE
* 49	ETC0739-5	LED UNIT
* 50	ETC0739-3	LAMP UNIT
* 51	4121009007	CONNECTING BRACKET
* 52	1130415218	PUSH KNOB (C)
• 53	4630274011	SPRING
• 54	1220039012	SPACER
* 55	1020183100	TOP COVER

Ref. No.	Part No.	Part Name & Descriptions
• 56	1040034006	STOPPER
• 57	1220069008	SPACER
• 58	1120415011	KNOB (A)
• 59	1120416010	KNOB (B)
• 60	4120952102	CONDENSER BRACKET
• 61	4610223024	RUBBER SHEET
• 62	4610223011	RUBBER SHEET
• 63	1220069066	SPACER
• 64		
• 65		
• 66		
• 67		
• 68		
• 69		
• 70		
PACKING & ACCESSORIES (not included EXPLODED VIEW)		
• a.	5040084007	SET COVER
• b.	5030456001	CUSHION
• c.	5111253107	INST. MANUAL
• d.	5139111001	COLOR LABEL (GOLD)
• e.	5130795009	CONTROL CARD
• f.	5010916037	CAUTION CASE

Ref. No.	Part No.	Part Name & Descriptions	Qty.
SCREWS & NUT			
• 101	4730354035	TAPPING SCREW (2) 3x8 (BLACK)	22
• 102	4730354019	TAPPING SCREW (2) 3x8	33
• 103	4770064107	FIXING SCREW	6
• 104	4700011023	PAN SCREW WITH W. SPW 3x10	17
• 105	4711303018	PAN SCREW 3x6	13
• 107	4730804035	TAPPING SCREW (2) 3x14	4
• 108	4700031016	TAPPING SCREW WITH TWB 4x10	4
• 109	4734801005	TAPPING SCREW (TRUS) 4x8	4
• 110			
• 111			
• 112			

⚠ Means important safety item, which must be replaced, when necessary, by a part specified or meeting the specification by the manufacturer.

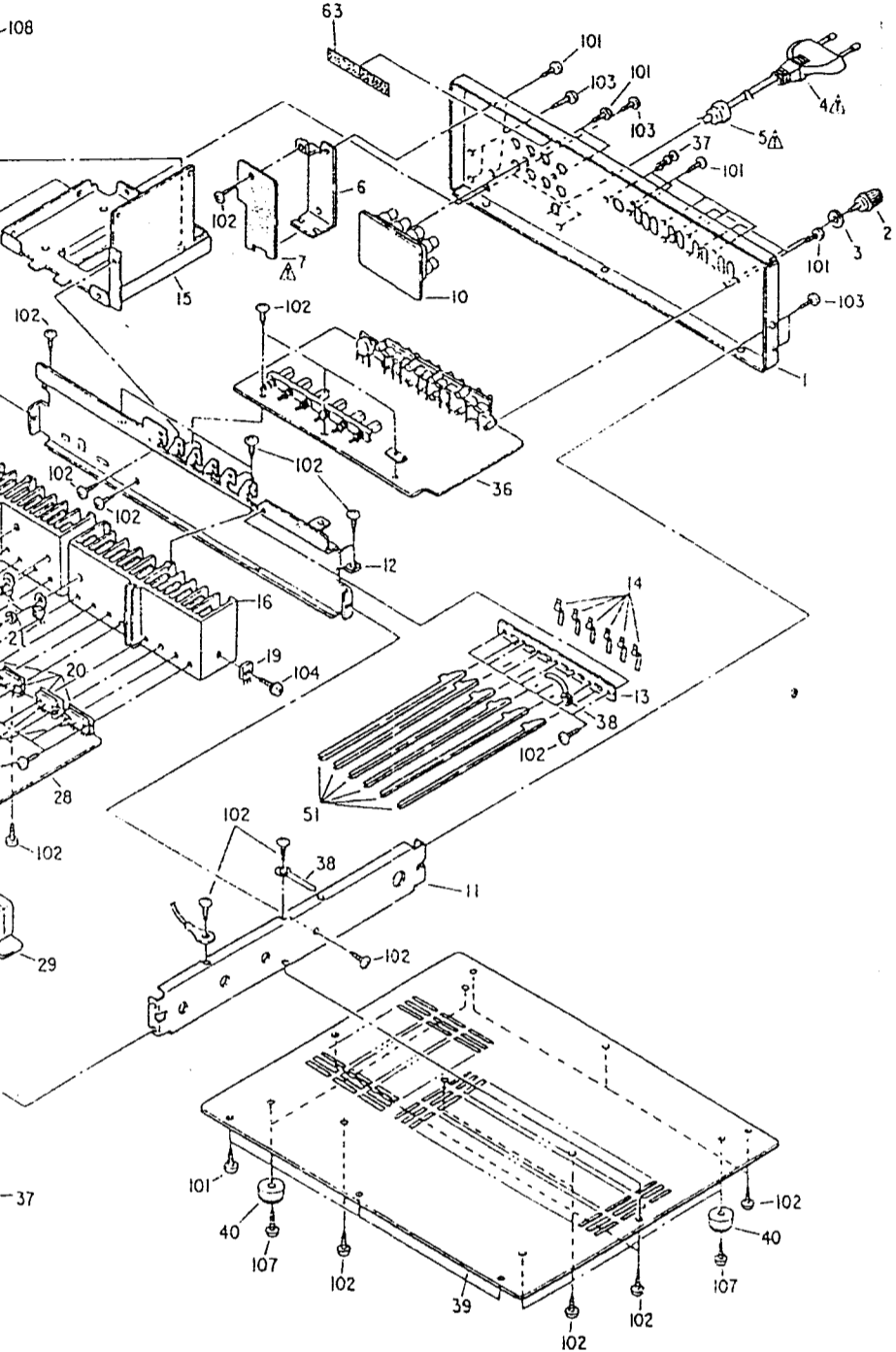

Part Name & Descriptions

COPPER  
SCREW  
KNOB (A)  
KNOB (B)  
CONDENSER BRACKET  
RUBBER SHEET  
RUBBER SHEET  
SCREW

(not included EXPLODED VIEW)

TOP COVER  
CUSHION  
INST. MANUAL  
COLOR LABEL (GOLD)  
CONTROL CARD  
CARTON CASE

Ref. No.	Part No.	Part Name & Descriptions	Qty
SCREWS & NUT			
101	4730354035	TAPPING SCREW (2) 3x8 (BLACK)	22
102	4730354019	TAPPING SCREW (2) 3x8	33
103	4770064107	FIXING SCREW	6
104	4700011023	PAN SCREW WITH W. SPW 3x10	17
105	4711303018	PAN SCREW 3x6	13
107	4730804035	TAPPING SCREW (2) 3x14	4
108	4700031016	TAPPING SCREW WITH TWB 4x10	4
109	4734801005	TAPPING SCREW (TRUS) 4x8	4
110			
111			
112			

ADDENDUM LIST

Ref. No.	Part Name & Descriptions	Part No.					
		E1 for Awa		E3 for U.S.A.		EA for Australia	EK for U.K.
		Gold Version	Black Version	Gold Version	Black Version	Gold Version	Black Version
1	BACK PANEL	1059005000	1059005000	1059002003	1059002003	1050626307	1050626307
7	AC FUSE UNIT	-	-	ETC0740-E3	ETC0740-E3	ETC0740-F3	ETC0740-F3
8	FTZ LABEL	-	-	-	-	-	-
9	APPROVAL MARK	-	-	-	-	-	-
10	SP TERMINAL UNIT	ETC0740-D2	ETC0740-D2	ETC0740-E2	ETC0740-E2	ETC0740-F2	ETC0740-F2
27	HEADPHONE JACK UNIT	ETC0739-D4	ETC0739-D4	ETC0739-E4	ETC0739-E4	ETC0739-F4	ETC0739-F4
28	TONE & POWER UNIT	ETC0738-D	ETC0738-D	ETC0738-E	ETC0738-E	ETC0738-F	ETC0738-F
29	MAIN VR UNIT	ETC0738-D2	ETC0738-D2	ETC0738-E2	ETC0738-E2	ETC0738-F2	ETC0738-F2
34	P.S & PROT. UNIT	ETC0740-D	ETC0740-D	ETC0740-E	ETC0740-E	ETC0740-F1	ETC0740-F1
35	SPEAKER SW UNIT	ETC0739-D2	ETC0739-D2	ETC0739-E2	ETC0739-E2	ETC0739-F2	ETC0739-F2
36	INPUT & EQ. UNIT	ETC0739-D1	ETC0739-D1	ETC0739-E1	ETC0739-E1	ETC0739-F1	ETC0739-F1
37	PUSH RIVET	-	-	-	-	4770096007	4770096007
43	PUSH KNOB (A)	1130515124	1130515121	1130515134	1130515121	1130515134	1130515121
44	PUSH KNOB (B) ASS'Y	1130636000	1130636000	1130450118	1130636000	1130450118	1130636000
45	FRONT PANEL ASS'Y	1441257000	1441257026	1441257000	1441257026	1441257000	1441257026
48	ESC. PLATE	1441256027	1441256027	1441256001	1441256027	1441256001	1441256027
49	LED UNIT	ETC0739-D5	ETC0739-D5	ETC0739-E5	ETC0739-E5	ETC0739-F5	ETC0739-F5
50	LAMP UNIT	ETC0739-D3	ETC0739-D3	ETC0739-E3	ETC0739-E3	ETC0739-F3	ETC0739-F3
52	PUSH KNOB (C)	1130415218	1130415221	1130415218	1130415221	1130415218	1130415221
55	TOP COVER	1020183100	1020183100	1029001005	1029001018	1020183100	1020183100
58	KNOB (A)	1120415011	1120415024	1120415011	1120415024	1120415011	1120415024
59	KNOB (B)	1120416010	1120416023	1120416010	1120416023	1120416010	1120416023
64	CAPACITOR 0.01uF/50V	-	-	-	-	-	-
101	TAPPING SCREW (2) 3x8	4730354035(22)	4730354035(22)	4730354035(24)	4730354035(24)	4730354035(22)	4730354035(22)
109	TAPPING SCREW (TRUS) 4x8	4734801005(4)	4734454038(4)	4734801005(4)	4734454038(4)	4734801005(4)	4734454038(4)
150	PAN SCREW WITH S.W 3x8 BLACK	4700042005(4)	4700042005(4)	-	-	-	-
151	NUT M3	4756006008(2)	4756006008(2)	-	-	-	-
152	WASHER ø5 BLACK	-	-	4751006016(8)	4751006016(8)	-	-
153	TAPPING SCREW (TRUS) 4x20 BLACK	-	-	4734460035(8)	4734460035(8)	-	-
154	TOOTH WASHER ø3	-	-	-	-	4753001051(8)	4753001051(8)
155	3T LUG	-	-	-	-	2050003107(1)	2050003107(1)
156	TOOTH WASHER ø4	-	-	-	-	4753100004(8)	4753100004(8)
205	FUSE LABEL	5130654062	5130654082	-	-	-	-
206	FUSE LABEL	5130654075	5130654075	-	-	-	-
207	VOLTAGE SELECTOR SWITCH	5130784000	5130784000	-	-	-	-
208	FUSE LABEL	-	-	5139115007	5139115007	-	-
209	FUSE LABEL	-	-	5130607019	5130607019	-	-
210	RUBBER SHEET	-	-	4610066139	4610066139	-	-
211	DANGEROUS MARK	-	-	5138266009	5138266009	-	-
212	SERIAL NO. PLATE	-	-	5130885022	5130885022	-	-
213	RIVET	-	-	4770126016	4770126016	-	-
214	WOOD BOARD (R)	-	-	1011469008	1011469008	-	-
215	WOOD BOARD (L)	-	-	1011470000	1011470000	-	-
216	FELT SHEET	-	-	1240032015	1240032015	-	-
217	INDICATION SHEET	-	-	5130784000	5130784000	-	-
218	NOTICE SHEET	-	-	-	-	5130209006	-
219	NOTICE SHEET	-	-	-	-	5130210008	-
220	VOLTAGE LABEL	-	-	-	-	5130362008	5130362008
221	BLIND SHEET	-	-	-	-	5130348006	5130348006
222	EARTH LABEL	-	-	-	-	5130140000	5130140000
223	CAUTION SHEET	-	-	-	-	-	5130364006
224		-	-	-	-	-	-
225		-	-	-	-	-	-
a	SET COVER	5040084007	5040084007	5058092049	5058092049	5040084007	5040084007
b	CUSHION	5030456001	5030456001	5039107005	5039107005	5030456001	5030456001
d	COLOR LABEL (GOLD)	5139111001	-	5139111001	-	5139111001	-
e	CONTROL CARD	-	-	-	-	-	-
f	CARTON CASE	5010916037	50109160	5019104002	5019104031	5010916066	5010916037
g	COLOR LABEL (BLACK)	-	5139111014	-	5139111014	-	5139111014
h	WARRANTY IN ENVELOPE	5158053108	5158053108	5158053108	5158053108	-	-
i	PROTECTOR SHEET	-	-	5040077056	5040077056	-	-
j	SAFETY INSTRUCTION	-	-	5111041005	5111041005	-	-
k	CAUTION PAPER	-	-	-	-	5130211007	-
m	IMPORTANT LABEL	-	-	-	-	-	513037
n		-	-	-	-	-	-

BLACK VERSION PARTS LIST  
(Same as SILVER VERSION except the followings.)

Ref. No.	Part No.	Part Name & Descriptions
43	1130515121	PUSH KNOB (A)
44	1130636000	PUSH KNOB (B)
45	1441257026	FRONT PANEL ASS'Y
48	1441256027	ESC. PLATE
52	1130415221	PUSH KNOB (C)
55	1020183100	TOP COVER
58	1120415024	KNOB (A)
59	1120416023	KNOB (B)
100	4734454038	TAPPING SCREW (2) 4x8
d.	5139111014	COLOR LABEL (BLACK)

EXPLODED VIEW OF CHASSIS AND CABINET

• PMA-757

Means important safety item, which when necessary, by a part specified or marked by the manufacturer.

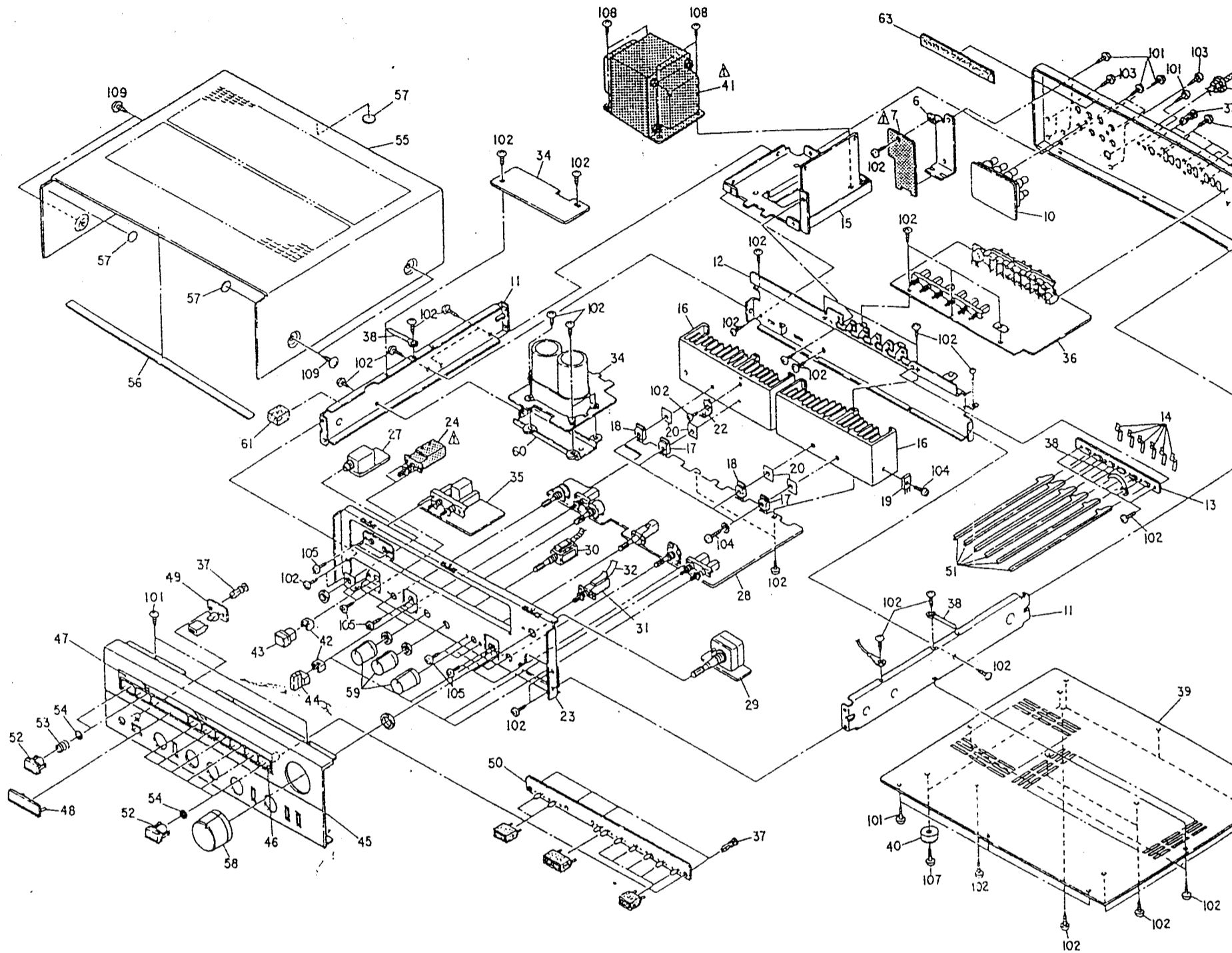

Note: 1. See addendum list below for the parts with asterisk (\*) on the Ref. No. and the other parts not included in this list.  
 2. The list is prepared based on E2 Silver Version.  
 3. \* Marked not included EXPLODED VIEW.  
 4. o Marked same as PMA-777E2.

EXPLODED VIEW OF PARTS LIST

Ref. No.	Part No.	Part Name & Descriptions
*1	1050626310	BACK PANEL
*2	2050071016	TERMINAL ASS'Y
*3	4770018001	WASHER (P-87)
4	4410455005	PWB BRACKET
5	4410455005	PWB BRACKET
*8	5130716023	FTZ LABEL
*9	5138253009	APPROVAL MARK
*10	ETC0740-82	SP TERMINAL UNIT
*11	4120733606	SIDE CHASSIS
*12	4110375317	MAIN CHASSIS
*13	4410378108	SHEET
*14	4630337000	SPRING
*15	4110334206	TRANS CHASSIS ASS'Y
*16	4170156301	POWER RADIATOR
*17	2730305002	TRANSISTOR 2SC3284(O)/(Y)
*18	2710184007	TRANSISTOR 2SA1303(O)/(Y)
*19	2740088018	TRANSISTOR 2SD1406(Y)/(GR)
*20	4150234007	INSULATING SHEET
*21	-	-
*22	4410411104	PCB BRACKET
*23	4110429302	FRONT CHASSIS
24	4410429302	FRONT CHASSIS
25	4410429302	FRONT CHASSIS
*26	4450033005	WIRE CLAMP BAND USED 36
*27	ETC0739-B4	HEADPHONE JACK UNIT

Ref. No.	Part No.	Part Name & Descriptions
*28	ETC0738-B1	TONE & POWER UNIT
*29	ETC0738-B2	MAIN VR UNIT
*30	2120222009	ROTARY REMOTE
*31	2124484005	1P-PUSH REMOTE
*32	4350052005	FLEXIBLE SLIDER (MM, MC)
33	-	-
*34	ETC0740B	P.S & PROT. UNIT
*35	ETC0739-B2	SPEAKER SW UNIT
*36	ETC0739-B1	INPUT & EQ. UNIT
*37	4770096007	PUSH RIVET
*38	EP-6214	CORD HOLDER USED 6
*39	1050450609	BOTTOM COVER
*40	1040110001	FOOT
41	2230487008	POWER TRANS
*42	1140056007	FLEXIBLE RING
*43	1130515134	PUSH KNOB (A)
*44	1130450118	PUSH KNOB (B) ASS'Y
*45	1441257013	FRONT PANEL ASS'Y
*46	1430297013	WINDOW
*47	1460556106	WINDOW PANEL
*48	1441256014	ESC. PLATE
*49	ETC0739-B5	LED UNIT
*50	ETC0739-B3	LAMP UNIT
*51	4121069007	CONNECTING BRACKET
*52	1130415218	PUSH KNOB (C)
*53	4630274011	SPRING
*54	1220039012	SPACER

Ref. No.	Part No.	Part Name & Descriptions
*55	1020183100	TOP COVER
*56	1220069008	SPACER
*57	1040034006	STOPPER
*58	1120415011	KNOB (A)
*59	1120416010	KNOB (B)
*60	4120952102	CONDENSER BRACKET
*61	4610223024	RUBBER SHEET
62	-	-
*63	1220069066	SPACER
64	-	-
65	-	-
66	-	-
67	-	-
68	-	-
69	-	-
70	-	-
PACKING & ACCESSORIES (not included EXPLODED VIEW)		
a.	5040084007	SET COVER
b.	5030456001	CUSHION
c.	5111253107	INST. MANUAL
d.	5139111001	COLOR LABEL (GOLD)
e.	5138295009	CONTROL CARD
f.	5010916040	CARTON CASE

Ref. No.	Part No.	Part Name & Descriptions	Qty
SCREWS & NUT			
*101	4730354035	TAPPING SCREW (2) 3x8 (BLACK)	22
*102	4730354019	TAPPING SCREW (2) 3x8	33
*103	4770064107	FIXING SCREW	6
*104	4700012022	PAN SCREW WITH W. SPW 3x12	5
*105	4711303018	PAN SCREW 3x6	12
106	-	-	-
*107	4730804035	TAPPING SCREW (2) 3x14	4
*108	4700031016	TAPPING SCREW WITH TWB 4x10	4
*109	4734801005	TAPPING SCREW (TRUS) 4x8	4
110	-	-	-
111	-	-	-
112	-	-	-

△ Means important safety item, which must be replaced, when necessary, by a part specified or meeting the specification by the manufacturer.

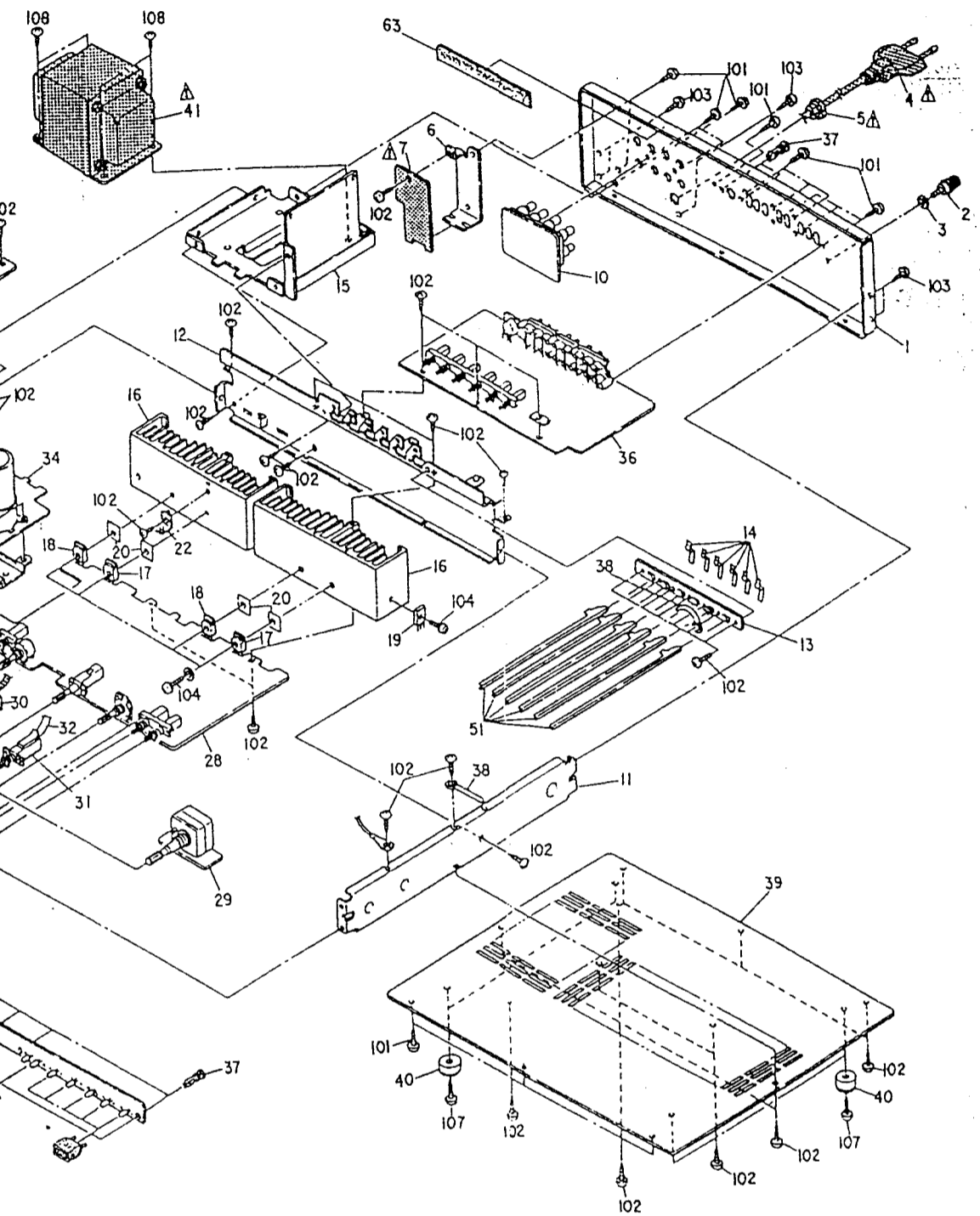

Part No.	Part Name & Descriptions
1020183100	TOP COVER
1220069008	SPACER
140034006	STOPPER
120415011	KNOB (A)
120416010	KNOB (B)
120952102	CONDENSER BRACKET
1510223024	RUBBER SHEET
1220069066	SPACER
ACCESSORIES (not included EXPLODED VIEW)	
1040084007	SET COVER
1030456001	CUSHION
111253107	INST. MANUAL
1139111001	COLOR LABEL (GOLD)
1138295009	CONTROL CARD
1010916040	CARTON CASE

Ref. No.	Part No.	Part Name & Descriptions	Qty
SCREWS & NUT			
••	101	4730354035 TAPPING SCREW (2) 3x8 (BLACK)	22
•	102	4730354019 TAPPING SCREW (2) 3x8	33
•	103	4770064107 FIXING SCREW	6
•	104	4700012022 PAN SCREW WITH W. SPW 3x12	5
•	106	4711303018 PAN SCREW 3x6	12
•	107	4730804035 TAPPING SCREW (2) 3x14	4
•	108	4700031016 TAPPING SCREW WITH TWB 4x10	4
•	109	4734801005 TAPPING SCREW (TRUS) 4x8	4
	110		
	111		
	112		

### ADDENDUM LIST

Ref. No.	Part Name & Descriptions	Part No.					
		E1 for Asia		E2 for U.S.A.		EC for Canada	EA for Australia
		Gold Version	Black Version	Gold Version	Black Version	Black Version	Gold Version
1	BACK PANEL	1069034001	1069004001	1069001004	1069001004	1069016002	1069026310
6	PWB BRACKET	-	-	4410456005	4410456006	4410456005	4410456006
8	FTZ LABEL	-	-	-	-	-	-
9	APPROVAL MARK	-	-	-	-	-	-
10	SP TERMINAL UNIT	ETC0740-M2	ETC0740-M2	ETC0740-N2	ETC0740-N2	ETC0740-N2	ETC0740-P2
17	TRANSISTOR	2740103003	2740103003	2740103003	2740103003	2740103003	2740103003
18	TRANSISTOR	(2SD1110(RI)/(OI))	(2SD1110(RI)/(OI))	(2SD1110(RI)/(OI))	(2SD1110(RI)/(OI))	(2SD1110(RI)/(OI))	(2SD1110(RI)/(OI))
20	INSULATING SHEET	2720074000	2720074000	2720074000	2720074000	2720074000	2720074000
27	HEADPHONE JACK UNIT	(2S8849(RI)/(OI))	(2S8849(RI)/(OI))	(2S8849(RI)/(OI))	(2S8849(RI)/(OI))	(2S8849(RI)/(OI))	(2S8849(RI)/(OI))
28	LED UNIT	4150234007	4150234007	4150234007	4150234007	4150234007	4150234007
29	TONE & POWER UNIT	ETC0739-M4	ETC0739-M4	ETC0739-N4	ETC0739-N4	ETC0739-N4	ETC0739-P4
30	MAIN VR UNIT	ETC0738-M	ETC0738-M	ETC0738-N	ETC0738-N	ETC0738-N	ETC0738-P
31	P.S. & PROT. UNIT	ETC0740-M	ETC0740-M	ETC0740-N	ETC0740-N	ETC0740-N	ETC0740-P
32	SPLAKER SW UNIT	ETC0739-M2	ETC0739-M2	ETC0739-N2	ETC0739-N2	ETC0739-N2	ETC0739-P2
33	INPUT & EQ. UNIT	ETC0739-M1	ETC0739-M1	ETC0739-N1	ETC0739-N1	ETC0739-N1	ETC0739-P1
34	PUSH RIVET	-	-	-	-	-	-
43	PUSH KNOB (A)	1130615134	1130615121	1130615134	1130615121	1130615121	1130615134
44	PUSH KNOB (B) ASS'Y	1130636000	1130636000	1130636000	1130636000	1130636000	1130636000
45	FRONT PANEL ASS'Y	1441257039	1441257039	1441257039	1441257039	1441257039	1441257039
48	ESC. PLATE	1441256030	1441256030	1441256030	1441256030	1441256030	1441256030
49	LED UNIT	ETC0739-M5	ETC0739-M5	ETC0739-N5	ETC0739-N5	ETC0739-N5	ETC0739-P5
49	LAMP UNIT	ETC0739-M3	ETC0739-M3	ETC0739-N3	ETC0739-N3	ETC0739-N3	ETC0739-P3
50	PUSH KNOB (C)	1130415221	1130415221	1130415221	1130415221	1130415221	1130415221
52	TOP COVER with Wood Board	1020183100	1020183100	1020183100	1020183100	1020183100	1020183100
55	TOP COVER without Wood Board	1120415024	1120415024	1120415024	1120415024	1120415024	1120415024
58	KNOB (A)	1120415011	1120415011	1120415011	1120415011	1120415011	1120415011
59	KNOB (B)	1120416023	1120416023	1120416023	1120416023	1120416023	1120416023
64	CAPACITOR (12000F/500V)	-	-	-	-	-	-
101	TAPPING SCREW (2) 3x8	4730354035(21)	4730354035(21)	4730354035(24)	4730354035(24)	4730354035(24)	4730354035(22)
109	TAPPING SCREW (TRUS) 4x8	4734801005(4)	4734801005(4)	4734801005(4)	4734801005(4)	4734801005(4)	4734801005(4)
150	PAN SCREW WITH S.W 3x8 BLACK	4700042005(2)	4700042005(2)	-	-	-	-
151	NUT M3	4756006008(2)	4756006008(2)	-	-	-	-
152	WASHER #5 BLACK	4751006016(8)	-	-	-	-	-
153	TAPPING SCREW (TRUS) 4x20 BLACK	4734800035(8)	-	-	-	-	-
154	TOOTH WASHER #2	-	-	-	-	-	4753001051(5)
155	3T LUG	-	-	-	-	-	2050003107(3)
156	TOOTH WASHER #4	-	-	-	-	-	4753100004(8)
205	FUSE LABEL	5130654058	5130654058	-	-	-	-
206	FUSE LABEL (TS,JA)	5130654091	5130654091	-	-	-	-
208	FUSE LABEL	-	-	5139115010	5139115010	5139115010	-
209	FUSE LABEL	-	-	5130607022	5130607022	5130607022	-
210	RUBBER SHEET with Wood Board	4610066139	-	-	-	-	-
211	DANGEROUS MARK SERIAL NO. PLATE	-	-	5138266009	5138266009	-	-
212	RIVET	-	-	5130885019	5130885019	-	-
213	WOOD BOARD (R)	1011489008	-	4770126016	4770126016	-	-
214	WOOD BOARD (L) with Wood Board	1011470000	-	-	-	-	-
216	FELT SHEET	1240032015	-	-	-	-	-
217	INDICATION SHEET	5130784000	-	-	-	-	-
218	NOTICE SHEET	-	-	-	-	-	5130209006
219	NOTICE SHEET	-	-	-	-	-	5130210008
220	VOLTAGE LABEL	-	-	-	-	-	5130362008
221	BLIND SHEET	-	-	-	-	-	5130348006
222	EARTH LABEL	-	-	-	-	-	5130140000
223	CAUTION SHEET	-	-	-	-	5139101008	-
224	CAUTION LABEL	-	-	-	-	5138311006	-
225	CSA LABEL	-	-	-	-	-	-
a	SET COVER with Wood Board	5058092049	5040084007	5040084007	5040084007	5040084007	5040084007
b	SET COVER without Wood Board	5040084007	-	-	-	-	-
c	CUSHION with Wood Board	5030456001	5030456001	5030456001	5030456001	5030456001	5030456001
d	CUSHION without Wood Board	5030456001	-	-	-	-	-
e	COLOR LABEL (GOLD)	5139111001	-	5139111001	-	-	5139111001
f	CONTROL CARD	-	-	-	-	-	-
g	CARTON CASE with Wood Board	5019104015	5019104040	5019104044	5019104028	5017916040	5017916040
h	CARTON CASE without Wood Board	5010916040	-	-	-	-	-
i	COLOR LABEL (BLACK) WARRANTY IN ENVELOPE	-	5139111014	-	5139111014	5139111014	-
j	PROTECTOR SHEET	5130603103	5139042103	5139042102	5139042103	-	-
k	SAFETY INSTRUCTION	-	-	5111041005	5111041005	-	-
l	PAD	-	-	-	-	-	5020556018
m	CAUTION PAPER	-	-	-	-	-	5130211007
n	IMPORTANT LABEL	-	-	-	-	-	-
o	PRESET LABEL	5150290008	-	-	-	-	-
p	WARRANTY IN ENVELOPE with Wood Board	-	-	-	-	-	-

E1: with Wood Board, E1: without Wood Board

### BLACK VERSION PARTS LIST (Same as SILVER VERSION except the followings.)

Ref. No.	Part No.	Part Name & Descriptions
43	1130615121	PUSH KNOB (A)
44	1130636000	PUSH KNOB (B)
45	1441257039	FRONT PANEL ASS'Y
48	1441256030	ESC. PLATE
52	1130415221	PUSH KNOB (C)
55	1020183100	TOP COVER
58	1120415024	KNOB (A)
59	1120416023	KNOB (B)
109	4734454038	TAPPING SCREW (2) 4x8
d.	5139111014	COLOR LABEL (BLACK)

Ref. No.	Part No.	Part Name & Descriptions
	254130053	150ohm ±5% 1/4W CARBON (FR)
	25410002	150ohm ±5% 1/4W CARBON (NB)
	25413008	100ohm ±5% 1/4W CARBON (FR)
	2440029021	100ohm ±5% 1W METAL OXIDE (NB)
	25413082	47ohm ±5% 1/4W CARBON (FR)
	244029003	0.22ohm ±5% 2W METAL OXIDE (NB)
	25412371016	22ohm ±5% 1/4W CARBON (NB)
	24402314007	100ohm ±5% 1/4W CARBON (NB)
VR201	2110424008	VARIABLE RESISTOR 100k ohm MAIN
VR202	2110198004	VARIABLE RESISTOR 250k ohm BALANCE
VR203	2110309107	VARIABLE RESISTOR 50k ohm TREBLE
VR204	2110309110	VARIABLE RESISTOR 100k ohm BASS
VR301, 302	2116025087	SEMI-FIXED RESISTOR 4.7k ohm IDLE
VR303, 304	2116025016	SEMI-FIXED RESISTOR 100 ohm DISTORTION
CAPACITORS (not included Ceramic ±5%, ±10%, 50V Type)		
C201,	2554193005	0.1μF ±5% 50V PLASTIC FILM
202	2554191007	0.082μF ±5% 50V PLASTIC FILM
C203,	2554161008	0.0047μF ±5% 50V PLASTIC FILM
204	2544146004	1μF ±20% 50V ELECTROLYTIC
C209,	2554079048	0.01μF ±5% 100V PLASTIC FILM
210	2534266004	7pF ±0.25pF 500V CERAMIC
C213,	2544181001	1μF ±20% 100V ELECTROLYTIC
214	2554165004	0.0068μF ±5% 50V PLASTIC FILM
C215,	2554187008	0.056μF ±5% 50V PLASTIC FILM
216	2554147006	0.0012μF ±5% 50V PLASTIC FILM
C217,	2554183002	0.039μF ±5% 50V PLASTIC FILM
218	2551122095	0.27μF ±5% 50V PLASTIC FILM
C219,	2543016067	10μF ±20% 50V ELECTROLYTIC (8. POLE)
220	2544181001	1μF ±20% 100V ELECTROLYTIC
C223,	2544089022	100μF ±20% 50V ELECTROLYTIC
224	2544146004	1μF ±20% 50V ELECTROLYTIC
C225,	2554149004	0.0015μF ±5% 50V PLASTIC FILM
226	2534482008	33pF ±5% 500V CERAMIC
C229,		
230		
C231,		
232		
C233,		
234		
C239,		
240		
C241		
243		
C301		
304		
C311		
326		
C327		
330		
C331		
334		

Ref. No.	Part No.	Part Name & Descriptions
C339	2554169000	0.01μF ±5% 50V PLASTIC FILM
~342		
C343	2561030070	0.1μF ±5% 100V PLASTIC FILM
~346		
SWITCHES		
SW201	2120221000	ROTARY SWITCH MODE
SW202	2124511004	2P PUSH SWITCH LOUD. SUB.
SW203	2124462001	1P PUSH SWITCH DIRECT
OTHER PARTS		
	2221090101	P.W. BOARD
	EP-5667H1	TERMINAL PIN USED 40
	2090008120	JUMPER WIRE P=10mm USED 60
	2036105032	4P CONNECTOR CORD
	2030230039	1P CONNECTOR
	2050185038	3P WIRE HOLDER USED 6
	2050185041	4P WIRE HOLDER
	2050185054	5P WIRE HOLDER USED 2
	4711303018	3x6 CPS USED 2
	4756006008	3IN USED 2