

DENON

Hi-Fi Pre-Main Amplifier

SERVICE MANUAL MODEL PMA-950 PRE MAIN AMPLIFIER

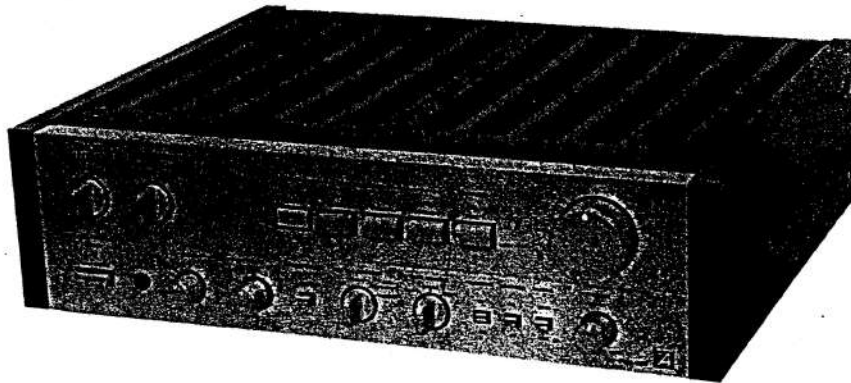

CONTENTS

SPECIFICATIONS	1
BLOCK DIAGRAM	2
METHOD OF ADJUSTMENTS	3
CONNECTION DIAGRAM	4
EXPLODED VIEW OF CABINET & CHASSIS	5
EXPLODED VIEW OF PARTS LIST	6
PRINTED CIRCUIT BOARD PATTERNS AND PARTS LIST	
INPUT & EQ. UNIT ETC-430B	7
CONTROL UNIT ETC-431B	9
POWER AMP. UNIT PUS-029	11
POWER SUPPLY & PROTECTOR UNIT ETC-432	15
WIRING DIAGRAM	16

NIPPON COLUMBIA CO., LTD.

SPECIFICATIONS

POWER AMPLIFIER SECTION (TUNER → SP OUT)

Rated Output:	Both channels driven
Subject to Change by	
Temperature Test:	20 Hz ~ 20 kHz 80 W + 80 W (8 ohm load)
	1 kHz 100 W + 100 W (4 ohm load)
Total Harmonic Distortion:	Less than 0.004% Less than 0.01% (USA)
Intermodulation Distortion:	7 kHz/60 Hz : 1/4 at amplitude output equivalent to rated output Less than 0.004% Less than 0.01% (USA)
Output Band Width:	5 Hz ~ 100 kHz (IHF, T.H.D 0.03%)
Transmission	
Characteristics:	1 Hz ~ 250 kHz $^{+0}_{-3}$ dB (at 1 W output)
Input Sensitivity:	150 mV
Input Impedance:	40 k ohm
Output Impedance:	0.1 ohm (1 kHz)
SN Ratio (IHFA Network):	110 dB (Input terminals short- circuited)
Output Terminals:	Speaker: A & B load 4 ~ 16 ohm, A + B load 8 ~ 16 ohm; Head- phone/Stereo headphone (Imped- ance; changeable)

EQUALIZER AMPLIFIER SECTION

Equalizer Amplifier Output

(REC OUT Terminal):	Maximum output 10 V (at 47 k ohm load)
	Rated output 150 mV
	Total harmonic wave distortion: below 0.001% (at 1 kHz, 8 V output)
Input Sensitivity/	
Input Impedance:	PHONO-1MM 2.5 mV 47 k ohm PHONO-2MC 125 μ V 100 ohm TUNER 150 mV 40 k ohm AUX, TAPE 150 mV 40 k ohm

RIAA Deviation:	PHONO-1MM Within ± 0.2 dB
	PHONO-2 (20 Hz ~ 100kHz)
	MC Within ± 0.2 dB (20 Hz ~ 100kHz)

OVERALL CHARACTERISTICS

SN Ratio (IHA Network):	PHONO-1MM 90 dB (Input ter- minals short-circuited, at 2.5 mV input)
	PHONO-2MC 75 dB (Input ter- minals short-circuited, at 250 μ V input)
	TUNER, TAPE, AUX over 110 dB (Input terminals short- circuited)

Tone Control Adjustable

Range:	BASS 100 Hz ± 8 dB
	TREBLE 10 kHz ± 8 dB

Filtering Characteristics:	SUBSONIC 18 Hz, 6 dB/oct
----------------------------	-----------------------------

Loudness Characteristics:	Low Frequency 100 Hz + 7 dB
	High Frequency 10 kHz + 6 dB

AC OUTLET: Not included in systems for
European use.

SWITCHED x 2,100 W (Total)
UNSWITCHED x 1,250 W

POWER SOURCE: 110/120/220/240V (Multiple)

POWER CONSUMPTION: 270 W

DIMENSIONS: 470 mm (W) x 140 mm (H) x
410 mm (D) (including rubber
feet, control knobs, and terminals)

WEIGHT: 14.5 kg

Design and specifications are subject to change without prior notice.

NOTE: The following codes correspond to the appropriate models.
E2 for Europe and E1 for U.S.A., U.K., Hong Kong, Singapore.
This Service Manual is prepared based on E1.

BLOCK DIAGRAM

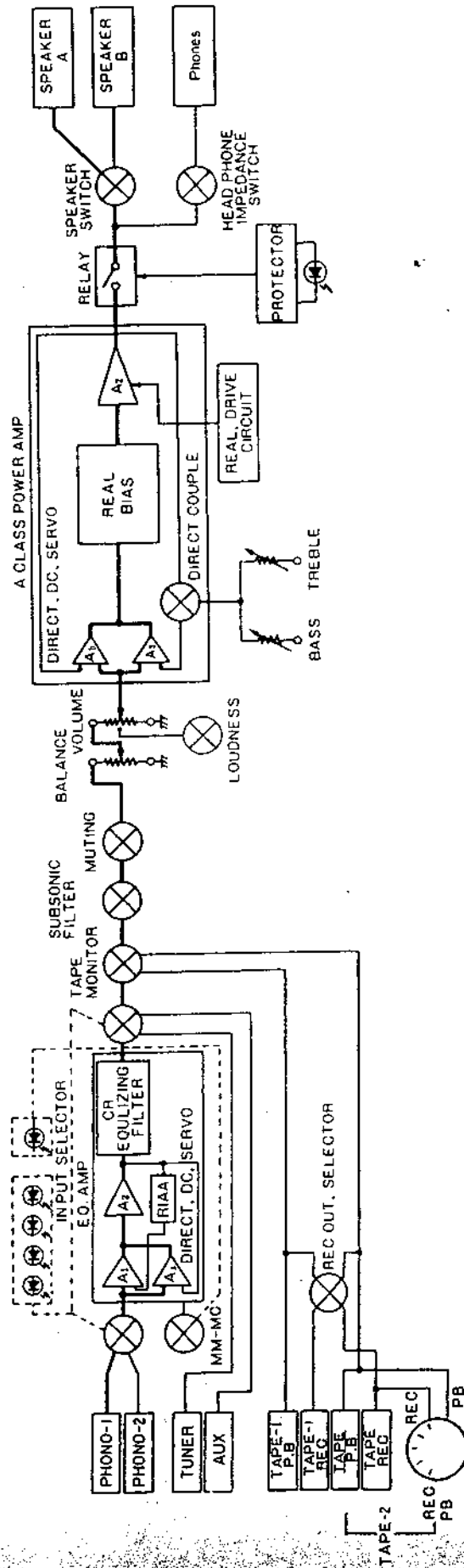

METHOD OF ADJUSTMENT

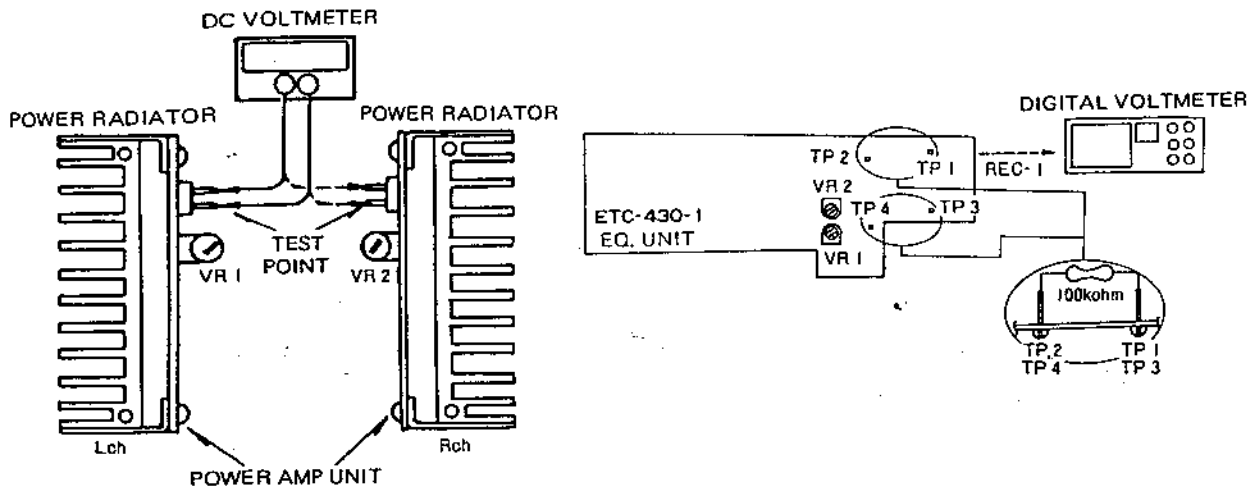

IDLE CURRENT ADJUSTMENT METHOD OF POWER AMP (PUS-029 PRINTED BOARD)

- Place the unit in normal position, not sideways or tilted. Avoid too much ventilation, since the adjustment must be done where temperature is between 15°C and 30°C.
- Set the switches on the unit as follows:

Power	→ OFF
Volume	→ ∞ dB (min.)
Direct couple	→ DIRECT
Speaker terminals	→ No load (no speaker connected)
- Remove the top cover, and the VR1 500 ohm and VR2 500 ohm of the tone & power amp printed board (22207000071) fully counter clockwise. Connect a DC voltmeter to the test points.
- Plug in the AC cord to power outlet of: Europe 220 V (209~231 V); U.K. and Australia 240 V (228~252 V); Canada and U.S.A. 120 V (114~126 V); and turn the power on. Immediately (about after ten seconds), turn VR1 and VR2 clockwise and adjust the test point voltage (V_{TP}) to 50 ± 5 mV preliminarily.
- After about two or three minutes of the above preliminary adjustment, adjust VR1 and VR2 so as V_{TP} reads 80 ± 5 mV.

ADJUSTMENT OF EQUALIZER (ETC-430B PRINTED BOARD)

- Insert short pins into PHONO input terminals.
- Connect a digital voltmeter (0.01 mV ~ 1 mV DC range must be measurable) into each of REC. out terminals (L & R channels).
- For easier measuring to avoid value fluctuation on the meter, connect a 100 k ohm (1/4W) resistor between the ends of the TP1/TP2 and TP3/TP4 on the printed board.
- Set the FUNCTION switch to "MM" position, and turn the main volume to MIN.



ADJUSTMENT

- Turn POWER on, and after two minutes warming-up conduct the following adjustments.
- Adjust VR1 (100 k ohms Semi-Fixed Resistor), so as the L-channel digital voltmeter reads 0.5 mV DC or less.
- Adjust VR2 (100 k ohms Semi-Fixed Resistor), so as the R-channel digital voltmeter reads 0.5 mV DC or less.

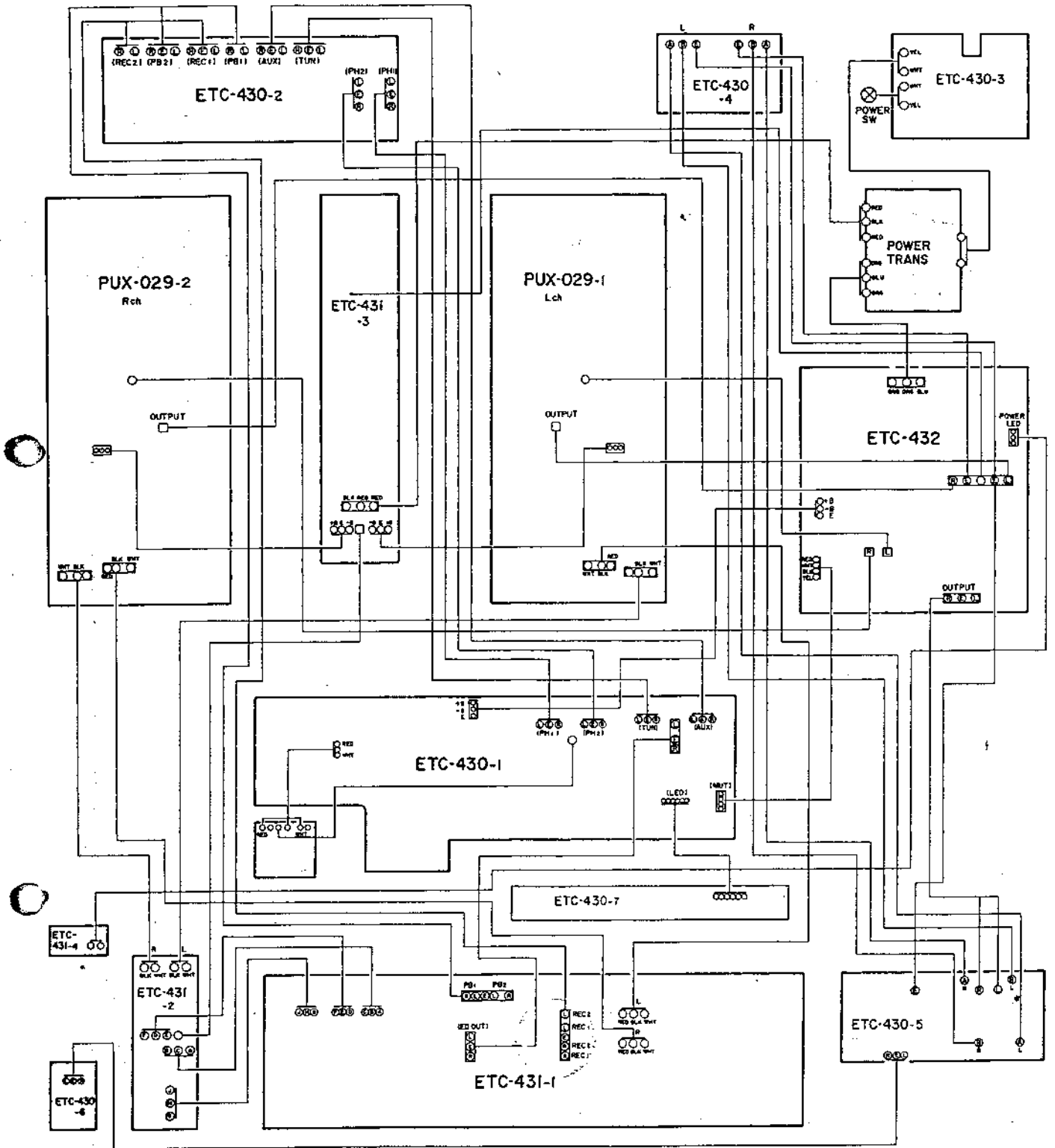
CONNECTION DIAGRAM



EXPLODED VIEW OF CHASSIS AND CABINET

  Means important safety item, which must be replaced, when necessary, by a part specified or meeting the specification by the manufacturer.

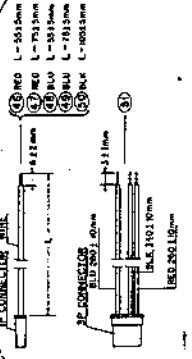
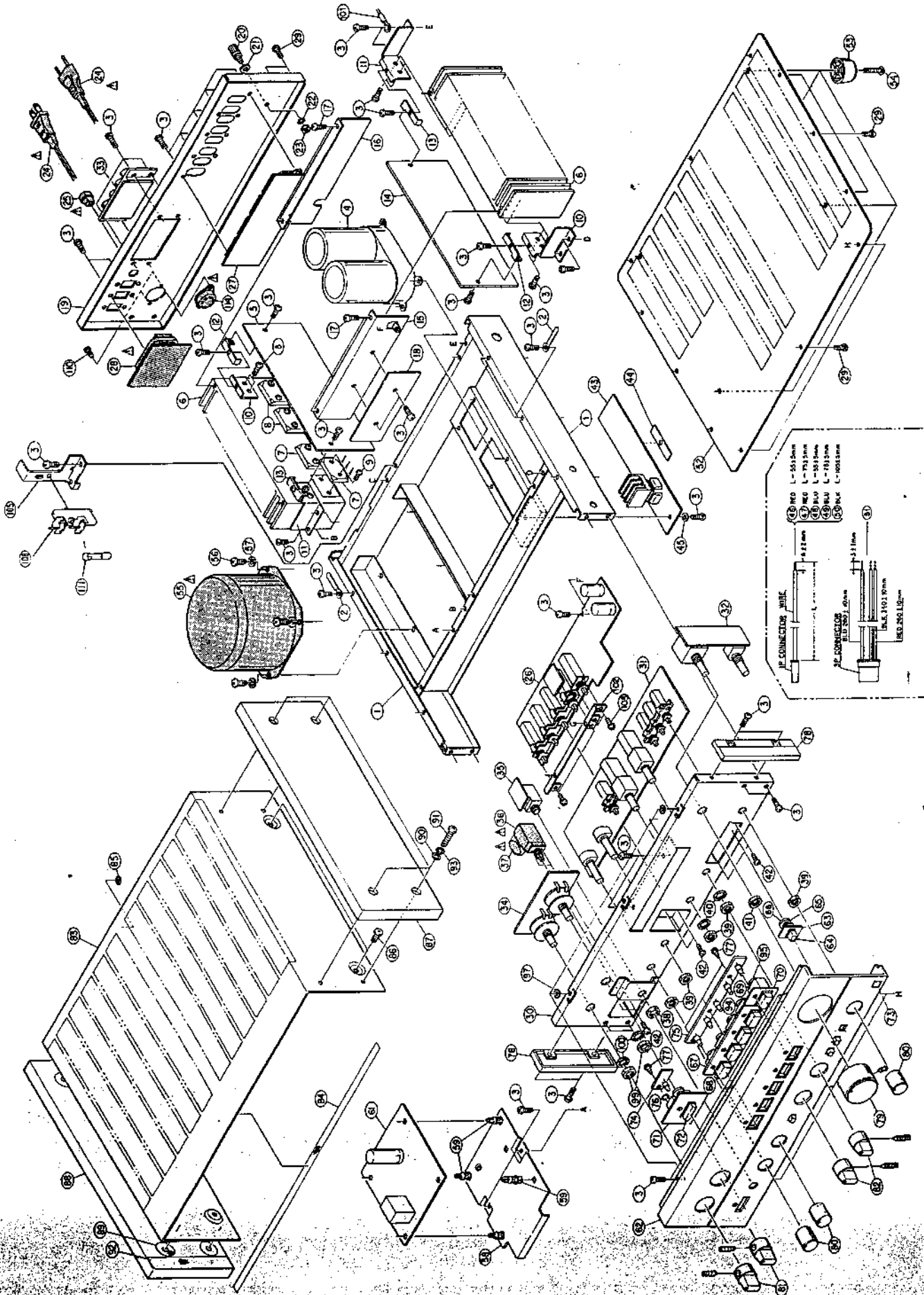

EXPLODED VIEW OF PARTS LIST

Note 1. See addendum list below for the parts with asterisk (*) on the Ref. No. and the other parts not included in this list.

2. This list is prepared based on E1.

Ref. No.	Part No.	Part Name & Descriptions	Ref. No.	Part No.	Part Name & Descriptions
1	4110293004	MAIN CHASSIS ASS.	58	4120725300	BOARD BRACKET
2	EP-4772	CORD HOLDER	59	MD-5271	P.C.B. SUPPORT
3	4730354035	TAPPING SCREW (2)3x8	60	-	-
4	2546027008	CHEMICON 22000µF x 2 63 V	61	ETC-432	POWER SUPPLY & PROTECTOR UNIT
5	PUX-029-1	POWER AMP UNIT	62	1440825006	FRONT PANEL
6	4170139001	POWER RADIATOR	63	1140050003	PANEL BUSH
7	2710145020	TRANSISTOR 2SA1215LB(O)/(Y)	64	1130191105	PUSH KNOB
8	2730247021	TRANSISTOR 2SC2921LB(O)/(Y)	65	4630226014	SPRING
9	4700012022	CROSS PAN SCREW WITH S. WASHER 3x12	66	1190014002	STOPPER
10	4120871005	RADIATOR BRACKET (A)	67	1140054203	PANEL BUSH
11	4120872004	RADIATOR BRACKET (B)	68	1130259102	PUSH KNOB ASS.
12	4120873003	BRACKET (A)	69	4630246007	SPRING
13	4120874002	BRACKET (B)	70	1140057103	PANEL BUSH
14	PUX-029-2	POWER AMP (R) UNIT	71	1140051002	PANEL BUSH (C)
15	4140234208	SHIELD BRACKET (A)	72	1130192007	PUSH KNOB ASS.
16	4140235207	SHIELD BRACKET (B)	73	1350035012	MARK
17	4730353036	TAPPING SCREW (2)3x6 (BLACK)	74	ETC-431B-4	POWER LED UNIT
18	4140236002	SHIELD PLATE	75	ETC-430B-7	INPUT LED UNIT (POWER LED)
*19	1050411004	BACK PANEL	76	4770063108	INSULATING WASHER
20	2050043109	GND TERMINAL	77	4730304014	TAPPING SCREW (1)3x8
21	4770088002	φ4.1 WASHER	78	1460283110	ESC. PLATE
22	4753100004	φ4 TOOTH WASHER	79	1120333106	KNOB (VOLUME)
23	4770006000	M4 NUT	80	1120334008	KNOB (BALANCE, TONE)
24	4770006000	M4 NUT	81	1120335007	KNOB (SPEAKER)
25	4770006000	M4 NUT	82	1120336006	KNOB (TAPE)
26	ETC-430B-1	INPUT & EQ-UNIT (EQ.)	83	1020120008	TOP COVER
27	ETC-430B-2	INPUT & EQ-UNIT (INPUT)	84	1220069008	SPACER
28	ETC-430B-3	INPUT & EQ-UNIT (SPEAKER)	85	1040034006	STOPPER
29	4770064107	FIXING SCREW	86	4734801005	TAPPING SCREW TRUS 4x8
30	4110291103	FRONT CHASSIS	87	1011145005	WOOD BOARD (R)
31	ETC-431B-1	CONTROL UNIT (CONTROL)	88	1011146004	WOOD BOARD (L)
32	ETC-431B-2	CONTROL UNIT (VOLUME)	89	1240032015	FELT SHEET
33	ETC-430B-4	INPUT & EQ. UNIT (SPEAKER TERMINAL)	90	4751006016	φ5 WASHER (BLACK)
34	ETC-430B-5	INPUT & EQ. UNIT (SPEAKER SWITCH)	91	4734460035	TAPPING SCREW TRUS 4x20
35	ETC-430B-6	INPUT & EQ. UNIT (HEADPHONE)	92	1220069037	SPACER
36	2124263022	PHONO SWITCH	93	4751006016	φ4 SPRING WASHER
37	2535003011	CERAMIC CAPACITOR (1000µF 400V)	94	4610167009	CUSHION
38	-	M12 NUT (SPARE)	95	4610156023	SPACER
39	-	M7 NUT (SPARE)	96	-	-
40	-	φ7 TOOTH WASHER (SPARE)	97	-	-
41	-	M8 NUT (SPARE)	98	-	-
42	4711303018	CROSS PAN SCREW 3x6	99	-	M9 NUT (SPARE)
43	ETC-431B-3	CONTROL UNIT (RECT)	100	-	φ9 TOOTH WASHER (SPARE)
44	2050125001	EARTH PLATE	101	2050003000	3T LUG (ETC-430B)
45	4751003006	φ3 WASHER	102	4120875001	5P SWITCH BRACKET (ETC-430B)
46	2030222005	1P CONNECTOR CORD (Lch, +B)	103	4700009006	CROSS PAN SCREW WITH S. WASHER 3x6 (ETC-430B)
47	2030222018	1P CONNECTOR CORD (Rch, +B)	104	-	-
48	2030222021	1P CONNECTOR CORD (Rch, -B)	105	4120892000	BRACKET (A)
49	2030222034	1P CONNECTOR CORD (Lch, -B)	106	-	-
50	2030222047	1P CONNECTOR CORD (E)	107	4150173003	INSULATING SHEET
51	-	-	108	2020011006	FUSE HOLDER
52	1050336215	BOTTOM COVER	109	4120238101	BRACKET
53	1040027107	FOOT	110	4711303034	CROSS PAN SCREW 3x6 (BLACK)
54	4739051009	CROSS PAN SCREW WITH WASHER 3x20	*111	2061025093	FUSE 125V 4A TIME LAG TYPE
55	2335304000	POWER TRANS	112	5130159185	FUSE LABEL (T.4.0A)
56	4730455031	TAPPING SCREW (2) 4x10	113	2048070003	5P. CONNECTOR (DIN)
57	4752004004	φ4 SPRING WASHER	VOLUME SELECTOR SWITCH		
			PACKING & ACCESSORIES		
			5040055007	CABINET SHEET	
			5030281001	CUSHION	
			5010755007	CARTON CASE	
			5110919002	INST. MANUAL	

ADDENDUM LIST

Ref. No.	Part Name	Part No.		Ref. No.	Part Name	Part No.	
		E2 For Europe	E3 For USA, EC For Canada			E2 For Europe	E3 For USA, EC For Canada
19	BACK PANEL	1050434007		75	INPUT & EQ-UNIT (POWER LED)	ETC-4300-7	ETC-430B-7
26	INPUT & EQ-UNIT (EQ.)	ETC-430D-1	ETC-430B-1	115	INSULATING SHEET	4150088004	
27	INPUT & EQ-UNIT (INPUT)	ETC-430D-2	ETC-430B-2	116	7PW TERMINAL	2050089008	
33	INPUT & EQ-UNIT (SPEAKER)	ETC-430D-4	ETC-430B-4	117	C. PAN SCREW WITH S. W. 3x8	4700042005	
34	INPUT & EQ-UNIT (SP. SWITCH)	ETC-430D-5	ETC-430B-5	118	M3 NUT	4756006008	
35	INPUT & EQ-UNIT (H. PHONE)	ETC-430D-6	ETC-430B-6	111	FUSE	2051015087 (4A)	
				119	C. SCREW WITH S. W 3x8 (BLACK)	4700042005	
				120	FUSE LABEL	5130622010 (T.8.0A)	

PRINTED CIRCUIT BOARD PATTERNS AND PARTS LIST

INPUT & EQ. UNIT ETC-430B

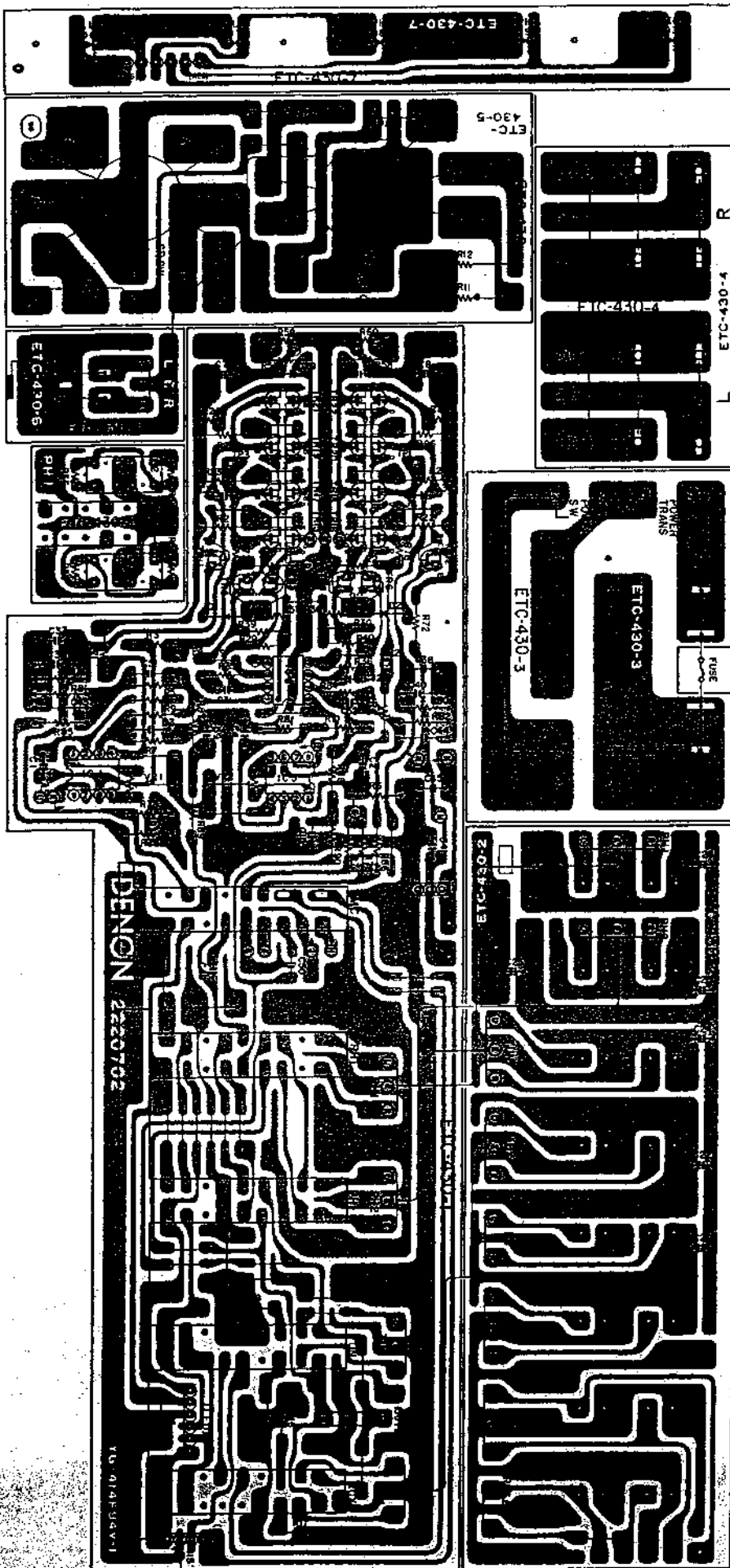

ETC-430B PARTS LIST

Ref. No.	Part No.	Part Name & Descriptions	Ref. No.	Part No.	Part Name & Descriptions
SEMICONDUCTORS					
IC01	2630133002	μPC741C INTEGRATED CIRCUIT	R54	2412002005	220 ohm ±5% 1/4W CARBON FILM STANDING
IC02	2630118001	NJM4560D INTEGRATED CIRCUIT	R55	2412002005	220 ohm ±5% 1/4W CARBON FILM STANDING
IC03	2630133002	μPC741C INTEGRATED CIRCUIT	R56	2412002005	220 ohm ±5% 1/4W CARBON FILM STANDING
TR03	2730198031	2SC1815(BL)/(GR) TRANSISTOR	R57	2412068007	100 ohm ±5% 1/4W CARBON FILM
TR04	2730198031	2SC1815(BL)/(GR) TRANSISTOR	R58	2412068007	100 ohm ±5% 1/4W CARBON FILM
TR05	2730198031	2SC1815(BL)/(GR) TRANSISTOR	R59	2412133000	51 k ohm ±5% 1/4W CARBON FILM
TR06	2730198031	2SC1815(BL)/(GR) TRANSISTOR	R60	2412133000	51 k ohm ±5% 1/4W CARBON FILM
TR11	2710102034	2SA1015(Y)/(GR) TRANSISTOR			
TR12	2710102034	2SA1015(Y)/(GR) TRANSISTOR			
TR15	2750029041	2SK240(GR)/(BL) FIELD EFFECT TRANSISTOR			
TR16	2750029041	2SK240(GR)/(BL) FIELD EFFECT TRANSISTOR			
TR17	2750029041	2SK240(GR)/(BL) FIELD EFFECT TRANSISTOR	R73	2412067008	91 ohm ±5% 1/4W CARBON FILM
TR18	2750029041	2SK240(GR)/(BL) FIELD EFFECT TRANSISTOR	R74	2412067008	91 ohm ±5% 1/4W CARBON FILM
TR19	2750029041	2SK240(GR)/(BL) FIELD EFFECT TRANSISTOR	R75	2412108006	4.7 ohm ±5% 1/4W CARBON FILM
TR20	2750029041	2SK240(GR)/(BL) FIELD EFFECT TRANSISTOR	R76	2412108006	4.7 ohm ±5% 1/4W CARBON FILM
TR21	2750029041	2SK240(GR)/(BL) FIELD EFFECT TRANSISTOR	R77	2412312009	7.5 M ohm ±5% 1/4W CARBON FILM
TR22	2750029041	2SK240(GR)/(BL) FIELD EFFECT TRANSISTOR	R78	2412312009	2.7 M ohm ±5% 1/4W CARBON FILM
D01	2760185001	HZ-4-B3 DIODE	R79	2412106008	3.9 k ohm ±2% 1/4W CARBON FILM
D02	2760185001	HZ-4-B3 DIODE	R80	2412106008	3.9 k ohm ±2% 1/4W CARBON FILM
D03	3939091006	TLY206(YELLOW) LIGHT EMITTING DIODE	R81	2412132001	47 k ohm ±2% 1/4W CARBON FILM
D06	3939040002	TLG206 (GREEN) LIGHT EMITTING DIODE	R82	2412132001	47 k ohm ±2% 1/4W CARBON FILM
D07	3939040002	TLG206 (GREEN) LIGHT EMITTING DIODE	R83	2412060005	47 ohm ±2% 1/4W CARBON FILM
D08	3939040002	TLG206 (GREEN) LIGHT EMITTING DIODE	R84	2412060005	47 ohm ±2% 1/4W CARBON FILM
D09	3939040002	TLG206 (GREEN) LIGHT EMITTING DIODE	R85	2412155004	430 k ohm ±2% 1/4W CARBON FILM
RESISTORS					
VR01	2116025032	SEMI FIXED RESISTOR 100 k ohm	R86	2412155004	430 k ohm ±2% 1/4W CARBON FILM
VR02	2116025032	SEMI FIXED RESISTOR 100 k ohm	R87	2412068007	100 ohm ±2% 1/4W CARBON FILM
R01	2412092002	1 k ohm ±5% 1/4W CARBON FILM	R88	2412068007	100 ohm ±2% 1/4W CARBON FILM
R02	2412092002	1 k ohm ±5% 1/4W CARBON FILM	R89	2412068007	100 ohm ±2% 1/4W CARBON FILM
R03	2412116001	10 k ohm ±5% 1/4W CARBON FILM	R90	2412068007	100 ohm ±2% 1/4W CARBON FILM
R04	2412116001	10 k ohm ±5% 1/4W CARBON FILM			
R05	2412112006	6.8 k ohm ±5% 1/4W CARBON FILM			
R06	2412112006	6.8 k ohm ±5% 1/4W CARBON FILM			
R07	2412116001	10 k ohm ±5% 1/4W CARBON FILM			
R08	2412116001	10 k ohm ±5% 1/4W CARBON FILM			
R09	2412123007	20 k ohm ±5% 1/4W CARBON FILM			
R10	2412123007	20 k ohm ±5% 1/4W CARBON FILM			
R15	2412092002	1 k ohm ±5% 1/4W CARBON FILM			
R16	2412068007	100 ohm ±5% 1/4W CARBON FILM			
R17	2412068007	100 ohm ±5% 1/4W CARBON FILM			
R18	2412068007	100 ohm ±5% 1/4W CARBON FILM			
R19	2412068007	100 ohm ±5% 1/4W CARBON FILM			
R21	2412098006	1.8 k ohm ±5% 1/4W CARBON FILM			
R22	2412098006	1.8 k ohm ±5% 1/4W CARBON FILM			
R23	2412098006	1.8 k ohm ±5% 1/4W CARBON FILM			
R24	2412098006	1.8 k ohm ±5% 1/4W CARBON FILM			
R25	2412098006	1.8 k ohm ±5% 1/4W CARBON FILM			
R26	2412098006	1.8 k ohm ±5% 1/4W CARBON FILM			
R27	2412020016	1.8 k ohm ±5% 1/4W CARBON FILM STANDING			
R28	2412020016	1.8 k ohm ±5% 1/4W CARBON FILM STANDING			
R35	2412076002	220 ohm ±5% 1/4W CARBON FILM			
R36	2412076002	220 ohm ±5% 1/4W CARBON FILM			
R37	2412022043	22 k ohm ±5% 1/4W CARBON FILM STANDING			
R38	2412022043	22 k ohm ±5% 1/4W CARBON FILM STANDING			
R53	2412002005	220 ohm ±5% 1/4W CARBON FILM STANDING			
CAPACITORS					
C01	2544003008	100μF 6.3VELECTROLYTIC			
C02	2544003008	100μF 6.3VELECTROLYTIC			
C03	2561017019	0.01μF ±10% 630V METALIZED			
C04	2561017019	0.01μF ±10% 630V METALIZED			
C07	2544013001	470μF 10V ELECTROLYTIC			
C08	2544013001	470μF 10V ELECTROLYTIC			
C09	2556160078	0.0068μF ±5% 50V PLASTIC FILM FORMING			
C10	2556160078	0.0068μF ±5% 50V PLASTIC FILM FORMING			
C15	2544044009	1μF 50V ELECTROLYTIC			
C21	2544043000	0.47μF 50V ELECTROLYTIC			
C22	2544043000	0.47μF 50V ELECTROLYTIC			
C23	2544043000	0.47μF 50V ELECTROLYTIC			
C24	2544043000	0.47μF 50V ELECTROLYTIC			
C25	2544043000	0.47μF 50V ELECTROLYTIC			
C26	2544043000	0.47μF 50V ELECTROLYTIC			
C29	2556159018	120pF ±5% 50V PLASTIC FILM FORMING			
C30	2556159018	120pF ±5% 50V PLASTIC FILM FORMING			
C31	2554149004	0.0015μF ±5% 50V PLASTIC FILM			
C32	2554149004	0.0015μF ±5% 50V PLASTIC FILM			
C35	2541035008	1μF ±20% 35V ELECTROLYTIC			
C36	2541035008	1μF ±20% 35V ELECTROLYTIC			
C37	2554070018	0.001μF ±1% 100V PLASTIC FILM			
C38	2554070018	0.001μF ±1% 100V PLASTIC FILM			
C39	2554083034	0.018μF ±2% 100V PLASTIC FILM			
C40	2554083034	0.018μF ±2% 100V PLASTIC FILM			
C41	2544038002	100μF 35V ELECTROLYTIC			
C43	2554083047	0.068μF ±2% 100V PLASTIC FILM			
C44	2554083047	0.068μF ±2% 100V PLASTIC FILM			
C45	2544038002	100μF 35V ELECTROLYTIC			
C49	2556160081	0.0075μF ±5% 50V PLASTIC FILM FORMING			
C50	2556160081	0.0075μF ±5% 50V PLASTIC FILM FORMING			
C51	2556159092	470pF ±5% 50V PLASTIC FILM FORMING			
C52	2556159092	470pF ±5% 50V PLASTIC FILM FORMING			
C55	2544044009	1μF 50V ELECTROLYTIC			
C56	2544044009	1μF 50V ELECTROLYTIC			
OTHER PARTS					
	2220702102	P.W. BOARD			
	2090047903	0.6 JUMPER WIRE SHORTLEAD USED 25			
	2090008133	JUMPER SHOTLEAD USED 11			
	EP-6687H1	TERMINAL WRAPPING PIN USED 8			
SW01	2120187005	ROTARY SWITCH FOR SPEAKER			
SW02	2120188004	ROTARY SWITCH FOR H.P. IMPEDANCE			
SW03	2124290008	4P. PUSH SWITCH FOR FUNCTION			

(Con.)

Ref. No.	Part No.	Part Name & Descriptions	Ref. No.	Part No.	Part Name & Description
SW04	2124291007	1P. PUSH SWITCH FOR MC-MM		2034152029	3P. CONTACT WIRE ASS. FOR TON
	2033909008	AC OUTLET		2034152032	3P. CONTACT WIRE ASS. FOR AUX
	2050070004	8P. TERMINAL FOR SPEAKER		2038092004	5P. CONNECTOR CORD FOR REC
	EP-5870	FUSE HOLDER USED 2		2038093003	5P. CONNECTOR CORD FOR PB
	2061017027	FUSE 8A		2040075019	6P. CONNECTOR CORD FOR LED
	2048045009	4P. PIN JACK		4120875001	5P. SWITCH BRACKET
	2048078005	4P. CONNECTOR BASE ASS.		4700009006	CROSS PAN SCREW WITH S. WASHER 3x6
	2050122033	3P. CONNECTOR PIN ASS.	L01	4450033005	WIRE CLAMP BAND
	2035622024	4P. MINI CONN. PIN	L02	2318017000	INDUCTOR
	2035622008	3P. CONN. BASE	L03	2318017000	INDUCTOR
	2035622082	6P. CONN. BASE	L04	2318017000	INDUCTOR
	2050003000	3T LUG			
	2034152003	3P. CONTACT WIRE ASS. FOR PH1			
	2034152016	3P. CONTACT WIRE ASS. FOR PH2			

CONTROL UNIT ETC-431B

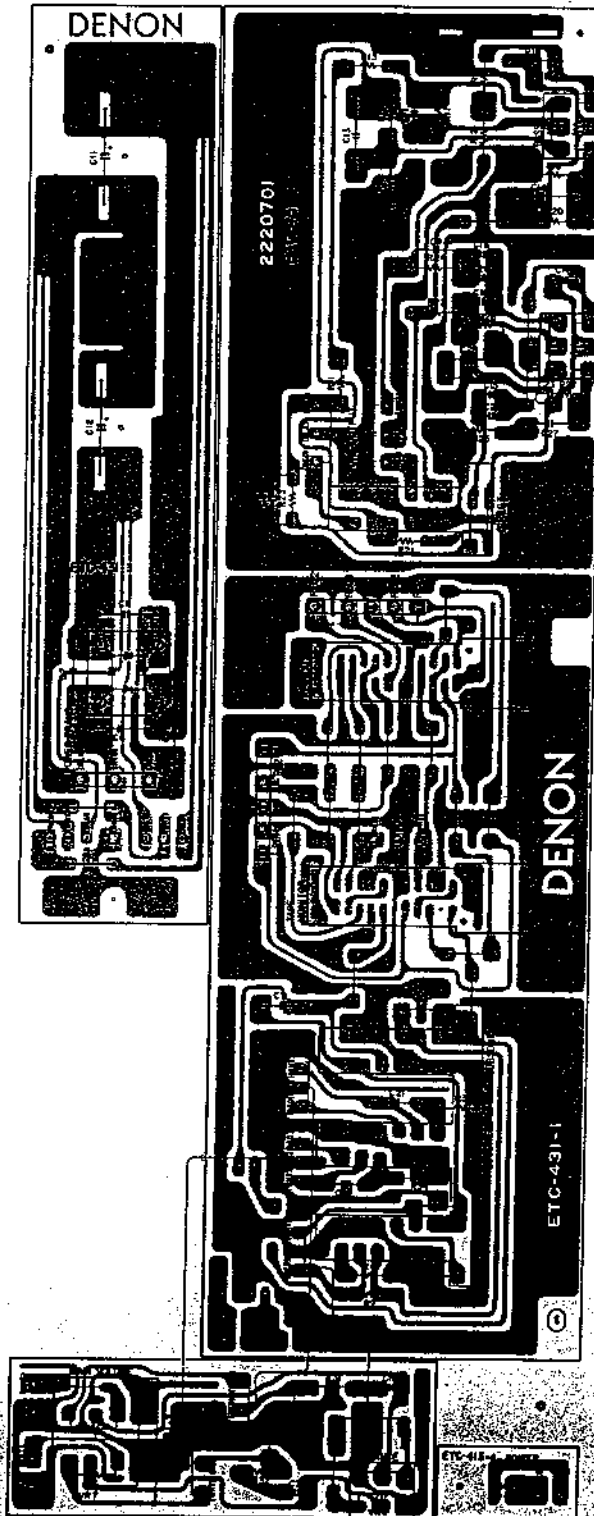

ETC-431B PARTS LIST

Ref. No.	Part No.	Part Name & Descriptions	Ref. No.	Part No.	Part Name & Descriptions
SEMICONDUCTORS			OTHER PARTS		
D04	3939032007	TLR206(RED) LIGHT EMITTING DIODE		2220701006	P.W. BOARD
D07	2760312007	S10VB20F DIODE		2090047903	0.6 JUMPER WIRE USED 23
RESISTORS				EP-5667H1	TERMINAL FOR WRAPPING PIN USED 1
VR03	2110278005	VARIABLE RESISTOR 100 k ohm (FOR BASS)		2050087039	3P. TERMINAL USED 1
VR05	2110277006	VARIABLE RESISTOR 50 k ohm (FOR TREBLE)		2050122059	5P. CONNECTOR PIN ASS.
VR06	2110256108	VARIABLE RESISTOR 100 k ohm (FOR BALANCE)	SW01	2124288007	1P. PUSH SWITCH FOR DIRECT
VR07	2110276007	VARIABLE RESISTOR 55 k ohm (FOR MAIN VR)	SW02	2120190005	ROTARY SWITCH (A) FOR REC OUT
R01	2412130003	39 k ohm ±5% 1/4W CARBON FILM	SW03	2120189003	ROTARY SWITCH (B) FOR MONITOR
R02	2412130003	39 k ohm ±5% 1/4W CARBON FILM	SW04	2124289006	3P. PUSH SWITCH FOR SUB. LOUD. MUT.
R03	2412108006	4.7 k ohm ±5% 1/4W CARBON FILM		2034147005	3P. CONNECTOR CORD FOR +B,E,-B
R04	2412108006	4.7 k ohm ±5% 1/4W CARBON FILM		2034149016	3P. CONNECTOR CORD FOR EQ OUT
R09	2420203003	10 M ohm ±10% 1/4W CARBON COMPOSIT		2034150021	3P. CONNECTOR CORD FOR TONE OUT (L)
R10	2420203003	10 M ohm ±10% 1/4W CARBON COMPOSIT		2034150034	3P. CONNECTOR CORD FOR TONE OUT (R)
R11	2412084007	470 ohm ±5% 1/4W CARBON FILM		2034156009	3P. CONNECTOR CORD FOR VOL OUT (L)
R12	2412084007	470 ohm ±5% 1/4W CARBON FILM		2034156012	3P. CONNECTOR CORD FOR VOL OUT (R)
R13	2412114003	8.2 k ohm ±5% 1/4W CARBON FILM		2034146019	3P. CONNECTOR CORD FOR POWER LED
R14	2412114003	8.2 k ohm ±5% 1/4W CARBON FILM		4140062001	SHIELD PLATE
R15	2412094000	1.2 k ohm ±5% 1/4W CARBON FILM			
R16	2412094000	1.2 k ohm ±5% 1/4W CARBON FILM			
R17	2412138005	82 k ohm ±5% 1/4W CARBON FILM			
R18	2412138005	82 k ohm ±5% 1/4W CARBON FILM			
R19	2412115002	9.1 k ohm ±5% 1/4W CARBON FILM			
R20	2412115002	9.1 k ohm ±5% 1/4W CARBON FILM			
R21	2412063002	62 ohm ±5% 1/4W CARBON FILM			
R22	2412063002	62 ohm ±5% 1/4W CARBON FILM			
R23	2412099005	2 k ohm ±5% 1/4W CARBON FILM			
R24	2412099005	2 k ohm ±5% 1/4W CARBON FILM			
R25	2412079009	300 ohm ±5% 1/4W CARBON FILM			
R26	2412079009	300 ohm ±5% 1/4W CARBON FILM			
R27	2412084007	470 ohm ±5% 1/4W CARBON FILM			
R28	2412084007	470 ohm ±5% 1/4W CARBON FILM			
R31	2412120000	15 k ohm ±5% 1/4W CARBON FILM			
R32	2412120000	15 k ohm ±5% 1/4W CARBON FILM			
R33	2412103001	3 k ohm ±5% 1/4W CARBON FILM			
R34	2412103001	3 k ohm ±5% 1/4W CARBON FILM			
CAPACITORS					
C03	2554127000	180pF ±5% 50V PLASTIC FILM			
C04	2554127000	180pF ±5% 50V PLASTIC FILM			
C05	2561016007	0.068μF ±10% 400V METALIZED			
C06	2561016007	0.068μF ±10% 400V METALIZED			
C07	2561016007	0.068μF ±10% 400V METALIZED			
C08	2561016007	0.068μF ±10% 400V METALIZED			
C09	2554082048	0.18μF ±5% 100V PLASTIC FILM			
C10	2554082048	0.18μF ±5% 100V PLASTIC FILM			
C11	2554183002	0.039μF ±5% 50V PLASTIC FILM			
C12	2554183002	0.039μF ±5% 50V PLASTIC FILM			
C13	2554082080	0.27μF ±5% 100V PLASTIC FILM			
C14	2554082080	0.27μF ±5% 100V PLASTIC FILM			
C15	2554161008	0.0047μF ±5% 50V PLASTIC FILM			
C16	2554161008	0.0047μF ±5% 50V PLASTIC FILM			
C17	2554127000	180pF ±5% 50V PLASTIC FILM			
C18	2554127000	180pF ±5% 50V PLASTIC FILM			
C19	2554142001	750pF ±5% 50V PLASTIC FILM			
C20	2554142001	750pF ±5% 50V PLASTIC FILM			
C21	2554193005	0.1μF ±5% 50V PLASTIC FILM			
C22	2554193005	0.1μF ±5% 50V PLASTIC FILM			
C23	2554147006	0.0012μF ±5% 50V PLASTIC FILM			
C24	2554147006	0.0012μF ±5% 50V PLASTIC FILM			
C25	2554155001	0.0027μF ±5% 50V PLASTIC FILM			
C26	2554155001	0.0027μF ±5% 50V PLASTIC FILM			
C27	2554187008	0.056μF ±5% 50V PLASTIC FILM			
C28	2554187008	0.056μF ±5% 50V PLASTIC FILM			

POWER AMP UNIT PUS-029

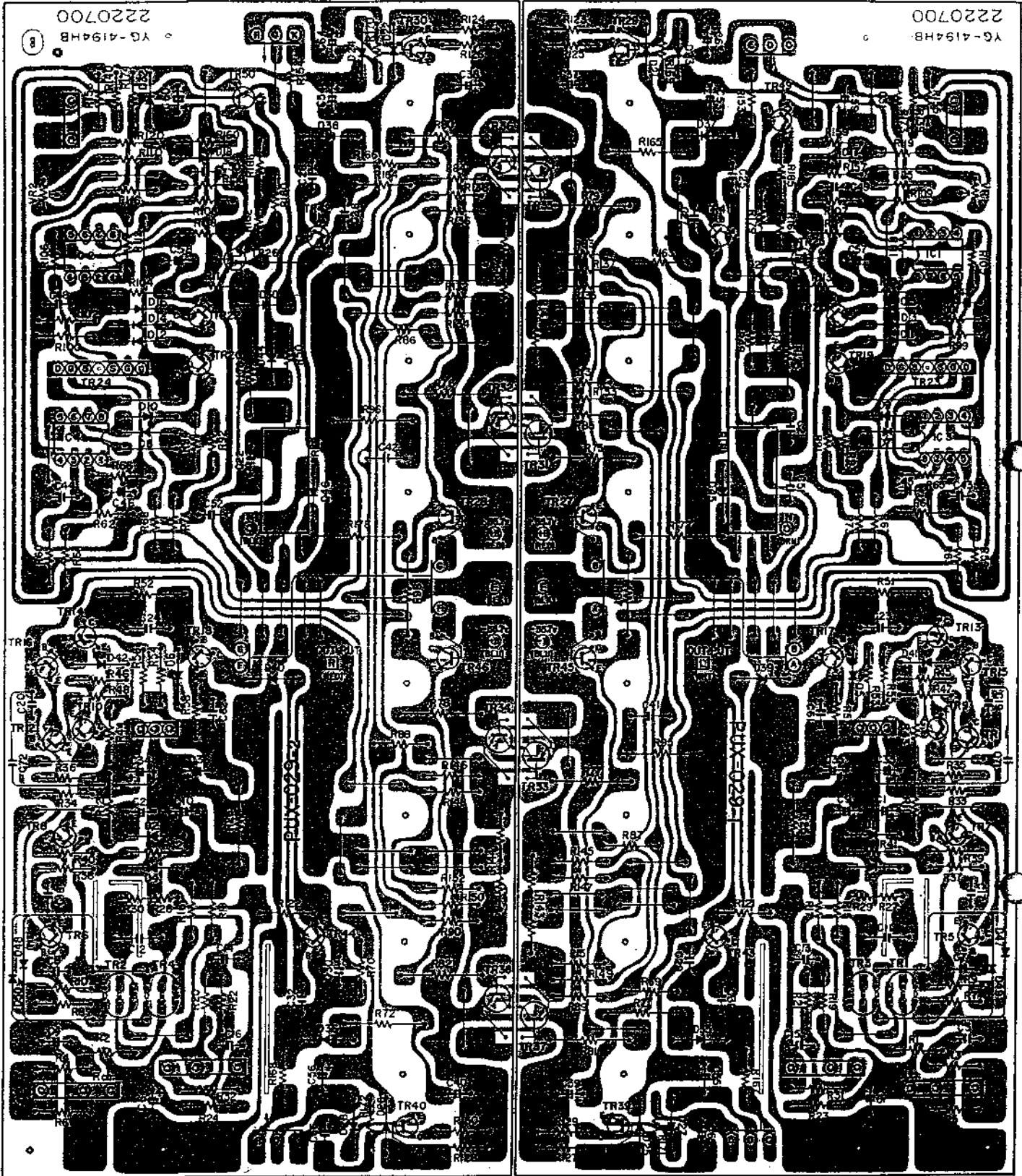

PUS-029 PARTS LIST

Ref. No.	Part No.	Part Name & Descriptions		Ref. No.	Part No.	Part Name & Descriptions	
SEMICONDUCTORS							
IC01	2630081002	NJM4558D	INTEGRATED CIRCUIT	D30	2760049011	1S2076A	DIODE
IC02	2630081002	NJM4558D	INTEGRATED CIRCUIT	D31	2760049008	1S2076	DIODE
IC03	2630081002	NJM4558D	INTEGRATED CIRCUIT	D32	2760049008	1S2076	DIODE
IC04	2630081002	NJM4558D	INTEGRATED CIRCUIT	D35	2760049011	1S2076A	DIODE
TR01	2750022035	2SK129A(K)/(L)	FIELD EFFECT TRANSISTOR	D36	2760049011	1S2076A	DIODE
TR02	2750022035	2SK129A(K)/(L)	FIELD EFFECT TRANSISTOR	D37	2760049011	1S2076A	DIODE
TR03	2750022035	2SK129A(K)/(L)	FIELD EFFECT TRANSISTOR	D38	2760049011	1S2076A	DIODE
TR04	2750022035	2SK129A(K)/(L)	FIELD EFFECT TRANSISTOR	D39	2760049011	1S2076A	DIODE
TR05	2730235020	2SC1841(F)/(E)	TRANSISTOR	D40	2760049011	1S2076A	DIODE
TR06	2730235020	2SC1841(F)/(E)	TRANSISTOR	D41	2760244007	MZ303A	DIODE
TR07	2730235020	2SC1841(F)/(E)	TRANSISTOR	D42	2760244007	MZ303A	DIODE
TR08	2730235020	2SC1841(F)/(E)	TRANSISTOR	D43	2760177006	MZ-306	DIODE
TR09	2710102005	2SA1015(Y)	TRANSISTOR	D44	2760177006	MZ-036	DIODE
TR10	2710102005	2SA1015(Y)	TRANSISTOR	D45	2760049011	1S2076A	DIODE
TR11	2710102005	2SA1015(Y)	TRANSISTOR	D46	2760049011	1S2076A	DIODE
TR12	2710102005	2SA1015(Y)	TRANSISTOR	D47	2760049008	1S2076	DIODE
TR13	2710110000	2SA916(L)	TRANSISTOR	D48	2760049008	1S2076	DIODE
TR14	2710110000	2SA916(L)	TRANSISTOR	D49	2760049008	1S2076	DIODE
TR15	2710110000	2SA916(L)	TRANSISTOR	D50	2760049008	1S2076	DIODE
TR16	2710110000	2SA916(L)	TRANSISTOR	RESISTORS			
TR17	2730205005	2SC1941(L)	TRANSISTOR	VR01	2116014043	SEMI FIXED RESISTOR 500 ohm	
TR18	2730205005	2SC1941(L)	TRANSISTOR	VR02	2116014043	SEMI FIXED RESISTOR 500 ohm	
TR19	2730198015	2SC1815(BL)	TRANSISTOR	RESISTORS			
TR20	2730198015	2SC1815(BL)	TRANSISTOR	R05	2412157002	510 k ohm ±5% ¼W	CARBON FILM
TR21	2730198015	2SC1815(BL)	TRANSISTOR	R06	2412157002	510 k ohm ±5% ¼W	CARBON FILM
TR22	2730198015	2SC1815(BL)	TRANSISTOR	R07	2412318029	4.7 k ohm ±2% ¼W	CARBON FILM
TR23	2750024059	µPA68H(M)/(N)	FIELD EFFECT TRANSISTOR	R08	2412318029	4.7 k ohm ±2% ¼W	CARBON FILM
TR24	2750024059	µPA68H(M)/(N)	FIELD EFFECT TRANSISTOR	R09	2412318029	4.7 k ohm ±2% ¼W	CARBON FILM
TR25	2750020024	2SK163(M)/(N)	FIELD EFFECT TRANSISTOR	R10	2412318029	4.7 k ohm ±2% ¼W	CARBON FILM
TR26	2750020024	2SK163(M)/(N)	FIELD EFFECT TRANSISTOR	R11	2442002020	7.5 k ohm ±5% 1W	METAL OXIDE FILM
TR27	2730199027	2SC2238(Y)/(O)	TRANSISTOR	R12	2442002020	7.5 k ohm ±5% 1W	METAL OXIDE FILM
TR28	2730199027	2SC2238(Y)/(O)	TRANSISTOR	R15	2412114003	8.2 k ohm ±5% ¼W	CARBON FILM
TR29	2740060007	2SD667A(C)	TRANSISTOR	R16	2412114003	8.2 k ohm ±5% ¼W	CARBON FILM
TR30	2740060007	2SD667A(C)	TRANSISTOR	R17	2412114003	8.2 k ohm ±5% ¼W	CARBON FILM
TR31	2730247021	2SC2921 LB(O)/(Y)	TRANSISTOR	R18	2412114003	8.2 k ohm ±5% ¼W	CARBON FILM
TR32	2730247021	2SC2921 LB(O)/(Y)	TRANSISTOR	RESISTORS			
TR33	2710145020	2SA1215LB(O)/(H)	TRANSISTOR	R21	2412111006	6.2 k ohm ±5% ¼W	CARBON FILM
TR34	2710145020	2SA1215LB(O)/(Y)	TRANSISTOR	R22	2412111006	6.2 k ohm ±5% ¼W	CARBON FILM
TR35	2730247021	2SC2921 LB(O)/(Y)	TRANSISTOR	R23	2412134009	56 k ohm ±5% ¼W	CARBON FILM
TR36	2730247021	2SC2921 LB(O)/(Y)	TRANSISTOR	R24	2412134009	56 k ohm ±5% ¼W	CARBON FILM
TR37	2710145020	2SA1215LB(O)/(Y)	TRANSISTOR	RESISTORS			
TR38	2710145020	2SA1215LB(O)/(Y)	TRANSISTOR	R27	2420203003	10 M ohm ±10% ¼W	CARBON COMPOSIT
TR39	2720053005	2S8647A(C)	TRANSISTOR	R28	2420203003	10 M ohm ±10% ¼W	CARBON COMPOSIT
TR40	2720053005	2S8647A(C)	TRANSISTOR	R29	2420203003	10 M ohm ±10% ¼W	CARBON COMPOSIT
TR41	2730198002	2SC1815(Y)	TRANSISTOR	R30	2420203003	10 M ohm ±10% ¼W	CARBON COMPOSIT
TR42	2730198002	2SC1815(Y)	TRANSISTOR	R31	2412130003	39 k ohm ±5% ¼W	CARBON COMPOSIT
TR43	2710102005	2SA1015(Y)	TRANSISTOR	R32	2412130003	39 k ohm ±5% ¼W	CARBON FILM
TR44	2710102005	2SA1015(Y)	TRANSISTOR	RESISTORS			
TR45	2710104029	2SA968(Y)/(O)	TRANSISTOR	R45	2412044005	10 ohm ±5% ¼W	CARBON FILM
TR46	2710104029	2SA968(Y)/(O)	TRANSISTOR	R46	2412044005	10 ohm ±5% ¼W	CARBON FILM
TR49	2710102005	2SA1015(Y)	TRANSISTOR	R47	2412044005	10 ohm ±5% ¼W	CARBON FILM
TR50	2710102005	2SA1015(Y)	TRANSISTOR	R48	2412044005	10 ohm ±5% ¼W	CARBON FILM
D01	2760219003	HZ-15	DIODE	RESISTORS			
D02	2760219003	HZ-15	DIODE	R45	2412044005	10 ohm ±5% ¼W	CARBON FILM
D03	2760219003	HZ-15	DIODE	R46	2412044005	10 ohm ±5% ¼W	CARBON FILM
D04	2760219003	HZ-15	DIODE	R47	2412044005	10 ohm ±5% ¼W	CARBON FILM
D05	2760171028	HV-23G(YL)	DIODE	R48	2412044005	10 ohm ±5% ¼W	CARBON FILM
D06	2760171028	HV-23G(YL)	DIODE	RESISTORS			
D07	2760049008	1S2076	DIODE	R45	2412044005	10 ohm ±5% ¼W	CARBON FILM
D08	2760049008	1S2076	DIODE	R46	2412044005	10 ohm ±5% ¼W	CARBON FILM
D09	2760049008	1S2076	DIODE	R47	2412044005	10 ohm ±5% ¼W	CARBON FILM
D10	2760049008	1S2076	DIODE	R48	2412044005	10 ohm ±5% ¼W	CARBON FILM
D11	2760049008	1S2076	DIODE	RESISTORS			
D12	2760049008	1S2076	DIODE	R45	2412044005	10 ohm ±5% ¼W	CARBON FILM
D13	2760049008	1S2076	DIODE	R46	2412044005	10 ohm ±5% ¼W	CARBON FILM
D14	2760049008	1S2076	DIODE	R47	2412044005	10 ohm ±5% ¼W	CARBON FILM
D15	2760216019	KB-265	DIODE	R48	2412044005	10 ohm ±5% ¼W	CARBON FILM
D16	2760216019	KB-265	DIODE	RESISTORS			
D17	2760049008	1S2076	DIODE	R45	2412044005	10 ohm ±5% ¼W	CARBON FILM
D18	2760049008	1S2076	DIODE	R46	2412044005	10 ohm ±5% ¼W	CARBON FILM
D21	2760254000	HZ-7B-3	DIODE	R47	2412044005	10 ohm ±5% ¼W	CARBON FILM
D22	2760254000	HZ-7B-3	DIODE	R48	2412044005	10 ohm ±5% ¼W	CARBON FILM
D23	2760049008	1S2076	DIODE	RESISTORS			
D24	2760049008	1S2076	DIODE	R45	2412044005	10 ohm ±5% ¼W	CARBON FILM
D25	2760254000	HZ7B-3	DIODE	R46	2412044005	10 ohm ±5% ¼W	CARBON FILM
D26	2760254000	HZ7B-3	DIODE	R47	2412044005	10 ohm ±5% ¼W	CARBON FILM
D27	2760049008	1S2076	DIODE	R48	2412044005	10 ohm ±5% ¼W	CARBON FILM
D28	2760049008	1S2076	DIODE	RESISTORS			
D29	2760049011	1S2076A	DIODE	R45	2412044005	10 ohm ±5% ¼W	CARBON FILM

(Con.)

Ref. No.	Part No.	Part Name & Descriptions
R59	241213002	43 k ohm ±5% 1/2W CARBON FILM
R60	241213002	43 k ohm ±5% 1/2W CARBON FILM
R61	2412121009	16 k ohm ±5% 1/2W CARBON FILM
R62	2412121009	16 k ohm ±5% 1/2W CARBON FILM
R63	2412131002	43 k ohm ±5% 1/2W CARBON FILM
R64	2412131002	43 k ohm ±5% 1/2W CARBON FILM
R65	2412121009	16 k ohm ±5% 1/2W CARBON FILM
R66	2412121009	16 k ohm ±5% 1/2W CARBON FILM
R67	2412113004	7.5 k ohm ±5% 1/2W CARBON FILM
R68	2412113004	7.5 k ohm ±5% 1/2W CARBON FILM
R69	2412261005	120 ohm ±2% 1/2W METAL OXIDE FILM
R70	2412261005	120 ohm ±2% 1/2W METAL OXIDE FILM
R71	2412261005	120 ohm ±2% 1/2W METAL OXIDE FILM
R72	2412261005	120 ohm ±2% 1/2W METAL OXIDE FILM
R73	2412112005	6.8 k ohm ±5% 1/2W CARBON FILM
R74	2412112005	6.8 k ohm ±5% 1/2W CARBON FILM
R75	2412261005	120 ohm ±2% 1/2W METAL OXIDE FILM
R76	2412261005	120 ohm ±2% 1/2W METAL OXIDE FILM
R77	2412261005	120 ohm ±2% 1/2W METAL OXIDE FILM
R78	2412261005	120 ohm ±2% 1/2W METAL OXIDE FILM
R79	2412261005	120 ohm ±2% 1/2W METAL OXIDE FILM
R80	2412261005	120 ohm ±2% 1/2W METAL OXIDE FILM
R81	2412128002	33 k ohm ±5% 1/2W METAL OXIDE FILM
R82	2412128002	33 k ohm ±5% 1/2W METAL OXIDE FILM
R83	2412128002	33 k ohm ±5% 1/2W METAL OXIDE FILM
R84	2412128002	33 k ohm ±5% 1/2W METAL OXIDE FILM
R85	2412261005	120 ohm ±2% 1/2W METAL OXIDE FILM
R86	2412261005	120 ohm ±2% 1/2W METAL OXIDE FILM
R87	2412261005	120 ohm ±2% 1/2W METAL OXIDE FILM
R88	2412261005	120 ohm ±2% 1/2W METAL OXIDE FILM
R89	2412261005	120 ohm ±2% 1/2W METAL OXIDE FILM
R90	2412261005	120 ohm ±2% 1/2W METAL OXIDE FILM
R91	2412155004	430 k ohm ±5% 1/2W CARBON FILM
R92	2412155004	430 k ohm ±5% 1/2W CARBON FILM
R93	2420195001	2.2 M ohm ±10% 1/2W CARBON COMPOSIT
R94	2420195001	2.2 M ohm ±10% 1/2W CARBON COMPOSIT
R95	2412155004	430 k ohm ±5% 1/2W CARBON FILM
R96	2412155004	430 k ohm ±5% 1/2W CARBON FILM
R97	2412155004	430 k ohm ±5% 1/2W CARBON FILM
R98	2412155004	430 k ohm ±5% 1/2W CARBON FILM
R99	2412155004	430 k ohm ±5% 1/2W CARBON FILM
R100	2412155004	430 k ohm ±5% 1/2W CARBON FILM
R101	2420195001	2.2 M ohm ±10% 1/2W CARBON COMPOSIT
R102	2420195001	2.2 M ohm ±10% 1/2W CARBON COMPOSIT
R103	2412164008	1 M ohm ±5% 1/2W CARBON FILM
R104	2412164008	1 M ohm ±5% 1/2W CARBON FILM
R105	2412112005	6.8 k ohm ±5% 1/2W CARBON FILM
R106	2412112005	6.8 k ohm ±5% 1/2W CARBON FILM
R107	2412128002	33 k ohm ±5% 1/2W CARBON FILM
R108	2412128002	33 k ohm ±5% 1/2W CARBON FILM
R109	2412112005	6.8 k ohm ±5% 1/2W CARBON FILM
R110	2412112005	6.8 k ohm ±5% 1/2W CARBON FILM
R111	2412112005	6.8 k ohm ±5% 1/2W CARBON FILM
R112	2412112005	6.8 k ohm ±5% 1/2W CARBON FILM
R113	2412132001	47 k ohm ±5% 1/2W CARBON FILM
R114	2412132001	47 k ohm ±5% 1/2W CARBON FILM
R115	2412108006	4.7 k ohm ±5% 1/2W CARBON FILM
R116	2412108006	4.7 k ohm ±5% 1/2W CARBON FILM
R117	2412110007	5.6 k ohm ±5% 1/2W CARBON FILM
R118	2412110007	5.6 k ohm ±5% 1/2W CARBON FILM
R119	2412088003	680 ohm ±5% 1/2W CARBON FILM
R120	2412088003	680 ohm ±5% 1/2W CARBON FILM

Ref. No.	Part No.	Part Name & Descriptions
R121	2412261005	120 ohm ±2% 1/2W METAL OXIDE FILM
R122	2412261005	120 ohm ±2% 1/2W METAL OXIDE FILM
R123	2412261005	120 ohm ±2% 1/2W METAL OXIDE FILM
R124	2412261005	120 ohm ±2% 1/2W METAL OXIDE FILM
R125	2412261005	120 ohm ±2% 1/2W METAL OXIDE FILM
R126	2412261005	120 ohm ±2% 1/2W METAL OXIDE FILM
R127	2412261005	120 ohm ±2% 1/2W METAL OXIDE FILM
R128	2412261005	120 ohm ±2% 1/2W METAL OXIDE FILM
R129	2412261005	120 ohm ±2% 1/2W METAL OXIDE FILM
R130	2412261005	120 ohm ±2% 1/2W METAL OXIDE FILM
R131	2412261005	120 ohm ±2% 1/2W METAL OXIDE FILM
R132	2412261005	120 ohm ±2% 1/2W METAL OXIDE FILM
R133	2412261005	120 ohm ±2% 1/2W METAL OXIDE FILM
R134	2412261005	120 ohm ±2% 1/2W METAL OXIDE FILM
R135	2412261005	120 ohm ±2% 1/2W METAL OXIDE FILM
R136	2412261005	120 ohm ±2% 1/2W METAL OXIDE FILM
R137	2412261005	120 ohm ±2% 1/2W METAL OXIDE FILM
R138	2412261005	120 ohm ±2% 1/2W METAL OXIDE FILM
R139	2412068007	100 ohm ±5% 1/2W CARBON FILM
R140	2412068007	100 ohm ±5% 1/2W CARBON FILM
R141	2432026029	1 ohm/1 ohm ±10% 3.15W WIRE WOUND
R142	2432026029	1 ohm/1 ohm ±10% 3.15W WIRE WOUND
R143	2432026029	1 ohm/1 ohm ±10% 3.15W WIRE WOUND
R144	2432026029	1 ohm/1 ohm ±10% 3.15W WIRE WOUND
R145	2412261005	120 ohm ±2% 1/2W METAL OXIDE FILM
R146	2412261005	120 ohm ±2% 1/2W METAL OXIDE FILM
R147	2412261005	120 ohm ±2% 1/2W METAL OXIDE FILM
R148	2412261005	120 ohm ±2% 1/2W METAL OXIDE FILM
R149	2412261005	120 ohm ±2% 1/2W METAL OXIDE FILM
R150	2412261005	120 ohm ±2% 1/2W METAL OXIDE FILM
R151	2412261005	120 ohm ±2% 1/2W METAL OXIDE FILM
R152	2412261005	120 ohm ±2% 1/2W METAL OXIDE FILM
R153	2412116001	10 k ohm ±5% 3.15W WIRE WOUND
R154	2412116001	10 k ohm ±5% 3.15W WIRE WOUND
R155	2412068007	100 ohm ±5% 1/2W CARBON FILM
R156	2412068007	100 ohm ±5% 1/2W CARBON FILM
R157	2412092002	1 k ohm ±5% 3.15W WIRE WOUND
R158	2412092002	1 k ohm ±5% 3.15W WIRE WOUND
R159	2412108006	4.7 k ohm ±5% 3.15W WIRE WOUND
R160	2412108006	4.7 k ohm ±5% 3.15W WIRE WOUND
R161	2790006011	100 ohm (112101-2)
R162	2790006011	100 ohm (112101-2)
R163	2412261005	120 ohm ±2% 1/2W METAL OXIDE FILM
R164	2412261005	120 ohm ±2% 1/2W METAL OXIDE FILM
R165	2412261005	120 ohm ±2% 1/2W METAL OXIDE FILM
R166	2412261005	120 ohm ±2% 1/2W METAL OXIDE FILM
R167	2412116001	10 k ohm ±5% 1/2W CARBON FILM
R168	2412116001	10 k ohm ±5% 1/2W CARBON FILM
R169	2412130003	39 k ohm ±5% 1/2W CARBON FILM
R170	2412130003	39 k ohm ±5% 1/2W CARBON FILM
R171	2412130003	39 k ohm ±5% 1/2W CARBON FILM
R172	2412130003	39 k ohm ±5% 1/2W CARBON FILM
R173	2412108006	4.7 k ohm ±5% 1/2W CARBON FILM
R174	2412108006	4.7 k ohm ±5% 1/2W CARBON FILM
R175	2440037026	470 ohm ±5% 1W METAL OXIDE FILM
R176	2440037026	470 ohm ±5% 1W METAL OXIDE FILM
R177	2440044022	1.8 k ohm ±5% 1W METAL OXIDE FILM
R178	2440044022	1.8 k ohm ±5% 1W METAL OXIDE FILM

(Con.)

Ref. No.	Part No.	Part Name & Descriptions		Ref. No.	Part No.	Part Name & Descriptions	
CAPACITORS				C46	2521014007	15pF	±5% 50V MICA FILM
C01	2544015009	10μF	16V ELECTROLYTIC	C47	2554161008	0.0047μF	±5% 50V PLASTIC FILM
C02	2544015009	10μF	16V ELECTROLYTIC	C48	2554161008	0.0047μF	±5% 50V PLASTIC FILM
C03	2521034003	100pF	±5% 50V MICA FILM	C49	2554121006	100pF	±5% 50V PLASTIC FILM
C04	2521034003	100pF	±5% 50V MICA FILM	C50	2554121006	100pF	±5% 50V PLASTIC FILM
C05	2544044009	1μF	50V ELECTROLYTIC	C51	2554131009	270pF	±5% 50V PLASTIC FILM
C06	2544044009	1μF	50V ELECTROLYTIC	C52	2554131009	270pF	±5% 50V PLASTIC FILM
C07	2554149004	0.0015μF	±5% 50V PLASTIC FILM	C53	2544004007	220μF	6.3V ELECTROLYTIC
C08	2554149004	0.0015μF	±5% 50V PLASTIC FILM	C54	2544004007	220μF	6.3V ELECTROLYTIC
C09	2544015009	10μF	16V ELECTROLYTIC	C55	2544004007	220μF	6.3V ELECTROLYTIC
C10	2544015009	10μF	16V ELECTROLYTIC	C56	2544004007	220μF	6.3V ELECTROLYTIC
C11	2561026000	1μF	±10% 125V METALIZED FILM	C57	2544044009	1μF	50V ELECTROLYTIC
C12	2561026000	1μF	±10% 125V METALIZED FILM	C58	2544044009	1μF	50V ELECTROLYTIC
C13	2521008000	8pF	±0.5pF 50V MICA FILM	C59	2544044009	1μF	50V ELECTROLYTIC
C14	2521008000	8pF	±0.5pF 50V MICA FILM	C60	2544044009	1μF	50V ELECTROLYTIC
C15	2521016005	18pF	±5% 50V MICA FILM	C61	2554131009	270pF	±5% 50V PLASTIC FILM
C16	2521016005	18pF	±5% 50V MICA FILM	C62	2554131009	270pF	±5% 50V PLASTIC FILM
C17	2521026008	47pF	±5% 50V MICA FILM	C63	2544060025	1μF	100V ELECTROLYTIC
C18	2521026008	47pF	±5% 50V MICA FILM	C64	2544060025	1μF	100V ELECTROLYTIC
C19	2521081030	5pF	±0.5pF 500V MICA FILM	C65	2544060025	1μF	100V ELECTROLYTIC
C20	2521081030	5pF	±0.5pF 500V MICA FILM	C66	2544060025	1μF	100V ELECTROLYTIC
C21	2554145008	0.001μF	±5% 50V PLASTIC FILM	C71	2521034003	100pF	±5% 50V MICA FILM
C22	2554145008	0.001μF	±5% 50V PLASTIC FILM	C72	2521034003	100pF	±5% 50V MICA FILM
C23	2554084017	0.01μF	±5% 100V PLASTIC FILM	OTHER PARTS			
C24	2554084017	0.01μF	±5% 100V PLASTIC FILM		2220700007	P.W. BOARD	
C25	2554161008	0.0047μF	±5% 50V PLASTIC FILM		2090047903	0.6 JUMPER WIRE SHORTLEAD USED 74	
C26	2554161008	0.0047μF	±5% 50V PLASTIC FILM		EP-5667H1	TERMINAL FOR WRAPPING PIN USED 2	
C27	2554161008	0.0047μF	±5% 50V PLASTIC FILM		EP-6071	BASE PIN USED 6	
C28	2554161008	0.0047μF	±5% 50V PLASTIC FILM		2035622008	3P. CONNECTOR BASE USED 2	
C29	2554161008	0.0047μF	±5% 50V PLASTIC FILM	RL01	2050122033	3P. CONNECTOR PIN ASS. USED 4	
C30	2554161008	0.0047μF	±5% 50V PLASTIC FILM	RL02	2050075025	2P TERMINAL USED 2	
C31	2554161008	0.0047μF	±5% 50V PLASTIC FILM		2140029004	REED RELAY	
C32	2554161008	0.0047μF	±5% 50V PLASTIC FILM		2140029004	REED RELAY	
C33	2544059081	10μF	63V ELECTROLYTIC		2030223017	1P. CONNECTOR CORD FOR L	
C34	2544059081	10μF	63V ELECTROLYTIC		2030223020	1P. CONNECTOR CORD FOR R	
C35	2544059081	10μF	63V ELECTROLYTIC		4450033005	WIRE CLAMP BAND USED 4	
C36	2544059081	10μF	63V ELECTROLYTIC		4170139001	POWER RADIATOR USED 2	
C37	2544060025	1μF	100V ELECTROLYTIC		4700012022	CROSS PAN SCREW WITH S. WASHER 3x12 USED 16	
C38	2544060025	1μF	100V ELECTROLYTIC		4120871005	RADIATOR BRACKET (A) USED 2	
C39	2544060025	1μF	100V ELECTROLYTIC		4120872004	RADIATOR BRACKET (B) USED 2	
C40	2544060025	1μF	100V ELECTROLYTIC		4120873003	BRACKET (A) USED 2	
C41	2561017019	0.01μF	±10% 630V METALIZED FILM		4120874002	BRACKET (B) USED 2	
C42	2561017019	0.01μF	±10% 630V METALIZED FILM		4730354035	TAPPING SCREW (2)3x8 USED 16	
C43	2521014007	15pF	±5% 50V MICA FILM				
C44	2521014007	15pF	±5% 50V MICA FILM				
C45	2521014007	15pF	±5% 50V MICA FILM				

POWER SUPPLY & PROTECTOR UNIT ETC-432

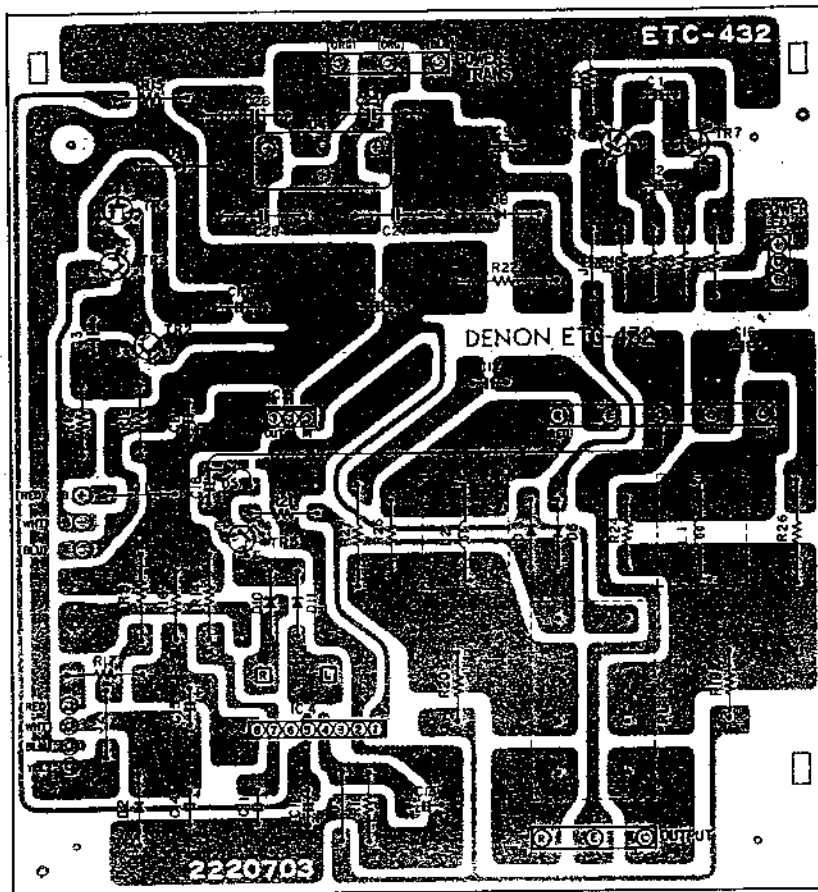

Ref. No.	Part No.	Part Name & Descriptions		Ref. No.	Part No.	Part Name & Descriptions	
SEMICONDUCTORS							
IC03	2630155006	μPC78M15	INTEGRATED CIRCUIT	R22	2440013024	4.7 ohm ±5% 1W	METAL OXIDE FILM
IC04	2630102004	HA12002W	INTEGRATED CIRCUIT	R24	2412060005	47 ohm ±5% ¼W	CARBON FILM
TR02	2710102005	2SA1015(Y)	TRANSISTOR	R25	2412060005	47 ohm ±5% ¼W	CARBON FILM
TR03	2710105002	2SA966(Y)	TRANSISTOR	R26	2440017020	10 ohm ±5% 1W	METAL OXIDE FILM
TR04	2750018023	2SK30A(R)/(O)	FIELD EFFECT TRANSISTOR	R27	2440017020	10 ohm ±5% 1W	METAL OXIDE FILM
TR05	2730235004	2SC1841(F)	TRANSISTOR	CAPACITORS			
TR07	2730198031	2SC1815(BL)/(GR)	TRANSISTOR	C01	2544024003	4.7μF	25V ELECTROLYTIC
TR08	2730198031	2SC1815(BL)/(GR)	TRANSISTOR	C02	2544024003	4.7μF	25V ELECTROLYTIC
D01	2760237001	RV06	DIODE	C03	2521018003	22pF ±5%	50V MICA FILM
D02	2760244007	MZ303A	DIODE	C04	2544079016	2200μF	25V ELECTROLYTIC
D03	2760237001	RV06	DIODE	C08	2544015009	10μF	16V ELECTROLYTIC
D04	2760239009	S1RBA20F	DIODE	C09	2544038002	100μF	35V ELECTROLYTIC
D05	2760244007	MZ303A	DIODE	C10	2544039001	220μF	35V ELECTROLYTIC
D06	2760049008	1S2076	DIODE	C11	2544044009	1μF	50V ELECTROLYTIC
D08	2760237001	RV06	DIODE	C12	2544066003	2.2μF	50V ELECTROLYTIC
D10	2760049011	1S2076A	DIODE	C13	2544005006	330μF	6.3V ELECTROLYTIC
D11	2760049011	1S2076A	DIODE	C14	2544003008	100μF	6.3V ELECTROLYTIC
RESISTORS							
R01	2410185005	1 k ohm ±5%	¼W CARBON FILM	C15	2549015004	2.2μF ±10%	10V ELECTROLYTIC
R02	2412152007	330 k ohm ±5%	¼W CARBON FILM	C16	2561017035	0.022μF ±10%	630V METALIZED
R03	2412152007	330 k ohm ±5%	¼W CARBON FILM	C17	2561017035	0.022μF ±10%	630V METALIZED
R04	2412126004	27 k ohm ±5%	¼W CARBON FILM	C18	2544009002	47μF	10V ELECTROLYTIC
R05	2412084007	470 ohm ±5%	¼W CARBON FILM	C25	2561016007	0.068μF ±10%	400V METALIZED
R08	2410179008	560 ohm ±5%	¼W CARBON FILM	C26	2561016007	0.068μF ±10%	400V METALIZED
R09	2412116001	10 k ohm ±5%	¼W CARBON FILM	C27	2561016007	0.068μF ±10%	400V METALIZED
R10	2412116001	10 k ohm ±5%	¼W CARBON FILM	C28	2561016007	0.068μF ±10%	400V METALIZED
R12	2412120000	15 k ohm ±5%	¼W CARBON FILM	OTHER PARTS			
R13	2412120000	15 k ohm ±5%	¼W CARBON FILM	L01	2220703004	P.W. BOARD	
R14	2410175002	390 ohm ±5%	¼W CARBON FILM	L02	2090008120	JUMPER SHORTLEAD P=10mm USED 4	
R15	2412108006	4.7 k ohm ±5%	¼W CARBON FILM	RL01	EP-6071	BASE PIN USED 2	
R16	2412163009	910 k ohm ±5%	¼W CARBON FILM		2050087039	3P. TERMINAL USED 2	
R17	2412044006	10 ohm ±5%	¼W CARBON FILM		2050087055	5P. TERMINAL USED 1	
R18	2412116001	10 k ohm ±5%	¼W CARBON FILM		2035622008	3P. CONNECTOR CORD (FOR +B, -B, E)	
R19	2412129001	36 k ohm ±5%	¼W CARBON FILM		2036082003	4P. CONNECTOR CORD (FOR MUT, LED)	
R20	2412129001	36 k ohm ±5%	¼W CARBON FILM		2320017001	INDUCTOR	
R21	2412108006	4.7 k ohm ±5%	¼W CARBON FILM		2320017001	INDUCTOR	
					2140041008	RELAY	
					4170043100	RADIATOR	
					4730354019	TAPPING SCREW (2)3x8	

WIRING DIAGRAM

⚠ Means important safety item, which must be replaced, when necessary, by a part specified or meeting the specification by the manufacturer.

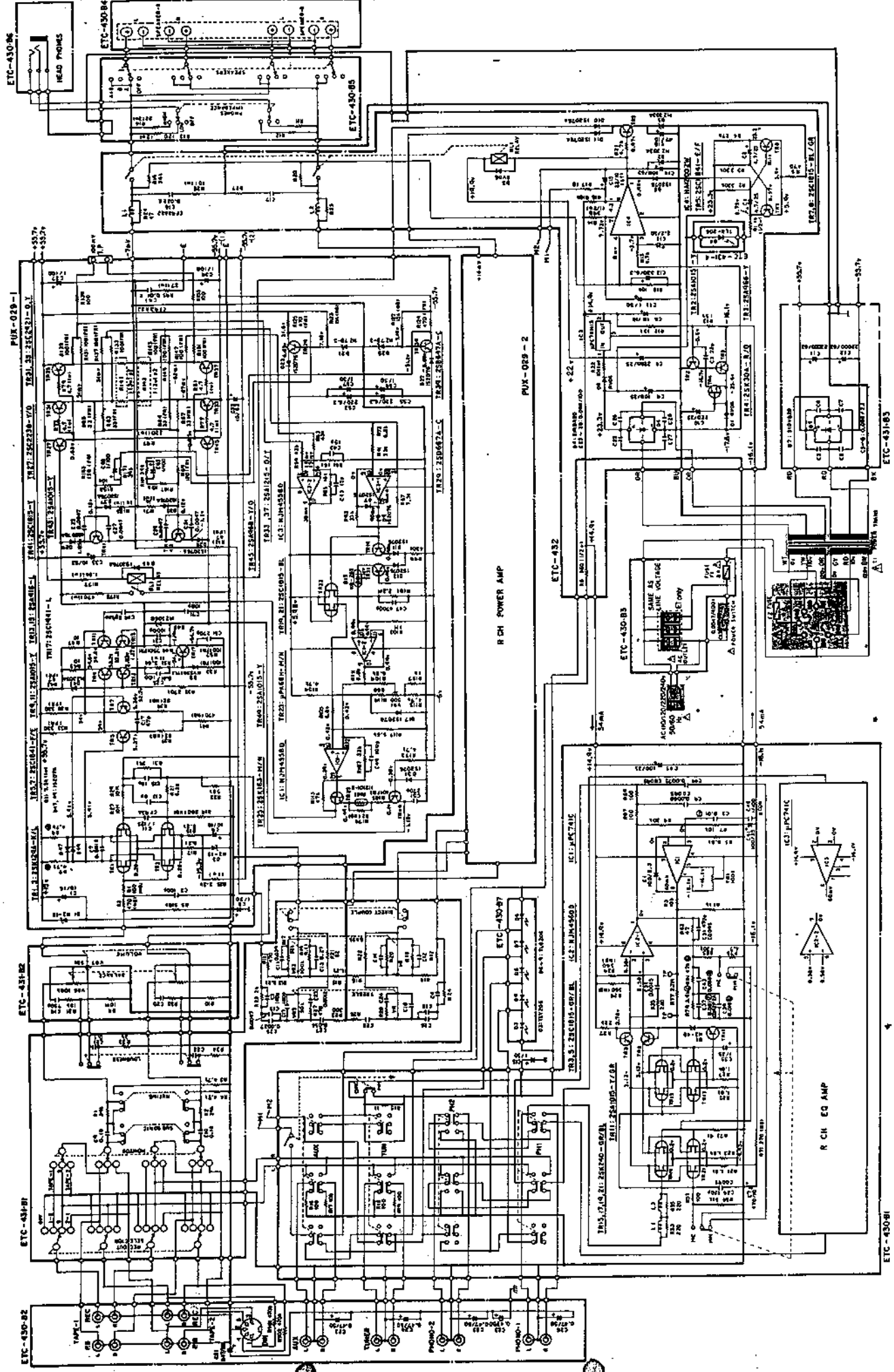

ETC-430-82
ETC-430-84
ETC-430-85
ETC-430-86
ETC-430-87
ETC-430-88
ETC-430-89
ETC-430-90
ETC-430-91

DENON

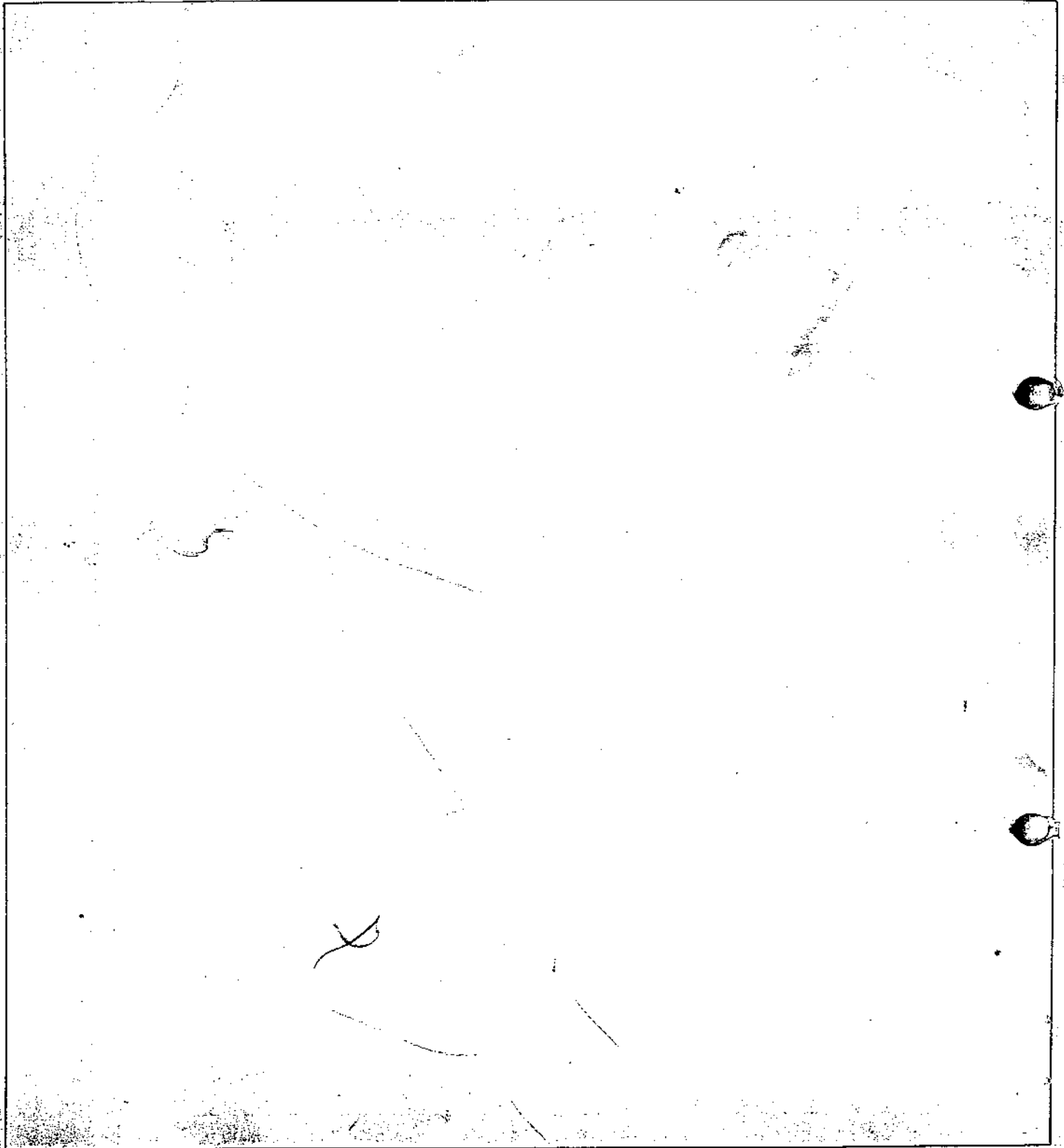

NIPPON COLUMBIA CO., LTD.
No. 14-14, 4-CHOME AKASAKA
MINATO-KU, TOKYO 107, JAPAN
TEL: 03-584-8111
TLX: JAPANOLA J22591
CABLE: NIPPONCOLUMBIA TOKYO