

DENON

Hi-Fi Integrated Amplifier

SERVICE MANUAL MODEL PMA-900V

SOLID STATE
INTEGRATED AMPLIFIER

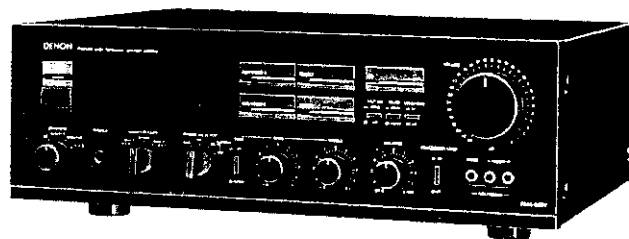

Outside U.S.A. Version

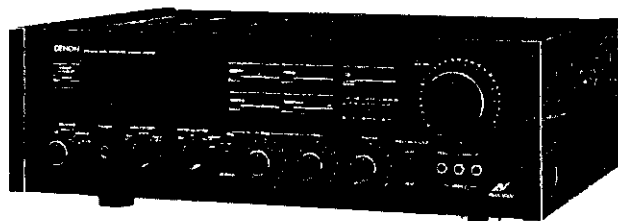

U.S.A. Version

TABLE OF CONTENTS

SPECIFICATIONS	2
NAMES AND FUNCTIONS OF PARTS	3
REMOVAL OF EACH SECTION	4
CONNECTIONS	5
BLOCK DIAGRAM	7
METHOD OF ADJUSTMENTS	7
SEMICONDUCTORS	8
PRINTED WIRING BOARD PATTERNS AND PARTS LIST	
ETC9053K EQ. & P.S UNIT	9
ETC9052K INPUT & POWER UNIT	10
WIRING DIAGRAM	14
SCHEMATIC DIAGRAM	17
EXPLODED VIEW OF CHASSIS AND CABINET & PARTS LIST	18

NIPPON COLUMBIA CO., LTD.

SPECIFICATIONS

POWER AMPLIFIER SECTION

Rated Output Power: Both channel drives (TUNER → SP OUT)
120 Watts minimum rms per channel (8 ohm Load) with less than 0.02% total harmonic distortion from 20 Hz to 20 kHz.
1 kHz (4 ohm Load) 200 W + 200 W (DIN, T.H.D 1%)
1 kHz (6 ohm Load) 90 W + 90 W (IEC, Subject to change by temperature test)

Total Harmonic Distortion: 0.003% (20 Hz – 20 kHz at –3 dB rated output 8 ohm Load)
0.002% (1 kHz at rated output 8 ohm Load)

Input Sensitivity: 150 mV

Input Impedance: 30 k ohm

MC 77 dB (input terminals short-circuited for 500 μV input)

TUNER/AUX, CD, TAPE, VIDEO-1, VIDEO-2

107 dB (input terminals short-circuited)

Tone Control Adjustable

Range:

BASS 100 Hz ±10 dB
TREBLE 10 kHz ±10 dB
SUBSONIC 16 Hz, 12 dB/oct
Low frequency 100 Hz + 7 dB
High frequency 10 kHz + 6 dB

Filtering Characteristics:

Loudness Characteristics:

AC OUTLET:

(For U.S.A., Canada and Asia)

SWITCHED x 2, 100 W (Total)
UNSWITCHED x 1, 250 W

POWER SOURCE:

Germany and France AC 220 V, 50 Hz; U.K. and Australia AC 240 V, 50 Hz; U.S.A. and Canada AC 120 V, 60 Hz; Asia 110/120/220/240 V, 50/60 Hz (Multiple)

POWER CONSUMPTION:

4.5 A (U.S.A. & Canada); 250 W (IEC), 210 W (Multiple)

DIMENSIONS:

465 mm (18-5/16")W x 157 mm (6-3/16")H x 397 mm (15-5/8")D (For U.S.A. model only)
434 mm (17-5/64")W x 157 mm (6-3/16")H x 397 mm (15-5/8")D (For Europe, Multiple and Australia Version) (including rubber feet, control knobs, and terminals.)

WEIGHT:
11.6 kg (25 lbs 10 oz) (For U.S.A. model only)
10.6 kg (23 lbs 6 oz) (For Europe, Multiple and Australia Version)

EQUALIZER AMPLIFIER SECTION

Equalizer Amplifier Output: (REC OUT Terminal) Rated Output: 150 mV

Input Sensitivity/Input Impedance:

PHONO MM	2.5 mV	47 k ohm
MC	200 μV	100 ohm

CD, VIDEO-1, VIDEO-2, TUNER/AUX, TAPE

	150 mV	30 k ohm
--	--------	----------

RIAA Deviation:

PHONO MM	within ±0.2 dB (20 Hz – 20 kHz)
MC	within ±0.3 dB (20 Hz – 100 kHz)

Maximum Input Voltage:

PHONO MM	160 mV/1 kHz
MC	12 mV/1 kHz

OVERALL CHARACTERISTICS

SN Ratio (IHFA Network): PHONO MM 95 dB (input terminals short-circuited for 5 mV input)

Design and specifications are subject to change without prior notice.

NOTE: The following codes correspond to the appropriate models.
E3 for U.S.A., EA for Australia, EC for Canada
This Service Manual is prepared based on E2 for Black Version.

For United Kingdom model only.

WARNING:

As the colours of the wires in the mains lead of this appliance may not correspond with the coloured markings identifying the terminals in your plug proceed as follows:

The wire which is coloured blue must be connected to the terminal which is marked with the letter N or coloured black.

The wire which is coloured brown must be connected to the terminal which is marked with the letter L or coloured red.

The wire which is coloured BROWN must be connected to the terminal which is marked with the letter L or coloured RED.

IMPORTANT

The wires in this mains lead are coloured in accordance with the following code:

Blue: Neutral
Brown: Live

For Australia model only.

FOR YOUR SAFETY

To ensure safe operation the three-pin plug supplied must be inserted only into a standard three-pin power point which is effectively earthed through the normal household wiring.

Extension cords used with the equipment must be three-core and be correctly wired to provide connection to earth. Wrongly wired extension cords are a major cause of fatalities.

The fact that the equipment operates satisfactorily does not imply that the power point is earthed and that the installation is completely safe. For your safety, if in any doubt about the effective earthing of the power point, consult a qualified electrician.

For U.S.A. and Canada models.

CAUTION

TO PREVENT ELECTRIC SHOCK DO NOT USE THIS (POLARIZED) PLUG WITH AN EXTENSION CORD, RECEPTACLE OR OTHER OUTLET UNLESS THE BLADES CAN BE FULLY INSERTED TO PREVENT BLADE EXPOSURE.

NAMES AND FUNCTIONS OF PARTS

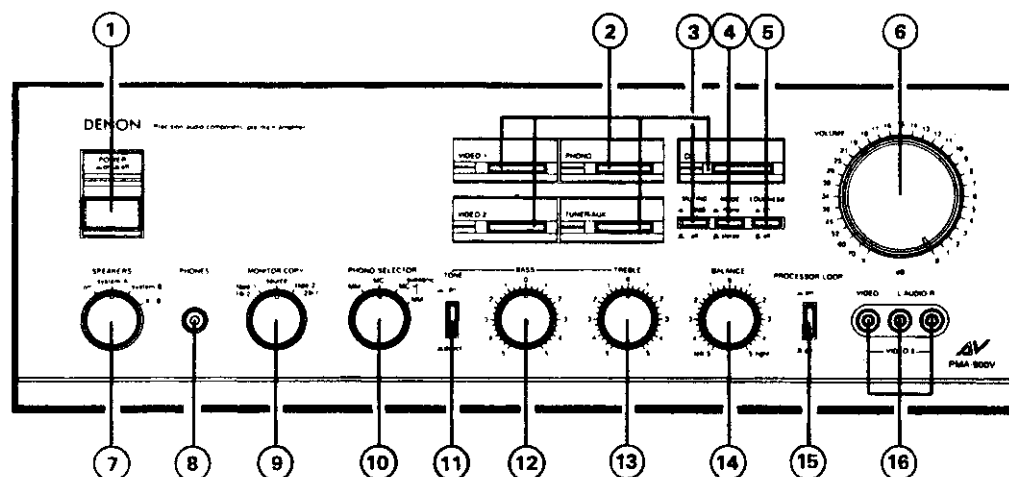

Fig. 1

- | | |
|--|---|
| <p>① POWER and LED indicator
(Power supply button and LED indicator)</p> <p>② INPUT SELECTOR (Input signal selection button)
● CD, ● PHONO, ● TUNER/AUX., ● VIDEO-1,
VIDEO-2</p> <p>③ MUTING (Muting button)</p> <p>④ MODE (Mode button)
● Stereo, ● Mono</p> <p>⑤ LOUDNESS (Loudness button)</p> <p>⑥ VOLUME (Adjustment of the volume)</p> <p>⑦ SPEAKERS (Speaker selection switch)
● system-A, ● system-B, ● A+B, ● off</p> | <p>⑧ PHONES (Headphone Jack)</p> <p>⑨ MONITOR COPY (Tape monitor/Copy switch)</p> <p>⑩ PHONO SELECTOR (Cartridge selection/Subsonic filter switch)</p> <p>⑪ TONE (Tone switch)</p> <p>⑫ BASS (Regulation of low notes)</p> <p>⑬ TREBLE (Regulation of high notes)</p> <p>⑭ BALANCE (Balance adjustment)</p> <p>⑮ PROCESSOR LOOP (Processor loop switch)</p> <p>⑯ FRONT VIDEO-2 (Extra front panel input terminal)</p> |
|--|---|

Video Input Function

The PMA-900V provides a video input function. The image selection circuitry gives preference to VIDEO-1 for all settings of the INPUT SELECTOR button, unless VIDEO-2 has been specified. This function might be used, for example, to watch a TV monitor while playing a compact disc. In this case it would connect the image input circuitry of the VIDEO-1 terminal to the image output of a video recorder, tape recorder, or video disc recorder. The resultant monitor out signal would be sent to the TV monitor, for "background video" audio-visual entertainment combining sound and images.

Note:

Please note the following differences in the markings on the front and back panels on the European models:

VIDEO-1 → AUX/VIDEO 1
 VIDEO-2 → AUX/VIDEO 2
 TUNER/AUX → TUNER

In addition, there is no AV mark on the front panel.

• Connecting a video device

Connect the output terminals of the video device (OUTPUT) to the VIDEO terminals of the amp, using a pin plug cord.

• CONNECTING A VIDEO DEVICE

< Video Disc Player >

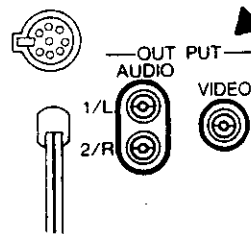
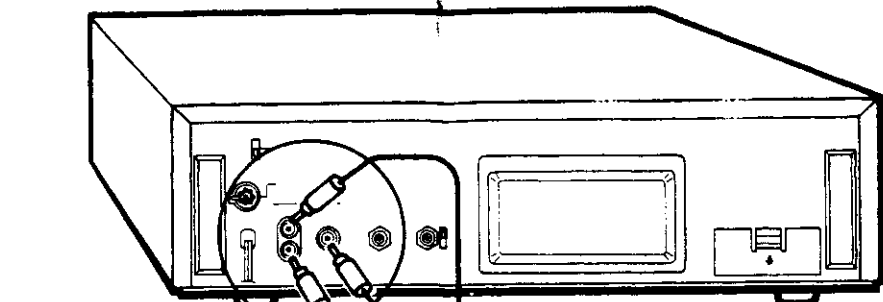

CONNECTING A VIDEO DISC PLAYER

(Ex.) Connect the video disc player to the VIDEO-1 terminal.
Video disc player terminals → PMA-900V terminals
VIDEO OUT (image) → VIDEO-1, VIDEO INPUT
AUDIO OUT (sound) → VIDEO-1, AUDIO INPUT

< VCR >

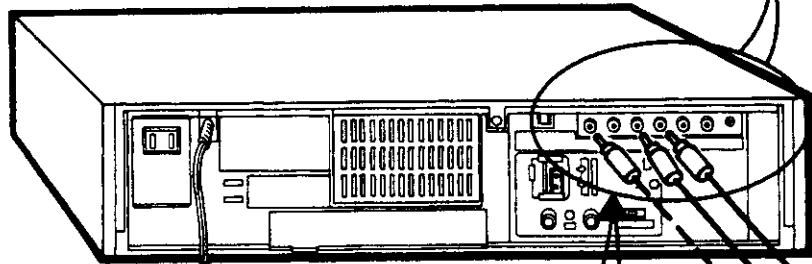

CONNECTING VCR

VCR terminals → PMA-900V terminals
VIDEO OUT (image) → VIDEO-2, VIDEO INPUT
AUDIO OUT (sound) → VIDEO-2, AUDIO INPUT
(Ex.) Connect the VCR to the VIDEO-2 terminal

< TV (must have image input terminal) >

TV TERMINALS → PMA-900V TERMINALS
Video image output terminal ← MONITOR OUT

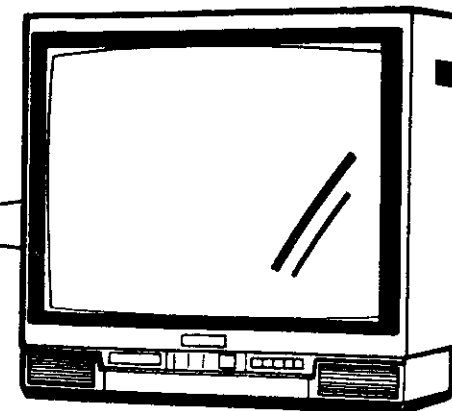

VIDEO INPUT

The PMA-900V has a VIDEO selection function. VIDEO-1 is automatically used for all playback functions, unless the input selection switch is set to VIDEO-2.

Connect the image output of a video device such as a VCR to VIDEO-1 for simultaneous playback with another medium, such as a compact disc.

CAUTION
SPEAKER IMPEDANCE
A or B 8Ω
A + B 12Ω

CAUTION
RISK OF ELECTRIC SHOCK
DO NOT OPEN
WARNING: TO PREVENT FIRE OR SHOCK HAZARD,
DO NOT EXPOSE THIS APPLIANCE TO RAIN OR
MOISTURE.

DENON
MODEL NO. PMA-900V
POWER SOURCE 120V - 60Hz
POWER CONSUMPTION
SERIAL NO. _____
DENON COLUMBIA CO. LTD.

Note:

The VIDEO-2 terminal is connected in parallel with a terminal on the front side of the panel. Either this terminal or the one on the front panel can be used to make the connection. Improper operation will result if both are connected and used at the same time.

Fig. 6

CONNECTIONS

CONNECTIONS

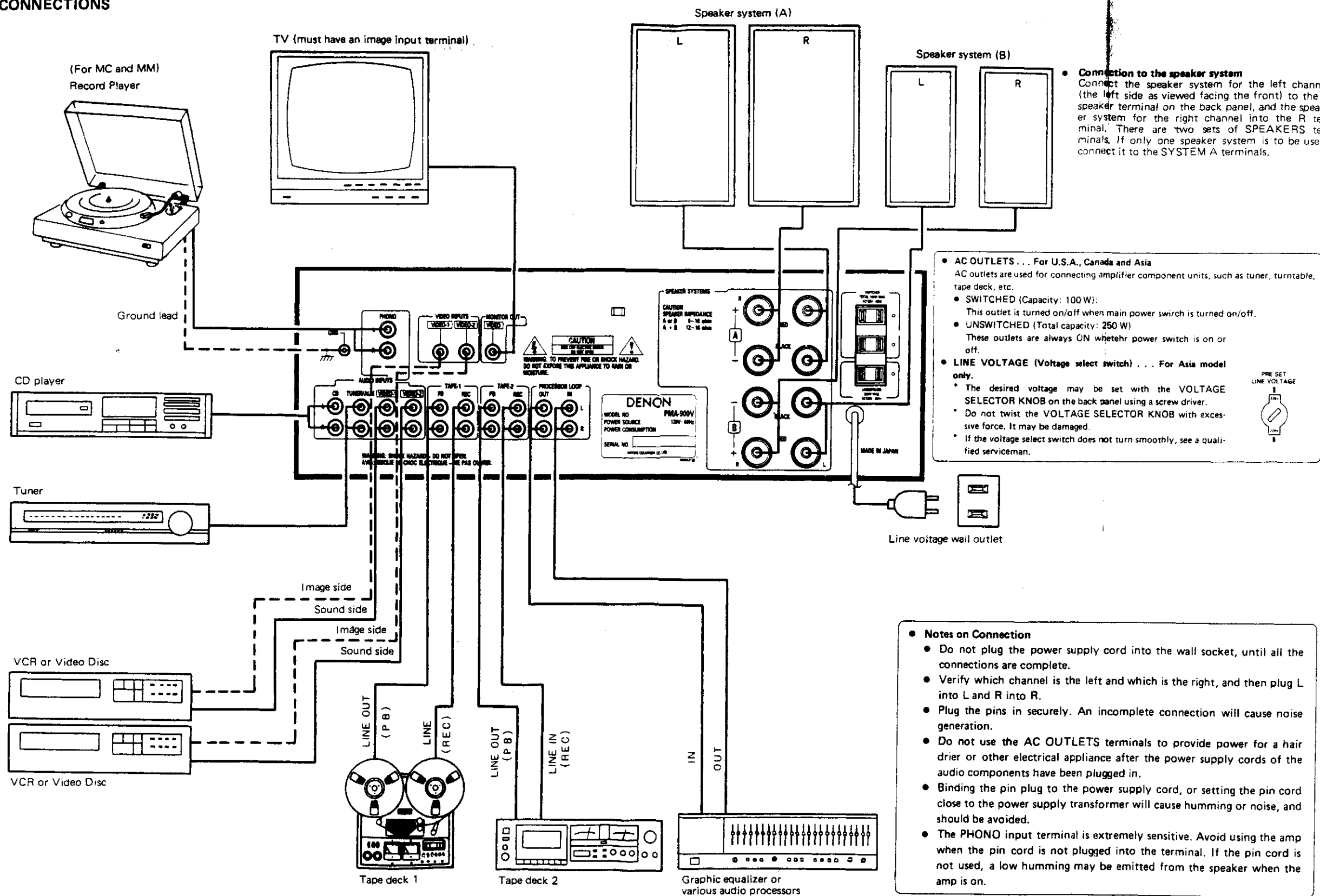

Fig. 5

• Connecting a video device

Connect the output terminals of the video device (OUTPUT) to the VIDEO terminals of the amp, using a pin plug cord.

• CONNECTING A VIDEO DEVICE

< Video Disc Player >

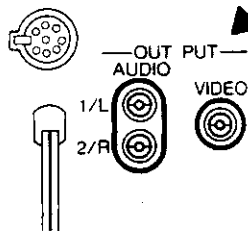
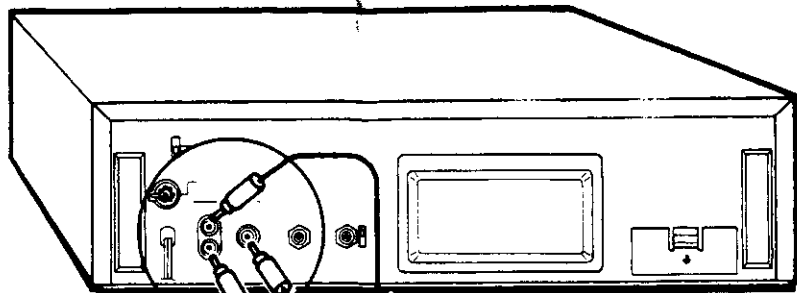

CONNECTING A VIDEO DISC PLAYER

(Ex.) Connect the video disc player to the VIDEO-1 terminal.
Video disc player terminals → PMA-900V terminals
VIDEO OUT (image) → VIDEO-1, VIDEO INPUT
AUDIO OUT (sound) → VIDEO-1, AUDIO INPUT

< VCR >

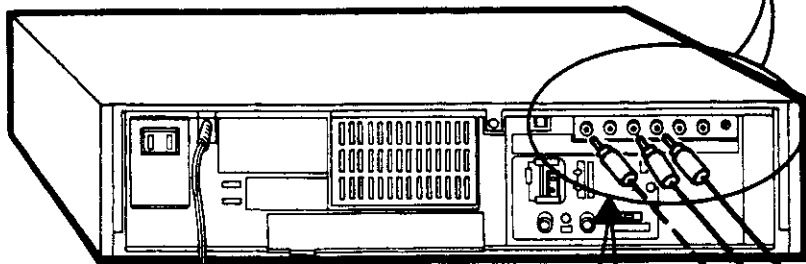

CONNECTING VCR

VCR terminals → PMA-900V terminals
VIDEO OUT (image) → VIDEO-2, VIDEO INPUT
AUDIO OUT (sound) → VIDEO-2, AUDIO INPUT
(Ex.) Connect the VCR to the VIDEO-2 terminal

< TV (must have image input terminal) >

TV TERMINALS → PMA-900V TERMINALS
Video image output terminal ← MONITOR OUT

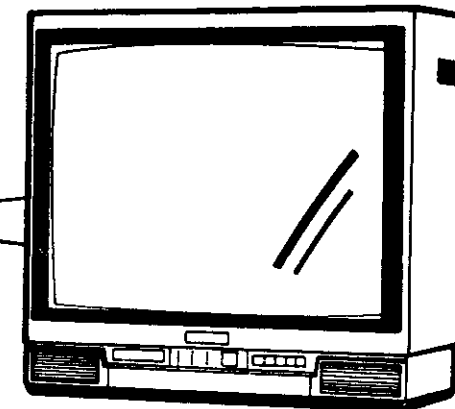

VIDEO INPUT

The PMA-900V has a VIDEO selection function. VIDEO-1 is automatically used for all playback functions, unless the input selection switch is set to VIDEO-2.

Connect the image output of a video device such as a VCR to VIDEO-1 for simultaneous playback with another medium, such as a compact disc.

CAUTION
SPEAKER IMPEDANCE
A or B 6Ω
A + B 12Ω

CAUTION
RISK OF ELECTRIC SHOCK
DO NOT OPEN
WARNING: TO PREVENT FIRE OR SHOCK HAZARD,
DO NOT EXPOSE THIS APPLIANCE TO RAIN OR
MOISTURE.

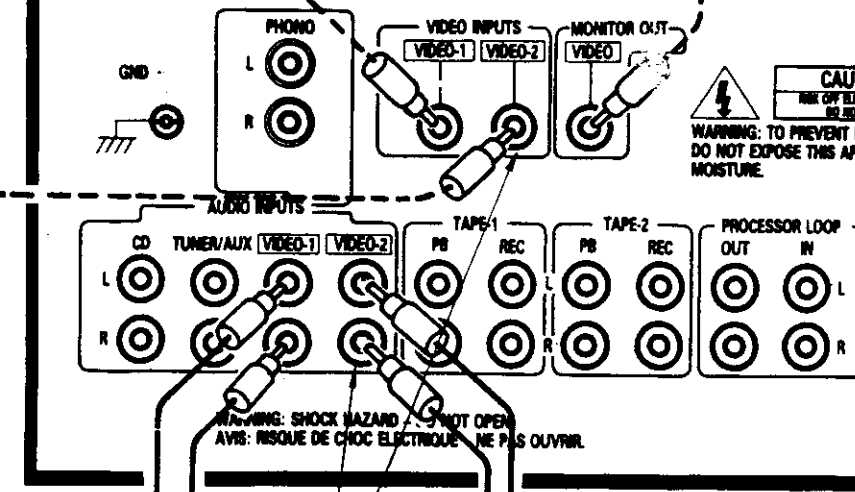

DENON
MODEL NO. PMA-900V
POWER SOURCE 120V - 60Hz
POWER CONSUMPTION
SERIAL NO. _____
NIPPON COLUMBIA CO. LTD.

Note:
The VIDEO-2 terminal is connected in parallel with a terminal on the front side of the panel. Either this terminal or the one on the front panel can be used to make the connection. Improper operation will result if both are connected and used at the same time.

Fig. 6

BLOCK DIAGRAM

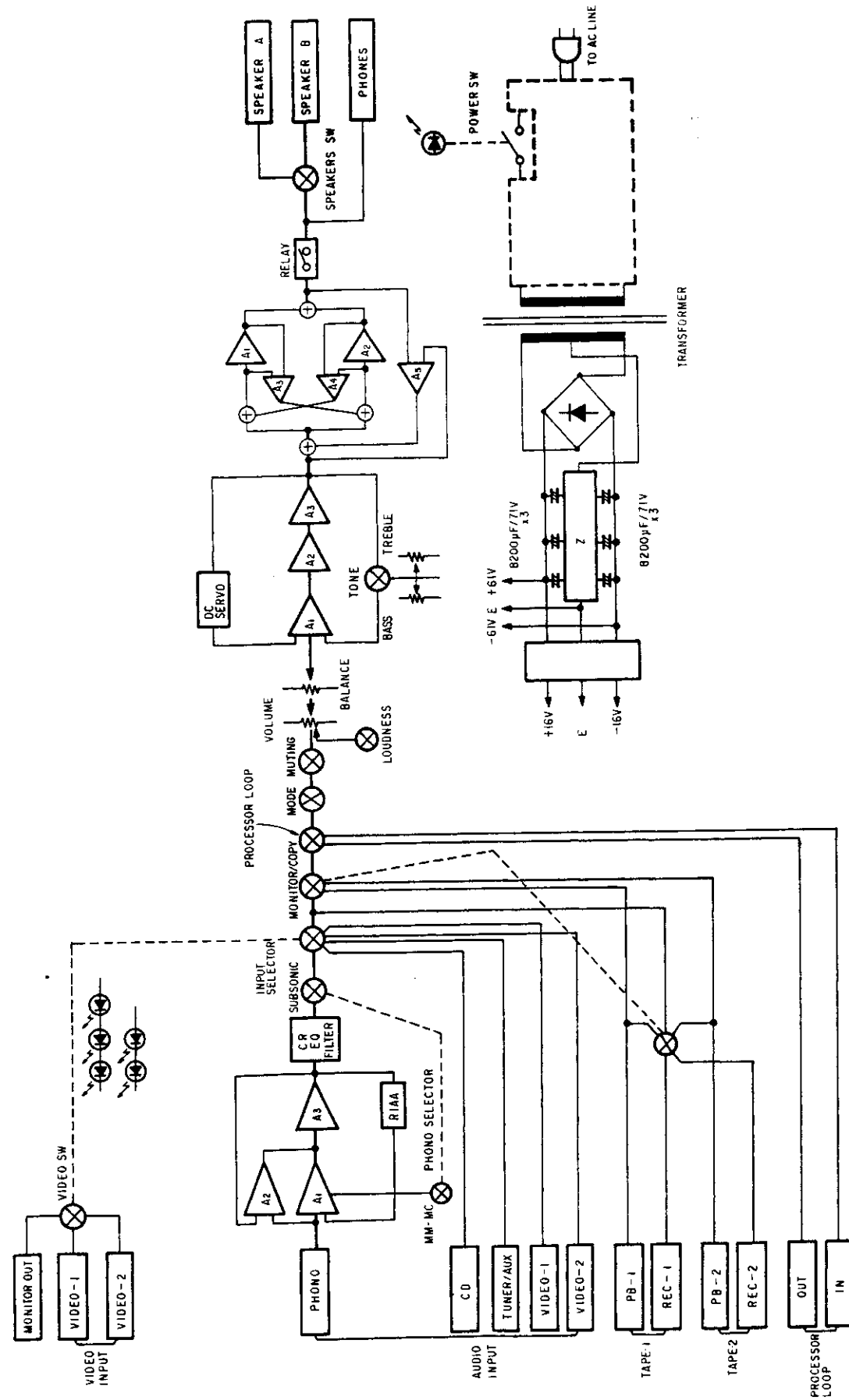

Fig. 7

METHOD OF ADJUSTMENTS

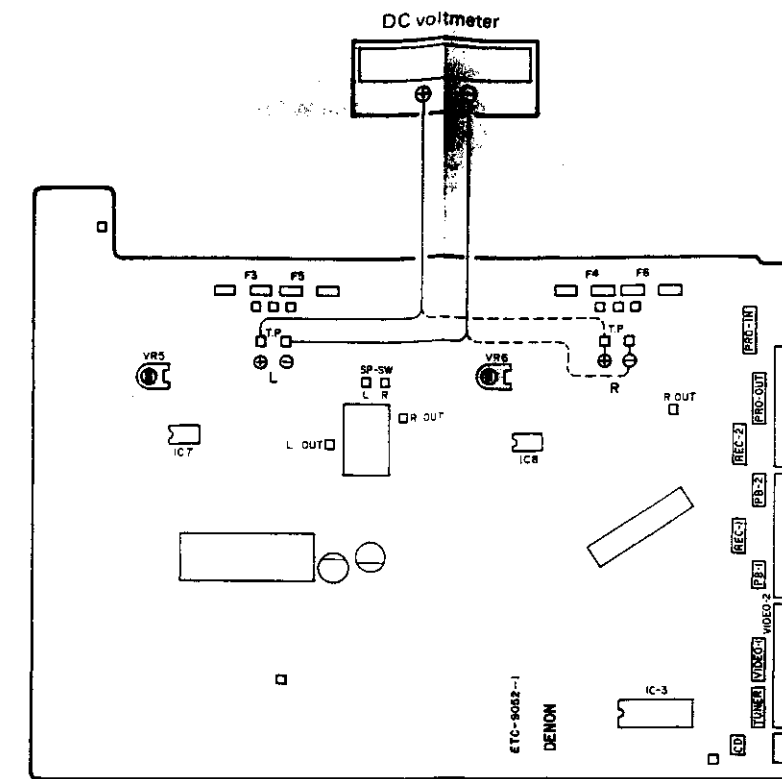

Fig. 8

IDLING CURRENT

• Setup

1. Lay the unit at an ordinary position away from a direct current from a cooler or fan. Do the adjustment at a temperature between 15°C and 30°C.
2. Set controls as follows.
 - POWER SWITCH → off ()
 - VOLUME CONTROL → fully counterclockwise () min)
 - SPEAKER Terminals → open: do not connect the speakers, dummy load etc.

• Adjustment

1. Remove Top cover. And then connect DC Voltmeter to Test points of ETC-9052-1 (INPUT & POWER Unit).
2. Connect Power cord to AC outlet, and turn Power Switch "on" (). Within 10 seconds turn VR5 (Lch) and VR6 (Rch) clockwise so that the DC voltmeter reads.
 - 0.4 ± 0.1 mVDC
3. Then after 5 minutes warmup adjust VR5 and VR6 so that the DC Voltmeter reads.
 - 5 ± 0.5 mV
4. And after 15 minutes warmup adjust VR5 and VR6 so that the DC Voltmeter reads.
 - 8 ± 3 mV

SEMICONDUCTORS

• IC's

FUNCTION OF EACH TERMINAL

TC9152P (Toshiba)

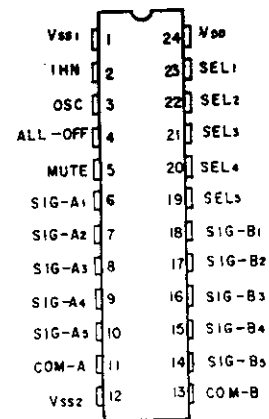

TERMINAL NO.	SYMBOL	FUNCTION	REMARKS
2	INH	Inhibit input terminal. Normal operation at "H" level, inhibit operation at "L" level.	
3	OSC	C.R connecting terminal for oscillator. With this oscillation frequency, muting time and switching time of analog will be set.	
4	ALL-OFF	Specified OFF input terminal of all analog switches. Applying "H" level to turn off all analog switches.	
5	MUTE	Output terminal of muting signal. By receiving of "H" level at select input terminals (SEL-1 ~ SEL-5), this terminal becomes "H" level for settled time and within this time analog switch will shift.	
23 22 21 20 19	SEL-1 SEL-2 SEL-3 SEL-4 SEL-5	Select input terminals for respective analog switches. Turn SEL-1 ~ SEL-5 terminals to "H" level to turn on respective analog switches. SEL-1 ~ SEL-5 are all reciprocal reset. These terminals are in conjunction with driver output I/O terminals.	
6/18	SIG-A ₁ SIG-B ₁	Signal input terminal 1. Select SEL-1 to turn on analog switch 1 and this terminal will conduct to COM terminal.	
7/17	SIG-A ₂ SIG-B ₂	Signal input terminal 2. Select SEL-2 to turn on analog switch 2 and this terminal will conduct to COM terminal.	
8/16	SIG-A ₃ SIG-B ₃	Signal input terminal 3. Select SEL-3 to turn on analog switch 3 and this terminal will conduct to COM terminal.	
9/15	SIG-A ₄ SIG-B ₄	Signal input terminal 4. Select SEL-4 to turn on analog switch 4 and this terminal will conduct to COM terminal.	
10/14	SIG-A ₅ SIG-B ₅	Signal input terminal 5. Select SEL-5 to turn on analog switch 5 and this terminal will conduct to COM terminal.	
11/13	COM-A COM-B	Common terminal for analog switches.	
24 1 12	VDD Vss1 Vss2	Power supply voltage applying terminal. For control system VDD-Vss1. For analog switch system VDD-Vss2.	

M5218P (Mitsubishi)
LA6458DF (Sanyo)

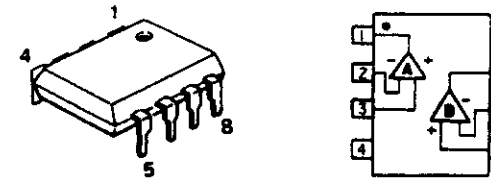

• TRANSISTORS (including FET)

- 2SA1015(Y)
- 2SC1815(BL)
- 2SC2878(A/B)
- 2SA988(E/F)
- 2SC1841(E/F)
- 2SA949(O/Y)
- 2SC2229(O/Y)
- 2SA1358(Y/O) (Green)
- 2SC3421(Y/O) (Black)
- 2SA1106(O)/(Y)
- 2SC2581(O)/(Y)
- 2SA1306(O/Y) (Green)
- 2SC3298(O/Y) (Black)
- FET 2SK381(C)/(D)
- FET 2SK369(BL)/(GR)-C
- 2SK170(BL/V)-DVGS

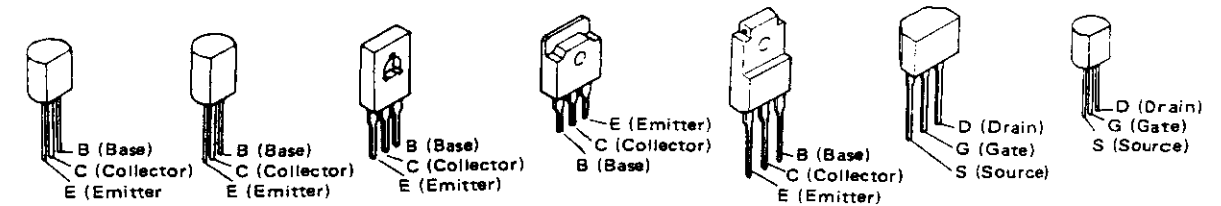

• DIODES (including LED)

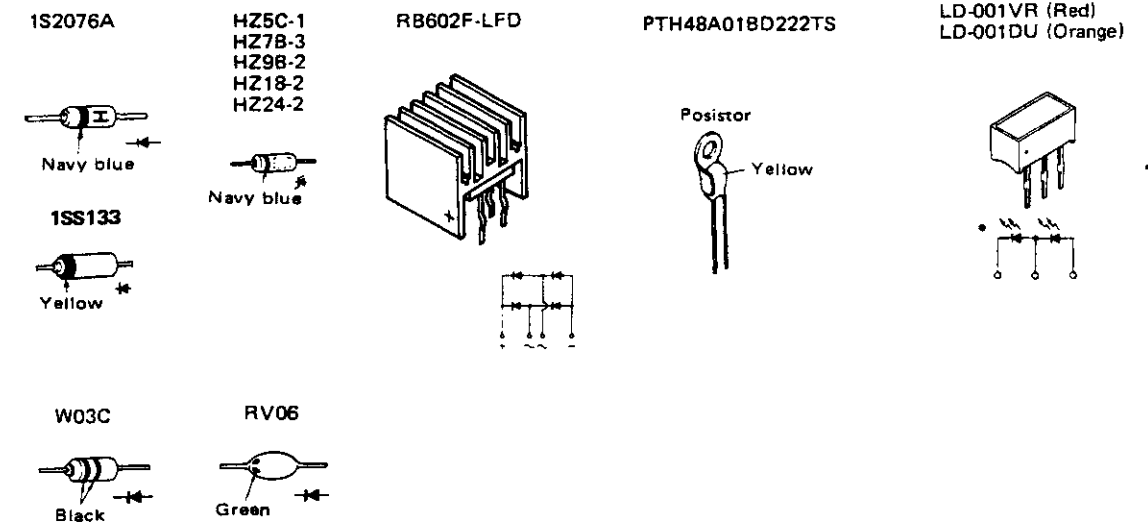

PRINTED WIRING BOARD PATTERNS AND PARTS LIST

ETC9053K EQ. & PS UNIT

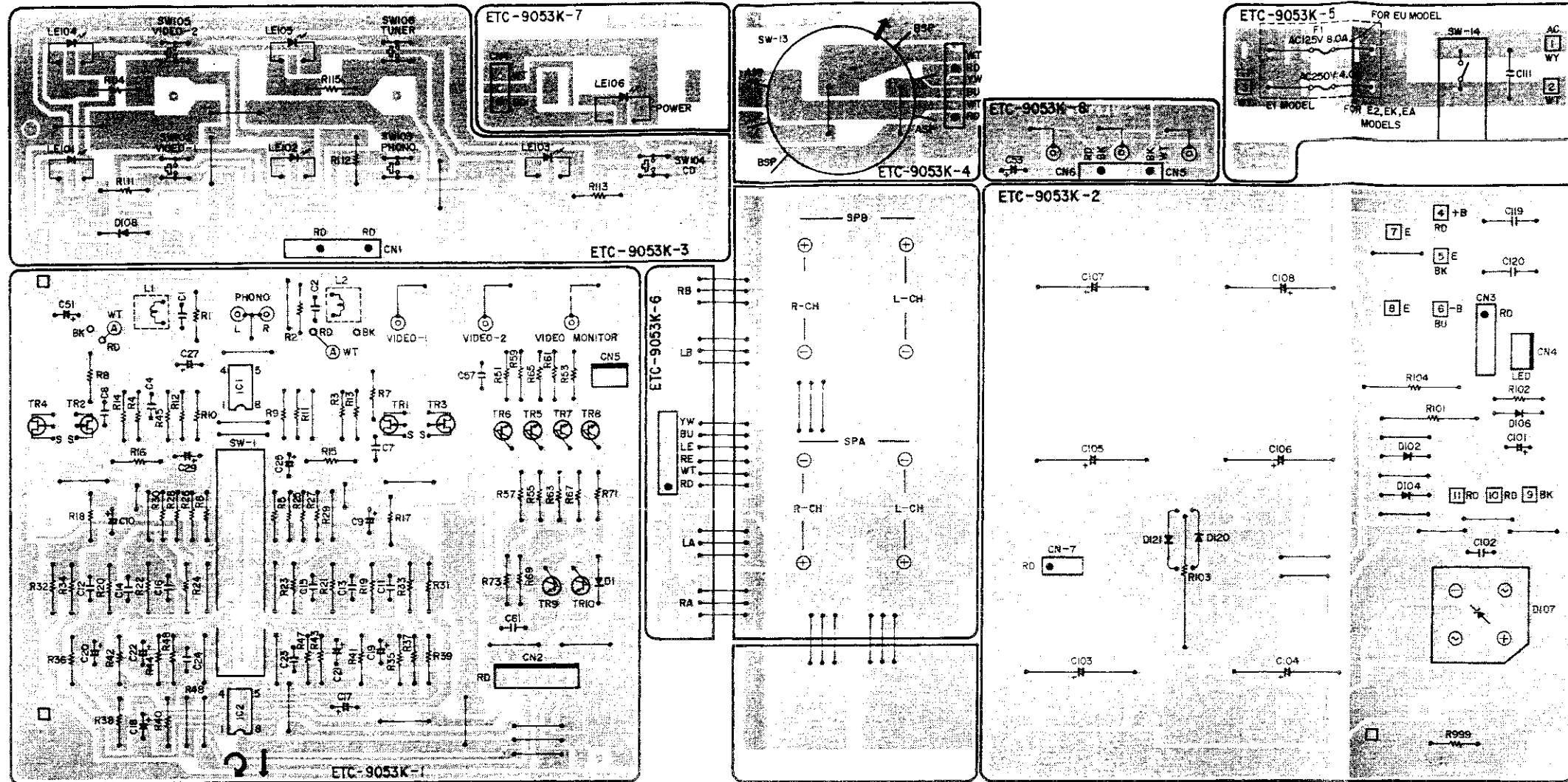

ETC9053K EQ. & PS UNIT PARTS LIST

Ref. No.	Part No.	Part Name & Descriptions
SEMICONDUCTORS		
IC001	2630257001	M-5218P IC (MITSUBISHI)
IC002	2630229013	LA-6848DF IC (SANYO)
TR001	2750038045	2SK369(BL)/(GR)-C FET
TR005	2710102005	2SA1015(Y) TRANSISTOR
TR006	2730198015	2SC1815(BL) TRANSISTOR
TR007	2710102005	2SA1015(Y) TRANSISTOR
TR008	2730198015	2SC1815(BL) TRANSISTOR
D001	2760220021	HZ24-2 ZENER
D102	2760191008	W03C DIODE
D104	2760191008	W03C DIODE
D106	2760249002	HZ18-2 ZENER
D107	2760404009	RB602F-LFD DIODE
D108	2760249002	HZ18-2 ZENER
D120	2760237001	RV06 DIODE
LE101	3939310004	LD-001VR LED (INPUT)
LE106	3939310017	LD-001DU LED (POWER)
RESISTORS (not included Carbon Film ±5%, 1/4W type)		
R101	2440103028	2.7k ohm ±5% 2W METAL OXIDE FILM (NBF)
R103	2432039016	0.47 ohm ±10% 5W WIRE WOUND
R104	2440103028	2.7k ohm ±5% 2W METAL OXIDE FILM (NBF)

Ref. No.	Part No.	Part Name & Descriptions
CAPACITORS		
C001, 002	2533631009	150pF ±5% 50V CERAMIC
C007, 008	2551134025	0.01μF ±5% 50V PLASTIC FILM
C009, 010	2544161021	100μF ±20% 6.3V ELECTROLYTIC
C011, 012	2551140048	0.068μF ±5% 50V PLASTIC FILM
C013, 014	2551140035	0.018μF ±5% 50V PLASTIC FILM
C015, 016	2554149004	1500pF ±5% 50V PLASTIC FILM
C017, 108	2544161021	100μF ±20% 6.3V ELECTROLYTIC
C019, 020	2544147003	2.2μF 50V ELECTROLYTIC
C021, 022	2544146004	1μF 50V ELECTROLYTIC
C023, 024	2554157009	3300pF ±5% 50V PLASTIC FILM
C025	2544146004	1μF 50V ELECTROLYTIC
C027	2544146004	1μF 50V ELECTROLYTIC
C029	2544011003	220μF 10V ELECTROLYTIC
C031, 032	2544114007	10μF ±20% 35V ELECTROLYTIC
C051	2544146004	1μF 50V ELECTROLYTIC
C053	2544146004	1μF 50V ELECTROLYTIC

Ref. No.	Part No.	Part Name & Descriptions	Q'ty
C057	2531024003	0.01μF +80,-20% 50V CERAMIC	
C061	2531024003	0.01μF +80,-20% 50V CERAMIC	
C101	2544060009	10μF 100V ELECTROLYTIC	
C102	2538011006	0.01μF +80,-20% 250V (AC) CERAMIC	
C103	2546094002	8200μF ±20% 71V ELECTROLYTIC	
C111	2538003014	0.0047μF +100,-0% 400V (AC) CERAMIC	
C591, 592	2531008003	4700pF ±10% 50V CERAMIC	
SWITCHES & COILS			
SW001	2129521002	SLIDE SW REMOTE (PHONO)	
SW013	2129522001	ROTARY SWITCH (SPEAKER)	
SW014	2129525008	POWER SWITCH	
SW102	2124407008	TACT SWITCH (INPUT)	
L001, 002	2359003002	FTZ CHOKE COIL	
OTHER PARTS			Q'ty
	2229054107	P.W. BOARD	1
	2090008120	JUMPER WIRE P=10mm	60
	EP-5667H1	TERMINAL PIN L=21mm	10
	2020022008	FUSE HOLDER	2
F001	2061015087	FUSE (4A) (MINI SIZE WITHSTAND RUSH)	1

Ref. No.	Part No.	Part Name & Descriptions	Q'ty
	2050274004	2P CONNECTOR BASE	1
	2050240009	3P CONNECTOR BASE	1
	2048182014	3P CONNECTOR BASE	1
	2050273005	4P TERMINAL	2
	4450057010	CORD CLIP	2
CN001	2042052098	7P NH CONNECTOR CORD (TACT SW & LED)	1
CN002	2050190078	7P NH CONNECTOR BASE (EQ & VIDEO SW)	1
CN003	2038123067	5P NH CONNECTOR CORD (+ - B & MUTING)	1
CN003	2050185054	5P WIRE HOLDER (+ - & MUTING)	1
CN004	2050190036	3P NH CONNECTOR BASE (F-VIDEO)	1
CN004	2034185012	3P CONNECTOR CORD (POWER LED)	1
CN004	2050185038	3P WIRE HOLDER (POWER LED)	1
CN005	2050190036	3P NH CONNECTOR BASE (PO-LED)	1
CN005	2034282009	3P CONNECTOR CORD (FRONT VIDEO-2)	1
CN006	2034200023	3P CONNECTOR CORD (F-VIDEO-2, BK)	1
	2050185067	6P WIRE HOLDER (VIDEO-2)	3
	2050243077	7P WIRE HOLDER (TACT SW & LED)	1
	2030241028	1P CONTACT ASSY (FRONT VIDEO-2)	1

E1 for Asia ETC9053M
(Same as ETC9053K (for E2) except the followings.)

Ref. No.	Part No.	Part Name & Descriptions
RESISTORS		
R001, 002	2412100004	2.2k ohm ±5% 1/4W CARBON DELETE
CAPACITORS		
C001, 002 AC111	2533627000 2538003014	100pF ±5% 50V CERAMIC CHANGE 0.0047μF ±20% 400V(AC) CERAMIC DELETE
C591, 592	2531008003	4700pF ±10% 50V CERAMIC DELETE
SWITCH & COILS		
ASW014 L001, 002	2129534002 2359003002	POWER SWITCH DELETE FTZ CHOKE COIL (2) DELETE
OTHER PARTS		
AF001	2020022008 2061015087 2090008120	FUSE HOLDER (2) DELETE FUSE (4A) DELETE JUMPER WIRE P=10mm (2) ADD

EU for U.S.A. ETC9053N
(Same as ETC9053K (for E2) except the followings.)

Ref. No.	Part No.	Part Name & Descriptions
RESISTORS		
R001, 002	2421000004	2.2k ohm ±5% 1/4W CARBON DELETE
CAPACITORS		
C001, 002 AC111	2533627000 2538003014	100pF ±5% 50V CERAMIC CHANGE 0.0047μF ±20% 400V(AC) CERAMIC DELETE
C591, 592	2531008003	4700pF ±10% 50V CERAMIC DELETE
SWITCH & COILS		
ASW014 L001, 002	2129534002 2359003002	POWER SWITCH DELETE FTZ CHOKE COIL (2) DELETE
OTHER PARTS		
AF001	2020022008 2061015087 2090008120	FUSE HOLDER (2) DELETE FUSE (4A) DELETE JUMPER WIRE P=10mm (2) ADD

EK for U.S. and EA for Australia ETC9053P and ETC9053Q
(Same as ETC9053K (for E2) except the followings.)

Ref. No.	Part No.	Part Name & Descriptions
RESISTORS		
R001, 002	2412100004	2.2k ohm DELETE
SWITCH & COILS		
L001, 002	2359003002	FTZ CH. KE COIL (2) DELETE
OTHER PARTS		
	2090008120	JUMPER WIRE P=10mm (2) ADD

ETC9052K INPUT & POWER UNIT PARTS LIST

Ref. No.	Part No.	Part Name & Descriptions
SEMICONDUCTORS		
IC003 IC005 ~008	2620581004 2630257001	TC9152P IC (TOSHIBA) M-5218P IC (MITSUBISHI)
TR151	2730198015	2SC1815(BL) TRANSISTOR
TR152	2710102005	2SA1015(Y) TRANSISTOR
TR153	2730198015	2SC1815(BL) TRANSISTOR
TR155, 156	2730253015	2SC2878(A/B) TRANSISTOR
TR201, 202	2730198015	2SC7815(BL) TRANSISTOR
TR203	2730235020	2SC1841(E/F) TRANSISTOR
TR204	2710102005	2SA1015(Y) TRANSISTOR
TR205	2730253015	2SC2878(A/B) TRANSISTOR
TR206	2730198015	2SC1815(BL) TRANSISTOR
TR208	2710102005	2SA1015(Y) TRANSISTOR
TR209	2730323000	2SC3421(O/Y) TRANSISTOR
TR210	2710195009	2SA1358(O/Y) TRANSISTOR
TR211, 212	2750043001	2SK381(B) IC FET
TR401 ~104	2750046008	2SK170(BL/V) DVGS FET
TR405 ~408	2730235020	2SC1841(E/F) TRANSISTOR
TR409 ~414	2710185006	2SA949(O)/(Y) TRANSISTOR
TR415, 416	2730307000	2SC2229(O)/(Y) TRANSISTOR
TR417, 418	2710185006	2SA949(O)/(Y) TRANSISTOR
TR419, 420	2730307000	2SC2229(O)/(Y) TRANSISTOR
TR501, 502	2730198015	2SC1815(BL) TRANSISTOR
TR503, 504	2730307000	2SC2229(O)/(Y) TRANSISTOR
TR505, 506	2710185006	2SA949(O)/(Y) TRANSISTOR
TR507, 508	2730324009	2SC3298(O/Y) TRANSISTOR
TR509, 510	2710196008	2SA1306(O/Y) TRANSISTOR
D152, 153	2760401002	1SS133 DIODE
D171 ~173	2760401002	1SS133 DIODE
D201	2760049011	1S2076A DIODE
D202	2760249002	HZ18-2 ZENER
D208	2760049011	1S2076A DIODE
D401 ~406	2760401002	1SS133 DIODE
D501 ~504	2760218033	HZ9B-2 ZENER
D505, 506	2760236031	HZ5C-1 ZENER
D507 ~510	2760254000	HZ7B-3 ZENER
D511 ~522	2760401002	1SS133 DIODE
D523 ~526	2760049011	1S2076A DIODE
D527 ~530	2760401002	1SS133 DIODE
D531, 532	2760049011	1S2076A DIODE
RESISTORS (not included Carbon Film ±5%, 1/4W Type)		
R201, 202	2440038025	560 ohm ±5% 1W METAL OXIDE FILM (NBF)
R207	2440039024	680 ohm ±5% 1W METAL OXIDE FILM (NBF)
R413 ~416	2412369094	240 ohm ±5% 1/4W CARBON (NBF)
R421, 422	2412379987	1k ohm ±5% 1/4W CARBON (NBS)

Ref. No.	Part No.	Part Name & Descriptions
R423, 424	2412375947	47 ohm ±5% 1/4W CARBON (NBS)
R433	2412376964	100 ohm ±5% 1/4W CARBON (NBS)
R434	2412376964	47 ohm ±5% 1/4W CARBON (NBS)
R435 ~438	2412321061 2412375981	47 ohm ±5% 1/4W CARBON (NBF) 22 ohm ±5% 1/4W CARBON (NBS)
R501 ~508	244003023	1.5k ohm ±5% 1W METAL OXIDE FILM (NBF)
R545 ~548	2412379987	1k ohm ±5% 1/4W CARBON (NBS)
R549, 550	2412314023	470 ohm ±5% 1/4W CARBON (NBF)
R551 ~554	2412377947	100 ohm ±5% 1/4W CARBON (NBS)
R559, 560	2412314007	100 ohm ±5% 1/4W CARBON (NBF)
R561 ~566	2440013024	4.7 ohm ±5% 1W METAL OXIDE FILM (NBF)
R567 ~574	2442013080	0.22 ohm ±5% 1W METAL OXIDE FILM (NBF)
R585, 586	2440021029	22 ohm ±5% 1W METAL OXIDE FILM (NBF)
R587, 588	2440015022	6.8 ohm ±5% 1W METAL OXIDE FILM (NBF)
R589, 590	2440013024	4.7 ohm ±5% 1W METAL OXIDE FILM (NBF)
R591, 592	2440030023	120 ohm ±5% 1W METAL OXIDE FILM (NBF)
R595, 596	2412321003	1k ohm ±5% 1/4W CARBON (NBF)
VR001	2119020005	MAIN VR 100k ohm
VR002	2119021004	BALANCE VR 200k ohm
VR003	2119022016	BASS VR 250k ohm
VR004	2119022003	TREBLE VR 50k ohm
VR005, 006	2116000099	SEMIFIXED RESISTOR BIAS (2k ohm)
CAPACITORS		
C055	2544132005	10μF 16V ELECTROLYTIC
C059	2544146004	1μF 50V ELECTROLYTIC
C151	2531004007	1000pF ±10% 50V CERAMIC
C155	2544019005	220μF 16V ELECTROLYTIC
C157	2531024003	0.01μF +80, -20% 50V CERAMIC
C171	2544146004	1μF 50V ELECTROLYTIC
C201, 202	2544146004	1μF 50V ELECTROLYTIC
C203	2554137003	470pF ±5% 50V PLASTIC FILM
C204	2544141009	10μF 35V ELECTROLYTIC
C205	2544127007	220μF 6.3V ELECTROLYTIC
C206	2544006005	470μF 6.3V ELECTROLYTIC
C207	2544132005	10μF 16V ELECTROLYTIC
C301, 302	2531004007	1000pF ±10% 50V CERAMIC
C303, 304	2551140051	0.082μF ±5% 50V PLASTIC FILM
C401, 402	2554121006	100pF ±5% 50V PLASTIC FILM
C403, 404	2554137003	470pF ±5% 50V PLASTIC FILM
C405, 406	2531008003	4700pF ±10% 50V CERAMIC
C407, 408	2534269001	10pF ±0.5pF 500V CERAMIC
C409, 410	2531024003	0.01μF +80, -20% 50V CERAMIC
C411, 412	2534355009	5pF ±0.25pF 500V CERAMIC
C413, 414	2533627000	100pF ±5% 50V CERAMIC
C415, 416	2533643000	470pF ±5% 50V CERAMIC
C417, 418	2544150003	10μF 50V ELECTROLYTIC

Ref. No.	Part No.	Part Name & Descriptions	Ref. No.	Part No.	Part Name & Descriptions	Q'ty
C419, 420	2534273000	15pF ±5% 500V CERAMIC	L501, 502	2359001004	INDUCTOR (2μH)	2
C421, 422	2534271002	12pF ±0.5pF 500V CERAMIC		4140240001	EARTH PLATE (GND)	1
C425, 426	2544146004	1μF 50V ELECTROLYTIC		2048191005	HEADPHONE JACK	1
C427	2544060038	0.47μF 100V ELECTROLYTIC	F003 ~006	2020022008	FUSE HOLDER (+ - B)	8
C428	2544181001	1μF ±20% 100V ELECTROLYTIC		2050274004	2P CONNECTOR BASE	1
C429, 430	2544127007	220μF 6.3V ELECTROLYTIC		2050152003	6P CONNECTOR BASE	3
C437	2544060038	0.47μF 100V ELECTROLYTIC	CN001	2050190078	7P NH CONNECTOR BASE (TACT SW & LED)	1
C451, 452	2551121041	0.015μF ±5% 50V PLASTIC FILM	CN002	2050185070	7P WIRE HOLDER	1
C453, 454	2551140064	0.12μF ±5% 50V PLASTIC FILM	CN002	2042052014	7P CONNECTOR CORD (EQ & VIDEO SW)	1
C457, 458	2551121007	6800pF ±5% 50V PLASTIC FILM	CN003	2050190052	5P NH CONNECTOR BASE	1
C459, 460	2551120013	1200pF ±5% 50V PLASTIC FILM	CN006	2050190036	3P NH CONNECTOR BASE (FRONT VIDEO-2)	1
C461, 462	2551135095	0.056μF ±5% 50V PLASTIC FILM		2050190036	3P NH CONNECTOR BASE (POWER INPUT)	1
C465, 466	2533633007	180pF ±5% 50V CERAMIC	W-003	2050185038	3P WIRE HOLDER	14
C501 ~504	2544139008	100μF 25V ELECTROLYTIC		2034200010	3P CONNECTOR CORD	1
C505, 506	2533603008	10pF ±0.5pF 50V CERAMIC	F003 ~006	4450033005	WIRE CLAMP BAND	4
C507 ~510	2533639001	330pF ±5% 50V CERAMIC		2061040023	FUSE (6.3A, F)	1
C511, 512	2544132005	10μF 16V ELECTROLYTIC	FEP-1261		JUMPER WIRE	1
C513, 514	2544146004	1μF 50V ELECTROLYTIC				
C519 ~522	2531024003	0.01μF +80,-20% 50V CERAMIC				
C523 ~526	2531024003	0.01μF +80,-20% 50V CERAMIC				
C527 ~530	2533627000	100pF ±5% 50V CERAMIC				
C531 ~534	2534281005	33pF ±5% 500V CERAMIC				
C535 ~538	2531005006	1500pF ±10% 50V CERAMIC				
C539, 540	2551121025	0.01μF ±5% 50V PLASTIC FILM				
C541, 542	2551121067	0.022μF ±5% 50V PLASTIC FILM				
C543 ~546	2544181001	1μF ±20% 100V ELECTROLYTIC				
C551 ~554	2551135095	0.056μF ±5% 50V PLASTIC FILM				
C555, 556	2531024003	0.01μF +80,-20% 50V CERAMIC				
C631, 632	2533635005	220pF ±5% 50V CERAMIC				
		SWITCHES & RELAY				Q'ty
SW007	2124254002	SLIDE SW (REMOTE) T. MONI				1
SW008	2129520003	1P PUSH SW (PROCESSOR LOOP)				1
SW009 ~011	2129524009	3P PUSH SW(MODE,LOUD & MUTE)				1
SW012	2129520003	1P PUSH SW TONE				1
RL001	2140037009	RELAY SP 48V				1
		OTHER PARTS				Q'ty
J701 ~703	2229053302	P.W. BOARD				1
J705	2090008146	JUMPER WIRE P=5mm				15
J018	2090008120	JUMPER WIRE P=10mm				223
	2090008104	JUMPER WIRE P=15mm				4
	2090008159	JUMPER WIRE P=17.5mm				1
	EP-5667H1	TERMINAL PIN L=21mm				12
	4170043100	RADIATOR (FOR TR209, 210)				2
	4730354019	TAPPING SCREW (2) 3x8				2

E1 for Asia ETC9052M
(Same as ETC9052K (for E2) except the followings.)

Ref. No.	Part No.	Part Name & Descriptions	
OTHER PARTS			
F003 ~006	2061041035	FUSE (F) 6.3A (4)	CHANGE
	5139134004	FUSE LABEL	ADD.

EU for U.S.A. ETC9052N
(Same as ETC9052K (for E2) except the followings.)

Ref. No.	Part No.	Part Name & Descriptions	
RESISTORS			
R409, 410	2412068007	100 ohm ±5% 1/4W CARBON	CHANGE
R417, 420	2412080001	330 ohm ±5% 1/4W CARBON	CHANGE
AR587, ~588	2440021029	22 ohm ±5% 1W METAL OXIDE (NB)	CHANGE
CAPACITORS			
C631, 632	2533635005	220pF ±5% 50V CERAMIC	DELETE
OTHER PARTS			
AF003 ~006	5139134004	FUSE LABEL	ADD
	2061040023	FUSE 6.3A F (4)	CHANGE

EK for U.K. and EA for Australia ETC9052P. and ETC9052Q
(Same as ETC9052K (for E2))

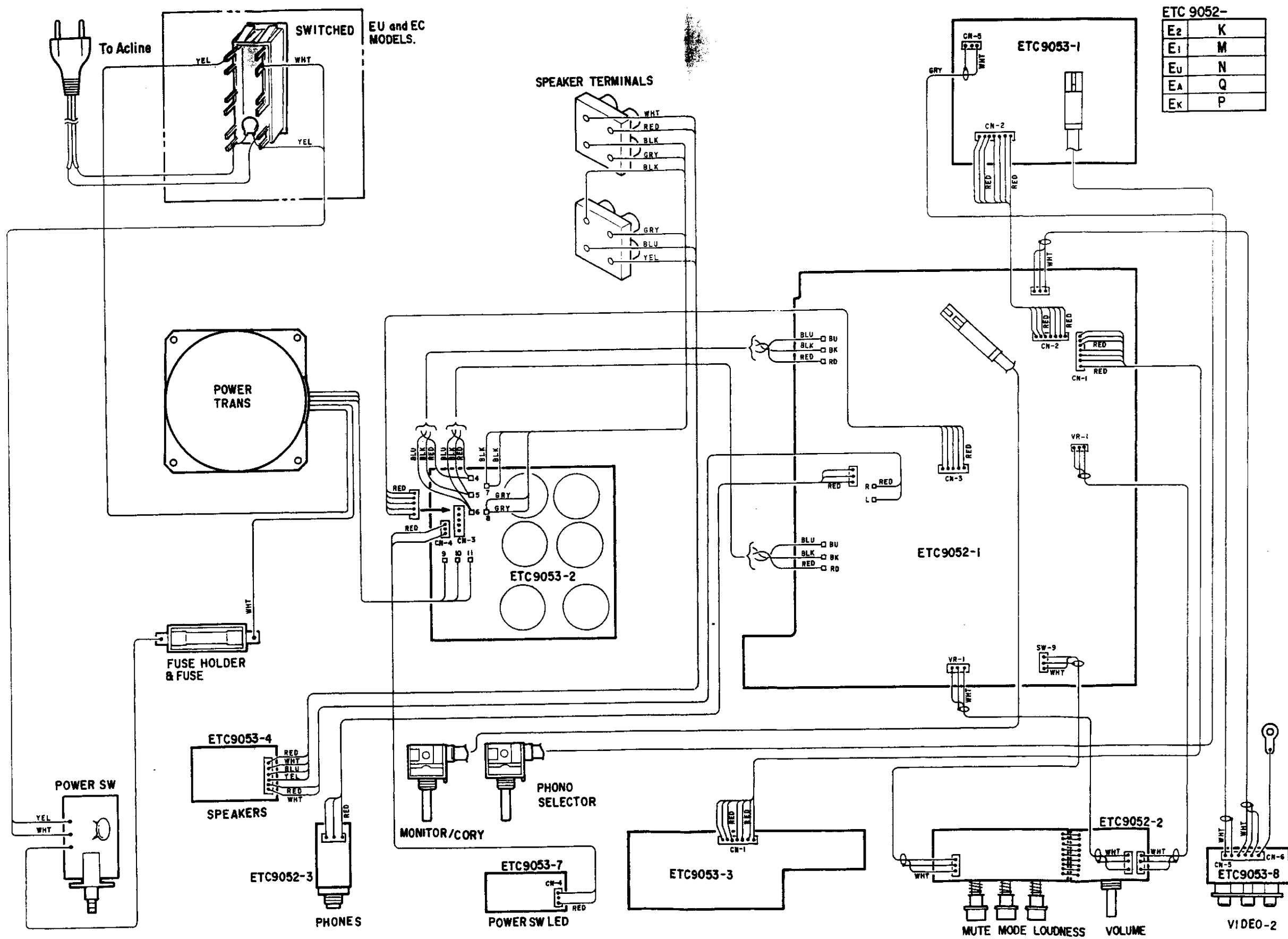

ETC 9052-

E2	K
E1	M
Eu	N
EA	Q
Ek	P

ETC 9053-

E2	K
E1	M
Eu	N
EA	Q
Ek	P

WIRING DIAGRAM
E2 & EK Models (Same as E2 version except the following)

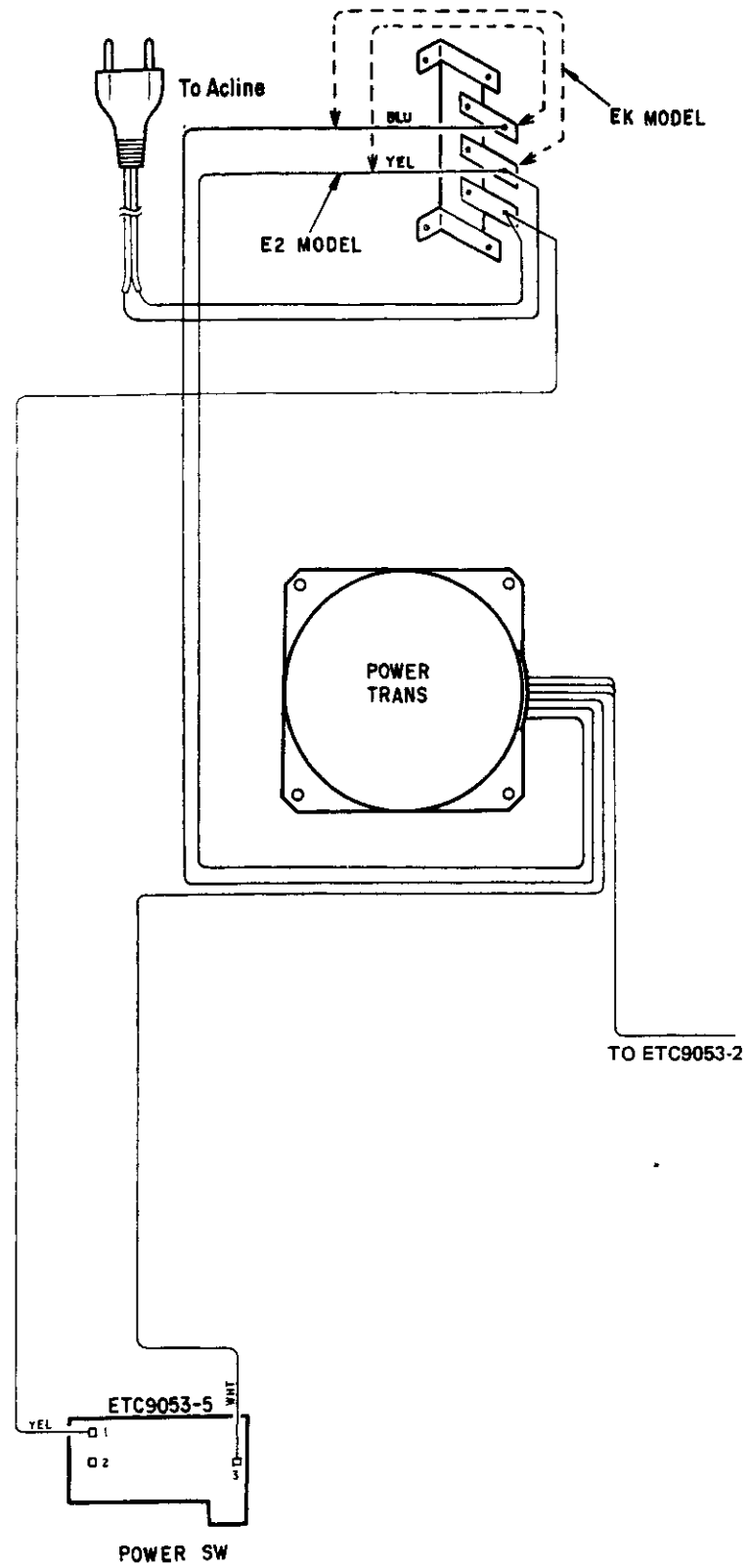

WIRING DIAGRAM
E1 Model (Same as E2 version except the following)

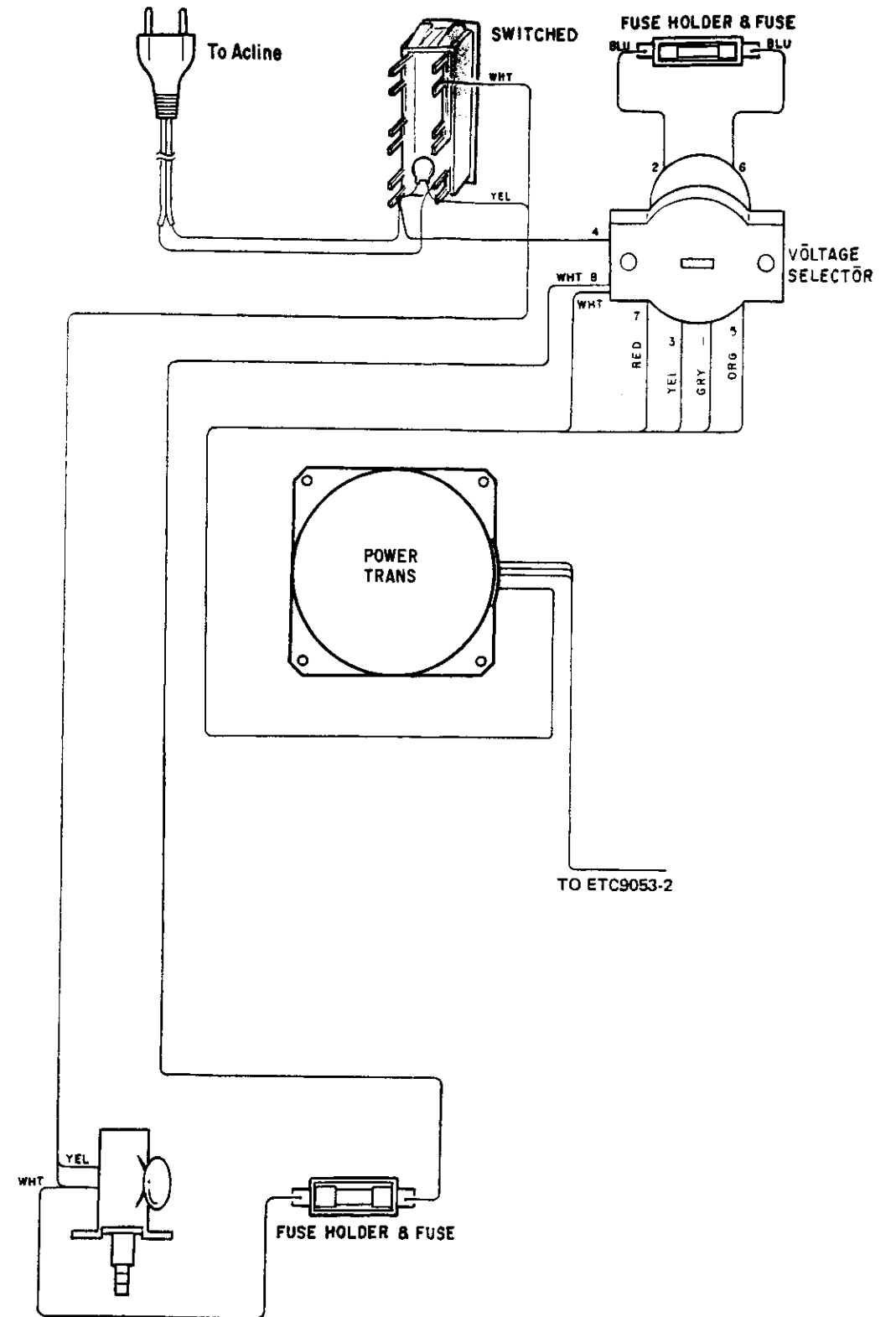

EXPLODED VIEW OF CHASSIS AND CABINET
(This figure is specifications of E2.)

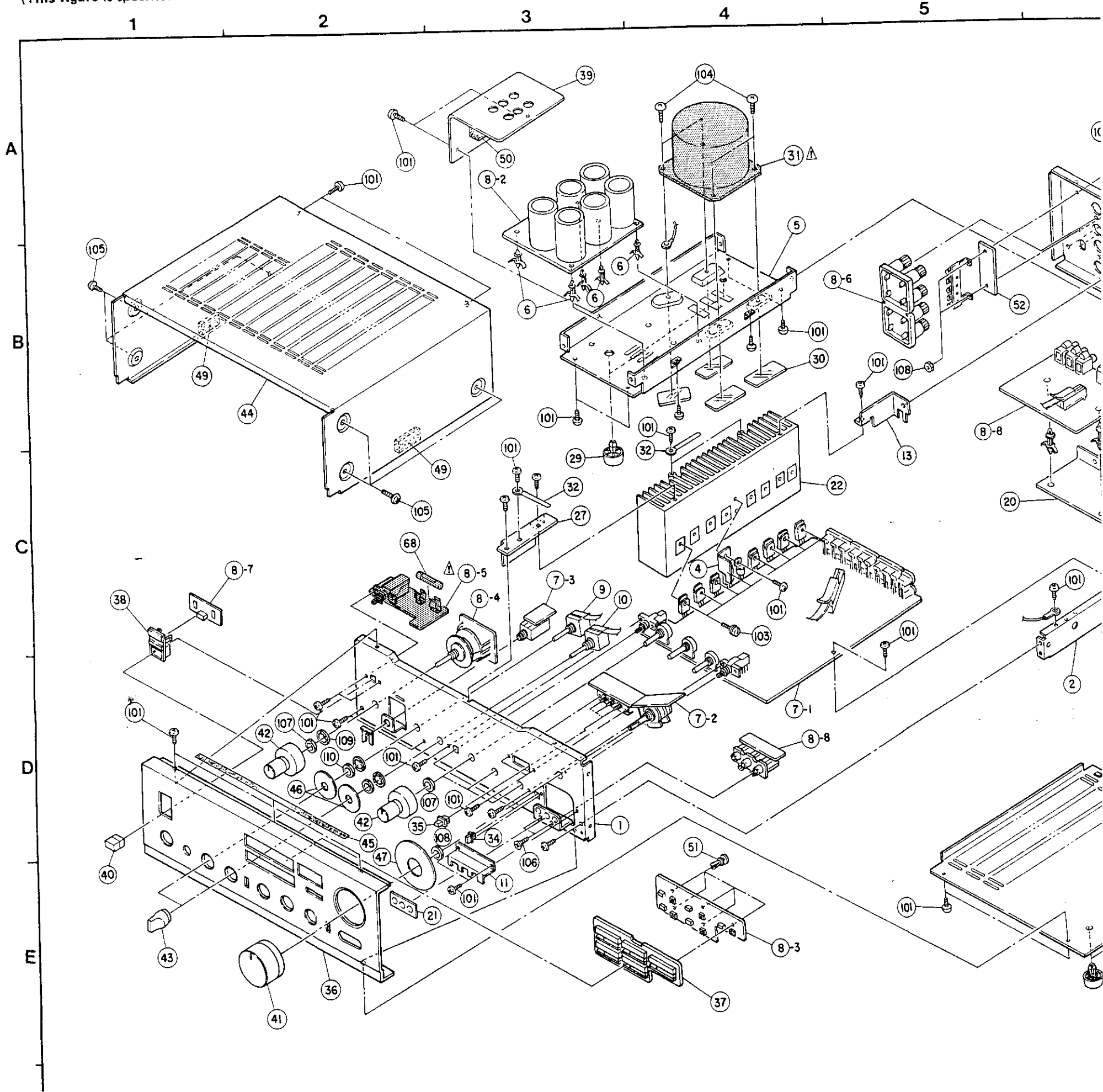

Note 1. See addendum list below for the parts with asterisk (*) on the Ref. No. and the other parts not included in the list.
 2. * marked not included EXPLODED VIEW OF CHASSIS AND CABINET.
 3. This list is prepared based on E2 BLACK VERSION.

EXPLODED VIEW OF PARTS LIST for E2 BLACK VERSION

Ref. No.	Part No.	Part Name & Descriptions	Q'ty	Ref. No.	Part No.	Part Name & Descriptions	Q'ty	Ref. No.	Part No.	Part Name & Descriptions	Q'ty
1	4119019409	FRONT CHASSIS	1	27	4129039107	RADIATOR BRACKET	1	SCREWS, NUTS			
2	4119020207	SIDE CHASSIS	1	28	1059044207	BOTTOM COVER	1				
3	4129038001	P.W.B BRACKET	1	29	1049003009	FOOT	4	*101	4737002034	TAPPING SCREW (S) BLACK 3x6	5
4	4129044008	BRACKET	1	30	4149017002	SAFETY PLATE	4	102	4737500044	TAPPING SCREW (P) BLACK 3x8	1
5	4119021206	TRANS CHASSIS	1	*31	2339548105	POWER TRANS	3	103	4700012022	CROSS PAN SCREW WITH SW, W 3x12	1
6	4150228000	P.C.B HOLDER	1s	*32	4450048016	CORD HOLDER (L50)	3	104	4737004016	TAPPING SCREW (S) 4x6	1
*7	ETC9052K	INPUT & POWER UNIT	1s	*33	4450033005	WIER CLAMP BAND	10	*105	4737007000	TAPPING SCREW (S) BLACK 4x8	1
*8	ETC9053K	EQ. & PS. UNIT	1s	*34	1139071006	PUSH KNOB (T)	2	106	-	-	-
9	2123614009	ROTARY REMOTE SW (T. MONI)	1	*35	1139072005	PUSH KNOB (L)	3	107	-	-	-
10	2123614012	ROTARY REMOTE SW (PHONO)	1	*36	1449030119	FRONT PANEL ASS'Y	1	108	4756006008	NUT M3	-
11	-	-	-	*37	1139073224	PUSH KNOB (F) ASS'Y	1	PACKING & ACCESSORIES (not included EXPLODED VIEW)			
*12	1059052118	BACK PANEL	1	*38	1469044101	KNOB GUIDE (P) ASS'Y	1				
13	4129040002	BRACKET	1	*39	4129066002	CON. HOLD BRACKET	1	202	5050075051	CABINET COVER	-
14	2050071016	TERMINAL ASS'Y	1	*40	1139070104	PUSH KNOB (P)	1	203	5039123102	CUSHION	-
15	4770018001	WASHER (P-87)	1	*41	1129012004	VR KNOB ASS'Y	4	*204	5019101050	CARTON CASE	-
*16	2062002031	AC CORD	1	*42	1129013207	KNOB ASS'Y	2	205	5119171003	INST. MANUAL	-
*17	4450020005	CORD BUSH (4K-4)	1	*43	1129014109	KNOB ASS'Y	2	*206	5138295009	CONTROL CARD	-
18	-	-	-	*44	1029013213	TOP COVER	1	-	-	-	-
*19	2538010007	CERAMIC CAPACITOR (0.01μF 400V AC)	1	45	1220095014	SPACER	1	-	-	-	-
20	2129041001	P.W.B SUPPORT	1	46	1229007029	BLIND RING	2	-	-	-	-
21	1469045100	BLIND SHEET	1	47	1229007032	BLIND RING	1	-	-	-	-
22	4179012116	POWER RADIATOR	1	48	1229006033	SPACER	3	-	-	-	-
23	4150234007	INSULATING SHEET	8	*49	4619001001	RUBBER SHEET	2	-	-	-	-
24	2730273011	TRANSISTOR 2SC2581(O)/(Y) (TRF11-514)	4	*50	4619001030	RUBBER SHEET	1	-	-	-	-
25	2710160018	TRANSISTOR 2SA1106(O)/(Y) (TRF16-518)	4	51	4770210016	PUSH RIVET	5	-	-	-	-
26	2760289004	POSITIVE THERMISTOR PTH487A01BD222TS	1	*52	4150088004	INSULATING SHEET	1	-	-	-	-
				*53	2050089008	7P W. TERMINAL	1	-	-	-	-
				54	1220114005	SPACER	2	-	-	-	-
				*55	4129050005	BRACKET (3P)	1	-	-	-	-

⚠ Means important safety item, which must be replaced, when necessary, by a part specified or meeting the specification by the manufacturer.

6 7

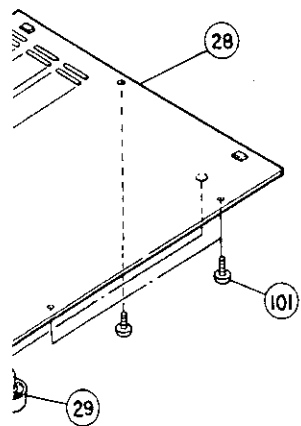
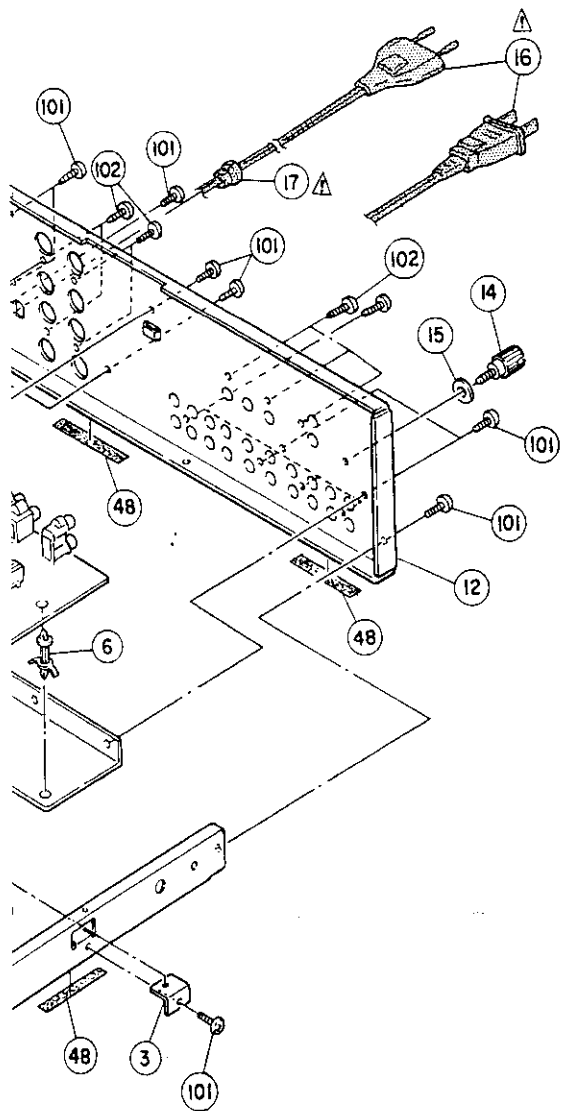

WARNING:

1. Component parts

Parts marked with ⚠ and/or shading in this service manual have special characteristics important to safety. Be sure to use the specified parts for replacement.

2. Leakage current

Before returning the appliance to customer, test the leakage current when the power plug is connected. Use a calibrated (with an error of not more than 5%) leakage current tester and measure the leakage current from any exposed metal to the earth ground. Reverse the power plug polarity and test the above again.

Any current measured **MUST NOT EXCEED 0.5 milliamps**. Corrective measure must be taken if it exceeds the limit.



CAUTION
RISK OF ELECTRIC SHOCK
DO NOT OPEN



CAUTION: TO REDUCE THE RISK OF ELECTRIC SHOCK, DO NOT REMOVE COVER (OR BACK). NO USER SERVICEABLE PARTS INSIDE. REFER SERVICING TO QUALIFIED SERVICE PERSONNEL.



The lightning flash with arrowhead symbol within an equilateral triangle is intended to alert the user of the presence of uninsulated "dangerous voltage" within the product's enclosure that may be of sufficient magnitude to constitute a risk of electric shock to persons.



The exclamation point within an equilateral triangle is intended to alert the user of the presence of important operating and maintenance (servicing) instructions in the literature accompanying the appliance.

WARNING: TO PREVENT FIRE OR SHOCK HAZARD, DO NOT EXPOSE THIS APPLIANCE TO RAIN OR MOISTURE.

ADDENDUM LIST

Ref. No.	Part Name & Descriptions	Part No.				
		E1 for Asia	EU for U.S.A.	EA for Australia	EK for U.K.	EC for Canada
7	INPUT & POWER UNIT	ETC9052M	ETC9052N	ETC9052Q	ETC9052P	ETC9052R
⚠ 8	EQ. & P.S. UNIT	ETC9053M	ETC9053N	ETC9053Q	ETC9053P	ETC9053R
12	BACK PANEL	1059055115	1059042128	1059052118	1059052118	1059042128
⚠ 16	AC CORD	2006031026	2062039004	2062012018	2062024006	2062039004
⚠ 17	CORD BUSH	4450028007	4450020005	MD-2982H	4450020005	4450020005
⚠ 19	CAPACITOR			2538010007	2538010007	
⚠ 21	POWER TRANS.	2339549007	2330543100	2339548105	2339548105	2339543100
36	FRONT PANEL ASS'Y	1449030106	1449030106	1449030119	1449030119	1449030106
37	PUSH KNOB (F) ASS'Y	1139073208	1139073208	1139073224	1139073224	1139073208
44	TOP COVER	1029013310	1029013249	1029013310	1029013310	1029013349
52	INSULATING SHEET	-	-	4150088004	4150088004	-
53	7P W. TERMINAL	-	-	2050089008	2050089008	-
61	VOLTAGE LABEL	-	-	5130362008 (2)	5130362008 (2)	-
62	BLIND SHEET	-	-	5139132006	5139132006	-
63	EARTH LABEL	-	-	5130140000	-	-
64	NOTICE SHEET	-	-	5130209006	-	-
65	NOTICE SHEET	-	-	5130210008	-	-
⚠ 66	AC OUTLET (POLARIZED)	2033926007	2033926007	-	-	2033926007
⚠ 67	FUSE HOLDER	2020013101	2020013101	-	-	2020013101
⚠ 68	FUSE (8A)	2081046014	2061046014	-	-	2061046014
⚠ 69	VOLTAGE SEL. SW.	2120186006	-	-	-	-
70	CAUTION SHEET	-	-	-	5130364006 (2)	-
71	IMPORTANT LABEL	-	-	-	-	-
72	FUSE LABEL	5130654002 (4A)	-	-	-	-
73	LA APPROVAL MARK	-	5138300004	-	-	-
74	DANGEROUS MARK	-	5138266009 (2)	-	-	-
75	CSA LABEL	-	-	-	-	5138311006
⚠ 76	POWER SWITCH	2129334002	2129534002	-	-	2129534002
⚠ 77	CAPACITORS (µF/400V(AC))	2533063014 (0.0047)	2538010007 (0.01)	-	-	2538010007 (0.01)
78	WOOD BOARD (R)	-	1019026003	-	-	1019026003
79	WOOD BOARD (L)	-	1019027002	-	-	1019027002
80	INDICATION SHEET	-	5130784000	-	-	5130784000
81	PROTECTOR SHEET	-	5040077069	-	-	5040077069
82	FUSE LABEL	5130607019	5130607019	-	-	-
⚠ 83	FUSE (4A)	2061015087	-	-	-	-
101	TAPPING SCREW (S) 3x6 (BLACK)	4737002034 (52)	4737002034 (50)	4737002034 (52)	4737002034 (52)	4737002034 (50)
108	M3 NUT	-	-	4756006008 (2)	4756006008 (2)	-
111	φ3 TOOTHED WASHER	-	-	4753001051 (2)	-	-
112	5T LUG	-	-	-	-	-
113	φ4 TOOTH WASHER	-	-	4753100004 (6)	-	-
114	TAPPING SCREW 4x6 (BLACK)	4734453039 (2)	4734453039	-	-	4734453039
115	TAPPING SCREW 4x20 (BLACK)	-	4737007039 (8)	-	-	4737007039 (8)
116	φ5 WASHER (BLACK)	-	4751006016 (8)	-	-	4751006016 (8)
204	CARTON CASE	5019101050	5019104099	5019101050	5019101050	5019104099
207	CONTROL CARD	-	-	5138295009	5138295009	-
211	CAUTION PAPER	-	-	5130211007	-	-
212	WARRANTY IN ENVELOPE	-	5150349108	-	-	-
213	SAFETY INSTRUCTION	-	5111041102	-	-	-

GOLD VERSION PARTS LIST
(Same as BLACK VERSION except the followings.)

Ref. No.	Part No.	Part Name & Descriptions	Q'ty
34	1139071019	PUSH KNOB (T)	2
35	1139072021	PUSH KNOB (L)	3
36	1449030122	FRONT PANEL ASS'Y	1
37	1139073211	PUSH KNOB (F) ASS'Y	1
38	1469044114	KNOB GUIDE (P) ASS'Y	1
40	1139070117	PUSH KNOB (P)	1
41	1139012017	VR KNOB ASS'Y	1
42	1129013210	KNOB ASS'Y	4
43	1129014112	KNOB ASS'Y	2
44	1029013336	TOP COVER	1
105	4737014006	TAPPING SCREW(S) 4x8	6
204	5019101076	CARTON CASE	1
206	5139111001	COLOR LABEL (GOLD)	2

WIRING DIAGRAM
EA Model (Same as E2 version except the following)

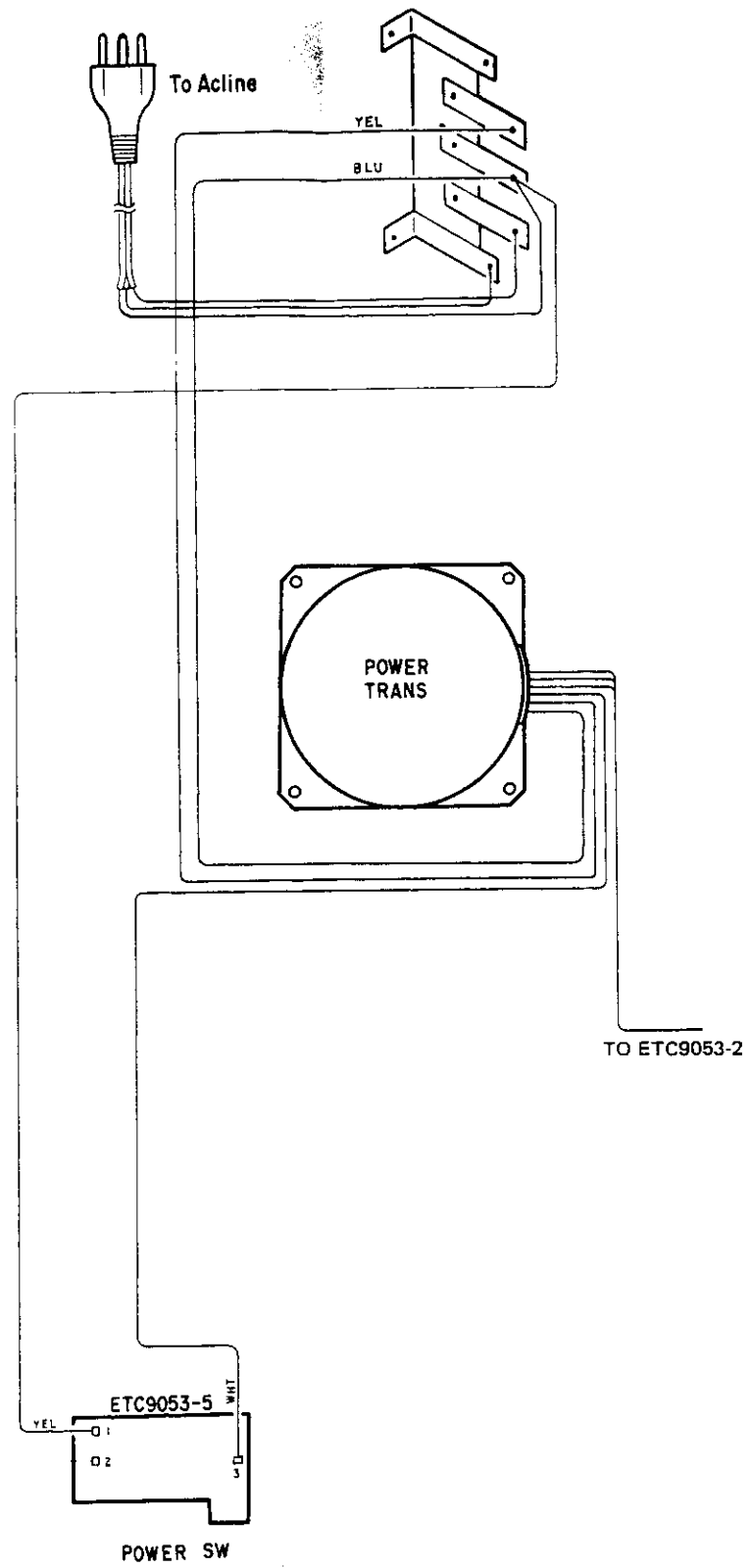

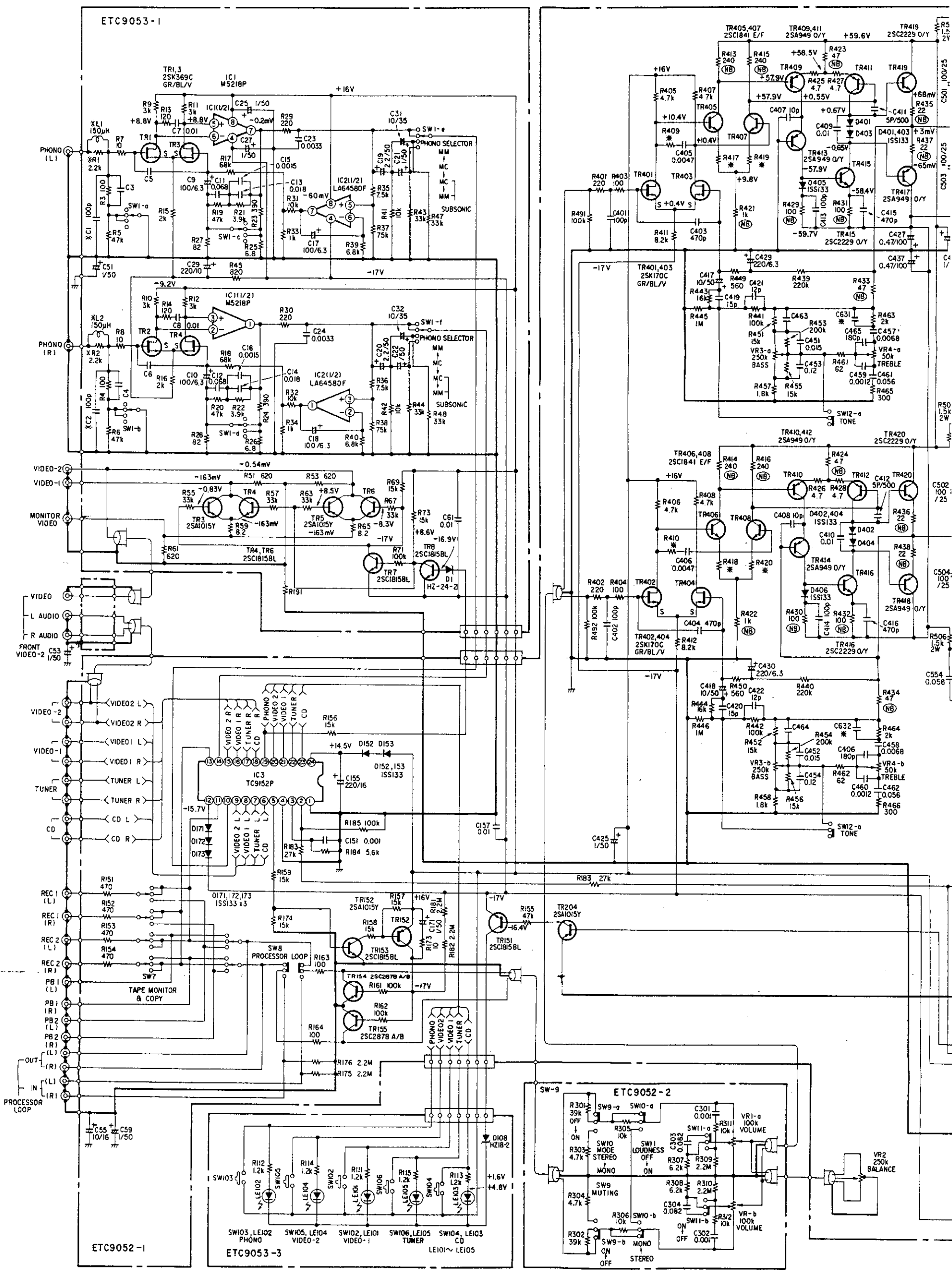

Means important safety item, which must be replaced, when necessary, by a part specified or meeting the specification by the manufacturer.

6 7 8 9 10 11

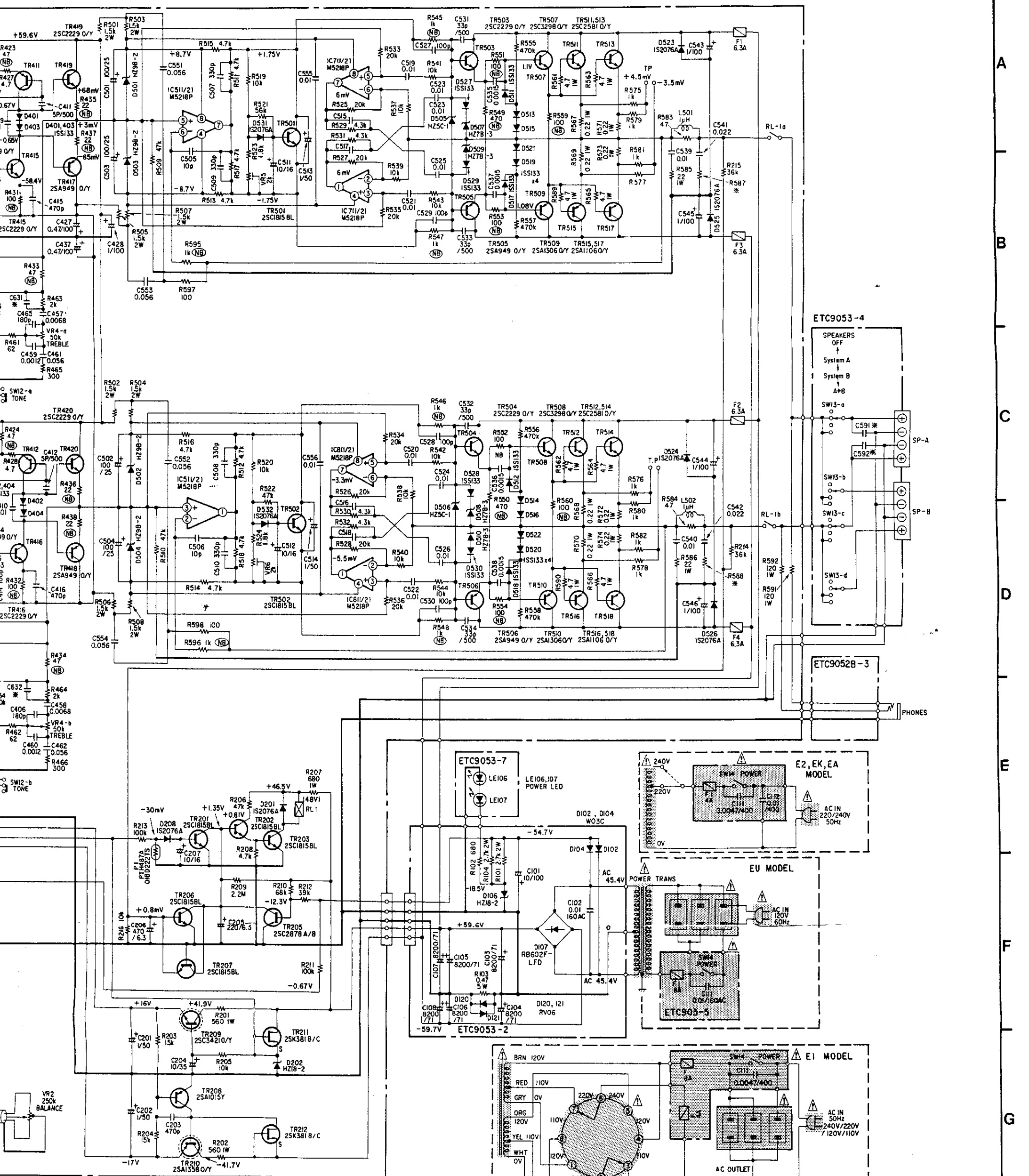

*	LI,2	R1,2	C1,2	C591,592	R409,410	R417~R420	R587,588	C631,632
EU	Not Used	JUMPER	100p	Not Used	330	10	22/1W	Not Used
E2	150µH	2.2k	150p	0.0047µ	100	33	6.8/1W	220p
EK,EA	Not Used	JUMPER	150p	Not Used	330	10	22/1W	Not Used
E1	Not Used	JUMPER	100p	Not Used	330	10	22/1W	Not Used

NOTES:
 ALL RESISTANCE VALUES IN OHM, K = 1,000 OHM, M = 1,000,000 OHM.
 ALL CAPACITANCE VALUES IN MICROFARAD, P = MICRO-MICRO FARAD.
 EVERY VOLTAGES AND CURRENTS IS MEASURED AT NO SIGNAL INPUT CONDITION.
 CIRCUIT AND PARTS ARE SUBJECT TO CHANGE WITHOUT PRIOR NOTICE.