

TEVION

TV-5550VT

MODEL

SERVICE MANUAL

SAFETY INSTRUCTIONS

GENERAL GUIDELINES

1. It is advised to insert an isolation transformer in the AC supply before servicing a hot chassis.
2. Potentials as high as 33KV are present when this receiver is in operation. Operation of the receiver without the rear cover involves the danger of a shock hazard from the receiver power supply. Servicing should not be attempted by any one who is not competent with the precautions necessary when working on the high voltage equipment. Always discharge the anode of the tube.
3. When servicing observe the original lead dress in the high voltage circuits. If a short circuit is found, replace all the parts which have been overheated or damaged by the short circuit.
4. Always use the manufacturer's replacement safety components. The critical safety components marked with Δ on the schematics diagrams should not be replaced by other substitutes. Other substitute may create the electrical shock, fire or other hazards. Take attention to replace the spacers with the originals. Furthermore where a short circuit has occurred, replace those components that indicate evidence of overheating.
5. After servicing, see that all the protective devices such as insulation barriers, insulation papers, shields and isolation R-C combinations are correctly installed.
6. When the receiver is not being used for a long time of period of time, unplug the power cord from the AC outlet.
7. After servicing make the following leakage current checks to prevent the customer from being exposed to shock hazard.

LEAKAGE CURRENT COLD CHECK

1. Unplug the AC cord and connect a jumper between the two prongs of the plug.
2. Turn the receiver's power switch on.
3. Measure the resistance value with an ohmmeter, between the jumpered AC plug and each exposed metallic cabinet part on the receiver, such as screw heads, aerials,

connectors, control shafts etc. When the exposed metallic part a return path to the chassis the reading should be between 4Mohm and the 20Mohm. When the exposed metal does not have a return path to the chassis, the reading must be infinite.

LEAKAGE CURRENT HOT CHECK

1. Plug the AC cord directly in to the AC outlet. Do not use an isolation transformer for this check.
2. Connect a 2Kohm 10W resistor in series with an exposed metallic part on the receiver and an earth, such as a water pipe.
3. Use an AC voltmeter with high impedance to measure the potential across the resistor.
4. Check each exposed metallic part and check the voltage at the each point.
5. Reverse the AC plug at the outlet and repeat each of the above measurements.
6. The potential at the any point should not exceed 1.4 Vrms. In case a measurement is outside the limits specified, there is the possibility of a shock hazard, and the receiver should be repaired and rechecked before it is returned to the customer.

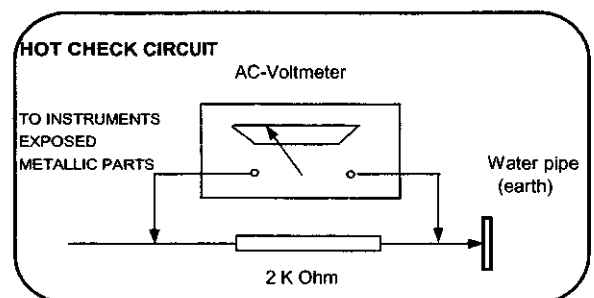

Figure 1

X-RAY RADIATION WARNING

The primary source of X-ray radiation in this receiver is the picture tube. The chassis is specially constructed to limit X-ray radiation. For continued X-ray radiation protection, replace the tube with the same type of the original one.

CAUTION

AFTER REMOVAL OF THE ANODE CAP, DISCHARGE THE ANODE OF THE PICTURE TUBE AND THE ANODE CAP TO THE METAL CHASSIS, CRT SHIELD, OR THE CARBON PAINTED ON THE CRT WITH A HIGH VOLTAGE PROBE AND MULTIMETER (SELECT VDC) AND THEN SHORT CIRCUIT DIRECTLY TO DISCHARGE COMPLETELY.

CONTENTS	PAGE
Safety Instructions	1
Technical Specifications	2
Instructions Manual	3
Block Diagram	12
Pin Voltages of IC's	13
Oscillograms	17
Electrical and Service Adjustments	21
Convergence Adjustments	24
Channel Frequency Tables	26
Part List	30
Circuit Diagrams	Attached

TECHNICAL SPECIFICATIONS

Power source:	220-240V AC, 50-60Hz	
Power consumption (max.):	95 W	20", 21"
Standby power consumption :	4 W	
Aerial impedance :	75Ohm, coaxial type	
Receiving system ¹:	PAL BG PAL SECAM BG PAL SECAM BG DK PAL SECAM BG LL' PAL I	
Receiving channels:	VHF BAND I	CH2-4
	VHF BAND III	CH5-12
	CABLE TV	S1-41
	UHF BAND	CH21-69
Audio outputs :	2 x 7W RMS at %10 THD	
High Voltage :	25 ± 0.5 KV	20", 21"
Focus voltage :	%25.6 ± %38 of EHT	
Grid 2 voltage :	0-1400 V	
Heater voltage :	6.2 ± 0.2 Vrms	
Video/Audio Terminals :	AV1 IN	Video : 1 Vpp,75 Ohm Audio : 0.5 Vrms, >10 Kohm RGB
	AV1OUT	Video : 1 Vpp, 75 Ohm Audio : 0.5 Vrms, <1 Kohm
	AV2 IN (optional)	Video : 1 Vpp,75 Ohm Audio : 0.5 Vrms, >10 Kohm
	AV2 OUT (optional)	Video : 1 Vpp, 75 Ohm Audio : 0.5 Vrms, <1 Kohm
	AV2 IN (RCA, optional)	Video : 1 Vpp, 75 Ohm Audio : 0.5 Vrms, >10 Kohm
Operating temperature :	0-45 Degrees	
Safety :	IEC 65 /BS P2N	
X-Ray radiation :	ACC. IEC 65/BS P2N	

¹ : TV set is produced to receive "one" of these colour and sound systems.

SPECIAL FEATURES :

- Your TV can receive stereo channels directly.
- Automatic channel selection
- 100 Programme Memory
- Available for Cable Channels (A decoder maybe required)
- Manual Fine Tuning
- Child Lock
- Return to the last channel viewed (SWAP)
- Spatial Sound effect
- 16:9 picture format
- S-VHS terminal (optional)
- External Loudspeakers (optional)
- Normalisation system to recall the setting in memory after the colour, contrast, brightness setting have been changed.
- Picture adjustment using one button
- Sound adjustment using one button.
- Smart Control
- Equalizer Sound Setup
- Automatic Volume Limiting
- Your TV set is equipped with an On-Screen Display system. This system enables the user to see the function on-screen and to control them efficiently.
- Infrared Remote Control
- Virtual Dolby Surround (optional)
- Your TV will automatically switch off if it's been programmed from 5 to 120 minutes, and it will automatically switch to Stand by five minutes after a channel ceases to transmit.
- Menu with 8 languages
- Stereo headphone (optional)
- Scart Socket video cassette recorder, satellite receiver, video disc player, TV games or a home computer can be connected to this AV socket with an appropriate connecting cable.
- Naming the channels

REMOTE CONTROL:

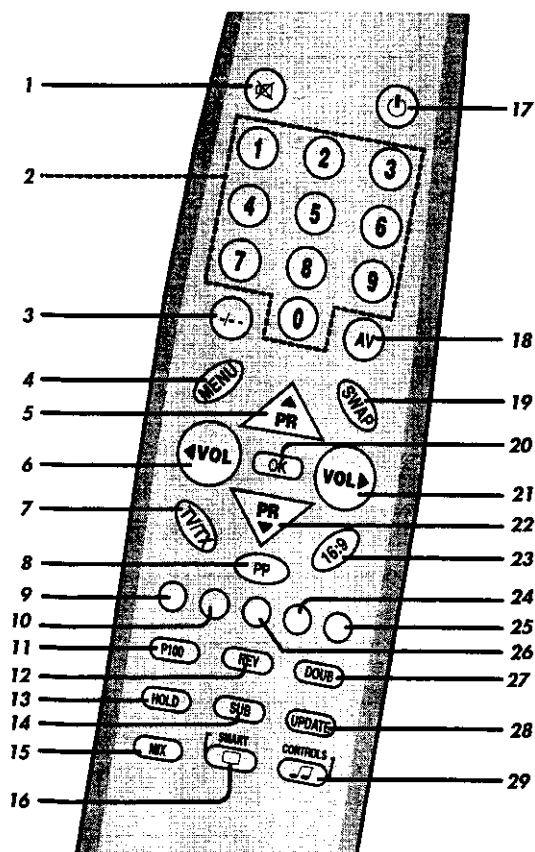

1. MUTE button
2. Ten Key Programme button
3. Two digit programme button (-/--)
4. Menu button
5. Programme Up button
6. Volume decrease button
7. Teletext selection button
8. PP
9. Red Fasttext button (Sound menu selection)
10. Green Fasttext button (Picture menu selection)
11. P100/Index button
12. Reveal button (REV)
13. Hold button
14. Clock / Sub-page button
15. Mix button
16. Picture adjustment selection button (Smart Control)
17. STAND BY button
18. AV button
19. SWAP button
20. OK button
21. Volume increase button
22. Program down button
23. 16:9 picture format button
24. Blue Fasttext button (Setup menu selection)
25. Purple button (Features menu selection)
26. Yellow Fasttext button (Programme Edit menu selection)
27. Enlarge button (DOUBLE)
28. Update button
29. Equalizer selection button (Smart Control)

Pin Connections For Scart Socket 1

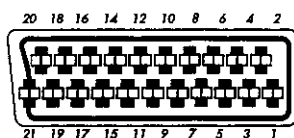

- | | |
|-----------------------------|-------------------------|
| 1- Audio output Right | 11- RGB input, Green |
| 2- Audio input Right | 12- |
| 3- Audio output Left (Mono) | 13- Red ground |
| 4- Audio ground | 14- Ground |
| 5- Blue ground | 15- RGB input, Red |
| 6- Audio input Left (Mono) | 16- Blanking Signal |
| 7- RGB input, Blue | 17- Video output ground |
| 8- Switching voltage | 18- Video input ground |
| 9- Green ground | 19- Video output |
| 10- | 20- Video input |
| | 21- Screening |

Pin Connections For Scart Socket 2 (Optional)

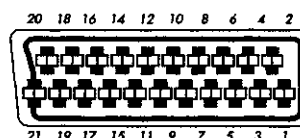

- | | |
|-----------------------------|-------------------------|
| 1- Audio output Right | 11- |
| 2- Audio input Right | 12- |
| 3- Audio output Left (Mono) | 13- Red ground |
| 4- Audio ground | 14- Ground |
| 5- Blue ground | 15- |
| 6- Audio input Left (Mono) | 16- |
| 7- | 17- Video output ground |
| 8- Switching voltage | 18- Video input ground |
| 9- Green ground | 19- Video output |
| 10- | 20- Video input |
| | 21- Screening |

Note 1 : You can record the broadcast from the equipment connected to the scart socket 1 to the equipment connected to the scart socket 2 by selecting AV 1 mode. But you can not watch the normal TV broadcast.

Note 2 : You can get a better picture if you connect your TV a S-VHS equipment through the scart socket 2 by selecting AV 2-S mode.

Note 3 : You can also get picture through the scart sockets by connecting a NTSC supported equipment. To perform the colour adjustments select TINT in the PICTURE menu by using PR button. Then adjust the TINT using the <VOL/VOL> buttons.

External equipment connection through the AV terminals (optional)

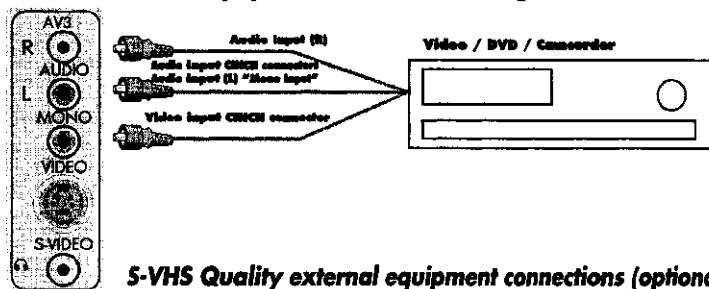

You can connect external equipment such as Video, DVD, Camcorder or Audio equipment through the RCA type connectors to your TV. Connect the equipment to VIDEO Input and Audio Input (L) for mono equipment as shown on the left side picture. Also connect Audio R for stereo equipment. Then push the "AV" button four times and select the "AV3" mode.

S-VHS Quality external equipment connections (optional)

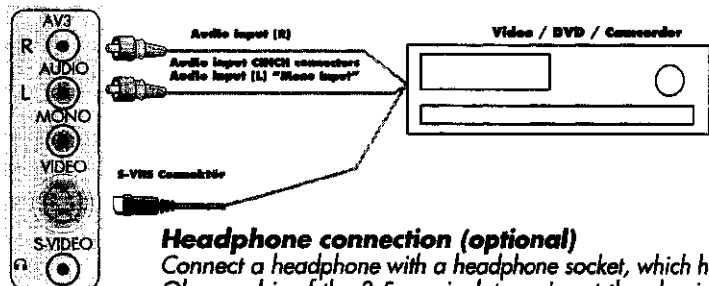

NOTE: If the input is mono, select the DUAL I option in the SOUND TYPE row of the SOUND menu.

You can also connect S-VHS Quality equipment such as VCR and camcorder. Connect the equipment to S-VHS connector, Audio input (R) and Audio input (L) as shown on the left side picture. Push the "AV" button on the remote control five times and select the "AV3-S" mode.

Headphone connection (optional)

Connect a headphone with a headphone socket, which has an impedance of between 8 and 600 Ohm and is of the 3,5 mm jack type. Insert the plug into the headphone socket. In the Sound menu select Headphone to adjust the sound adjustments for headphone.

External loudspeakers (optional)

You can replace the left and right internal loudspeakers of your set by two extra loudspeakers, 8 Ohm each. Connect the loudspeakers to the connector clips at the back of the TV. Push the connector clip down and insert the ends of the wires into the openings: the negative wires to the black connector clips, the positive wires (the one with a black line) to the red connector clips. Do not insert the wires too far. Connect the front left loudspeaker to L and the front right loudspeaker to R. Put the loudspeaker switch on the back in the EXT position. The internal right and left loudspeakers of your TV are now switched off.

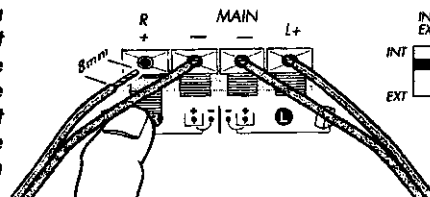

4. OPERATING YOUR TV

STANDBY



By pushing the red **STANDBY** button on the upper right hand side of your remote control, the television will switch into standby. To turn your TV on again you can press any of the programme buttons on the remote control.

ATTENTION!
Always switch the television off by the TV ON/OFF switch when leaving the TV unattended.

MUTE

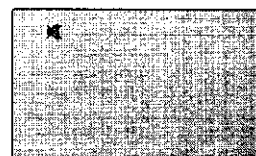
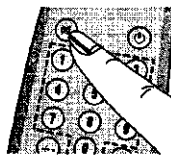

If you want to mute the sound of your TV press the "X" button. A red symbol "X" will appear on the screen. Pressing the "X" again will restore the sound.

When your TV is in MUTE mode if you press the ◀VOL button the volume will decrease without restoring the sound.

But if you press the VOL▶ button the sound will be restored and the volume will increase.

INFO BUTTON

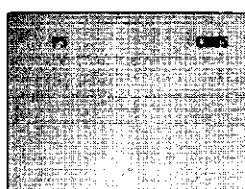
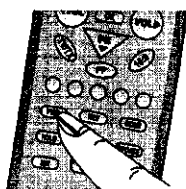

By pressing the "P100" button the programme number and programme name will appear on the screen. This will disappear automatically after a few seconds.

MAIN MENU

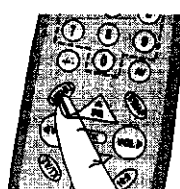

Press menu button the Main Menu will appear. You can select any sub-menu using PR▲/PR▼ buttons and then pressing "OK" button.

TUNING and MEMORY

You can tune the TV either automatically or manually.

Automatic tuning and memory :

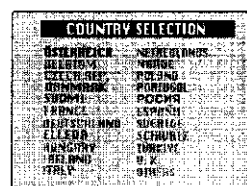
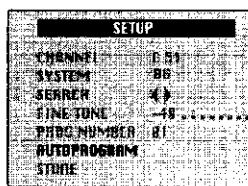
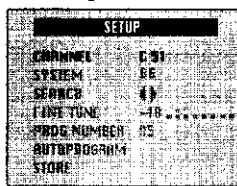
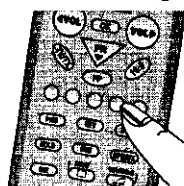

- Press the blue fasttext button on your remote control.
- Setup menu will appear on the screen.
- Select Autoprogramme using PR▼ button.
- Press OK. The Country Selection menu will now appear on the screen.

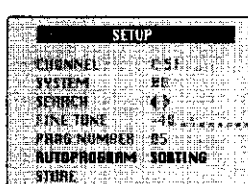
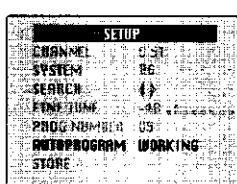
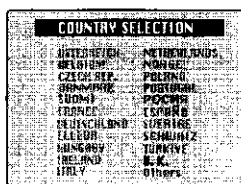

- Select the desired Country using the PR▲/PR▼ or ◀VOL/VOL▶ buttons.
 - Press OK. Your TV will start to search for and store programmes. Meanwhile AUTOPROGRAM WORKING sign will flash on and off on the AUTOPROGRAM row. Once AUTOPROGRAM is completed the TV will automatically arrange the programmes into order.
 - To stop this process press Menu button. Your TV will sort all stored programmes. During this period AUTOPROGRAM SORTING will appear in SETUP mode.
- Note: If auto sort fails to arrange the programmes in the required sequence please refer to programme edit on page 20.

Manual tuning and memory:

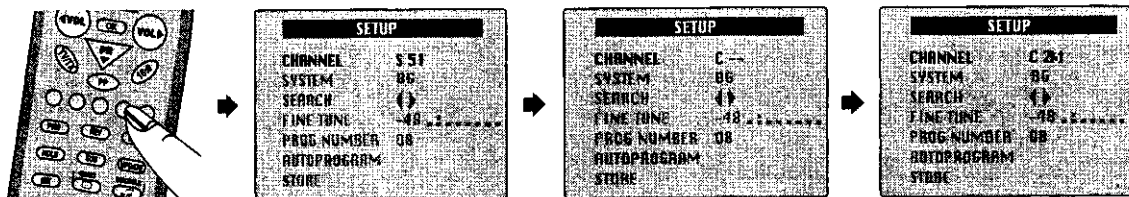

Tuning with known channel numbers:

- Press the blue fastext button on your remote control.
- SETUP menu will appear on the screen.
- Press OK button then using **PR▲/PR▼** and **◀VOL/VOL▶** buttons select S for cable channels and C for terrestrial broadcast.

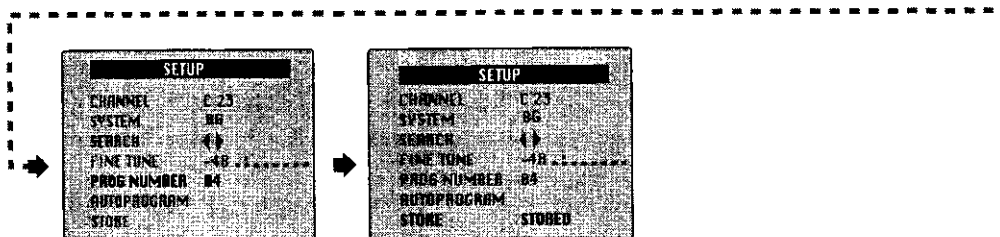

- Press **VOL▶** button to select the channel row then enter the channel number using the numeric keys on the remote control.
- Press OK, then select PROG NUMBER using the **PR▼** button. Enter the programme number for the channel you have tuned to (ie 01 for BBC1) using the numeric keys on the remote control.
- Select STORE using **PR▼** button then press OK to store.

Tuning with unknown channel numbers:

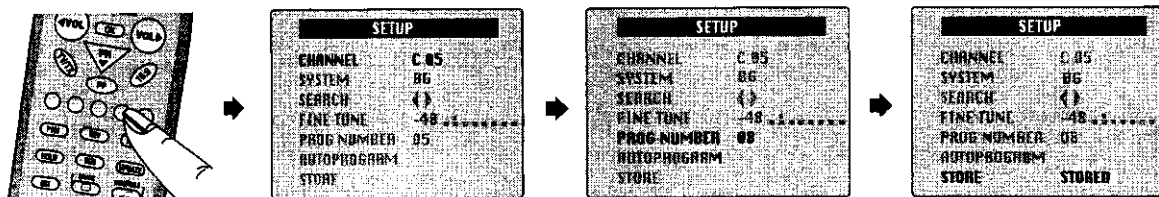

- Press blue button to enter SETUP menu.
- Scan channel numbers using **◀VOL/VOL▶** buttons.
- If the required station is found select PROG NUMBER using **PR▼** button.
- Enter the desired programme number using numeric key pad or **◀VOL/VOL▶** buttons.
- Select STORE using the **PR▼** button then press OK to store.

Tuning with SEARCH option :

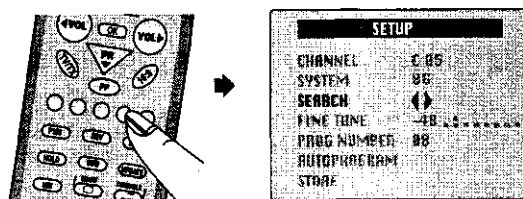

- Press blue button to enter SETUP menu.
- Select SEARCH using **PR▼** button and start tuning using **◀VOL/VOL▶** buttons.
- The TV will tune until a TV station is found.
- If you want to store this station select PROG NUMBER using the **PR▼** button. Enter the desired programme number then select STORE using the **PR▼** button. Press OK to store

Manual Fine Tune:

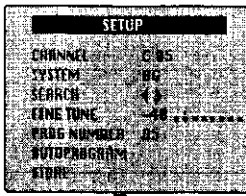

It may now be necessary to fine tune your TV to optimise reception, if so proceed as follows

- In the **SETUP** menu select **FINE TUNE** using **PRV** button.
- Use the **◀VOL/VOL▶** buttons to obtain the best optimum setting.
- Select **STORE** using the **PRV** button. Then press **OK** to store.

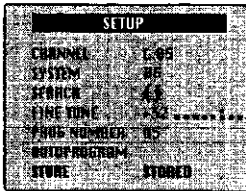
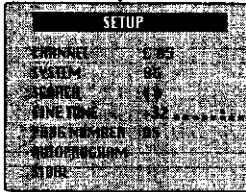

Programme Recall:

1. You can recall any programme by pressing the **PR▲/PR▼** buttons or numeric key pad. When the desired programme has two digits first press **-/--** button and then two digits of the programme.

2. By pressing **SWAP** button on your remote control you can select the last viewed channel.

3. Pressing **OK** button on your remote control a small programme menu will appear on the screen.

You can also select the desired programme from this menu. In this menu hidden programmes will be coloured red and the programmes including Child Lock will be blue coloured. Using **PR▲/PR▼** buttons select the desired programme then press **OK** to watch that channel. This menu will disappear automatically. You can also use **TV/TX** button to exit the menu

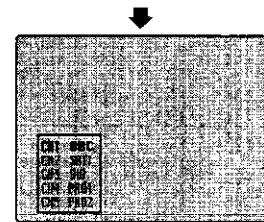

SOUND PRESETS

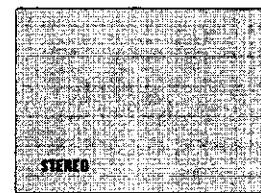
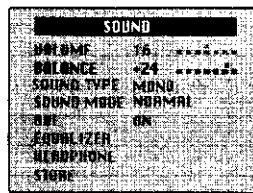
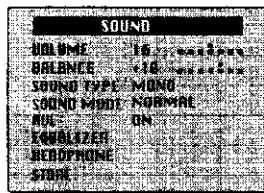
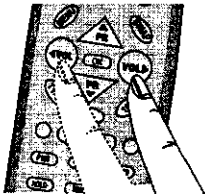

- By pressing the **◀VOL** and **VOL▶** buttons on your remote or by using the volume + and volume - on the front panel you can change the volume level of your TV.
- Press red button on your remote control to enter the **SOUND** menu.
- You can perform other sound adjustments with this menu. Select **BALANCE** using the **PRV** button. Then use **◀VOL** and **VOL▶** buttons to adjust the volume levels of the left and right speakers individually.
- If the channel is stereo **STEREO** will appear on the screen.
- Select **SOUND TYPE** using **PRV** then press **◀VOL** or **VOL▶** buttons for **DUAL I** or **DUAL II** selection.

SOUND MODE

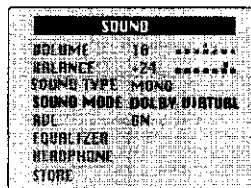
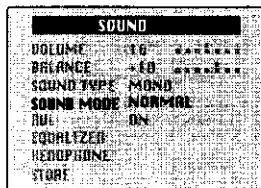
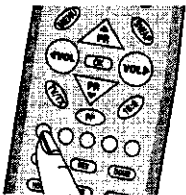

- You can give spatial and different sound effects to the sound quality of your TV.
- Select **SOUND MODE** line by pressing the **PRV** button and change the **SOUND MODE** by pressing **◀VOL** or **VOL▶** buttons between **NORMAL**, **SPATIAL** and **DOLBY VIRTUAL**.

VIRTUAL DOLBY (optional)

Virtual Surround Dolby is based on Dolby Pro Logic decoding for the reproduction of the Left, Right, Centre and Virtual Surround sound channels using two loudspeakers.

@ "DOLBY", "VIRTUAL DOLBY SURROUND" and  the double-D symbol are trademarks of Dolby Laboratories Licensing Corporation.

NOTE: To get the surround effects in **VIRTUAL DOLBY** mode, you must apply a **DOLBY PRO LOGIC** coded input to the TV set. If it's not, select the **NORMAL** or **SPATIAL** modes of **SOUND TYPE** in the **SOUND** menu.

**VL
Automatic Volume Limiting) :**

In the SOUND menu, select AVL by pressing PR button. TV transmitters have different sound modulation. When switching from one programme to other some annoying sound level differences can be noticed. To avoid this, select ON by pressing VOL or VOL button.

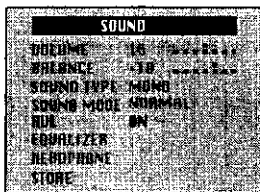

EQUALIZER:

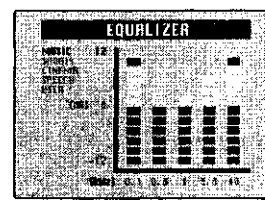
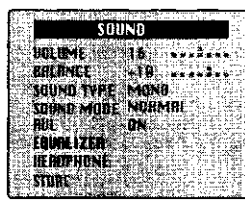
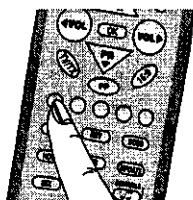

- Press the RED button on your remote control.
- SOUND menu will appear on the screen.
- Select EQUALIZER using the PR button then press OK button.
- Equalizer adjustment menu will appear on the screen.
- By pressing PR/PR buttons, you can select any adjustment according to the broadcast. Adjustments for the Music, Sports, Cinema and Speech can not be changed. But in the USER mode you can select the desired adjustments yourself.

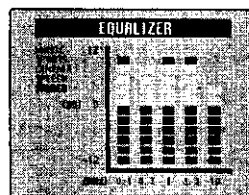
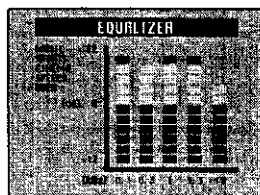

- To do this, select USER using the PR button then press OK.
 - Adjust the level of each frequency by pressing VOL or VOL and PR/PR buttons.
 - To store these settings select STORE using the PR button, then press OK.
 - To exit the menu press RED button.
- NOTE:** You can recall preset and user equalizer settings by pressing button on the remote control as well.
- Each time you press this button, Equalizer modes will appear on the lower left side of the screen subsequently.

HEADPHONE :

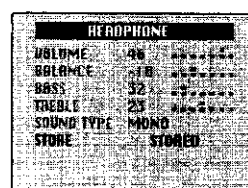
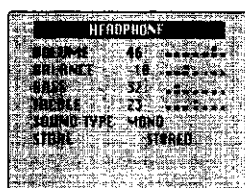
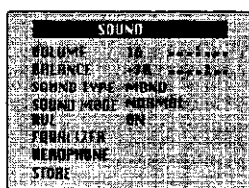
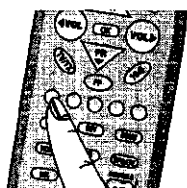

- Press red button on the remote control.
- SOUND menu will appear on the screen.
- Select HEADPHONE using PR button. Then press OK.
- Headphone menu will appear on the screen. If you insert a 3,5 mm, stereo headphone to the headphone socket of your TV you can use these features.
- Select any adjustment using PR/PR buttons then adjust to the desired level using VOL and VOL buttons.
- To store these settings select STORE using the PR button, then press OK.

PICTURE ADJUSTMENTS:

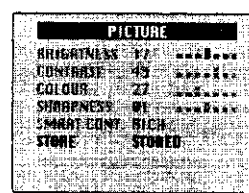
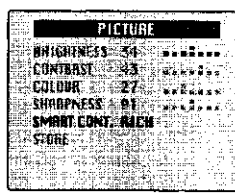
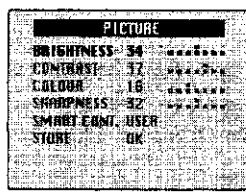
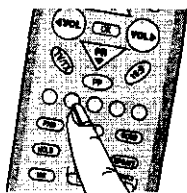

- Press green button on the remote control.
 - PICTURE menu will appear on the screen.
 - Using PR/PR for adjustment selection and VOL/VOL buttons for desired levels you can make the adjustments. While doing this USER will appear in the SMART CONT row. These are the personal presets. There are also special adjustments called SOFT, NATURAL and RICH. These adjustments can not be changed by the user.
 - To select one of these select SMART CONT. using PR/PR then press VOL/VOL buttons.
 - In order to store the changes select STORE using the PR button. Then press OK button on your remote control.
- NOTE:** You can also activate the preset picture settings by pressing " " button on your remote control without entering the picture menu.

OTHER FEATURES:

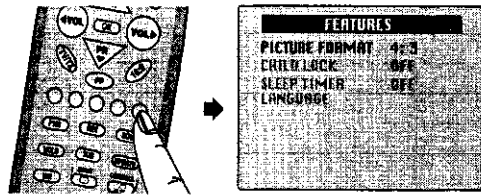

- Press the purple button on your remote control.
- FEATURES menu will appear on the screen.

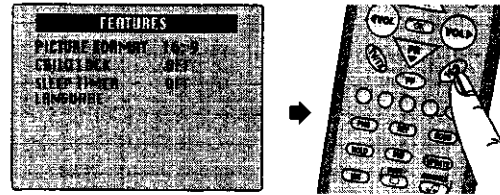

PICTURE FORMAT:

The picture format of your TV set is 4:3. If you want to change picture format from 4:3 to 16:9;

- Select PICTURE FORMAT using **PR** button then press **◀VOL/VOL▶** buttons.

NOTE: Also you can use the Picture Format (16:9) button on your remote control to change the format from 4:3 to 16:9 directly.

- "16:9" sign will appear on the lower left side of the screen for a short while.

CHILD LOCK:

You can lock any channel using this feature.

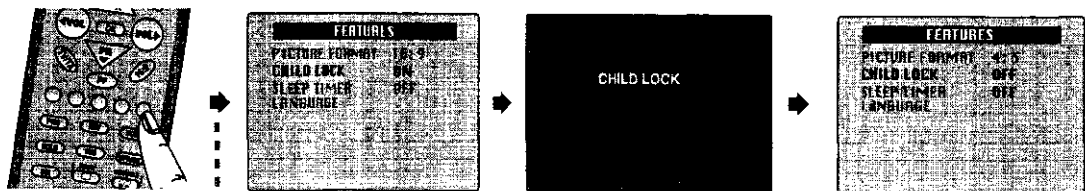

- Select the channel that you want to lock then press purple button.
- Then select CHILD LOCK using **PR** button.
- Using **◀VOL/VOL▶** buttons select ON.
- Press TV/TX to exit. Child Lock will appear on the screen. When you select this channel again you will see this message on the screen again.
- To cancel Child Lock enter FEATURES menu.
- Select CHILD LOCK using **PR** button.
- Then Select OFF using **◀VOL/VOL▶** buttons.

MENU LANGUAGE:

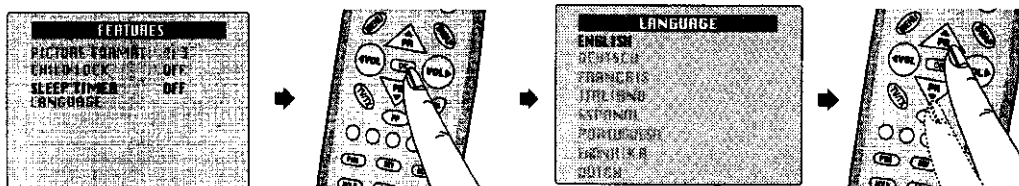

- Press the purple button on your remote control. FEATURES menu will appear on the screen.
- Press **PR** button to select LANGUAGE then press OK.
- LANGUAGE menu will appear on the screen. Press the **PR**/**PR** buttons to select your desired language.
- Press OK button. All the on screen displays will appear in the selected language.
- Press the TV/TX button to return to normal TV viewing.

PROGRAMME EDIT

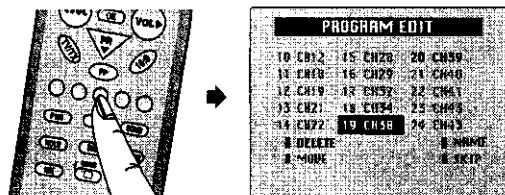

Deleting a programme:

- Press **YELLOW** button on your remote control.
- **PROGRAM EDIT** menu will appear on the screen.
- Select a programme to be deleted with the **PR▲/PR▼** or **◀VOL/VOL▶** buttons.
- Press the **PURPLE** button on the remote control.
- The selected programme is deleted, all the following programmes are shifted up by one position.

Moving a programme:

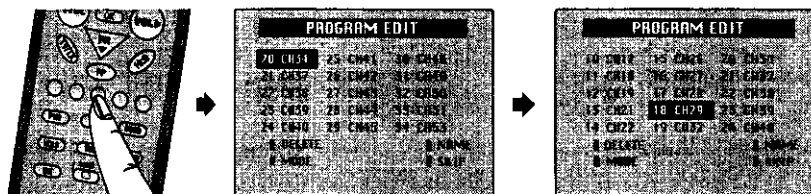

- Press the **YELLOW** button on the remote control.
- **PROGRAM EDIT** menu will appear on the screen.
- Select a programme to be moved with the **PR▲/PR▼** or **◀VOL/VOL▶** buttons.
- Press the **GREEN** button on the remote control. The selected programme number and name will turn to green.
- Select the programme number that you want to move to by using the **PR▲/PR▼** or **◀VOL/VOL▶** buttons.
- Then press the **GREEN** button. The programme has now been stored in the new location.

NOTE: All the following programmes will be shifted down by one place.

Naming a programme:

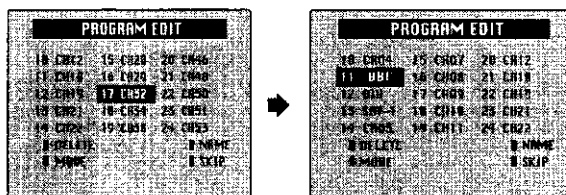

- Enter **PROGRAM EDIT** menu as described before.
- Select the programme to be named with the **PR▲/PR▼** or **◀VOL/VOL▶** buttons.
- Press the **blue** button on the remote control. The program number and name digits turn to blue.
- To change the letters use the **PR▲/PR▼** buttons.
- To select the next character use **VOL▶** button.
- After entering all characters press blue button to store.

Skipping a stored programme:

When a programme number is skipped it means that you will be unable to select it using the **PR▲/PR▼** button during normal TV viewing.

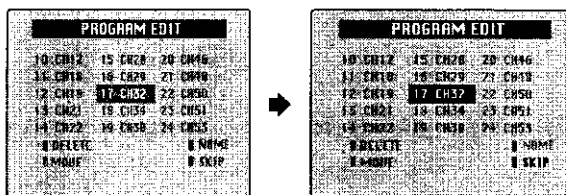

- Enter **PROGRAM EDIT** menu as described before.
- Select the programme to be skipped with the **PR▲/PR▼** or **◀VOL/VOL▶** buttons.
- Press the **red** button. The skipped programme turns to red.
- If you want to select the skipped programme, directly enter the programme number using the **NUMBER** buttons.
- If you want to cancel this function, enter **PROGRAM EDIT** menu and select the skipped programme and press the red button.

TELETEXT

Teletext is an information and news service available on several programme channels. It enables you to get up to the minute information on such diverse subjects as international events, holidays, shopping or even the local weather for your area.

The signal for teletext is combined with the transmitted signal which provides you with your programmes. To get best results for both, we would recommend that an outdoor aerial is used. Poor reception will cause errors in the text displayed on the screen, ie words missing from sentences or letters missing from words. Even with good reception some errors can occur, however, these should correct themselves within a few seconds. Such errors or word corruptions usually indicate a reception fault rather than a fault with your television. If the channel has no Teletext "NO TEXT" sign will appear on the screen and will disappear automatically after 5 seconds.

Using the TELETEXT function

Press the TV/TX button on the handset. This will change the picture mode to TELETEXT. Ensure that the channel you are on broadcasts Teletext. When the TV/TX button is pressed it will revert back to picture mode.

Page Selection

Enter the three digit page number of your choice using the programme key buttons. The selected page number will appear in the top left of the header page. If you want to select the next or the previous page use the PR ▲ or PR ▼ buttons.

SUB (Sub page button)

Some text pages have extension or sub-pages containing additional information. You can press SUB button to select the sub-pages; on the first line "S*****" will be displayed.

These can be viewed by keying in the four digit number using the numeric keypad. Press the SUB button to return to the main-page.

Clock function

A real time clock is transmitted constantly whilst the channel is being broadcast which can be displayed. You can press the SUB button to see the real time while watching the TV channel.

DOUB (Enlarge button)

This will expand the top and bottom of the page to double height when repeatedly pressed. If you press the DOUB button for the third time you can return to normal page size.

REV (Reveal button)

Sometimes a teletext page contains concealed information, for example, in a quiz or puzzle. To Display the concealed information press this button.

HOLD (Stop button)

This button allows you to "HOLD" certain pages of Teletext information if a teletext page consists of 2 or more sub pages and shows them in a cycle. Press again to cancel "HOLD" and to proceed to the next page.

P100 (Index / Info button)

Press this button to select the Index page.

MIX

With Teletext displayed press this button once to mix the text and picture information, press again to return to full teletext page. While you are using the "MIX" function, you can return to the TV mode only by pressing the "TV/TX" button.

UPDATE

While the TV is searching the selected page press this button once to enter update mode. This allows you to clear the text and return to a TV programme. When the page is located the TV will display the page number it is searching for. When the page is located press the UPDATE button again to return to the page you required.

Whenever an updated newflash is available, the updated news item will appear over the normal TV programme. Press the UPDATE button twice to make the news information disappear.

To return the normal TV picture press the TV/TX button.

Fastext

Colour coded buttons are employed for FASTEXT. When teletext is selected several subject titles will appear at the bottom in coloured forms. By pressing one of the four colour coded buttons you will go directly to that particular page without having to select the page using the numeric pad.

Toptext (Optional)

This mode includes menu followed index pages to select the teletext pages easier. You can use two different ways to use this mode:

a- Press the INDEX button (P100) and enter the toptext index page.

b- With the coloured subject titles or with the page numbers of them, which appear at the bottom of each teletext pages.

On the MENU title of a toptext index page appear the subject titles. Press the RED or BLUE button to select a particular subject title. Press the GREEN button to select this page. You can select the next and previous pages by pressing the RED and GREEN button.

The YELLOW title includes the next sub-title and the BLUE title includes the next main-title pages. By pressing one of these colour coded buttons you will go directly to that particular page without having to select the page using the numeric pad.

You can also select directly the teletext pages by using the numeric pad on the TOPTTEXT mode.

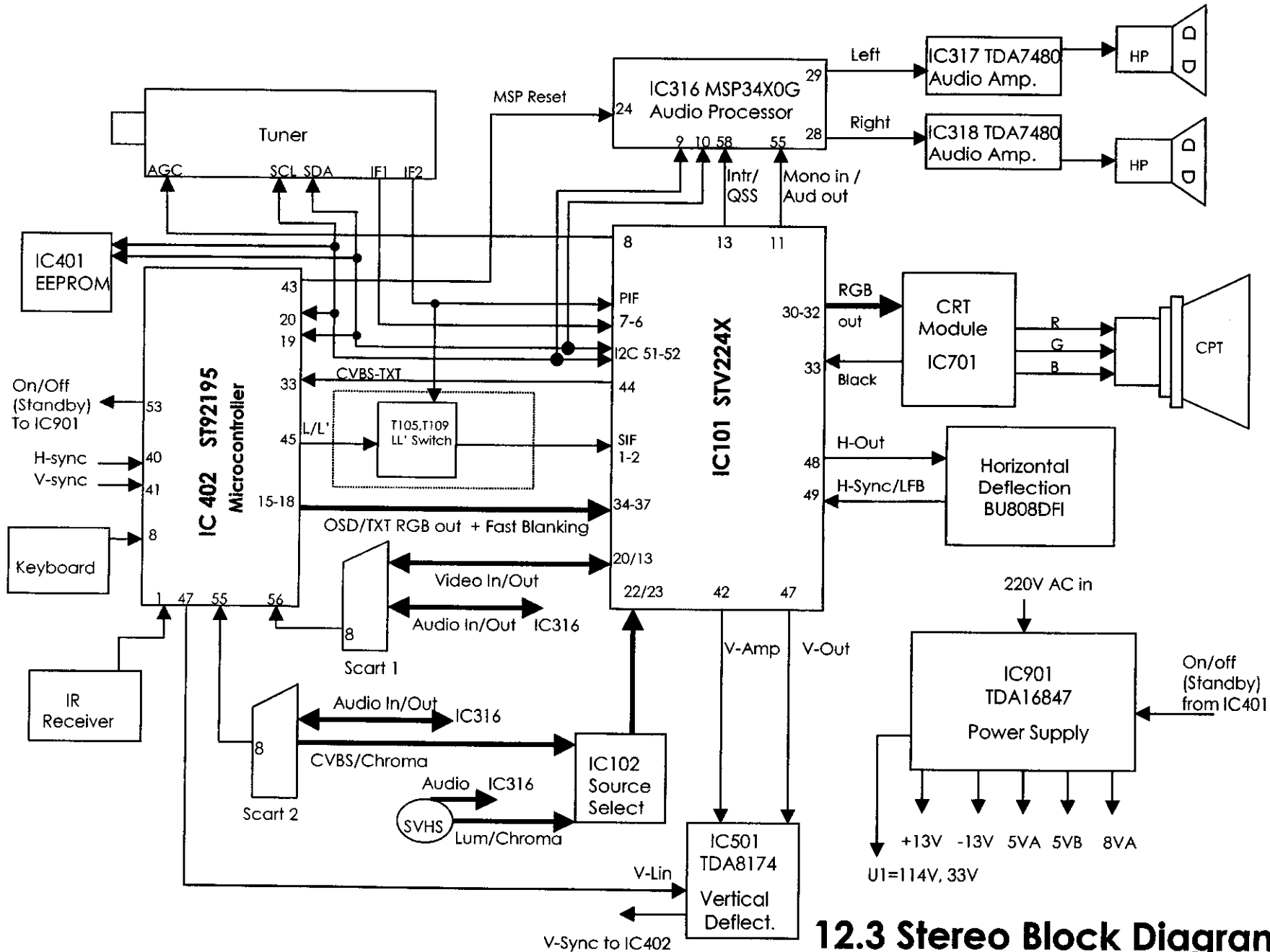

12.3 Stereo Block Diagram

PIN VOLTAGES OF IC'S

IC101 (STV2246)					
BUS CONTROLLED MULTISTANDARD ONE CHIP TV PROCESSOR					
Pin	Connection	V DC (*)	Pin	Connection	V DC (*)
1	Sound IF Input 1	1.0	29	Not connected	3.9
2	Sound IF Input 2	1.0	30	Blue Output	2.3
3	AGC SIF Capacitor	0.1	31	Green Output	2.2
4	IF Voltage Reference Filtering	3.2	32	Red Output	2.3
5	AGC PIF Capacitor	0.1	33	Cathode Current Measurement Input	4.2
6	Picture IF Input 1	2.5	34	OSD Blue Input	4.7
7	Picture IF Input 2	2.5	35	OSD Green Input	4.8
8	AGC Tuner Output	4.6	36	OSD Red Input	4.7
9	IF PLL Filter	1.2	37	OSD Fast Blanking	0.2
10	IF Ground	0.0	38	Cloche Filter Tuning Capacitor	0.1
11	AM/FM Mono Sound Output	4.2	39	3.5X MHz Crystal	0.4
12	5 V IF Supply	5.1	40	4.43 MHz Crystal	-
13	Internal CVBS Output	3.2	41	Chroma PLL Filter	-
14	External Audio Input	2.5	42	Vertical Amplitude DAC Output	4.0
15	LC Input 1	4.0	43	Chroma/Scanning Ground	0.0
16	LC Input 2	4.0	44	Second Video Switch Output	4.1
17	Video/Luma Supply Voltage (8 V)	8.1	45	Chroma/Scanning Power Supply (8V)	8.1
18	Internal Video Input	3.7	46	Beam Current Limiter Control Voltage and Safety Input (XRAY)	6.8
19	Video/Luma Ground	0.0	47	Vertical Output Pulse	4.0
20	External Video Input	3.2	48	Horizontal Output Pulse	1.4
21	Black Stretch Capacitor	2.8	49	Line Flyback Input and Super-sandcastle Output	0.7
22	Y/CVBSIN3 Y(SVHS) or CVBS3 External Input	3.2	50	Scanning PLL Filter	4.1
23	Chroma (SVHS) Input	1.8	51	SCL I2C Bus Clock Input	see osc.
24	Automatic RGB Peak Regulation	5.0	52	SDA I2C Bus Data Input	see osc.
25	External Blue Input	2.5	53	Digital Supply Voltage (5 V)	5.2
26	External Green Input	1.7	54	Digital Ground	0.0
27	External Red Input	2.5	55	Main Audio Output	4.0
28	External Fast Blanking Input	0.0	56	FM Demodulation Capacitor	1.5

IC316 (MSP 34XXG)- MULTI STANDARD SOUND PROCESSOR

Pin	Connection	V DC	Pin	Connection	V DC
1	Not connected	2.3	33	Scart 2 sound output (R)	3.7
2	Gnd	0.0	34	Scart 2 sound output (L)	3.7
3	Gnd	0.0	35	Reference analog ground	0.0
4	Digital control input/output	0.0	36	Scart 1 sound output (R)	3.7
5	Digital control input/output	0.0	37	Scart 1 sound output (L)	3.7
6	Gnd	0.0	38	Volume capacitor Headphone	7.1
7	Standby (in normal operation it must be high)	4.9	39	Analog Supply High Voltage (8V)	8.0
8	Not connected	4.9	40	Volume capacitor Speaker	7.1
9	SCL	see osc.	41	Ground for Analog Power Supply High Voltage	0.0
10	SDA	see osc.	42	Internal Analog Reference Voltage	3.7
11	Not connected	0.5	43	Scart 4 input (L)	3.7
12	Not connected	0.5	44	Scart 4 input (R)	3.7
13	Not connected	0.5	45	Analog Shield Ground	0.0
14	Not connected	0.5	46	CINCH - sound input (L)	3.7
15	Not connected	0.5	47	CINCH - sound input (R)	3.7
16	Not connected	0.5	48	Analog Shield Ground	0.0
17	ADR Bus Clock Output	0.5	49	Scart 2 sound input (L)	3.7
18	Digital Circuitry Supply Voltage	4.9	50	Scart 2 sound input (R)	3.7
19	Digital Circuitry Supply Ground	0.0	51	Analog Shield Ground	0.0
20	Not connected	0.5	52	Scart sound 1 input (R)	3.7
21	Not connected (Ground)	0.0	53	Scart 1 sound input (L)	3.7
22	Not connected (Ground)	0.0	54	A/D converter ref. Voltage	2.5
23	Not connected (Ground)	0.0	55	Mono sound input	3.7
24	MSP RESET input	5.1	56	Ground for Analog Power Supply Voltage	0.0
25	Headphone sound output (R)	0.1	57	Analog Power Supply Voltage (5V)	4.9
26	Headphone sound output (L)	0.1	58	IF input 1	1.5
27	Reference analog ground	0.0	59	IF Common reference for IF IN1/IN2	1.5
28	Speaker output (R)	0.1-2.1	60	IF input 2	0.0
29	Speaker output (L)	0.1-2.1	61	Factory test mode enable (ground)	0.0
30	Not connected	0.1-2.1	62	Crystal oss. input	2.3
31	Not connected	0.1-2.1	63	Crystal oss. output	2.3
32	Not connected	0.1-2.1	64	Not connected (Ground)	0.0

IC317, IC318 (TDA7480) Audio Output IC

Pin	Connection	V DC	Pin	Connection	V DC
1	Negative supply (-13V)	-13.5	11	Input	0.0
2	Negative supply (-13V)	-13.5	12	Standby / mute control pin	5.1 (0.4)
3	Negative supply (-13V)	-13.5	13	Not connected	0.0
4	Output (Pulse width modulated)	0.0	14	Positive signal supply	13.0
5	Built-in Bootstrap diode anode	-2.6	15	10V internal regulator	-2.6
6	Built-in Bootstrap capacitor	10.0	16	Positive power supply (+13V)	13.0
7	Not connected	0.0	17	Negative supply (-13V)	-13.5
8	Feedback integrating capacitance	0.0	18	Negative supply (-13V)	-13.5
9	Setting frequency resistor	-11.6	19	Negative supply (-13V)	-13.5
10	Signal ground	0.0	20	Negative supply (-13V)	-13.5

**IC402 (ST92195B)
MICRO CONTROLLER WITH OSD AND TELETEXT**

Pin	Connection	V DC (*)	Pin	Connection	V DC (*)
1	Infra red input	4.9	29	Analog pin for TXT	2.0
2	Reset	4.3	30	Not connected	1.0
3	Not connected	0.0	31	Analog power supply for PLL (5V)	4.9
4	Not connected	0.0	32	Not connected	4.8
5	Not connected	0.0	33	CVBS input for TXT	0.5
6	Not connected	0.0	34	CVBS input for TXT	1.7
7	Not connected	0.0	35	Analog circuit ground	0.0
8	Local keyboard input	4.9	36	Digital circuit ground	0.0
9	Not connected	0.0	37	Analog pin for OSD	0.0
10	Not connected	0.0	38	Analog pin for OSD	1.9
11	Not connected	0.0	39	Analog power supply (5V)	4.9
12	Not connected	0.0	40	Horizontal sync for OSD	0.7
13	Used for factory mode	4.9	41	Vertical sync for OSD	0.2
14	Not connected	0.0	42	Not connected	0.2
15	Blue output for OSD and TXT	0.7	43	Not connected	5.2
16	Green output for OSD and TXT	0.7	44	Not connected	0.0
17	Red output for OSD and TXT	0.7	45	LL' select output	4.8
18	Fast Blanking for OSD and TXT	0.0	46	Not connected	0.1
19	SDA I2C Bus Data Input	see osc.	47	Vertical linearity output	0.8
20	SCL I2C Bus Clock Input	see osc.	48	Standby/Mute	5.0 (0.2)
21	Supply Voltage (5V)	4.9	49	Standby/Mute	5.0 (0.2)
22	Not connected	0.9	50	Oscillator out	2.3
23	Ground	0.0	51	Oscillator in	2.4
24	Ground	0.0	52	Not connected	0.1
25	Analog Vdd of PLL	-	53	On/Off (standby activate/deactivate)	0.2 (2.8)
26	Testpins: must be tied to pin 25	-	54	Not connected	0.1
27	Analog pin for OSD	1.7	55	Not connected	0.0
28	Not connected	4.8	56	Status signal input of Scart pin 8	0.0

IC501 (TDA8174) Vertical Deflection Output IC

Pin	Connection	V DC	Pin	Connection	V DC
1	Power output	13.4	7	Ramp generator	5.5
2	Output stage Vs	27.6	8	Buffer output	6.4
3	Trigger input	4.0	9	Inverting input	4.5
4	Height adjustment	6.8	10	Vs	27.6
5	Not connected	4.5	11	Flyback generator	1.3
6	Ground	0.0			

IC701 (TDA6107) RGB Output IC

Pin	Connection	V DC	Pin	Connection	V DC
1	Red in	2.3-2.5	6	Vdd supply	190.0
2	Green in	2.5-2.7	7	Red out	134-137
3	Blue in	2.5-2.7	8	Green out	128-130
4	Gnd	0.0	9	Blue out	130-137
5	Black current output	4.5-5.5			

IC901 (TDA16847) Power Supply IC

Pin	Connection	V DC (*)	Pin	Connection	V DC (*)
1	Off time circuit (for standby frequency)	2.4 (0.4)	8	Power measurement output	1.5 (2.4)
2	Primary Current Simulation and Startup	1.9 (10.9)	9	Reference Ref. Voltage (5V)	4.9 (1.1)
3	Regulation and Zero Crossing Input	2.6 (0.3)	10	Fault Comparator 1 (not used)	0.0
4	Soft-Start and Regulation Capacitor	3.7 (0.3)	11	Primary Voltage Check	1.7 (2.5)
5	Opto Coupler Input (not connected)	4.9 (0.8)	12	Ground	0.0
6	Fault Comparator 2 (not used)	0.0	13	Output	4.0 (0.4)
7	Synchronization Input (for fixed freq.)	4.9 (1.1)	14	Supply Voltage	13.6 (11.7)

(*) Standby measurement values are given in parenthesis

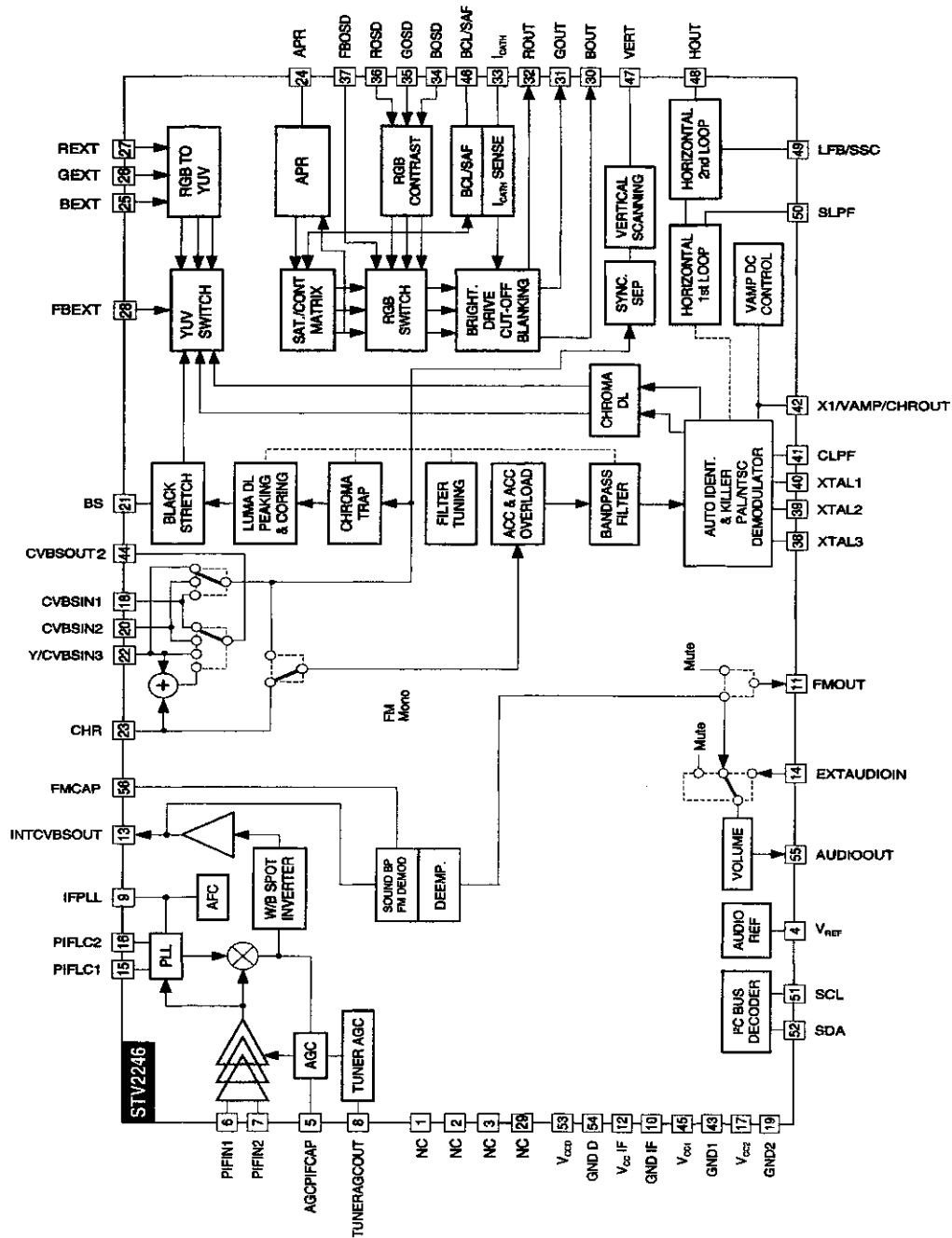

WAVEFORMS OF SOME IC PINS

Note:TV is connected to a pattern generator (Colour bar, sound 1 kHz).

IC101 (STV224X)

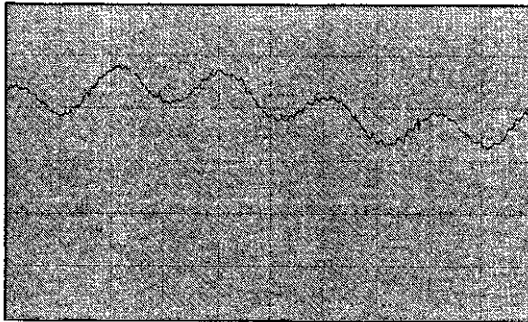

Pin 11

1V/div, 100 usn/div, Vpp=1.6 V

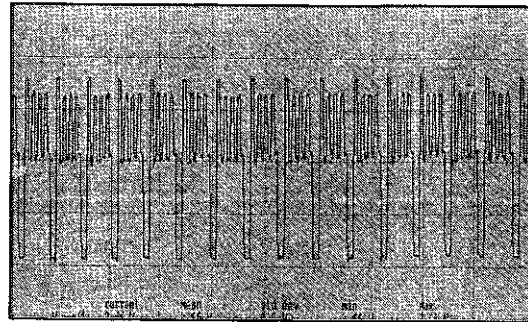

Pin 30

1V/div, 100 usn/div, Vpp=3.7 V, 15625 Hz

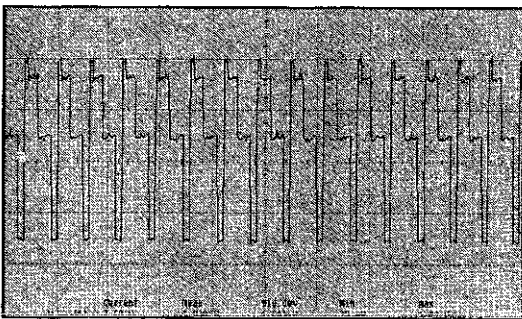

Pin 31

1V/div, 100 usn/div, Vpp=3.7 V, 15625 Hz

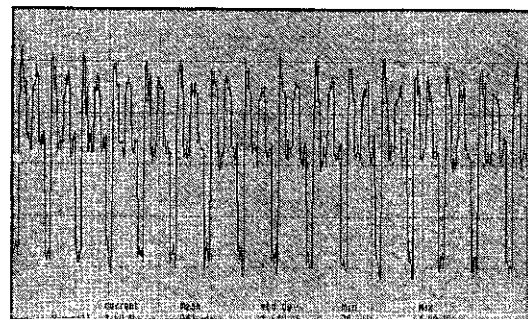

Pin 32

1V/div, 100 usn/div, Vpp=4.5 V, 15625 Hz

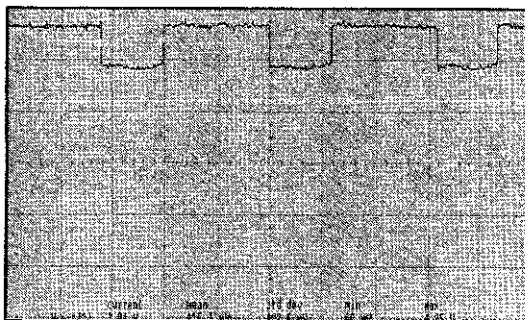

Pin 34 (OSD Off)

1V/div, 20 usn/div, Vpp=1 V, 15625 Hz

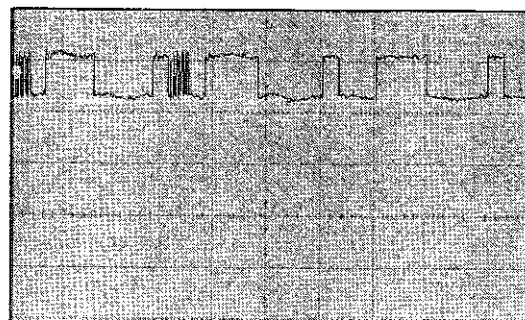

Pin 34 (OSD On)

1V/div, 20 usn/div, Vpp=1 V, 15625 Hz

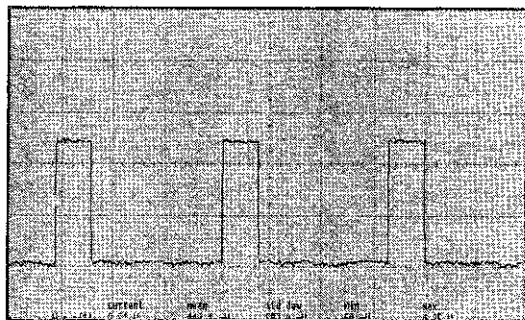

Pin 37 (OSD On)

1V/div, 20 usn/div, Vpp=2.51 V, 15625 Hz

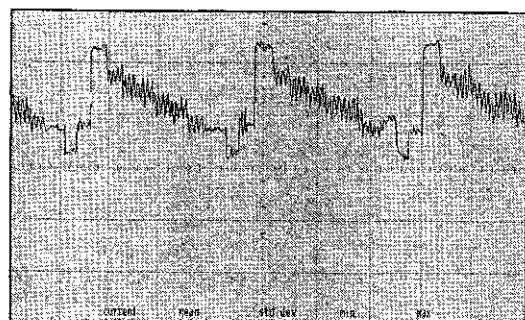

Pin 44

1V/div, 20 usn/div, Vpp=2.3 V, 15625 Hz

IC101 (STV224X)

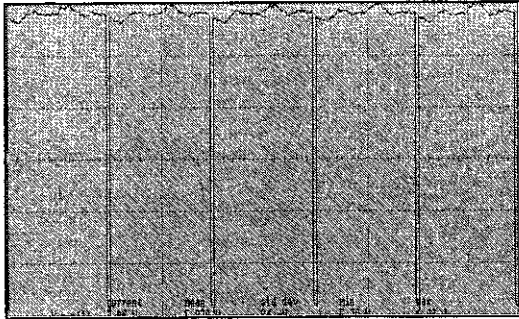

Pin 47

1V/div, 10 msn/div, $V_{pp}=6.0$ V, 50 Hz

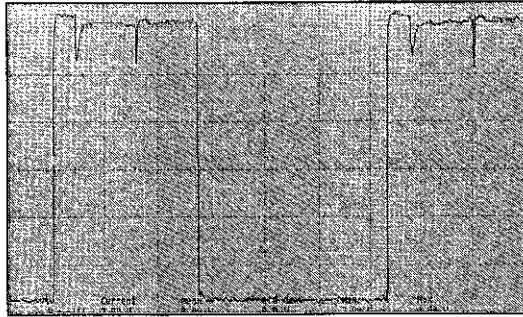

Pin 48

1V/div, 10 usn/div, $V_{pp}=3.1$ V, 15625 Hz

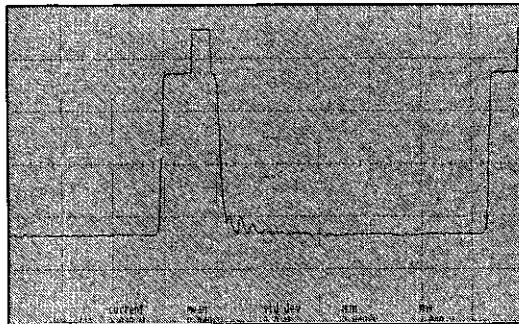

Pin 49

1V/div, 10 usn/div, $V_{pp}=3.9$ V, 15625 Hz

IC316 (MSP34X0G)

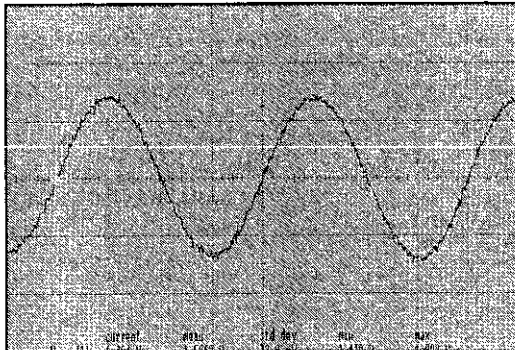

Pin 28

500mV/div, 50 usn/div, $V_{pp}=1.5$ V, 5kHz

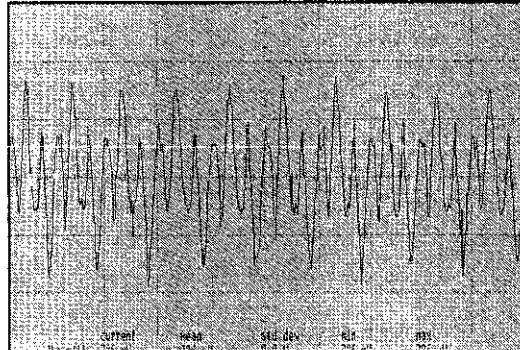

Pin 55

200mV/div, 20 msn/div, $V_{pp}=0.7$ V

IC317 (TDA7480)

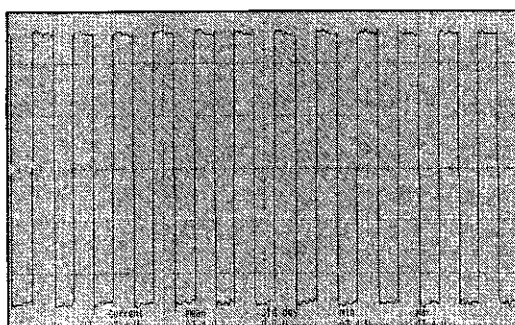

Pin 4

5 V/div, 10 usn/div, $V_{pp}=27.4$ V

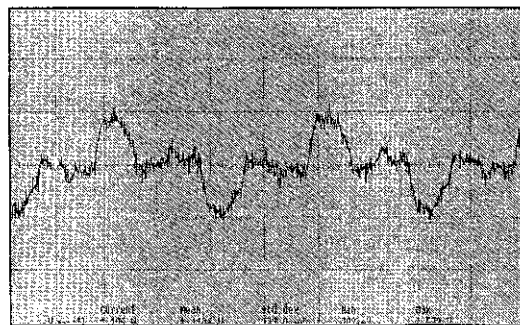

Pin 11

500mV/div, 5 usn/div, $V_{pp}=1.1$ V

IC402 (ST92195B)

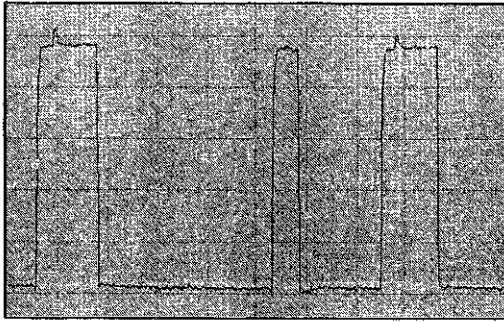

Pin 19

1V/div, 20 usn/div, Vpp=5.2 V

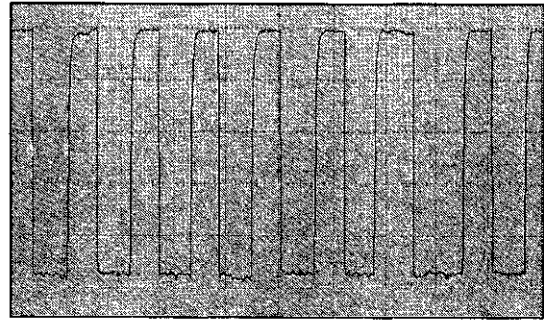

Pin 20

1V/div, 20 usn/div, Vpp=4.9 V, 15625 Hz

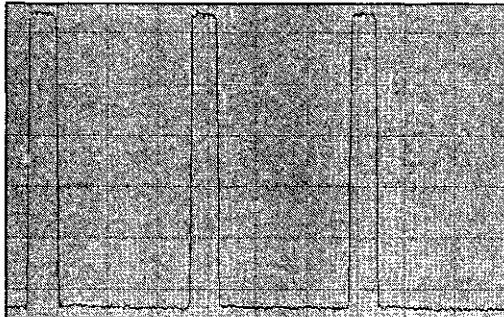

Pin 40

1V/div, 20 usn/div, Vpp=5.9 V, 15625 Hz

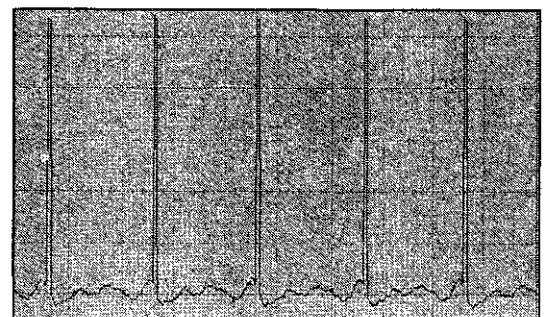

Pin 41

1V/div, 10 msn/div, Vpp=5.7 V, 50 Hz

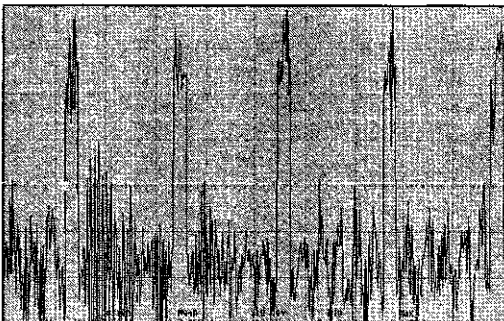

Pin 47

1V/div, 20 usn/div, Vpp=5.9 V, 15625 Hz

IC501 (TDA8174)

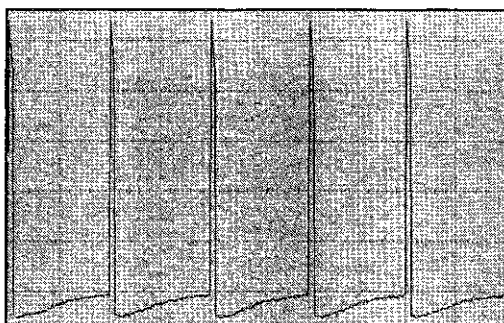

Pin 2

5V/div, 10 msn/div, Vpp=26.7 V, 50 Hz

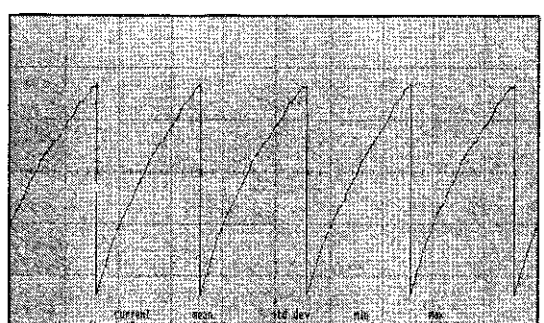

Pin 7

2V/div, 10 msn/div, Vpp=8.1 V, 50 Hz

IC701 TDA6107

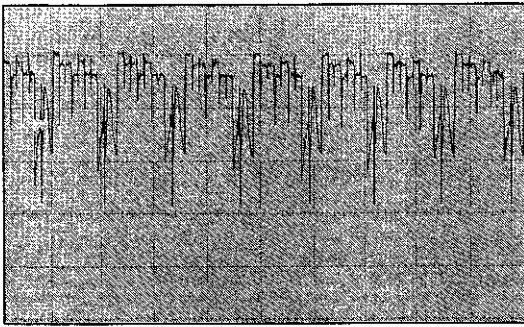

Pin 5

2V/div, 50 usn/div, Vpp=5.8 V, 15625 Hz

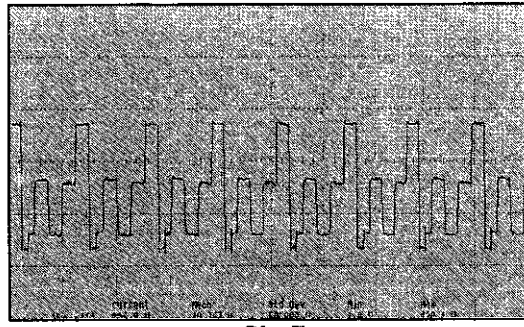

Pin 7

50V/div, 50 usn/div, Vpp=126.8 V, 15625 Hz

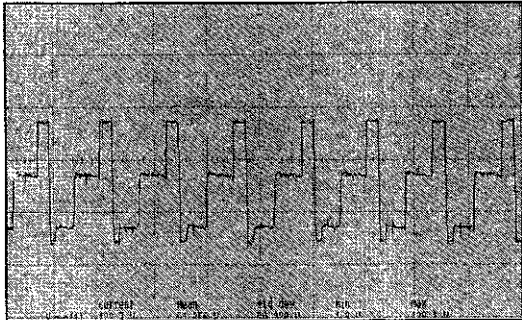

Pin 8

50V/div, 50 usn/div, Vpp=122.7 V, 15625 Hz

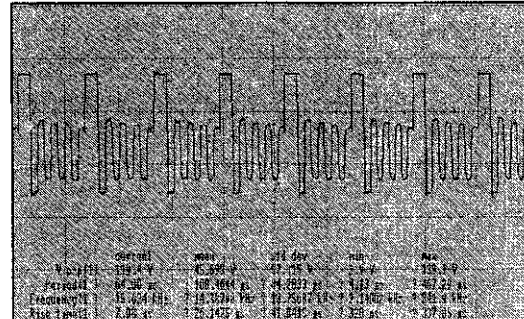

Pin 9

50V/div, 50 usn/div, Vpp=119.4 V, 15625 Hz

T551

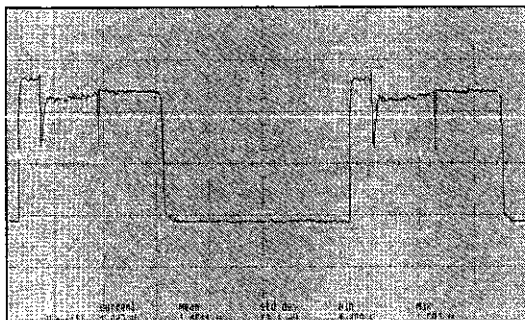

Base

500mV/div, 10 usn/div, Vpp=1.5V, 15625 Hz

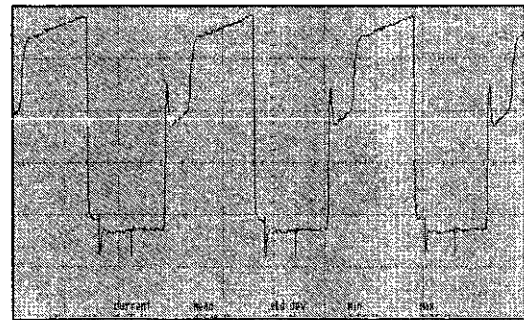

Collector

1 V/div, 20 usn/div, Vpp=4.7V, 15625 Hz

T552

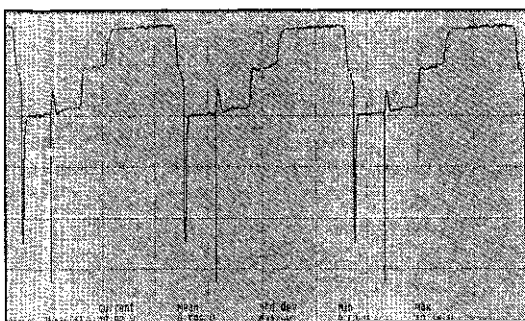

Base

2 V/div, 20 usn/div, Vpp=10V, 15625 Hz

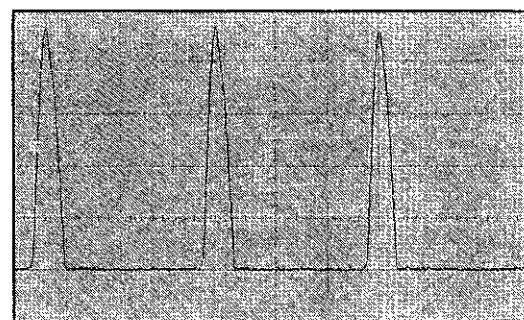

Collector

200 V/div, 20 usn/div, Vpp=932V, 15625 Hz

1. ELECTRICAL ADJUSTMENTS

1.1 Supply Voltage Adjustment

Connect a digital voltmeter to the cathode of diode D950 at the AV mode of the TV and set the screen voltage to the minimum with the screen potentiometer. Adjust the main supply voltage (B+) with P901 potentiometer to the following value (after supply adjustment, readjust Screen and focus voltage).

20" : 119 VDC (for A48ECR43X51)

21" : 114 VDC (for A51EER33X41)

2. SERVICE ADJUSTMENTS

You need the special service remote control to enter and exit the service menu of the TV (you can order it from the manufacturer). All buttons of the Service RC are same with the user remote control, only service menu In / Out is added to it (please see the picture below).

Navigation

Service In/Out : Enters to / exits from the Service Menu

P+ / P- : Moves upward / downward inside the menu

V+ / V- : Changes the values or options

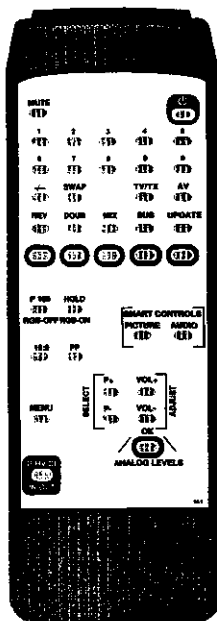

2.1 IF Adjustments

2.1.1 PAL SECAM BG/DK/I

- Apply a 38.9 MHz PAL colour bar RF signal to the pin 1 of SAW01 with a pattern generator. Switch on the Service Menu with the Service RC.
- Check that value of "VCO C" is "07". Adjust the coil LC100 until the colour of ":" sign turns red.
- Check that value of "VCO F" is "63". Adjust the coil LC100 until the colour of ":" sign turns red.
- Exit from the service menu with the Service RC.

2.1.2 SECAM L/L' (if available)

- Apply a 33.9 MHz SECAM L colour bar signal to the pin 1 of SAW01 with a pattern generator.
- Select the system as LL' in the TV setup menu. Switch on the Service Menu with the Service RC.
- Change the value of "VCO C L", until the colour of ":" sign turns red.
- Change the value of "VCO F L", until the colour of ":" sign turns red.
- Exit from the service menu with the Service RC.

2.2 AGC Adjustment

- Apply a signal with amplitude 65 ± 1 dBuV to the antenna input of TV with a pattern generator (switch sound carrier to Off and switch "Video Ext" to On).
- Switch on the Service Menu with the Service RC and find the "AGC1" with P+ / P- buttons.
- Measure the amplitude of 38.9 MHz sinusoidal signal on pin 11 (IF2) of Tuner with an oscilloscope.
- Adjust "AGC1" to get 540 ± 20 mVpp.
- Add 5 to "AGC1" value and change "AGC2" to this value.
- Exit from the service menu with the Service RC.

2.3 Screen Adjustment

- Switch on the Service Menu with the Service RC.
- Find item "SCRN" in the menu.
- Adjust the Screen potentiometre until the colour of ":" sign turns red.
- Exit from the service menu with the Service RC

2.4 White Balance Adjustment

- Apply a white pattern with a pattern generator to the antenna input.
- Enter the Service Menu with the Service RC and select "GRN" option with P+ / P- buttons and change its value to "0" with V+ / V- button.
- Adjust "RED" and "BLUE" for white balance. If white balance can not be adjusted properly change "GRN" value.
- Adjust "RED BIAS" and "GRN BIAS" for red and green cut off (There is no blue cut off adjustment).
- Exit from Service menu.

2.5 Geometry Adjustments

- Apply the cross hatch pattern with a pattern generator to the antenna input.
- Enter Service Menu with Service RC.
- Adjust Vertical Amplitude with "VAMP1 4/3 50Hz" option.
- Add 20 to "VAMP1 4/3 50Hz" value and change "VAMP2 16/9 50Hz" to this value.
- Subtract 18 from "VAMP1 4/3 50Hz" value and change "VAMP3 4/3 60Hz" to this value.
- Add 2 to "VAMP1 4/3 50Hz" value and change "VAMP4 16/9 60Hz" to this value.
- Adjust vertical position with "VSHT", vertical linearity with "VLIN", horizontal position with "HSHT" and vertical position of Teletext with "TXT VPOS".
- Exit from the Service Menu.

Note that: There is no horizontal width adjustment in this chassis. It can be adjusted by changing power supply voltage in the interval of -1 and +1 V.

2.6 Feature Options

TUNER	: Panasonic1 (ENV57D44G3), Panasonic2 (ENV57D60G3), Phillips, Sharp, Temic
SSTD	: BG, I, BG+DK, BG + L
NICAM	: NICAM On (available), NICAM Off
VIR.DOLBY	: Yes (available), No
XTAL	: 1 (4,43), 2 (4,43-3,58) (NTSC Playback available)
APPL	: INTERCAR (Intercarrier), QSS
OSD CONTR	: On (OSD level control is On), Off
BLUE SCRN	: On (Blue background available), Off
APR	: On (Max. RGB level control is On), Off
COFF BLNK	: On (Auto cut off stabilization control is On), Off
AM SND	: MSP34XX, STV224X
HEAD	: Yes (Headphone available), No
FASTTEXT	: Yes (available), No
NUM.OF AV	: Please see Table 1
AV2	: Please see Table 1
STD-BY	: ON (Default, Automatic switch off is active), OFF (can be used during repair)

	NUM.OF AV	AV2
1 Scart	01	NO
1 Scart + Front AV	02	CINCH Front-AV
1 Scart + Front AV + SVHS	03	CINCH Front-AV
2 Scarts	02	SCART 2
2 Scarts (SVHS available on Scart 2)	03	SCART 2
2 Scarts + Front AV	04	SCART 2
2 Scarts + Front AV + SVHS	05	SCART 2

Table 1

2.7 Factory Settings for Service Mode

Values given in Table 2 are typical values and can vary according to the CRT type.

		20"	21"
AGC1	Automatic Gain Control 1	32	32
AGC2	Automatic Gain Control 2	AGC1 + 5	AGC1 + 5
STD BY	Standby	ON	ON
SCRN	Screen (used for screen adj.)	OFF	OFF
VCO C	VOC Coarse (BG/I/DK)	07	07
VCO F	VCO Fine (BG/I/DK)	07	07
VCO C L	VOC Coarse (LL')	07	07
VCO F L	VCO Fine (LL')	07	07
RED	Red level	14	10
GRN	Green level	00	00
BLUE	Blue level	11	07
RED BIAS	Black level offset red	18	30
GRN BIAS	Black level offset green	23	28
VAMP1 4/3 50HZ	Vertical amplitude 4/3 PAL/SEC	33	32
VAMP2 16/9 50HZ	Vertical amplitude 16/9 PAL/SEC	VAMP1 + 20	VAMP1 + 20
VAMP3 4/3 60HZ	Vertical amplitude 4/3 NTSC	VAMP1 - 18	VAMP1 - 18
VAMP4 16/9 60HZ	Vertical amplitude 16/9 NTSC	VAMP1 + 2	VAMP1 + 2
TXT VPOS	Teletext Vertical Position	15	15
VSHT	Vertical shift	08	11
VLIN	Vertical linearity	31	31
HSHT	Horizontal shift	35	33

Table 2

2.8 Exit from Service Menu

During exit from service menu, the software version and feature options (hexadecimal number) are shown on the screen. For example: 12.3SX 14.11.01 SB5641-A02 44BA26.

CONVERGENCE ADJUSTMENTS

Note: Before attempting any convergence adjustments, the receiver should be operated for at least fifteen minutes.

• Centre Convergence Adjustment

1. Receive crosshatch pattern with a colour bar signal generator.
2. Adjust the BRIGHTNESS and CONTRAST Controls for well defined pattern.
3. Adjust two tabs of the 4-Pole Magnets to change the angle between them (See figure) and superimpose red and blue vertical lines in the central area of the picture screen. (See figure).
4. Turn both tabs at the same time keeping the constant angle to superimpose red and blue horizontal lines at the centre of the screen. (See figure)
5. Adjust two tabs of 6-Pole Magnets to superimpose red/blue line and green one. Adjusting the angle affects the vertical lines and rotating both magnets affects the horizontal lines.
6. Repeat adjustments 3,4,5 to ensure best convergence, the adjustment must be undertaken with great care because of the interaction between 4 and 6 pole magnets.

• Circumference Convergence Adjustment

1. Loosen the clamping screw of deflection yoke to allow the yoke to tilt.
2. Put a wedge as shown in figure temporarily. (Do not remove cover paper on adhesive part of the wedge.)
3. Tilt front of the deflection yoke up or down to obtain better convergence in circumference. (See figure) Push the mounted wedge into the space between picture tube and the yoke to fix the yoke temporarily.
4. Put other wedge into bottom space and remove the cover paper to stick.
5. Tilt front of the yoke right or left to obtain better convergence in circumference. (See figure)
6. Keep the yoke position and put another wedge in either upper space. Remove cover paper and stick the wedge on picture tube to fix the yoke.
7. Detach the temporarily mounted wedge and put it in another upper space. Stick it on picture tube to fix the yoke.
8. After fixing three wedges, re the yoke is firm.
9. Stick 3 adhesive tapes on wedges.

CONVERGENCE COMPENSATOR

Compensators L462A and L462B are used to correct misconvergence (Red-Green) at the top centre or bottom centre on screen, when the misconvergence is still evident even though the yoke adjustment is tried. Compensator L462C is also used to correct misconvergence (Vertical shift of Red or Blue) at four corners on screen.

1. To correct horizontal misconvergence (Red-Green), put compensator L462A on the yoke back (see figure) to find a position for minimizing misconvergence. Mark the position and remove protective paper on the rear of L462A to stick it in place. Apply adhesives on both yoke and L462A.
2. To correct vertical misconvergence (Red-Green), put the tips of compensator L462B into either of the holes on the yoke core and apply adhesives.
3. To correct up or down shift of Red at top right or bottom right corner, put compensator L462C at point 1 ve 2 or the picture tube (see figure.) to find a position for minimizing misconvergence. Mark the position and remove protective paper on the rear of L462C to stick it in place.

L462A (Put on the upper back or lower back.)

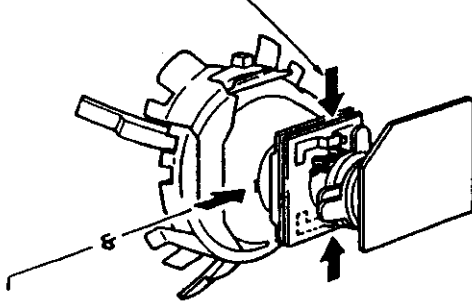

L462B (Put into the left hole or right hole.)

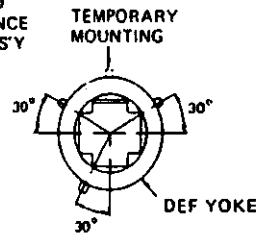
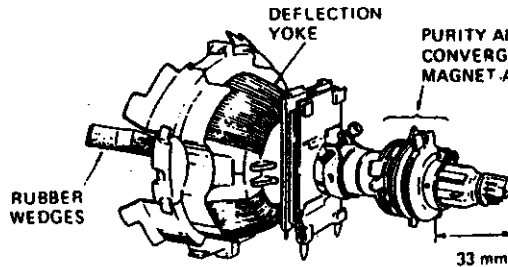
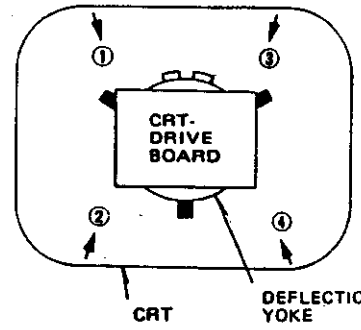

RUBBER WEDGES LOCATION

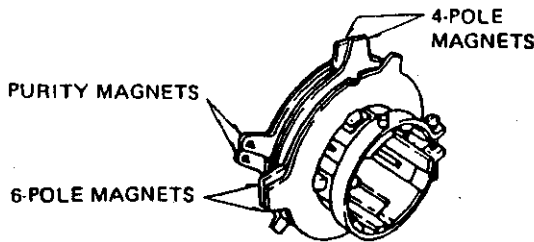

ADJUST THE ANGLE (VERTICAL LINES)

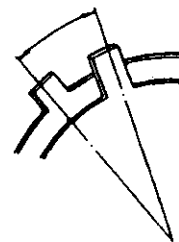

FIXED

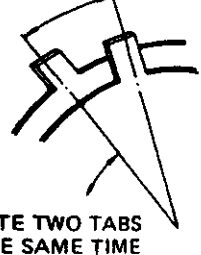

ROTATE TWO TABS AT THE SAME TIME (HORIZONTAL LINES)

CONVERGENCE MAGNET ASSEMBLY

ADJUSTMENT OF MAGNETS

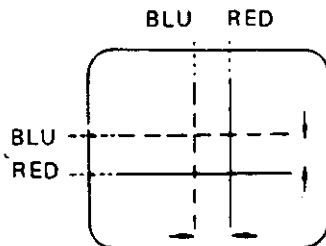

4-POLE MAGNETS MOVEMENT

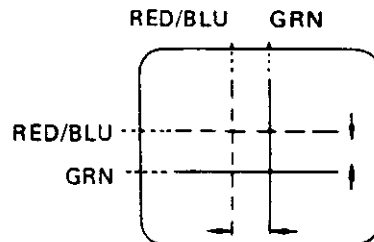

6-POLE MAGNETS MOVEMENT

Centre Convergence by Convergence Magnets

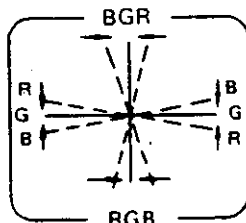

INCLINE THE YOKE UP (OR DOWN)

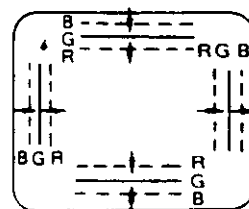

INCLINE THE YOKE RIGHT (OR LEFT)

Circumference Convergence by DEF Yoke

Dot Movement Pattern

CHANNEL TABLE FOR STANDARD B/G (CCIR)

Channel number (display)	Channel design.	Centre frequency (MHz)	Oscillator frequency (MHz)	Division ratio PLL (decimal)	Channel number (display)	Channel design.	Centre frequency (MHz)	Oscillator frequency (MHz)	Division ratio PLL (decimal)
C01	AU 0	46.25	85.125	1.362	C61	K61	791.25	830.125	13.282
C02	K2	483.25	87.125	1.394	C62	K62	799.25	838.125	13.410
C03	K3	55.25	94.125	1.506	C63	K63	807.25	846.125	13.538
C04	K4	62.25	101.125	1.618	C64	K64	815.25	854.125	13.666
C05	K5	1753.25	214.125	3.426	C65	K65	823.25	862.125	13.794
C06	K6	182.25	221.125	3.538	C66	K66	831.25	870.125	13.922
C07	K7	189.25	228.125	3.650	C67	K67	839.25	878.125	14.050
C08	K8	196.25	235.125	3.762	C68	K68	847.25	886.125	14.178
C09	K9	203.25	252.125	3.874	C69	K69	855.25	894.125	14.306
C10	K10	210.25	249.125	3.986	C70	EX	863.25	902.125	14.434
C11	K11	217.25	256.125	4.098	C71	EX	871.25	910.125	14.562
C12	K12	224.25	263.125	4.210	C72	EX	879.25	918.125	14.690
C13	A	23.75	92.625	1.482	C73	EX	887.25	926.125	14.818
C14	B	62.25	101.125	1.618	C74	EX	69.25	108.125	1.730
C15	C	82.25	121.125	1.938	C75	EX	76.25	115.125	1.842
C16	D	175.25	214.125	3.426	C76	EX	83.25	122.125	1.954
C17	E	183.75	222.625	3.562	C77	EX	90.25	129.125	2.066
C18	F	192.25	231.125	3.698	C78	EX	97.25	136.125	2.178
C19	G	201.25	240.125	3.842	C79	201	59.25	98.125	1.570
C20	H	210.25	249.125	3.986	C80	501	93.25	132.125	2.114
C21	K21	475.25	510.125	8.162	S01	S1	105.25	144.125	2.306
C22	K22	479.25	518.125	8.290	S02	S2	112.25	151.125	2.418
C23	K23	487.25	526.125	8.418	S03	S3	119.25	158.125	2.530
C24	K24	495.25	534.125	8.546	S04	S4	126.25	165.125	2.642
C25	K25	503.25	542.125	8.674	S05	S5	133.25	172.125	2.754
C26	K26	511.25	550.125	8.802	S06	S6	140.25	179.125	2.866
C27	K27	519.25	558.125	8.930	S07	S7	147.25	186.125	2.978
C28	K28	527.25	566.125	9.058	S08	S8	154.25	193.125	3.090
C29	K29	535.25	574.125	9.186	S09	S9	161.25	200.125	3.202
C30	R30	543.25	582.125	9.314	S10	S10	168.25	207.125	3.314
C31	R31	551.25	590.125	9.442	S11	S11	231.25	270.125	4.322
C32	K32	559.25	598.125	9.570	S12	S12	238.25	277.125	4.434
C33	K33	567.25	606.125	9.698	S13	S13	245.25	284.125	4.546
C34	K34	575.25	614.125	9.826	S14	S14	252.25	291.125	4.658
C35	K35	583.25	622.125	9.954	S15	S15	259.25	298.125	4.770
C36	K36	591.25	630.125	10.082	S16	S16	266.25	305.125	4.882
C37	K37	599.25	638.125	10.210	S17	S17	273.25	312.125	4.994
C38	K38	607.25	646.125	10.338	S18	S18	280.25	319.125	5.106
C39	K39	615.25	654.125	10.466	S19	S19	287.25	326.125	5.218
C40	K40	623.25	662.125	10.594	S20	S20	294.25	333.125	5.330
C41	K41	631.25	670.125	10.722	S21	S21	303.25	342.125	5.474
C42	K42	639.25	678.125	10.850	S22	S22	311.25	350.125	5.602
C43	K43	647.25	686.125	10.978	S23	S23	319.25	358.125	5.730
C44	K44	655.25	694.125	11.106	S24	S24	327.25	366.125	5.858
C45	K45	663.25	702.125	11.234	S25	S25	335.25	374.125	5.986
C46	K46	671.25	710.125	11.362	S26	S26	343.25	382.125	6.050
C47	K47	679.25	718.125	11.490	S27	S27	351.25	390.125	6.242
C48	K48	687.25	726.125	11.618	S28	S28	359.25	398.125	6.370
C49	K49	695.25	734.125	11.746	S29	S29	367.25	406.125	6.498
C50	K50	703.25	742.125	11.874	S30	S30	375.25	414.125	6.626
C51	K51	711.25	750.125	12.002	S31	S31	383.25	422.125	6.754
C52	K52	719.25	758.125	12.130	S32	S32	391.25	430.125	6.882
C53	K53	727.25	766.125	12.258	S33	S33	399.25	438.125	7.010
C54	K54	735.25	774.125	12.386	S34	S34	407.25	446.125	7.138
C55	K55	743.25	782.125	12.514	S35	S35	415.25	454.125	7.266
C56	K56	751.25	790.125	12.642	S36	S36	423.25	462.125	7.394
C57	K57	759.25	798.125	12.770	S37	S37	431.25	470.125	7.522
C58	K58	767.25	806.125	12.898	S38	S38	439.25	478.125	7.650
C59	K59	775.25	814.125	13.026	S39	S39	447.25	486.125	7.778
C60	K60	783.25	822.125	13.154	S40	S40	455.25	494.125	7.906
					S41	S41	463.25	502.125	8.034

CHANNEL FOR STANDARD I+

Channel number (display)	Channel design.	Centre frequency (MHz)	Oscillator frequency (MHz)	Division ratio PLL (decimal)	Channel number (display)	Channel design.	Centre frequency (MHz)	Oscillator frequency (MHz)	Division ratio PLL (decimal)
C01	R1	49.75	88.625	1.362	C61	R61	791.25	830.125	13.282
C02	R2	59.25	98.125	1.570	C62	R62	799.25	838.125	13.410
C03	R3	77.25	116.125	1.858	C63	R63	807.25	846.125	13.538
C04	R4	85.25	124.125	1.986	C64	R64	815.25	854.125	13.666
C05	R5	93.25	132.125	2.114	C55	R65	823.25	862.125	13.794
C06	R6	175.25	214.125	3.426	C66	R66	831.25	870.125	13.922
C07	R7	183.25	222.625	3.554	C67	R67	839.25	878.125	14.050
C08	R8	191.25	230.125	3.682	C68	R68	847.25	886.125	14.178
C09	R9	199.25	238.125	3.810	C69	R69	855.25	894.125	14.306
C10	R10	207.25	246.125	3.938	C70	170	863.25	902.125	14.434
C11	R11	215.25	254.125	4.066	C71	171	871.25	910.125	14.562
C12	R12	223.25	262.125	4.194	C72	172	879.25	918.125	14.690
C21	R21	471.25	510.125	8.162	C73	173	887.25	926.125	14.818
C22	R22	469.25	518.125	8.290	S01	S1	103.25	142.125	2.274
C23	R23	487.25	526.125	8.418	S02	S2	111.25	150.125	2.402
C24	R24	495.25	534.125	8.546	S03	S3	119.25	158.125	2.530
C25	R25	503.25	542.125	8.674	S04	S4	127.25	166.125	2.658
C26	R26	511.25	550.125	8.802	S05	S5	135.25	174.125	2.786
C27	R27	519.25	558.125	8.930	S06	S6	143.25	182.125	2.914
C28	R28	527.25	566.125	9.058	S07	S7	151.25	190.125	3.042
C29	R29	535.25	574.125	9.186	S08	S8	159.25	198.125	3.170
C30	R30	543.25	582.125	9.314	S09	S9	167.25	206.125	3.298
C31	R31	551.25	590.125	9.442	S10	S10	231.25	270.125	4.322
C32	R32	559.25	793.125	9.570	S11	S11	239.25	278.125	4.450
C33	R33	567.25	606.125	9.698	S12	S12	247.25	286.125	4.578
C34	R34	575.25	614.125	9.826	S13	S13	255.25	294.125	4.706
C35	R35	583.25	622.125	9.954	S14	S14	263.25	302.125	4.834
C36	R36	591.25	630.125	10.082	S15	S15	271.25	310.125	4.962
C37	R37	599.25	638.125	10.210	S16	S16	279.25	318.125	5.090
C38	R38	607.25	646.125	10.338	S17	S17	287.25	325.125	5.218
C39	R39	615.25	654.125	10.466	S18	S18	295.25	334.125	5.346
C40	R40	623.25	662.125	10.594	S19	S19	303.25	342.125	5.474
C41	R41	631.25	670.125	10.722	S11	S11	311.25	350.125	5.602
C42	R42	639.25	678.125	10.850	S23	S23	319.25	358.125	5.730
C43	R43	647.25	686.125	10.978	S24	S24	327.25	366.125	5.858
C44	R44	655.25	694.125	11.106	S25	S25	335.25	374.125	5.986
C45	R45	663.25	702.125	11.234	S26	S26	343.25	382.125	6.050
C46	R46	671.25	710.125	11.362	S27	S27	351.25	390.125	6.242
C47	R47	679.25	718.125	11.490	S28	S28	359.25	398.125	6.370
C48	R48	687.25	726.125	11.618	S29	S29	367.25	406.125	6.498
C49	R49	695.25	734.125	11.746	S30	S30	375.25	414.125	6.626
C50	R50	703.25	742.125	11.874	S31	S31	383.25	422.125	6.754
C51	R51	711.25	750.125	12.002	S32	S32	391.25	430.125	6.882
C52	R52	719.25	758.125	12.130	S33	S33	399.25	438.125	7.010
C53	R53	727.25	766.125	12.258	S34	S34	407.25	446.125	7.138
C54	R54	735.25	774.125	12.386	S35	S35	415.25	454.125	7.266
C55	R55	743.25	782.125	12.514	S36	S36	423.25	462.125	7.394
C56	R56	751.25	790.125	12.642	S37	S37	431.25	470.125	7.522
C57	R57	759.25	798.125	12.770	S38	S38	439.25	478.125	7.650
C58	R58	767.25	806.125	12.898	S39	S39	447.25	486.125	7.778
C59	R59	775.25	814.125	13.026	S40	S40	455.25	494.125	7.906
C60	R60	783.25	822.125	13.154	S41	S41	463.25	502.125	8.034

CHANNEL FOR STANDARD D/K (OIRT)

Channel number (display)	Channel design.	Centre frequency (MHz)	Oscillator frequency (MHz)	Division ratio PLL (decimal)	Channel number (display)	Channel design.	Centre frequency (MHz)	Oscillator frequency (MHz)	Division ratio PLL (decimal)
C01	R1	49.75	88.625	1.418	C61	R61	791.25	830.125	13.262
C02	R2	59.25	98.125	1.570	C62	R62	799.25	838.125	13.410
C03	R3	77.25	116.125	1.858	C63	R63	807.25	846.125	13.538
C04	R4	85.25	124.125	1.986	C64	R64	815.25	854.125	13.666
C05	R5	93.25	132.125	2.114	C65	R65	823.25	862.125	13.794
C06	R6	175.25	214.125	3.426	C66	R66	831.25	870.125	13.922
C07	R7	183.25	222.625	3.554	C67	R67	839.25	878.125	14.050
C08	R8	191.25	230.125	3.682	C68	R68	847.25	886.125	14.178
C09	R9	199.25	238.125	3.810	C69	R69	855.25	894.125	14.306
C10	R10	207.25	246.125	3.938	S01	S1	103.25	142.125	2.274
C11	R11	215.25	254.125	4.066	S02	S2	111.25	150.125	2.402
C12	R12	223.25	262.125	4.194	S03	S3	119.25	158.125	2.530
C21	R21	471.25	510.125	8.162	S04	S4	127.25	166.125	2.658
C22	R22	479.25	518.125	8.290	S05	S5	135.25	174.125	2.786
C23	R23	487.25	526.125	8.418	S06	S6	143.25	182.125	2.914
C24	R24	495.25	534.125	8.546	S07	S7	151.25	190.125	3.042
C25	R25	503.25	542.125	8.674	S08	S8	159.25	198.125	3.170
C26	R26	511.25	550.125	8.802	S09	S9	167.25	206.125	3.298
C27	R27	519.25	558.125	8.930	S10	S10	231.25	270.125	4.322
C28	R28	527.25	566.125	9.058	S11	S11	239.25	278.125	4.450
C29	R29	535.25	574.125	9.186	S12	S12	247.25	286.125	4.578
C30	R30	543.25	582.125	9.314	S13	S13	255.25	294.125	4.706
C31	R31	551.25	590.125	9.442	S14	S14	263.25	302.125	4.834
C32	R32	559.25	598.125	9.570	S15	S15	271.25	310.125	4.962
C33	R33	567.25	606.125	9.698	S16	S16	279.25	318.125	5.090
C34	R34	575.25	614.125	9.826	S17	S17	287.25	325.125	5.218
C35	R35	583.25	622.125	9.954	S18	S18	295.25	334.125	5.346
C36	R36	591.25	630.125	10.082	S19	S19	303.25	342.125	5.474
C37	R37	599.25	638.125	10.210	S22	S22	311.25	350.125	5.602
C38	R38	607.25	646.125	10.338	S23	S23	319.25	358.125	5.730
C39	R39	615.25	654.125	10.466	S24	S24	327.25	366.125	5.858
C40	R40	623.25	662.125	10.594	S25	S25	335.25	374.125	5.986
C41	R41	631.25	670.125	10.722	S26	S26	343.25	382.125	6.050
C42	R42	639.25	678.125	10.850	S27	S27	351.25	390.125	6.242
C43	R43	647.25	686.125	10.978	S28	S28	359.25	398.125	6.370
C44	R44	655.25	694.125	11.106	S29	S29	367.25	406.125	6.498
C45	R45	663.25	702.125	11.234	S30	S30	375.25	414.125	6.626
C46	R46	671.25	710.125	11.362	S31	S31	383.25	422.125	6.754
C47	R47	679.25	718.125	11.490	S32	S32	391.25	430.125	6.882
C48	R48	687.25	726.125	11.618	S33	S33	399.25	438.125	7.010
C49	R49	695.25	734.125	11.746	S34	S34	407.25	446.125	7.138
C50	R50	703.25	742.125	11.874	S35	S35	415.25	454.125	7.266
C51	R51	711.25	750.125	12.002	S36	S36	423.25	462.125	7.394
C52	R52	719.25	758.125	12.130	S37	S37	431.25	470.125	7.522
C53	R53	727.25	766.125	12.258	S38	S38	439.25	478.125	7.650
C54	R54	735.25	774.125	12.386	S39	S39	447.25	486.125	7.778
C55	R55	743.25	782.125	12.514	S40	S40	455.25	494.125	7.906
C56	R56	751.25	790.125	12.642	S41	S41	463.25	502.125	8.034
C57	R57	759.25	798.125	12.770					
C58	R58	767.25	806.125	12.898					
C59	R59	775.25	814.125	13.026					
C60	R60	783.25	822.125	13.154					
C61	K61	791.25	830.125	13.282					
C62	K62	799.25	838.125	13.410					
C63	K63	807.25	846.125	13.538					
C64	K64	815.25	854.125	13.666					
C65	K65	823.25	862.125	13.794					

CHANNEL TABLE FOR STANDARD L

Channel number (display)	Channel design.	Centre frequency (MHz)	Oscillator frequency (MHz)	Division ratio PLL (decimal)	Channel number (display)	Channel design.	Centre frequency (MHz)	Oscillator frequency (MHz)	Division ratio PLL (decimal)
C02	L2	55.75	90.125	1.442	C61	K61	791.25	830.125	13.282
C03	L3	60.50	94.875	1.518	C62	K62	799.25	838.125	13.410
C04	L4	63.75	98.125	1.570	C63	K63	807.25	846.125	13.538
C05	L5	176.00	214.875	3.438	C64	K64	815.25	854.125	13.666
C06	L6	184.00	222.875	3.566	C65	K65	823.25	862.125	13.794
C07	L7	192.00	230.875	3.694	C66	K66	831.25	870.125	13.922
C08	L8	200.00	238.875	3.822	C67	K67	839.25	878.125	14.050
C09	L9	208.00	246.875	3.950	C68	K68	847.25	886.125	14.178
C10	L10	216.00	254.875	4.078	C69	K69	855.25	894.125	14.306
C11	LUX	189.25	228.125	3.650	C70	EX	863.25	902.125	14.434
C12	K6	182.25	221.125	3.538	S01	B	116.75	155.625	2.490
C13	K8	196.25	235.125	3.762	S02	C	128.75	167.625	2.682
C14	K10	210.25	249.125	3.986	S03	D	140.75	179.625	2.874
C21	K21	471.25	510.125	8.162	S04	E	152.75	191.625	3.066
C22	K22	479.25	518.125	8.290	S05	F	164.75	203.625	3.258
C23	K23	487.25	526.125	8.418	S06	G	176.75	215.625	3.450
C24	K24	495.25	534.125	8.546	S07	S	188.75	227.625	3.642
C25	K25	503.25	543.025	8.674	S08	I	200.75	239.625	3.834
C26	K26	511.25	550.125	8.802	S09	J	212.75	251.625	4.026
C27	K27	519.25	558.125	8.930	S10	K	224.75	263.625	4.218
C28	K28	527.25	566.125	9.058	S11	L	236.75	275.625	4.410
C29	K29	535.25	574.125	9.186	S12	M	248.75	287.625	4.602
C30	K30	543.25	583.025	9.314	S13	N	260.75	299.625	4.794
C31	K31	551.25	590.125	9.442	S14	O	272.75	311.625	4.986
C32	K32	559.25	598.125	9.570	S15	P	284.75	323.625	5.178
C33	K33	567.25	606.125	9.698	S16	Q	296.75	335.625	5.370
C34	K34	575.25	614.125	9.826	S21	S21	303.25	343.025	5.474
C35	K35	583.25	623.025	9.954	S22	S22	311.25	350.125	5.602
C36	K36	591.25	630.125	10.082	S23	S23	319.25	358.125	5.730
C37	K37	599.25	638.125	10.210	S24	S24	327.25	366.125	5.858
C38	K38	607.25	646.125	10.338	S25	S25	335.25	374.125	5.986
C39	K39	615.25	654.125	10.466	S26	S26	343.25	383.025	6.050
C40	K40	623.25	662.125	10.594	S27	S27	351.25	390.125	6.242
C41	K41	631.25	670.125	10.722	S28	S28	359.25	398.125	6.370
C42	K42	639.25	678.125	10.850	S29	S29	367.25	406.125	6.498
C43	K43	647.25	686.125	10.978	S30	S30	375.25	414.125	6.626
C44	K44	655.25	694.125	11.106	S31	S31	383.25	423.025	6.754
C45	K45	663.25	702.125	11.234	S32	S32	391.25	430.125	6.882
C46	K46	671.25	710.125	11.362	S33	S33	399.25	438.125	7.010
C47	K47	679.25	718.125	11.490	S34	S34	407.25	446.125	7.138
C48	K48	687.25	726.125	11.618	S35	S35	415.25	454.125	7.266
C49	K49	695.25	734.125	11.746	S36	S36	423.25	463.025	7.394
C50	K50	703.25	742.125	11.874	S37	S37	431.25	470.125	7.522
C51	K51	711.25	750.125	12.002	S38	S38	439.25	478.125	7.650
C52	K52	719.25	758.125	12.130	S39	S39	447.25	486.125	7.778
C53	K53	727.25	766.125	12.258	S40	S40	455.25	494.125	7.906
C54	K54	735.25	774.125	12.386	S41	S41	463.25	503.025	8.034
C55	K55	743.25	782.125	12.514					
C56	K56	751.25	790.125	12.642					
C57	K57	759.25	798.125	12.770					
C58	K58	767.25	806.125	12.898					
C59	K59	775.25	814.125	13.026					
C60	K60	783.25	822.125	13.154					

SPARE PARTS LIST

PART NO	DESCRIPTION	NOTES	POSITION NUMBERS
250111	EC 1UF 16V 11*5 R:5		C101 C125 C136 C138 C141
293108	CC-CHIP 10NF K 50V /0805 X7		C102 C104 C140
251107	EC 10UF M 16V 11*5 R:5		C105 C111 C134 C142
293230	CC-CHIP 22NF K 50V /0805 X7		C108 C179
294331	CC-CHIP 330NF K 16V /0805 X		C109
291822	CC-CHIP 820PF J 50V /0805 N		C112 C131
251478	EC 47UF 16V 11*5 R:5		C113 C145
294111	CC-CHIP 100NF K 25V /0805 X		C119 C120 C121 C122
252112	EC 100UF 16V 11*6 R:5		C127
292476	CC-CHIP 4.7NF K 50V /0805 X		C128 C129 C188
250227	EC 2.2UF 16V 11*5 R:5		C130 C173 C174
252229	EC 220UF 16V 11*8 R:5		C135
250111	C-ELA 1UF 16V 11*5 R:5	LL' SYSTEM	C143
251107	EC 10UF M 16V 11*5 R:5		C144 C170 C189
291225	CC-CHIP 220PF K 50V /0805 X		C148 C154 C156
291225	CC-CHIP 220PF K 50V /0805 X		C149 C162 C164
292110	CC-CHIP 1NF K 50V /0805 X7R		C150 C151 C152 C153 C169
291477	CC-CHIP 470PF J 50V /0805 N		C155 C157 C163 C165
292110	CC-CHIP 1NF K 50V /0805 X7R		C158 C159 C160 C161
293230	CC-CHIP 22NF K 50V /0805 X7		C166 C171 C172
294111	CC-CHIP 100NF K 25V /0805 X		C167 C168
291103	CC-CHIP 100PF J 50V /0805 N		C175 C176 C177
291560	CC-CHIP 560PF J 50V /0805 N		C178
290274	CC-CHIP 27PF J 50V NPO 0805		C180
290684	CC-CHIP 68PF J 50V /0805 NPO	LL' SYSTEM	C184
294228	CC-CHIP 220NF Z 50V /0805 Y5U	LL' SYSTEM	C185 C186
202105	C-CE 1NF K 1KV Y5P R:5	LL' SYSTEM	C187
293108	CC-CHIP 10NF K 50V /0805 X7		C191 C192 C194 C195
290684	CC-CHIP 68PF J 50V /0805 NP		C200
252112	EC 100UF 16V 11*6 R:5		C315 C338 C339
293474	CC-CHIP 47NF K 50V /0805 X7		C316
274332	C-PEM 330NF K 63V R:5		C340 C341
292223	CC-CHIP 2.2NF K 50V /0805 X		C342 C343
291223	CC-CHIP 220PF J 50V /0805 N		C346
294109	CC-CHIP 100NF K 50V /0805 X		C347 C348 C349 C350 C351
299152	CC-CHIP 1.5PF C 25V/0805		C352 C353
293108	CC-CHIP 10NF K 50V /0805 X7		C354 C355 C356
250470	EC 4.7UF 16V 11*5 R:5		C358 C359 C360 C361
294331	CC-CHIP 330NF K 16V /0805 X	CINCH	C362 C363
251478	EC 47UF 16V 11*5 R:5		C370 C371
250227	EC 2.2UF 16V 11*5 R:5		C373 C374
274104	C-PEM 100NF K 63V R:5		C375 C377 C378 C380 C381
291271	CC-CHIP 270PF J 50V /0805 N		C383 C384
292476	CC-CHIP 4.7NF K 50V /0805 X		C388
291560	CC-CHIP 560PF J 50V /0805 N		C390
274471	C-PEM 470NF K 63V R:5		C392 C393
291103	CC-CHIP 100PF J 50V /0805 N		C395
293474	CC-CHIP 47NF K 50V /0805 X7		C401 C402 C404 C407 C420
203106	CC 10NF K 50V R:5		C405
292476	CC-CHIP 4.7NF K 50V /0805 X		C408 C409
250227	EC 2.2UF 16V 11*5 R:5		C410
290156	CC-CHIP 15PF K 50V /0805 NP		C412 C413
290821	CC-CHIP 82PF J 50V /0805 N7		C414
292223	CC-CHIP 2.2NF K 50V /0805 X		C415
251107	EC 10UF M 16V 11*5 R:5		C416 C418 C436
290222	CC-CHIP 22PF J 50V /0805 NP		C419 C424 C431 C432
294476	CC-CHIP 470NF K 16V /0805 X		C421
179001	RC-CHIP 0R /0805 2*1.25	BG/DK SYSTEM	C423 L108 R336 R337 R338
291560	CC-CHIP 560PF J 50V /0805 N		C429 C437 C438
252229	EC 220UF 16V 11*8 R:5		C430

SPARE PARTS LIST

PART NO	DESCRIPTION	NOTES	POSITION NUMBERS
251478	EC 47UF 16V 11*5 R:5		C433 C439
293108	CC-CHIP 10NF K 50V /0805 X7		C435
274227	C-PEM 220NF J 50V R:5		C501
253101	EC 1000UF 35V 25*13 R:5		C503
252476	EC 470UF 25V 11*10 R:5	21"	C504
250111	EC 1UF 16V 11*5 R:5		C505 C511 C512
293152	CC-CHIP 15NF K 50V /0805 X7		C508
273333	C-PEM 33NF K 100V R:5		C508A
291477	CC-CHIP 470PF J 50V /0805 N		C509
252105	EC 100UF 50V 12*8 R:5		C510
250100	EC 1UF 160V 11*6.3 R:5		C553
271390	C-PPM 390NF J 250V R:15		C554
272820	C-PPM 8.2NF %3.5 1.5/1.6KV	21"	C555
272912	C-PPM 9.1NF %3.5 1.5/1.6KV	20"	C555
274330	C-PEM 330NF J 250V R:15		C556
251109	EC 10UF 250V 16*10 R:5		C560
202105	CC 1NF K 1KV Y5P R:5		C561
274107	C-PEM 100NF J 100V R:5		C563
252229	EC 220UF 16V 11*8 R:5	21"	C564
252482	EC 470UF 16V 12.5*10 R:5	20"	C564
271331	C-PPM 330PF J 1500V/1600V R		C565
251478	EC 47UF 16V 11*5 R:5		C571
251109	EC 10UF 250V 16*10 R:5		C702 C703
273225	C-PEM 22NF J 63V R:5		C704
202221	C-CE 2.2NF K 2KV Y5P R:7.5		C705
274224	C-PEM 220NF K 275V-AC R22	⚠	C901
274103	C-PEM 100NF K 275V-AC R:15	⚠	C902
202105	CC 1NF K 1KV Y5P R:5		C903 C904 C917 C918
203330	C-PPM 33NF J 630V R:15		C906
201471	CC 470PF 2KV		C907
293108	CC-CHIP 10NF K 50V /0805 X7		C909
293474	CC-CHIP 47NF K 50V /0805 X7		C910 C955 C958 C967
291123	CC-CHIP 120PF K 50V /0805 X		C911
292223	CC-CHIP 2.2NF K 50V /0805 X		C913 C914
274105	C-PEM 100NF J 250V R:10	⚠	C915 C701
274332	C-PEM 330NF K 63V R:5		C919
202220	CC 2.2NF M 250VAC Y5U R:10	⚠	C920
202106	CC 1NF K 50V Y5P R:5	CINCH	C920 C921
202102	C-CEA 1NF K 50V R:10	CINCH	C922 C923
290561	CC-CHIP 56PF J 50V NPO 0805	CINCH	C923
273471	C-PEM 47NF K 63V R:5	HEADPHONE	C940 C941
201226	CC 220PF K 2KV Y5P R:5		C950
250470	EC 4.7UF 16V 11*5 R:5		C956
251225	EC 22UF 16V 11*5 R:5		C965
291101	CC-CHIP 100PF J 50V /1206 N		C981 C982
302296	DIODE 1N4148 26MM		D103
302289	DIODE 1N4148 52MM		D103
303195	DIODE 4148 MELF		D107
303223	DIODE-CHIP BA682 SOD80	LL' SYSTEM	D180 D181
303988	LED LTL 4224 RED (SHORT LEG	21"	D418
303850	LED LTL 4263 RED L=25.4	20"	D418
303308	DIODE RF2007		D502
302296	DIODE 1N4148 26MM		D503 D559
300305	DIODE BA157		D552 D556
303217	DIODE RGP10J		D553 D560
303195	DIODE 4148 MELF		D557
302289	DIODE 1N4148 52MM		D558
302948	DIODE 1N4007		D701
303209	DIODE BAV21		D702 D703 D704

SPARE PARTS LIST

PART NO	DESCRIPTION	NOTES	POSITION NUMBERS
303206-01	DIODE RGP30M		D901 D902 D903 D904
303217	DIODE RGP10J		D905 D950
302289	DIODE 1N4148 52MM		D906 D907 D908 D909
303813	DIODE RGP15D		D951 D952
303993	LED LTL4221N D:3 R/D RED		D980
303991	LED IR SIR563SB3F 23/940		D981
056721	SER.FILTER TPS5.5MWA	BG SYSTEM	F101
056762	SER.FILTER TPT02B	BG/DK SYSTEM	F101
056745	SER.FILTRE TPS6.0MB	I SYSTEM	F101
056731	SER.FILTRE TPSRD5M50W00-A0	LL' SYSTEM	F101
056640-01	SER.FILTRE MKT40.4MA110P-TF01 MURATA	LL' SYSTEM	F102
056640-01	SER.FILTER MKT40.4MA110P-TF		F401
056641	SER.FILTRE MKT40.9MA110P MURATA	I SYSTEM	F401
452842	IC STV2246-5X	PAL BG, I SYSTEMS	IC101
452836-01	IC STV2248C	PAL + SECAM LL' SYSTEM	IC101
452990	IC STV2249C	PAL/SEC BG/DK SYSTEM	IC101
452985	IC-CHIP MC14053BD SOIC16	TWO SCARTS	IC102
452374	IC L78L05 ACZ TR		IC315 IC953
452575-01	IC MSP3400G	NON NICAM	IC316
452800	IC MSP3410G PSDIP64 AUDIO P	NICAM	IC316
452989	IC TDA7480L		IC317 IC318
452844	IC-CHIP ST24C08 (EEPROM) 5V		IC401
458641	IC ST92T195B7 (64K TX) OTP		IC402
452648	IC TDA8174AW		IC501
452746	IC TDA6107Q		IC701
452986	IC TDA16847		IC901
50S310	INSULATER BUZ90 17*12*.15		IC901
451518	IC KA317TU T0220CASE		IC951
452382	IC-CHIP S3C1840DA9/SMB1		IC980
053711	COIL 10UH K (TAIYO) LAL03		L101 L102 L315 L316
053805	COIL-CHIP TUH K /0805		L103 L106
053740	COIL TUH K LAL03		L104
053750	COIL 5.6UH K	DK SYSTEM	L105
053806	COIL-CHIP 8.2UH K /0805	BG SYSTEM	L107
179001	RC-CHIP OR /0805 2*1.25	LL' SYSTEM	L107
053781	COIL 2.2UH LAL04		L317 L318 L319 L320 L321
053353	COIL- CHOKE 68UH /1A RADIAL		L323 L324
053749	COIL 18UH K /3.4 26MM		L401 L402
053798	COIL-CHIP 18UH K /0805		L403 L404
053715	COIL 6.8UH K R12.5	⚠	L502
051585	COIL H-LIN 70UH		L551
053352	COIL- CHOKE 10UH R0814 14.1		L701
051815	LINE FILTER 2 X 18 MH MIN.TYPE	⚠	L901
053739	COIL CHOKE 50UH		L950
053506-01	COIL DEMOD 38.9 HEX		LC100
055597	FERRITE BEAD 12*8		
132500	R-VAR 5K (V) 5*3		P901
031780	CONN.HOUSING 2LI GREY		PL501
031777	CON.HOUSING LOCKED 5/4		PL551
056023	CRYSTAL 4.433619MHZ		Q101
056660	CRYSTAL 3.579545 90OHM		Q102
056952	CRYSTAL 18.432MHZ +-30PPM		Q315
056013	CRYSTAL 4 MHZ		Q401
056210	CER.RESONATOR GSB455E		Q980
173273	CFR-CHIP 27K J 1/10W /0805		R101 R427

SPARE PARTS LIST

PART NO	DESCRIPTION	NOTES	POSITION NUMBERS
171150	RC-CHIP 150R J 1/10W /0805		R102 R124 R333 R334
171221	RC-CHIP 220R J 1/10W /0805		R104 R129 R441 R442
172101	RC-CHIP 1K J 1/10W /0805		R105 R112 R117 R120 R144
170472	RC-CHIP 47R J 1/10W /0805		R107 R106 R108 R113
101470	CFR 470R J 1/4W /6 52MM		R109 R110 R111
171471	RC-CHIP 470R J 1/10W /0805		R116
171102	RC-CHIP 100R J 1/10W /0805		R118 R119 R160
102141	CFR 1K J 1/4W /6 26MM		R121
172823	RC-CHIP 8.2K J 1/10W /0805		R122
172561	RC-CHIP 5.6K J 1/10W /0805		R123 R415 R416
171182	RC-CHIP 180R J 1/10W /0805		R125 R126
172101	RC-CHIP 1K J 1/10W /0805		R127 R172 R173
173101	RC-CHIP 10K J 1/10W /0805		R128
173562	RC-CHIP 56K J 1/10W /0805		R130
174331	RC-CHIP 330K J 1/10W /0805		R131 R188
172225	RC-CHIP 2.2K J 1/10W /0805		R132
171270	RC-CHIP 270R J 1/10W /0805		R135 R136 R137
173479	RC-CHIP 47K J 1/10W /0805		R138
172335	RC-CHIP 3.3K J 1/10W /0805		R139
171221	RC-CHIP 220R J 1/10W /0805	LL' SYSTEM	R142
170750	RC-CHIP 75R J 1/10W /0805		R152 R154 R163 R164 R166
170683	RC-CHIP 68R J 1/10W /0805		R157
170750	RC-CHIP 75R J 1/10W /0805		R158 R174
171332	RC-CHIP 330R J 1/10W /0805		R159 R161 R168 R208
171102	RC-CHIP 100R J 1/10W /0805		R160 R162 R182 R183 R184 R189
172101	RC-CHIP 1K J 1/10W /0805		R165 R167
171102	RC-CHIP 100R J 1/10W /0805		R169 R171 R121
172475	RC-CHIP 4.7K J 1/10W /0805		R175 R176
173479	RC-CHIP 47K J 1/10W /0805		R177 R178 R179 R180
101117	RC 100R J 1/4W 26MM	LL' SYSTEM	R185
173101	RC-CHIP 10K J 1/10W /0805	LL' SYSTEM	R186 R191
102338	RC 3.3K J 1/4W /6 52MM	LL' SYSTEM	R190 R192
172225	RC-CHIP 2.2K J 1/10W /0805	LL' SYSTEM	R193
101106	RC 100R J 1/4W 52MM	LL' SYSTEM	R194
179002	RC-CHIP 0R /1206	LL' SYSTEM	R195
179001	RC-CHIP 0R /0805 2*1.25		R203 R209 L109 R181
171332	RC-CHIP 330R J 1/10W /0805	HEADPHONE	R315 R316
172335	RC-CHIP 3.3K J 1/10W /0805		R317 R318 R320
171102	RC-CHIP 100R J 1/10W /0805		R321 R322
171471	RC-CHIP 470R J 1/10W /0805	CINCH	R328 R345
173123	RC-CHIP 12K J 1/10W /0805		R329 R330
291103	CC-CHIP 100PF J 50V /0805 N		R335
173154	RC-CHIP 15K J 1/10W /0805		R343 R412
172475	RC-CHIP 4.7K J 1/10W /0805		R344 R432 R422
170047	RC-CHIP 4.7R J 1/10W /0805		R346
173101	RC-CHIP 10K J 1/10W /0805		R401 R404 R426 R428
172475	RC-CHIP 4.7K J 1/10W /0805		R402 R406 R407 R408 R434 R440
172225	RC-CHIP 2.2K J 1/10W /0805		R403
172273	RC-CHIP 2.7K J 1/10W /0805		R405 R511
172101	RC-CHIP 1K J 1/10W /0805		R409 R520
171471	RC-CHIP 470R J 1/10W /0805		R410 R411
171332	RC-CHIP 330R J 1/10W /0805		R417
171685	RC-CHIP 680R J 1/10W /0805		R425 R564
172823	RC-CHIP 8.2K J 1/10W /0805		R435 R438
173393	RC-CHIP 39K J 1/10W /0805		R437 R904
129236	RW 2.2R J 0.75W 73MM		R501
101471	CFR 470R J 1/2W /9 52MM		R502 R557
100220	CFR 22R J 1/2W 52MM		R503
174151	RC-CHIP 150K J 1/10W /0805		R505 R506
172183	RC-CHIP 1.8K J 1/10W /0805		R508 R512

SPARE PARTS LIST

PART NO	DESCRIPTION	NOTES	POSITION NUMBERS
119125	RM 1.2R J 1/2W 52MM	21"	R509
119153	RM 1.5R J 1/2W 52MM	20"	R509
170472	RC-CHIP 47R J 1/10W /0805	21"	R510
173101	RC-CHIP 10K J 1/10W /0805		R513 R423
102141	CFR 1K J 1/4W /6 26MM		R519
174104	RC-CHIP 100K J 1/10W /0805		R521
172823	RC-CHIP 8.2K J 1/10W /0805		R522
172225	RC-CHIP 2.2K J 1/10W /0805		R523
172394	RC-CHIP 3.9K J 1/10W /0805		R524
103224	CFR 22K J 1/4W 52MM		R526
110823	RMO 82R J 3W R:20		R554
100473	CFR 47R J 1/4W /6 52MM		R555 R921
113114	RM 10K J 1/2W 52MM		R558
119337	RMO 3.3R J 2W R:27.5 TAPE	▲	R559
119478	RMF 0.47R J 1W	▲ 20"	R560
119109	RNF 0.1R J 0.4W (UFLB) 52MM	▲ 21"	R560
103136	CFR 10K J 1/4W /6 26MM		R562
172683	RC-CHIP 6.8K J 1/10W /0805	21"	R563
172823	RC-CHIP 8.2K J 1/10W /0805	20"	R563
101681	CFR 680R J 1/2W /9 52MM		R568
103475	CFR 47K J 1/4W /6 52MM		R705
102159	CFR 1.5K J 1/2W /9 52MM		R711 R713 R715 R716
101683	CFR 680R J 1/4W /6 52MM		R901
154216	NTC 5.1R M (S234R)		R901
102166	CFR 1.5K J 1/4W /6 26MM		R902 R903
113683	RMO 68K J 1.5W 73MM		R903
173101	RC-CHIP 10K J 1/10W /0805		R905
114825	RM 820K %1 1/4W 52MM		R907 R908
172335	RC-CHIP 3.3K J 1/10W /0805		R909
114560	RM 560K %1 1/4W 52MM		R911 R922
174223	RC-CHIP 220K J 1/10W /0805		R912
115225	RMO 2.2M J 1/2W		R913
171822	CFR-CHIP 820R J 1/10W /0805		R914
173221	RC-CHIP 22K J 1/10W /0805		R915
172683	RC-CHIP 6.8K J 1/10W /0805		R917
173333	RC-CHIP 33K J 1/10W /0805		R918
115470	RM 4.7M J 1/2W 52MM	▲	R920
113393	RM 39K J .5W 52MM	▲	R950
171240	RC-CHIP 240R %1 1/10W /0805		R953
112131	RM 1.3K %1 1/4W 26MM		R954
109560	CFR 5.6R J 1/4W /3.2 52MM		R956
101106	CFR 100R J 1/4W 52MM		R957
129109	RWF 0.1R J 0.75W 73MM	▲	R959
119109	RNF 0.1R J 0.4W (UFLB) 52MM	▲	R960
179002	RC-CHIP 0R /1206		R981
452521	IR RECEIVER TSOP 1838	▲	S401
054261	FUSE 2.5AT (215 SER.)	▲	S901
056749	SAW FILTER OFW G1985M	BG SYSTEM	SAW1
056070	SAW FILTER OFW K2966M	BG/DK SYSTEM	SAW1
056114	SAW FILTRE OFW J1980M I SISTEM	I SYSTEM	SAW1
056709	SAW FILTRE OFW K3953M	LL' SYSTEM	SAW1
056767	SAW FILTRE OFW K9456M	LL' SYSTEM	SAW2
031251	SCART SOCKET 14.1		SK101
031197	SCART SOKET HR-DM2441S-O		SK102
7KY136-PS1	TUNER ENV57D60G3 ASIMETRIK		T100
401141	TRN-CHIP BC848B SOT23		T101 T102 T103
401141	TRN-CHIP BC848B SOT23	LL' SYSTEM	T105 T108
400989	TRN BC558B	HEADPHONE	T315 T316

SPARE PARTS LIST

PART NO	DESCRIPTION	NOTES	POSITION NUMBERS
401142	TRN-CHIP BC858B SOT23		T317 T318 T319 T320
401141	TRN-CHIP BC848B SOT23		T321 T322
401142	TRN-CHIP BC858B SOT23		T401
401141	TRN-CHIP BC848B SOT23		T406 T501 T502 T402
401334	TRN STX112		T551
401332	TRN BU808DFI		T552
401216-02	TRN 2SK2545		T901
400901	TRN BC327-25		T902
401141	TRN-CHIP BC848B SOT23		T906
401047	TRN BC337-25		T950
401142	TRN-CHIP BC858B SOT23		T980
058013-TR1	FBT 20/21" 12.1	⚠	TR552
059315	SMT 90" 12.3 STEREO	⚠	TR901
031882	CONN.HOUSING X2010 GREY	SINGLE SCART	X102
031751	CONN.HOUSING 2212 GREY	TWO SCARTS	X102
031730	CONN.HOUSING 2012 GREY		X103
031856	CONN.HOUSING X2003 BLACK		X104
031422	CONN.FEMALE 12P GREY		X315
031854	CONN.HOUSING X2003 GREY		X316
031323	CON.MKF19400-6-0-1010	SINGLE SCART	X317
031422	CONN.FEMALE 12P GREY	TWO SCARTS	X317
031857	CONN.HOUSING X2003 RED		X318
031860	CONN.HOUSING X2004 BLACK		X319
031858	CONN.HOUSING X2004 GREY		X320
031864	CONN.HOUSING X2005 BLACK		X401
031530-01	INCHANG/CRT SOCKET ISHM05S-		X703
031675	CON.HOUSING 2P MALE		X901 X902
031162	CONN. CINCH RCA PJ803-4 YEL		X921
031161	CONN. CINCH RCA PJ803-3 RED		X922
031160	CONN. CINCH RCA PJ803-2 WHI		X923
031180	CONN.HEADPHONE 12.1 FRONT-A		X941
302297	DIODE Z. 3.9V 26MM		ZD406
303771	DIODE Z. UZT33V		ZD570
303110	DIODE Z. 3.3V		ZD901
303735	MTZJ5.6B		ZD952
7HA110	B5 CHASSIS 20"	20" PAL BG NICAM HP CINCH	
M17110	B5 CHASSIS 21"	21" PAL BG ST	
M38110	B5 CHASSIS 21	21" PAL/SEC BG/DK NICAM	
056520-SB1	CPT SEB A48ECR43X51		
056521-SB1	CPT SEB A51EER33X41		
620167-AS	DEGAUSSING COIL ASSY 20" BA	⚠	
621167-AS	DEGAUSSING COIL ASSY 21" BA	⚠	
7TV187	RC A TYPE FUME 14.1		
6VM187	RC A TYPE SILVER 14.1		
7TK187	RC B TYPE FUME 14.1		
528107-AS	SPK.FOST.8R/7W PRJ-C POWER-		
7ZY107-AS	SPK.FT 8R/7W(NOM)(120X50MM)		

Please note that Product Part List Files should be investigated for the mechanical parts like cabinets, etc.

12.3 CTV CHASSIS

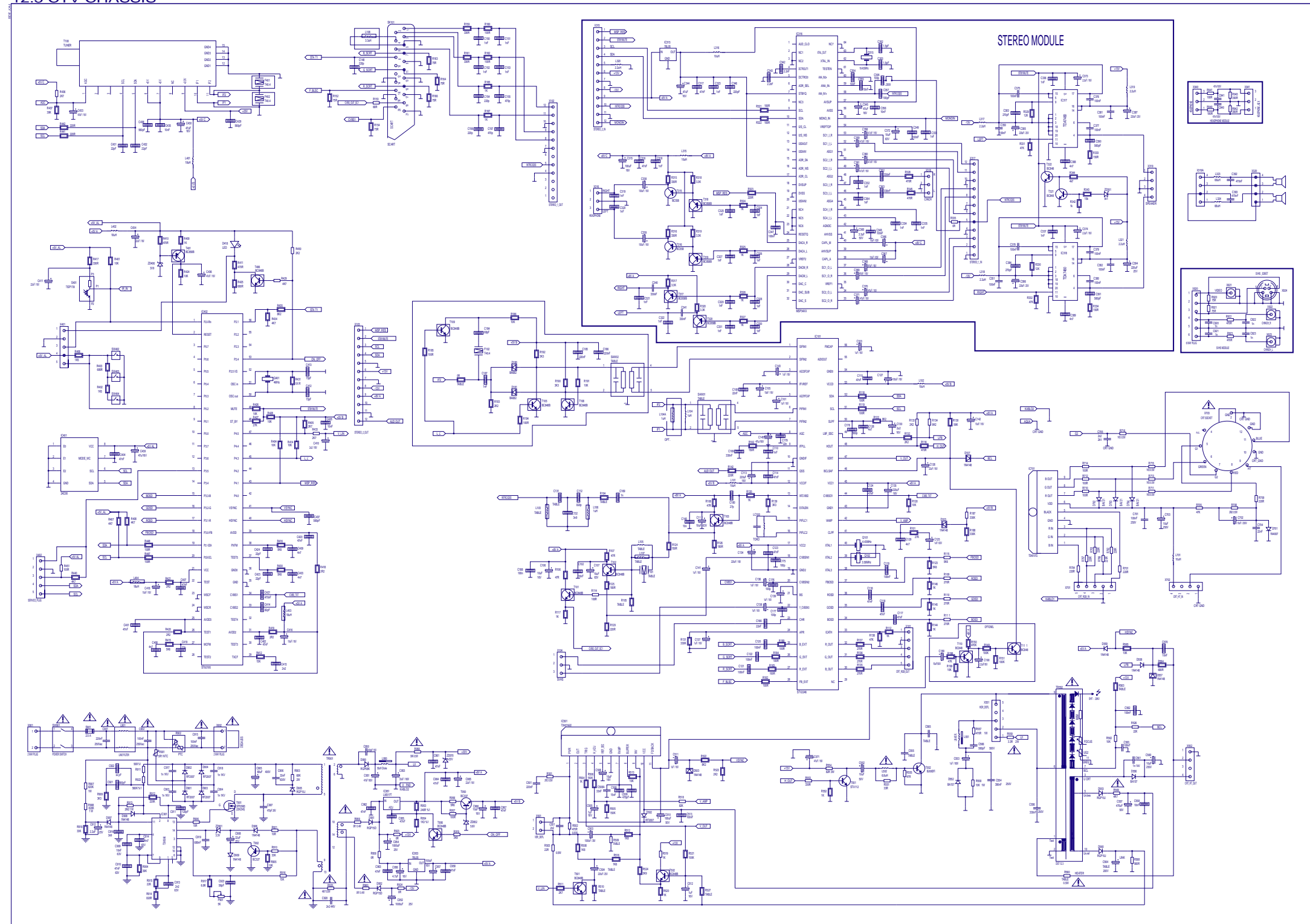

CHASSIS

