

TEVION

TV-5530VT

MODEL

SERVICE MANUAL

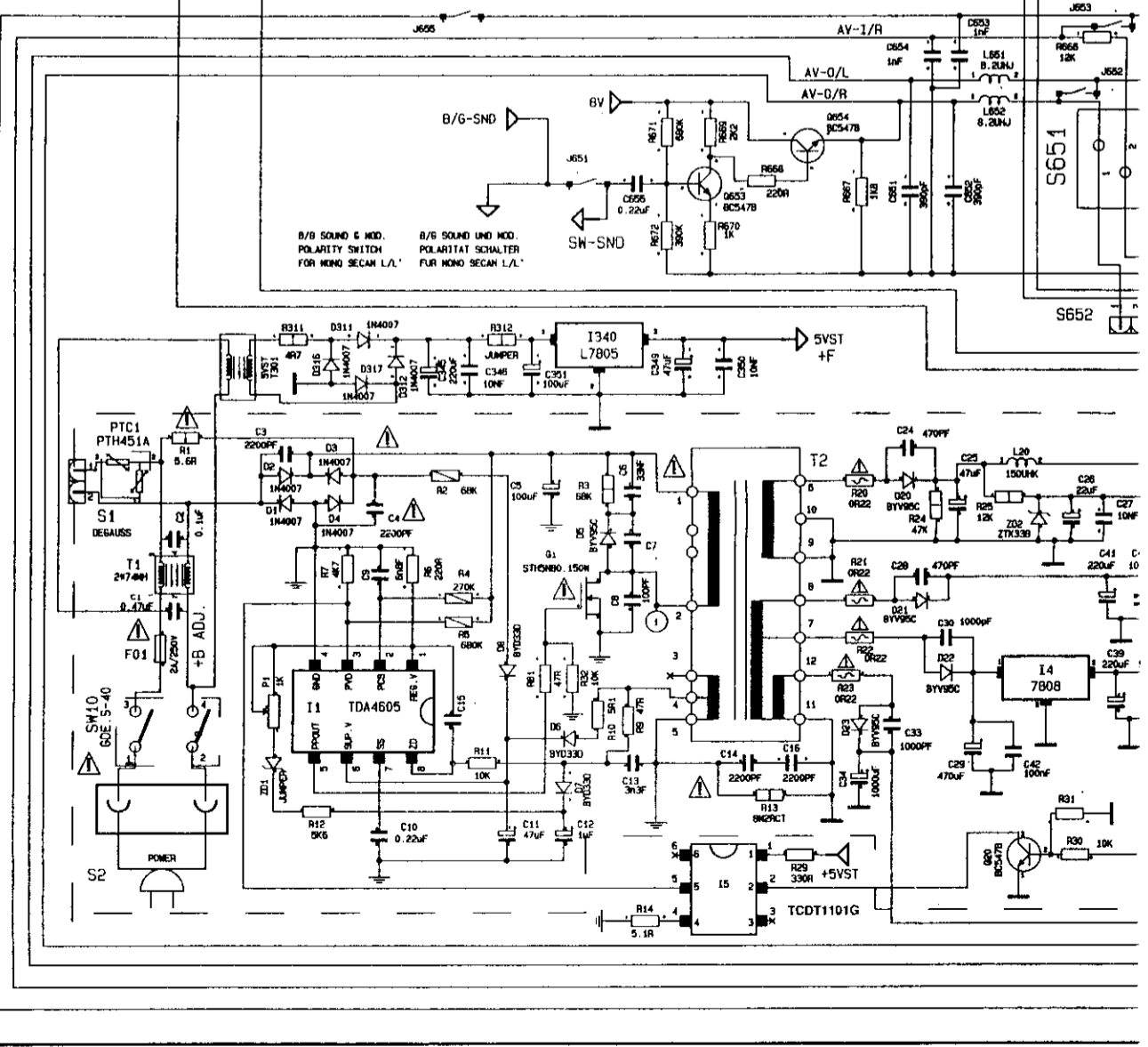
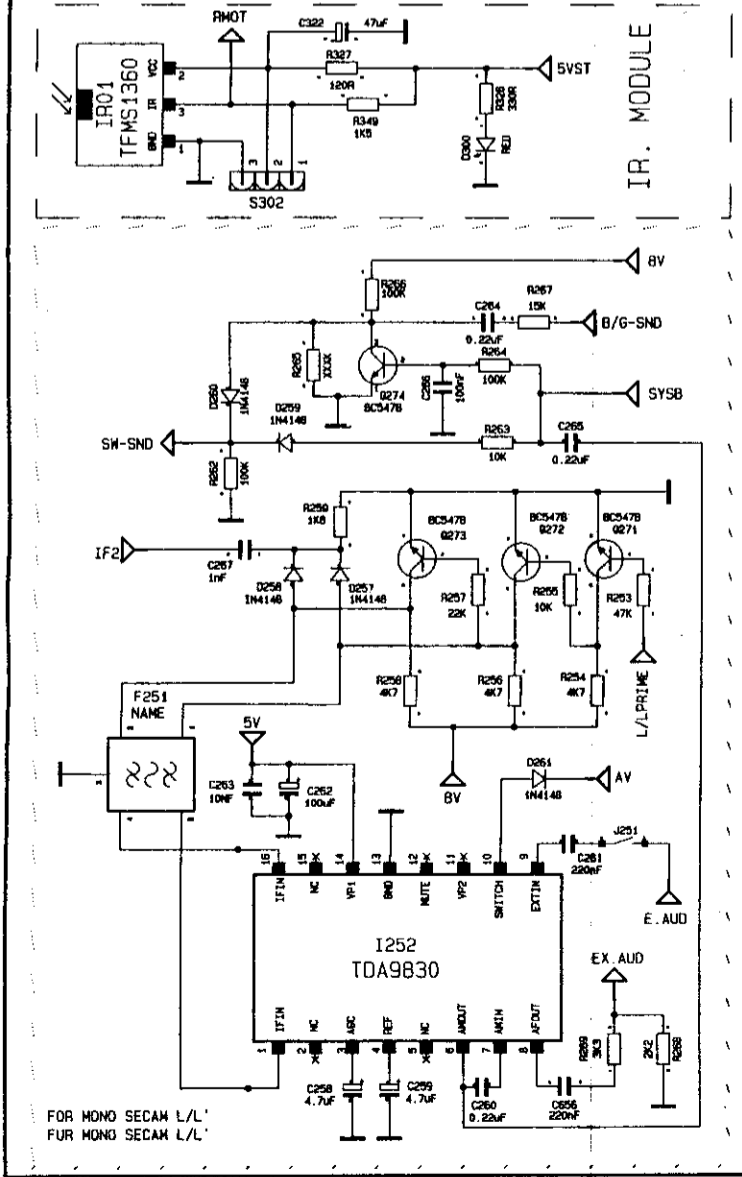
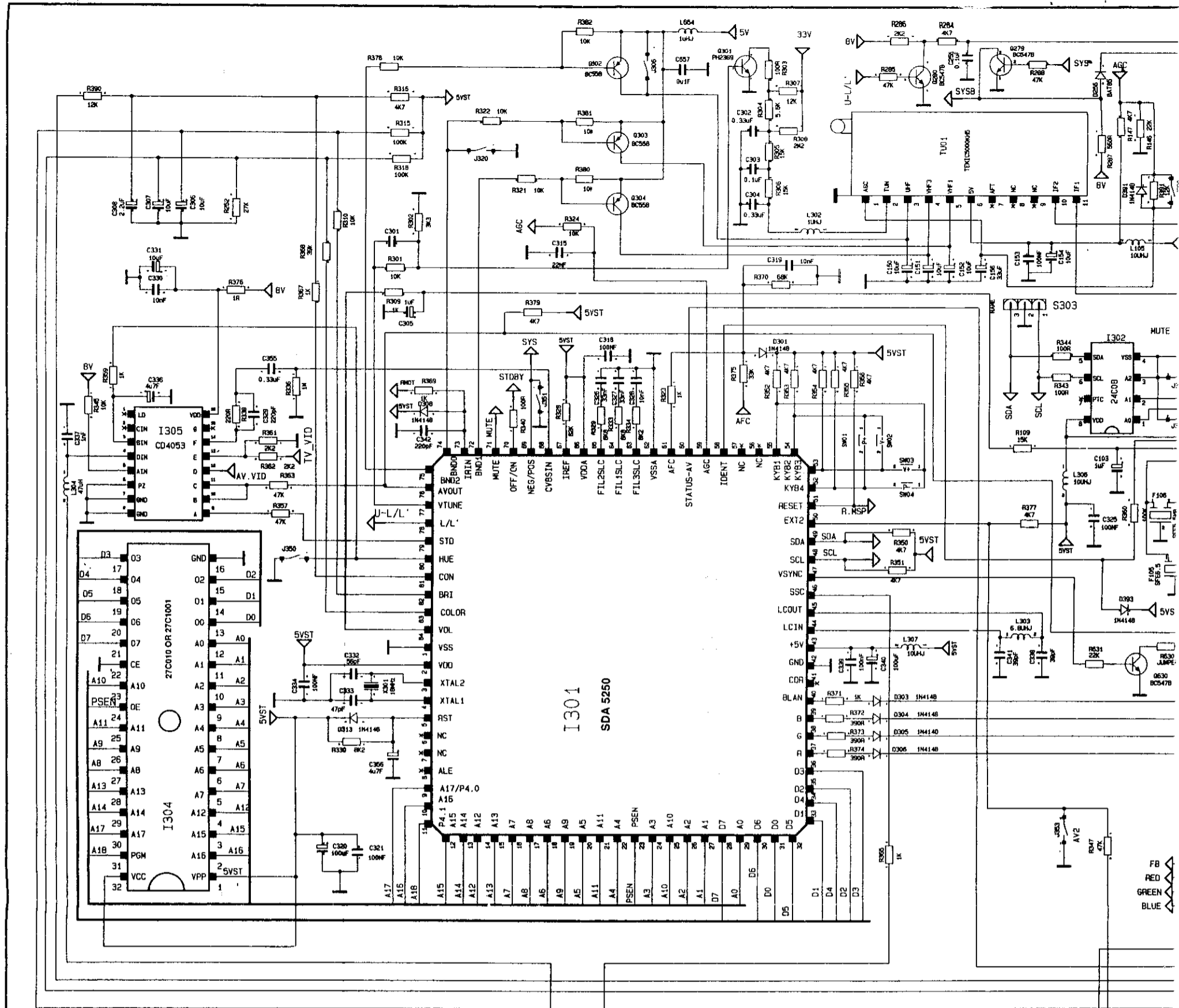

FOR MONO SECAM L/L
 FUR MONO SECAM L/L

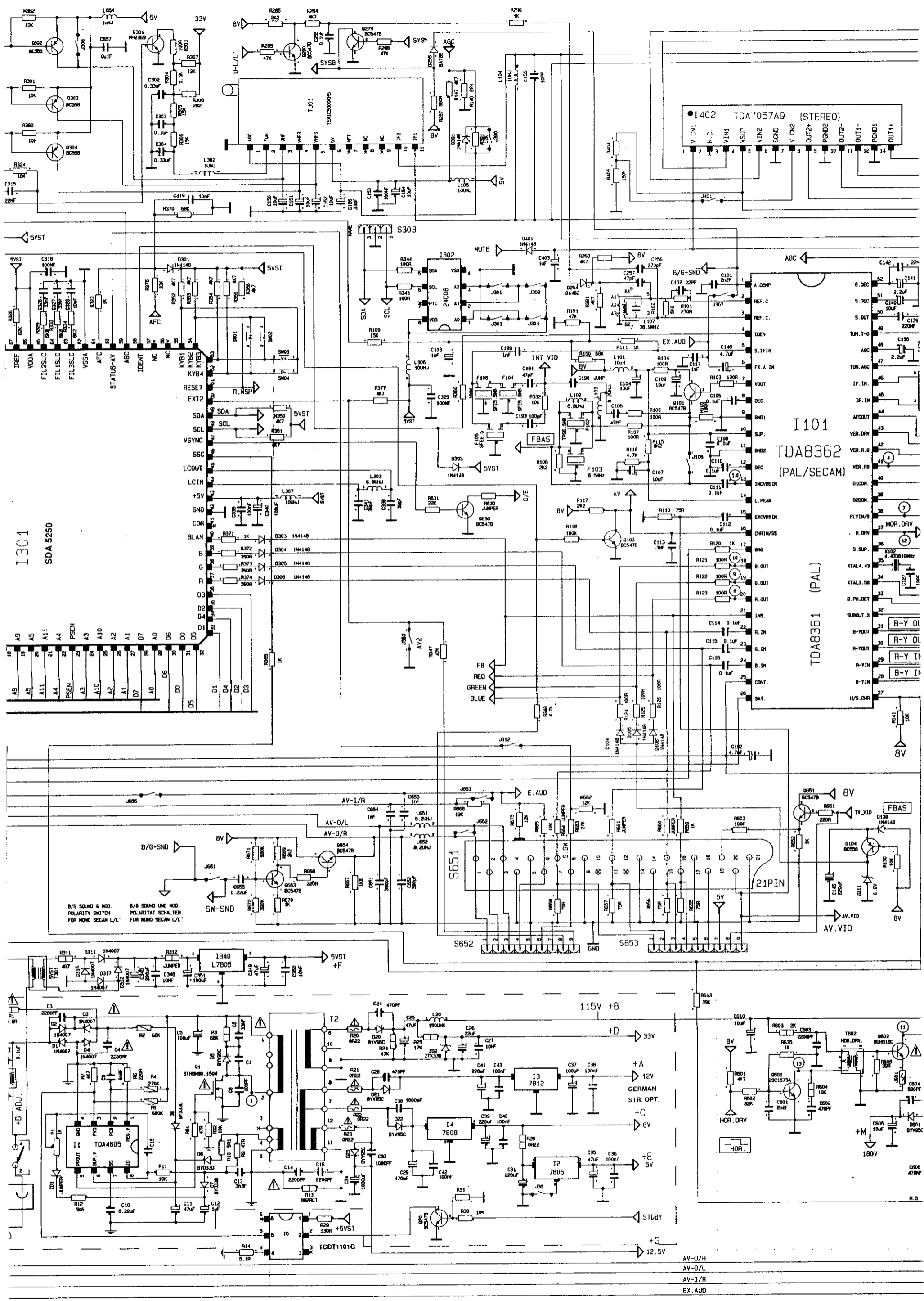

AV-0/R
AV-0/L
AV-1/R
EX. AUD

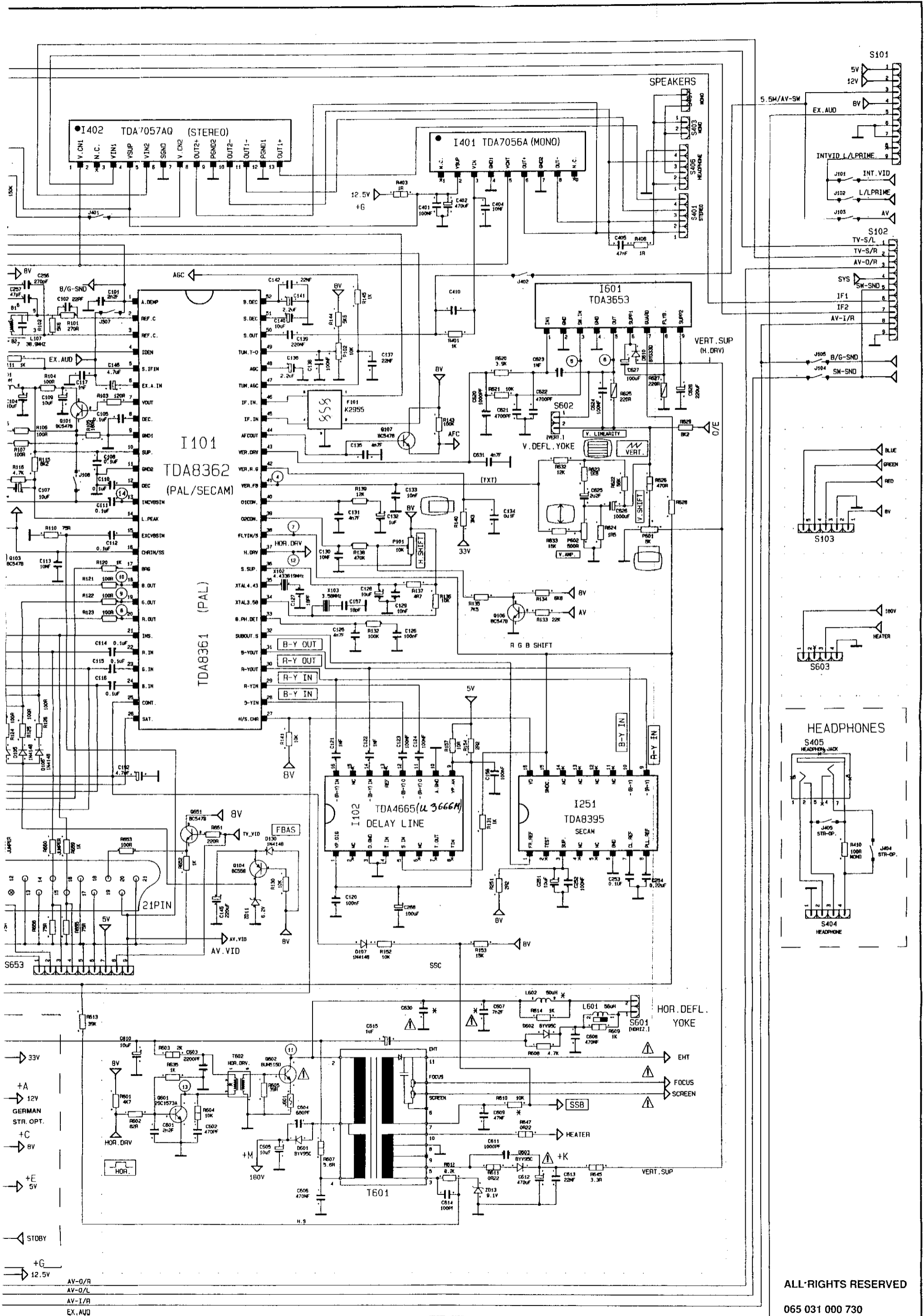

ALL RIGHTS RESERVED
065 031 000 730

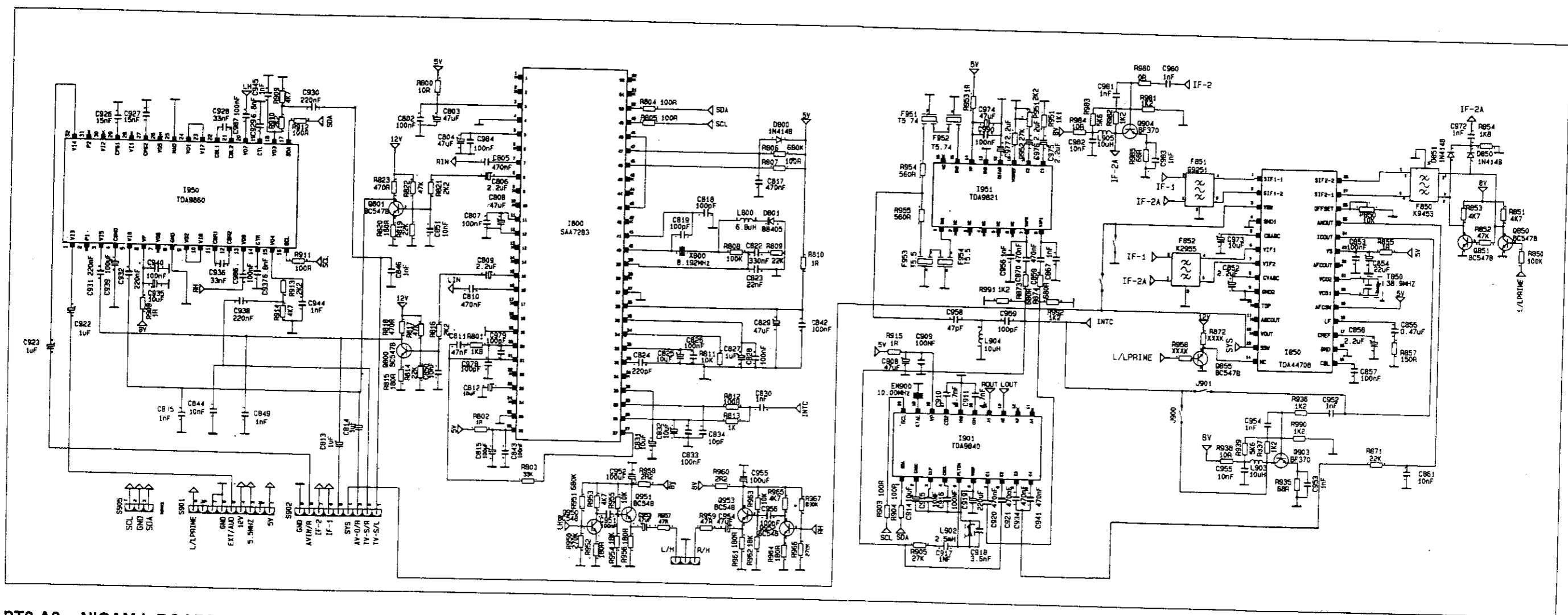

PT2 A2 + NICAM L BOARD CIRCUIT DIAGRAM / PT2 A2 + NICAM L BAUSTEIN SCHALTUNGSPLAN /
 SCHEMA DU CIRCUIT PT2 A2 + NICAM L

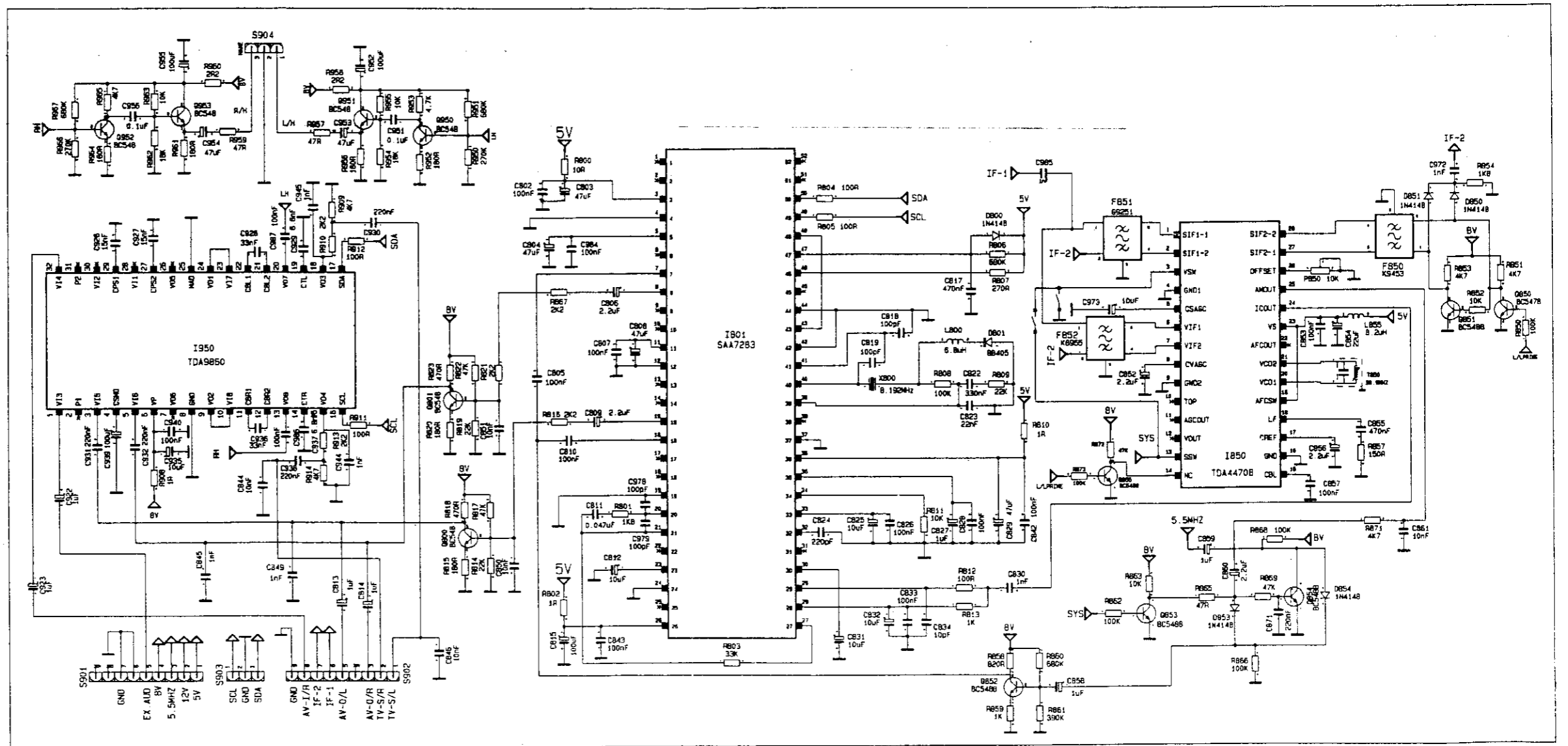

PT2 NICAM L BOARD CIRCUIT DIAGRAM / PT2 NICAM L BAUSTEIN SCHALTUNGSPLAN /
 SCHEMA DU CIRCUIT NICAM L

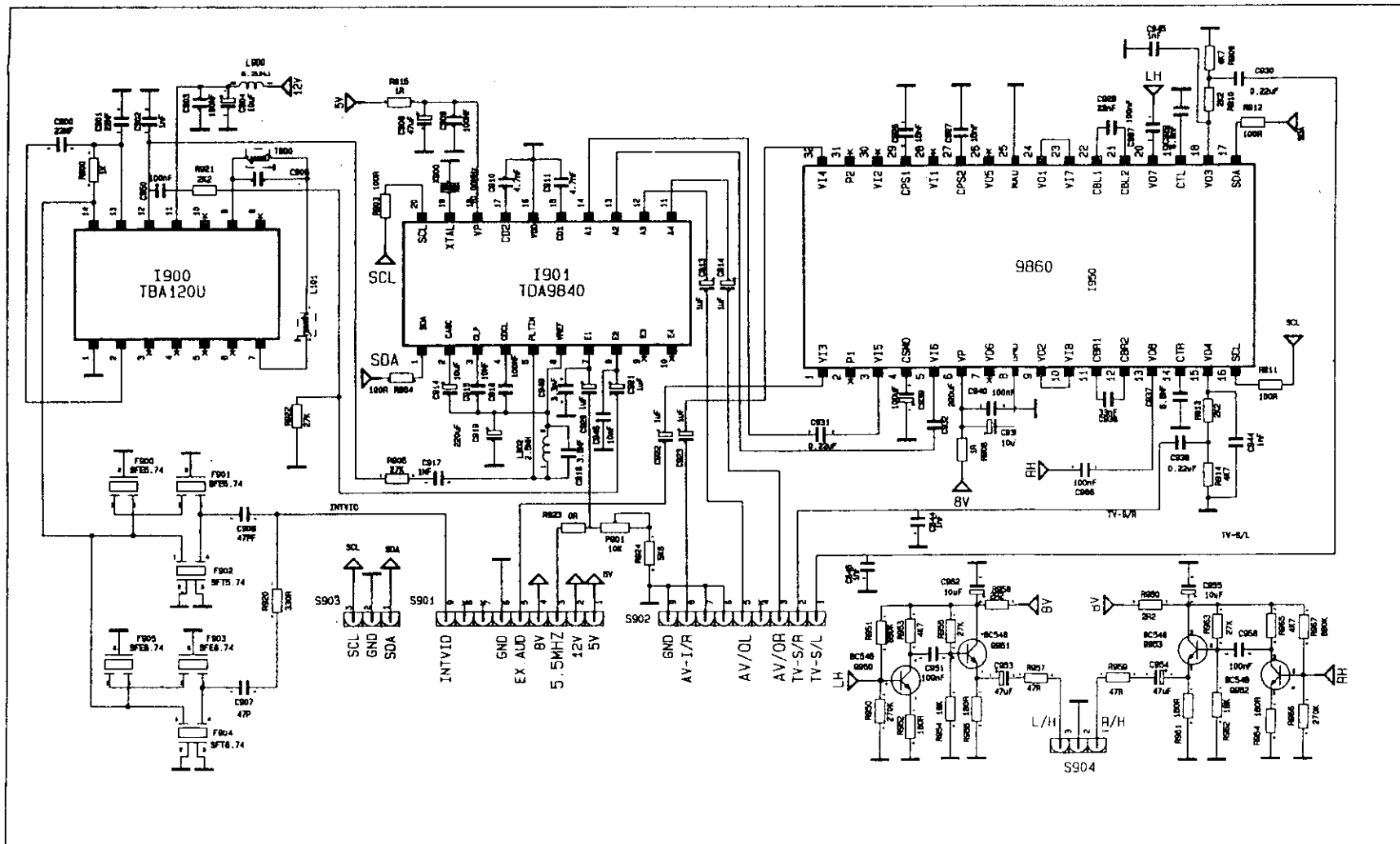

PT2 GERMAN STEREO BOARD CIRCUIT DIAGRAM / PT2 GERMAN STEREO BAUSTEINSCHALTUNGSPLAN /
 SCHEMA DU CIRCUIT GERMAN STEREO

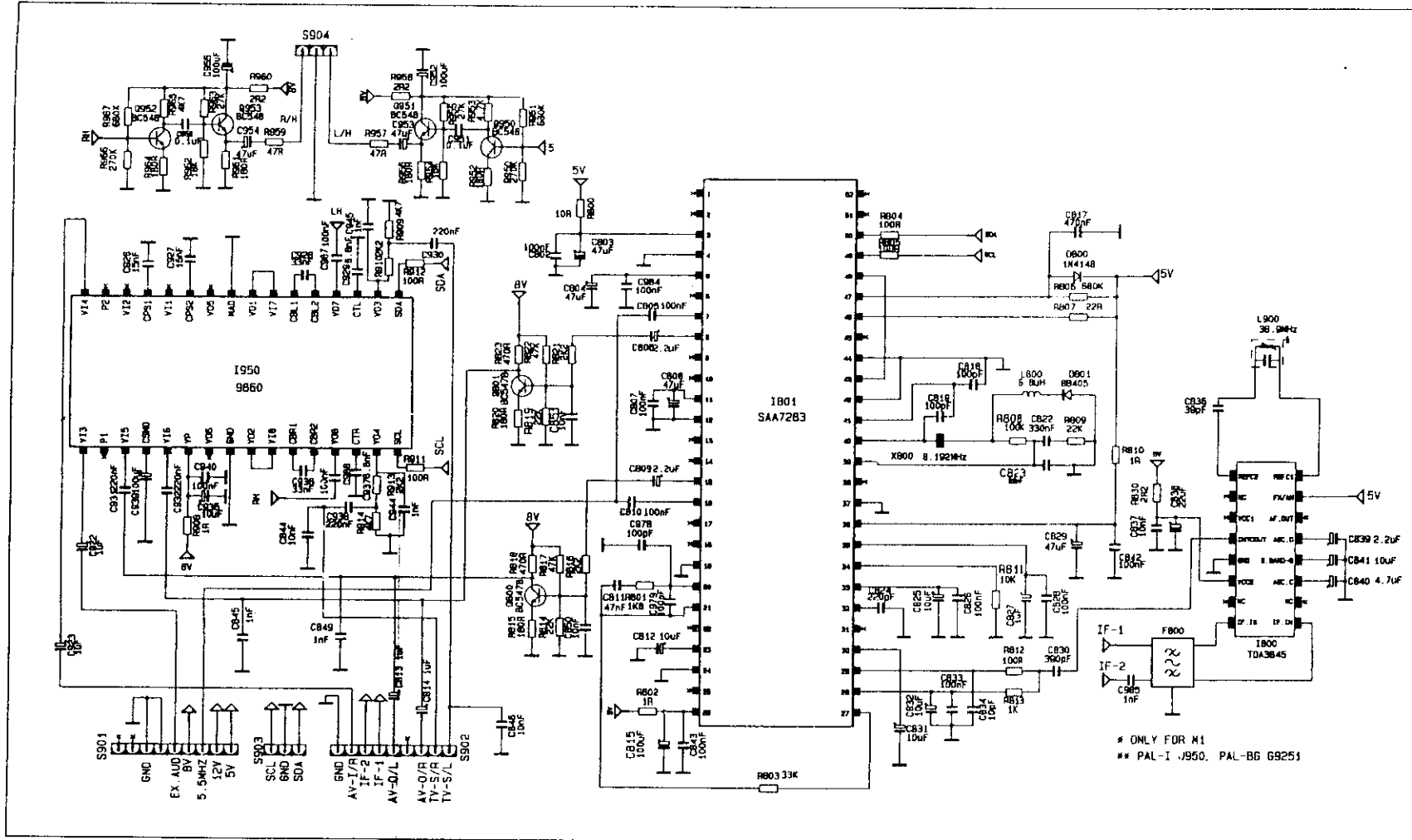

PT2 NICAM STEREO BOARD CIRCUIT DIAGRAM / PT2 NICAM STEREO BAUSTEIN SCHALTUNGSPLAN /
 SCHEMA DU CIRCUIT NICAM STEREO

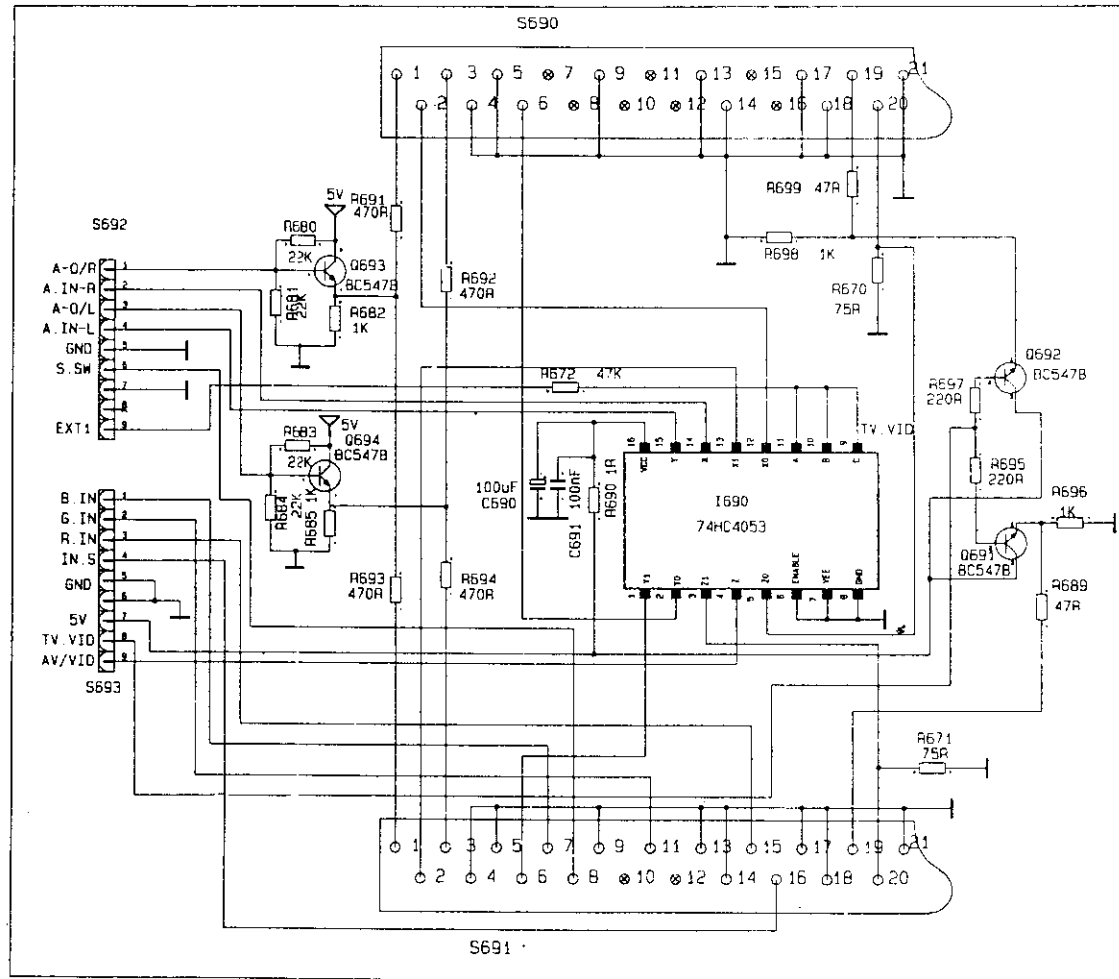

DOUBLE SCART BOARD CIRCUIT DIAGRAM / DOPPEL - SCART BAUSTEIN SCHALTUNGSPLAN /
 SCHEMA DU CIRCUIT DE LA DOUBLE PRISE PERITELLE

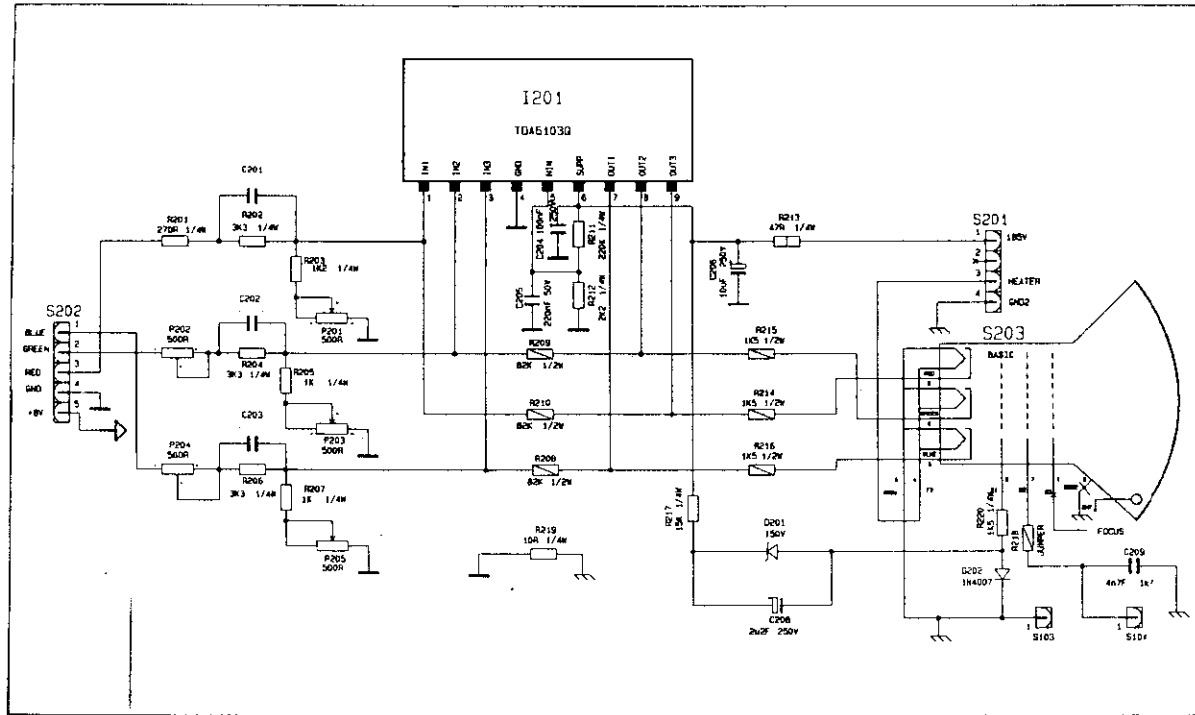

TDA 6103 CRT BOARD CIRCUIT DIAGRAM / TDA 6103 CRT BAUSTEIN SCHALTUNGSPLAN /
 SCHEMA DU CIRCUIT TDA 6103

OSCILLOSCOPE SHAPES/OSZILLOGRAMME/COURBES DE L' OSCILLOSCOPE

1) 5 usn/div 100 volt/div

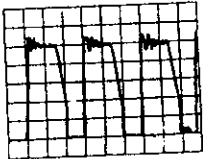

Q1'in Drain'i

2) 20 usn/div 2volt/div

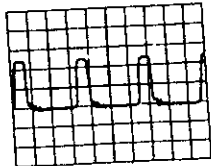

I 301 pin 46

3) 5m sn/div 2volt/div

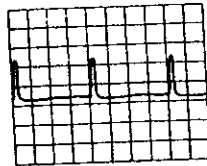

I 301 pin 47

4) 5 msn/div 0,5 volt/div

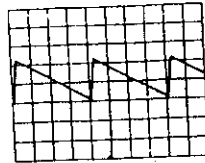

I 101 pin 41

5) 5 msn/div 1 volt/div

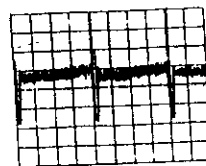

I 601 pin 3

6) 5 msn/div 20 volt/div

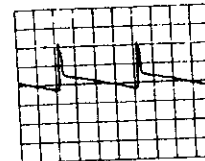

I 601 pin 5

7) 20 usn/div 2 volt/div

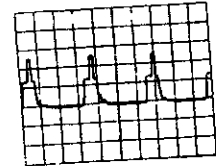

I 101 pin 38

8) 20 usn/div 2 volt/div

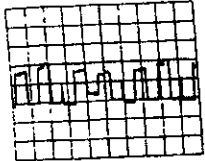

I 101 pin 20

9) 20 usn/div 2 volt/div

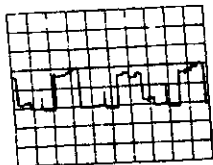

I 101 pin 19

10) 10 usn/div 2 volt/div

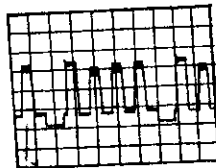

I 101 pin 18

11) 10 usn/div 250 volt/div

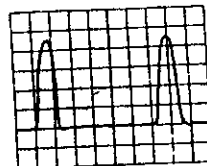

Q602'in Kollektörü

12) 10 usn/div 0.2 volt/div

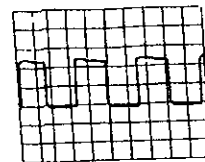

I 101 pin 37

13) 20 usn/div 50 volt/div

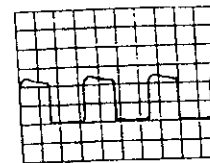

Q601'in Kollektörü

14) 20 usn/div 1 volt/div

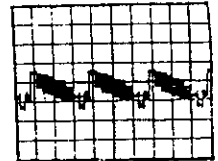

I 101 pin 13

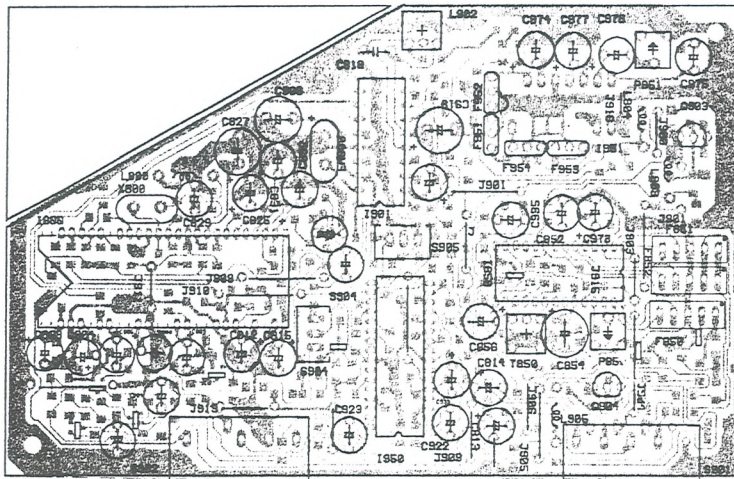

PT2 A2 + NICAM L BOARD / PT2 A2 + NICAM L BAUSTEIN /
CIRCUIT IMPRIME DU PT2 A2 + NICAM L

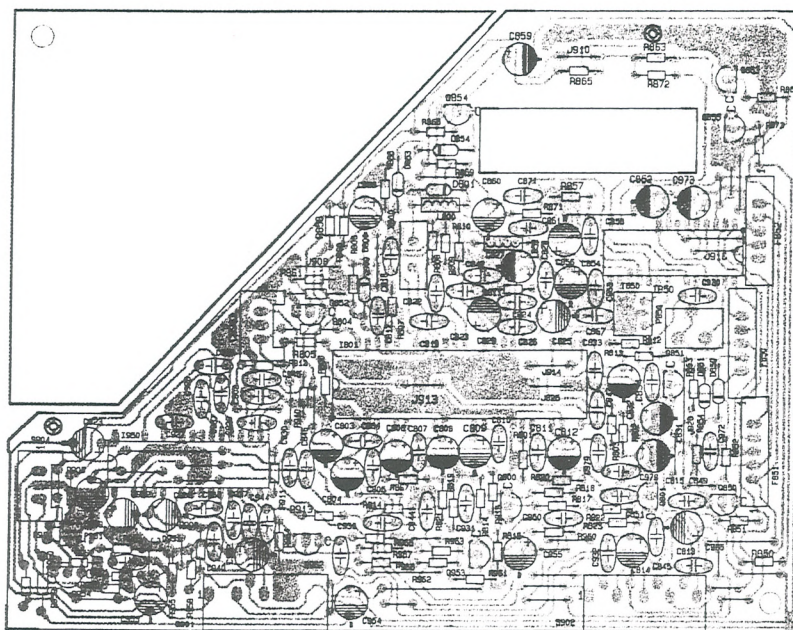

PT2 NICAM L BOARD / PT2 NICAM L BAUSTEIN / CIRCUIT IMPRIME DU PT2 NICAM L

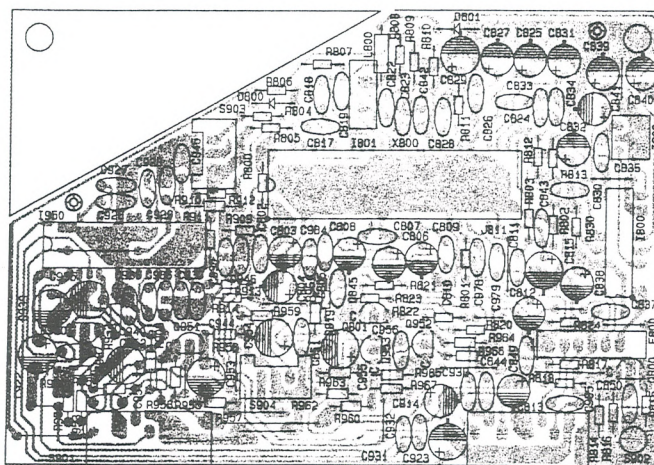

PT2 NICAM STEREO BOARD / PT2 NICAM STEREO BAUSTEIN /
CIRCUIT IMPRIME DU PT2 NICAM STEREO

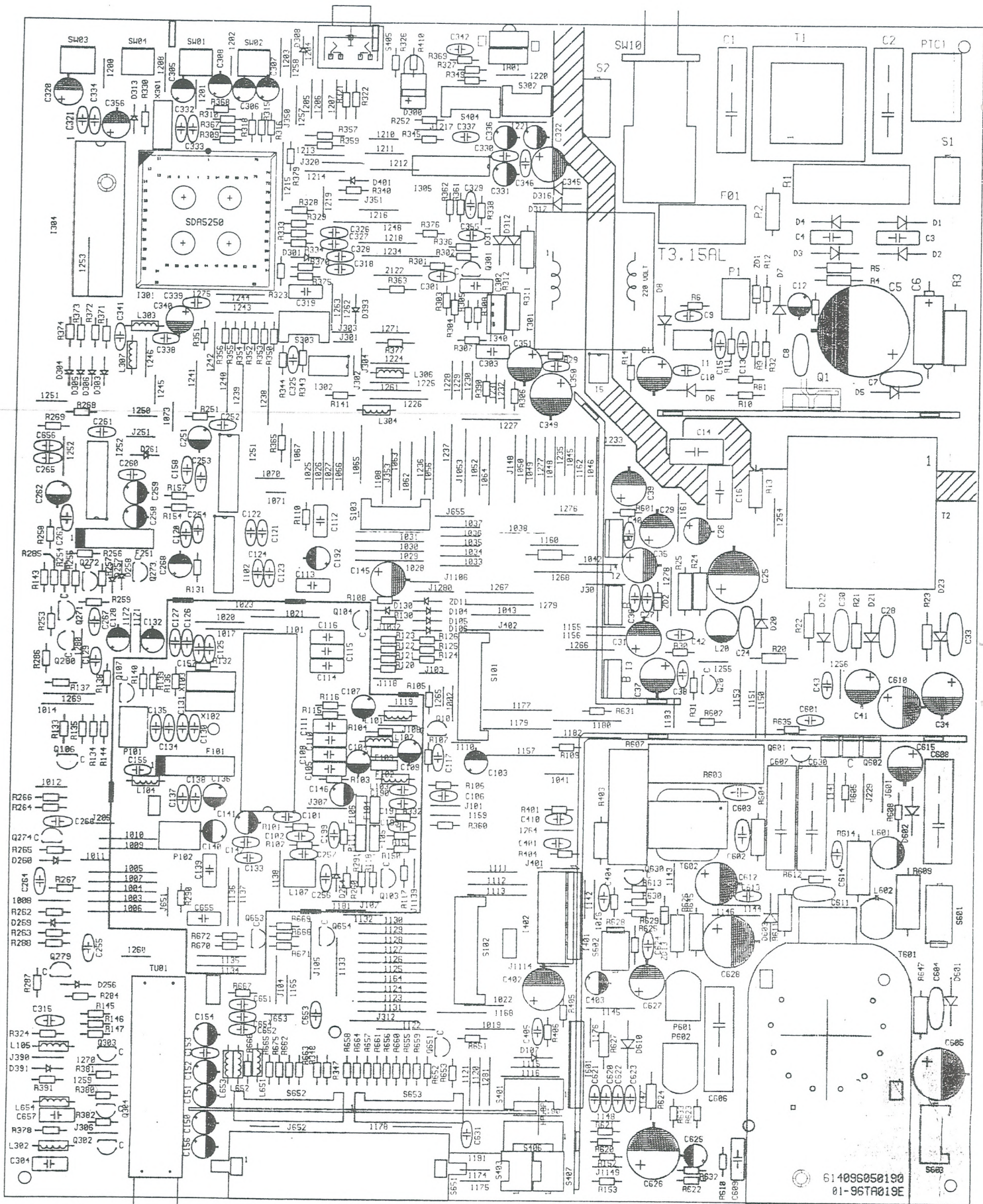

PT2 MAIN CHASSIS BOARD / PT2 CHASSISPLATE / CIRCUIT IMPRIME DU CHASSIS PRINCIPAL PT2

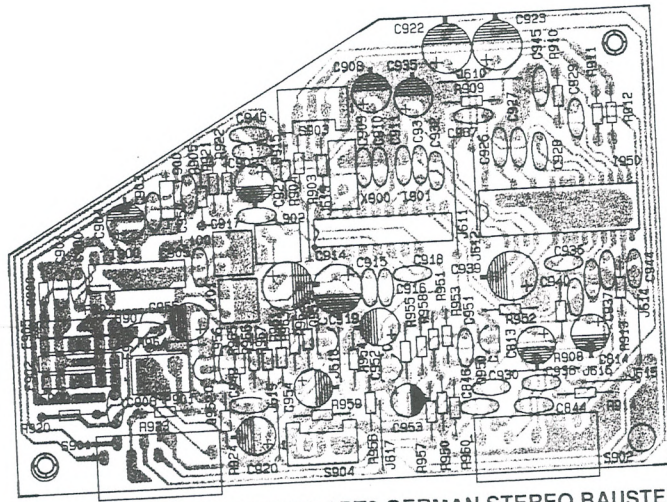

PT2 GERMAN STEREO BOARD / PT2 GERMAN STEREO BAUSTEIN /
CIRCUIT IMPRIME DU PT2 GERMAN STEREO

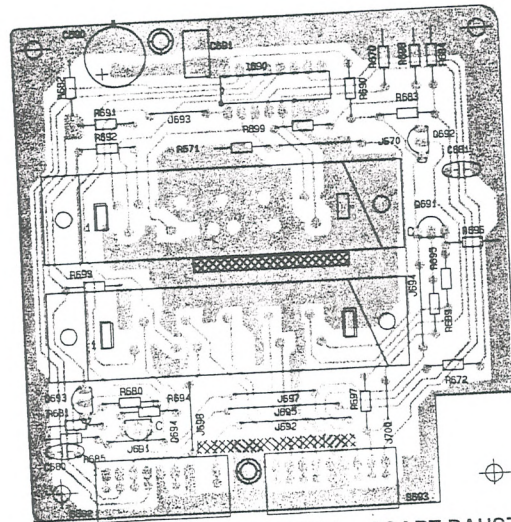

DOUBLE SCART BOARD / DOPPEL - SCART BAUSTEIN /
CIRCUIT IMPRIME DE LA DOUBLE PRISE PERITELLE

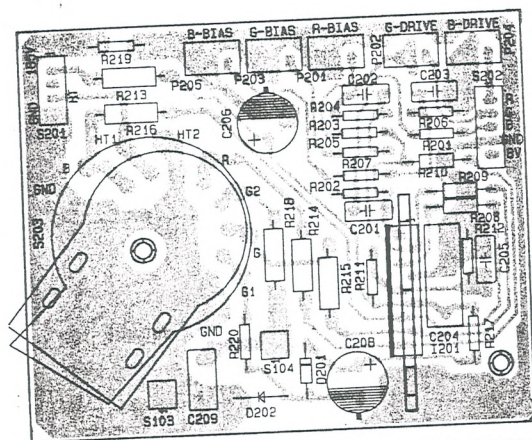

TDA 6103 CRT BOARD / TDA 6103 CRT BAUSTEIN /
CIRCUIT IMPRIME DU CRT TDA 6103