

DENON

Hi-Fi Personal Component System

SERVICE MANUAL

PERSONAL COMPONENT SYSTEM

UNIT No. UDRA-70 (MW LW FM Stereo Receiver)

UNIT No. UDR-70 (Cassette Tape Deck)

UNIT No. UCD-70 (Compact Disc Player)

D70 Aho

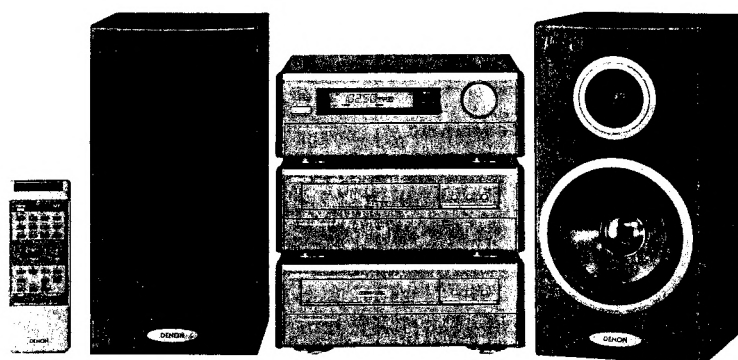

The D-70 Personal Component System consists of the following:

Receiver Section	UDRA-70
Remote Control Unit	RC-142
Cassette Deck Section	UDR-70
CD Section	UCD-70
Speaker Section	USC-70

MAIN FEATURES

- **30 FM/AM station random preset tuner**
 - * Random presetting makes for easy operation and will come in handy when the FM stations increases in the future.
- **Power amplifier designed for quality sound**
 - * 30W + 30W high quality power amplifier.
- **SDB control**
 - * Super dynamic bass control for clear low bass sound.
- **Super linear converter and high performance digital filter**
 - * DENON's unique systems for preventing loss of CD sound quality create an excellent sound field.
- **Editing circuit included**
 - * When performing edited recording onto tapes, tracks can be selected automatically so that the blank space on the tape is minimum.
- **Dolby B, C N.R**
 - * For playback and recording with high quality sound.
- **CD SRS circuit**
 - * CDs can be recorded at the touch of a button.
- **Easy-to-use remote control unit**

Check that the following parts are included in the package aside from the main unit:

① Operating Instructions	1
② FM Antenna	1
③ AM Loop Antenna	1
④ Remote Control Unit	1
⑤ R6P/AA batteries	2
⑥ System Connector	2
⑦ FM Antenna adapter	1

NIPPON COLUMBIA CO., LTD.

**NOTE ON USE/HINWEISE ZUM GEBRAUCH/OBSERVATIONS RELATIVES A L'UTILISATION
NOTE SULL'USO/NOTAS SOBRE EL USO/ALVORENS TE GEBRUIKEN/OBSERVERA**

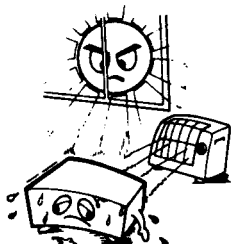

- Avoid high temperatures
Allow for sufficient heat dispersion when installed on a rack.
- Vermeiden Sie hohe Temperaturen
Beachten Sie, daß eine zureichende Luftzirkulation gewährleistet wird, wenn das Gerät auf ein Regal gestellt wird.
- Eviter des températures élevées
Tenir compte d'une dispersion de chaleur suffisante lors de l'installation sur une étagère.
- Evitate di esporre l'unità a temperature alte.
Assicuratevi che ci sia un'adeguata dispersione del calore quando installate l'unità in un mobile per componenti audio.
- Evite altas temperaturas
Permite la suficiente dispersión del calor cuando está instalado en la consola.
- Vermijd hoge temperaturen.
Zorg voor een degelijk hitteafvoer indien het apparaat op een rek wordt geplaatst.
- Undvik höga temperaturer.
Se till att det finns möjlighet till god värmeavledning vid montering i ett rack.



- Keep the set free from moisture, water, and dust.
- Halten Sie das Gerät von Feuchtigkeit, Wasser und Staub fern.
- Protéger l'appareil contre l'humidité, l'eau et la poussière.
- Tenete l'unità lontana dall'umidità, dall'acqua e dalla polvere.
- Mantenga el equipo libre de humedad, agua y polvo.
- Laat geen vochtigheid, water of stof in het apparaat binnendringen.
- Utsätt inte apparaten för fukt, vatten och damm.

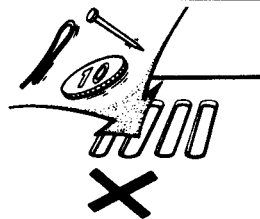

- Do not let foreign objects in the set.
- Keine fremden Gegenstände in das Gerät kommen lassen.
- Ne pas laisser des objets étrangers dans l'appareil.
- E' importante che nessun oggetto è inserito all'interno dell'unità.
- No deje objetos extraños dentro del equipo.
- Laat geen vreemde voorwerpen in dit apparaat vallen.
- Se till att främmande föremål inte tränger in i apparaten.

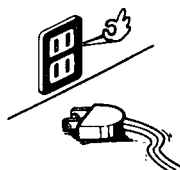

- Unplug the power cord when not using the set for long periods of time.
- Wenn das Gerät eine längere Zeit nicht verwendet werden soll, trennen Sie das Netzkabel vom Netzstecker.
- Débrancher le cordon d'alimentation lorsque l'appareil n'est pas utilisé pendant de longues périodes.
- Disinnestate il filo di alimentazione quando avete l'intenzione di non usare il filo di alimentazione per un lungo periodo di tempo.
- Desconecte el cordón de energía cuando no utilice el equipo por mucho tiempo.
- Neem altijd het netsnoer uit het stopcontact wanneer het apparaat gedurende een lange periode niet wordt gebruikt.
- Koppla ur nätkabeln om apparaten inte kommer att användas i lång tid.

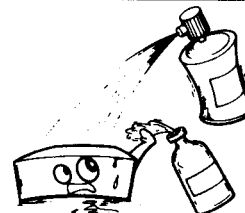

- Do not let insecticides, benzene, and thinner come in contact with the set.
- Lassen Sie das Gerät nicht mit Insektiziden, Benzin oder Verdünnungsmitteln in Berührung kommen.
- Ne pas mettre en contact des insecticides, du benzène et un diluant avec l'appareil.
- Assicuratevvi che l'unità non venga in contatto con insetticidi, benzolo o solventi.
- No permita el contacto de insecticidas, gasolina y diluyentes con el equipo.
- Laat geen insektenverdelgende middelen, benzine of verfverdunder met dit apparaat in contact komen.
- Se till att inte insektsmedel på spraybruk, bensen och thinner kommer i kontakt med apparatens hölje.

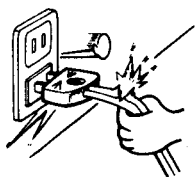

- Handle the power cord carefully.
Hold the plug when unplugging the cord.
- Gehen Sie vorsichtig mit dem Netzkabel um.
Halten Sie das Kabel am Stecker, wenn Sie den Stecker herausziehen.
- Manipuler le cordon d'alimentation avec précaution.
Tenir la prise lors du débranchement du cordon.
- Maneggiare il filo di alimentazione con cura.
Agite per la spina quando scollegate il cavo dalla presa.
- Maneje el cordón de energía con cuidado.
Sostenga el enchufe cuando desconecte el cordón de energía.
- Hantera het netsnoer voorzichtig.
Houd het snoer bij de stekker vast wanneer deze moet worden aan- of losgekoppeld.
- Hantera nätkabeln varsamt.
Håll i kabeln när den kopplas från eluttaget.

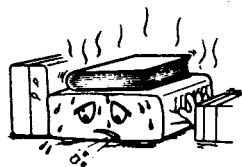

*(For sets with ventilation holes)

- Do not obstruct the ventilation holes.
- Die Belüftungsöffnungen dürfen nicht verdeckt werden.
- Ne pas obstruer les trous d'aération.
- Non coprite i fori di ventilazione.
- No obstruya los orificios de ventilación.
- De ventilatieopeningen mogen niet worden beblokkeerd.
- Täpp inte till ventilationsöppningarna.



- Never disassemble or modify the set in any way.
- Versuchen Sie niemals das Gerät auseinander zu nehmen oder auf jegliche Art zu verändern.
- Ne jamais démonter ou modifier l'appareil d'une manière ou d'une autre.
- Non smontate mai, nè modificate l'unità in nessun modo.
- Nunca desarme o modifique el equipo de ninguna manera.
- Nooit dit apparaat demonteren of op andere wijze modificeren.
- Ta inte isär apparaten och försök inte bygga om den.

GENERAL SECTION

MAIN SPECIFICATIONS

- **Receiver Section (UDRA-70)**
Amplifier
Practical maximum output: 30W + 30W (40 Hz ~ 20 kHz)
Bass adjustment: 100 Hz ±8 dB
Treble adjustment: 10 kHz ±8 dB
SDB (Super Dynamic Bass): 80 Hz, +8 dB
Included jacks: PHONO (MM Cartridge) Input jacks (input sensitivity 2.5mV/47 kohms)
 DAT/VCR: Input jacks output jacks for recording
 (input sensitivity 150mV/75 kohms)
 Headphones jack: 3.5 mm mini-size jack

- **Tuner**
Reception frequency range: FM: 87.50 MHz ~ 108.00 MHz
 MW: 522 kHz ~ 1611 kHz
 LW: 153 kHz ~ 279 kHz
Reception sensitivity: FM: 1.5 µV, 75 ohms (SN ratio 30 dB)
 MW: 20 µV (SN ratio 20 dB)
 LW: 35 µV (SN ratio 20 dB)
FM stereo separation: 35 dB (1 kHz)
Max. external dimensions: 250 (W) × 96 (H) × 354 (D) mm (9-27/32" × 3-25/32" × 13-15/16")
Weight: 5.3kg (11 lbs 11 oz)
Power supply: AC 220V, 50 Hz (for Europe model)
 AC240V, 50 Hz (for U.K. model)
Power consumption: 100W

- **CD Player Section (UDCM-70)**
Wow & flutter: Below measurable limits (±0.001% W.Peak)
Playing time: 60 minutes/one side
Sampling frequency: 44.1 kHz
Light source: Semiconductor
Max. external dimensions: 250 (W) × 96 (H) × 312 (D) mm (9-27/32" × 3-26/32" × 12-9/32")
Weight: 2.8kg (6 lbs 3 oz)

- **Cassette Deck Section (UDR-70)**
Type: Horizontal 4-track, 2-channel auto reverse stereo cassette deck
Heads: 1 hard permalloy head for recording and playback, 1 double-gap ferrite head for erasing
Tape speed: 4.75 cm/s
Included circuits: Dolby B and C
Wow & flutter: 0.06% or less (W.R.M.S.)
Usable tapes: Normal, chrome and metal tapes
Max. external dimensions: 250 (W) × 96 (H) × 312 (D) mm (9-27/32" × 3-25/32" × 12-9/32")
Weight: 3.2 kg (7 lbs 1 oz)

- **Remote Control Unit (RC-142)**
Type: Infrared pulse
Number of buttons: 38
Max. external dimensions: 65 (W) × 175 (H) × 20 (D) mm (2-9/16" × 6-57/64" × 25/32")
Weight: 130 g (approx. 5 oz) (including batteries)

* Maximum dimensions include controls, jacks, and covers. (W) = width, (H) = height, (D) = depth

• For improvement purposes, specifications and functions are subject to change without advanced notice.

Only discs with the mark at the right can be played on this system.



Dolby noise reduction manufactured under license from Dolby Laboratories Licensing Corporation. "DOLBY" and the double-D symbol  are trademarks of Dolby Laboratories Licensing Corporation.

	D-70 for Europe model	D-70 for U.K. model
Receiver Unit	UDRA-70	UDRA-70
Cassette Deck Unit	UDR-70	UDR-70
CD Player Unit	UCD-70	UCD-70
(Master) Carton	501 1582 004	501 1582 004
Control Card Base	513 1389 006	513 1389 006
Thermal Carbon Film	513 1349 004	513 1349 004

GENERAL SECTION

CONNECTIONS

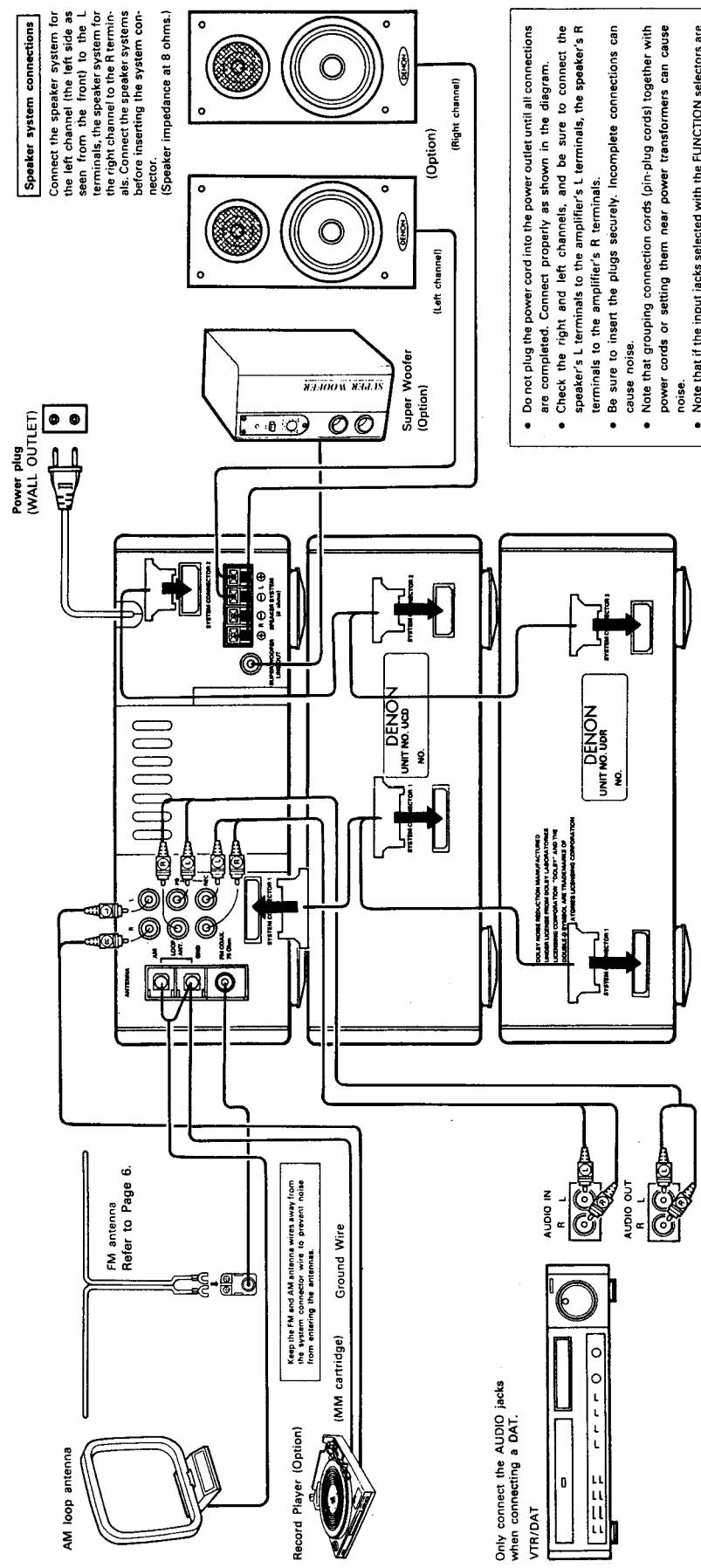

Speaker system connections
 Connect the speaker system for the left channel (the left side as seen from the front) to the L terminals, the speaker system for the right channel to the R terminals. Connect the speaker systems before inserting the system connector. (Speaker impedance at 8 ohms.)

- Do not plug the power cord into the power outlet until all connections are completed. Connect properly as shown in the diagram.
- Check the right and left channels, and be sure to connect the speaker's L terminals to the amplifier's L terminals, the speaker's R terminals to the amplifier's R terminals.
- Be sure to insert the plugs securely. Incomplete connections can cause noise.
- Note that grouping connection cords (pin-plug cords) together with power cords or setting them near power transformers can cause noise.
- Note that if the input jacks selected with the FUNCTION selectors are open (if nothing is connected), the sound may leak to another component connected to different input jacks.

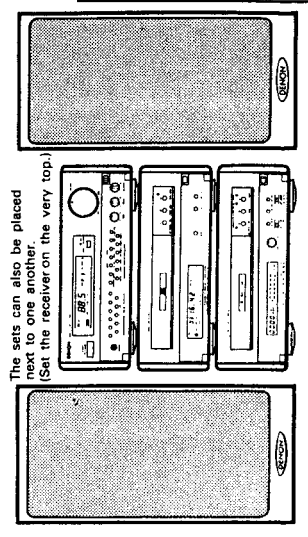

The sets can also be placed next to one another (Set the receiver on the very top.)

NOTE
 This system includes digital circuitry, so it may cause problems with the colors on a TV. If so, turn the system's power switch off.

Connecting the System Connector Cord

When connecting the system connector cord, press the sides of the connector plug towards the middle and pull.



Note that disconnecting by pulling on the cord can damage it.

Only connect the AUDIO jacks when connecting a DAT. VTR/DAT

GENERAL SECTION

REMOTE CONTROL UNIT

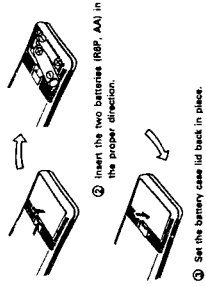

The remote control unit can be used 2-3 meters from the receiver's sensor, but this distance will be shorter if there are obstacles in the way or if the remote control unit is operated from an angle.

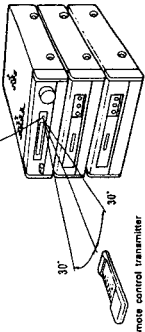

"EB" appears at the upper left corner of the tuner's display when signals are received.

- Be careful that the remote control sensor is not exposed to direct sunlight or strong light from lighting fixtures. If it is, the remote control unit may not work.
- When adjusting the volume from the remote control unit, the volume will stop changing if the remote control transmitter is moved away from the remote control sensor. Press the button again to continue changing the volume.

ANTENNA CONNECTIONS

Connecting the Included Antennas

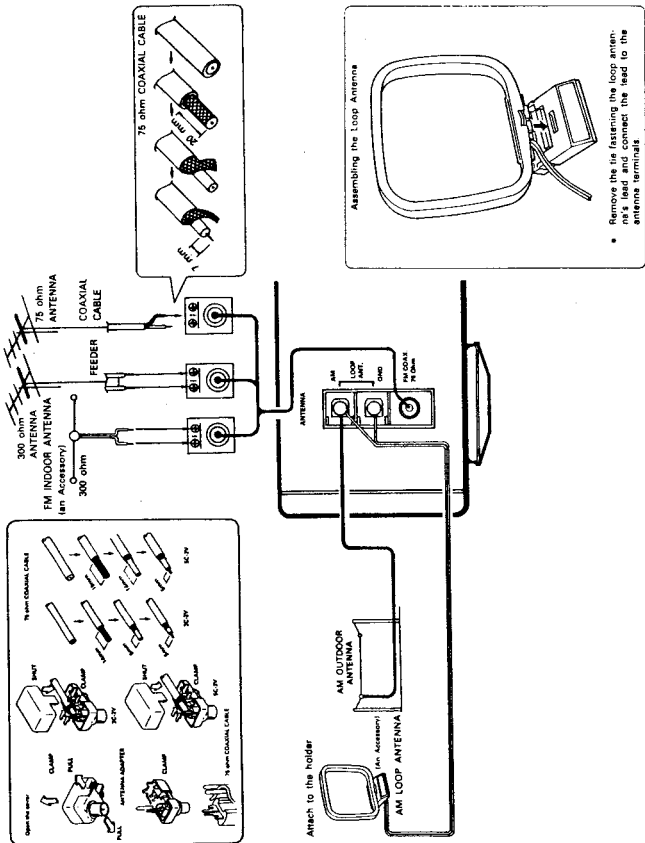

Button Names and Functions

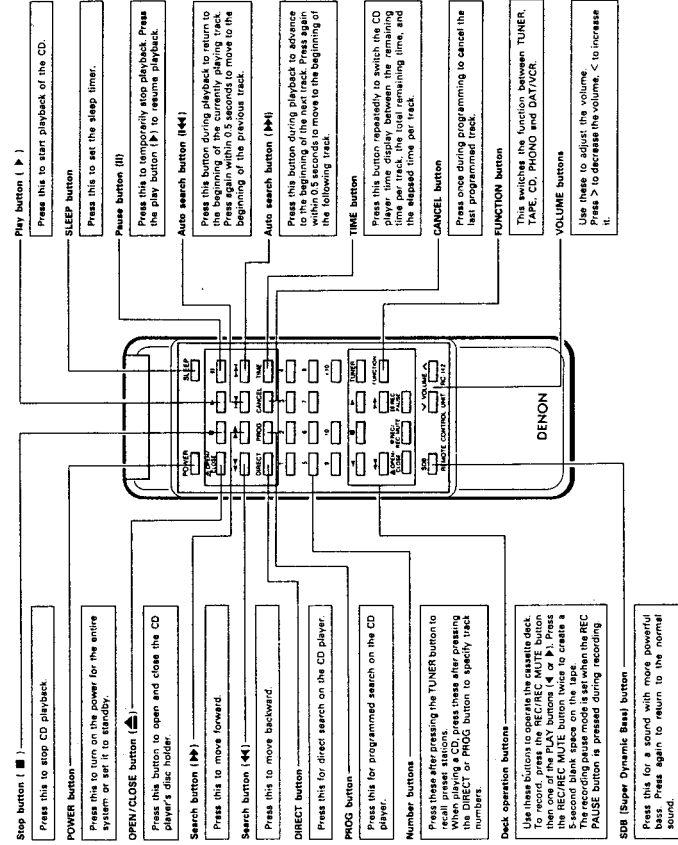

RECEIVER SECTION

PART NAMES AND FUNCTIONS

RECEIVER

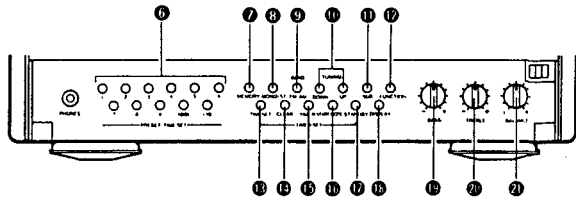
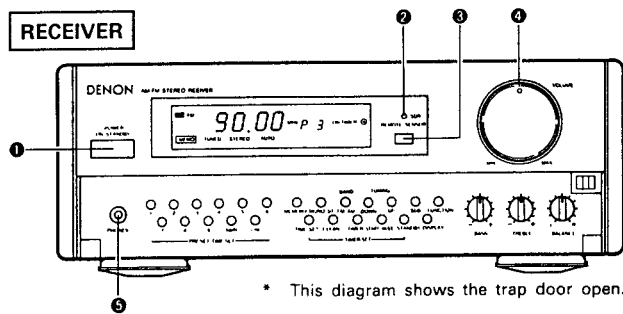

* This diagram shows the trap door open.

- 1 POWER switch**
Press this switch once to turn on the power and the display. The displays on the CD player and cassette deck also light. The CD player's play indicator does not light. The cassette deck's direction of play indicator lights.
- 2 SDB (Super Dynamic Bass) indicator**
This lights when the SDB function is turned on with the SDB button.
- 3 REMOTE SENSOR**
- 4 VOLUME control**
Use this control to adjust the volume. Turn clockwise (↻) to increase the volume, counterclockwise (↻) to decrease it.
- 5 PHONES jack**
When using headphones, plug them in here. The sound from the speakers is cut when headphones are plugged in.
- 6 Number buttons for FM/AM presetting, time setting, etc.**
These are used to preset and recall AM and FM broadcasts, to set the time and timer, etc.
- 7 MEMORY button**
This button is used when presetting AM and FM stations.
- 8 MONO/ST. (FM stereo mute/mono) selector button (For FM reception)**
STEREO mute: Use this mode to receive FM broadcasts in stereo. ("AUTO" appears on the display.)
The muting circuit is activated to cut noise between stations.
MONO: In this mode, FM broadcasts are received in monaural, regardless of whether they are broadcast in monaural or stereo. Set to the mono mode if there is much noise in the stereo mute mode (with "AUTO" displayed) or if the signals are weak.

- 9 BAND (FM/MW/LW) selector button**
The band switches between FM and MW, LW each time this button is pressed.
- 10 AUTO TUNING UP and DOWN buttons**
These are used to tune in MW, LW and FM stations, and for corrections when setting the time and timer.
- 11 SDB (Super Dynamic Bass) button**
Press this button for more powerful bass sound. Press again to turn the SDB function off.
- 12 FUNCTION selectors**
Use these to select the program source.
- 13 TIME SET button**
This is used when setting the timer and the current time, and when checking the timer settings, etc.
- 14 CLEAR button**
This is used to change the current time and the timer settings.
- 15 TIMER button**
This is used to set the timer.
- 16 Timer START MODE button**
Use this button to select the function when setting the timer.
- 17 Timer STANDBY button**
Press this button so that the timer will operate at the set times.
- 18 DISPLAY TIME/FUNCTION button**
Press this button to switch the display between the function and the time.
- 19 BASS control**
Use this to adjust the bass.
- 20 TREBLE control**
Use this to adjust the treble.
- 21 BALANCE control**
Use this to adjust the balance between the volume of the left and right channels. The volume is the same for the left and right channels when the control is at the center.

This button will not function when receiving MW and LW broadcasts.

RECEIVER DISPLAY

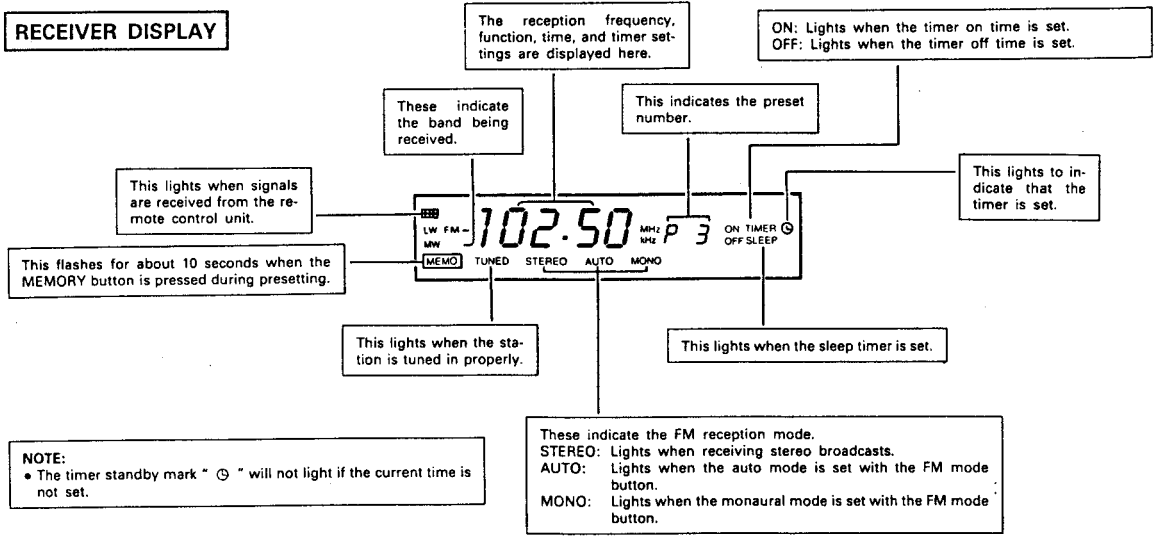

RECEIVER SECTION

REMOVAL OF EACH SECTION

(Follow this procedure in the reverse order when assembling.)

1. Removal of the top cover and the front panel assembly

- ① Remove the 5 screws which fasten the top cover.
- ② Remove the 2 screws which fasten the front panel.
- ③ Remove the volume control assembly in the direction of the arrow.
- ④ Remove the nut which fastens the volume knob. At this time, remove with care the connector which connects the amp unit assembly and the front panel side assembly.

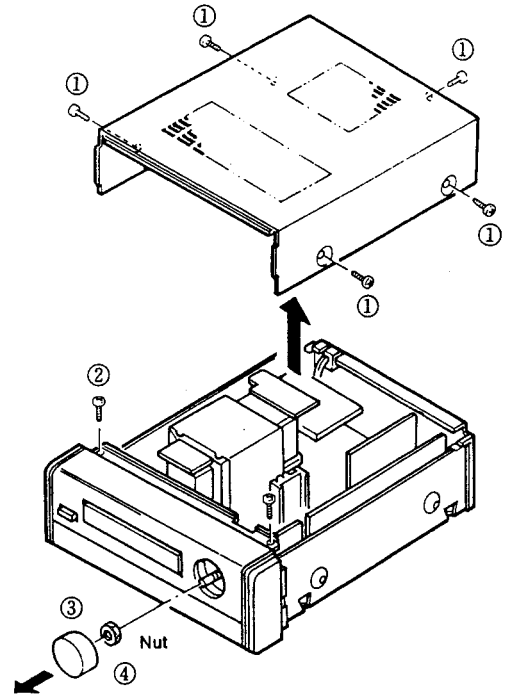
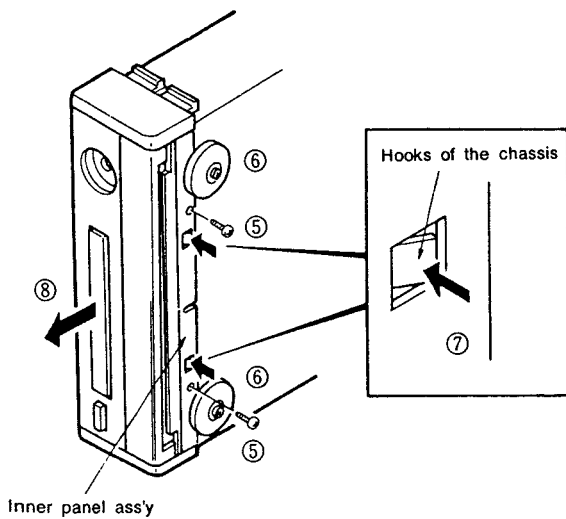

- ⑤ Stand the main unit as illustrated in the diagram and remove the 2 screws which fasten the inner panel assembly.
- ⑥ Slightly loosen the screws of the 2 front legs.
- ⑦ Remove the hooks of the chassis from the inner panel assembly.
- ⑧ Remove the front panel assembly in the direction of the arrow.

2. Removal of the printed wiring board assembly
DISPLAY UNIT ASSEMBLY (1U-2277-2)

- ⑨ Remove the 2 screws which fasten the tone board.
- ⑩ Remove the screw which fastens the headphone board.
- ⑪ Remove the 3 screws which fasten the display unit assembly.
- ⑫ Remove the hooks of the inner panel assembly from the display unit assembly.

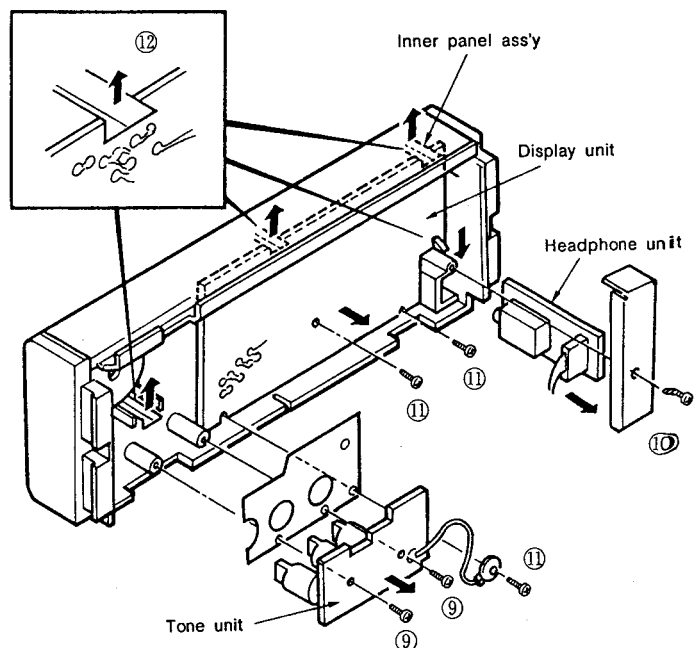

RECEIVER SECTION

JACK UNIT ASSEMBLY (1U-2278-2) and FUSE UNIT ASSEMBLY (not on the parts list)

- 13 Remove the 2 screws which fasten the jack unit assembly.
- 14 Remove the connector which connects the jack unit assembly and the amp unit assembly. (Press the main unit assembly down slightly.)
- 15 Remove the screw which holds the fuse unit assembly.
- 16 Remove the cord bush from the rear panel and remove the fuse unit assembly in the direction of the arrow.
- 17 Remove the 2 screws which fasten the radiator cover.

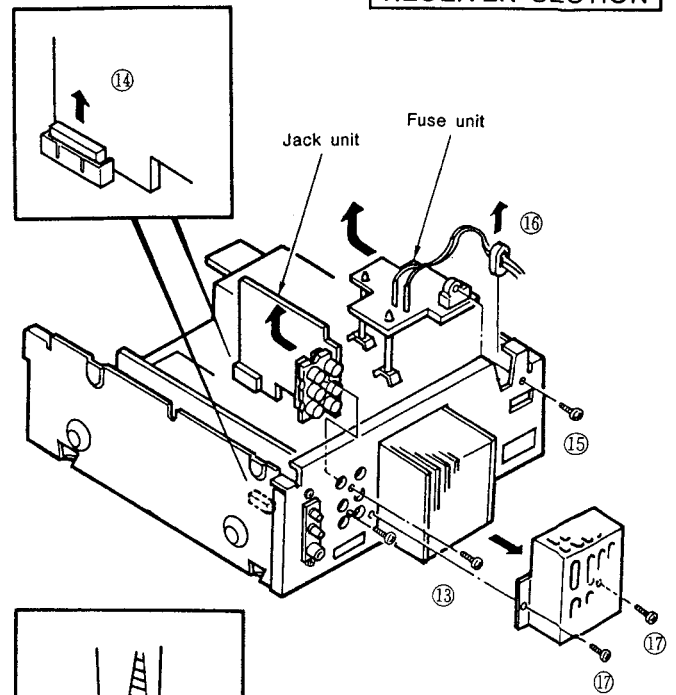

AMP UNIT ASSEMBLY (1U-2277-1)

- 18 Remove the 5 screws which fasten the amp unit assembly.
- 19 Remove the 2 screws which fastens the tuner unit assembly.
- 20 Remove the 4 screws which fasten the power transformer. Slide the power transformer in the direction of the arrow at this time.
- 21 Use radio pliers or another suitable tool to remove the PCB holder which fastens the amp unit assembly.

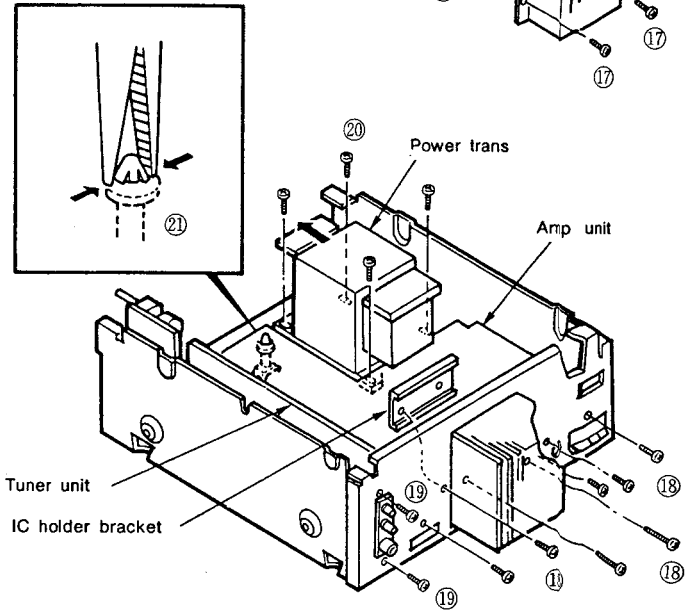

- 22 Remove the 4 screws which fasten the amp unit assembly.
- 23 Remove the amp unit assembly from the rear panel, then remove the amp unit assembly in the direction of the arrow.

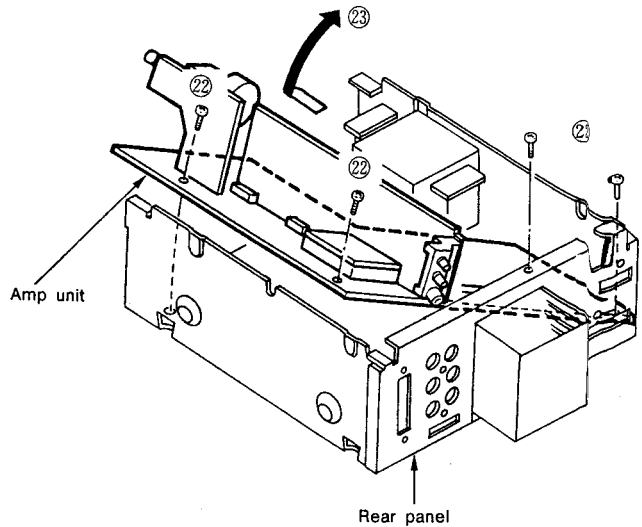

RECEIVER SECTION

BLOCK DIAGRAM
(TUNER SECTION)

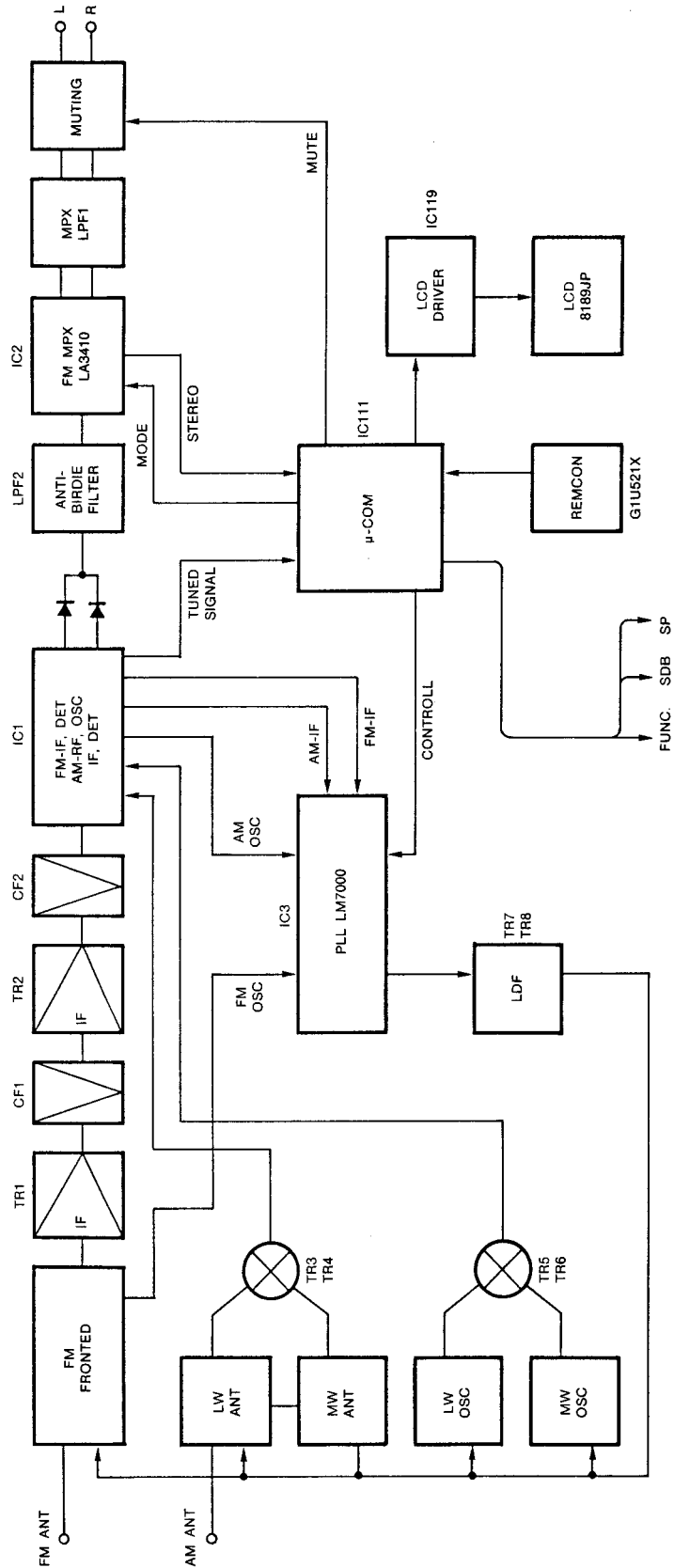

RECEIVER SECTION

(AMP SECTION)

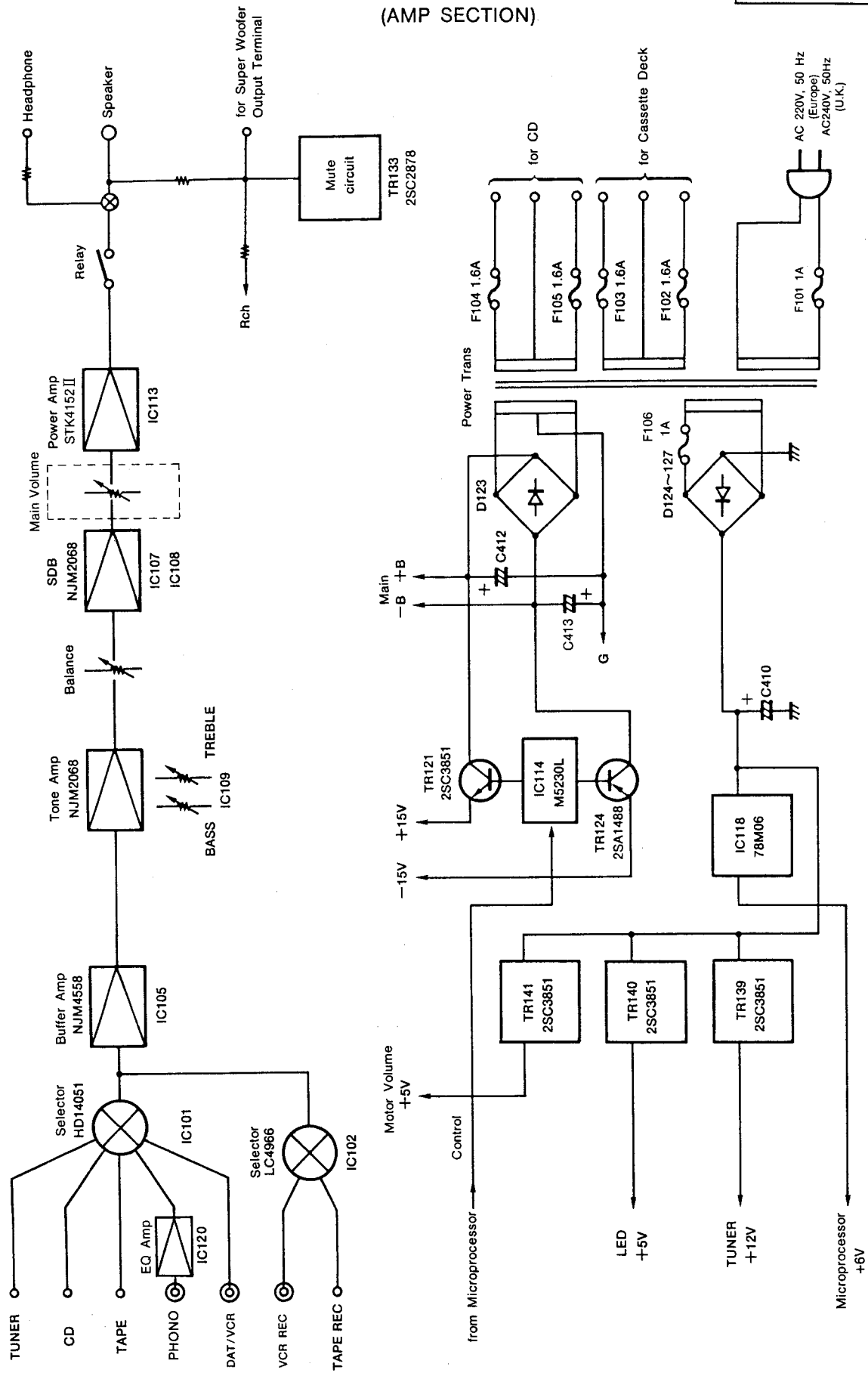

RECEIVER SECTION

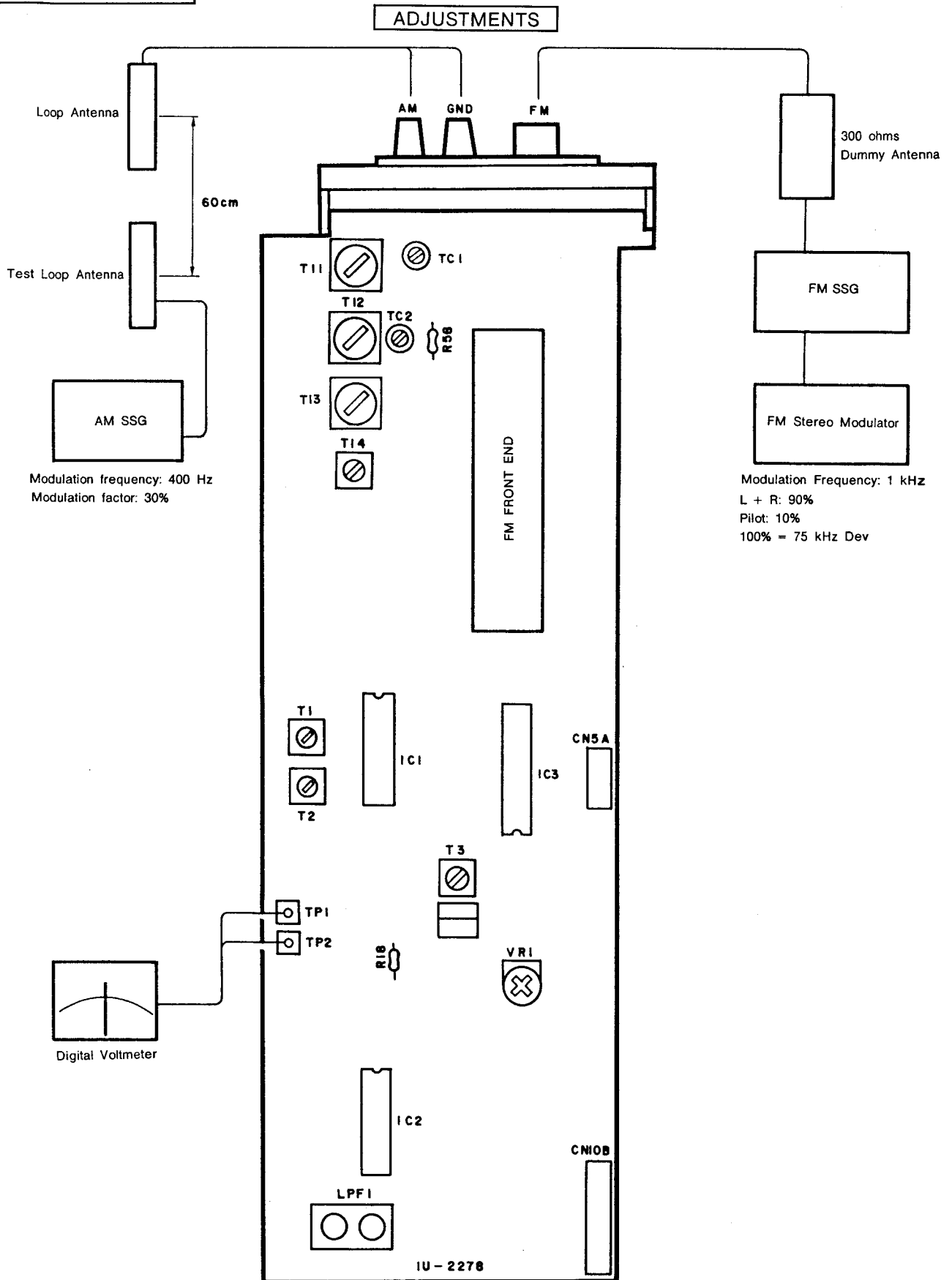

RECEIVER SECTION

1U-2278 B or C TUNER UNIT ASS'Y (Component Side)

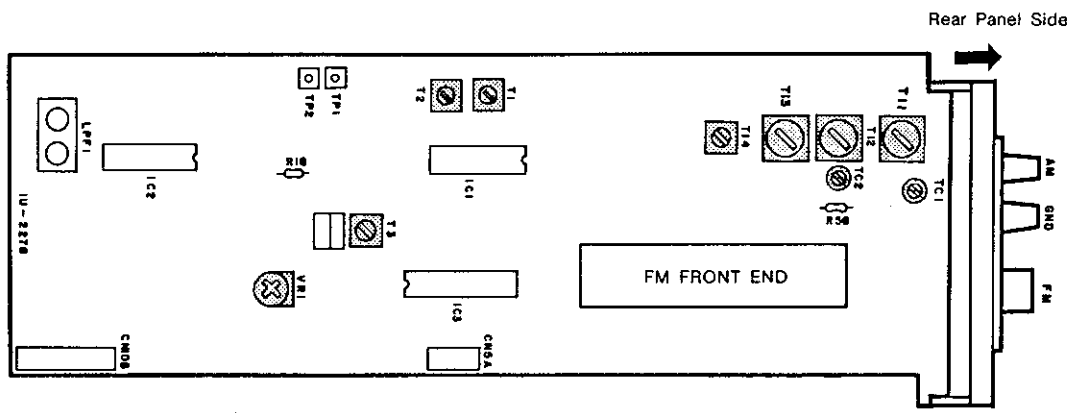

1. FM adjustment (BAND SELECTOR button: FM, STEREO / MONO MUTE button: AUTO)

Step	Adjustment item	Tuning point (Channel setting)	Input				Output		Adjustment location	Setting value	Notes	
			Measuring instrument	Frequency	Input level	Modulation	Connection location	Measuring instrument				Connection location
1	FM DC balance	98.00MHz	FM S.G.	98.00MHz	60dB μ	1kHz 75kHz DEV	FM antenna terminal	Digital Volt meter	TP.1, TP.2	T-1	0 \pm 50 mV	Perform with monaural modulation signal
2	Distortion	∅	∅	∅	∅	∅	∅	Distortion factor meter	Output jack	T-2	Minimum distortion	∅
3	Repeat Steps 1 and 2.											
4	AUTO STOP level	98.00MHz	FM S.G.	98.00MHz	22dB μ	1kHz 75kHz DEV	FM antenna terminal	Check for the lighting of TUNED	Output jack	VR-1	Input level 22dB μ \pm 4dB	(Level at which TUNED lights up) Level at which the output is provided

2. MW adjustment (BAND SELECT button: MW)

1	IF	Clear frequency (without a broadcast)	AM IF sweep	-	Level at which AGC is not applied	-	AM antenna terminal	Oscilloscope	⊕ TP.3 ⊖ TP.4	T-5	Waveform maximum and symmetry	
2	Band edge	522kHz	-	-	-	-	-	Digital voltmeter	⊕ TP.5 ⊖ TP.6	T-4	1.2V	
		1611kHz	-	-	-	-	-	-	-	-	Approx. 8.0V	No place to adjust
3	Tracking	603kHz	AM S.G.	603kHz	Level at which AGC is not applied	400Hz 30%	Loop antenna	VTVM	Output terminal	T-3	Maximum output	
4	Tracking	1404kHz	∅	1404kHz	∅	∅	∅	∅	∅	TC-1	Maximum output	
5	Repeat Steps 3 and 4, and set the output to maximum.											

3. LW adjustment (BAND SELECT button: LW)

1	Band edge	153kHz	-	-	-	-	-	Digital voltmeter	⊕ TP.5 ⊖ TP.6	T-7	1.2V	
		279kHz	-	-	-	-	-	-	-	-	Approx. 7.0V	No place to adjust
2	Tracking	163kHz	AM S.G.	163kHz	Level at which AGC is not applied	400Hz 30%	Loop antenna	VTVM	Output terminal	T-6	Maximum output	
3	Tracking	270kHz	∅	270kHz	∅	∅	∅	∅	∅	TC-2	Maximum output	
4	Repeat Steps 2 and 3, and set the output to maximum.											

Front End Part No.: 2160079005

No.	Name	No.	Name
1	ANT	5	Vt
2	ANT	6	+B
3	AGC	7	IF OUT
4	GND	8	OSC OUT

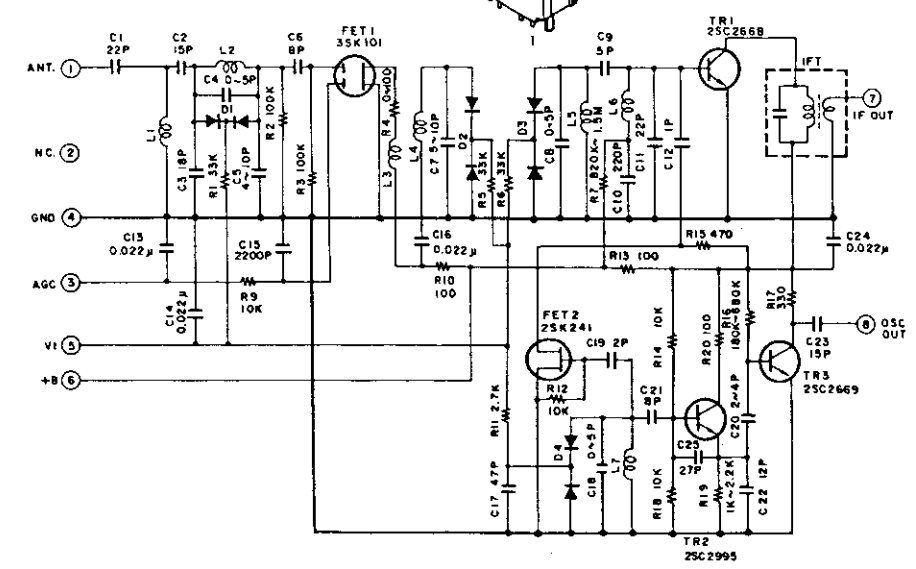
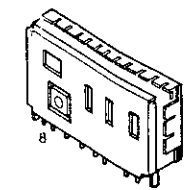

RECEIVER SECTION

IC's

LM7000 (IC003)

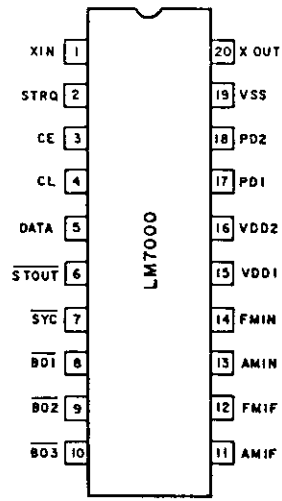
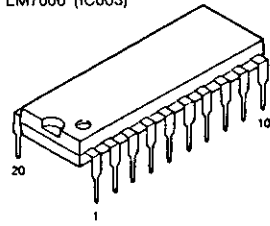

Pin Description
 SYNC : Clock (400 kHz) for the controller
 XIN, XOUT : X'tal oscillator (7.2 MHz) with built-in feedback resistor
 FM IN, AM IN : Local oscillator signal input
 CE, CL, DATA : Data input
 B01, B02, B03 : Band data output. B01 can be set as the time base output (8 Hz).
 STRQ : IF counter request input
 STOUT : Auto research stop signal output
 VDD1, VDD2, VSS : Power supply (VDD2 is a back-up power supply)
 AMIF, FMIF : IF signal input
 PD1, PD2 : Charge pump output

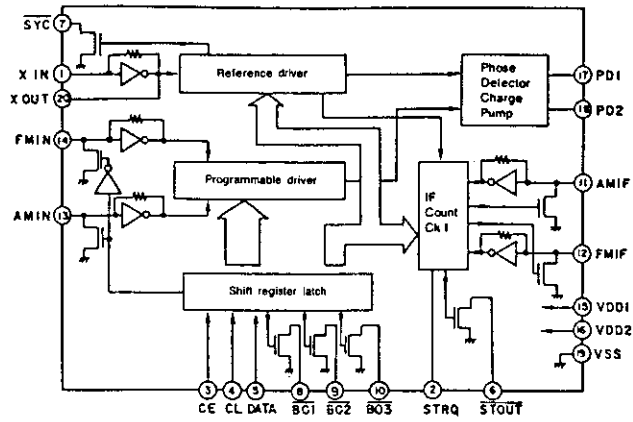

LA1267 (IC001)

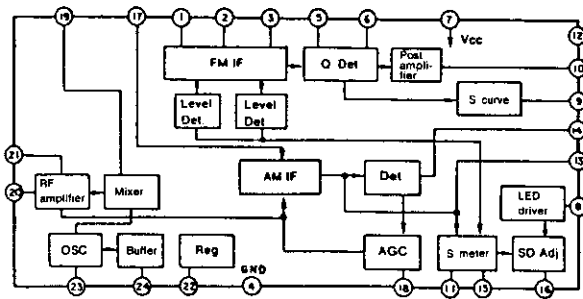
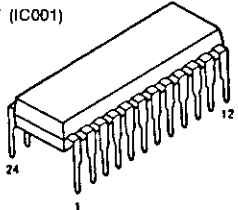

NJM78M06FA (IC118)

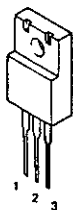

1: Input
 2: GND
 3: Output

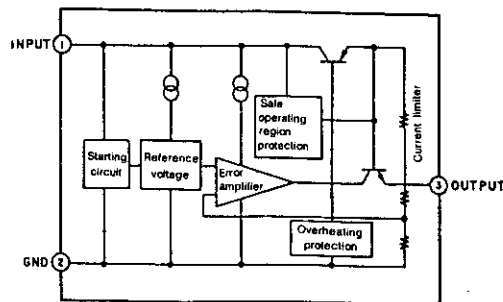

SEMICONDUCTORS

LA3410 (IC002)

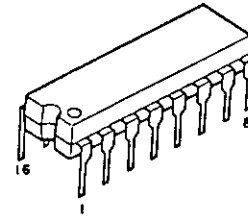

LC7582 (IC119)

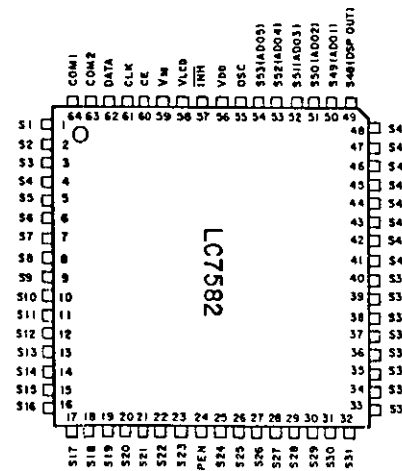
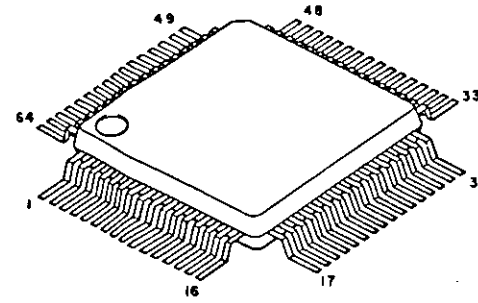

Pin Description

- S1 through S43 : Segment output pins
- S46 (DSP1), S44 (DSP2) : Segment output or DSP input pins
- S47 (AD1), S45 (AD2) : Segment output or AD input pins
- S48 (DSPOUT) : Segment output of DSP output pin
- S49 through S53 (AD01 through 5) : Segment output or AD output pins
- COM1, 2 : Common output pins (Only COM1 is used at time of 1:1 duty, and COM2 is set open)
- V_{CD} : LCD bias voltage setting pin
- OSC : Oscillation pin
- CE, CLK, DATA : Input pin for serial data transfer
- V_{SS}, V_{DD} : Supply pins
- INH : Display-off input pin. (Valid only with the output driver. This means that the transfer of serial data is possible while the display is off.)
- OPEN : No connection is made.

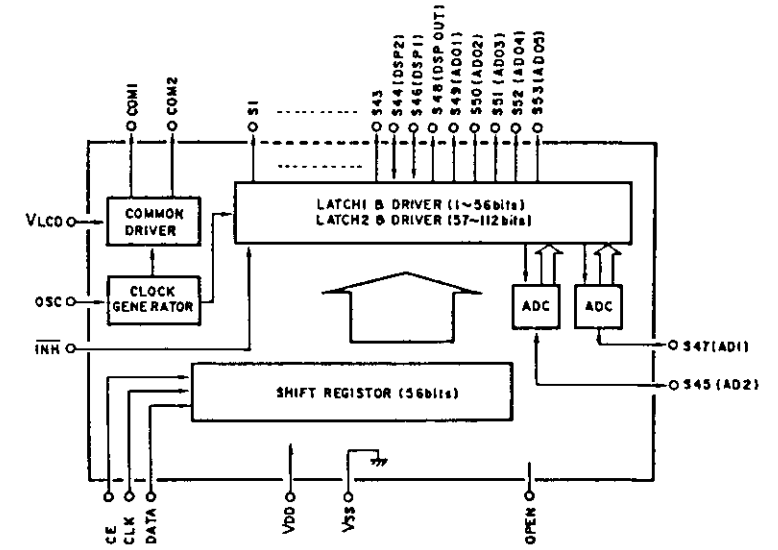
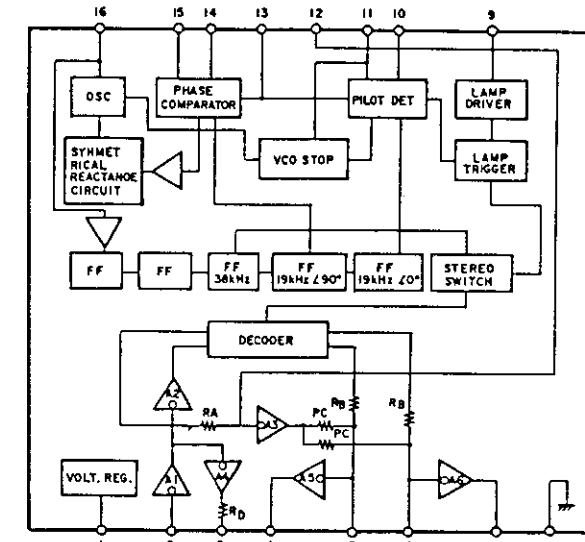

RECEIVER SECTION

LB1639 (IC110)

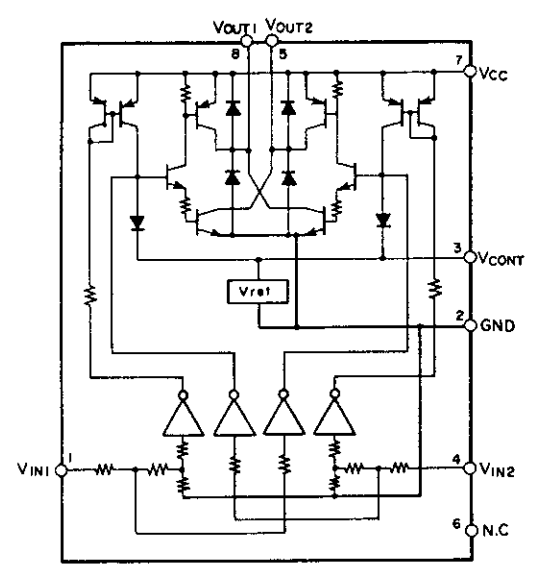
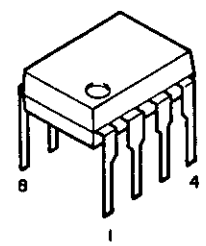

NJM2068DDC (IC107~109, 120)
NJM4558DD (IC105)

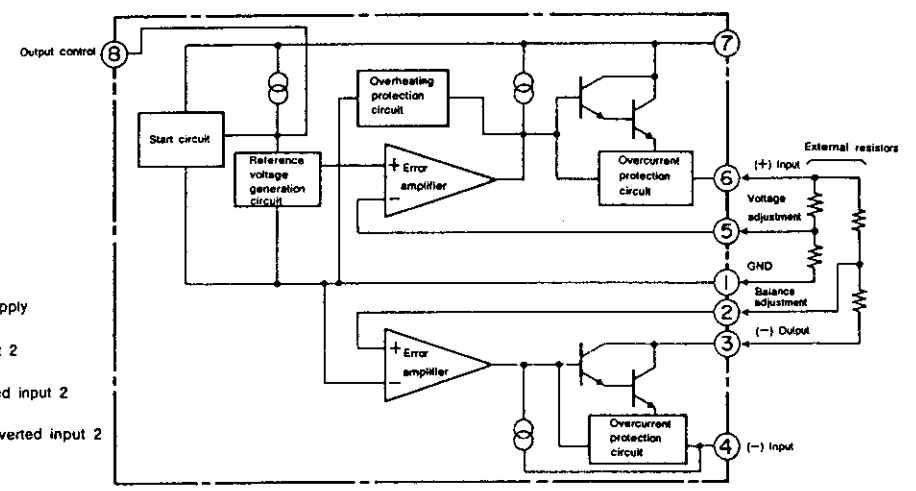
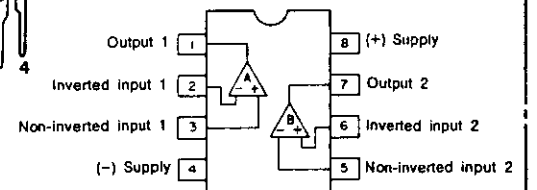
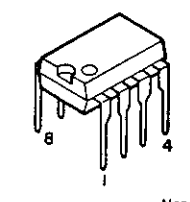

M5230L (IC114)

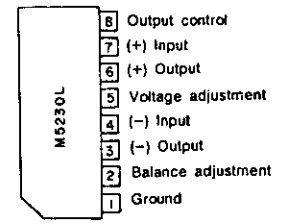
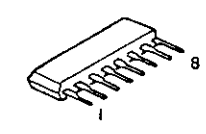

HD14051BP (IC101, 103)

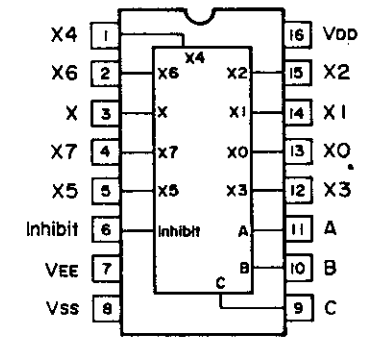
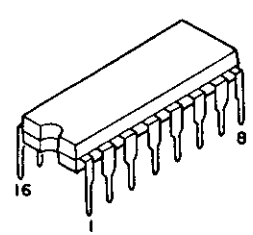

LC4966 (IC102)

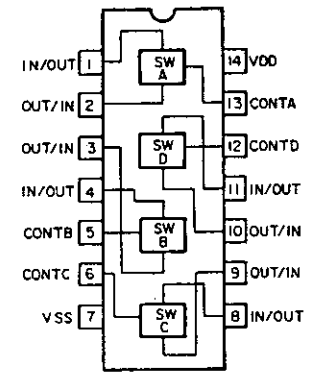
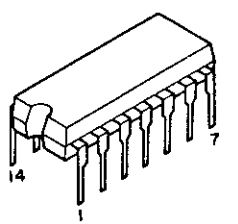

STK4152II (IC113)

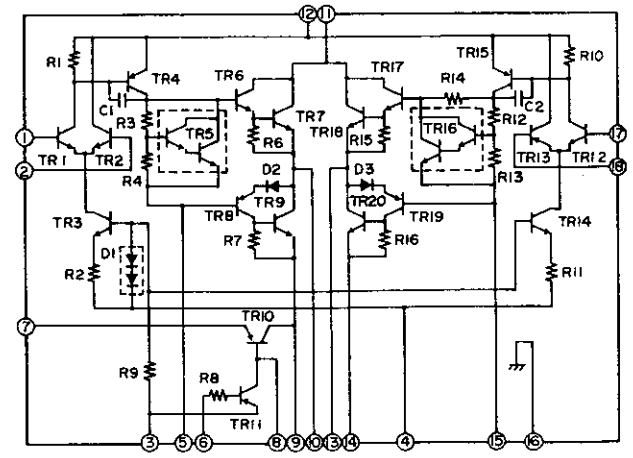
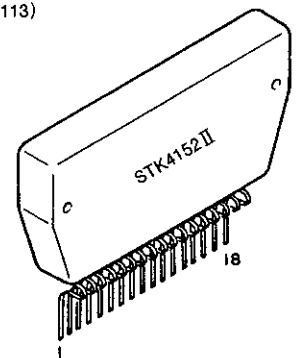

Transistors

2SC461 (C)
2SC2878 (A/B)

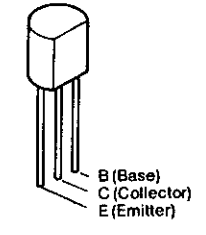

DTA114ES } PNP Type
DTA124ES }
DTA144ES }
DTC114ES } NPN Type
DTC144ES }

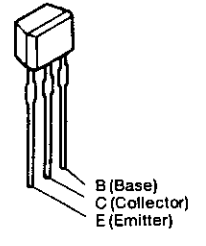

2SC2458 (BL)
2SA1048 (GR)

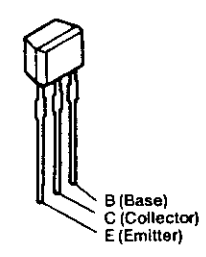

(FET)
2SK365 (BL/RG)

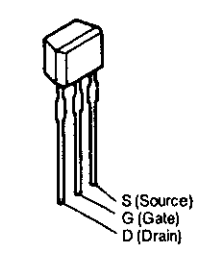

2SA1488 (Y/GR)
2SC3851 (Y/GR)

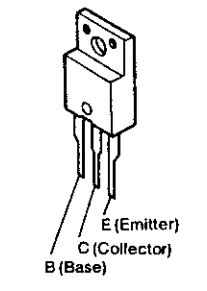

(FET)
2SK161 (GR)

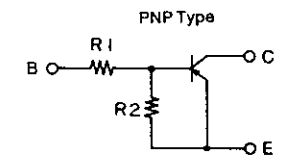
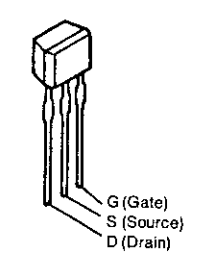

	R1	R2
DTA114ES	10k ohm	10k ohm
DTA124ES	22k ohm	22k ohm
DTA144ES	47k ohm	47k ohm

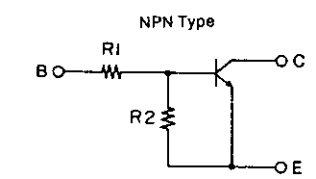

	R1	R2
DTC114ES	10k ohm	10k ohm
DTC144ES	47k ohm	47k ohm

(FET)
2SJ40 (D) / (E)

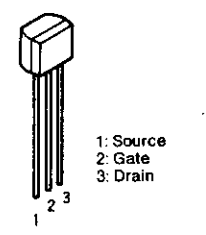

1: Source
2: Gate
3: Drain

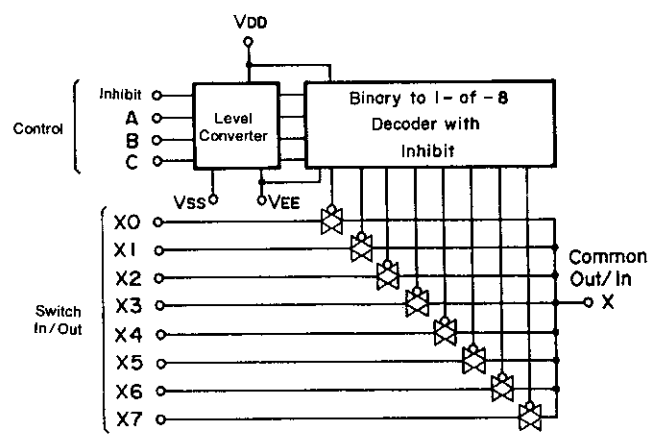

RECEIVER SECTION

● Diodes (including LED)



LED Ass'y
Part No.: 3939493002

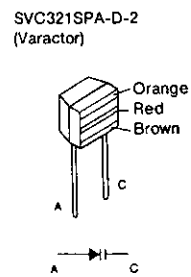
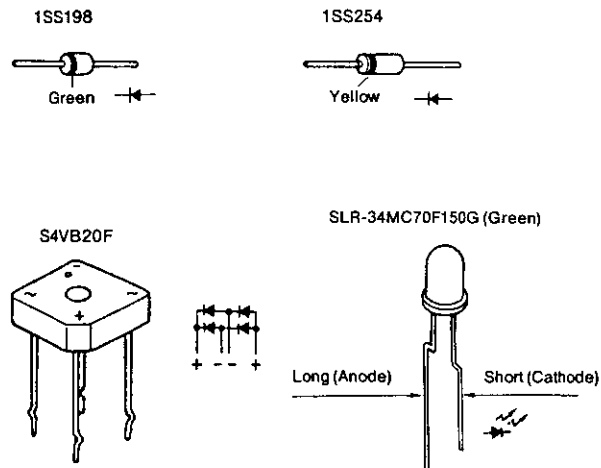
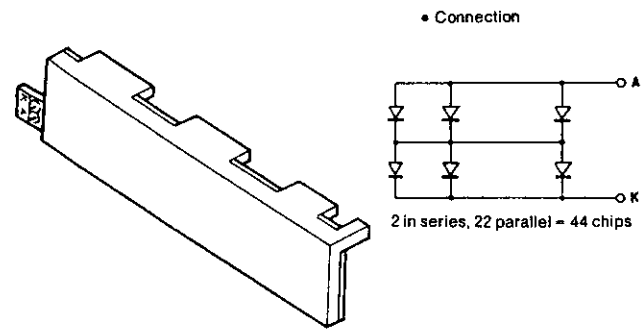

● Infrared Remote Control Sensor

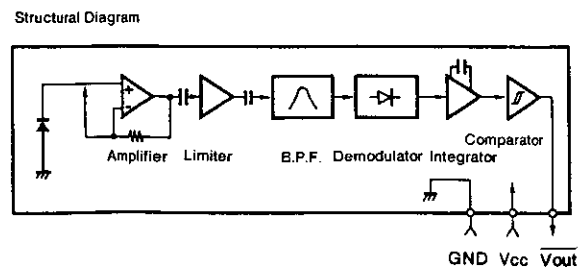
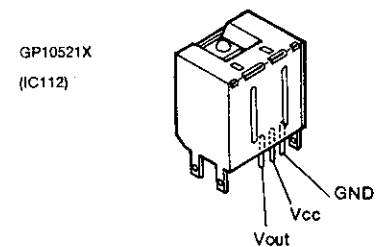

● LCD Ass'y
Part No.3934122006
(8189JP)

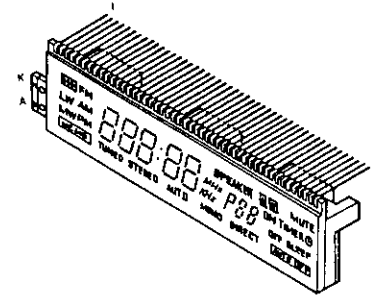

Segment division

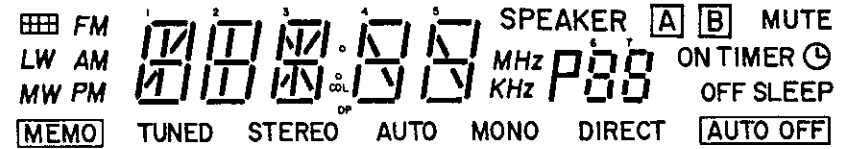

● LCD Pin Configuration Pin configuration definitions (segment side)

A/B	COM1	COM2	A/B	COM1	COM2
S 1	A11	A 4	S31	C (LW)	K (MONO)
S 2	A10	A 3	S32	M (KHz)	N (MHz)
S 3	A 9	A 2	S33	A (□□)	L (DIRECT)
S 4	A 8	A 1	S34	G 4	G 3
S 5	A 7	A 6	S35	T (P)	O (SPEAKER)
S 6	A 5	B 3	S36	G 2	G 1
S 7	B 8	B 2	S37	G 7	G 6
S 8	B 7	B 1	S38	G 5	H 3
S 9	B 5	B 6	S39	Q (B)	P (A)
S10	B 9	B 4	S40	H 7	H 2
S11	C12	C 4	S41	H 6	H 1
S12	C11	C 3	S42	S (OFF)	R (ON)
S13	C 9	C 2	S43	H 4	H 5
S14	C 8	C 1	S44	V (TIMER)	U (MUTE)
S15	C 7	C 6	S45	W (□)	X (SLEEP)
S16	C13	C10	S46	B (FM)	Y (AUTO OFF)
S17	D 2	C 5	S47	-	-
S18	I (STEREO)	D 1	S48	-	-
S19	E 4	E 3	S49	-	-
S20	E 7	E 2	S50	-	-
S21	E 6	E 1	S51	-	-
S22	E 9	E 8	S52	-	-
S23	E 5	F 3	S53	-	-
S24	F 7	F 2	H Common side		
S25	F 6	F 1	COM1		
S26	F 4	F 8	COM2		
S27	F 9	F 5			
S28	G (MEMO)	H (TUNED)			
S29	F (PM)	J (AUTO)			
S30	D (AM)	E (MW)			

Pin Connection

NO	1	2	3	4	5	6	7	8	9	10	11	12	13	14	15	16	17	18	19	20	21	22	23	24
NO	-	COM	1l	1m	1g	1i	1j	1c	2g	2i	2c	2l	3l	3m	3h	3i	3j	3k	DP	STEREO	4d	4h	4b	4k
COM1	COM	-	1d	1e	1f	1a	1b	2e	2f	2a	2b	2d	3d	3e	3f	3a	3b	3g	3c	COL	4e	4f	4a	4g
NO	25	26	27	28	29	30	31	32	33	34	35	36	37	38	39	40	41	42	43	44	45	46	47	48
COM1	4c	5h	5b	5d	5k	MEMO	PM	AM	LW	KHz		6d	P	6f	6g	6c	□	7g	7b	OFF	7d	TIMER		FM
COM2	5e	5f	5a	5g	5c	TUNED	AUTO	MW	MONO	MHz	DIRECT	6e	SPEAKER	6a	6b	7e	□	7i	7a	ON	7c	MUTE	SLEEP	AUTO OFF

MICROPROCESSOR DOCUMENTATION

HD404729B20FS: 2621484003

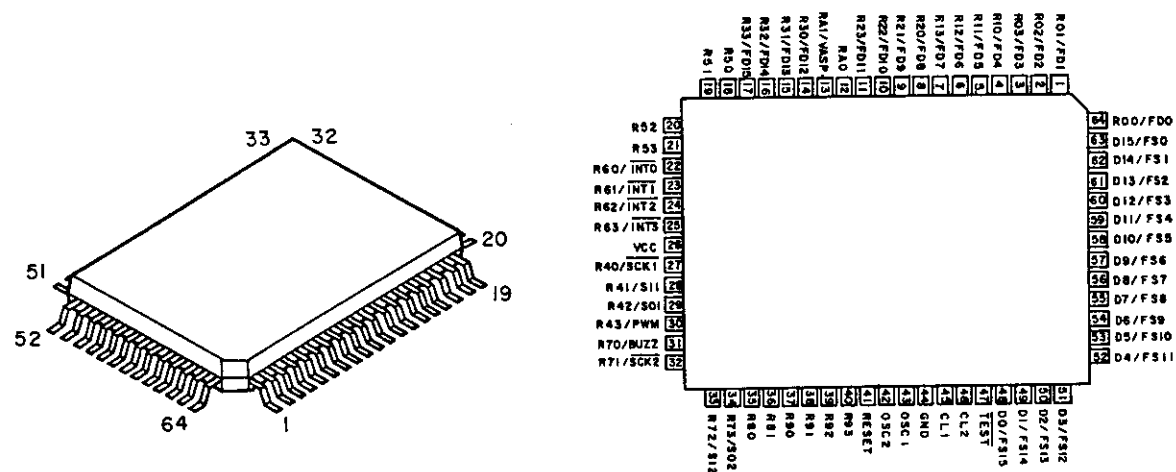

1. Overview

The functions of this microcomputer are made up of the following three pillars.

a. Tuner functions

These functions perform the required control for the reception of FM and AM broadcasts.

b. Auto Functions

Positioned at the heart of the system stereo, the auto functions perform serial communications with other components (such as the deck, CD, and amplifier) to provide overall control.

These functions decode the signals from the remote control and send them to each component of the system.

c. Timer functions

Counts the clock.

Operates the two kinds of timers: Every Day, and Sleep.

Note 1: When buttons 1 and 7 of the wiring diagram are pressed simultaneously and the power cord is inserted into the power outlet, the frequencies used for the tracking adjustment will automatically be registered in the preset memory as indicated below.

Use this information for tuning and other procedures.

	P1	P2	P3	P4	P5	P6	P7	P8	P9	P10
FM (MHz)	87.50	89.00	98.00	100.10	108.00	87.50	87.50	87.50	87.50	87.50
	P11	P12	P13	P14	P15	P16	P17	P18	P19	P20
MW (kHz)	522	603	846	999	1,098	1,404	1,512	1,611	522	522
	P21	P22	P23	P24	P25	P26	P27	P28	P29	P30
LW (kHz)	153	173	254	279	163	216	270	153	153	153

2. Receiving Band Table

Band	Receiving frequency	Local oscillator frequency	IF frequency	Frequency division ratio	Comparison frequency	Step frequency	Other
FM	87.50~108.00 MHz	98.2~118.9 MHz	10.7 MHz	1/2	25 kHz	50 kHz	STEREO
MW	522~1611 kHz	972~2061 kHz	450 kHz	—	9 kHz	9 kHz	
LW	153~279 kHz	603~729 kHz	450 kHz	—	1 kHz	1 kHz	

3. Description of Key and Selection Switch Inputs

No.	Function name	Function
1	P1-P10	Input keys for preset station calling and preset storage. P1 through P10 provide a numerical key pad function when making a time setting. The P10 key operates as a zero.
2	P+10	Specifies 10 stations to be added to the stored stations when making preset station calls and preset storage.
4	BAND	Operates in a cyclic manner to specify switching to the FM or MW or LW receiving modes.
7	FREQ, UP	*In the tuner mode Changes the receiving frequency upward one step at a time. When held for 0.5 seconds or longer, the change is continuous. The unit enters the auto tuning mode the moment the key is released. Pressing the key again engages the step operation. *In the clock mode Becomes the lower digits shift key of the display. (→)
8	FREQ, DOWN	*In the tuner mode Changes the receiving frequency downward one step at a time. When held for 0.5 seconds or longer, the change is continuous. The unit enters the auto tuning mode the moment the key is released. Pressing the key again engages the step operation. *In the clock mode Becomes the upper digits shift key of the display. (←)
10	MODE	At the time of FM reception, specifies the switching of the receiving mode between the stereo / mono auto mode and the forced mono mode.
14	CLEAR	Orders the clearing of the timer setting contents.
15	CLOCK ADJ	Orders a switch to the time setting mode. Operates as the ENT key for the time setting in the time setting mode. At this time the P1 through P10 keys operate as a numerical key pad, but the P+10 key is not accepted. *To escape from this mode part way through a time setting, press the CLEAR key.
16	ONCE	Provides a transition to the setting mode which operates the timer only once each day at the set time.
17	SLEEP	Provides a transition to the mode which switches the power off after a set time within 60 minutes. (On remote control)
18	POWER	Provides a toggle operation of RELAY OUT (H and L) which switches the power of other components of the system on and off.
19	STAND BY	Pressing this key selects whether or not the timer operation is performed. To engage the timer operation, use this key to light the stand by mark on the LCD.
21	TIMER START	Press this key to select the component of the system from which the start operation is to begin when the once timer is switched on. *The function selected by this key is stored. When the power is switched on at the timer setting time, the start code of the component is output.
22	FUNC	TUNER → TEPE → CD → PHONO → DAT
26	DISPLY	Switches between the clock display and the frequency display.
27	MEMORY	*In the tuner mode Provides a transition to the mode which registers the stations being received to preset memory. The "MEMORY" display will flash. Registration is accomplished by pressing the P1 through P10 keys and the P+10 key.

RECEIVER SECTION

MICROPROCESSOR PERIPHERAL WIRING DIAGRAM

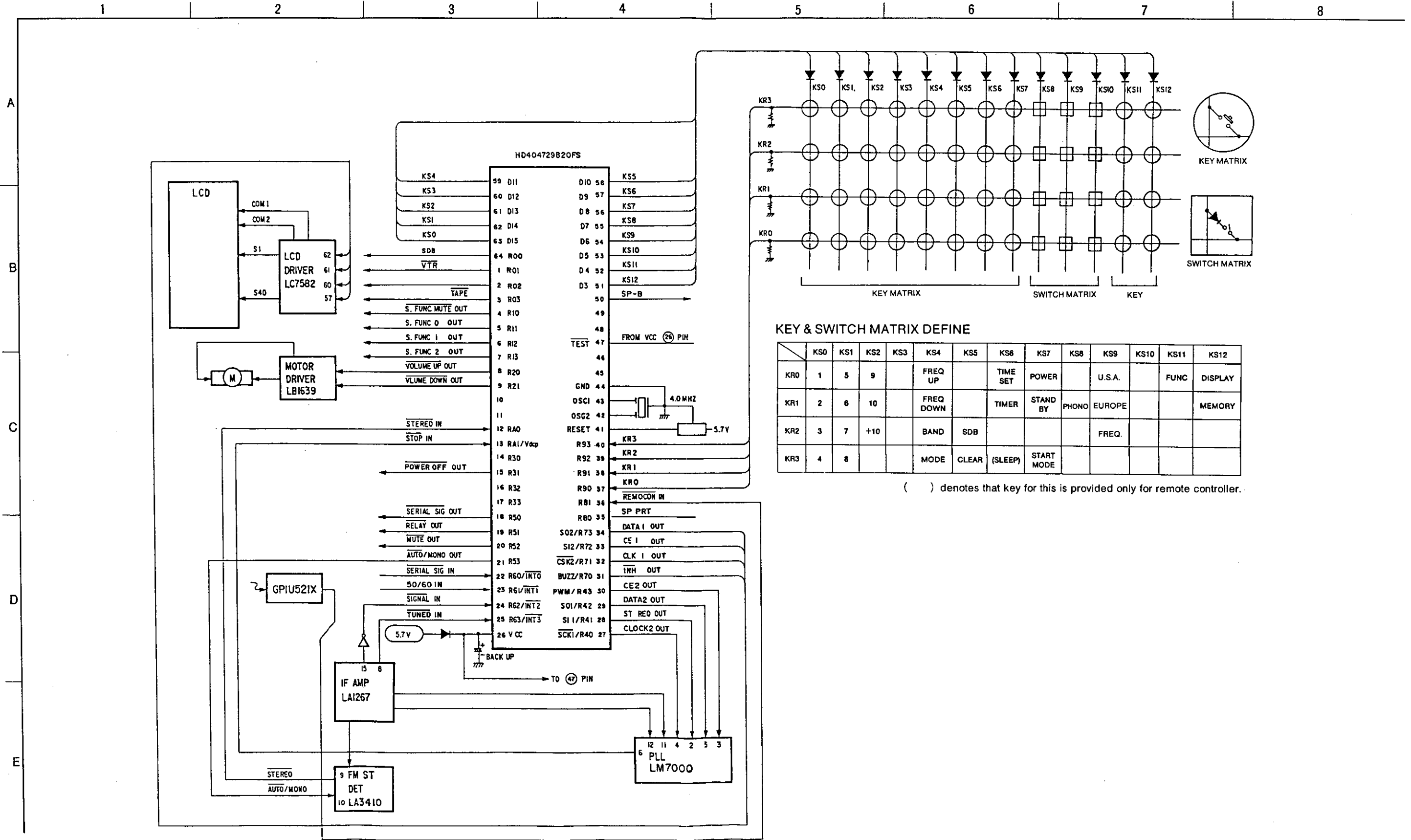

KEY & SWITCH MATRIX DEFINE

	KS0	KS1	KS2	KS3	KS4	KS5	KS6	KS7	KS8	KS9	KS10	KS11	KS12
KR0	1	5	9		FREQ UP		TIME SET	POWER		U.S.A.		FUNC	DISPLAY
KR1	2	6	10		FREQ DOWN		TIMER	STAND BY	PHONO	EUROPE			MEMORY
KR2	3	7	+10		BAND	SDB				FREQ.			
KR3	4	8			MODE	CLEAR (SLEEP)	START MODE						

() denotes that key for this is provided only for remote controller.

RECEIVER SECTION

4. IC HD404729B20FS Pin Description (See the Peripheral Wiring Diagram of Page 20.)

PIN NO.	Port Name	Function Name	Function
1	R02	VTR	Control signal output pin when the function has been set to DAT.
3	R03	TAPE	Control signal output pin when the function has been set to DAT.
4	R10	S.FUNC MUTE OUT	Outputs the muting output when there is a change of the S. FUNCO-2 OUT pin output.
5	R11	S.FUNC 0 OUT	Output pin for selecting the function.
6	R12	S.FUNC 1 OUT	Output pin for selecting the function.
7	R13	S.FUNC 2 OUT	Output pin for selecting the function.
8	R20	VOLUME UP OUT	Output pin used for the motor drive volume control. Up = low level
9	R21	VOLUME DOWN OUT	Output pin used for the motor drive volume control. Down = low level
12	RA0	STEREO IN	Input signal for taking in the stereo display signal from the FM MPX IC and displaying it on the LCD.
13	RA1	STOP IN	Input pin which takes in the signal that is output from the programmable divider when a station is tuned during auto tuning (i.e., when the IF count reaches the specified value).
15	R31	POWER OFF OUT	Control output pin used when the power is switched on and off. Power on = low level Power off = high level
18	R50	SERIAL SIG OUT	Output pin for sending serial signals. TXD
19	R51	RELAY OUT	This output pin is synchronized with the POWER button and performs a toggle operation. It drives a relay for switching the power on and off to another piece of equipment.
20	R52	MUTE OUT	Control signal output pin for applying muting to the audio output of the tuner.
21	R53	AUTO/MONO OUT	This signal output pin is synchronized with the input of the MULTI MODE button at the time of FM reception and performs a toggle operation. It is used to control the monaural/stereo switching pin of the FM MPX IC.
22	R60/INT0	SERIAL SIG IN	Input pin for handling serial communications. RXD
23	R61/INT1	50/60 IN	50/60 Hz half wave rectification pulse input pin. (Half wave)
24	R62/INT2	SIGNAL IN	Input pin for detecting that a station is in the vicinity during auto tuning. Active low.
25	R63/INT3	TUNED IN	Pin for taking in the signal when the tuning circuit has been properly tuned. Low level when tuned.
26	Vcc		5V supply pin. (For back ups)
27	R40/SCK1	CLOCK 2 OUT	Clock output pin used for serial data when data is sent to the programmable divider.
28	R41/SI1	ST REQ OUT	Output pin for requesting that the IC count operation be started to the programmable divider when the signal of a local station has been input from the detection IC during auto tuning.
29	R42/SO1	DATA 2 OUT	Serial data output pin for sending data to the programmable divider of the PLL IC.
30	R43/PWN	CE 2 OUT	This (output) pin is set to high level when sending data to the programmable divider, and when finished, the pin is returned to low level and serves to latch the register.
31	R70/BUZZ	INH OUT	Output pin used for forcing off the display of the LCD driver. Low level = forced off High level = display

PIN NO.	Port Name	Function Name	Function
32	R71/SCK2	CLK 1 OUT	Clock output pin for serial data transmission, used for sending data to the LCD driver.
34	R73/SO2	DATA 1 OUT	Output pin used for sending data to the LCD driver.
36	R81	REMOCON IN	Input pin for the remote control.
37	R90	KR 0 IN	KEY RETURN pulse input pin.
38	R91	KR 1 IN	KEY RETURN pulse input pin.
39	R92	KR 2 IN	KEY RETURN pulse input pin.
40	R93	KR 3 IN	KEY RETURN pulse input pin.
41	RESET		System reset input pin for the microprocessor.
42	OSC 2		System clock input pin for the microprocessor.
43	OSC 1		System clock input pin for the microprocessor. (f = 4 MHz)
44	GND		Ground pin.
47	TEST		Connected to the Vcc (pin 26) pin.
51	D 3	KS12 OUT	KEY STROBE PULSE output pin.
52	D 4	KS11 OUT	KEY STROBE PULSE output pin.
53	D 5	KS10 OUT	KEY STROBE PULSE output pin.
54	D 6	KS 9 OUT	KEY STROBE PULSE output pin.
55	D 7	KS 8 OUT	KEY STROBE PULSE output pin.
56	D 8	KS 7 OUT	KEY STROBE PULSE output pin.
57	D 9	KS 6 OUT	KEY STROBE PULSE output pin.
58	R10	KS 5 OUT	KEY STROBE PULSE output pin.
59	D11/FS 4	KS 4 OUT	KEY STROBE PULSE output pin.
60	D12/FS 3	KS 3 OUT	KEY STROBE PULSE output pin.
61	D13/FS 2	KS 2 OUT	KEY STROBE PULSE output pin.
62	D14/FS 1	KS 1 OUT	KEY STROBE PULSE output pin.
63	D15/FS 0	KS 0 OUT	KEY STROBE PULSE output pin.
64	R00	SDB	Control output pin for switching SDB on and off. On = high level Off = low level

RECEIVER SECTION

PRINTED WIRING BOARD

1U-2277 MAIN UNIT ASS'Y

Component Side

1 2 3 4 5 6 7 8

A

B

C

D

E

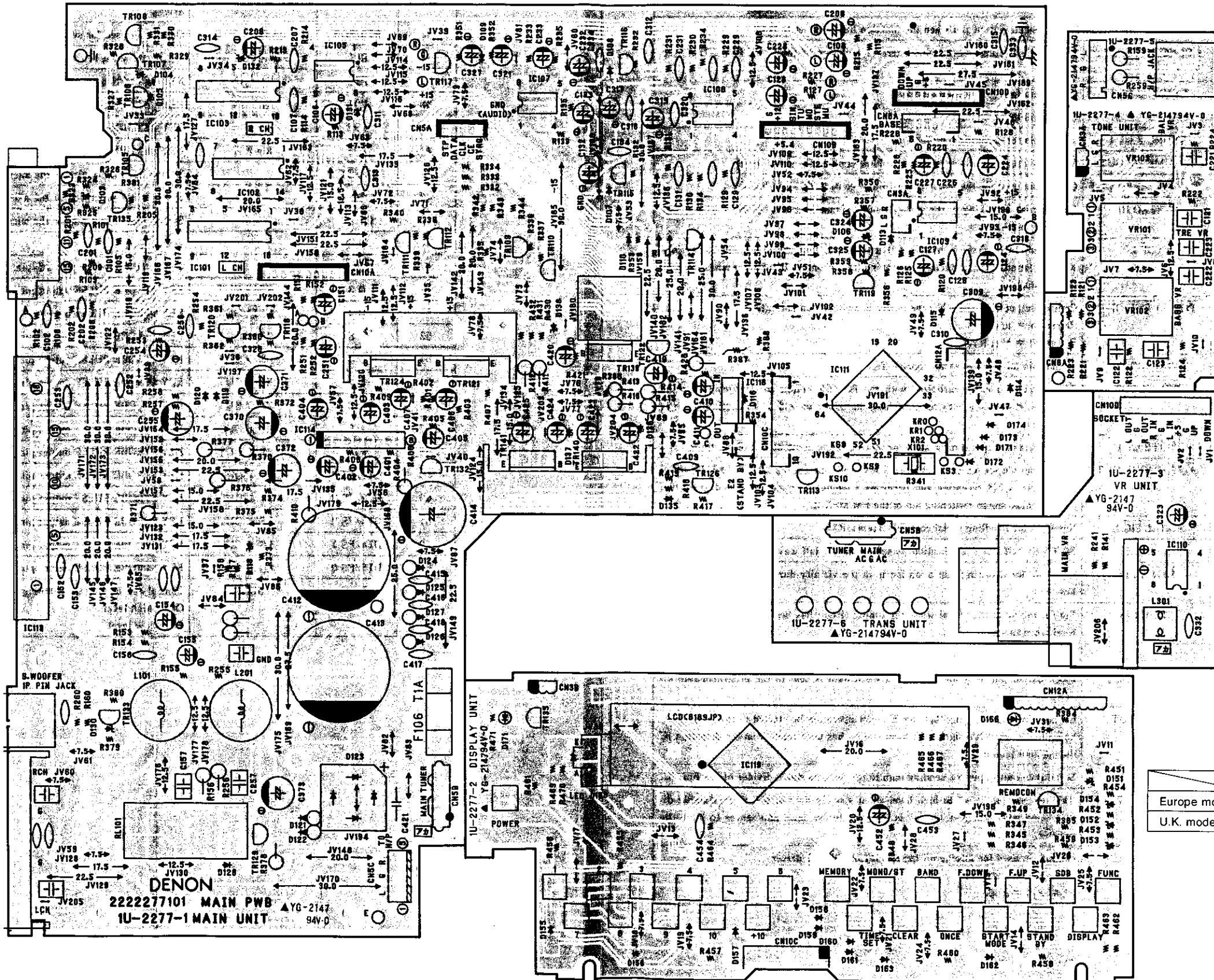

	Main Unit
Europe model	1U-2277B
U.K. model	1U-2277C

RECEIVER SECTION

1 2 3 4 5 6 7 8

Pattern Side

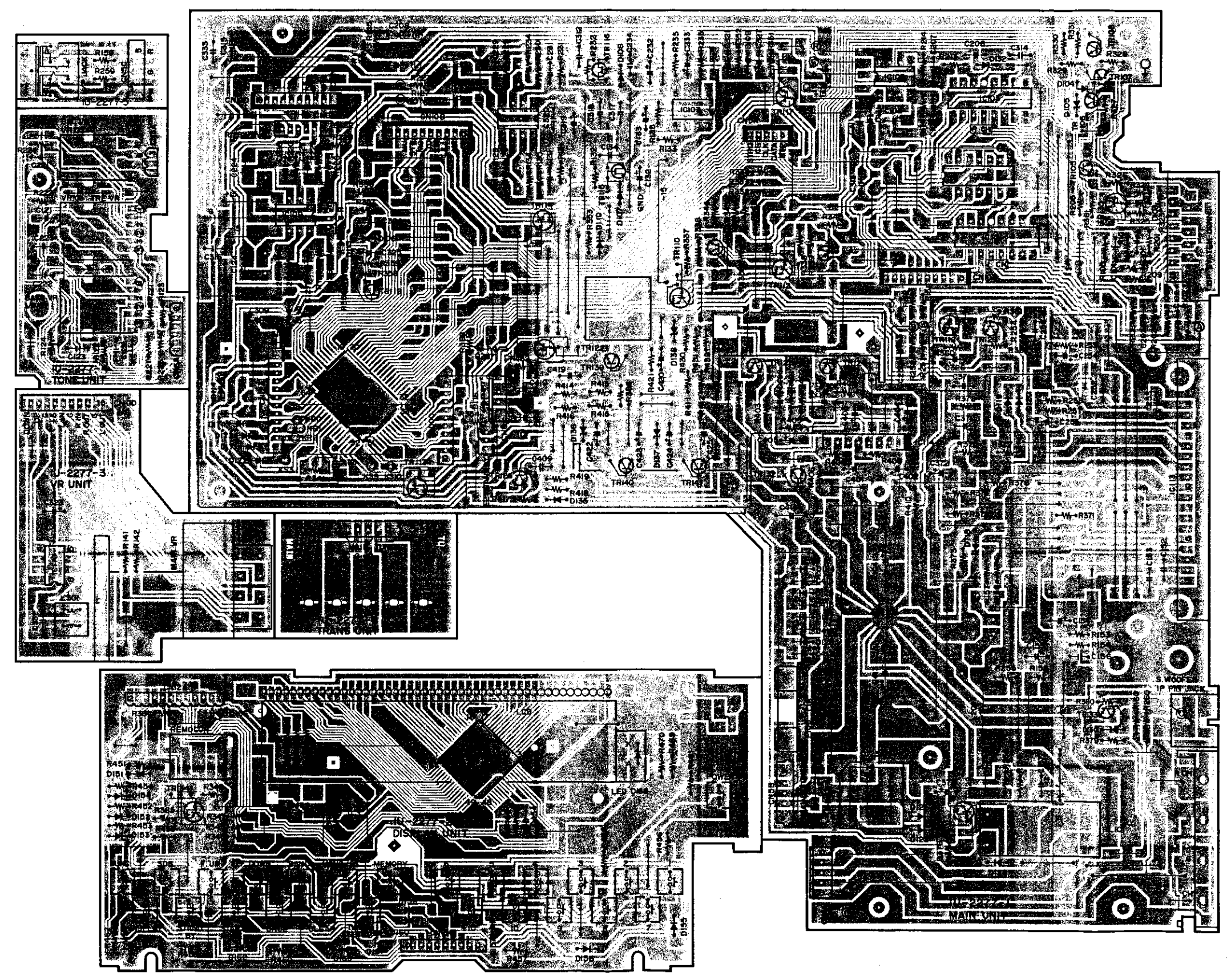

A
B
C
D
E

RECEIVER SECTION

1

2

3

4

5

6

7

8

1U-2278 TUNER UNIT ASS'Y

Component Side

	Tuner Unit
Europe model	1U-2278B
U.K. model	1U-2278C

A

B

C

D

E

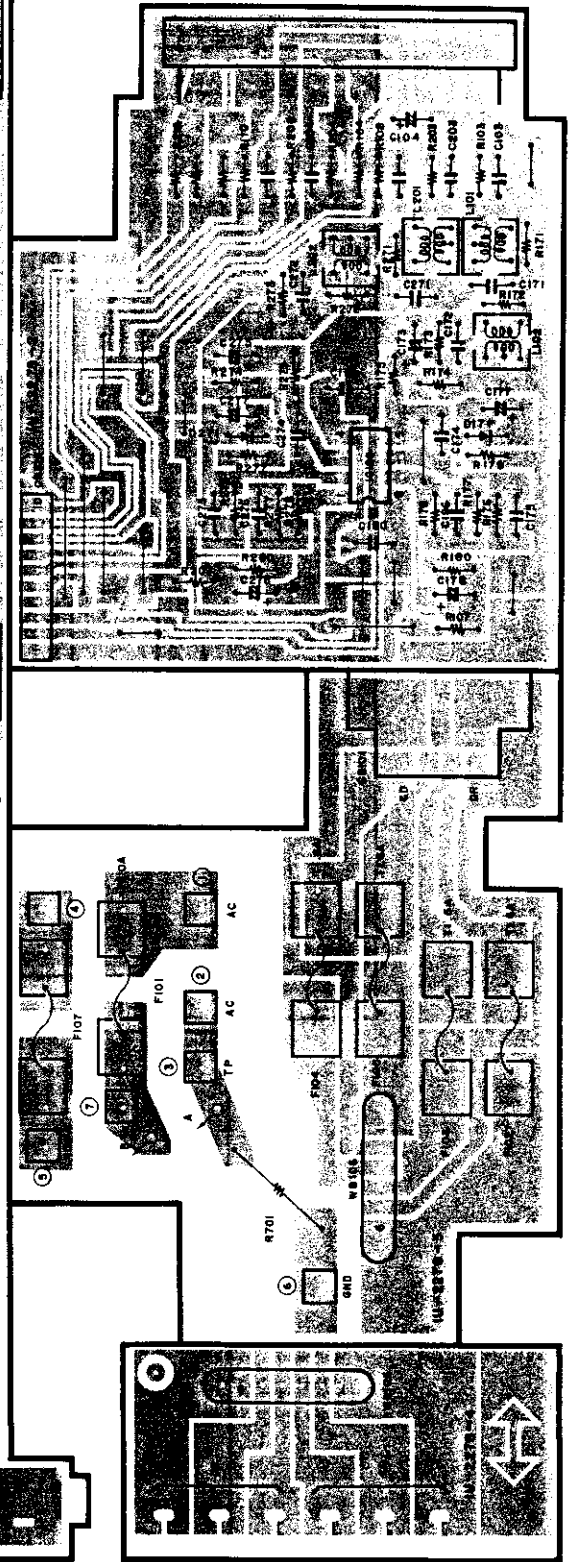
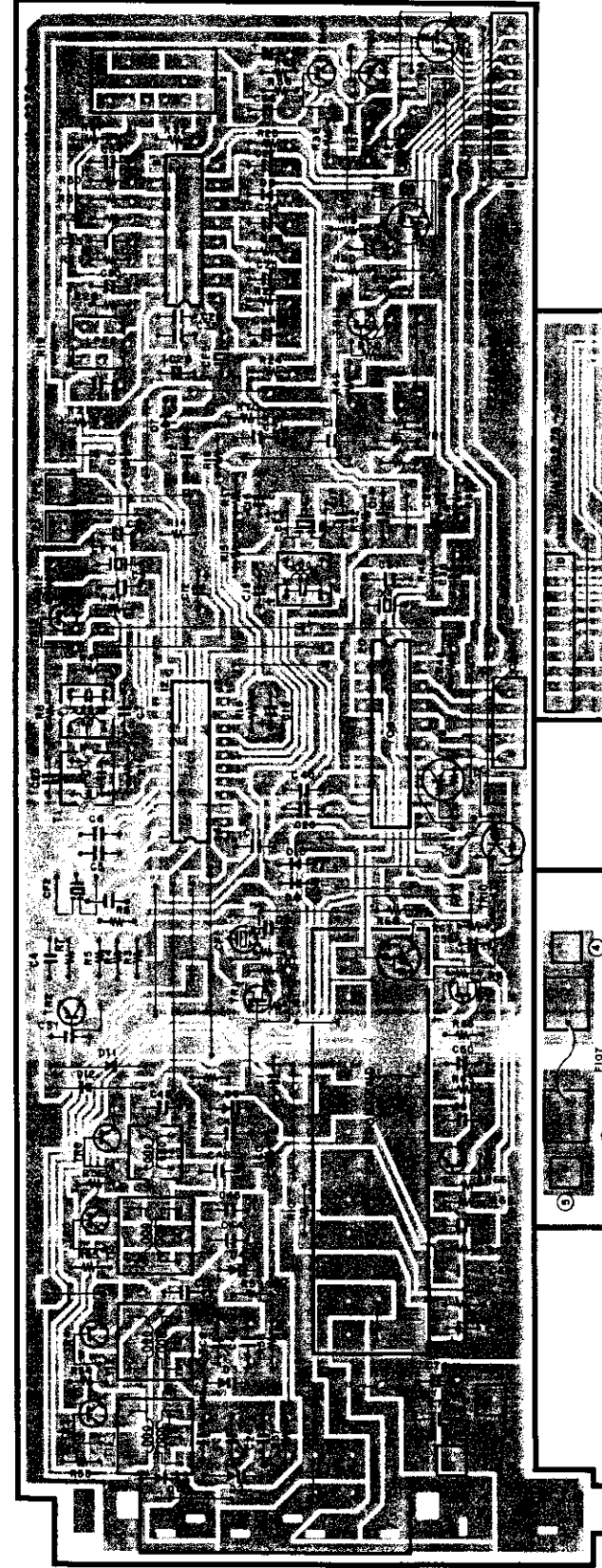
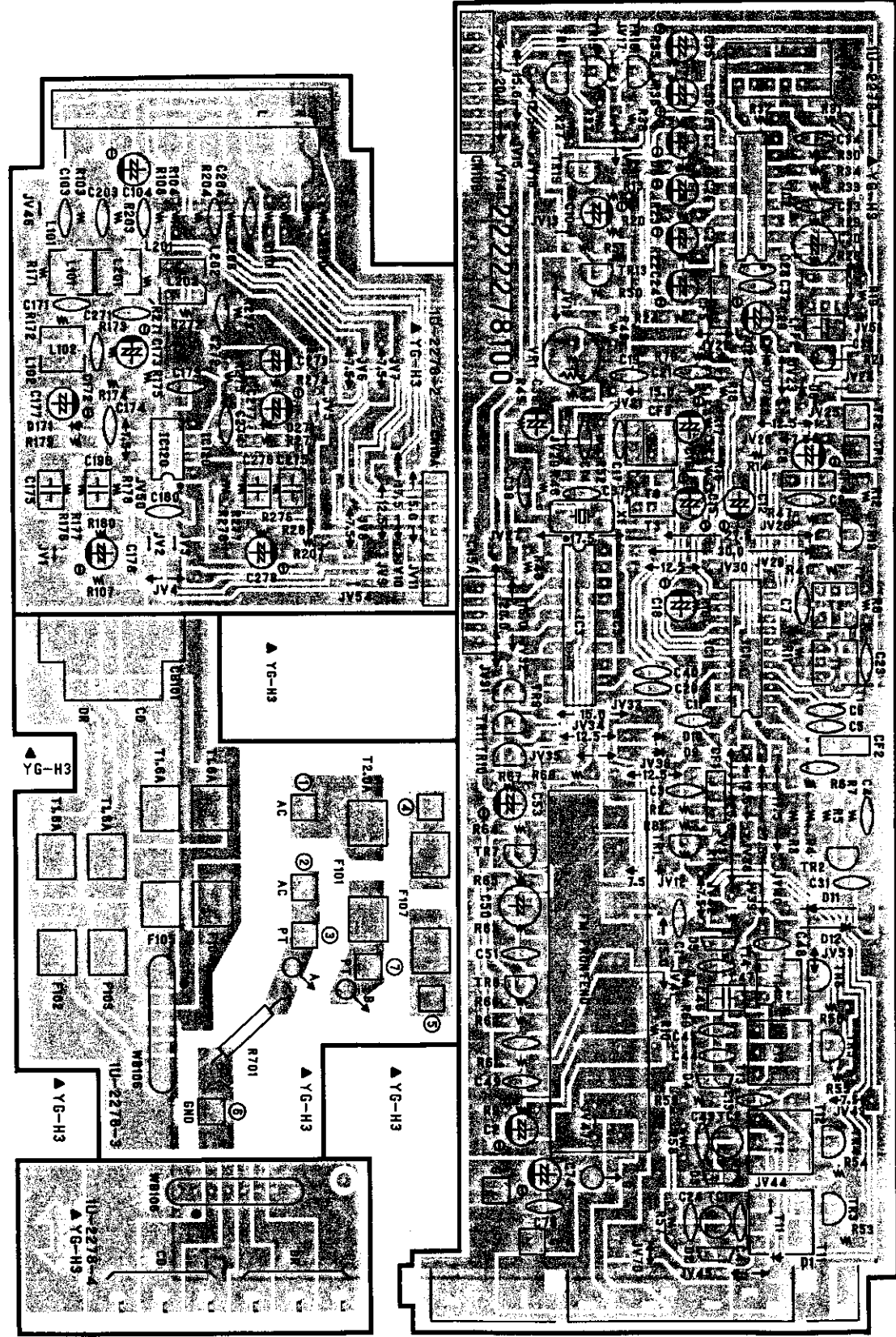

RECEIVER SECTION

NOTE FOR PARTS LIST

- Part indicated with the mark "◎" are not always in stock and possibly to take a long period of time for supplying, or in some case supplying of part may be refused.
- When ordering of part, clearly indicate "1" and "I" (i) to avoid mis-supplying.
- Ordering part without stating its part number can not be supplied.
- Part indicated with the mark "★" is not illustrated in the exploded view.
- Not including Carbon Film ±5%, 1/4 W Type in the P. W. Board parts list. (Refer to the Schematic Diagram for those parts.)

• Resistors

Ex.: RN 14K 2E 182 G FR
 Type Shape and performance Power Resistance Allowable error Others

RD : Carbon	2B : 1/8W	F : ±1%	P : Pulse-resistant type
RC : Fixed	2E : 1/4W	G : ±2%	NL : Low noise type
RS : Metallic film	2H : 1/2W	J : ±5%	NB : Non-burning type
RW : Winding	3A : 1W	K : ±10%	FR : Fuse resistor
RN : Metal film	3D : 2W	M : ±20%	F : Lead wire forming
RK : Metal mixture	3F : 3W		
	3H : 5W		

★ Resistance

1 8 2 ⇒ 1800 ohm = 1.8 kohm
 Indicates number of zeros after effective number
 2-digit effective number, decimal point indicated by R.
 • Units: ohm

• Capacitors

Ex.: CE 04W 1H 2R2 M BP
 Type Shape and performance Dielectric strength Capacity Allowable error Others

CE : Aluminum foil electrolyte	0J : 6.3V	F : ±1%	HS : High stability type
CA : Aluminum solid electrolyte	1A : 10V	G : ±2%	BP : Non-polar type
CS : Tantalum electrolyte	1C : 16V	J : ±5%	HR : Ripple-resistant type
CQ : Film	1E : 25V	K : ±10%	DL : For charge and discharge
CK : Ceramic	1V : 35V	M : ±20%	HF : For assuring high frequency
CC : Ceramic	1H : 50V	Z : +80%	U : UL part
CP : Oil	2A : 100V	-20%	C : CSA part
CM : Mica	2B : 125V	P : +100%	W : UL-CSA type
CF : Metallized	2C : 160V	-0%	F : Lead wire forming
CH : Metallized	2D : 200V	C : ±0.25pF	
	2E : 250V	D : ±0.5pF	
	2H : 500V	- : Others	
	2J : 630V		

★ Capacity

2 R 2 ⇒ 2.2 μF
 1-digit effective number, decimal point indicated by R.
 2-digit effective number, decimal point indicated by R.

- Units: μF, (for P, pF (μμF))
- When the dielectric strength is indicated in AC, "AC" is included after the dielectric strength value.

RECEIVER SECTION

1U-2277B MAIN UNIT PARTS LIST for Europe model

1U-2277C MAIN UNIT PARTS LIST for U.K. model

Ref. No.	Part No.	Part Name	Remarks	Ref. No.	Part No.	Part Name	Remarks
SEMICONDUCTORS GROUP				CAPACITORS GROUP			
IC101	262 0621 003	IC HD14051BP		△R404	241 2387 908	Carbon Film 1 ohm 1/4W (N.B)	RD14B2E010JNBS
IC102	263 0359 006	IC LC4966		△R410	241 2387 908	Carbon Film 1 ohm 1/4W (N.B)	RD14B2E010JNBS
IC103	262 0621 003	IC HD14051BP		△R412	244 2043 924	Metal Oxide Film 68 ohm, 1W	RS14B3A680JS (S)
IC105	265 0030 004	IC NJM4558D-D		△R413~416	244 2055 938	Metal Oxide Film 6.8 ohm, 1W	RS14B3A680JS (S)
IC107~109	263 0609 002	IC NJM2068DDC		△R428	244 2055 954	Metal Oxide Film 150 ohm, 1W	RS14B3A151JS (S)
IC110	263 0476 002	IC LB1639		△	244 0090 021	Metal Oxide Film 220 ohm, 2W	RS14B3D221JNBF
IC111	262 1484 100	IC HD404729B20FS	μ-Com	VR101,102	211 9103 003	Variable Resistor 50k ohm	Tone
IC112	499 0172 002	IC GP1U521X	Remocon Receiver	VR103	211 9105 001	Variable Resistor 50k ohm	Balance
IC113	265 0073 003	IC STK4152II		VR104	211 9067 000	Variable Resistor 100k ohm	Volume
IC114	263 0646 007	IC M5230L		CAPACITORS GROUP			
IC118	263 0586 002	IC NJM78M06FA	Regulator	C101,201, 102,202	253 4538 046	Ceramic 100pF/50V	CC45SL1H101J (DD-3)
IC119	263 0533 000	IC LC7852		C106	254 4195 013	Electrolytic 4.7 μF/35V	CE04W1V4R7M (SRA)
TR105~108	293 0317 906	Transistor 2SC2458 (BL)		C107,207	253 3631 009	Ceramic 150pF/50V	CC45SL1H151J
TR109	271 0191 906	Transistor 2SA1048 (GR)		C108,208	254 4254 006	Electrolytic 10 μF/16V	CE04W1C100M
TR110	269 0040 902	Transistor DTC144ES (47k-47k)	built in Resistor	C115,215	253 1179 008	Ceramic 330pF/50V	CK45B1M331K (DD-3)
TR111	271 0191 906	Transistor 2SA1048 (GR)		C121,221	255 1120 039	Film 0.0018 μF/50V	CQ93M1H182J
TR112	269 0040 902	Transistor DTC144ES (47k-47k)	built in Resistor	C122,123, 222,223	255 1121 067	Film 0.022 μF/50V	CQ93M1H223J
TR113	269 0020 906	Transistor DTC114ES (10k-10k)	built in Resistor	C124,224	254 4260 045	Electrolytic 1 μF/50V	CE04W1H010M
TR114	269 0093 904	Transistor DTA144ES (47k-47k)	built in Resistor	C126,226	253 1179 042	Ceramic 220pF/50V	CK45B1H221K (DD-3)
TR115,116	275 0067 906	FET 2SJ40 (D)/(E)		C127,227	254 4254 006	Electrolytic 10 μF/16V	CE04W1C100M
TR117	269 0063 905	Transistor DTA124ES (22k-22k)	built in Resistor	C128,228	254 4258 002	Electrolytic 4.7 μF/35V	CE04W1V4R7M
TR118	269 0020 906	Transistor DTC114ES (10k-10k)	built in Resistor	C129,229, 130,230	253 1179 068	Ceramic 330pF/50V	CK45B1H331K (DD-3)
TR119,120	273 0317 906	Transistor 2SC2458 (BL)		C131,231	253 1180 044	Ceramic 1500pF/50V	CK45B1H152K (DD-3)
TR121	271 0206 008	Transistor 2SA1488 (Y)/(G)		C132	254 4260 032	Electrolytic 0.47 μF/50V	CE04W1HR47M
TR122	269 0093 904	Transistor DTA144ES (47k-47k)	built in Resistor	C133	254 4196 025	Electrolytic 0.33 μF/50V	CE04W1HR33M (SRA)
TR124	273 0338 008	Transistor 2SC3851 (Y)/(G)		C134,234	253 1180 028	Ceramic 1000pF/50V	CK45B1H102K (DD-3)
TR126	273 0317 906	Transistor 2SC2458 (BL)		C141,241	254 4254 006	Electrolytic 10 μF/16V	CE04W1C100M
TR126	273 0338 008	Transistor 2SC3851 (Y)/(G)		C151,251	254 4254 006	Electrolytic 10 μF/16V	CE04W1C100M
TR129	269 0020 906	Transistor DTC114ES (10k-10k)	built in Resistor	C152,252	253 1179 068	Ceramic 330pF/50V	CK45B1H331K (DD-3)
TR132	273 0317 906	Transistor 2SC2458 (BL)		C153,253	253 1180 002	Ceramic 680pF/50V	CK45B1H681K (DD-3)
TR133	273 0253 918	Transistor 2SC2878 (A/B)		C154,254	254 4258 002	Electrolytic 4.7 μF/35V	CE04W1V4R7M
TR134~136	269 0020 906	Transistor DTC114ES (10k-10k)	built in Resistor	C155,255	254 4261 028	Electrolytic 100 μF/50V	CE04W1H010M
TR140,141	273 0338 008	Transistor 2SC3851 (Y)/(G)		C156,256	253 4537 063	Ceramic 47pF/50V	CC45SL1H470J (DD-3)
D103~105	276 0462 915	Zener Diode HZS6B-2	6V	C157,257	256 1034 034	Metalized 0.047 μF/50V	CF93A1H473J
D106	276 0452 925	Zener Diode HZS3A-3	3V	C158,258	253 1179 084	Ceramic 470pF/50V	CK45B1H471K (DD-3)
D107~110	276 0531 901	Diode 1SS254		C206	254 4258 002	Electrolytic 4.7 μF/35V	CE04W1V4R7M
D113~116	276 0432 903	Diode 1SS270A		C232	254 4196 038	Electrolytic 0.47 μF/50V	CE04W1HR47M (SRA)
D118	276 0455 919	Zener Diode HZS4A-2	4V	C233	254 4260 029	Electrolytic 0.33 μF/50V	CE04W1HR33M
D119,120	276 0503 900	Diode 1SS198		C309	254 4250 767	Electrolytic 1000 μF/6.3V	CE04W0J102M
D121,122	276 0550 908	Diode 1SR139-200		C310,311	254 1024 003	Ceramic 0.01 μF/50V	CK45F1H103Z
△D123	276 0338 007	Diode S4VB20F	Bridge	C312~314	253 9036 006	BC Ceramic 0.1 μF/25V	CK45-1E104Z
△D124~127	276 0550 908	Diode 1SR139-200		C317	254 4256 046	Electrolytic 100 μF/25V	CE04W1E101M
D128	276 0432 903	Diode 1SS270A		C318	253 9036 006	BC Ceramic 0.1 μF/25V	CK45-1E104Z
D130	276 0474 903	Zener Diode HZS12B-1	12V	C319	254 4256 046	Electrolytic 100 μF/25V	CE04W1E101M
D131,132	276 0465 925	Zener Diode HZS7B-3	7V	C320	253 9036 006	BC Ceramic 0.1 μF/25V	CK45-1E104Z
D135	276 0432 903	Diode 1SS270A		C321	254 4260 045	Electrolytic 1 μF/50V	CE04W1H010M
D136,137	276 0462 915	Zener Diode HZS6B-2	6V	C323	254 4252 037	Electrolytic 100 μF/10V	CE04W1A101M
D138	276 0474 903	Zener Diode HZS12B-1	12V	C324,325	254 4252 024	Electrolytic 47 μF/10V	CE04W1A470M
D151~154	276 0462 915	Zener Diode HZS6B-2	6V	C326	253 1024 003	Ceramic 0.01 μF/50V	CK45F1H103Z
D155~163	276 0432 903	Diode 1SS270A		C327	254 4260 082	Electrolytic 10 μF/50V	CE04W1H100M
D166	393 9492 906	LED SLR-34MC70F150	LED Green	C332,333	253 1042 003	Ceramic 0.01 μF/50V	CK45F1H103Z
D168	393 9493 002	LED Assy		C370,371	254 4261 028	Electrolytic 100 μF/50V	CE04W1H101M
D171	276 0432 903	Diode 1SS270A		C372	254 4260 087	Electrolytic 10 μF/50V	CE04W1H100M
D173	276 0432 903	Diode 1SS270A		C373	254 4260 090	Electrolytic 22 μF/50V	CE04W1H220M
D176	276 0432 903	Diode 1SS270A		C401,402	254 4260 087	Electrolytic 10 μF/50V	CE04W1H100M
	393 4122 006	LCD(8189JP) Assy	LCD	C403,404	254 4258 002	Electrolytic 4.7 μF/35V	CE04W1V4R7M
RESISTORS GROUP (Not included Carbon Film ±5%, 1/4W Type. Refer to the Schematic Diagram for those Parts.)				C405	254 4260 045	Electrolytic 1 μF/50V	CE04W1H010M
△R156,256	244 2051 987	Metal Oxide Film 4.7 ohm, 1W	RS14B3A4R7JS (S)	C406,407	254 4256 017	Electrolytic 22 μF/25V	CE04W1E220M
△R159,259	244 2055 941	Metal Oxide Film 330 ohm, 1W	RS14B3A331JS (S)	C410	253 9036 006	BC Ceramic 0.1 μF/25V	CK45-1E104Z
△R170,371	241 2377 947	Carbon Film 100 ohm, 1/4W (N.B)	RD14B2E101JNBS	C411	254 4254 035	Electrolytic 47 μF/16V	CE04W1C470M
△R176,377	244 2043 982	Metal Oxide Film 0.22 ohm, 1W	RS14B3AR22JS (S)	C412,413	254 4355 002	Electrolytic 6800 μF/50V	CE04W1H682MDL
△R178	244 2052 973	Metal Oxide Film 560 ohm, 1W	RS14B3A561JS (S)	C414	254 4256 790	Electrolytic 2200 μF/25V	CE04W1E222MC
				C415~418	253 1024 003	Ceramic 0.01 μF/50V	CK45F1H103Z

RECEIVER SECTION

1U-2278B TUNER UNIT PARTS LIST for Europe model
1U-2278C TUNER UNIT PARTS LIST for U.K. model

Ref. No.	Part No.	Part Name	Remarks	Qty
C419	254 4254 035	Electrolytic 47 µF/16V	CE04W1C470M	
C420	254 4254 006	Electrolytic 10 µF/16V	CE04W1C100M	
C421	256 1042 000	Metalized 0.1 µF/250V	CF93A2E104K	
C422	254 4254 006	Electrolytic 10 µF/16V	CE04W1C100M	
C423	254 4254 035	Electrolytic 47 µF/16V	CE04W1C100M	
C424	254 4254 006	Electrolytic 10 µF/16V	CE04W1C100M	
C425	254 4254 035	Electrolytic 47 µF/16V	CE04W1C470M	
C452	254 4192 029	Electrolytic 47 µF/10V	CE04W1A470M	
C453	253 1024 003	Ceramic 0.01 µF/50V	CK45F1H103Z	
C454	253 1180 002	Ceramic 680pF/50V	CK45B1H681K (DD-3)	
C801,802	255 1211 025	Film 0.01 µF/50V	CK93M1H103J Europe model only	
C803,804	253 9038 907	BC Ceramic 0.047 µF/50V	CK45F1H473Z (BC) Europe model only	
C805	253 1024 003	Ceramic 0.01 µF/50V	CK45F1H103Z Europe model only	
OTHERS PARTS GROUP				
		(P.W. Board)		(1)
	202 0040 909	Fuse Clip		2
	212 5606 905	Tact Switch (Light Touch Switch)		24
	212 5604 910	Tact Switch (Light Touch Switch)	POWER	1
L101,201	235 0007 007	Inductor	1 µH	2
△L301	232 9005 001	Line Filter	for Motor	1
X101	399 9018 003	Ceramic Vibrator	CFST4.00MGW	1
	417 0373 008	Heat Sink	for +15C -15	1
	470 0012 022	Pan Screw 3X12 (With Washer, Spring Washer)		5
	417 0307 011	Heat Sink	+5 (for LED, VR)	1
	417 0253 013	Radiator	+12V	1
△F106	206 1015 029	Fuse 1A	F106	1
RL101	214 0128 002	Relay (DH24D2)		1
	449 0055 302	LCD Holder		1
	204 8370 004	Head Phone Jack	D3.6φ	1
	205 0690 002	4P Speaker Terminal		1
CB102	204 8284 022	15P System Socket		1
	204 8391 009	1P Pin Jack	Black	1
CN05C	205 0233 058	5P EH Connector Base		1
CN10C	205 0375 000	10P Connector Base (KR-PH)		1
CN12A	205 0375 026	12P Connector Base (KR-PH)		1
CN10A,B,D	205 0535 057	10P Connector Base (KR-PH)		3
CN10D	205 0536 056	10P Connector Socket		1
CN05A	205 0535 073	5P Connector Base		1
CN03A	205 0343 032	3P Connector Base (KR-PH)		1
CN06A	205 0343 061	6P Connector Base (KR-PH)		1
CN05B,05B	205 0185 054	5P Wire Holder		2
CN05C	203 8303 007	5P EH-SCN Connector Cord		1
CN03C	203 4456 068	3P KR-DA Connector Cord	ℓ=100	1
CN06A	204 0204 000	6P KR-DA Connector Cord	ℓ=100	1
CN10D	204 0385 024	10P KR-DS Connector Cord	ℓ=170	1
CN12B	204 9284 024	12P KR-DA Connector Cord	ℓ=150	1
	203 0382 071	1P SIN Connector Ass'y	White ℓ=170	1
	203 0422 038	1P Contact Ass'y	Black ℓ=75	1
	002 0016 090	5C Ribbon Cable	ℓ=250	1
	203 0481 008	1P SIN Connector Ass'y	Black ℓ=100 for GND	1
	203 0481 024	1P SIN Connector Ass'y	Gray ℓ=210	2
CN03B	203 4580 028	3P KR-DA Connector Cord		1
	203 4689 000	3P KR-DS Connector Cord		1
CN-2	001 0059 038	Vinyl Wire Ass'y		1
CN-1	203 0495 007	1P SIN Connector Ass'y		1
	415 0366 030	UL tube (2) Clear		1

Ref. No.	Part No.	Part Name	Remarks
SEMICONDUCTORS GROUP			
IC001	263 0421 002	IC LA1267	
IC002	263 0584 004	IC LA3410	
IC003	262 0703 002	IC LM7000	
IC120	263 0609 002	IC NJM2068DDC	
TR001	275 0051 909	FET 2SK161 (GR)	
TR002	273 0025 023	Transistor 2SC461 (C)	
TR003~006	273 0317 906	Transistor 2SC2458 (BL)	
TR007	275 0053 907	FET 2SK365 (BL/GR)	
TR008	273 0317 906	Transistor 2SC2458 (BL)	
TR009~011	269 0093 904	Transistor DTA114ES (47K-47K)	built in Resistor
TR012,013	273 0317 906	Transistor 2SC2458 (BL)	
TR014	269 0093 904	Transistor DTA144ES (47K-47K)	built in Resistor
TR015,016	273 0317 906	Transistor 2SC2458 (BL)	
TR019	269 0040 902	Transistor DTC114ES (47K-47K)	built in Resistor
D001	276 0432 903	Diode 1SS270A	
D002~005	276 0302 004	Diode SVC321SDA-D-2	Varicap
D006~009	276 0432 903	Diode 1SS270A	
D171,271	276 0432 903	Diode 1SS270A	
RESISTORS GROUP (Not included Carbon Film ±5%, 1/4W Type. Refer to the Schematic Diagram for those Parts.)			
△R021	241 2376 964	Carbon Resistor 100kΩ 1/4W (N.B.)	RD14B2E470JNBS
VR001	211 6047 049	Semi Fixed Resistor 22k ohm	V06PB223
CAPACITORS GROUP			
C001	253 1181 014	Ceramic 0.022 µF/50V	CK45F1H223Z (DD-3)
C002	254 4254 006	Electrolytic 10 µF/16V	CE04W1C100M
C003,004	253 1181 001	Ceramic 0.01 µF/50V	CK45F1H103Z (DD-3)
C005~007	253 1181 014	Ceramic 0.022 µF/50V	CK45F1H223Z (DD-3)
C008	254 4260 061	Electrolytic 3.3 µF/50V	CE04W1H3R3M
C009	253 4538 046	Ceramic 100pF/50V	CC45SL1H101J (DD-3)
C010	254 4260 045	Electrolytic 1 µF/50V	CE04W1H010M
C011	253 1181 001	Ceramic 10 µF/50V	CK45F1H103Z (DD-3)
C012	254 4254 006	Electrolytic 10 µF/16V	CE04W1C100M
C013	253 1181 014	Ceramic 0.022 µF/50V	CK45F1H223Z (DD-3)
C014	253 1181 001	Ceramic 0.01 µF/50V	CK45F1H103Z (DD-3)
C015	254 4260 074	Electrolytic 4.7 µF/50V	CE04W1H4R7M
C016	254 4260 061	Electrolytic 3.3 µF/50V	CE04W1H3R3M
C017	253 4538 004	Ceramic 68pF/50V	CC45SL1H680J (DD-3)
C018	254 4254 006	Electrolytic 10 µF/16V	CE04W1C100M
C019	253 1181 014	Ceramic 0.022 µF/50V	CK45F1H223Z (DD-3)
C020	253 1181 001	Ceramic 0.01 µF/50V	CK45F1H103Z (DD-3)
C021	253 9030 073	BC Ceramic 0.015 µF/25V	CK45-1E153K
C022	253 9031 027	BC Ceramic 0.1 µF/25V	CK45-1E104K
C023	253 4536 048	Ceramic 10pF/50V	CC45SL1H100D (DD-3)
C024	253 1182 000	BC Ceramic 0.047 µF/50V	CK45F--473Z
C024	254 4260 061	Electrolytic 3.3 µF/50V	CE04W1H3R3M
C025	254 4260 032	Electrolytic 0.47 µF/50V	CE04W1HR47M
C026	254 4254 006	Electrolytic 10 µF/16V	CE04W1C100M
C027	254 4260 045	Electrolytic 1 µF/50V	CE04W1H010M
C028	253 1182 000	BC Ceramic 0.047 µF/50V	CK45F--473Z
C029	254 4254 035	Electrolytic 47 µF/16V	CE04W1C470M
C030	254 3056 014	Electrolytic 1 µF/50V (Bipole)	CE04D1H010MBP
C031	255 4201 984	Film 560pF/50V	CQ93P1H561J
C032~034	253 1179 068	Ceramic 330pF/50V	CK45B1H331K (DD-3)
C035,036	254 4254 006	Electrolytic 10 µF/16V	CE04W1C100M
C037,038	253 4536 048	Ceramic 15pF/50V	CC45SL1H150J (DD-3)
C039	254 4254 006	Electrolytic 10 µF/16V	CE04W1C100M
C040	253 1181 001	Ceramic 0.01 µF/50V	CK45F1H103Z
C041	253 4538 004	Ceramic 68pF/50V	CC45SL1H680J (DD-3)
C043	253 1181 014	Ceramic 0.022 µF/50V	CK45F1H223Z
C044	253 1179 042	Ceramic 220pF/50V	CK45B1H221K (DD-3)
C045	253 3632 008	Ceramic 160pF/50V	CC45SL1H161J
C046	255 4201 942	Film 390pF/50V	CQ93P1H391J

Ref. No.	Part No.	Part Name	Remarks
C047	253 4536 048	Ceramic 15pF/50V	CC45SL1H150J (DD-3)
C048,049	253 1181 001	Ceramic 0.01 µF/50V	CK45F1H103Z (DD-3)
C050	254 3056 014	Electrolytic 1 µF/50V (Bipole)	CE04D1H010MBP
C051	253 1181 014	Ceramic 0.022 µF/50V	CK45F1H223Z (DD-3)
C060	253 1181 001	Ceramic 0.01 µF/50V	CK45F1H103Z (DD-3)
C104	253 4238 046	Ceramic 100pF/50V	CC45SL1H101J (DD-3)
C171,172, 271,272	253 1179 042	Ceramic 220pF/50V	CK45B1H221K (DD-3) Europe model only
C173,273	254 4254 006	Electrolytic 10 µF/16V	CE04W1C100M
C175,275	255 1234 909	Film 0.012 µF/50V	CQ93M1H123K
C176,276	255 1227 903	Film 0.0033 µF/50V	CQ93M1H332K
C177,277	254 4250 026	Electrolytic 100 µF/6.3V	CE04W0J101M
C178,278	254 4254 006	Electrolytic 10 µF/16V	CE04W1C100M
C179,180	253 1181 014	Ceramic 0.022 µF/50V	CK45F1H223Z (DD-3)
C204	253 4538 046	Ceramic 100pF/50V	CC45SL1H101J (DD-3)
C701	253 1181 001	Ceramic 0.01 µF/50V	CK45F1H103Z (DD-3)
C702	254 4260 045	Electrolytic 1 µF/50V	CE04WH010M
TC001	213 0041 063	Trimmer Condenser	
TC002	213 0034 009	Trimmer Condenser	GTZ-51C
OTHERS PARTS GROUP			
CF001,002	261 0064 007	Ceramic Filter	SFT10.7MS2
CF003	261 0046 009	AM Ceramic Filter	SFZ450A
CF004	261 0101 009	AM Ceramic Filter	BFU450C4
CF005	261 0103 007	AM Ceramic Filter	CSB456F11
L101,102, 201,202	235 9003 002	FTZ Choke Coil	Europe model only
X001	399 0040 009	X'tal (7.2MHz)	
T001	231 2905 008	FM IF DET Trans (A)	
T002	231 2906 007	FM IF DET Trans (B)	
T003	231 3903 009	AM IFT	
T011	231 1131 004	LW Ant. Trans	
T012	231 0923 008	MW Ant. Trans	
T013	231 1135 002	LW OSC Coil	
T014	231 1130 007	MW OSC. Coil	
LP001	232 9002 004	MPX Filter	ABW-07
LP002	232 0152 005	Anti Birdie Filter	
	216 0079 005	FM Front End	
	205 0433 007	3P Ant. Terminal (DIN.)	for Ant.
	204 8346 009	6P Pin Jack (S-GND)	Red, White
CB101	204 2429 003	7P System Socket	
	203 0478 008	1P SIN Connector Ass'y	White ℓ=150
	203 0478 011	1P SIN Connector Ass'y	Yellow ℓ=150
CN05A	205 0536 072	5P Connector Socket	
CN10A,10B	205 0536 056	10P Connector Socket	
CN06B,06B	205 0185 067	6P Wire Holder	
	002 0008 011	6C Ribbon Cable	
△F101	206 1015 029	Fuse 1A (T)	1
△F102~105	206 1015 058	Fuse 1.6A (T)	4
	202 0040 909	Fuse Clip	10
	513 0654 088	Fuse Label (T1.0A)	1
	203 0422 038	1P Contact Ass'y	Black ℓ=75

RECEIVER SECTION

WIRING DIAGRAM

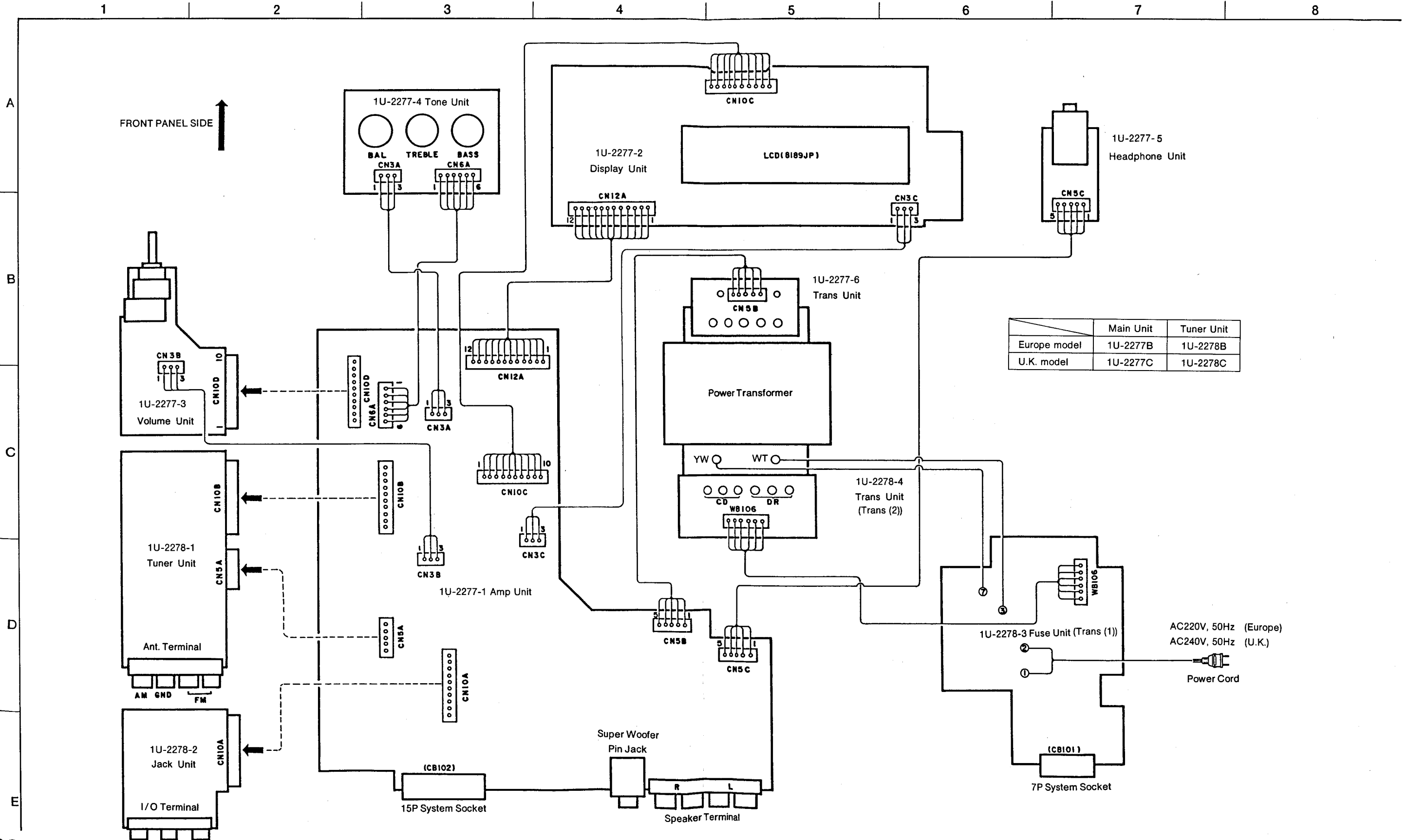

SCHEMATIC DIAGRAM

2

3

4

5

6

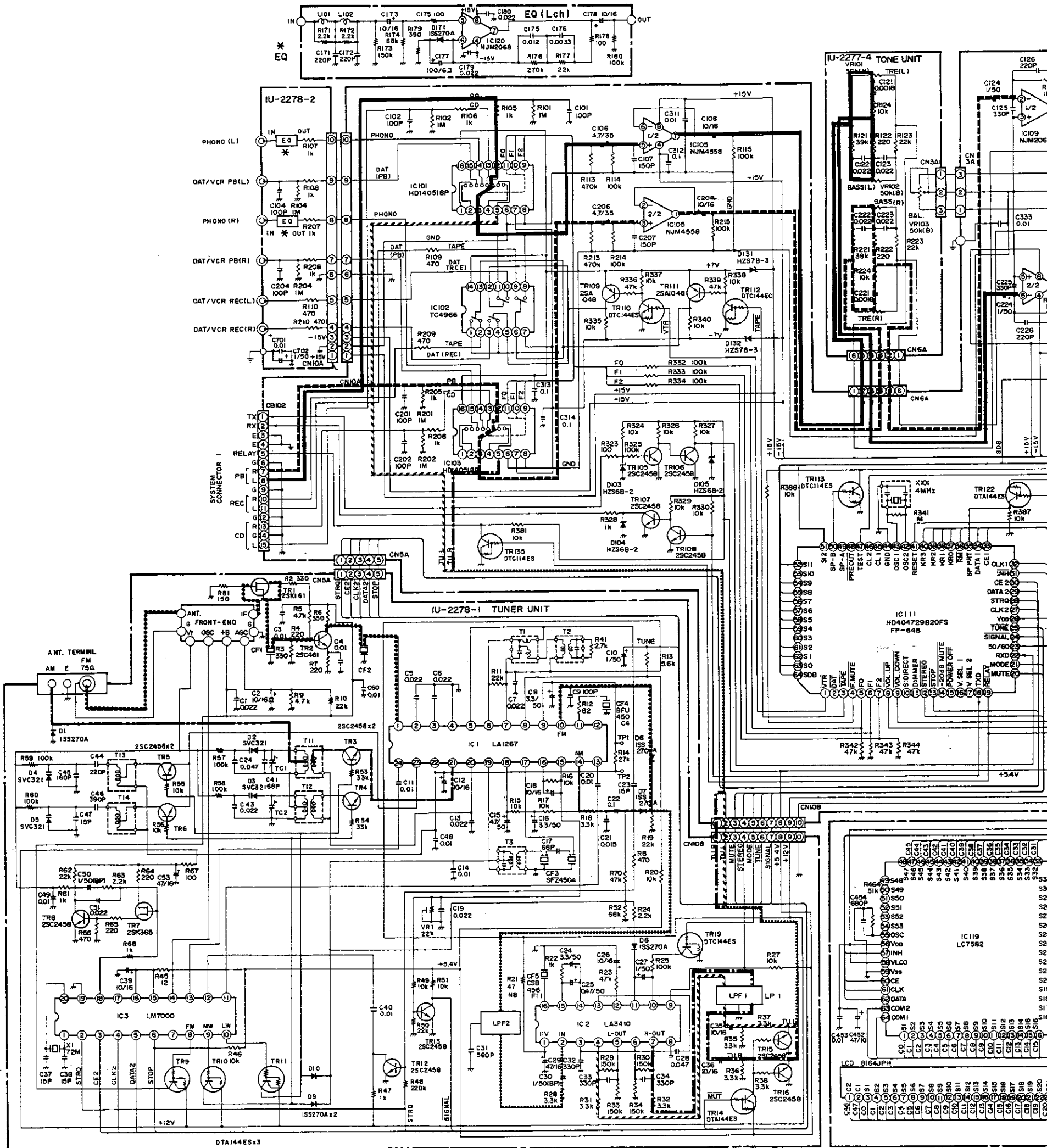

WARNING: Parts marked with this symbol  have critical characteristics. Use ONLY replacement parts recommended by the manufacturer.

CAUTION: Before returning the unit to the customer, make sure you make either (1) a leakage current exceeds 0.5 milliamps, or if the resistance from chassis to defective.

RECEIVER SECTION

SCHEMATIC DIAGRAM

5 6 7 8 9 10

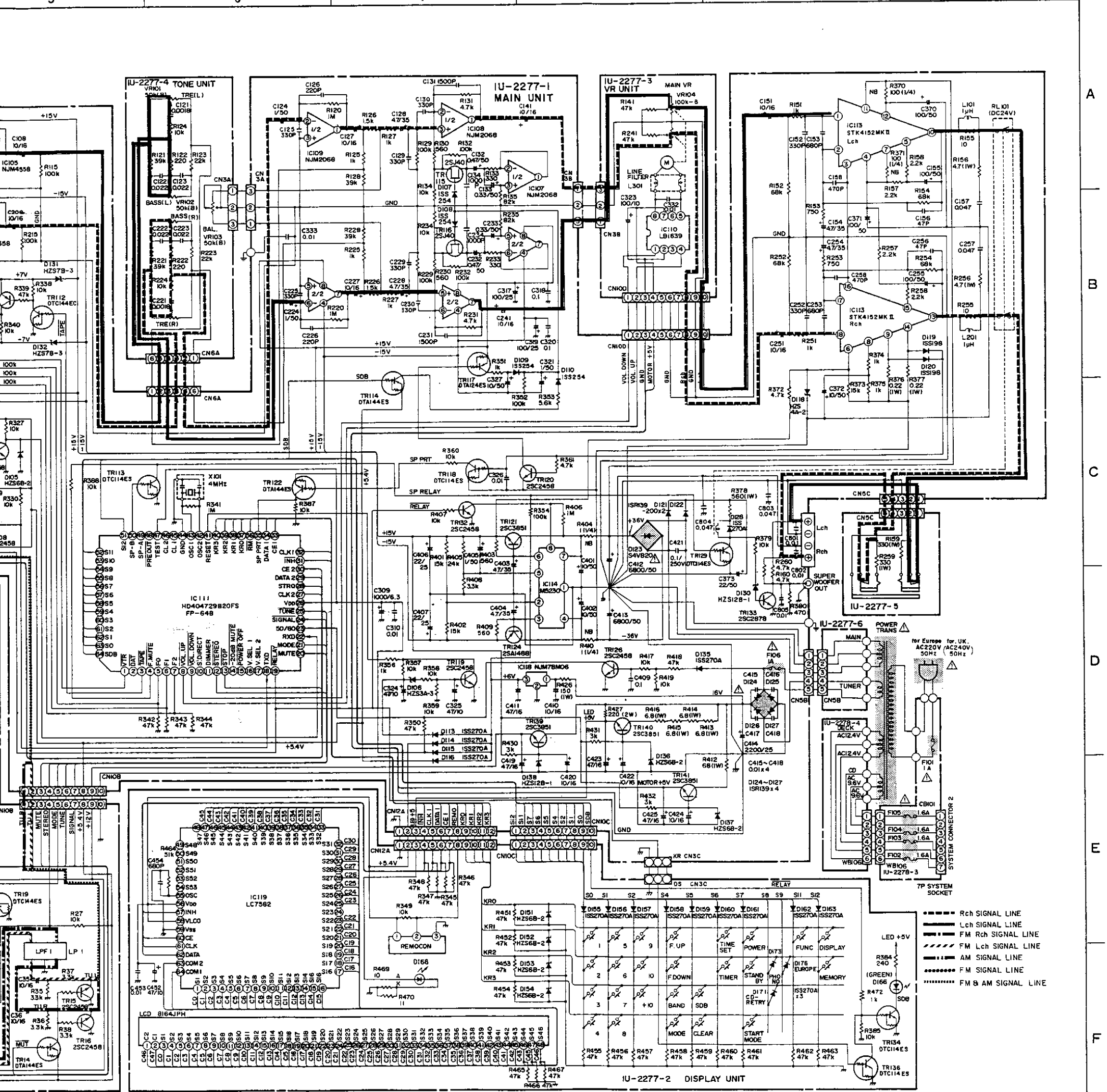

WARNING:
Parts marked with this symbol Δ have critical characteristics. Use ONLY replacement parts recommended by the manufacturer.

CAUTION:
Before returning the unit to the customer, make sure you make either (1) a leakage current check or (2) a line to chassis resistance check. If the leakage current exceeds 0.5 milliamps, or if the resistance from chassis to either side of the power cord is less than 240 k ohms, the unit is defective.

WARNING
DO NOT return the unit to the customer until the problem is located and corrected.

NOTES
ALL RESISTANCE VALUES IN OHM K=1,000 OHM M=1,000,000 OHM
ALL CAPACITANCE VALUES IN MICRO FARAD P=MICRO-MICRO FARAD
EACH VOLTAGE AND CURRENT ARE MEASURED AT NO SIGNAL INPUT CONDITION.
CIRCUIT AND PARTS ARE SUBJECT TO CHANGE WITHOUT PRIOR NOTICE.

RECEIVER SECTION

EXPLODED VIEW OF PARTS LIST

Ref. No.	Part No.	Part Name	Remarks	Qty
1	105 0974 415	Rear Panel		1
2	417 9060 207	Radiator		1
3	104 0253 010	Foot Ass'y		4
4	412 3331 115	Trans Bracket		1
5	415 9016 019	P.C.B Holder		1
6	1U- 2277 B	Main Unit Ass'y	for Europe model	1 ^s
	1U- 2277 C	Main Unit Ass'y	for U.K. model	1 ^s
6-1	-	Amp. Unit		(1)
6-2	-	Display Unit		(1)
6-3	-	Volume Unit		(1)
6-4	-	Tone Unit		(1)
6-5	-	Head Phone Unit		(1)
6-6	-	Trans Unit		(1)
7	232 9005 001	Line Filter		1
8	254 4355 002	Chemicon 6800 μF/50V	C412, 413	2
9	254 4256 790	Chemicon 2200 μF/25V	C414	1
10	214 0128 002	Relay (DH24D2)		1
11	211 9067 000	Variable Resistor 100k ohm	Main Volume	1
12	211 9103 003	Variable Resistor 50k ohm	Tone	2
13	211 9105 001	Variable Resistor 50k ohm	Balance	1
14	265 0073 003	IC STK4152II		1
15	393 4122 006	LCD Ass'y (8189JP)		1
16	204 8370 004	Head Phone Jack (φ 3.6)		1
17	205 0690 002	4P Push SP. Terminal	Speaker	1
18	204 8284 022	15P System Socket		1
19	204 8391 009	1P Pin Jack (Black)	CB102	1
20	206 1015 029	Fuse (0.5A)	F106	1
21	1U- 2278 B	Tuner Unit Ass'y	for Europe model	1 ^s
	1U- 2278 C	Tuner Unit Ass'y	for U.K. model	1 ^s
21-1	-	Tuner Unit		(1)
21-2	-	Jack Unit		(1)
21-3	-	Trans (1) Unit		(1)
21-4	-	Trans (2) Unit		(1)
22	411 1099 139	Chassis		1
23	414 0628 102	Shield Sheet		1
24	216 0079 005	FM Front End		1
25	205 0433 007	3P Ant. Terminal (DIN)	Antenna	1
26	204 8346 009	6P Pin Jack (S-GND)		1
27	204 2429 003	7P System Socket		1
28	233 5922 000	Power Trans.	for Europe model	1
28	233 5923 000	Power Trans.	for U.K. model	1
29	409 0052 019	Holder (A)		2
30	445 0056 008	Cord Bush		1
31	206 2088 018	AC Cord	for Europe model	1
	206 2024 006	AC Cord with Label	for U.K. model	1
32	144 2132 111	Front Panel Ass'y		1
33	103 1472 318	Inner Panel Ass'y		1
34	435 0113 009	Latch (Y3Y18)		1
35	113 1460 013	Power Knob		1
36	112 0645 153	Head Phone Knob		3
37	144 2133 110	Trap Door		1
38	401 0126 200	Door Hinge (L)		1
39	401 0127 209	Door Hinge (R)		1
40	112 0691 110	Volume Knob Ass'y		1
41	146 1279 110	Side Panel (L) Ass'y		1
42	146 1281 111	Side Panel (R) Ass'y		1
43	102 0478 129	Top Cover		1
44	461 0539 080	Rubber Sheet	7×10×70 for Rear Panel	1
45	441 1389 002	P.W.B Bracket		1
46	445 0048 003	Cord Holder ℓ=76		1
47	412 3339 201	IC Holder Bracket		1
48	412 3332 017	Radiator Cover		1
49	513 1845 100	Rating Sheet	for Europe model	1
	513 1845 113	Rating Sheet	for U.K. model	1
50	513 8253 009	Approval Mark	for Europe model only	1
51	206 6015 029	Fuse (1A)	F101	1
52	206 1015 058	Fuse (1.6A)	F102-105	4
53	461 0501 005	Rubber Sheet		1
54	461 0577 055	Rubber Sheet	10×15×25 for Chassis	2
55	449 0055 302	LCD Holder		1
61	461 9012 029	Cushion		1
62	513 1869 005	Caution Label	for U.K. model only	1
63	513 1900 003	Homologation Label	for U.K. model only	1
SCREWS				
71	473 7500 044	Tapping Screw (P) 3×8	Black	9
72	473 7002 034	Tapping Screw (S) 3×6	Black	20
73	473 7007 000	Tapping Screw (S) 4×8	Black	8
74	473 7500 015	Tapping Screw (P) 3×8		7
75	473 7026 007	Tapping Screw (S) 4×6	Black	4
77	473 7005 044	Tapping Screw (S) 3×20		2
78	473 7015 018	Tapping Screw (S) 3×8	Black	1
79	425 0233 005	Adjust Washer	10.3 Black Put on Hinge	1
80	425 0233 018	Adjust Washer	10.3 Clear Put on Hinge	1
PACKING & ACCESSORIES (Not included EXPLODED VIEW)				
101	505 0154 082	Cabinet Cover	600×600	1
102	503 0980 001	Cushion		2
103	501 1560 026	Sleeve Carton		1
104	513 1389 006	Control Card Base		1
105	513 1349 004	Thermal Carbon Film		1
106	501 1582 004	Master Carbon		1

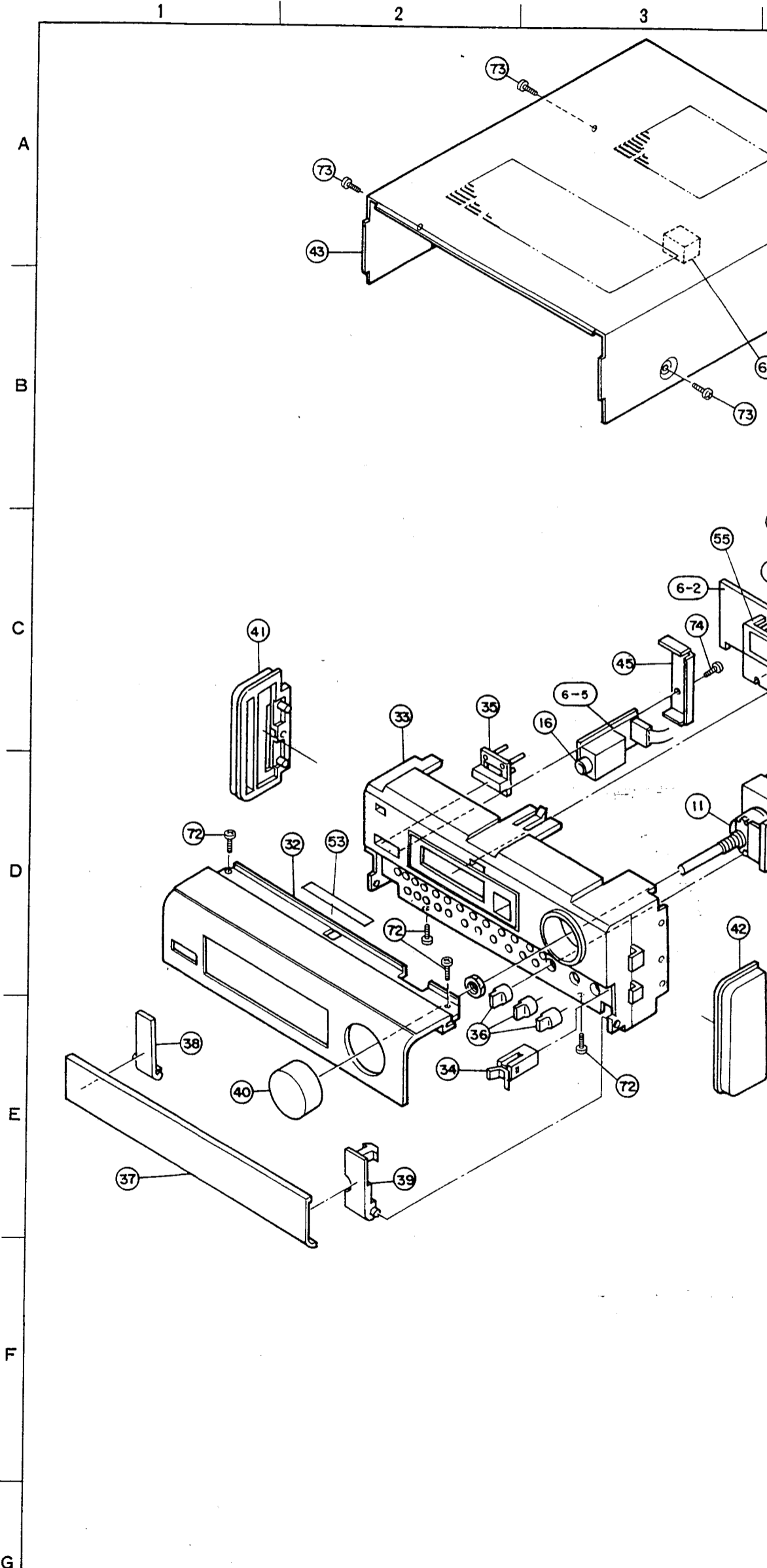

EXPLODED VIEW

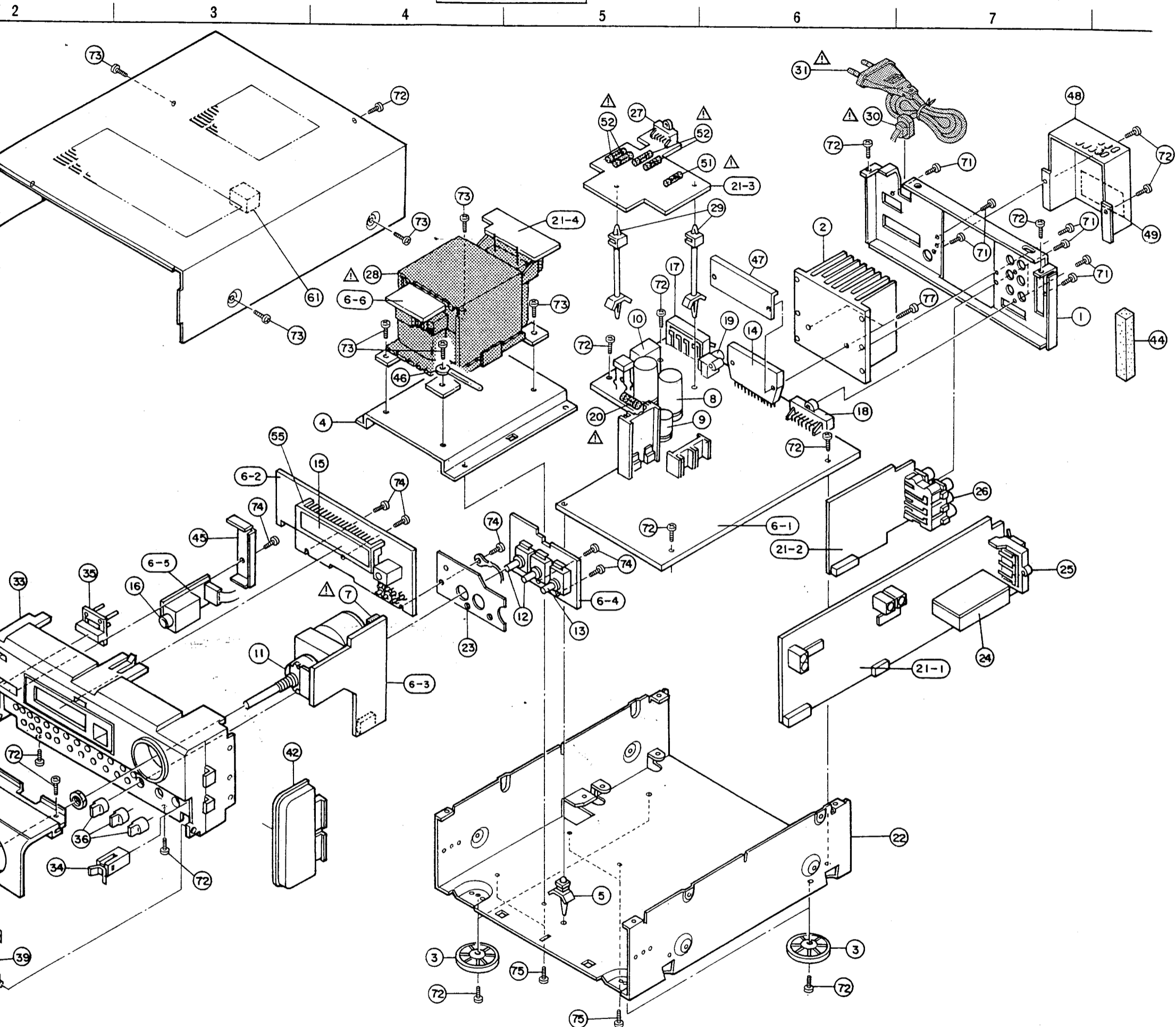

NOTE FOR PARTS LIST

- Part indicated with the mark "●" are not always in stock and possibly to take a long period of time for supplying, or in some case supplying of part may be refused.
- When ordering of part, clearly indicate "1" and "1" (i) to avoid mis-supplying.
- Ordering part without stating its part number can not be supplied.
- Part indicated with the mark "★" is not illustrated in the exploded view.

WARNING:

Parts marked with this symbol Δ  have critical characteristics. Use ONLY replacement parts recommended by the manufacturer.

REMOTE CONTROLLER (RC-142)

RECEIVER SECTION

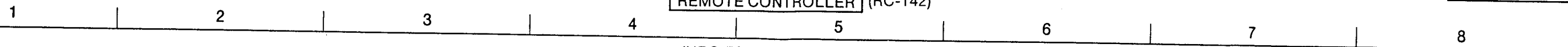

Schematic Diagram

(URC-70: 3990144002)

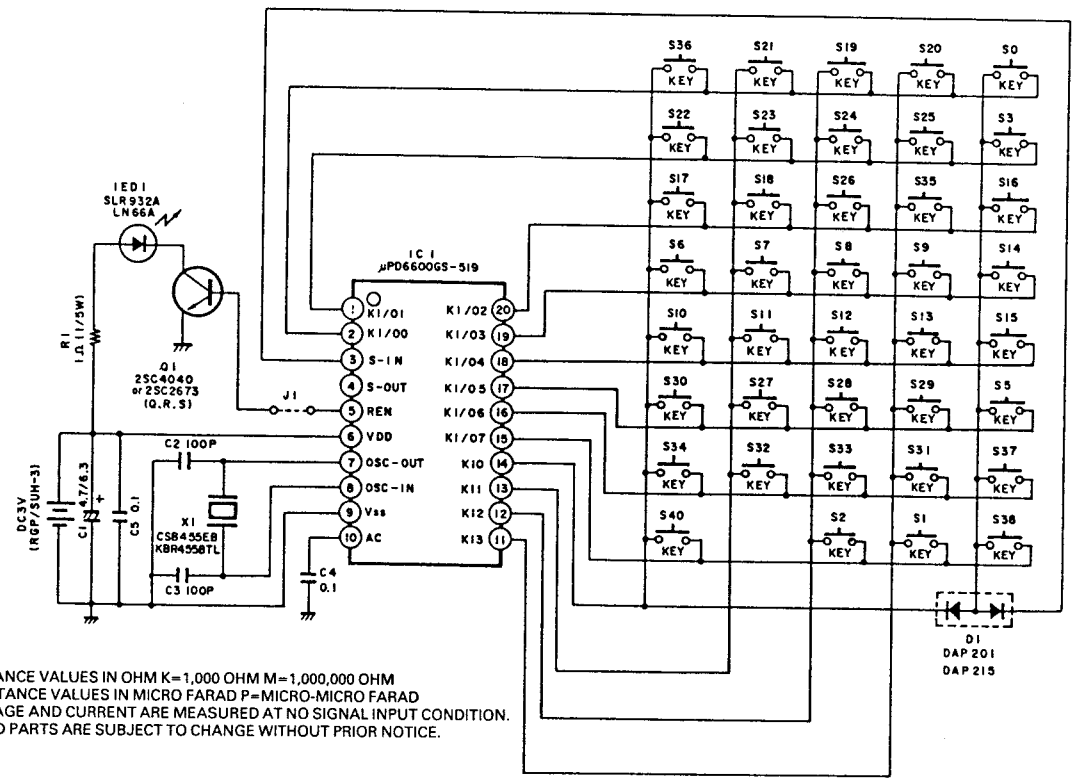

NOTES
 ALL RESISTANCE VALUES IN OHM K=1,000 OHM M=1,000,000 OHM
 ALL CAPACITANCE VALUES IN MICRO FARAD P=MICRO-MICRO FARAD
 EACH VOLTAGE AND CURRENT ARE MEASURED AT NO SIGNAL INPUT CONDITION.
 CIRCUIT AND PARTS ARE SUBJECT TO CHANGE WITHOUT PRIOR NOTICE.

IC
 μPD6600GD-519
 Pin Connection Diagram (Top View)

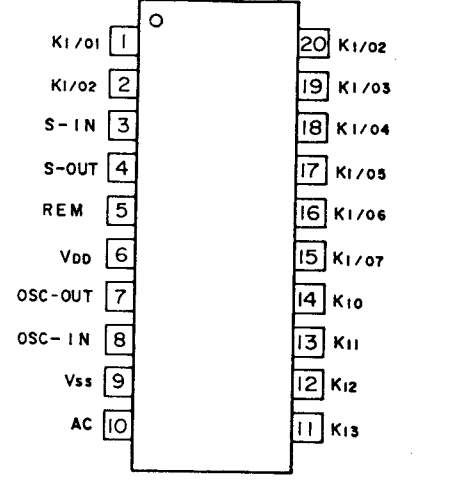

Block Diagram

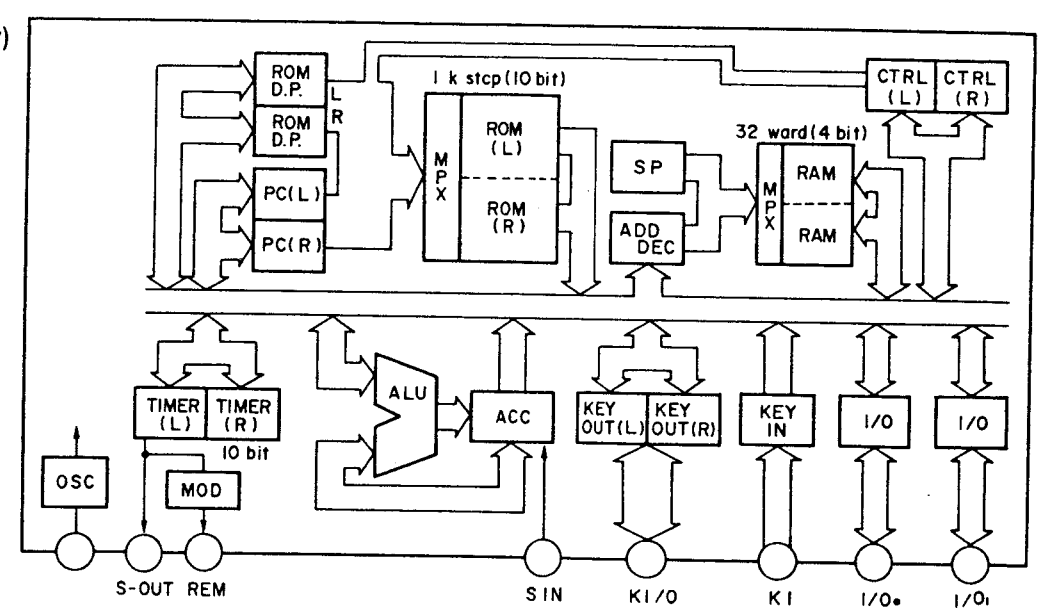

KEY NO.	FUNCTION	System code					Date code					Expansion code					HEX code (Wide use F)
		C1	C2	C3	C4	C5	C6	C7	C8	C9	C10	C11	C12	C13	C14	K	
S 0	POWER	0	0	1	1	0	0	0	0	0	1	0	1	0	0	0	000C0050
S 1	VOLUME ▲	0	0	1	1	0	1	0	1	0	0	1	0	0	0	000C001D	
S 2	VOLUME ▼	0	0	1	1	0	0	0	1	1	0	0	1	0	0	000C001C	
S 3	SLEEP	0	0	1	1	0	0	1	0	0	1	1	1	0	0	000C0072	
S 4	-	0	0	1	1	0	1	1	0	1	1	0	1	0	0	000C004B	
S 5	TUNER	0	0	1	1	0	1	0	0	1	1	0	1	0	0	000C0059	
S17	DIRECT CD	0	0	0	1	0	1	1	1	0	1	0	1	0	0	00080057	
S18	PROG CD	0	0	0	1	0	1	0	1	1	0	0	1	0	0	0008004D	
S19	▶ CD	0	0	0	1	0	0	1	1	1	0	1	0	0	0	0008005C	
S20	⏸ CD	0	0	0	1	0	1	0	1	1	1	0	1	0	0	0008005D	
S21	■ CD	0	0	0	1	0	0	1	1	1	1	0	1	0	0	0008005E	
S22	◀ CD	0	0	0	1	0	1	1	0	1	1	0	1	0	0	0008005B	
S23	▶▶ CD	0	0	0	1	0	0	1	0	1	1	0	1	0	0	0008005A	
S24	◀◀ CD	0	0	0	1	0	1	0	0	1	1	0	1	0	0	00080059	
S25	▶▶▶ CD	0	0	0	1	0	0	0	0	1	1	0	1	0	0	00080058	
S26	CANSEL CD	0	0	0	1	0	1	0	0	1	0	1	0	0	0	00080051	
S27	◀ DECK	0	0	1	0	0	1	1	1	0	0	1	1	0	0	00040067	
S28	■ DECK	0	0	1	0	0	0	1	1	1	0	1	1	0	0	0004006E	
S29	▶ DECK	0	0	1	0	0	0	0	1	1	0	1	1	0	0	0004006C	
S30	◀◀ DECK	0	0	1	0	0	1	1	0	1	0	1	1	0	0	0004006B	
S31	▶▶ DECK	0	0	1	0	0	0	1	0	1	0	1	1	0	0	0004006A	
S32	REC REC MUTE DECK	0	0	1	0	0	1	1	1	1	0	1	1	0	0	0004006F	
S33	REC REC PAUSE DECK	0	0	1	0	0	1	0	1	1	0	1	1	0	0	0004006D	
S34	OPEN/CLOSE DECK	0	0	1	0	0	0	1	0	0	1	1	1	0	0	00040072	
S35	TIME CE	0	0	0	1	0	1	1	0	0	1	0	1	0	0	00080053	
S36	OPEN/CLOSE CE	0	0	0	1	0	0	0	0	0	1	0	1	0	0	00080050	
S37	PHONO	0	0	1	1	0	0	0	1	0	1	0	1	0	0	000C0051	
S38	DAT/VCR	0	0	1	1	0	0	1	0	0	1	0	1	0	0	000C0052	
S40	SDB	0	0	0	1	0	0	1	0	1	0	1	1	0	0	000800EA	

TUNER key after being switched on

KEY NO.	FUNCTION	System code					Data code					Expansion code					HEX code (Wide use F)
		C1	C2	C3	C4	C5	C6	C7	C8	C9	C10	C11	C12	C13	C14	K	
S 6	1	0	0	1	1	0	0	1	0	0	0	0	1	0	0	0	000C0042
S 7	2	0	0	1	1	0	1	1	0	0	0	0	1	0	0	0	000C0043
S 8	3	0	0	1	1	0	0	0	1	0	0	0	1	0	0	0	000C0044
S 9	4	0	0	1	1	0	1	0	1	0	0	0	1	0	0	0	000C0045
S10	5	0	0	1	1	0	0	1	1	0	0	0	1	0	0	0	000C0046
S11	6	0	0	1	1	0	1	1	1	0	0	0	1	0	0	0	000C0047
S12	7	0	0	1	1	0	0	0	0	1	0	0	1	0	0	0	000C0048
S13	8	0	0	1	1	0	1	0	1	0	0	0	1	0	0	0	000C0049
S14	9	0	0	1	1	0	1	1	0	0	0	1	1	0	0	0	000C0063
S15	10	0	0	1	1	0	0	0	1	0	0	1	1	0	0	0	000C0064
S16	+10	0	0	1	1	0	1	1	1	1	0	1	1	0	0	0	000C006F

CD PROGRAM and DIRECT keys after being switched on

KEY NO.	FUNCTION	System code					Data code					Expansion code					HEX code (Wide use F)
		C1	C2	C3	C4	C5	C6	C7	C8	C9	C10	C11	C12	C13	C14	K	
S 6	1	0	0	0	1	0	0	1	0	0	0	0	1	0	0	0	00080042
S 7	2	0	0	0	1	0	1	1	0	0	0	0	1	0	0	0	00080043
S 8	3	0	0	0	1	0	0	0	1	0	0	0	1	0	0	0	00080044
S 9	4	0	0	0	1	0	1	0	1	0	0	0	1	0	0	0	00080045
S10	5	0	0	0	1	0	0	1	1	0	0	0	1	0	0	0	00080046
S11	6	0	0	0	1	0	1	1	1	0	0	0	1	0	0	0	00080047
S12	7	0	0	0	1	0	0	0	0	1	0	0	1	0	0	0	00080048
S13	8	0	0	0	1	0	1	0	0	1	0	0	1	0	0	0	00080049
S14	9	0	0	0	1	0	0	1	0	1	0	0	1	0	0	0	0008004A
S15	10	0	0	0	1	0	1	1	0	1	0	0	1	0	0	0	0008004B
S16	+10	0	0	0	1	0	0	0	1	1	0	0	1	0	0	0	0008004C

Transistors

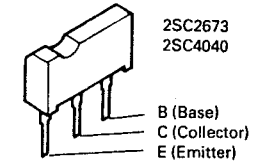

Diodes

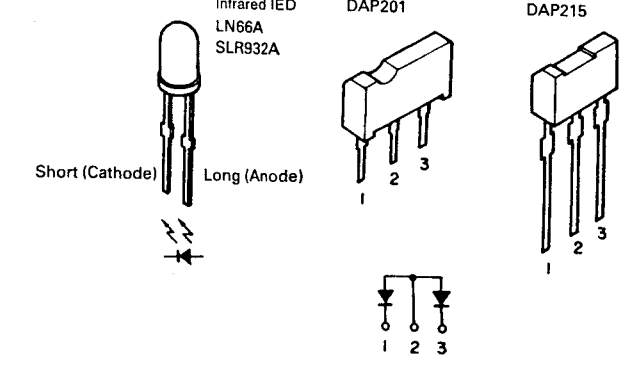

CASSETTE DECK SECTION

PART NAMES AND FUNCTIONS

CASSETTE DECK

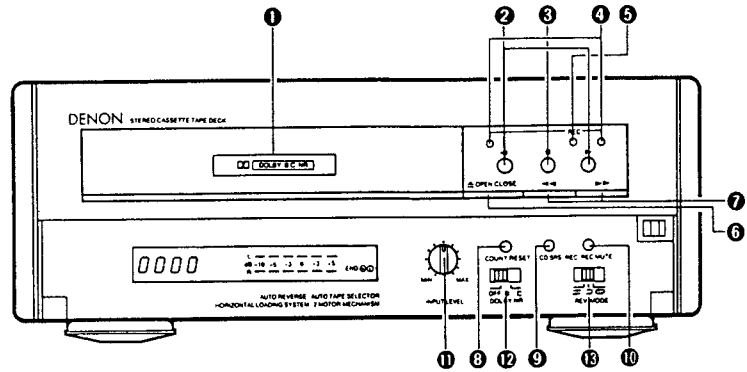

- 1 Cassette tray**
The cassette tray opens out when the OPEN/CLOSE button 6 is pressed. Insert the cassette tape with the side on which the tape is exposed facing away from you. To close the cassette tray, press the OPEN/CLOSE button 6 again.
- 2 ▶ (forward playback button):**
Press this button to record or play the tape in the forward direction.
- ◀ (reverse playback button):**
Press this button to record or play the tape in the reverse direction.
- 3 ■ (stop button):**
Press this button while the tape is moving to stop the tape.
- 4 Playback direction indicators**
This flashes during playback.
- 5 Recording indicator**
This lights when the recording or recording standby mode is set using the REC/REC MUTE button 10, and flashes during the recording mute mode.
- 6 ▲ OPEN/CLOSE button**
Press this button to open and close the cassette tray.
- 7 ◀◀ (rewind button):**
Press this button to rewind the tape. When pressed, the playback direction indicators 4 flash.
Also, if pressed during playback in the ▶ (forward) direction, the tape is rewound to the beginning of the current selection. If pressed during playback in the ◀ (reverse) direction, the tape is forwarded to the beginning of the next selection.
▶▶ (fast-forward button):
Press this button to fast-forward the tape. When pressed, the playback direction indicators 4 flash.
Also, if pressed during playback in the ▶ (forward) direction, the tape is forwarded to the beginning of the next selection. If pressed during playback in the ◀ (reverse) direction, the tape is rewound to the beginning of the current selection.
- 8 COUNTER RESET button**
Press this button to reset the tape counter to "0000".
- 9 CD SRS (CD synchronized recording button)**
Use this button for CD synchronized recording. Refer to Page 77.
- 10 REC/REC MUTE (recording/recording mute) button**
To record, press the REC/REC MUTE button and the ▶ PLAY button. If only the REC/REC MUTE button is pressed, the deck is set to the recording pause mode. If pressed during recording, the deck is set to the recording mute mode for approximately 5 seconds, after which it is set to the recording pause mode.
- 11 INPUT LEVEL control**
Use this control to set the recording level.
- 12 DOLBY NR selector switch**
Use this switch to select the Dolby NR mode, OFF, B or C. During playback, set this switch to the same mode in which the tape was recorded.
- 13 REV. MODE switch**
Use this to set the reverse mode to one of the following modes: (one side mode), (reverse mode), (continuous mode). In the continuous mode, the tape stops automatically after both sides are played five times. Refer to Page 11.

CASSETTE DECK DISPLAY

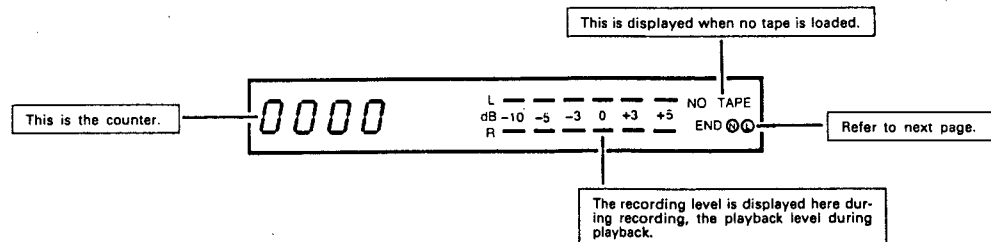

Dolby noise reduction manufactured under license from Dolby Laboratories Licensing Corporation. "DOLBY" and the double-D symbol are trademarks of Dolby Laboratories Licensing Corporation.

Remaining Tape Indicators - END, ④ and ⑤
These indicators notify that the tape is reaching the end during recording and playback. The indicators differ according to the diameter of the tape hub.

END : This starts flashing when the tape is nearing the end during recording or playback, then stops flashing and remains lit once the end of the tape is reached. After this, the indicator turns off as soon as another mode is set.

④ : For normal hubs, ④ and END light when the tape is nearing the end. Use these two indicators to determine the amount of tape remaining. The indicator lights when the tape is nearing the end, then turns off when the tape stops.

⑤ : When recording or playing tapes with large hubs, ⑤ and END light when the tape is nearing the end. Use these two indicators to determine the amount of tape remaining. The indicator lights when the tape is nearing the end, then turns off when the tape stops.

Example 1: About 5 minutes from the end of the tape during playback in the forward direction on a 60-minute tape with normal hubs:

Example 2: About 8 minutes from the end of the tape during playback in the forward direction on a 60-minute tape with large hubs:

Example 3: About 5 minutes from the end of the tape during playback in the reverse direction on a 60-minute tape with normal hubs:

Example 4: About 5 minutes from the end of the tape during playback in the reverse direction on a 60-minute tape with large hubs:

Hub diagrams:
Normal hub:
Large hub:

Table:

Tape length	Normal hub		Large hub	
	Playback in forward direction	Playback in reverse direction	Playback in forward direction	Playback in reverse direction
C-46	Approx. 1 minute	Approx. 5 minutes	Approx. 1 minutes	Approx. 5 minutes
C-60	Approx. 5 minutes	Approx. 5 minutes	Approx. 8 minutes	Approx. 5 minutes
C-90	Approx. 14 minutes	Approx. 6 minutes	-	-

* There are no C-90 tapes with large hubs.

CASSETTE DECK SECTION

REMOVAL OF EACH SECTION

(Follow this procedure in the reverse order when assembling.)

1. Removal of the top cover

- ① Remove the 5 screws which fasten the top cover.
- ② Press the ▲ OPEN/CLOSE button and eject the cassette tray.
- ③ Remove the loader panel (D) assembly in the direction of the arrow.
- ④ Press the ▲ OPEN/CLOSE button and retract the cassette tray.
- ⑤ Remove the 2 screws which fasten the front panel assembly. At this time, remove with care the connector which connects the main unit assembly and the front panel side assembly.

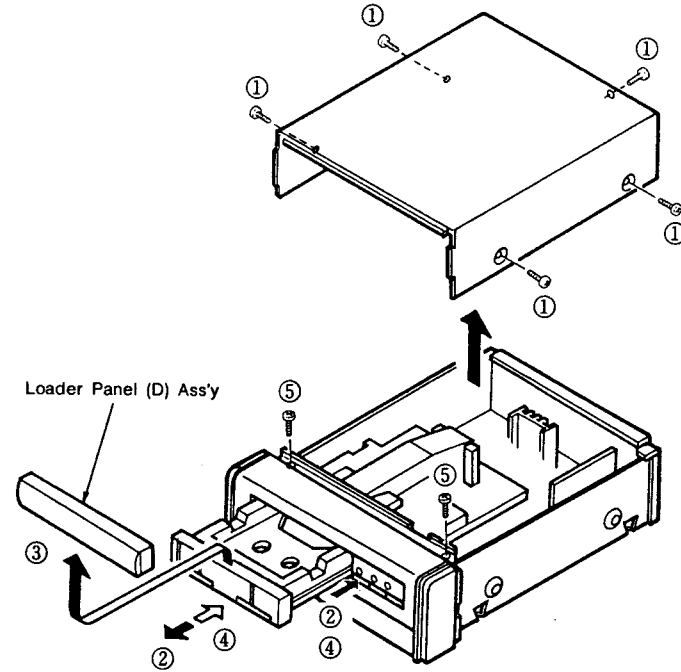

2. Removal of the front panel

- ⑥ Stand the main unit as illustrated in the diagram and remove the 2 screws which fasten the inner panel assembly.
- ⑦ Slightly loosen the screws of the 2 front legs.
- ⑧ Remove the hooks of the chassis from the inner panel assembly.
- ⑨ Remove the front panel assembly in the direction of the arrow.

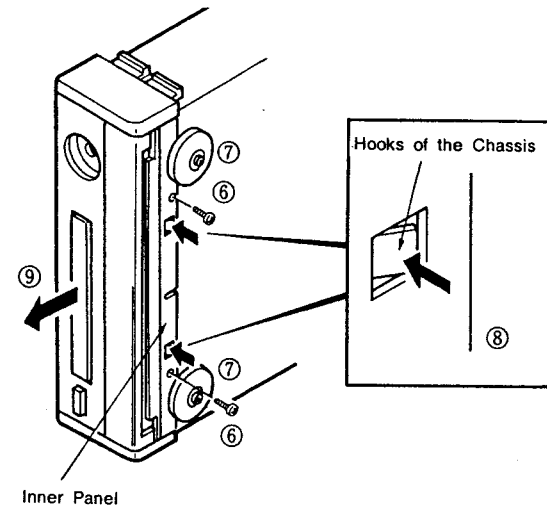

3. Removal of the printed wiring board assembly LCD UNIT (1U-2279-4)

- ⑩ Remove the 2 screws which fasten the LCD unit.
- ⑪ Remove the 6 screws which fasten the various boards.
- ⑫ Remove the hooks of the inner panel assembly from the board.

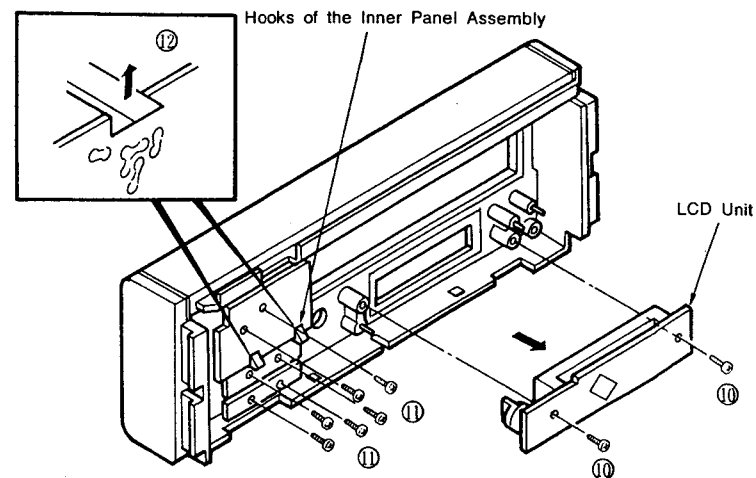

4. Removal of the cassette unit

- ⑬ After loosening the wire clamp band which bundles the wires, remove the connector which connects the cassette mechanism unit and the main unit assembly.
- ⑭ Remove the 4 screws which fasten the cassette mechanism unit.

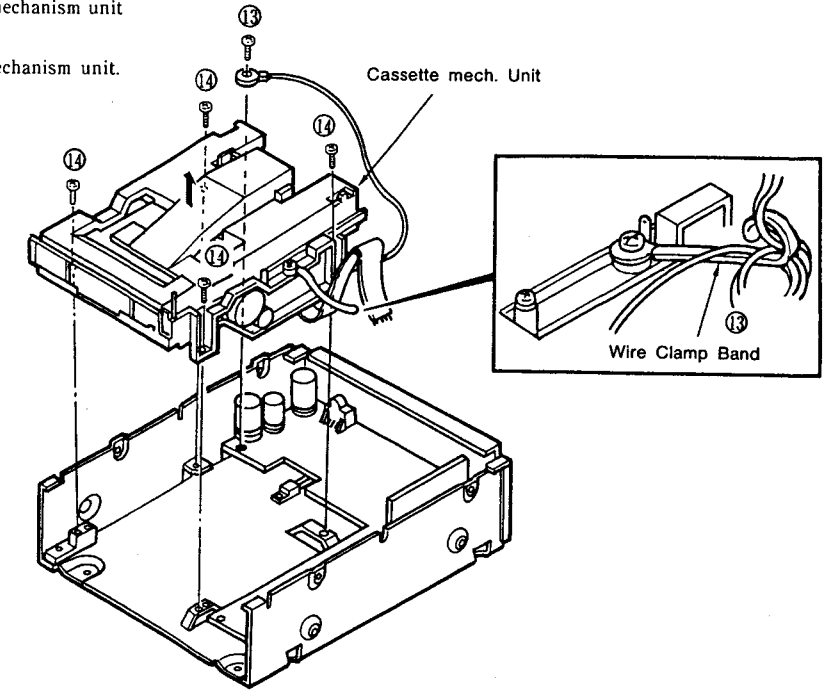

MAIN UNIT ASSEMBLY (1U-2279-1)

- ⑮ Remove the 6 screws which fasten the main unit assembly.
- ⑯ Use radio pliers or another suitable tool to remove the 2 PCB holders which fasten the main unit assembly.

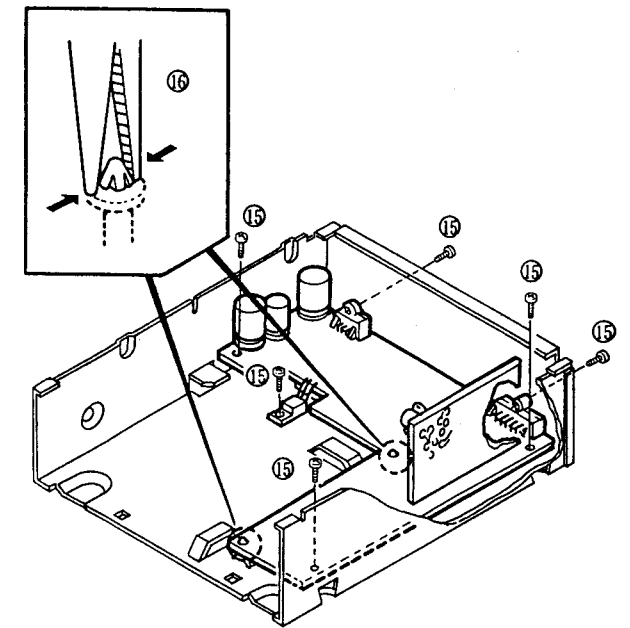

CASSETTE DECK SECTION

LEVEL DIAGRAM

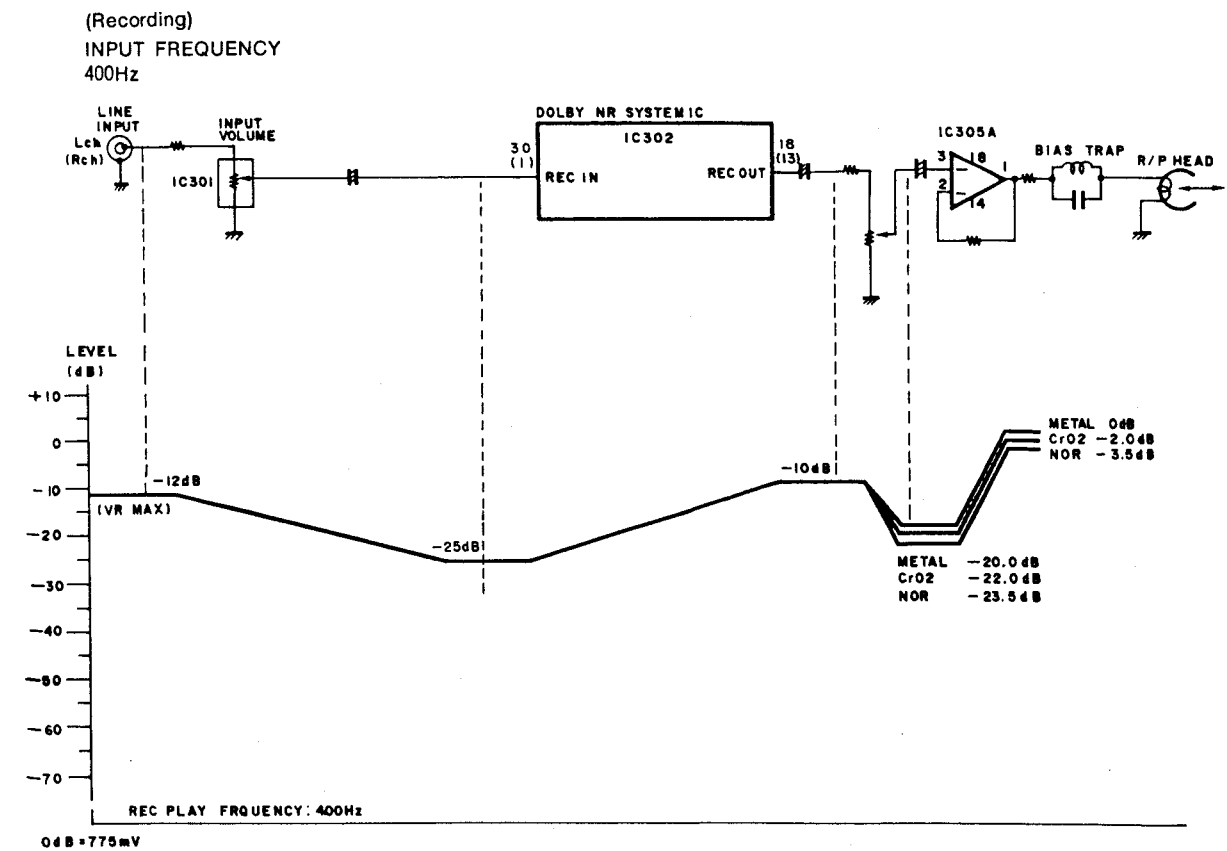
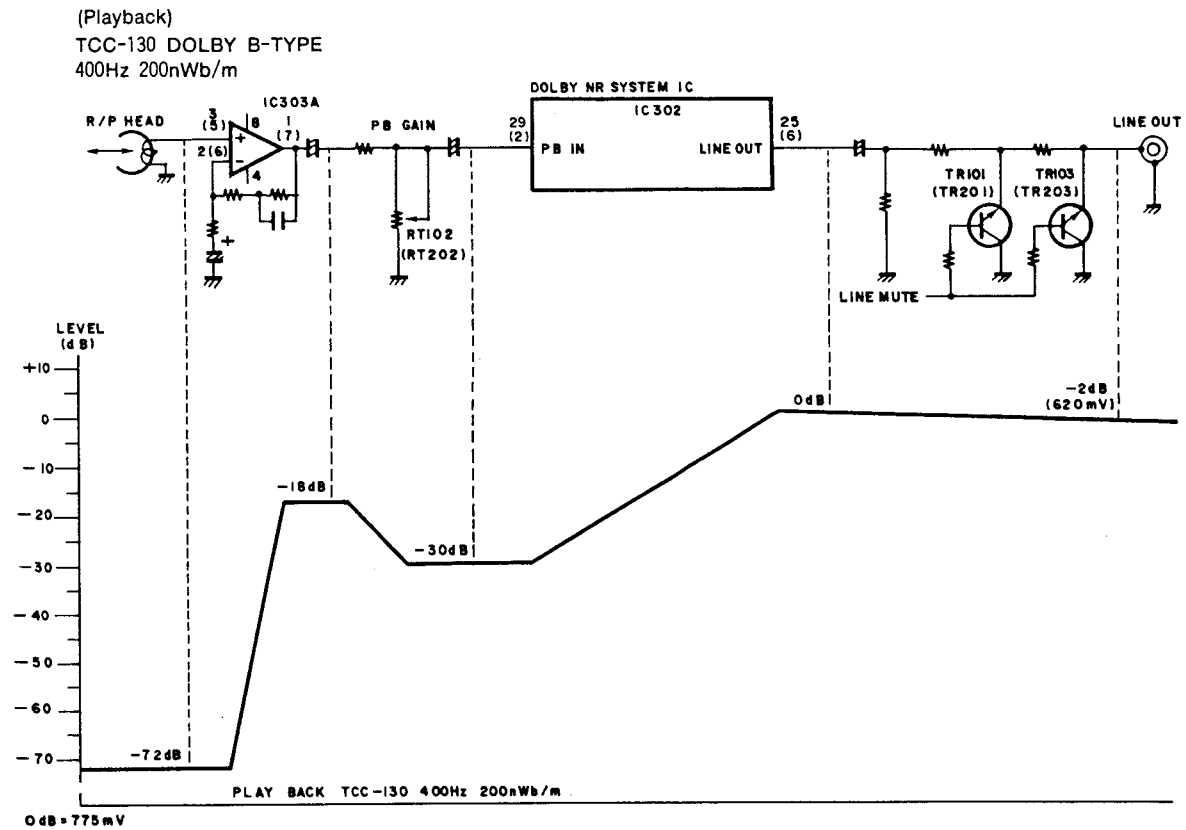

BLOCK DIAGRAM

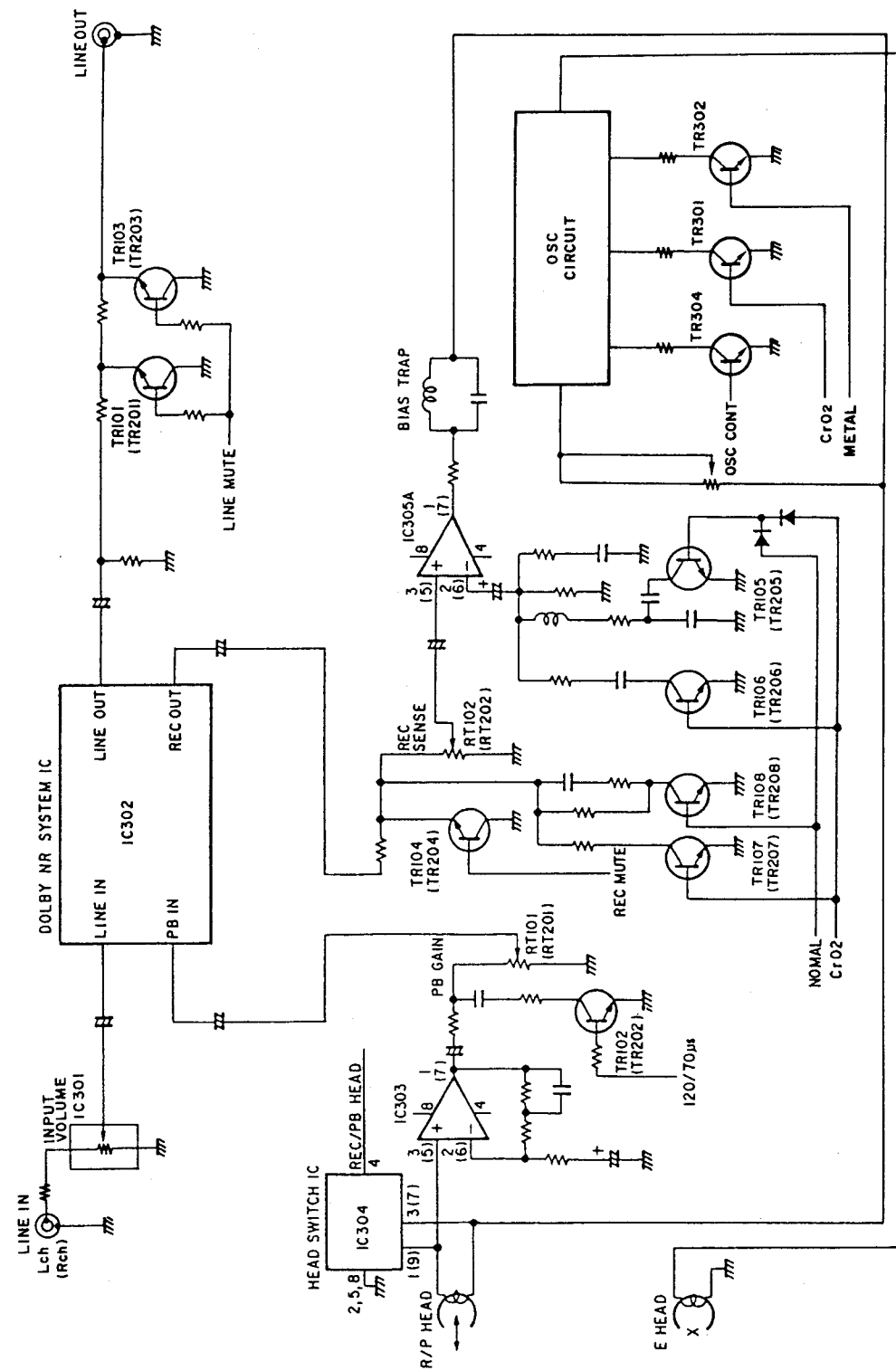

ADJUSTMENT

Adjustment and checking of the mechanism

1. Replacement of the pinch roller

Before replacing the pinch roller, clean the tape contact surface of the pinch roller and the tape contact surface of the capstan shaft. After replacement, run a C-90 tape without a pad and check for the presence of tape curl at the tape guide portion of the head.

2. Checking the pinch roller pressure

Set to the playback condition and hook a bar-type spring scale to the bracket above the center line of the pinch roller. Pull the pinch roller away from the capstan shaft, then allow the pinch roller to come into contact with the capstan shaft and check that the reading of the bar-type spring scale is between 250 g and 350 g when the pinch roller starts to rotate.

Replace the pinch roller when the value falls outside of the specified range.

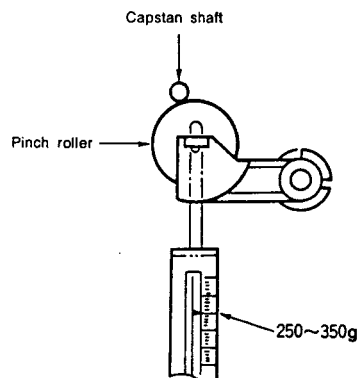

3. Replacement of the recording/playback head assembly

Perform this procedure after removing the front panel.

3-1 Removal of the head assembly

- (1) Remove the 2 head base fastening screws.
- (2) Remove the head base from the reed holder and the wire connector.

3-2 Mounting the recording/playback head assembly

Perform by following the steps of Section 3-1 Removal of the head assembly in reverse.

4. Adjustment of the recording/playback head

Azimuth adjustment

Load side A of the A-BEX TCC-153 test tape facing forward, and adjust.

- (1) Play in the FWD direction and turn the azimuth adjustment nut for the FWD side so that the Lissajous's figure becomes maximum at (A) and minimum at (B).
- (2) Play in the REV direction and turn the azimuth adjustment nut for the REV side, adjusting the same as in Step (1).
- (3) Repeat Steps (1) and (2), making the adjustments again.
- (4) Apply screw lock to the adjustment locations.

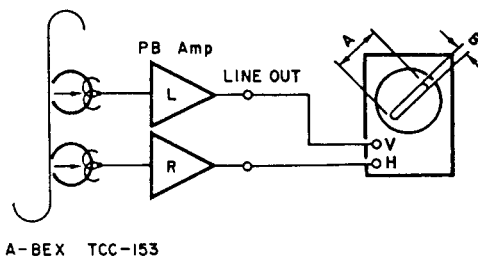

A-BEX TCC-153

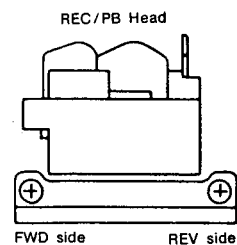

CASSETTE DECK SECTION

5. Checking the winding torque

Load a cassette type torque meter (Sony TW2111A at the FWD side, and Sony TW2121A at the REW side) and check that the reading of the torque meter during playback is 30 to 70 g-cm at the center value.

When outside of the specified value range, check the voltage of the reel motor (approx. 4 V). When the voltage value is low, the torque is weak, and when high, the torque is strong.

6. Checking the back tension torque at the time of recording and playback

Load a cassette type torque meter (Sony W2111A at the FWD side, and Sony TWG121A at the REW side) and check that the reading of the torque meter during playback is 2 to 6 g-cm and that there is no unevenness.

7. Checking the FF and REW torque

Load a cassette type torque meter (Sony TW2231) and check that the value indicated by the torque meter for winding and rewinding is between 90 and 180 g-cm.

8. Checking the FF and REW time

Load a DENON HD-X/60 cassette tape, and check that the time for FF and REW is between 80 and 110 seconds. When outside of the specified range, check Steps 5 and 6.

9. Checking the erroneous erasure prevention, and the metal and chrome switch operations

Check that the detection lever is operating the switch properly depending upon the presence or absence of a hole.

Electrical System Adjustments

● Measuring instruments needed for the adjustments

- (1) Low frequency oscillator
- (2) Variable resistance attenuator
- (3) Electronic voltmeter
- (4) Oscilloscope
- (5) Frequency counter
- (6) Adjustment screwdriver
- (7) 4-sided adjustment rod for trap coil adjustments
- (8) Test tapes
(Sony TY224)
(A-BEX TCC-153, TCC-130, TCC-262B/162B)
(DENON HDX/60)
- (9) Mirror cassette for the transport (A-BEX TCC-902)

● Adjustment precautions

- (1) Before adjustments, use gauze or a swab moistened with alcohol to wipe the surface of the heads, the capstan shaft, and the pinch roller.
- (2) Demagnetize the record/playback head and the erase head with a head eraser.
- (3) Completely demagnetize the driver to be used for the adjustments.
- (4) Unless otherwise specified, set the various operation controls as indicated below.

Input control: Maximum (clockwise)

Dolby NR switch: Off

1. Tape transport check

Load the mirror cassette for the transport, and illuminate the area around the fixed guide of the record/playback head with a lamp and observe. Check that the tape edge is not hitting the tape guide portion.

Note that the tape transport is the greatest factor affecting the performance of the cassette deck. Never move the inspection locations without good reason.

For information about replacement and adjustment of the record/playback head, see the section "Adjustment and checking of the mechanism."

CASSETTE DECK SECTION

2. Azimuth adjustment

- 2-1 After making the tape transport check, load the test tape (A-BEX TCC-153).
- 2-2 Play back the test tape and turn the azimuth adjustment nut so that the Lissajous's figure becomes maximum at (A) and minimum at (B) for both the FWD and REV sides.

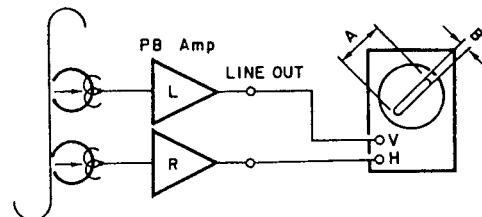

A-BEX TCC-153

REC/PB Head

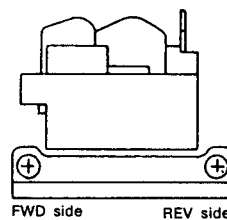

3. Tape speed check and adjustment

- 3-1 Connect the frequency counter to the LINE OUT pin and load the test tape (Sony TY-224).
- 3-2 Play back the test tape at an intermediate position of the tape for both the FWD and REW sides so that the transport is stable, and adjust the adjustment screw at the top surface of the capstan motor (Exploded View number 000) so that the reading of the frequency counter is set in a range of 3000 Hz \pm 15 Hz.

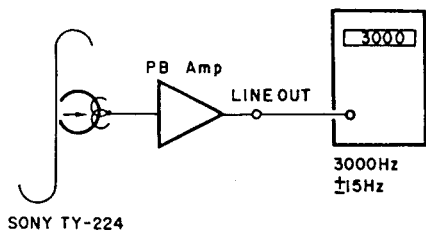

SONY TY-224

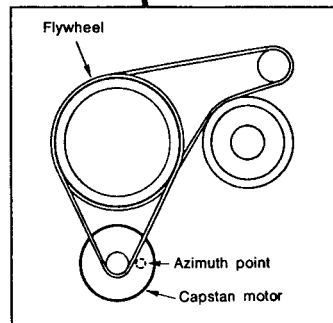
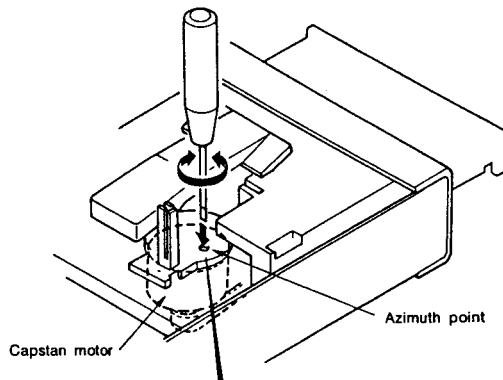

4. Adjustment of the playback system

- 4-1 Playback level
Play back the test tape for the Dolby standard level (A-BEX TCC-130), and adjust RT101 (left channel) and RT201 (right channel) so that the level of the LINE OUT pin becomes -2.0 dBm (620 mV). (Load resistance of 47 kohm)
- 4-2 Checking the playback frequency response
Play back the test tape (A-BEX TCC-262B/162B), and check that the frequency response satisfies the standard.

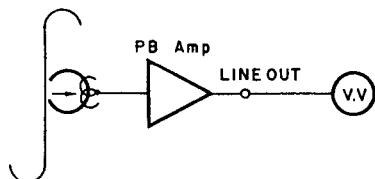

A-BEX TCC-262B/162B

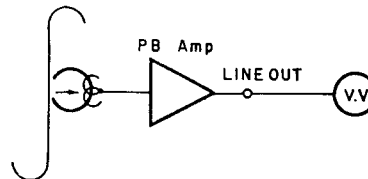

A-BEX TCC-130

NOTE:

After making the azimuth adjustment with the 8 kHz at the start of the A-BEX TCC-262B test tape, perform check of the frequency response. Also, after the check make an azimuth adjustment again with A-BEX TCC-153, then apply screw lock.

CASSETTE DECK SECTION

Playback Frequency Response

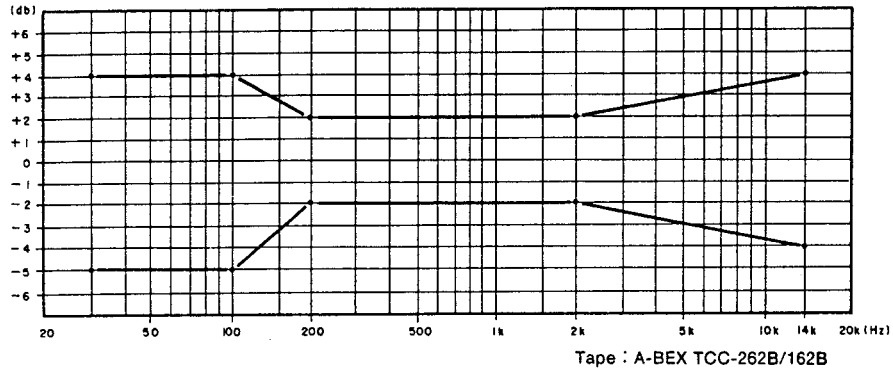

5. Adjustment of the recording system

5-1 Adjustment of the recording and playback overall frequency response

- (1) Load the DENON HDX / 60 test tape, record a signal of -20 dB 1 kHz input level, and play back.
- (2) Set the input signal to 10 kHz, record, and play back. Adjust RT103 (left channel) and RT203 (right channel) so that the response specifications of the diagram below are satisfied with respect to the 1 kHz output level.

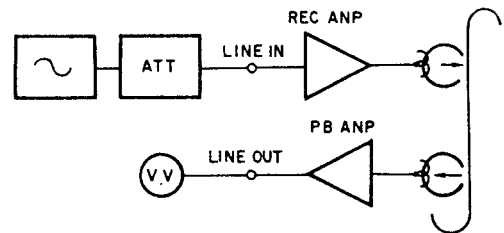

Recording / Playback Overall Frequency Response

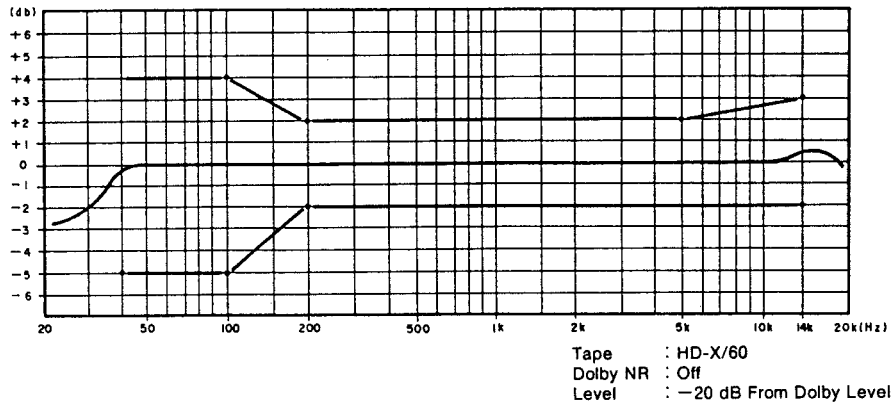

5-2 Adjustment of the recording/playback level

- (1) Load the DENON HDX / 60 test tape, record a signal of 1 kHz (-20 dB), and play back.
- (2) Adjust RT-102 (left channel) and RT-202 (right channel) so that the output of the LINE OUT pin becomes the same as the output at the time of the recording monitor.

5-3 Checking the Dolby C recording and playback overall frequency response

- (1) Set the Dolby NR switch to the "C" position.
- (2) Use the DENON HDX / 60 test tape to record and play back according to the outline of Section 5-1, then check that the response specifications have been satisfied.

Recording / Playback Overall Frequency Response

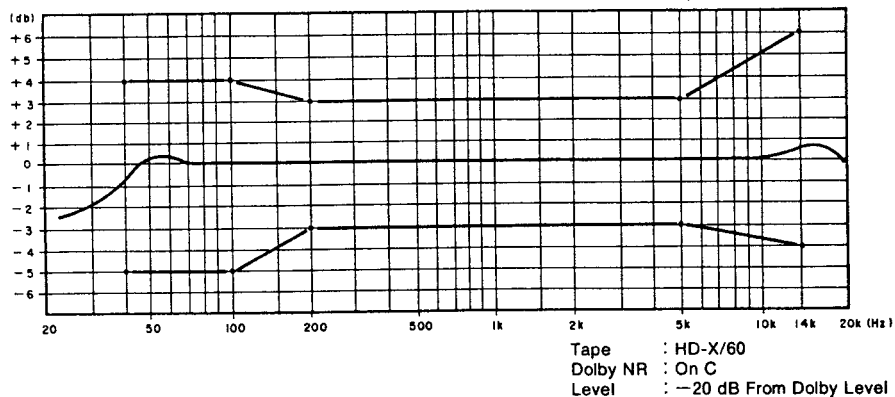

OUTLINE DIAGRAM OF ADJUSTMENT LOCATION

1U-2279A DECK UNIT (Component Side)

FRONT PANEL SIDE
←

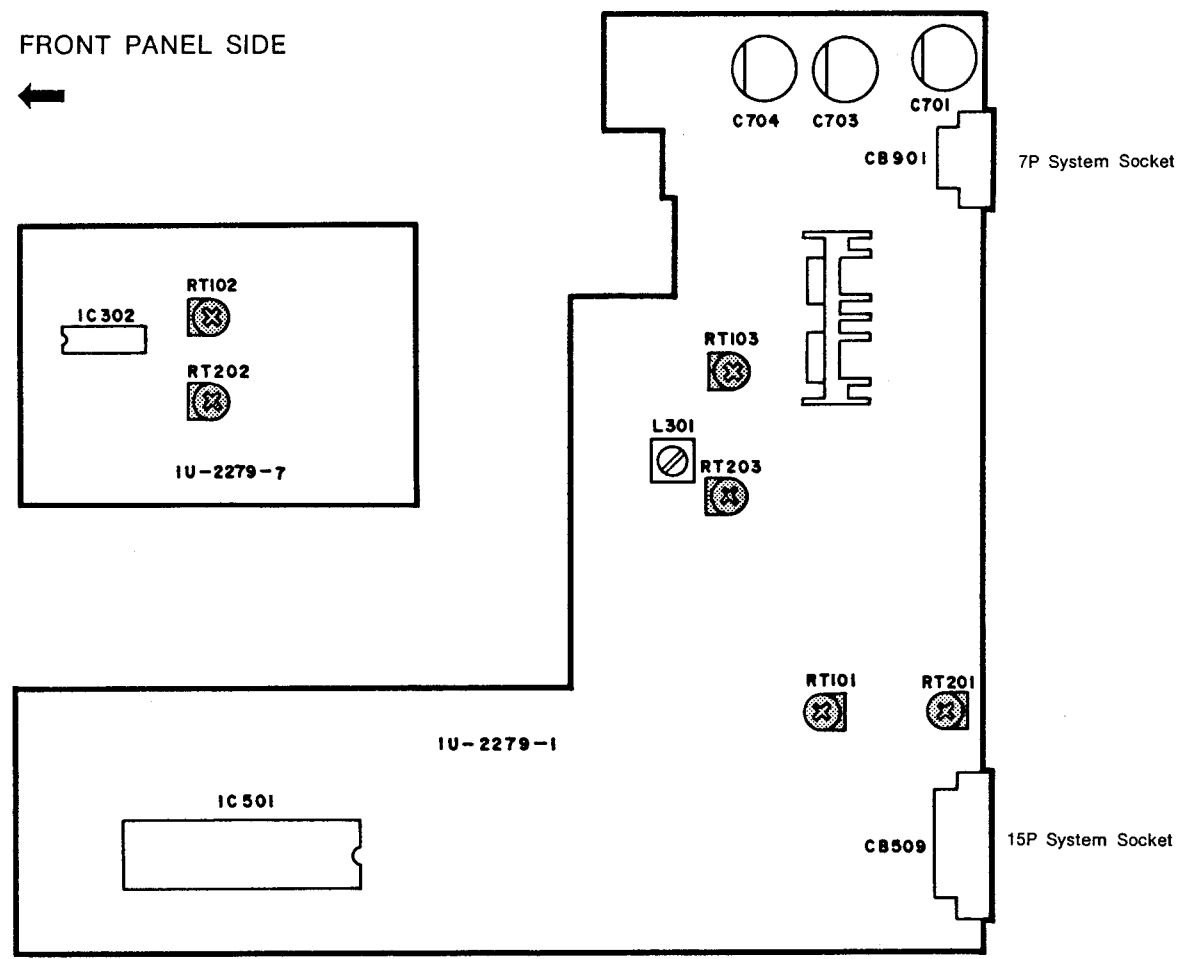

CASSETTE DECK SECTION

IC's

LC7583 (IC601)
LCD driver with level meter

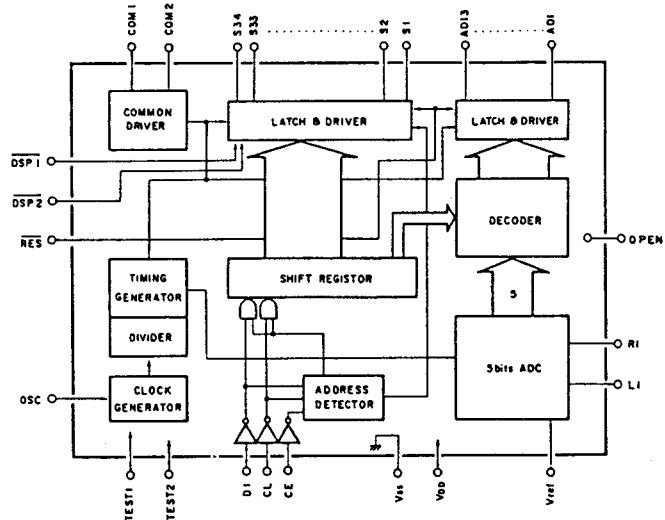
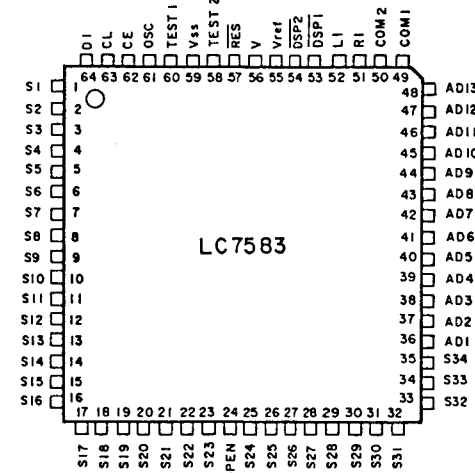
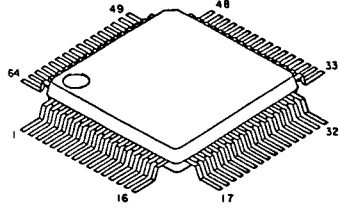

Pin Description

Pin	Pin No.	Description	Active	I/O
S1~S33	1~34	Segment outputs which display the data transferred from the serial data.	-	O
S34	35	Segment output which displays the external input (DSP1, DSP2) information.	-	O
AD1~AD13	36~48	Segment outputs which display the ADC input (R1, L1) information. Three kinds of patterns are output depending on the control bits "A1", and "A2". AD1 is the minimum lighting level, and AD13 is the maximum lighting level.	-	O
COM1	49	With the common driver output, the frame frequency is $\frac{f_{osc}}{512}$ Hz.	-	O
COM2	50			
R1	51	AD converter input pins.	Analog	I
L1	52			
DSP1	53	These are input pins for the direct (external input) display, and their segment output is output from S34.	L	I
DSP2	54			
Vref	55	Reference power supply pin of the AD converter.	-	-
VDD	56	Power supply pins.	-	-
VSS	59			
RES	57	This pin forcefully switches off the display in the initial condition.	L	I
TEST2	58	To be used in the open condition.	-	O
TEST1	60	To be used open or with Vss.	-	I
CE	62	Pins for serial data transfer. Connected with the controller. (microprocessor).	H	I
CL	63			
DI	64			
OPEN	24	No connection.	-	-

SEMICONDUCTORS

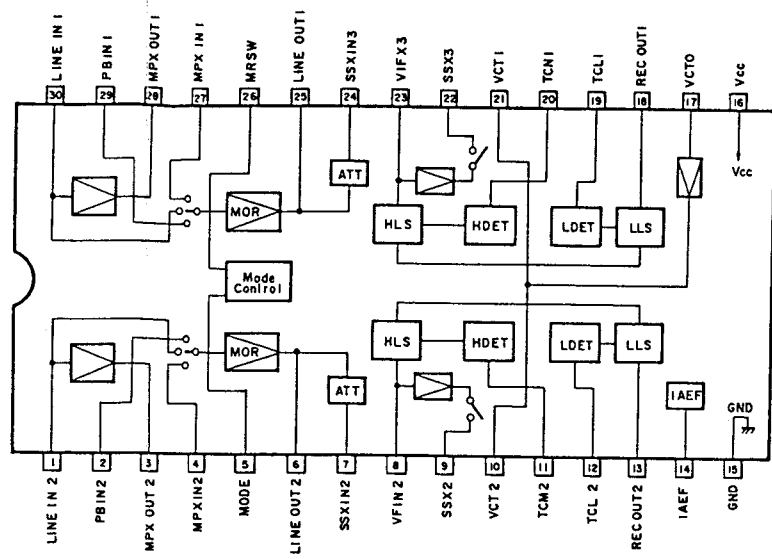
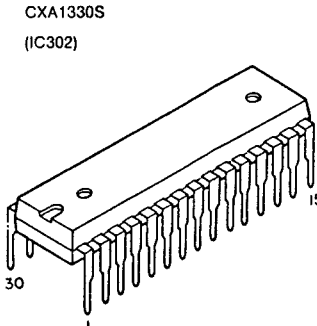

NJM78M06FA (IC901)
NJM78M08FA (IC902)
(Three-terminal positive constant voltage power supply)

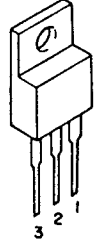

1: Output
2: GND
3: Input

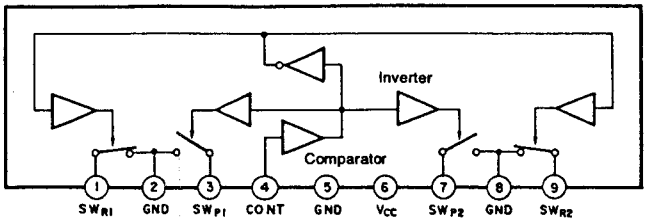
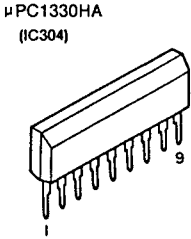

NJM79M08FA (IC903)
NJM79M12FA (IC904)
(Three-terminal negative constant voltage power supply)

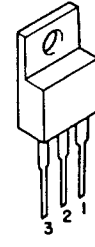

1: Output
2: Input
3: GND

M5218P (IC305)
M5220P (IC303)

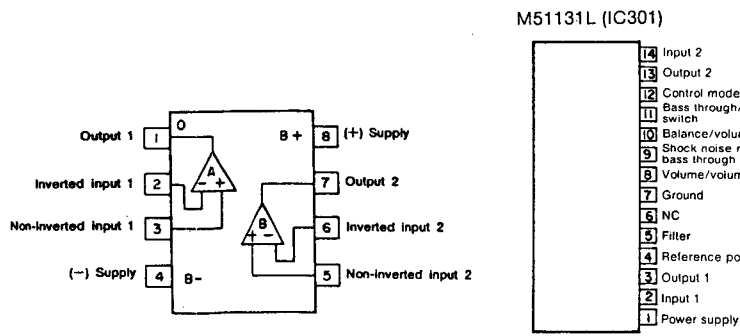
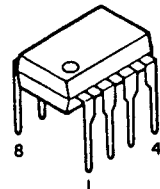

BA6238A Reversible motor driver (IC503) (2 circuits built in)

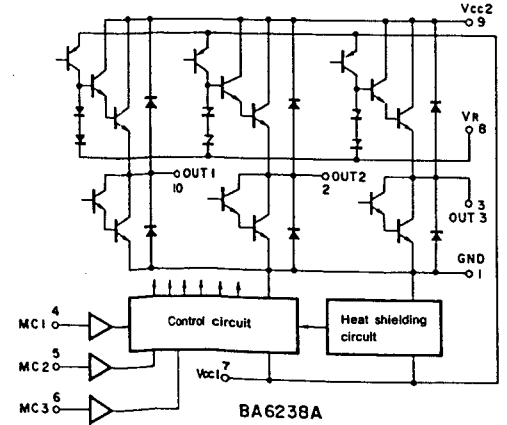
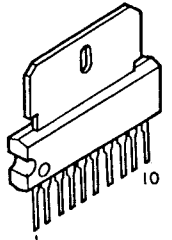

M51131L (IC301)

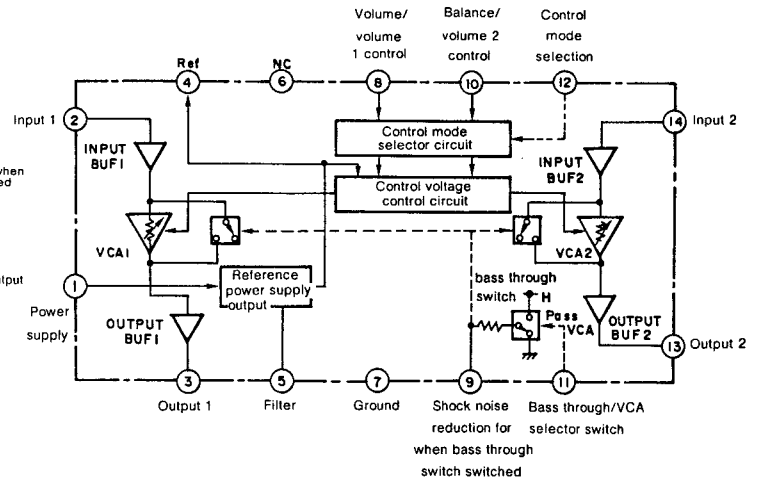
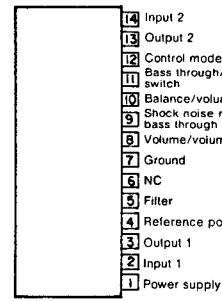

BA15218 (IC307, 308)

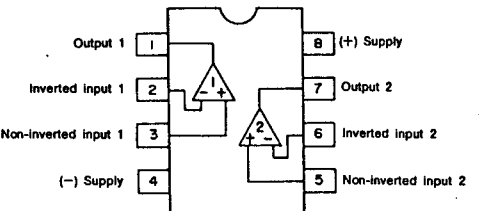
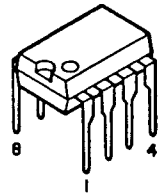

CASSETTE DECK SECTION

● Transistors

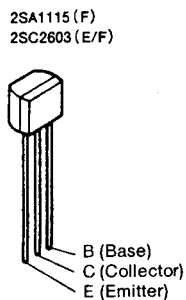
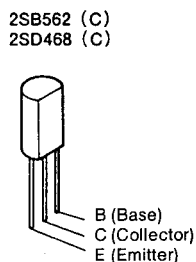
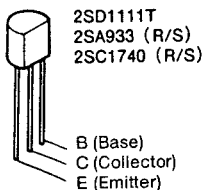

DTA114ES, 144ES... PNP Type
DTC114ES, 144ES... NPN Type

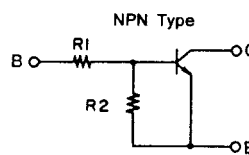
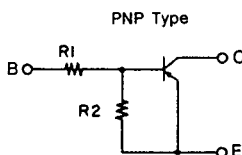
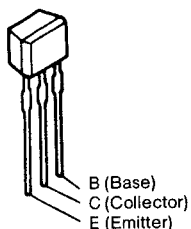

	R1	R2
DTA114ES	10k ohm	10k ohm
DTA144ES	47k ohm	47k ohm

	R1	R2
DTC114ES	10k ohm	10k ohm
DTC144ES	47k ohm	47k ohm
DTC114TS	10k ohm	-
DTC124XS	22k ohm	47k ohm
DTC323TS	2.2k ohm	-

DTC114TS } ...NPN Type
DTC124XS }

DTC323TS



(1) C/GND
(2) B/OUT
(3) A/IN

● LED Ass'y

Part No.: 3939493002 (LD601)

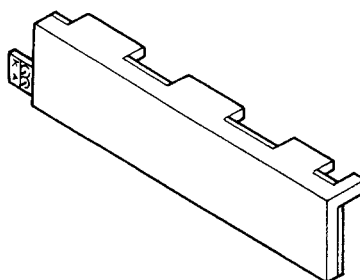

● Wiring Diagram

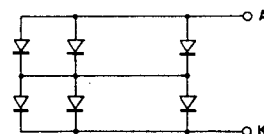

2 in series, 22 parallel = 44 chips

● Diodes (including LED)

1SS198

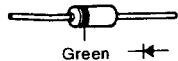

HZS2C-1 HZS6C-2
HZS4A-1 HZS7B-2
HZS4C-1

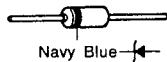

1SS270



1SR35-200A

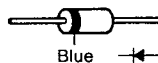

SLR-34VC3F (Red)
SLR-34MC3F (Green)

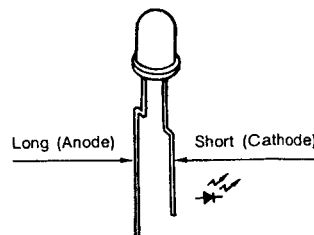

CASSETTE DECK SECTION

● LCD ASS'Y

Part No.: 3934114001

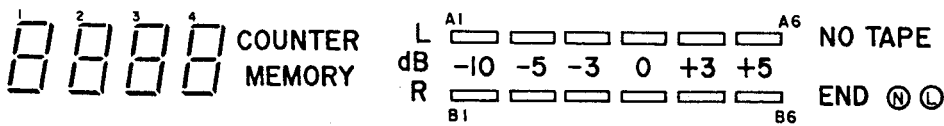
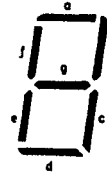
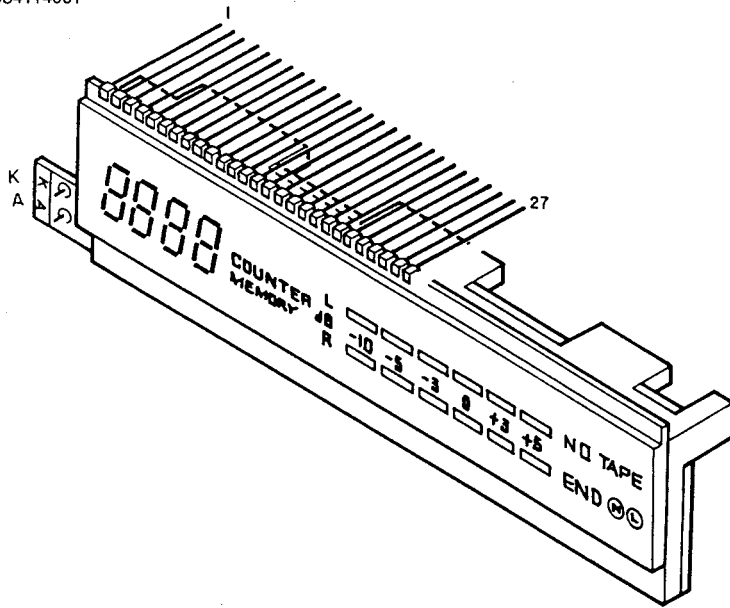

No.	1	2	3	4	5	6	7	8	9	10	11	12	13	14
COM1	COM	-	NO TAPE	Ⓝ	-	1e	1a	1b	1c	2f	2a	2c	3e	3a
COM2	-	COM	-	Ⓞ	END	1d	1f	1g	2e	2g	2b	2d	3d	3f

No.	15	16	17	18	19	20	21	22	23	24	25	26	27
COM1	3b	3c	4f	4a	4c	-	1)	A1	A2	A3	A4	A5	A6
COM2	3g	4e	4g	4b	4d	2)	-	B1	B2	B3	B4	B5	B6

1) L
dB -10 -5 -3 0 +3 +5
R

2) COUNTER
MEMORY

HD404019RB21S: 2621463105
(CMOS 4-bit single chip microprocessor)

- Major functions
 - Deck control
 - Deck mechanism control use and signal circuits, control output
 - Cuing operation, continuous playback
 - CD synchro operation
 - Auto function operation

CONTROL CIRCUIT

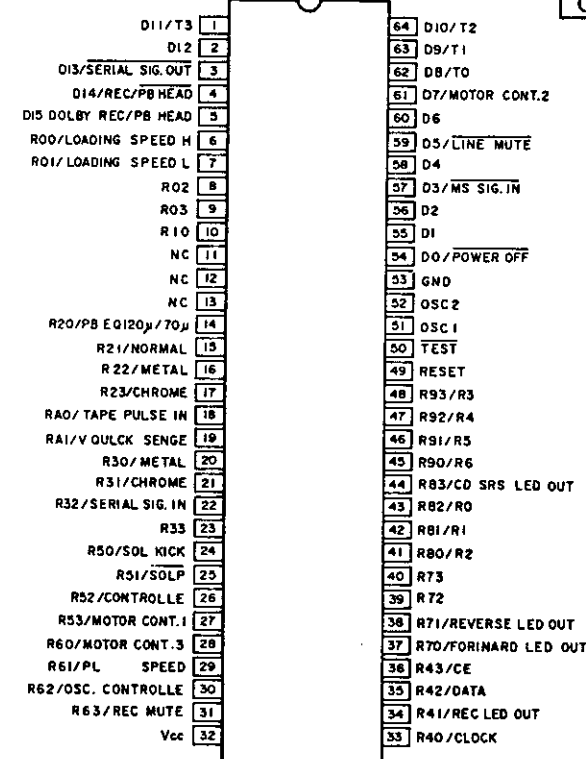

CASSETTE DECK SECTION

Pin Description

NO	Pin name	I/O	Signal name	Function
1	D11	O	T3	Strobe signal output pin for the key and switch matrix.
2	D12	I	-	-
3	D13	O	SERIAL SIG. OUT	Serial communications output pin.
4	D14	O	REC/PB HEAD	Output pin for switching the record/playback head. "H" is output for the record head.
5	D15	O	DOLBY REC/PB	Output pin for switching the mode of the Dolby IC (CXA1330s). "H" is output at time of recording and "L" is output at time of playback.
6	R00	O	LOADING SPEED H	Output pin which sets the speed of the loading motor high. "H" sets the loading speed high.
7	R01	O	LOADING SPEED L	Output pin which sets the speed of the loading motor low. "H" sets the loading speed low.
8	R02	O	NC	-
9	R03	O	NC	-
10	D10	O	NC	-
11	R11	O	NC	-
12	R12	O	NC	-
13	R13	O	NC	-
14	R20	O	PB EQ 120µ/70µ	Output pin which switches the 120µ/70µ time constant of the playback EQ. "L" is output at 120µ (NORMAL), and "H" is output at 70µ (CHROME, METAL).
15	R21	O	NORMAL	Pin which outputs "H" at the time of normal tape. ("L" for switch input of each of chrome and metal.)
16	R22	O	METAL	Pin which outputs "H" at the time of metal tape. ("H" for switch input of each of chrome and metal.)
17	R23	O	CHROME	Pin which outputs "H" at the time of chrome tape. ("H" for switch input of each of chrome and metal.)
18	RA0	O	TAPE PULSE IN	Input pin which takes in the reel pulse of the mechanism.
19	V	I	NC	-
20	R30	I	METAL	Input pin which takes in the metal mechanism switch. ("H" is input at the time of metal tape.)
21	R31	I	CHROME	Input pin which takes in the chrome mechanism switch. ("H" is input at the time of metal and chrome tape.)
22	R32/INT0	I	SERIAL SIG. IN	Input pin for serial communications.
23	R33/INT1	I	-	-
24	R50	O	SOL KICK	Output pin which drives the solenoid.
25	R51	O	SOL P	Output pin used to prevent overheating of the solenoid. Output "L" during play and cue/review, and controls the maintenance of the applied voltage.
26	R52	O	CPM CONTROL	Output pin which drives the capstan motor. Outputs "H" when the capstan motor is rotating.
27	R53	O	MOTOR CONT.1	Digit output pin 1 for the control of driver IC (BA6238) which is used for loading and the reel motor.
28	R60	O	MOTOR CONT.3	Digit output pin 3 for the control of driver IC (BA6238) which is used for loading and the reel motor.
29	R61	O	PLAY SPEED	Output pin which outputs "H" at time of play, and controls the speed of the reel motor.
30	R62	O	OSC. CONTROL	Output pin used to control the bias oscillator. Outputs "H" at the time of recording.
31	R63	O	REC MUTE	Output pin which controls the muting of the recording amplifier input. Outputs "H" at times other than recording.
32	Vcc	O	Vcc	Power supply input pin.
33	R40/SCK	O	CLOCK	Clock output pin for the LCD driver IC (LC7583).
34	R41/S1	O	REC LED OUT	REC LED drive pin. "H": lit "L": off
35	R42/S0	O	DATA	Data output pin for the LCD driver IC (LC7583).
36	R43	O	CE	Chip enable output pin for the LCD driver IC (LC7583).
37	R70	O	FORWARD LED OUT	FORWARD LED drive pin. "H": lit "L": off
38	R71	O	REVERSE LED OUT	REVERSE LED drive pin. "H": lit "L": off

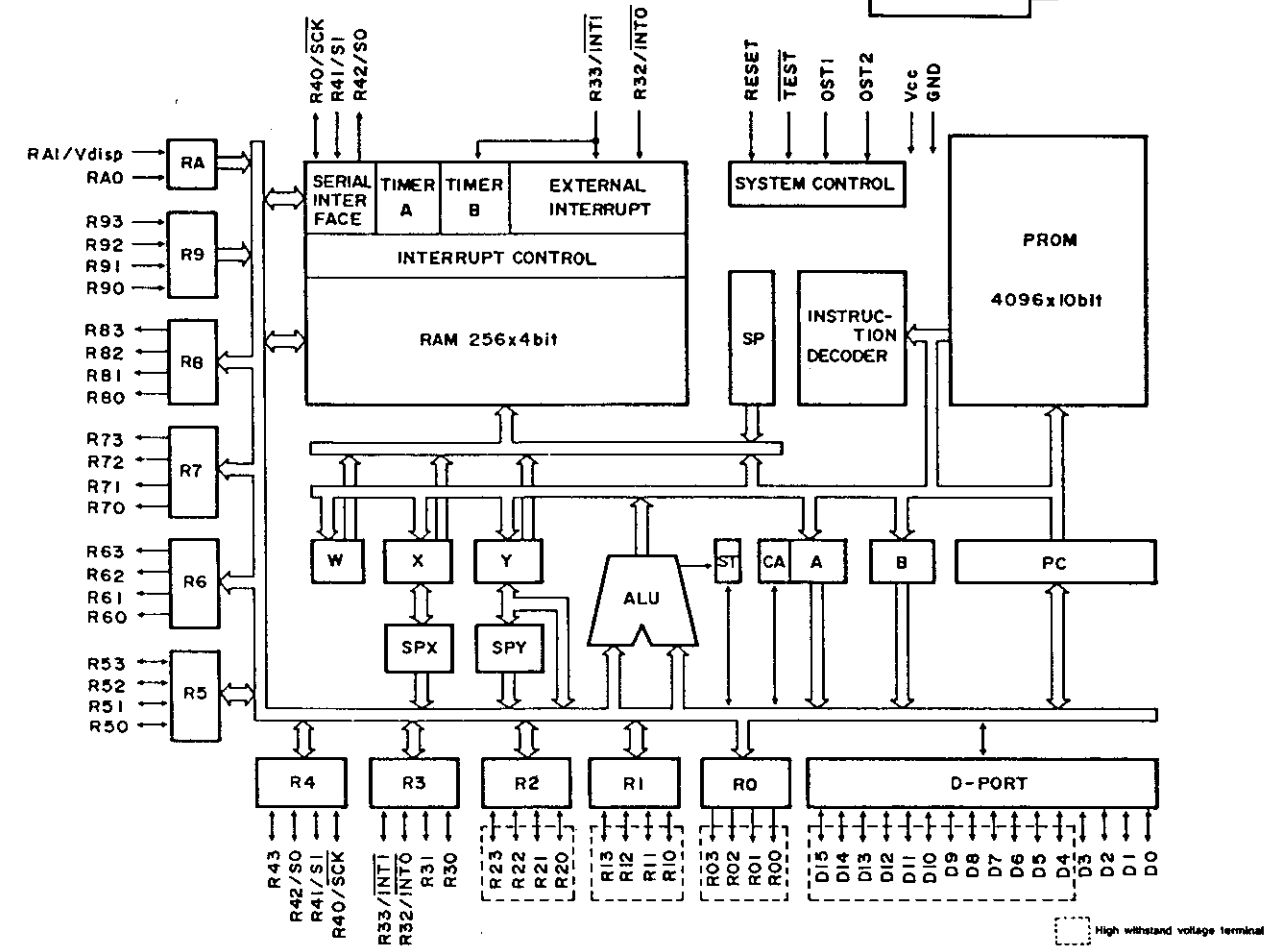

High withstand voltage terminal

CASSETTE DECK SECTION

NO	Pin name	I/O	Signal name	Function
39	R72	O	—	—
40	R73	O	—	—
41	R80	I	R2	Input take-in pin of keys and switches.
42	R81	I	R1	⋄
43	R82	I	R0	⋄
44	R83	O	NC	—
45	R90	I	R6	Input take-in pin of keys and switches.
46	R91		R5	Input take-in pin of keys and switches.
47	R92		R4	⋄
48	R93		R3	⋄
49	RESET		RESET	System reset input pin. (Active high)
50	TEST	I	TEST	Connected to Vcc.
51	OSC1	I	OSC1	Pin used for the system clock oscillation. (4 MHz)
52	OSC2	I	OSC2	⋄
53	GND	I	GND	Ground
54	D 0	I	NC	—
55	D 1	O	NC	—
56	D 2	O	NC	—
57	D 3	I	MS SIG. IN	Input pin of the between-track detection signal from the between-track detection IC.
58	D 4	O	—	—
59	D 5	O	LINE MUTE	Output pin used for muting of the audio signal output. Outputs "H" at the time of PLAY, REC, REC PAUSE, and REC MUTE, and "L" at other times.
60	D 6	I	—	—
61	D 7	O	MOTOR CONT.2	Digit output pin 2 for the control of driver IC (BA6238) which is used for loading and the reel motor.
62	D 8	O	T0	Strobe signal output pin for the key and switch matrix. (Active high)
63	D 9	O	T1	⋄
64	D10	O	T2	⋄

● Description of key inputs

Item	Key name	Functional description
1	F. PLAY	Specifies the PLAY mode of the FORWARD direction. PLAY+REW/FF corresponding to one-touch play, or specifies the CUE/REVIEW mode with FF/REW during the PLAY mode.
2	R. PLAY	Specifies the PLAY mode of the REVERSE direction. Transition of the CUE/REVIEW mode corresponding to one-touch play is the same as F. PLAY.
3	F. F	Specifies that the tape be wound quickly to the right.
4	REW	Specifies that the tape be wound quickly to the left.
5	STOP	Specifies the STOP mode. This key input provides transition to the STOP mode regardless of the current mode.
6	REC/REC MUTE	Specifies the REC, REC PAUSE, and the REC MUTE mode. Key input in the STOP mode results in a transition to the REC PAUSE mode. Key input in the REC PAUSE mode results in a transition to the REC MUTE mode. When switched on at the same time as PLAY, or when there is PLAY key input in the REC PAUSE mode, there will be transition to the REC mode. The record conditions are to be satisfied.
7	OPEN/CLOSE	Specifies the OPEN/CLOSE mode of the cassette tray. This key input provides cyclic switching of the OPEN/CLOSE mode. Toggle operation. When there is key input while the power is off, the power will be switched on and then there will be a transition to the OPEN mode.
8	COUNTER RESET	Resets the counter to "0000".
9	CD SRS	Specifies the CD SRS operation.

● Description of switch inputs

Item	Switch name	Function description
1	(↔) : REVERSE	Specifies the both sides record/playback mode.
2	(↔) : CONTINUOUS	Specifies the continuous playback mode. When this switch is input during the REC mode, there will be a transition to the both sides recording mode.
3	F. REC	Input from this switch leads to the judgment that recording in the forward direction is possible.
4	R. REC	Input from this switch leads to the judgment that recording in the reverse direction is possible.
5	PACK	Input from this switch leads to the judgment that there is a cassette loaded.
6	LOAD IN	Input from this switch leads to the judgment that the cassette tray CLOSE operation is completed.
7	LOAD OUT	Input from this switch leads to the judgment that the cassette tray OPEN operation is completed.
8	LOAD SPEED DOWN	Input from this switch leads to the specification of LOADING SPEED DOWN for the cassette tray.

CASSETTE DECK SECTION

MICROPROCESSOR PERIPHERAL WIRING DIAGRAM

1 2 3 4 5 6 7 8

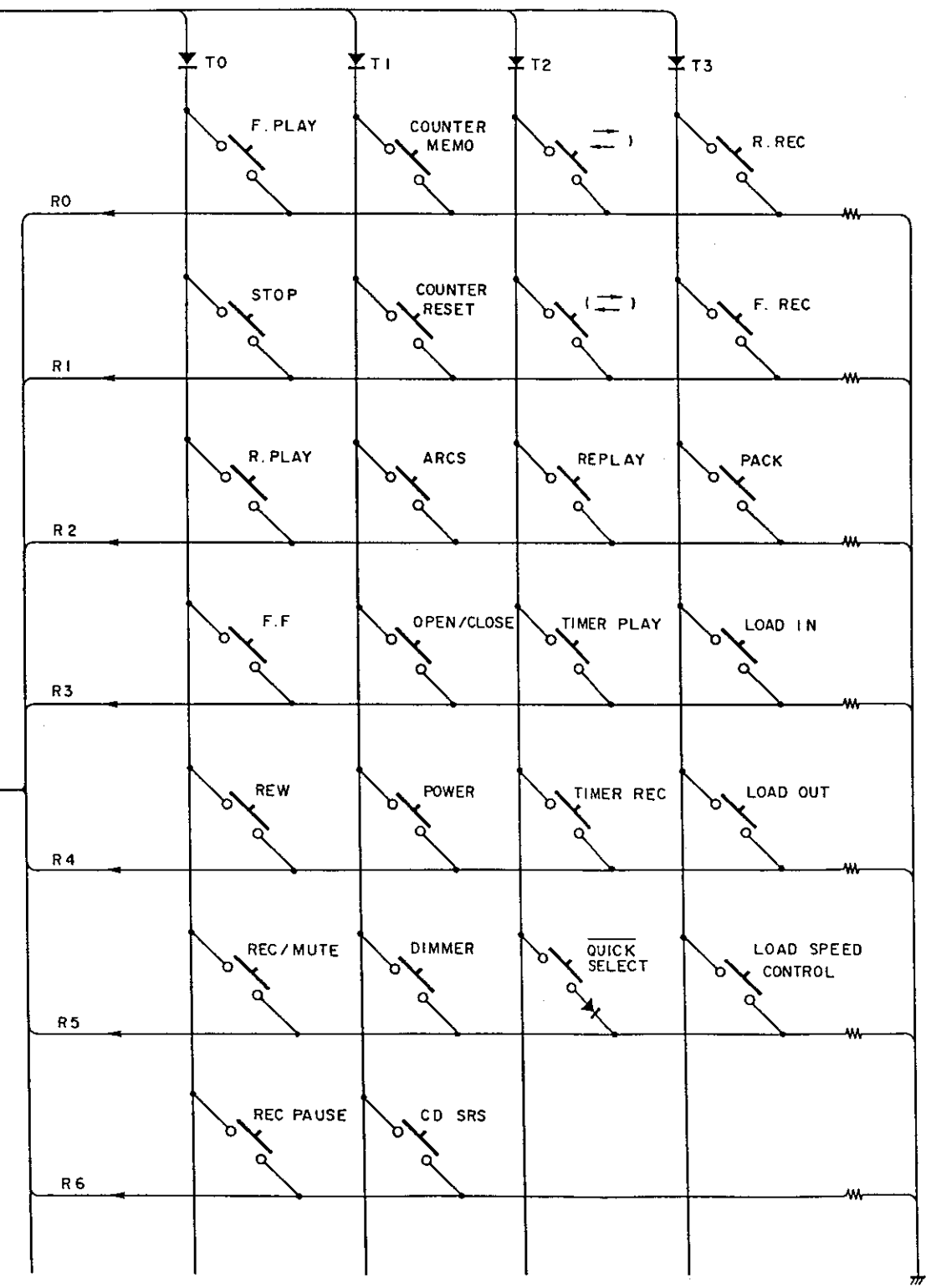
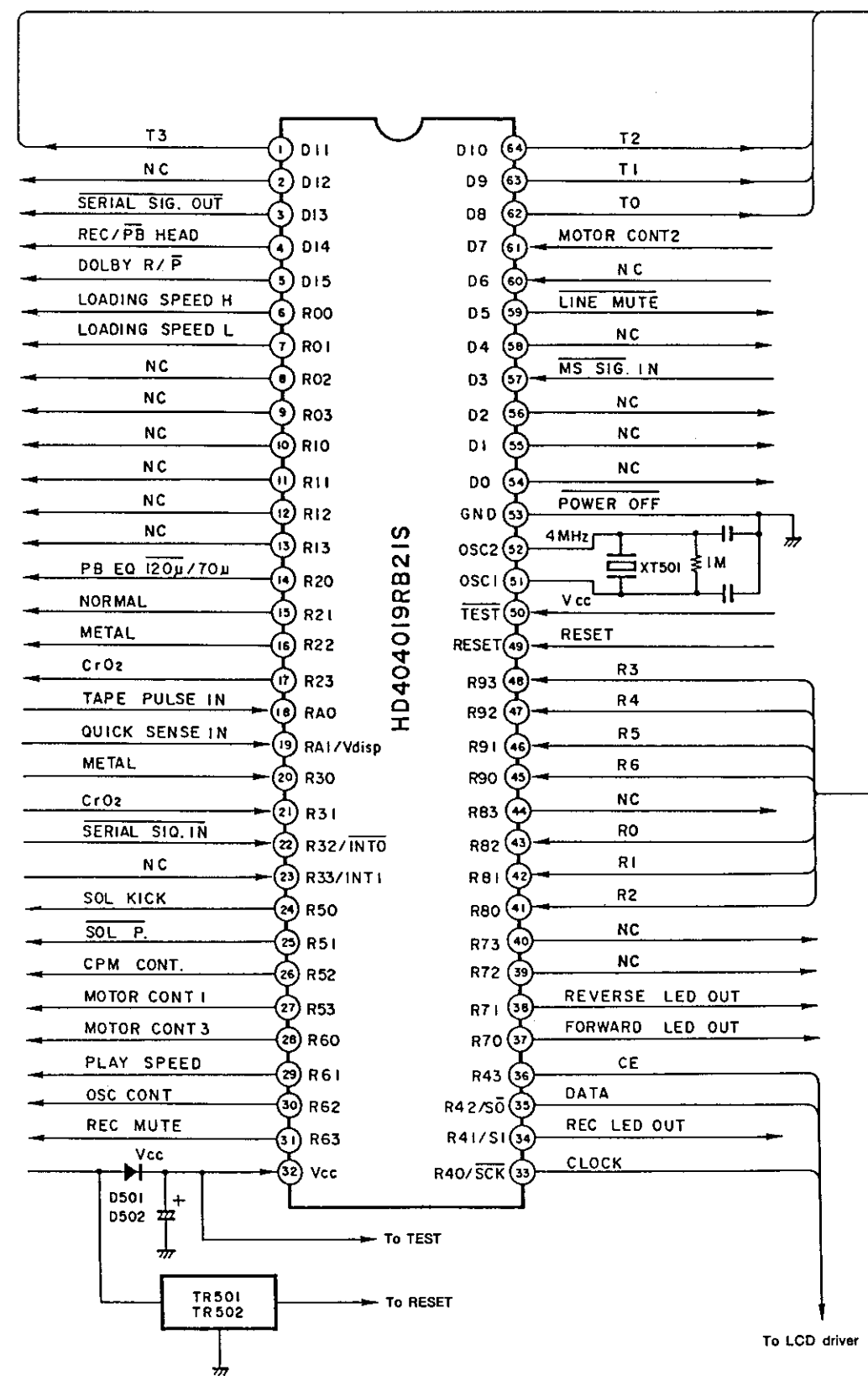

A
B
C
D
E

CASSETTE DECK SECTION

PRINTED WIRING BOARD

1U-2279A DECK UNIT ASS'Y

Component Side

A

B

C

D

E

1 2 3 4 5 6 7 8

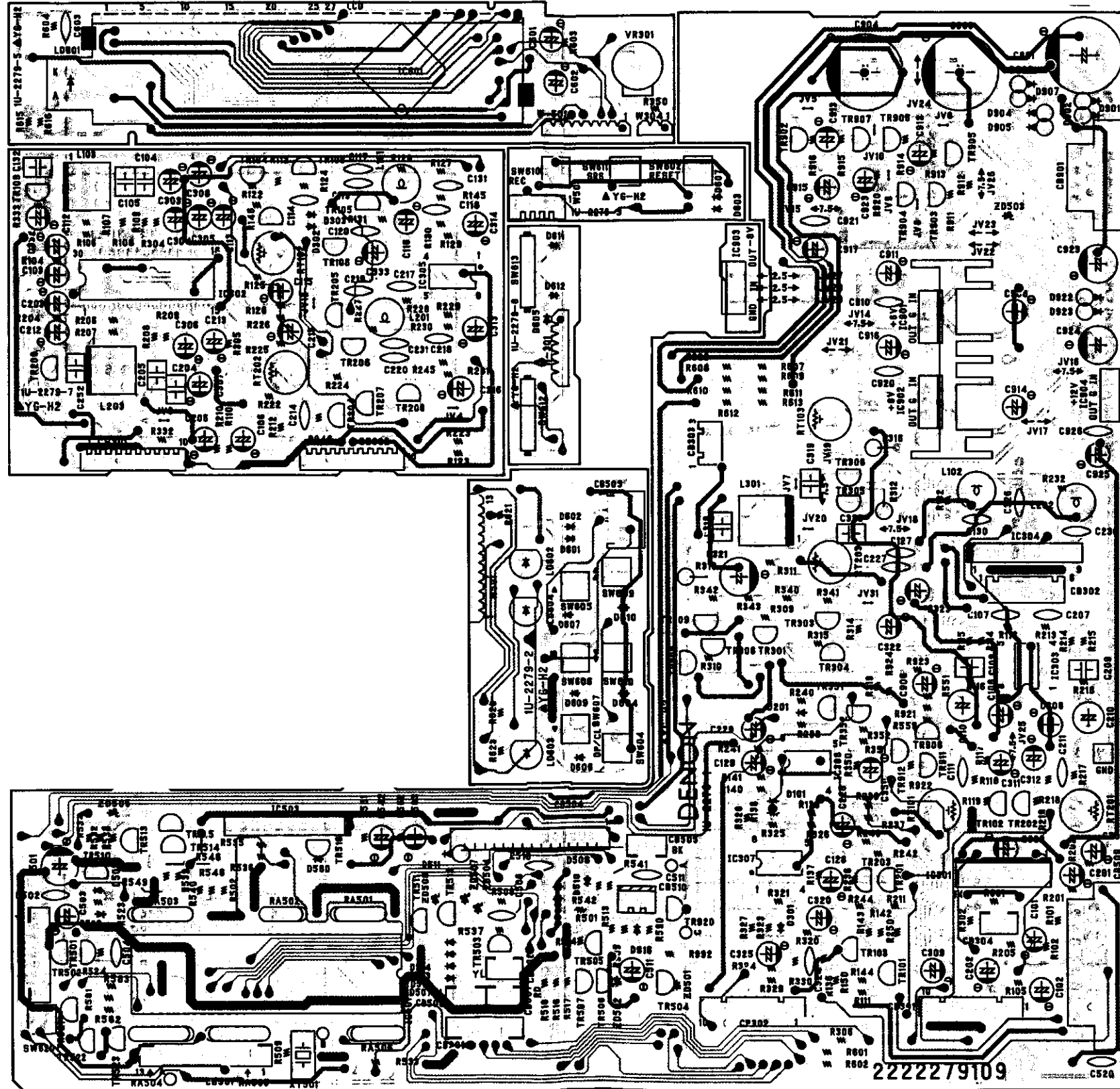

CASSETTE DECK SECTION

1 2 3 4 5 6 7 8

Pattern Side

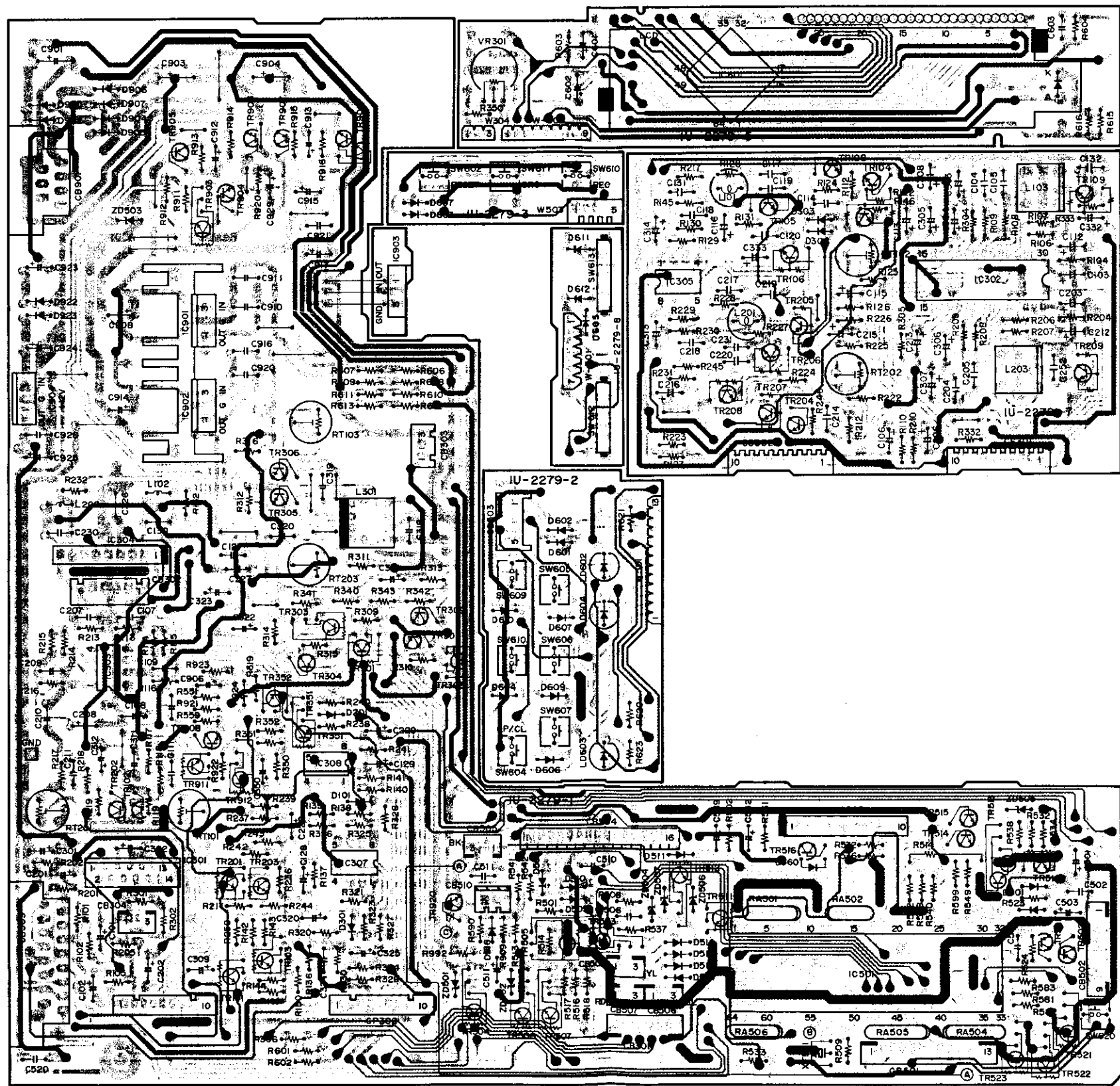

A

B

C

D

E

CASSETTE DECK SECTION

NOTES ON THE PARTS TABLE

NOTE FOR PARTS LIST

- Part indicated with the mark "⊙" are not always in stock and possibly to take a long period of time for supplying, or in some case supplying of part may be refused.
- When ordering of part, clearly indicate "1" and "I" (i) to avoid mis-supplying.
- Ordering part without stating its part number can not be supplied.
- Part indicated with the mark "★" is not illustrated in the exploded view.
- Not including Carbon Film ±5%, 1/6 W, 1/4W Type in the P. W. Board parts list.
- Parts marked with this symbol Δ have critical characteristics. Use ONLY replacement parts recommended by the manufacturer.
- Refer to the following table for the codes of the resistors and capacitors appearing on the parts list.

Resistors

Ex.: RN 14K 2E 182 G FR

Type	Shape and performance	Power	Resistance	Allowable error	Others
RD : Carbon	2B : 1/4W	F : ±1%	P : Pulse-resistant type		
RC : Fixed	2E : 1/2W	G : ±2%	NL : Low noise type		
RS : Metallic film	2H : 3/4W	J : ±5%	NB : Non-burning type		
RW : Winding	3A : 1W	K : ±10%	FR : Fuse resistor		
RN : Metal film	3D : 2W	M : ±20%	F : Lead wire forming		
RK : Metal mixture	3F : 3W				
	3H : 5W				

★ Resistance
 1 8 2 → 1800 ohm = 1.8 kohm
 ↳ Indicates number of zeros after effective number
 ↳ 2-digit effective number, decimal point indicated by R.
 • Units: ohm

Capacitors

Ex.: CE 04W 1H 2R2 M BP

Type	Shape and performance	Dielectric strength	Capacity	Allowable error	Others
CE : Aluminum foil electrolyte	DJ : 6.3V	F : ±1%	HS : High stability type		
CA : Aluminum solid electrolyte	1A : 10V	G : ±2%	BP : Non-polar type		
CS : Tantalum electrolyte	1C : 16V	J : ±5%	HR : Ripple-resistant type		
CO : Film	1E : 25V	K : ±10%	DL : For charge and discharge		
CK : Ceramic	1V : 35V	M : ±20%	HF : For assuring high frequency		
CC : Ceramic	1H : 50V	Z : +80%	U : UL part		
CP : Oil	2A : 100V	-20%	C : CSA part		
CM : Mica	2B : 125V	P : +100%	W : UL-CSA type		
CF : Metallized	2C : 160V	-0%	F : Lead wire forming		
CH : Metallized	2D : 200V	C : ±0.25pF			
	2E : 250V	D : ±0.5pF			
	2H : 500V	-			
	2J : 630V				

★ Capacity
 2 R 2 → 2.2 μF
 ↳ 1-digit effective number, decimal point indicated by R.
 ↳ 2-digit effective number, decimal point indicated by R.
 • Units: μF, (for P, pF (μμF))
 • When the dielectric strength is indicated in AC, "AC" is included after the dielectric strength value.

1U-2279A DECK UNIT PARTS LIST

Ref. No.	Part No.	Part Name	Remarks	Ref. No.	Part No.	Part Name	Remarks
SEMICONDUCTORS GROUP							
IC301	263 0761 005	IC M51131L		ZD506	276 0455 906	Zener Diode HZS4A-1	4V
IC302	263 0715 006	IC CXA1330S		ZD507	276 0451 900	Zener Diode HZS2C-1	2V
IC303	263 0317 006	IC M5220P		LD601	393 9493 002	LED Ass'y	LED
IC304	263 0590 001	IC μPC1330HA		LD602,603	393 9483 902	LED SLR-34MC70F120G	LED Green
IC305	263 0257 001	IC M5218P		LD604	393 9484 901	LED SLR-34VC70F120R	LED Red
IC307,308	263 0565 007	IC BA15218		LC601	393 4114 001	LCD Ass'y	LCD
IC501	262 1463 105	IC HD404019RB21S	μ-com	RESISTORS GROUP (Not included Carbon Film ±5% 1/4W Type. Refer to the Schematic Diagram for those Parts.)			
IC503	262 1362 002	IC BA6238A				Carbon Film 5% 1/4W	RD14B2E6R2JNBS
IC601	262 1363 001	IC LC7583				Fusable 10 ohm 1/4W	RD14B2E100FRS
IC901	263 0586 002	IC NJM78M06FA	Regulator			Fusable 10 ohm 1/4W	RD14B2E100FRS
IC902	263 0510 007	IC NJM78M08FA	Regulator			Metal Oxide Film 10 ohm 2W	RS14B3D100JNB
IC903	263 0511 006	IC NJM79M08FA	Regulator			Metal Oxide Film 50 ohm 2W	RS14B3D50JNBF
IC904	263 0571 004	IC NJM78M12FA	Regulator	VR301	211 0708 009	Variable Resistor 100k ohm	V09P08FB104
TR101,201	269 0072 909	Transistor DTC323TS	built in Resistor	RA501	246 2041 016	Resistor Array 10k ohmX5	RK99---103KP5
TR102,202	273 0178 925	Transistor 2SC1740 (R/S)		RA502	246 1073 000	Resistor Array 10k ohmX4	RK99---103JP4 (S)
TR103,203	269 0072 909	Transistor DTC323TS	built in Resistor	RA504,505	246 2073 013	Resistor Array 10k ohmX6	RK99---103JP6 (S)
TR104,204	273 0245 027	Transistor 2SC2603 (E/F)	built in Resistor	RA506	246 2041 016	Resistor Array 10k ohmX5	RK99---103KP5
TR105~108, 205~208	269 0074 907	Transistor DTC114TS (10k)	built in Resistor	RT101,201	211 6077 983	Semi Fixed Resistor 47k ohm	
TR109,209	269 0072 909	Transistor DTC323TS (R/S)	built in Resistor	RT102,202	211 6077 954	Semi Fixed Resistor 22k ohm	
TR301,302	269 0040 902	Transistor DTC144ES (47k-47k)	built in Resistor	RT103,203	211 6077 983	Semi Fixed Resistor 47k ohm	
TR303	271 0167 901	Transistor 2SA1115 (F)		CAPACITORS GROUP			
TR304	269 0040 902	Transistor DTC144ES (47k-47k)	built in Resistor	C101,201, 102,202	254 4258 002	Electrolytic 4.7 μF/35V	CE04W1V4R7M
TR305,306	273 0245 900	Transistor 2SC2603 (E/F)		C103,203	254 4260 058	Electrolytic 2.2 μF/50V	CE04W1H2R2M
TR308,309	271 0167 901	Transistor 2SA1115 (F)		C104,204, 105,205	255 1120 042	Film 0.0022 μF/50V	CQ93M1H222J
TR351	269 0040 902	Transistor DTC144ES (47k-47k)	built in Resistor	C106,206	254 4260 058	Electrolytic 2.2 μF/50V	CE04W1H2R2M
TR352	269 0093 904	Transistor DTA144ES (47k-47k)	built in Resistor	C107,207	253 3645 008	Ceramic 560pF/50V	CC45SL1H561J
TR501,502	271 0183 927	Transistor 2SA933 (R/S)		C108,208	254 4252 024	Electrolytic 47 μF/10V	CE04W1A470M
TR503~507	269 0040 902	Transistor DTC144ES (47k-47k)	built in Resistor	C109,209	255 1120 097	Film 0.0056 μF/50V	CQ93M1H562J
TR510~512	269 0015 908	Transistor DTC124XS (22k-47k)	built in Resistor	C110,210	254 3056 014	Electrolytic 1 μF/50V (Bipole)	CE04W1H010MBP
TR513	274 0111 008	Transistor 2SD1111		C111,211	253 9030 073	BC Ceramic 0.015 μF/25V	CK45-1E153K
TR514,515	274 0036 905	Transistor 2SD468 (C)		C112,212	254 4260 045	Electrolytic 1 μF/50V	CE04W1H010M
TR521~523	269 0015 908	Transistor DTC124XS (22k-47k)	built in Resistor	C113,213	254 4260 058	Electrolytic 2.2 μF/50V	CE04W1H2R2M
TR902	274 0111 008	Transistor 2SD1111		C114,214	253 9030 044	BC Ceramic 4700pF/25V	CK45-1E472K
TR903	269 0040 902	Transistor DTC144ES (47k-47k)	built in Resistor	C115,215	254 4258 002	Electrolytic 4.7 μF/35V	CE04W1V4R7M
TR904	273 0178 925	Transistor 2SC1740 (R/S)		C116,216	254 4252 024	Electrolytic 47 μF/10V	CE04W1A470M
TR905	272 0025 004	Transistor 2SB562 (C)		C117,217	253 9030 357	BC Ceramic 6800pF/25V	CK45-1E682K
TR906	273 0178 925	Transistor 2SC1740 (R/S)		C118,218	256 1034 063	Metalized 0.082 μF/50V	CF93A1H823J
TR907	271 0183 927	Transistor 2SA933 (R/S)		C119,219	253 9031 072	BC Ceramic 3900pF/25V	CK45-1E392K
TR908	273 0245 900	Transistor 2SC2603 (E/F)		C120,220	253 9030 015	BC Ceramic 1500pF/25V	CK45-1E152K
TR911	269 0020 906	Transistor DTC114ES (10k-10k)	built in Resistor	C127,227	253 1179 042	Ceramic 220pF/50V	CK45B1H221K (DD-3)
TR912	269 0046 906	Transistor DTA114ES (10k-10k)	built in Resistor	C128,228	254 4260 058	Electrolytic 2.2 μF/50V	CE04W1H2R2M
TR920	273 0179 925	Transistor 2SC1740 (R/S)		C129,229	254 4260 061	Electrolytic 3.3 μF/50V	CE04W1H3R3M
D101	276 0417 902	Diode 1SS270		C130,230	253 1179 026	Ceramic 150pF/50V	CK45B1H151K (DD-3)
D201	276 0417 902	Diode 1SS270		C131,231	253 9030 002	BC Ceramic 1000pF/25V	CK45-1E102K
D301~303	276 0417 902	Diode 1SS270		C132,232	255 1120 055	Film 0.0027 μF/50V	CQ93M1H272J
D501,502	276 0417 902	Diode 1SS270		C301	254 4254 006	Electrolytic 10 μF/16V	CE04W1C100M
D507	276 0503 900	Diode 1SS198		C302	254 4254 019	Electrolytic 22 μF/16V	CE04W1C220M
D508~510	276 0417 902	Diode 1SS270		C303	254 4278 040	Electrolytic 0.56 μF/50V	CE04W1HR56M
D511	276 0553 905	Diode 1SR35-200A		C304	254 4260 029	Electrolytic 0.33 μF/50V	CE04W1HR33M
D512~514	276 0417 902	Diode 1SS270		C305	254 4254 006	Electrolytic 10 μF/16V	CE04W1C100M
D601,602	276 0503 900	Diode 1SS198		C306	254 4278 040	Electrolytic 0.56 μF/50V	CE04W1HR56M
D603,604	276 0417 902	Diode 1SS270		C307	254 4260 029	Electrolytic 0.33 μF/50V	CE04W1HR33M
D605	276 0503 900	Diode 1SS198		C308	254 4254 006	Electrolytic 10 μF/16V	CE04W1C100M
D606~612	276 0417 902	Diode 1SS270		C309	254 4256 017	Electrolytic 22 μF/50V	CE04W1E220M
D901,902	276 0553 905	Diode 1SR35-200A		C311~314	254 4254 006	Electrolytic 10 μF/16V	CE04W1C100M
D904~907	276 0550 908	Diode 1SR35-200A		C318	255 4079 048	Film 0.01 μF/100V	CQ93P2A103J
D916	276 0417 902	Diode 1SS270		C319	255 1121 007	Film 0.022 μF/50V	CQ93M1H223J
D922,923	276 0553 905	Diode 1SR35-200A		C320	254 4254 006	Electrolytic 10 μF/16V	CE04W1C100M
ZD501~503	276 0463 914	Zener Diode HZS6C-2	6V	C321	254 4256 059	Electrolytic 220 μF/25V	CE04W1E221M
ZD504	276 0465 912	Zener Diode HZS7B-2	7V	C322	254 4254 006	Electrolytic 10 μF/16V	CE04W1C100M
ZD505	276 0457 904	Zener Diode HZS4C-1	4V	C323	254 4254 048	Electrolytic 100 μF/16V	CE04W1C101M
				C324	253 9030 031	BC Ceramic 3300pF/25V	CK45-1E332K

CASSETTE DECK SECTION

Ref. No.	Part No.	Part Name	Remarks	Qty
C325	254 4252 008	Electrolytic 22 μ F/10V	CE04W1A220M	
C326	253 1181 001	Ceramic 0.01 μ F/50V	CK45F1H103Z (DD-3)	
C332	254 4254 006	Electrolytic 10 μ F/16V	CE04W1C100M	
C333	254 4260 045	Electrolytic 10 μ F/50V	CE04W1H010M	
C501	254 4252 037	Electrolytic 100 μ F/10V	CE04W1A101M	
C502	253 1181 001	Ceramic 0.01 μ F/50V	CK45F1H103Z (DD-3)	
C503	254 4260 032	Electrolytic 0.47 μ F/50V	CE04W1HR47M	
C504	253 9036 006	BC Ceramic 0.1 μ F/25V	CK45-1E104K	
C506	253 1181 001	Ceramic 0.01 μ F/50V	CK45F1H103Z (DD-3)	
C510,511	253 9030 086	BC Ceramic 0.022 μ F/25V	CK45-1E223K	
C511	254 4256 017	Electrolytic 22 μ F/25V	CE04W1E220M	
C520	253 9036 006	BC Ceramic 0.1 μ F/25V	CK45-1E104Z	
C601	254 4305 065	Electrolytic 1 μ F/50V	CE04W1H010M (SRE)	
C602	254 4299 003	Electrolytic 10 μ F/16V	CE04W1C100M (SRE)	
C603	253 9030 002	BC Ceramic 1000pF/25V	CK45-1E102K	
C901	254 4257 003	Electrolytic 3300 μ F/25V	CE04W1E332MC	
C903	254 4256 091	Electrolytic 2200 μ F/25V	CE04W1E222MC	
C904	254 4257 003	Electrolytic 3300 μ F/25V	CE04W1E332MC	
C906	254 4256 059	Electrolytic 220 μ F/25V	CE04W1E221M	
C908	254 4256 004	Electrolytic 10 μ F/25V	CE04W1E100M	
C910	253 9031 014	BC Ceramic 0.068 μ F/25V	CK45-1E683K	
C911	254 4254 006	Electrolytic 10 μ F/16V	CE04W1C100M	
C912,913	254 4260 032	Electrolytic 0.47 μ F/50V	CE04W1HR47M	
C914,915	254 4256 004	Electrolytic 10 μ F/25V	CE04W1E100M	
C916,917	254 4254 006	Electrolytic 10 μ F/16V	CE04W1C100M	
C920,921	253 9031 014	BC Ceramic 0.068 μ F/25V	CK45-1E683K	
C923	254 4254 006	Electrolytic 10 μ F/16V	CE04W1C100M	
C923,924	254 4258 057	Electrolytic 100 μ F/35V	CE04W1V101M	
C925	254 4254 006	Electrolytic 10 μ F/16V	CE04W1C100M	
C926	253 9031 014	BC Ceramic 0.068 μ F/25V	CK45-1E683K	
C927	253 9036 006	BC Ceramic 0.1 μ F/25V	CK45-1E104Z	
OTHERS PARTS GROUP				Qty
L101,201	235 0020 916	(P.W. Board) Inductor 822J		(1) 2
L102,103	235 0020 945	Inductor 153J		2
	212 5606 905	Tact Switch		10
L103,203	232 0109 003	MPX Filter		2
L301	232 0164 006	105kHz OSC Coil		1
SW612	212 1046 006	Slide Switch (2-3)		1
SW613	212 1047 005	Slide Switch (1-3)		1
XT501	399 9018 003	Ceramic Vibrator	CST4.00MGW	1
	441 9038 009	LCD Holder		1
	447 0373 011	Heat Sink		1
	470 0012 022	Fan Screw 3X12 Washer With Washer Spring		2
CB301	205 0343 074	7P Connector Base (KR-PH)		1
CB302	205 0206 069	6P XH Connector Base		1
CB303	205 0206 030	3P XH Connector Base		1
CB304	205 0343 032	3P Connector Base (KR-PH)		1
CB501	205 0375 039	13P Connector Base (KR-PH)		1
CB502	205 0343 090	9P Connector Base (KR-PH)		1
CB503	205 0355 059	5P KR Connector Base (L)		1
CB901	204 2429 003	7P System Socket		1
CB509	204 8284 022	15P System Socket		1
CB504	205 0633 069	16P Trap Connector Base		1
CB505	205 0323 036	3P Connector Base (BLK)	Black	1
CB506	205 0322 037	3P Connector Base (BLUE)	Blue	1
CB507	205 0321 038	3P Connector Base (RED)	Red	1
CB508	205 0543 036	3P Connector Base (YEL)	Yellow	1
CS301,302	205 0536 056	10P Connector Socket		2
CP301,302	205 0535 057	10P Connector Base		1
W301	204 2452 025	7P KR-DA Connector Cord		1
W502	204 2269 014	9P KR-DA Connector Cord		1
W501	204 6269 023	13P KR-DA Connector Cord		1
W304	203 4591 020	3P KR-DA Connector Cord		1
W503	203 8017 018	5P KR-DS Connector Cord		1
W001	203 0319 044	1P St Connector Ass'y		1

CASSETTE DECK SECTION

WIRING DIAGRAM

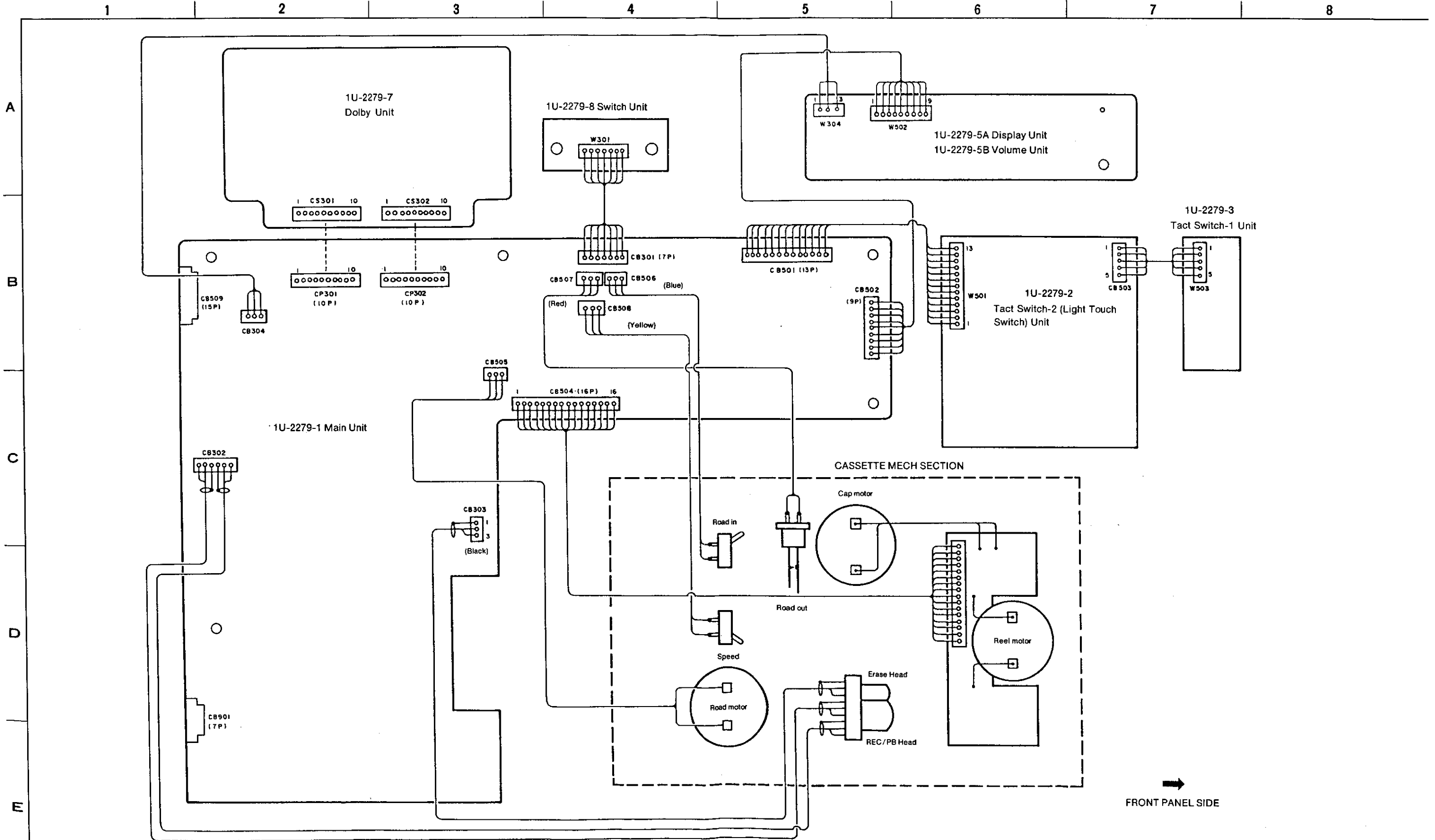

FRONT PANEL SIDE

SCHMATIC DIAGRAM

2

3

4

5

6

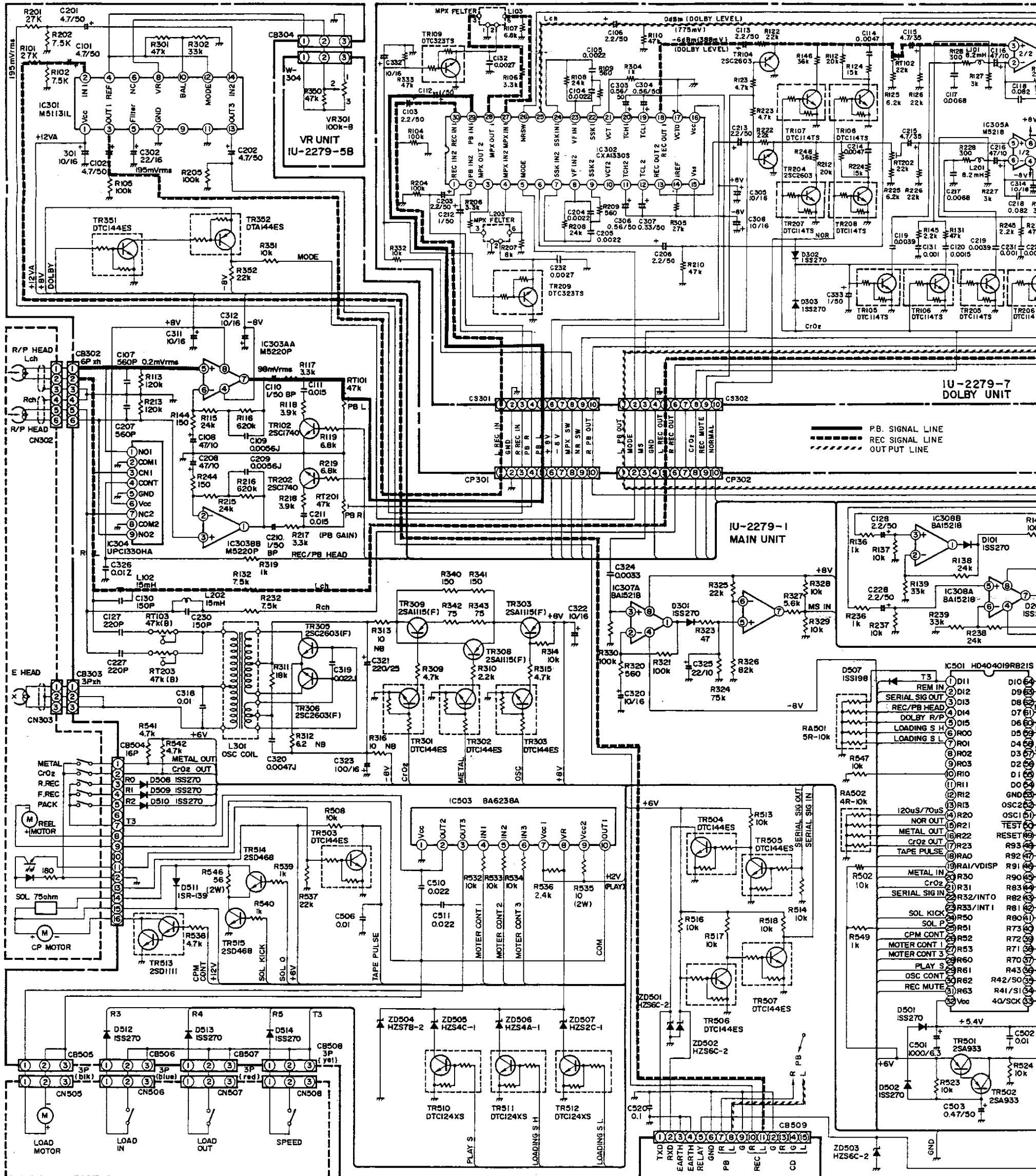

SYSTEM CONNECTOR 1

CASSETTE DECK SECTION

SCHEMATIC DIAGRAM

5 6 7 8 9 10

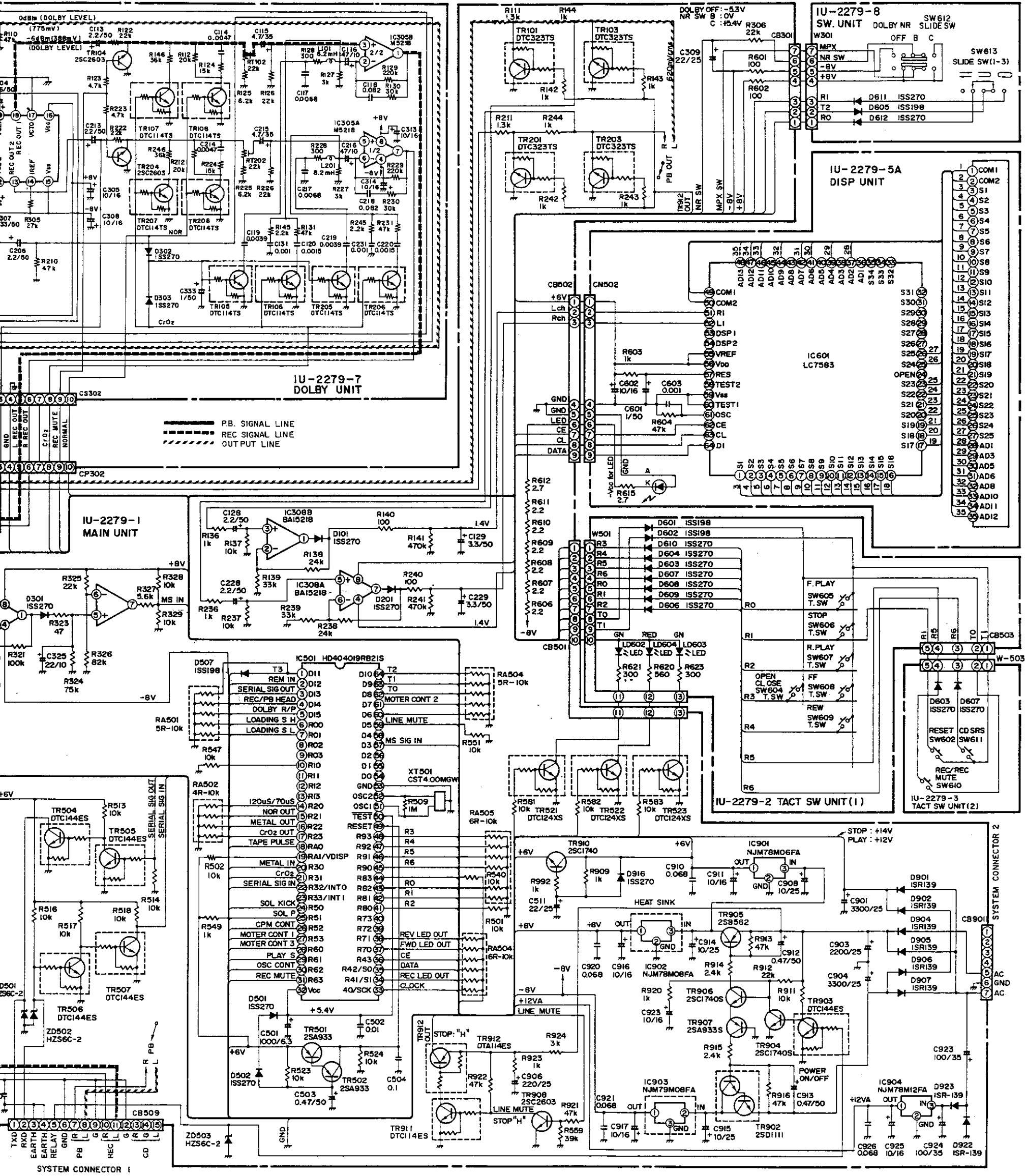

NOTES
 ALL RESISTANCE VALUES IN OHM K=1,000 OHM M=1,000,000 OHM EACH VOLTAGE AND CURRENT ARE MEASURED AT NO SIGNAL INPUT CONDITION.
 ALL CAPACITANCE VALUES IN MICRO FARAD P=MICRO-MICRO FARAD CIRCUIT AND PARTS ARE SUBJECT TO CHANGE WITHOUT PRIOR NOTICE.

A
B
C
D
E
F
G

CASSETTE DECK SECTION

EXPLODED VIEW OF PARTS LIST

Ref. No.	Part No.	Part Name	Remarks	Qty
● 1	411 1099 100	Chassis		1
2	105 0972 336	Rear Panel		1
3	104 0253 007	Foot Ass'y		4
4	415 9016 019	P.C.B Holder		2
★ 5	445 0033 005	Wire Clamp Band		6
● 6	1U- 2279 A	Deck Unit Ass'y		1 ^S
6-1	—	Main Unit		(1)
6-2	—	Tact Switch (2) Unit		(1)
6-3	—	Tact Switch (1) Unit		(1)
6-4	—	LCD Unit		(1)
6-5	—	Display, volume Unit		(1)
6-6	—	—		—
6-7	—	Dolby Unit		(1)
6-8	—	Switch Unit		(1)
7	254 4257 702	Chemicon 3300 μ/25V	C901.904	2
8	254 4256 790	Chemicon 2200 μ/25V	C903	1
9	212 1046 006	Slide Switch (2-3)	SW612	1
10	212 1047 005	Slide Switch (1-3)	SW613	1
11	393 4114 001	LCD Ass'y		1
12	211 0708 009	Variable Resistor 100k ohm	VR301	1
13	103 1470 103	Mech. Holder (B)		1
● 14	HM101	Cassette Mech Unit		1
15	146 1292 210	Loader Panel (D) Ass'y		1
● 16	144 2134 025	Front Panel		1
● 17	103 1471 322	Inner Panel Ass'y		1
18	435 0113 009	Latch (Y3Y18)		1
19	143 0743 101	Lens		1
20	113 1458 106	Control Button		1
21	113 9050 124	Select Button		2
22	112 0689 106	Rec Level Knob		1
23	144 2133 107	Trap Door		1
● 24	401 0126 200	Door Hinge (L)		1
● 25	401 0127 209	Door Hinge (R)		1
● 26	445 0048 003	Cord Holder (L-76)		1
● 27	146 1279 107	Side Panel (L) Ass'y		1
● 28	146 1281 108	Side Panel (R) Ass'y		1
● 29	102 0478 103	Top Cover		1
30	122 0146 057	Himeron Sheet	T0.5X10X15 Put on D. Unit	1
31	513 1642 002	No. Sheet		1
32	204 2429 003	7P System Socket		1
33	204 8284 022	15P System Socket		1
34	461 0577 055	Rubber Sheet	T10X15X25	1
★ 35	513 1863 014	Rating Sheet		1
36	122 0146 002	Himeron Sheet	Put on F/Panel	1
37	441 9038 009	LCD Holder		1
★ 38	461 9012 029	Cushion		1
★ 39	415 0615 008	Insulating Sheet		1
SCREWS				
71	473 7002 034	Tapping Screw (S) 3X6	Black	10
72	473 7500 015	Tapping Screw (P) 3X8	Black	9
73	473 7007 000	Tapping Screw (S) 4X8	Black	4
74	473 7002 021	Tapping Screw (S) 3X8	Black	11
75	473 7501 001	Tapping Screw (P) 3X10	Black	1
76	473 7500 044	Tapping Screw (P) 3X8	Black	2
77	473 7015 018	Tapping Screw (S) 3X8	Black	1
78	425 0232 006	Adjust Washer	t0.3 Black	2
79	425 0232 019	Adjust Washer	t0.5 Clear	2
PACKING & ACCESSORIES (Not included EXPLODED VIEW)				
● 101	505 0154 082	Cabinet Cover	600X600	1
● 102	—	—		—
● 103	503 9216 103	Cushion		2
● 104	501 1560 000	Sleeve Carton		1
● 105	513 1389 006	Control Card Base		1
● 106	513 1349 004	Thermal Carbon Film		1

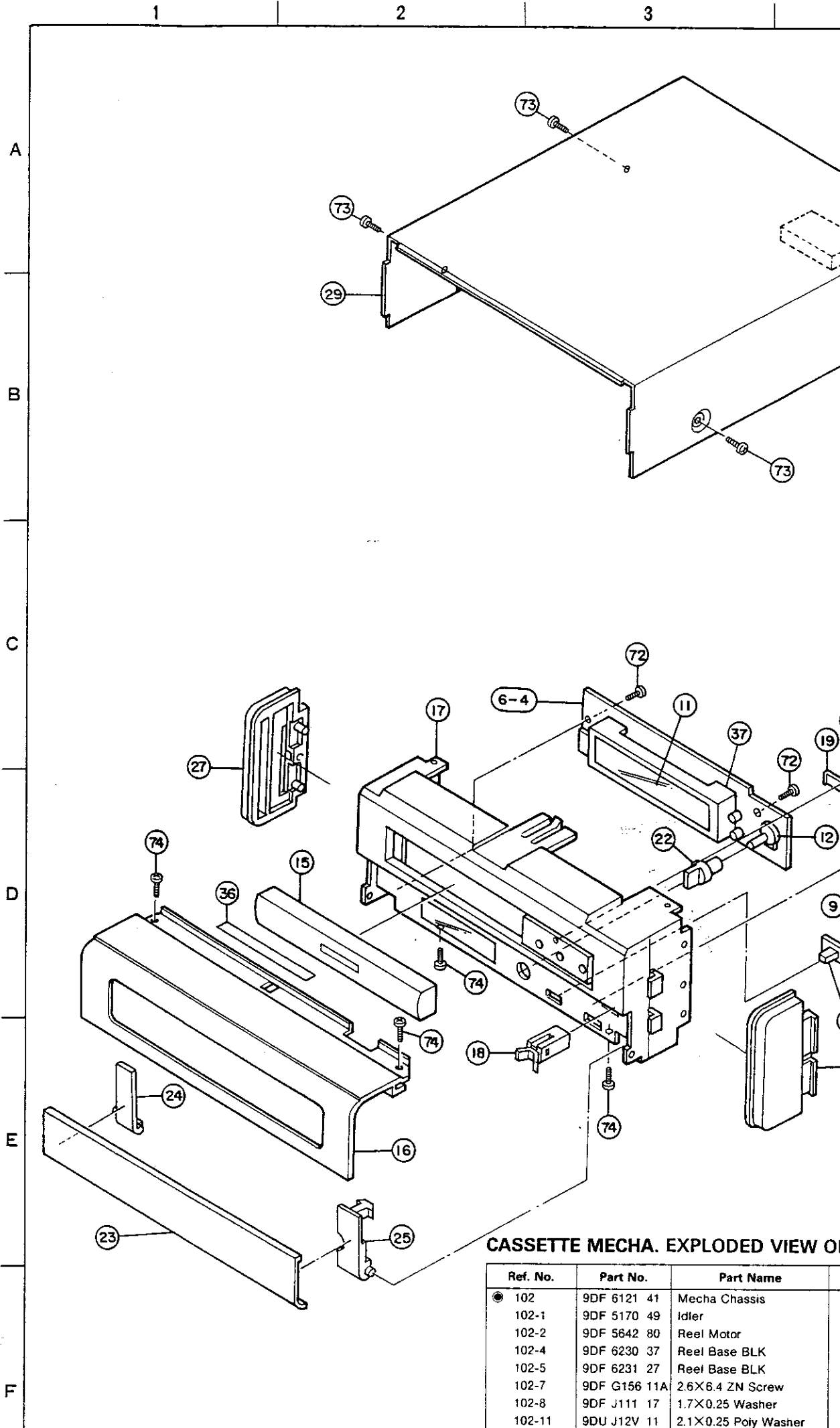

CASSETTE MECHA. EXPLODED VIEW OF

Ref. No.	Part No.	Part Name
● 102	9DF 6121 41	Mecha Chassis
102-1	9DF 5170 49	Idler
102-2	9DF 5642 80	Reel Motor
102-4	9DF 6230 37	Reel Base BLK
102-5	9DF 6231 27	Reel Base BLK
102-7	9DF G156 11A	2.6X6.4 ZN Screw
102-8	9DF J111 17	1.7X0.25 Washer
102-11	9DU J12V 11	2.1X0.25 Poly Washer
103	9DF 5136 05	Head Blk
103-1	9DA Z14T 00	SPI-320AB
103-3	9DF 7690 16	Head Housing
103-3-9	9DF C47E 12	Head Adjust Spring
103-3-10	9DU G13A 11	1.7X5.2 ZNT Screw
103-8	9DF K20P 15	Rotate Spring
103-9	9DF K26N 14	HB Spring
103-11	9DU G19D 11	TT2.0X5 ZN Screw
● 103-17	9DWH57S 00	Wire Connector (E)
● 103-18	9DWH57R 02	Wire Connector (R/P)
● 103-21	9DWH47U 01A	Wire Connector (Q.S)
104	9DF 525S 270	Main Motor Ass'y

NOTE FOR PARTS LIST

- Part indicated with the mark "●" are not always in stock and possibly to take a long period of time for supplying, or in some case supplying of part may be refused.
- When ordering of part, clearly indicate "1" and "1" (i) to avoid mis-supplying.
- Ordering part without stating its part number can not be supplied.
- Part indicated with the mark "★" is not illustrated in the exploded view.

WARNING:

Parts marked with this symbol have critical characteristics. Use ONLY replacement parts recommended by the manufacturer.

EXPLODED VIEW

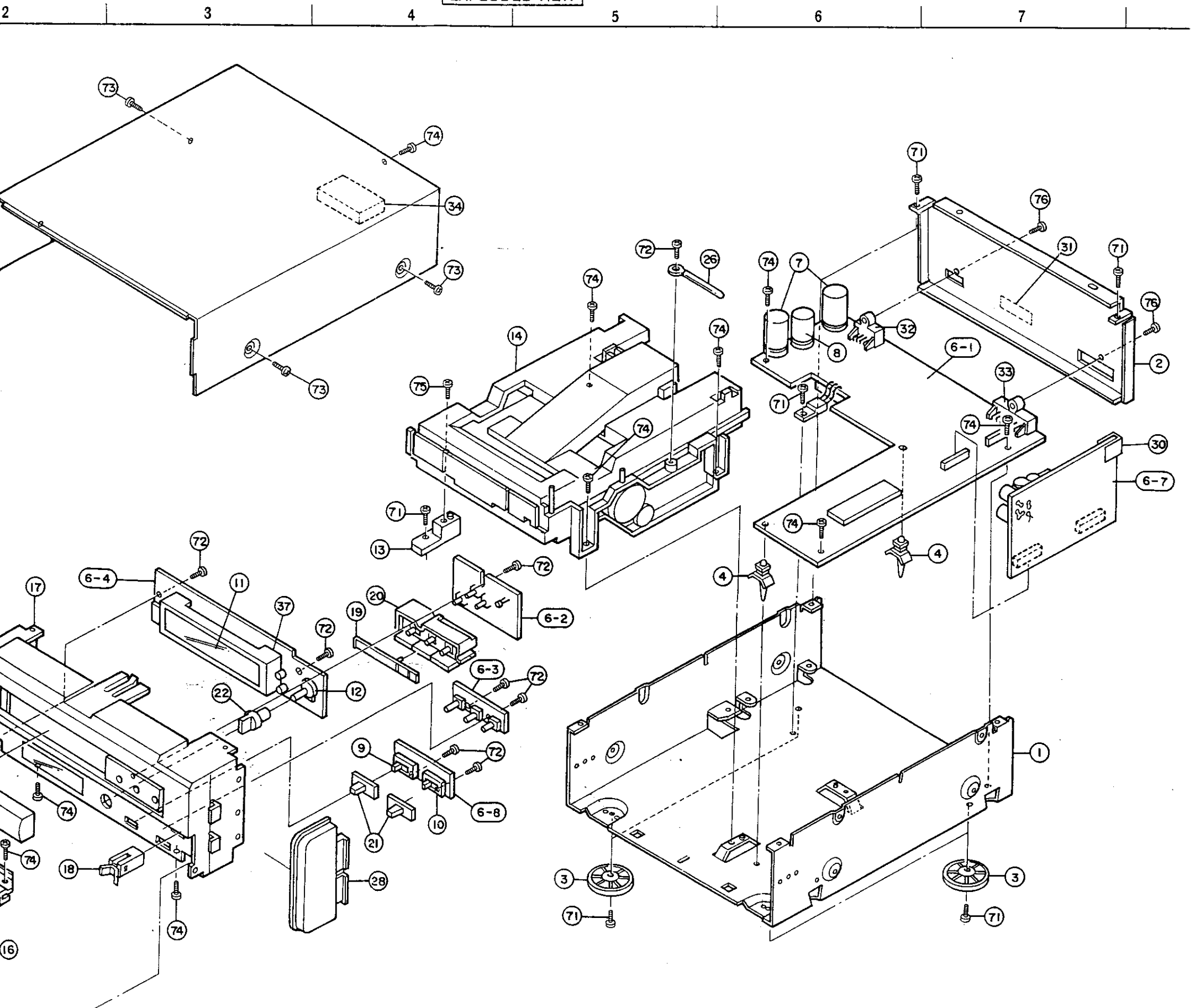

CASSETTE MECHA. EXPLODED VIEW OF PARTS LIST

Ref. No.	Part No.	Part Name	Remarks	Q'ty	Ref. No.	Part No.	Part Name	Remarks	Q'ty	Ref. No.	Part No.	Part Name	Remarks
● 102	9DF 6121 41	Mecha Chassis		1	104-4	9DU G12W12	Motor Fixing Screw		3	151	9DF 7652 63	Solenoid Ass'y	
102-1	9DF 5170 49	Idler		1	104-5	9DF J115 12	Motor Cushion		3	152	9DF L39H 12A	Fix Metal Bar	
102-2	9DF 5642 80	Reel Motor		1	● 105	9DF 5673 83	Control P.W.P.		1	153	9DF L39K 12	Plunger	
102-4	9DF 6230 37	Reel Base BLK		1	105-13	9DA Z15S 00	Reel	GP2S04B	1	● 161	9DF 5732 00	Plate Hold Ass'y	
102-5	9DF 6231 27	Reel Base BLK		1	105-17	9DU E16E 11	Push Switch		5	161-2	9DF J111 18	Poly Washer 2.1X0.25	
102-7	9DF G156 11A	2.6X6.4 ZN Screw		2	109	9DF C52F 15	Slide Plate		1	161-3	9DF J123 28	1.7X0.25 Washer	
102-8	9DF J111 17	1.7X0.25 Washer		2	110	9DF D45H 15	Holder		1	161-5	9DF R22N 12	Middle Pulley	
102-11	9DU J12V 11	2.1X0.25 Poly Washer		2	112	9DF D45G 12	Play Arm		1	161-7	9DU J13L 11	Square Spacer	
103	9DF 5136 05	Head Blk		1	114	9DF D45B 16	Cam Gear (3R)		1	163	9DK G194 28	TT2.6X4.7N Screw	
103-1	9DA Z14T 00	SPI-320AB		1	115	9DF D445 14	Rec Sensor Arm		3	164	9DU G12H 14	2.6X8 ZN Wave Screw	
103-3	9DF 7690 06	Head Housing		1	116	9DF D45L 11	Pack Sensor Arm (P)		1	165	9DF F18A 11	Main Belt	
103-3-9	9DF C47E 12	Head Adjust Spring		1	117	9DF D44V 12	Metal Sensor Arm (L)		1	170	9DU G19C 11	M2.6X25 S Tite Screw	
103-3-10	9DU G13A 11	1.7X5.2 ZNT Screw		2	118	9DF F17G 21	Main Belt		1	● 171	445 8004 007	Wire Clamp	
103-8	9DF K20P 15	Rotate Spring		1	120	9DF J111 30	2.6X0.25 Poly W. Washer		2	172	9DU T11R 11	Reflector	
103-9	9DF K26N 14	HB Spring		1	126	9DF K28R 11	Slide Spring		1				
103-11	9DU G19D 11	TT2.0X5 ZN Screw		2	129	9DF R22M 11	Fly Wheel		1				
● 103-17	9DWH57S 00	Wire Connector (E)		1	130	9DF R22E 13	Fly Wheel		1				
● 103-18	9DWH57R 02	Wire Connector (R/P)		1	131	9DF R20L 21A	Pinch Roller Ass'y (R)		1				
● 103-21	9DWH47U 01A	Wire Connector (Q,S)		1	132	9DF R20M 22	Pinch Roller Ass'y (L)		1				
104	9DF 525S 270	Main Motor Ass'y		1	140	9DU G12H 16	3.0X8 ZN Wave Screw		1				

CASSETTE DECK SECTION

CASSETTE MECH. EXPLODED PARTS LIST (HM101)

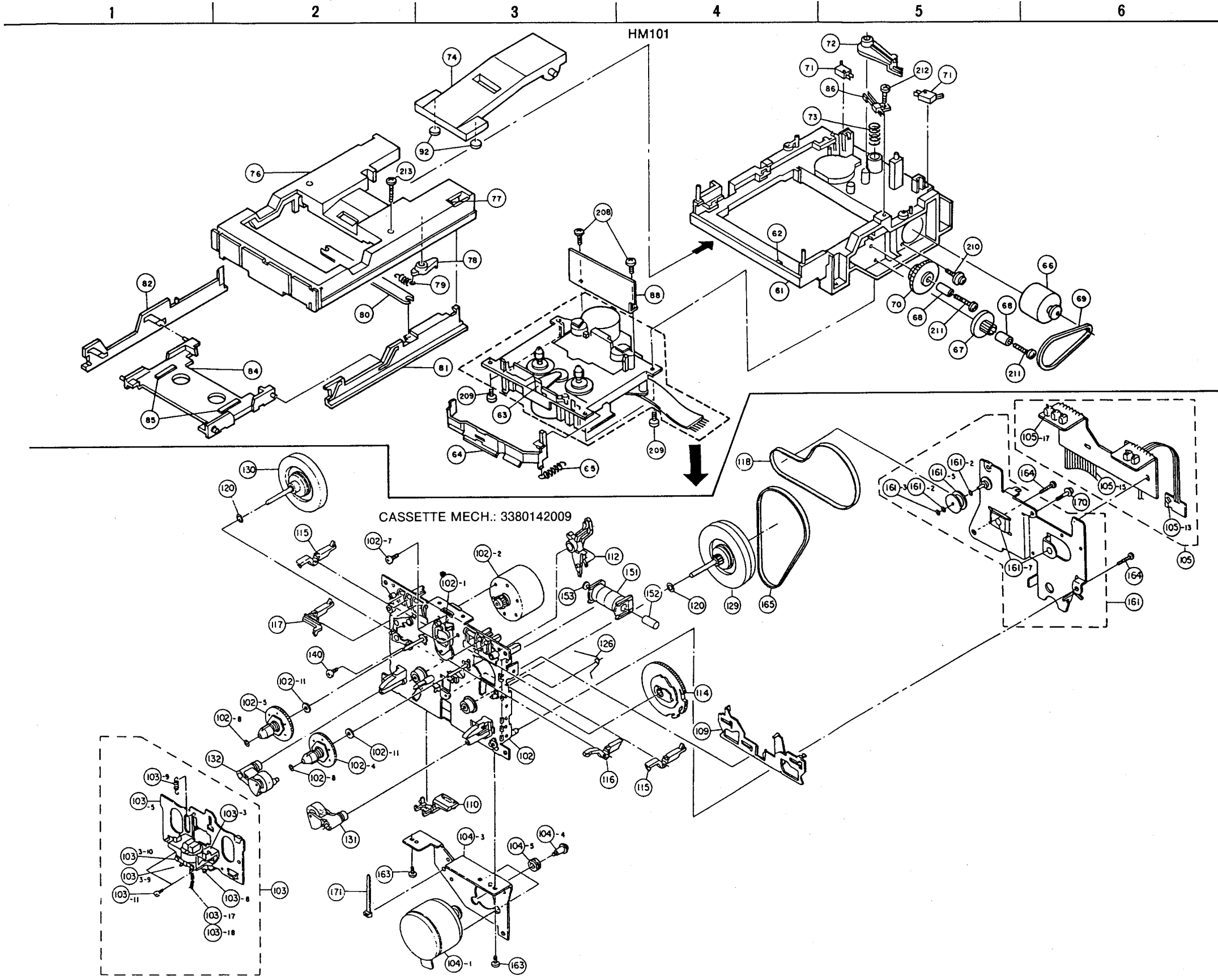

Ref. No.	Part No.	Part Name	Remarks	Qty
61	411 0987 307	Mech. Base		1
62	461 0581 012	Pad		1
63	463 0663 004	Cassette Spring		1
64	412 3084 202	Lever Plate Ass'y		1
65	463 0646 005	Lever Plate Spring		1
66	GEN 1162	Loading Motor Sub Ass'y		1
67	424 0130 008	Pully Gear		1
68	443 0999 004	Callor		2
69	423 0050 004	Belt		1
70	424 0131 007	Gear		1
71	212 4650 004	Leaf Switch		2
72	424 0155 203	Clamper Cam		1
73	463 0644 007	Clamper Arm Spring		1
74	433 0553 304	Clamper Arm		1
75	GEN 1161	Loader Frame Sub Ass'y		1
76	431 0295 200	Loader Frame		1
77	461 0581 009	Pad		1
78	424 0158 103	Stopper Cam		1
79	463 0647 004	Stopper Cam Spring		1
80	412 3084 200	Cam Plate		1
81	424 0157 308	Slide Cam (R)		1
82	424 0156 105	Slide Cam (L)		1
83	GEN 1311	Cassette Tray Sub Ass'y		1
84	431 0296 306	Cassette Tray		1
85	461 0593 000	Tray Pad		2
86	212 6011 007	Leaf Switch		1
★ 87	203 0288 007	1P Contact Ass'y		1
88	412 3083 007	Shield Plate		1
★ 89	203 4508 000	3P PH Connector Cord (Blue)		1
★ 90	203 4438 006	3P PH Connector Cord (Red)		1
★ 91	203 4736 005	3P PH Connector Cord		1
92	461 0613 003	Pad (Circule)		2
★ 93	445 8004 007	Wire Clamper		1
94				

SCREWS				Qty
208	473 8034 014	Tapping Screw (B) 3X6		2
209	473 7500 015	Tapping Screw (P) 3X8		4
210	477 0262 019	Special Screw		1
211	473 3808 009	Tapping Screw (1) 3X25		2
212	473 7505 007	Tapping Screw (P) 2.6X8		1
213	473 7501 027	Tapping Screw (P) 3X16		1
214				

A
B
C
D
E

CD SECTION

PART NAMES AND FUNCTIONS

CD PLAYER

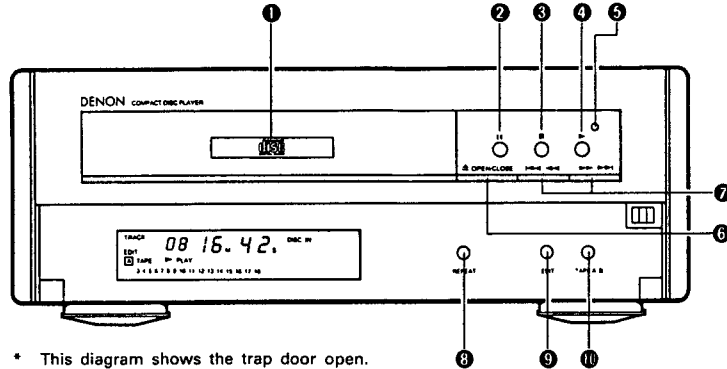

* This diagram shows the trap door open.

- 1 Disc tray**
The disc tray opens forward when the OPEN/CLOSE button 6 is pressed.
To close the disc tray, press the OPEN/CLOSE button 6 again.
- 2 II PAUSE button**
Press this button to stop playback temporarily.
Press the PLAY button to resume playback.
- 3 ■ STOP button**
Press this button to stop playback.
- 4 ▶ PLAY button**
Press this button to start playing the disc.
If pressed when the disc holder is open, the disc holder closes and playback begins.
- 5 Play indicator**
This lights when the disc is played and sound is output.
- 6 OPEN/CLOSE button**
Press this button to open and close the disc holder.
Press once to open the disc holder forward, then press again to close the disc holder.

- 7 ◀◀◀ (automatic/manual search reverse button)**
Press this button to move the pickup back to the beginning of the desired track.
Press in the play or pause mode to move back a number of tracks equal to the number of times the button is pressed.
- ▶▶▶ (automatic/manual search forward button)**
Press this button to move the pickup forward to the beginning of the desired track.
Press in the play or pause mode to move forward a number of tracks equal to the number of times the button is pressed.
* The automatic search function is set if the button is released within 0.5 seconds, and the manual search function is set if the button is held in for more than 0.5 seconds.
- 8 REPEAT button**
Press this button for repeat playback.
- 9 EDIT button**
Press this button for edited recording (dividing the tracks to be recorded to fit onto sides A and B of a tape according to the tape's length).
- 10 TAPE A/B button**
Press this button during editing to switch the display between the display for side A and the display for side B of the tape.

CD PLAYER DISPLAY

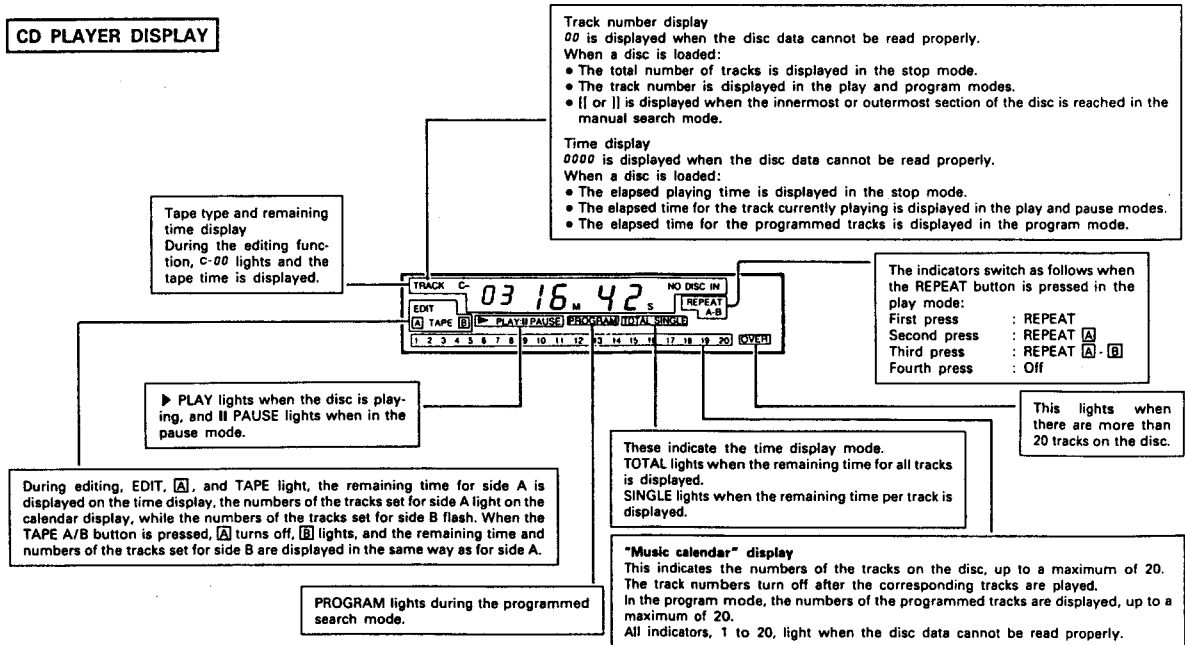

• NO DISC lights on the display if no disc is loaded, or if the disc is loaded upside-down or is heavily scratched or dirty.

REMOVAL OF EACH SECTION

(Follow this procedure in the reverse order when assembling.)

1. Removal of the top cover

- ① Remove the 5 screws which fasten the top cover.
- ② Press the ▲ OPEN/CLOSE button and eject the CD tray.
- ③ Remove the loader panel (D) assembly in the direction of the arrow.
- ④ Press the ▲ OPEN/CLOSE button and retract the CD tray.
- ⑤ Remove the 2 screws which fasten the front panel assembly. At this time, remove with care the connector which connects the main unit assembly and the front panel side assembly.

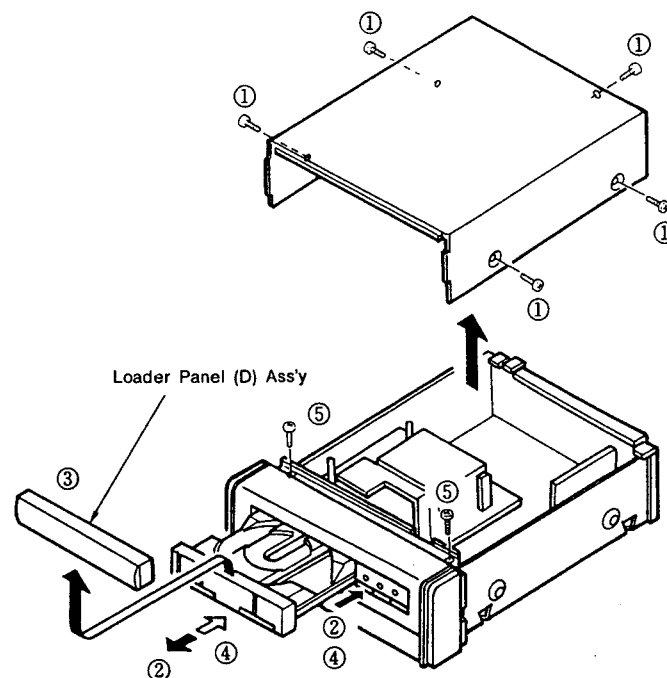

- ⑥ Stand the main unit as illustrated in the diagram and remove the 2 screws which fasten the inner panel assembly.
- ⑦ Slightly loosen the screws of the 2 front legs.
- ⑧ Remove the hooks of the chassis from the inner panel assembly.
- ⑨ Remove the front panel assembly in the direction of the arrow.

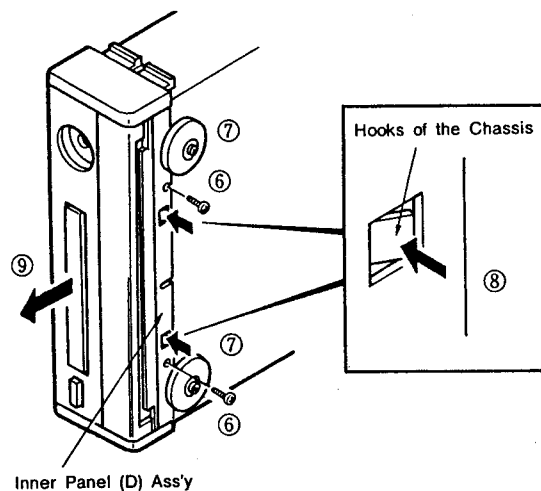

2. Removal of the printed wiring board assembly
LCD UNIT (1U-2280-2)

- ⑩ Remove the 2 screws which fasten the LCD unit.
- ⑪ Remove the 4 screws which fasten the various boards.
- ⑫ Remove the hooks of the inner panel assembly.

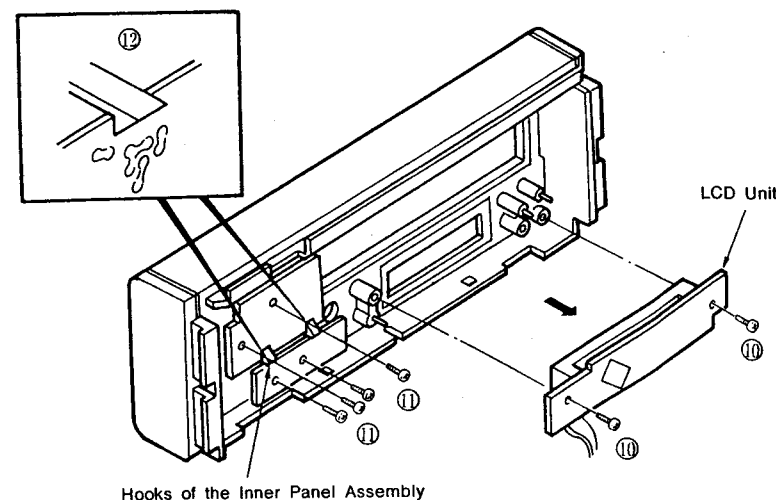

3. Removal of the CD mechanism unit

- ⑬ Remove the 3 screws which fasten the CD mechanism unit. At this time, remove with care the connector which connects the CD mechanism unit and the main unit assembly.

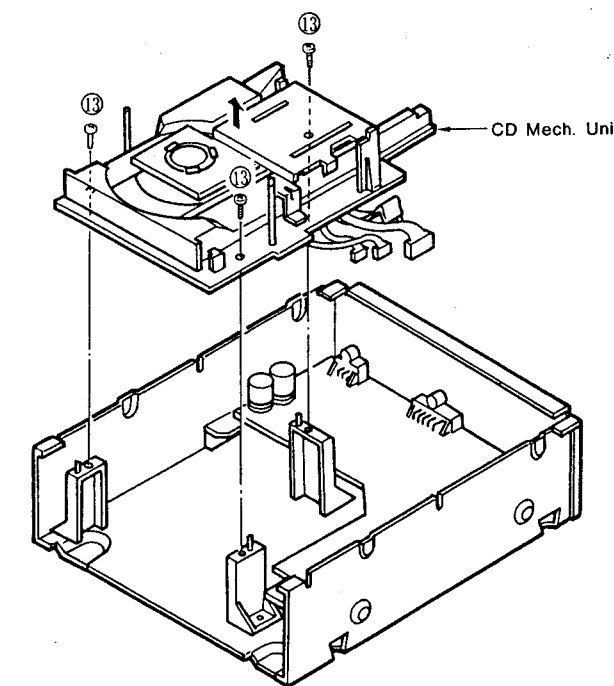

MAIN UNIT ASSEMBLY (1U-2280-1)

- ⑭ Remove the 6 screws which fasten the main unit assembly.
- ⑮ Use radio pliers or another suitable tool to remove the 2 PCB holders which fasten the main unit assembly.

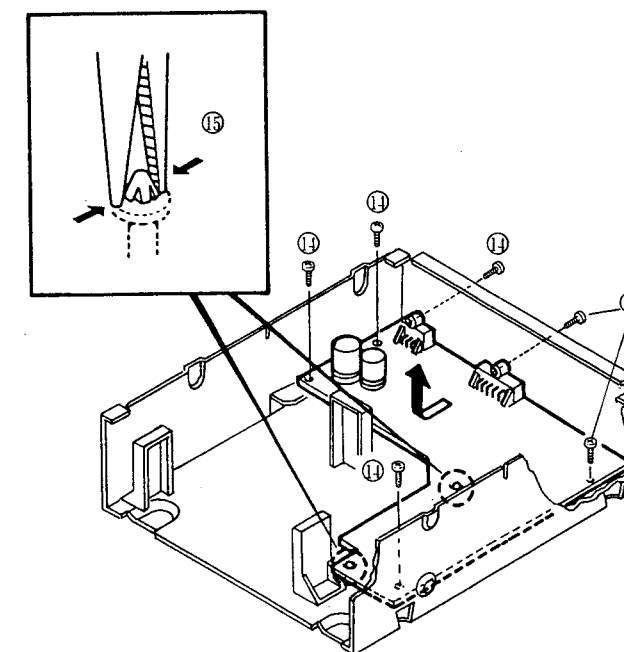

※ Removing connectors (Type 1)

- Hold the top part of the connector, release the lock, and pull out the wires.
- When the lock of the top has not come off, the wires will not come out, so check that the lock has come off.

※ Connecting the connectors (Type 1)

- Press the top of the connector and lock it to the base, fix the bend of the wires, match the polarities, and press in. When the top section is not locked, the wires will come out, so check that the top section is locked.

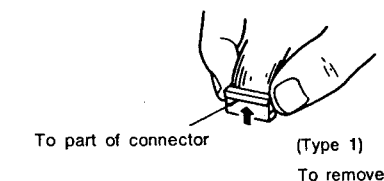

CD SECTION

BLOCK DIAGRAM

1 2 3 4 5 6 7 8

A
B
C
D
E

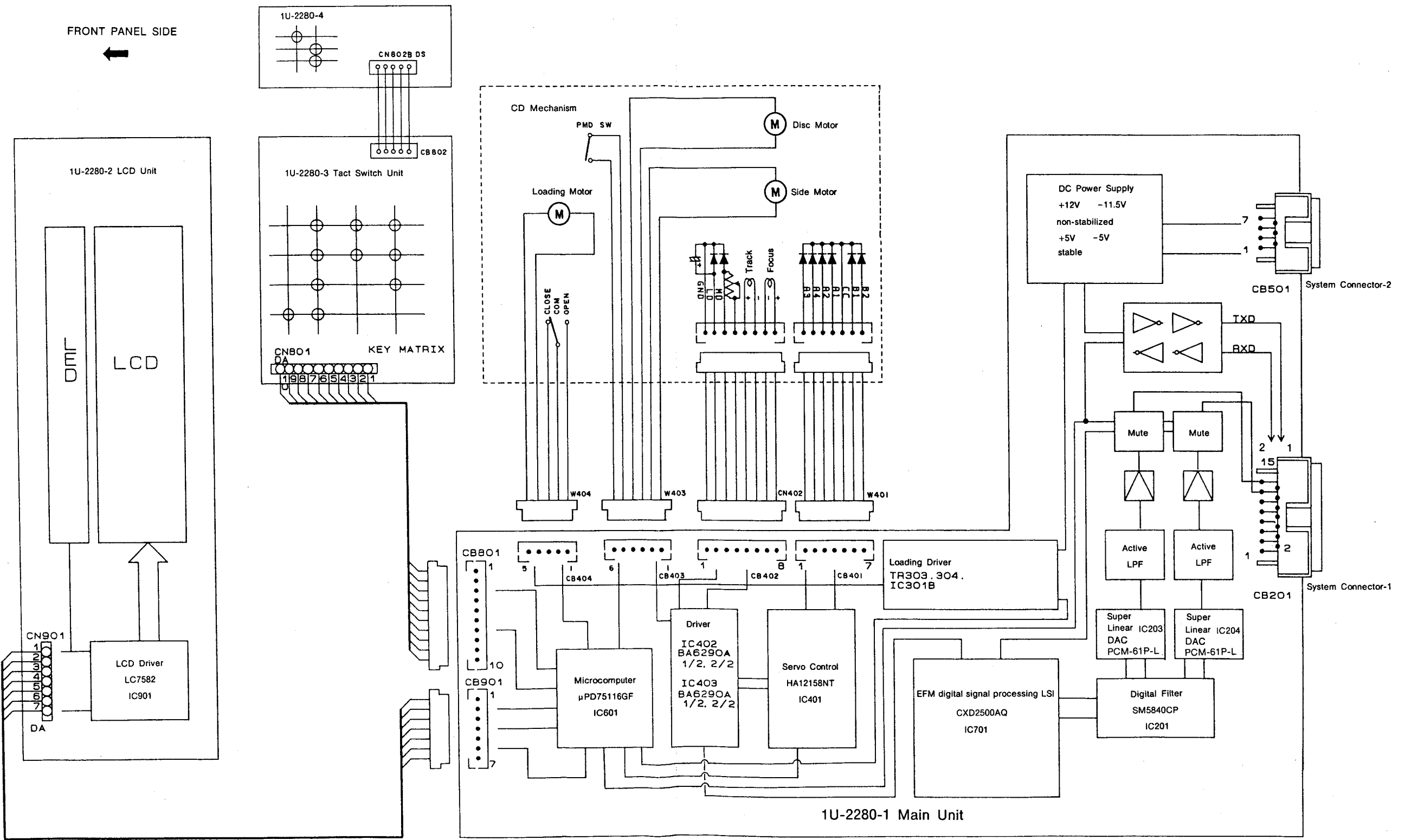

LASER PICKUP

Connections Diagram

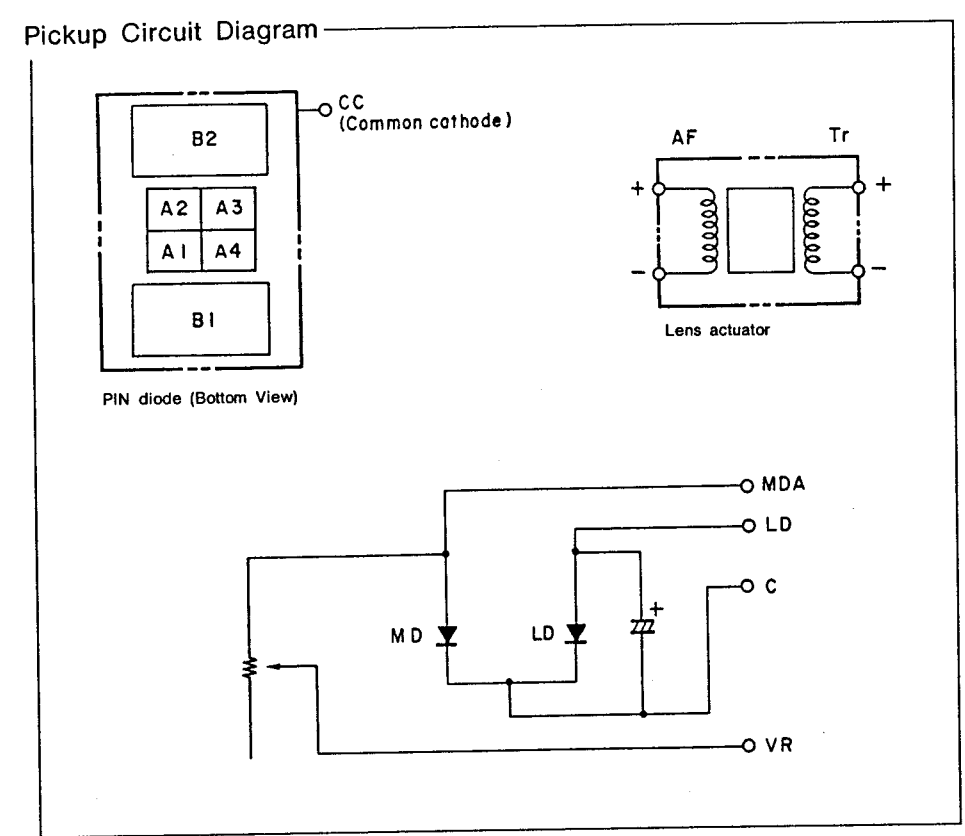

Basic Laser Drive Circuit Diagram

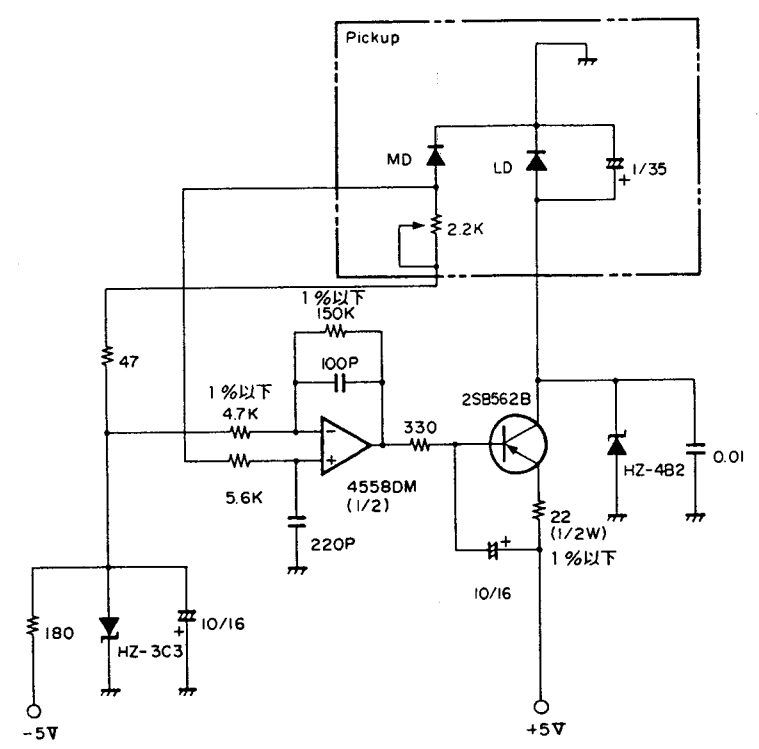

Measuring Circuit Diagram

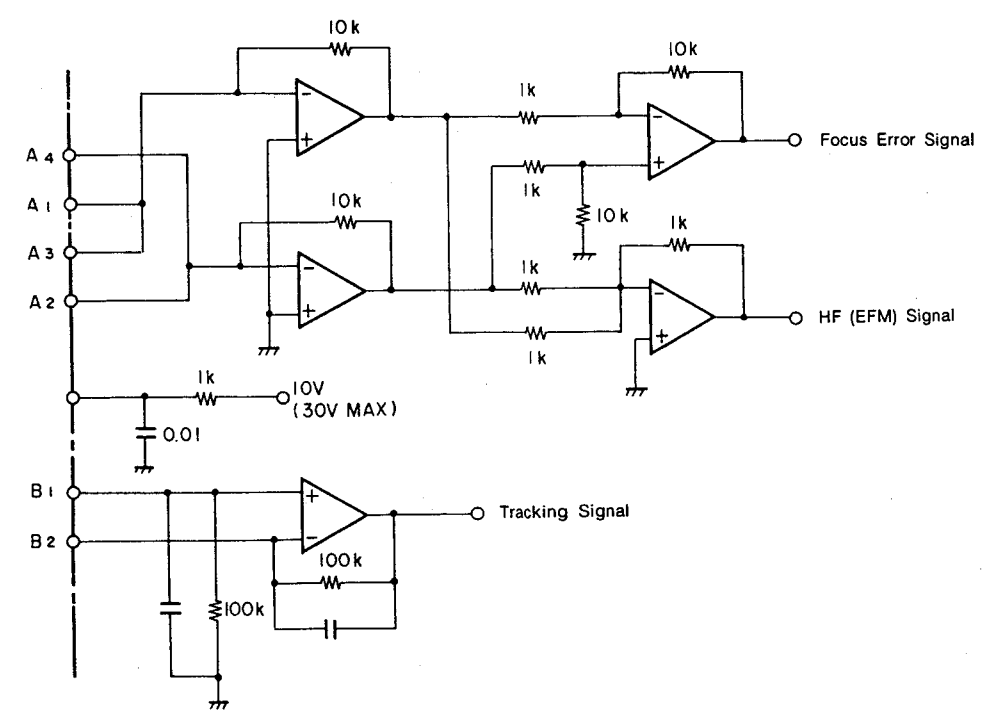

1. PD connector

PH pin post 7 pins (Type number B7B-PH-K-S manufactured by Nippon Atchaku Tanshi Hanbai K.K.)

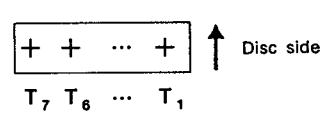

Tn	1	2	3	4	5	6	7
Item	A ₃	A ₄	A ₂	A ₁	CC	B ₁	B ₂

2. LD actuator connector

PH pin post 8 pins (Type number B8B-PH-K-S manufactured by Nippon Atchaku Tanshi Hanbai K.K.)

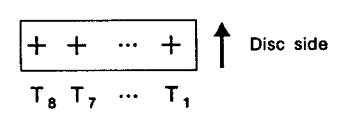

Tn	1	2	3	4	5	6	7	8
Item	C	LD	MDA	VR	TR+	TR-	AF-	AF+

CD SECTION

● Precautions in Use

Read the following carefully before handling.

1. Laser control circuit

The light output of the laser diode (LD) is greatly affected by temperature, so a built-in monitor photodiode should be used in the LD to supplement the light output.

In order to get rid of the dispersion of the monitor photodiode, the semiconductor resistor accompanying the pickup has been adjusted so that the mirror surface level of the HF signal becomes 250 mV when the measurement circuit of this manual and the basic laser drive circuit are used. When designing a new laser drive circuit, note that the life of the laser will be shortened when the mirror level of the HF signal becomes 275 mV with this measuring circuit.

2. Wiring

Be sure to use the specified connectors for the wiring.

Note that the eye pattern may deteriorate when there is a microprocessor or other digital noise source in the vicinity from the photodiode to the harness.

Note that a poor connection related to the LD and actuator connector will cause deterioration of the laser, and so there should not be any looseness of connectors.

● Precautions in Handling

This mechanism has been precisely assembled and adjusted at a special factory. It should not be disassembled or adjusted without good reason. Pay attention to the following points related to handling.

1. General items

(1) Storage

Avoid storage in places with high temperatures and high humidity, and in places exposed to a lot of dust.

(2) Handling

The unit has been precisely adjusted and care should be taken so as not to expose the unit to shocks through dropping or careless handling.

2. Semiconductor laser (LD)

(1) Protection of the eyes from the laser

The output of the LD is via an objective lens and is a maximum of 400 μW, but reaches approximately $1.3 \times 10^4 \text{ W/cm}^2$ in places where there is condensed light. After being condensed by the objective lens, the beam widens and so is all right at a distance of 30 cm or further, but during operation the LD should never be allowed to be viewed directly or through another lens or mirror since this is dangerous.

(2) Destruction by surge currents or static electricity

When a large current flows through the LD, even for a very short period, the strong light which the LD generates itself will advance the deterioration of the LD or destroy it.

Wire a switch into the LD drive circuit or provide another method of preventing the flow of surge currents. Also, when handled without care, the LD can be destroyed instantly by the application of static electricity from the body. Therefore, when handling the LD, be sure to ground your body and ground the measuring instruments, jigs, and tools. It is also desirable to use a grounding mat on the work bench and floor.

3. Lens actuator

(1) The actuator section uses a strong magnetic circuit, so that when magnetic bodies come too close, their characteristics are altered.

Also be careful not to allow foreign matter to enter from the cover gap.

(2) Lens cleaning

Dust or dirt adhering to the objective lens will change the performance.

To clean, blow the dirt away with clean air from an air blower.

4. Handling

Be sure not to contact the lens when handling the LD.

Note that direct contact of the body or other objects with the circuit of the LD board will cause deterioration to occur, so sufficient care should be taken.

SERVICE POINTS

1. Parts replacement of the tray mechanism (Figs. 1 and 2)

(1) Removal of the tray

Open the tray and use a flat-bladed screwdriver to press the stopper portions of Fig. 1 (one each in the left and right locations) in the direction of the black arrow, then remove in the direction of the white arrow.

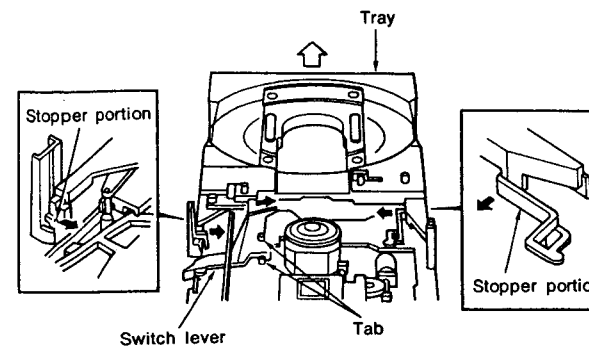

Fig. 1

(2) Mounting of the tray (Figs. 1, 2, and 3)

Rotate the switch lever in the direction of the arrow, set the latches of the tray as illustrated in Fig. 2, then align the rails of the tray in the grooves of the loading plate, and insert so that the pinch lever pins of the switch lever enter into the rack grooves. Push in the tray while pressing the stopper portion inside a little.

(Check that the latches are in the positions illustrated in Fig. 2.)

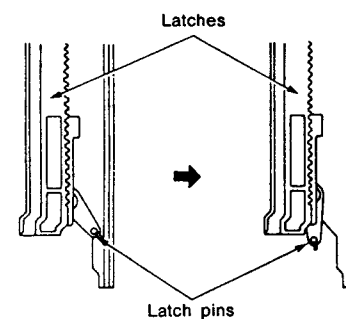

Fig. 2

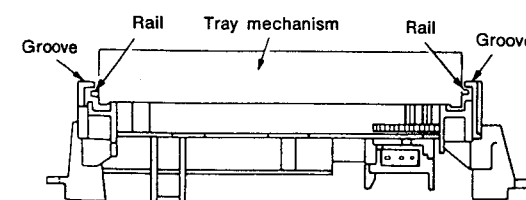

Fig. 3

(3) Replacement of the disc holder (Fig. 4)

With the tray removed, remove tabs (D) and (E) of the disc receptacle of Fig. 4, then lift up and off.

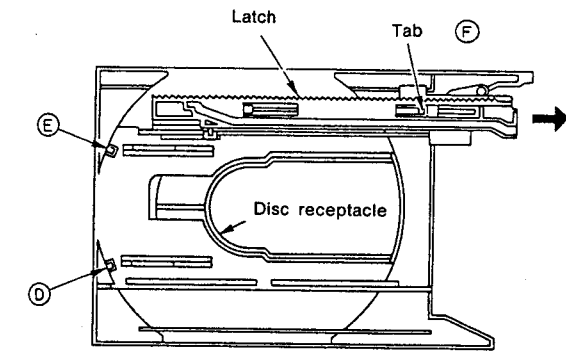

Fig. 4

(4) Replacement of the latches (Fig. 4)

Set the latches into the condition of Fig. 4, lift the latch tab (F) up about 1 mm with a flat-bladed screwdriver and remove the rack in the direction of the arrow.

(5) Removal of the loading motor and switches (Fig. 5)

Remove the belt from the loading motor, then remove the 3 tabs. Remove the fixed tabs from the various switches.

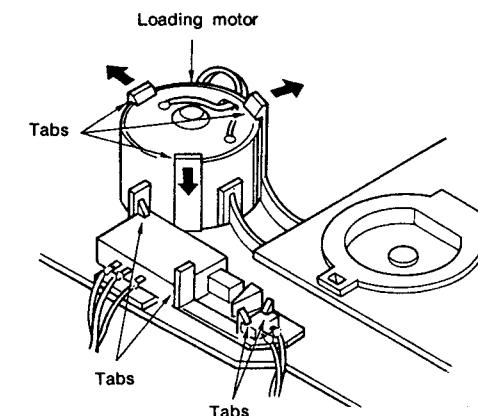

Fig. 5

(6) Replacement of the belt

Replace the belt with the tray removed.

(7) Replacement of the clasper (Fig. 6)

Hook the elongated holes of the clasper onto the C arm, bend the elongated hole sections and attach.

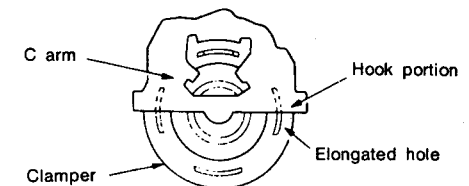

Fig. 6

(8) Replacement of the switch lever (Fig. 1)

Remove the tabs of the bottom side (in 2 locations).

2. Removal of the unit mechanism (Fig. 7)

After removing the loading mechanism, remove the tab of the bottom surface (in one location) as illustrated in Fig. 7.

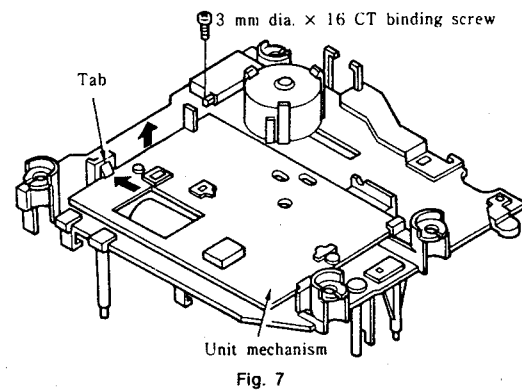

(1) To replace the DC motor (D2) and the turntable, follow the procedure below

- 1) Pull the turntable (plastic) off vertically from the unit plate.
- 2) When fitting on the servicing turntable (metal), make a height adjustment. (Fig. 8)

Do not exert excessive force to the shaft of the DC motor (D2) at this time.

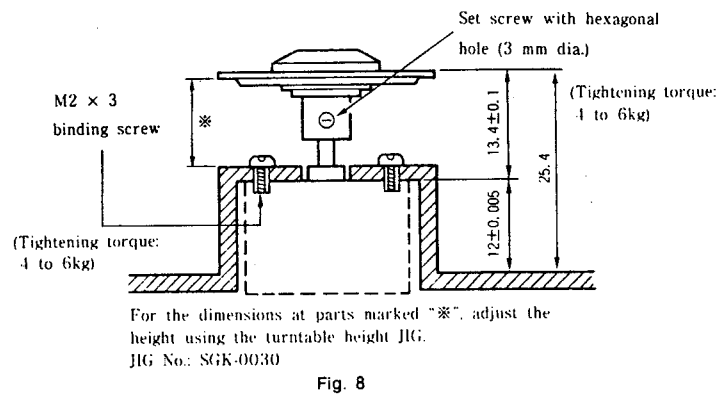

- 3) At the time of service replacement of the DC motor (D2), do not apply excessive force in direction B. When part C of the unit plate is misshapen, it will cause eye pattern deterioration. (Fig. 9)

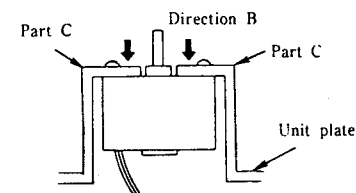

Fig. 9

NOTE:

- Motor replacement or turntable replacement method
Remove the pressure-fitted turntable, and remove the motor screws.
- Do not reuse a turntable (plastic) that has been removed once.

- (2) When disassembling and assembling the unit mechanism, assemble with wiring resembling that of Fig. 10

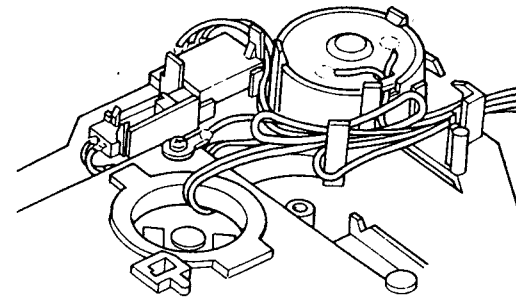

Fig. 10

3. Inspection of the objective lens (Fig. 11)

Handle so as not to get dirt or dust on the objective lens of the lens actuator section. Note that when used for a long period, dirt or dust may have adhered to the objective lens. Try cleaning the surface of the objective lens with a dry, clean cotton swab.

If the dirt still does not come off, moisten the cotton swab with a small amount of water and wipe. When doing this, be careful not to get water on any parts other than the lens.

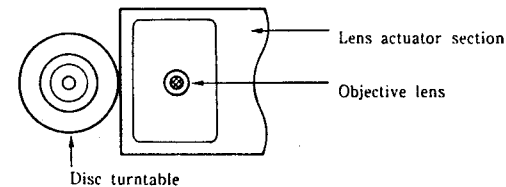

Fig. 11

4. Inspection for laser breakdown

The laser is normally driven with a current of 30 to 80 mA. If this laser drive current value is measured at 120 mA or higher in the circuit, the laser may be thought to be faulty. (The current value is measured by taking the voltage (0.99 to 3.3 V) across both ends of R401, which is 33 ohms).

5. Precautions at time of servicing (Fig. 12)

(1) Semiconductor laser

The semiconductor laser is very susceptible to static electricity, destruction and surge currents. Be careful never to touch the terminals of the semiconductor laser and the terminals of the flexible board with your hands or a tool.

As illustrated in Fig. 12, the current and light intensity characteristics increase abruptly once the threshold current value is exceeded.

Also note that this threshold current differs a little from laser to laser. In view of this, when replacing the unit mechanism or any work that involves setting the amount of light of the laser, be sure to turn the adjustment control VR401 fully in the counterclockwise direction, and then raise it to the specified value.

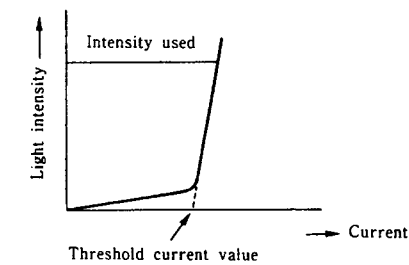

Fig. 12

(2) Handling the unit mechanism (Fig. 13)

When handling the pickup mechanism and the unit mechanism, use a ground ring such as the one illustrated in Fig. 13. (A ground ring can be constructed using ordinary lead wire.)

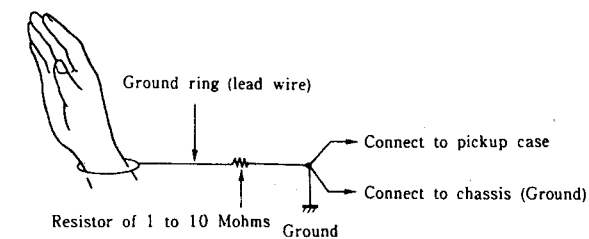

Fig. 13

6. Inspection of the actuator (Fig. 14)

Check the resistance value of the actuator coil. It is normal if the values are as follows:

Focusing coil	30 ohms
Tracking coil	10 ohms

If the coils are open or shorted, the actuator may be thought to be broken. Also, a 1.5 V battery can be used to observe if the lens moves.

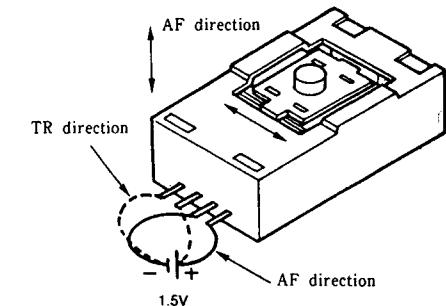

Fig. 14

CD SECTION

ADJUSTMENT METHOD

The microprocessor contained in this unit incorporates a service program which allows a wide variety of service adjustments to be conducted easily by using the operation buttons.

1. Method of starting the service program

NOTE: When the service program starts, normal operations are not longer possible with the operation buttons.

2. Operation functions when the service program is operating

Operation button	Operation function	Description
▲ OPEN/CLOSE	Opens and closes the disc holder.	<ul style="list-style-type: none"> ● Opening and closing takes place when the rotation of the disc has stopped. ● Other operation buttons are performed when the opening and closing operation is completed.
■ STOP	Stops system operation.	<ul style="list-style-type: none"> ● Track number display becomes <i>D 1</i>. ● Press when an adjustment has been completed or is redone.
▶ PLAY	Operates the focus servo and rotates the disc.	<ul style="list-style-type: none"> ● Press at the time of the tracking offset adjustment. ● After the operation is completed, the track number display becomes <i>D 2</i>.
PAUSE	Operates the focus servo, tracking servo, slide servo, and the spindle servo.	<ul style="list-style-type: none"> ● When the play button has been pressed, the tracking servo and slide servo are operated. ● After the operation is completed the track number display becomes <i>D 3</i>.
Other buttons	Operation is not normal.	<ul style="list-style-type: none"> ● Do not operate buttons other than the above. ● When a button is operated by mistake, immediately turn the power switch off.

NOTE: Do not use the remote control while the service program is operating.

3. Adjustment method

(1) Measuring instruments required in the adjustment

- ① DC voltmeter
- ② Oscilloscope

Outline Diagram of Adjustment Locations

1U-2280A-1 CD Unit (Component Side)

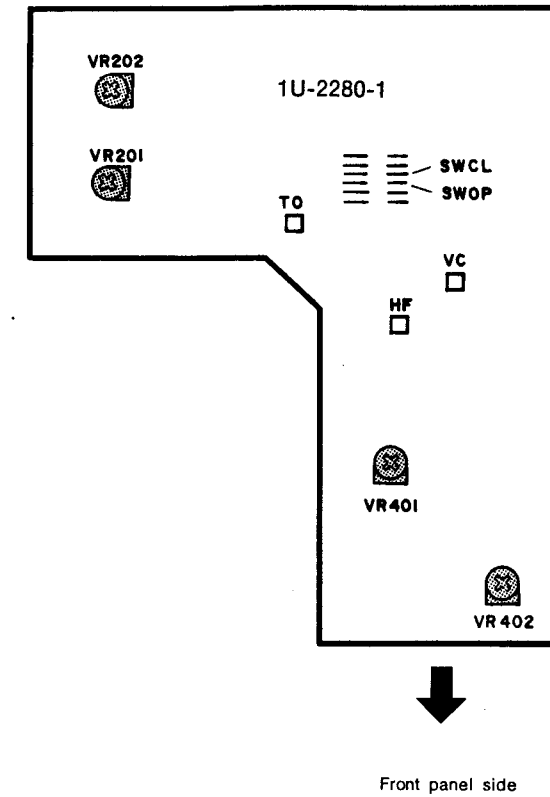

NOTE: VR201 and 202 are adjusted at the factory before shipping and there is no need to adjust.

(2) Adjustment preparation

1.	Set the adjustment control (VR401, 402) to the position illustrated.	<p>VR401 (T-OFFSET)</p> <p>VR402 (F-OFFSET)</p>
2.	Adjustment step	<ul style="list-style-type: none"> 1. Tracking offset 2. Focus offset

(3) Tracking offset adjustment

Wiring Diagram	
Adjustment location	Adjustment Procedure
(Control)	
VR401	1. Adjust the VR401 "T-OFFSET" control and set the $0mV \pm 5mV$.

(4) Focus offset Adjustment

Wiring diagram			
Oscilloscope		Adjustment location	Check items
V	H	Control	Oscilloscope
50mV/div or 20mV/div	0.2 μ /div or 0.5 μ /div	VR402	<p>Adjust for Fine waveform</p>
Adjustment Procedure			
<p>1. Press the ▶ PLAY button.</p> <p>2. Adjust VR402 ("F-OFFSET") so that the eye pattern jitter is minimum.</p>			

CD SECTION

PRINTED WIRING BOARD

1

2

3

4

5

6

7

8

1U-2280A CD UNIT ASS'Y

Component Side

A

B

C

D

E

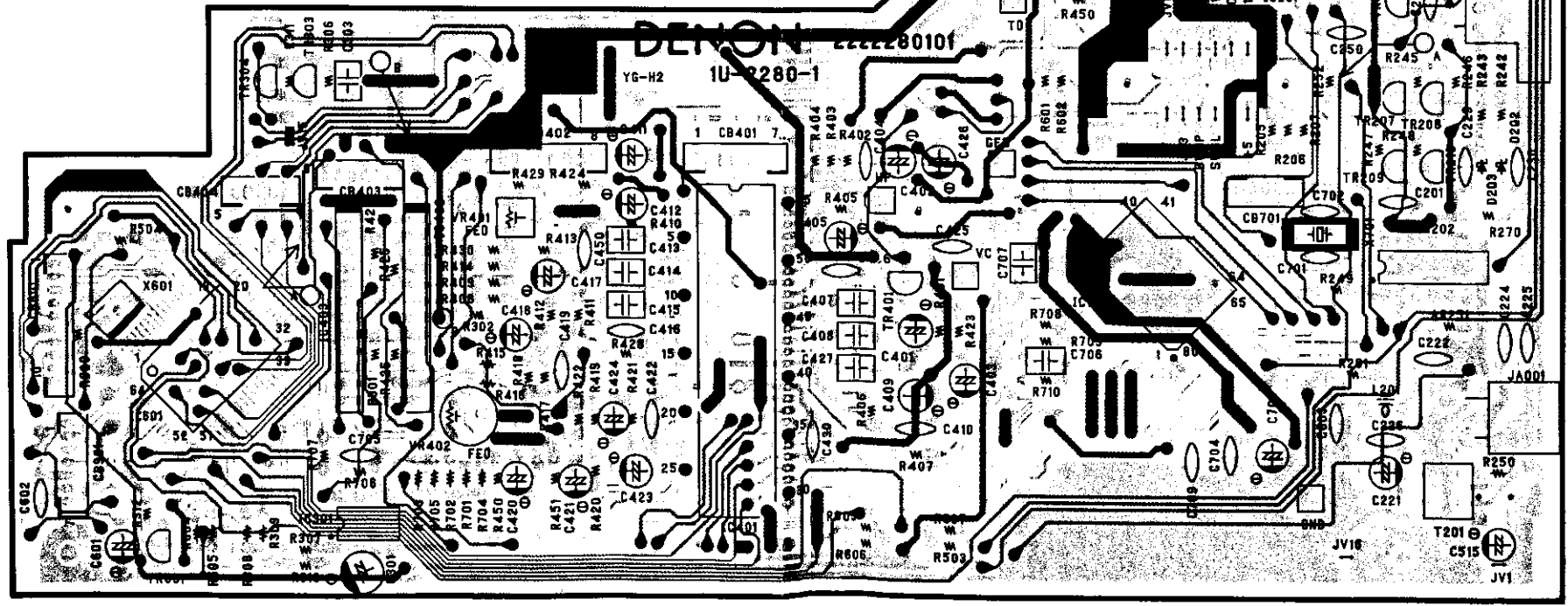
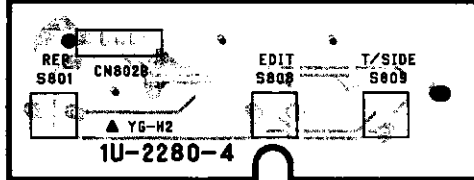
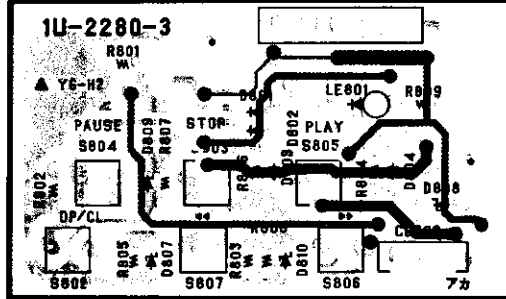
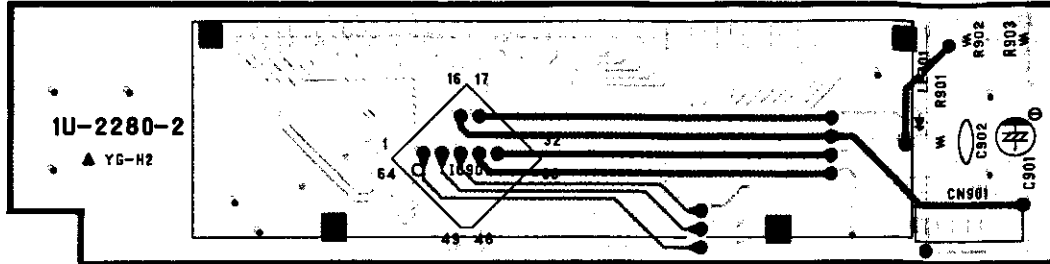

CD SECTION

1 2 3 4 5 6 7 8

Pattern Side

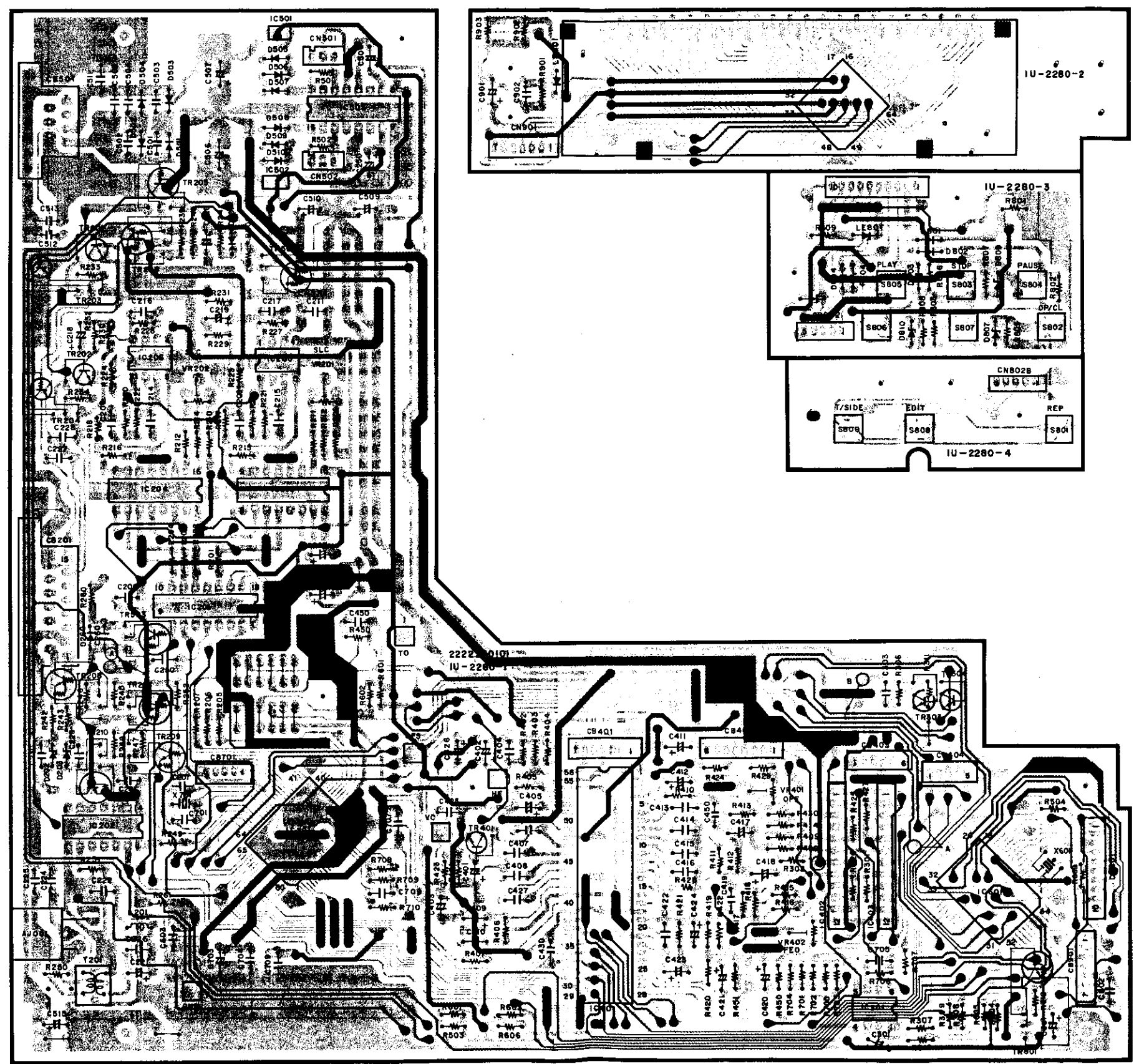

A
B
C
D
E

CD SECTION

NOTES ON THE PARTS TABLE

NOTE FOR PARTS LIST

- Part indicated with the mark "⊙" are not always in stock and possibly to take a long period of time for supplying, or in some case supplying of part may be refused.
- When ordering of part, clearly indicate "1" and "I" (i) to avoid mis-supplying.
- Ordering part without stating its part number can not be supplied.
- Part indicated with the mark "★" is not illustrated in the exploded view.
- Not including Carbon Film ±5%, 1/6 W, 1/4W Type in the P. W. Board parts list.
- Parts marked with this symbol Δ have critical characteristics. Use ONLY replacement parts recommended by the manufacturer.
- Refer to the following table for the codes of the resistors and capacitors appearing on the parts list.

Resistors

Ex.: **RN** **14K** **2E** **182** **G** **FR**

Type	Shape and performance	Power	Resistance	Allowable error	Others
RD : Carbon	2B : 1/4W	F : ±1%	P : Pulse-resistant type		
RC : Fixed	2E : 1/2W	G : ±2%	NL : Low noise type		
RS : Metallic film	2H : 3/4W	J : ±5%	NB : Non-burning type		
RW : Winding	3A : 1W	K : ±10%	FR : Fuse resistor		
RN : Metal film	3D : 2W	M : ±20%	F : Lead wire forming		
RK : Metal mixture	3F : 3W				
	3H : 5W				

★ Resistance
 1 8 2 ⇒ 1800 ohm = 1.8 kohm
 Indicates number of zeros after effective number
 2-digit effective number, decimal point indicated by R.
 • Units: ohm

Capacitors

Ex.: **CE** **04W** **1H** **2R2** **M** **BP**

Type	Shape and performance	Dielectric strength	Capacity	Allowable error	Others
CE : Aluminum foil electrolyte	0J : 6.3V	F : ±1%	HS : High stability type		
CA : Aluminum solid electrolyte	1A : 10V	G : ±2%	BP : Non-polar type		
CS : Tantalum electrolyte	1C : 16V	J : ±5%	HR : Ripple-resistant type		
CQ : Film	1E : 25V	K : ±10%	DL : For charge and discharge		
CK : Ceramic	1V : 35V	M : ±20%	HF : For assuring high frequency		
CC : Ceramic	1H : 50V	Z : +80%	U : UL part		
CP : Oil	2A : 100V	-20%	C : CSA part		
CM : Mica	2B : 125V	P : +100%	W : UL-CSA type		
CF : Metallized	2C : 160V	-0%	F : Lead wire forming		
CH : Metallized	2D : 200V	C : ±0.25pF			
	2E : 250V	D : ±0.5pF			
	2H : 500V	-			
	2J : 630V				

★ Capacity
 2 R 2 ⇒ 2.2 μF
 1-digit effective number, decimal point indicated by R.
 2-digit effective number, decimal point indicated by R.
 • Units: μF, (for P, pF μμF)
 • When the dielectric strength is indicated in AC, "AC" is included after the dielectric strength value.

1U-2280A CD UNIT PARTS LIST

Ref. No.	Part No.	Part Name	Remarks	Ref. No.	Part No.	Part Name	Remarks
SEMICONDUCTORS GROUP							
IC201	262 1450 008	IC SM5840CP		C410	253 9030 060	BC Ceramic 0.01 μF/25V	CK45-1E103K
IC203,204	262 1409 004	IC PCM61P-L		C405	254 4252 006	Electrolytic 10 μF/16V	CE04W1C100M
IC205,206	263 0712 009	IC :RC4558P		C406	253 9031 069	BC Ceramic 2700pF/25V	CK45-1E272K
IC301	263 0712 009	IC :RC4558P		C407	256 1034 018	Metalized 0.033 μF/50V	CF93A1H333J
IC401	263 0749 001	IC HA12158NT		C408	255 1120 042	Film 0.0022 μF/50V	CQ93M1H222J
IC402,403	263 0750 003	IC BA6290A		C409	254 4260 032	Electrolytic 0.47 μF/50V	CE04W1HR47M
IC501,502	268 0073 905	IC ICP-N15	IC Protector	C411	254 4254 006	Electrolytic 10 μF/16V	CE04W1C100M
IC503	263 0693 005	IC M5290P		C412	254 4260 032	Electrolytic 0.47 μF/50V	CE04W1HR47M
IC601	262 1456 206	IC μPD75116GF-E16-3BE	μ-Com	C413	256 1034 047	Metalized 0.056 μF/50V	CF93A1H563J
IC701	262 1514 009	IC CXD2500AQ		C414	256 1034 005	Metalized 0.027 μF/50V	CF93A1H273J
IC901	263 0533 000	IC LC7582		C415	256 1034 005	Metalized 0.15 μF/50V	CF93A1H154J
TR203,204	269 0073 908	Transistor DTC314TS	built in Resistor	C416	253 1179 071	Ceramic 390pF/50V	CK45B1H391K (DD-3)
TR205	269 0046 906	Transistor DTA114ES	built in Resistor	C417	254 4252 019	Electrolytic 22 μF/16V	CE04W1C220M
TR206~209	269 0020 906	Transistor DTC114ES	built in Resistor	C418	254 4260 016	Electrolytic 0.22 μF/50V	CE04W1HR22M
TR210	269 0040 902	Transistor DTC144ES	built in Resistor	C419	253 1004 007	Ceramic 1000pF/50V	CK45B1H102K
TR303	274 0144 907	Transistor :BC368		C420	254 4250 026	Electrolytic 100 μF/6.3V	CE04W0J101M
TR304	272 0101 902	Transistor :BC369		C421	254 4254 006	Electrolytic 10 μF/16V	CE04W1C100M
TR401	271 0102 924	Transistor 2SA1015 (GR)		C422	253 1063 006	Ceramic 5600pF/50V	CK45B1H562K
TR501	274 0136 009	Transistor 2SD1913		C423	254 4260 049	Electrolytic 1 μF/50V	CE04W1H010M
TR502	272 0093 007	Transistor 2SB1274		C424	254 4260 016	Electrolytic 0.22 μF/50V	CE04W1HR22M
TR503,504	269 0020 906	Transistor DTC114ES	built in Resistor	C425	253 9030 060	BC Ceramic 0.01 μF/25V	CK45-1E103K
TR801	269 0046 906	Transistor DTA114ES	built in Resistor	C426	254 4252 024	Electrolytic 47 μF/10V	CE04W1A470J
D201	276 0432 903	Diode 1SS270A		C427	255 1121 026	Film 0.015 μF/50V	CQ93M1H153J
D202,203	276 0462 915	Zener Diode HZS6B-2	6V	C430	253 1004 007	Ceramic 1000pF/50V	CK45B1H102K
D260	276 0462 915	Zener Diode HZS6B-2	6V	C450	253 1004 007	Ceramic 1000pF/50V	CK45B1H102K
D501~510	276 0550 908	Diode 1SR139-200		C506,507	254 4255 704	Electrolytic 3300 μF/16V	CE04W1C332MC
D801~804	276 0432 903	Diode 1SS270A		C508	254 4260 003	Electrolytic 0.1 μF/50V	CE04W1H0R1M
D807~810	276 0462 915	Zener Diode HZS6B-2	6V	C509,510	254 4254 051	Electrolytic 220 μF/16V	CE04W1C221M
LE801	393 9483 902	LED (SLR-34MC70F120)	Green	C513	253 9036 006	BC Ceramic 0.1 μF/25V	CK45-1E104Z
LE901	393 9493 002	LED Ass'y		C520	254 4260 045	Electrolytic 1 μF/50V	CE04W1H010M
LC901	393 4105 007	LCD Ass'y		C601	254 4250 026	Electrolytic 100 μF/6.3V	CE04W0J101M
RESISTORS GROUP (Not included Carbon Film ±5%, 1/4W Type. Refer to the Schematic Diagram for those Parts.)							
R302	245 2369 902	Metal Film 8.2kohm 1% 1/4W	RN14K2E822F	C602	253 1024 003	Ceramic 0.01 μF/50V	CK45F1H103Z
R408	245 2370 946	Metal Film 33kohm 1% 1/4W	RN14K2E333F	C602,603	253 9036 006	BC Ceramic 0.1 μF/25V	CK45-1E104Z
R409	245 2370 904	Metal Film 22kohm 1% 1/4W	RN14K2E223F	C701	253 3596 005	Ceramic 3pF/50V	CC45SL1H030C
R707	245 2370 946	Metal Film 33kohm 1% 1/4W	RN14K2E333F	C702	253 4342 041	Ceramic 5pF/50V	CC45SL1H050C
VR201,202	211 6087 928	Semi Fixed Resistor 100k ohm	V06PB104	C703	254 4250 039	Electrolytic 220 μF/6.3V	CE04W0J221J
VR401	211 6079 910	Semi Fixed Resistor 4.7k ohm	V06PB472	C704	253 9031 027	BC Ceramic 0.1 μF/25V	CK45-1E104K
VR402	211 6064 022	Semi Fixed Resistor 100k ohm	V06PB104	C705	253 9030 060	BC Ceramic 0.01 μF/25V	CK45-1E103K
CAPACITORS GROUP							
C200	253 9031 027	BC Ceramic 0.1 μF/25V	CK45-1E104K	C706	256 1034 034	Metalized 0.047 μF/50V	CF93A1H473J
C201	253 9036 006	BC Ceramic 0.1 μF/25V	CK45-1E104Z	C707	255 1120 026	Film 0.0015 μF/50V	CQ93M1H152J
C202,203	254 4252 037	Electrolytic 100 μF/10V	CE04W1A101M	C709	253 9031 027	BC Ceramic 0.1 μF/25V	CK45-1E104K
C208,209	255 1120 000	Film 0.001 μF/50V	CQ93M1H102J	C901	254 4299 003	Electrolytic 100 μF/16V (SRE)	CE04W1C101M
C211	253 9031 027	BC Ceramic 0.1 μF/25V	CK45-1E104K	C902	253 4350 004	Ceramic 680pF/50V	CC45SL1H681J
C213	253 9031 027	BC Ceramic 0.1 μF/25V	CK45-1E104K				
C214,215	253 3634 006	Ceramic 200pF/50V	CC45SL1H201J				
C216,217	253 3627 000	Ceramic 100pF/50V	CC45SL1H101J				
C218,219	254 4254 048	Electrolytic 100 μF/16V	CE04W1C101M				
C220	254 4254 051	Electrolytic 220 μF/16V	CE04W1C221M				
C227,228	253 3627 000	Ceramic 100pF/50V	CC45SL1H101J				
C229,230	253 3643 000	Ceramic 470pF/50V	CC45SL1H471J				
C250	253 3638 002	Ceramic 300pF/50V	CC45SL1H301J				
C260	253 3643 000	Ceramic 470pF/50V	CC45SL1H471J				
C301	254 4260 061	Electrolytic 3.3 μF/50V	CE04W1H3R3M				
C303	256 1047 005	Metalized 0.022 μF/50V	CF93A1H223JH				
C401	254 4254 006	Electrolytic 10 μF/16V	CE04W1C100M				
C402	254 4299 003	Electrolytic 10 μF/16V (SRE)	CE04W1C100M				
C403	254 4250 026	Electrolytic 100 μF/6.3V	CE04W0J101M				
C404	253 3614 000	Ceramic 100pF/50V	CC45SL1H101J				

CD SECTION

OTHERS PARTS GROUP				Q'ty
	—	(P.W. Board)		(1)
	212 5606 905	Tact Swtich		9
X601	399 0034 002	Ceramic Vibrator	CST4.00MG	1
X701	399 0036 013	X'tal (16.9344MHz)		1
	449 0055 302	LCD Holder		1
CB404	205 0343 058	5P Connector Base (KR-PH)		1
CN802	205 0321 054	5P Connector Base (RED)	Red	1
CB403	205 0343 061	6P Connector Base (KR-PH)		1
CB401,901	205 0343 074	7P Connector Base (KR-PH)		2
CB801	205 0375 000	10P Connector Base (KR-PH)		1
CB201	204 8284 022	15P System Socket		1
CB501	204 2429 003	7P System Socket		1
CN901	204 2312 042	7P KR-DA Connector Cord	ℓ=240	1
CN801	204 2225 016	10P KR-DA Connector Cord	ℓ=150	1
CN802	203 8172 021	5P KR-DS Connector Cord	ℓ=70	1
CB402	205 0343 087	8P Connector Cord (KR-PH)		1
CN501,502	203 4564 044	3P SCN-SON Connector Cord		2

CD SECTION

SEMICONDUCTORS

● IC's

HA12158NT (IC401)

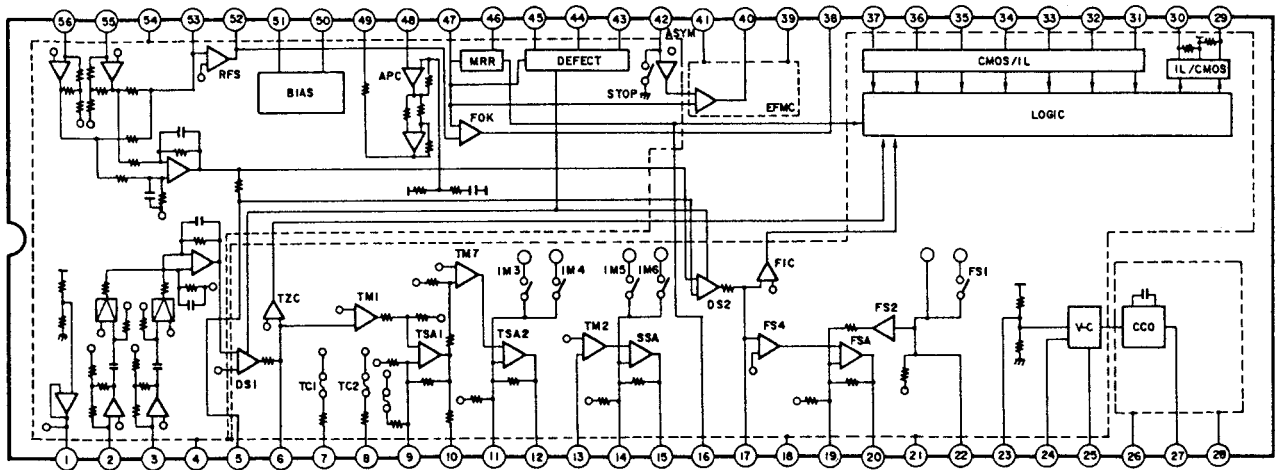
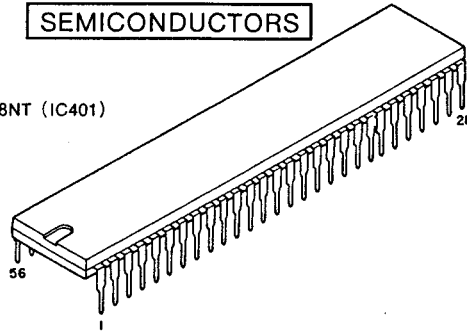

● Pin function table

Pin No.	Symbol	I/O	Function	Pin No.	Symbol	I/O	Function
1	VREF	O	Reference voltage output	29	COUT	O	Track count signal output
2	TR1	I	TR1 (I/V conversion amplifier) input	30	SENS	O	FZC and TZA signal output
3	TR2	I	TR2 (I/V conversion amplifier) input	31	XRST	I	Reset signal output
4	PG	GND	Preamplifier block ground	32	DIRC	I	Direct control signal output
5	FH	O	Focus error hold signal output	33	XLT	I	Data transfer signal input
6	TE	I/O	Track error signal output, TM1 input	34	DATA	I	Data signal input
7	TG1	I	TG1 switch	35	CLK	I	Data sync clock input
8	TG2	I	TG2 switch	36	LMSW	I	Limit switch input
9	TS1 \ominus	I	TSA1 \ominus input	37	LDSW	I	Laser switch input
10	TS10	O	TSA1 output	38	FOK	O	FOK comparator output
11	TS2 \ominus	I	TSA2 \ominus input	39	GEFM	GND	EFM comparator ground
12	TS20	O	TSA2 output	40	EFMC	O	EFM comparator output
13	TM2	I	TM2 input	41	VEFM	Vcc	EFM comparator Vcc
14	SS \ominus	I	SSA \ominus input	42	DSLCL	I	Data slice level control input
15	SSO	O	SSA output	43	DFIN	I	Defect comparator input
16	MIRR	O	Mirror comparator output	44	DFO	O	Defect signal output
17	FE	I/O	Focus error signal output, FS4 input	45	DFH	O	Defect hold signal output
18	SG	GND	Servo block ground	46	MIRH	O	Error hold signal output
19	FS \ominus	I	SSA \ominus input	47	EFMI	I	EFM signal output
20	FS0	O	FSA input	48	MD	I	APC amplifier input
21	SVCC	Vcc	Servo block Vcc	49	LD	O	APC amplifier output
22	FUD	O	Focus up/down voltage output	50	BVPS	O	Capacitor connection pin for ripple filter
23	VCR	I/O	VCO reference voltage	51	ISET	O	Reference current setting
24	PDIN	I	VCO control voltage input	52	RFO	O	RFS output
25	FRA	O	VCO free-run frequency setting	53	RF \ominus	I	RFS \ominus input
26	VVcc	Vcc	VCO Vcc	54	PVcc	Vcc	Pre-block Vcc
27	VCO	O	VCO output	55	RF1	I	RF1 (I/V conversion block) input
28	VGND	GND	VCO ground	56	RF2	I	RF2 (I/V conversion block) input

CD SECTION

SM5840CP (IC201)

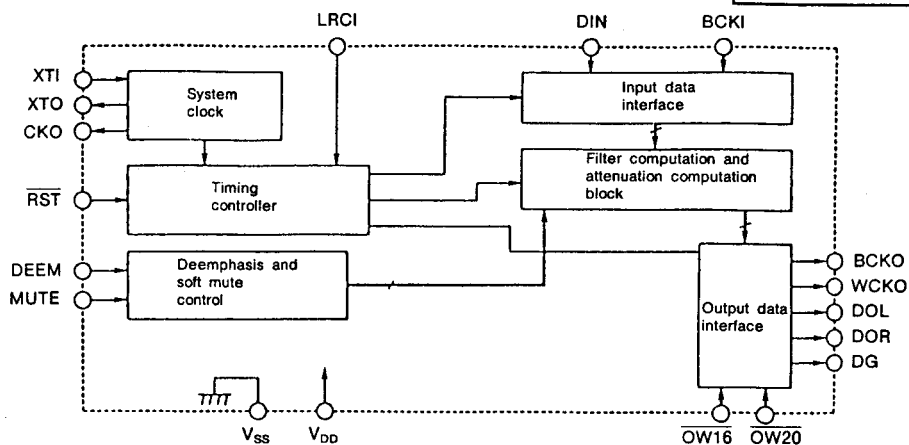
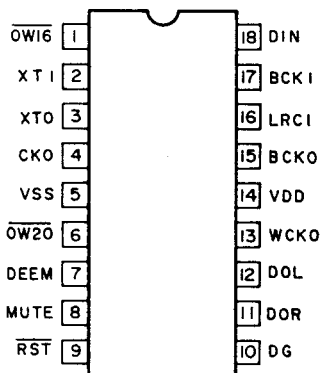
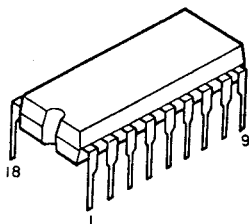

● Pin Description

Pin number DIP	Pin name	i/o	Function			
			Setting	OW20		
				H	L	
1	OW16	ip	Selection pin 1 for number of output bits (NOTE) NS-ON : Noise shaper on NS-OFF : Noise shaper off	OW16	H 18bit output (NS-ON)	L 20bit output (NS-ON)
2	XT1	i	Oscillator input pin			
3	XTO	o	Oscillator input pin			
4	CKO	o	Oscillator output clock (Frequency is the same as XT1)			
5	Vss	-	Ground pin			
	(N.C.)					
	(N.C.)					
6	OW20	ip	Selection pin 2 for number of output bits (NOTE) See the column of OW16.	(When OW20 is low level : 18 bits or 20 bits) (When OW20 is high level : 18 bits or 16 bits)		
7	DEEM	ip	Deemphasis signal input	(When DEM is low level : Deemphasis is off) (When DEM is high level : Deemphasis is on)		
8	MUTE	ip	Mute signal input	(When MUTE is low level : Soft mute is off) (When MUTE is high level : Soft mute is on)		
9	RST	ip	System reset (Initialization)			
10	DG	o	Degitch output			
11	DOR	o	Right channel data output			
12	DOL	o	Left channel data output			
13	WCKO	o	Output word clock			
14	VDD	-	Supply pin (5 V : Standard)			
	(N.C.)					
	(N.C.)					
15	BCKO	o	Output bit clock			
16	LRCI	ip	Clock of the input data sample rate (fs)			
17	BCKI	ip	Input bit clock			
18	DIN	ip	Input data			

i : Input pin ip : Input pin with pull-up resistor o : Output pin

BA15218, RC4558
(IC205, 206, 301)

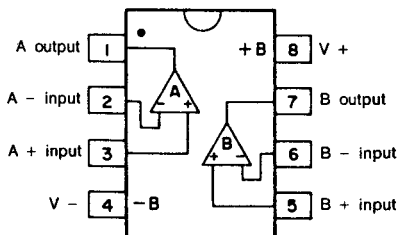
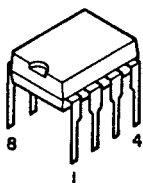

CD SECTION

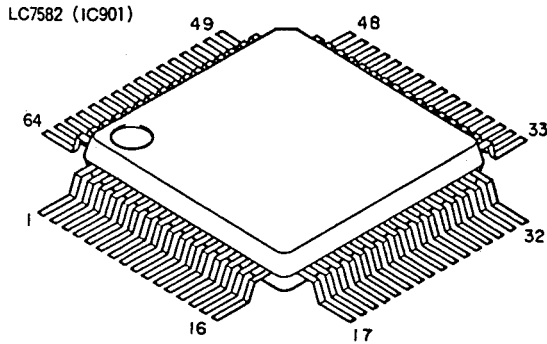

Pin Configuration

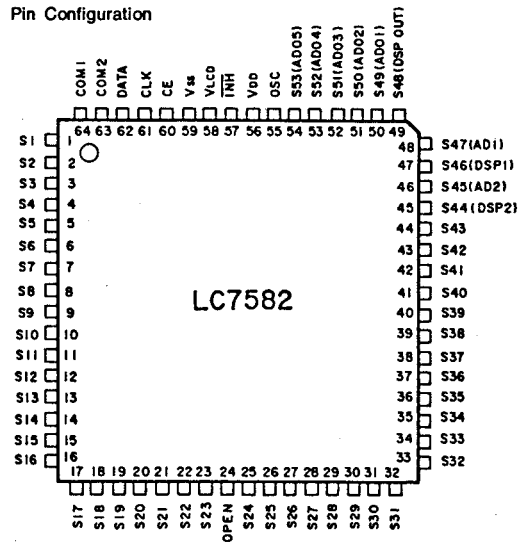

Block Diagram

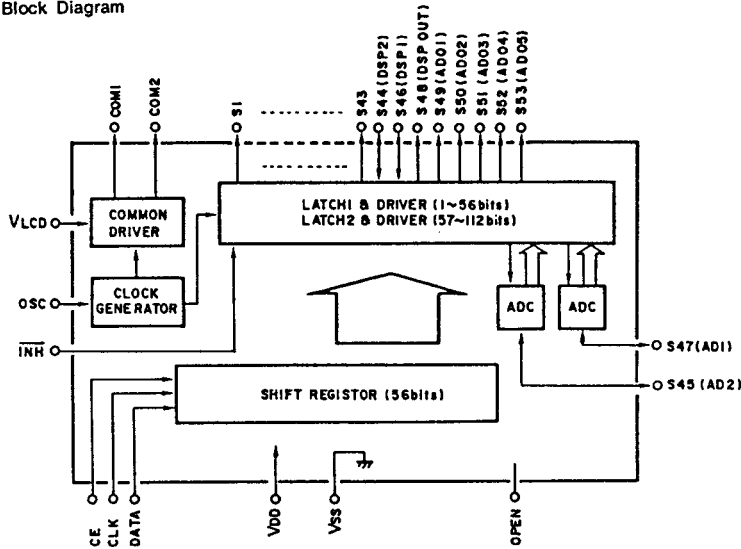

Pin Description

- S1~S13 : Segment output pins
- S46 (DSP1), S44 (DSP2) : Segment output or DSP input pins
- S47 (AD1), S45 (AD2) : Segment output or AD input pins
- S48 (DSP OUT) : Segment output or DSP output pins
- S49~S53 (AD01~5) : Segment output or AD output pins
- COM1,2 : Common output pins (At 1/1 duty, only COM1 is used and COM2 is open)
- V_{lcd} : Pin for LCD bias voltage setting
- OSC : Oscillation pin
- CE, CLK, DATA : Input pins for serial data transfer
- V_{ss}, V_{DD} : Supply pins
- INH : Display-off input pin (Valid only with the output driver. As a result, the transfer of serial data is possible while the display is off.)
- OPEN : No connection

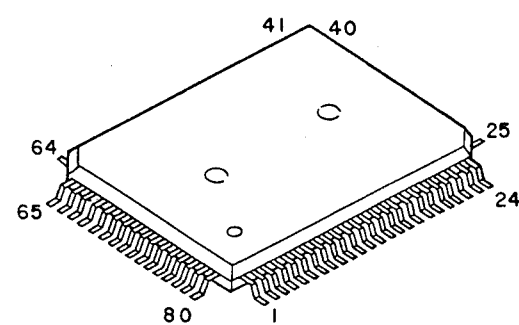

CXD2500AQ (IC701)

● CXD2500AQ Pin Function Table

Pin no.	Pin symbol	I/O	Pin description
1	FOK	I	Focus OK input pin. Used in SENS output and the servo auto sequencer.
2	FSW	O	Z.0 Output filter switching output of the spindle motor.
3	MON	O	1.0 On-off control output of the spindle motor.
4	MDP	O	1,Z.0 Servo control of the spindle motor.
5	MDS	O	1,Z.0 Servo control of the spindle motor.
6	LOCK	O	1.0 Samples GFS at 460 Hz. When GFS is "H", H is output. L is output when there is "L", 8 times in succession.
7	NC	—	
8	VCOO	O	1.0 Oscillation circuit output for analog EFM PLL.
9	VCOI	I	Oscillation circuit output for analog EFM PLL. $f_{LOCK} = 8.6436$ MHz.
10	TEST	I	Test pin, always grounded.
11	PDO	O	1,Z.0 For charge pump used with analog EFM PLL.
12	Vss		Ground
13	NC	—	
14	NC	—	
15	NC	—	
16	VPCO	O	1,Z.0 PLL charge pump output used for vari-pitch.
17	VCKI	O	Clock input f_{CENTER} from the external VCO for varipitch equals 16.9344 MHz.
18	FILO	O	Analog Filter output (slave = digital PLL) for master PLL.
19	FILI	I	Filter input for master PLL.
20	PCO	O	1,Z.0 Charge pump output for master PLL.
21	AVss		Analog ground.
22	CLTV	I	VCO control voltage input for master.
23	AVDD		Analog supply (+5 V)
24	RF	I	EFM signal input
25	BIAS	I	Grounded
26	ASYI	I	Grounded
27	ASYO	O	1.0 EFM full-swing output. (L = Vss, H = VDD)
28	ASYE	I	Grounded
29	NC	—	
30	PSSL	I	Switching input for the audio data output mode. Serial output with "L" and parallel output with "H".
31	WDCK	O	1.0 D/A interface for 48-bit slot. Word clock $f = 2Fs$.
32	LRCK	O	1.0 D/A interface for 48-bit slot. LR clock $f = Fs$.
33	VDD		Supply (+5 V)

Pin no.	Pin symbol	I/O	Pin description
34	DA16	O	1.0 DA16 (MSB) output when PSSL = 1. Serial data of the 48-bit slot when PSSL = 0. (2s' COMP, MSB first.)
35	DA15	O	1.0 DA15 output when PSSL = 1. Bit clock of the 48-bit slot when PSSL = 0.
36	DA14	O	1.0 DA14 output when PSSL = 1. Serial data of the 64-bit slot when PSSL = 0. (2s' COMP, LSB first.)
37	DA13	O	1.0 DA13 output when PSSL = 1. Bit clock of the 64-bit slot when PSSL = 0.
38	DA12	O	1.0 DA12 output when PSSL = 1. LR clock of the 64-bit slot when PSSL = 0.
39	DA11	O	1.0 DA11 output when PSSL = 1. GTO output when PSSL = 0.
40	DA10	O	1.0 DA10 output when PSSL = 1. XUGF output when PSSL = 0.
41	DA09	O	1.0 DA09 output when PSSL = 1. XPLCK output when PSSL = 0.
42	DA08	O	1.0 DA08 output when PSSL = 1. GFS output when PSSL = 0.
43	DA07	O	1.0 DA07 output when PSSL = 1. RFCK output when PSSL = 0.
44	DA06	O	1.0 DA06 output when PSSL = 1. C2PO output when PSSL = 0.
45	DA05	O	1.0 DA05 output when PSSL = 1. XRAOF output when PSSL = 0.
46	DA04	O	1.0 DA04 output when PSSL = 1. MNT3 output when PSSL = 0.
47	DA03	O	1.0 DA03 output when PSSL = 1. MNT2 output when PSSL = 0.
48	DA02	O	1.0 DA02 output when PSSL = 1. MNT1 output when PSSL = 0.
49	DA01	O	1.0 DA01 output when PSSL = 1. MNT0 output when PSSL = 0.
50	APTR	O	1.0 Control output for aperture correction. "H" with Rch.
51	APTL	O	1.0 Control output for aperture correction. "H" with Lch.
52	Vss		Ground
53	XTAI	I	16.9344 MHz x'tal oscillator circuit input. Or 33.8688 MHz input.
54	XTAO	O	1.0 16.9344 MHz x'tal oscillator circuit input.
55	XTSL	I	X'tal selection input pin. "L" when the x'tal is 16.9344 MHz and "H" when the x'tal is 33.8688 MHz.
56	FSTT	O	1.0 2/3 frequency division output of pins 53 and 54. Does not change with vari-pitch.
57	C4M	O	1.0 4.2336 MHz output. Changes simultaneously when varypitch is applied.
58	C16M	O	1.0 16.9344 MHz output. Changes simultaneously when varypitch is applied.
59	MD2	I	Digital-Out on/off control. H when on and L when off.
60	DOUT	O	1.0 Digital-out output pin.
61	EMPH	O	1.0 When the playback disc has emphasis. "H" is output. "L" is output when there is no emphasis.
62	WFCK	O	1.0 WFCK (Write Frame Clock) output.
63	SCOR	O	1.0 "H" output when either sub code sync S0 or S1 is detected.
64	SBSO	O	1.0 Sub P through W serial output.
65	EXCK	I	Clock input for SBSO read-out use.
66	SQSO	O	1.0 SubQ 80 bit and PCM peak level data 16-bit output.
67	SQCK	I	Clock input for SQSO read-out use.
68	MUTE	I	Mute L is cancelled with H.
69	SENS	—	1,Z.0 SENS output. Output to CPU.
70	XRST	I	System set. Reset with "L".
71	DATA	I	Serial data input from CPU.
72	XLAT	I	Latch input from CPU. Latches serial data on the fall.
73	VDD		Supply (+5 V)
74	CLOK	I	Serial data transfer clock input from CPU.
75	SEIN	I	Sense input from SSP.
76	CNIN	O	Count signal input of number of track jumps.
77	DATO	O	Serial data output to SSP.
78	XLTO	O	1.0 Serial data latch output to SSP. Latches on the fall.
79	CLKO	O	1.0 Serial data transfer clock output to SSP.
80	MIRR	I	Mirror signal input. Used in jumps of 128 tracks or more with an auto sequencer.

CD SECTION

μPD75116GF-E16-3BE (IC601)

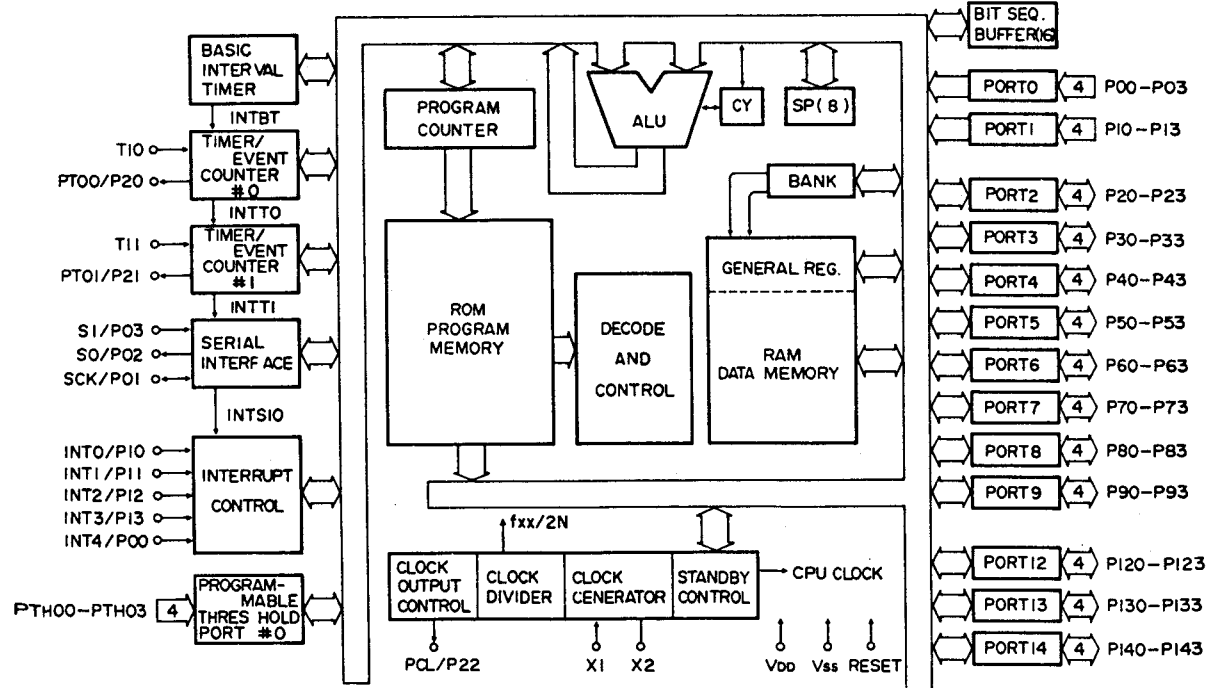
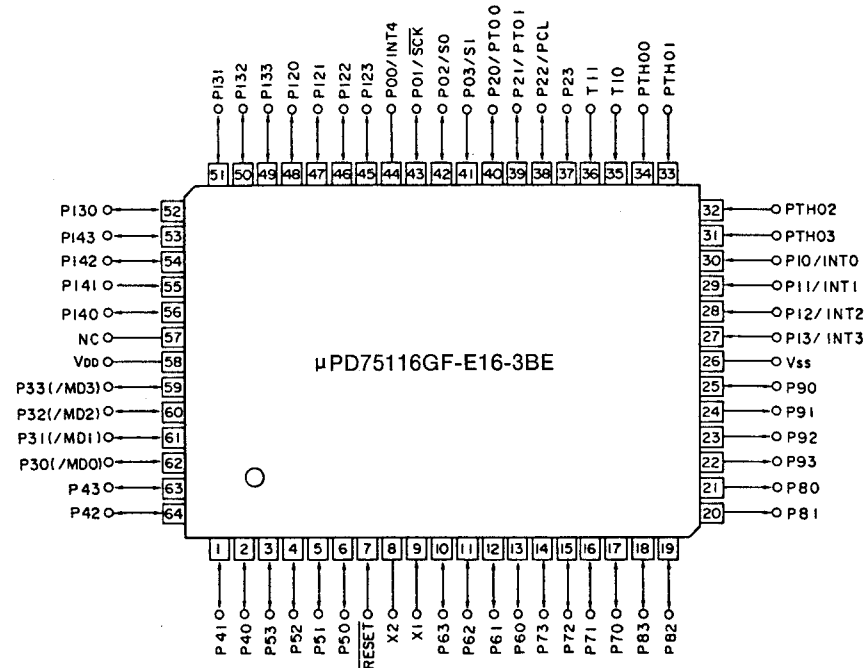
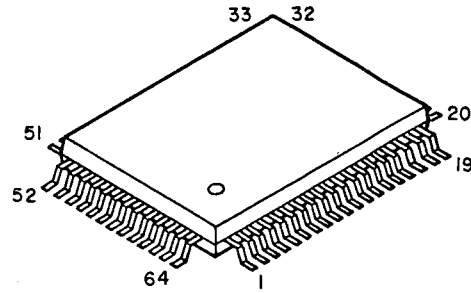

Pin	Pin name	Signal name	I/O	Active	Initial	Description	Pin	Pin name	Signal name	I/O	Active	Initial	Description
1	P41	NC	O	—	L	Open	33	PTH01	PKR3	I	H	L	Key return
2	P40	POSPRES	O	H	L	Reset signal (10 ms) (with vary on) for DPS	34	PTH00	PKR4	I	H	L	Key return
3	P53	NC	O	—	L	Open	35	T10	PSENSE	I	—	H	Servo state detection signal
4	P52	NC	O	—	L	Open	36	T11	NC	I	—	H	Ground
5	P51	PS9	O	H	L	Diode key scan signal	37	P23	PSVCDAT	O	—	H	Servo control signal and data for D.F.
6	P50	PS8	O	H	L	Momentary key scan signal 8	38	P22/PCL	PSVCLT	O	LP	H	Servo control signal latch.
7	RESET	RESET	I			Microprocessor reset pin.	39	P21/PT01	PSVCLK	O	—	H	Servo control signal and clock for D.F.
8	X2	μCONCLK	O			Microprocessor clock	40	P20/PT00	PLASER	O	L	H	Laser diode on/off control.
9	X1	μCONCLK	I			Microprocessor clock	41	P03/SI	PSUBQ	I	—	H	Sub code data input.
10	P63	PKS7	O	H	L	Momentary key scan signal 7	42	P02/SO	NC	O	—	—	Open
11	P62	PKS6	O	H	L	Momentary key scan signal 6	43	P01/SCK	PSQCK	O	—	H	Clock for sub code reading.
12	P61	PKS5	O	H	L	Momentary key scan signal 5	44	P00/INT4	PREM	I	↑↓	L	Remote control signal input.
13	P60	PKS4	O	H	L	Momentary key scan signal 4	45	P123	PDFLT	O	LP	H	Latch signal for digital filter.
14	P73	PKS3	O	H	L	Momentary key scan signal 3	46	P122	PAMUT	O	H	H	Audio mute control signal.
15	P72	PKS2	O	H	L	Momentary key scan signal 2	47	P121	PEMP	O	L	H	Signal with emphasis control.
16	P71	PKS1	O	H	L	Momentary key scan signal 1	48	P120	PDIRC	O	LP	H	Servo control signal.
17	P70	PKS0	O	H	L	Momentary key scan signal 0	49	P133	PMVCL	O	L	H	Disc tray drive signal.
18	P83	NC	O	—	L	Open	50	P132	PMVOP	O	L	H	Disc tray drive signal.
19	P82	NC	O	—	L	Open	51	P131	PDMUT	O	H	H	Mute output for LSI.
20	P81	NC	O	—	L	Open	52	P130	PAFSO	O	—	H	Auto function serial output.
21	P80	NC	O	—	L	Open	53	P143	PFOK	I	H	L	FOCUS OK signal input.
22	P93	PTINIT	O	H	L	Test pin	54	P142	PSWOPN	I	L	H	Disc tray open position detection.
23	P92	PTEDIT	O	H	L	Test pin	55	P141	PSWCLS	I	L	L	Disc tray close position detection.
24	P91	PTSARCH	O	H	L	Test pin	56	P140	PSWPMI	I	L	—	Pickup inner track position detection.
25	P90	PDOUT	O	H	L	Digital output control signal	57	NC	NC				Open
26	Vss	Vss				Ground potential pin	58	Vdd	Vdd				Positive voltage supply pin. (+5 V)
27	P13/INT3	NC	I	—	H	Pull-up	59	P33	PLCDOF	O	L	L	Display-off output signal for LCD driver.
28	P12/INT2	PGFS	I	H	L	Rotation sync signal input from DPS.	60	P32	PLCDCE	O	H	L	Latch signal for LCD driver.
29	P11/INT1	PSCOR	I	↑↓	L	Sub code sync signal input.	61	P31	PLCDCLK	O	—	L	Clock for LCD driver.
30	P10/INT0	PAFSI	I	—	H	Auto function real signal input.	62	P30	NC	O	—	L	Open
31	PTH03	PKR1	I	H	L	Key return	63	P43	NC	O	—	L	Open
32	PTH02	PKR2	I	H	L	Key return	64	P42	PLCDDAT	O	—	L	Data for LCD driver.

LP = LOW pulse

PCM61P-L (IC203, 204)

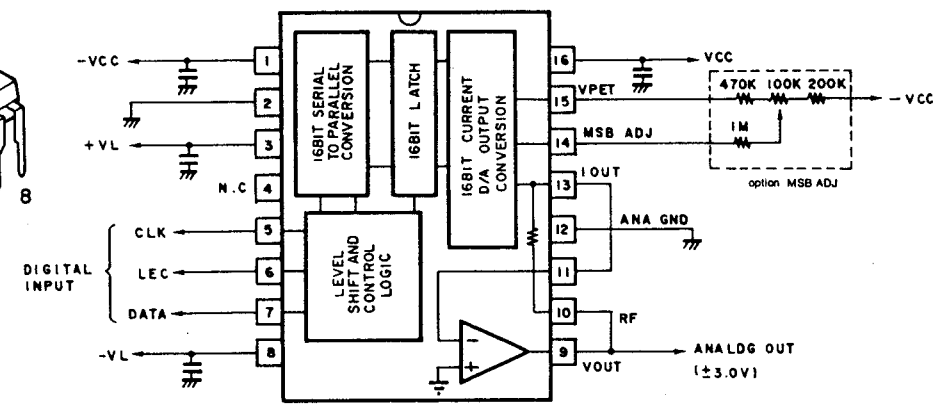
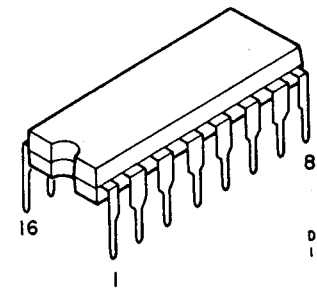

BA6290A (IC402, 403)

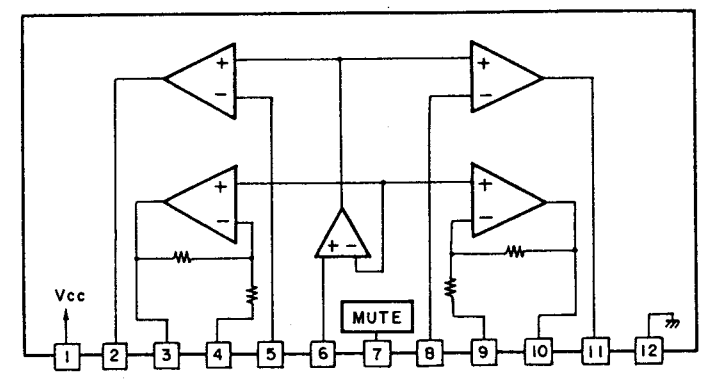
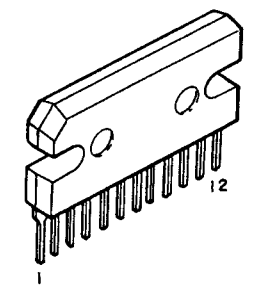

M5290P (IC503)

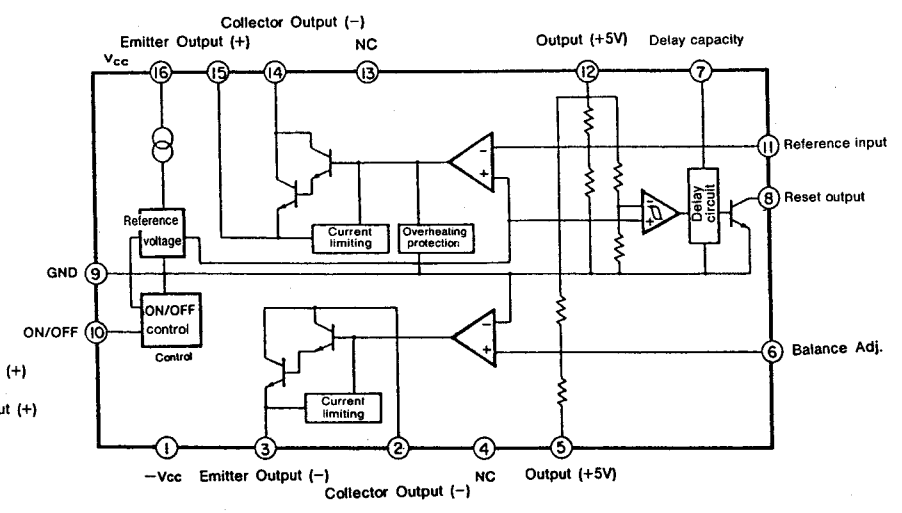
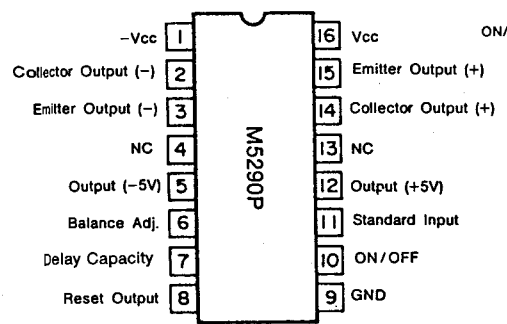
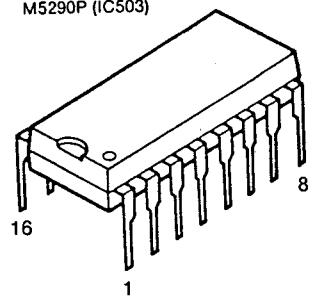

IC PROTECTOR ICP-N15 (IC501, 502)

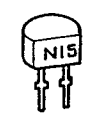

● Transistors

2SA1015 (GR)

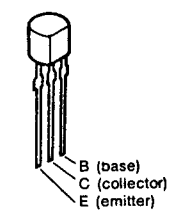

DTA114ES PNP Type
DTC114ES } NPN Type
DTC144ES

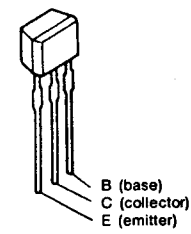

2SD562 (C), BC369
2SD468 (C), BC368

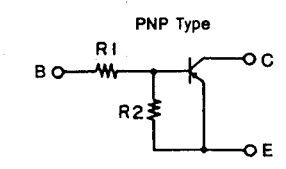
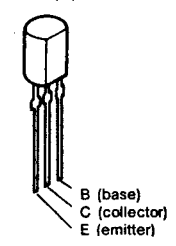

	R1	R2
DTA114ES	10k ohm	10k ohm

2SB1274
2SD1913

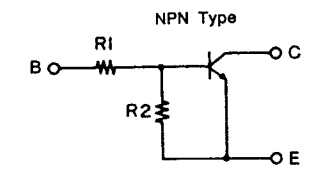
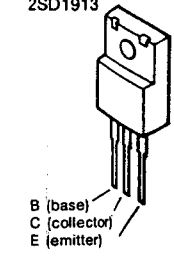

	R1	R2
DTC114ES	10k ohm	10k ohm
DTC144ES	47k ohm	47k ohm
DTC314TS	10k ohm	-

● Diodes (included LED)

1SS270A



1SR139-200

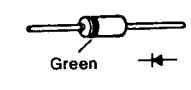

DTC314TS

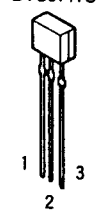

(1) Emitter E
(2) Collector C
(3) Base B

HZS6B-2

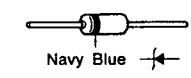

SLR-34MC70F120G (Green)

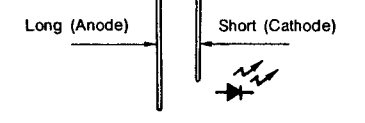
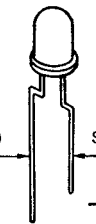

● LED Ass'y

Part No.: 3939493002 (LE901)

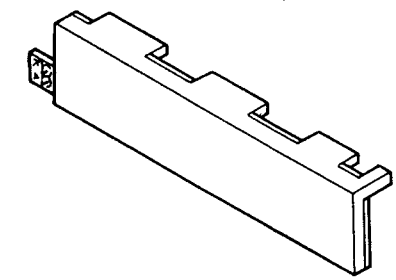

● Wiring Diagram

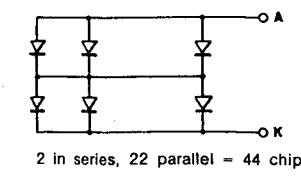

CD SECTION

● LCD Ass'y (8155JPH)
Part No.: 3934105007

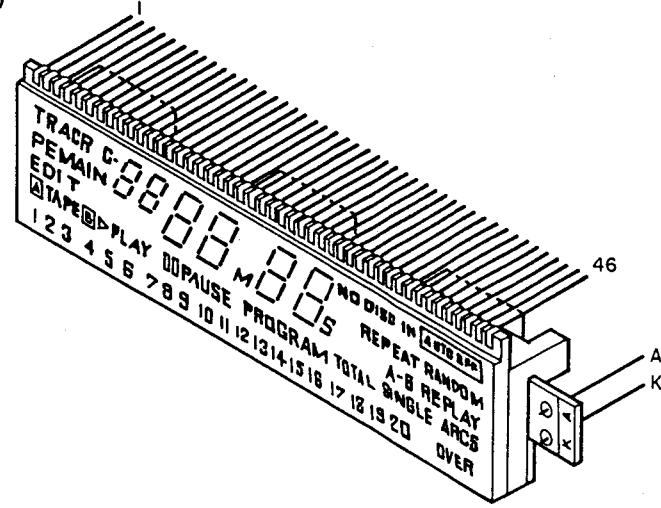

TRACK C- 0000 NO DISC IN AUTO OFF
 REMAIN 00:00 M 00 S REPEAT RANDOM
 EDIT A-B REPLAY
 [A] TAPE [B] ▷ PLAY [] PAUSE PROGRAM TOTAL SINGLE ARCS
 1 2 3 4 5 6 7 8 9 10 11 12 13 14 15 16 17 18 19 20 OVER

NO.	1	2	3	4	5	6	7	8	9	10	11	12	13	14	15	16	17	18	19	20	21	22	23
COM1	-	COM	6	PAUSE	4	B	2	TRACK	A	C-	1f	1a	1b	2d	2a	2g	3d	3e	3a	3b	4e	4f	4b
COM2	COM	-	5	PLAY	3	TAPE	1	REMAIN	EDIT	1d	1e	1g	1c	2e	2f	2b	2c	3f	3g	3c	4d	4a	4g
NO.	24	25	26	27	28	29	30	31	32	33	34	35	36	37	38	39	40	41	42	43	44	45	46
COM1	M	TOTAL	5e	5f	5a	5c	6f	6a	6b	17	B	DISC	IN	SINGLE	ARCS	RANDOM	AUTO	20	16	14	12	10	8
COM2	4c	PROGRAM	5d	5g	5b	6d	6e	6g	6c	S	A-	NO	REPEAT	18	OVER	REPLAY	OFF	19	15	13	11	9	7

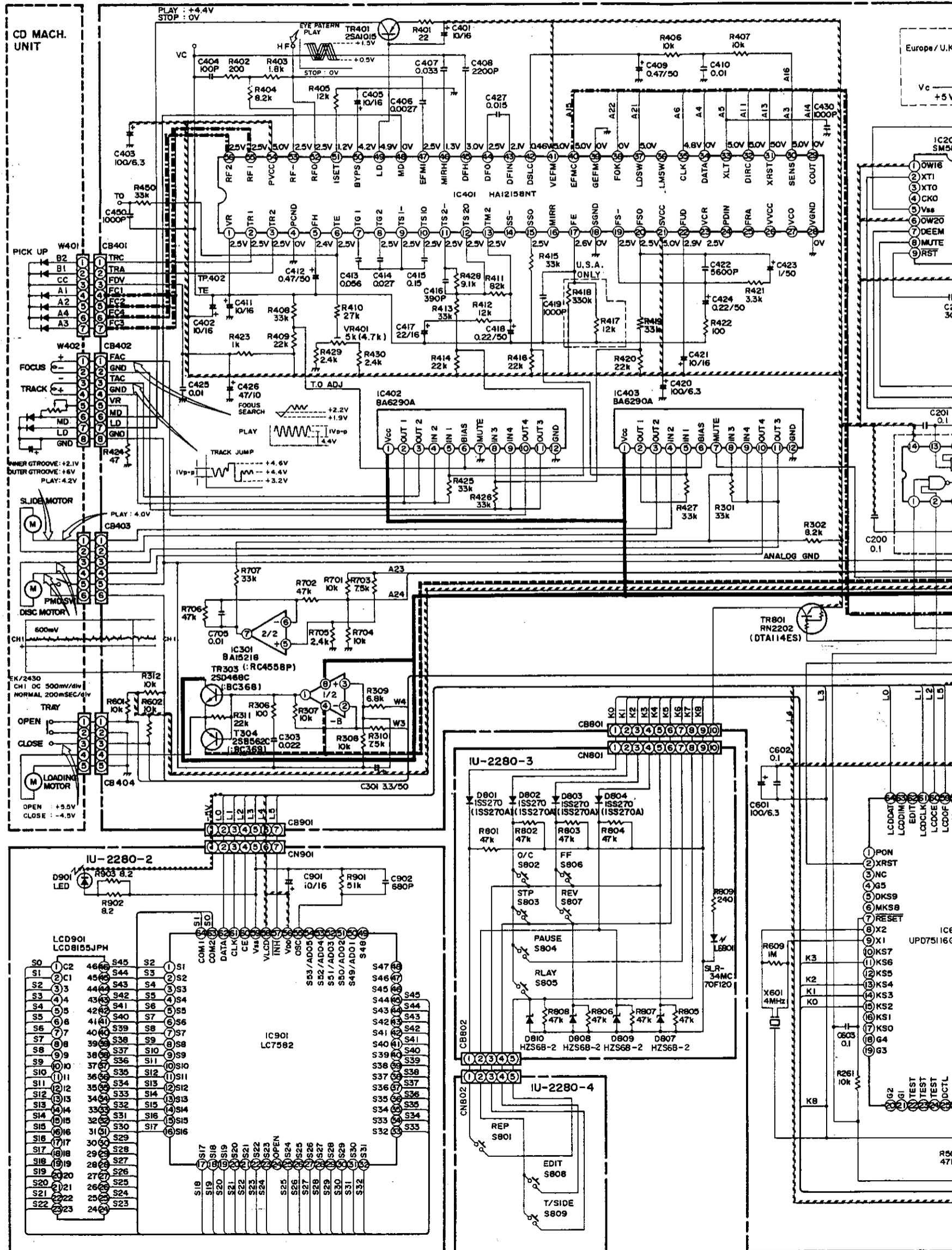

NOTE: Figures in parentheses are for the UCD-70 Europe/BK.

SCHEMATIC DIAGRAM

5 6 7 8 9 10

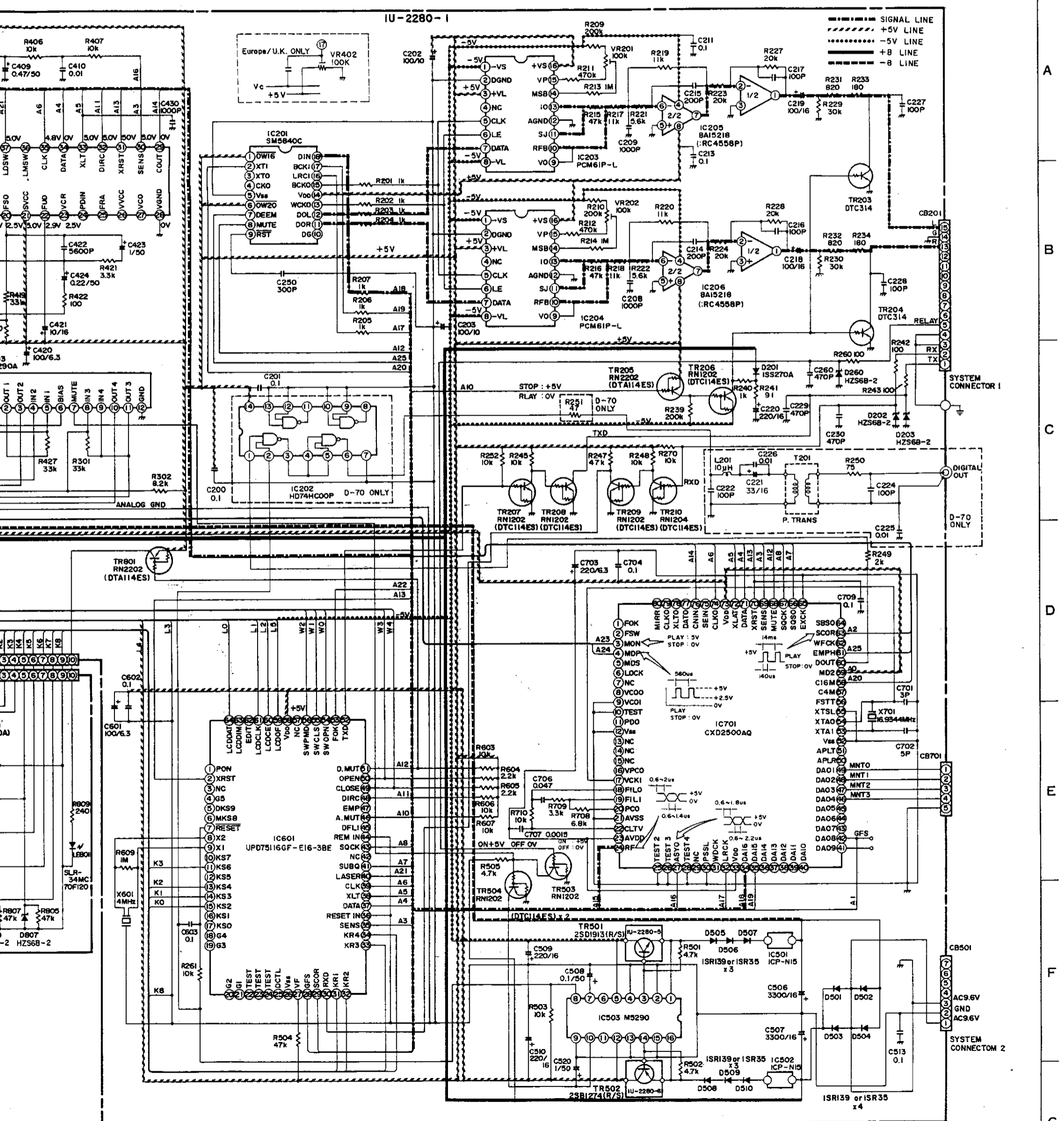

NOTES
 ALL RESISTANCE VALUES IN OHM K=1,000 OHM M=1,000,000 OHM
 ALL CAPACITANCE VALUES IN MICRO FARAD P=MICRO-MICRO FARAD
 EACH VOLTAGE AND CURRENT ARE MEASURED AT NO SIGNAL INPUT CONDITION.
 CIRCUIT AND PARTS ARE SUBJECT TO CHANGE WITHOUT PRIOR NOTICE.

CD SECTION

EXPLODED VIEW OF PARTS LIST

Ref. No.	Part No.	Part Name	Remarks	Qty
1	411 1099 139	Chassis		1
2	105 0973 225	Rear Panel		1
3	104 0253 010	Foot Ass'y		4
4	415 9016 019	P.C.B Holder		2
5	-	-		-
6	1U- 2280 A	CD Unit Ass'y		1 ^s
6-1	-	Main Unit		(1)
6-2	-	LCD Unit		(1)
6-3	-	Tact Switch Unit		(1)
6-4	-	Tact Switch Unit		(1)
7	-	-		-
8	393 4105 007	LCD Ass'y	LC901	1
9	254 4255 704	Chemicon 3300 μ F/16V	C506.507	2
10	337 0015 007	CD Mech. Unit		1
11	103 1469 101	Mech.Holder (A)		3
12	146. 1283 216	Loader Panel (C) Ass'y		1
13	144 2134 041	Front Panel		1
14	103 1471 335	Inner Panel Ass'y		1
15	435 0113 009	Latch (Y3Y18)		1
16	143 0742 102	Lens		1
17	113 1458 119	Control Button		1
18	144 2133 110	Trap Door		1
19	401 0126 200	Door Hinge (L)		1
20	401 0127 209	Door Hinge (R)		1
21	146 1279 110	Side Panel (L) Ass'y		1
22	146 1281 111	Side Panel (R) Ass'y		1
23	102 0478 132	Top Cover		1
24	513 1863 056	Rating Sheet		1
25	262 1456 206	μ PD75116GF-E16-3BE	μ -Com	1
26	449 0055 302	LCD Holder		1
27	204 2429 003	7P System Socket	CB501	1
28	204 8284 022	15P System Socket	CB201	1
29	122 0146 002	Himeron Sheet	Put on F/Panel	1
★ 30	513 1513 005	Laser Caution	Europe model only	1
★ 31	513 0985 003	Inst. Label	Europe model only	2
★ 32	461 0577 068	Rubber Sheet		1
SCREWS				
71	473 7002 034	Tapping Screw (S) 3X6	Black	19
72	473 7500 015	Tapping Screw (P) 3X8		6
73	473 7002 021	Tapping Screw (S) 3X8	Black	2
74	473 7007 000	Tapping Screw (S) 4X8	Black	4
76	473 7500 044	Tapping Screw (P) 3X8	Black	2
77	473 7015 018	Tapping Screw (S) 3X8	Black for GND	1
78	425 0232 006	Adjust Washer	t0.3 Black	1
79	425 0232 019	Adjust Washer	t0.5 Clear	1
PACKING & ACCESSORIES (Not included EXPLODED VIEW)				
101	505 0154 082	Cabinet Cover	600X600	1
102	-	-		-
103	503 0980 001	Cushion		2
104	501 1560 013	Sleeve Carton		1
105	GEN 1785	Envelope Sub Ass'y		1 ^s
105-1	505 0178 000	:Poly Cover	255X380	(1)
105-2	511 2224 009	Inst. Manual		(1)
105-3	511 2264 001	Inst. Manual (3)		(1)
106	GEN 1789	Acc. Carton Sub Ass'y		1 ^s
106-1	501 9195 008	Accessory Carton		(1)
106-2	231 0922 009	Loop Antena		(1)
106-3	395 0019 025	FM Ant. Ass'y		(1)
106-4	529 0072 005	FM AntAdaptor		(1)
106-5	399 0144 002	Remote Control	RC-142	(1)
106-6	204 2483 007	7P System Connector Cord		(1)
106-7	204 6318 013	15P System Connector Cord		(1)
107	513 1389 006	Control Card Base		1
108	513 1349 004	Thermal Carbon Film		1

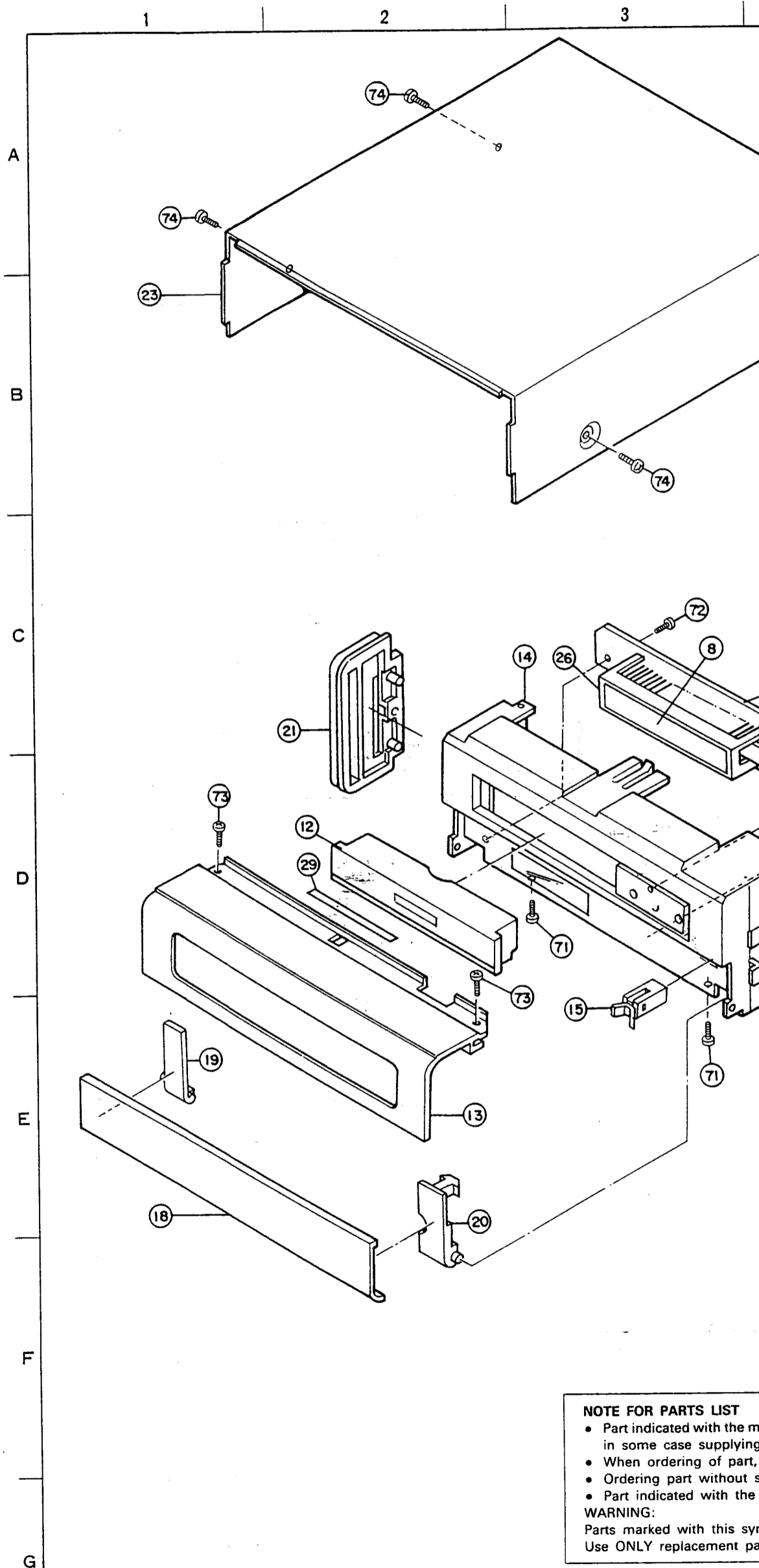

NOTE FOR PARTS LIST

- Part indicated with the m
 - in some case supplying
 - When ordering of part,
 - Ordering part without s
 - Part indicated with the
- WARNING:**
Parts marked with this sym
Use ONLY replacement pa

EXPLODED VIEW

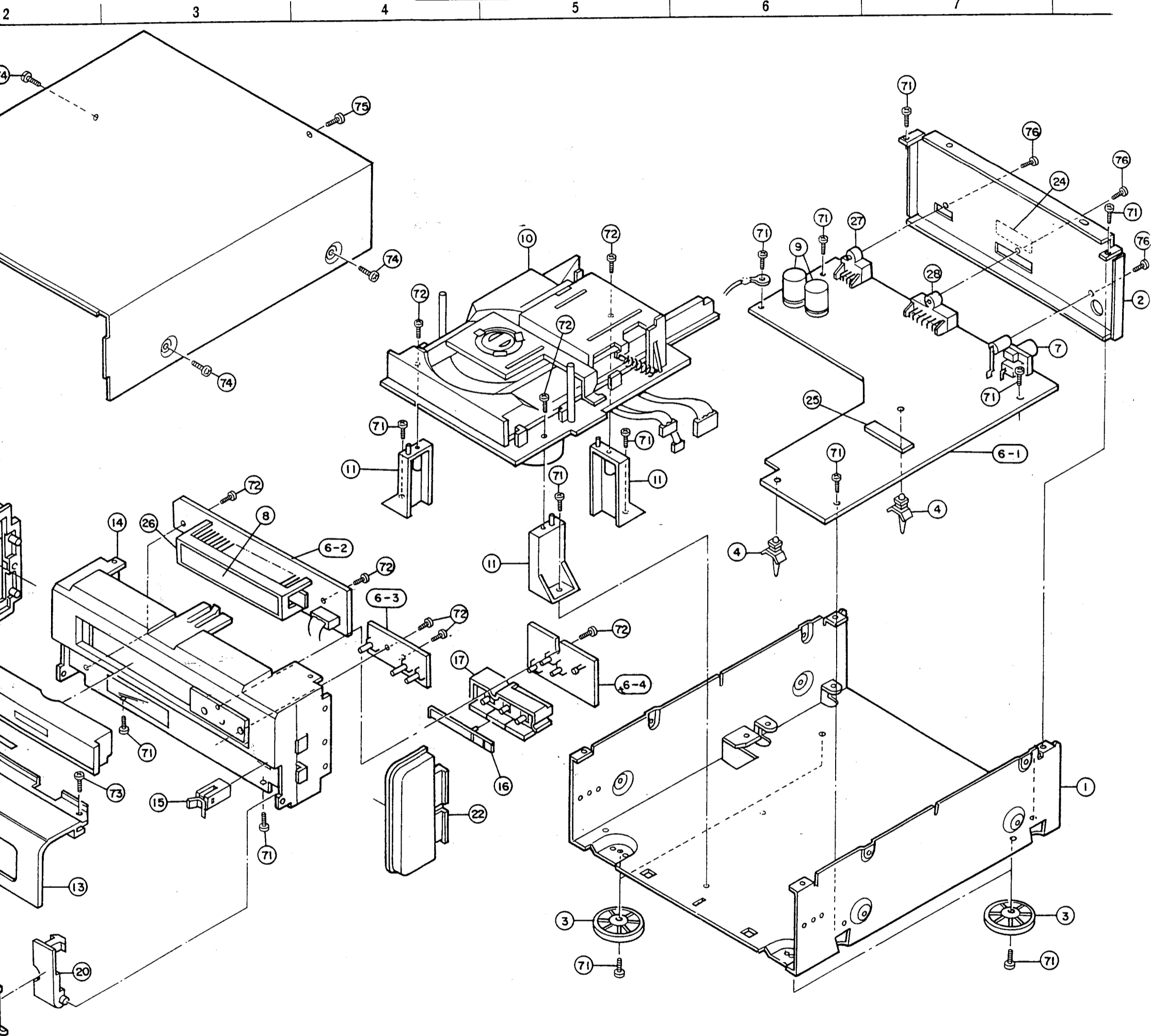

NOTE FOR PARTS LIST

- Part indicated with the mark "⊙" are not always in stock and possibly to take a long period of time for supplying, or in some case supplying of part may be refused.
- When ordering of part, clearly indicate "1" and "1" (i) to avoid mis-supplying.
- Ordering part without stating its part number can not be supplied.
- Part indicated with the mark "★" is not illustrated in the exploded view.

WARNING:

Parts marked with this symbol Δ  have critical characteristics. Use ONLY replacement parts recommended by the manufacturer.

CD SECTION

DISASSEMBLY OF CD MECHANISM

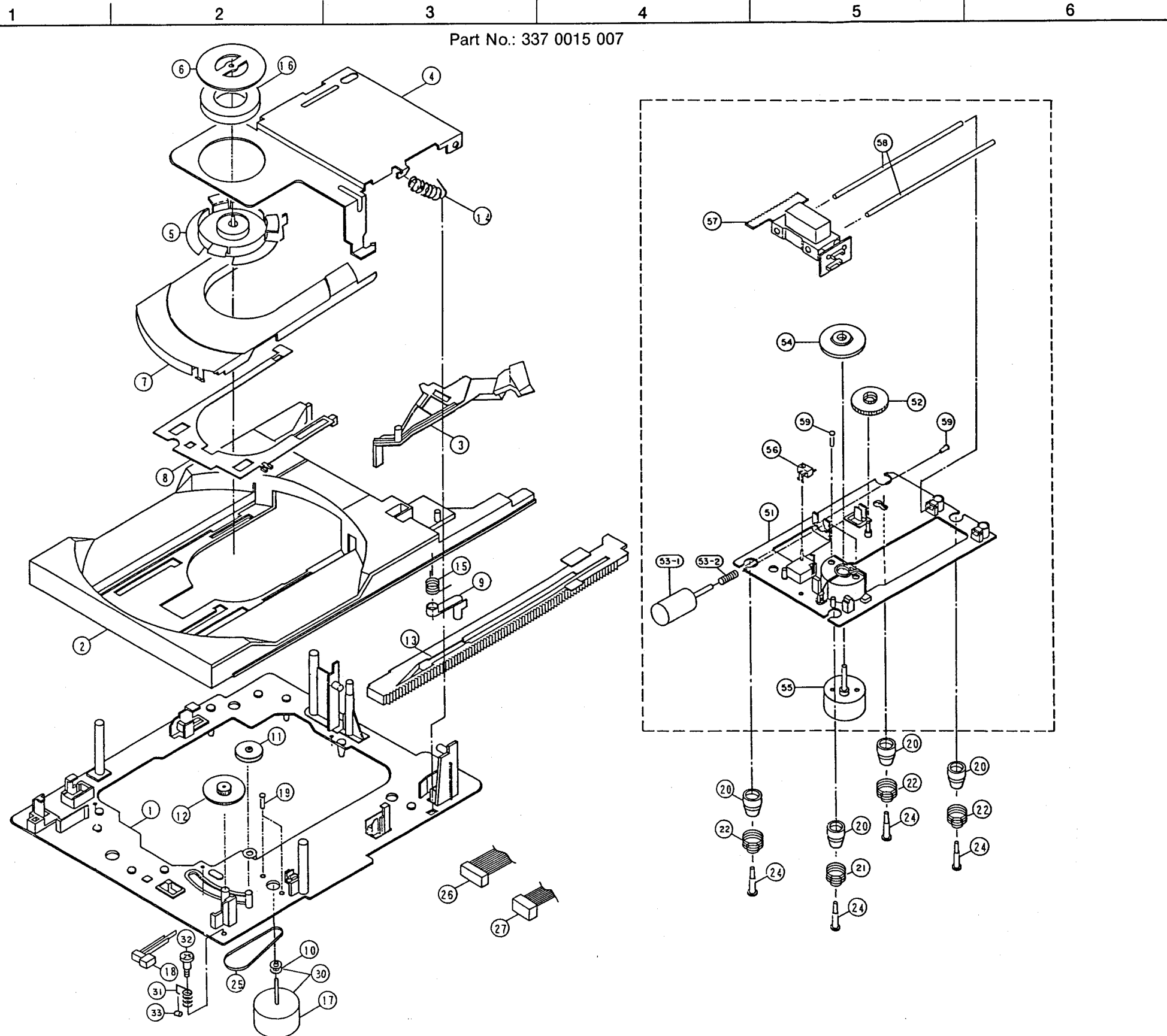

CD MECH. EXPLODED VIEW OF PARTS LIST : 337 0015 007

Ref. No.	Part No.	Part Name	Remarks	Qty
1	9KA 81A2 95	Loading Plate OS		1
2	9KA 81G9 73	Tray 201		1
3	9KA 81G9 74	Switch Lever		1
4	9KA 81P4 62	Clamper Arm		1
5	9KA 81G9 75	Clamper		1
6	9KA 81P4 63	Clamper Plate		1
7	9KA 81G9 76	Disc Holder		1
8	9KA 81G9 77	Lifter Cam		1
9	9KA 81G9 78	Latch		1
10	-	Motor Pulley		1
11	9KA 81G1 22	Pulley Gear		1
12	9KA 81G1 23	Gear		1
13	9KA 81G5 81	Rack 11B		1
14	9KA 81S0 59	Clamp Spring		1
15	9KA 81S0 60	Latch Spring		1
16	9KA 82G0 57	Clamper Magnet		1
17	-	Motor MDN-4RA3EZAS		1
18	9KS 01W1 32	Leaf Switch SWL5C122343AU	Loading Limit Switch SW	1
19	9KM 20S0 04	M2X4 Screw		2
20	9KA 82G0 56	Floating Rubber M3		4
21	9KA 81S0 66	Floating Spring SPM3A		1
22	9KA 81S0 67	Floating Spring SIM3B		3
23	-	-		-
24	9KA 81H0 85	Floating Screw C		4
25	9KA 82G1 80	Floating Belt (Square)	1.4X18.1	1
26	9KA 82G1 23	Connector Wire 6P	CNW6PM3	1
27	9KA 82G1 24	Connector Wire 5P	CNW5PM3	1
28	-	-		-
29	-	-		-
30	9KA 81A3 08	Loading Motor Ass'y	with 10, 17	1
31	9KA 81S0 71	Tray Spring		1
32	9KA 82H0 35	Tray Spring Fixing Screw		1
33	9KA 82G1 84	Tube		1
51	9KA 81A2 93	Spindle Motor Ass'y	Includ T/M, Unit Plate	1
52	9KA 81G9 66	Slide Gear T		1
53	9KA 81A2 90	Feed Motor Ass'y		1
53-1	-	Feed Motor RD-050Y		(1)
53-2	-	Warm Gear T		(1)
54	-	Turn Table Ass'y		1
55	-	S Motor RF-310T114B		1
56	9KS 01W0 56	Push Switch-SPPB-11	Head Sent Limit Switch SW	1
57	9KH 0PM3	Optical Pick Up Ass'y HOP-M3		1
58	9KA 81H1 07	Slide	Slide Shaft	2
59	9KM 20N0 03	M2X3 Pan Screw		4