

# DENON

Hi-Fi Personal Component System

## SERVICE MANUAL

EUROPE & U.K. models

### PERSONAL COMPONENT SYSTEM

UNIT No. UDRA-70 (MW LW FM Stereo Receiver)

UNIT No. UDR-70 (Cassette Tape Deck)

UNIT No. UCD-70 (Compact Disc Player)

D70 Aho

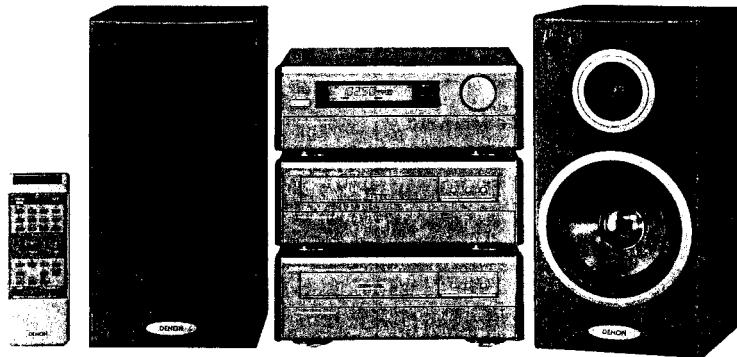

The D-70 Personal Component System consists of the following:

Receiver Section	UDRA-70
Remote Control Unit	RC-142
Cassette Deck Section	UDR-70
CD Section	UCD-70
Speaker Section	USC-70

## MAIN FEATURES

- **30 FM/AM station random preset tuner**
  - \* Random presetting makes for easy operation and will come in handy when the FM stations increases in the future.
- **Power amplifier designed for quality sound**
  - \* 30W + 30W high quality power amplifier.
- **SDB control**
  - \* Super dynamic bass control for clear low bass sound.
- **Super linear converter and high performance digital filter**
  - \* DENON's unique systems for preventing loss of CD sound quality create an excellent sound field.
- **Editing circuit included**
  - \* When performing edited recording onto tapes, tracks can be selected automatically so that the blank space on the tape is minimum.
- **Dolby B, C N.R**
  - \* For playback and recording with high quality sound.
- **CD SRS circuit**
  - \* CDs can be recorded at the touch of a button.
- **Easy-to-use remote control unit**

Check that the following parts are included in the package aside from the main unit:

- ① Operating Instructions ..... 1
- ② FM Antenna ..... 1
- ③ AM Loop Antenna ..... 1
- ④ Remote Control Unit ..... 1
- ⑤ R6P/AA batteries ..... 2
- ⑥ System Connector ..... 2
- ⑦ FM Antenna adapter ..... 1

# NIPPON COLUMBIA CO., LTD.

CD SECTION

PART NAMES AND FUNCTIONS

CD PLAYER

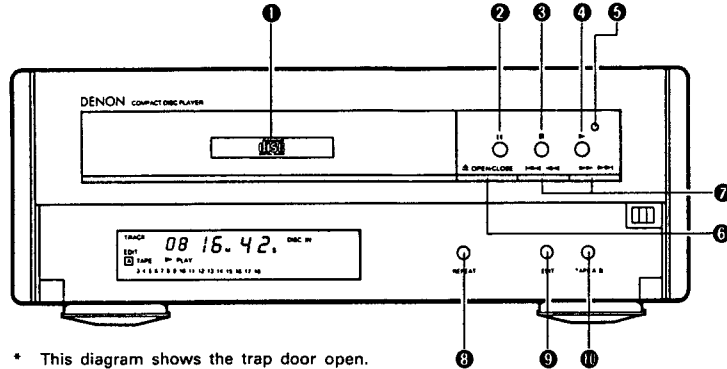

\* This diagram shows the trap door open.

- 1 Disc tray**  
The disc tray opens forward when the OPEN/CLOSE button 6 is pressed.  
To close the disc tray, press the OPEN/CLOSE button 6 again.
- 2 II PAUSE button**  
Press this button to stop playback temporarily.  
Press the PLAY button to resume playback.
- 3 ■ STOP button**  
Press this button to stop playback.
- 4 ► PLAY button**  
Press this button to start playing the disc.  
If pressed when the disc holder is open, the disc holder closes and playback begins.
- 5 Play indicator**  
This lights when the disc is played and sound is output.
- 6 OPEN/CLOSE button**  
Press this button to open and close the disc holder.  
Press once to open the disc holder forward, then press again to close the disc holder.

- 7 ◀◀◀ (automatic/manual search reverse button)**  
Press this button to move the pickup back to the beginning of the desired track.  
Press in the play or pause mode to move back a number of tracks equal to the number of times the button is pressed.
- ▶▶▶ (automatic/manual search forward button)**  
Press this button to move the pickup forward to the beginning of the desired track.  
Press in the play or pause mode to move forward a number of tracks equal to the number of times the button is pressed.  
\* The automatic search function is set if the button is released within 0.5 seconds, and the manual search function is set if the button is held in for more than 0.5 seconds.
- 8 REPEAT button**  
Press this button for repeat playback.
- 9 EDIT button**  
Press this button for edited recording (dividing the tracks to be recorded to fit onto sides A and B of a tape according to the tape's length).
- 10 TAPE A/B button**  
Press this button during editing to switch the display between the display for side A and the display for side B of the tape.

CD PLAYER DISPLAY

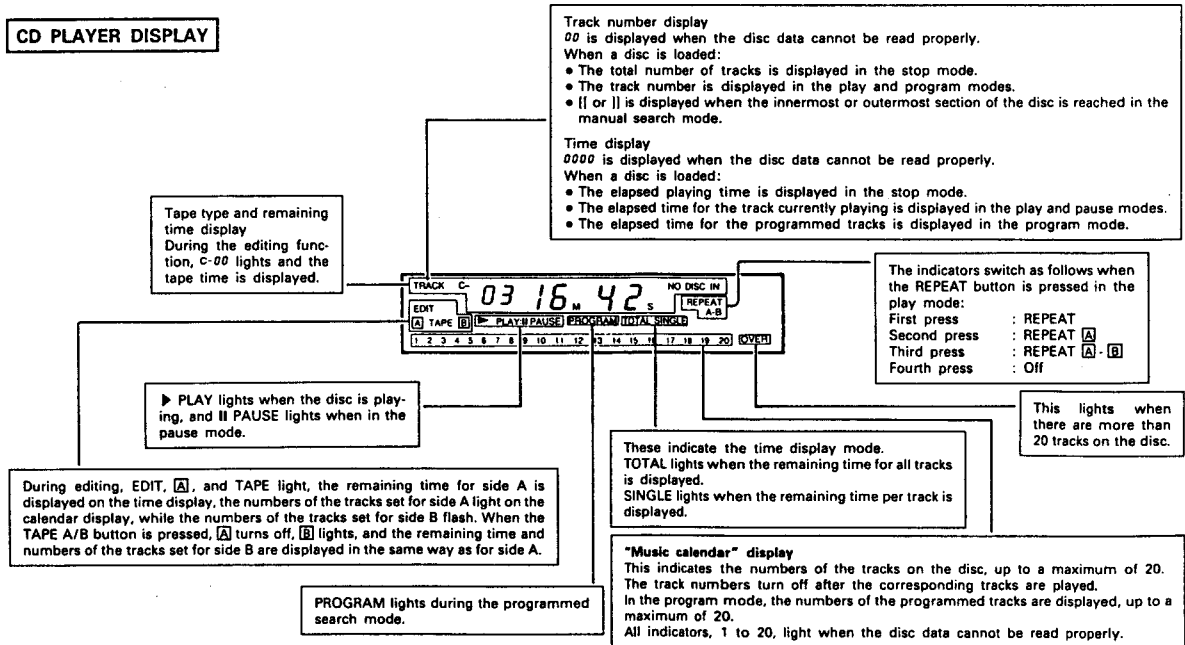

• NO DISC lights on the display if no disc is loaded, or if the disc is loaded upside-down or is heavily scratched or dirty.

## REMOVAL OF EACH SECTION

(Follow this procedure in the reverse order when assembling.)

## 1. Removal of the top cover

- ① Remove the 5 screws which fasten the top cover.
- ② Press the ▲ OPEN/CLOSE button and eject the CD tray.
- ③ Remove the loader panel (D) assembly in the direction of the arrow.
- ④ Press the ▲ OPEN/CLOSE button and retract the CD tray.
- ⑤ Remove the 2 screws which fasten the front panel assembly. At this time, remove with care the connector which connects the main unit assembly and the front panel side assembly.

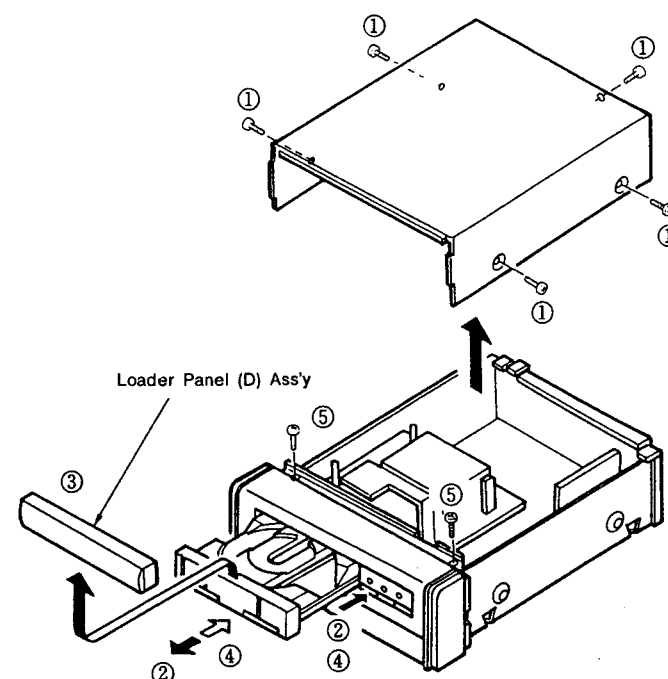

- ⑥ Stand the main unit as illustrated in the diagram and remove the 2 screws which fasten the inner panel assembly.
- ⑦ Slightly loosen the screws of the 2 front legs.
- ⑧ Remove the hooks of the chassis from the inner panel assembly.
- ⑨ Remove the front panel assembly in the direction of the arrow.

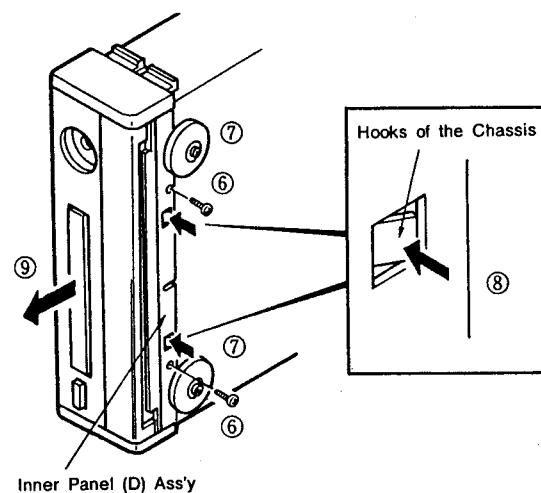
2. Removal of the printed wiring board assembly  
LCD UNIT (1U-2280-2)

- ⑩ Remove the 2 screws which fasten the LCD unit.
- ⑪ Remove the 4 screws which fasten the various boards.
- ⑫ Remove the hooks of the inner panel assembly.

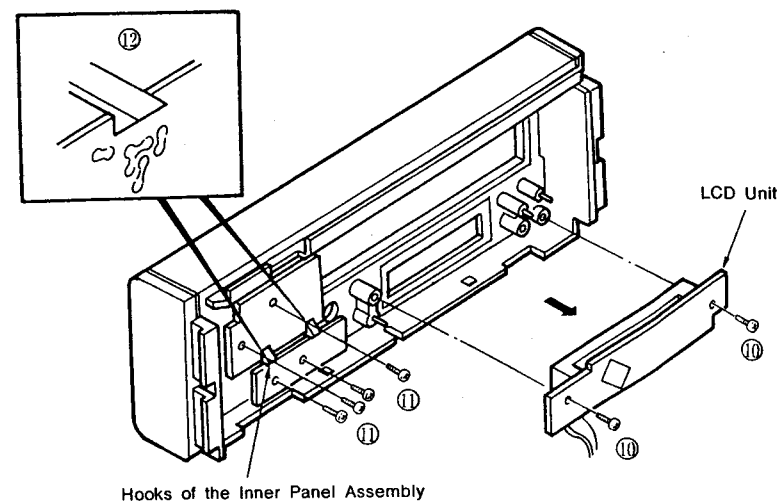

## 3. Removal of the CD mechanism unit

- ⑬ Remove the 3 screws which fasten the CD mechanism unit. At this time, remove with care the connector which connects the CD mechanism unit and the main unit assembly.

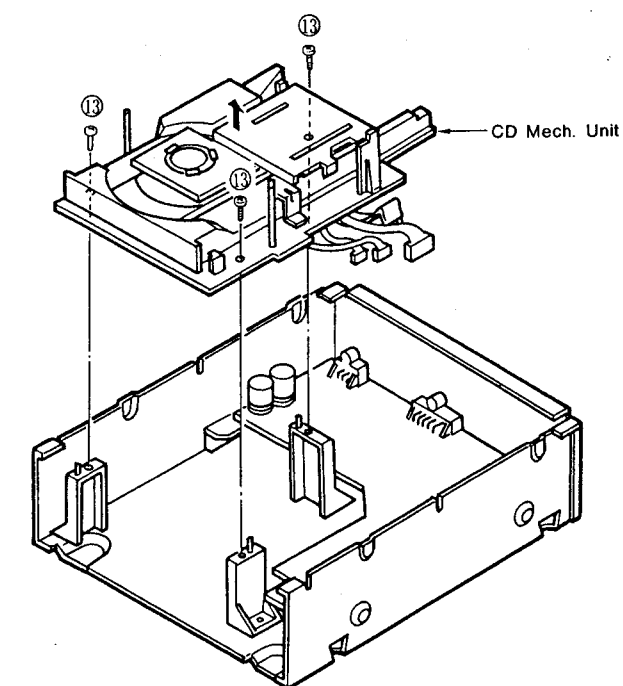

## MAIN UNIT ASSEMBLY (1U-2280-1)

- ⑭ Remove the 6 screws which fasten the main unit assembly.
- ⑮ Use radio pliers or another suitable tool to remove the 2 PCB holders which fasten the main unit assembly.

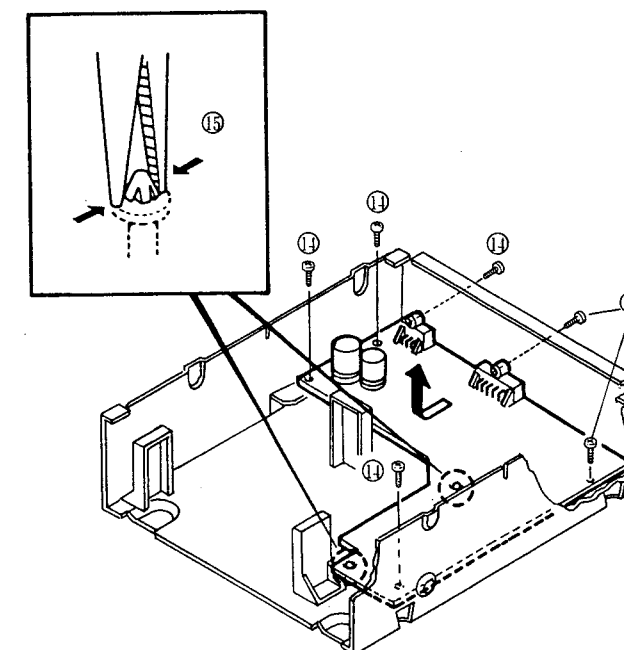

## ※ Removing connectors (Type 1)

- Hold the top part of the connector, release the lock, and pull out the wires.
- When the lock of the top has not come off, the wires will not come out, so check that the lock has come off.

## ※ Connecting the connectors (Type 1)

- Press the top of the connector and lock it to the base, fix the bend of the wires, match the polarities, and press in. When the top section is not locked, the wires will come out, so check that the top section is locked.

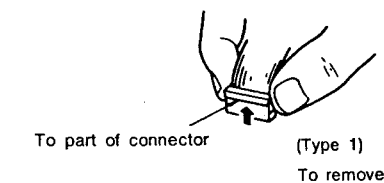

CD SECTION

BLOCK DIAGRAM

1 2 3 4 5 6 7 8

A  
B  
C  
D  
E

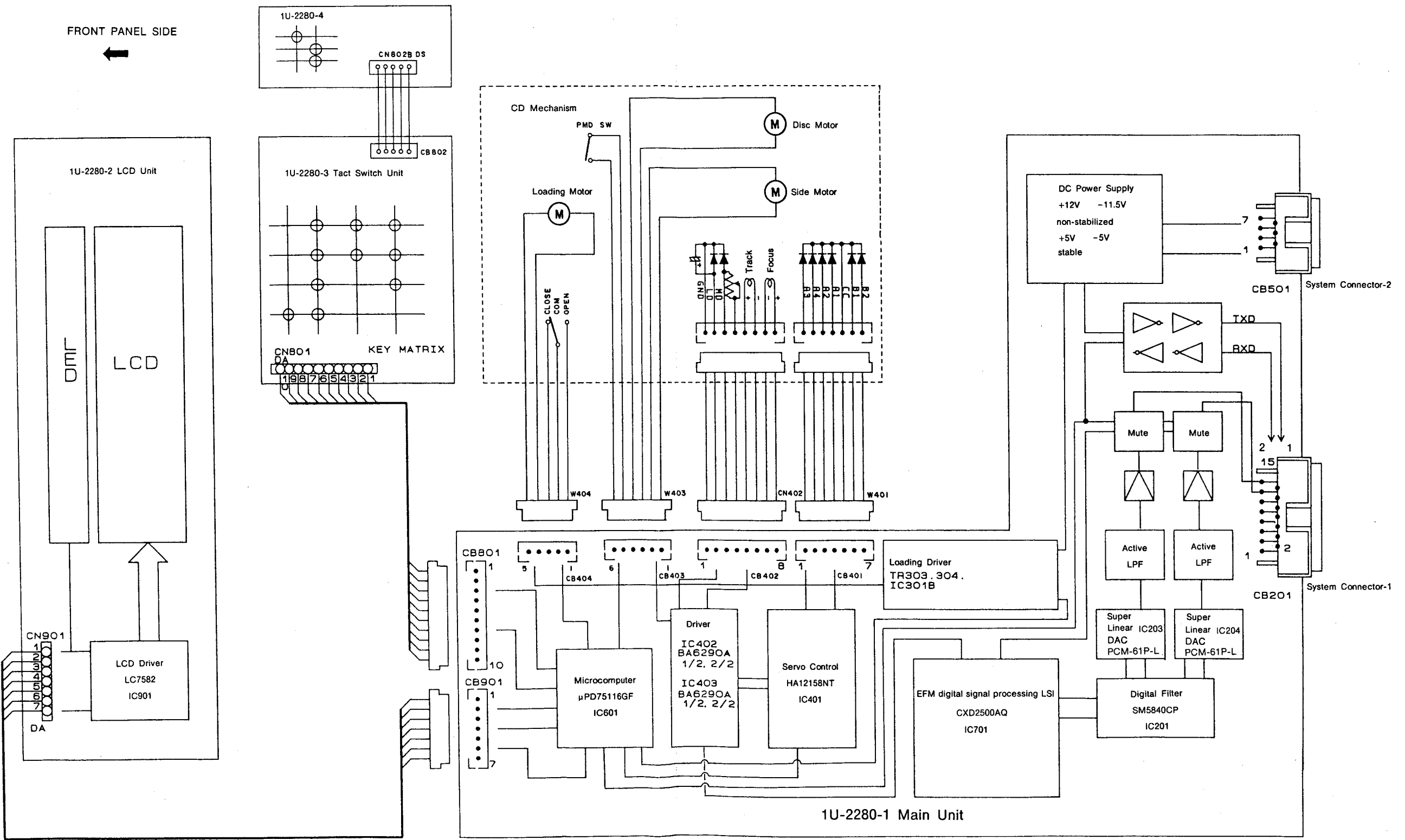

LASER PICKUP

Connections Diagram

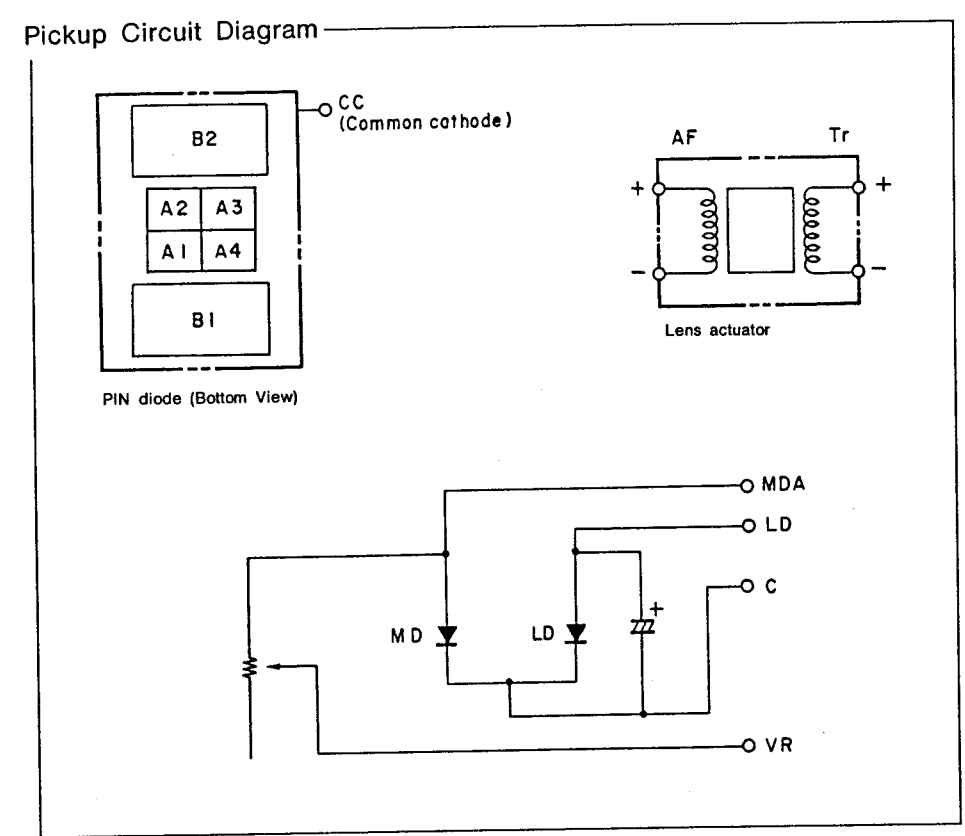

Basic Laser Drive Circuit Diagram

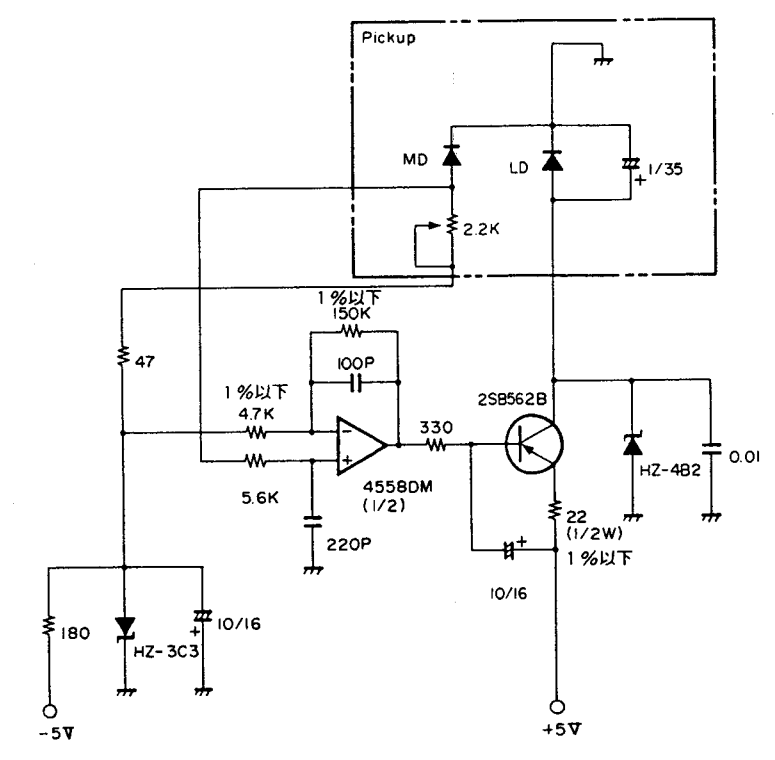

Measuring Circuit Diagram

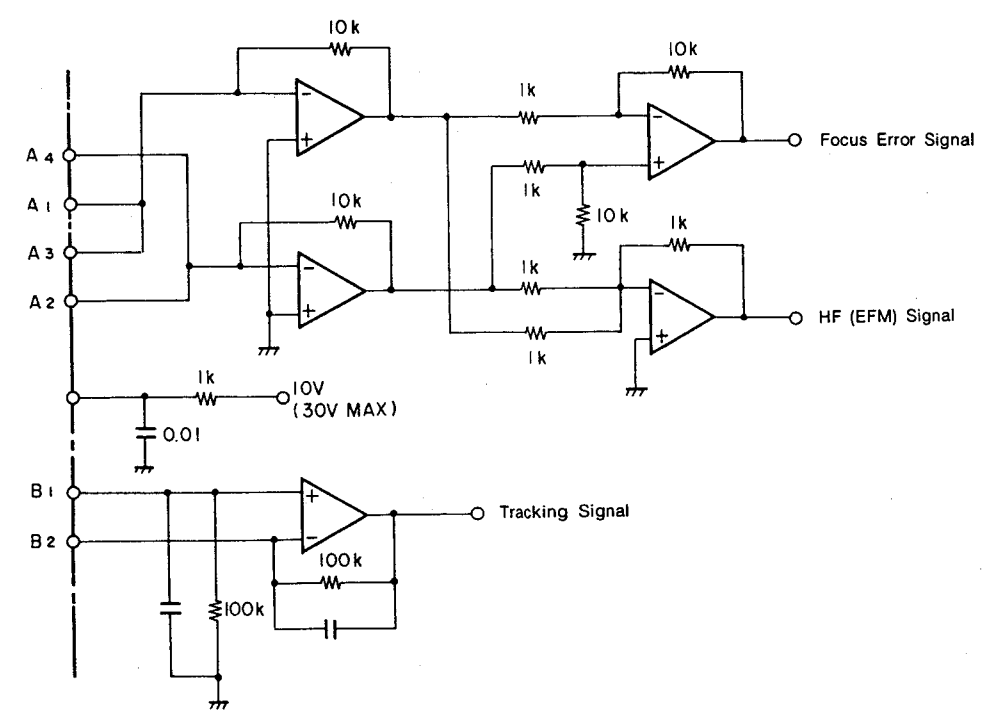

1. PD connector

PH pin post 7 pins (Type number B7B-PH-K-S manufactured by Nippon Atchaku Tanshi Hanbai K.K.)

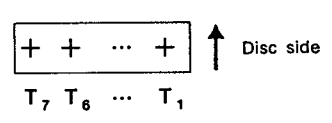

Tn	1	2	3	4	5	6	7
Item	A <sub>3</sub>	A <sub>4</sub>	A <sub>2</sub>	A <sub>1</sub>	CC	B <sub>1</sub>	B <sub>2</sub>

2. LD actuator connector

PH pin post 8 pins (Type number B8B-PH-K-S manufactured by Nippon Atchaku Tanshi Hanbai K.K.)

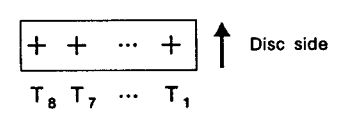

Tn	1	2	3	4	5	6	7	8
Item	C	LD	MDA	VR	TR+	TR-	AF-	AF+

**CD SECTION**

**● Precautions in Use**

Read the following carefully before handling.

**1. Laser control circuit**

The light output of the laser diode (LD) is greatly affected by temperature, so a built-in monitor photodiode should be used in the LD to supplement the light output.

In order to get rid of the dispersion of the monitor photodiode, the semiconductor resistor accompanying the pickup has been adjusted so that the mirror surface level of the HF signal becomes 250 mV when the measurement circuit of this manual and the basic laser drive circuit are used. When designing a new laser drive circuit, note that the life of the laser will be shortened when the mirror level of the HF signal becomes 275 mV with this measuring circuit.

**2. Wiring**

Be sure to use the specified connectors for the wiring.

Note that the eye pattern may deteriorate when there is a microprocessor or other digital noise source in the vicinity from the photodiode to the harness.

Note that a poor connection related to the LD and actuator connector will cause deterioration of the laser, and so there should not be any looseness of connectors.

**● Precautions in Handling**

This mechanism has been precisely assembled and adjusted at a special factory. It should not be disassembled or adjusted without good reason. Pay attention to the following points related to handling.

**1. General items**

**(1) Storage**

Avoid storage in places with high temperatures and high humidity, and in places exposed to a lot of dust.

**(2) Handling**

The unit has been precisely adjusted and care should be taken so as not to expose the unit to shocks through dropping or careless handling.

**2. Semiconductor laser (LD)**

**(1) Protection of the eyes from the laser**

The output of the LD is via an objective lens and is a maximum of 400 μW, but reaches approximately  $1.3 \times 10^4 \text{ W/cm}^2$  in places where there is condensed light. After being condensed by the objective lens, the beam widens and so is all right at a distance of 30 cm or further, but during operation the LD should never be allowed to be viewed directly or through another lens or mirror since this is dangerous.

**(2) Destruction by surge currents or static electricity**

When a large current flows through the LD, even for a very short period, the strong light which the LD generates itself will advance the deterioration of the LD or destroy it.

Wire a switch into the LD drive circuit or provide another method of preventing the flow of surge currents. Also, when handled without care, the LD can be destroyed instantly by the application of static electricity from the body. Therefore, when handling the LD, be sure to ground your body and ground the measuring instruments, jigs, and tools. It is also desirable to use a grounding mat on the work bench and floor.

**3. Lens actuator**

(1) The actuator section uses a strong magnetic circuit, so that when magnetic bodies come too close, their characteristics are altered.

Also be careful not to allow foreign matter to enter from the cover gap.

**(2) Lens cleaning**

Dust or dirt adhering to the objective lens will change the performance.

To clean, blow the dirt away with clean air from an air blower.

**4. Handling**

Be sure not to contact the lens when handling the LD.

Note that direct contact of the body or other objects with the circuit of the LD board will cause deterioration to occur, so sufficient care should be taken.

**SERVICE POINTS**

**1. Parts replacement of the tray mechanism (Figs. 1 and 2)**

**(1) Removal of the tray**

Open the tray and use a flat-bladed screwdriver to press the stopper portions of Fig. 1 (one each in the left and right locations) in the direction of the black arrow, then remove in the direction of the white arrow.

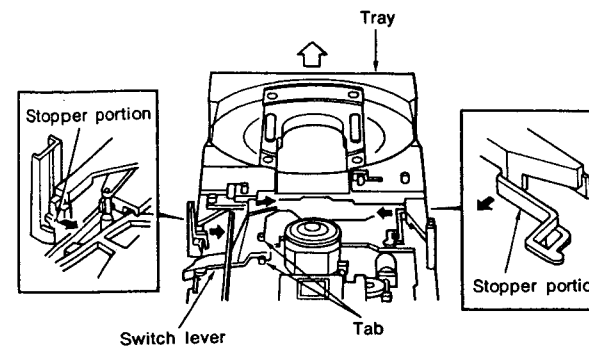

Fig. 1

**(2) Mounting of the tray (Figs. 1, 2, and 3)**

Rotate the switch lever in the direction of the arrow, set the latches of the tray as illustrated in Fig. 2, then align the rails of the tray in the grooves of the loading plate, and insert so that the pinch lever pins of the switch lever enter into the rack grooves. Push in the tray while pressing the stopper portion inside a little.

(Check that the latches are in the positions illustrated in Fig. 2.)

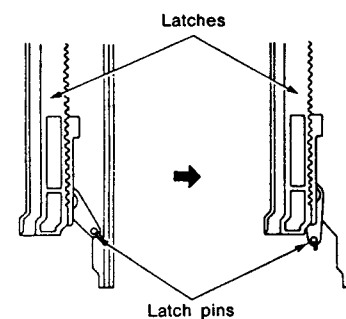

Fig. 2

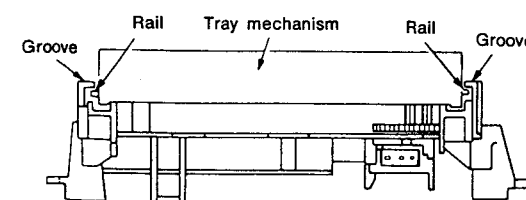

Fig. 3

**(3) Replacement of the disc holder (Fig. 4)**

With the tray removed, remove tabs (D) and (E) of the disc receptacle of Fig. 4, then lift up and off.

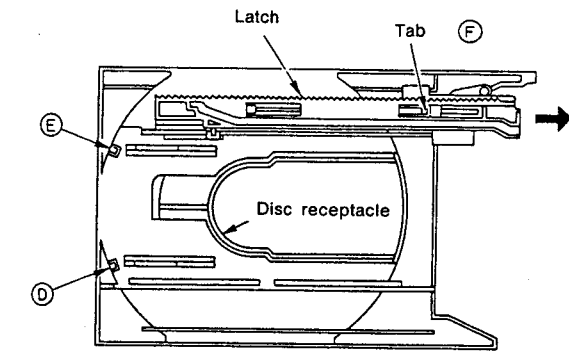

Fig. 4

**(4) Replacement of the latches (Fig. 4)**

Set the latches into the condition of Fig. 4, lift the latch tab (F) up about 1 mm with a flat-bladed screwdriver and remove the rack in the direction of the arrow.

**(5) Removal of the loading motor and switches (Fig. 5)**

Remove the belt from the loading motor, then remove the 3 tabs. Remove the fixed tabs from the various switches.

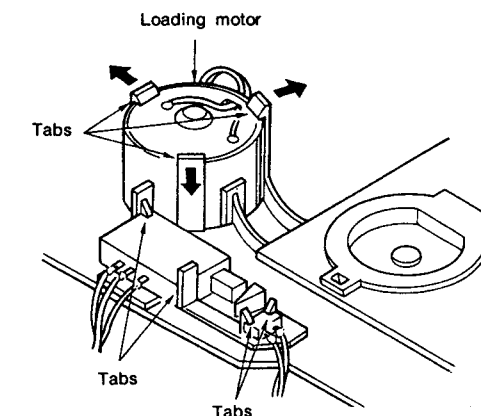

Fig. 5

**(6) Replacement of the belt**

Replace the belt with the tray removed.

**(7) Replacement of the clasper (Fig. 6)**

Hook the elongated holes of the clasper onto the C arm, bend the elongated hole sections and attach.

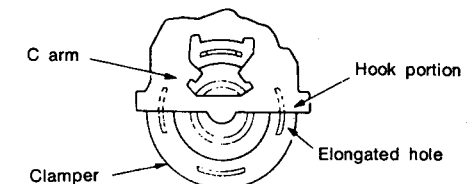

Fig. 6

**(8) Replacement of the switch lever (Fig. 1)**

Remove the tabs of the bottom side (in 2 locations).

2. Removal of the unit mechanism (Fig. 7)

After removing the loading mechanism, remove the tab of the bottom surface (in one location) as illustrated in Fig. 7.

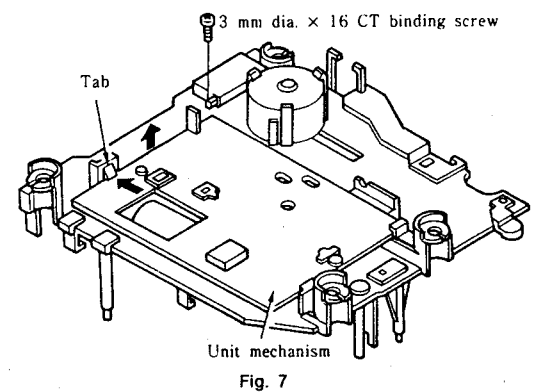

- (1) To replace the DC motor (D2) and the turntable, follow the procedure below
- 1) Pull the turntable (plastic) off vertically from the unit plate.
  - 2) When fitting on the servicing turntable (metal), make a height adjustment. (Fig. 8)
- Do not exert excessive force to the shaft of the DC motor (D2) at this time.

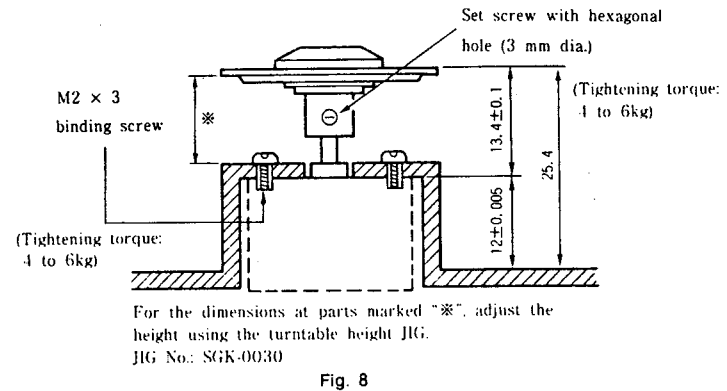

- 3) At the time of service replacement of the DC motor (D2), do not apply excessive force in direction B. When part C of the unit plate is misshapen, it will cause eye pattern deterioration. (Fig. 9)

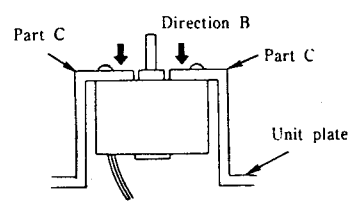

Fig. 9

**NOTE:**

- Motor replacement or turntable replacement method  
Remove the pressure-fitted turntable, and remove the motor screws.
- Do not reuse a turntable (plastic) that has been removed once.

- (2) When disassembling and assembling the unit mechanism, assemble with wiring resembling that of Fig. 10

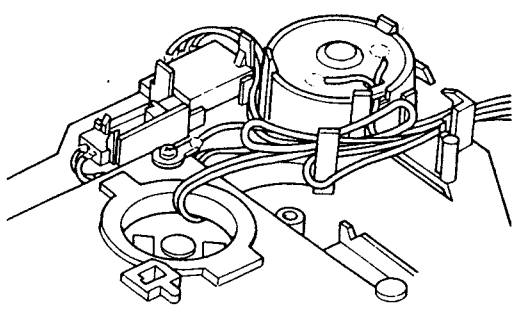

Fig. 10

3. Inspection of the objective lens (Fig. 11)

Handle so as not to get dirt or dust on the objective lens of the lens actuator section. Note that when used for a long period, dirt or dust may have adhered to the objective lens. Try cleaning the surface of the objective lens with a dry, clean cotton swab. If the dirt still does not come off, moisten the cotton swab with a small amount of water and wipe. When doing this, be careful not to get water on any parts other than the lens.

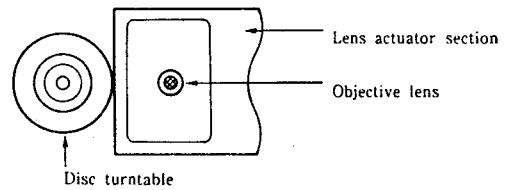

Fig. 11

4. Inspection for laser breakdown

The laser is normally driven with a current of 30 to 80 mA. If this laser drive current value is measured at 120 mA or higher in the circuit, the laser may be thought to be faulty. (The current value is measured by taking the voltage (0.99 to 3.3 V) across both ends of R401, which is 33 ohms).

5. Precautions at time of servicing (Fig. 12)

- (1) Semiconductor laser
- The semiconductor laser is very susceptible to static electricity, destruction and surge currents. Be careful never to touch the terminals of the semiconductor laser and the terminals of the flexible board with your hands or a tool.
- As illustrated in Fig. 12, the current and light intensity characteristics increase abruptly once the threshold current value is exceeded.
- Also note that this threshold current differs a little from laser to laser. In view of this, when replacing the unit mechanism or any work that involves setting the amount of light of the laser, be sure to turn the adjustment control VR401 fully in the counterclockwise direction, and then raise it to the specified value.

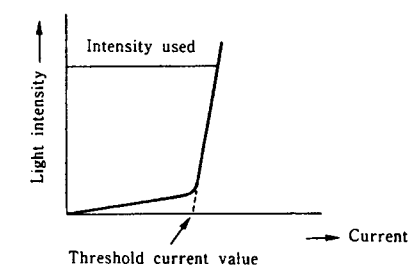

Fig. 12

- (2) Handling the unit mechanism (Fig. 13)
- When handling the pickup mechanism and the unit mechanism, use a ground ring such as the one illustrated in Fig. 13. (A ground ring can be constructed using ordinary lead wire.)

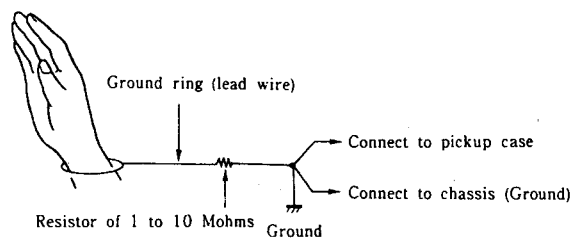

Fig. 13

6. Inspection of the actuator (Fig. 14)

Check the resistance value of the actuator coil. It is normal if the values are as follows:

- Focusing coil ..... 30 ohms
- Tracking coil ..... 10 ohms

If the coils are open or shorted, the actuator may be thought to be broken. Also, a 1.5 V battery can be used to observe if the lens moves.

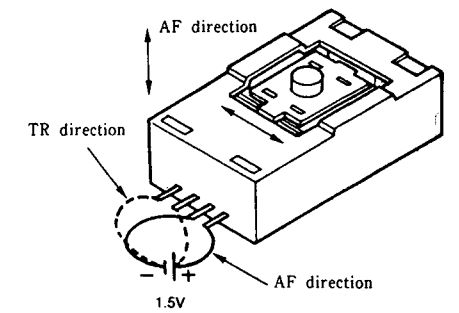

Fig. 14

CD SECTION

ADJUSTMENT METHOD

The microprocessor contained in this unit incorporates a service program which allows a wide variety of service adjustments to be conducted easily by using the operation buttons.

1. Method of starting the service program

NOTE: When the service program starts, normal operations are not longer possible with the operation buttons.

2. Operation functions when the service program is operating

Operation button	Operation function	Description
▲ OPEN/CLOSE	Opens and closes the disc holder.	<ul style="list-style-type: none"> <li>● Opening and closing takes place when the rotation of the disc has stopped.</li> <li>● Other operation buttons are performed when the opening and closing operation is completed.</li> </ul>
■ STOP	Stops system operation.	<ul style="list-style-type: none"> <li>● Track number display becomes <i>D 1</i>.</li> <li>● Press when an adjustment has been completed or is redone.</li> </ul>
▶ PLAY	Operates the focus servo and rotates the disc.	<ul style="list-style-type: none"> <li>● Press at the time of the tracking offset adjustment.</li> <li>● After the operation is completed, the track number display becomes <i>D 2</i>.</li> </ul>
PAUSE	Operates the focus servo, tracking servo, slide servo, and the spindle servo.	<ul style="list-style-type: none"> <li>● When the play button has been pressed, the tracking servo and slide servo are operated.</li> <li>● After the operation is completed the track number display becomes <i>D 3</i>.</li> </ul>
Other buttons	Operation is not normal.	<ul style="list-style-type: none"> <li>● Do not operate buttons other than the above.</li> <li>● When a button is operated by mistake, immediately turn the power switch off.</li> </ul>

NOTE: Do not use the remote control while the service program is operating.

3. Adjustment method

(1) Measuring instruments required in the adjustment

- ① DC voltmeter
- ② Oscilloscope

Outline Diagram of Adjustment Locations

1U-2280A-1 CD Unit (Component Side)

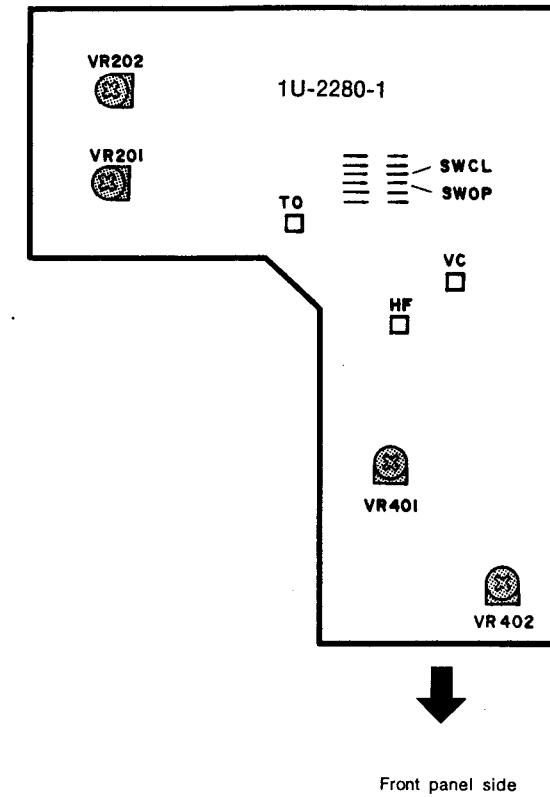

NOTE: VR201 and 202 are adjusted at the factory before shipping and there is no need to adjust.

(2) Adjustment preparation

1.	Set the adjustment control (VR401, 402) to the position illustrated.	<p>VR401 (T-OFFSET)</p> <p>VR402 (F-OFFSET)</p>
2.	Adjustment step	<ul style="list-style-type: none"> <li>1. Tracking offset</li> <li>2. Focus offset</li> </ul>



(3) Tracking offset adjustment

Wiring Diagram	
Adjustment location	Adjustment Procedure
(Control)	
VR401	1. Adjust the VR401 "T-OFFSET" control and set the $0mV \pm 5mV$ .

(4) Focus offset Adjustment

Wiring diagram			
Oscilloscope		Adjustment location	Check items
V	H	Control	Oscilloscope
50mV/div or 20mV/div	0.2 $\mu$ /div or 0.5 $\mu$ /div	VR402	<p>Adjust for Fine waveform</p>
Adjustment Procedure			
<p>1. Press the <b>▶ PLAY</b> button.</p> <p>2. Adjust VR402 ("F-OFFSET") so that the eye pattern jitter is minimum.</p>			

CD SECTION

PRINTED WIRING BOARD

1

2

3

4

5

6

7

8

Component Side

1U-2280A CD UNIT ASS'Y

A

B

C

D

E

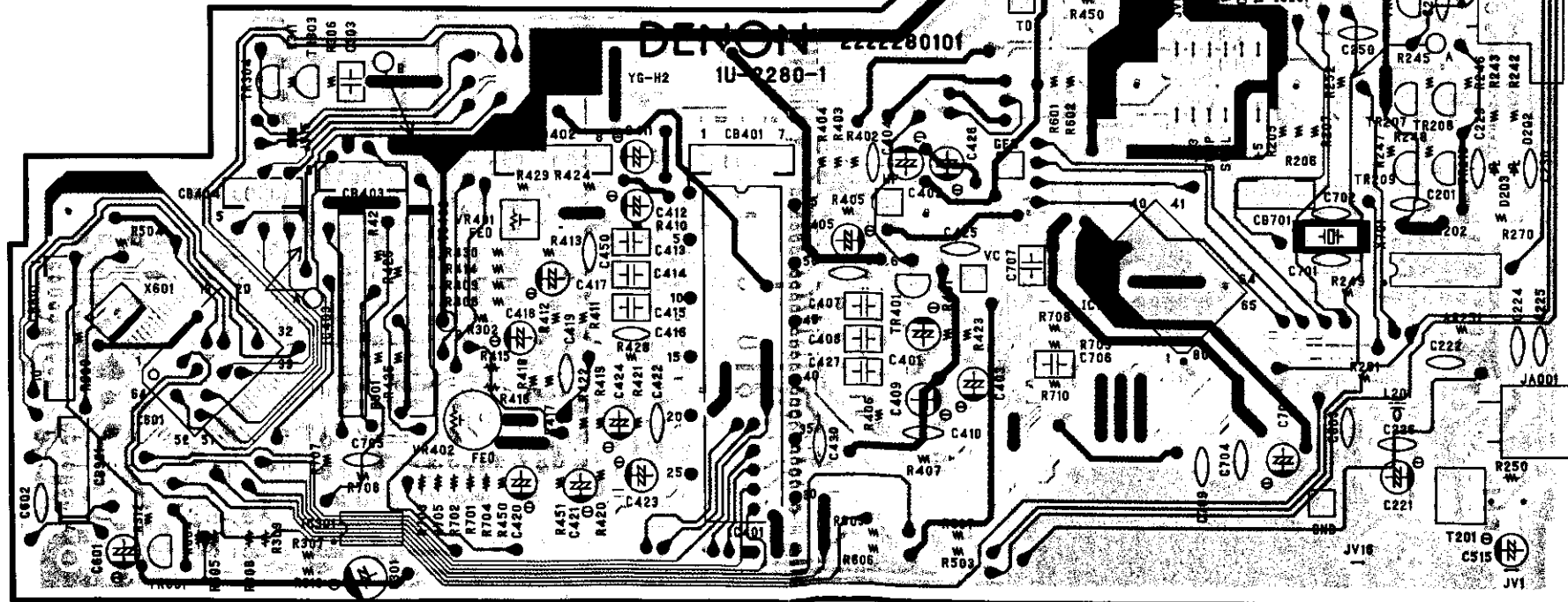
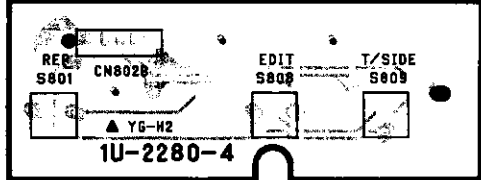
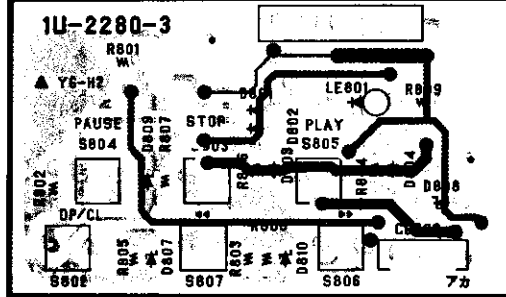
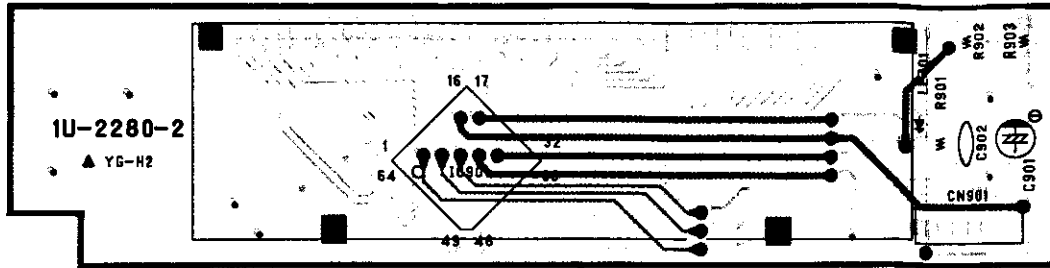

CD SECTION

1 2 3 4 5 6 7 8

Pattern Side

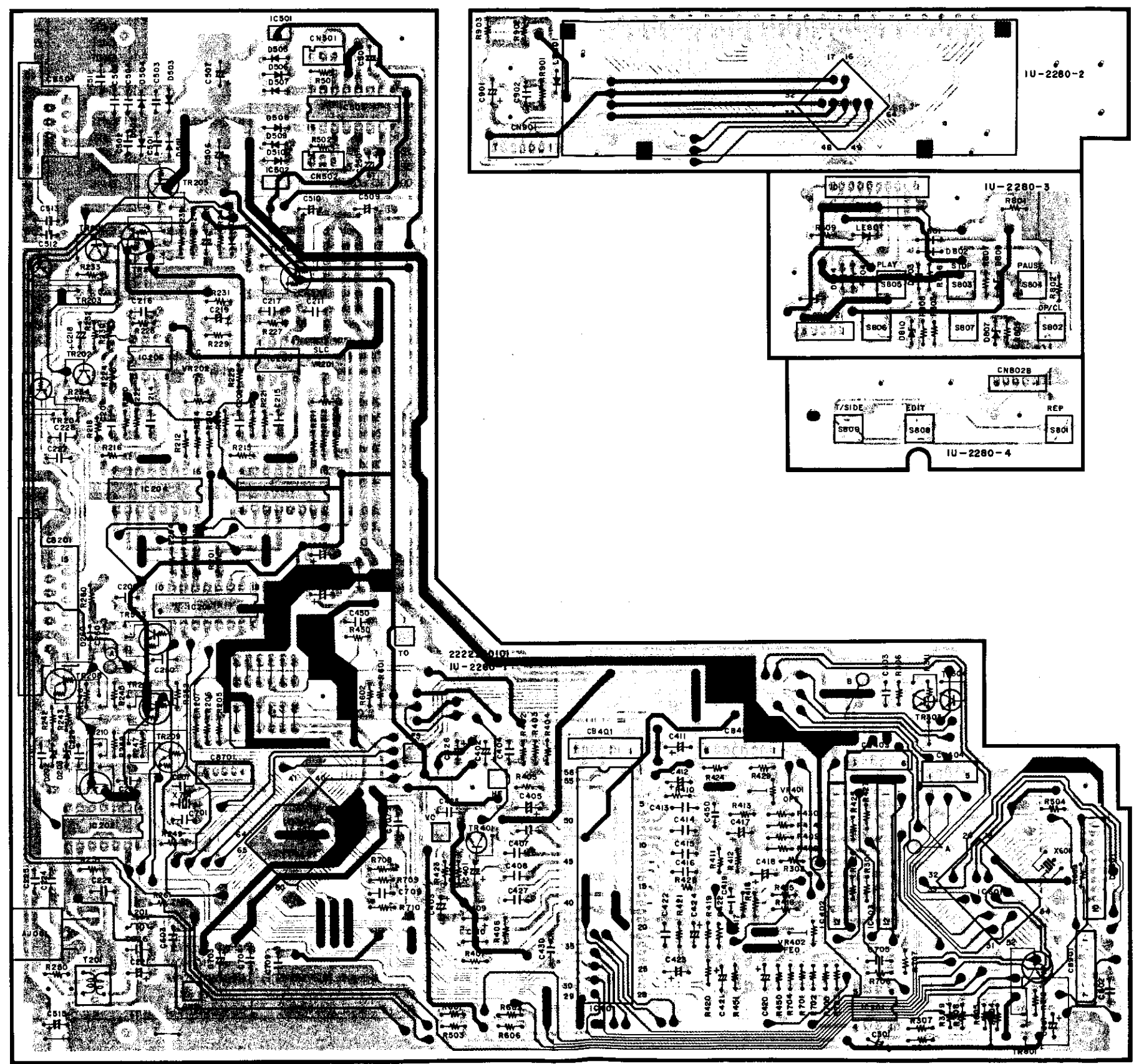

A

B

C

D

E

CD SECTION

NOTES ON THE PARTS TABLE

NOTE FOR PARTS LIST

- Part indicated with the mark "⊙" are not always in stock and possibly to take a long period of time for supplying, or in some case supplying of part may be refused.
- When ordering of part, clearly indicate "1" and "I" (i) to avoid mis-supplying.
- Ordering part without stating its part number can not be supplied.
- Part indicated with the mark "★" is not illustrated in the exploded view.
- Not including Carbon Film ±5%, 1/6 W, 1/4W Type in the P. W. Board parts list.
- Parts marked with this symbol  $\Delta$  have critical characteristics. Use ONLY replacement parts recommended by the manufacturer.
- Refer to the following table for the codes of the resistors and capacitors appearing on the parts list.

Resistors

Ex.: **RN 14K 2E 182 G FR**

Type	Shape and performance	Power	Resistance	Allowable error	Others
RD : Carbon RC : Fixed RS : Metallic film RW : Winding RN : Metal film RK : Metal mixture	2B : 1/4W 2E : 1/2W 2H : 1W 3A : 1W 3D : 2W 3F : 3W 3H : 5W	F : ±1% G : ±2% J : ±5% K : ±10% M : ±20%	P : Pulse-resistant type NL : Low noise type NB : Non-burning type FR : Fuse resistor F : Lead wire forming		

★ Resistance  
1 8 2 ⇒ 1800 ohm = 1.8 kohm  
Indicates number of zeros after effective number  
2-digit effective number, decimal point indicated by R.  
• Units: ohm

Capacitors

Ex.: **CE 04W 1H 2R2 M BP**

Type	Shape and performance	Dielectric strength	Capacity	Allowable error	Others
CE : Aluminum foil electrolyte CA : Aluminum solid electrolyte CS : Tantalum electrolyte CQ : Film CK : Ceramic CC : Ceramic CP : Oil CM : Mica CF : Metallized CH : Metallized	0J : 6.3V 1A : 10V 1C : 16V 1E : 25V 1V : 35V 1H : 50V 2A : 100V 2B : 125V 2C : 160V 2D : 200V 2E : 250V 2H : 500V 2J : 630V	F : ±1% G : ±2% J : ±5% K : ±10% M : ±20% Z : +80% -20% P : +100% -0% C : ±0.25pF D : ±0.5pF - : Others	HS : High stability type BP : Non-polar type HR : Ripple-resistant type DL : For charge and discharge HF : For assuring high frequency U : UL part C : CSA part W : UL-CSA type F : Lead wire forming		

★ Capacity  
2 R 2 ⇒ 2.2 μF  
1-digit effective number, decimal point indicated by R.  
2-digit effective number, decimal point indicated by R.  
• Units: μF, (for P, pF (μμF))  
• When the dielectric strength is indicated in AC, "AC" is included after the dielectric strength value.

1U-2280A CD UNIT PARTS LIST

Ref. No.	Part No.	Part Name	Remarks	Ref. No.	Part No.	Part Name	Remarks
<b>SEMICONDUCTORS GROUP</b>							
IC201	262 1450 008	IC SM5840CP		C410	253 9030 060	BC Ceramic 0.01 μF/25V	CK45-1E103K
IC203,204	262 1409 004	IC PCM61P-L		C405	254 4252 006	Electrolytic 10 μF/16V	CE04W1C100M
IC205,206	263 0712 009	IC :RC4558P		C406	253 9031 069	BC Ceramic 2700pF/25V	CK45-1E272K
IC301	263 0712 009	IC :RC4558P		C407	256 1034 018	Metalized 0.033 μF/50V	CF93A1H333J
IC401	263 0749 001	IC HA12158NT		C408	255 1120 042	Film 0.0022 μF/50V	CQ93M1H222J
IC402,403	263 0750 003	IC BA6290A		C409	254 4260 032	Electrolytic 0.47 μF/50V	CE04W1HR47M
IC501,502	268 0073 905	IC ICP-N15	IC Protector	C411	254 4254 006	Electrolytic 10 μF/16V	CE04W1C100M
IC503	263 0693 005	IC M5290P		C412	254 4260 032	Electrolytic 0.47 μF/50V	CE04W1HR47M
IC601	262 1456 206	IC μPD75116GF-E16-3BE	μ-Com	C413	256 1034 047	Metalized 0.056 μF/50V	CF93A1H563J
IC701	262 1514 009	IC CXD2500AQ		C414	256 1034 005	Metalized 0.027 μF/50V	CF93A1H273J
IC901	263 0533 000	IC LC7582		C415	256 1034 005	Metalized 0.15 μF/50V	CF93A1H154J
TR203,204	269 0073 908	Transistor DTC314TS	built in Resistor	C416	253 1179 071	Ceramic 390pF/50V	CK45B1H391K (DD-3)
TR205	269 0046 906	Transistor DTA114ES	built in Resistor	C417	254 4252 019	Electrolytic 22 μF/16V	CE04W1C220M
TR206~209	269 0020 906	Transistor DTC114ES	built in Resistor	C418	254 4260 016	Electrolytic 0.22 μF/50V	CE04W1HR22M
TR210	269 0040 902	Transistor DTC144ES	built in Resistor	C419	253 1004 007	Ceramic 1000pF/50V	CK45B1H102K
TR303	274 0144 907	Transistor :BC368		C420	254 4250 026	Electrolytic 100 μF/6.3V	CE04W0J101M
TR304	272 0101 902	Transistor :BC369		C421	254 4254 006	Electrolytic 10 μF/16V	CE04W1C100M
TR401	271 0102 924	Transistor 2SA1015 (GR)		C422	253 1063 006	Ceramic 5600pF/50V	CK45B1H562K
TR501	274 0136 009	Transistor 2SD1913		C423	254 4260 049	Electrolytic 1 μF/50V	CE04W1H010M
TR502	272 0093 007	Transistor 2SB1274		C424	254 4260 016	Electrolytic 0.22 μF/50V	CE04W1HR22M
TR503,504	269 0020 906	Transistor DTC114ES	built in Resistor	C425	253 9030 060	BC Ceramic 0.01 μF/25V	CK45-1E103K
TR801	269 0046 906	Transistor DTA114ES	built in Resistor	C426	254 4252 024	Electrolytic 47 μF/10V	CE04W1A470J
D201	276 0432 903	Diode 1SS270A		C427	255 1121 026	Film 0.015 μF/50V	CQ93M1H153J
D202,203	276 0462 915	Zener Diode HZS6B-2	6V	C430	253 1004 007	Ceramic 1000pF/50V	CK45B1H102K
D260	276 0462 915	Zener Diode HZS6B-2	6V	C450	253 1004 007	Ceramic 1000pF/50V	CK45B1H102K
D501~510	276 0550 908	Diode 1SR139-200		C506,507	254 4255 704	Electrolytic 3300 μF/16V	CE04W1C332MC
D801~804	276 0432 903	Diode 1SS270A		C508	254 4260 003	Electrolytic 0.1 μF/50V	CE04W1H0R1M
D807~810	276 0462 915	Zener Diode HZS6B-2	6V	C509,510	254 4254 051	Electrolytic 220 μF/16V	CE04W1C221M
LE801	393 9483 902	LED (SLR-34MC70F120)	Green	C513	253 9036 006	BC Ceramic 0.1 μF/25V	CK45-1E104Z
LE901	393 9493 002	LED Ass'y		C520	254 4260 045	Electrolytic 1 μF/50V	CE04W1H010M
LC901	393 4105 007	LCD Ass'y		C601	254 4250 026	Electrolytic 100 μF/6.3V	CE04W0J101M
<b>RESISTORS GROUP (Not included Carbon Film ±5%, 1/4W Type. Refer to the Schematic Diagram for those Parts.)</b>							
R302	245 2369 902	Metal Film 8.2kohm 1% 1/4W	RN14K2E822F	C602	253 1024 003	Ceramic 0.01 μF/50V	CK45F1H103Z
R408	245 2370 946	Metal Film 33kohm 1% 1/4W	RN14K2E333F	C602,603	253 9036 006	BC Ceramic 0.1 μF/25V	CK45-1E104Z
R409	245 2370 904	Metal Film 22kohm 1% 1/4W	RN14K2E223F	C701	253 3596 005	Ceramic 3pF/50V	CC45SL1H030C
R707	245 2370 946	Metal Film 33kohm 1% 1/4W	RN14K2E333F	C702	253 4342 041	Ceramic 5pF/50V	CC45SL1H050C
VR201,202	211 6087 928	Semi Fixed Resistor 100k ohm	V06PB104	C703	254 4250 039	Electrolytic 220 μF/6.3V	CE04W0J221J
VR401	211 6079 910	Semi Fixed Resistor 4.7k ohm	V06PB472	C704	253 9031 027	BC Ceramic 0.1 μF/25V	CK45-1E104K
VR402	211 6064 022	Semi Fixed Resistor 100k ohm	V06PB104	C705	253 9030 060	BC Ceramic 0.01 μF/25V	CK45-1E103K
<b>CAPACITORS GROUP</b>							
C200	253 9031 027	BC Ceramic 0.1 μF/25V	CK45-1E104K	C706	256 1034 034	Metalized 0.047 μF/50V	CF93A1H473J
C201	253 9036 006	BC Ceramic 0.1 μF/25V	CK45-1E104Z	C707	255 1120 026	Film 0.0015 μF/50V	CQ93M1H152J
C202,203	254 4252 037	Electrolytic 100 μF/10V	CE04W1A101M	C709	253 9031 027	BC Ceramic 0.1 μF/25V	CK45-1E104K
C208,209	255 1120 000	Film 0.001 μF/50V	CQ93M1H102J	C901	254 4299 003	Electrolytic 100 μF/16V (SRE)	CE04W1C101M
C211	253 9031 027	BC Ceramic 0.1 μF/25V	CK45-1E104K	C902	253 4350 004	Ceramic 680pF/50V	CC45SL1H681J
C213	253 9031 027	BC Ceramic 0.1 μF/25V	CK45-1E104K				
C214,215	253 3634 006	Ceramic 200pF/50V	CC45SL1H201J				
C216,217	253 3627 000	Ceramic 100pF/50V	CC45SL1H101J				
C218,219	254 4254 048	Electrolytic 100 μF/16V	CE04W1C101M				
C220	254 4254 051	Electrolytic 220 μF/16V	CE04W1C221M				
C227,228	253 3627 000	Ceramic 100pF/50V	CC45SL1H101J				
C229,230	253 3643 000	Ceramic 470pF/50V	CC45SL1H471J				
C250	253 3638 002	Ceramic 300pF/50V	CC45SL1H301J				
C260	253 3643 000	Ceramic 470pF/50V	CC45SL1H471J				
C301	254 4260 061	Electrolytic 3.3 μF/50V	CE04W1H3R3M				
C303	256 1047 005	Metalized 0.022 μF/50V	CF93A1H223JH				
C401	254 4254 006	Electrolytic 10 μF/16V	CE04W1C100M				
C402	254 4299 003	Electrolytic 10 μF/16V (SRE)	CE04W1C100M				
C403	254 4250 026	Electrolytic 100 μF/6.3V	CE04W0J101M				
C404	253 3614 000	Ceramic 100pF/50V	CC45SL1H101J				

## CD SECTION

OTHERS PARTS GROUP				Q'ty
	—	(P.W. Board)		(1)
	212 5606 905	Tact Swtich		9
X601	399 0034 002	Ceramic Vibrator	CST4.00MG	1
X701	399 0036 013	X'tal (16.9344MHz)		1
	449 0055 302	LCD Holder		1
CB404	205 0343 058	5P Connector Base (KR-PH)		1
CN802	205 0321 054	5P Connector Base (RED)	Red	1
CB403	205 0343 061	6P Connector Base (KR-PH)		1
CB401,901	205 0343 074	7P Connector Base (KR-PH)		2
CB801	205 0375 000	10P Connector Base (KR-PH)		1
CB201	204 8284 022	15P System Socket		1
CB501	204 2429 003	7P System Socket		1
CN901	204 2312 042	7P KR-DA Connector Cord	ℓ=240	1
CN801	204 2225 016	10P KR-DA Connector Cord	ℓ=150	1
CN802	203 8172 021	5P KR-DS Connector Cord	ℓ=70	1
CB402	205 0343 087	8P Connector Cord (KR-PH)		1
CN501,502	203 4564 044	3P SCN-SON Connector Cord		2

CD SECTION

SEMICONDUCTORS

● IC's

HA12158NT (IC401)

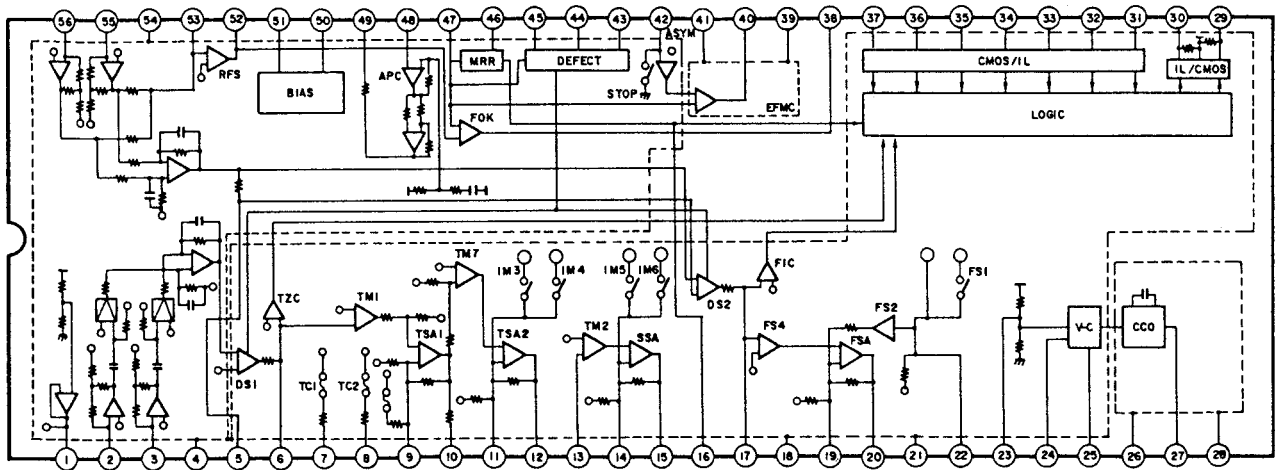
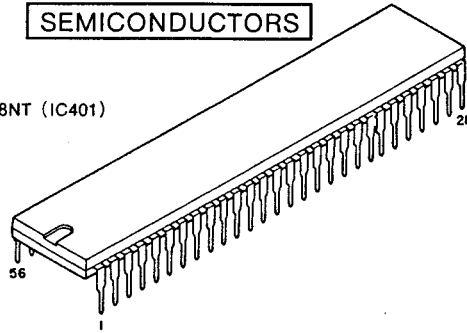

● Pin function table

Pin No.	Symbol	I/O	Function	Pin No.	Symbol	I/O	Function
1	VREF	O	Reference voltage output	29	COUT	O	Track count signal output
2	TR1	I	TR1 (I/V conversion amplifier) input	30	SENS	O	FZC and TZC signal output
3	TR2	I	TR2 (I/V conversion amplifier) input	31	XRST	I	Reset signal output
4	PG	GND	Preamplifier block ground	32	DIRC	I	Direct control signal output
5	FH	O	Focus error hold signal output	33	XLT	I	Data transfer signal input
6	TE	I/O	Track error signal output, TM1 input	34	DATA	I	Data signal input
7	TG1	I	TG1 switch	35	CLK	I	Data sync clock input
8	TG2	I	TG2 switch	36	LMSW	I	Limit switch input
9	TS1 $\ominus$	I	TSA1 $\ominus$ input	37	LDSW	I	Laser switch input
10	TS10	O	TSA1 output	38	FOK	O	FOK comparator output
11	TS2 $\ominus$	I	TSA2 $\ominus$ input	39	GEFM	GND	EFM comparator ground
12	TS20	O	TSA2 output	40	EFMC	O	EFM comparator output
13	TM2	I	TM2 input	41	VEFM	Vcc	EFM comparator Vcc
14	SS $\ominus$	I	SSA $\ominus$ input	42	DSLCL	I	Data slice level control input
15	SSO	O	SSA output	43	DFIN	I	Defect comparator input
16	MIRR	O	Mirror comparator output	44	DFO	O	Defect signal output
17	FE	I/O	Focus error signal output, FS4 input	45	DFH	O	Defect hold signal output
18	SG	GND	Servo block ground	46	MIRH	O	Error hold signal output
19	FS $\ominus$	I	SSA $\ominus$ input	47	EFMI	I	EFM signal output
20	FS0	O	FSA input	48	MD	I	APC amplifier input
21	SVCC	Vcc	Servo block Vcc	49	LD	O	APC amplifier output
22	FUD	O	Focus up/down voltage output	50	BVPS	O	Capacitor connection pin for ripple filter
23	VCR	I/O	VCO reference voltage	51	ISET	O	Reference current setting
24	PDIN	I	VCO control voltage input	52	RFO	O	RFS output
25	FRA	O	VCO free-run frequency setting	53	RF $\ominus$	I	RFS $\ominus$ input
26	VVcc	Vcc	VCO Vcc	54	PVcc	Vcc	Pre-block Vcc
27	VCO	O	VCO output	55	RF1	I	RF1 (I/V conversion block) input
28	VGND	GND	VCO ground	56	RF2	I	RF2 (I/V conversion block) input

CD SECTION

SM5840CP (IC201)

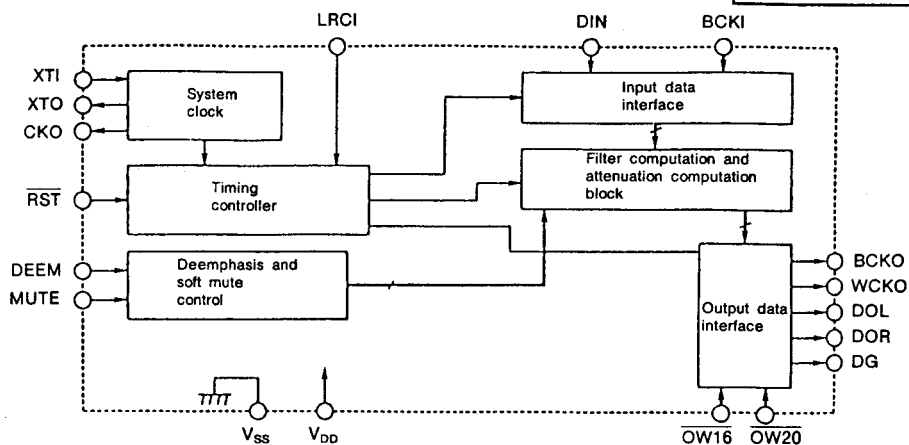
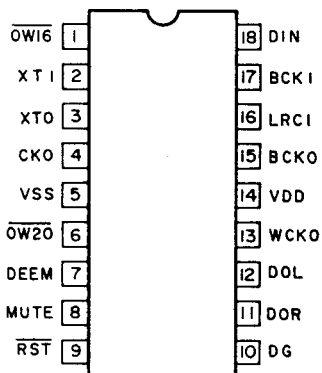
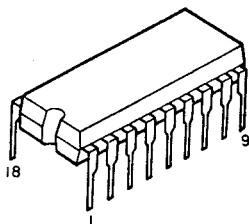

● Pin Description

Pin number DIP	Pin name	i/o	Function		
			Setting	OW20	
				H	L
1	OW16	ip	Selection pin 1 for number of output bits (NOTE) NS-ON : Noise shaper on NS-OFF : Noise shaper off	18bit output (NS-ON)	20bit output (NS-ON)
2	XT1	i	Oscillator input pin		
3	XTO	o	Oscillator input pin		
4	CKO	o	Oscillator output clock (Frequency is the same as XT1)		
5	Vss	-	Ground pin		
	(N.C.)				
	(N.C.)				
6	OW20	ip	Selection pin 2 for number of output bits (NOTE) See the column of OW16.	(When OW20 is low level : 18 bits or 20 bits)	(When OW20 is high level : 18 bits or 16 bits)
7	DEEM	ip	Deemphasis signal input	(When DEM is low level : Deemphasis is off)	(When DEM is high level : Deemphasis is on)
8	MUTE	ip	Mute signal input	(When MUTE is low level : Soft mute is off)	(When MUTE is high level : Soft mute is on)
9	RST	ip	System reset (Initialization)		
10	DG	o	Degitch output		
11	DOR	o	Right channel data output		
12	DOL	o	Left channel data output		
13	WCKO	o	Output word clock		
14	VDD	-	Supply pin (5 V : Standard)		
	(N.C.)				
	(N.C.)				
15	BCKO	o	Output bit clock		
16	LRCI	ip	Clock of the input data sample rate (fs)		
17	BCKI	ip	Input bit clock		
18	DIN	ip	Input data		

i : Input pin    ip : Input pin with pull-up resistor    o : Output pin

BA15218, RC4558  
(IC205, 206, 301)

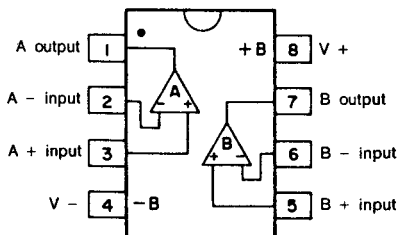
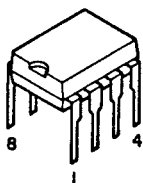

CD SECTION

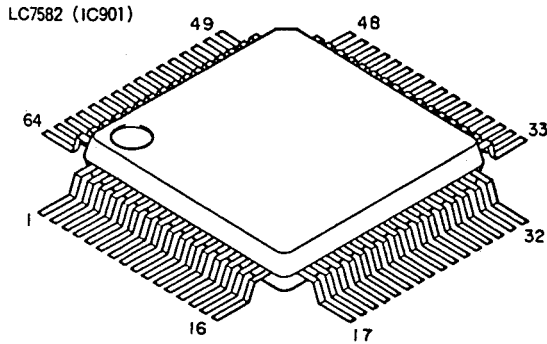

Pin Configuration

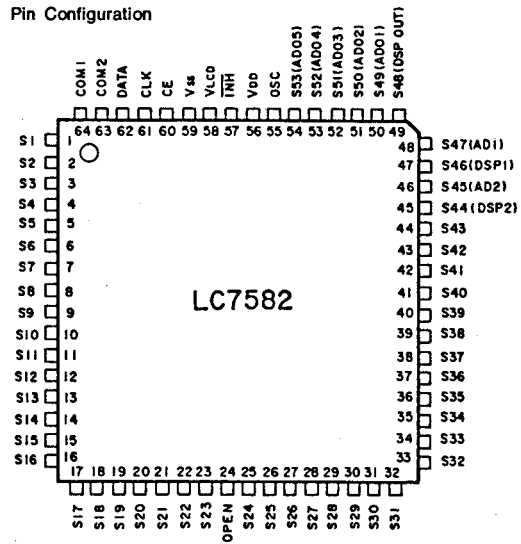

Block Diagram

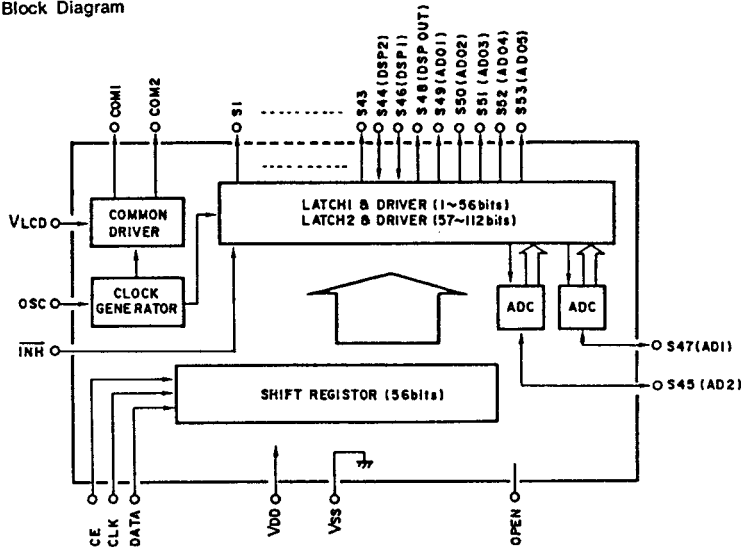

Pin Description

- S1~S13 : Segment output pins
- S46 (DSP1), S44 (DSP2) : Segment output or DSP input pins
- S47 (AD1), S45 (AD2) : Segment output or AD input pins
- S48 (DSPOUT) : Segment output or DSP output pins
- S49~S53 (AD01~5) : Segment output or AD output pins
- COM1,2 : Common output pins (At 1/1 duty, only COM1 is used and COM2 is open)
- V<sub>LCD</sub> : Pin for LCD bias voltage setting
- OSC : Oscillation pin
- CE, CLK, DATA : Input pins for serial data transfer
- V<sub>SS</sub>, V<sub>DD</sub> : Supply pins
- INH : Display-off input pin (Valid only with the output driver. As a result, the transfer of serial data is possible while the display is off.)
- OPEN : No connection



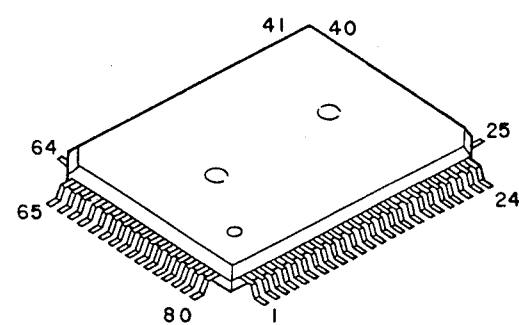

CXD2500AQ (IC701)

● CXD2500AQ Pin Function Table

Pin no.	Pin symbol	I/O	Pin description
1	FOK	I	Focus OK input pin. Used in SENS output and the servo auto sequencer.
2	FSW	O	Z.0 Output filter switching output of the spindle motor.
3	MON	O	1.0 On-off control output of the spindle motor.
4	MDP	O	1,Z.0 Servo control of the spindle motor.
5	MDS	O	1,Z.0 Servo control of the spindle motor.
6	LOCK	O	1.0 Samples GFS at 460 Hz. When GFS is "H", H is output. L is output when there is "L", 8 times in succession.
7	NC	—	
8	VCOO	O	1.0 Oscillation circuit output for analog EFM PLL.
9	VCOI	I	Oscillation circuit output for analog EFM PLL. $f_{LOCK} = 8.6436$ MHz.
10	TEST	I	Test pin, always grounded.
11	PDO	O	1,Z.0 For charge pump used with analog EFM PLL.
12	Vss		Ground
13	NC	—	
14	NC	—	
15	NC	—	
16	VPCO	O	1,Z.0 PLL charge pump output used for vari-pitch.
17	VCKI	O	Clock input $f_{CENTER}$ from the external VCO for varipitch equals 16.9344 MHz.
18	FILO	O	Analog Filter output (slave = digital PLL) for master PLL.
19	FILI	I	Filter input for master PLL.
20	PCO	O	1,Z.0 Charge pump output for master PLL.
21	AVss		Analog ground.
22	CLTV	I	VCO control voltage input for master.
23	AVDD		Analog supply (+5 V)
24	RF	I	EFM signal input
25	BIAS	I	Grounded
26	ASYI	I	Grounded
27	ASYO	O	1.0 EFM full-swing output. (L = Vss, H = VDD)
28	ASYE	I	Grounded
29	NC	—	
30	PSSL	I	Switching input for the audio data output mode. Serial output with "L" and parallel output with "H".
31	WDCK	O	1.0 D/A interface for 48-bit slot. Word clock $f = 2Fs$ .
32	LRCK	O	1.0 D/A interface for 48-bit slot. LR clock $f = Fs$ .
33	VDD		Supply (+5 V)

Pin no.	Pin symbol	I/O	Pin description
34	DA16	O	1.0 DA16 (MSB) output when PSSL = 1. Serial data of the 48-bit slot when PSSL = 0. (2s' COMP, MSB first.)
35	DA15	O	1.0 DA15 output when PSSL = 1. Bit clock of the 48-bit slot when PSSL = 0.
36	DA14	O	1.0 DA14 output when PSSL = 1. Serial data of the 64-bit slot when PSSL = 0. (2s' COMP, LSB first.)
37	DA13	O	1.0 DA13 output when PSSL = 1. Bit clock of the 64-bit slot when PSSL = 0.
38	DA12	O	1.0 DA12 output when PSSL = 1. LR clock of the 64-bit slot when PSSL = 0.
39	DA11	O	1.0 DA11 output when PSSL = 1. GTOP output when PSSL = 0.
40	DA10	O	1.0 DA10 output when PSSL = 1. XUGF output when PSSL = 0.
41	DA09	O	1.0 DA09 output when PSSL = 1. XPLCK output when PSSL = 0.
42	DA08	O	1.0 DA08 output when PSSL = 1. GFS output when PSSL = 0.
43	DA07	O	1.0 DA07 output when PSSL = 1. RFCK output when PSSL = 0.
44	DA06	O	1.0 DA06 output when PSSL = 1. C2PO output when PSSL = 0.
45	DA05	O	1.0 DA05 output when PSSL = 1. XRAOF output when PSSL = 0.
46	DA04	O	1.0 DA04 output when PSSL = 1. MNT3 output when PSSL = 0.
47	DA03	O	1.0 DA03 output when PSSL = 1. MNT2 output when PSSL = 0.
48	DA02	O	1.0 DA02 output when PSSL = 1. MNT1 output when PSSL = 0.
49	DA01	O	1.0 DA01 output when PSSL = 1. MNT0 output when PSSL = 0.
50	APTR	O	1.0 Control output for aperture correction. "H" with Rch.
51	APTL	O	1.0 Control output for aperture correction. "H" with Lch.
52	Vss		Ground
53	XTAI	I	16.9344 MHz x'tal oscillator circuit input. Or 33.8688 MHz input.
54	XTAO	O	1.0 16.9344 MHz x'tal oscillator circuit input.
55	XTSL	I	X'tal selection input pin. "L" when the x'tal is 16.9344 MHz and "H" when the x'tal is 33.8688 MHz.
56	FSTT	O	1.0 2/3 frequency division output of pins 53 and 54. Does not change with vari-pitch.
57	C4M	O	1.0 4.2336 MHz output. Changes simultaneously when varypitch is applied.
58	C16M	O	1.0 16.9344 MHz output. Changes simultaneously when varypitch is applied.
59	MD2	I	Digital-Out on/off control. H when on and L when off.
60	DOUT	O	1.0 Digital-out output pin.
61	EMPH	O	1.0 When the playback disc has emphasis. "H" is output. "L" is output when there is no emphasis.
62	WFCK	O	1.0 WFCK (Write Frame Clock) output.
63	SCOR	O	1.0 "H" output when either sub code sync S0 or S1 is detected.
64	SBSO	O	1.0 Sub P through W serial output.
65	EXCK	I	Clock input for SBSO read-out use.
66	SQSO	O	1.0 SubQ 80 bit and PCM peak level data 16-bit output.
67	SQCK	I	Clock input for SQSO read-out use.
68	MUTE	I	Mute L is cancelled with H.
69	SENS	—	1,Z.0 SENS output. Output to CPU.
70	XRST	I	System set. Reset with "L".
71	DATA	I	Serial data input from CPU.
72	XLAT	I	Latch input from CPU. Latches serial data on the fall.
73	VDD		Supply (+5 V)
74	CLOK	I	Serial data transfer clock input from CPU.
75	SEIN	I	Sense input from SSP.
76	CNIN	O	Count signal input of number of track jumps.
77	DATO	O	Serial data output to SSP.
78	XLTO	O	1.0 Serial data latch output to SSP. Latches on the fall.
79	CLKO	O	1.0 Serial data transfer clock output to SSP.
80	MIRR	I	Mirror signal input. Used in jumps of 128 tracks or more with an auto sequencer.

CD SECTION

μPD75116GF-E16-3BE (IC601)

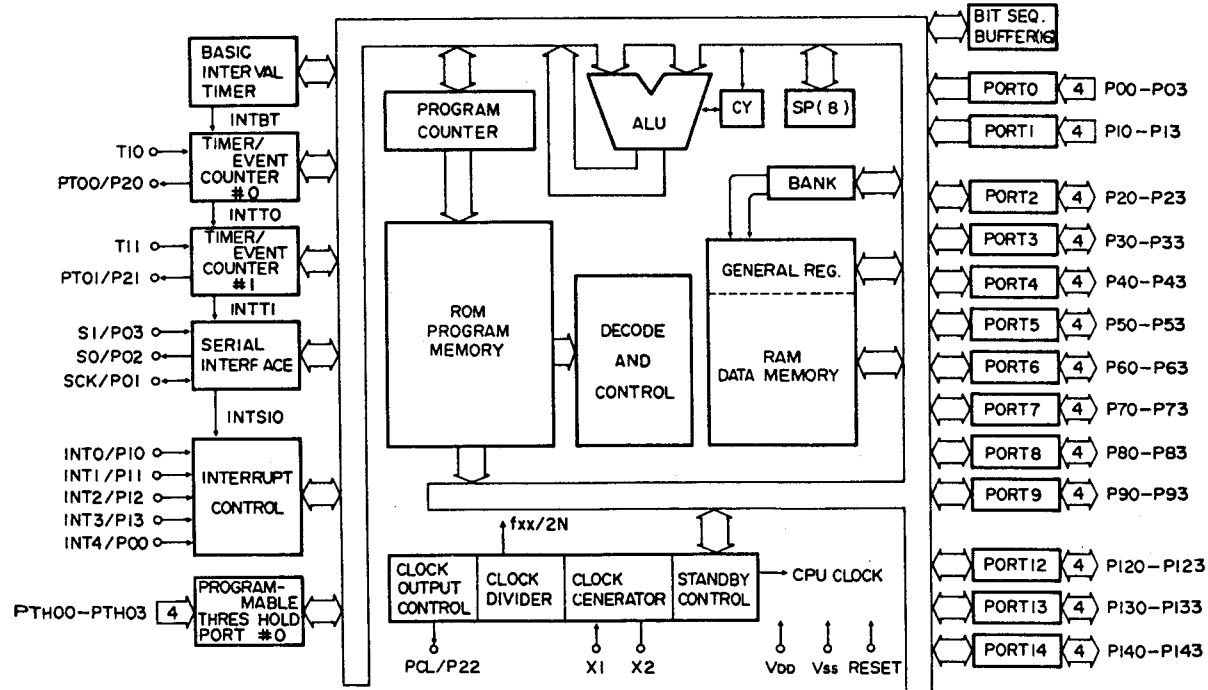
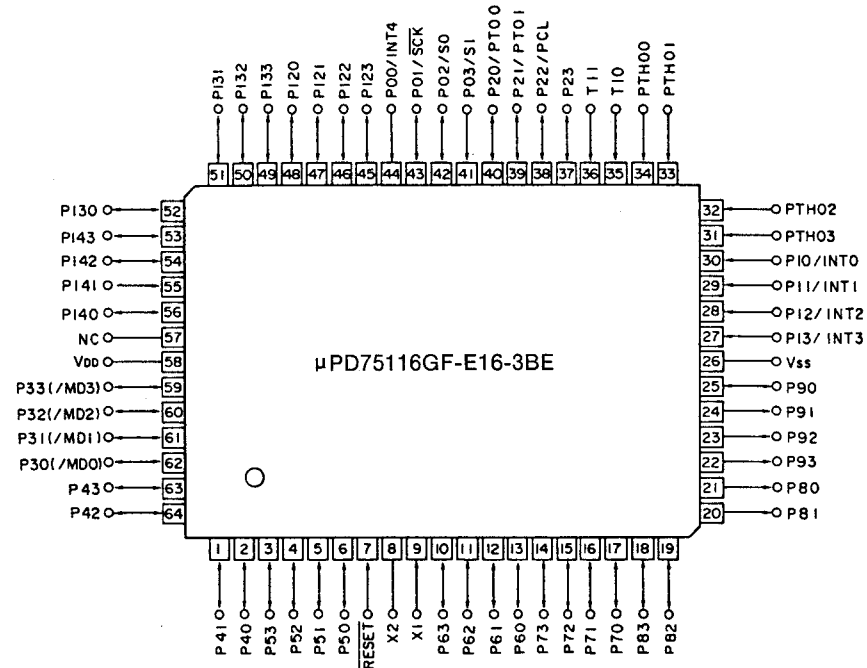
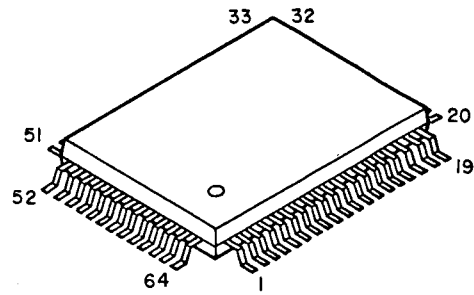

Pin	Pin name	Signal name	I/O	Active	Initial	Description	Pin	Pin name	Signal name	I/O	Active	Initial	Description
1	P41	NC	O	-	L	Open	33	PTH01	PKR3	I	H	L	Key return
2	P40	POSPRES	O	H	L	Reset signal (10 ms) (with vary on) for DPS	34	PTH00	PKR4	I	H	L	Key return
3	P53	NC	O	-	L	Open	35	T10	PSENSE	I	-	H	Servo state detection signal
4	P52	NC	O	-	L	Open	36	T11	NC	I	-	H	Ground
5	P51	PS9	O	H	L	Diode key scan signal	37	P23	PSVCDAT	O	-	H	Servo control signal and data for D.F.
6	P50	PS8	O	H	L	Momentary key scan signal 8	38	P22/PCL	PSVCLT	O	LP	H	Servo control signal latch.
7	RESET	RESET	I			Microprocessor reset pin.	39	P21/PT01	PSVCLK	O	-	H	Servo control signal and clock for D.F.
8	X2	μCONCLK	O			Microprocessor clock	40	P20/PT00	PLASER	O	L	H	Laser diode on/off control.
9	X1	μCONCLK	I			Microprocessor clock	41	P03/SI	PSUBQ	I	-	H	Sub code data input.
10	P63	PKS7	O	H	L	Momentary key scan signal 7	42	P02/SO	NC	O	-	-	Open
11	P62	PKS6	O	H	L	Momentary key scan signal 6	43	P01/SCK	PSQCK	O	-	H	Clock for sub code reading.
12	P61	PKS5	O	H	L	Momentary key scan signal 5	44	P00/INT4	PREM	I	↑↓	L	Remote control signal input.
13	P60	PKS4	O	H	L	Momentary key scan signal 4	45	P123	PDFLT	O	LP	H	Latch signal for digital filter.
14	P73	PKS3	O	H	L	Momentary key scan signal 3	46	P122	PAMUT	O	H	H	Audio mute control signal.
15	P72	PKS2	O	H	L	Momentary key scan signal 2	47	P121	PEMP	O	L	H	Signal with emphasis control.
16	P71	PKS1	O	H	L	Momentary key scan signal 1	48	P120	PDIRC	O	LP	H	Servo control signal.
17	P70	PKS0	O	H	L	Momentary key scan signal 0	49	P133	PMVCL	O	L	H	Disc tray drive signal.
18	P83	NC	O	-	L	Open	50	P132	PMVOP	O	L	H	Disc tray drive signal.
19	P82	NC	O	-	L	Open	51	P131	PDMUT	O	H	H	Mute output for LSI.
20	P81	NC	O	-	L	Open	52	P130	PAFSO	O	-	H	Auto function serial output.
21	P80	NC	O	-	L	Open	53	P143	PFOK	I	H	L	FOCUS OK signal input.
22	P93	PTINIT	O	H	L	Test pin	54	P142	PSWOPN	I	L	H	Disc tray open position detection.
23	P92	PTEDIT	O	H	L	Test pin	55	P141	PSWCLS	I	L	L	Disc tray close position detection.
24	P91	PTSARCH	O	H	L	Test pin	56	P140	PSWPMD	I	L	-	Pickup inner track position detection.
25	P90	PDOUT	O	H	L	Digital output control signal	57	NC	NC				Open
26	Vss	Vss				Ground potential pin	58	Vdd	Vdd				Positive voltage supply pin. (+5 V)
27	P13/INT3	NC	I	-	H	Pull-up	59	P33	PLCDOF	O	L	L	Display-off output signal for LCD driver.
28	P12/INT2	PGFS	I	H	L	Rotation sync signal input from DPS.	60	P32	PLCDCE	O	H	L	Latch signal for LCD driver.
29	P11/INT1	PSCOR	I	↑↓	L	Sub code sync signal input.	61	P31	PLCDCLK	O	-	L	Clock for LCD driver.
30	P10/INT0	PAFSI	I	-	H	Auto function real signal input.	62	P30	NC	O	-	L	Open
31	PTH03	PKR1	I	H	L	Key return	63	P43	NC	O	-	L	Open
32	PTH02	PKR2	I	H	L	Key return	64	P42	PLCDDAT	O	-	L	Data for LCD driver.

LP = LOW pulse

CD SECTION

PCM61P-L (IC203, 204)

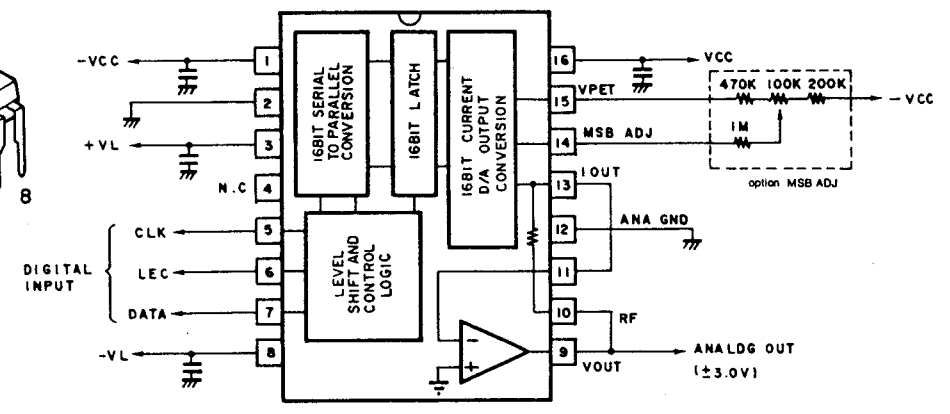
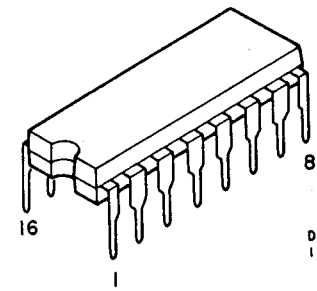

BA6290A (IC402, 403)

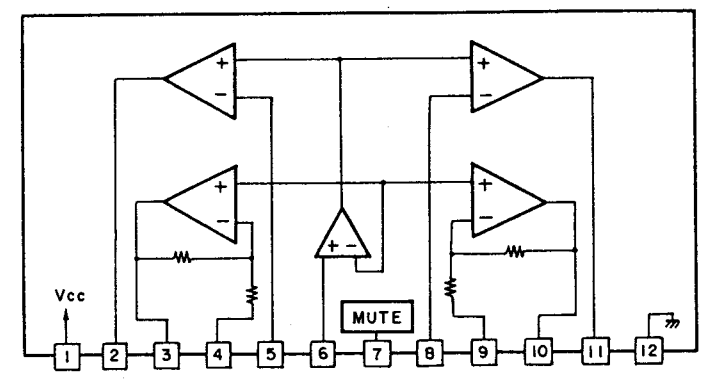
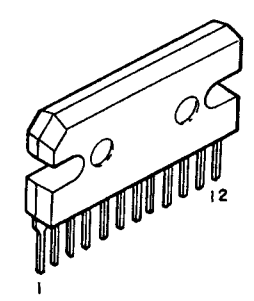

M5290P (IC503)

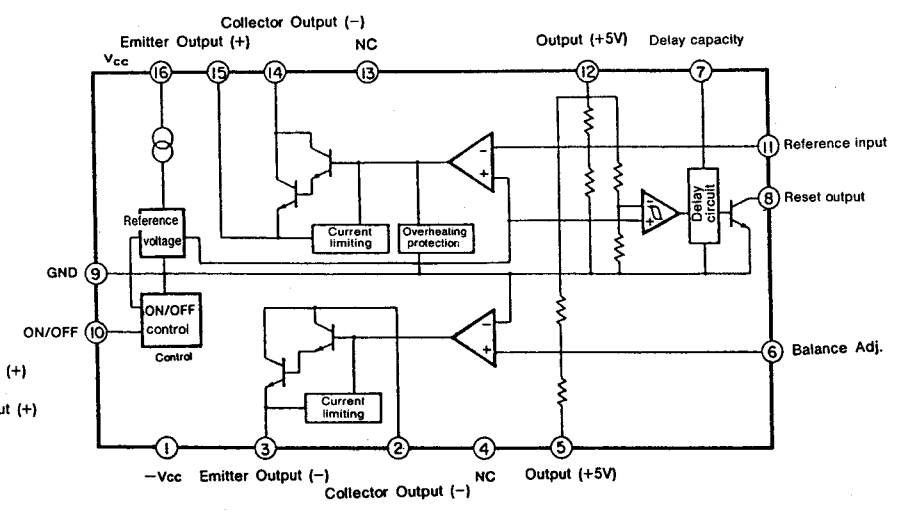
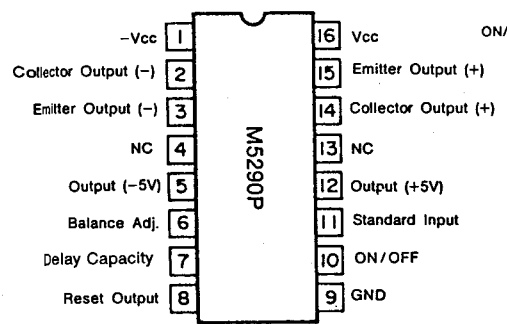
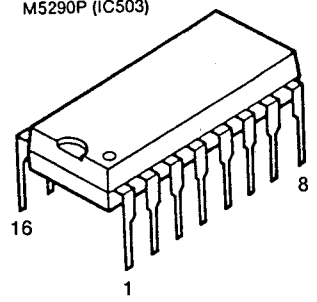

IC PROTECTOR ICP-N15 (IC501, 502)

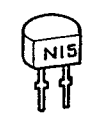

Transistors

2SA1015 (GR)

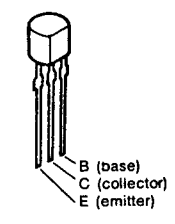

2SD562 (C), BC369  
2SD468 (C), BC368

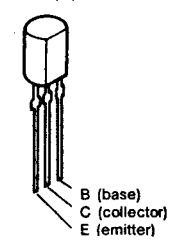

2SB1274  
2SD1913

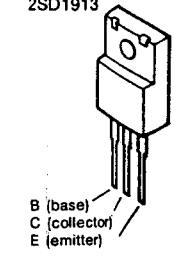

DTA114ES PNP Type  
DTC114ES } NPN Type  
DTC144ES }

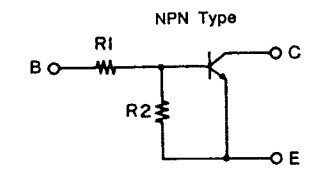
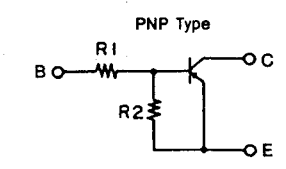
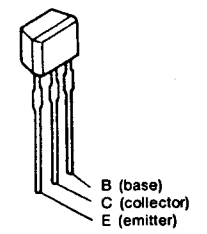

	R1	R2
DTA114ES	10k ohm	10k ohm

	R1	R2
DTC114ES	10k ohm	10k ohm
DTC144ES	47k ohm	47k ohm
DTC314TS	10k ohm	-

Diodes (included LED)

1SS270A



1SR139-200

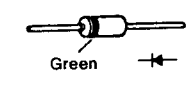

DTC314TS

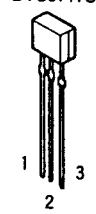

(1) Emitter E  
(2) Collector C  
(3) Base B

HZS6B-2

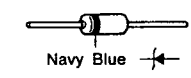

SLR-34MC70F120G (Green)

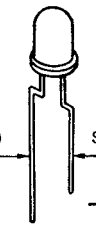

Long (Anode) Short (Cathode)

LED Ass'y

Part No.: 3939493002 (LE901)

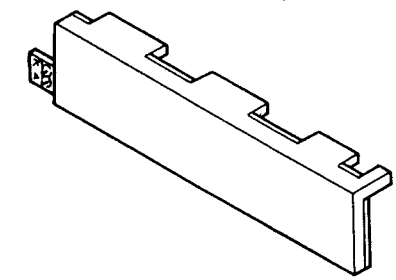

Wiring Diagram

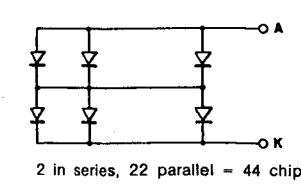

CD SECTION

● LCD Ass'y (8155JPH)

Part No.: 3934105007

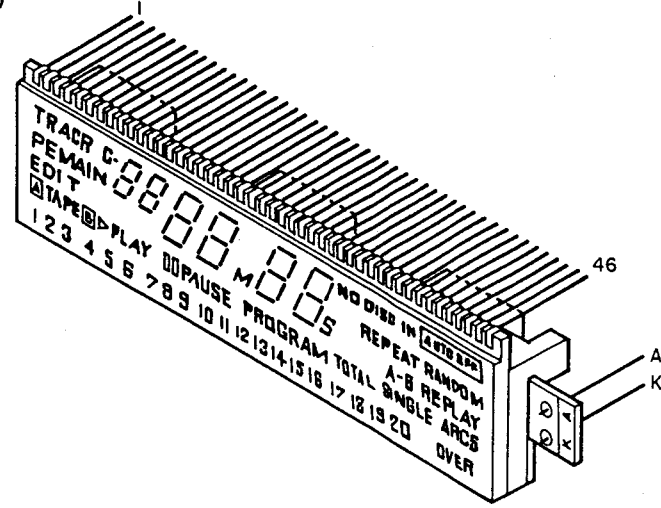

TRACK C- 0000 NO DISC IN AUTO OFF  
 REMAIN 0000 M 00 S REPEAT RANDOM  
 EDIT A-B REPLAY  
 [A] TAPE [B] ▷ PLAY [ ] PAUSE PROGRAM TOTAL SINGLE ARCS  
 1 2 3 4 5 6 7 8 9 10 11 12 13 14 15 16 17 18 19 20 OVER

NO.	1	2	3	4	5	6	7	8	9	10	11	12	13	14	15	16	17	18	19	20	21	22	23
COM1	-	COM	6	PAUSE	4	B	2	TRACK	A	C-	1f	1a	1b	2d	2a	2g	3d	3e	3a	3b	4e	4f	4b
COM2	COM	-	5	PLAY	3	TAPE	1	REMAIN	EDIT	1d	1e	1g	1c	2e	2f	2b	2c	3f	3g	3c	4d	4a	4g
NO.	24	25	26	27	28	29	30	31	32	33	34	35	36	37	38	39	40	41	42	43	44	45	46
COM1	M	TOTAL	5e	5f	5a	5c	6f	6a	6b	17	B	DISC	IN	SINGLE	ARCS	RANDOM	AUTO	20	16	14	12	10	8
COM2	4c	PROGRAM	5d	5g	5b	6d	6e	6g	6c	S	A-	NO	REPEAT	18	OVER	REPLAY	OFF	19	15	13	11	9	7

SCHMATIC DIAGRAM

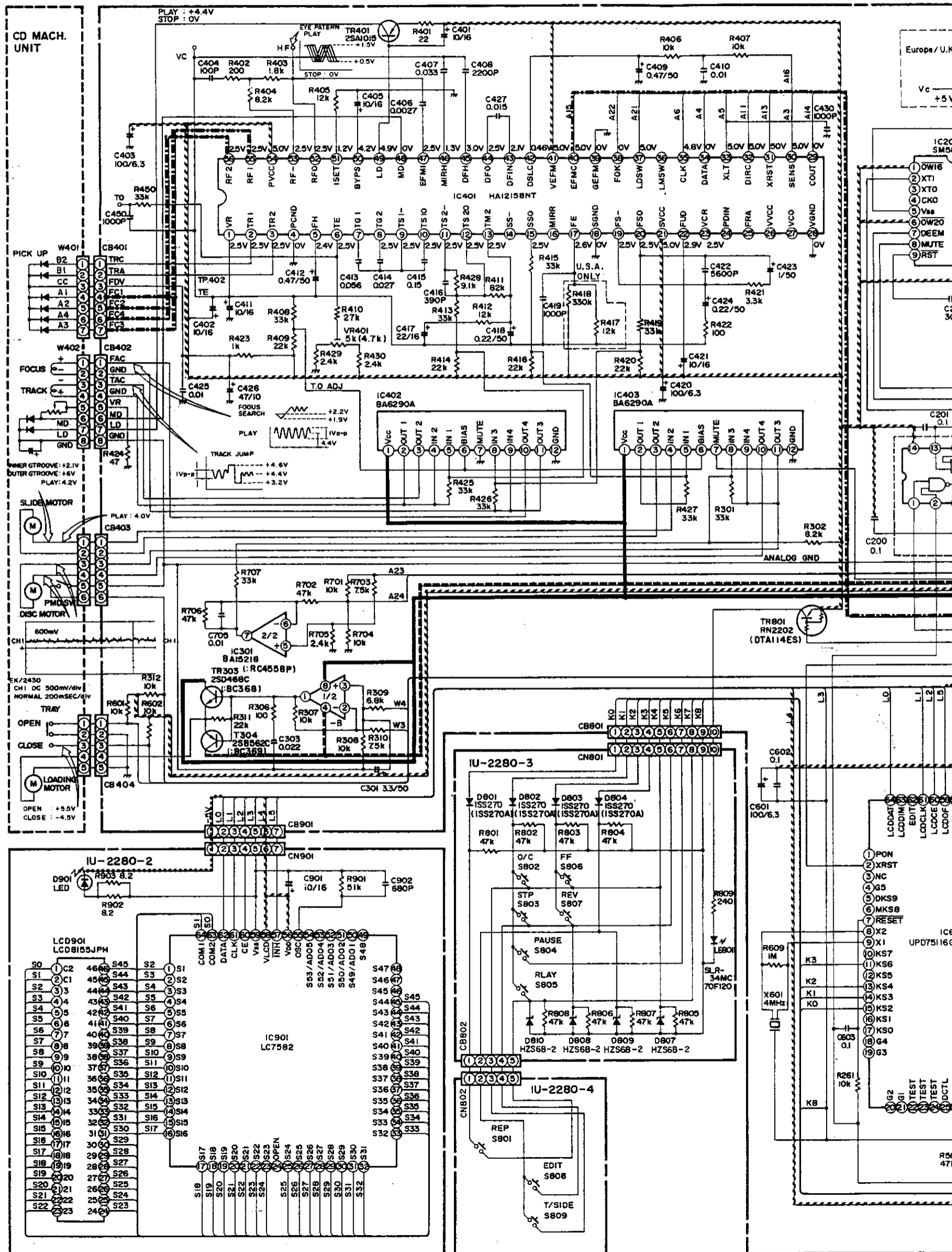

NOTE: Figures in parentheses are for the UCD-70 Europe/BK.

SCHEMATIC DIAGRAM

5 6 7 8 9 10

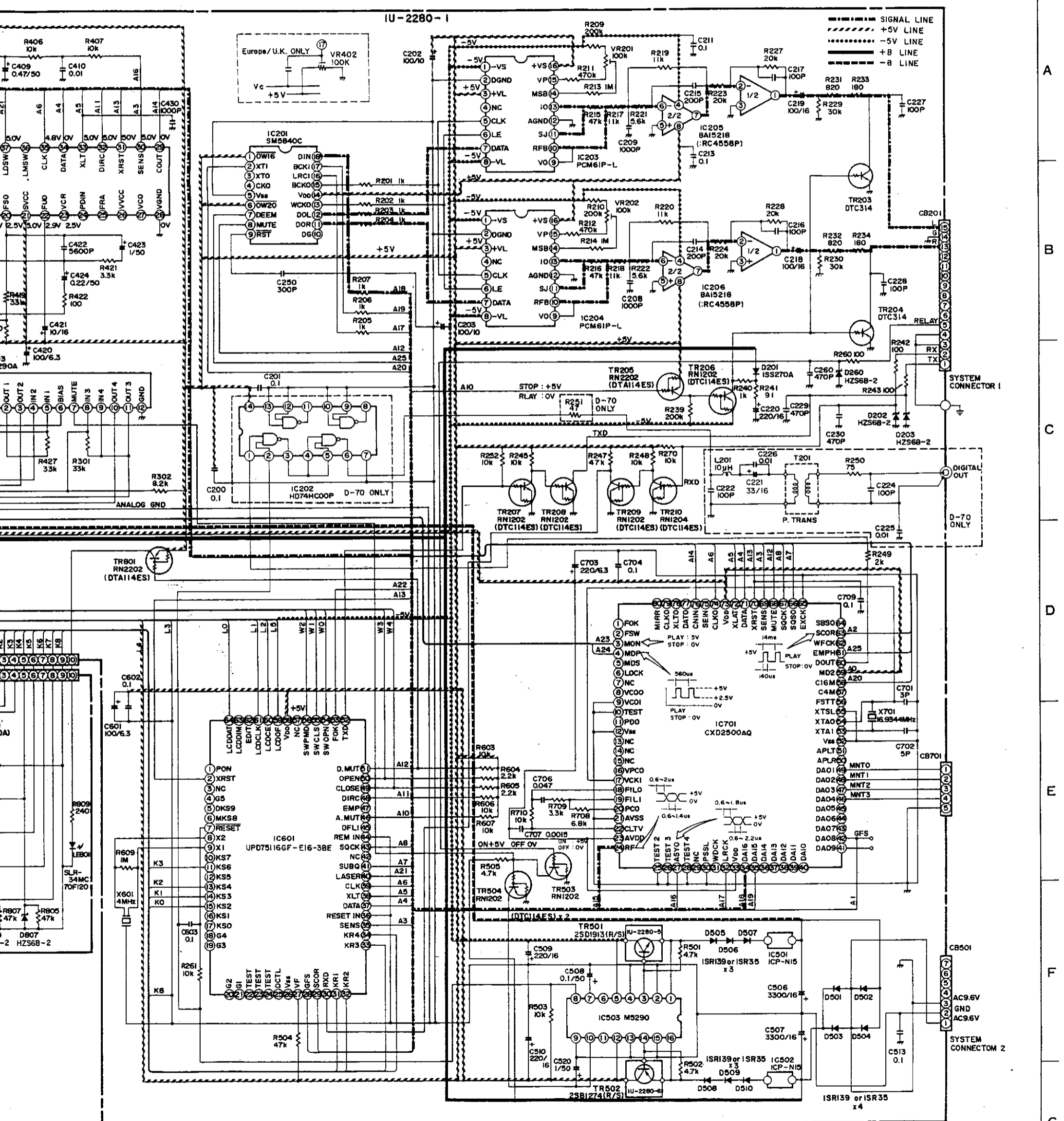

NOTES  
 ALL RESISTANCE VALUES IN OHM K=1,000 OHM M=1,000,000 OHM EACH VOLTAGE AND CURRENT ARE MEASURED AT NO SIGNAL INPUT CONDITION.  
 ALL CAPACITANCE VALUES IN MICRO FARAD P=MICRO-MICRO FARAD CIRCUIT AND PARTS ARE SUBJECT TO CHANGE WITHOUT PRIOR NOTICE.

A  
B  
C  
D  
E  
F  
G

CD SECTION

EXPLODED VIEW OF PARTS LIST

Ref. No.	Part No.	Part Name	Remarks	Qty
1	411 1099 139	Chassis		1
2	105 0973 225	Rear Panel		1
3	104 0253 010	Foot Ass'y		4
4	415 9016 019	P.C.B Holder		2
5	-	-		-
6	1U- 2280 A	CD Unit Ass'y		1 <sup>s</sup>
6-1	-	Main Unit		(1)
6-2	-	LCD Unit		(1)
6-3	-	Tact Switch Unit		(1)
6-4	-	Tact Switch Unit		(1)
7	-	-		-
8	393 4105 007	LCD Ass'y	LC901	1
9	254 4255 704	Chemicon 3300 $\mu$ F/16V	C506.507	2
10	337 0015 007	CD Mech. Unit		1
11	103 1469 101	Mech.Holder (A)		3
12	146. 1283 216	Loader Panel (C) Ass'y		1
13	144 2134 041	Front Panel		1
14	103 1471 335	Inner Panel Ass'y		1
15	435 0113 009	Latch (Y3Y18)		1
16	143 0742 102	Lens		1
17	113 1458 119	Control Button		1
18	144 2133 110	Trap Door		1
19	401 0126 200	Door Hinge (L)		1
20	401 0127 209	Door Hinge (R)		1
21	146 1279 110	Side Panel (L) Ass'y		1
22	146 1281 111	Side Panel (R) Ass'y		1
23	102 0478 132	Top Cover		1
24	513 1863 056	Rating Sheet		1
25	262 1456 206	$\mu$ PD75116GF-E16-3BE	$\mu$ -Com	1
26	449 0055 302	LCD Holder		1
27	204 2429 003	7P System Socket	CB501	1
28	204 8284 022	15P System Socket	CB201	1
29	122 0146 002	Himeron Sheet	Put on F/Panel	1
★ 30	513 1513 005	Laser Caution	Europe model only	1
★ 31	513 0985 003	Inst. Label	Europe model only	2
★ 32	461 0577 068	Rubber Sheet		1
<b>SCREWS</b>				
71	473 7002 034	Tapping Screw (S) 3X6	Black	19
72	473 7500 015	Tapping Screw (P) 3X8		6
73	473 7002 021	Tapping Screw (S) 3X8	Black	2
74	473 7007 000	Tapping Screw (S) 4X8	Black	4
76	473 7500 044	Tapping Screw (P) 3X8	Black	2
77	473 7015 018	Tapping Screw (S) 3X8	Black for GND	1
78	425 0232 006	Adjust Washer	t0.3 Black	1
79	425 0232 019	Adjust Washer	t0.5 Clear	1
<b>PACKING &amp; ACCESSORIES (Not included EXPLODED VIEW)</b>				
101	505 0154 082	Cabinet Cover	600X600	1
102	-	-		-
103	503 0980 001	Cushion		2
104	501 1560 013	Sleeve Carton		1
105	GEN 1785	Envelope Sub Ass'y		1 <sup>s</sup>
105-1	505 0178 000	:Poly Cover	255X380	(1)
105-2	511 2224 009	Inst. Manual		(1)
105-3	511 2264 001	Inst. Manual (3)		(1)
106	GEN 1789	Acc. Carton Sub Ass'y		1 <sup>s</sup>
106-1	501 9195 008	Accessory Carton		(1)
106-2	231 0922 009	Loop Antena		(1)
106-3	395 0019 025	FM Ant. Ass'y		(1)
106-4	529 0072 005	FM AntAdaptor		(1)
106-5	399 0144 002	Remote Control	RC-142	(1)
106-6	204 2483 007	7P System Connector Cord		(1)
106-7	204 6318 013	15P System Connector Cord		(1)
107	513 1389 006	Control Card Base		1
108	513 1349 004	Thermal Carbon Film		1

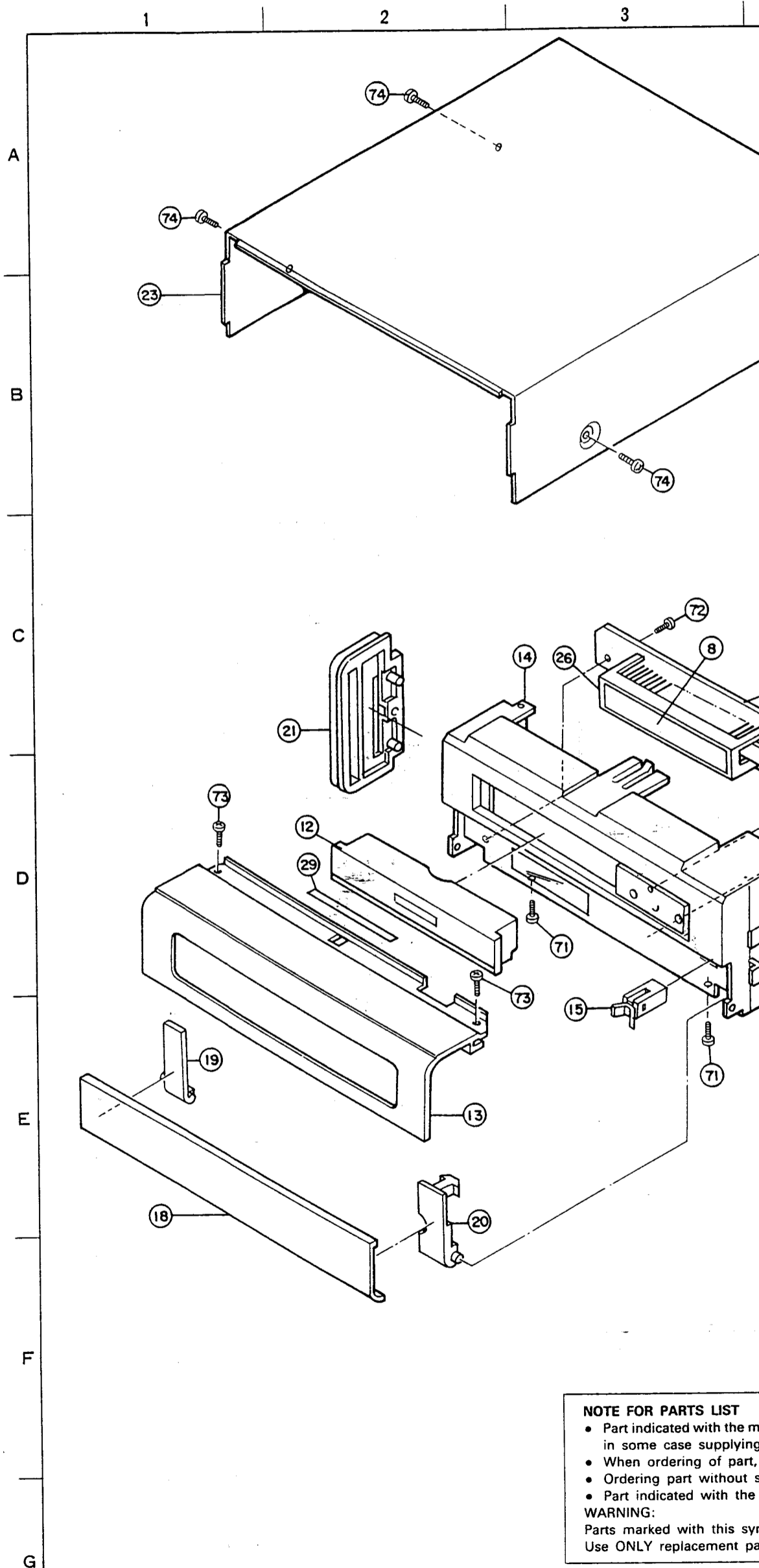

EXPLODED VIEW

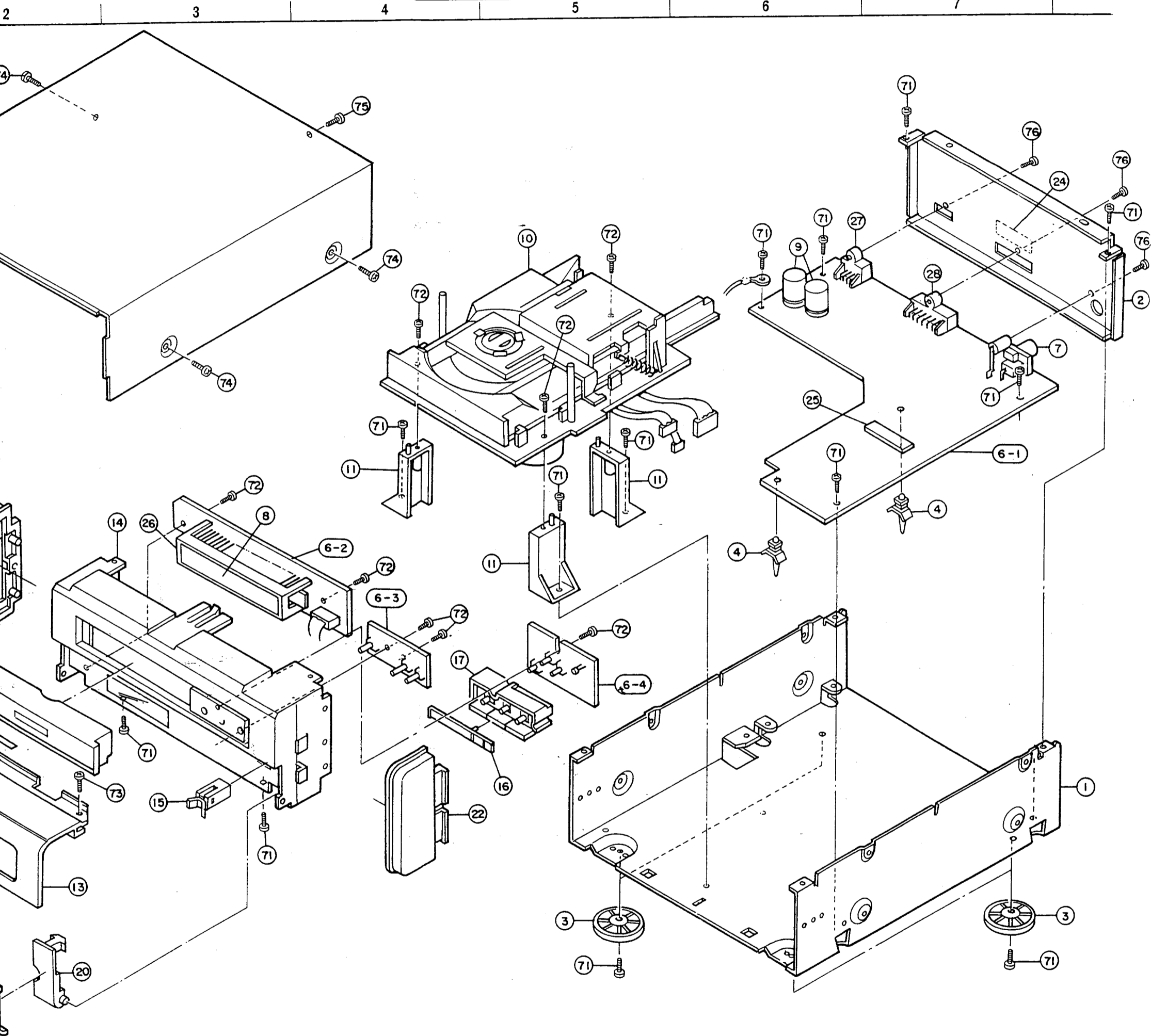

**NOTE FOR PARTS LIST**

- Part indicated with the mark "⊙" are not always in stock and possibly to take a long period of time for supplying, or in some case supplying of part may be refused.
- When ordering of part, clearly indicate "1" and "1" (i) to avoid mis-supplying.
- Ordering part without stating its part number can not be supplied.
- Part indicated with the mark "★" is not illustrated in the exploded view.

**WARNING:**

Parts marked with this symbol  $\Delta$   have critical characteristics. Use ONLY replacement parts recommended by the manufacturer.



CD SECTION

DISASSEMBLY OF CD MECHANISM

Part No.: 337 0015 007

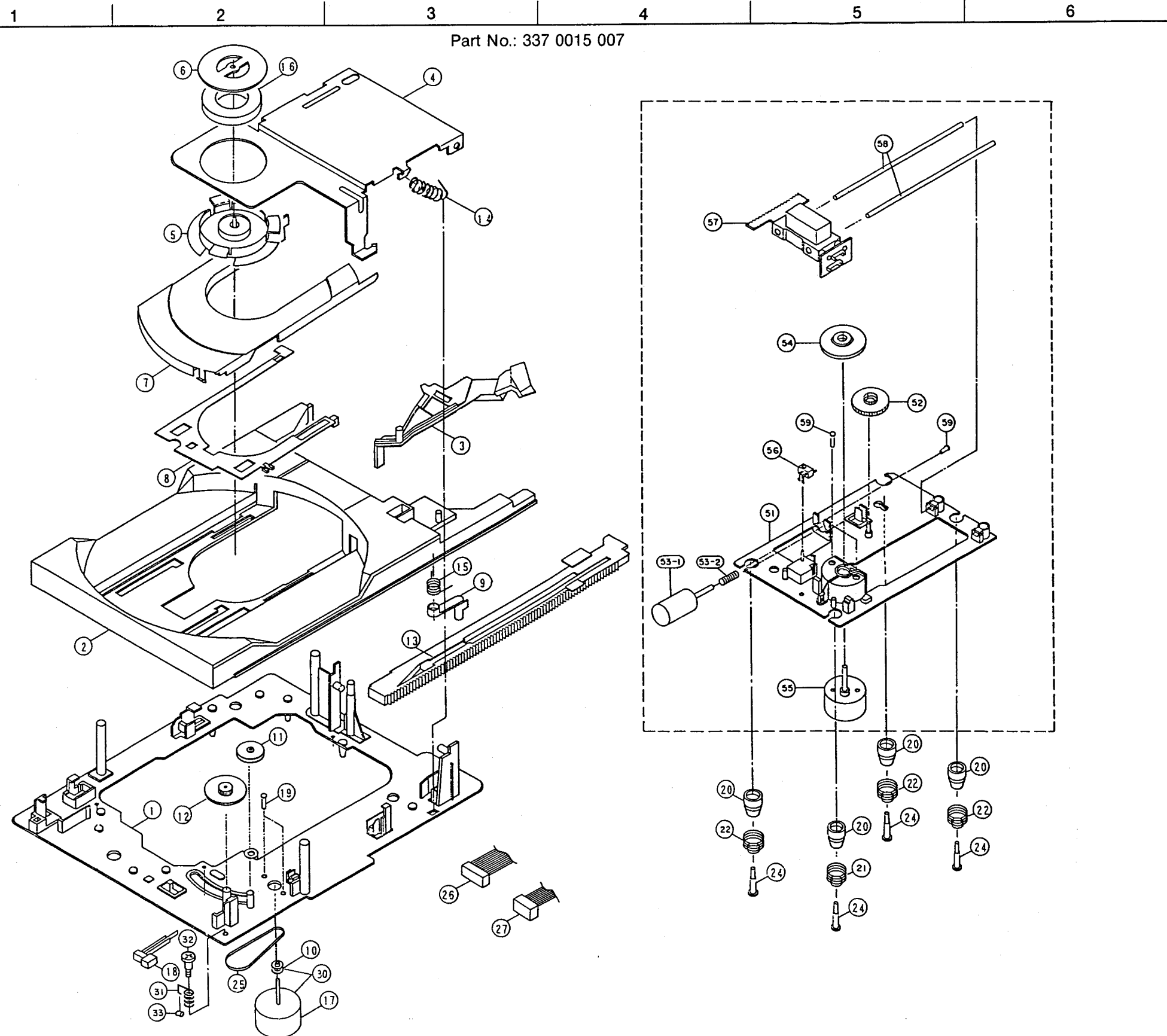

CD MECH. EXPLODED VIEW OF PARTS LIST : 337 0015 007

Ref. No.	Part No.	Part Name	Remarks	Qty
1	9KA 81A2 95	Loading Plate OS		1
2	9KA 81G9 73	Tray 201		1
3	9KA 81G9 74	Switch Lever		1
4	9KA 81P4 62	Clamper Arm		1
5	9KA 81G9 75	Clamper		1
6	9KA 81P4 63	Clamper Plate		1
7	9KA 81G9 76	Disc Holder		1
8	9KA 81G9 77	Lifter Cam		1
9	9KA 81G9 78	Latch		1
10	-	Motor Pulley		1
11	9KA 81G1 22	Pulley Gear		1
12	9KA 81G1 23	Gear		1
13	9KA 81G5 81	Rack 11B		1
14	9KA 81S0 59	Clamp Spring		1
15	9KA 81S0 60	Latch Spring		1
16	9KA 82G0 57	Clamper Magnet		1
17	-	Motor MDN-4RA3EZAS		1
18	9KS 01W1 32	Leaf Switch SWL5C122343AU	Loading Limit Switch SW	1
19	9KM 20S0 04	M2X4 Screw		2
20	9KA 82G0 56	Floating Rubber M3		4
21	9KA 81S0 66	Floating Spring SPM3A		1
22	9KA 81S0 67	Floating Spring SIM3B		3
23	-	-		-
24	9KA 81H0 85	Floating Screw C		4
25	9KA 82G1 80	Floating Belt (Square)	1.4X18.1	1
26	9KA 82G1 23	Connector Wire 6P	CNW6PM3	1
27	9KA 82G1 24	Connector Wire 5P	CNW5PM3	1
28	-	-		-
29	-	-		-
30	9KA 81A3 08	Loading Motor Ass'y	with 10, 17	1
31	9KA 81S0 71	Tray Spring		1
32	9KA 82H0 35	Tray Spring Fixing Screw		1
33	9KA 82G1 84	Tube		1
51	9KA 81A2 93	Spindle Motor Ass'y	Includ T/M, Unit Plate	1
52	9KA 81G9 66	Slide Gear T		1
53	9KA 81A2 90	Feed Motor Ass'y		1
53-1	-	Feed Motor RD-050Y		(1)
53-2	-	Warm Gear T		(1)
54	-	Turn Table Ass'y		1
55	-	S Motor RF-310T114B		1
56	9KS 01W0 56	Push Switch-SPPB-11	Head Sent Limit Switch SW	1
57	9KH 0PM3	Optical Pick Up Ass'y HOP-M3		1
58	9KA 81H1 07	Slide	Slide Shaft	2
59	9KM 20N0 03	M2X3 Pan Screw		4