

DENON

Hi-Fi Personal Component System

SERVICE MANUAL PERSONAL COMPONENT SYSTEM MODEL D-65

Europe Model

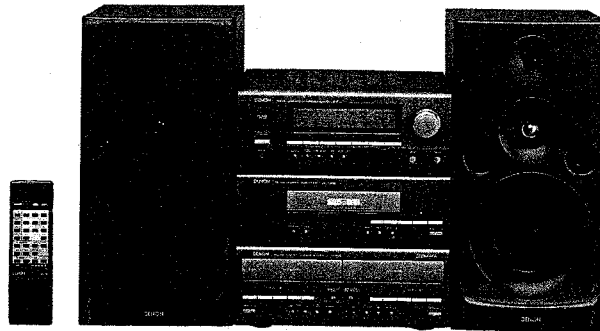

MAIN FEATURES

- **Quality power designed for high sound quality**
30W + 30W high quality power amplifier.
- **Multi-function CD player with a full set of functions**
Editing function for automatically dividing the tracks on CDs for recording onto sides A and B of a tape.
Pick function for edited recording keeping the blank section at the end of the tape as short as possible.
- **Dolby B and C Noise Reduction**
Playback and recording with high sound quality.
- **Three-course timer**
Three timer settings are possible: Everyday, Sleep and Once.
- **Surround circuit**
Sound with a strong sense of presence.
- **Three-way speakers**
13cm woofer, 5cm tweeter and 2.5cm tweeter (antimagnetic type) designed for high sound quality.

BEFORE USING

Note the following points before using the D-65.

- **Moving the system**
To prevent short-circuiting or damage of the connection cords, be sure to unplug the power cord and disconnect all connection cords before moving the system.
In addition, always remove CDs before moving the system. Failing to do so may result in scratched CDs.
- **Before switching on the power**
Check again that all connections are proper and that the connection cords are not damaged. Be sure to disconnect the power plug before disconnecting or connecting the connection cords.
- Hum may be produced if a TV set or another audio component is set near this system or their connection cords are nearby. If this happens, try changing the position of the equipment and connection cords.
- Do not move the system abruptly from a cold place to a warm place, since this may cause water droplets (condensation) to form in the equipment, preventing proper operation. If this happens, wait one hour before using the system.

Check that the following parts are included in the package aside from the main unit:

- ① Operating Instructions 1
- ② FM Antenna 1
- ③ AM Loop Antenna 1
- ④ Remote Controller (RC-164) 1
- ⑤ R6P/AA Batteries 2

NIPPON COLUMBIA CO., LTD.

GENERAL SECTION

TABLE OF CONTENTS

General Section (Page 1 ~ Pages 30)

• Main Features	1
• Before Using	1
• Main Specifications	3
• Operating Instructions	4~30

Receiver Section (Pages 31 ~ Pages 51)

• Block, Level Diagram	31
• Disassembly Procedures	32, 33
• Adjustment	34, 35
• Semiconductors	36~39
• Microprocessor Documentation	40, 41
• Microprocessor Peripheral Wiring Diagram	42
• Printed Wiring Board, Parts List	43~47
• Wiring Diagram	48
• Schematic Diagram	49
• Exploded View, Parts List	50
• Remote Control Unit	51

CD Player Section (Pages 52 ~ Pages 77)

• Disassembly Procedures	52
• Block Diagram	53
• Laser Pickup	54
• Service Points	55~57
• Adjustment Method	58~61
• Semiconductors	62~67
• Microprocessor Documentation	68
• Microprocessor Peripheral Wiring Diagram	69
• Printed Wiring Board, Parts List	70~73
• Wiring Diagram	74
• Schematic Diagram	75
• Exploded View, Parts List	76
• Disassembly of CD Mechanism	77

Cassette Deck Section (Pages 78 ~ Pages 99)

• Disassembly Procedures	78, 79
• Level Diagram	80
• Block Diagram	81
• Adjustment	82, 83
• Semiconductors	84, 85
• Microprocessor Documentation	86~88
• Microprocessor Peripheral Wiring Diagram	89
• Printed Wiring Board, Parts List	90~93
• Wiring Diagram	94
• Schematic Diagram	95
• Exploded View, Parts List	96
• Cassette Mechanism	97~99

Speaker Section (Pages 100 ~ Pages 101)

• Schematic Diagram	100
• Exploded View, Parts List	100
• Network Ass'y	101
• Wire Forming	101

Only discs with the mark at the right can be played on this system.



Dolby noise reduction manufactured under license from Dolby Laboratories Licensing corporation.
"DOLBY" and the double-D symbol  are trademarks of Dolby Laboratories Licensing Corporation.

Receiver Unit	UDRA-65
Cassette Deck Unit	UDR-65
CD Player Unit	UCD-65
Speaker System Unit	USC-65
: Top Cushion	503 1061 000
: (Master) Carton	501 1707 009
Envelope Sub Assy	GEN 2433
: Polycover	505 0178 000
: Inst. Manual (4)	511 2498 107
: Inst. Manual (4)	511 2499 106
Loop Antenna	231 0922 009
Remocon (RC-164)	399 0202 009
FM Ant. Ass'y	395 0021 000
Green Point Label	513 2159 002

ADVARSEL: USYNLIG LASERSTRÅLING VED ÅBNING, NÅR SIKKERHEDSAFBRYDERE ER UDE AF FUNKTION. UNDGA UDSÆTTELSE FOR STRÅLING.

VARO! AVATTAESSA JA SUOJALUKITUS OHITETTAESSA OLET ALTTIINA NÄKYMÄTTÖMÄLLE LASERSÄTEILYLLE. ÄLÄ KATSO SÄTEESEEN.

VARNING - OSYNLIG LASERSTRÅLNING NÅR DENNA DEL ÄR ÖPPNAD OCH SPÄRREN ÄR URKOPPLAD. BETRakta EJ STRÅLEN.

SPECIFICATIONS







- **Receiver (UDRA-65)**
 - Amplifier**
 - Practical maximum output:** 30 W + 30 W (RMS)
 - Bass adjustment:** 100 Hz \pm 8 dB
 - Treble adjustment:** 10 kHz \pm 8 dB
 - SDB (Super Dynamic Bass):** 80 Hz + 8 dB
 - Terminals:**
 - AUX:** Input jacks (input sensitivity – 150 mV/47 kohm)
 - PROCESSOR LOOP:** (input sensitivity – 150 mV/47 kohm)
 - Headphones jack:** 3.5 mm mini size
 - Mono out:** Output jacks (rated output – 2.5 V)
 - Surround out:** Output jacks
 - Tuner**
 - Receivable frequency range:** FM: 87.50 MHz ~ 108.00 MHz
AM: 522 kHz ~ 1611 kHz
 - Reception sensitivity** FM: 2 μ V/75 ohm
AM: 20 μ V/m
 - FM stereo separation:** 35 dB (1 kHz)
 - Maximum external dimensions:** 270 (W) \times 103 (H) \times 324 (D) mm (10-5/8" \times 4-1/16" \times 12-3/4")
 - Weight:** 5.3 kg
 - Power supply:** AC 230 V, 50 Hz, AC 240 V, 50 Hz (for U.K. model)
 - Power consumption:** 95 W
- **CD player (UCD-65)**
 - Wow & flutter:** Below measurable limits (\pm 0.001% W. peak)
 - Sampling frequency:** 44.1 kHz
 - Optical source:** Semiconductor
 - Maximum external dimensions:** 270 (W) \times 89 (H) \times 306 (D) mm (10-5/8" \times 3-25/32" \times 12-3/64")
 - Weight:** 2.4 kg
- **Cassette deck (UDR-65)**
 - Type:** Horizontal 4-track 2-channel auto reverse stereo cassette deck
 - Heads:** Hard permalloy recording/playback head \times 1
Hard permalloy playback head \times 1
Double gap ferrite erasing head \times 1
 - Tape speed:** 4.75 cm/s
 - Included circuit:** Dolby B and C Noise Reduction
 - Usable tapes:** Normal, chrome and metal
 - Maximum external dimensions:** 270 (W) \times 103 (H) \times 306 (D) mm (10-5/8" \times 4-1/16" \times 12-3/64")
 - Weight:** 3.6 kg
- **Speakers (USC-65)**
 - Type:** 3-way 3-speaker bass reflex type
 - Speakers used:** 13 cm woofer, 5 cm tweeter and 2.5 cm tweeter
 - Maximum tolerable input:** 60 W
 - Impedance:** 8 ohm
 - Maximum external dimensions:** 192 (W) \times 384 (H) \times 276 (D) mm (7-9/16" \times 15-1/8" \times 10-55/64")
 - Weight:** 4.9 kg per speaker
- **Remote control unit (RC-164)**
 - Type:** Infrared pulse
 - Number of buttons:** 32
 - Maximum external dimensions:** 55 (W) \times 180 (H) \times 18 (D) mm (2-11/64" \times 7-3/32" \times 45/64")
 - Weight:** 100 g (including batteries)

* Maximum dimensions include controls, jacks, and covers.

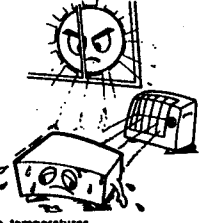
(W) = width, (H) = height, (D) = depth

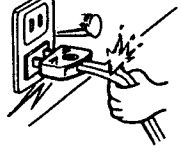
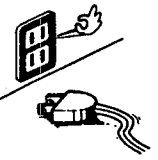
• For improvement purposes, specifications and functions are subject to change without advanced notice.

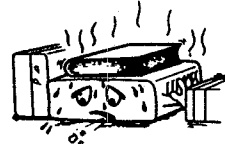
NOTE ON USE/HINWEISE ZUM GEBRAUCH/OBSERVATIONS RELATIVES A L'UTILISATION/NOTE SULL'USO

 <ul style="list-style-type: none"> • Avoid high temperatures. Allow for sufficient heat dispersion when installed on a rack. • Vermeiden Sie hohe Temperaturen. Beachten Sie, daß eine zureichende Luftzirkulation gewährleistet wird, wenn das Gerät auf ein Regal gestellt wird. • Éviter des températures élevées. Tenir compte d'une dispersion de chaleur suffisante lors de l'installation sur une étagère. • Evitate di esporre l'unità a temperature alte. Assicuratevi che ci sia un'adeguata dispersione del calore quando installate l'unità in un mobile per componenti audio. 	 <ul style="list-style-type: none"> • Keep the set free from moisture, water, and dust. • Halten Sie das Gerät von Feuchtigkeit, Wasser und Staub fern. • Protéger l'appareil contre l'humidité, l'eau et la poussière. • Tenete l'unità lontana dall'umidità, dall'acqua e dalla polvere. 	 <ul style="list-style-type: none"> • Do not let foreign objects in the set. • Keine fremden Gegenstände in das Gerät kommen lassen. • Ne pas laisser des objets étrangers dans l'appareil. • E' importante che nessun oggetto è inserito all'interno dell'unità.
 <ul style="list-style-type: none"> • Handle the power cord carefully. Hold the plug when unplugging the cord. • Gehen Sie vorsichtig mit dem Netzkabel um. Halten Sie das Kabel am Stecker, wenn Sie den Stecker herausziehen. • Manipuler le cordon d'alimentation avec précaution. Tenir la prise lors du débranchement du cordon. • Maneggiare il filo di alimentazione con cura. Agire per la spina quando scollegate il cavo dalla presa. 	 <ul style="list-style-type: none"> • Unplug the power cord when not using the set for long periods of time. • Wenn das Gerät eine längere Zeit nicht verwendet werden soll, trennen Sie das Netzkabel vom Netzstecker. • Débrancher le cordon d'alimentation lorsque l'appareil n'est pas utilisé pendant de longues périodes. • Disinnestate il filo di alimentazione quando avete l'intenzione di non usare il filo di alimentazione per un lungo periodo di tempo. 	 <ul style="list-style-type: none"> • Do not let insecticides, benzene, and thinner come in contact with the set. • Lassen Sie das Gerät nicht mit Insektiziden, Benzin oder Verdünnungsmitteln in Berührung kommen. • Ne pas mettre en contact des insecticides, du benzène et un diluant avec l'appareil. • Assicuratevi che l'unità non venga in contatto con insetticidi, benzolo o solventi.
 <p>*(For sets with ventilation holes)</p> <ul style="list-style-type: none"> • Do not obstruct the ventilation holes. • Die Belüftungsöffnungen dürfen nicht verdeckt werden. • Ne pas obstruer les trous d'aération. • Non coprite i fori di ventilazione. 	 <ul style="list-style-type: none"> • Never disassemble or modify the set in any way. • Versuchen Sie niemals das Gerät auseinander zu nehmen oder auf jegliche Art zu verändern. • Ne jamais démonter ou modifier l'appareil d'une manière ou d'une autre. • Non smontate mai, né modificate l'unità in nessun modo. 	

Irregularities

- If the system should smoke or produce strange smells, immediately set the power switch to the STANDBY position, unplug the power cord, and contact your store of purchase.

Unregelmäßigkeiten

- Sollte das Gerät Rauch produzieren oder eigenartig riechen, stellen Sie den Netzschalter sofort auf die Position STANDBY (Bereitschaft), ziehen Sie den Netzstecker heraus und kontaktieren Sie Ihren Händler.

Anomalies

- Si de la fumée sort de la chaîne ou des odeurs bizarres, placer l'interrupteur d'alimentation immédiatement sur la position de veille (STANDBY), débrancher le cordon d'alimentation et contacter le distributeur.

Irregolarità

- Qualora il sistema dovesse produrre del fumo o degli odori strani, collocate immediatamente l'interruttore di accensione nella posizione STANDBY, disinnestate il filo di alimentazione e rivolgetevi al negozio dell'acquisto.

"SERIAL NO. _____
PLEASE RECORD UNIT SERIAL NUMBER ATTACHED TO THE REAR OF THE CABINET FOR FUTURE REFERENCE"

SAFETY IMPORTANT

WARNING:
TO PREVENT FIRE OR SHOCK HAZARD, DO NOT EXPOSE THIS APPLIANCE TO RAIN OR MOISTURE.

(UDRA-65 only)

IMPORTANT (BRITISH MODEL ONLY)

The wires in this mains lead are coloured in accordance with the following code:

Blue:	Neutral
Brown:	Live

The colours of the wires in the mains lead of this apparatus may not correspond with the coloured markings identifying the terminals in your plug proceed as follows.
The wire which is coloured blue must be connected to the terminal which is marked with the letter N or coloured black.
The wire which is coloured brown must be connected to the terminal which is marked with the letter L or coloured red.

CLASS 1 LASER PRODUCT
LUOKAN 1 LASERLAITE
KLASS 1 LASERAPPARAT

ADVARSEL: USYNLIG LASERSTRÅLING VED ÅBNING. NÅR SIKKERHEDSÅFBRYDERE ER UDE AF FUNKTION. UNDGÅ UDSÆTTELSE FOR STRÅLING.

VAROITUS! LAITTEEN KÄYTTÄMINEN MUULLA KUIN TÄSSÄ KÄYTTÖOHJEESSA MAINITULLA TAVALLA SAATTAA ALTTISTAA KÄYTTÄJÄN TURVALLISUUSLUOKAN 1 YLITÄVÄLLE NÄKYMÄTTÖMÄLLE LASERSTRÄLLELLE.

VARNING: OM APPARATEN ANVÄNDS PÅ ANNAT SÄTT ÄN I DENNA BRUKSANVISNING SPECIFIKERATS, KÄN ANVÄNDAREN UTBÄTTAS FÖR OSYNLIG LASERSTRÅLNING SOM ÖVERSKRIDER GRÄNSEN FÖR LASERKLASS 1.

"CLASS 1
LASER PRODUCT"



FRONT PANEL/FRONTPLATTE/PANNEAU AVANT/PANNELLO ANTERIORE

RECEIVER
RECEIVER
AMPLI-TUNER
RICEVITORE

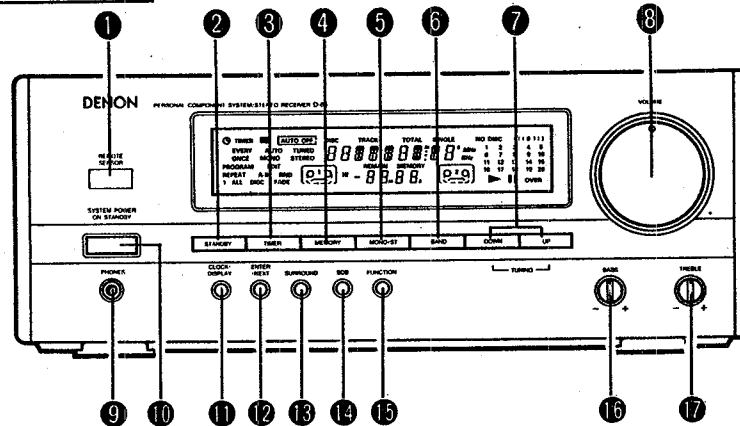

CASSETTE DECK
CASSETTENECK
PLATINE CASSETTE
PIASTRA A CASSETTE

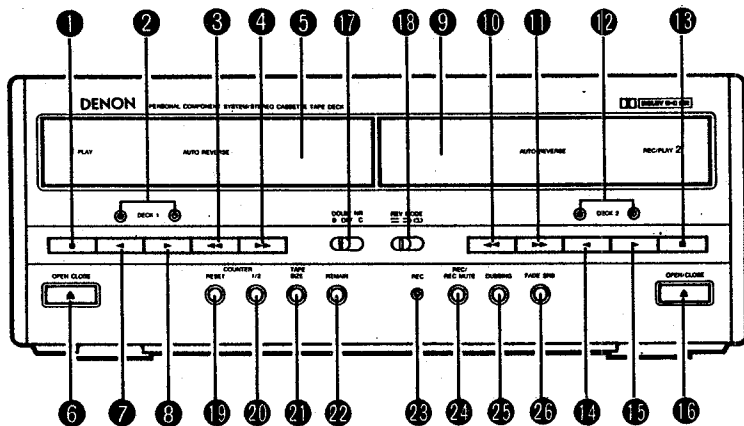

CD PLAYER
CD-SPIELER
LECTEUR CD
DISPLAY DELLA PIASTRA A CASSETTE

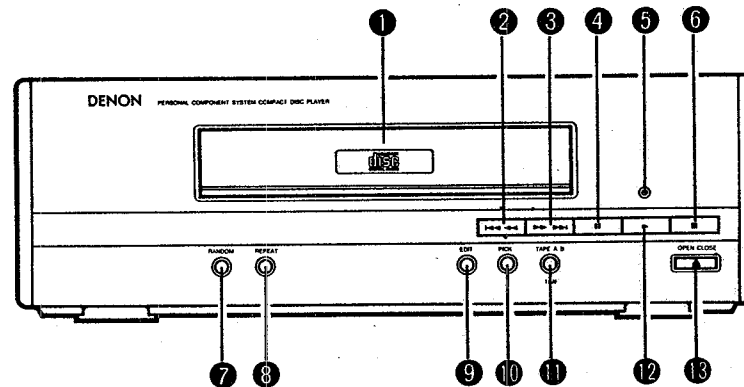

- As an aid to better understanding the operation method, the illustrations used in this manual may differ from the actual system.
- Als Hilfestellung zum besseren Verständnis der Betriebsmethode, erlauben wir uns den Hinweis, daß sich die Abbildungen in dieser Bedienungsanleitung leicht von dem aktuellen System unterscheiden.
- Pour faciliter la compréhension de la méthode de fonctionnement, les illustrations utilisées dans ce manuel peuvent être différentes de celles de la chaîne réelle.
- Per rendere la spiegazione del metodo operativo più facile, le illustrazioni usate in questo libretto delle istruzioni possono differire dal sistema stesso.

CONTENTS

1	Main Features	4	• Using the MS Function and the Music Search Display	18	
2	Before Using	4	10	Recording Cassette Tapes	19, 20
3	Antenna Connections	4	11	Playing CDs	21~25
4	Connections	5	• Compact Discs	21	
5	Part Names and Functions		• Regular Playback	21	
• Receiver	6	• Various CD Play Functions	22~24		
• Cassette Deck	7, 8	• Edited Recording onto Sides A and B of a Tape	24, 25		
• CD Player	9	12	Remote Control Unit	26	
6	Listening to Radio Broadcasts	10	13	Auto On Function	27
7	Using the Timer	11~16	14	Important Information	27
8	Cassette Deck		15	Specifications	27
• Before Recording and Playback	17	16	Troubleshooting	28	
9	Playing Cassette Tapes				
• Single Side Playback, Two-Side Playback and Continuous Playback	18				

Check that the following parts are included in the package aside from the main unit:

①	Operating Instructions	1
②	FM Antenna	1
③	AM Loop Antenna	1
④	Remote Controller (RC-164)	1
⑤	R6P/AA Batteries	2

1 MAIN FEATURES

- **Quality power designed for high sound quality**
30W + 30W high quality power amplifier.
- **Multi-function CD player with a full set of functions**
Editing function for automatically dividing the tracks on CDs for recording onto sides A and B of a tape.
Pick function for edited recording keeping the blank section at the end of the tape as short as possible.
- **Dolby B and C Noise Reduction**
Playback and recording with high sound quality.

- **Three-course timer**
Three timer settings are possible: Everyday, Sleep and Once.
- **Surround circuit**
Sound with a strong sense of presence.
- **Three-way speakers**
13cm woofer, 5cm tweeter and 2.5cm tweeter (anti-magnetic type) designed for high sound quality.

2 BEFORE USING

- Note the following points before using the D-65.**
- **Moving the system**
To prevent short-circuiting or damage of the connection cords, be sure to unplug the power cord and disconnect all connection cords before moving the system. In addition, always remove CDs before moving the system. Failing to do so may result in scratched CDs.
 - **Before switching on the power**
Check again that all connections are proper and that the connection cords are not damaged. Be sure to disconnect the power plug before disconnecting or connecting the connection cords.

- Hum may be produced if a TV set or another audio component is set near this system or their connection cords are nearby. If this happens, try changing the position of the equipment and connection cords.
- Do not move the system abruptly from a cold place to a warm place, since this may cause water droplets (condensation) to form in the equipment, preventing proper operation. If this happens, wait one hour before using the system.

3 ANTENNA CONNECTIONS

Connecting the Included Antennas

AM Loop Antenna

Assemble the included AM loop antenna as shown in the diagram, separate it as far from the system as possible, and place it in a position that provides the best reception. In some cases, reception is better if the polarities of the connections are reversed. AM broadcasts will not be received well if the loop antenna is not connected or if it is connected but is located near a metal part. Attach the loop antenna even when using an outdoor AM antenna.

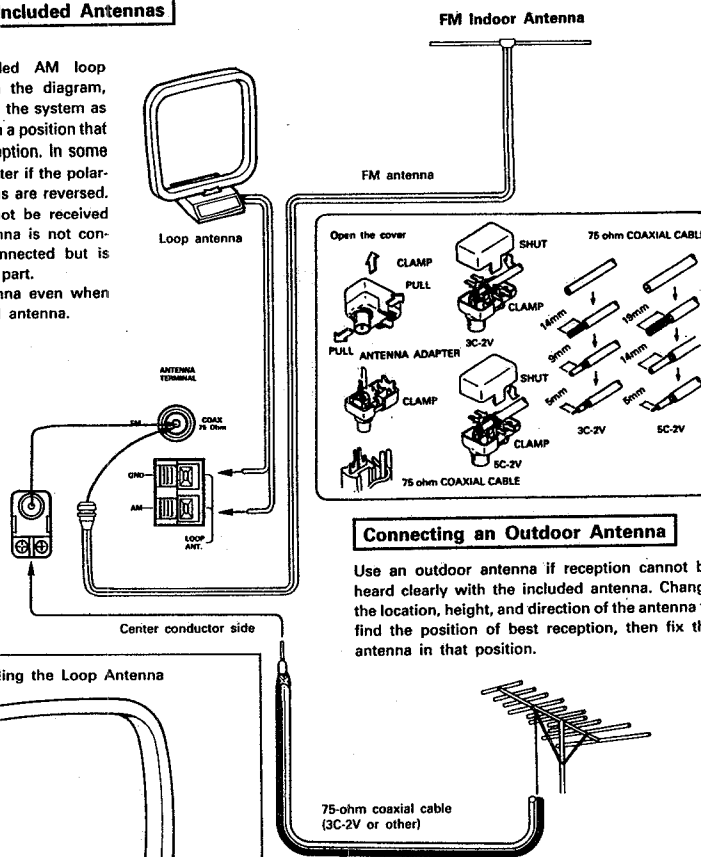

Connecting an Outdoor Antenna

Use an outdoor antenna if reception cannot be heard clearly with the included antenna. Change the location, height, and direction of the antenna to find the position of best reception, then fix the antenna in that position.

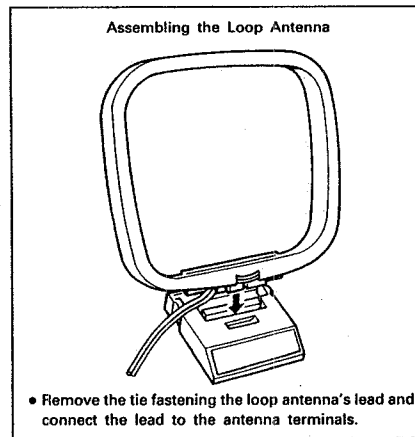

- Separate the FM and AM antenna wires from the system connector wires.

- Connect the outdoor antenna using 75-ohm coaxial cable. This will help shield the antenna from external noise.

Places for Installing Outdoor Antennas

- Install the outdoor antenna facing a broadcast station's transmission antenna. When surrounded by buildings or hills, place the antenna in the location which provides best reception and try changing the direction of the antenna to obtain optimum reception.
- Do not install the antenna under power lines. It is extremely dangerous for the antenna to come into contact with a power line.
- Install away from roads and train tracks to prevent noise from cars and trains.
- Do not install the antenna too high, as it may be hit by lightning.

4 CONNECTIONS

Processor loop jacks

Connect these to the LINE input/output jacks on the DSE-65. Connect the D-65 input jack to the DSE-65 output jack, the UDRA-65 output jack to the DSE-65 input jack.

For the surround speakers, use speakers with an impedance of 8 ohms or greater.

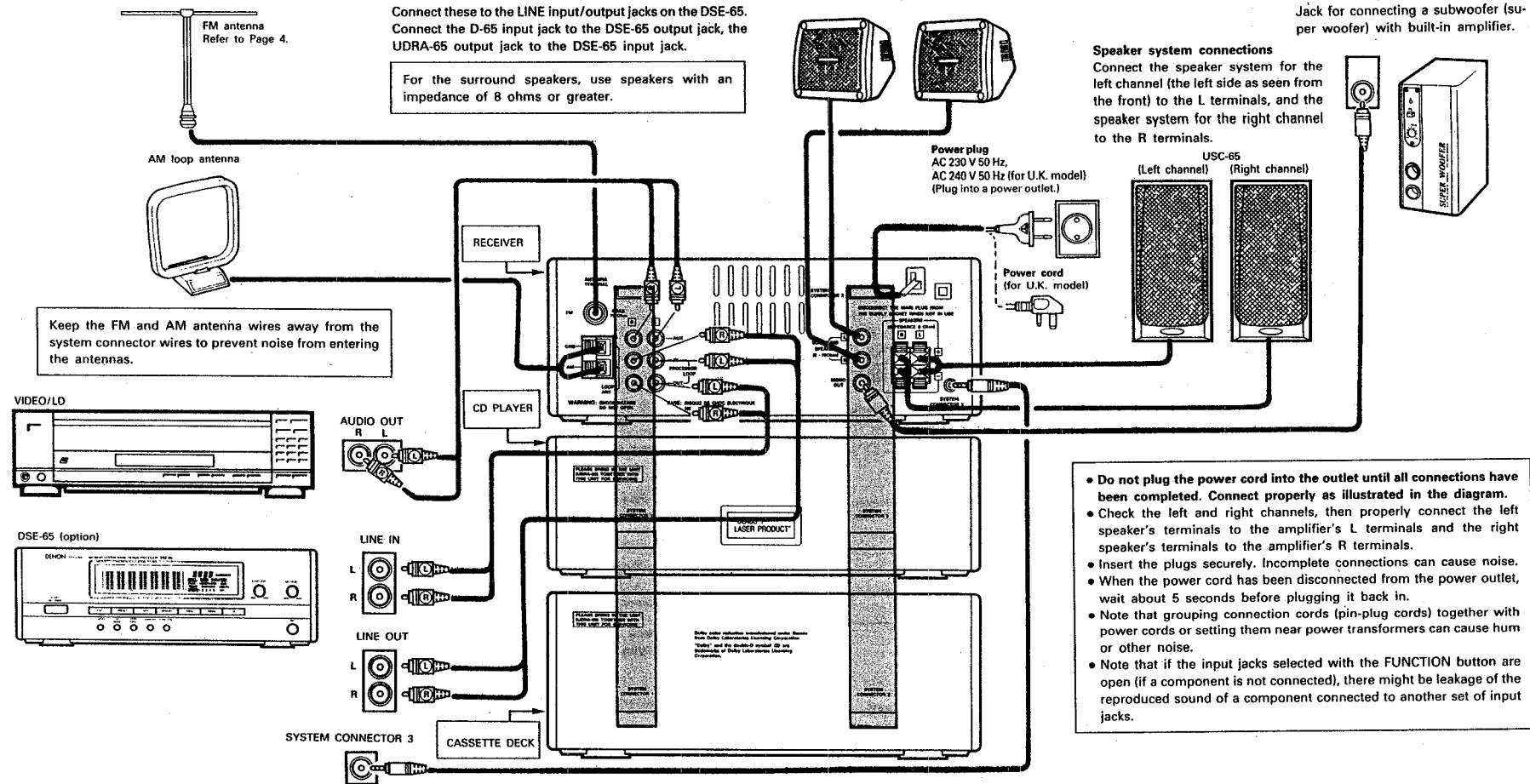

Keep the FM and AM antenna wires away from the system connector wires to prevent noise from entering the antennas.

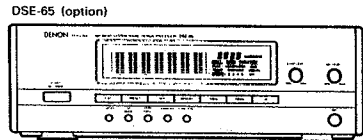
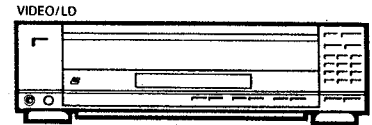

Connecting the system connector cord

When connecting the system connector cord, insert the center of the connector plug and press until a click is heard.

To disconnect the system connector cord, press the sides of the connector plug inward then pull out.



Note that pulling on the connector cord section will damage the system cord.

NOTE:

This system includes digital circuitry which may interfere with the colors on a TV. Should this occur, place this unit as far away from the TV as possible.

- Do not plug the power cord into the outlet until all connections have been completed. Connect properly as illustrated in the diagram.
- Check the left and right channels, then properly connect the left speaker's terminals to the amplifier's L terminals and the right speaker's terminals to the amplifier's R terminals.
- Insert the plugs securely. Incomplete connections can cause noise.
- When the power cord has been disconnected from the power outlet, wait about 5 seconds before plugging it back in.
- Note that grouping connection cords (pin-plug cords) together with power cords or setting them near power transformers can cause hum or other noise.
- Note that if the input jacks selected with the FUNCTION button are open (if a component is not connected), there might be leakage of the reproduced sound of a component connected to another set of input jacks.

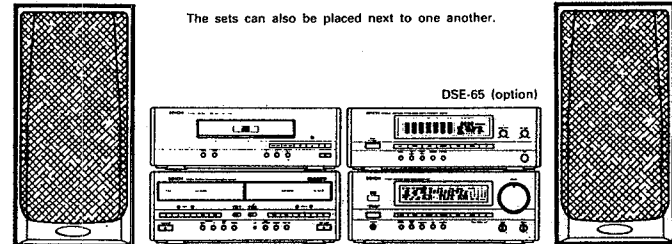

The sets can also be placed next to one another.

DSE-65 (option)

5 PART NAMES AND FUNCTIONS

RECEIVER

- 1 **REMOTE SENSOR**
Point the remote control unit at this sensor when operating it.
- 2 **STANDBY button**
Press this to activate the timer at the set times. When the timer is set and this button is pressed, the standby mark, "Ⓜ", appears on the display. When pressed again, the standby mark turns off. The timer will not function when the standby mark is turned off.
- 3 **TIMER setting button**
Use this when setting the timer.
- 4 **MEMORY button**
Use this to preset AM and FM stations.
- 5 **MONO/ST (stereo mute/mono selector) button**
Stereo Set this mode to receive broadcasts in stereo. ("AUTO" is displayed.)
(mute): The muting circuit is activated and the noise between stations is cut. (At the FM setting.)
Mono: Set this mode to receive in monaural, whether the broadcasts are in stereo or monaural.
Set this mode when there is much noise in the stereo mute mode ("AUTO" displayed) or when the signals are weak.
- 6 **BAND (AM/FM selector) button**
Press this to switch the band between AM and FM.
- 7 **TUNING UP and DOWN buttons**
Use these to tune in AM and FM stations and when setting the time and timer.
- 8 **VOLUME control**
Use this to adjust the overall volume.
Turn the control clockwise (↻) to increase the volume, counterclockwise (↺) to decrease the volume.
- 9 **PHONES jack**
Plug in the headphones here.
No sound is produced from the speakers when the headphones are plugged in.
- 10 **SYSTEM POWER button**
When this button is pressed, the power of the entire system is turned on, and the set is set to the standby mode.
- 11 **CLOCK/DISPLAY selector button**
Use this to switch the display between the frequency or function display and the clock display.
- 12 **ENTER/NEXT setting button**
Use this to move on to the next operation when setting the timer or the current time.
- 13 **SURROUND button**
Separately sold surround speakers can be connected to enjoy surround sound.
- 14 **SDB (Super Dynamic Bass) button**
Press this button for a more powerful bass sound.
- 15 **FUNCTION (input function selector) button**
Use this to switch the input.
The input switches in the following order: TUNER→TAPE→CD→AUX.
- 16 **BASS control**
Use this to adjust the bass sound.
- 17 **TREBLE control**
Use this to adjust the treble sound.

RECEIVER DISPLAY

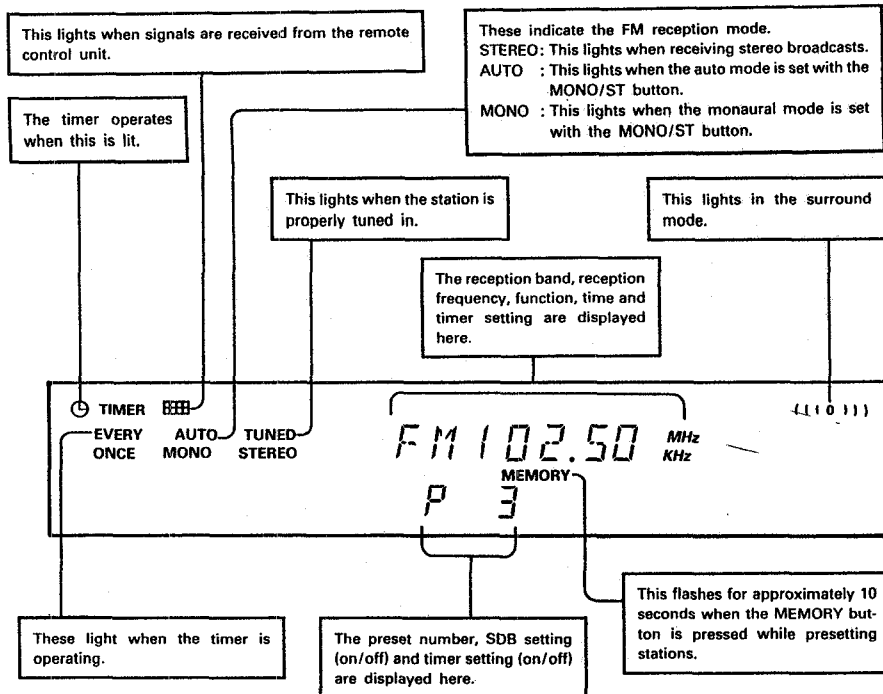

NOTE:

The standby mark, "Ⓜ", is not displayed when the current time or timer is not set.

SURROUND button

- Press this button to enjoy music with the power and presence of a theater or sound like that of a concert hall.
- Connect separately sold surround speakers and press the SURROUND button for an even more powerful sound.
- The surround speakers can be set in any position according to the conditions in the room, but it is common to set them as shown below according to the software being used. The surround speakers can also be installed in the ceiling, pointed toward the walls, etc. Set them to suit your own preferences.

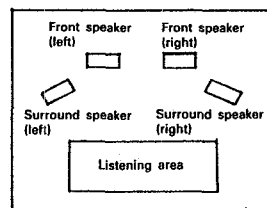

Use this set-up mainly for classical music with the atmosphere of a concert hall.

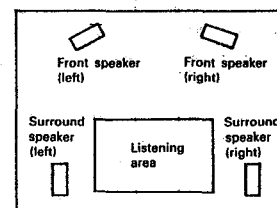

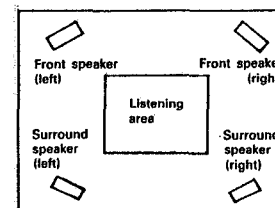

Use this set-up mainly for pop, rock or disco music.



Use this set-up mainly for enjoying movies with the atmosphere of a movie theater.

CASSETTE DECK

- 1 **(stop) button: DECK 1**
Press this button when the tape is moving to stop the tape.
- 2 **Direction of tape travel LEDs: DECK 1**
These indicate the direction in which the tape is moving and whether or not a tape is loaded. The indicators flash when the tape is being fast-forwarded and rewound. When a tape is moving, the direction of tape travel LEDs for the opposite deck are off.
- 3 **◀ (rewind) button: DECK 1**
Press this to rewind the tape.
Also, press this button during playback in the ▶ (forward) direction to move back to the beginning of that selection, or during playback in the ◀ (reverse) direction to move ahead to the beginning of the next selection.
- 4 **▶▶ (fast-forward) button: DECK 1**
Press this to fast-forward the tape.
Also, press this button during playback in the ▶ (forward) direction to move ahead to the beginning of the next selection, or during playback in the ◀ (reverse) direction to move back to the beginning of that selection.
- 5 **Cassette tray: DECK 1**
This opens out when the OPEN/CLOSE button is pressed. Insert the cassette tape with the side on which the tape is exposed facing away from you. To close the cassette tray, press the OPEN/CLOSE button again. When the cassette tray is left open for a time, it will be closed automatically.
- 6 **OPEN/CLOSE button: DECK 1**
Use this button to open and close the cassette tray. This button functions in the standby mode as well.
- 7 **◀ (reverse play) button: DECK 1**
Press this button to play the tape in the reverse direction.
When pressed in the standby mode, the power automatically turns on and playback starts.
- 8 **▶ (forward play) button: DECK 1**
Press this button to play the tape in the forward direction.
When pressed in the standby mode, the power automatically turns on and playback starts.
- 9 **Cassette tray: DECK 2**
This opens out when the OPEN/CLOSE button is pressed. Insert the cassette tape with the side on which the tape is exposed facing away from you. To close the cassette tray, press the OPEN/CLOSE button again. When the cassette tray is left open for a time, it will be closed automatically.
- 10 **◀◀ (rewind) button: DECK 2**
Press this to rewind the tape.
Also, press this button during playback in the ▶ (forward) direction to move back to the beginning of that selection, or during playback in the ◀ (reverse) direction to move ahead to the beginning of the next selection.
- 11 **▶▶▶ (fast-forward) button: DECK 2**
Press this to fast-forward the tape.
Also, press this button during playback in the ▶ (forward) direction to move ahead to the beginning of the next selection, or during playback in the ◀ (reverse) direction to move back to the beginning of that selection.
- 12 **Direction of tape travel LEDs: DECK 2**
These indicate the direction in which the tape is moving and whether or not a tape is loaded. The indicators flash when the tape is being fast-forwarded and rewound. When a tape is moving, the direction of tape travel LEDs for the opposite deck are off.
- 13 **(stop) button: DECK 2**
Press this button when the tape is moving to stop the tape.
- 14 **◀ (reverse play) button: DECK 2**
Press this button to play the tape in the reverse direction.
When pressed in the standby mode, the power automatically turns on and playback starts.
- 15 **▶ (forward play) button: DECK 2**
Press this button to play the tape in the forward direction.
When pressed in the standby mode, the power automatically turns on and playback starts.
- 16 **OPEN/CLOSE button: DECK 2**
Use this button to open and close the cassette tray. The button functions in the standby mode as well.
- 17 **DOLBY NR switch**
Use this to select the Dolby NR mode, "OFF", "B" type or "C" type.
When playing tapes, set this switch to the same position as when the tape was recorded.
- 18 **REV MODE switch**
Use this to select the reverse mode,  (one-side mode),  (two-side mode), or  (continuous mode).
For details, refer to page 17.
- 19 **COUNTER RESET button**
Press this to reset the tape counter to "0000".
- 20 **COUNTER 1/2 button**
Use this to switch the counter display between Deck 1 or Deck 2.
- 21 **TAPE SIZE setting button**
Use this to set the tape time according to the length of the tape being used.
For details, refer to page 8.
- 22 **REMAIN button**
Press this to switch the tape counter to the remaining time display.
- 23 **REC LED**
This lights when in the recording and recording standby modes, and flashes in the recording mute mode.
- 24 **REC/REC MUTE button**
To record, press the REC/REC MUTE button and play button. The recording pause mode is set if only the REC/REC MUTE button is pressed. If pressed again, the recording mute mode is set for approximately 5 seconds (a blank section is recorded on the tape), after which the recording pause mode is set.
If the REC/REC MUTE button is pressed for less than 0.5 seconds during recording, the recording pause mode is set. Depressing this button for 0.5 seconds or longer will set the recording mute mode for approximately 5 seconds, after which the recording pause mode is set.

Recording pause mode:

Press the CD player's play button during the recording pause mode to start recording the CD.

- 25 **DUBBING button**
Simply press this button to copy from Deck 1 onto Deck 2.
- 26 **FADE SRS button**
Use this button for synchronized recording of CDs. The fade-out function is activated if the end of the tape is reached in the middle of a selection.
For details, refer to page 20.

• Deck 1 is for playback only, Deck 2 for both recording and playback.

CASSETTE DECK DISPLAY

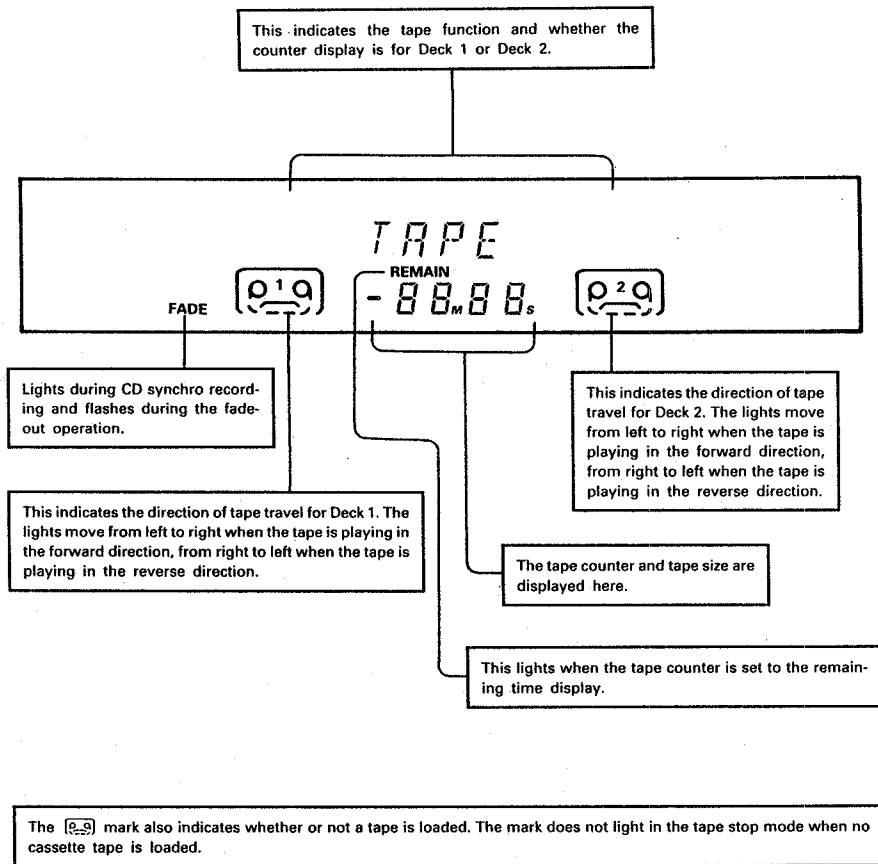

USING THE TAPE COUNTER

1. Tape Counter Display

(1) Linear Counter

- The tape counter indicates the elapsed time of the running tape in minutes and seconds.

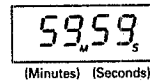

- The counter is reset to "00:00" when the tape is ejected and loaded, and by the COUNTER RESET button.
- Making a memo of the contents of a recording and the range of the counter numbers while you are recording or playing back a tape will be convenient when you search for a portion of the tape you would like to listen to or when you search for the next portion you would like to record.

(2) Remaining Time Counter (REMAIN)

- This display indicates the remaining time of the tape being used.

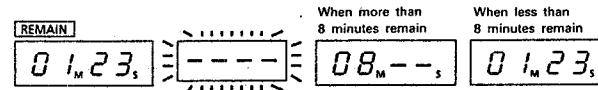

- Run the tape and in about 10 seconds hyphens will flash to indicate that the remaining time is being computed. After this, if the display time is 8 minutes or longer, only the minutes digits will be displayed; if the display time is less than 8 minutes, the minutes and seconds digits will be displayed.
- The display will change to hyphens during fast forward or rewind.

2. Tape Size Selector

- Match the tape size with the tape being used.
- Press the TAPE SIZE button until the desired tape size is displayed, then press the button again while the tape size is being displayed to set it. With each press of the button, the display will change according to the following cycle.

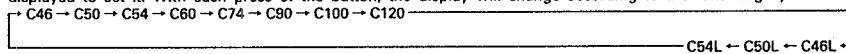

- *C46L, C50L, and C54L indicate large-hubbed cassettes.
- *Only values included in the display can be set.

3. END Display

This display indicates that the tape is reaching the end during recording or playback.

- Match the tape size with the tape you are going to use.
- The (0 9) mark for strats flashing approximately 5 minutes before the end of the tape. (END DISPLAY) (This only works properly when the tape size setting matches the length of the tape being used. If they do not match, there may be a major error in the time when the mark begins flashing.)
- When the tape has been recorded or played back to its end, the flashing of the END indicator will change to steady lighting.
- *Note that this indicator is only a guide and its operation will vary according to the size of the hub diameter of the tape as well as with differences of tape thickness, so that the END indicator might not light in some cases.

NOTE:

This deck's linear tape counter has been set for the following cassette tape lengths: C46, C50, C54, C60, C74, C90, C100, C120, C46L, C50L, and C54L. (L indicates large-hubbed cassettes.)

Using a tape that lies outside of this range, or a tape with a different length than the displayed lengths, will result in error. When using a tape that is not included in the TAPE SIZE selection, select the tape size closest to the length of the tape to be used. (This will reduce the error.)

The linear tape counter is not accurate like a clock. The thickness of the tape will differ depending on the type of tape used (tape position and time), and so there will be some error introduced. Error also arises from the difference between tapes with smaller and larger hubs.

- Large hubs are ones with a diameter of about 27 mm. Note that if the hub is larger than this, there will be a large error in indicating the tape travel time.

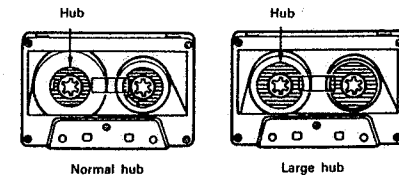

Dolby noise reduction manufactured under license from Dolby Laboratories Licensing Corporation. "DOLBY" and the double-D symbol are trademarks of Dolby Laboratories Licensing Corporation.

CD PLAYER

- 1 **Disc tray**
Load the compact disc here. When the disc tray is left open for a time, it will be closed automatically.
- 2 **⏮ (automatic/manual search reverse) button**
Use this button to search for the beginning of a specific track. Press it during the play, stop, or pause mode a number of times equal to the number of tracks to be skipped in the reverse direction.
- 3 **⏭ (automatic/manual search forward) button**
Use this button to search for the beginning of a specific track. Press it during the play, stop, or pause mode a number of times equal to the number of tracks to be skipped in the forward direction.
* The search mode is set if buttons 2 and 3 are released within 0.5 seconds after being pressed, and the manual fast-reverse or fast-forward mode is set if the buttons are held in for more than 0.5 seconds.
* During the pause mode, buttons 2 and 3 function as the automatic search forward button and the automatic search reverse button, respectively.
- 4 **⏸ (pause) button**
Press this to stop playback temporarily.
Press the play button to resume playback.
- 5 **Disc play LED**
This lights when a disc is playing, and flashes in the pause mode.
- 6 **■ (stop) button**
Press this to stop playback.
- 7 **RANDOM button**
Press this to play the tracks on the disc in random order.
- 8 **REPEAT button**
Press this to set the repeat play mode.

- 9 **EDIT button**
Press this for edited recording onto a tape, automatically dividing the tracks to be recorded on sides A and B according to the length of the tape.
- 10 **PICK button**
Press this for edited recording onto a tape, keeping the empty space at the end of the tape to a minimum length.
- 11 **TAPE A/B (edit display selector)/TIME (time display selector) button**
Press this button during editing to switch the display between the program for sides A and B of the tape. Also, press this button during the play or pause modes to change the time display.
* When pressed during the play or pause modes, the time display switches between the elapsed playing time for the currently playing track, the remaining time for that track ("SINGLE" lights), and the total remaining time ("TOTAL" lights). During programmed playback, the time displayed when the "TOTAL" indicator is lit is the total remaining time for the programmed tracks.
- 12 **▶ (play) button**
Press this to start playing the disc. If pressed when the disc tray is open, the disc tray closes and playback begins. When pressed during the standby mode, the power automatically turns on and playback begins.
- 13 **OPEN/CLOSE button**
Use this to open and close the disc tray.
When pressed once, the disc tray opens out, and when pressed again the disc tray closes. This button functions even in the standby mode.

CD PLAYER DISPLAY

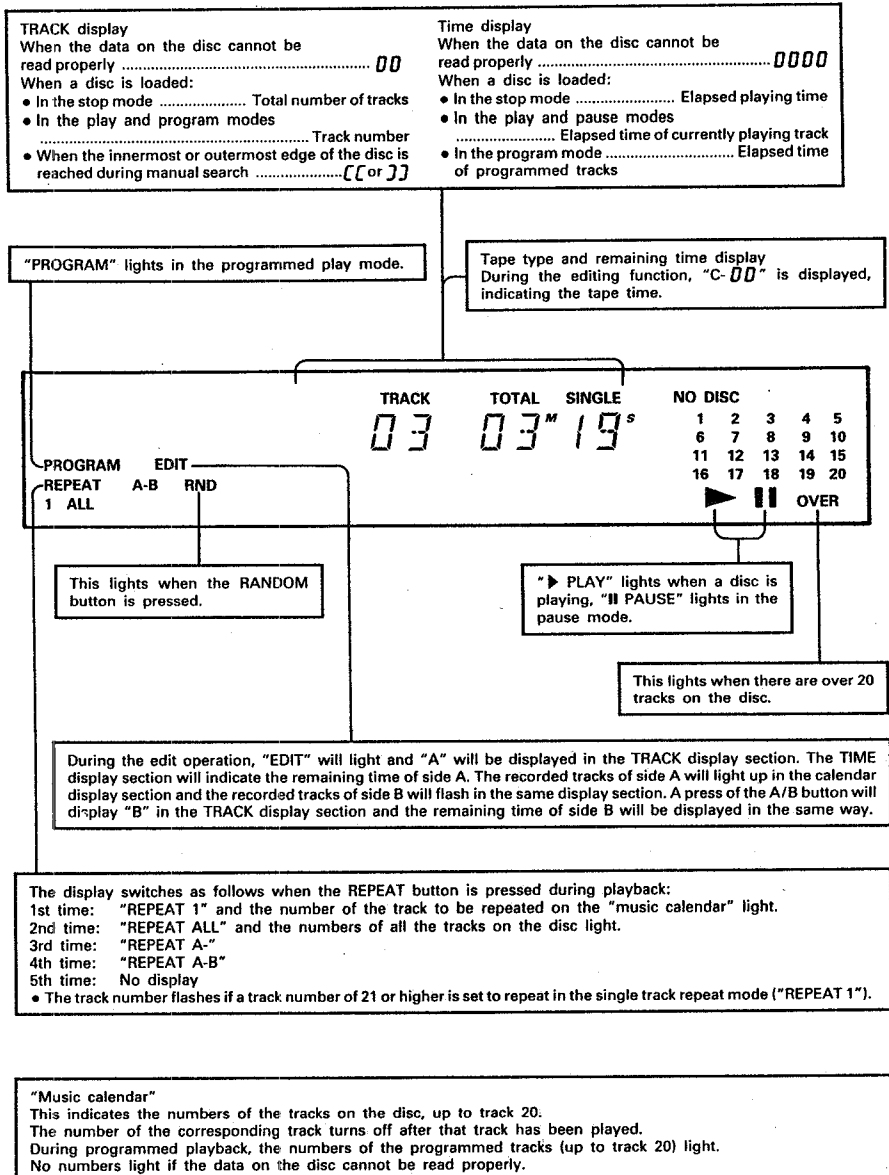

- "NO DISC" lights if no disc is loaded, if the disc is loaded upside-down, or if the disc is heavily scratched or dirty.

6 LISTENING TO RADIO BROADCASTS

(Check that connections are proper, referring to Page 5)

TUNING

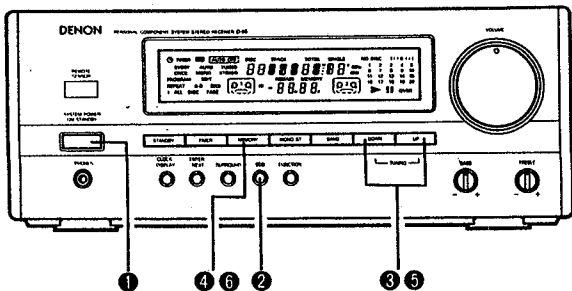

Example: Tuning to 87.50 MHz, FM

1	Set the VOLUME control to the minimum position, then press the SYSTEM POWER button.		
2	Select the FM band with the BAND button.		Set to FM. FM 90.50 MHz
3	Use the UP and DOWN buttons to set the frequency to 87.50 MHz. Once a station has been tuned in, use the VOLUME control to adjust the volume to the desired level.		Lights up when the station is tuned in. TUNED FM 87.50 MHz

Presetting AM and FM Stations

Example: Presetting the (currently tuned) FM 87.50 MHz to preset number 3

4	Press the MEMORY button. [MEMORY] flashes for 10 seconds.		TUNED FM 87.50 MHz Flashes
5	Use the UP and DOWN buttons to call up the number to which you want to preset the station. Or, directly press the number buttons on the remote control unit. The preset number will flash.		TUNED FM 87.50 MHz Flashes P Flashes
6	Press the MEMORY button while [MEMORY] is flashing.		TUNED FM 87.50 MHz P3 is lit

Up to 30 AM and FM stations can be preset at random using this procedure.

Auto Tuning

- When the TUNING buttons are pressed, the frequency changes in steps of 50 kHz for FM, 9 kHz for AM.
- If the TUNING UP or DOWN button is held in for more than 1 second, the frequency continues to change when the button is released. The next station is tuned in automatically and the tuning stops there. Note that tuning will not stop if the antenna input is weak and the [TUNED] indicator does not light. To stop the auto tuning, press the UP or DOWN button again.

Listening to Preset Stations

Example: Listening to the FM station preset at number 3

1	Press the TUNER button on the remote control unit.		TUNED FM 87.50 MHz P 3
2	Press button "3" on the remote control unit.		

Notes on Presetting

- When an FM station is preset, the auto or monaural mode is also set, so check the display before presetting the station.
- If a station is preset to a number at which another station has previously been preset, the previous station is cleared and the new station is preset.
- You can prevent the erasure of the preset memories by disconnecting the power cord for only a short while, but after 24 hours the presets will be erased, in which case they should be set again.

7 USING THE TIMER

Setting the Timer

- Be sure to set the current time.
 - Everyday timer: This turns the power on and off once at the same time every day.
 - Once timer: This turns the power on and off once only.
 - Sleep timer: The number of minutes after which the power is to turn off, up to 60 minutes in steps of 10 minutes, is set from the remote control unit.
- Be sure to preset the station before setting the timer.
For instructions, refer to "Presetting AM and FM Stations" on page 10.
- When the timer is not being used, press the STANDBY button and delete the standby mark "⊕".

Power Failure

Should a power failure occur or if the power cord becomes unplugged from the power outlet, "00:00" or the time at which the power failed will flash on the time display. If this happens, reset the current time.
(Reset the current time and timer settings. If "00:00" was displayed, also reset the stations preset on the tuner.)
The standby mark starts flashing if there is a power failure or the power cord is unplugged while the standby mark is lit. If this happens, reset the time and the timer. (If the display reads 00:00, also reset the tuner's preset channels.)
To make the standby mark stop flashing, reset the current time.

Setting the Current Time (A 24-hour clock display is used.)

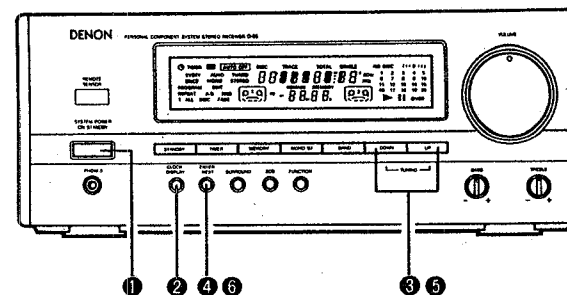

Example: Setting to 19:30 (7:30 p.m.)

1	Press the SYSTEM POWER button.		
2	Hold in the CLOCK/DISPLAY button for 3 seconds or longer.		00:00 The hour's place flashes. (All places flash if the time has already been set.)
3	Set the hours with the UP and DOWN buttons.		19:00 The set places flash.
4	Press the ENTER/NEXT button.		19:00 The minutes' places flash.
5	Set the minutes with the UP and DOWN buttons.		19:30 The set places flash.
6	Press the ENTER/NEXT button at the sound of a time signal. The time display lights steadily and the clock starts keeping the time.		19:30 The display lights steadily and the clock starts to count from 0 seconds.

Setting the Every Day Timer

(Preset the AM and FM stations in advance)

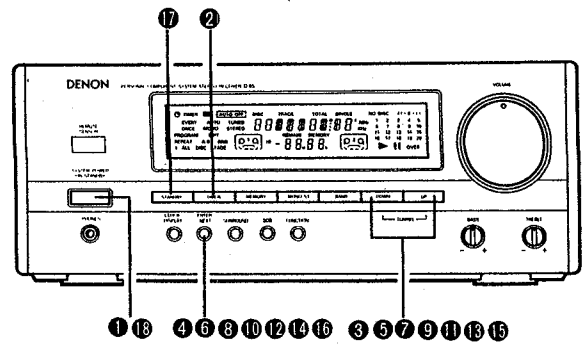

Example: Setting the timer to turn on at 12:35 and off at 12:56.
 90.00 MHz FM is being received on preset number "1".
 87.50 MHz FM is set to preset number "3".

1	Press the SYSTEM POWER button.		
2	Press the TIMER button.		
3	Press the UP button to display "EVERY".		
4	Press the ENTER/NEXT button.		
5	Press the UP and DOWN buttons to display "TUNER".		
6	Press the ENTER/NEXT button.		
7	Press the UP and DOWN buttons to set the preset number.		
8	Press the ENTER/NEXT button.		
9	Use the UP and DOWN buttons to set the hour at which the timer is to switch on.		
10	Press the ENTER/NEXT button.		

11	Use the UP and DOWN buttons to set the minutes at which the timer is to switch on.		
12	Press the ENTER/NEXT button.		
13	Use the UP and DOWN buttons to set the hour at which the timer is to switch off.		
14	Press the ENTER/NEXT button.		
15	Use the UP and DOWN buttons to set the minutes at which the timer is to switch off.		
16	Press the ENTER/NEXT button.		
17	Press the STANDBY button.		
18	Press the SYSTEM POWER button.		

- When the STANDBY button is pressed and the "☉" mark is lit, the timer will function at the same times each day.
- To switch off the timer, press the STANDBY button and turn off the "☉" mark.

NOTE:
 The standby mark "☉" will not light unless the current timer has been set. Should this be the case, set the current time, then press the STANDBY button.

Setting the Once Timer

(Preset the AM and FM stations in advance)

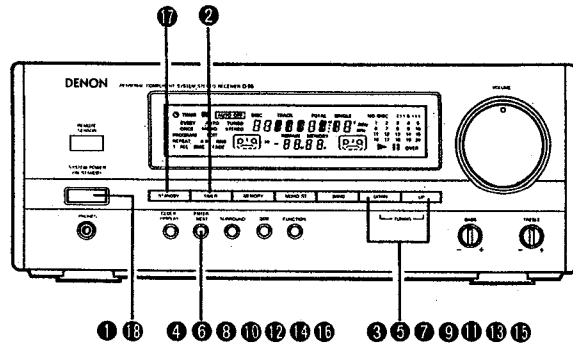

Example: Setting the timer to turn on at 12:35 and off at 12:56.
522 kHz AM is being received on preset number "2".
1611 kHz AM is set to preset number "15".

1	Press the SYSTEM POWER button.		
2	Press the TIMER button.		
3	Press the DOWN button to display "ONCE".		
4	Press the ENTER/NEXT button.		
5	Press the UP and DOWN buttons to display "TUNER".		
6	Press the ENTER/NEXT button.		
7	Press the UP and DOWN buttons to set the preset number.		
8	Press the ENTER/NEXT button.		
9	Use the UP and DOWN buttons to set the hour at which the timer is to switch on.		
10	Press the ENTER/NEXT button.		

11	Use the UP and DOWN buttons to set the minutes at which the timer is to switch on.		
12	Press the ENTER/NEXT button.		
13	Use the UP and DOWN buttons to set the hour at which the timer is to switch off.		
14	Press the ENTER/NEXT button.		
15	Use the UP and DOWN buttons to set the minutes at which the timer is to switch off.		
16	Press the ENTER/NEXT button.		
17	Press the STANDBY button.		
18	Press the SYSTEM POWER button.		

- When the STANDBY button is pressed and the "Ⓢ" mark is lit, the timer will function one time only.
- To switch off the timer, press the STANDBY button and turn off the "Ⓢ" mark.

NOTE:
The standby mark "Ⓢ" will not light unless the current timer has been set. Should this be the case, set the current time, then press the STANDBY button.

Ways to Use the Timer

Example 1: Waking up to the music of a compact disc.

1 EVERYDAY TIMER

1	<p>Press the receiver's SYSTEM POWER button to switch on the power. → Press the CD player's OPEN/CLOSE button to open the tray. → Set the compact disc in the tray. → Press the OPEN/CLOSE button again to close the tray.</p>
2	<p>Press the receiver's TIMER button.</p> <p>Flashes TIMER EVERY ONCE TIMER</p>
3	<p>Press the UP button to display "EVERY".</p> <p>Flashes TIMER EVERY TIMER</p>
4	<p>Press the ENTER/NEXT button.</p> <p>TIMER EVERY FUNC</p>
5	<p>Press the UP and DOWN buttons of the receiver to display "CD".</p> <p>TIMER EVERY CD</p>
6	<p>Follow steps 8 to 18 under "Setting the Timer" on Page 12.</p>

2 ONCE TIMER

1	<p>Press the receiver's SYSTEM POWER button to switch on the power. → Press the CD player's OPEN/CLOSE button to open the tray. → Set the compact disc in the tray. → Press the OPEN/CLOSE button again to close the tray.</p>
2	<p>Press the receiver's TIMER button.</p> <p>Flashes TIMER EVERY ONCE TIMER</p>
3	<p>Press the DOWN button to display "ONCE".</p> <p>Flashes TIMER ONCE TIMER</p>
4	<p>Press the ENTER/NEXT button.</p> <p>TIMER ONCE FUNC</p>
5	<p>Press the UP and DOWN buttons of the receiver to display "CD".</p> <p>TIMER ONCE CD</p>
6	<p>Follow steps 8 to 18 under "Setting the Timer" on Page 13.</p>

Example 2: Waking up to the music of a cassette tape.

1 EVERYDAY TIMER

1	<p>Press the receiver's SYSTEM POWER button to switch on the power. → Press the cassette deck's OPEN/CLOSE button to open the tray. → Load the cassette tape. → Press the OPEN/CLOSE button again to close the tray.</p>
2	<p>Press the receiver's TIMER button.</p> <p>Flashes TIMER EVERY ONCE TIMER</p>
3	<p>Press the UP button to display "EVERY".</p> <p>Flashes TIMER EVERY TIMER</p>
4	<p>Press the ENTER/NEXT button.</p> <p>TIMER EVERY FUNC</p>
5	<p>Press the UP and DOWN buttons of the receiver to display "TAPE".</p> <p>TIMER EVERY TAPE</p>
6	<p>Follow steps 8 to 18 under "Setting the Timer" on Page 12.</p>

2 ONCE TIMER

1	<p>Press the receiver's SYSTEM POWER button to switch on the power. → Press the cassette deck's OPEN/CLOSE button to open the tray. → Load the cassette tape. → Press the OPEN/CLOSE button again to close the tray.</p>
2	<p>Press the receiver's TIMER button.</p> <p>Flashes TIMER EVERY ONCE TIMER</p>
3	<p>Press the DOWN button to display "ONCE".</p> <p>Flashes TIMER ONCE TIMER</p>
4	<p>Press the ENTER/NEXT button.</p> <p>TIMER ONCE FUNC</p>
5	<p>Press the UP and DOWN buttons of the receiver to display "TAPE".</p> <p>TIMER ONCE TAPE</p>
6	<p>Follow steps 8 to 18 under "Setting the Timer" on Page 13.</p>

Example 3: Unattended recording of radio broadcasts ("air checks")

1 EVERYDAY TIMER

1	<p>Press the receiver's SYSTEM POWER button to switch on the power. → Press the deck 2 OPEN/CLOSE button to open the tray. → Load the cassette tape to which you will record. → Press the OPEN/CLOSE button again to close the tray.</p>
2	<p>Press the receiver's TIMER button.</p>
3	<p>Press the UP button to display "EVERY".</p>
4	<p>Press the ENTER/NEXT button.</p>
5	<p>Press the UP and DOWN buttons of the receiver to display "AIR.CH".</p>
6	<p>Follow steps 6 to 18 under "Setting the Timer" on Page 13.</p>

2 ONCE TIMER

1	<p>Press the receiver's SYSTEM POWER button to switch on the power. → Press the deck 2 OPEN/CLOSE button to open the tray. → Load the cassette tape to which you will record. → Press the OPEN/CLOSE button again to close the tray.</p>
2	<p>Press the receiver's TIMER button.</p>
3	<p>Press the DOWN button to display "ONCE".</p>
4	<p>Press the ENTER/NEXT button.</p>
5	<p>Press the UP and DOWN buttons of the receiver to display "AIR.CH".</p>
6	<p>Follow steps 6 to 18 under "Setting the Timer" on Page 12.</p>

- Timer recording starts in the direction indicated by the tape direction indicator of deck 2.
- Check that the tape direction and REV MODE switch settings are as desired.
- The section of leader tape at the beginning of the tape cannot be recorded. To avoid missing the beginning of the recording, set the starting time to about 1 minute before the program is scheduled to start.

Checking the Timer Settings

To check the timer settings, switch on the power of the receiver, press the TIMER button, then press the UP or DOWN button, and press the ENTER/NEXT button. The timer mode, timer start mode, reception band, preset number, on time, and off time are displayed in order each time the ENTER/NEXT button is pressed. One more press returns the display to the reception frequency.

When the on time and off time have not been set, you cannot set the timer.

Changing the Timer Settings

When the timer setting operation is repeated, the previous settings are deleted and the new settings are set.

Deleting the Timer Settings

The timer settings can be cleared by pressing the TIMER button and then the UP or DOWN button and then while "FUNC" is being displayed, pressing the TIMER button.

Note about the Set Timer

If the set time of the timer is reached while the power is on, the timer settings will take over and there will be a switch to the function that has been set on the timer.

Cancelling the Timer

Press the TIMER STANDBY button and the "Ⓢ" mark will go off.

Setting the Sleep Timer

(Use the remote control unit for these operations.)

Example: Setting the power to switch off in 50 minutes.

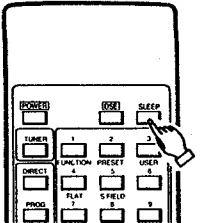
Currently receiving 87.50 MHz, FM.	FM 87.50 MHz	
<p>1</p>  <p>Press the remote control unit's SLEEP button.</p>	<p>SLEEP 5-60</p> <p>"60" is displayed.</p>	
<p>2</p> <p>Press the SLEEP button again while "SLEEP" is flashing.</p>	<p>SLEEP 5-50</p> <p>"50" is displayed.</p> <p>"SLEEP" appears and flashes for 3 seconds.</p> <p>AUTO TUNED STEREO FM 87.50 MHz 5-50</p>	<p>The power is switched off after 50 minutes.</p>

- The display returns to "S-60" (60 minutes) if the SLEEP button is pressed while the sleep timer is functioning.

Cancelling the Sleep Timer

- To cancel the timer while it is operating in the sleep mode, press the SLEEP button, and while "SLEEP" is flashing, press the CLEAR button on the tuner-preamplifier.
- Press the SLEEP button and continue to press it until the power is switched off. When the power is switched off the sleep timer will be cancelled.

- If the sleep timer and regular timer settings overlap, the sleep timer is given priority.
- Do not press the TIMER STANDBY button after the power has been switched on with the timer. If this is done, the timer will not function properly.
- If the same time is set for the on time and off time, the power will not be switched on even when the "STANDBY" indicator is lit.
- If the timer is set for an AM or FM station and the on time of the timer is reached while listening to another station, the tuner switches to the station which was set with the timer.
- If the display is not normal, unplug the power cord, then holding in the MEMORY button and the BAND button, plug the power plug into the power outlet. This will reset the tuner to the initial settings and provide a proper display. If this is done, reset the preset stations, current time, and timer settings.

Order of Priority for the Everyday, Once and Sleep Timers

- ① The sleep timer has priority for the off time. (The bold lines indicate operation.)

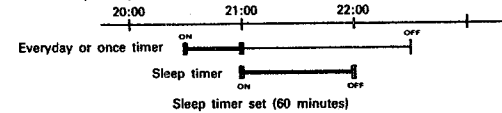

Even if the power has been turned on by the everyday or once timer, if the sleep timer time reaches "00" before the off time which was set, the power turns off. Also, the everyday or once timer does not function if the on time set for these timers is reached while the sleep timer is functioning.

- ② The once timer has priority over the everyday timer. (The bold lines indicate operation.)

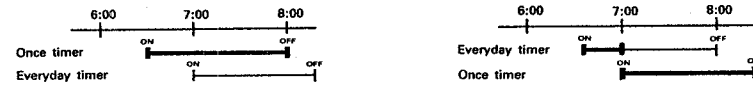

The everyday timer does not function if the on time set for it is between the on and off times set for the once timer.

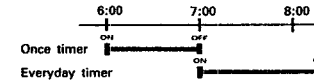

The once timer functions if its on time is set between the everyday timer's on and off times.

The everyday timer functions if the on times set for the once and everyday timers are the same.

8 CASSETTE DECK

Before Recording and Playback

Auto Reverse

This deck is equipped with an auto reverse mechanism, so cassette tapes can be played and recorded on both sides or played continuously without having to turn them over.

Direction of tape travel

This deck has two play buttons, one for the forward direction (front side) and another for the reverse direction (back side). The side being played can be changed during playback by pressing the opposite play button.

Reverse mode

Set the reverse mode switch (REV MODE) as follows:

Single-side recording/playback mode ()

In this position, only the front side or the back side of the cassette tape is played or recorded. (The tape stops automatically when the end of that side is reached.)

Two-side recording/playback mode ()

In this position, when the end of the front side is reached, recording or playback automatically switches to the back side and continues from there. (The tape stops automatically when the end of the back side is reached.)



Continuous playback mode ()

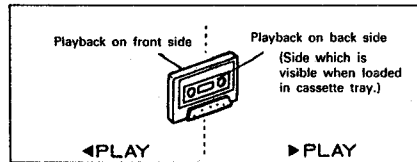

When tape is loaded in only one of the decks, playback continues until the STOP button is pressed.

Relay playback mode ()

When tapes are loaded in both decks, playback continues from deck 1 onto deck 2, and then back again, as shown in the diagram at the right.



Start from front side  →  Auto stop

Auto stop  ←  Start from back side

Start from front side  →  →  Reverse

Auto stop  ←  ←  Reverse

* If you start playing or recording from the back side, the tape will stop automatically at the end of the back side.

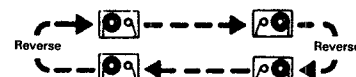

* The reverse recording/playback mode () is set automatically during recording.

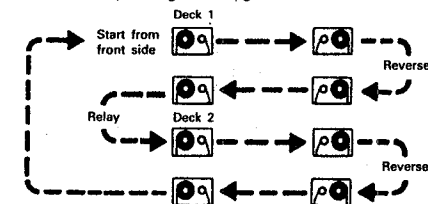

Storage Precautions

- Avoid storing in the following places:
 - Hot, humid places
 - Dusty places
 - Places exposed to direct sunlight
 - Near magnetic fields (TVs, speakers, etc.)
- Store the cassette tape in a case equipped with stoppers to keep the tape from coming slack.

Protecting Cassette Tapes From Being Erased Accidentally

- Cassette tapes are equipped with accidental erasure prevention tabs. To protect recorded tapes from being erased accidentally, use a screwdriver, etc., and break these tabs off.
- To record on a cassette tape whose accidental erasure prevention tabs have been broken off, place a piece of cellophane tape over the hole.

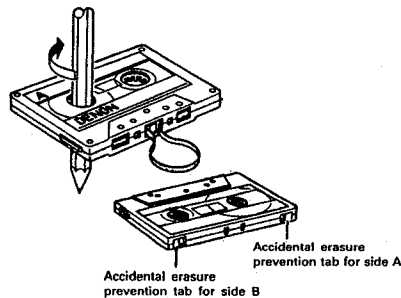

Accidental erasure prevention tab for side A
Accidental erasure prevention tab for side B

Before Operating



Loading and Unloading Cassette Tapes (Common for Deck 1 and Deck 2)

• Loading

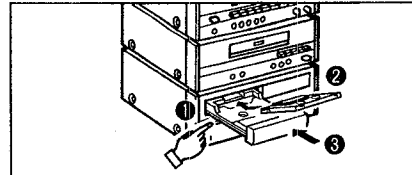
- ① Press the OPEN/CLOSE button () to open the cassette tray.
- ② Set the tape in the cassette tray with the open side (on which the tape is exposed) facing away from you.
- ③ Press the OPEN/CLOSE button again to close the tray.



• Unloading

- ① Press the STOP button ().
- ② Press the OPEN/CLOSE button () to open the cassette tray.
- ③ Remove the cassette tape.

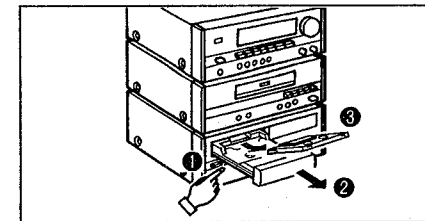

Check the following before recording or playing cassette tapes:

1. Is the head dirty?...
The sound quality will be poor if the head is dirty. Refer to Page 27.
2. Are the accidental erasure prevention tabs broken off?...
Recording is not possible if these tabs are broken off. Refer to Page 17.

NOTE:

- Load the cassette tape on an angle with the open side facing away from you. Loading it in the opposite direction can cause damage.
- Always press the STOP button before pressing the OPEN/CLOSE button.

Using the Tape Counter (Linear Tape Counter)

- This counter displays the elapsed running time of the tape in minutes and seconds.
- The counter can be reset to 00:00 by pressing the COUNTER RESET button. Or, the counter will also be reset when the tape is loaded or unloaded.
- Making a memo of the contents of a recording and the range of the counter numbers while you are recording or playing back a tape will be convenient when you search for a portion of the tape to which you would like to listen.

NOTE:

- This deck's linear tape counter has been set for the following cassette tape lengths: C46, C50, C54, C60, C74, C90, C100, C120, C46L, C50L, and C54L. (L indicates large-hubbed cassettes.) Using a tape that lies outside of this range, or a tape with a different length than the displayed lengths, will result in error. When using a tape that is not included in the TAPE SIZE selection, select the tape size closest to the length of the tape to be used. (This will reduce the error.)
- The linear tape counter is not accurate like a clock. The thickness of the tape will differ depending on the type of tape used (tape position and time), and so there will be some error introduced. Error also arises from the difference between tapes with smaller and larger hubs, and shows up in the remaining tape display.

Auto Tape Selector Mechanism

This deck is equipped with an auto tape selector mechanism which uses the detection holes in the cassette halves to automatically set the recording bias and equalization best suited for that type of tape.

- Do not use ferrichrome tapes.
- Use metal tapes equipped with detection holes. (Use of the old type of metal tape without detection holes will result in the sound having an emphasized treble region.)

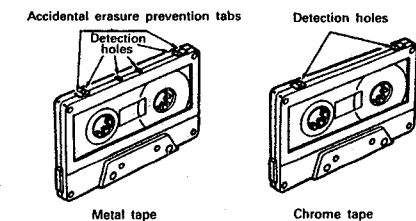

9 PLAYING CASSETTE TAPES

Single Side Playback, Two-Side Playback, and Continuous Playback

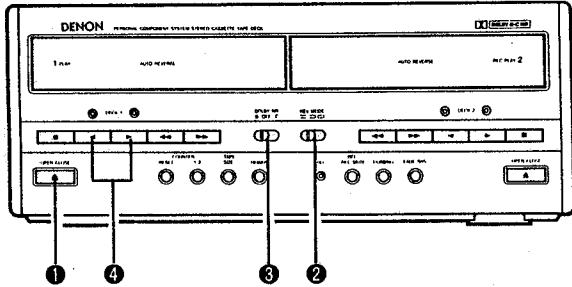

- Functions common for deck 1 and deck 2.
- When operating from the remote control unit, the operation switches between deck 1 and deck 2 each time the **DECK** 1/2 button is pressed. The counter indicator (1 or 2) lights for the selected deck.

<p>1</p> <p>Press the OPEN/CLOSE button, and load a recorded tape into the tray. Refer to Page 17.</p>		<p>Loading the tape</p> <p>The tape can be loaded easily by inserting it at an angle.</p>
<p>2</p> <p>Set the REV MODE switch. Refer to Page 17.</p>		<p>Removing the tape</p> <p>The tape can be removed easily by lifting it out toward yourself at an angle.</p>
<p>3</p> <p>Set the DOLBY NR switch. Refer to Page 7.</p>	<p>When the tape has been recorded with Dolby noise reduction, set the switch to the same type (B or C) that was used at the time of recording.</p>	
<p>4</p> <p>Press the play button (▶) or (◀).</p>	<p>Playback starts in the direction of the button pressed.</p>	<p>Press the stop button ■ to stop the playback.</p>

NOTE:

When the power has been disrupted due to a power failure or disconnection of the power cord plug from the outlet, press the play button of the deck twice in succession when the deck is to be played again.

Using the MS (Music Search) Function and the Music Search Display

Using the MS (Music Search) Function

Use this function to move to the beginning of the following section or return to the beginning of the current selection.

- 1 Press ▶ or ◀.
- 2 Press ►► or ◀◀.

- In the rewind direction, playback starts from the beginning of the selection which is currently playing, and in the fast-forward direction, playback starts from the beginning of the following selection.

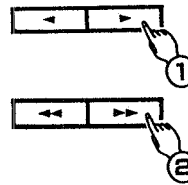

The tape skips by a number of selections equal to the number of times the ►► or ◀◀ button is pressed. For example:

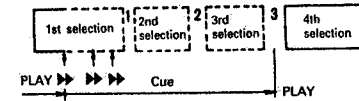

- For the normal fast-forward or rewind operations, press the stop button ■ before pressing the ►► or ◀◀ button.

Display During the Music Search Operation

During the music search operation, the number of selections being skipped is indicated on the tape counter, and this number decreases each time a blank section is detected (for example, 3 → 2 → 1).

- When skipping back to a previous selection

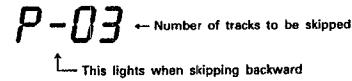

- When skipping ahead to a following selection



10 RECORDING CASSETTE TAPES

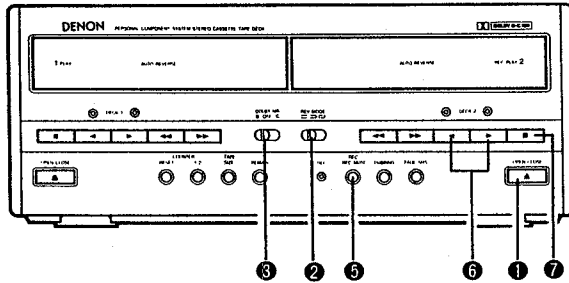

• The positions of the VOLUME and tone controls do not affect the sound being recorded.

1	<p>Press the OPEN/CLOSE button for deck 2 and load the tape to which you will record. Refer to Page 17.</p>		
2	<p>Set the REV MODE switch to or . Refer to Page 17.</p> <p>Single-side recording Two-side (reverse) recording.</p>		
3	<p>Set the DOLBY NR switch. Refer to Page 7 . Set to B or C to record with Dolby Noise Reduction.</p> <p>DOLBY NR B OFF C</p>		
4	<p>Recording from the radio</p> <p>Press the BAND selector button.</p> <p>Select the station you wish to record. (Refer to Page 10.)</p>	<p>Recording from a VDP</p> <p>Press the tuner-preamplifier's FUNCTION button and select AUX.</p> <p>Start playback on the VDP.</p>	<p>Recording from a CD player</p> <p>Set the disc in the CD player. (Refer to Page 21.)</p>
	5	<p>Press the REC/REC MUTE button. . The REC (recording) indicator lights.</p>	(5) FADE SRS
6	<p>Press the or button. (Recording starts)</p> <p>LED lights. </p>	<p>Press the FADE SRS button. The FADE SRS indicator lights and recording starts.</p>	
7	<p>To stop recording, press the stop button. </p>		

About Fade SRS Recording

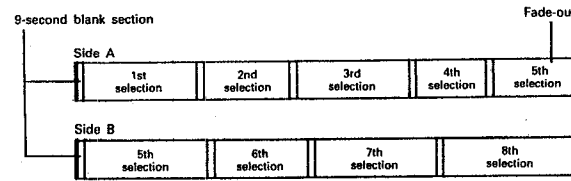

- ① The tracks are recorded in order starting from the first track.
- ② Tracks which are interrupted at the end of the tape (side A and side B) are faded out.
- ③ The track which has faded out at the end of side A is recorded over at the beginning of side B, and recording stops.

• Fade-out function

During the CD synchro recording (CD SRS) function, when a track cannot be recorded in its entirety at the end of side A or B, the fade-out function gradually reduces the recording level during the last 20 seconds (20 seconds from the end of the tape).

NOTE:

- A blank portion between the tracks of about 4 seconds is created automatically in fade SRS recording. Therefore, a normal recording may not be possible when the last track of side A or side B is as follows:
Example: Tracks in which pianissimo (i.e., low level sound portions) continues for a lengthy period
- When FADE SRS recording is started from part way through the tape, recording will not be possible when less than about 40 seconds remain on the tape.
- Do not press the FUNCTION (input switching) button or the CD pause button (II) during FADE SRS recording.
- When switching off the power during fade SRS recording, press the stop button (■) to stop the recording and then switch off the power.
- Press the FADE SRS button when the CD is stopped.

• Making a Synchro Dubbing (Copy)

Synchro dubbing (tape copying) can be made at regular speed from deck 1 to deck 2.

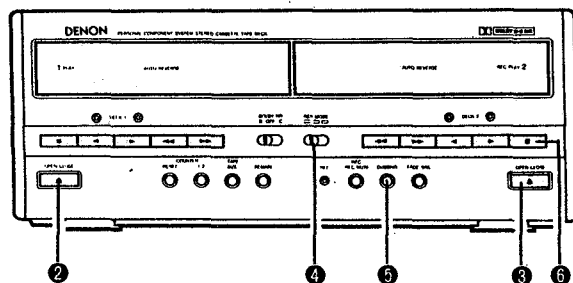

- ① Press the SYSTEM POWER button of the receiver.
- ② Press the OPEN/CLOSE (▲) button and load the tape to be played back in deck 1.
- ③ Press the OPEN/CLOSE (▲) button and load the tape to be recorded back in deck 2.
- ④ Set the reverse mode with the REV MODE switch.
(REV MODE : ◀ : ▶)
- ⑤ Press the DUBBING (synchro dubbing) button. Note that if the POWER ON/STANDBY button of the deck is pressed to switch on the power, the power of the receiver will automatically be switched on when the DUBBING button is pressed. You will be able to hear the audio normally.
- ⑥ To stop the dubbing, press the stop button (■) or press the DUBBING button.
The tape will automatically stop when it reaches the end and the synchro dubbing mode will be cancelled.

• Dolby NR mode during synchro dubbing

The Dolby NR system is automatically disengaged from the panel switch during synchro dubbing (even though the display does not change) and the tape is recorded with the Dolby NR mode of the playback tape.

• You can listen to the sound of another source while synchro dubbing.

To listen to the sound of the source during synchro dubbing, press the forward play (▶) button or the reverse play (◀) button of deck 1.

• When synchro dubbing, both decks begin running in the forward direction (from the A side).

• The synchro DUBBING button is effective in starting the operation only when both tapes are in the stopped condition.

• The following buttons do not function during the synchro dubbing operation: forward play ▶, reverse play ◀, fast forward ▶▶, rewind ◀◀, and REC/REC MUTE.

• To ensure complete reproduction, use the same length of recording tape as the playback tape, and rewind both tapes to the beginning of side A before starting the dubbing operation.

• By setting the REV MODE switch to the ◀ or ▶ position, when the playback tape of deck 1 reverses at the end of the tape on side A, the deck 2 tape will reverse at the same time and dubbing can continue on side B.

• Match the tape size before the start of dubbing.

During dubbing, only the tape size setting of the deck 2 side can be changed.

11 PLAYING CDs

Compact Discs

- Press the OPEN/CLOSE button (▲) once to open the disc tray, once again to close it.
- The disc tray can also be closed by pressing the play (▶) button.
When this is done, playback automatically starts from the first track on the disc (or if the tracks are programmed, the first programmed track).
- When the disc tray is closed, the disc turns automatically for several seconds, and the number of tracks and total playing time appear on the display.



Only discs with this mark can be played.

When removing the disc from its case:

As shown in the diagram, grasp the disc along the edges, gently press down on the hole in the middle with a finger, and lift the disc. It should come out easily.



When setting the disc in the disc tray:

Always set the disc with the label side facing up. (Compact discs can only be played on one side). For 8 cm CDs, set the disc in the sunken part in the middle of the tray.

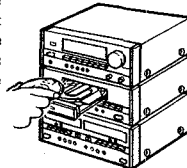

- For CDVs, only the audio part is played (the video part is not played).

Disc	Remarks
CD	
CDV	Only the audio part is played.
CD single (8 cm)	

Handling the Disc Tray

Do not switch off the power or push or pull the disc tray when it is moving, since this may damage it.
If the cord of a set of headphones, etc., gets caught in the disc tray when it is closed, press the OPEN/CLOSE button (▲) again.

- Never set objects other than CDs in the disc tray, as this can cause damage.

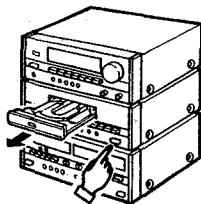

Regular Play

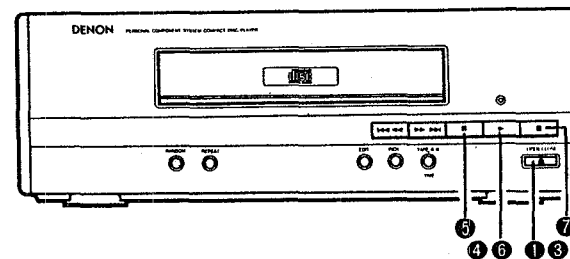

Example: Playing a CD with 15 tracks and a total playing time of 62 minutes 03 seconds, starting from track 1

1	Press the OPEN/CLOSE button. The disc tray opens.		TRACK 00 00'00" 1 2 3 4 5 6 7 8 9 10 11 12 13 14 15
2	Set the CD in the disc tray. Refer to Page 21. The display appears several seconds after the disc tray closes.		
3	Press the OPEN/CLOSE button. The disc tray closes.		TRACK 15 62'03" 1 2 3 4 5 6 7 8 9 10 11 12 13 14 15
4	Press the play button. LED lights. CD play starts.		TRACK 01 00'01" 1 2 3 4 5 6 7 8 9 10 11 12 13 14 15

To stop play temporarily:

5	Press the pause button. "▶ PLAY" goes off and " PAUSE" appears. CD play is paused at the point the button is pressed.		
---	--	--	--

To resume CD play:

6	Press the play button. " PAUSE" goes off and "▶ PLAY" appears. CD play resumes from the point the pause button was pressed.		
---	--	--	--

To stop CD play:

7	Press the stop button. TRACK 15 62'03" 1 2 3 4 5 6 7 8 9 10 11 12 13 14 15		
---	---	--	--

NOTES:

- When a disc is loaded, the track number display first reads "00" while the data for the number of tracks on the disc and the playing time, etc., is read (several seconds), after which the total number of tracks and total playing time appear.
- The display reads as follows if no disc is loaded, if the disc is loaded upside-down, or if the data cannot be read due to heavy scratches or dirt:

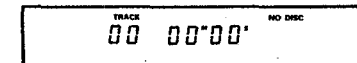

Various CD Play Functions

(Insert the disc before performing the following operations.)

① Playing Certain Tracks

DIRECT SELECTION

Example: Playing the 8th track
Perform this operation from the remote control unit.

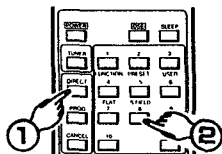

- ① Press the DIRECT button.
- ② Press track button "8". "TRACK 8" appears on the display, and the 8th track begins playing.
 - When the end of the track is reached, play continues on to the next track.

- For track numbers of 11 and higher, for example 15, press [+10] and [5]. For track numbers of 20 and higher, for example 23, press [+10], [+10], and [3]. For track number 20, press [+10] and [10].

② Playing 1 Track Repeatedly

1 TRACK REPEAT

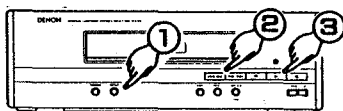

- ① Press the REPEAT button once.
- ② Press the [REVERSE] or [SKIP] button, and select the desired track.
- ③ Press the play button (▶) to start play.

- When the specified track finishes playing, the pickup returns to the beginning of that track and play is repeated.
- If the REPEAT button is pressed once during play, the track will be played repeatedly.
- If the REPEAT button is pressed once during programmed play, the track will be played repeatedly.
- If the REPEAT button is pressed once while the disc is stopped, the TRACK numbers indicator flashes and the 1 track repeat play mode is set.

③ Playing All Tracks Repeatedly

ALL TRACKS REPEAT

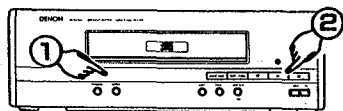

- ① Press the REPEAT button twice.
- ② Press the play button (▶) to start play.

- When the last track finishes playing, the pickup returns to the first track of the disc and play is repeated.
- If the REPEAT button is pressed twice during play, the disc will be played repeatedly.
- If the REPEAT button is pressed twice during programmed play, the program will be played repeatedly.
- If the REPEAT button is pressed twice while the disc is stopped, the TRACK numbers indicator lights and the all tracks repeat play mode is set.

④ Playing a Specific Section Repeatedly

SECTION REPEAT

Example: The CD has a total of 15 tracks

1st time	(1) Press the REPEAT button during CD play.	Only that track is played repeatedly, and that track number lights on the music calendar. * With a 1-track repeat of track 21 or higher, "TRACK No." flashes.
	(2) Press the REPEAT button before CD play.	The total number of tracks flashes, and then ① the first track is repeated by pressing the play button ② when play is started by direct selection from the remote control or with the [SKIP] or [REVERSE] button, only those selected tracks are played repeatedly.
2nd time	(1) Press the REPEAT button before CD play or during CD play.	
	(2) Press the REPEAT button before CD play or during CD play.	The track numbers contained on the disc light up on the music calendar, and all tracks are played repeatedly.
3rd time	Press the REPEAT button during CD play.	"REPEAT A-" lights up. If nothing else is done, all tracks are played repeatedly.
4th time	Press the REPEAT button during CD play.	"REPEAT A-B" lights up. The A-B section is played repeatedly.

Pressing the REPEAT button once again returns the player to regular CD play.

⑤ Playing Certain Tracks in any Desired Order
 (Perform this operation from the remote control unit.)

PROGRAMMED SELECTION

Example: Programming track 3 to play first, track 18 to play second, on a CD with 18 tracks and a total playing time of 62 minutes, 3 seconds

Setting and Playing the Program

1	Press the PROGRAM button.		TRACK 18 62'03"
2	Set track 3 to play first.		TRACK 03 08'00"
3	Set track 18 to play second.		TRACK 18 16'05"
4	Press the play button.		TRACK 18 16'05"

After 2 seconds
 The display when track 3 is set to play first
 Time of first track: 8 minutes, 00 seconds

After 2 seconds
 The display when track 18 is set to play second
 Total time of tracks 1 and 2: 16 minutes, 05 seconds

The tracks start playing in the programmed order.

- The numbers of the programmed tracks go off once the tracks are played.
- The time display will read "—M—S" if a track number of 31 or higher is set in the program.
- When a program is set during CD play after a direct selection, the track currently playing is set as the first track in the program.
- Up to 20 tracks of your choice from among track numbers 1 through 99 can be programmed with this CD player.
- If you attempt to set a track number that is greater than the number of tracks on the disc, that track number will not be displayed when the buttons are pressed.
- Programming is also possible when the disc tray is open. In this case, track numbers greater than the number of tracks on the disc can be programmed, but these are ignored when the disc is played.
- There is a silent interval of 4 seconds between tracks. This is has been designed to create a blank section of 4 seconds between selections when recording programmed tracks onto tape.
- The entire program is cleared when the disc tray is opened or closed (by pressing the button).
- If you make a mistake when programming tracks, press the CANCEL button and program again. (Each press of the CANCEL button cancels the last track.)
- An A-B section repeat is not possible during programmed play.
- Other operations possible during programmed play:
 The quick search, pause, skip monitor, and other operations can be used during programmed play. To move to the beginning of the previous track with the quick search operation, press once, then once again while the time display reads "00'00.". To move to the beginning of the following track, press once, regardless of the time display.
- Perform programming and canceling in the stop mode.

⑥ Moving to the Next Track During CD Play

QUICK SEARCH

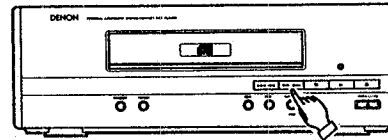

- Press the auto search forward button ().
- Each press of the auto search forward button () moves the pickup to the beginning of following tracks.

⑦ Moving Back to the Beginning of the Current Track During CD Play

QUICK SEARCH

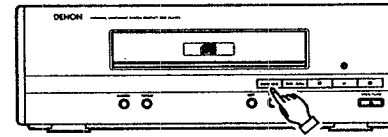

- Press the auto search backward button (.
- Each press of the auto search backward button () during the search operation moves the pickup to the beginning of previous tracks.

⑧ Searching for Tracks While Listening to the Sound

SKIP MONITOR

1 Forward skip monitor

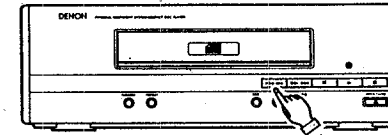

During CD play, press and hold in the forward search button () to skip forward while listening to the sound.

- Use this to skip through a disc listening to the sound at high speed.
- This function is convenient when searching for a certain section within a long track.
- Use the skip monitor function to find the desired position, then release the search button to start regular playback from there.

2 Backward skip monitor

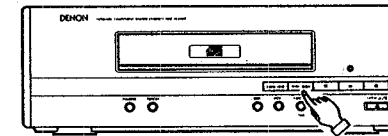

During CD play, press and hold in the backward search button () to skip backward while listening to the sound.

- The track number and elapsed playing time of the track being skipped through are on the display.
- If the end of the last track on the disc is reached while pressing the search button, () appears on the display and the skip monitor operation stops. To resume CD play, press the search backward button () until () switches to the track number, then perform a different operation.

- The track number and elapsed playing time of the track being skipped through are indicated on the display.
- If the beginning of the first track on the disc is reached while pressing the search button, () appears on the display and the skip monitor operation stops. To resume CD play, press the search forward button () until () switches to the track number, then perform a different operation.

If the forward or backward skip button is pressed during programmed CD play and released at a track which has not been programmed, the next programmed track will be played once that track has been played to the end.

●Playing Tracks in Random Order

- The function plays each track on the disc once in random order.

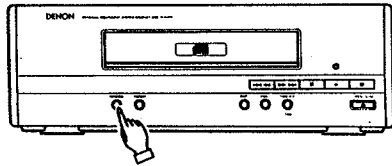

- A press of the RANDOM button lights the **RND** indicator to show that the random mode has been set. Random search will begin when the play button is pressed and the disc will start playing automatically.
- Simply pressing the RANDOM button during CD play will start the random search and start random play.

RANDOM SEARCH

- Pressing the RANDOM button when a program has been set will play the programmed tracks in random order.
- Pressing the RANDOM button when repeat play has been set will play the tracks through randomly one time, and each time following this there will be a random search with a different pattern.
- The A-B section repeat and the 1-track repeat are not possible during random play.
- During the search operation, the track numbers of the disc from track 1 to the last track will be repeatedly displayed at high speed in the TRACK NO. section, and the following tracks to be played will not be known from the end of the search to the time CD play begins.
- Pressing the RANDOM button when 1-track repeat has been set will automatically change the setting to all tracks repeat and these tracks will be played randomly.

NOTE:

Random play is not possible during the edit operation.

Edited Recording onto Sides A and B of a Tape (EDIT)

Editing is possible with CDs containing up to 20 tracks.

Before starting the edited recording operation, load the cassette tape to which you will record into deck 2 with side A facing up.

The leader tape is automatically taken up before recording starts.

(Set the REV MODE switch to the position.)

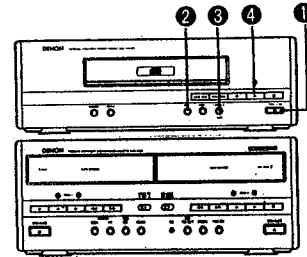

●Automatic Edited Recording

RECORDING IN THE SAME ORDER AS ON THE DISC

Example: Recording a disc with 18 tracks and a total playing time of 56 minutes onto a C-60 cassette tape

<p>1</p> <p>Press the OPEN/CLOSE button. → Set the disc. → Press the OPEN/CLOSE button. → Press the play button and set the function to CD. → Press the stop button.</p>	<table border="1"> <thead> <tr> <th>TRACK</th> <th>DISC</th> </tr> </thead> <tbody> <tr> <td>18</td> <td>56:00</td> </tr> <tr> <td>1</td> <td>2</td> </tr> <tr> <td>2</td> <td>3</td> </tr> <tr> <td>3</td> <td>4</td> </tr> <tr> <td>4</td> <td>5</td> </tr> <tr> <td>5</td> <td>6</td> </tr> <tr> <td>6</td> <td>7</td> </tr> <tr> <td>7</td> <td>8</td> </tr> <tr> <td>8</td> <td>9</td> </tr> <tr> <td>9</td> <td>10</td> </tr> <tr> <td>10</td> <td>11</td> </tr> <tr> <td>11</td> <td>12</td> </tr> <tr> <td>12</td> <td>13</td> </tr> <tr> <td>13</td> <td>14</td> </tr> <tr> <td>14</td> <td>15</td> </tr> <tr> <td>15</td> <td>16</td> </tr> <tr> <td>16</td> <td>17</td> </tr> <tr> <td>17</td> <td>18</td> </tr> </tbody> </table>	TRACK	DISC	18	56:00	1	2	2	3	3	4	4	5	5	6	6	7	7	8	8	9	9	10	10	11	11	12	12	13	13	14	14	15	15	16	16	17	17	18																																																								
TRACK	DISC																																																																																														
18	56:00																																																																																														
1	2																																																																																														
2	3																																																																																														
3	4																																																																																														
4	5																																																																																														
5	6																																																																																														
6	7																																																																																														
7	8																																																																																														
8	9																																																																																														
9	10																																																																																														
10	11																																																																																														
11	12																																																																																														
12	13																																																																																														
13	14																																																																																														
14	15																																																																																														
15	16																																																																																														
16	17																																																																																														
17	18																																																																																														
<p>2</p> <p>EDIT Press the EDIT button to set the tape length. Press the EDIT button four times when using a 60-minute (C 60) tape. (The tape length is to total time of sides A and B.) The display changes as follows each time the EDIT button is pressed. (When the tape time has already been set, the display will change in order starting at that time each time the EDIT button is pressed.)</p> <table border="1"> <tr> <td>C-46</td> <td>C-50</td> <td>C-54</td> <td>C-60</td> </tr> <tr> <td>46-minute tape</td> <td>50-minute tape</td> <td>54-minute tape</td> <td>60-minute tape</td> </tr> <tr> <td>C-00</td> <td>C-120</td> <td>C-100</td> <td>C-90</td> <td>C-74</td> </tr> <tr> <td>120-minute tape</td> <td>100-minute tape</td> <td>90-minute tape</td> <td>74-minute tape</td> <td></td> </tr> </table> <p>The desired recording time can be set when this is displayed. (Method 1)</p> <p>Example: For a 36-minute tape, use the or button to set 36. To set the tape length using the remote control unit, use the number buttons. For example, in the case of a 30-minute tape, press twice and press .</p> <p>If you make a mistake, press the EDIT button to display "C-00", then start over again.</p>	C-46	C-50	C-54	C-60	46-minute tape	50-minute tape	54-minute tape	60-minute tape	C-00	C-120	C-100	C-90	C-74	120-minute tape	100-minute tape	90-minute tape	74-minute tape		<p>Setting the desired recording time (Method 2) Select a tape length close to the desired time, then make a fine adjustment using the or button. For example, to set 51 minutes, select C-50, then press the button once to set C-51.</p> <table border="1"> <thead> <tr> <th>TRACK</th> <th>DISC</th> </tr> </thead> <tbody> <tr> <td>51</td> <td>56:00</td> </tr> <tr> <td>1</td> <td>2</td> </tr> <tr> <td>2</td> <td>3</td> </tr> <tr> <td>3</td> <td>4</td> </tr> <tr> <td>4</td> <td>5</td> </tr> <tr> <td>5</td> <td>6</td> </tr> <tr> <td>6</td> <td>7</td> </tr> <tr> <td>7</td> <td>8</td> </tr> <tr> <td>8</td> <td>9</td> </tr> <tr> <td>9</td> <td>10</td> </tr> <tr> <td>10</td> <td>11</td> </tr> <tr> <td>11</td> <td>12</td> </tr> <tr> <td>12</td> <td>13</td> </tr> <tr> <td>13</td> <td>14</td> </tr> <tr> <td>14</td> <td>15</td> </tr> <tr> <td>15</td> <td>16</td> </tr> <tr> <td>16</td> <td>17</td> </tr> <tr> <td>17</td> <td>18</td> </tr> </tbody> </table> <p>"EDIT" flashes for 2 seconds</p> <p>2 minutes 40 seconds extra on side A</p> <table border="1"> <thead> <tr> <th>TRACK</th> <th>DISC</th> </tr> </thead> <tbody> <tr> <td>A1</td> <td>02:40</td> </tr> <tr> <td>1</td> <td>2</td> </tr> <tr> <td>2</td> <td>3</td> </tr> <tr> <td>3</td> <td>4</td> </tr> <tr> <td>4</td> <td>5</td> </tr> <tr> <td>5</td> <td>6</td> </tr> <tr> <td>6</td> <td>7</td> </tr> <tr> <td>7</td> <td>8</td> </tr> <tr> <td>8</td> <td>9</td> </tr> <tr> <td>9</td> <td>10</td> </tr> <tr> <td>10</td> <td>11</td> </tr> <tr> <td>11</td> <td>12</td> </tr> <tr> <td>12</td> <td>13</td> </tr> <tr> <td>13</td> <td>14</td> </tr> <tr> <td>14</td> <td>15</td> </tr> <tr> <td>15</td> <td>16</td> </tr> <tr> <td>16</td> <td>17</td> </tr> <tr> <td>17</td> <td>18</td> </tr> </tbody> </table> <p>Tracks for side A light up. Tracks for side B flash. (Tracks 1 through 9 are recorded on side A.) (Tracks 10 through 18 are recorded on side B.)</p>	TRACK	DISC	51	56:00	1	2	2	3	3	4	4	5	5	6	6	7	7	8	8	9	9	10	10	11	11	12	12	13	13	14	14	15	15	16	16	17	17	18	TRACK	DISC	A1	02:40	1	2	2	3	3	4	4	5	5	6	6	7	7	8	8	9	9	10	10	11	11	12	12	13	13	14	14	15	15	16	16	17	17	18
C-46	C-50	C-54	C-60																																																																																												
46-minute tape	50-minute tape	54-minute tape	60-minute tape																																																																																												
C-00	C-120	C-100	C-90	C-74																																																																																											
120-minute tape	100-minute tape	90-minute tape	74-minute tape																																																																																												
TRACK	DISC																																																																																														
51	56:00																																																																																														
1	2																																																																																														
2	3																																																																																														
3	4																																																																																														
4	5																																																																																														
5	6																																																																																														
6	7																																																																																														
7	8																																																																																														
8	9																																																																																														
9	10																																																																																														
10	11																																																																																														
11	12																																																																																														
12	13																																																																																														
13	14																																																																																														
14	15																																																																																														
15	16																																																																																														
16	17																																																																																														
17	18																																																																																														
TRACK	DISC																																																																																														
A1	02:40																																																																																														
1	2																																																																																														
2	3																																																																																														
3	4																																																																																														
4	5																																																																																														
5	6																																																																																														
6	7																																																																																														
7	8																																																																																														
8	9																																																																																														
9	10																																																																																														
10	11																																																																																														
11	12																																																																																														
12	13																																																																																														
13	14																																																																																														
14	15																																																																																														
15	16																																																																																														
16	17																																																																																														
17	18																																																																																														
<p>3</p> <p>A/B button is pressed. (Use this to check the extra time on side B.)</p> <p>The display changes between sides A and B each time the TAPE</p>	<table border="1"> <thead> <tr> <th>TRACK</th> <th>DISC</th> </tr> </thead> <tbody> <tr> <td>B</td> <td>01:20</td> </tr> <tr> <td>1</td> <td>2</td> </tr> <tr> <td>2</td> <td>3</td> </tr> <tr> <td>3</td> <td>4</td> </tr> <tr> <td>4</td> <td>5</td> </tr> <tr> <td>5</td> <td>6</td> </tr> <tr> <td>6</td> <td>7</td> </tr> <tr> <td>7</td> <td>8</td> </tr> <tr> <td>8</td> <td>9</td> </tr> <tr> <td>9</td> <td>10</td> </tr> <tr> <td>10</td> <td>11</td> </tr> <tr> <td>11</td> <td>12</td> </tr> <tr> <td>12</td> <td>13</td> </tr> <tr> <td>13</td> <td>14</td> </tr> <tr> <td>14</td> <td>15</td> </tr> <tr> <td>15</td> <td>16</td> </tr> <tr> <td>16</td> <td>17</td> </tr> <tr> <td>17</td> <td>18</td> </tr> </tbody> </table> <p>1 minute 20 seconds extra on side B. Tracks for side A flash. Tracks for side B light up.</p>	TRACK	DISC	B	01:20	1	2	2	3	3	4	4	5	5	6	6	7	7	8	8	9	9	10	10	11	11	12	12	13	13	14	14	15	15	16	16	17	17	18																																																								
TRACK	DISC																																																																																														
B	01:20																																																																																														
1	2																																																																																														
2	3																																																																																														
3	4																																																																																														
4	5																																																																																														
5	6																																																																																														
6	7																																																																																														
7	8																																																																																														
8	9																																																																																														
9	10																																																																																														
10	11																																																																																														
11	12																																																																																														
12	13																																																																																														
13	14																																																																																														
14	15																																																																																														
15	16																																																																																														
16	17																																																																																														
17	18																																																																																														
<p>4</p> <p>Press the play button.</p>	<table border="1"> <thead> <tr> <th>TRACK</th> <th>DISC</th> </tr> </thead> <tbody> <tr> <td>01</td> <td>01:21</td> </tr> <tr> <td>1</td> <td>2</td> </tr> <tr> <td>2</td> <td>3</td> </tr> <tr> <td>3</td> <td>4</td> </tr> <tr> <td>4</td> <td>5</td> </tr> <tr> <td>5</td> <td>6</td> </tr> <tr> <td>6</td> <td>7</td> </tr> <tr> <td>7</td> <td>8</td> </tr> <tr> <td>8</td> <td>9</td> </tr> <tr> <td>9</td> <td>10</td> </tr> <tr> <td>10</td> <td>11</td> </tr> <tr> <td>11</td> <td>12</td> </tr> <tr> <td>12</td> <td>13</td> </tr> <tr> <td>13</td> <td>14</td> </tr> <tr> <td>14</td> <td>15</td> </tr> <tr> <td>15</td> <td>16</td> </tr> <tr> <td>16</td> <td>17</td> </tr> <tr> <td>17</td> <td>18</td> </tr> </tbody> </table>	TRACK	DISC	01	01:21	1	2	2	3	3	4	4	5	5	6	6	7	7	8	8	9	9	10	10	11	11	12	12	13	13	14	14	15	15	16	16	17	17	18																																																								
TRACK	DISC																																																																																														
01	01:21																																																																																														
1	2																																																																																														
2	3																																																																																														
3	4																																																																																														
4	5																																																																																														
5	6																																																																																														
6	7																																																																																														
7	8																																																																																														
8	9																																																																																														
9	10																																																																																														
10	11																																																																																														
11	12																																																																																														
12	13																																																																																														
13	14																																																																																														
14	15																																																																																														
15	16																																																																																														
16	17																																																																																														
17	18																																																																																														

- Note that in some cases, even if the tape is longer than the total playing time on the disc, it may not be possible to record all the tracks onto the tape, since they are divided onto sides A and B. In such cases, the OVER indicator flashes.

NOTE:

- With edited recording, side B of the tape will be recorded automatically even when the REV MODE switch of the deck is set to the position.
 - During edit recording, buttons other than the following will not be operational: CD stop button and OPEN/CLOSE button, TAPE A/B button, TIME button, deck stop button, OPEN/CLOSE button of deck 1, button, button, COUNTER RESET button, and COUNTER 1/2 button.
 - When using a recorded tape for edited recording, the tape should be erased before use, since when the tape is longer than the set time, an unrecorded section of side B will remain after the tape stops.
- When a tape which has been recorded with this system is played back, there will be 4-second blank portions between tracks (for making it easy to reach the beginning of a track). This will differ from the actual silent portions between the tracks on the disc, and so there will be some error in the actual remaining time of the tape and the displayed time.

Convenient Functions for Edited Recording onto Tapes

Pick Function **PICK**

With automatic edited recording or programmed edited recording (see pages 25), the tracks are recorded in order from the first track on the disc or in the programmed order, so in some cases long empty sections may be left at the end of the tape. The pick function reduces the length of these empty sections.

The pick function is set after completing the settings for automatic edited recording or programmed edited recording and before pressing the play () button. (Just press the PICK button. The rest is performed automatically.)

Programmed Edited Recording **RECORDING CERTAIN TRACKS IN ANY DESIRED ORDER**

- 1 Follow the instructions under "PROGRAMMED SELECTION" on Page 23 to program the tracks.
- 2 Perform steps 2 through 4 under the aforementioned "Automatic Edited Recording".

Programmed CD Play Using the Search Buttons (|<<< >>>|)

Pressing the PROGRAM button of the remote control unit will light up the "PROGRAM" indicator. When the disc is stopped, programming can be done with the search buttons (|<<< >>>|) on the CD player.

- Select the tracks with the search buttons, then press the PROGRAM button to program them.
- The search buttons (<< >>) can be used to change the track numbers continuously.
- After the track numbers have been selected with the search buttons, if the play button is pressed to start CD play before the PROGRAM button is pressed, the last track of the program set up to this point will be played. In this case, the tracks selected with the search buttons will not be programmed.

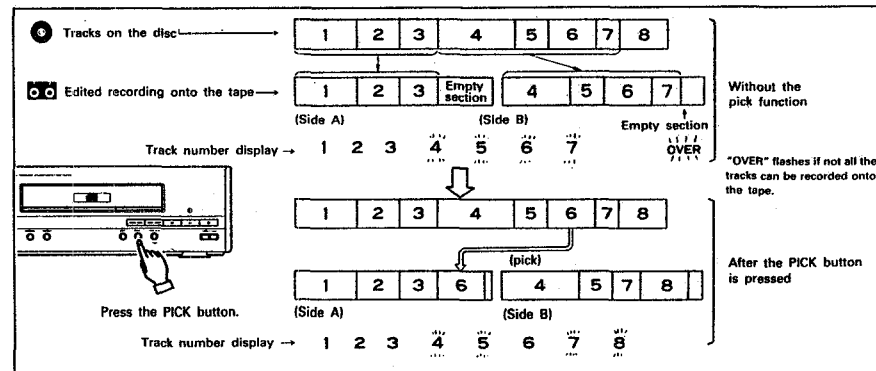

After pressing the PICK button, press the play button to start recording.

Example of cases when there is no track which fits in the empty section

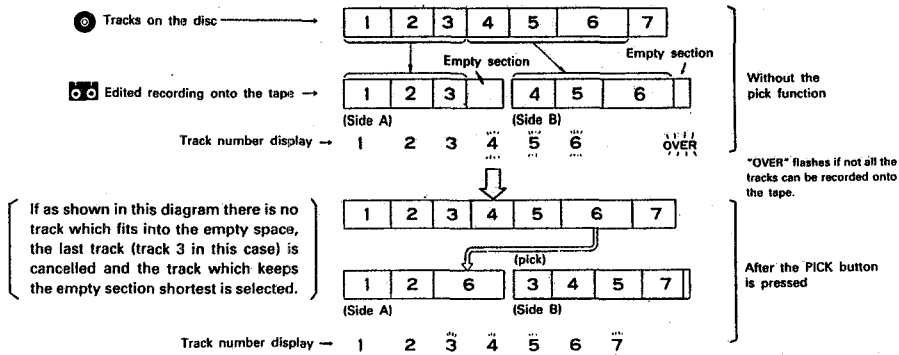

If as shown in this diagram there is no track which fits into the empty space, the last track (track 3 in this case) is cancelled and the track which keeps the empty section shortest is selected.

12 REMOTE CONTROL UNIT

Cautions on Use

1. The D-65 is supplied with a remote control unit (RC-164) for system control.
2. Replace the batteries with new ones when the transmission distance possible with the remote control unit shortens.
3. For longer battery life, remove the batteries when not using the remote control unit for long periods.
4. When replacing batteries, use two new batteries. Never use an old battery with a new one.
5. Do not use two different types of batteries.
6. Do not heat batteries or take them apart.
7. Be careful that the remote control sensor is not exposed to direct sunlight or strong light from lighting fixtures.
8. The remote control sensor is located on the tuner. Point the remote control unit at the sensor, then press the buttons for the desired operation.
9. Operate the remote control unit within the range illustrated in the diagram.

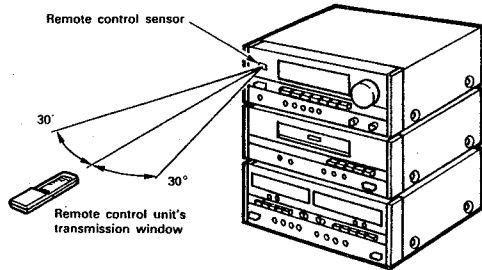

Inserting the Batteries

① Open the battery case lid on the back of the remote control unit.

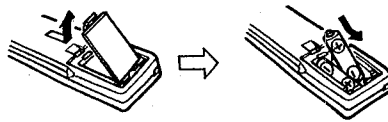

② Insert the two batteries (R6P, AA) in the proper direction.

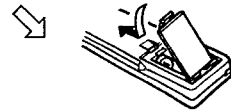

③ Set the battery case lid back in place.

appears at the upper left corner of the receiver's display when a signal is received.

• The remote control unit can be used at a distance of about 7 meters from the remote control sensor, but this distance will be shorter if there are obstacles in the way or if the remote control is operated from an angle.

10. Do not press buttons on the remote control unit and on the main unit at the same time. Doing so will lead to a malfunction.
11. If appears on the receiver's display due to incident light even though the remote control unit has not been operated, it is best to move the set or place it in a different direction. Even if this happens, it will not cause a malfunction with remote control unit.
12. When adjusting the volume continuously with the remote control unit, the volume adjustment will stop if the remote control unit is moved away from the remote control sensor. Should this happen, press the button again to continue changing the volume.

Button Names and Functions

DSE button
Press this when using the separately sold DSE-65. When pressed, the functions of the number buttons switches to the operations indicated underneath the buttons.

POWER
Press this to switch on the power for the entire system or set the system to standby.

TUNER
Press this to listen to the preset stations.

CD Play
DIRECT button
Press for direct track selection of CD player.
PROGRAM button
Press for programmed selection of CD player.
CANCEL button
Press once during programming to cancel the last track programmed.

Operating the CD Player
Stop button (■)
Press to stop CD play.
Play button (▶)
Press to start CD play.
Manual search backward button (◀◀)
Manual search forward button (▶▶)
Press these to quickly move backward or forward.

SDB (Super Dynamic Bass)
Press this button for more powerful bass sound. Press again to return to the original setting.

SLEEP
Press this to set the sleep timer.

Number buttons
After pressing TUNER, these buttons call up the preset stations. When used with CD play, after pressing DIRECT or PROGRAM, these buttons specify the tracks to be played.

Operating the Cassette Decks
Deck 1/2 button
Press this to select the deck to be operated.
Stop button (■)
Press this to stop the tape deck.
Forward play button (▶)
Press this to play back or record in the forward direction.
Reverse play button (◀)
Press this to play back or record in the reverse direction.
REC/REC MUTE button (recording/recording mute button)
To set the recording mode when in the stop mode, press this button, then press either the "▶" or the "◀" button. When pressed during the recording or recording pause mode, a blank section of approximately 5 seconds is created on the tape, after which the deck is set to the recording pause mode.
Rewind button (◀◀)
Press this to rewind the tape.
Fast-forward button (▶▶)
Press this to fast-forward the tape.

MASTER VOLUME
Adjusts the volume. Press V to lower the volume, and ▲ to raise it.

When the DSE button is pressed, number buttons 1, 2, 3, 4 and 5 operate as shown below. Use this when using the separately sold DSE-65.
 Button 1 → Function
 Button 2 → Preset
 Button 3 → User
 Button 4 → Flat
 Button 5 → S. field

13 AUTO ON FUNCTION

- When the CD or deck play button, or the OPEN/CLOSE button is pressed from the standby mode, the power is switched on automatically, and the play or open/close operation is performed.
- The power also turns on when the tuner number buttons (preset buttons) on the remote control unit are pressed.

14 IMPORTANT INFORMATION

• Head Cleaning

After the cassette deck has been used for a while, powder from the tapes and dirt adhere to the head and lower the sound quality.

Use a head cleaning cassette tape to clean.

NOTE:

Some of the cleaning sets on the market have a strong polishing effect which can damage the head.

• Disc Cleaning

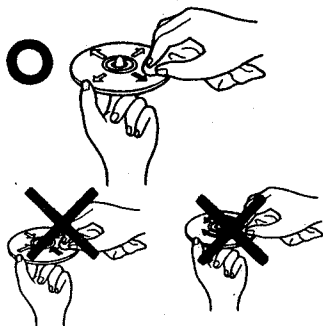

Never use the following to clean discs:

- Solvents such as benzene or alcohol
- Cleaners containing abrasives
- Record sprays or cleaners
- Anti-static products

• Head Demagnetizing

The heads become magnetized after the deck has been used over a long period of time or if the heads are exposed to a magnetic field. This results in noise and reduced treble. In addition, there may be a reduction of the treble range of recorded tapes as well as noise produced on these tapes. When the heads become magnetized, use one of the cassette tape head demagnetizers (erasers) available on the market to demagnetize the heads.

- For details, read the operating instructions of the demagnetizer.

Dust, fingerprints, or spittle on the disc can cause noise or skipping.

If the disc is dirty or if the player does not work properly, clean the disc as follows:

- Hold the disc as shown in the diagram, with the signal surface facing up (and the labelled side facing down).
- Using a soft cloth, wipe the disc gently from the inside straight towards the edges (as shown by the arrows).

- Do not wipe from the edges towards the center, or around the disc as you would wipe records.
- Do not use hard cloths or rub the disc forcefully, since the signal surface is susceptible to scratches.

15 SPECIFICATIONS

• Receiver (UDRA-65)

Amplifier

Practical maximum output: 30 W + 30 W (RMS)

Bass adjustment: 100 Hz ± 8 dB

Treble adjustment: 10 kHz ± 8 dB

SDB (Super Dynamic Bass): 80 Hz ± 8 dB

Terminals:

AUX:

PROCESSOR LOOP:

Headphones jack:

Mono out:

Surround out:

Input jacks (input sensitivity – 150 mV/47 kohm)

(input sensitivity – 150 mV/47 kohm)

3.5 mm mini size

Output jacks (rated output – 2.5 V)

Output jacks

Tuner

Receivable frequency range:

FM: 87.50 MHz ~ 108.00 MHz

AM: 522 kHz ~ 1611 kHz

Reception sensitivity

FM: 2 µV/75 ohm

AM: 20 µV/m

FM stereo separation:

35 dB (1 kHz)

Maximum external dimensions:

270 (W) × 103 (H) × 324 (D) mm (10-5/8" × 4-1/16" × 12-3/4")

Weight:

5.3 kg

Power supply:

AC 230 V, 50 Hz, AC 240 V, 50 Hz (for U.K. model)

Power consumption:

95 W

• CD player (UCD-65)

Wow & flutter:

Below measurable limits (±0.001% W. peak)

Sampling frequency:

44.1 kHz

Optical source:

Semiconductor

Maximum external dimensions:

270 (W) × 89 (H) × 306 (D) mm (10-5/8" × 3-25/32" × 12-3/64")

Weight:

2.4 kg

• Cassette deck (UDR-65)

Type:

Horizontal 4-track 2-channel auto reverse stereo cassette deck

Heads:

Hard permalloy recording/playback head × 1

Hard permalloy playback head × 1

Double gap ferrite erasing head × 1

Tape speed:

4.75 cm/s

Included circuit:

Dolby B and C Noise Reduction

Usable tapes:

Normal, chrome and metal

Maximum external dimensions:

270 (W) × 103 (H) × 306 (D) mm (10-5/8" × 4-1/16" × 12-3/64")

Weight:

3.6 kg

• Speakers (USC-65)

Type:

3-way 3-speaker bass reflex type

Speakers used:

13 cm woofer, 5 cm tweeter and 2.5 cm tweeter

Maximum tolerable input:

60 W

Impedance:

8 ohm

Maximum external dimensions:

192 (W) × 384 (H) × 276 (D) mm (7-9/16" × 15-1/8" × 10-55/64")

Weight:

4.9 kg per speaker

• Remote control unit (RC-164)

Type:

Infrared pulse

Number of buttons:

32

Maximum external dimensions:

55 (W) × 180 (H) × 18 (D) mm (2-11/64" × 7-3/32" × 45/64")

Weight:

100 g (including batteries)

- * Maximum dimensions include controls, jacks, and covers. (W) = width, (H) = height, (D) = depth
- For improvement purposes, specifications and functions are subject to change without advanced notice.

16 TROUBLESHOOTING

1. Check that the connections are proper.
 2. Check that you are operating the system according to the instructions in the manual.
- Check the following table if the system does not seem to be working properly.
If the problem is not solved after checking these points carefully, the system may be malfunctioning. Switch off the power and contact your store of purchase.

	Symptom	Cause	Measures	Page
Common	Power does not come on when POWER button pressed.	● Power cord not plugged into outlet.	● Plug cord into outlet properly.	5
	No sound produced from speakers.	● VOLUME control set to minimum. ● Headphones are plugged in. ● Speaker cables not connected to speaker terminals.	● Turn VOLUME control clockwise (↻). ● Disconnect headphones. ● Connect speaker cables properly.	6 6 5
	Treble not produced. Orientation of sound field not clear.	● Speaker polarities (⊕ and ⊖) not matched.	● Connect speaker cables properly.	5
	Source other than the desired one is heard.	● Function selector button not set properly.	● Set to desired function.	6
Deck	Cannot record when REC/REC MUTE button pressed.	● No cassette tape loaded. ● Accidental erasure prevention tabs of cassette broken off.	● Load tape. ● Apply cellophane tape over holes.	17 17
	Sound is interrupted during playback and recording, or treble sound is low.	● Head dirty. ● Tape stretched.	● Clean. ● Replace tape.	27 -
	Wow (fluctuation) is heavy during playback and recording.	● Capstans and pinch rollers dirty.	● Clean.	27
	Buzzing noise heard during playback.	● Noise from TV. ● (Some TVs produce noise.)	● Separate TV from system. ● Turn off TV.	- -
Receiver	Hissing noise heard during FM reception.	● Antenna not pointed in proper direction. ● Signals weak.	● Change direction of antenna. ● Install outdoor antenna.	4 4
	Hissing or scratchy noise heard during AM reception.	● Noise from TV, etc., or interference from other stations.	● Turn off TV. ● Change position of loop antenna. ● Install outdoor antenna.	- - 4
	Hum noise heard during AM reception.	● Signals coming over power cord are modulated by power source frequency.	● Plug in cord in opposite direction. ● Install outdoor antenna.	5 4
CD Player	Disc loaded but total number of tracks not displayed.	● Disc loaded upside-down. ● Disc dirty. ● Non-standard disc loaded.	● Reload disc. ● Clean disc. ● Replace with standard disc.	21 27 21
	Operation not performed when buttons pressed, or playback stops in middle of track.	● Disc loaded upside-down. ● Foreign object in disc holder. ● Disc dirty. ● Disc scratched.	● Reload disc. ● Remove disc and remove foreign object. ● Clean disc. ● Replace with non-scratched disc.	21 21 27 -
	Sound skips.	● Dust, fingerprints, or spittle on disc. ● Disc scratched. ● Player set in shaky, unstable place.	● Clean disc. ● Replace with non-scratched disc. ● Set player in stable place.	27 - -
	Buzzing noise mixed in with CD sound.	● Signals coming over power cord are modulated by power source frequency.	● Plug in cord in opposite direction.	5

Normal operation may not be possible if there is dirt or other substances on the surface of the internal objective lens or sensor.
These parts must be cleaned periodically depending on the place of installation.
For details, contact your store of purchase.

Avoid using ultrasonic humidifiers nearby.
If ultrasonic humidifiers are used nearby, the calcium, etc., included in the water may be scattered into the air, causing white dust to accumulate on the surface of the objective lens or sensor, resulting in improper operation.

Dew (Condensation) Phenomenon

Dew (water droplets) may form on the lens of the internal optical system or on the disc, or on the rotating parts of the tape deck in situations such as the following:

- Soon after a heater is put on.
- When the set is placed in a steamy or damp room.
- When the set is moved from a cold place to a warm room.

When Condensation Forms

The signals of the disc may not be read and this product will not operate properly. To remove the condensation, take out the disc and switch on the power. The condensation will evaporate within 1 hour and the set will operate normally.

This system consists of precision components using microprocessors. Avoid using it in places where there is much external noise. If used in such places, the system may not operate properly, but this is not a problem with the system. If the system does not operate properly, try performing the desired operation again.

When you bring the cassette deck (UDR-65) or the CD player (UCD-65) in for repair, bring the receiver (UDRA-65) at the same time.

RECEIVER SECTION

BLOCK, LEVEL DIAGRAM

TUNER SECTION

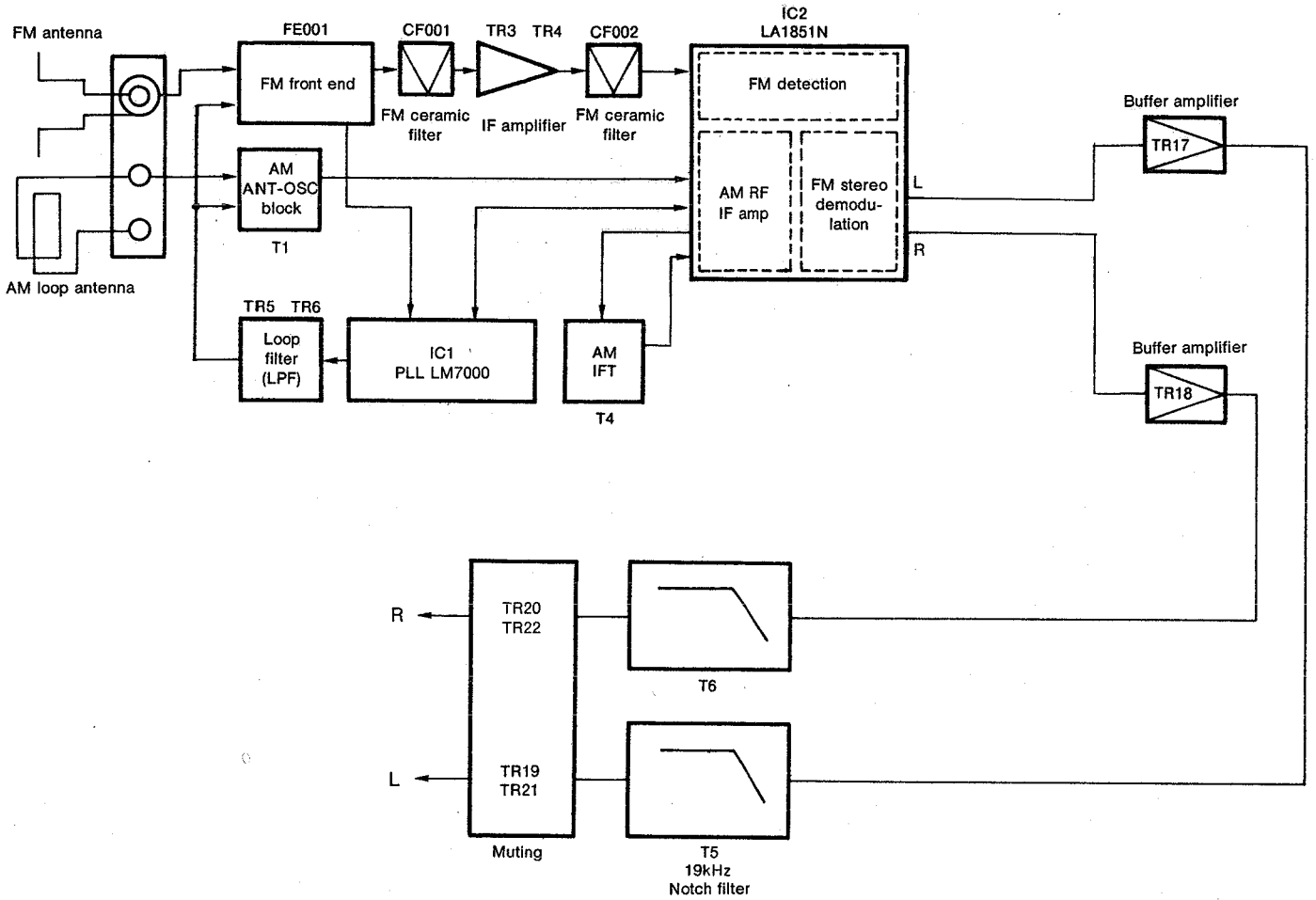

AMP. SECTION

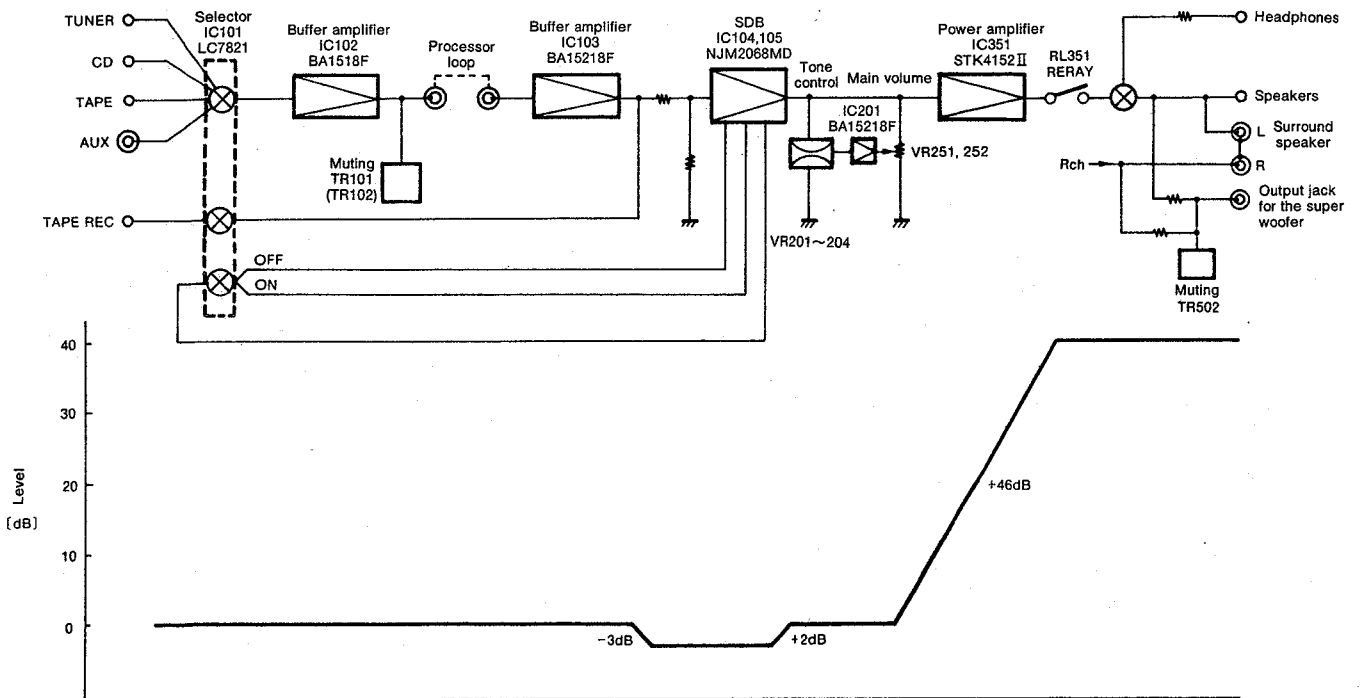

RECEIVER SECTION

DISASSEMBLY PROCEDURES

(Follow these procedures in reverse order to reassemble.)

1. Removing the Top Cover and the Front Panel

- ① Remove the six screws that fasten the top cover.
- ② The top cover is held in the rib of the front panel. Caution is required when taking off the top cover since if it is not removed in the direction of the arrow (vertically), the rib might be bent.

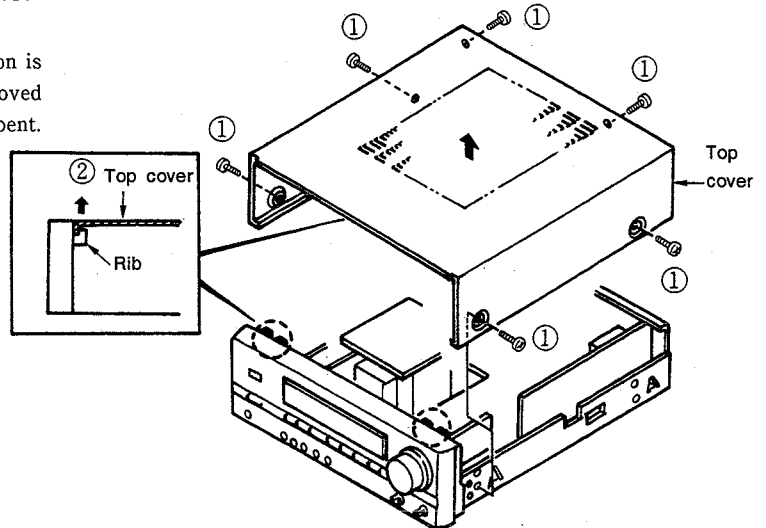

- ③ Remove the two screws that fasten the front panel.
- ④ While releasing the hooks of the front panel from the chassis, remove the front panel in the direction of the arrow.

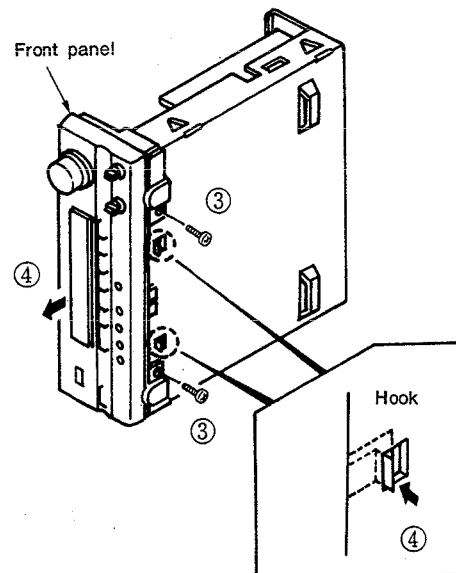

2. Removing the Various Units

Main Volume Unit (2U-2554B-3)

- ① Remove the main volume control assembly in the direction of the arrow, then remove the nut that is attached to the main volume unit.
- ② Remove the four screws which fasten the LCD assembly.

Display Unit (2U-2554B-2)

- ③ Remove the eight screws which fasten the display unit.
- ④ Disconnect the connectors which are connected to the main unit from the various unit.

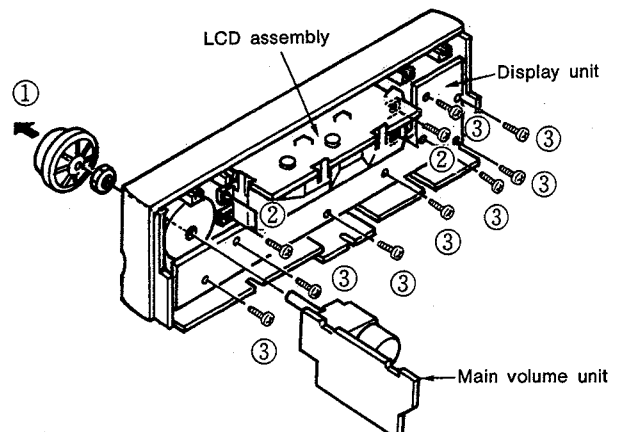

RECEIVER SECTION

3. Removing the Rear Panel

- ⑤ Remove the cord bush from the rear panel.
- ⑥ Remove the shorting pin.
- ⑦ Remove the ten screws which fasten the rear panel.
- ⑧ Remove the rear panel in the direction of the arrow.

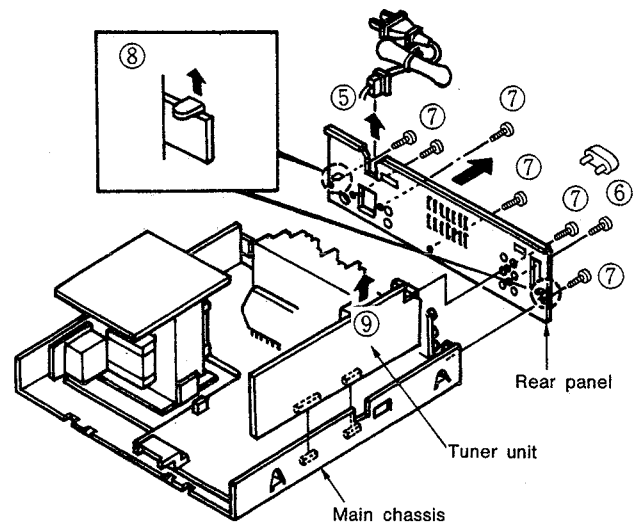

Tuner Unit (2U-2555B)

- ⑨ Pull off the tuner unit from the connector in the direction of the arrow.

Tuner Unit (2U-2555B)

- ⑨ Pull off the tuner unit from the connector in the direction of the arrow.

Main Unit (2U-2554B-1)

- ⑩ Remove the three screws which fasten the main unit.
- ⑪ Remove the three screws which fasten the radiator and main chassis.
- ⑫ While holding the two P.W.B. holders with pliers, remove the main unit in the direction of the arrow.

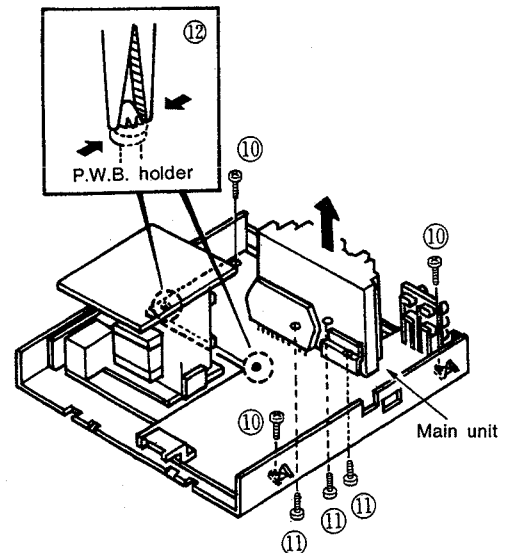

RECEIVER SECTION

ADJUSTMENTS

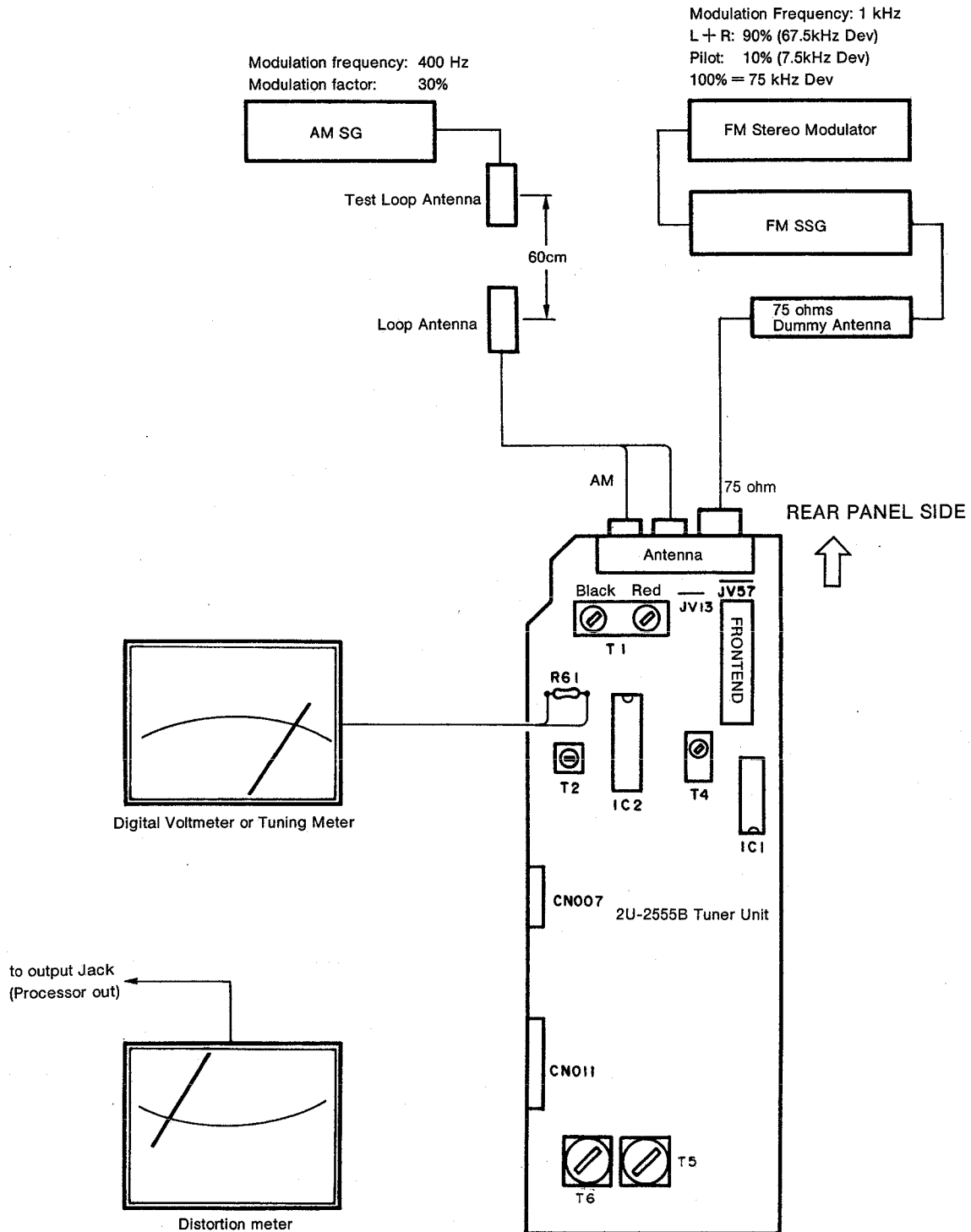

RECEIVER SECTION

1. FM adjustment (BAND button: FM, MONO/ST button: STEREO)

Step	Adjustment item	Tuning point (Channel setting)	Input				Output		Adjustment location	Setting value	Notes	
			Measuring instrument	Frequency	Input level	Modulation	Connection location	Measuring instrument				Connection location
1	FM DC balance	98.00MHz	FM S.G.	98.00MHz	60dB μ	1kHz 75kHz DEV	FM antenna terminal	Digital volt	R61	T-2	0 \pm 50 mV or tuning meter center	Perform with monaural modulation signal

2. AM adjustment (BAND button: AM)

1	IF	Clear frequency (without a broadcast)	AM IF sweep	-	Level at which AGC is not applied	-	AM antenna terminal	Oscilloscope	Output jack (Processor out)	T-4	Waveform maximum and symmetry	
2	Band edge	522kHz 1611kHz	-	-	-	-	-	Digital voltmeter	\oplus JV13 \ominus JV57	T-1 Black	1.2V	
3	Tracking	603kHz	AM S.G.	603kHz	Level at which AGC is not applied	400Hz 30%	Loop antenna	VTVM	Output terminal (Processor out)	T-1 Red	Maximum output	No place to adjust

Front End
Part No.: 216 0093 007

No.	Name	No.	Name
1	IF.OUT	5	Vcc
2	GND	6	GND
3	F.OUT	7	GND
4	VT	8	ANT

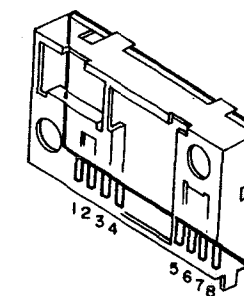

2U-2555B TUNER UNIT ASS'Y (Component Side)

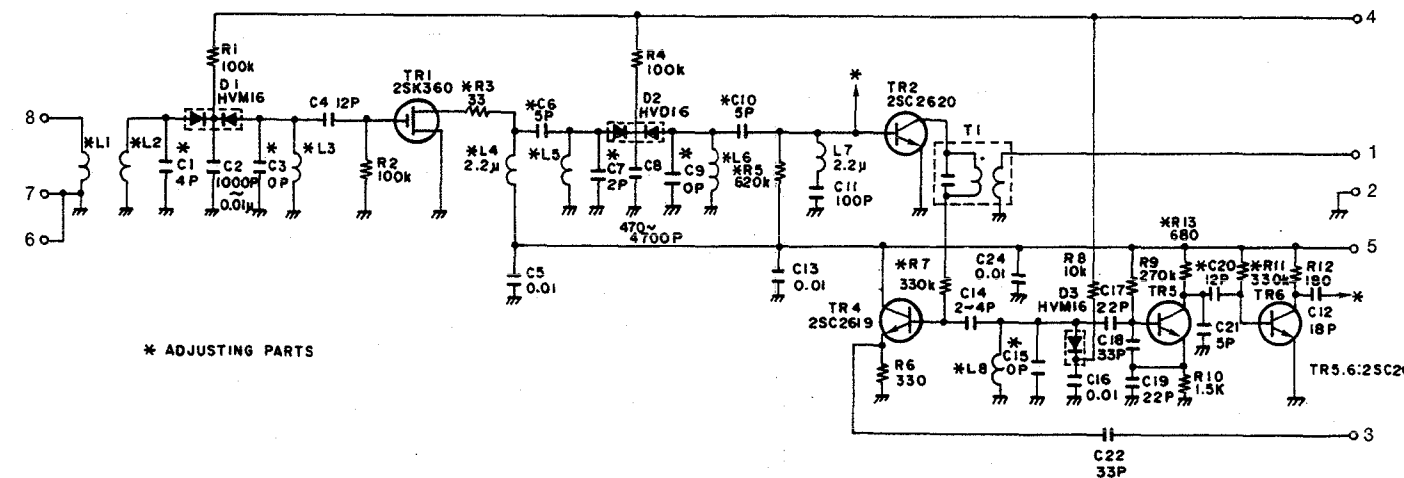
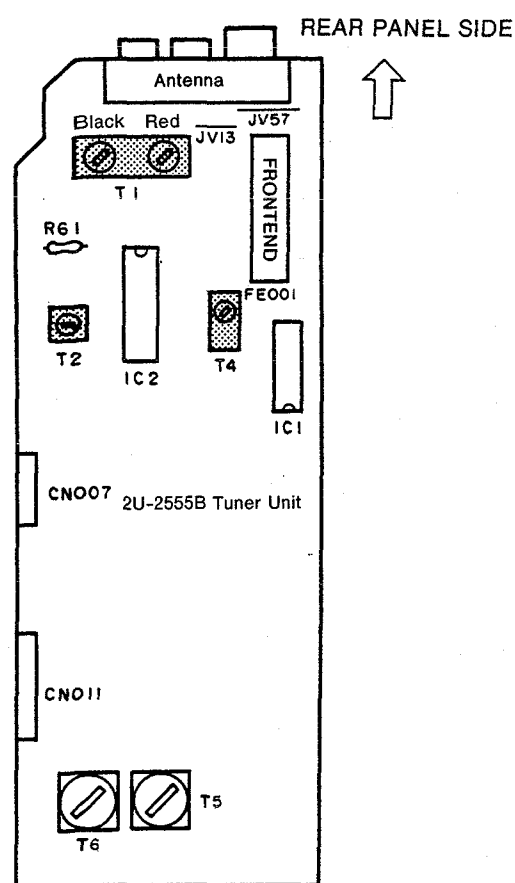

- Note
1. Terminal Number Refer to Overall Appearance
 2. Receiving Frequency 87.5~108MHz
 3. Input Impedance ⑧~⑦ 75 ohm
 4. Output Impedance 300 ohm
 5. Supply Voltage 12V
 6. Tuning Voltage 1.2~8.2V

RECEIVER SECTION

IC's
LM7000 (IC001)

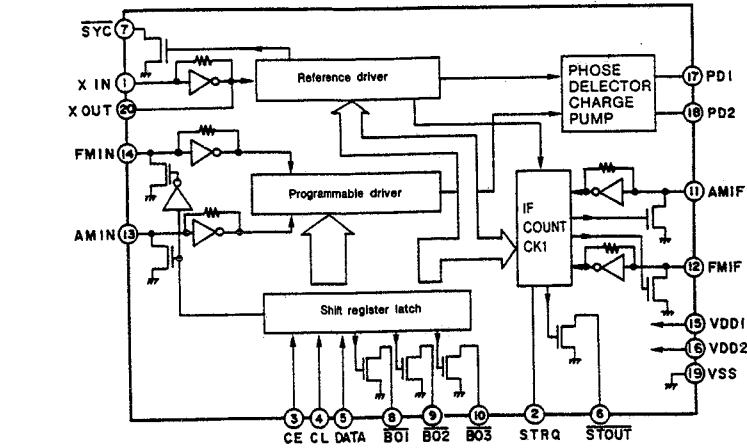
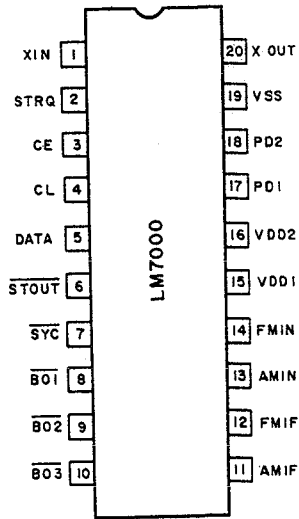
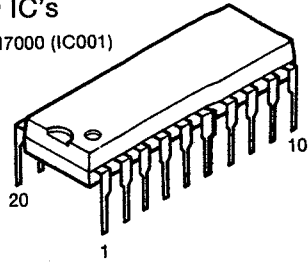

Pin Description

- SYC : Clock (400 kHz) for the controller
- XIN, XOUT : X'tal oscillator (7.2 MHz) with built-in feedback resistor
- FM IN, AM IN : Local oscillator signal input
- CE, CL, DATA : Data input
- B01, B02, B03 : Band data output. B01 can be set as the time base output (8 Hz).
- STRQ : IF counter request input
- STOUT : Auto research stop signal output
- VDD1, VDD2, VSS : Power supply (VDD2 is a back-up power supply)
- AMIF, FMIF : IF signal input
- PD1, PD2 : Charge pump output

LA1851N (IC002)

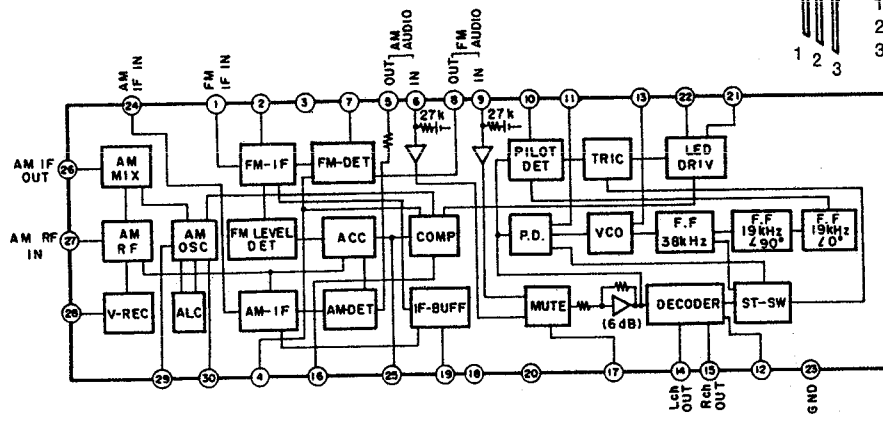
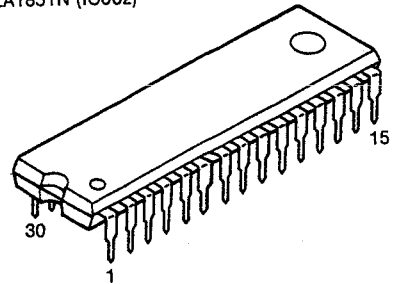

PST529C (IC701)

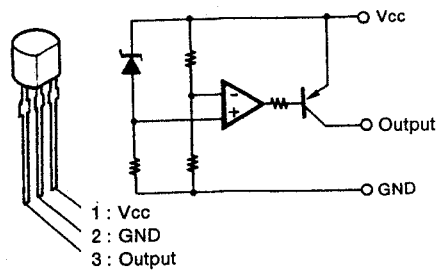

SEMICONDUCTORS

NJM7806FA (S) (IC688)
NJM78M12FA (S) (IC605)

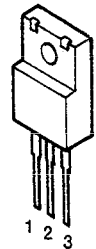

- 1: Input
- 2: GND
- 3: Output

LB1639 (IC251)

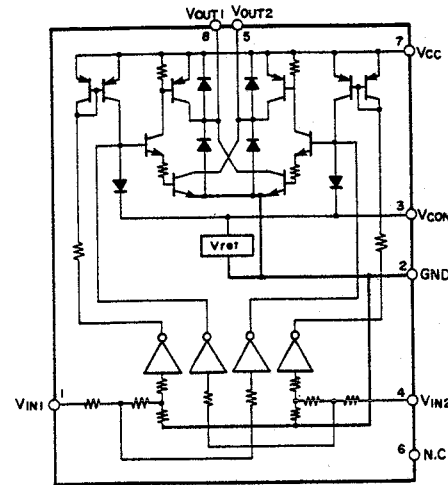
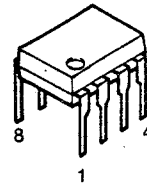

LC7821 (IC101)

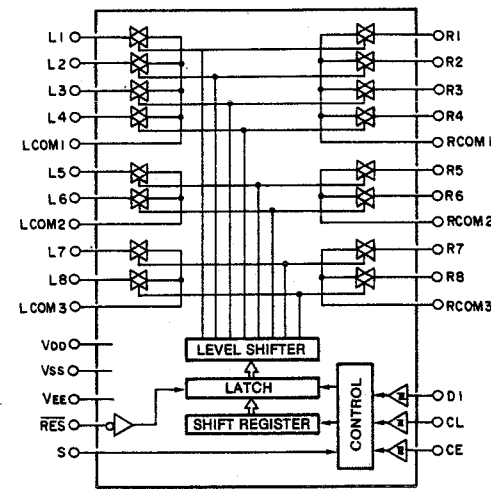
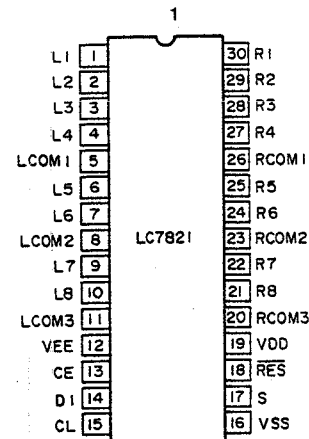
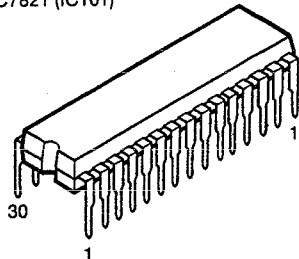

STK4152 II (IC351)

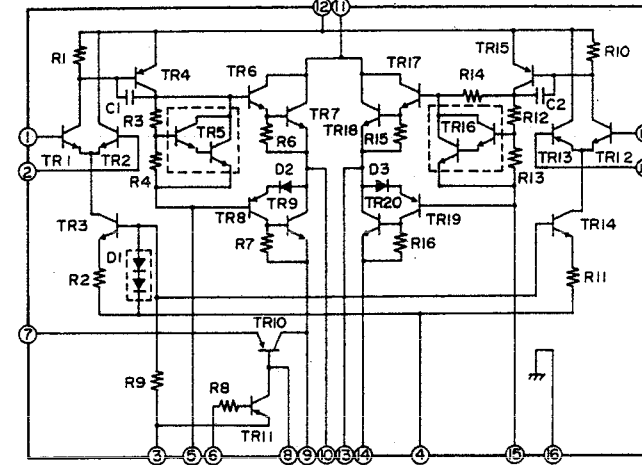
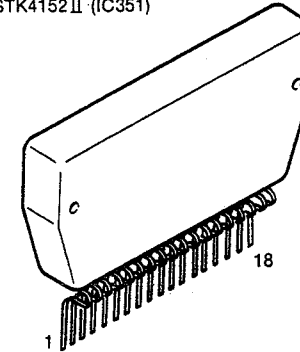

BA15218F (IC102, 103, 201)
NJM2068MD (IC104, 105)

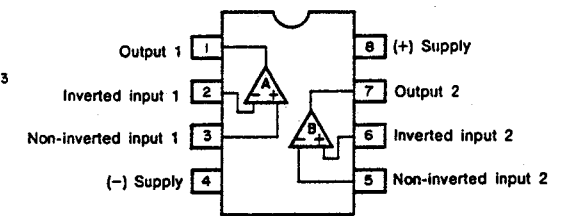
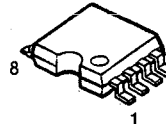

M5230L (IC651)

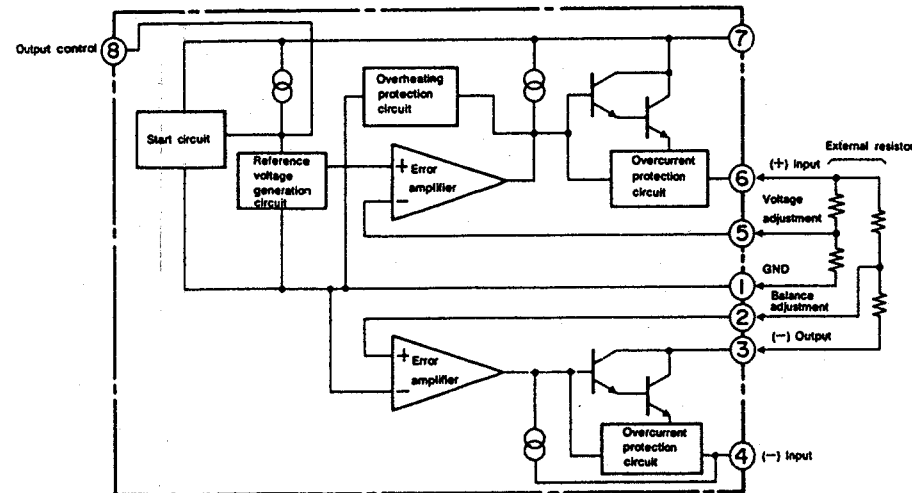
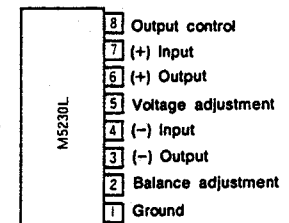
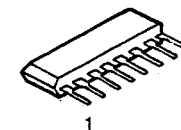

RECEIVER SECTION

● Transistors

2SC1740S (S)



B (Base)
C (Collector)
E (Emitter)

2SA1488 (Y)/(G)
2SC3851 (Y)/(G)
2SD1913



E (Emitter)
C (Collector)
B (Base)

2SC2410S



B (Base)
C (Collector)
E (Emitter)

2SK381 (C)



D (Drain)
G (Gate)
S (Source)

2SA1037K (S/R)
2SC2412K (S)

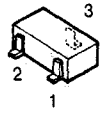

1 : Emitter
2 : Base
3 : Collector

DTA144ES PNP Type
DTC114ES } NPN Type
DTC144ES

PNP Type
DTA ES Series

NPN Type
DTC ES Series



B (Base)
C (Collector)
E (Emitter)

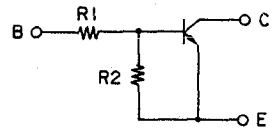
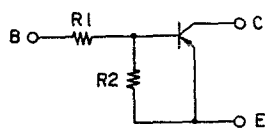

	R1	R2
DTA144ES	47k ohm	47k ohm

	R1	R2
DTC114ES	47k ohm	47k ohm
DTC144ES	10k ohm	10k ohm

DTA114EK } PNP Type
DTA144EK }
DTC114EK } NPN Type
DTC144EK }
DTC314TK }

PNP Type
DTA EK Series

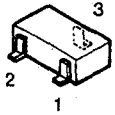

1 : Emitter
2 : Base
3 : Collector

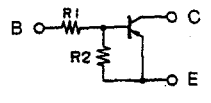

	R1	R2
DTA114EK	10k ohm	10k ohm
DTA144EK	47k ohm	47k ohm

NPN Type
DTC EK Series

NPN Type
DTC TK Series

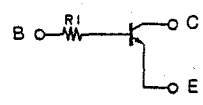
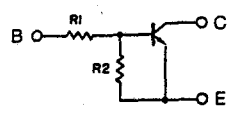

	R1	R2
DTC114EK	10k ohm	10k ohm
DTC144EK	47k ohm	47k ohm

	R1
DTC314TK	10k ohm

RECEIVER SECTION

● Diodes

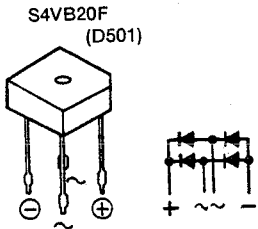
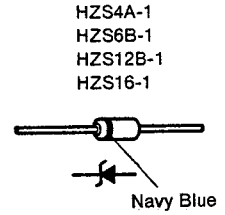
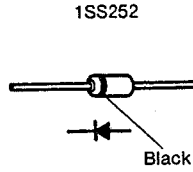
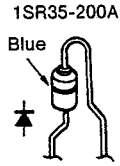
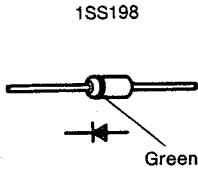
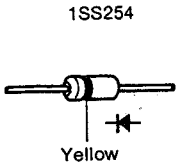

● IC Protector

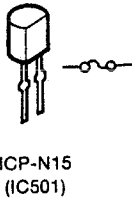

● Infrared Remote Control Sensor

SBX1610-52 (IC703)
Part No.: 499 0150 008

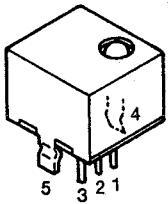

- 1. Vcc
- 2. Output
- 3. GND
- 4. Case fin
- 5. Case fin

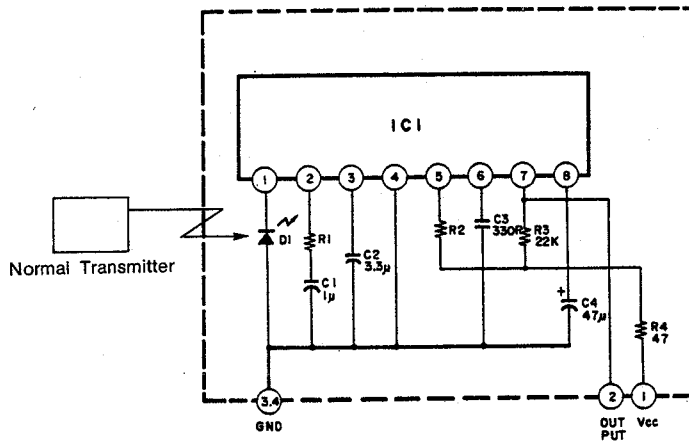

* This unit is wholly used in the receiver section.

- IC1: CX20106A chip
- D1: PIN photodiode chip
- C1,C2,C4: Aluminum electrolytic capacitor
- C3: Ceramic SL characteristics, ±5%
- R1: Carbon film resistor for gain adjustment
- R2: Carbon film resistor for fo adjustment (Use±1%)
- R (other than above): ±5%

● LCD Ass'y
(Part No.: 393 6001 002)

Schematic Diagram

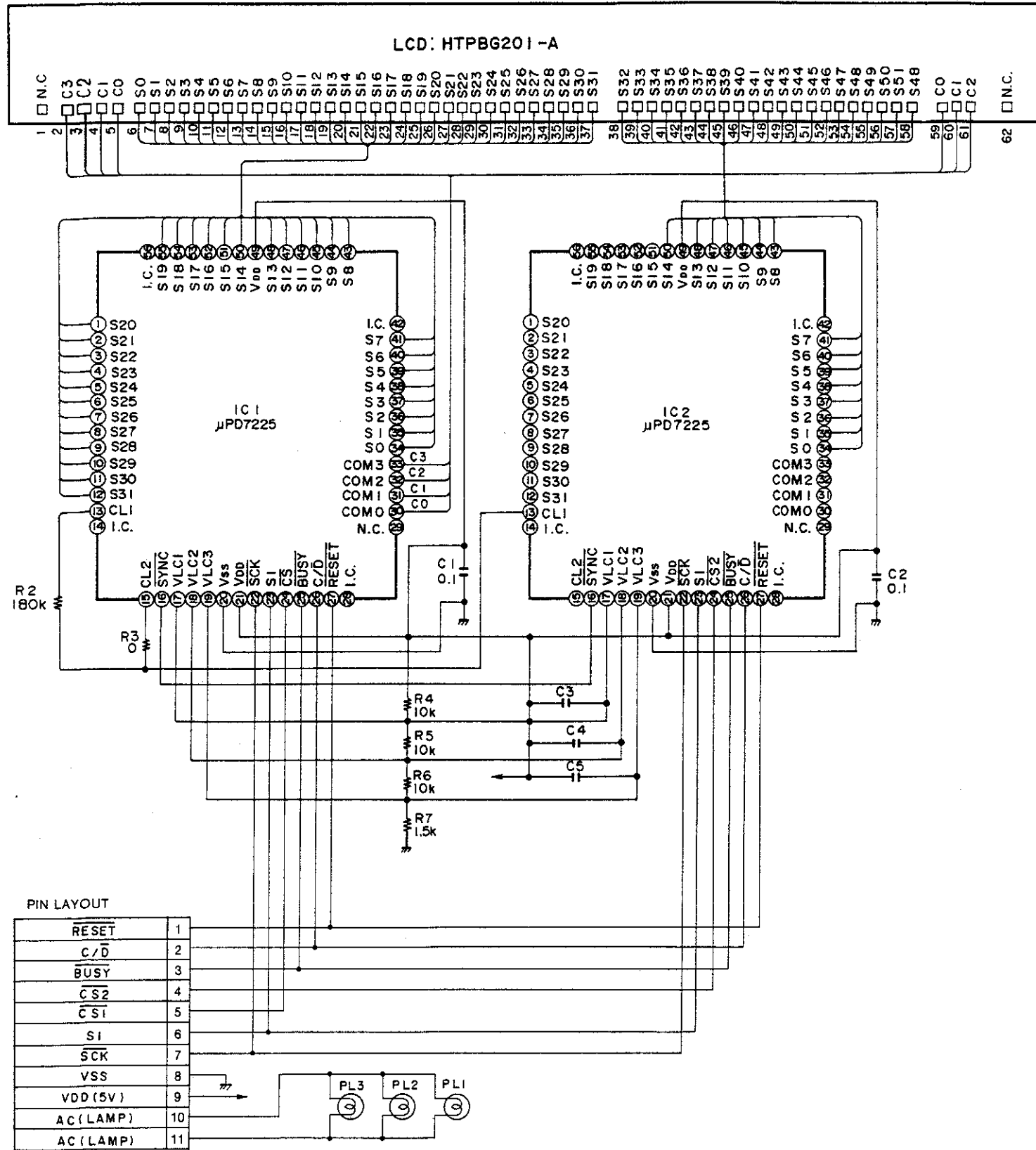

RECEIVER SECTION

Wiring Diagram

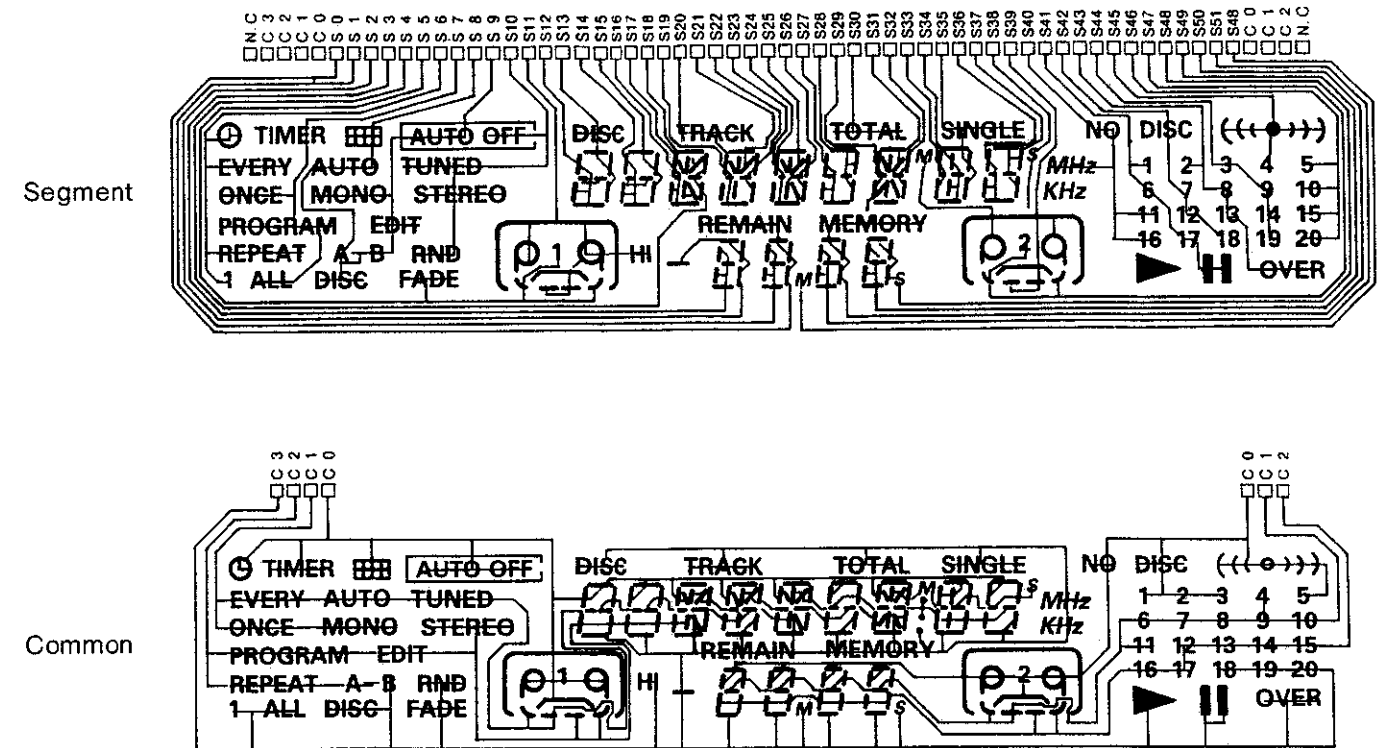

Connections

PIN No.	SYMBOL
1	RESET
2	C/D
3	BUSY
4	CS2
5	CS1
6	SI
7	SCK
8	VSS
9	VDD (5V)
10	AC (LAMP)
11	AC (LAMP)

Lamp characteristics
(Part number: 393 0106 000)

Initial Characteristics					
Test voltage (V)	Current (mA)	Power (W)	Beam Lm	Efficiency	Rated service life
5 V	115 mA	0.6 W	(2.5 Lm)	4.2 Lm/W	10,000 h

Parts List

Part No.	Part Name	Quantity	Item
①	LCD	1	5V, 1/4D, 1/3B
②	PWB	1	CEM-3 board thickness 1.6t
③	Diffusion board	1	Acrylic board; board thickness 2.0t
④	Lamp housing	1	Polycarbonate
⑤	Lamp	3	Rated at 5 V, 115 mA. Voltage used: 4.5 V AC.
⑥	LSI	2	NEC product μ PD7225GB
⑦	Connector	1	Nippon Atchaku Tanshi product S128-PH-K-S
-	Resistors	6	R2 = 180k, R3 = 0, R4, R5, R6 = 10k, R7 = 1.5k
-	Capacitors	2	C1, C2 = 0.1 μF

RECEIVER SECTION

MICROPROCESSOR DOCUMENTATION

HD643378A11F Part No.: 262 1821 103

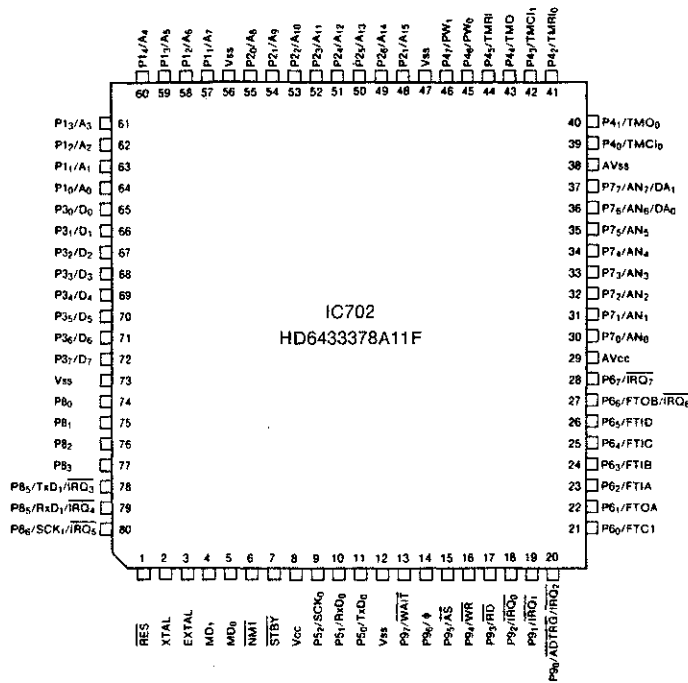
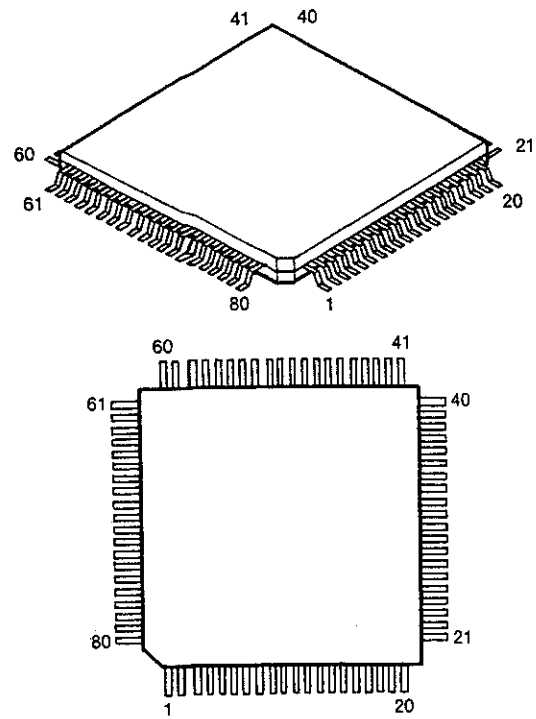

1. Overview

The functions of this microcomputer are made up of the following four pillars.

a. Tuner Functions

- These functions perform the required control for the reception of FM and AM broadcasts.

b. Auto Functions

- Positioned at the heart of the system stereo, the auto functions perform serial communications with other components (such as the deck, CD, and amplifier) to provide overall control.
- These functions decode the signals from the remote control and send them to each component of the system.

c. Timer Functions

- Counts the clock of the 24-hour display.
- Provides 3 types of timer operation: Everyday, once and sleep.

d. CD Display Function

- Provides the CD operation displays.

Note 1: When buttons "STANDBY" and "MEMORY" of the wiring diagram are pressed simultaneously and the power cord is inserted into the power outlet, the frequencies used for the tracking adjustment will automatically be registered in the preset memory as indicated below. Use this information for tuning and other procedures.

	P1	P2	P3	P4	P5	P6	P7	P8	P9	P10
AM (kHz)	522	603	999	1,098	1,404	1,611	522	522	522	522
	P11	P12	P13	P14	P15	P16	P17	P18	P19	P20
FM (MHz)	87.50	89.00	98.00	100.10	108.00	87.50	87.50	87.50	87.50	87.50
	P21	P22	P23	P24	P25	P26	P27	P28	P29	P30
AM (kHz)	522	522	522	522	522	522	522	522	522	522

*P7 through P10 and P21 through P30 are AM 522 kHz, and P16 through P20 are FM 87.50 MHz.

Note 2: Depressing both the MEMORY and BAND buttons while plugging the power cord into the power outlet serves to initialize the current time setting and the contents of the timer and preset memory.

2. Receiving Band Table

Band	Receiving frequency	Local oscillator frequency	IF frequency	Frequency division ratio	Comparison frequency	Step frequency	Other
FM	87.50~108.00 MHz	98.20~118.70 MHz	10.7 MHz	1/2	25 kHz	100 kHz	STEREO
AM	522~1611 kHz	972~2061 kHz	450 kHz	-	9 kHz	9 kHz	

3. Signals sent to the LM7000 Programmable Divider

- Signals to the programmable divider are sent from 3 sources: CE OUT, CLOCK OUT, and DATA OUT.
- The programmable divider takes in DATA at CLOCK \downarrow , when CE equals 1.
- The data is a 24-bit serial signal which is taken in to the programmable divider from the LSB. (At the AM setting, D₀ through D₃ are ignored, so that D₄ becomes the LSB.)
- The data is made up of the number of frequency divisions data, the band data, and the comparison frequency data. (See diagram below.)

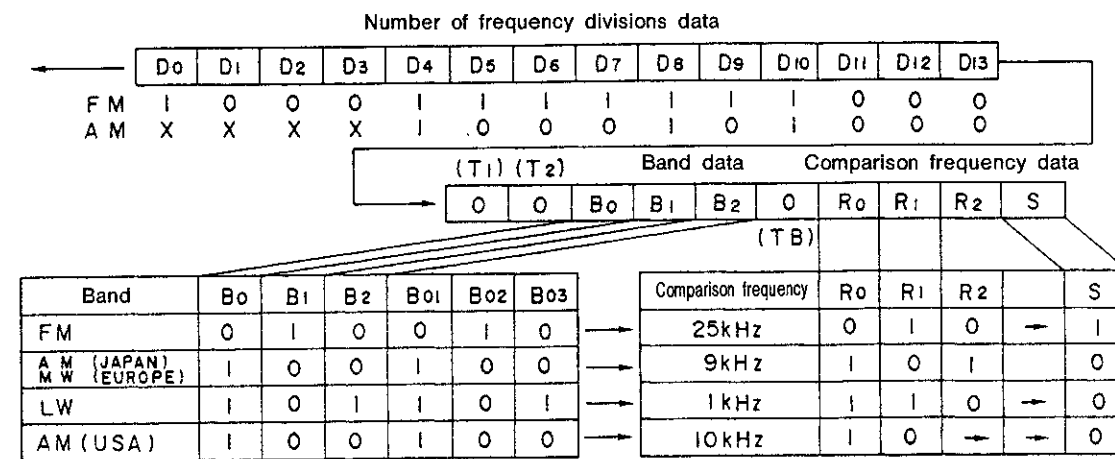

e. Timing for sending

a = 2.5 μsec

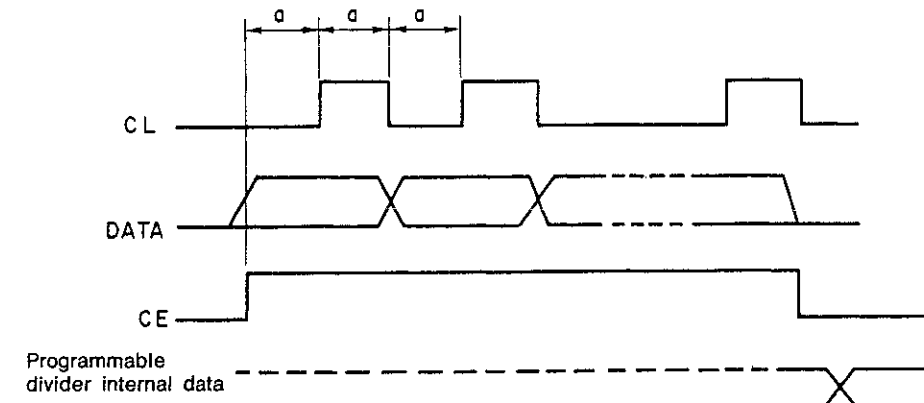

RECEIVER SECTION

Pin Description

Pin No.	Port Name	Function Name	N	A	Function
1	RES	CPU. RESET	H	L	Hard reset
2	XTAL	X'TAL	-	-	20 MHz (Oscillator connection)
3	EXTAL	X'TAL	-	-	20 MHz (Oscillator connection)
4	MD1	MODE1	H	H	VCC connection
5	MD0	MODE0	H	H	VCC connection
6	NMI	SERIAL SIG IN	H	L	Serial communications input
7	STBY	STANDBY	H	L	HARD STANDBY input
8	VCC	VCC	-	-	VCC connection
9	P52/SCK0	DR SCK IN	L	H	NC
10	P51/RXD0	DR SI IN	L	H	UDR display CLOCK input
11	P50/TXD0	-	-	-	UDR display input
12	VSS	VSS	-	-	N.C. DATA
13	P97/WAIT	SERIAL SIG OUT	H	L	Serial communications output
14	P96/O	O/2 OUT	L	H	System clock out (10 MHz)
15	P95	AVC CHECK2 IN	L	H	AVC control input 2
16	P94	AVC CHECK1 IN	L	H	AVC control input 1
17	P93	PROTECT IN	L	H	Amp. protect input
18	P92/IRQ0	SERIAL SIG IN	L	H	Serial communications input
19	P91/IRQ1	50/60	H	L	50/60 Hz input (clock)
20	P90/ADTRG/IRQ2	REMOCON IN	H	L	Remote control input
21	P60/FTCI	S.FUNC MUTE OUT	H	L	FUNCTION MUTE output (LOW → MUTE ON)
22	P61/FTOA	S.CE	L	H	LC7821-L CE output
23	P62/FTIA	S.DATA	L	H	LC7821-L data output
24	P63/FTIB	S.CLOCK	L	H	LC7821-L clock output
25	P64/FTIC	PLL CE	H	L	PLL CE output
26	P65/FTID	PLL DATA	H	L	PLL DATA output
27	P66/FTOB/IRQ6	PLL ST REQ	H	L	PLL REQUEST output
28	P67/IRQ7	PLL CLK	H	L	PLL CLOCK output
29	AVCC	AVCC	-	-	VCC connection
30	P70/AN0	KR0	L	H	Key return 0
31	P71/AN1	KR1	L	H	Key return 1
32	P72/AN2	KR2	L	H	Key return 2
33	P73/AN3	KR3	L	H	Key return 3
34	P74/AN4	KR4	L	H	Key return 4
35	P75/AN5	KR5	L	H	Key return 5
36	P76/AN6/DA0	KR6	L	H	Key return 6
37	P77/AN7/DA1	KR7	L	H	Key return 7
38	AVSS	AVSS	-	-	Ground connection
39	P40/TMC10	KS0	L	H	Key strobe 0
40	P41/TMO0	KS1	L	H	Key strobe 1
41	P42/TMR10	KS2	L	H	Key strobe 2
42	P43/TMC11	KS3	L	H	Key strobe 3
43	P44/TMO1	KS4	L	H	Key strobe 4
44	P45/TMR11	KS5	L	H	Key strobe 5
45	P46/PW0	KS6	L	H	Key strobe 6
46	P47/PW1	KS7	L	H	Key strobe 7
47	VCC	VCC	-	-	VCC connection
48	P27	-	-	-	N.C.
49	P26	LCD BUSY	H	L	μPD7225 BUSY signal input
50	P25	LCD C/D	-	-	Itrol output H: Command transfer L: Data transfer
51	P24	LCD RESET	H	L	μPD7225 reset signal input
52	P23	LCD CS2	H	L	μPD7225-2 chip select output
53	P22	LCD CS1	H	L	μPD7225-1 chip select output
54	P21	LCD SI	H	L	μPD7225 serial data output
55	P20	LCD SCK	H	L	μPD7225 serial clock output
56	VSS	VSS	-	-	Ground connection
57	P17	DIMMER OUT	L	H	Power on → High
58	P16	SDB OUT	L	H	SDB in → High (Not using this device)
59	P15	SURR OUT	L	H	Surround on → High
60	P14	20dB MUTE OUT	L	H	20 dB on → High (Not using this device)
61	P13	PROCESSOR MUTE	L	H	PROCESSOR MUTE (LOW → MUTE ON)
62	P12	VOL PASS OUT	L	H	Vol. pass on → High (Not using this device)
63	P11	AVC OUT	L	H	Func. AVC → High (Not using this device)
64	P10	PRE OUT	L	H	Preout on → High (Not using this device)
65	P30	VOLUME UP OUT	H	L	Vol. up → High
66	P31	VOLUME DOWN OUT	H	L	Vol. down → High
67	P32	POWER OFF OUT	L	H	After power has been on for 5 s → High (Not using this device)
68	P33	RELAY OUT	L	H	Power on → High (Audio power supply up built into microprocessor)
69	P34	SIGNAL IN	H	L	Tuner signal input (With pull-up built into microprocessor)
70	P35	TUNED IN	H	L	Tuner tuning signal input (With pull-up built into microprocessor)
71	P36	STEREO IN	H	L	Tuner stereo signal input (With pull-up built into microprocessor)
72	P37	STOP IN	H	L	Tuner stop signal input (With pull-up built into microprocessor)
73	VSS	VSS	-	-	Ground connection
74	P80	AM STEREO IN	H	L	AM stereo signal input
75	P81	TUNER MUTE OUT	H	L	Tuner mute output
76	P82	AUTO/MONO	L	H	Tuner auto → Low
77	P83	-	-	-	N.C.
78	P84/TXD1/IRQ3	-	-	-	N.C.
79	P85/RXD1/IRQ4	CD SI	L	H	VCD display DATA input
80	P86/SCK1/IRQ5	CD SCK	L	H	VCD display CLOCK input

Description of Key and Selection Switch Inputs [Items using this device]

Key	Function Name	Function
P40-P70	FREQ UP	* Increments the receive frequency in single steps in the tuner mode. Holding down the key for 0.5 seconds or longer causes the frequency to change continuously; releasing the key sets the auto tuning operation. Pressing the key again returns the function to the 1-step mode. * Increments the hours and minutes in single steps when set to the clock. Holding down the key for 0.5 seconds or longer causes the frequency to change continuously; releasing the key returns the function to the 1-step mode. * The timer mode operation is the same as that of the clock mode, but function switching is also performed.
P40-P71	FREQ DOWN	* Increments the receive frequency in single steps in the tuner mode. Holding down the key for 0.5 seconds or longer causes the frequency to change continuously; releasing the key sets the auto tuning operation. Pressing the key again returns the function to the 1-step mode. * Increments the hours and minutes in single steps when set to the clock. Holding down the key for 0.5 seconds or longer causes the frequency to change continuously; releasing the key returns the function to the 1-step mode. * The timer mode operation is the same as that of the clock mode, but function switching is also performed.
P40-P72	BAND	Operates in a cycle; switches between FM and AM.
P40-P73	MONO/STEREO	During FM reception, automatically switches the reception mode to monaural or stereo; or sets the mode to mono only.
P41-P70	CLOCK/DISPLAY	Sets the clock display or the frequency display.
P41-P71	ENTER/NEXT	Moves to the next item during a time setting or when setting the timer.
P41-P72	MEMORY	* When in the tuner mode, this function changes the currently received broadcast station to the memory presetting mode. The station can be registered with the number keys when "MEMORY" is flashing.
P41-P73	FUNCTION	Operates in a cycle and switches the function of the amplifier.
P42-P70	TIMER	Changes the mode to the timer setting mode. Two courses of setting selections are possible.
P42-P71	STANDBY	Determines the operation of the timer setting. The operation is set when the mark lights.
P42-P72	CLEAR	Clears the contents of the timer setting.
P42-P73	POWER	Switches power to the system on and off.
P43-P70	SURROUND	Operates in a cycle; switches surround on and off.
P43-P71	SDB	Operates in a cycle; switches SDB on and off.
P43-P72	-20dB MUTE	Selects whether the 20 dB muting is applied or not. Toggles the -20 dB MUTE OUT pin high and low.
P43-P73	DEMO	Changes the mode to the demo mode. This mode is automatically cancelled when the sequence is completed.
P44-P70	TAPE MONITOR	Selects the tape monitor. When TAPE MONI OUT1 is high, the tape monitor is on. When TAPE MONI OUT1 is low, the tape monitor is off.
P44-P71	DIMMER	Operates in a cycle; goes high when the dimmer is on, goes low when the dimmer is off.
P44-P72	SLEEP	Changes the mode to the sleep mode. The time setting becomes possible, upon another input.
P44-P73	PREOUT	Specifies an on/off setting of the preout function. Toggles PREOUT OUT high and low.
P40-P74	1	Number key, preset call, memory input key
P40-P75	6	Number key, preset call, memory input key
P40-P76	+10	Number key, preset call, memory input key
P40-P76	LW	Switches to the LW reception mode.
P41-P74	2	Number key, preset call, memory input key
P41-P75	7	Number key, preset call, memory input key
P41-P76	PRESET UP	Increments the preset number.
P41-P77		
P42-P74	3	Number key, preset call, memory input key
P42-P75	8	Number key, preset call, memory input key
P42-P76	PRESET DOWN	Decrements the preset number.
P42-P77		
P43-P74	4	Number key, preset call, memory input key
P43-P75	9	Number key, preset call, memory input key
P43-P76	AW (MW)	Switches to the AM (MW) reception mode.
P43-P77		
P44-P74	5	Number key, preset call, memory input key
P44-P75	10 (0)	Number key, preset call, memory input key
P44-P76	FM	Switches to the FM reception mode.
P44-P77		
P45-P70	USA	Sets the selection of reception frequency by location.
P45-P71	EUROPE	Sets the selection of reception frequency by location.
P45-P72	FREQ	Sets the selection of reception frequency by location.
P45-P73	FM WIDE	Switches the FM mode. Short → Wide is available. Open → FM Wide is not available.
P46-P70	OEM1 (DENON)	Open → "HELLO" display. Shorted → "DENON" display.
P46-P71	EX-PHONO	Selects the "AUX" and "PHONO" displays. (No serial data changes.) Open → "AUX" display. Shorted → "PHONO" display.
P46-P72	CD-RETRY	Selects a retry of the serial code at the time of executing EDIT or ARCS. Open → Retry is executed. Shorted → Retry is not executed.
P46-P73	X'TAL	Selects the crystal for sub clock adjustments. Open → Crystal is available; sub clock can be adjusted with timer off. Shorted → Crystal is not available; sub clock can be adjusted.
P47-P70	AM STEREO	Presence of AM stereo. Shorted: Available. Open: Not available.

RECEIVER SECTION

MICROPROCESSOR PERIPHERAL WIRING DIAGRAM

1 2 3 4 5 6 7 8

A

B

C

D

E

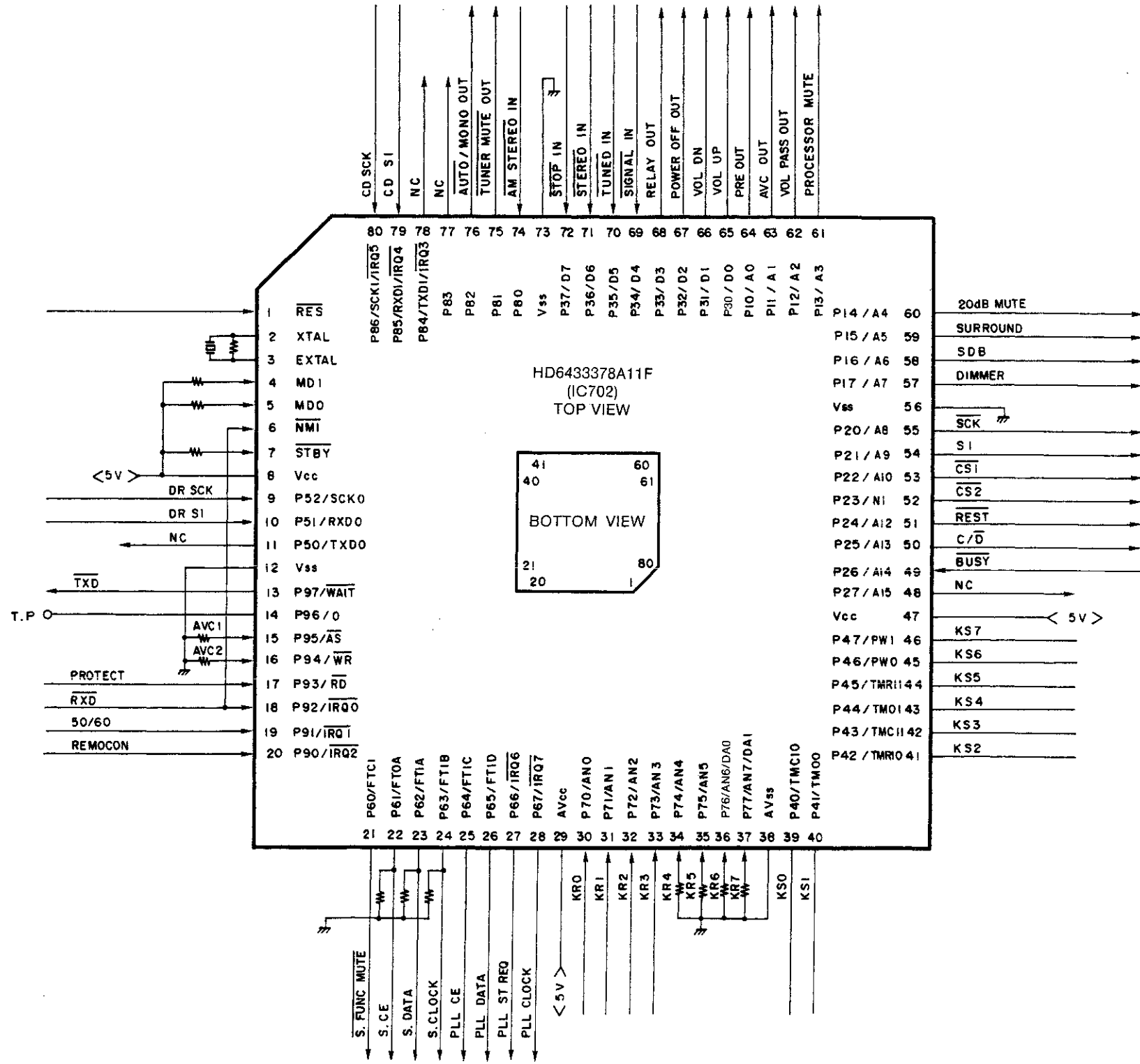

Matrix Definition [Item using this device]

	P40 (KS0)	P41 (KS1)	P42 (KS2)	P43 (KS3)	P44 (KS4)	P45 (KS5)	P46 (KS6)	P47 (KS7)
P70 (KR0)	FREQ UP	CLOCK DISPLAY	TIMER	SURROUND	TAPE MONI	USA	DEM (DENON)	AM STEREO
P71 (KR1)	FREQ DOWN	ENTER NEXT	STAND BY	SDB	DIMMER	EUROPE	EX PHONO	
P72 (KR2)	BAND	MEMORY	CLEAR	-20db MUTE	SLEEP	FREQ	CD-RETRY	
P73 (KR3)	MONO/STEREO	FUNCTION	POWER	DEMO	PREOUT	FM WIDE	XTAL	

P74 (KR4)	1	2	3	4	5			
P75 (KR5)	6	7	8	9	10 (D)			
P76 (KR6)	+10 AM/PM	PFESET UP	PRESET DOWN	AM (MW)	FM			
P77 (KR7)	LW							

Key matrix

Diodes matrix

PRINTED WIRING BOARD

RECEIVER SECTION

1 2 3 4 5 6 7 8

2U-2555B TUNER UNIT ASSY

Component Side

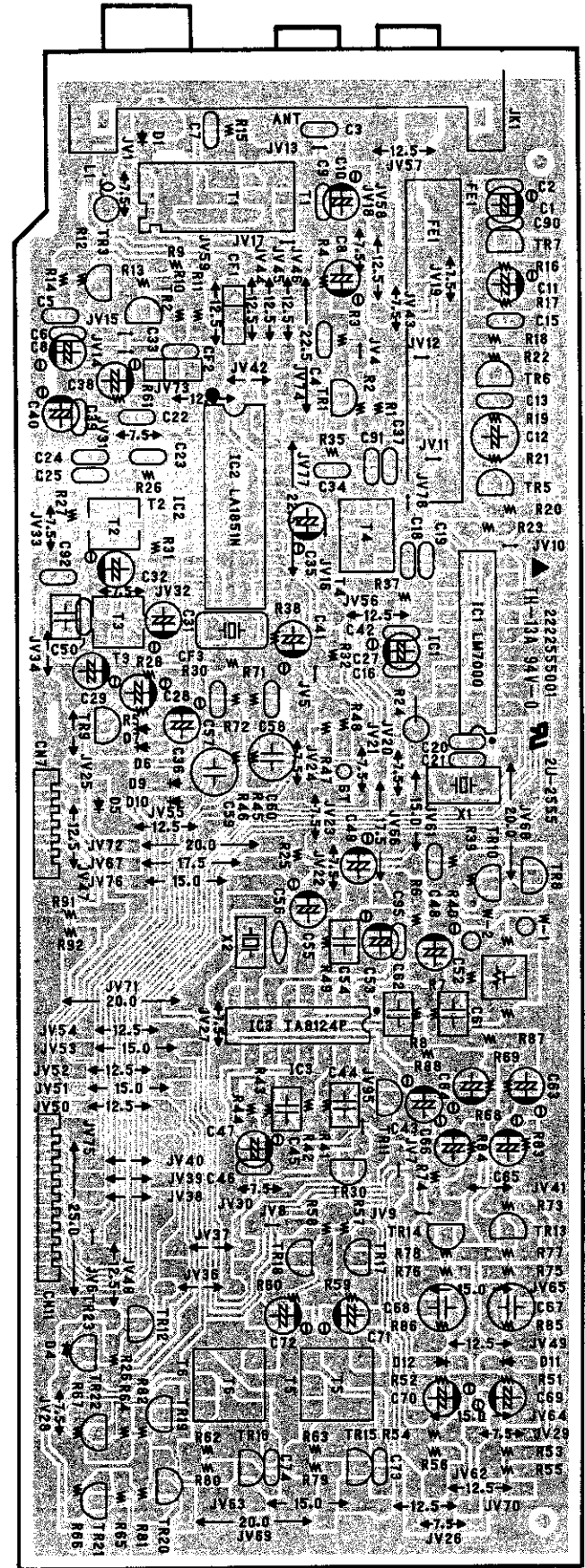

Pattern Side

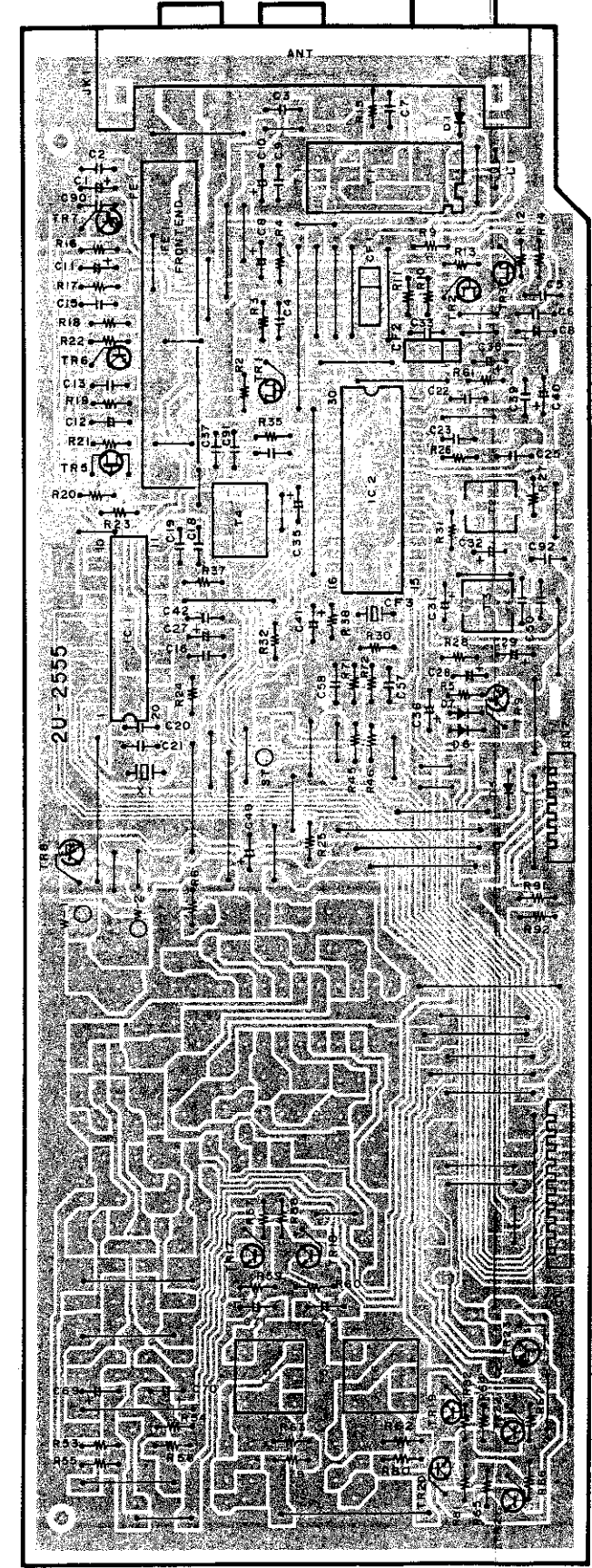

A

B

C

D

E

Component Side 2U-2554B MAIN UNIT ASS'Y

2U-2554B	
1	Main Unit
2	Display Unit
3	Main Volume Unit
4	Power Supply Unit (1)
5	Power Supply Unit (2)

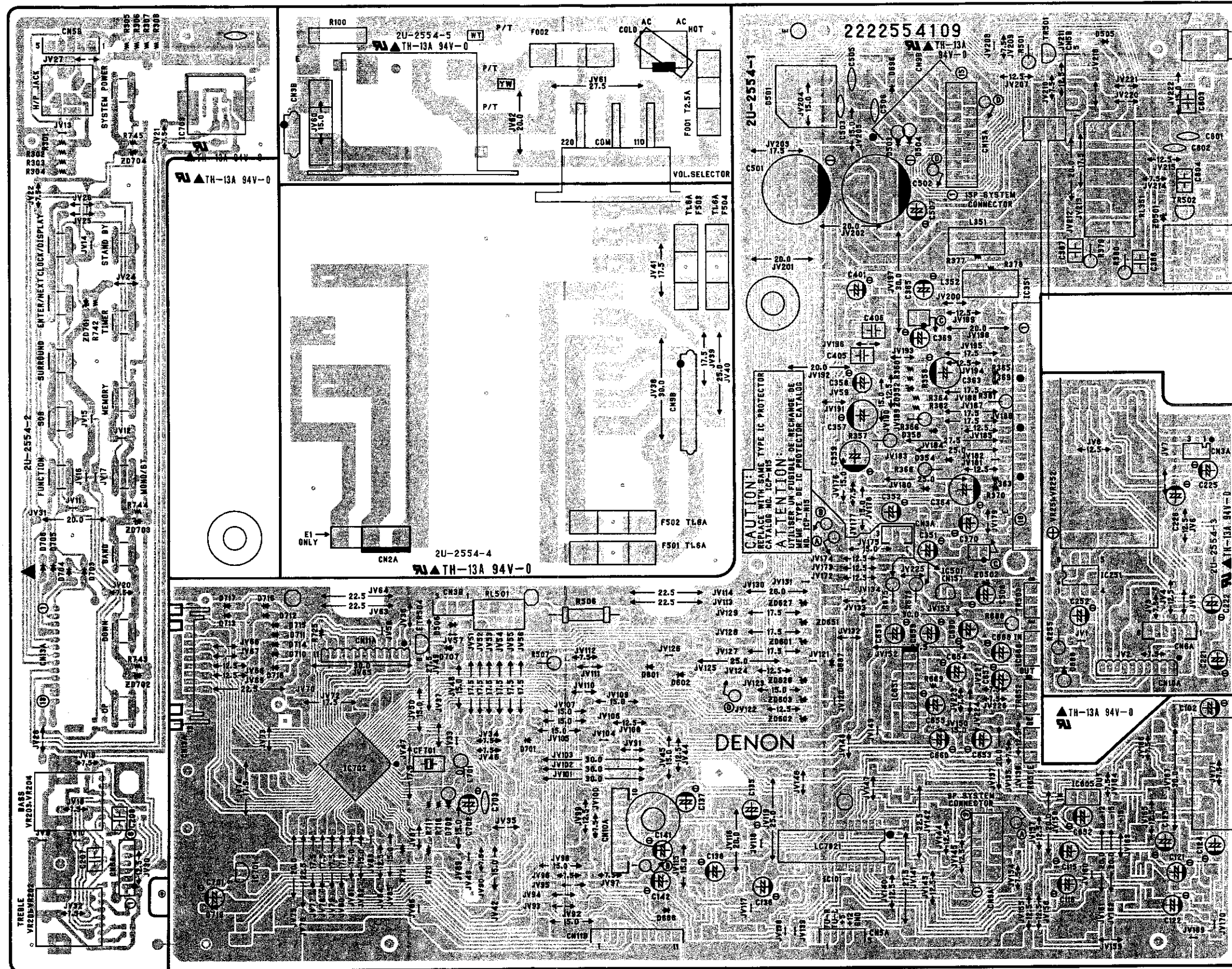

A
B
C
D
E

RECEIVER SECTION

1 2 3 4 5 6 7 8

Pattern Side

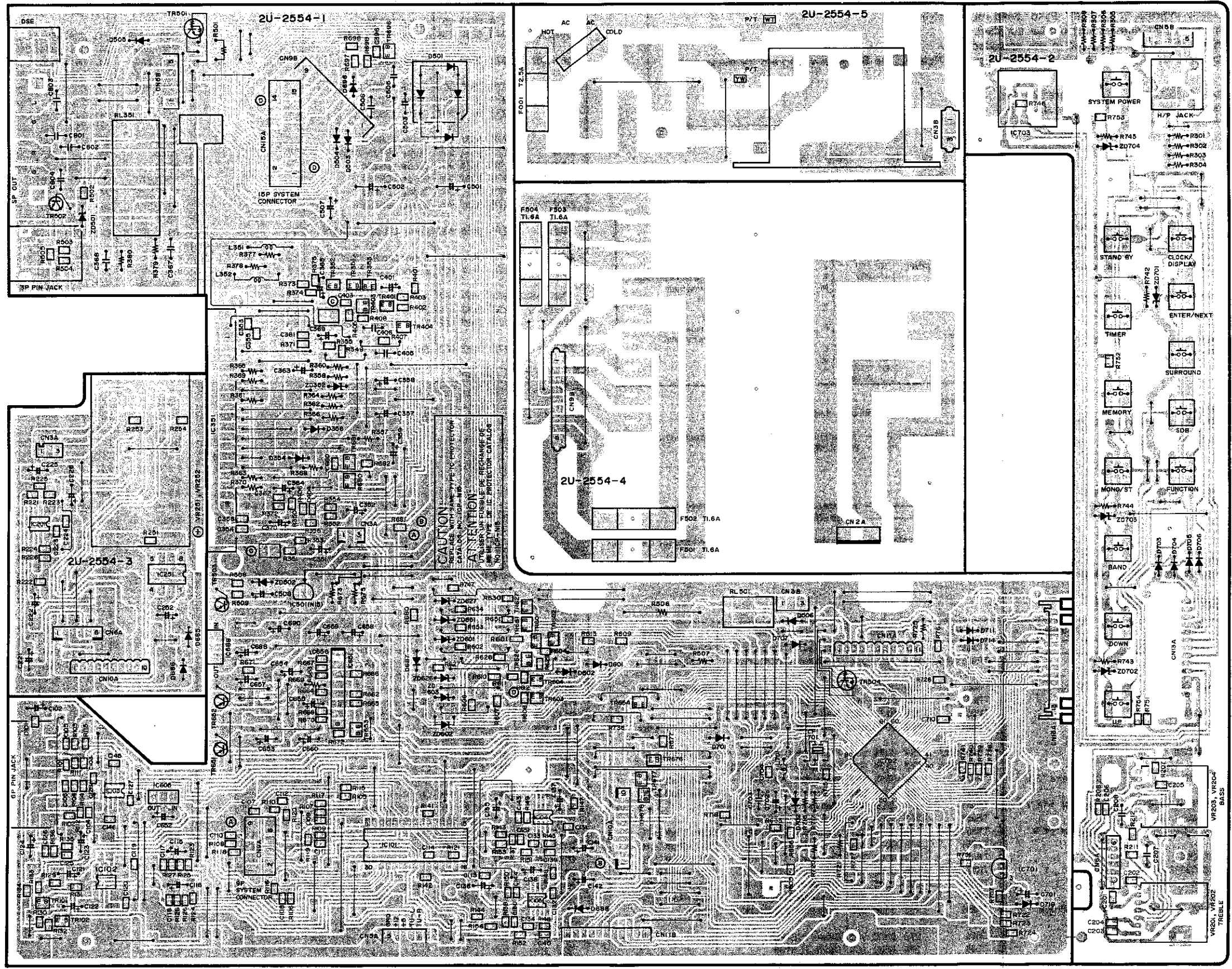

A

B

C

D

E

RECEIVER SECTION

NOTE ON PARTS LIST

- Part indicated with the mark "●" are not always in stock and possibly to take a long period of time for supplying, or in some case supplying of part may be refused.
- When ordering of part, clearly indicate "1" and "1" (i) to avoid mis-supplying.
- Ordering part without stating its part number can not be supplied.
- Part indicated with the mark "★" is not illustrated in the exploded view.
- Not including Carbon Film ±5%, 1/4W Type in the P.W. Board parts list. (Refer to the Schematic Diagram for those parts.)

WARNING:

Parts marked with this symbol Δ [hatched box] have critical characteristics. Use ONLY replacement parts recommended by the manufacturer.

Resistors

Table defining resistor codes: RN (Type), 14K (Shape and performance), 2E (Power), 182 (Resistance), G (Allowable error), FR (Others). Includes a list of abbreviations: RD (Carbon Film), RC (Composition), RS (Metallic oxide Film), RW (Winding), RN (Metal film), RK (Metal mixture), 2B (1/8W), 2E (1/4W), 2H (1/2W), 3A (1W), 3D (2W), 3F (3W), 3H (5W), F (±1%), G (±2%), J (±5%), K (±10%), M (±20%), P (±5%), Z (±20%), P (+100%), C (±0.25pF), D (±0.5pF), - (Others), P (Pulse-resistant type), NL (Low noise type), NB (Non-burning type), FR (Fuse-resistor), F (Lead wire forming).

Resistance: 1 8 2 ⇒ 1800 ohm = 1.8 kohm. Units: ohm. Capacity (electrolyte only): 2 2 R ⇒ 2200 µF. Units: µF.

Capacitors

Table defining capacitor codes: CE (Type), 04W (Shape and performance), 1H (Dielectric strength), 2R2 (Capacity), M (Allowable error), BP (Others). Includes a list of abbreviations: CE (Aluminum foil electrolyte), CA (Aluminum solid electrolyte), CS (Tantalum electrolyte), CQ (Film), CK (Ceramic), CC (Ceramic), CP (Oil), CM (Mica), CF (Metallized), CH (Metallized), OJ (6.3V), 1A (10V), 1C (16V), 1E (25V), 1V (35V), 1H (50V), 2A (100V), 2B (125V), 2C (160V), 2D (200V), 2E (250V), 2H (500V), 2J (630V), F (±1%), G (±2%), J (±5%), K (±10%), M (±20%), Z (+80%), P (-20%), C (±0.25pF), D (±0.5pF), - (Others), HS (High stability type), BP (Non-polar type), HR (Ripple-resistant type), DL (For charge and discharge frequency), U (UL part), C (CSA part), W (UL-CSA type), F (Lead wire forming).

* Capacity (except electrolyte): 2 R 2 ⇒ 2200pF = 2200 µF = 0.002 µF. Units: µF. When the dielectric strength is indicated in AC, "AC" is included after the dielectric strength value.

2U-2554B MAIN UNIT ASS'Y PARTS LIST

Main assembly parts list table with columns: Ref. No., Part No., Part Name, Remarks. Includes sub-sections for SEMICONDUCTORS GROUP and TRANSISTORS.

Large parts list table with columns: Ref. No., Part No., Part Name, Remarks. Includes a section for RESISTORS GROUP and various diodes, capacitors, and resistors.

RECEIVER SECTION

WIRING DIAGRAM

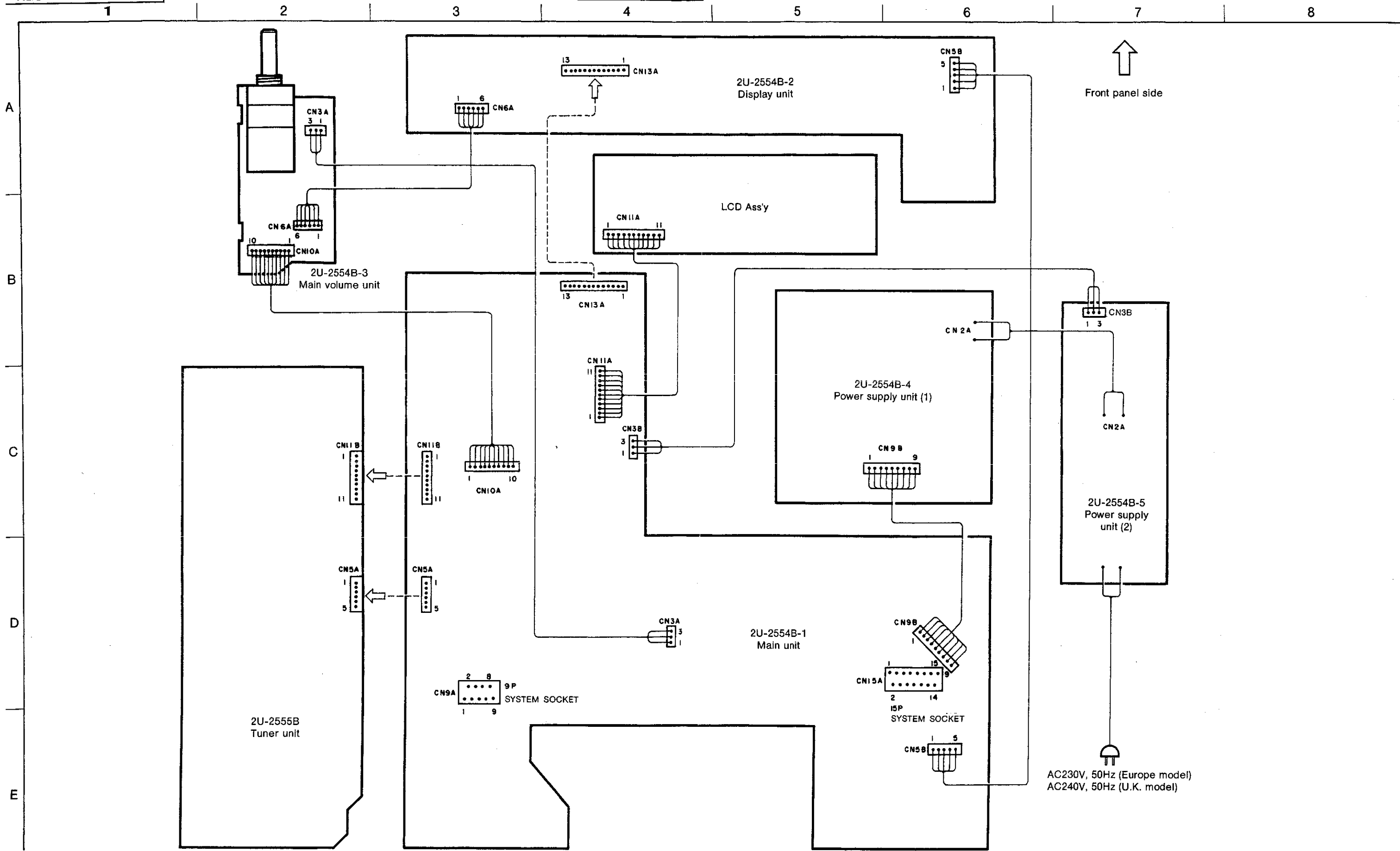

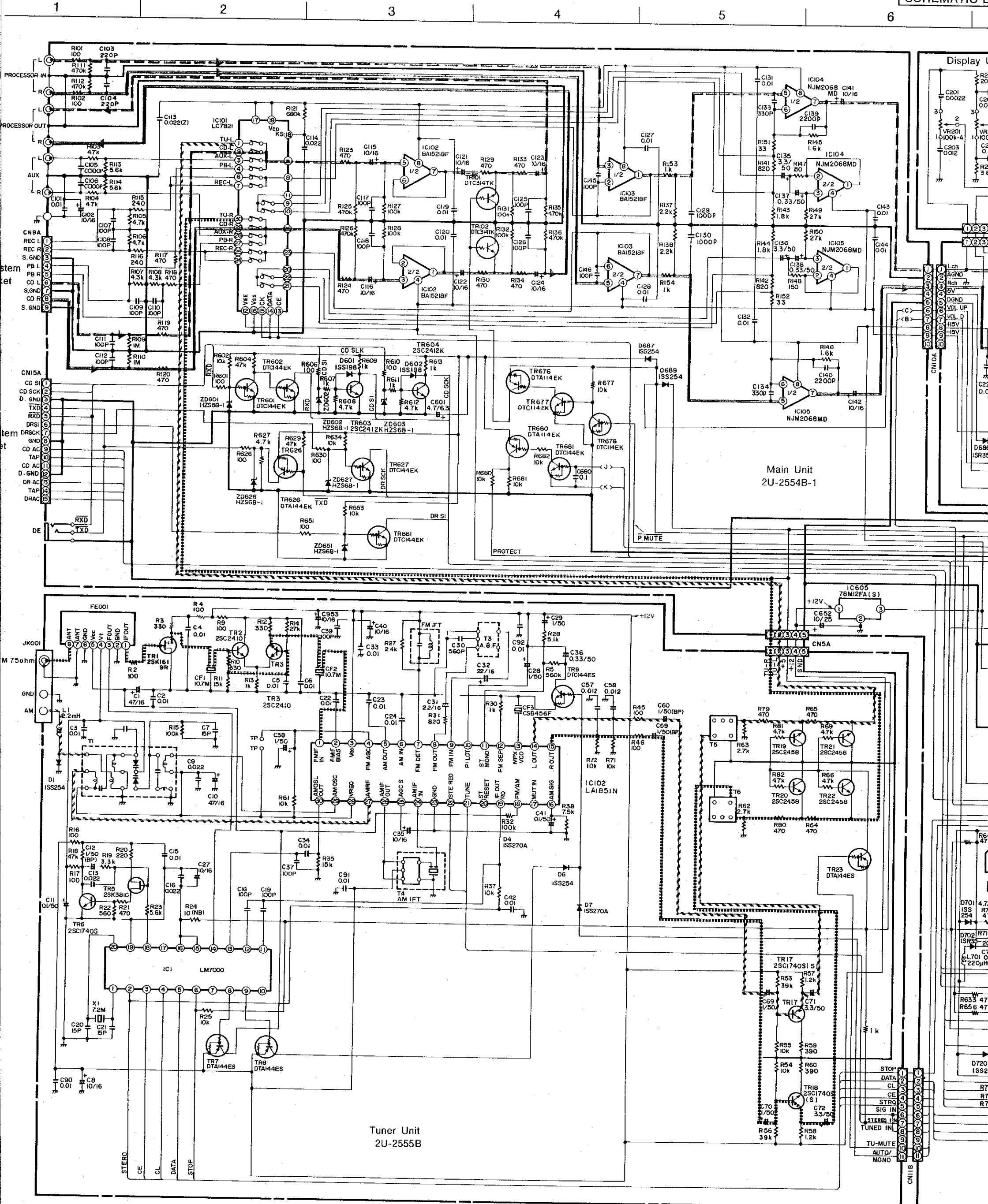

Rch Signal Line
 Lch Signal Line
 Tuner Rch Signal Line
 Tuner Lch Signal Line
 + B Line
 - B Line
 FM Signal Line
 AM Signal Line

WARNING:
 Parts marked with this symbol Δ have critical characteristics.
 Use ONLY replacement parts recommended by the manufacturer.

CAUTION:
 Before returning the unit to the case, leakage current exceeds 0.5 milliamps, the unit is defective.

WARNING:
 DO NOT return the unit to the case if the leakage current exceeds 0.5 milliamps.

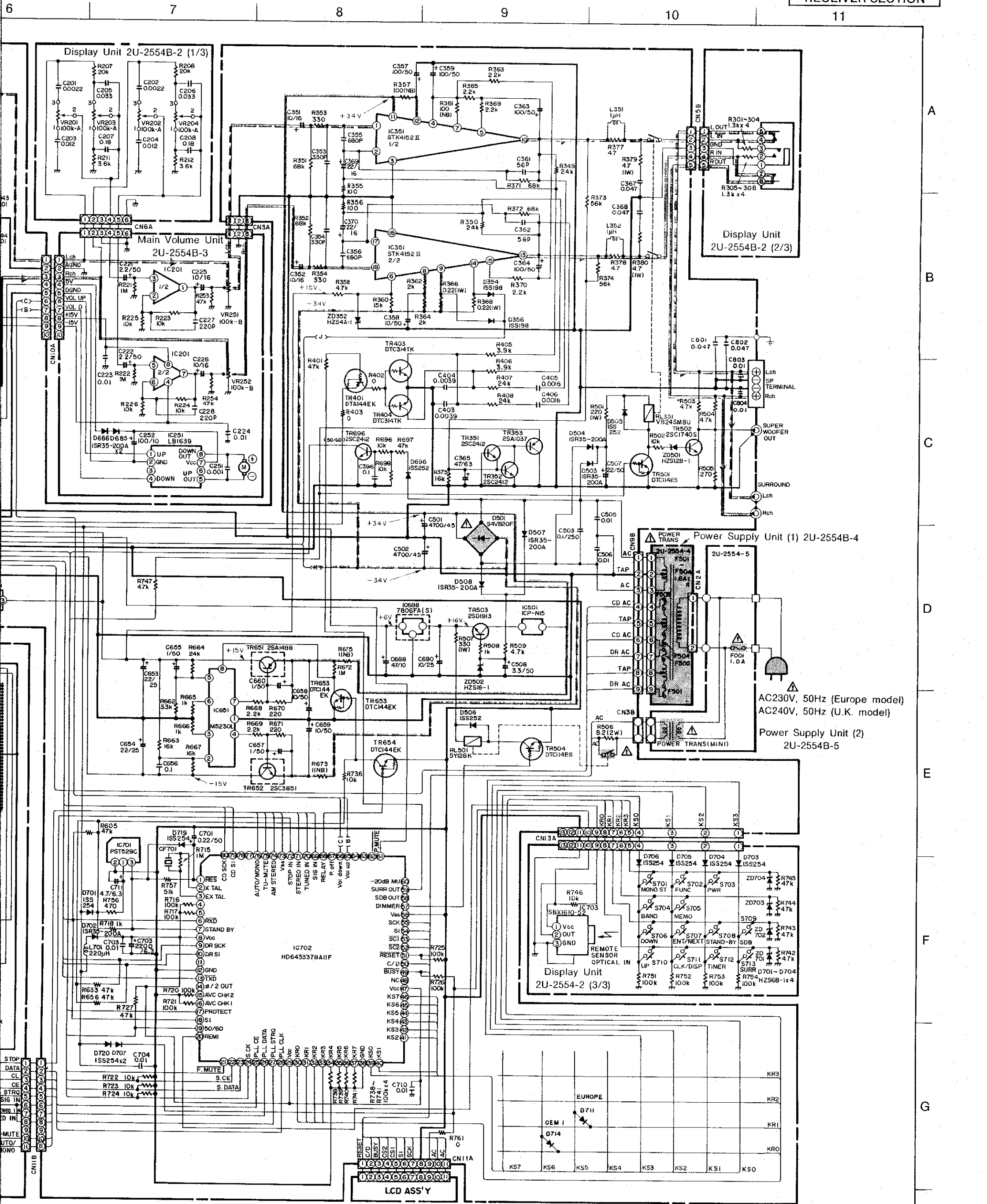

CAUTION:
 Before returning the unit to the customer, make sure you make either (1) a leakage current check or (2) a line to chassis resistance check. If the leakage current exceeds 0.5 milliamperes, or if the resistance from chassis to either side of the power cord is less than 240 Kohms, the unit is defective.

WARNING:
 Do not return the unit to the customer until the problem is located and corrected.

NOTES

ALL RESISTANCE VALUES IN OHM K=1,000 OHM M=1,000,000 OHM
 ALL CAPACITANCE VALUES IN MICRO FARAD P=MICRO-MICRO FARAD
 EACH VOLTAGE AND CURRENT ARE MEASURED AT NO SIGNAL INPUT CONDITION.
 CIRCUIT AND PARTS ARE SUBJECT TO CHANGE WITHOUT PRIOR NOTICE.

RECEIVER SECTION

EXPLODED VIEW

PARTS LIST OF UDRA-65 EXPLODED VIEW

Ref. No.	Part No.	Part Name	Remarks	Qty
1	2U- 2555 B	Tuner Unit Ass'y		1
2	216 0093 007	FM Front End(U)	FE001	1
3	205 0776 007	3 P Ant. Terminal(PAL)		1
4	2U- 2554 B	Main Unit Ass'y		1
4-1	—	Main Unit		(1)
4-2	—	Display Unit		(1)
4-3	—	Main Volume Unit		(1)
4-4	—	Power Supply Unit (1)		(1)
4-5	—	Power Supply Unit (2)		(1)
5	254 4424 700	Chemicon 4700µF/45 V	C-501,502	2
6	214 0166 006	Relay(SY-128-K)	RL501	1
7	211 0749 107	Variable Resistor 100k ohm	Main	1
8	211 0796 008	Variable Resistor 100k ohm	Tone	2
9	205 1015 028	Power Trans(Mini)	PT001	1
10	205 1015 028	Power Trans(Mini)	PT001	1
11	205 0592 003	4 P Push Terminal		1
12	204 8439 000	3 P Pin Jack		1
13	204 8436 003	6 P Pin Jack		1
14	204 8421 005	Mini Jack		1
15	204 8437 002	Headphone Jack		1
16	204 8059 007	Power Trans(Mini)		1
17	411 9115 028	Main Chassis		1
18	124 0079 007	Felt Sheet		4
19	417 0482 004	Radiator		1
20	412 3671 105	Trans Bracket		1
21	412 2814 028	Card Spacer(L=10)		2
22	412 3470 102	Spring Plate		1
23	205 8049 105	Power Trans		1
24	146 1447 201	Front Panel		1
25	143 0841 003	Window		1
26	143 0504 007	Remocon Window		1
27	412 2741 036	P.W.B. Holder(H=10)		2
28	113 1585 105	Function Button		1
29	393 6001 002	LCD Ass'y		1
30	445 0056 008	Cord Bush		1
31	205 2091 000	Ant. Cord w/Conn		1
32	105 1081 116	Rear Panel		1
33	204 2586 001	15 P System Conn. Cord		1
34	204 2587 000	9 P System Conn. Cord		1
35	445 0033 005	Wire Clamp Band		3
36	205 0752 005	Short Pin		2
37	112 0707 127	Main Volume Knob Ass'y		1
38	112 0729 105	Knob		2
39	102 0537 028	Top Cover		1
40	513 2119 000	Rating Sheet		1
41	—	—		—
42	205 0536 085	7 P Conn. Socket	Tuner Unit	1
43	205 0536 098	11 P Conn. Socket	Tuner Unit	1
44	214 0154 005	Relay(VB24SMBU)		1
45	461 0758 049	Rubber Sheet	10X10XT6	1
46	415 0702 102	Shield Plate		1
47	461 0415 007	Rubber Sheet	10X12XT2	1
48	461 0665 019	Rubber Sheet		1
49	513 2171 006	Honologation Label		1
50	412 3708 201	Earth Plate		1
SCREWS				
71	473 7500 044	Tapping Screw (P) 3X8	Black	3
72	473 7007 000	Tapping Screw (S) 4X8	Black	9
73	473 7002 021	Tapping Screw (S) 3X8	Black	7
74	473 3823 000	Tapping Screw (I) 3X20	Black with W.	2
75	473 8007 025	Cup Screw 3X8		2
76	473 7505 007	Tapping Screw (P) 2.6X8		12
77	—	—		—
78	477 0064 107	Fixing Screw		7
79	473 7015 018	Tapping Screw (S) 3X8	Black	10
80	—	—		—
81	—	—		—
82	—	—		—
PACKING & ACCESSORIES (Not included EXPLODED VIEW)				
101	505 0241 005	Cabinet Cover		1
102	503 1090 000	Cushion		1
103	—	—		—
104	—	—		—

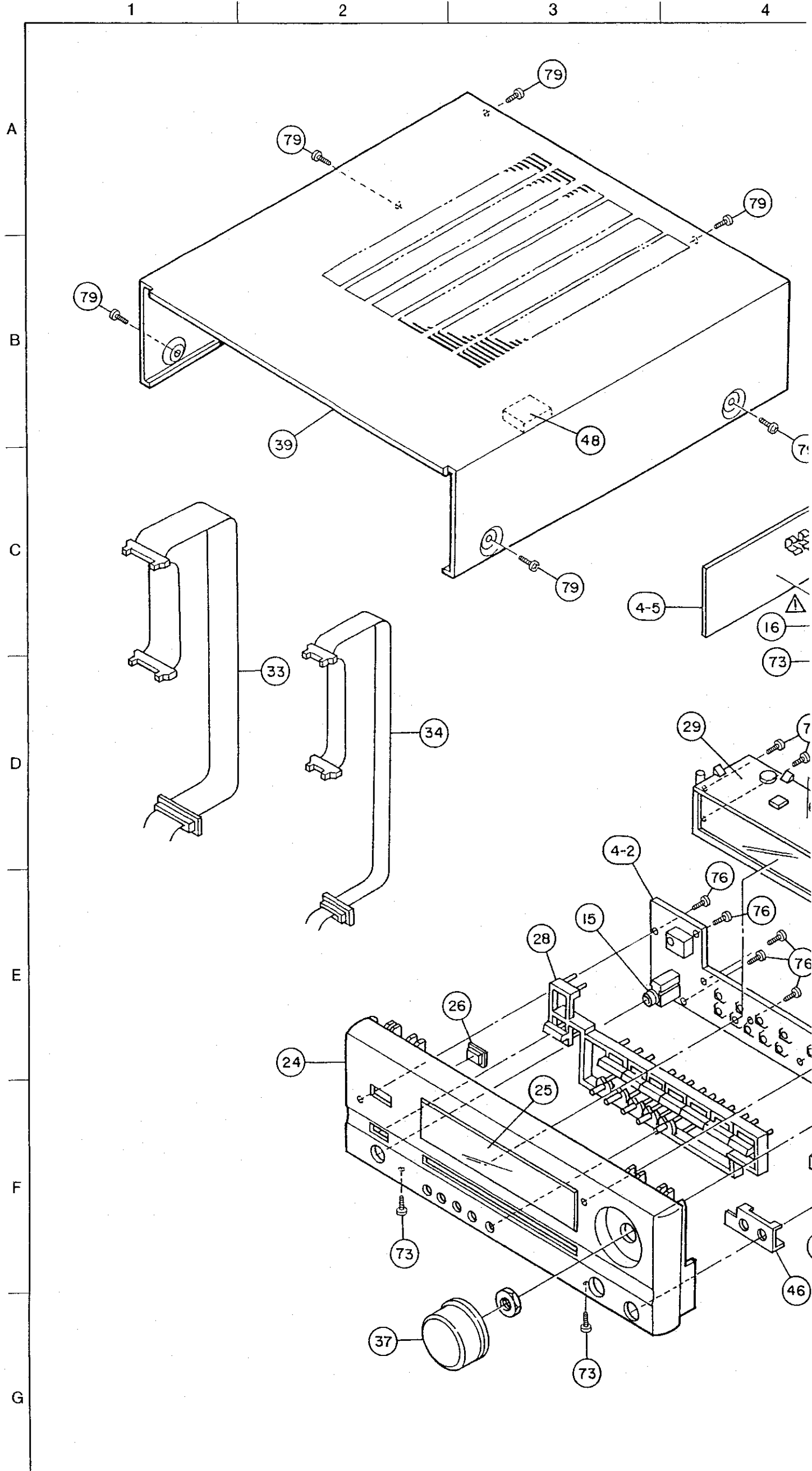

NOTE ON PARTS LIST

- Part indicated with the mark "●" are not always in stock and possibly to take a long period of time for supplying, or in some case supplying of part may be refused.
- When ordering of part, clearly indicate "1" and "1" (i) to avoid mis-supplying.
- Ordering part without stating its part number can not be supplied.
- Part indicated with the mark "★" is not illustrated in the exploded view.

WARNING:

Parts marked with this symbol  have critical characteristics. Use ONLY replacement parts recommended by the manufacturer.

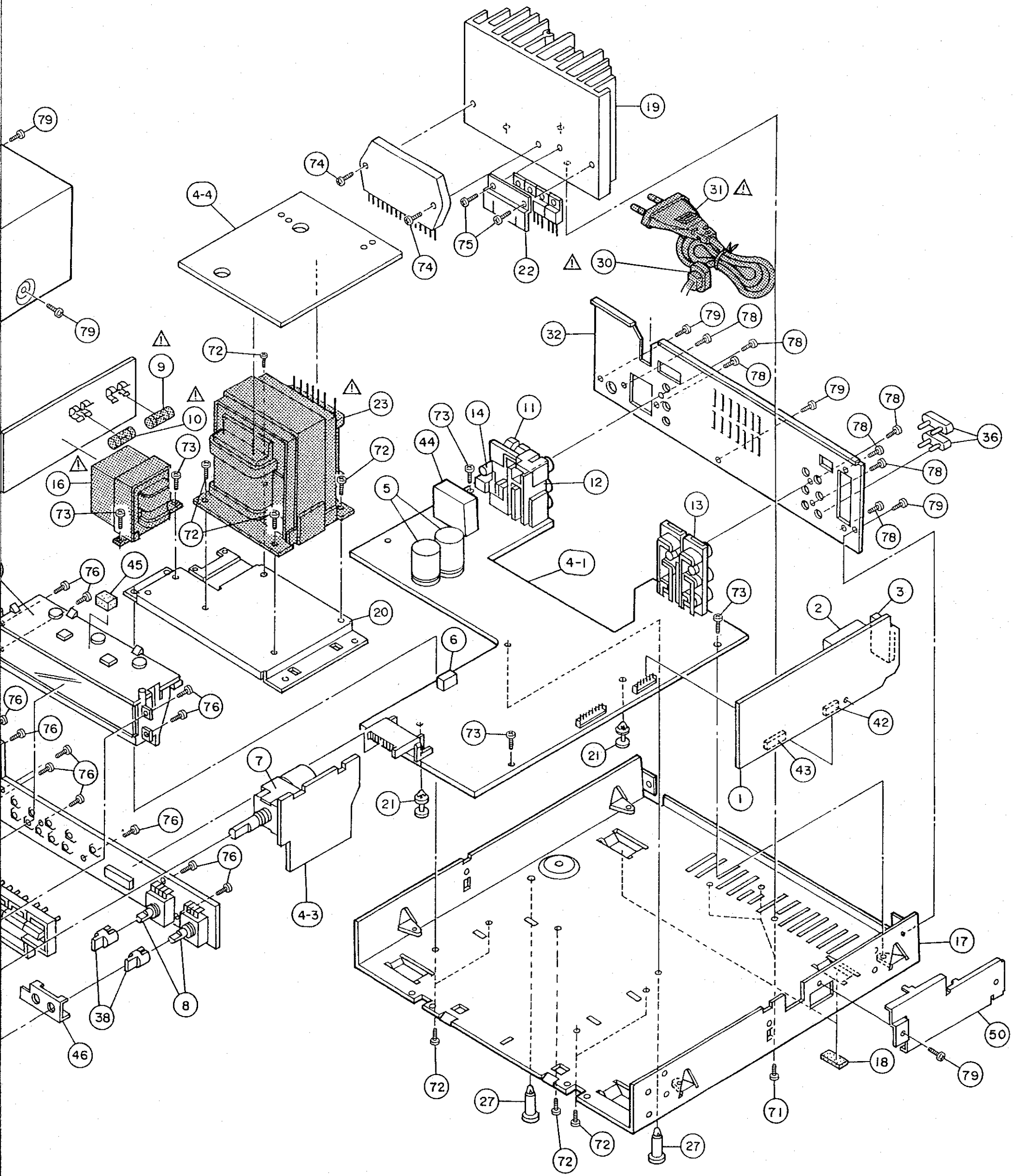

ing, or in some case

REMOTE CONTROL UNIT (RC-164: Part No.: 399 0202 009)

RECEIVER SECTION

Schematic Diagram

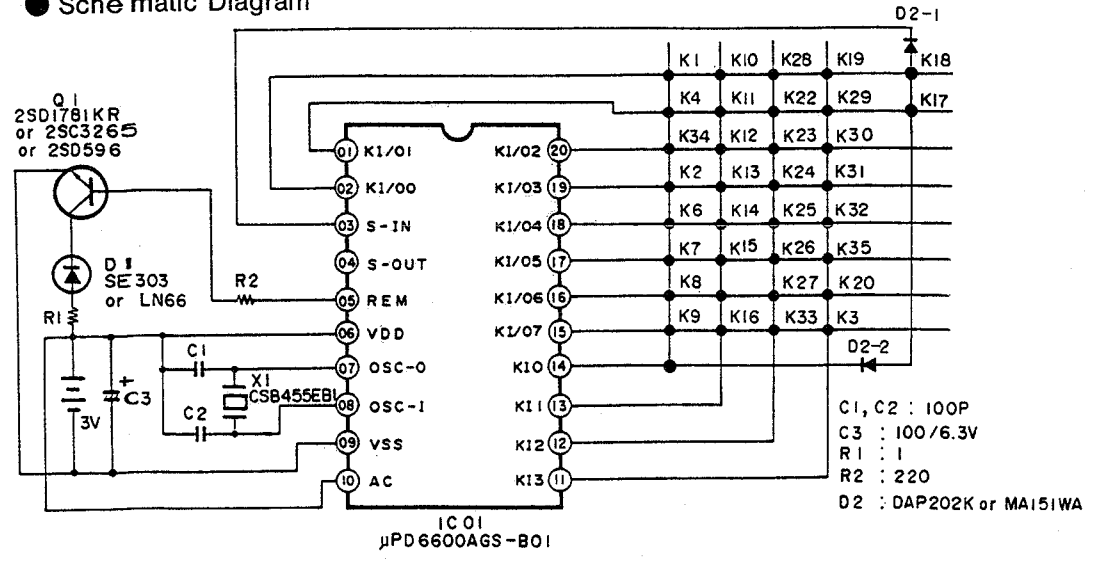

NOTES
 ALL RESISTANCE VALUES IN OHM K=1,000 OHM M=1,000,000 OHM
 ALL CAPACITANCE VALUES IN MICRO FARAD P=MICRO-MICRO FARAD
 EACH VOLTAGE AND CURRENT ARE MEASURED AT NO SIGNAL INPUT CONDITION.
 CIRCUIT AND PARTS ARE SUBJECT TO CHANGE WITHOUT PRIOR NOTICE.

After sending the tuner (K5) key and immediately after inserting the batteries, K6 through K16 are to send the tuner number keys and the + number key codes.

Tuner Mode

Key No.	System Address					Data Code					Expansion	Mask	Judgment	Registration code	Notes	
	C1	C2	C3	C4	C5	C6	C7	C8	C9	C10						C11
1	0	0	1	1	0	0	0	0	0	1	0	1	0	0	0	POWER
2	0	0	1	1	0	0	1	0	0	1	1	1	0	0	0	SLEEP
3	0	0	1	1	0	1	1	0	1	0	0	1	0	0	0	MUTE
4	0	0	1	1	0	1	1	1	1	0	1	0	0	0	0	FUNCTION
5	0	0	1	1	0	1	0	0	1	1	0	1	0	0	0	TUNER
6	0	0	1	1	0	0	1	0	0	0	0	1	0	0	0	1 (DRA mode)
7	0	0	1	1	0	1	1	0	0	0	0	1	0	0	0	2 ↑
8	0	0	1	1	0	0	0	1	0	0	0	1	0	0	0	3 ↑
9	0	0	1	1	0	1	0	1	0	0	0	1	0	0	0	4 ↑
10	0	0	1	1	0	0	1	1	0	0	0	1	0	0	0	5 ↑
11	0	0	1	1	0	1	1	1	0	0	0	1	0	0	0	6 ↑
12	0	0	1	1	0	0	0	0	1	0	0	1	0	0	0	7 ↑
13	0	0	1	1	0	1	0	0	1	0	0	1	0	0	0	8 ↑
14	0	0	1	1	0	1	1	0	0	0	1	1	0	0	0	9 ↑
15	0	0	1	1	0	0	0	1	0	0	1	1	0	0	0	10 ↑
16	0	0	1	1	0	1	1	1	1	0	1	1	0	0	0	+10 ↑
17	0	0	0	1	0	1	1	1	0	1	0	1	0	0	0	DIRECT
18	0	0	0	1	0	1	0	1	1	0	0	1	0	0	0	PROGRAM
19	0	0	0	1	0	1	0	0	0	1	0	1	0	0	0	CANCEL
20	0	0	1	1	0	1	0	1	1	0	0	1	0	0	0	VOL UP
21	0	0	1	1	0	0	0	1	1	0	0	1	0	0	0	VOL DOWN
22	0	0	1	0	0	1	1	1	0	1	0	1	0	0	0	R. PLAY ◀
23	0	0	1	0	0	0	1	1	1	1	0	1	0	0	0	STOP ■
24	0	0	1	0	0	0	0	1	1	1	0	1	0	0	0	F. PLAY ▶
25	0	0	1	0	0	1	1	0	1	1	0	1	0	0	0	REW ◀◀
26	0	0	1	0	0	0	0	1	1	0	1	0	0	0	0	FF ▶▶
27	0	0	1	0	0	1	1	1	1	1	0	1	0	0	0	REC/REC MUTE
28	0	0	1	0	0	1	1	0	0	1	0	1	0	0	0	TAPE 1/2
29	0	0	0	1	0	0	1	1	1	1	0	1	0	0	0	STOP ■
30	0	0	0	1	0	0	0	1	1	1	0	1	0	0	0	PLAY ▶
31	0	0	0	1	0	1	1	0	1	1	0	1	0	0	0	M-SEARCH L ◀◀
32	0	0	0	1	0	0	1	0	1	1	0	1	0	0	0	M-SEARCH R ▶▶
33	0	0	0	1	0	1	1	0	1	0	1	1	0	0	0	DISC
34	0	0	0	1	0	0	0	0	0	0	0	0	0	0	0	GEQ
35	0	0	0	1	0	0	1	0	1	0	1	1	1	0	0	SDB

Block Diagram

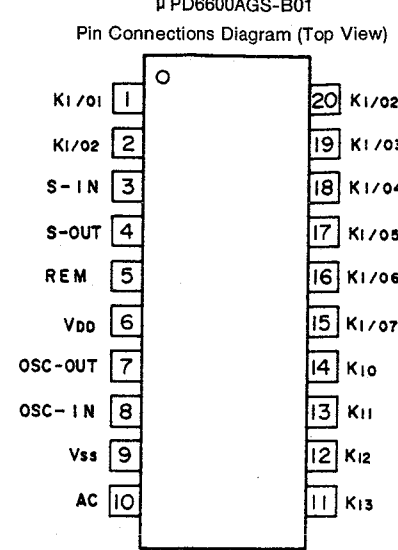

Transistors

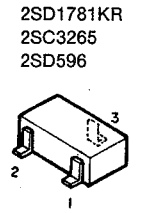

Diodes

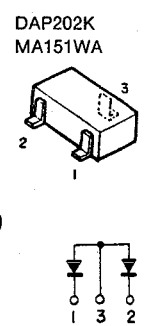
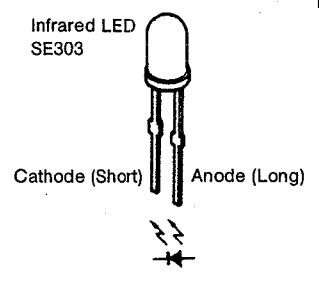

After sending the direct (K17) or program (K18) key, K6 through K16 are to send the CD number keys and the + number key codes.

CD Mode

Key No.	System Address					Data Code					Expansion	Mask	Judgment	Registration code	Notes	
	C1	C2	C3	C4	C5	C6	C7	C8	C9	C10						C11
6	0	0	0	1	0	0	1	0	0	0	0	1	0	0	0	1
7	0	0	0	1	0	1	1	0	0	0	0	1	0	0	0	2
8	0	0	0	1	0	0	0	0	1	0	0	1	0	0	0	3
9	0	0	0	1	0	1	0	1	0	0	0	1	0	0	0	4
10	0	0	0	1	0	0	1	1	0	0	0	1	0	0	0	5
11	0	0	0	1	0	1	1	1	0	0	0	1	0	0	0	6
12	0	0	0	1	0	0	0	0	1	0	0	1	0	0	0	7
13	0	0	0	1	0	1	0	0	1	0	0	1	0	0	0	8
14	0	0	0	1	0	0	1	0	1	0	0	1	0	0	0	9
15	0	0	0	1	0	0	0	1	1	0	0	1	0	0	0	10
16	0	0	0	1	0	0	0	0	0	1	0	1	0	0	0	+10

After the K34 key is switched on, the K6 through K10 keys send the code for GEQ, but K11 through K16 must not send anything.

GEQ Mode

Key No.	System Address					Data Code					Expansion	Mask	Judgment	Registration code	Notes	
	C1	C2	C3	C4	C5	C6	C7	C8	C9	C10						C11
6	0	0	0	1	0	0	1	1	1	0	1	1	1	0	0	AV FUNC
7	0	0	0	1	0	0	1	0	0	0	0	1	1	0	0	PEQ
8	0	0	0	1	0	1	1	1	0	0	0	1	1	0	0	UEQ
9	0	0	0	1	0	1	1	1	1	0	0	1	1	0	0	FLAT
10	0	0	0	1	0	0	1	1	0	0	1	1	1	0	0	SE
11	0	0	0	1	0											
12	0	0	0	1	0											
13	0	0	0	1	0											
14	0	0	0	1	0											
15	0	0	0	1	0											
16	0	0	0	1	0											

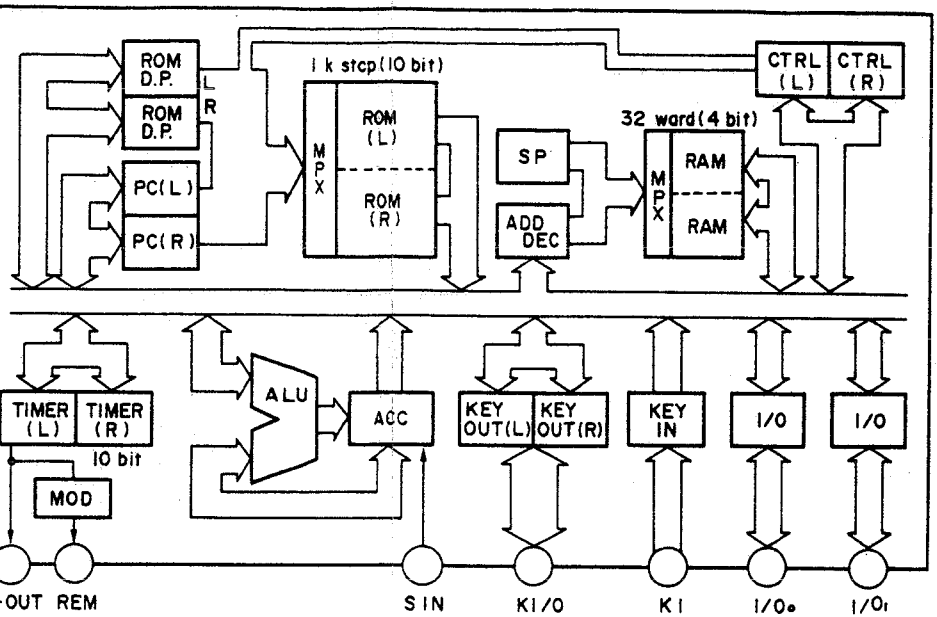

After sending the tuner (K5) key and immediately after inserting the batteries, K6 through K16 are to send the tuner number keys and the + number key codes.

Tuner Mode

Key No.	System Address					Data Code					Expansion	Mask	Judgment	Registration code	Notes	
	C1	C2	C3	C4	C5	C6	C7	C8	C9	C10						C11
6	0	0	1	1	0	0	1	0	0	0	0					1 (DRA mode)
7	0	0	1	1	0	1	1	0	0	0	0					2 ↑
8	0	0	1	1	0	0	0	1	0	0	0					3 ↑
9	0	0	1	1	0	1	0	1	0	0	0					4 ↑
10	0	0	1	1	0	0	1	1	0	0	0					5 ↑
11	0	0	1	1	0	1	1	1	0	0	0					6 ↑
12	0	0	1	1	0	0	0	0	1	0	0					7 ↑
13	0	0	1	1	0	1	0	0	1	0	0					8 ↑
14	0	0	1	1	0	1	1	0	0	0	1					9 ↑
15	0	0	1	1	0	0	0	1	0	0	1					10 ↑
16	0	0	1	1	0	1	1	1	1	0	1					+10 ↑

A

B

C

D

E

CD PLAYER SECTION

DISASSEMBLY PROCEDURES

(Follow these procedures in reverse order to reassemble.)

1. Removing the Top Cover and the Front Panel

- 1) Remove the six screws that fasten the top cover.
- 2) The top cover is held in the rib of the front panel. Caution is required when taking off the top cover since if it is not removed in the direction of the arrow (vertically), the rib might be bent.

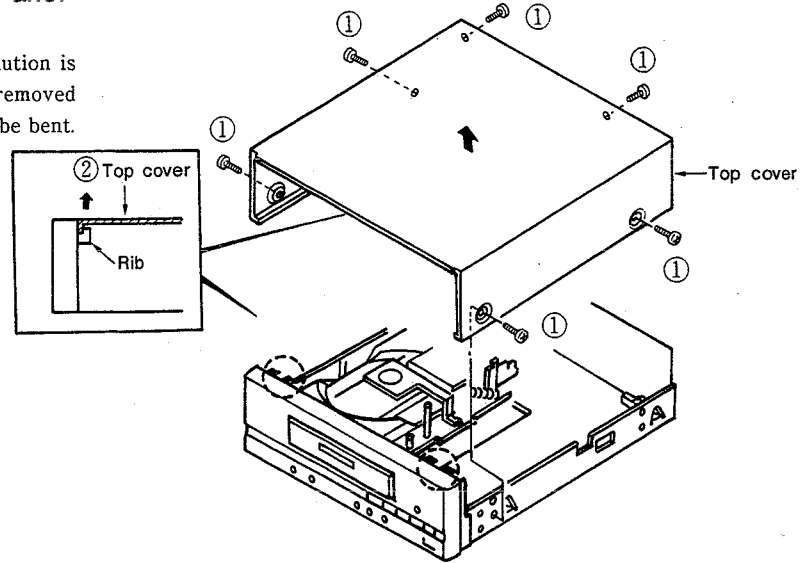

- 3) Remove the four screws that fasten the front panel.
- 4) While releasing the hooks of the front panel from the chassis, remove the front panel in the direction of the arrow.

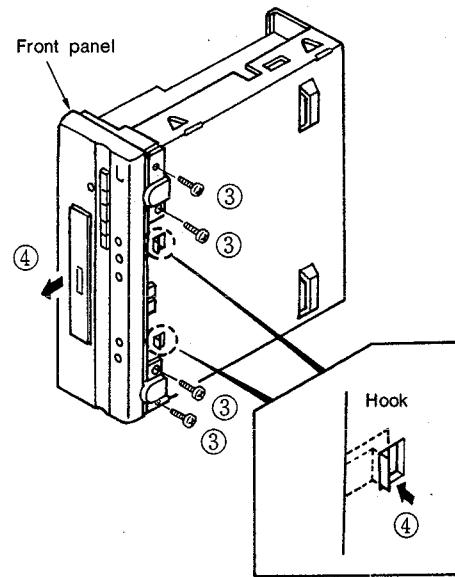

2. Removing the Various Units

Display Unit (2U-2557-2)

- 1) Remove the seven screws which fasten the display unit.

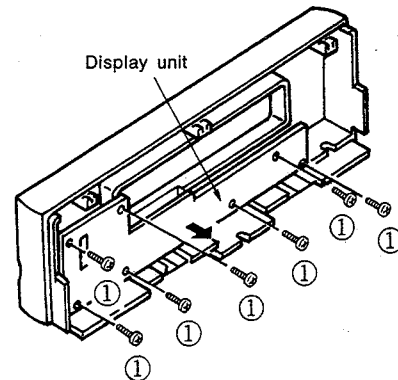

3. Removing the CD Mechanical Unit

- 2) Disconnect the BC500, 501, 502, and 503 connectors which are attached to the main board.
- 3) Remove the four screws which fasten the CD mechanical unit, then remove the mechanical unit in the direction of the arrow.

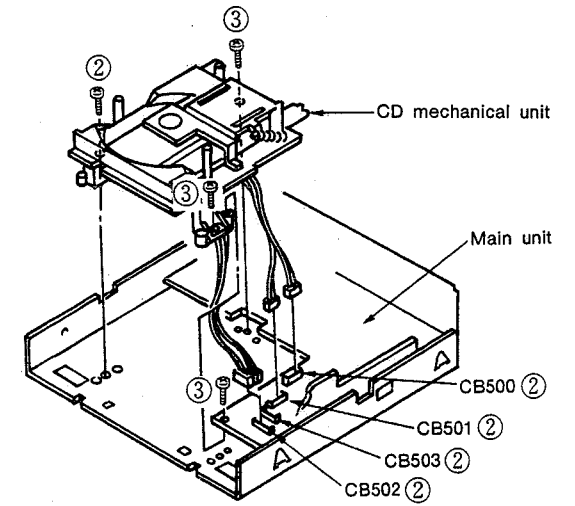

Connector Unit (2U-2557-3)

- 4) Pull off the connector unit from the connectors in the direction of the arrow.

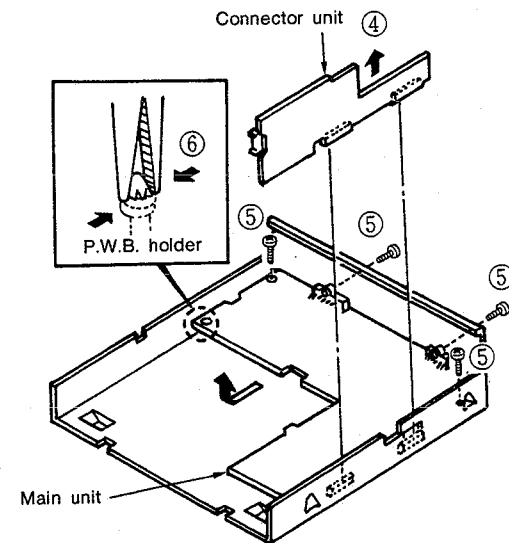

Main Unit (2U-2557-1)

- 5) Remove the four screws which fasten the main unit.
- 6) While removing the P.W.B. holder with pliers, remove the main unit in the direction of the arrow.

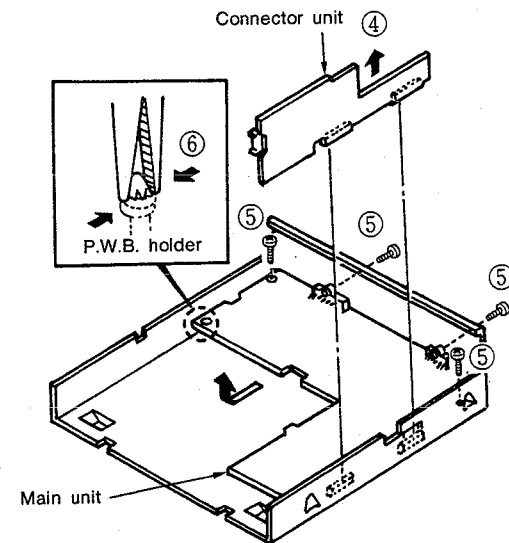

BLOCK DIAGRAM

CD PLAYER SECTION

1 2 3 4 5 6 7 8

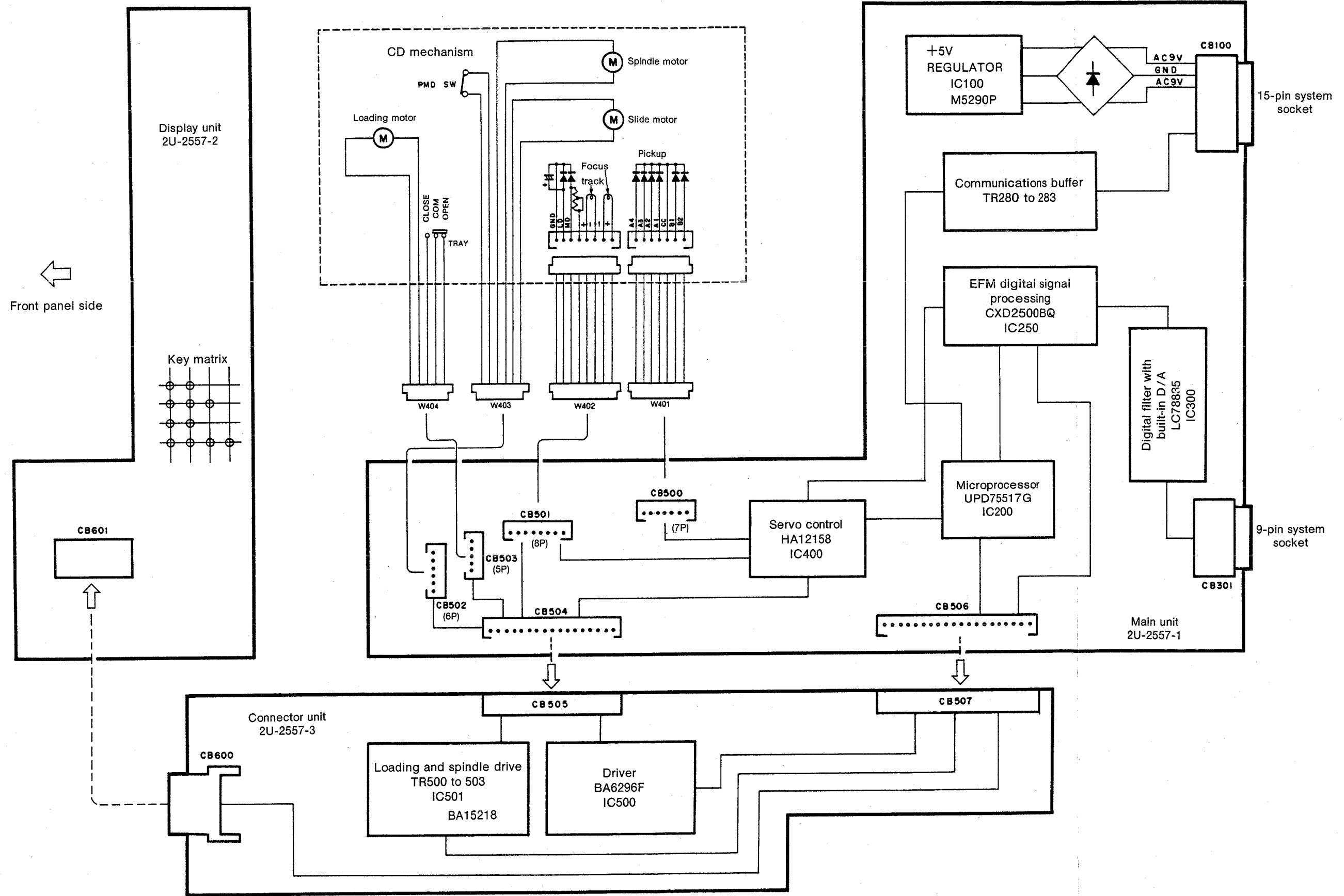

Connections Diagram

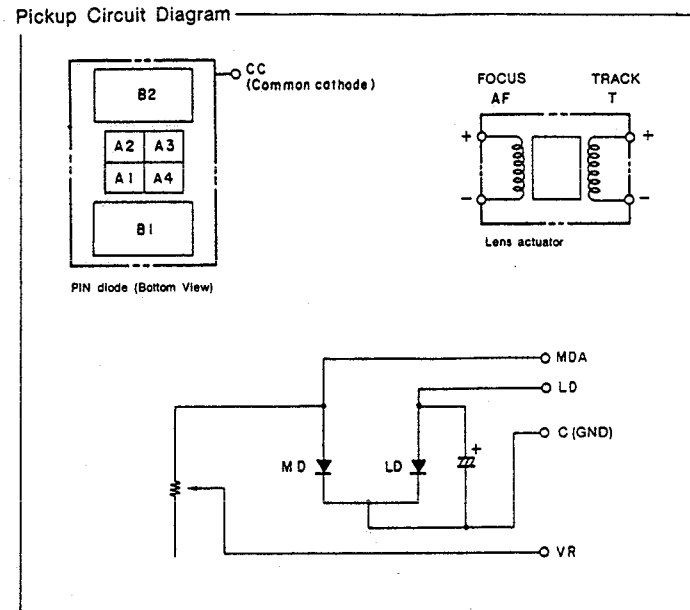

1. PD connector

PH pin post 7 pins (Type number B7B-PH-K-S manufactured by Nippon Atchaku Tanshi Hanbai K.K.)

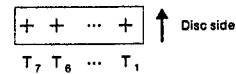

Tn	1	2	3	4	5	6	7
Item	A ₄	A ₃	A ₂	A ₁	CC	B ₁	B ₂

2. LD actuator connector

PH pin post 8 pins (Type number B8B-PH-K-S manufactured by Nippon Atchaku Tanshi Hanbai K.K.)

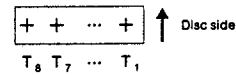

Tn	1	2	3	4	5	6	7	8
Item	C (GND)	LD	MD	-VR	TR+	TR-	AF-	AF+

● Precautions in Handling

This mechanism has been precisely assembled and adjusted at a special factory. It should not be disassembled or adjusted without good reason. Pay attention to the following points related to handling.

1. General items

(1) Storage

Avoid storage in places with high temperatures and high humidity, and in places exposed to a lot of dust.

(2) Handling

The unit has been precisely adjusted and care should be taken so as not to expose the unit to shocks through dropping or careless handling.

2. Semiconductor laser (LD)

(1) Protection of the eyes from the laser

The output of the LD is via an objective lens and is a maximum of 400 μW, but reaches approximately 1.3 × 10⁴W/cm² in places where there is condensed light. After being condensed by the objective lens, the beam widens and so is all right at a distance of 30 cm or further, but during operation the LD should never be allowed to be viewed directly or through another lens or mirror since this is dangerous.

(2) Destruction by surge currents or static electricity

When a large current flows through the LD, even for a very short period, the strong light which the LD generates itself will advance the deterioration of the LD or destroy it.

Wire a switch into the LD drive circuit or provide another method of preventing the flow of surge currents. Also, when handled without care, the LD can be destroyed instantly by the application of static electricity from the body. Therefore, when handling the LD, be sure to ground your body and ground the measuring instruments, jigs, and tools. It is also desirable to use a grounding mat on the work bench and floor.

3. Lens actuator

The actuator section uses a strong magnetic circuit, so that when magnetic bodies come too close, their characteristics are altered. Also be careful not to allow foreign matter to enter from the cover gap.

4. Handling

Be sure not to contact the lens when handling the LD.

Note that direct contact of the body or other objects with the circuit of the LD board will cause deterioration to occur, so sufficient care should be taken. Note that a poor connection related to the LD and actuator connector will cause deterioration of the laser, and so there should not be any looseness of connectors.

SERVICE POINTS

1. Parts replacement of the tray mechanism (Figs. 1 and 2)

(1) Removal of the tray

Open the tray and use a flat-bladed screwdriver to press the stopper portions of Fig. 1 (one each in the left and right locations) in the direction of the black arrow, then remove in the direction of the white arrow.

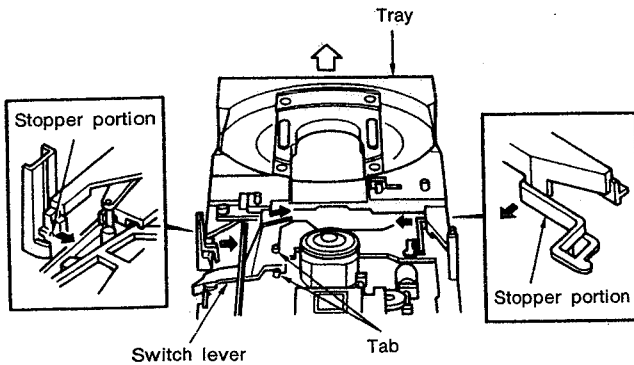

Fig. 1

(2) Mounting of the tray (Figs. 1, 2 and 3)

Turn the switch lever in the direction of the arrow, set the latches of the tray as illustrated in Fig. 2, then set the rails of the tray into the grooves of the loading plate. Press so that the pins of the switch lever enter the grooves of the rack, and while bending the stoppers a little to the inside, press in the tray.

(Check that the latches are in the positions illustrated in Fig. 2.)

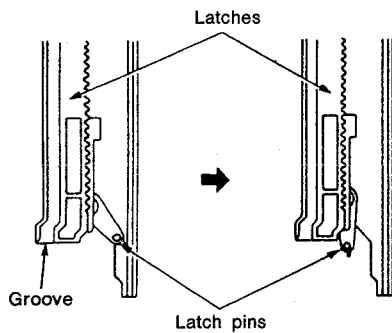

Fig. 2

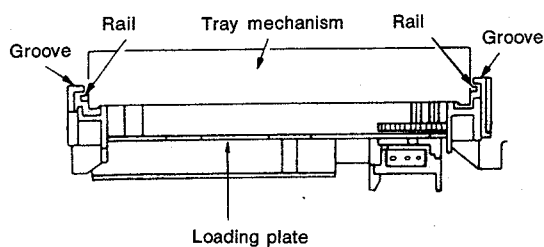

Fig. 3

(3) Replacement of the disc holder (Fig. 4)

With the tray removed, remove tabs (D) and (E) of the disc receptacle of Fig. 4, then lift up and off.

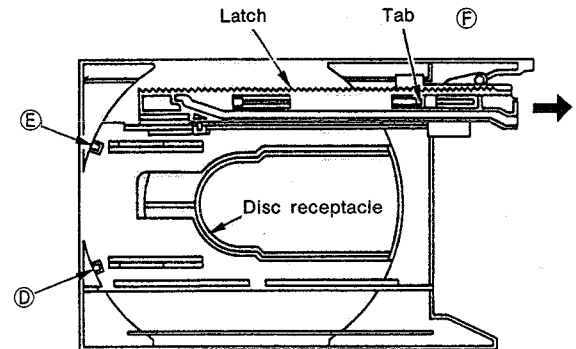

Fig. 4

(4) Replacement of the latches (Fig. 4)

Set the latches into the condition of Fig. 4, lift the latch tab (F) up about 1 mm with a flat-bladed screwdriver and remove the rack in the direction of the arrow.

(5) Replacement of the switch lever (Fig. 1)

Remove the tabs of the bottom side (in 2 locations).

CD PLAYER SECTION

2. Removing the Clamper Arm (Fig. 5)

- 1) Remove the clamper spring.
- 2) Press the support spring in the direction of the arrow and remove.
- 3) Press the hook in the direction of the arrow and remove the shaft of the clamper arm.

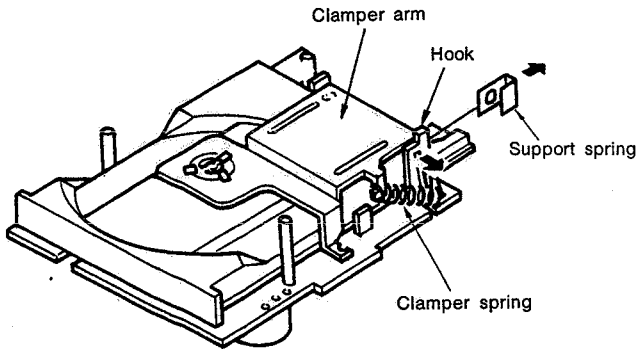

Fig. 5

3. Removing the Clamper (Fig. 6)

- 1) Press one of the clamper tabs to the outside and remove the clamper plate from the tabs.
- 2) Insert a flat-blade screwdriver into the bottom of the raised clamper plate and at this time remove the other two tabs.
- 3) Remove the clamper plate and clamper magnet, then press the tabs of the clamper to the inside and remove the clamper through the bottom side.

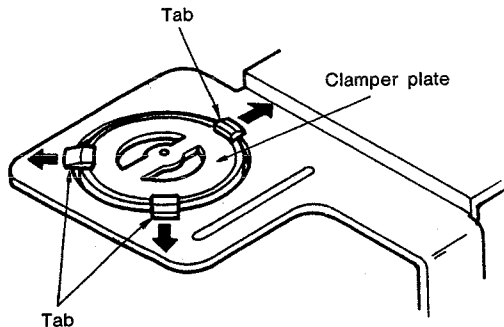

Fig. 6

4. Removing the Pickup (Fig. 7)

Insert a Phillips screwdriver into the crossed indentation of the molded part which fastens the slide bar and turn in the counterclockwise direction.

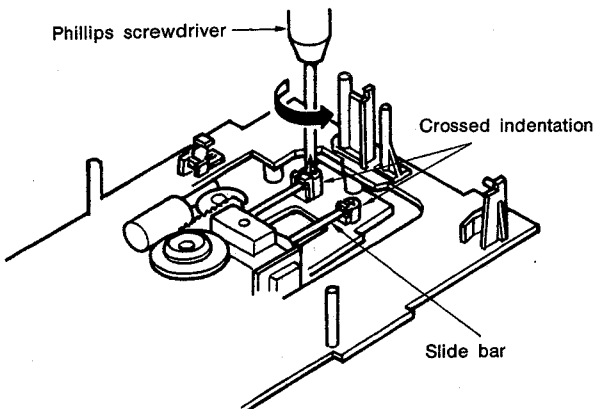

Fig. 7

5. Spindle Motor Assembly Replacement Precautions (Fig. 8)

When replacing the spindle motor assembly leave some slack on the wires of the motor and switch.

Pulling of the wires may cause the sound to skip.

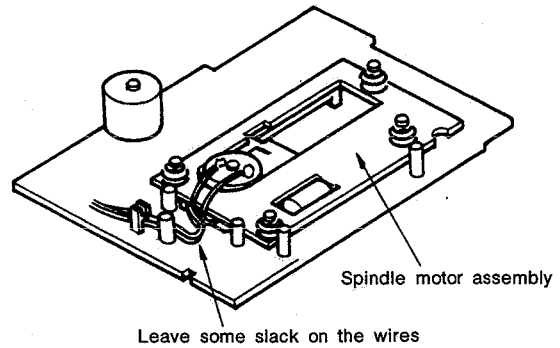

Fig. 8

6. Inspection of the objective lens (Fig. 9)

Handle so as not to get dirt or dust on the objective lens of the lens actuator section. Note that when used for a long period, dirt or dust may have adhered to the objective lens. Try cleaning the surface of the objective lens with a dry, clean cotton swab.

If the dirt still does not come off, moisten the cotton swab with a small amount of water and wipe. When doing this, be careful not to get water on any parts other than the lens.

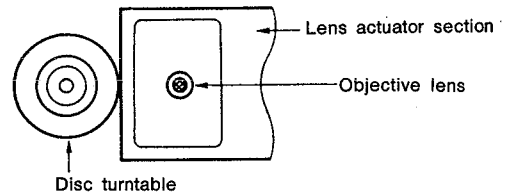

Fig. 9

7. Inspection for laser breakdown

The laser is normally driven with a current of 30 to 80 mA. If this laser drive current value is measured at 120 mA or higher in the circuit, the laser may be thought to be faulty. [The current value is calculated by $\frac{V_1 (V)}{22 (\text{ohm})}$ (R426 is taken to be V_1 .)]

CD PLAYER SECTION

8. Precautions at time of servicing

(1) Semiconductor laser (Fig. 10)

The semiconductor laser is very susceptible to static electricity destruction and surge currents. Be careful never to touch the terminals of the semiconductor laser and the terminals of the flexible board with your hands or a tool.

As illustrated in Fig. 10, the current and light intensity characteristics increase abruptly once the threshold current value is exceeded.

Also note that this threshold current differs a little from laser to laser. In view of this, when replacing the unit mechanism or any work that involves setting the amount of light of the laser, be sure to turn the adjustment control VR400 fully in the counterclockwise direction, and then raise it to the specified value.

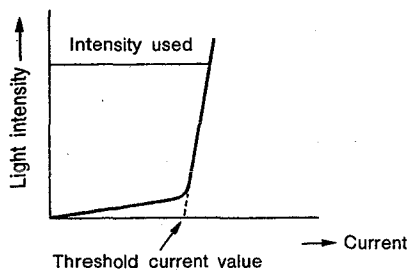

Fig. 10

(2) Handling the unit mechanism (Fig. 11)

When handling the pickup mechanism and the unit mechanism, use a ground ring as the one illustrated in Fig. 11. (A ground ring can be constructed using ordinary lead wire.)

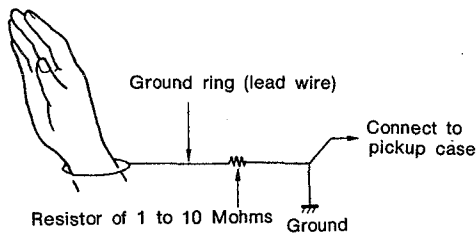

Fig. 11

9. Inspection of the actuator

Check the resistance value of the actuator coil. It is normal if the values are as follows;

Focusing coil 30 ohms

Tracking coil 10 ohms

When the coil is open or shorted, the actuator may be thought to be damaged.

CD PLAYER SECTION

ADJUSTMENT METHOD

The microprocessor contained in this unit incorporates a service program which allows a wide variety of service adjustments to be conducted easily by using the operation buttons.

1. Method of starting the service program

Switch on the AC power while simultaneously pressing the ► PLAY switch and the ▲ OPEN/CLOSE switch of the CD unit (UCD-65). When all power has been switched on there will be a transition to the service program. At this time the display section of the CD unit (UCD-65) display tube will indicate "01".

2. Operation functions when the service program is operating

Operation button	Operation function	Description
▲ OPEN/CLOSE	Opens and closes the disc holder.	<ul style="list-style-type: none"> ● Opening and closing takes place when the rotation of the disc has stopped. ● Other operation buttons are performed when the opening and closing operation is completed.
■ STOP	Stops system operation.	<ul style="list-style-type: none"> ● Track number display becomes 01. ● Press when an adjustment has been completed or is redone.
► PLAY	Operates the focus servo and rotates the disc.	<ul style="list-style-type: none"> ● Press at the time of the tracking offset adjustment. ● After the operation is completed, the track number display becomes 02.
PAUSE	Operates the focus servo, tracking servo, slide servo, and the spindle servo.	<ul style="list-style-type: none"> ● When the play button has been pressed, the tracking servo and slide servo are operated. ● After the operation is completed the track number display becomes 03.
Other buttons	Operation is not normal.	<ul style="list-style-type: none"> ● Do not operate buttons other than the above. ● When a button is operated by mistake, immediately turn the power switch off.

NOTE: Do not use the remote control while the service program is operating.

3. Adjustment method

(1) Measuring instruments required in the adjustment

Oscilloscope

CD PLAYER SECTION

OUTLINE DIAGRAM OF ADJUSTMENT LOCATION

2U-2557-1 CD MAIN UNIT ASS'Y

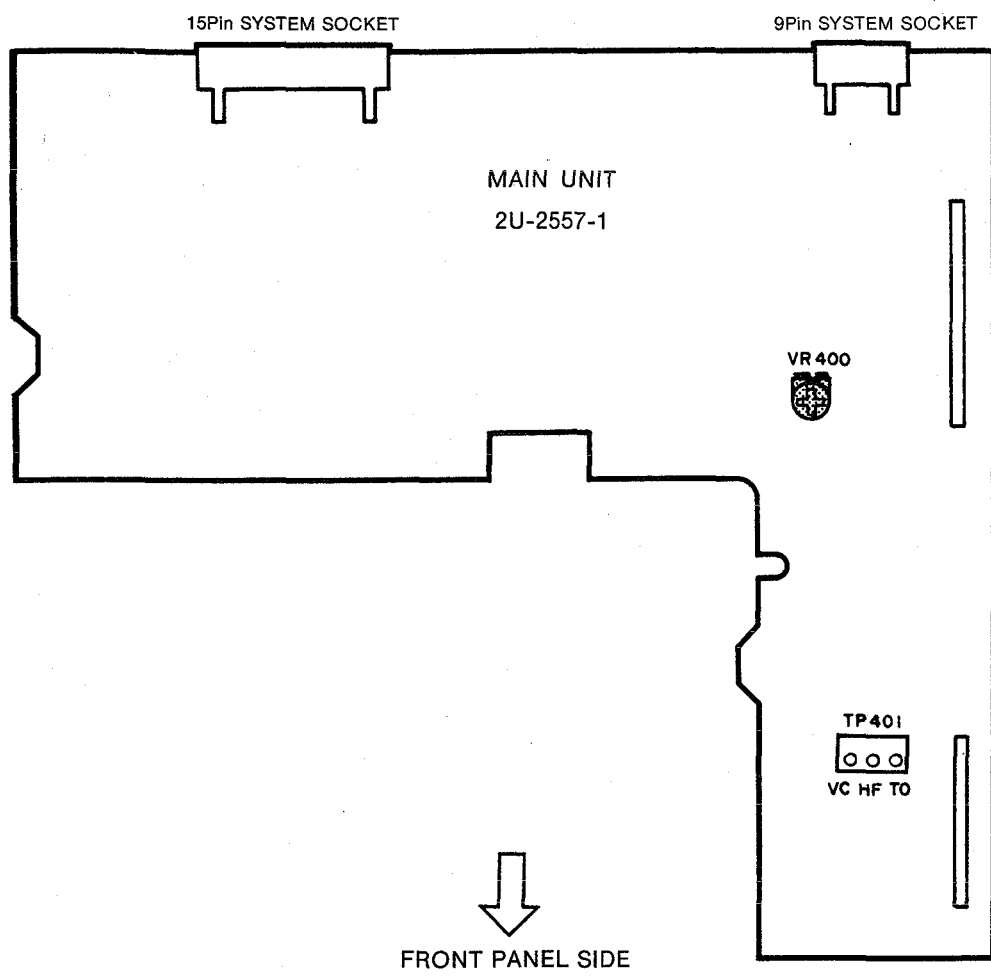

(2) Adjustment preparation

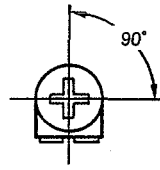
<p>1.</p>	<p>Set the adjustment control (VR400) to the position illustrated.</p>	<p>VR400 (T-OFFSET)</p> 
<p>2.</p>	<p>Adjustment step</p>	<p>1. Tracking offset</p>

CD PLAYER SECTION

(3) Tracking offset adjustment

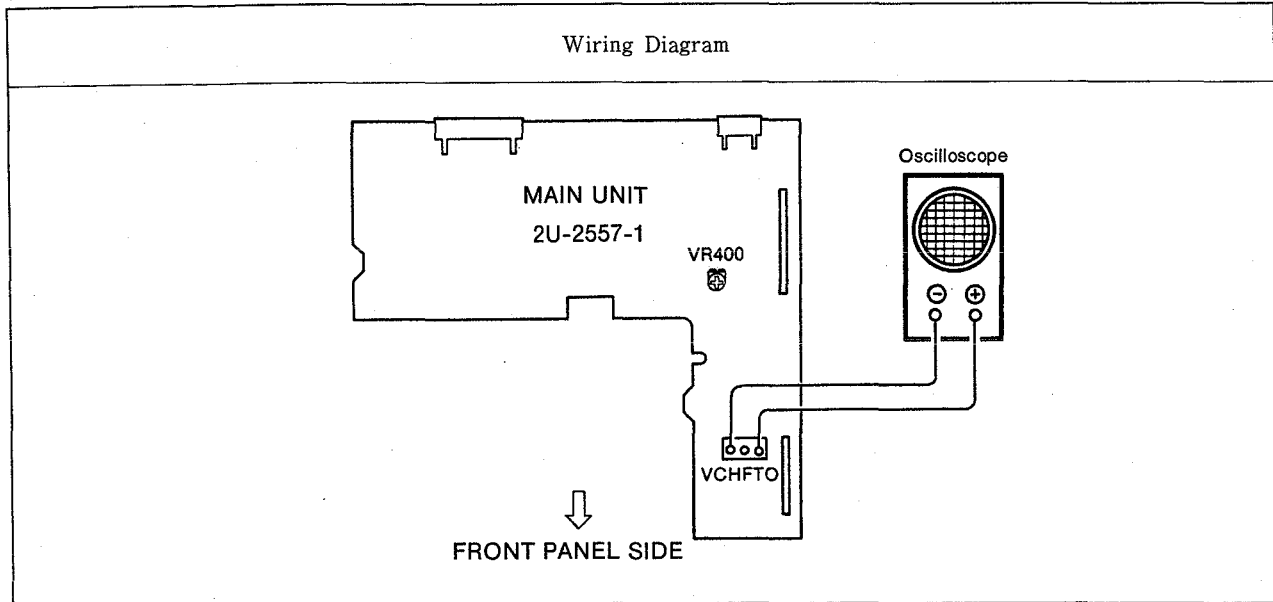

Oscilloscope (DC range)		Adjustment location	Check items	Adjustment procedure
V	H	(Control)	DC Voltmeter	
0.2V/div	1~2ms div	VR400	<p>A = B</p>	<ol style="list-style-type: none"> 1. ▲ OPEN/CLOSE Press the OPEN/CLOSE button and place an adjustment disc in the disc holder. 2. ▲ OPEN/CLOSE Press the OPEN/CLOSE button again and close the disc holder. 3. ▶ PLAY Press the PLAY button and check that the display indicates "02". 4. Short the (+) and (-) terminals of the oscilloscope and check the board wiring. 5. Adjust the VR400 "T-OFFSET" control and set the upper and lower amplitude of the waveform to be equal.

CD PLAYER SECTION

MEMO:

CD PLAYER SECTION

SEMICONDUCTORS

● IC's

HA12158 (IC400)

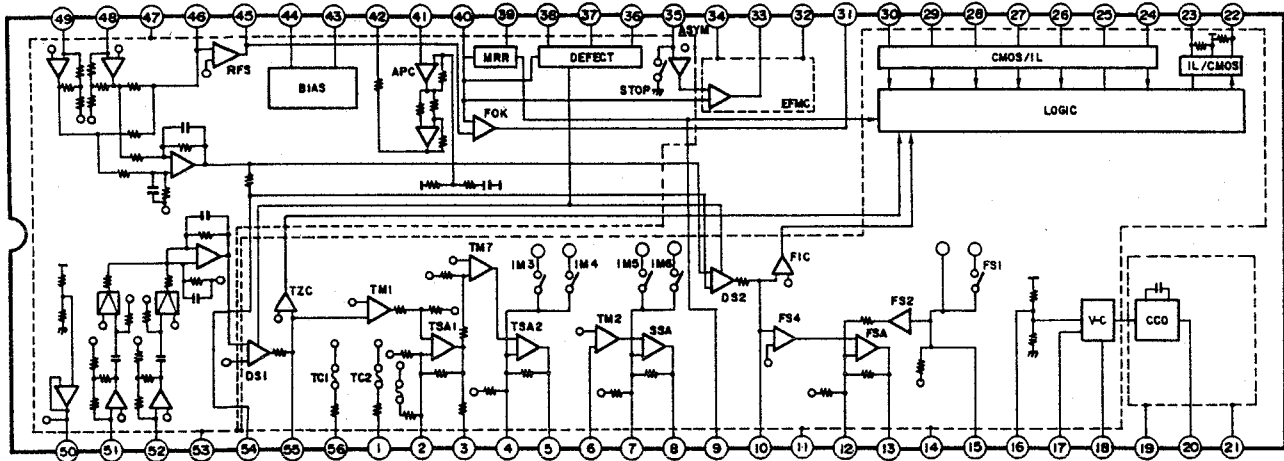
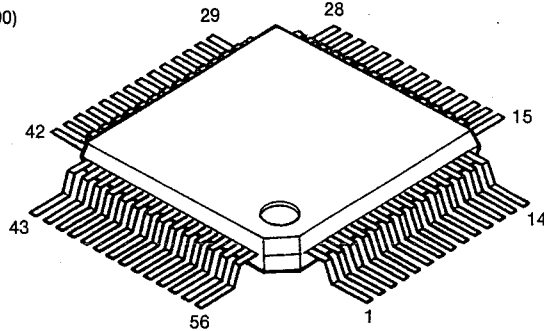

● Pin function table

Pin No.	Symbol	I/O	Function	Pin No.	Symbol	I/O	Function
1	VREF	O	Reference voltage output	29	COUT	O	Track count signal output
2	TR1	I	TR1 (I/V conversion amplifier) input	30	SENS	O	FZC and TZC signal output
3	TR2	I	TR2 (I/V conversion amplifier) input	31	XRST	I	Reset signal output
4	PG	GND	Preamplifier block ground	32	DIRC	I	Direct control signal output
5	FH	O	Focus error hold signal output	33	XLT	I	Data transfer signal input
6	TE	I/O	Track error signal output, TMI input	34	DATA	I	Data signal input
7	TG1	I	TG1 switch	35	CLK	I	Data sync clock input
8	TG2	I	TG2 switch	36	LMSW	I	Limit switch input
9	TS1 \ominus	I	TSA1 \ominus input	37	LDSW	I	Laser switch input
10	TS10	O	TSA1 output	38	FOK	O	FOK comparator output
11	TS2 \ominus	I	TSA2 \ominus input	39	GEFM	GND	EFM comparator ground
12	TS20	O	TSA2 output	40	EFMC	O	EFM comparator output
13	TM2	I	TM2 input	41	VEFM	Vcc	EFM comparator Vcc
14	SS \ominus	I	SSA \ominus input	42	DSLCL	I	Data slice level control input
15	SSO	O	SSA output	43	DFIN	I	Defect comparator input
16	MIRR	O	Mirror comparator output	44	DFO	O	Defect signal output
17	FE	I/O	Focus error signal output, FS4 input	45	DFH	O	Defect hold signal output
18	SG	GND	Servo block ground	46	MIRH	O	Error hold signal output
19	FS \ominus	I	SSA \ominus input	47	EFMI	I	EFM signal output
20	FSO	O	FSA input	48	MD	I	APC amplifier input
21	SVCC	Vcc	Servo block Vcc	49	LD	O	APC amplifier output
22	FUD	O	Focus up/down voltage output	50	BYPS	O	Capacitor connection pin for ripple filter
23	VCR	I/O	VCO reference voltage	51	ISET	O	Reference current setting
24	PDIN	I	VCO control voltage input	52	RFO	O	RFS output
25	FRA	O	VCO free-run frequency setting	53	RF \ominus	I	RFS \ominus input
26	VVcc	Vcc	VCO Vcc	54	PVcc	Vcc	Pre-block Vcc
27	VCO	O	VCO output	55	RF1	I	RF1 (I/V conversion block) input
28	VGND	GND	VCO ground	56	RF2	I	RF2 (I/V conversion block) input

CD PLAYER SECTION

BA6296FP (IC500)

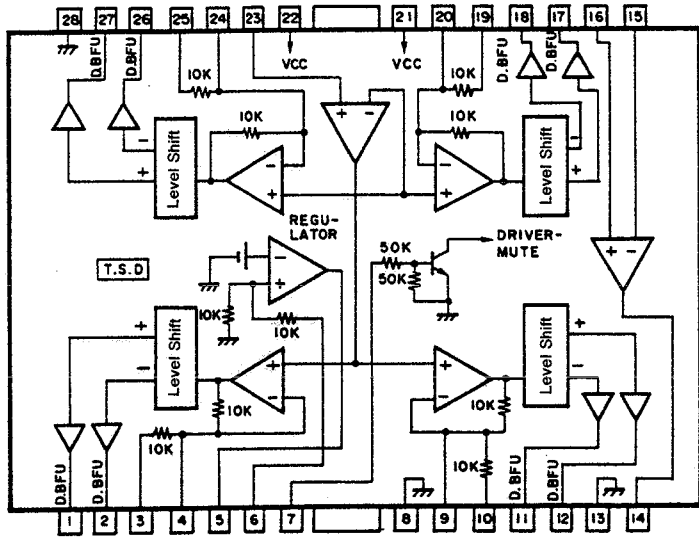
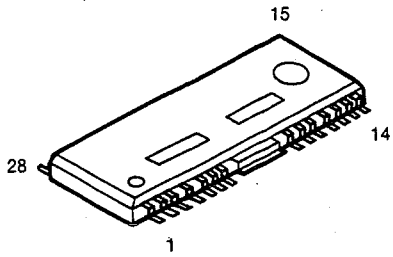

M5290P (IC100)

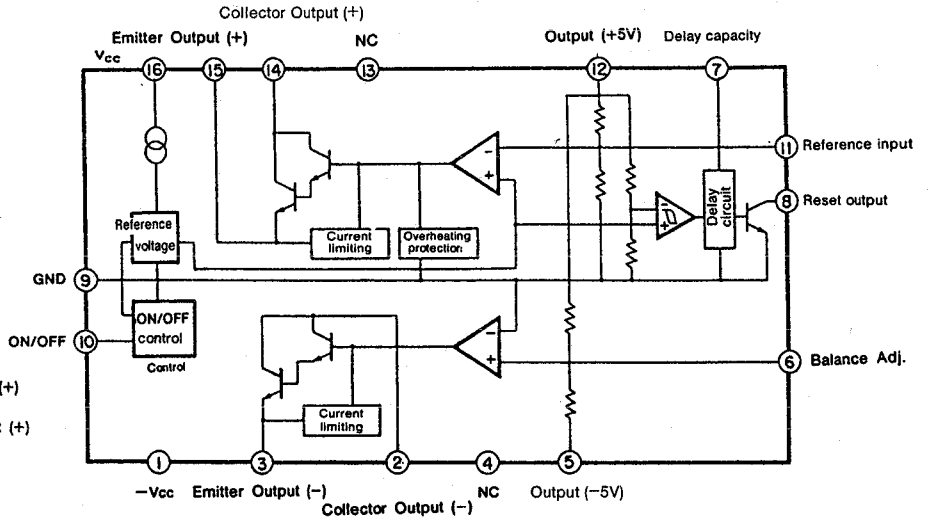
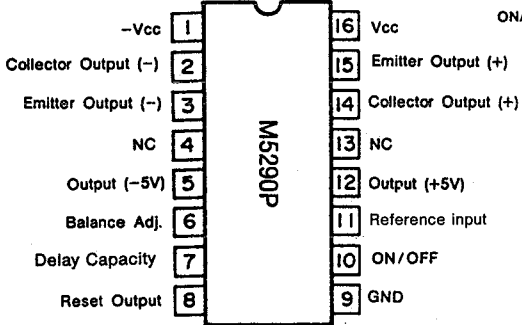
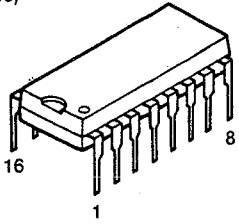

ICP-N15 (IC101~103) IC Protector



BA15218 (IC501)

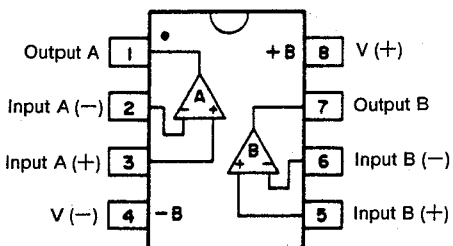
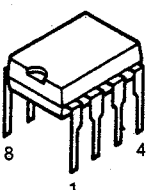

PST529C (IC251)

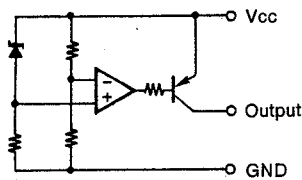
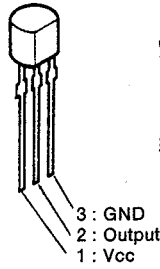

3 : GND
2 : Output
1 : Vcc

CD PLAYER SECTION

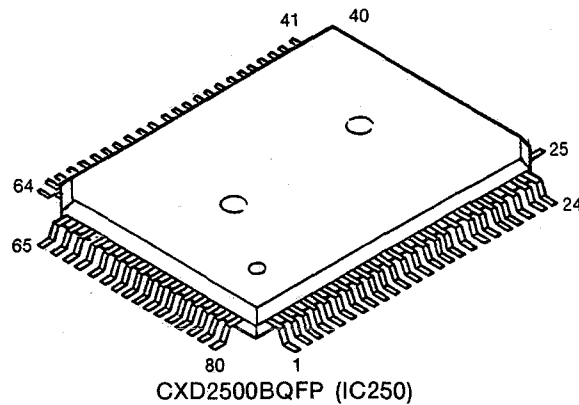

● Pin Function Table

Pin no.	Pin symbol	I/O	Pin description
1	FOK	I	Focus OK input pin. Used in SENS output and the servo auto sequencer.
2	FSW	O Z,0	Output filter switching output of the spindle motor.
3	MON	O 1,0	On-off control output of the spindle motor.
4	MDP	O 1,Z,0	Servo control of the spindle motor.
5	MDS	O 1,Z,0	Servo control of the spindle motor.
6	LOCK	O 1,0	Samples GFS at 460 Hz. When GFS is "H", H is output. L is output when there is "L", 8 times in succession.
7	NC	—	
8	VCOO	O 1,0	Oscillation circuit output for analog EFM PLL.
9	VCOI	I	Oscillation circuit output for analog EFM PLL. $f_{\text{LOCK}} = 8.6436 \text{ MHz}$.
10	TEST	I	Test pin, always grounded.
11	PDO	O 1,Z,0	For charge pump used with analog EFM PLL.
12	V _{SS}		Ground
13	NC	—	
14	NC	—	
15	NC	—	
16	VPCO	O 1,Z,0	PLL charge pump output used for vari-pitch.
17	VCKI	O	Clock input f_{CENTER} from the external VCO for varipitch equals 16.9344 MHz.
18	FILO	O Analog	Filter output (slave = digital PLL) for master PLL.
19	FILI	I	Filter input for master PLL.
20	PCO	O 1,Z,0	Charge pump output for master PLL.
21	AV _{SS}		Analog ground.
22	CLTV	I	VCO control voltage input for master.
23	AV _{DD}		Analog supply (+5 V)
24	RF	I	EFM signal input
25	TEST2	I	Grounded
26	TEST3	I	Grounded
27	ASYO	O 1,0	EFM full-swing output. (L = V _{SS} , H = V _{DD})
28	TEST4	I	Grounded
29	NC	—	
30	PSSL	I	Switching input for the audio data output mode. Serial output with "L" and parallel output with "H".
31	WDCK	O 1,0	D/A interface for 48-bit slot. Word clock $f = 2F_s$.
32	LRCK	O 1,0	D/A interface for 48-bit slot. LR clock $f = F_s$.
33	V _{DD}		Supply (+5 V)

CD PLAYER SECTION

Pin no.	Pin symbol	I/O		Pin description
34	DA16	O	1,0	DA16 (MSB) output when PSSL = 1. Serial data of the 48-bit slot when PSSL = 0. (2s' COMP, MSB first.)
35	DA15	O	1,0	DA15 output when PSSL = 1. Bit clock of the 48-bit slot when PSSL = 0.
36	DA14	O	1,0	DA14 output when PSSL = 1. Serial data of the 64-bit slot when PSSL = 0. (2s' COMP, LSB first.)
37	DA13	O	1,0	DA13 output when PSSL = 1. Bit clock of the 64-bit slot when PSSL = 0.
38	DA12	O	1,0	DA12 output when PSSL = 1. LR clock of the 64-bit slot when PSSL = 0.
39	DA11	O	1,0	DA11 output when PSSL = 1. GTOP output when PSSL = 0.
40	DA10	O	1,0	DA10 output when PSSL = 1. XUGF output when PSSL = 0.
41	DA09	O	1,0	DA09 output when PSSL = 1. XPLCK output when PSSL = 0.
42	DA08	O	1,0	DA08 output when PSSL = 1. GFS output when PSSL = 0.
43	DA07	O	1,0	DA07 output when PSSL = 1. RFCK output when PSSL = 0.
44	DA06	O	1,0	DA06 output when PSSL = 1. C2P0 output when PSSL = 0.
45	DA05	O	1,0	DA05 output when PSSL = 1. XRAOF output when PSSL = 0.
46	DA04	O	1,0	DA04 output when PSSL = 1. MNT3 output when PSSL = 0.
47	DA03	O	1,0	DA03 output when PSSL = 1. MNT2 output when PSSL = 0.
48	DA02	O	1,0	DA02 output when PSSL = 1. MNT1 output when PSSL = 0.
49	DA01	O	1,0	DA01 output when PSSL = 1. MNT0 output when PSSL = 0.
50	APTR	O	1,0	Control output for aperture correction. "H" with Rch.
51	APTL	O	1,0	Control output for aperture correction. "H" with Lch.
52	Vss			Ground
53	XTAI	I		16.9344 MHz x'tal oscillator circuit input. Or 33.8688 MHz input.
54	XTAO	O	1,0	16.9344 MHz x'tal oscillator circuit input.
55	XTSL	I		X'tal selection input pin. "L" when the x'tal is 16.9344 MHz and "H" when the x'tal is 33.8688 MHz.
56	FSTT	O	1,0	2/3 frequency division output of pins 53 and 54. Does not change with vari-pitch.
57	C4M	O	1,0	4.2336 MHz output. Changes simultaneously when varypitch is applied.
58	C16M	O	1,0	16.9344 MHz output. Changes simultaneously when varypitch is applied.
59	MD2	I		Digital-Out on/off control. H when on and L when off.
60	DOUT	O	1,0	Digital-out output pin.
61	EMPH	O	1,0	When the playback disc has emphasis, "H" is output. "L" is output when there is no emphasis.
62	WFCK	O	1,0	WFCK (Write Frame Clock) output.
63	SCOR	O	1,0	"H" output when either sub code sync S0 or S1 is detected.
64	SBSO	O	1,0	Sub P through W serial output.
65	EXCK	I		Clock input for SBSO read-out use.
66	SQSO	O	1,0	SubQ 80 bit and PCM peak level data 16-bit output.
67	SQCK	I		Clock input for SQSO read-out use.
68	MUTE	I		Mute L is cancelled with H.
69	SENS	—	1,Z,0	SENS output. Output to CPU.
70	XRST	I		System set. Reset with "L".
71	DATA	I		Serial data input from CPU.
72	XLAT	I		Latch input from CPU. Latches serial data on the fall.
73	VDD			Supply (+5 V)
74	CLOK	I		Serial data transfer clock input from CPU.
75	SEIN	I		Sense input from SSP.
76	CNIN	O		Count signal input of number of track jumps.
77	DATO	O	1,0	Serial data output to SSP.
78	XLTO	O	1,0	Serial data latch output to SSP. Latches on the fall.
79	CLKO	O	1,0	Serial data transfer clock output to SSP.
80	MIRR	I		Mirror signal input. Used in jumps of 128 tracks or more with an auto sequencer.

CD PLAYER SECTION

LC78835 (IC300)

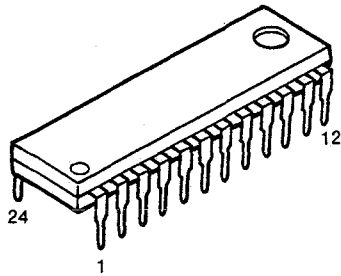

Pin Location

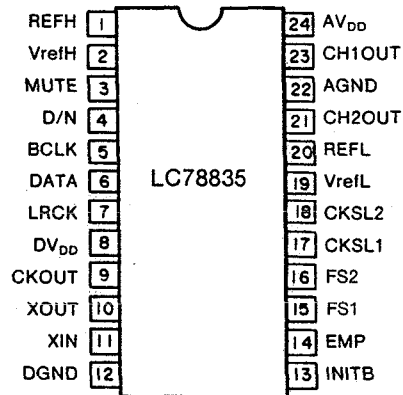

Block Diagram

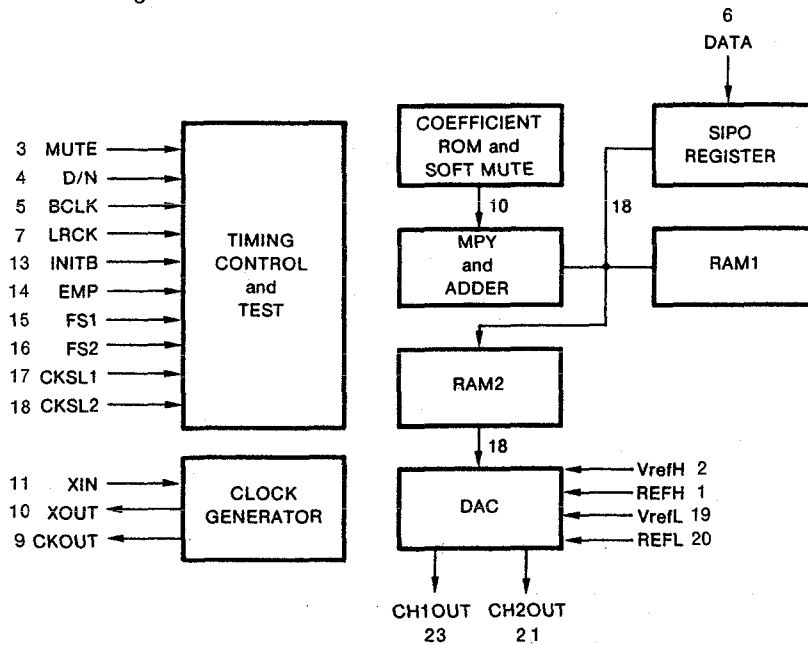

CD PLAYER SECTION

● Pin Description

1	REFH	Reference voltage "H" pin Normally connected to AGND via a capacitor															
2	VrefH	Reference voltage "H" input pin															
3	MUTE	Muting signal input pin Soft muting on at "H"															
4	D/N	Standard/high speed operation mode switching pin High speed operation at "H", standard operation at "L"															
5	BCLK	Bit clock input pin															
6	DATA	Digital audio data input pin Input with 2's compliment, MSB first															
7	LRCK	LR clock input pin CH1 at "H" and CH2 at "L"															
8	DV _{DD}	Digital system power supply pin															
9	CKOUT	Clock output pin At 392 fs: Clock of 196 fs At times other than 392 fs: Clock of XIN frequency															
10	XOUT	Crystal oscillator output pin (system clock output pin)															
11	XIN	Crystal oscillator output pin (system clock input pin)															
12	DGND	Digital system ground pin															
13	INITB	Initialization signal input pin Initialization performed at "L"															
14	EMB	De-emphasis filter on/off switching pin On at "H" and off at "L"															
15	FS1	Selection pins for the 32 kHz/44.1 kHz/48 kHz modes of the de-emphasis filter															
16	FS2	<table border="1"> <tr> <td>FS1</td> <td>L</td> <td>H</td> <td>H</td> <td>L</td> </tr> <tr> <td>FS2</td> <td>L</td> <td>L</td> <td>H</td> <td>H</td> </tr> <tr> <td>fs</td> <td colspan="2">44.1 kHz</td> <td>32 kHz</td> <td>48 kHz</td> </tr> </table>	FS1	L	H	H	L	FS2	L	L	H	H	fs	44.1 kHz		32 kHz	48 kHz
		FS1	L	H	H	L											
FS2	L	L	H	H													
fs	44.1 kHz		32 kHz	48 kHz													
17	CKSL1	System clock selection pins															
18	CKSL2	<table border="1"> <tr> <td>CKSL1</td> <td>CKSL2</td> <td>System Clock</td> </tr> <tr> <td>L</td> <td>L</td> <td>384 fs</td> </tr> <tr> <td>L</td> <td>H</td> <td>392 fs</td> </tr> <tr> <td>H</td> <td>L</td> <td>448 fs</td> </tr> <tr> <td>H</td> <td>H</td> <td>512 fs</td> </tr> </table>	CKSL1	CKSL2	System Clock	L	L	384 fs	L	H	392 fs	H	L	448 fs	H	H	512 fs
		CKSL1	CKSL2	System Clock													
		L	L	384 fs													
		L	H	392 fs													
H	L	448 fs															
H	H	512 fs															
19	VrefL	Reference voltage "L" input pin															
20	REFL	Reference voltage "L" pin Normally connected to AGND via a capacitor															
21	CH2OUT	CH2 analog output pin															
22	AGND	Analog system ground pin															
23	CH1OUT	CH1 analog output pin															
24	AV _{DD}	Analog system power supply pin															

● Transistors

2SA934 (Q)
2SC2060 (Q)

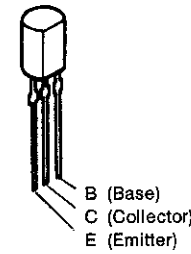

2SB1185 (E/F)

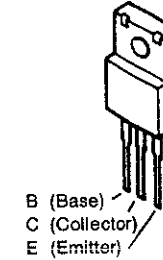

2SA933S (S)
2SD2144S
2SC1740S (S)

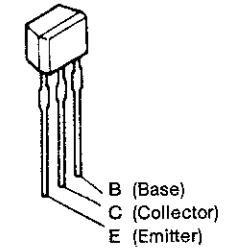

DTA114ES } PNP Type
DTA114TS }
DTC114ES } NPN Type
DTC144ES }

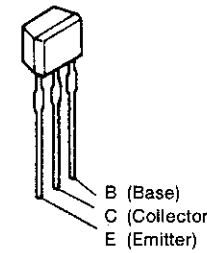

PNP Type

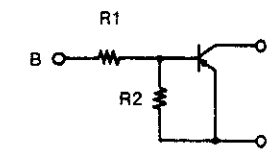

NPN Type

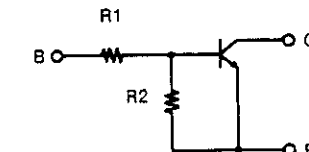

	R1	R2
DTA114ES	10k ohm	10k ohm
DTA114TS	10k ohm	—

	R1	R2
DTC114ES	10k ohm	10k ohm
DTC144ES	47k ohm	47k ohm

● Diodes

1SS254



1SR35-200A

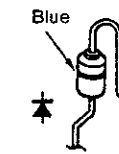

1SS198

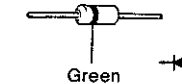

HZS6B-1
HZS6B-2

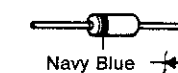

● LED ASS'Y

SLR-34MC70F (Green)

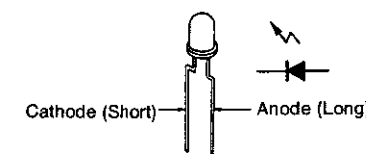

μPD75517G-197-3B9 (IC200)

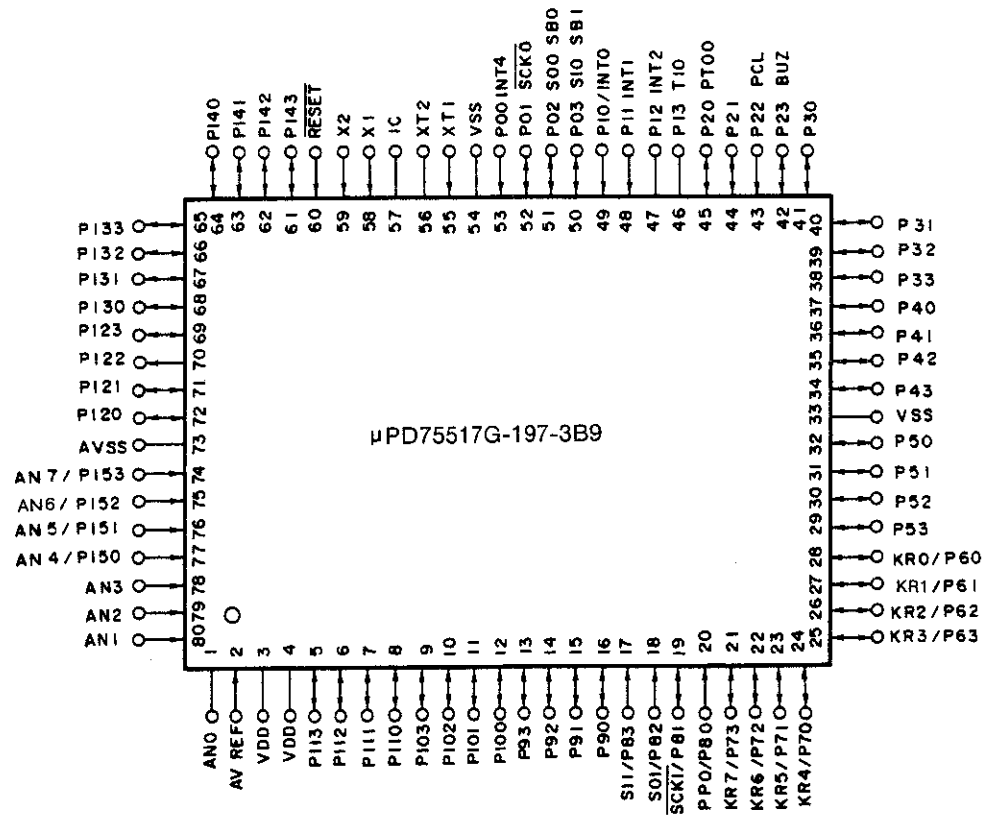
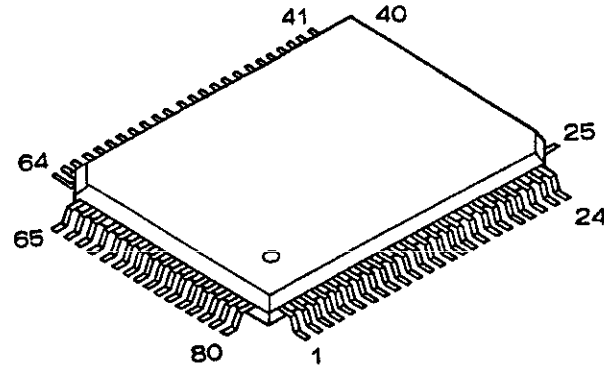

● Pin Description

No.	Port Name	Function Name	Function	No.	Port Name	Function Name	Function
1	AN0	NC	Ground (In)	42	P23/BUZ	PSVCDATA OUT	Servo control signal and data output for D and F
2	AVref	NC	Ground (In)	43	P22/PCL	PSVCXLT OUT	Servo control signal latch output
3	VDD		5 V	44	P21	PSVCLK	Servo control signal and clock output for D and F
4	VDD		5 V	45	P20/PT00	PLASER OUT	Laser on/off control output
5	P113	FBS	Open (Out)	46	P13/T10	PSENSE IN	Servo condition detection signal input
6	P112	PLYON	PLAY display (Open)	47	P12/INT2	PGFS IN	Rotation sync signal input from DSP
7	P111	PAUTO	AUTO and OFF display (Open)	48	P11/INT1	PSCOR IN	Sub code sync signal input
8	P110	PDPLAY	PLAY display (LED control)	49	P10/INT0	RXD	Denon bus in
9	P103	XRST OUT	Reset signal for DSP	50	PO3/SIO	PSUBQ IN	Sub code data input
10	P102	POWER OFF OUT	Output for power on/off control (Open)	51	PO2/SO0	NC	Open (Out)
11	P101	DIGITAL OFF OUT	Output for digital on/off control (Open)	52	PO1/SCK0	PSQCK OUT	Clock output for sub code reading
12	P100	STANDBY OUT	Output for power on/off control	53	PO0/INT4	50/60 IN	50 Hz/60 Hz input
13	P93	PINITIAL	Test pin (Open)	54	VSS		Ground
14	P92	PEDIT	Test pin (Open)	55	XT1	NC	Ground
15	P91	PSEARCH	Test pin (Open)	56	XT2	NC	Open
16	P90	PDOUT	Test pin (Open)	57	IC	NC	Ground
17	P83/SI1	NC	Ground (In)	58	X1		4 MHz ceramic lock
18	P82/SO1	SO1	Data for LCD	59	X2		4 MHz ceramic lock
19	P81/SCK1	SCK1	Clock for LCD	60	RESET		Reset signal input
20	P80/PPO	NC	Ground (In)	61	P143	PFOK IN	Focus OK signal input
21	P73/KR7	KS3 OUT	Key scan output	62	P142	PSWOP IN	Loader open position detection
22	P72/KR6	KS2 OUT	Key scan output	63	P141	PSWCL IN	Loader close position detection
23	P71/KR5	KS1 OUT	Key scan output	64	P140	PSWPM IN	Pickup inner track position detection
24	P70/KR4	KS0 OUT	Key scan output	65	P133	PMVCL OUT	Loader drive signal
25	P63/KR3	KS7 OUT	Key scan output (Open)	66	P132	PMVOP OUT	Loader drive signal
26	P62/KR2	KS6 OUT	Key scan output (Open)	67	P131	D. MUTE OUT	Mute output for the LSI
27	P61/KR1	KS5 OUT	Key scan output (Open)	68	P130	TXD	Denon bus out
28	P60/KR0	KS4 OUT	Key scan output (Open)	69	P123	PDFLATCH OUT	Latch output for D and F (Open)
29	P53	KS8 OUT	Key scan output (Open)	70	P122	A. MUTE OUT	Audio mute output
30	P52	KS9 OUT	Key scan output (Open)	71	P121	PEMPHA OUT	Signal output with emphasis control signal present (Open)
31	P51	G1	Open (Out)	72	P120	PDIRC OUT	Servo control signal output
32	P50	G2	Open (Out)	73	AVSS	NC	Ground
33	VSS		Ground (In)	74	AN7/P153	KR0 IN	Key return input
34	P43	CD ON/OFF IN	Input for digital on/off control	75	AN6/P152	KR1 IN	Key return input
35	P42	A.P. SEL IN	Selects the auto power on/off function	76	AN5/P151	KR2 IN	Key return input
36	P41	NC	Open	77	AN4/P150	KR3 IN	Key return input
37	P40	RESET 2	+5 V detection input	78	AN3	NC	Ground (In)
38	P33	PLCDOFF OUT	INH for LCD (Open)	79	AN2	NC	Ground (In)
39	P32	PLCDCE OUT	CE for LCD (Open)	80	AN1	NC	Ground (In)
40	P31	G3	Open (Out)				
41	P30	G4	Open (Out)				

MICROPROCESSOR PERIPHERAL WIRING DIAGRAM

CD PLAYER SECTION

1 2 3 4 5 6 7 8

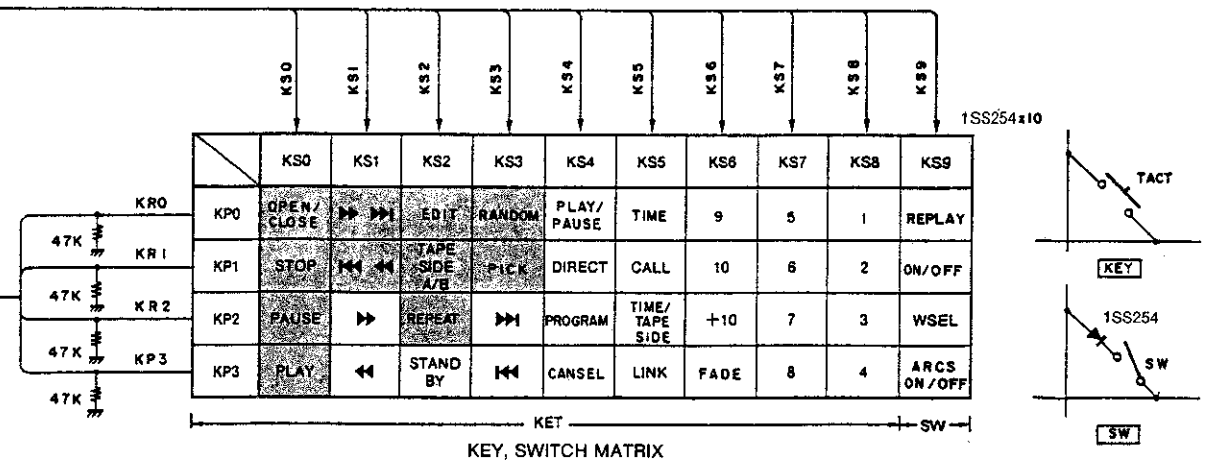
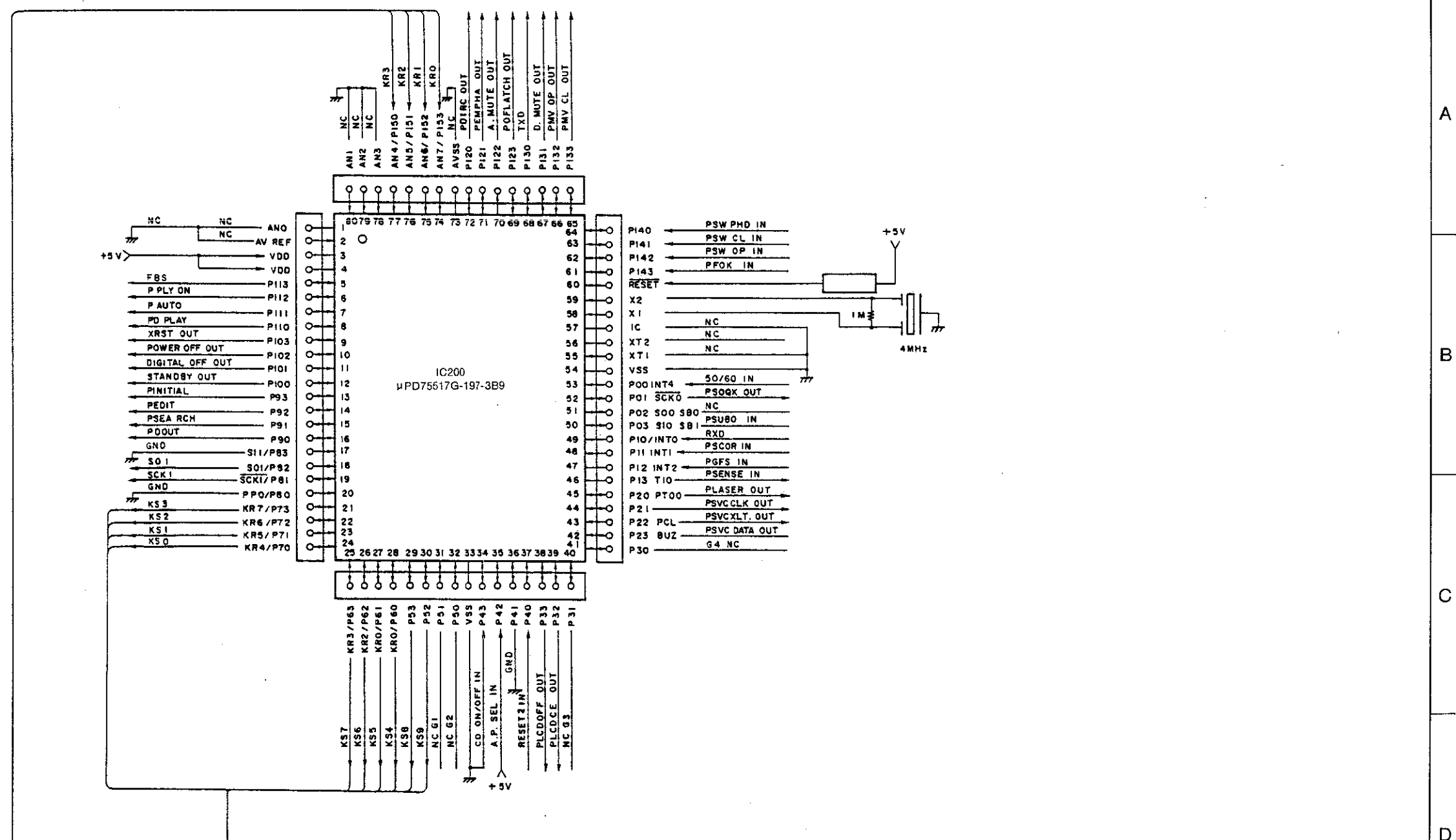

KEY, SWITCH MATRIX

(Item using this device [shaded box])

A
B
C
D
E

CD PLAYER SECTION

PRINTED WIRING BOARD

Component Side 2U-2557 CD UNIT ASS'Y

2U-2557	
1	Main Unit
2	Display Unit
3	Connector Unit

A

B

C

D

E

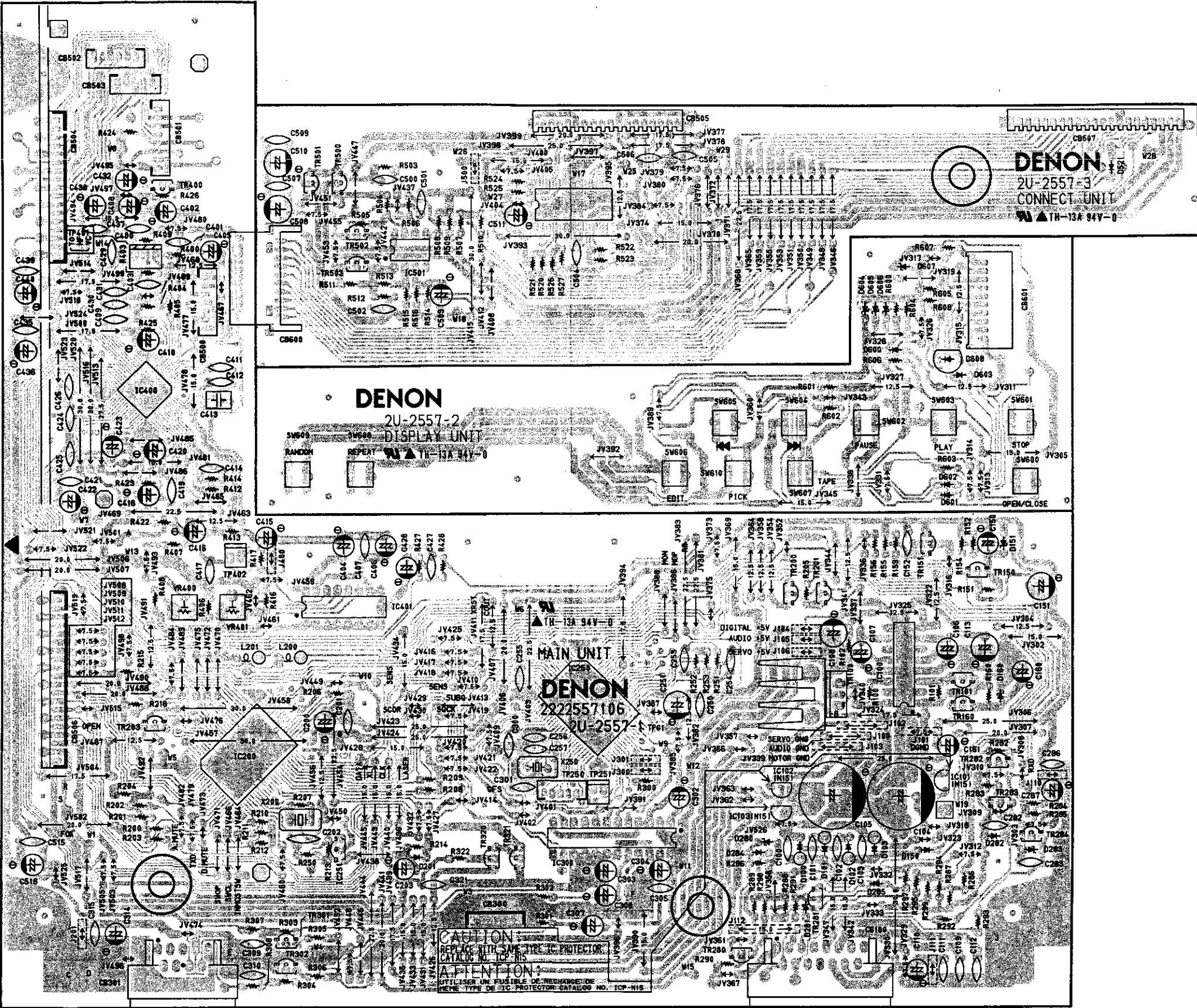

1 2 3 4 5 6 7 8

Pattern Side

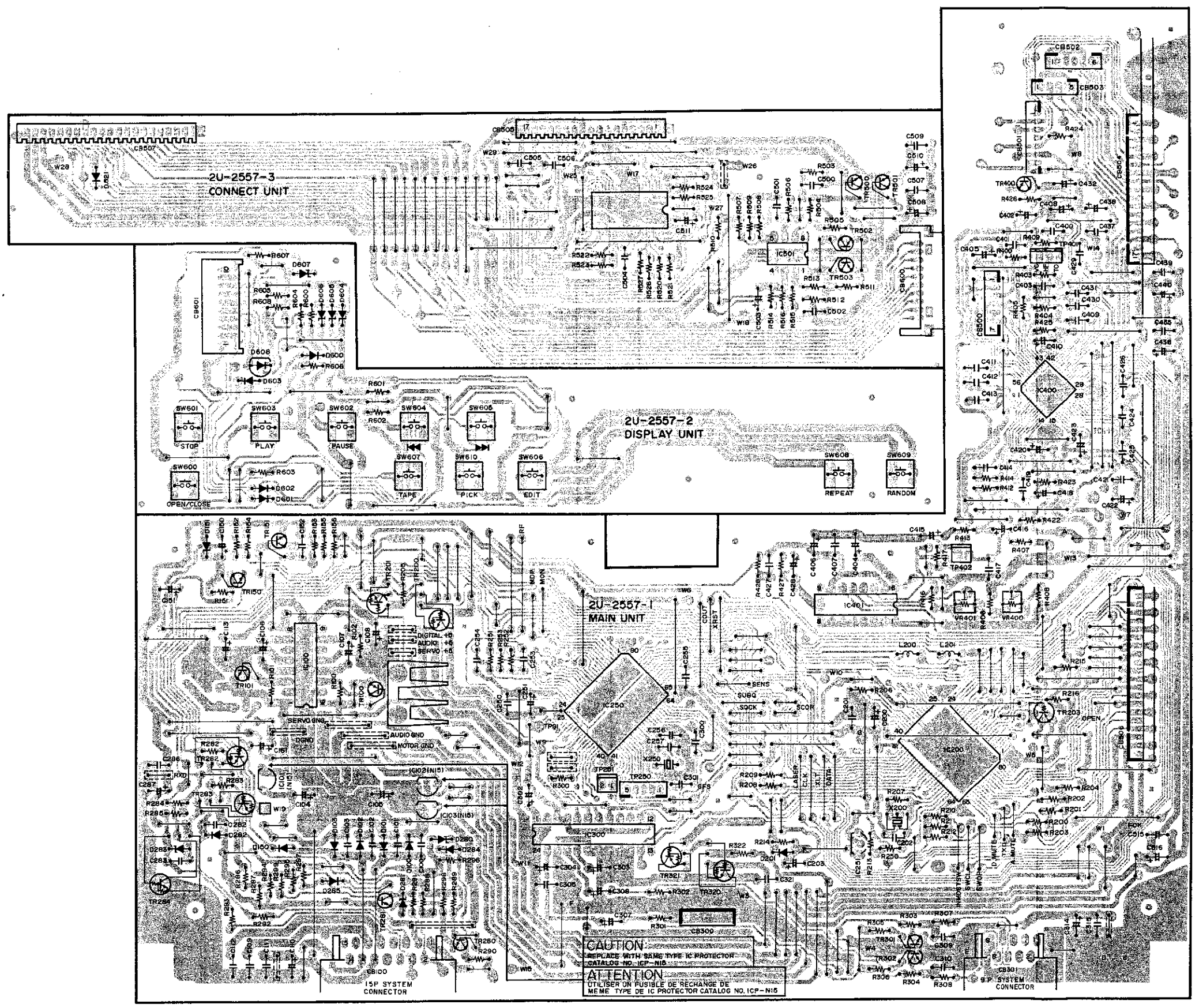

A
B
C
D
E

CD PLAYER SECTION

NOTE ON PARTS LIST

- Part indicated with the mark "⊙" are not always in stock and possibly to take a long period of time for supplying, or in some case supplying of part may be refused.
- When ordering of part, clearly indicate "1" and "1" (i) to avoid mis-supplying.
- Ordering part without stating its part number can not be supplied.
- Part indicated with the mark "★" is not illustrated in the exploded view.
- Not including Carbon Film ±5%, 1/4W Type in the P.W. Board parts list. (Refer to the Schematic Diagram for those parts.)

WARNING:

Parts marked with this symbol Δ have critical characteristics.
Use ONLY replacement parts recommended by the manufacturer.

Resistors

Ex.: RN 14K 2E 182 G FR
Type Shape and performance Power Resistance Allowable error Others

RD : Carbon Film	2E : 1/4W	F : ±1%	P : Pulse-resistant type
RC : Composition	2H : 1/2W	G : ±2%	NL : Low noise type
RS : Metallic oxide Film	3A : 1W	J : ±5%	NB : Non-burning type
RW : Winding	3D : 2W	K : ±10%	FR : Fuse-resistor
RN : Metal film	3F : 3W	M : ±20%	F : Lead wire forming
RK : Metal mixture	3H : 5W		

* Resistance

- 1 8 2 ⇒ 1800 ohm = 1.8 kohm
Indicates number of zeros after effective number
2-digit effective number
Units: ohm
- 1 R 2 ⇒ 1.2 ohm
1-digit effective number.
2-digit effective number, decimal point indicated by R.
Units: ohm
- * Capacity (electrolyte only)
2 2 R ⇒ 2200 μF
Indicates number of zeros after effective number.
2-digit effective number.
Units: μF
- 2 R 2 ⇒ 2.2 μF
1-digit effective number.
2-digit effective number, decimal point indicated by R.
Units: μF

Capacitors

Ex.: CE 04W 1H 2R2 M BP
Type Shape and performance Dielectric strength Capacity Allowable error Others

CE : Aluminum foil electrolyte	0J : 6.3V	F : ±1%	HS : High stability type
CA : Aluminum solid electrolyte	1A : 10V	G : ±2%	BP : Non-polar type
CS : Tantalum electrolyte	1C : 16V	J : ±5%	HR : Ripple-resistant type
CQ : Film	1E : 25V	K : ±10%	DL : For charge and discharge
CK : Ceramic	1V : 35V	M : ±20%	HF : For assuring high frequency
CC : Ceramic	1H : 50V	Z : +80%	U : UL part
CP : Oil	2A : 100V	-20%	C : CSA part
CM : Mica	2B : 125V	P : +100%	W : UL-CSA type
CF : Metallized	2C : 160V	-0%	F : Lead wire forming
CH : Metallized	2D : 200V	C : ±0.25pF	
	2E : 250V	D : ±0.5pF	
	2H : 500V	= : Others	
	2J : 630V		

* Capacity (except electrolyte)

- 2 R 2 ⇒ 2200pF = 2200 μF = 0.002 μF
(More than 2) Indicates number of zeros after effective number.
2-digit effective number.
Units: μF
- 2 2 1 ⇒ 220pF
(0 or 1) Indicates number of zeros after effective number.
2-digit effective number.
Units: pF
- When the dielectric strength is indicated in AC, "AC" is included after the dielectric strength value.

2U-2557 CD UNIT ASS'Y PARTS LIST

Ref. No.	Part No.	Part Name	Remarks	Ref. No.	Part No.	Part Name	Remarks
SEMICONDUCTORS GROUP				C151	254 4254 941	Electrolytic 100μF/16V	CE04W1C101M
IC100	263 0693 005	IC M5290P		C152	253 9030 963	BC Ceramic 0.01μF/25V	CK45-1E103K
IC101~103	268 0073 905	IC ICP-N15T	IC Protector 15 V	C200	254 4252 930	Electrolytic 100μF/10V	CE04W1A101M
IC200	262 1791 107	IC μPD75517GF-197-3B9	μ-com	C201,202	253 1181 904	Ceramic 0.01μF/50V	CK45F1H103Z
IC250	262 1819 005	IC CXD2500BQ		C203	254 4254 909	Electrolytic 10μF/16V	CE04W1C100M
IC251	263 0652 907	IC PST529C		C250	253 1181 904	Ceramic 0.01μF/50V	CK45F1H103Z
IC300	262 1824 003	IC LC78835		C251	254 4250 932	Electrolytic 220μF/6.3V	CE04W0J221M
IC400	263 0821 000	IC HA12158		C253	256 1034 937	Metalized 0.047μF/50V	CF93A1H473J
IC500	263 0805 903	IC BA6296FP		C254	253 1180 947	Ceramic 1500pF/50V	CK45B1H152K
IC501	263 0565 007	IC BA15218		C255	253 1181 904	Ceramic 0.01μF/50V	CK45F1H103Z
TR100	272 0083 004	Transistor 2SB1185(E/F)		C256	253 4535 939	Ceramic 3pF/50V	CC45SL1H030C
TR150	273 0195 908	Transistor 2SC2060(Q)		C257	253 4535 955	Ceramic 5pF/50V	CC45SL1H050C
TR151	273 0303 910	Transistor 2SC1740S(S)		C282,283	253 1179 987	Ceramic 470pF/50V	CK45B1H471K
TR200,201	269 0020 906	Transistor DTC114ES	Built in Resistor	C286	253 1181 904	Ceramic 0.01μF/50V	CK45F1H103Z
TR203	269 0080 904	Transistor DTA114TS	Built in Resistor	C301	253 4536 983	Ceramic 22pF/50V	CC45SL1H220J
TR280,281	271 0192 905	Transistor 2SA933S(S)		C302,303	254 4254 909	Electrolytic 10μF/16V	CE04W1C100M
TR282~284	269 0040 902	Transistor DTC144ES	Built in Resistor	C304	254 4250 932	Electrolytic 220μF/6.3V	CE04W0J221M
TR301,302	274 0160 907	Transistor 2SD2144STPU		C305	253 1181 904	Ceramic 0.01μF/50V	CK45F1H103Z
TR320	269 0046 906	Transistor DTA114ES	Built in Resistor	C307,308	254 4252 930	Electrolytic 100μF/10V	CE04W1A101M
TR321	269 0020 906	Transistor DTC114ES	Built in Resistor	C309,310	253 4538 949	Ceramic 100pF/50V	CC45SL1H101J
TR400	271 0192 905	Transistor 2SA933S(S)		C400	253 1180 921	Ceramic 1000pF/50V	CK45B1H102K
TR500	273 0195 908	Transistor 2SC2060(Q)		C401	253 1181 904	Ceramic 0.01μF/50V	CK45F1H103Z
TR501	271 0271 907	Transistor 2SA934(Q)		C402	254 4252 927	Electrolytic 47μF/10V	CE04W1A470M
TR502	273 0195 908	Transistor 2SC2060(Q)		C403	253 4538 965	Ceramic 120pF/50V	CC45SL1H121J
TR503	271 0271 907	Transistor 2SA934(Q)		C404	254 4254 909	Electrolytic 10μF/16V	CE04W1C100M
D100~103	276 0553 905	Diode 1SR35-200A		C405	254 4305 942	Electrolytic 0.47μF/50V	CE04W1HR47M(SRE)
D150	276 0531 901	Diode 1SS254		C408	254 4252 930	Electrolytic 100μF/10V	CE04W1A101M
D151	276 0462 915	Zener Diode HZS6B-2	6 V	C409	253 9031 962	BC Ceramic 2700pF/25V	CK45-1E272K
D201	276 0531 901	Diode 1SS254		C410	254 4254 909	Electrolytic 10μF/16V	CE04W1C100M
D280~283	276 0462 902	Zener Diode HZS6B-1	6 V	C411	253 9035 942	BC Ceramic 0.056μF/25V	CK45-1E563K
D284,285	276 0503 900	Diode 1SS198		C412	253 9035 926	BC Ceramic 0.027μF/25V	CK45-1E273K
D600~603	276 0531 901	Diode 1SS254		C413	256 1034 995	Metalized 0.15μF/50V	CF93A1H154J
D604~607	276 0462 902	Zener Diode HZS6B-1	6 V	C414	253 1179 974	Ceramic 390pF/50V	CK45B1H391K
D608	393 9483 902	LED SLR-34MC70F120 G	Green	C415	254 4252 901	Electrolytic 22μF/10V	CE04W1A220M
RESISTORS GROUP (Not included Carbon Film ±5%, 1/4W Type. Refer to the Schematic Diagram for those Parts.)				C416	254 4260 919	Electrolytic 0.22μF/50V	CE04W1HR22M
VR400	211 6087 931	Semi Fixed VR 4.7k ohm	V06PB472	C417	253 1180 921	Ceramic 1000pF/50V	CK45B1H102K
CAPACITORS GROUP				C418	254 4260 919	Electrolytic 0.22μF/50V	CE04W1HR22M
C104	254 4254 792	Electrolytic 2200μF/16V	CE04W1C222MC	C419	253 9031 988	BC Ceramic 5600pF/25V	CK45-1E562K
C105	254 4255 704	Electrolytic 3300μF/16V	CE04W1C332MC	C420	254 4260 948	Electrolytic 1μF/50V	CE04W1H010M
C106	254 4260 948	Electrolytic 1μF/50V	CE04W1H010M	C421	253 1181 904	Ceramic 0.01μF/50V	CK45F1H103Z
C107	254 4260 964	Electrolytic 3.3μF/50V	CE04W1H3R3M	C422	254 4252 930	Electrolytic 100μF/10V	CE04W1A101M
C108	254 4250 932	Electrolytic 220μF/6.3V	CE04W0J221M	C423	254 4254 909	Electrolytic 10μF/16V	CE04W1C100M
C109	253 1181 904	Ceramic 0.01μF/50V	CK45F1H103Z	C424,425	253 1181 904	Ceramic 0.01μF/50V	CK45F1H103Z
C110	254 4260 948	Electrolytic 1μF/50V	CE04W1H010M	C426	253 1180 921	Ceramic 1000pF/50V	CK45B1H102K
C111,112	253 1181 904	Ceramic 0.01μF/50V	CK45F1H103Z	C427	253 1181 904	Ceramic 0.01μF/50V	CK45F1H103Z
C150	254 4260 948	Electrolytic 1μF/50V	CE04W1H010M	C428	254 4260 935	Electrolytic 0.47μF/50V	CE04W1HR47M
C200	254 4252 930	Electrolytic 100μF/10V	CE04W1A101M	C429	253 9030 976	BC Ceramic 0.015μF/25V	CK45-1E153K
C201,202	253 1181 904	Ceramic 0.01μF/50V	CK45F1H103Z	C430	253 9030 921	BC Ceramic 2200pF/25V	CK45-1E222K
C203	254 4254 909	Electrolytic 10μF/16V	CE04W1C100M	C431	253 9030 992	BC Ceramic 0.033μF/25V	CK45-1E333K
C250	253 1181 904	Ceramic 0.01μF/50V	CK45F1H103Z	C432	254 4254 909	Electrolytic 10μF/16V	CE04W1C100M
C251	254 4250 932	Electrolytic 220μF/6.3V	CE04W0J221M	C435	253 1181 904	Ceramic 0.01μF/50V	CK45F1H103Z
C253	256 1034 937	Metalized 0.047μF/50V	CF93A1H473J	C436	254 4252 930	Electrolytic 100μF/10V	CE04W1A101M
C254	253 1180 947	Ceramic 1500pF/50V	CK45B1H152K	C500	253 9031 988	BC Ceramic 5600pF/25V	CK45-1E562K
C255	253 1181 904	Ceramic 0.01μF/50V	CK45F1H103Z	C501	253 1181 904	Ceramic 0.01μF/50V	CK45F1H103Z
C256	253 4535 939	Ceramic 3pF/50V	CC45SL1H030C	C502	253 9030 989	BC Ceramic 0.022μF/25V	CK45-1E223K
C257	253 4535 955	Ceramic 5pF/50V	CC45SL1H050C	C503	254 4260 964	Electrolytic 3.3F/50μV	CE04W1H3R3M
C282,283	253 1179 987	Ceramic 470pF/50V	CK45B1H471K	C504	253 9039 906	BC Ceramic 0.1μF/25V	CK45-1E104Z
C286	253 1181 904	Ceramic 0.01μF/50V	CK45F1H103Z				

CD PLAYER SECTION

Ref. No.	Part No.	Part Name	Remarks	Qty
C507	253 9039 906	BC Ceramic 0.1μF/25V	CK45=1E104Z	
C508	254 4254 941	Electrolytic 100μF/16V	CE04W1C101M	
C509	253 9039 906	BC Ceramic 0.1μF/25V	CK45=1E104Z	
OTHERS GROUP				
	—	(P.W.Board)		(1)
	212 5604 910	Tact Switch		11
X200	399 0201 903	Ceramic Vibrator	EFOEC4004T4	1
X250	399 0200 904	Ceramic Vibrator	CSA16.93MX	1
CB100	204 8284 022	15 P System Socket		1
CB301	204 8284 035	9 P System Socket		1
CB500	205 0343 074	7 P Conn. Base(KR-PH)		1
CB501	205 0343 087	8 P Conn. Base(KR-PH)		1
CB502	205 0343 061	6 P Conn. Base(KR-PH)		1
CB503	205 0343 058	5 P Conn. Base(KR-PH)		1
CB504	205 0806 029	17 P Conn. Base		1
CB505	205 0805 020	17 P Conn. Socket		1
CB506	205 0806 032	20 P Conn. Base		1
CB507	205 0805 033	20 P Conn. Socket		1
CB600	205 0726 099	10 P Bottom Socket		1
CB601	205 0727 098	10 P Bottom Plug		1
TP401	205 0190 036	3 P NH Conn. Base		1

CD PLAYER SECTION

WIRING DIAGRAM

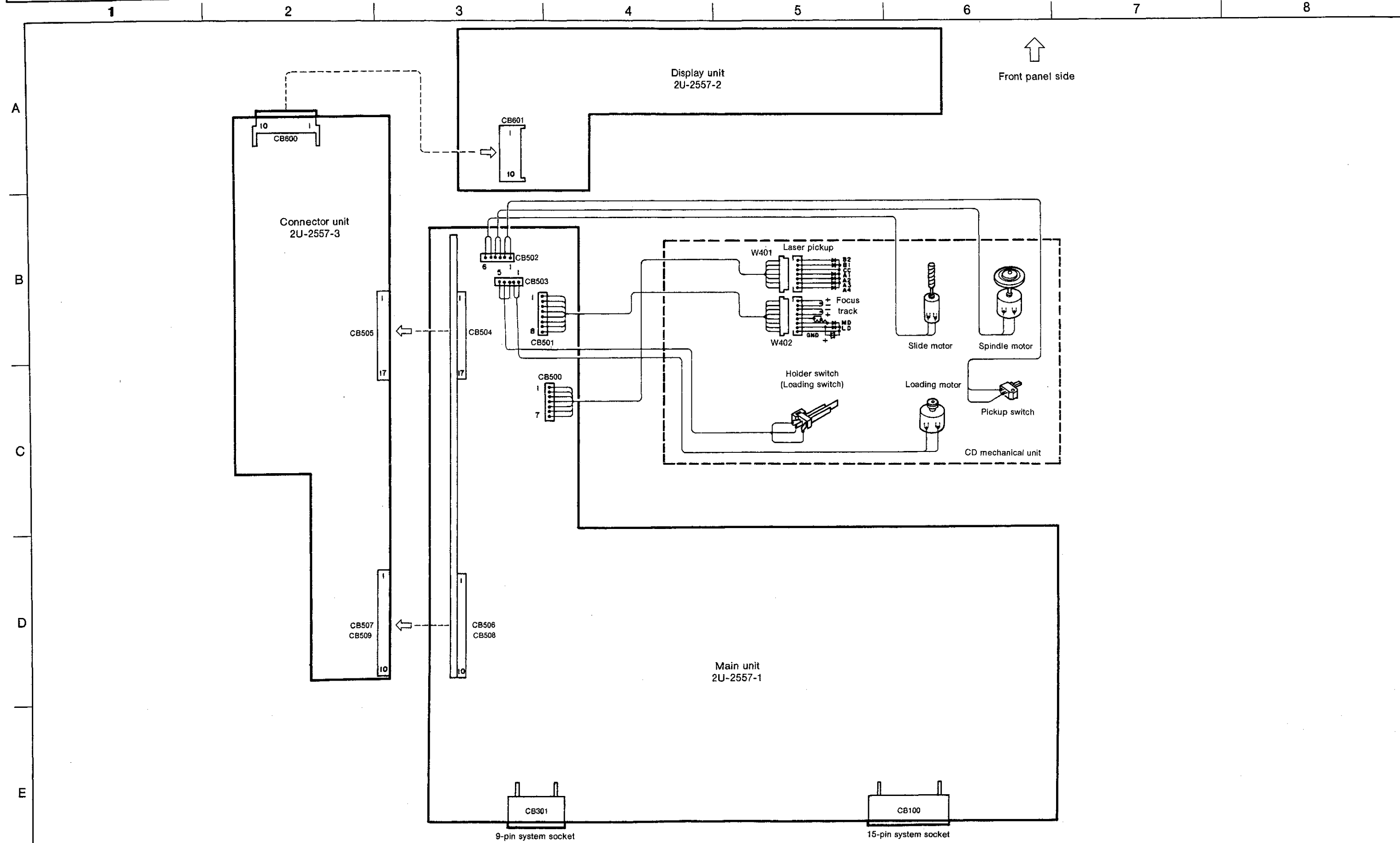

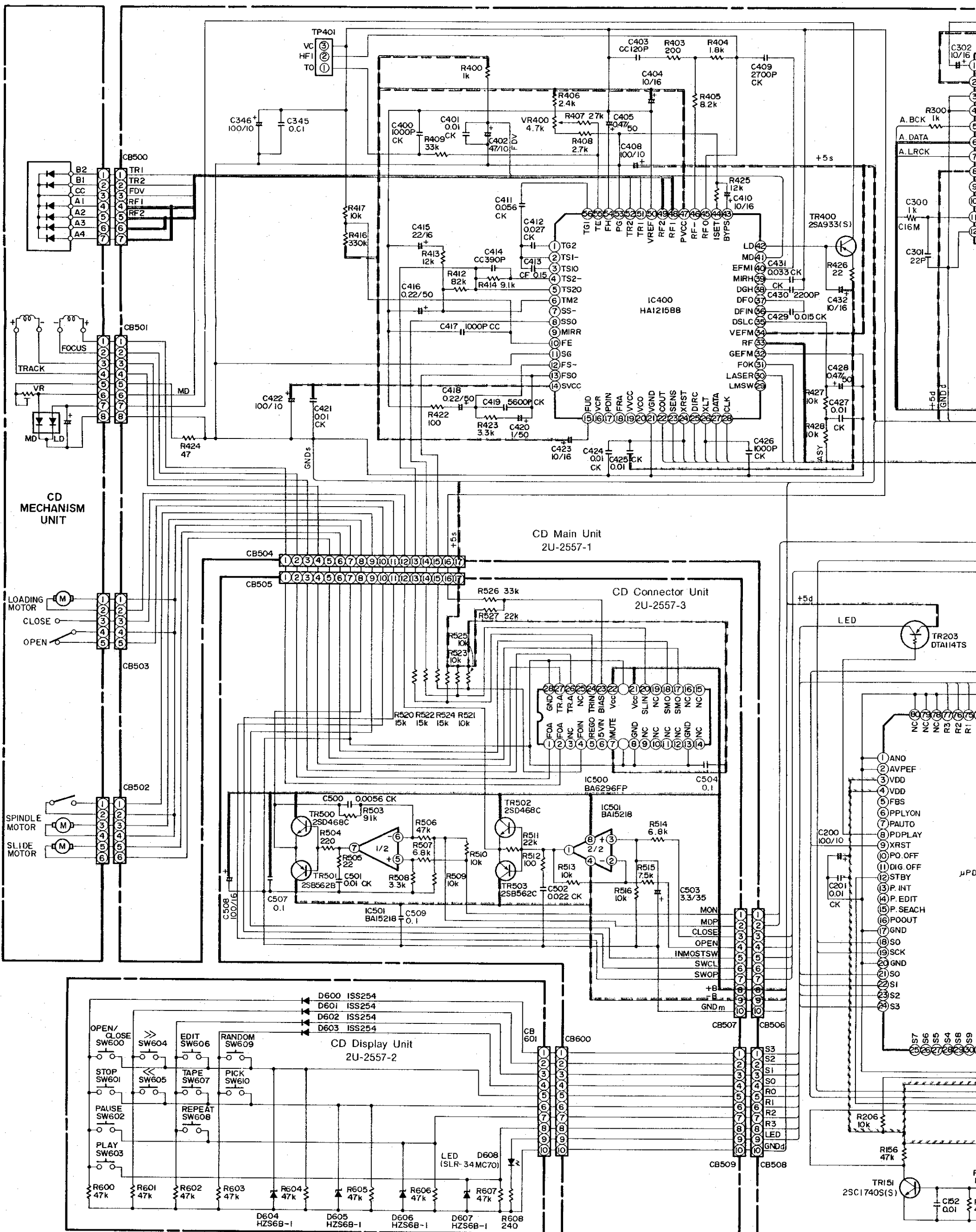

——— Signal Line
 ——— +5V Line (Switched)
 ——— -5 Line (Unswitched)

——— + B Line
 ——— - B Line

WARNING:
 Parts marked with this symbol Δ have critical characteristics.
 Use ONLY replacement parts recommended by the manufacturer.

CAUTION:
 Before returning the
 leakage current exc
 defective.
WARNING
 DO NOT return the

SCHEMATIC DIAGRAM

CD PLAYER SECTION

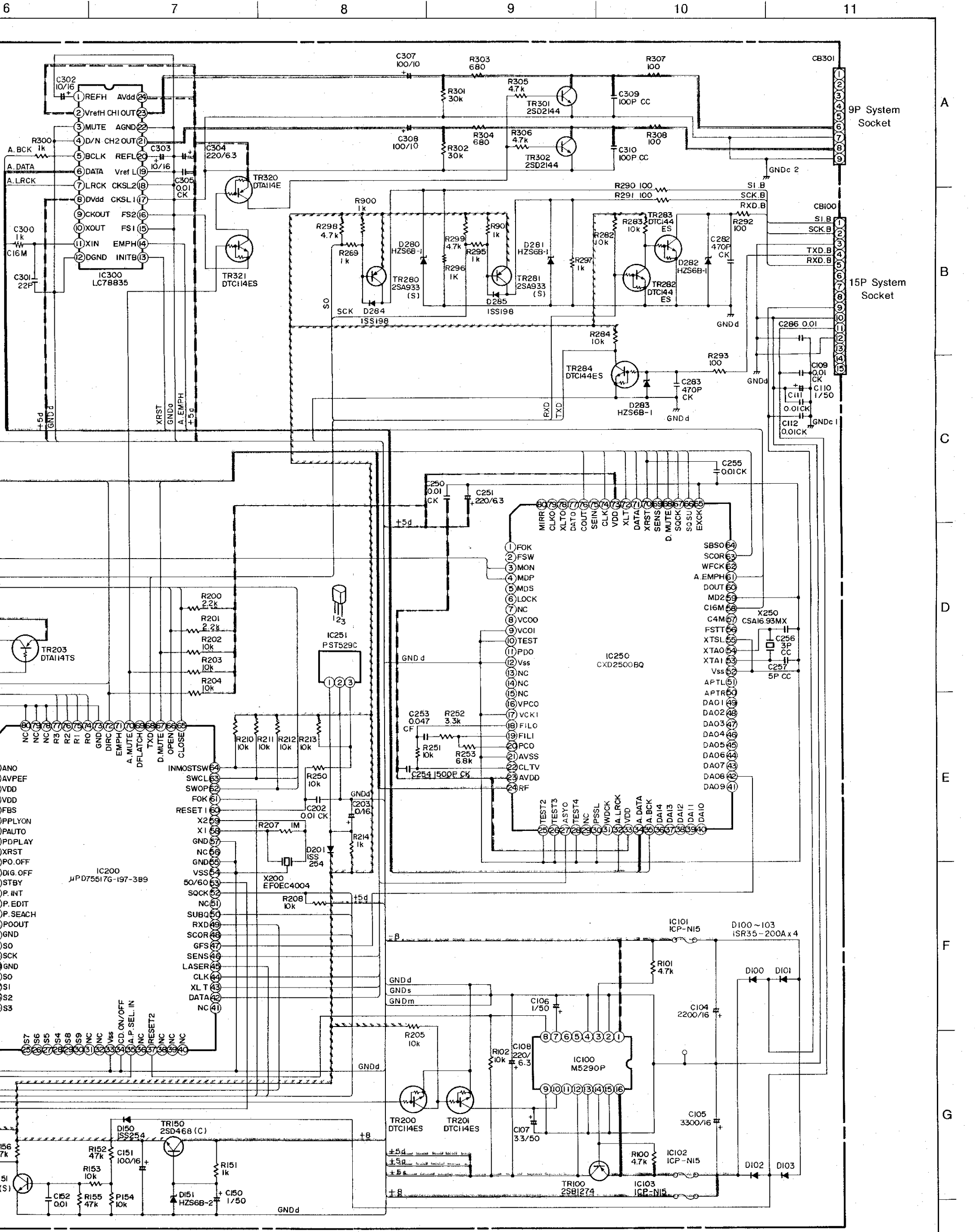

CAUTION:
Before returning the unit to the customer, make sure you make either (1) a leakage current check or (2) a line to chassis resistance check. If the leakage current exceeds 0.5 milliamps, or if the resistance from chassis to either side of the power cord is less than 240 Kohms, the unit is defective.

WARNING
DO NOT return the unit to the customer until the problem is located and corrected.

NOTES
ALL RESISTANCE VALUES IN OHM K=1,000 OHM M=1,000,000 OHM
ALL CAPACITANCE VALUES IN MICRO FARAD P=MICRO-MICRO FARAD
EACH VOLTAGE AND CURRENT ARE MEASURED AT NO SIGNAL INPUT CONDITION.
CIRCUIT AND PARTS ARE SUBJECT TO CHANGE WITHOUT PRIOR NOTICE.

CD PLAYER SECTION

EXPLODED VIEW

PARTS LIST OF UCD-65 EXPLODED VIEW

Ref. No.	Part No.	Part Name	Remarks	Qty
1	2U- 2557	CD Unit Ass'y		1 ^S
1-1	—	CD Main Unit		(1)
1-2	—	CD Display Unit		(1)
1-3	—	CD Connect Unit		(1)
2	254 4255 704	Chemicon 3300 μ F/16 V	C-105	1
3	204 8284 035	9 P System Socket	CB301	1
4	204 0284 022	15 P System Socket	CB100	1
5	411 9115 015	Main Chassis		1
6	124 0079 007	Felt Sheet		4
7	449 0088 104	Mech. Holder		3
8	412 2741 036	P.W.B. Holder(H=10)		1
9	105 1082 018	Rear Panel		1
10	337 0017 018	CD Mech. Unit		1
11	204 2307 031	7 P PH-PH Conn. Cord		1
12	204 2306 058	8 P PH-PH Conn. Cord		1
13	146 1448 200	Front Panel		1
14	—	—		1
15	143 0789 000	Lens(C)		1
16	113 1586 104	Play Button		1
17	146 1460 204	Loader Panel		1
18	102 0537 015	Top Cover		1
19	513 2121 001	Rating Sheet		1
20	412 2814 028	Card Spacer(L=10)		1
21	254 4254 792	Chemicon 2200 μ F/16 V	C-104	1
22	513 2066 001	Laser Caution		1
23	513 0985 003	Inst. Label		1
24	144 2310 001	CD Plate		1
25				
26				
SCREWS				
51	473 7002 021	Tapping Screw (S) 3 \times 8	Black	4
52	473 7015 018	Tapping Screw (S) 3 \times 8	Black	9
53	473 7500 044	Tapping Screw (P) 3 \times 8	Black	6
54	473 7505 007	Tapping Screw (P) 2.6 \times 8	Black	7
55	473 7002 034	Tapping Screw (S) 3 \times 6	Black	3
56				
PACKING & ACCESSORIES (Not included EXPLODED VIEW)				
101	505 0241 005	Cabinet Cover		1
102	503 1091 009	Cushion		1
103				
104				

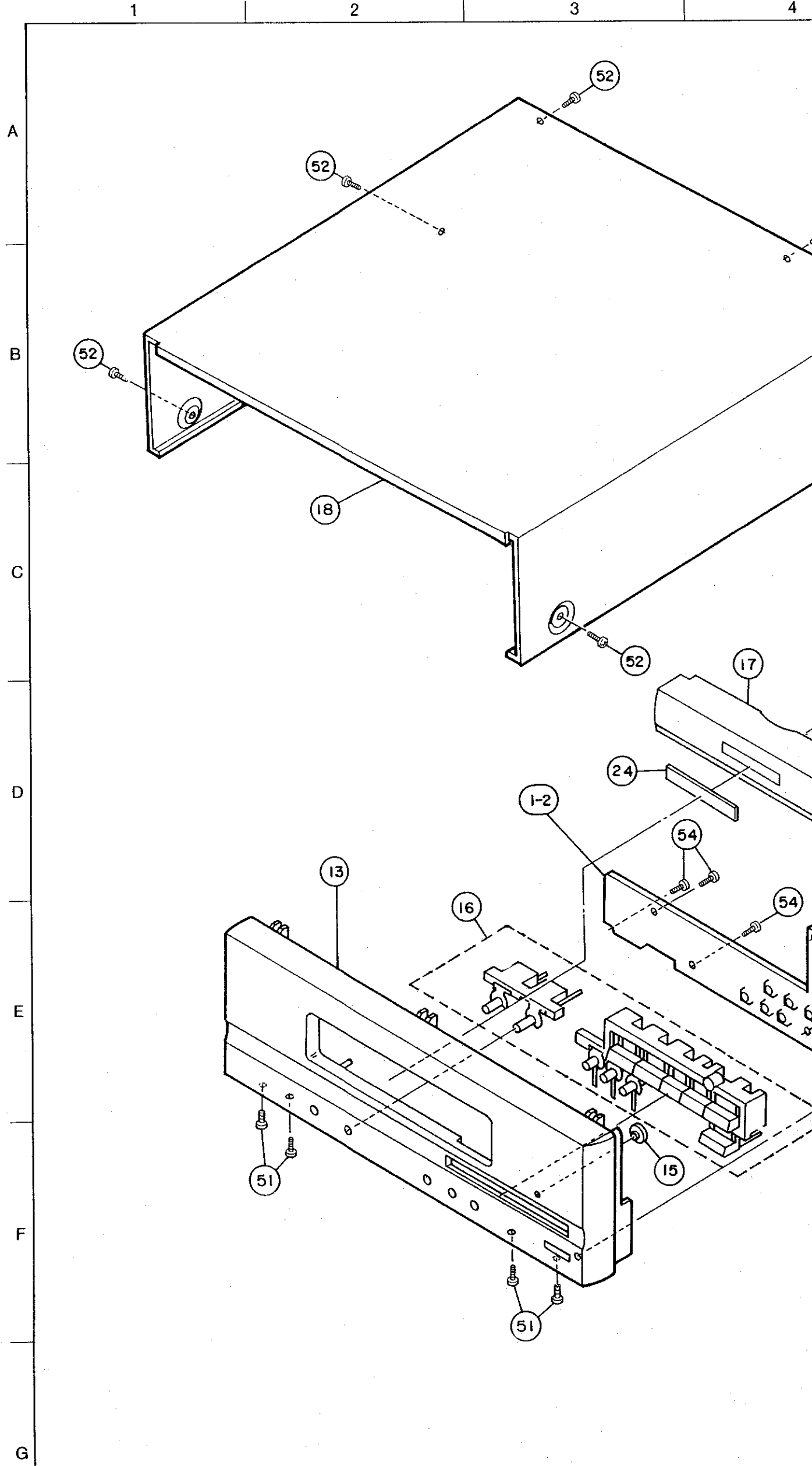

NOTE ON PARTS LIST

- Part indicated with the mark "●" are not always in stock and possibly to take a long period of time for supplying, or in some supplying of part may be refused.
- When ordering of part, clearly indicate "1" and "1" (i) to avoid mis-supplying.
- Ordering part without stating its part number can not be supplied.
- Part indicated with the mark "★" is not illustrated in the exploded view.

WARNING:

Parts marked with this symbol Δ have critical characteristics. Use ONLY replacement parts recommended by the manufacturer.

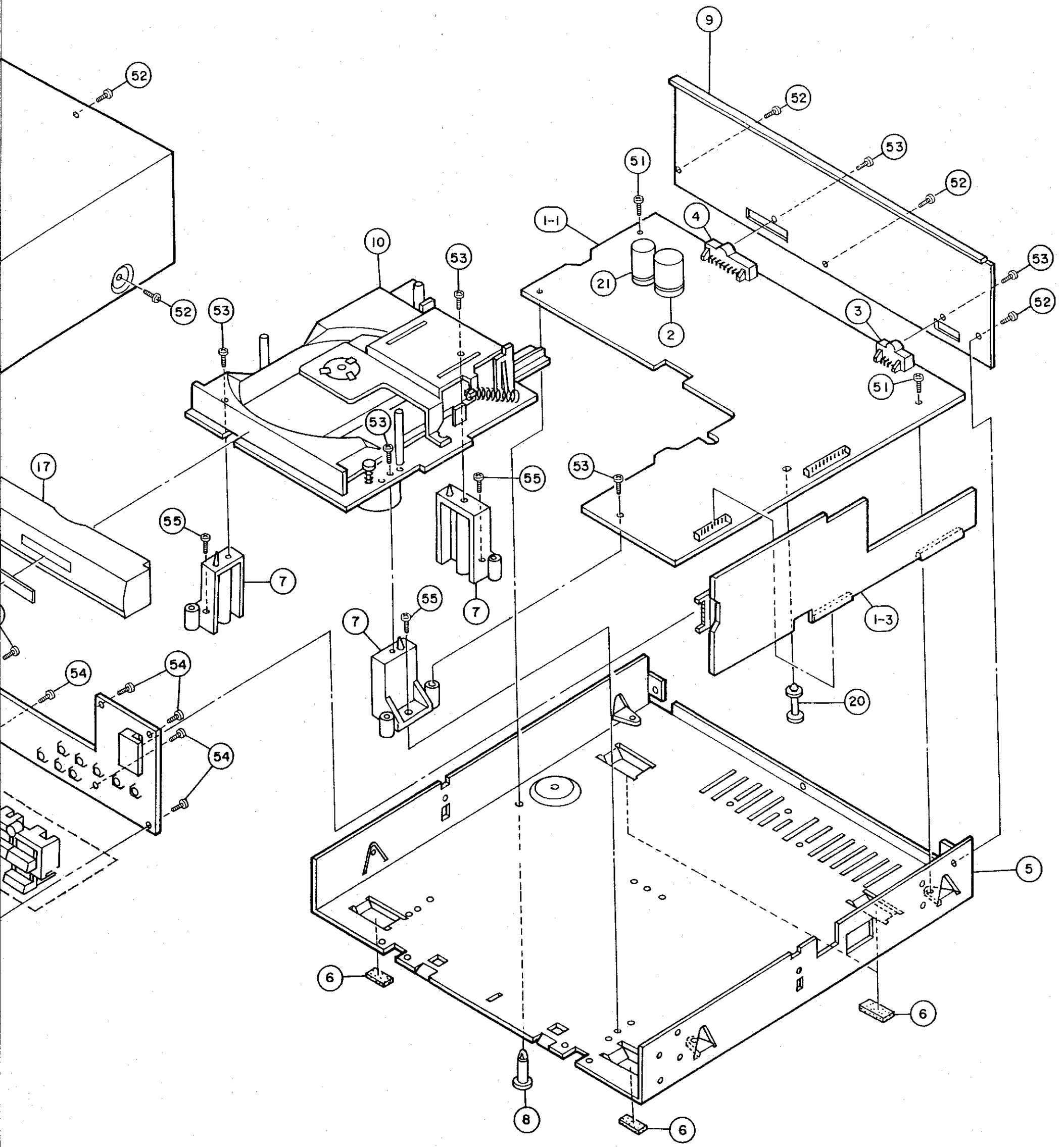

supplying, or in some case

DISASSEMBLY OF CD MECHANISM

CD PLAYER SECTION

CD MECHANISM PARTS LIST (Part No.:337 0017 018)

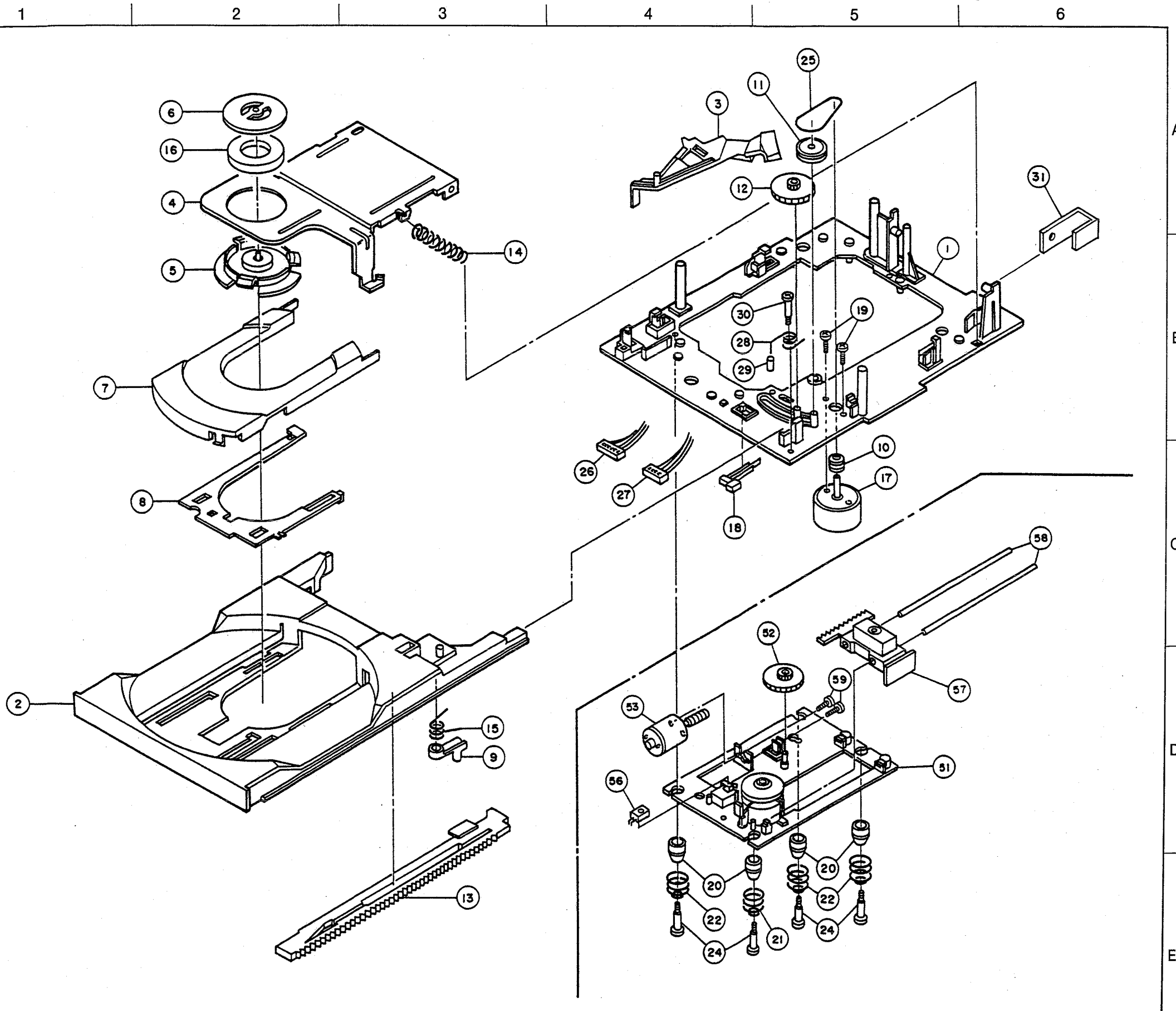

Ref. No.	Part No.	Part Name	Remarks	Qty
1	9KA 81A2 95	Loading Plate Ass'y OS		1 ^s
1-1	—	Loading Plate		(1)
2	9KA 81G9 73	Tray 201		1
3	9KA 81G9 74	Switch Lever		1
4	9KA 81P4 62	Clamper Arm		1
5	9KA 81G9 75	Clamper		1
6	9KA 81P4 63	Clamper Plate		1
7	9KA 81G9 76	Disc Holder		1
8	9KA 81G9 77	Lifter Cam		1
9	9KA 81G9 78	Latch		1
10	9KA 81G2 35	Motor Pulley	Mold	1
11	9KA 81G1 22	Pulley Gear		1
12	9KA 81G1 23	Gear 3		1
13	9KA 81G5 81	Rack 11B		1
14	9KA 81S0 59	Clamp Spring		1
15	9KA 81S0 60	Latch Spring		1
16	9KA 82G0 57	Clamper Magnet		1
17	9KM01T0 94	Motor	MDN-4RA3EZAS	1
18	9KS 01W0 51	Leaf Switch (Loading Limit Switch)	LSC122338	1
19	9KM20S0 04	Tams Screw	M2X4	2
20	9KA 82G0 56	Float Cushion M3		4
21	9KA 81S0 66	Float Spring M3 A		1
22	9KA 81S0 67	Float Spring M3 B		3
23	—	—		—
24	9KA 81H0 85	Fixing Screw C		4
25	9KA 82G2 42	Belt 1.6X18.7		1
26	9KA 82G1 23	Connector Cord	CNW 6P M3	1
27	9KA 82G1 24	Connector Cord	CNW 5P M3	1
28	9KA 81S0 71	Tray Spring 201		1
29	9KA 82G1 84	UL Tube 2X5.5		1
30	9KA 82H0 35	Floater Screw RM		1
31	463 0726 006	Support Spring		1
51	9KA 81A3 33	Spindle Motor (T/T) Ass'y	Including Motor T/Table	1 ^s
51-1	—	Unit Plate M3G2		(1)
51-2	9KA 81A2 93	Turn Table Ass'y		(1)
51-3	—	Turn Table Plate		(1)
51-4	9KM 01T1 27	Spindle Motor	MDN-4RA3EZAS	(1)
51-5	9KM 20N0 03	Pan Screw	M2X3	(2)
52	9KA 81G9 66	Slide Gear T		1
53	9KA 81A2 90	Feed Motor Ass'y		1 ^s
53-1	—	F. Motor	RD-050Y	(1)
53-2	—	Warm Gear		(1)
54	—	—		—
55	—	—		—
56	9KS 01W0 56	Switch	SPPB-11	1
57	9KA 82G3 12	Optical Pickup Ass'y	HOP-M3D	1 ^s
58	9KA 81H1 07	Guide Bar		2
59	9KM 20N0 03	Pan Screw	M2X3	2

CASSETTE DECK SECTION

DISASSEMBLY PROCEDURES

(Follow these procedures in reverse order to reassemble.)

Removing the Top Cover and the Front Panel

-) Remove the six screws that fasten the top cover.
-) The top cover is held in the rib of the front panel. Caution is required when taking off the top cover since if it is not removed in the direction of the arrow (vertically), the rib might be bent.

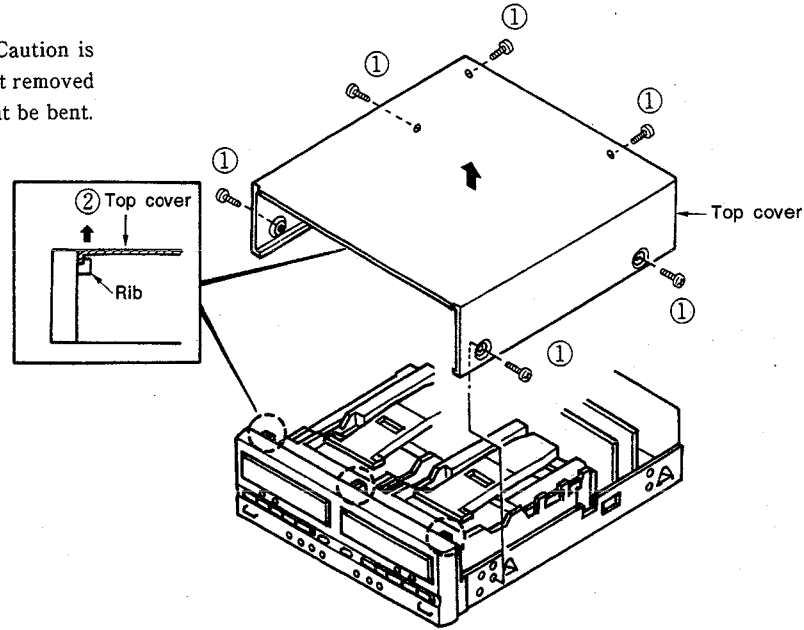

- ③ Use your finger to push out the loader frame assembly of the play only mechanism and the REC/PB mechanism in the direction of the arrow.

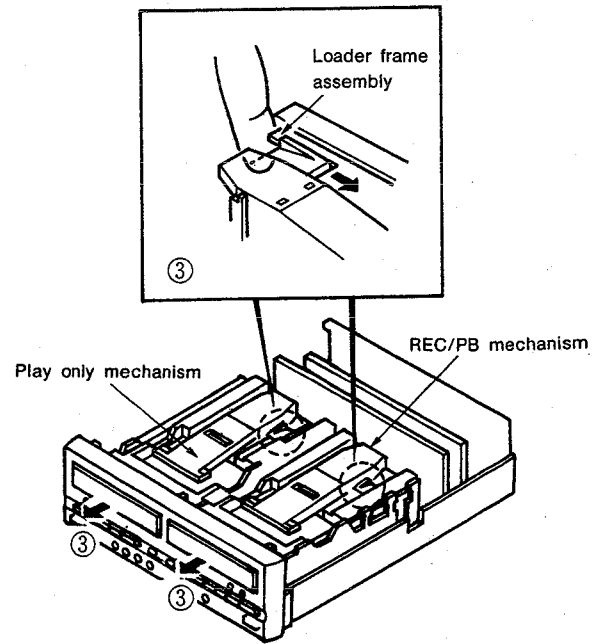

- ④ Release the hooks of the loader panel from the loader frame assembly in the direction of the arrow.
- ⑤ Close the loader frame assembly in the direction of the arrow.
- ⑥ Disconnect the CN141 FFC cable which is attached to the main unit.

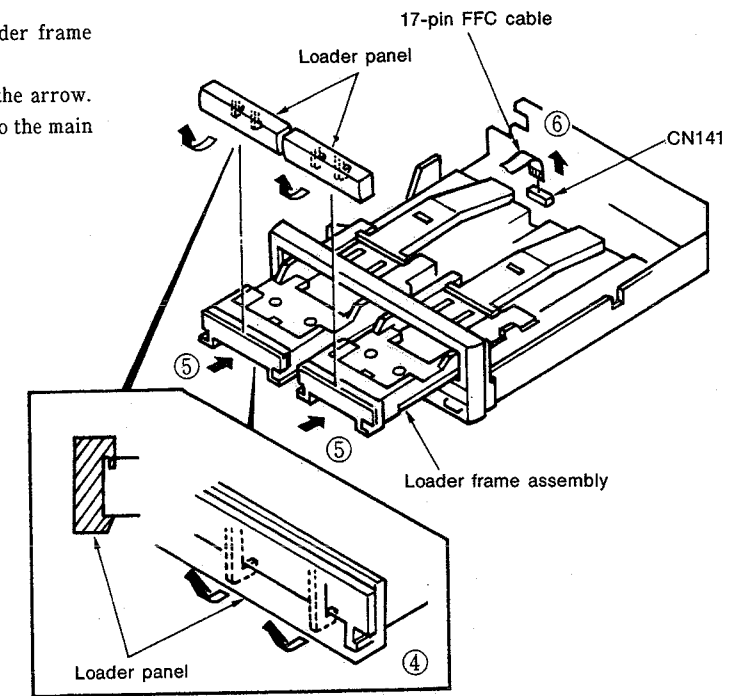

- ⑦ Remove the four screws which fasten the front panel.
- ⑧ While releasing the hooks of the front panel from the chassis, remove the front panel in the direction of the arrow.

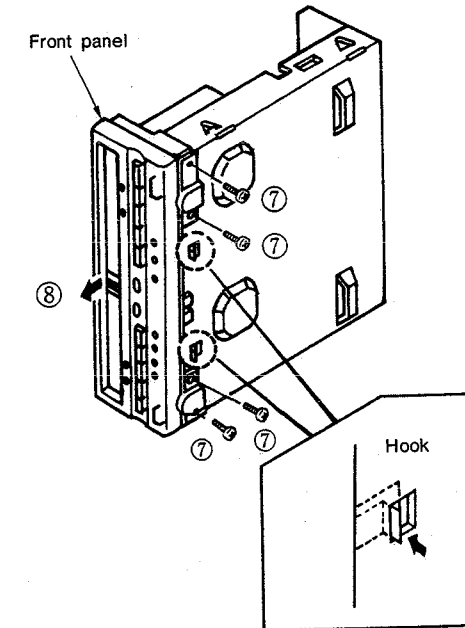

2. Removing the Various Units

LED/Switch Units (2U-2556-2)

- ① Remove the eight screws which fasten the LED/switch units.

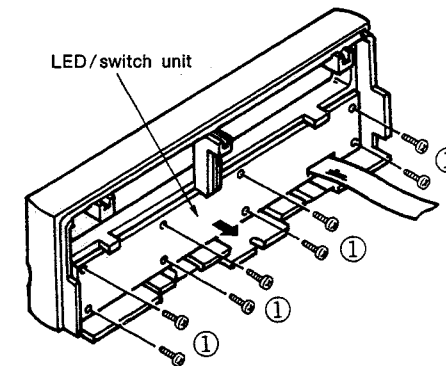

CASSETTE DECK SECTION

3. Removing the Cassette Mechanism

- ② Remove the ten screws which fasten the cassette mechanism.
- ③ Disconnect the connectors which are connected from the various boards.

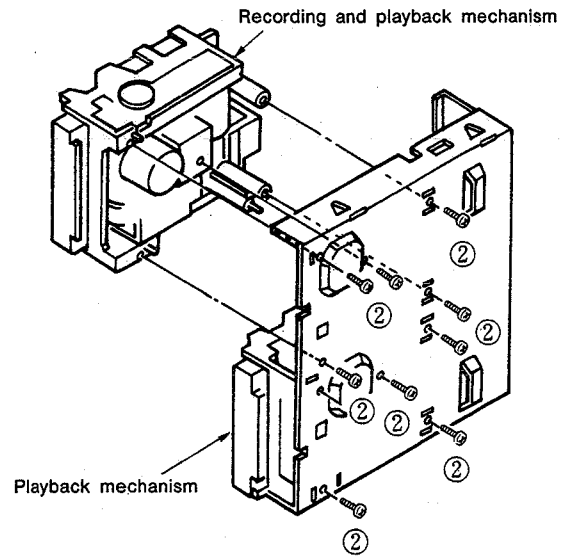

Recording/Playback Equalizer Unit (2U-2556-4), Dolby Unit (2U-2556-3)

- ④ Remove the screw which fastens the P.W.B. bracket.
- ⑤ Pull off the recording/playback equalizer unit from the connector in the direction of the arrow.
- ⑥ Pull off the Dolby unit from the connector in the direction of the arrow.

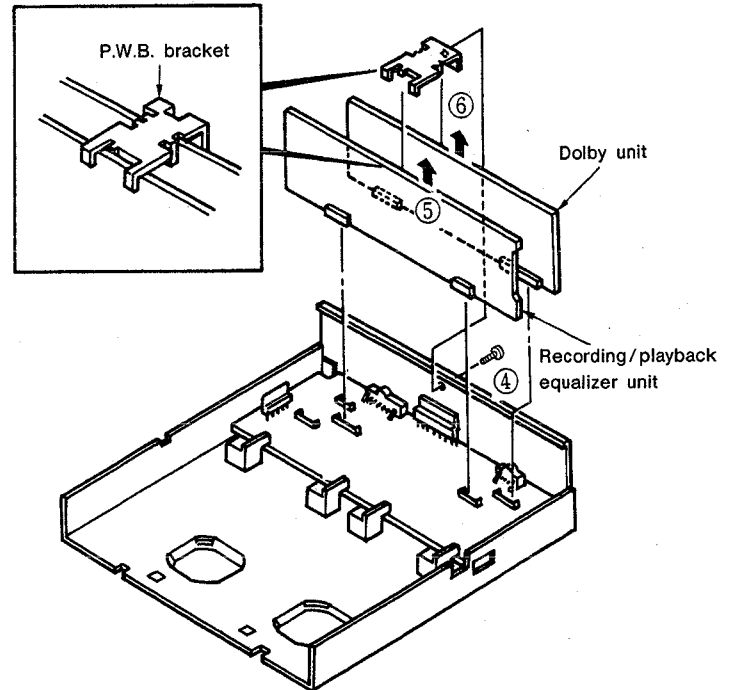

Main Unit (2U-2556-1)

- ⑦ Remove the seven screws which fasten the rear panel.
- ⑧ Remove the two screws which fasten the main unit and remove the main unit in the direction of the arrow.

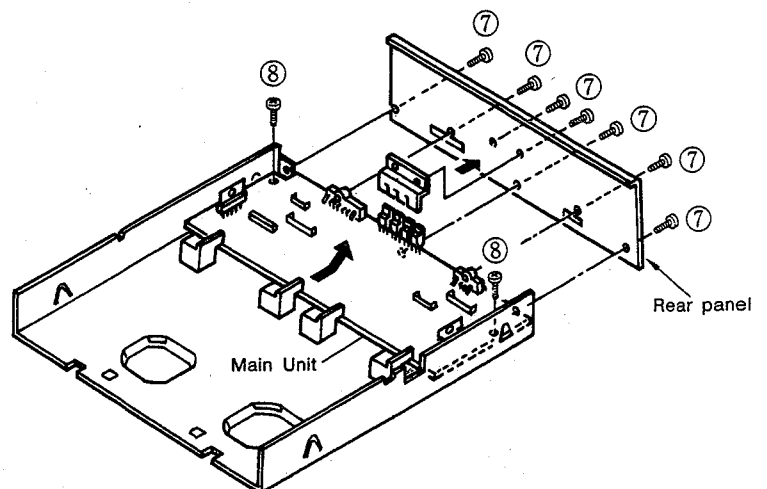

CASSETTE DECK SECTION

LEVEL DIAGRAM

(Recording)

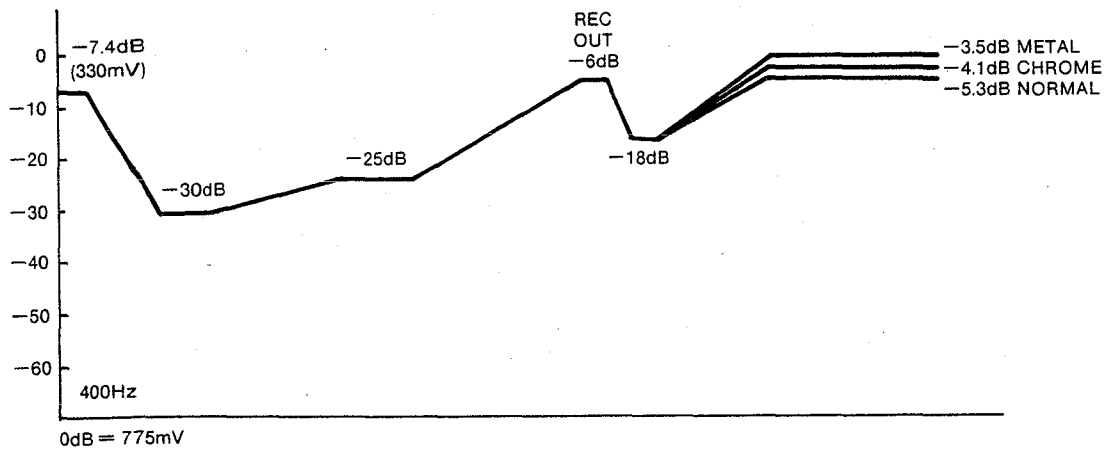
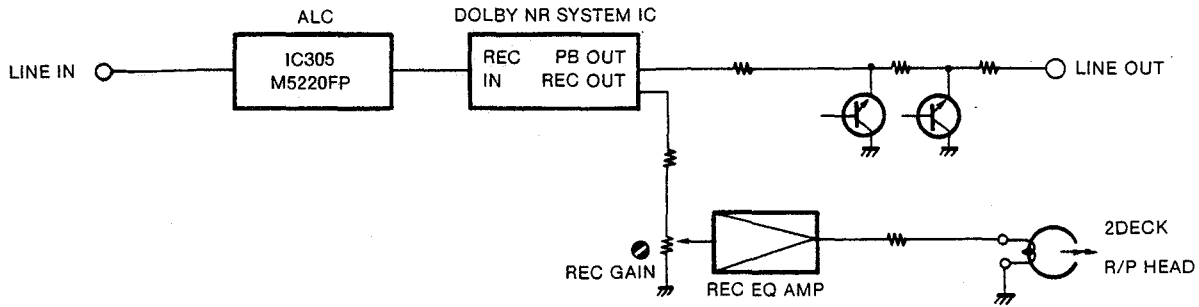

(Playback)

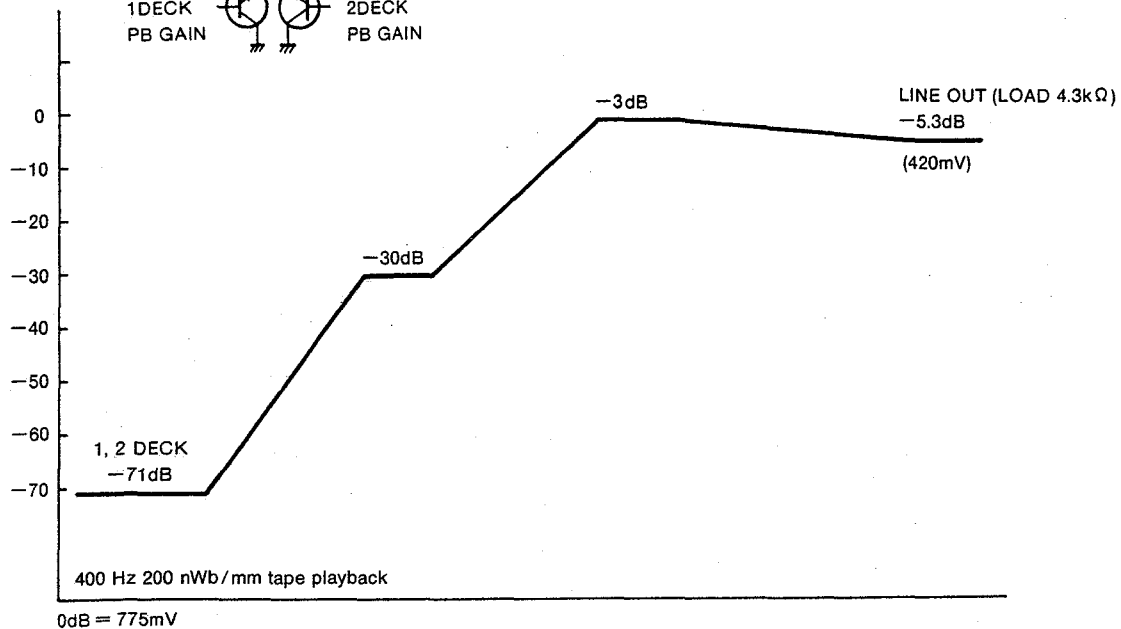
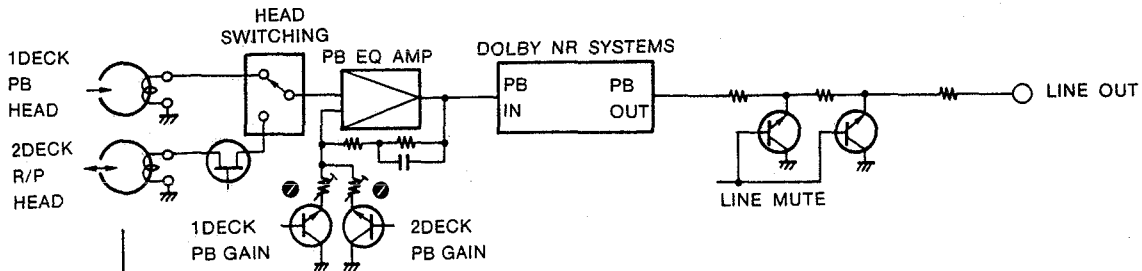

CASSETTE DECK SECTION

BLOCK DIAGRAM

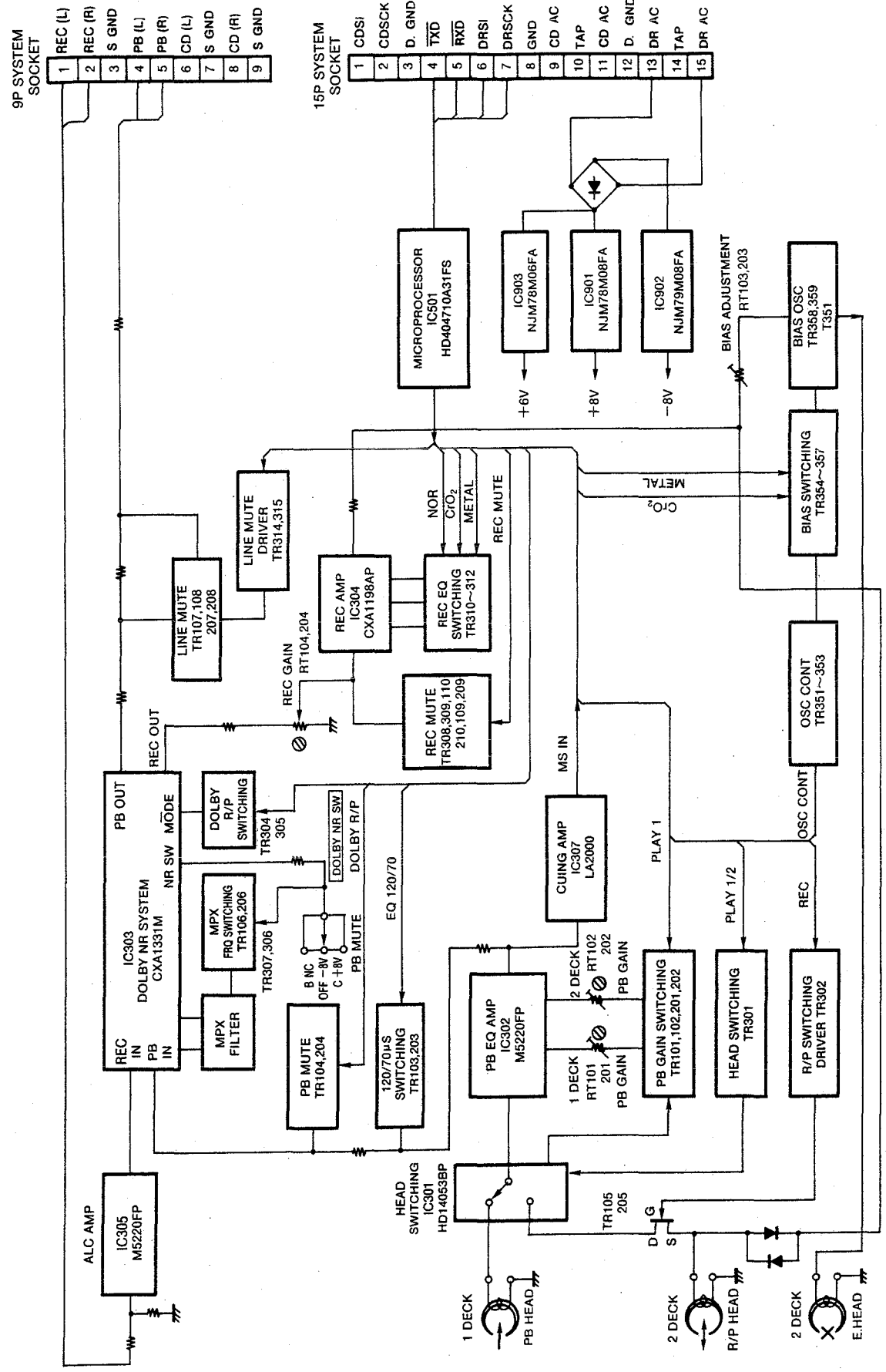

CASSETTE DECK SECTION

ADJUSTMENT

● Mechanism Measurements

Measurement item	Standard value	Remarks
Winding torque (PLAY)	35~70 gcm	SONY TW-2111 for forward, TW-2121 for reverse
Fast-forward and rewind torque	70~180 gcm	SONY TW-2231
Back tension torque	$2 \pm_{-1.3}^{2.3}$ gcm	SONY TW-2111 for forward, TW-2121 for reverse
Pinch roller pressure	270 ± 50 g	See diagram at right
Fast-forward and rewind time	110 ± 15 s	C-60

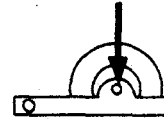

With the deck in the play mode, apply force with the tension gauge in the direction of the arrow and read the value at which the pinch roller stops rotating.

● ELECTRICAL ADJUSTMENTS

● Preparations Before Adjustments

1. Measuring Instruments Necessary for Adjustments

- Screwdriver: Small flat-bladed screwdriver for variable resistors
- Low frequency oscillator
- Attenuator
- V.T.V.M.
- Oscilloscope
- Frequency counter
- Test tapes (TEAC MTT-111, MTT-114, MTT-150, DENON HDX/60, or equivalent)
(A-BEX TCC-111, TCC-153, TCC-130)
- Load resistor 47kohm 2pcs. (A-BEX, TC-111, TCC-153, TCC-130)

● Adjustment notes

- ① Before adjusting, wipe the surface of the heads, the capstans, and the pinch rollers with a piece of gauze moistened with alcohol.
- ② Demagnetize the playback, recording, and erasure heads with a head eraser.
- ③ Completely demagnetize the adjustment screwdriver.
- ④ Unless otherwise specified, set the switches at the following positions and use the P.B Terminal for the input, and TP102 of the 2U-2556B-3 (Dolby unit) for the output.
DOBLY NR SW: OFF
- ⑤ Use an alligator clip cord to short circuit TP-101 of the 2U-2556-3 Dolby unit as shown in the diagram to the right and on Page 83.



2. Playback adjustments

2-1 Azimuth adjustment

Play back the (TEAC MTT-114) test tape and turn the azimuth adjustment scrw to yield maximum values for the left and right channels.
Lock the screw.

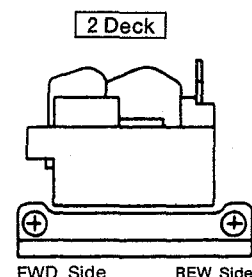
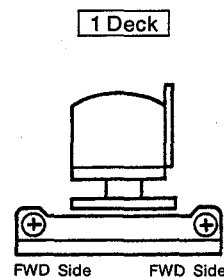
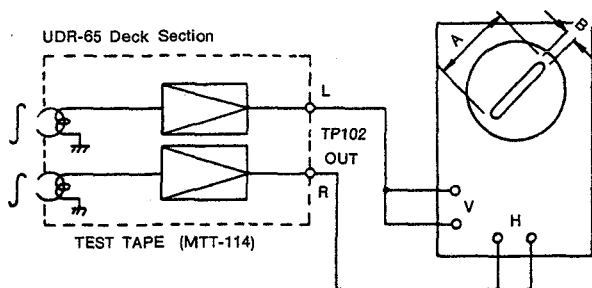

CASSETTE DECK SECTION

2-2 Tape speed check and adjustment

- Connect the frequency counter to TP-102.
- ① Play the test tape (MTT-111) on deck 1 and once tape transport has stabilized, adjust normal-speed-adjustment variable resistor (motor Variable Resistor) to yield 3,000 Hz \pm 10 Hz.
- ② Using the same procedure on deck 2, adjust variable resistor (motor Variable Resistor).

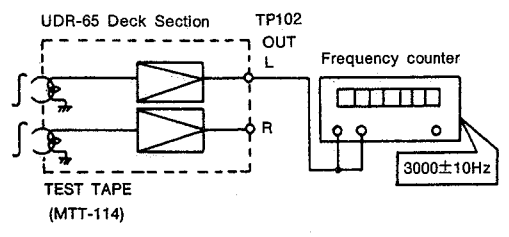

NOTE: Use the central portion of the test tape; not the beginning or end of the winding.

2-3 Playback level check and adjustment

Play a Dolby reference level tape (TEAC MTT-150) and check that the voltage of the left and right monitor outputs of TP-102 on the 2U-2556-3 Dolby unit is within 548 mV \pm 1 dB.

If it is not within this range, the playback level requires adjustment.

NOTE: When adjusting deck 1, the playback level of deck 2 also changes; therefore, the playback level of deck 2 should be readjusted.

- For deck 1, adjust: RT101 (Left channel), and RT201 (right channel)
- For deck 2, adjust: RT102 (Left channel), and RT202 (right channel)

Caution: Always adjust the playback level starting from the left deck first.

3. Recording adjustments (deck 2 only)

3-1 Overall frequency response adjustment for recording and playback

Load a blank DENON HDX/60 tape for adjustment purposes and record and play it back, adjusting the input attenuators of the 1 kHz and 10 kHz signals to yield a left and right monitor output voltage of 54.8 mV at TP102 of the 2U-2556B-3 deck unit. Adjust so that the 10 kHz level is about +0.5 dB with respect to 1 kHz, and the overall response is within the range shown in the diagram below.

- If the 10 kHz output is larger than the 1 kHz output, turn RT103 (left channel) and RT203 (right channel) counterclockwise, and if it is smaller, turn these controls clockwise.

3-2 Recording level check and adjustment

Load a blank DENON HDX/60 tape for adjustment purposes and check that the voltmeter indication is within the 54.8 mV \pm 1 dB range when a 1 kHz signal is recorded and played back.

If it is not within this range, the recording level requires adjustment.

- If the level at the time of playing back the recording is higher than at the time of recording, turn RT104 (left channel) and RT204 (right channel) counterclockwise, and if lower, turn these controls clockwise.

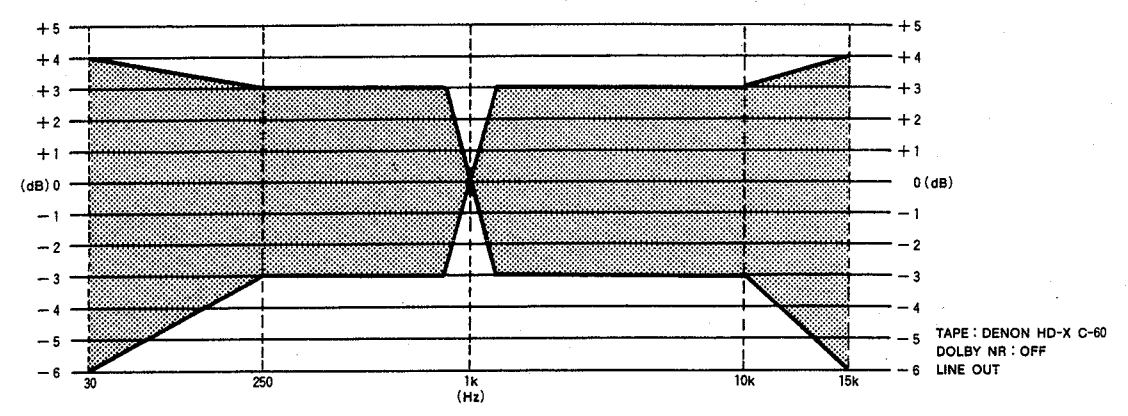

OUTLINE DIAGRAM OF ADJUSTMENT LOCATION

2U-2556-3 DOLBY UNIT (Component Side)

2U-2556-4 REC/PB EQ. UNIT (Component Side)

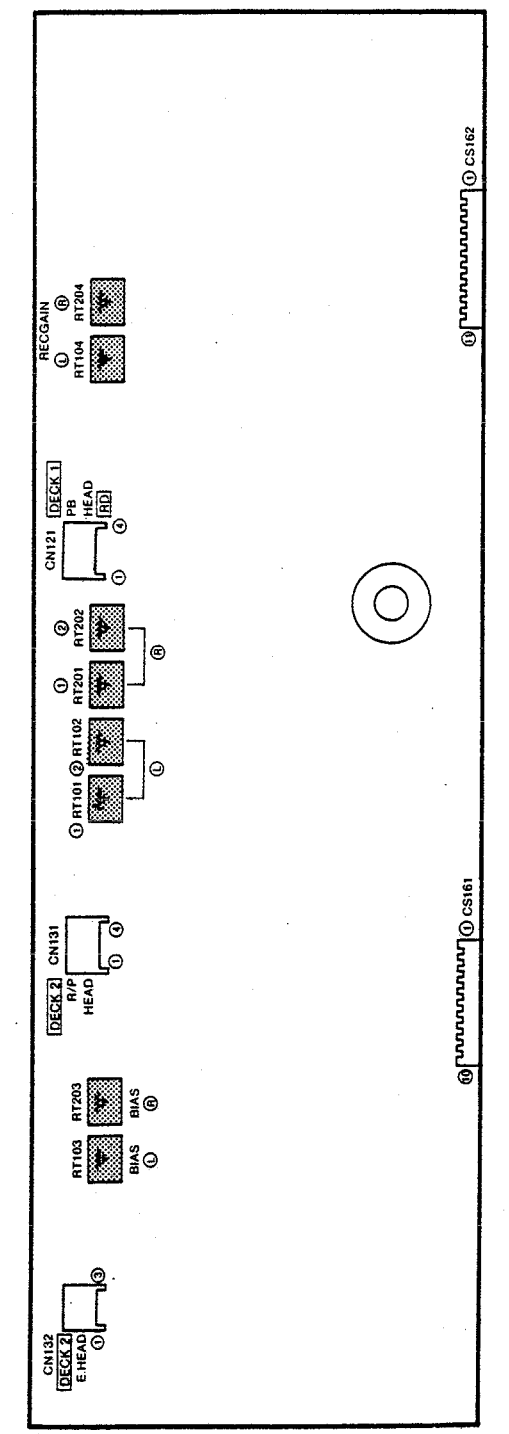
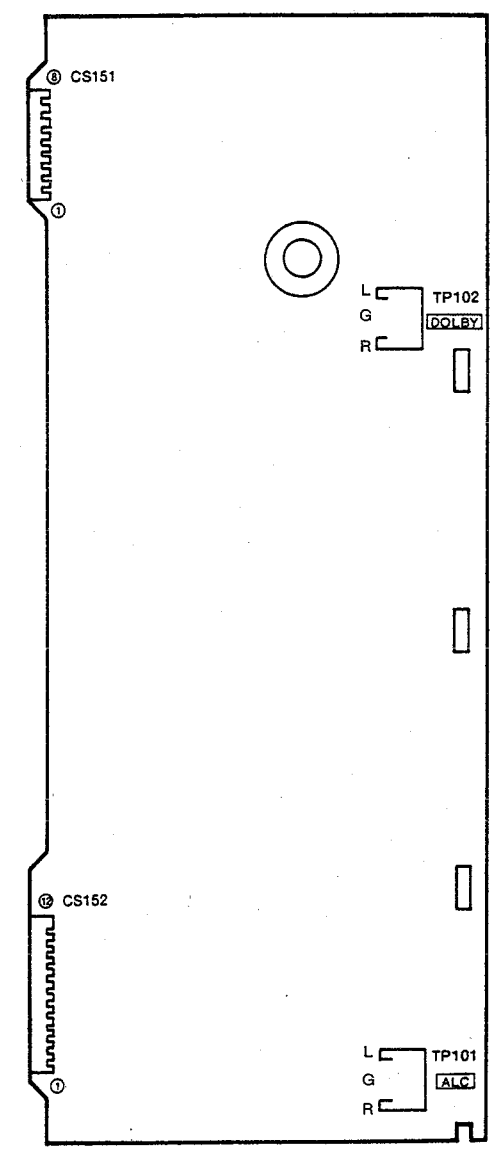

CASSETTE DECK SECTION

SEMICONDUCTORS

IC's

D14053BFP (IC301)

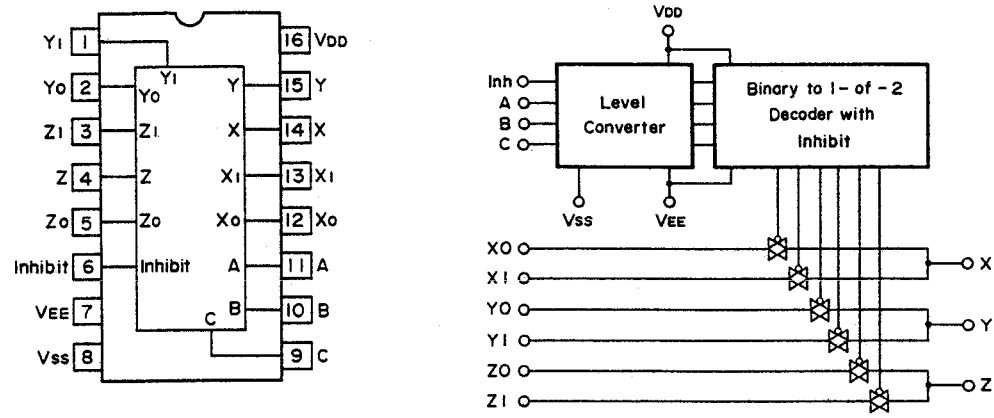
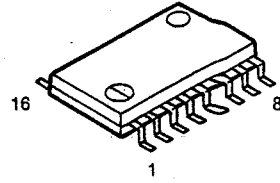

CXA1331M (IC303)

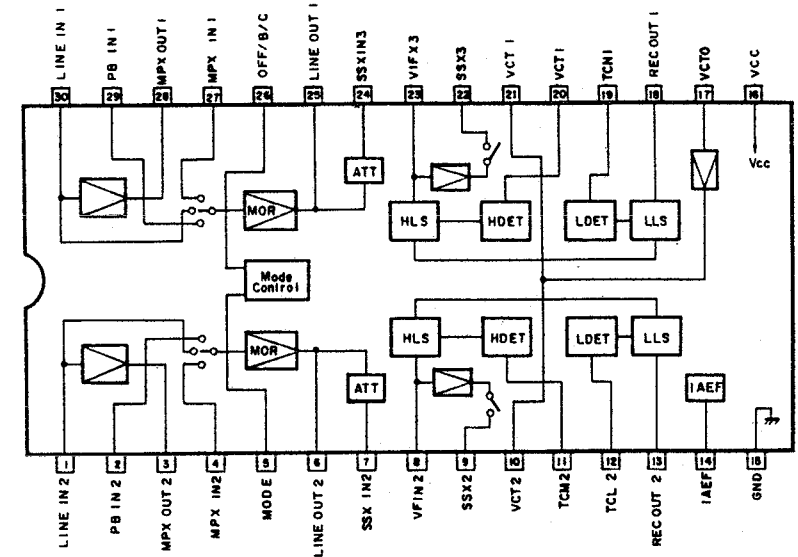
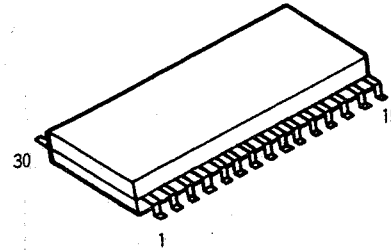

CXA1198AP (IC304)

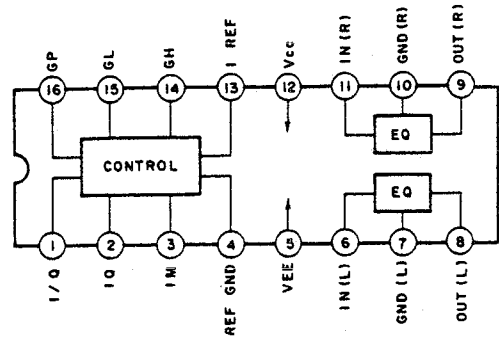
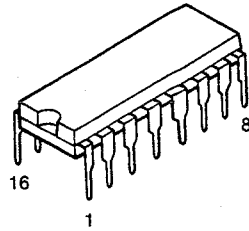

LA2000 (IC307)

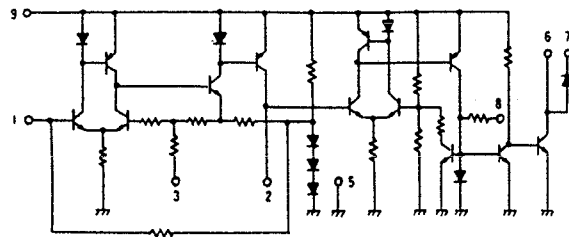
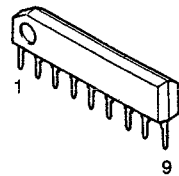

NJM78M06FA (S) (IC903)
NJM78M08FA (S) (IC901)
(Three-pin positive voltage supply)

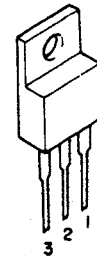

1 : Output
2 : GND
3 : Input

NJM79M08FA (IC902)
(Three-pin negative voltage supply)

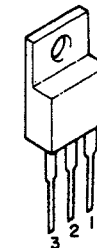

1 : Output
2 : Input
3 : GND

M5220FP (IC302, 305)

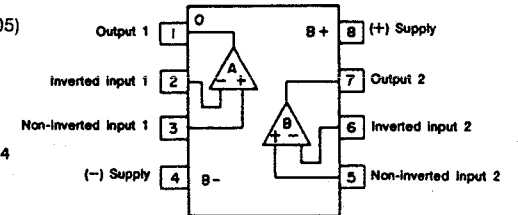
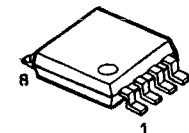

BA6209 (IC601, 651)
Reversible motor driver

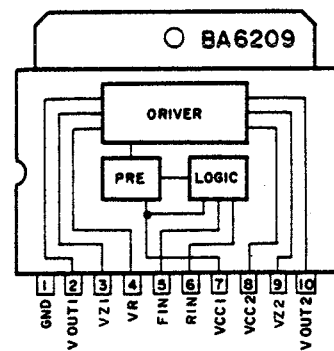
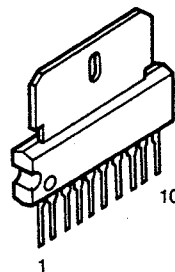

BA15218F (IC306)

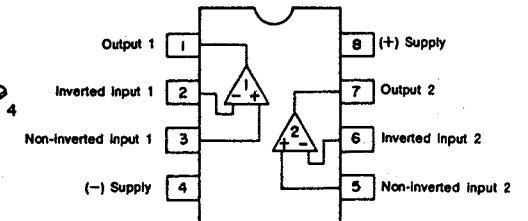
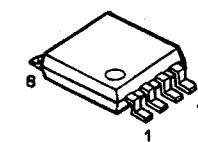

CASSETTE DECK SECTION

● Transistors

2SA933S (S)

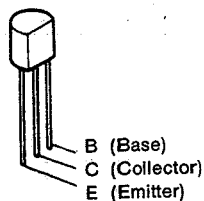

2SB562 (C)

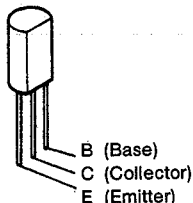

2SC1740S (S)

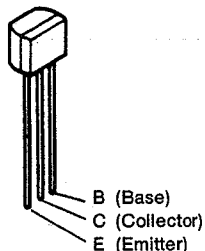

2SC3852

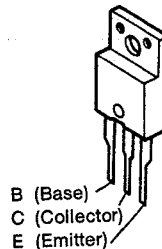

2SK373 (Y) (FET)

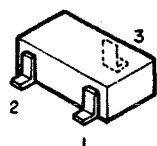
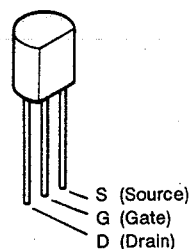

- 1 : Emitter
- 2 : Base
- 3 : Collector

DTA EK Series

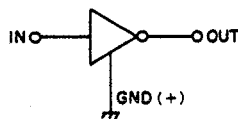
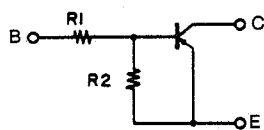

	R1	R2
DTA114EK	10k ohm	10k ohm
DTA144EK	47k ohm	47k ohm

DTC TK Series

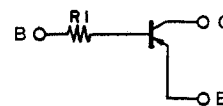

	R1
DTC323TK	2.2k ohm

DTC EK Series

- DTA114EK } PNP Type
- DTA143EK }
- DTC114EK } NPN Type
- DTC124EK }
- DTC144EK }
- DTC323TK }

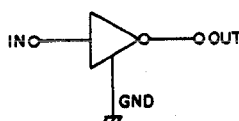
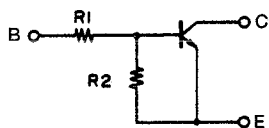

	R1	R2
DTC114EK	10k ohm	10k ohm
DTC124EK	22k ohm	22k ohm
DTC144EK	47k ohm	47k ohm

2SA1037K (S/R)
2SC2412K (S)
2SC3326 (A/B)

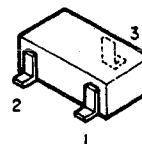

- 1 : Emitter
- 2 : Base
- 3 : Collector

RN1444

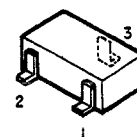

- 1 : Emitter
- 2 : Base
- 3 : Collector

● Diodes

- HZS4B-1
- HZS6A-1
- HZS6C-1
- HZS7C-1
- HZS9B-1
- HZS12A-1



1SS254



1SR35-200A



● LED ASS'Y

SLR-34MC70F (Green)
SLR-34VC70F (Red)

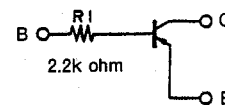
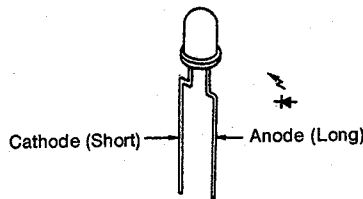

CASSETTE DECK SECTION

MICROPROCESSOR DOCUMENTATION

- Control Circuits for the Deck
 HD404710A31FS : 262 1820 201 (IC501)
 (CMOS 4-bit single-clip microprocessor)

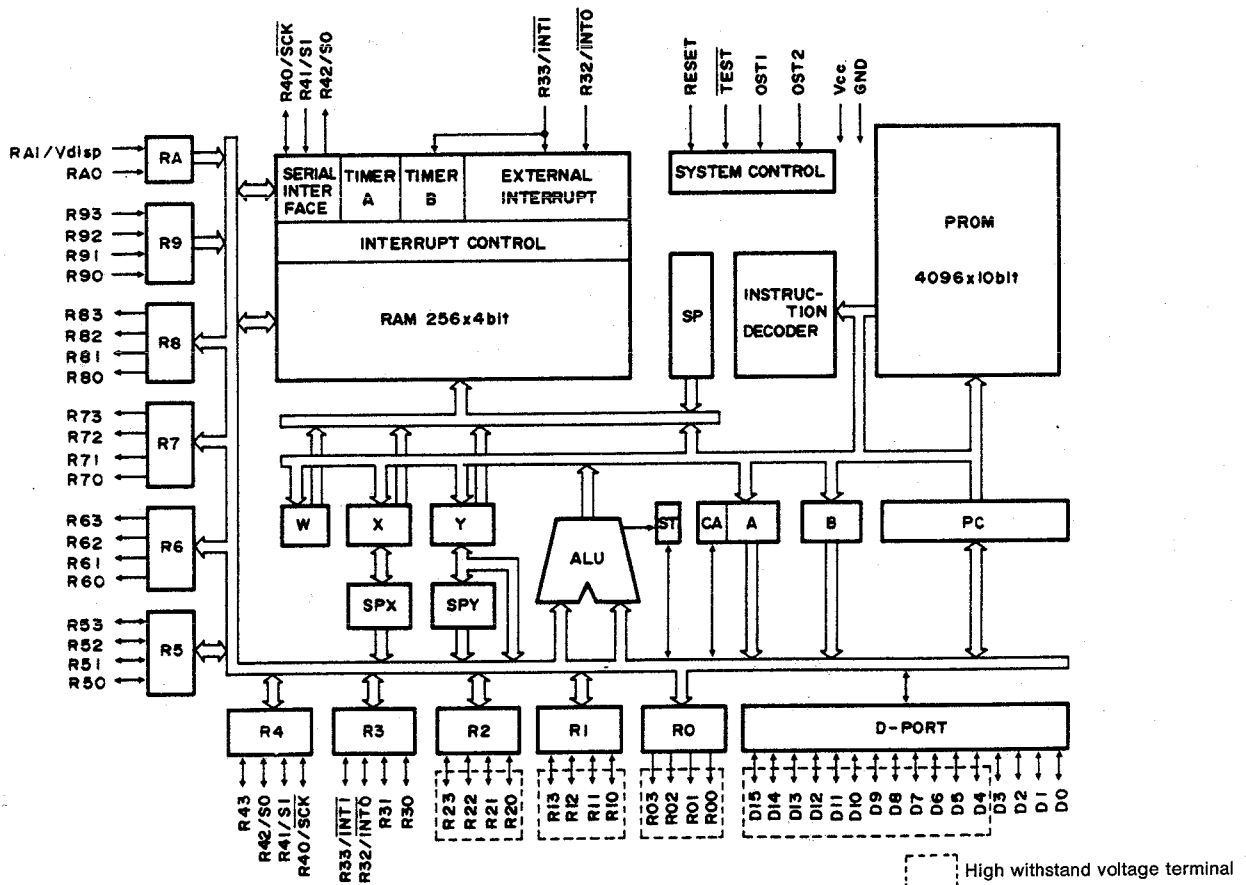
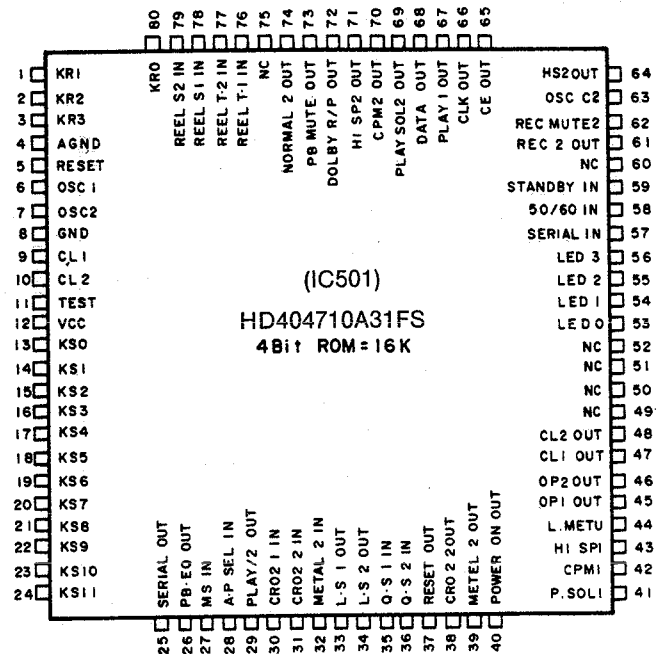

CASSETTE DECK SECTION

● IC Pin Description

No.	Port Name	Function Name	Function
1	RD1/AN5	KR1	Key return 1 input pin
2	RD2/AN6	KR2	Key return 2 input pin
3	RD3/AN7	KR3	Key return 3 input pin
4	A GND		Ground (In)
5	RESET	RESET	Reset input pin
6	OSC1		4 MHz ceramic lock
7	OSC2		4 MHz ceramic lock
8	GND		Ground
9	CL1	NC	Ground (In)
10	CL2	NC	Open
11	TEST	NC	5 V
12	VCC		5 V
13	D0	KS0	Key strobe 0 output pin
14	D1	KS1	Key strobe 1 output pin
15	D2	KS2	Key strobe 2 output pin
16	D3	KS3	Key strobe 3 output pin
17	D4	KS4	Key strobe 4 output pin
18	D5	KS5	Key strobe 5 output pin
19	D6	KS6	Key strobe 6 output pin
20	D7	KS7	Key strobe 7 output pin
21	D8	KS8	Key strobe 8 output pin
22	D9	KS9	Key strobe 9 output pin
23	D10	KS10	Key strobe 10 output pin
24	D11	KS11	Key strobe 11 output pin
25	D12	SERIAL SIG OUT	Output pin for serial communications. (Active low)
26	D13	PB EQ OUT	Playback equalizer switching output pin. "L" for 120 μ s; "H" for 70 μ s.
27	D14	MS IN	Inter track detection signal input pin from the IC used for inter track detection. (Active low)
28	D15	A.P. SEL IN	Auto power on/off switching Auto power on/off is performed at "H" Auto power on/off is not performed at "L"
29	R00	PLAY 1/2 OUT	This output pin displays the play condition of the mechanisms. "L" during play of mechanism 1 "H" during play of mechanism 2
30	R01	CROM 1 IN	Tape type detection switch input pin of mechanism 1 "L" for normal tape "H" for chrome or metal tape
31	R02	CROM 2 IN	Tape type detection switch input pin of mechanism 2
32	R03	METAL 2 IN	Tape type detection switch input pin of mechanism 2. Backed up.
33	R10	PLAY 1 OUT	
34	R11	T. CHECK OUT	
35	R12	FADE 1 OUT	Fade out recording control output pin.
36	R13	FADE 2 OUT	Fade out recording control output pin.
37	R20	RESET OUT	Outputs "L" for 4 seconds following the reset start up, then outputs "H" thereafter.
38	R21	CROM 2 OUT	This output pin switches the recording equalization of tape 2 to chrome. (Active high)
39	R22	METAL 2 OUT	This output pin switches the recording equalization of tape 2 to metal. (Active high)
40	R23	POWER ON/OFF OUT	This output pin controls power on/off. "H" for switching power on "L" for switching power off

CASSETTE DECK SECTION

No.	Port Name	Function Name	Function
41	R30	PLAY SOL 1 OUT	This output pin drives the solenoid of mechanism 1. (Active high)
42	R31	CPM 1 OUT	This pin outputs the pulse which drives the capstan motor of mechanism 1. (Active high)
43	R32	HI-SP 1 OUT	This output pin is used to switch to a higher speed the rotation of the capstan motor of mechanism 1 at the time of high speed copying (dubbing). (Active low)
44	R33	LINE MUTE OUT	This is the playback output mute pin. (Active high) This pin outputs "L" when tape 1 or 2 is in the play, record, record pause, record mute, or dubbing modes; "H" is output at other times.
45	R40	OPEN 1 OUT	This output pin is used to open the loader of mechanism 1. (Active high)
46	R41	OPEN 2 OUT	This output pin is used to open the loader of mechanism 2. (Active high)
47	R42	CLOSE 1 OUT	This output pin is used to close the loader of mechanism 1. (Active high)
48	R43	CLOSE 2 OUT	This output pin is used to close the loader of mechanism 2. (Active high)
49	R50/Vdisp	NC	Ground (In)
50	R51	NC	Ground (In)
51	R52	NC	Ground (In)
52	R53	NC	Ground (In)
53	R60/COMP	LED 0	Output pin for mode display drive. (Active low)
54	R61/Vref	LED 1	Output pin for mode display drive. (Active low)
55	R62/TOE1	LED 2	Output pin for mode display drive. (Active low)
56	R63/TOE2	LED 3	Output pin for mode display drive. (Active low)
57	R70/INT0	SERIAL SIG IN	Input pin for serial communications. (Active low)
58	R71/INT1	50/60 IN	50/60 Hz pulse input pin
59	R72/INT2	STANDBY IN	This input pin sets the microprocessor to the standby mode.
60	R73/INT3	NC	Ground (In)
61	R80/INT4	REC 2 OUT	Tape 2 recording mode output pin. "H" at the time of the recording mode.
62	R81/INT5	REC MUTE 2 OUT	This output pin controls the muting of the recording amplifier of tape 2. (Active high)
63	R82/SO1	OSC CONT 2 OUT	This output pin controls the bias oscillation of tape 2. (Active low)
64	R83/SI1	HI-SP REC 2 OUT	This output pin is used for switching the time constant of the signal system at the time of high speed dubbing (copying).
65	R90/SCK1		(Open)
66	R91/SCK2	DR SCK OUT	Communications clock output pin for the display.
67	R92/SI2		(Open)
68	R93/SO2	DR DATA OUT	Communications data output pin for the display.
69	RA0/ICT0	PLAY SOL 2 OUT	This outputs the pulse which drives the solenoid of mechanism 2. (Active high)
70	RA1/ICT2	CPM 2 OUT	This pin outputs the pulse which drives the capstan motor of mechanism 2. (Active high)
71	RA2/TOG	HI-SP 2 OUT	This output pin is used to switch to a higher speed the rotation of the capstan motor of mechanism 2 at the time of high speed copying (dubbing).
72	RA3/BUZZ	DOLBY R/P OUT	This output pin switches the Dolby recording/playback mode.
73	RB0/TOG	PB MUTE OUT	Muting output pin of the playback equalizer.
74	RB1/TOG	NORMAL 2 OUT	This output pin switches the recording equalization of tape 2 to normal. (Active high)
75	AVCC	NC	5 V
76	RC0/AN0	REEL T1 IN	Reel pulse take-up 1 input pin.
77	RC1/AN1	REEL T2 IN	Reel pulse take-up 2 input pin.
78	RC2/AN2	REEL S1 IN	Reel pulse supply 1 input pin.
79	RC3/AN3	REEL S2 IN	Reel pulse supply 2 input pin.
80	RD0/AN4	KR0	Key return 0 input.

MICROPROCESSOR PERIPHERAL WIRING DIAGRAM

CASSETTE DECK SECTION

1 2 3 4 5 6 7 8

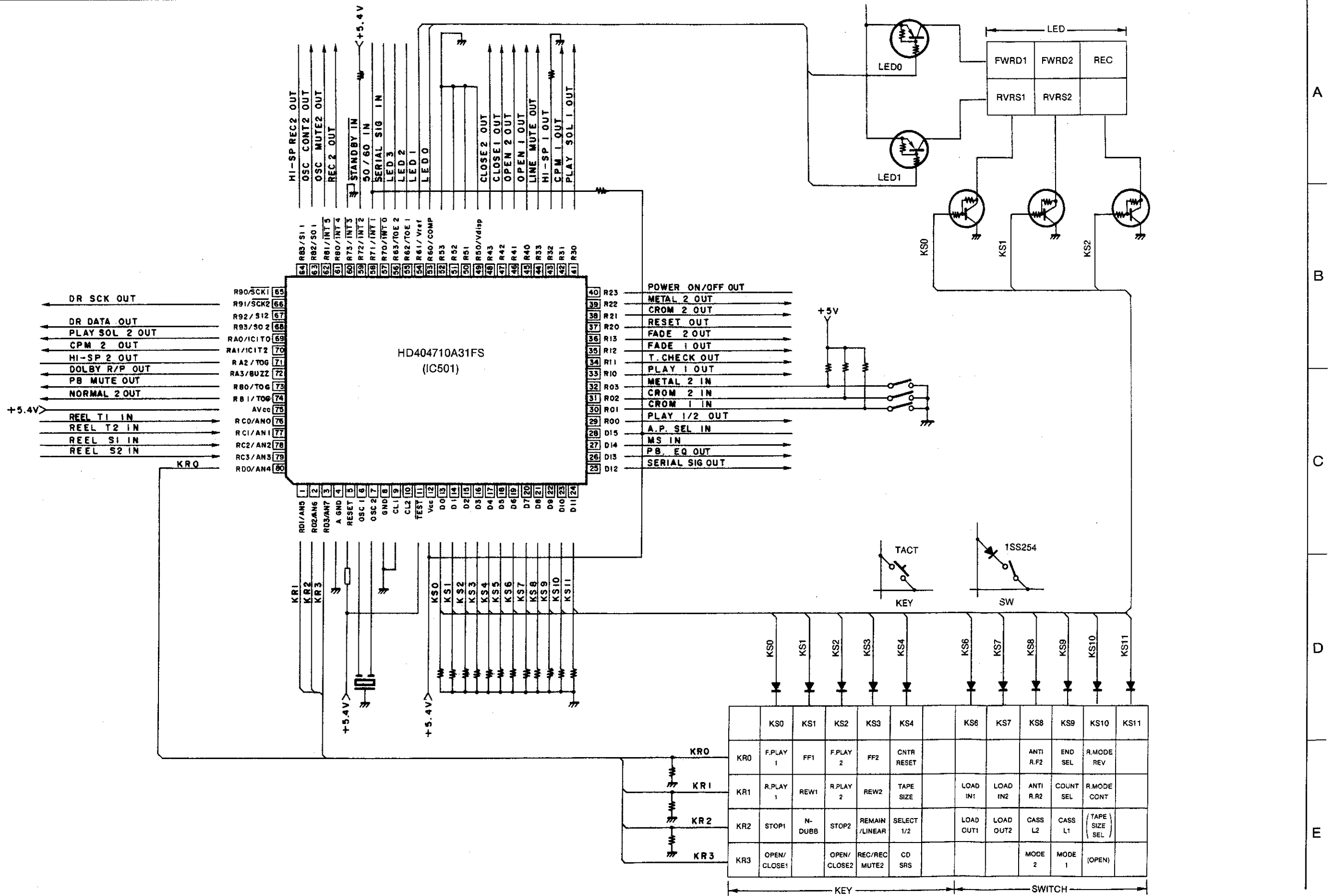

	KS0	KS1	KS2	KS3	KS4		KS6	KS7	KS8	KS9	KS10	KS11
KR0	F.PLAY 1	FF1	F.PLAY 2	FF2	CNTR RESET				ANTI R.F2	END SEL	R.MODE REV	
KR1	R.PLAY 1	REW1	R.PLAY 2	REW2	TAPE SIZE		LOAD IN1	LOAD IN2	ANTI R.R2	COUNT SEL	R.MODE CONT	
KR2	STOP1	N-DUBB	STOP2	REMAIN /LINEAR	SELECT 1/2		LOAD OUT1	LOAD OUT2	CASS L2	CASS L1	(TAPE SIZE SEL)	
KR3	OPEN/ CLOSE1		OPEN/ CLOSE2	REC/REC MUTE2	CD SRS				MODE 2	MODE 1	(OPEN)	

A
B
C
D
E

1

2

3

4

5

6

7

8

Component Side 2U-2556B DECK UNIT ASS'Y

2U-2556B	
1	Main Unit
2	LED/Switch Unit
3	Dolby Unit
4	REC/PB EQ. Unit

A

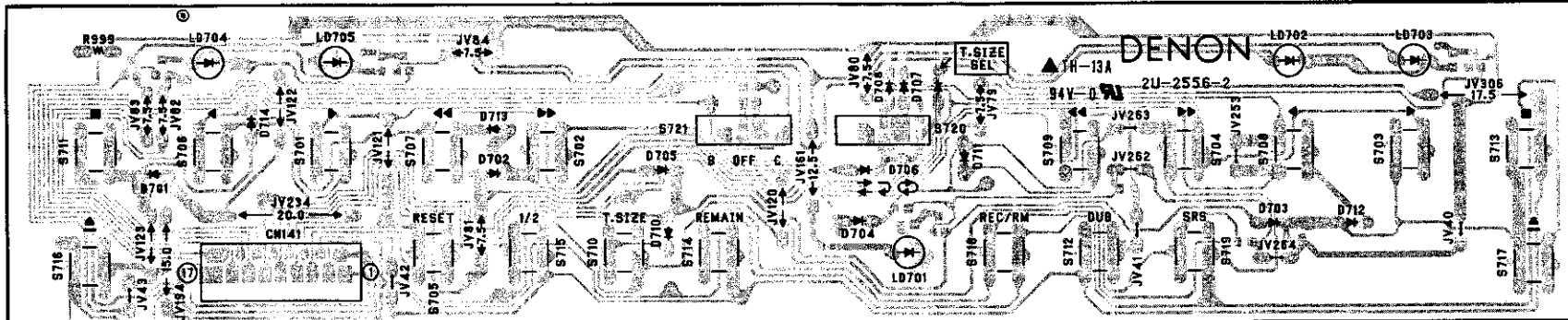

B

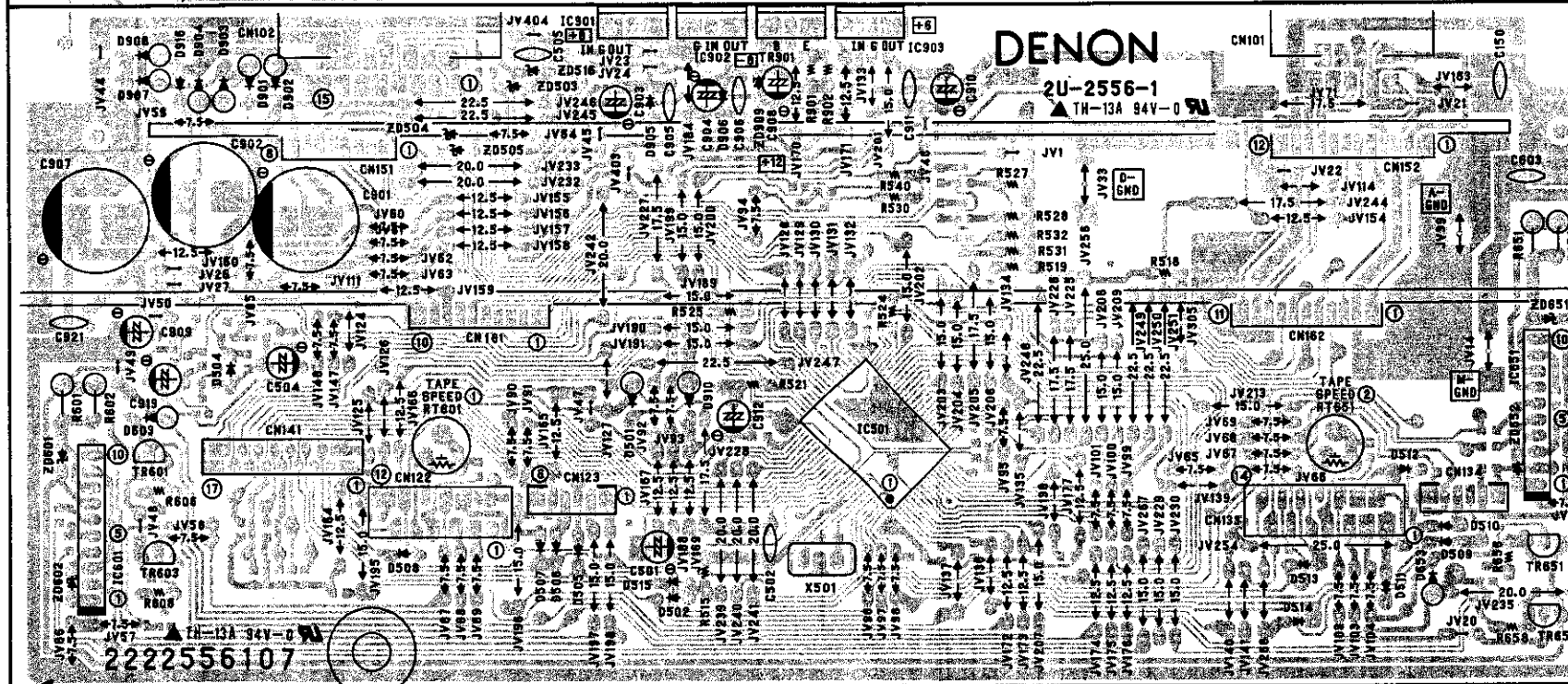

C

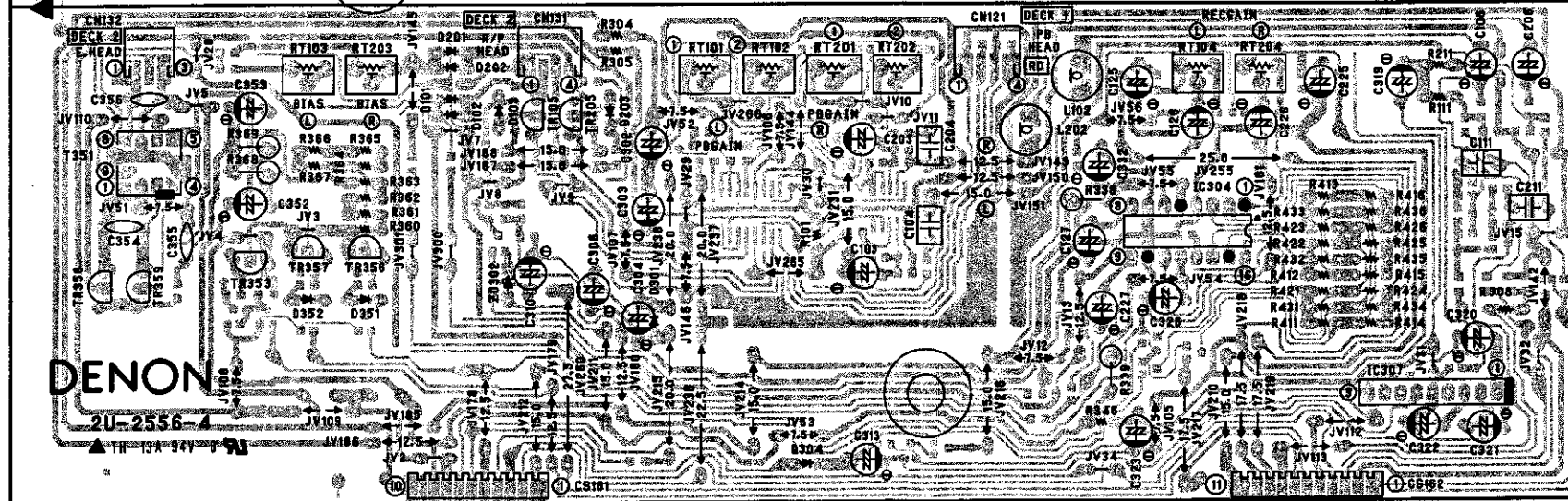

D

E

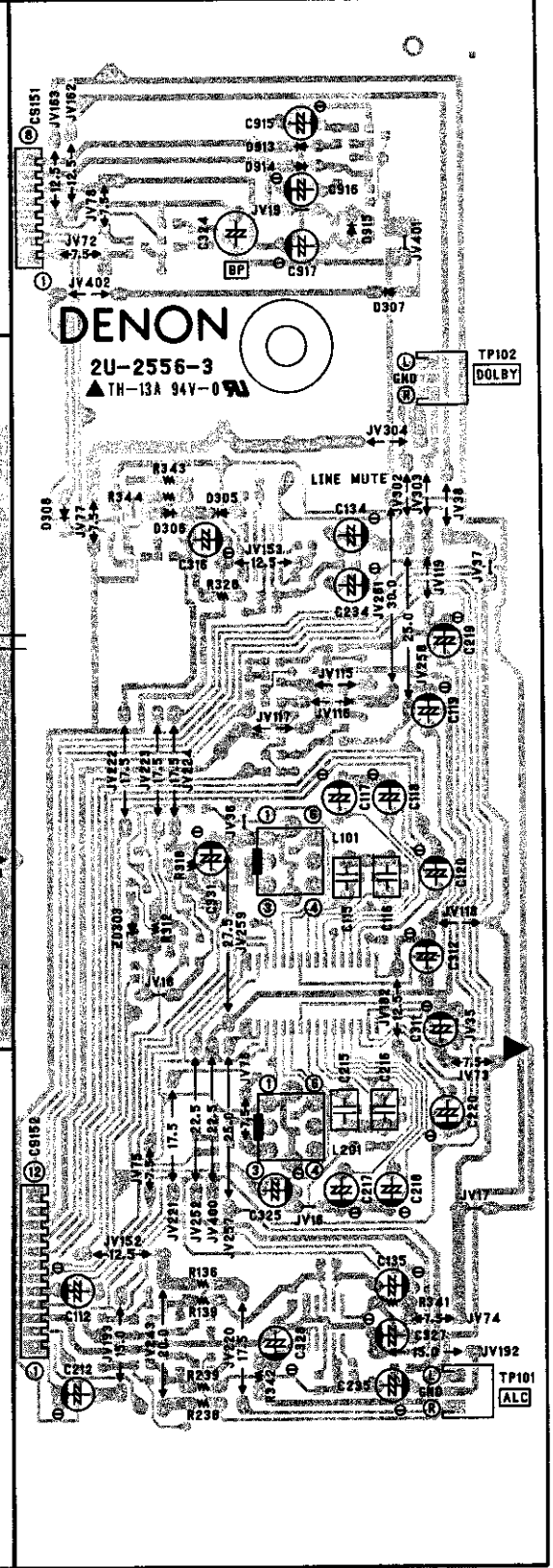

CASSETTE DECK SECTION

1 2 3 4 5 6 7 8

Pattern Side

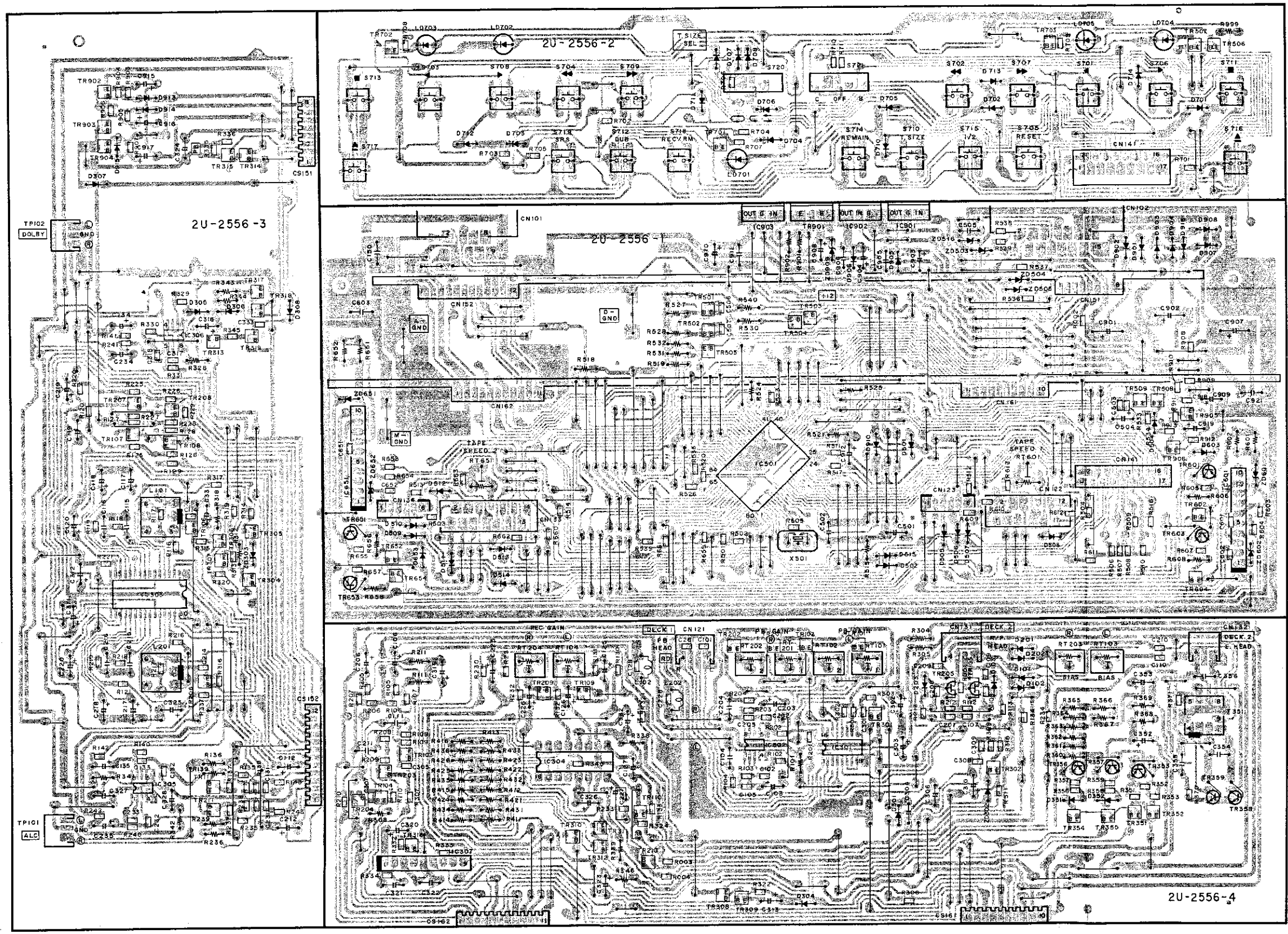

A
B
C
D
E

WIRING DIAGRAM

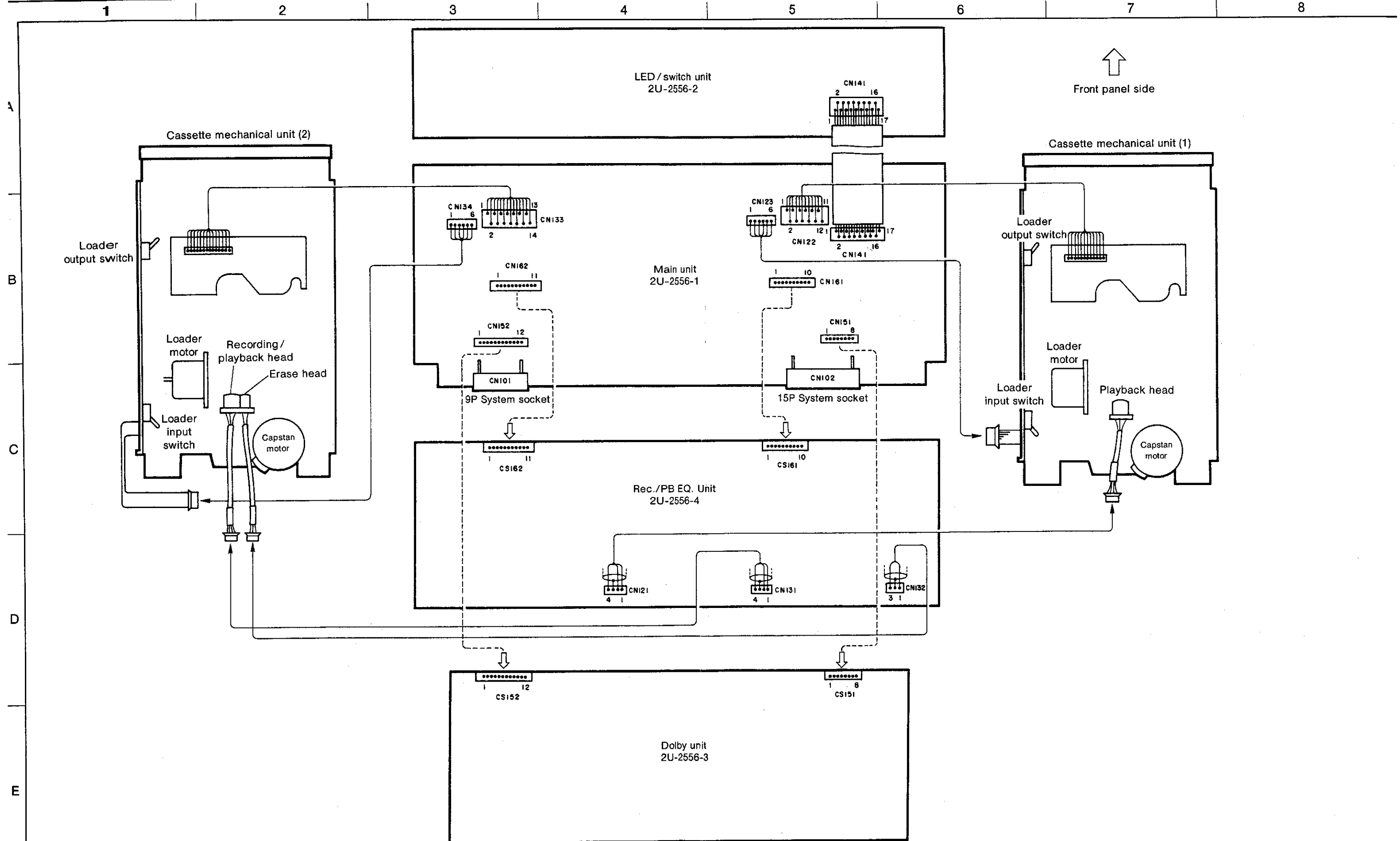

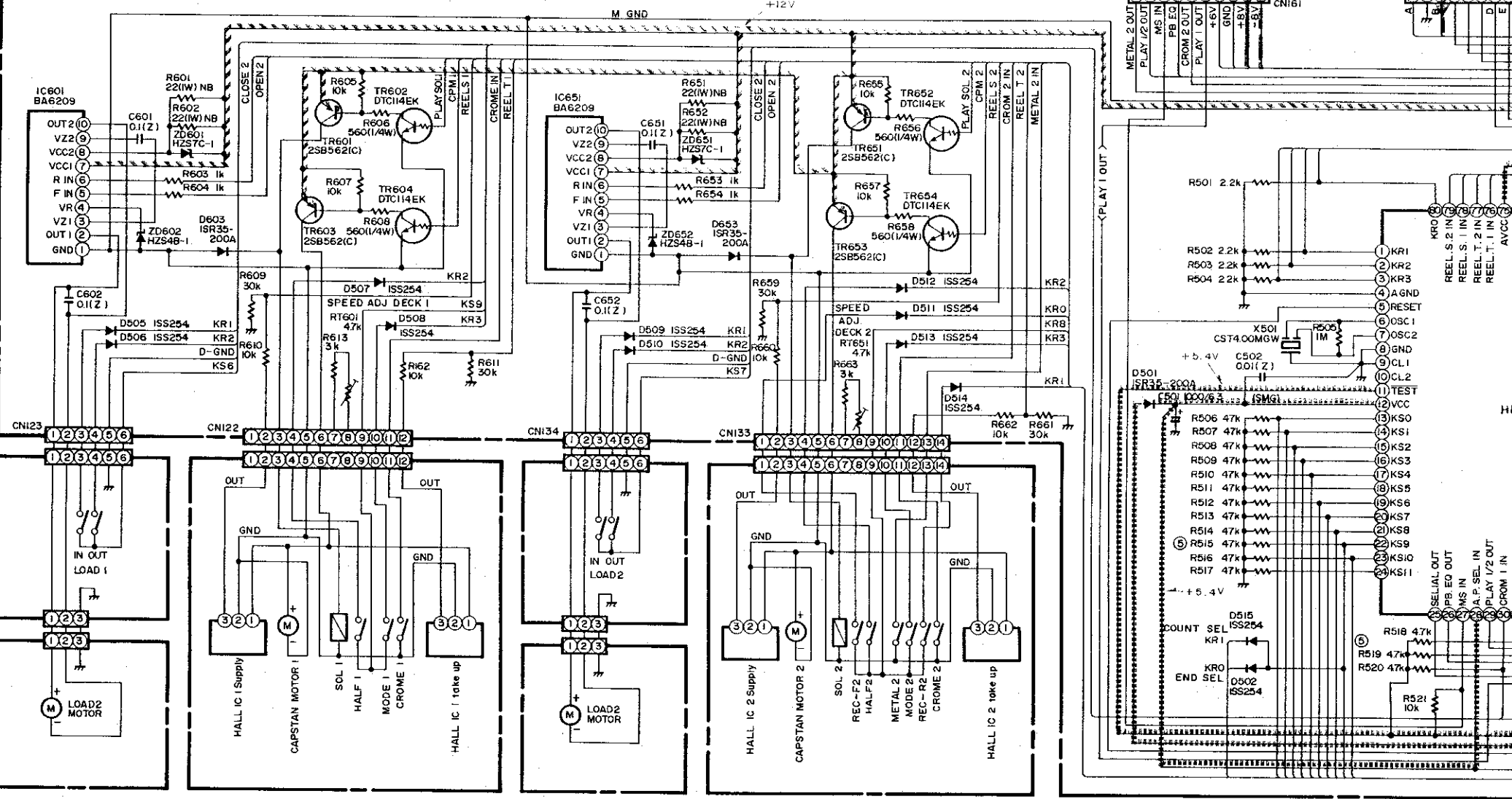
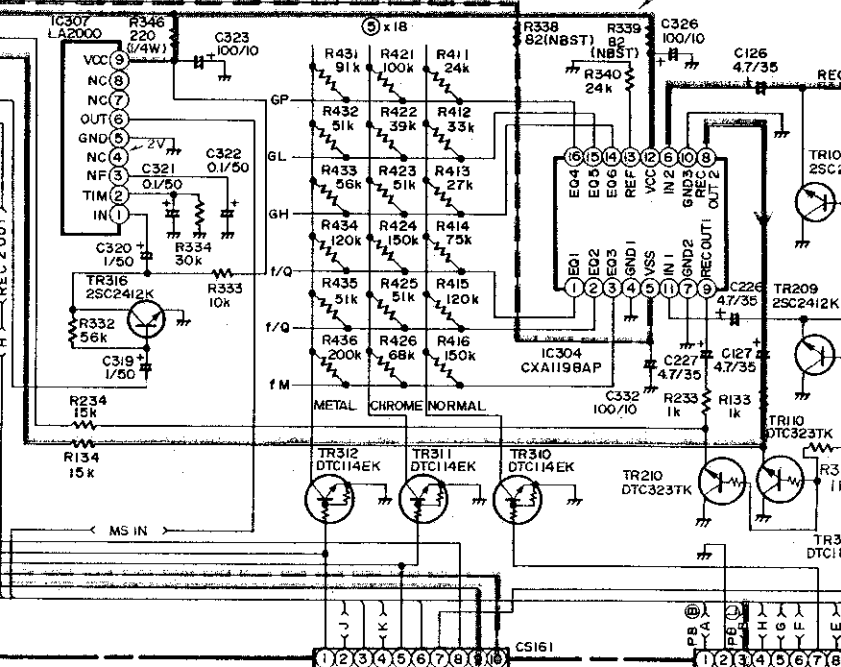
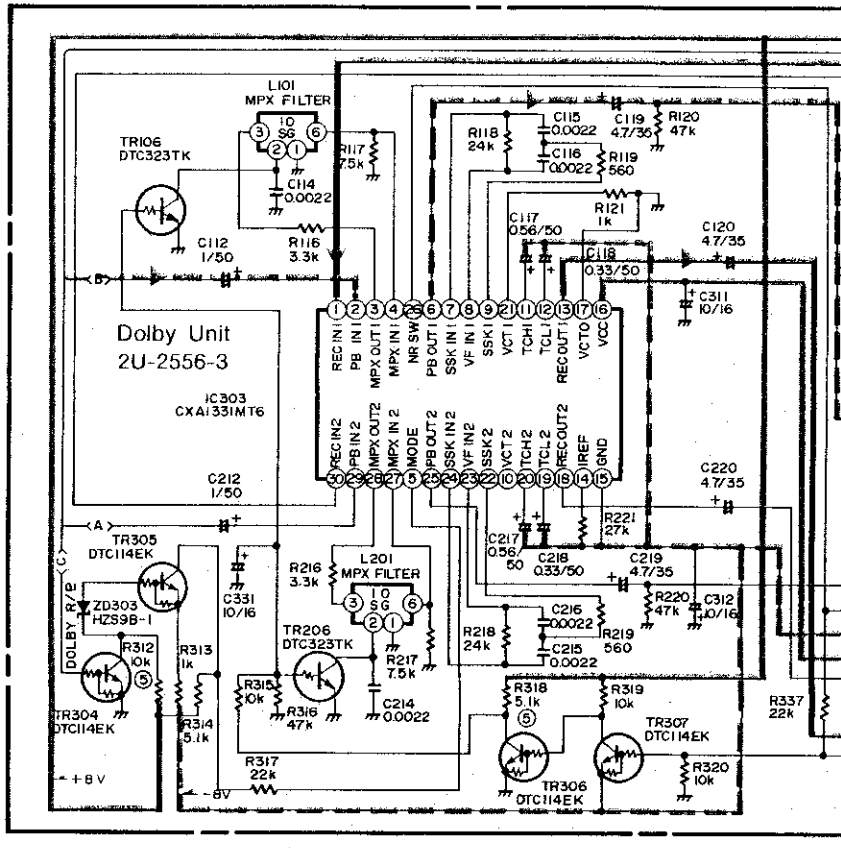
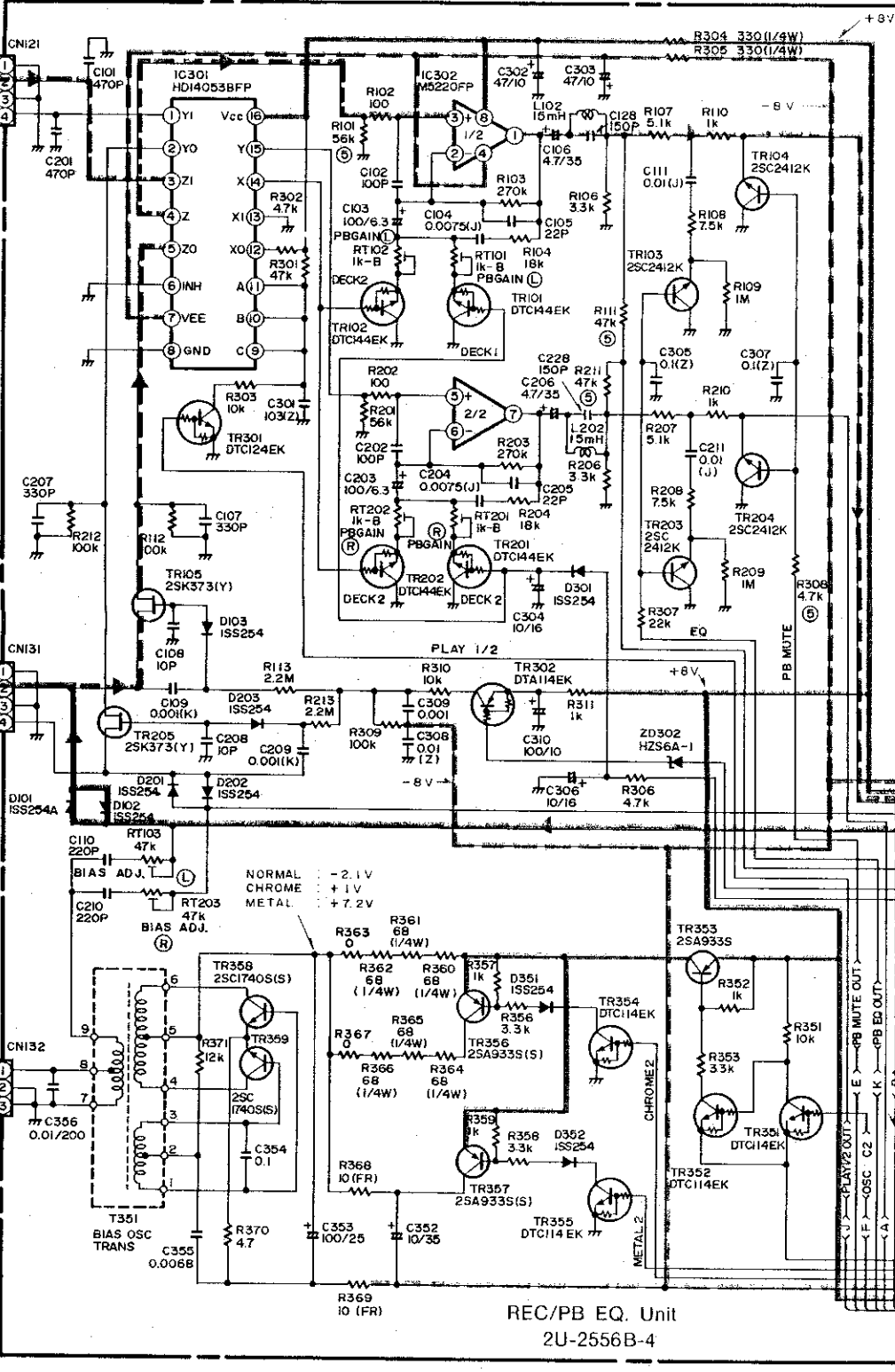
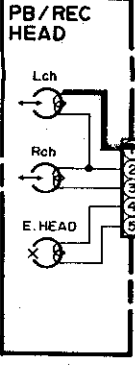
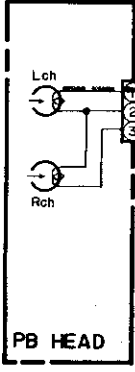

- Rec Line
- PB Line
- + 12V Line
- + 5.4V Line
- + B Line
- B Line
- + 5.4V Line

WARNING:
Parts marked with this symbol  have critical characteristics. Use ONLY replacement parts recommended by the manufacturer.

CAUTION:
Before returning the unit to the manufacturer, leakage current exceeds 0.5 mA defective.

WARNING:
DO NOT return the unit to the manufacturer.

SCHEMATIC DIAGRAM

CASSETTE DECK SECTION

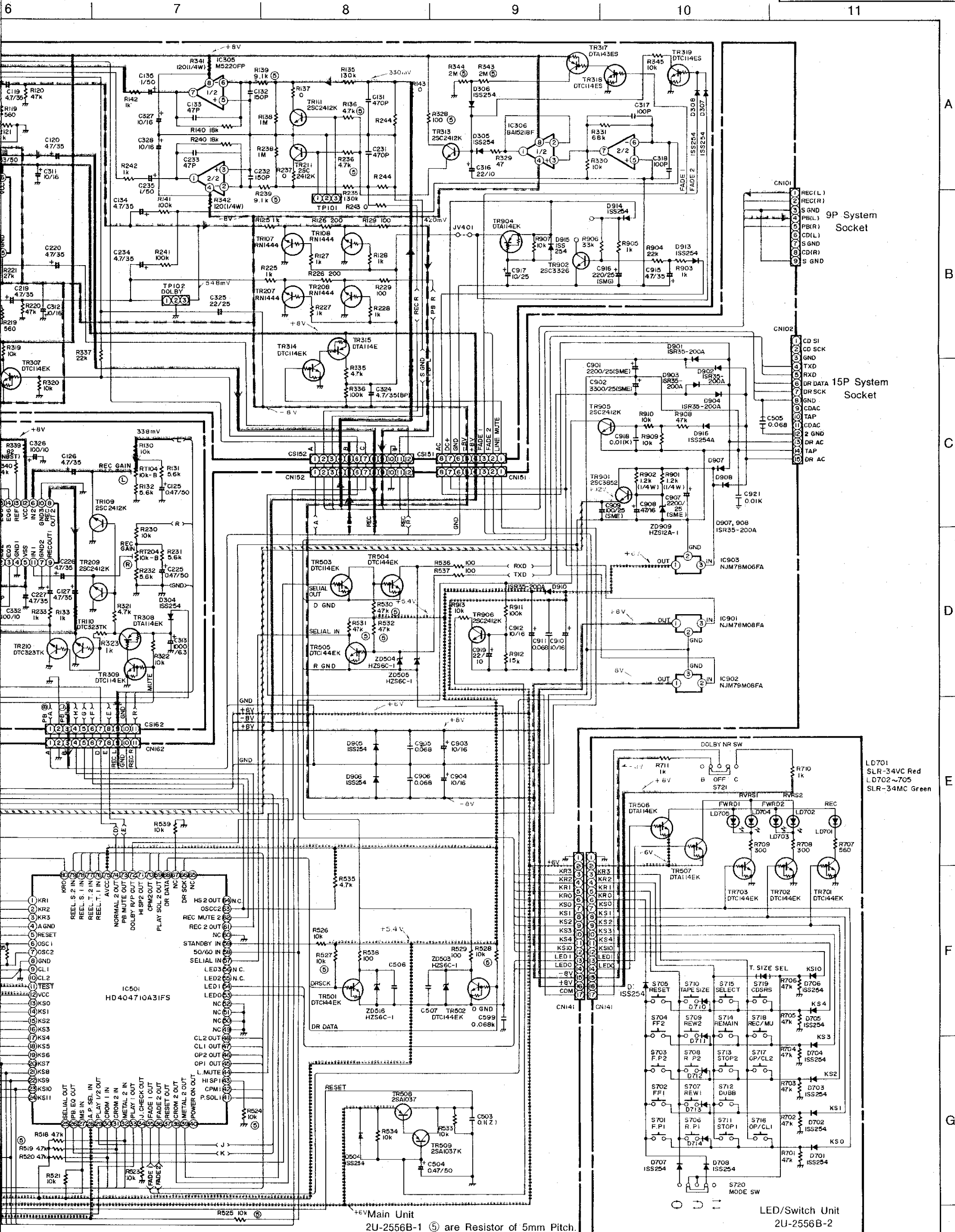

CAUTION:
Before returning the unit to the customer, make sure you make either (1) a leakage current check or (2) a line to chassis resistance check. If the leakage current exceeds 0.5 milliamperes, or if the resistance from chassis to either side of the power cord is less than 240 Kohms, the unit is defective.

WARNING
DO NOT return the unit to the customer until the problem is located and corrected.

NOTES
ALL RESISTANCE VALUES IN OHM K=1,000 OHM M=1,000,000 OHM
ALL CAPACITANCE VALUES IN MICRO FARAD P=MICRO-MICRO FARAD
EACH VOLTAGE AND CURRENT ARE MEASURED AT NO SIGNAL INPUT CONDITION.
CIRCUIT AND PARTS ARE SUBJECT TO CHANGE WITHOUT PRIOR NOTICE.

CASSETTE DECK SECTION

EXPLODED VIEW

PARTS LIST OF UDR-65 EXPLODED VIEW

Ref. No.	Part No.	Part Name	Remarks	Q'ty
● 1	2U- 2556 B	Cassette Deck Unit Ass'y		1 ^S
1-1	—	Main Unit		(1)
1-2	—	LED/SW Unit		(1)
1-3	—	Dolby Unit		(1)
1-4	—	Rec/PB EQ. Unit		(1)
2	254 4256 790	Chemicon 2200μF/25 V	C901,907	2
3	254 4257 702	Chemicon 3300μF/25 V	C902	1
● 4	411 1225 301	Main Chassis		1
5	124 0079 007	Felt Sheet		4
6	212 1078 906	Slide Switch(1-3)		2
● 7	105 1083 017	Rear Panel		1
● 8	412 3470 102	Spring Plate		1
● 9	412 3685 104	P.W.B Bracket		1
● 10	HM65	Cassette Mecha. Unit		1
11	449 0089 103	Mecha. Holder(F,L)		2
12	449 0090 105	Mecha. Holder(F,R)		2
13	449 0091 104	Mecha. Holder(R)		4
● 14	146 1449 306	Front Panel		1
15	—	—		—
16	143 0787 109	Lens(A)		2
17	143 0789 000	Lens(C)		1
18	113 1587 103	Play Button(1)		1
19	113 1588 102	Play Button(2)		1
20	113 1611 105	Slide Knob		2
21	009 0091 003	17 P FFC Cable		1
22	146 1461 203	Loader Panel(1)		1
23	146 1462 202	Loader Panel(2)		1
● 24	102 0537 015	Top Cover		1
★ 25	513 2120 002	Rating Sheet		1
26	204 8284 035	9 P System Socket		1
27	204 8284 022	15 P System Socket		1
★ 28	513 2158 003	Serial No. Sheet		1
● 29	412 3723 008	L. Angle		1
★ 30	445 0033 005	Wire Clamp Band		1
31	461 0758 065	Rubber Sheet		1
32	477 0224 031	SP Washer		2
SCREWS				
51	473 7015 018	Tapping Screw (S) 3×8	Black	18
52	473 7002 021	Tapping Screw (S) 3×8	Black	6
53	473 7500 044	Tapping Screw (P) 3×8	Black	2
54	473 3808 009	Tapping Screw (I) 3×25		8
55	473 7505 007	Tapping Screw (P) 2.6×8	Black	8
PACKING & ACCESSORIES (Not included EXPLODED VIEW)				
101	505 0154 095	Cabinet Cover		1
102	503 1074 000	Cushion		1
103	503 1075 106	Top Cushion		1
104	501 1705 108	Carton Case		1

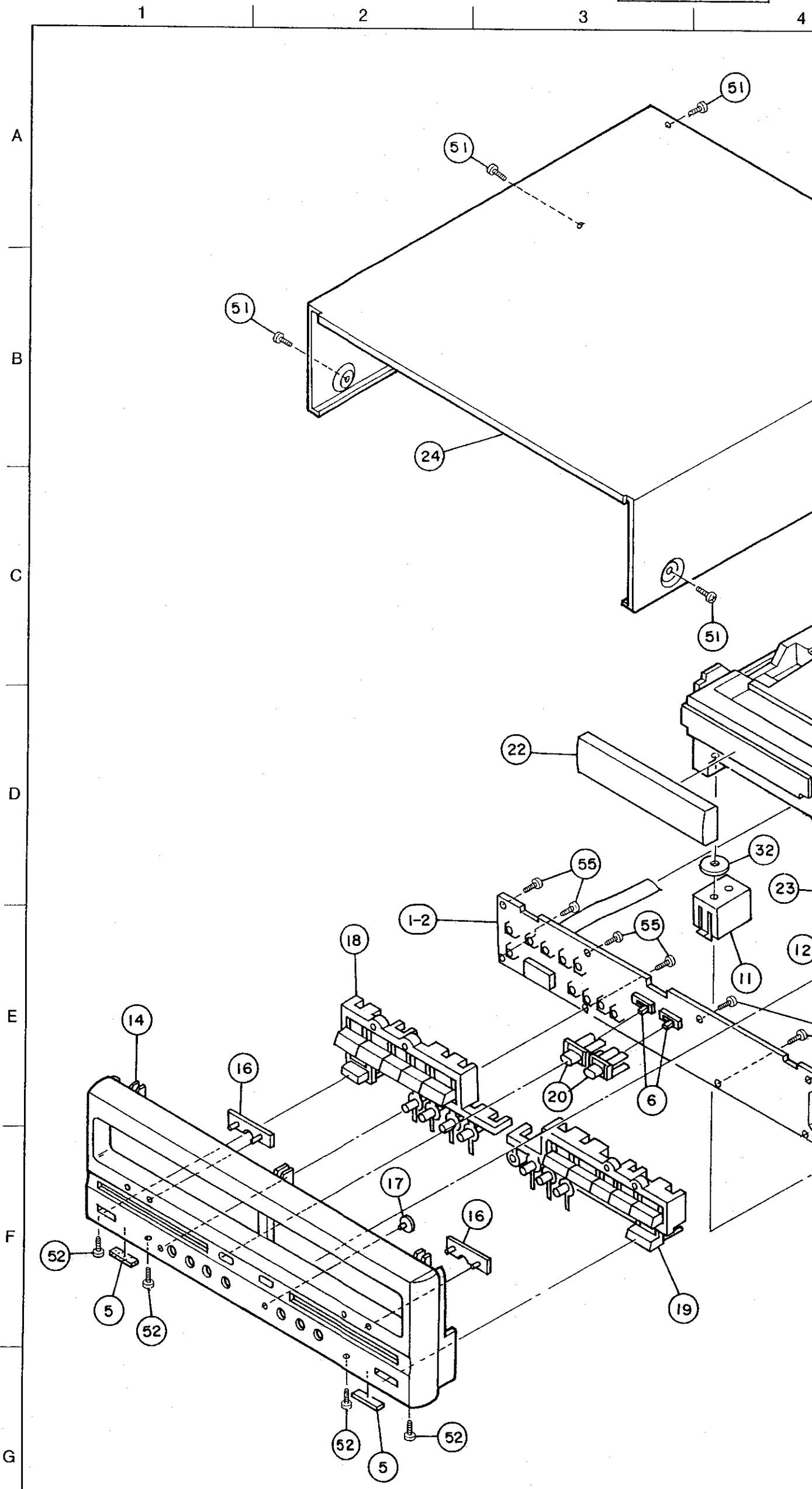

NOTE ON PARTS LIST

- Part indicated with the mark "●" are not always in stock and possibly to take a long period of time for supplying, or in some cases supplying of part may be refused.
- When ordering of part, clearly indicate "1" and "1" (i) to avoid mis-supplying.
- Ordering part without stating its part number can not be supplied.
- Part indicated with the mark "★" is not illustrated in the exploded view.

WARNING:

Parts marked with this symbol Δ have critical characteristics. Use ONLY replacement parts recommended by the manufacturer.

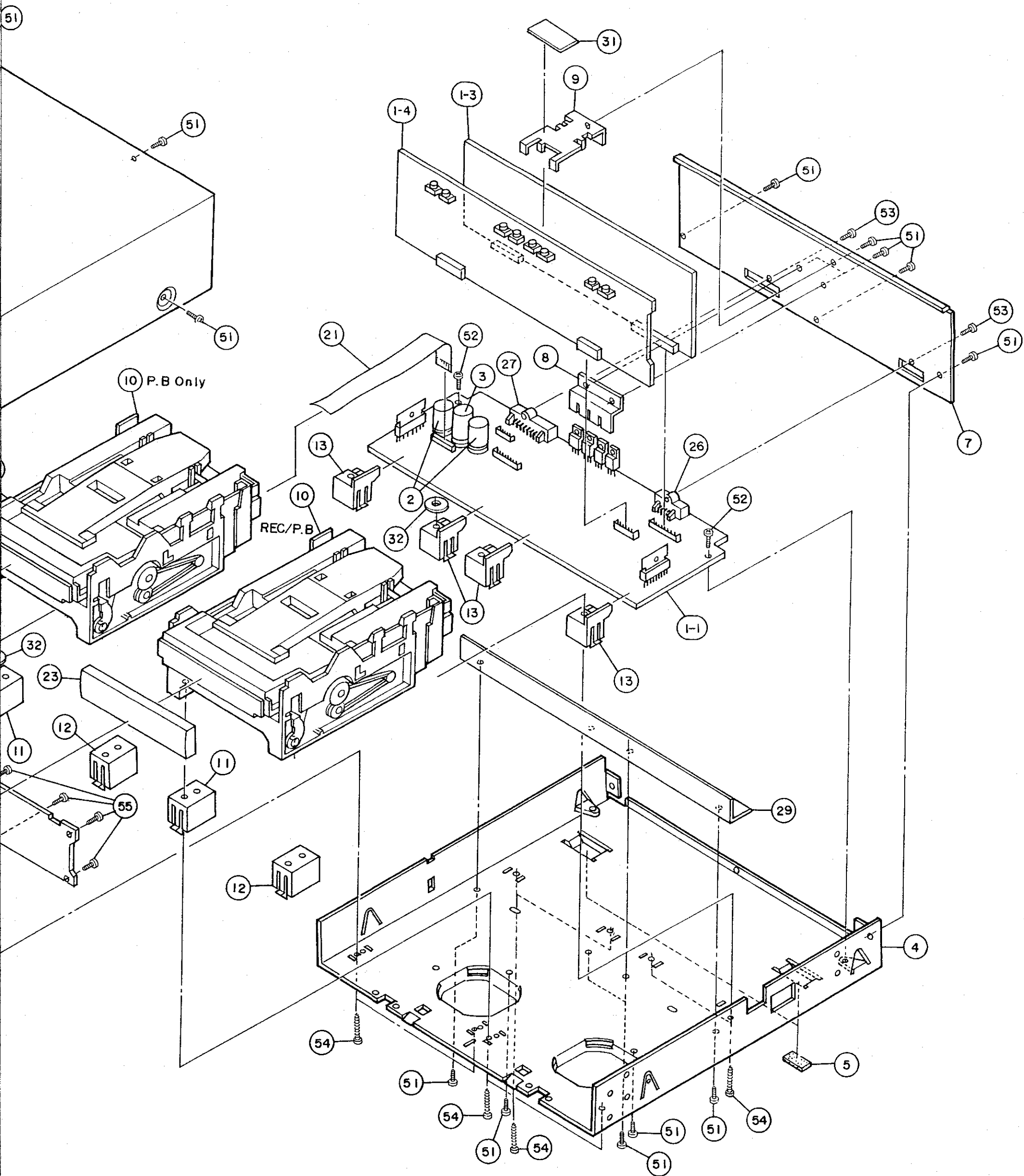

g, or in some case

CASSETTE MECHANISM : HM-65

CASSETTE DECK SECTION

HM-65R:REC/PB, HM-65P:PB ONLY PARTS LIST

Ref. No.	Part No.	Part Name	Remarks	Q'ty	Ref. No.	Part No.	Part Name	Remarks	Q'ty
★ 1	411 1163 612	Loading Mech. Ass'y		2	● 18	338 0166 001	Cassette Mech. (PB only) Ass'y	CRF-464	1
● 2	411 1156 409	Mech. Base Ass'y		2	● 19	412 3669 007	Shield Bracket		2
3	424 0183 000	Pulley Gear		2	● 20	412 3517 104	Shield Ring	PB only	1
4	423 0064 003	Belt		2	● 21	2U- 2600	P.W.B. Unit Ass'y		2
5	424 0182 001	Gear		2	★ 22	203 8334 005	5P EH-3P 4P PH Conn. Cord	REC/PB only	1
6	475 1119 110	Slit Washer	1.5X3.5X0.25	4	★ 22	203 4856 024	3P EH-4P PH Conn. Cord	PB only	1
7	433 0574 202	Push Lever		2	★ 23	203 0370 015	6 P PH-SAN Conn. Cord		2
● 8	412 3467 102	Push Bracket		2	24	—	—		
9	463 0708 008	Lever Spring		2	25	212 1077 004	Micro Slide Switch		4
10	463 0709 007	Push Bracket Spring		2	26	—	—		
11	433 0573 407	Clamper Arm		2	27	—	—		
12	463 0710 203	Clamper Spring		2	SCREWS				
13	431 0323 004	Clamper Press		4	51	—	—		
14	463 0707 009	Clamper Press Spring		4	52	471 3201 011	Bind Screw 2.6X4		4
15	431 0329 309	Loader Frame Ass'y	Loader Slider, C.Tray Ass'y	2	53	473 7500 015	Tapping Screw (P) 3X8		8
16	217 0158 000	Loading Motor		2	54	—	—		
17	421 0618 000	Motor Pulley		2	55	—	—		
● 18	338 0165 002	Cassette Mech. (REC/PB) Ass'y	CRF-463	1					

2U-2600 P.W.B. UNIT ASS'Y

Component Side

Pattern Side

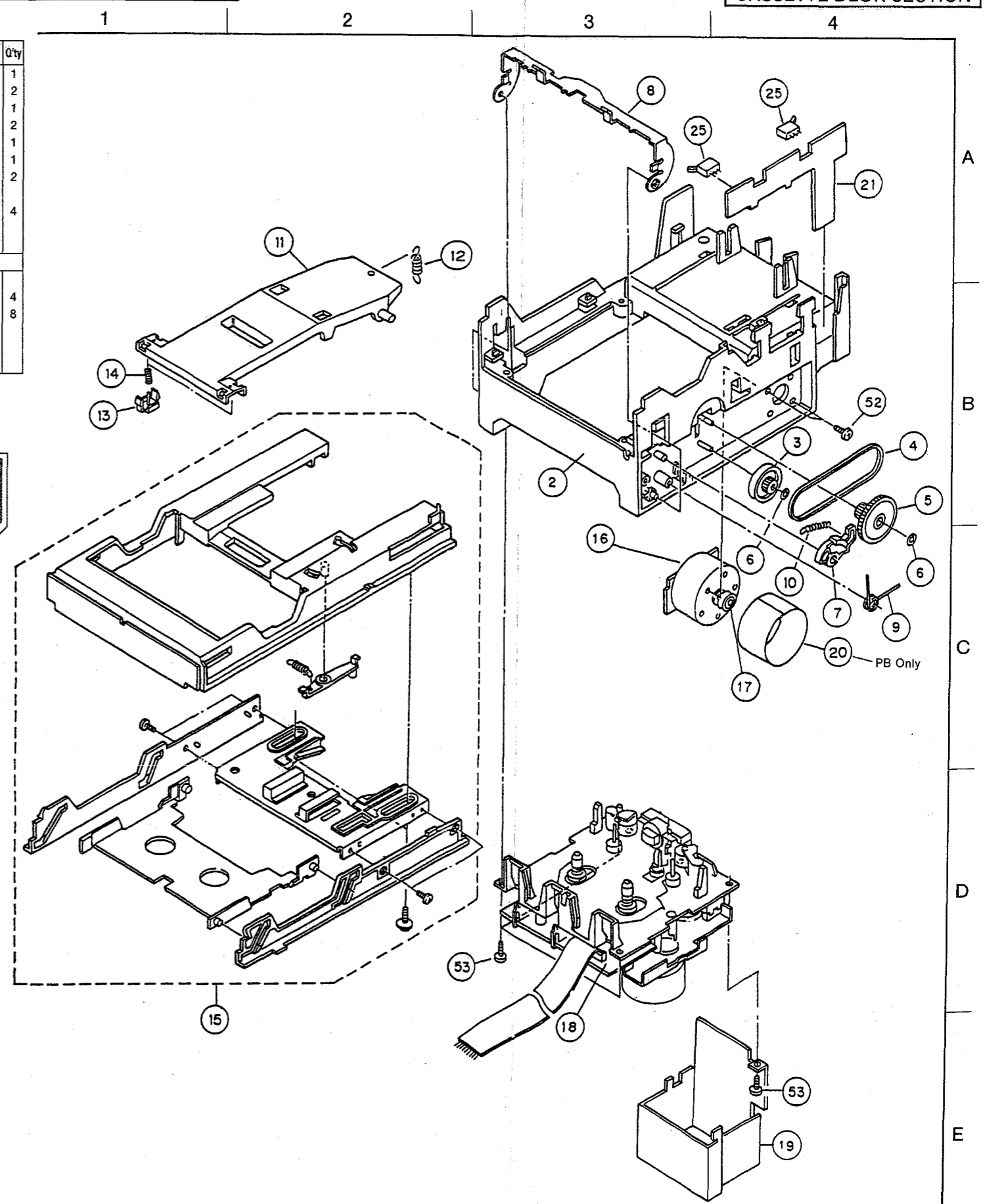
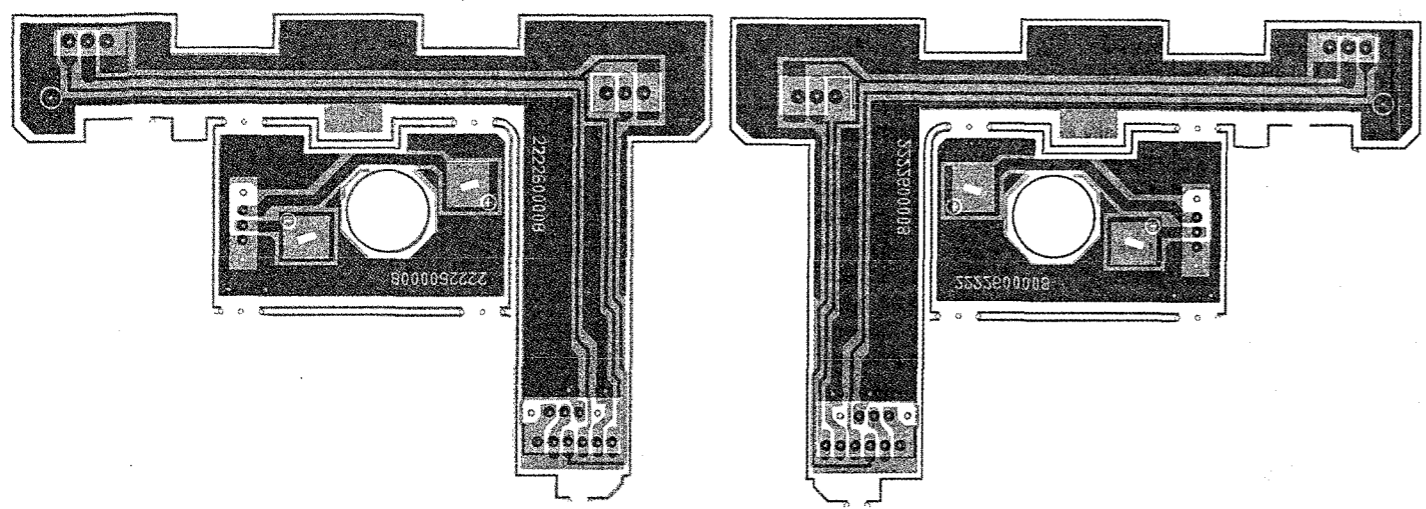

P.W.B. UNIT ASS'Y PARTS LIST

Ref. No.	Part No.	Part Name	Remarks	Q'ty
	—	(P.W.Board)		(2)
	204 0370 015	6 P PH-SAN Conn. Cord		2
	205 0409 031	3 P DIP Socket		4
	002 0042 006	3 C Ribon Wire Ass'y		2
	212 1077 004	Micro Slide Switch		4

CASSETTE DECK SECTION

DISASSEMBLY PROCEDURES

(Follow these procedures in reverse order to reassemble.)

1. Removing the loader frame assembly

- ① Pull the loader frame assembly out forwards until it stops.
- ② Insert a screwdriver with a narrow tip into the section indicated with the arrow, then lift the hook and pull the loader frame assembly out forwards.

NOTE: When reinserting the loader frame assembly, be careful not to damage the micro slide switch.

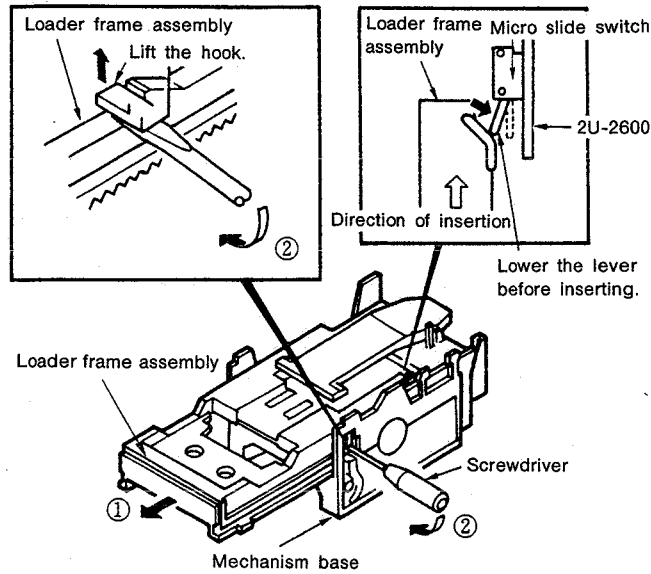

2. Removing the cassette mechanism

- ③ Remove the four screws fastening the cassette mechanism.
- ④ Pressing the push bracket in the direction of the arrow...
- ⑤ ...lift the cassette mechanism up and off.

NOTE: The push bracket may be deformed if the cassette mechanism is lifted without pressing the push bracket in the direction of the arrow. (The same is true when reassembling.) A deformed push bracket cannot be used.

After fastening the cassette mechanism with the screws, check that the push bracket moves (rotates) properly.

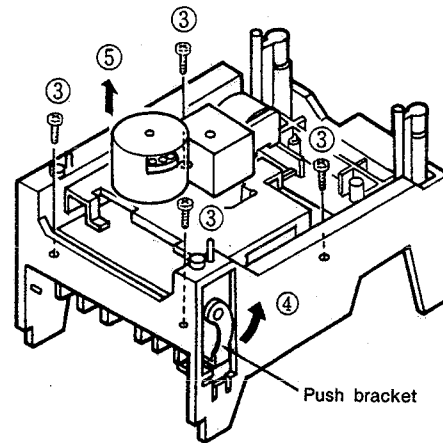

3. Removing the push bracket

Do this with the loader frame assembly and cassette mechanism removed.

- ⑥ Remove the lever spring.
- ⑦ Remove the push bracket spring using a spring catching rod, etc., through hole A.
- ⑧ Remove the push bracket.
 - (a) Remove the bar rings of the push bracket from the push bracket boss of the mechanism base in the order of left side (on which a spring is not attached), then right side.
 - (b) Bring out first the left then the right side from the mechanism base's push bracket insertion slot.

NOTE: Be careful not to deform the push bracket (do not forcibly disassemble or assemble it). A deformed push bracket cannot be used.

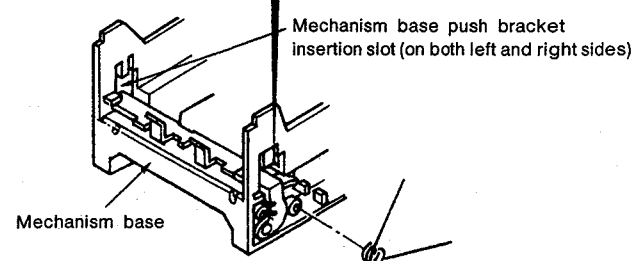
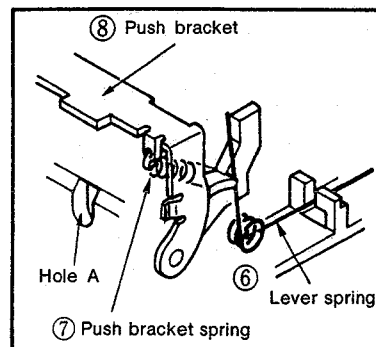

REC/PB Mecha.:338 0165 002 (CRF-463)

CASSETTE MECHANISM PARTS LIST PB only Mecha.:338 0166 001 (CRF-464)

Ref. No.	Part No.	Part Name	Remarks	Qty	Ref. No.	Part No.	Part Name	Remarks	Qty
1	948 0000 126	Holder Head Ass'y for REC/PB	22-093-4269	1	64	948 0004 737	Back Tention Spring	01-081-4333	4
1	948 0000 113	Holder Head Ass'y for PB only	22-093-4067	1	65	948 0004 740	Pinch Roller Return Spring	01-082-4253	2
2	948 0000 207	Head Frame	22-219-1026	2	66	948 0004 753	Pinch Roller Hold Spring	01-082-4262	2
3	948 0000 304	Head Lever	22-259-2012	2	67	948 0004 766	Spring	01-082-4337	2
4	948 0000 401	Spring Azimuth	16-160-4032	2	68	—	—	—	—
5	948 0000 508	Assist Arm Ass'y	22-093-4053	2	69	948 0004 779	Pinch Roller Return Spring	01-082-4254	2
6	948 0000 605	Head Arm Gear	22-239-4020	2	70	948 0004 782	Pinch Roller Hold Spring	01-082-4261	2
7	948 0000 702	Stopper Plate	22-119-4283	2	71	948 0010 608	FR Arm Spring	01-080-4392	2
8	—	—	—	—	72	948 0006 515	Spring	01-081-4073	2
9	—	—	—	—	73	948 0006 528	Spring	01-081-4309	2
10	948 8000 809	Pinch Roller (L) Ass'y	22-093-4149	2	81	948 0004 805	Azimuth Screw	03-300-4056	4
11	948 8000 906	Head Slide Chassis	22-112-2022	2	82	948 0004 818	Screw	PGSL20A2006	2
12	948 0001 002	Pinch Roller (R) Ass'y	22-093-4150	2	83	948 0004 821	Head Arm Hold Screw	03-300-4043	2
13	948 0010 200	Play Arm (L) Ass'y	22-239-3257	2	84	948 0004 834	Screw	PGSD10A2004	4
14	948 0010 307	Play Gear	22-222-4282	4	85	948 0004 847	Screw	PGSD20A2016	2
15	948 0010 213	Play Arm (R) Ass'y	22-239-3256	2	86	948 0004 850	Screw	PGSL15A2608	6
16	948 0001 400	OS Chassis	22-210-1023	2	87	948 0004 863	Motor Hold Screw	PBE13913	4
17	948 0001 507	Sub Reel (L) Ass'y	22-093-3071	2	88	948 0004 876	Screw	PGSL10A12608	2
18	948 0001 604	Solenoid Ass'y	22-093-4417 or 07-W021C	2	101	—	—	—	—
19	—	Wire	22-072-4105	2	102	948 0004 915	Washer	PGWP16x040040	2
20	948 0001 808	RVS Arm	22-239-3010	2	103	948 0004 928	Washer	PGWP26x042013	8
21	948 0001 905	FF Gear	22-222-4048	2	104	—	—	—	—
22	948 0002 001	FR Arm Ass'y	22-093-4061	2	105	—	—	—	—
23	948 0002 108	FR Pulley Ass'y	22-093-3060	2					
24	948 0002 205	FR Belt	22-083-4059	2					
25	948 0002 302	Metal	22-262-4033	2					
26	948 0005 503	Flywheel (L) Ass'y	22-093-3360	2					
27	948 0002 315	Metal	16-262-4031	2					
28	948 0002 506	Brake Arm	22-239-3028	2					
29	948 0001 510	Sub Reel (R) Ass'y	22-093-4151	2					
30	948 0002 603	Trigger Arm	22-268-3008	2					
31	948 0002 700	Cam Gear	22-221-2090	2					
32	948 0005 600	Metal	PBE16449	2					
33	948 0010 404	Flywheel (R) Ass'y	22-220-3386	2					
34	948 0002 331	Metal	16-262-4030	2					
35	948 0002 849	Wire (14 P) for REC/PB	16-072-4238	1					
35	948 0002 852	Wire (12 P) for PB only	22-072-4098	1					
36	948 0002 904	Wire Holder	16-219-2382	2					
37	948 0003 000	P.W.B. Board	22-070-3261	2					
38	948 0005 804	Mode Switch	04-MPU10101MMB0	2					
39	948 0003 204	Leaf Switch for REC/PB	04-MTS10045MVJ0	5					
39	948 0003 204	Leaf Switch for PB only	04-MTS10045MVJ0	2					
40	948 0003 301	Hall IC(LB9051A)	00-LB9051A	4					
41	—	Flywheel Bracket	22-119-2441	2					
42	—	—	—	—					
43	948 0010 501	Motor Ass'y	22-093-4532	2					
44	—	Wire	16-072-4056	2					
45	948 0006 104	Main Belt	02-084-4078	2					
46	948 0003 806	P.W.B. Board	22-070-4046	2					
47	205 0234 057	5P EH Sid Conn Base REC/PB	—	1					
47	204 0234 031	3P EH Sid Conn Base PB only	—	1					
48	948 0004 106	Cushion Rubber	PBE13360	4					
49	—	—	—	—					
50	—	—	—	—					
51	948 0004 300	Reel (A)	22-228-3210	4					
52	948 0004 407	Reel (B)	22-228-3211	4					
53	948 0004 504	Reel Pulley	22-223-3212	4					
61	948 0004 708	Spring Head Hold	01-080-4251	2					
62	948 0004 711	Head Lever Spring	01-080-4249	2					
63	948 0004 724	Spring	01-082-4250	2					

CASSETTE DECK SECTION

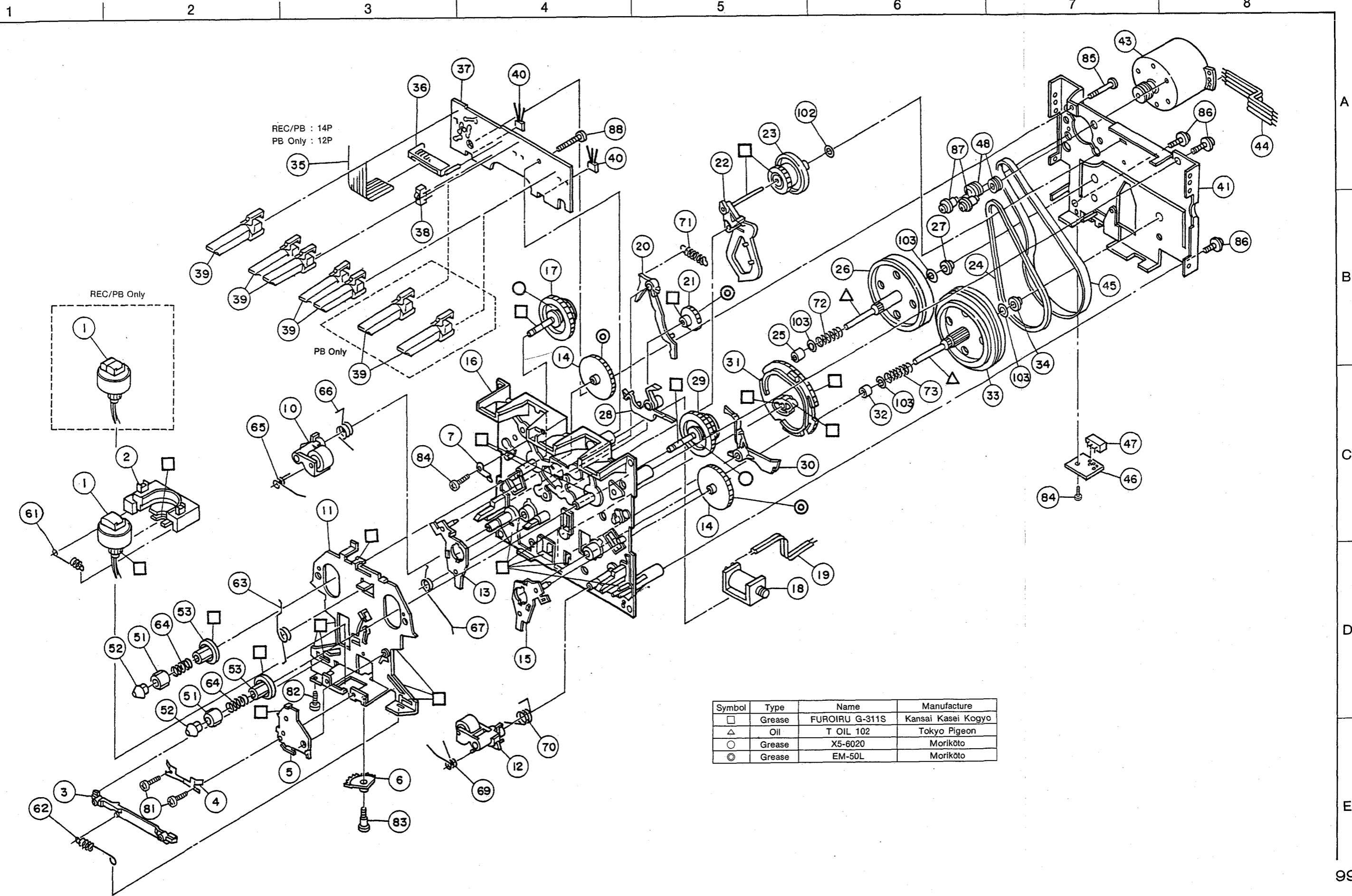

SPEAKER SECTION

EXPLODED VIEW

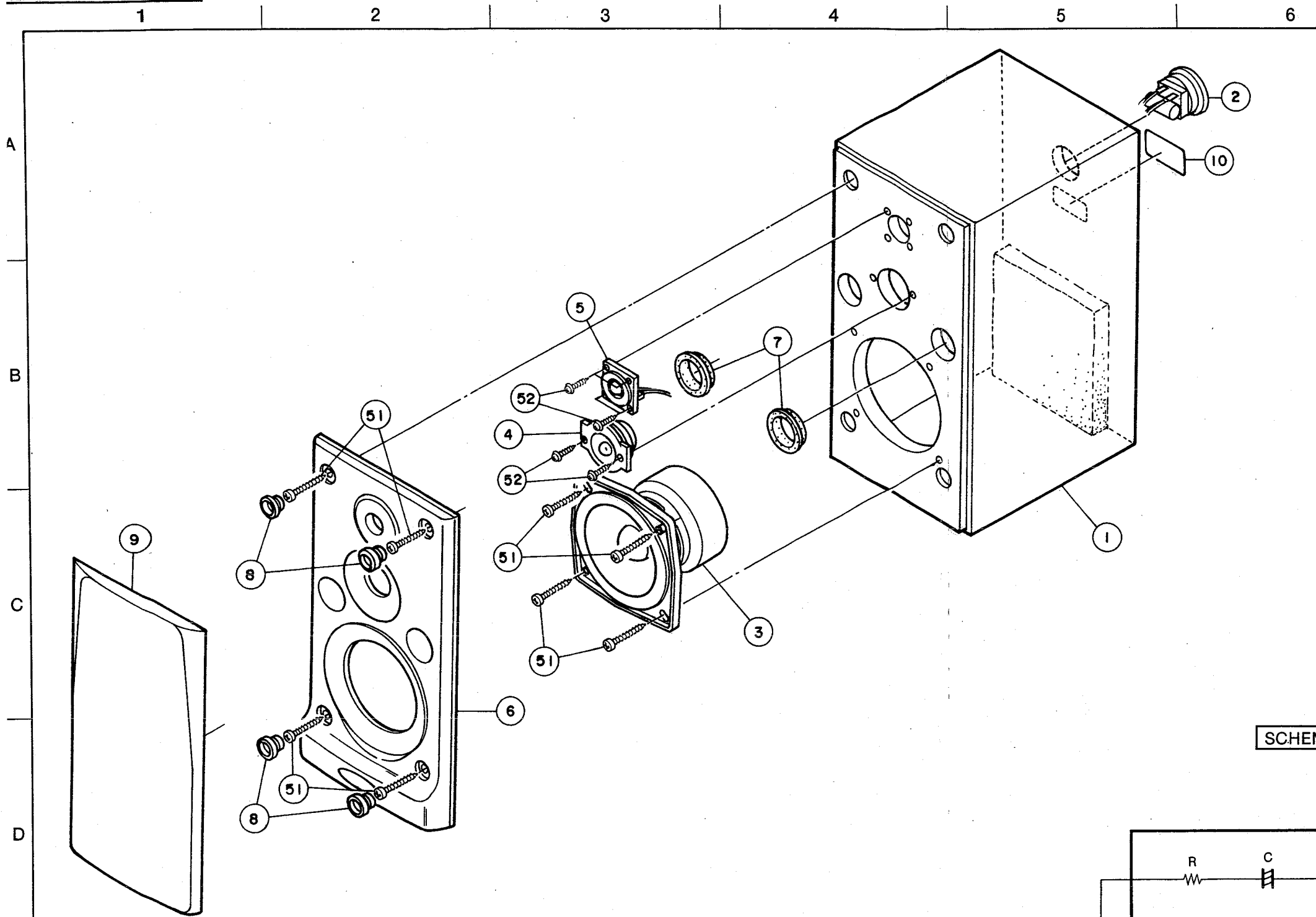

PARTS LIST OF USC-65 EXPLODED VIEW

Ref. No.	Part No.	Part Name	Remarks	Qty
● 1	GEN 7510 H1	Cabinet Sub Ass'y		2
2	349 9020 106	Net Work Ass'y		2
● 3	302 9023 007	Speaker 12RW24 Ass'y	Woofers	2
3-1	129 9020 104	WF. Packing		(2)
● 4	304 9224 002	Speaker 50RT45 Ass'y	Tweeter	2
4-1	129 9021 103	TW. Packing		(2)
● 5	304 9025 001	Speaker PT-10 Ass'y	S.Tweeter	2
● 6	146 9276 209	Front Panel		2
7	129 9019 005	Urethane Spacer		4
8	402 9006 007	Holder		8
● 9	103 9184 103	Grille Board Ass'y		2
10	513 9335 104	Rating Sheet		2
11	513 2158 003	Serial No. Sheet		2
★ 12	513 2159 002	Green Point Label		1
SCREWS				
51	473 0410 021	Tapping Screw (1) 4X20	Black	16
52	473 0309 022	Tapping Screw (1) 3X16	Black	12
53				
PACKING & ACCESSORIES (Not included EXPLODED VIEW)				
101	504 9118 039	Stylen Paper		2
102	505 9122 031	Poly Cover		2
103	505 9119 002	Envelope		1
104	009 9022 015	Output Cord Ass'y	L=2 m	2
105	503 9243 008	Cushion Ass'y		1
106	501 9237 050	Carton Case		1
107				
NETWORK ASS'Y (Part No.: 349 9020 106)				
71	205 0821 004	2 P Terminal Ass'y		2
72	009 9026 040	1 P Wire Ass'y (Red)	Woofers(+)-L=330	2
73	009 9027 049	1 P Wire Ass'y (Black)	Woofers(-)-L=330	2
74	009 9035 002	2 P Wire Ass'y (Orange/White)	Tweeter/S.Tweeter (+)-L=170/300	2
75	009 9041 009	2 P Wire Ass'y (Blue/Yellow)	Tweeter/S.Tweeter (-)-L=170/300	2
76	254 4447 004	Chemicon 2.2μF/50V (Bipole)	CE04W1H2R2MBP	2
77	243 2010 006	Wire Wound Resistor 2.7 ohm/5W	RW98A3H2R7K	2
78				

SCHEMATIC DIAGRAM

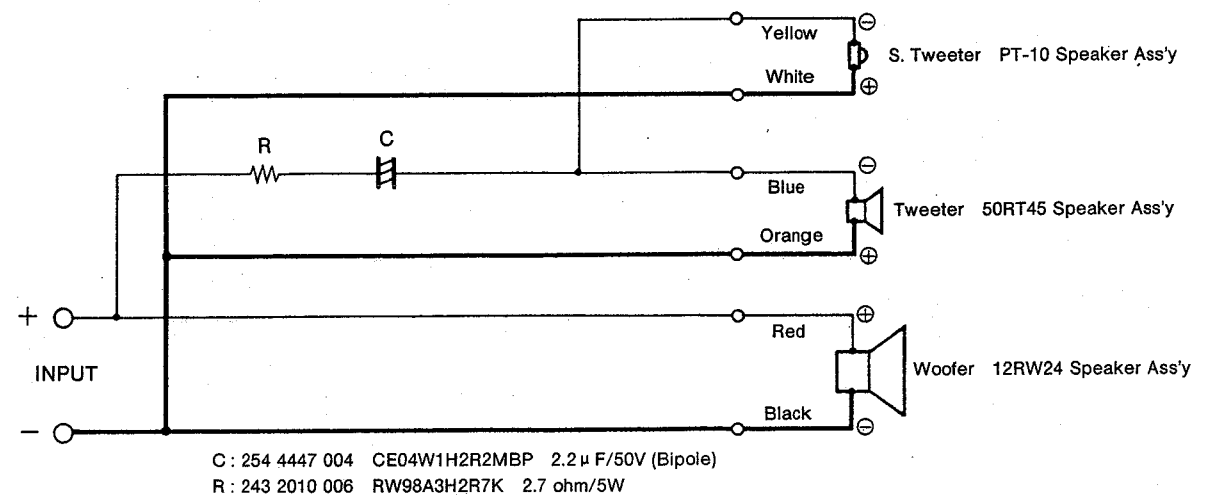

NOTE ON PARTS LIST

- Part indicated with the mark "●" are not always in stock and possibly to take a long period of time for supplying, or in some case supplying of part may be refused.
- When ordering of part, clearly indicate "1" and "1" (i) to avoid mis-supplying.
- Ordering part without stating its part number can not be supplied.
- Part indicated with the mark "★" is not illustrated in the exploded view.

WARNING:

Parts marked with this symbol Δ have critical characteristics. Use ONLY replacement parts recommended by the manufacturer.

SPEAKER SECTION

NETWORK Ass'y

(349 9020 106)

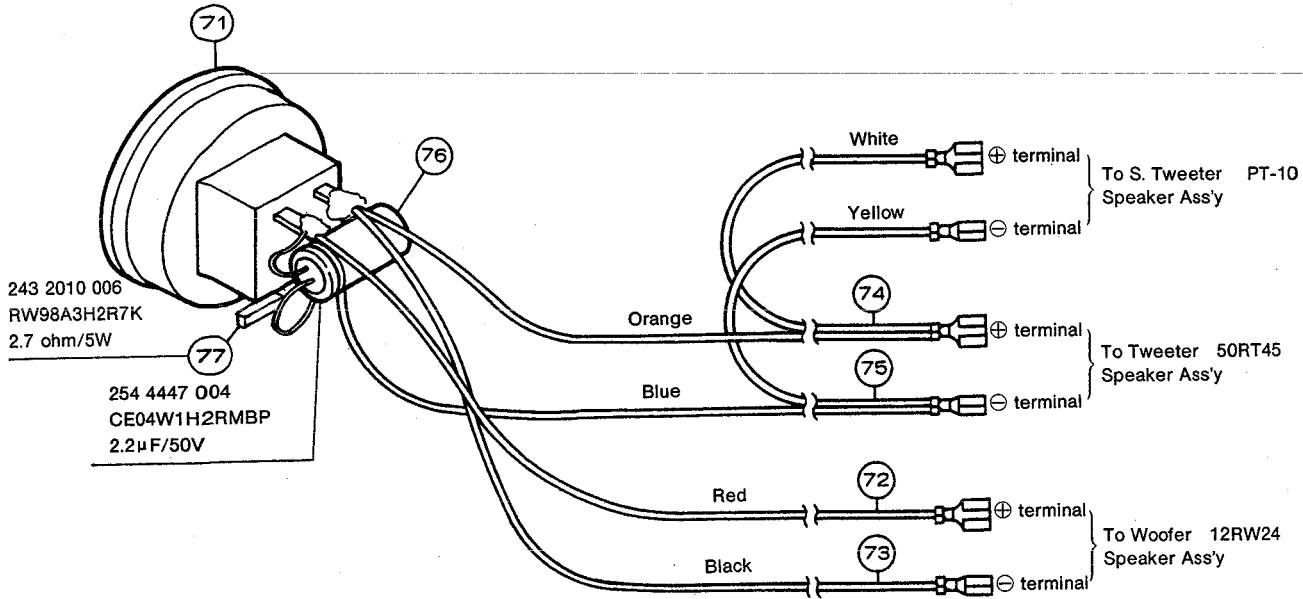

WIRE FORMING

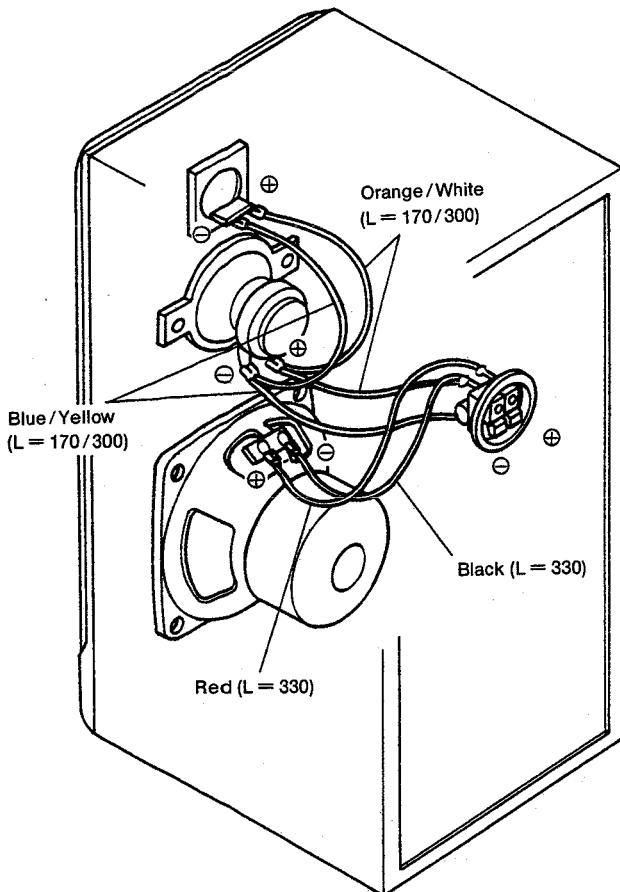

- ① Place so that the network assembly has the red terminal (+) on the right side, then attach.
- ② For connections to the super tweeter and the tweeter, connect the orange/white leads to the (+) side (length = 170/300mm) and the blue/yellow leads (length = 170/300mm) to the (-) side.
- ③ For the connections to the woofer, connect the red lead (length = 330mm) to the (+) side and the black lead (length = 330mm) to the (-) side.