

# DENON

For U.S.A., Canada, U.K.,  
Europe & Asia models

Hi-Fi Personal Component System

## SERVICE MANUAL

# MODEL UD-M50

### STEREO CD RECEIVER

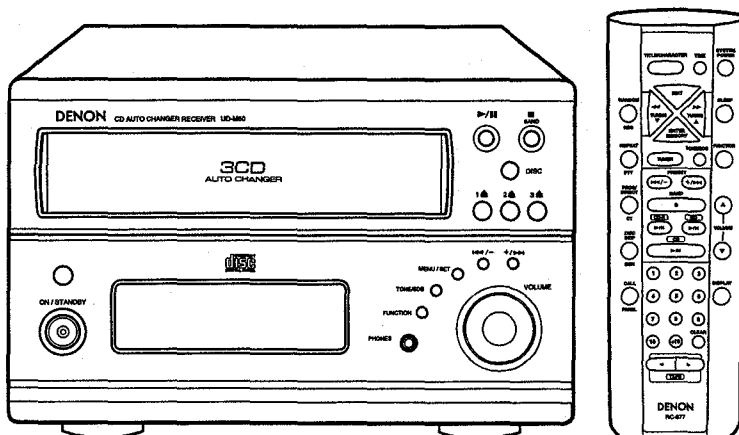

#### — TABLE OF CONTENTS —

SPECIFICATIONS .....	2
DISASSEMBLY .....	3-5
DISASSEMBLING CD MECHA .....	6
ASSEMBLING CD MECHA .....	7-10
BLOCK DIAGRAM .....	11
ADJUSTMENT .....	12-14
SEMICONDUCTORS .....	15-19
PRINTED WIRING BOARD .....	20-25
NOTE FOR PARTS LIST .....	26
PARTS LIST OF P.W.B. UNIT ASS'Y .....	26-33
PARTS LIST OF EXPLODED VIEW .....	34
EXPLODED VIEW .....	35
EXPLODED VIEW OF CD MECHANISM UNIT .....	36
PARTS LIST OF CD MECHANISM UNIT .....	37
WIRING DIAGRAM .....	38
SCHEMATIC DIAGRAMS .....	39-42
PACKING VIEW .....	43
PARTS LIST OF PACKING & ACCESSORIES .....	43

• Some illustrations using in this service manual are slightly different from the actual set.

## NIPPON COLUMBIA CO., LTD.

## SAFETY PRECAUTIONS

The following check should be performed for the continued protection of the customer and service technician.

### LEAKAGE CURRENT CHECK

Before returning the unit to the customer, make sure you make either (1) a leakage current check or (2) a line to chassis resistance check. If the leakage current exceeds 0.5 milliamps, or if the resistance from chassis to either side of the power cord is less than 460 kohms, the unit is defective.

## SPECIFICATIONS

### RECEIVER SECTION

Reception frequency band:	FM: 87.5 MHz - 108.0 MHz AM: 520 kHz - 1710 kHz (U.S.A. & Canada model) 522 kHz - 1611 kHz (Europe, U.K. & Asia models)
Reception sensitivity:	FM: 1.5 $\mu$ V/75 $\Omega$ /ohms AM: 20 $\mu$ V
FM stereo separation:	35 dB (1 kHz)
Rated output power:	30 W + 30 W (6 $\Omega$ /ohms, 1 kHz, T.H.D. 10 %)
Audio input/output jacks:	LINE1 input/output jacks, LINE2 input/output jacks, PRE OUT (with STEREO/MONO selector switch) jack, 3.5 mm headphones jack

### CD PLAYER SECTION

Wow & flutter:	Below measurable limits ( $\pm 0.001$ % W.peak)
Sampling frequency:	44.1 kHz
Optical source:	Semiconductor

### CLOCK, TIMER SECTION

Clock system:	Power source synchronous system
Timer functions:	Everyday timer (1 setting) Once timer (1 setting) Sleep timer (maximum 60 min.)

### GENERAL

Power supply:	AC 120 V, 60 Hz (U.S.A. & Canada model) AC 230 V, 50 Hz (Europe, U.K. & Asia models)
Power consumption:	70 W (U.S.A. & Canada model) 65 W (Europe, U.K. & Asia models)
Maximum external dimensions:	210 (W) $\times$ 135 (H) $\times$ 381 (D) mm (8-17/64" $\times$ 5-5/16" $\times$ 15") (including feet, controls and terminals)
Mass:	5.5 kg (12 lbs. 2 oz)

### REMOTE CONTROL UNIT (RC-877)

Remote control system:	Infrared pulse
Number of buttons:	39
Power Supply:	Two DC 1.5 V R03/AAA batteries
Maximum external dimensions:	61 (W) $\times$ 188 (H) $\times$ 26 (D) mm (2-13/32" $\times$ 7-13/32" $\times$ 1-1/32")
Mass:	120 g (4.2 oz) (including batteries)

\* Maximum dimensions include controls, jacks, and covers.  
(W) = Width, (H) = Height, (D) = Depth

\* For improvement purposes, specifications and functions are subject to change without advanced notice.

## DISASSEMBLY

( Follow the procedure below in reverse order when reassembling )

### Top Cover

1. Remove 2 screws ① on both sides.
2. Remove 2 screws ② fixing the Trans. Cover to detach it.
3. Remove 7 screws ③ on the rear.
4. Detach the Top Cover as shown in the arrow direction.

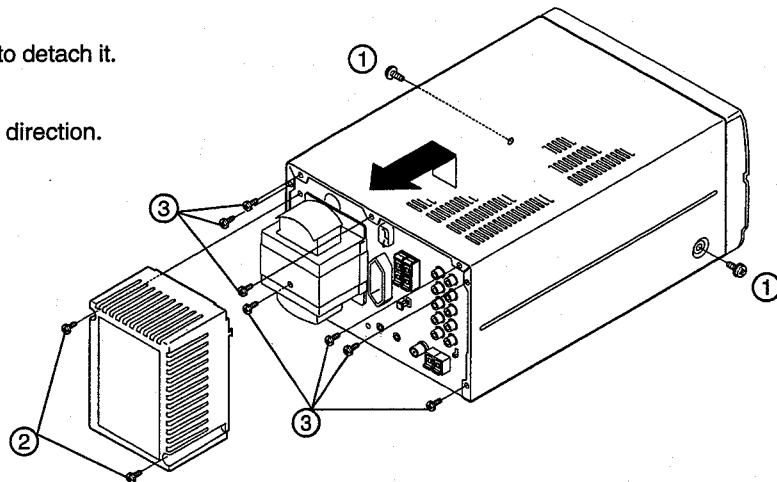

### Front Panel

1. Remove 2 bottom screws ④ from the Front Panel.
2. Detach the Front Panel with releasing 2 hooks on the top.

Note: Detach the Front Panel with directing it upward. Because the Knob Cap (B) and Spring Plate become free, pay attention not to lose them. (They are inserted and fastened between the Front Panel and Inner Panel.)

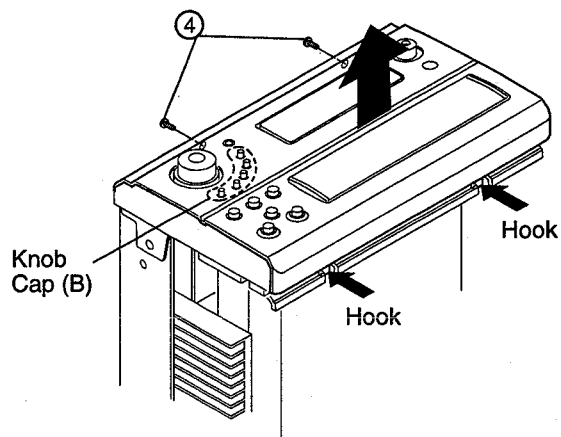

### Inner Panel

1. Remove 2 bottom screws ⑤ from the Inner Panel.
2. Remove 2 screws ⑥ fixing the CD Mecha.
3. Detach the Inner Panel to the arrow direction.
4. Disconnect 2 connectors coming from Display P.W.B.

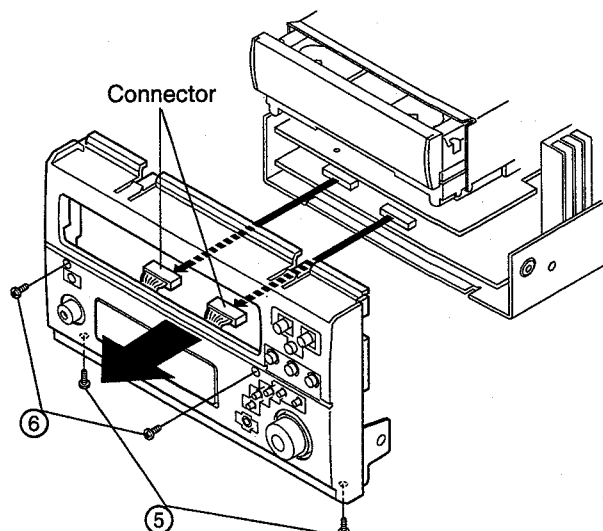

## CD Mecha.

1. Remove 4 screws ⑦ fixing the CD Mecha.
2. Remove 1 FFC.
3. Lift up the CD Mecha., and disconnect 2 connectors.

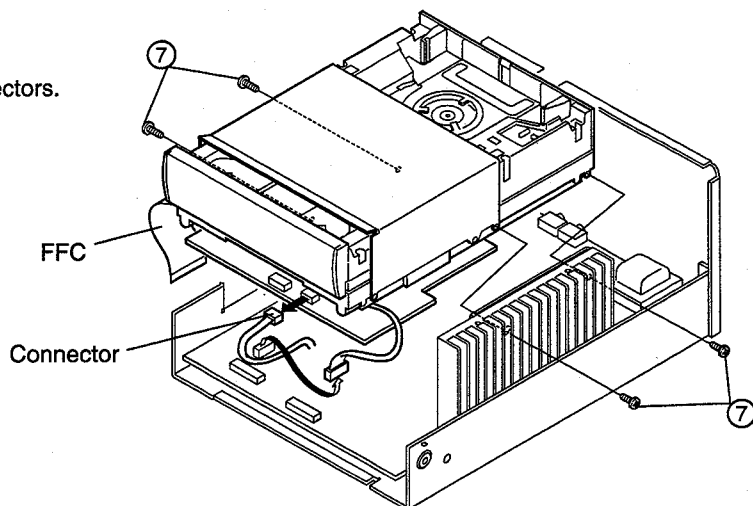

## CD P.W.B.

1. Remove 5 screws ⑧ on the back of the CD Mecha.
2. Disconnect 2 connectors.

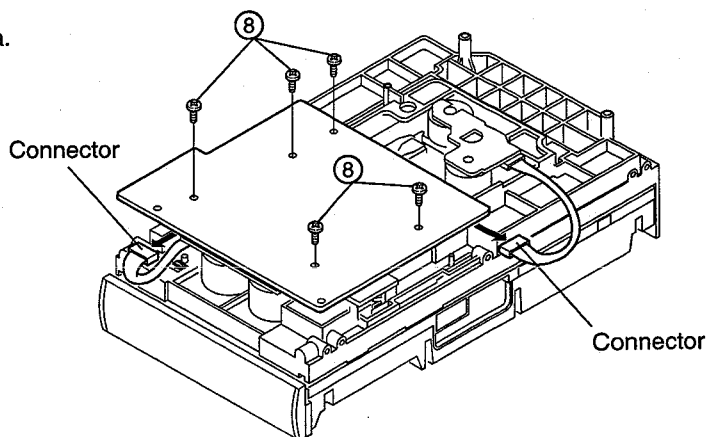

## Rear Panel

1. Remove 2 bottom screws ⑨ fixing the Rear Panel .
2. Remove 3 screws ⑩ on the rear.
3. Pull up the cord bush.
4. Disconnect 6 connectors coming from each P.W.B.

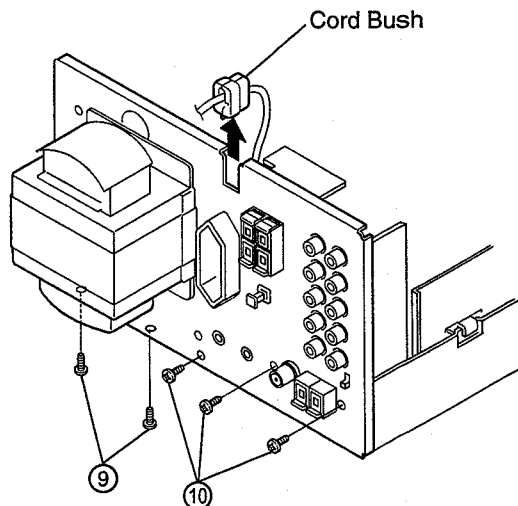

## Main P.W.B.

1. Remove 2 bottom screws ①① fixing the Heat Sink, and 2 bottom screws ①② fixing the Bracket.
2. Release PCB holder at the rear of the Main P.W.B.
3. Remove 4 screws ①③ fixing the Main P.W.B.

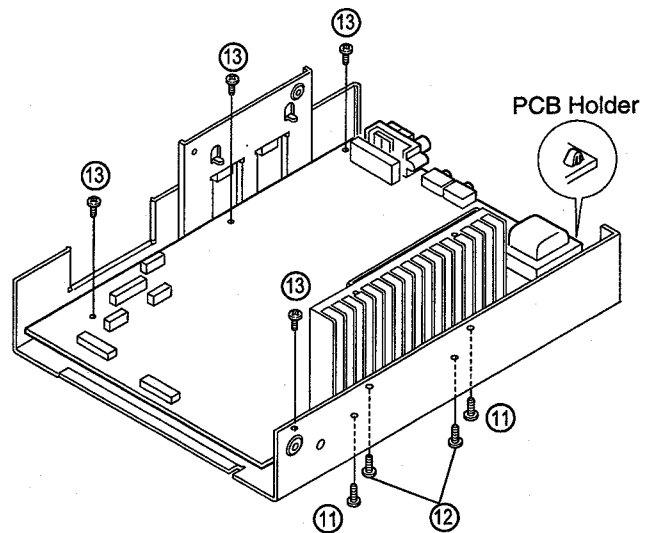

## Display P.W.B.

1. Pull out the Volume Knob.
2. Take off the plastic washer, nut and washer from the volume shaft.
3. Remove 10 screws ①④ fixing the Display P.W.B.

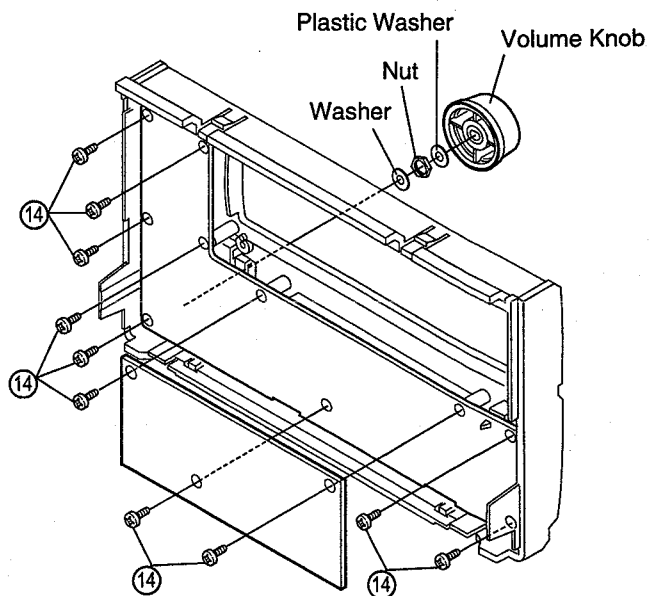

## DISASSEMBLING CD MECHA.

( Follow the procedure below in reverse order when reassembling )

### 1. Drawer

Push the Slider 2 Boss (white part) in the oval hole of the Back Chassis to the arrow direction with finger etc. When the Drawer comes out about 1cm, take it off in the order

① ~ ④ shown below.

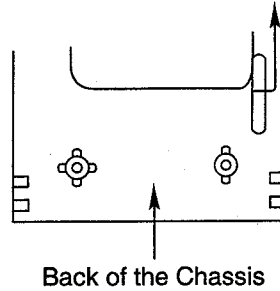

Do not pull the Card Wire strongly.  
Pay attention not to bend the root of the reinforce plate.

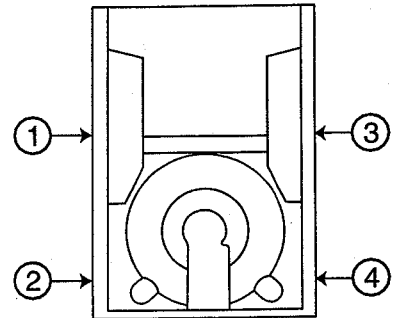

### 2. Carriage

- ① Turn the Bevel Gear to the arrow direction.
- ② Disengage it from the Carriage (No.1) in the arrow direction.

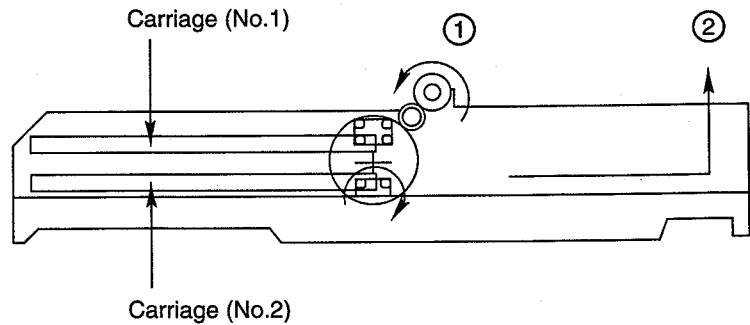

# ASSEMBLING CD MECHA.

## 1. Carriage Assembling

- ① Reassemble the Ass'y Bevel Gear if it's been taken off.

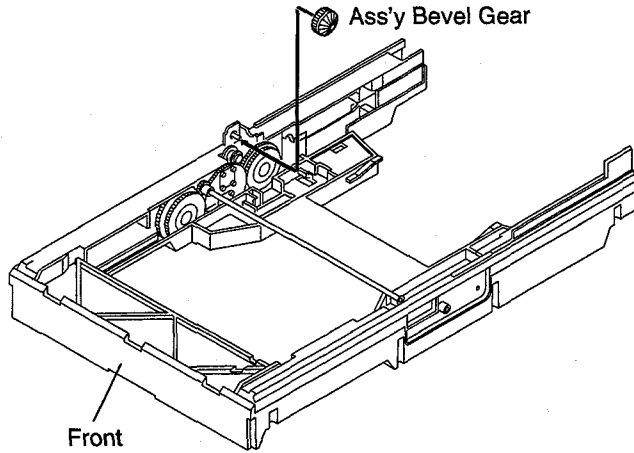

- ② While turning the Bevel Gear to the arrow direction continuously, count 5 turns starting from turning of the lower Pinion and stop the motion of the Bevel Gear when it halts rotation momentarily.

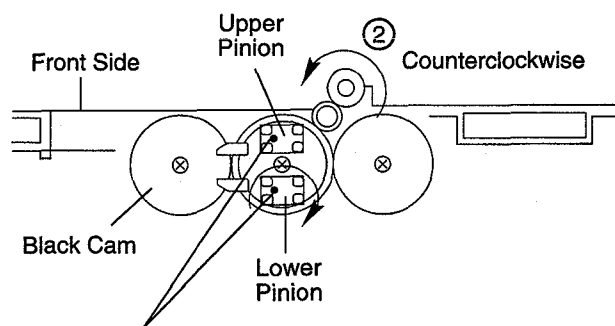

The ● mark of the Pinion, both upper and lower, should orient to the Black Cam (all process when inserting the carriage).

- ③ Put in line the lower end of the Carriage with the lower end of the right stopper.
- ④ Put the 1st tooth of the Carriage between pins of the lower Pinion.

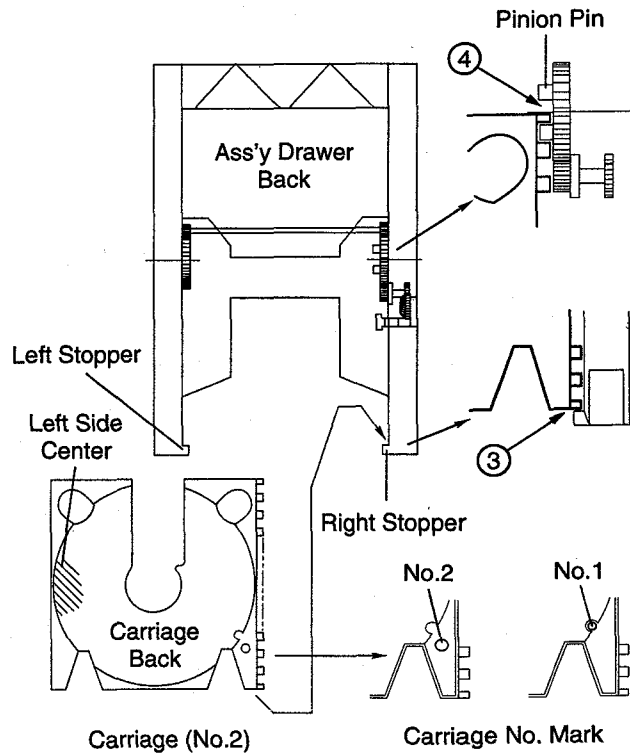

- ⑤ Insert with aligning the left lower end of the left stopper, then press down the left center of the carriage with finger to make it level.

Slant when assembling the process ③ and ④.

Keep the position where put in the process ③ and ④.

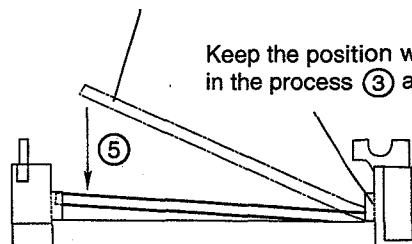

Ass'y Drawer viewed from the back side.

- ⑥ Rotate the lower Pinion 5 turns by turning the Bevel Gear in the arrow direction to complete forward transfer of the Carriage (No.2).

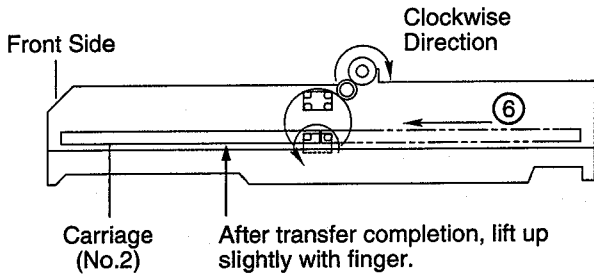

- ⑦ Turn the Bevel Gear to the arrow direction continuously, count 5 turns starting from turning of the upper Pinion and stop the motion of the Bevel Gear when it halts rotation momentarily.

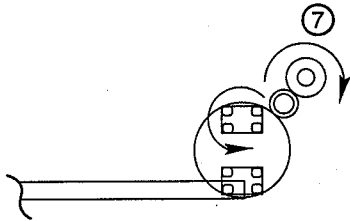

- ⑧ When still turning the Bevel Gear, the Carriage (No.2) which is applied force with finger moves to the Upper Pinion. (Stop just before the lower Pinion starts rotation, but keep applying force to lift up.)

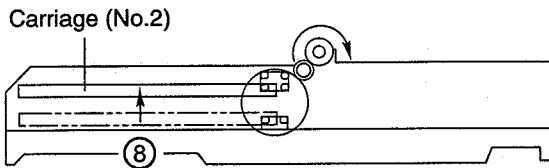

- ⑨ Carriage (No.1) insertion

With paying attention to the Carriage No. mark, do the same job as the process ③, ④ and ⑤.

- ⑩ Turn the Bevel Gear in the arrow direction to rotate the lower Pinion 5 turns and transfer the Carriage (No.1) forward.

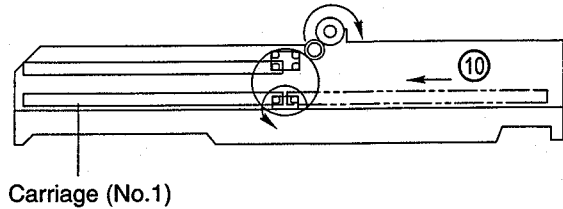

- ⑪ Put the left and right black mark within this range.

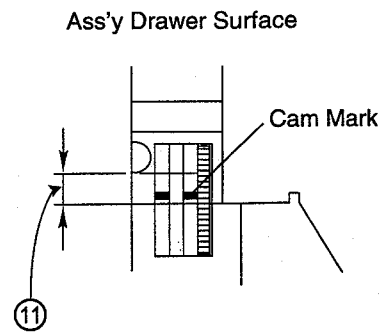



## 2. Ass'y Drawer Assembling

- ① Put ① part of the Drawer left side on the Chassis as shown with keeping about 10mm space.

Note: Be careful not to drop the Bevel Gear of the Drawer.

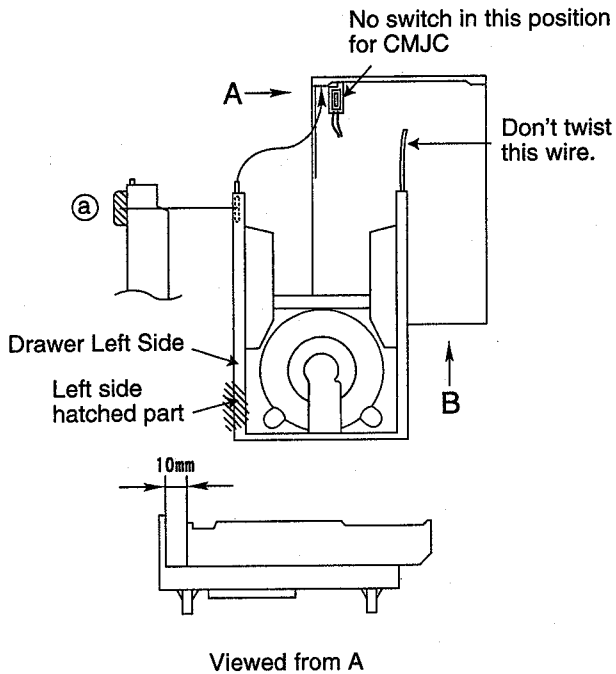

- ② Press the left hatched part of the Drawer lightly with finger to the arrow direction (to downward obliquely).
- ③ Lift up the right front of the Drawer in the condition that the left side hooks are hanged with each other.
- ④ There is a point where the Drawer shifts left with click (check with left finger).
- ⑤ Lower the right side slowly from this angle with adding about 5mm front and back motion as shown in fig. below.

Note: Be careful not to apply force to the gear more than necessary.

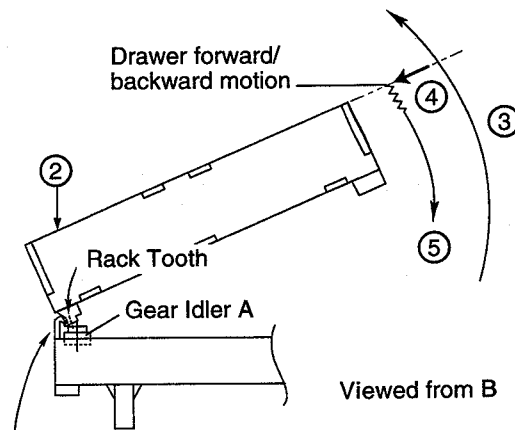

Hold with the index finger lightly so that the Chassis hook and Drawer hook are not detached.

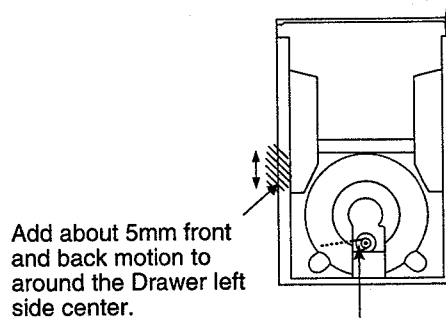

The belt moves according to the Drawer's front and back motion if the Rack tooth and Gear idler A are meshed. Repeat the steps ②-⑤ if not move.

- ⑥ Hold the Bevel Gear with fingers through the space between the Drawer right and Chassis, then slide to the position in the middle of the Carriage and Pulley C.
- ⑦ With keeping the angle above mentioned, move the Drawer to align the Drawer's bearing and Bevel Gear's concave part with pressing the center of the Clamper.
- ⑧ After confirming that the Drawer's bearing and Bevel Gear are aligned properly, insert into the Chassis hooks in the order ⑧⑨.

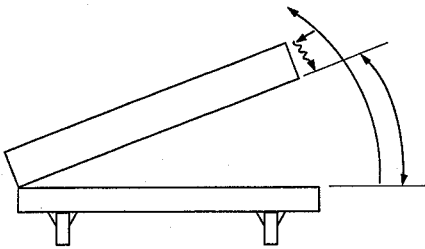

Lower the Drawer right side until the angle to which two fingers are accessible and the Bevel Gear is able to slide. (Make the gears to be meshed.)

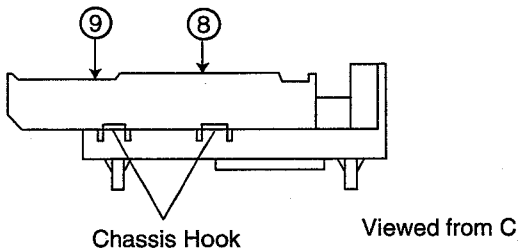
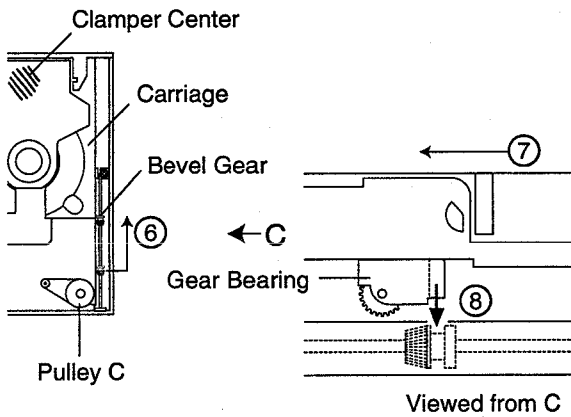

- ⑩ Manually open the Drawer completely, and check that all the Chassis hooks are hanged on the Drawer. Open rather quickly, and stop at end so that the Slider 2 returns back by inertia to push the Slider 1 and to lower the Clamper.

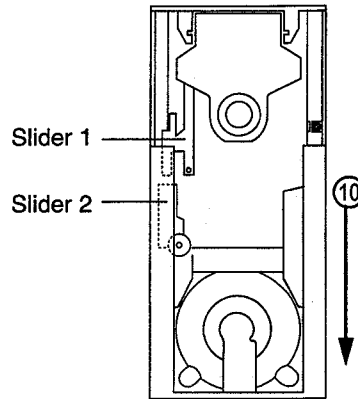

- ⑪ Push in the Drawer left side to the close end with hand slowly. Push in until the Chassis is bent, then pull the Drawer with finger to check that it is locked.

BLOCK DIAGRAM

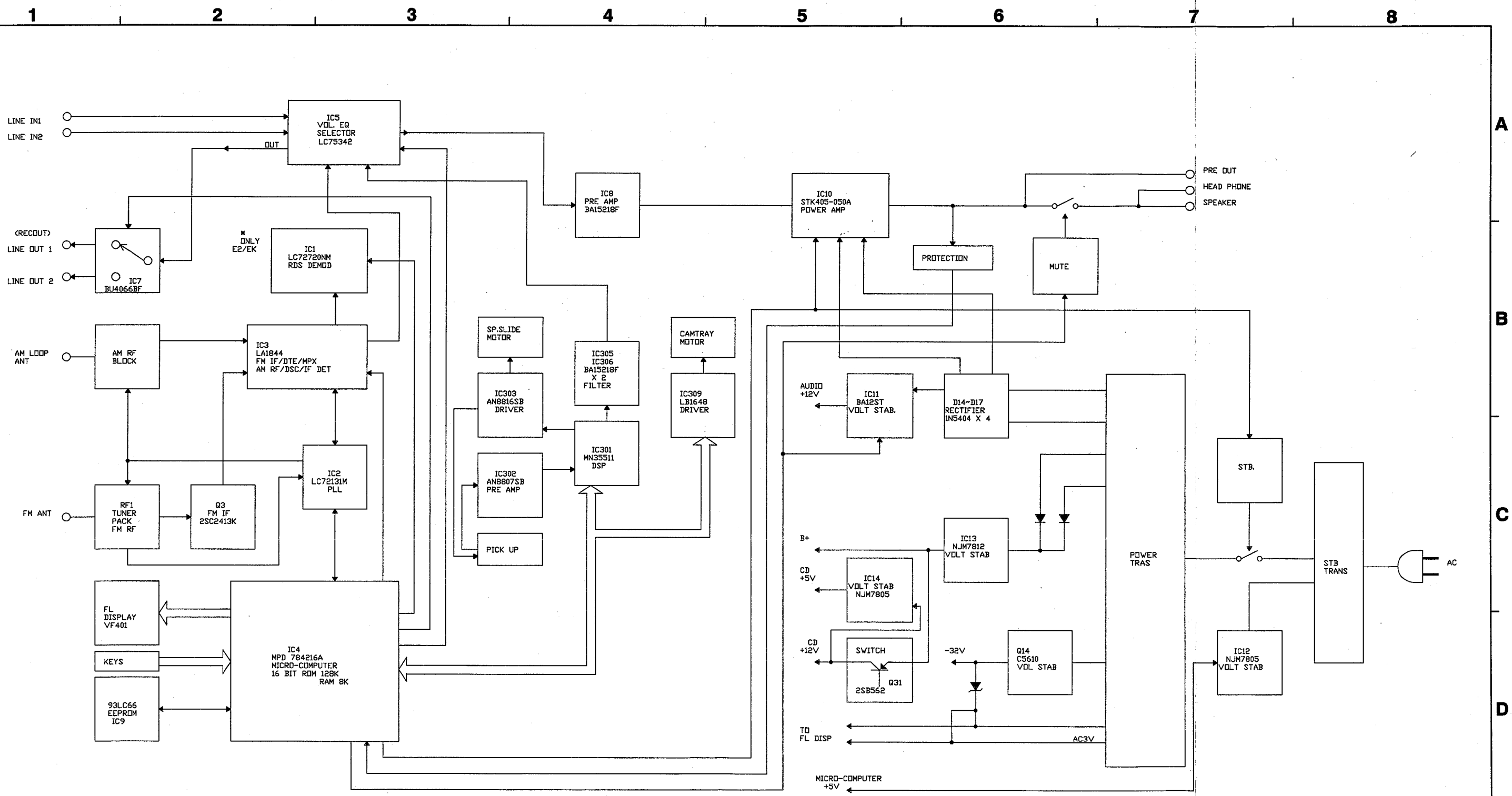

A

B

C

D

E

## ADJUSTMENT

### • Confirming the Servo

A microcomputer adopted in this unit has the service programs so that each servo adjustment can be performed easily by the operating buttons.

This unit which adopted digital servo has the ability to automatically adjust Focus Gain, Focus Balance, Focus Offset, Tracking Gain, Tracking Balance, and Tracking Offset.

### 1. Actuating the Service Program

Plug the AC cord while pressing the Power and Function keys.

(Service program actuates and displays track number 01.)

**Note:** The operating button do not function when service program actuates.

### 2. Operating Function at Service Program Actuation

Button Operation	Function	Description																					
OPEN/CLOSE ▲	Opens or closes the disc holder.	<ul style="list-style-type: none"> <li>• Opens or closes when disc is stopped.</li> <li>• Operates other keys after open or close.</li> </ul>																					
STOP ■	Stops system operation.	<ul style="list-style-type: none"> <li>• Displays track number 01.</li> <li>• Press when adjustment completed or correcting it.</li> </ul>																					
PLAY ▶	Operates the Focus servo and turns disc.	<ul style="list-style-type: none"> <li>• Displays track number 02 when operation is completed.</li> </ul>																					
◀◀	Performs Focus servo, Tracking servo, Slide servo, Spindle servo and various automatically adjustment.	<ul style="list-style-type: none"> <li>• Performs Tracking servo and Slide servo when pressing PLAY button.</li> <li>• Displays track number 03 when operation is completed.</li> <li>• When unusualness is existed, displays index number (error message). But E9, E - not error message.</li> </ul>																					
▶▶	Displays automatically adjustment effect of FG, FEXP, FBAL, FOFS, TG, TEXP, TBAL and TOFS.	<ul style="list-style-type: none"> <li>• Press ■ button when ◀◀ button operation is completed.</li> <li>• When pressing ▶▶ button every once, displays automatically adjusting value about FG, FBAL, FOFS, TG, TBAL, and TOFS in the sequence.</li> <li>• Displays following indication:</li> </ul> <table border="1" style="margin-left: 40px;"> <thead> <tr> <th></th> <th>INDEX</th> <th>TIME</th> </tr> </thead> <tbody> <tr> <td>FG</td> <td>01</td> <td>XXmXXs</td> </tr> <tr> <td>FBAL</td> <td>02</td> <td>XXmXXs</td> </tr> <tr> <td>FOFS</td> <td>03</td> <td>XXmXXs</td> </tr> <tr> <td>TG</td> <td>04</td> <td>XXmXXs</td> </tr> <tr> <td>TBAL</td> <td>05</td> <td>XXmXXs</td> </tr> <tr> <td>TOFS</td> <td>06</td> <td>XXmXXs</td> </tr> </tbody> </table>		INDEX	TIME	FG	01	XXmXXs	FBAL	02	XXmXXs	FOFS	03	XXmXXs	TG	04	XXmXXs	TBAL	05	XXmXXs	TOFS	06	XXmXXs
	INDEX	TIME																					
FG	01	XXmXXs																					
FBAL	02	XXmXXs																					
FOFS	03	XXmXXs																					
TG	04	XXmXXs																					
TBAL	05	XXmXXs																					
TOFS	06	XXmXXs																					
Other Buttons	No normal operation.	<ul style="list-style-type: none"> <li>• Do not operate other button except above.</li> <li>• When an error occurs, immediately turn power switch OFF.</li> </ul>																					

**Note:** Do not use remote control during service program operation.

### 3. Confirming Method

- (1) Required Measuring Equipments for adjustment
  1. Dual-trace oscilloscope
  2. Adjustment disc TCD-784 (ABEX)
- (2) Adjustment location

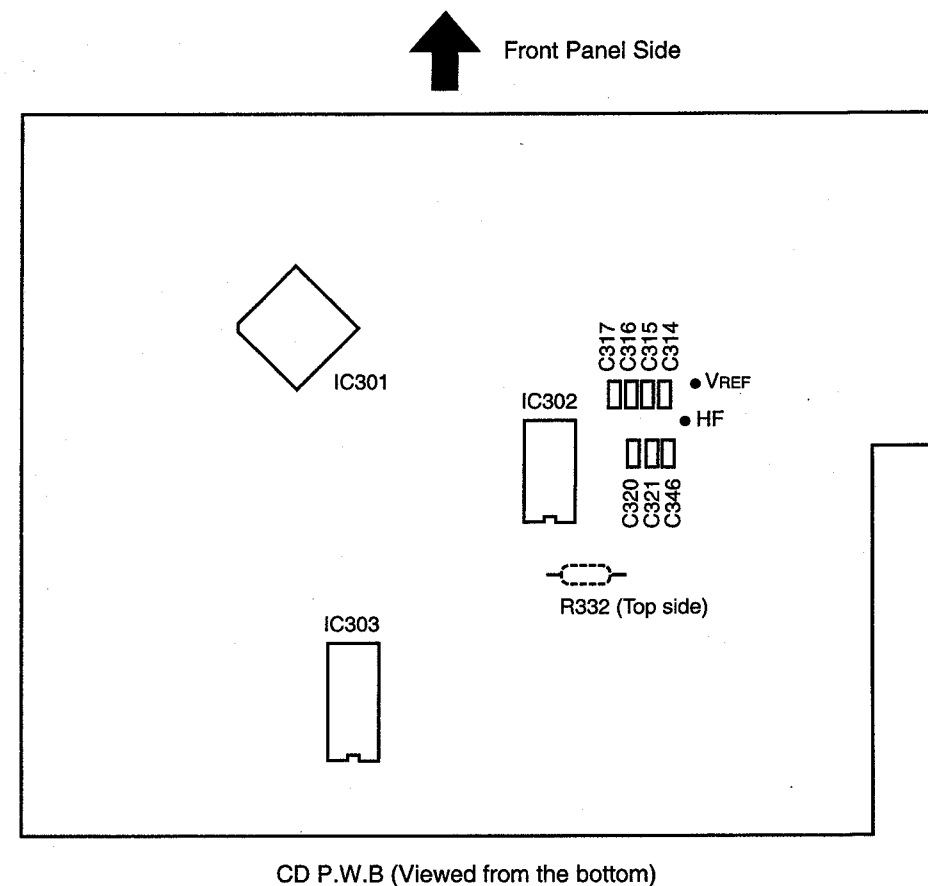

#### (3) Confirming procedure

1. Actuate service program.
2. Load adjustment disc TCD-784.
3. Press ▶ to indicate track number 02.
4. Press ◀◀ to indicate track number 03.
5. Press ■ button.
6. When pressing ▶▶ button every once, confirm automatically adjusting values about FG, FBAL, FOFS, TG, TBAL and TOFS (refer to table 1 for the limits of value).
7. When service program is completed, return to normal mode (turn power switch ON).
8. Confirm HF level.

#### (4) Pickup current measurement

1. Press ▶ to indicate track number 02.
2. Press ◀◀ to indicate track number 03.
3. Measure the voltage between both leads of Resistor R332, and confirm that the value is 1.4 V or less (normally 0.9 V or around).

(5) Confirm automatically adjustment values about FG, FBAL, FOFS, TG, TBAL and TOFS.

1. Press ► button, displays track number 02.
2. Press ◀◀ button, displays track number 03.
3. Press ■ button, displays track number 01.
4. Press ►►► button, displays FG (Focus Gain Tentative) value, confirm the value within the limits of table 1.
5. Press ►►► button, displays FBAL (Focus balance) value, confirm the value within the limits of table 1.
6. Press ►►► button, displays FOFS (Focus offset) value, confirm the value within the limits of table 1.
7. Press ►►► button, displays TG (Tracking Gain) value, confirm the value within the limits of table 1.
8. Press ►►► button, displays TBAL (Tracking Balance) value, confirm the value within the limits of table 1.
9. Press ►►► button, displays TOFS (Tracking Offset) value, confirm the value within the limits of table 1.

**Confirming Table about Digital Servo Adjusting Value (table 1)**

	TRACK INDEX	XXMXXS
FG	01 <u>1</u>	M42S~1M00S
FBAL	01 <u>2</u>	-1M25S~1M25S
FOFS	01 <u>3</u>	-M35S~M35S
TG	01 <u>4</u>	M51S~1M56S
TBAL	01 <u>5</u>	-58S~1M04S
TOFS	01 <u>6</u>	-M15S~M15S

(6) HF level Confirming

Connection						
Oscilloscope	Check	Step				
<table border="1" style="width: 100%; border-collapse: collapse;"> <tr> <th style="width: 50%;">V</th> <th style="width: 50%;">H</th> </tr> <tr> <td>50mV/div or 20mV/div</td> <td>0.2μs/div or 0.5μs/div</td> </tr> </table> <ul style="list-style-type: none"> <li>• Set input mode to ALTERNATE or CHOPPER.</li> </ul>	V	H	50mV/div or 20mV/div	0.2μs/div or 0.5μs/div	<p style="text-align: center;">A=0.40~0.85V</p> <p style="text-align: center;">Eye Pattern</p>	<ol style="list-style-type: none"> <li>1. Press ► button.</li> <li>2. Check HF level with oscilloscope.</li> <li>3. Confirm that the waveform is in good shape. (◊ eye pattern in center must be able to discriminate clearly.)</li> </ol>
V	H					
50mV/div or 20mV/div	0.2μs/div or 0.5μs/div					

## SEMICONDUCTORS

## IC's

## μPD784216AGC-112-8EU (IC4)

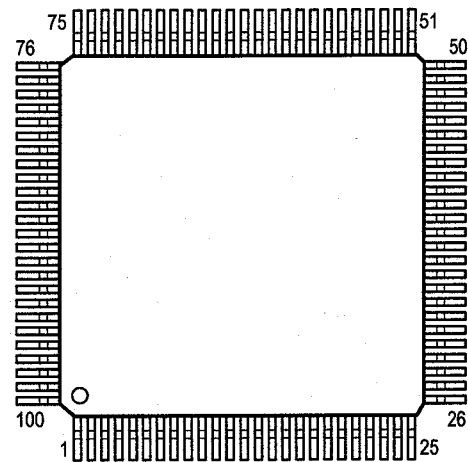

## μPD784216AGC-112-8EU Terminal Function

Pin. No.	Name	Symbol	I/O	Function
1	P120/RTP0	ENC A	I	Rotary encoder INPUT A
2	P121/RTP1	ENC B	I	Rotary encoder INPUT B
3	P122/RTP2	V.MUTE	O	Volume mute output, mute: Low
4	P123/RTP3	/POWER	O	Amp circuit power ON/OFF output, ON: High
5	P124/RTP4	/RMUTE	O	Speaker Relay ON/OFF output, ON: High
6	P125/RTP5	N.C	O	
7	P126/RTP6	SEL. EEPROM	O	EEPROM chip enable output
8	P127/RTP7	FLOE	O	Chip select output to FL tube controller
9	VDD	VDD	—	Positive power: +5V
10	X2	X2	—	X'tal connection for main clock oscillation
11	X1	X1	I	X'tal connection for main clock oscillation
12	Vss	Vss	—	GND potential
13	XT2	XT2	—	X'tal connection for main sub-clock oscillation, not used
14	XT1	XT1	I	X'tal connection for main sub-clock oscillation, not used: Connect to Vss or Vcc
15	/RESET	/RESET	I	Micro-computer reset input
16	P00/INTP0	REMOCON	I	Remote-control receive data input
17	P01/INTP1	50/60	I	50/60Hz AC input
18	P02/INTP2/NMI	/DB RXD	I	DENON BUS Data input (interrupt input)
19	P03/INTP3	PROTECT	I	Speaker Terminal DC voltage detect signal input L: protect
20	P04/INTP4	N.C	O	
21	P05/INTP5	BLKCK	I	Subcode bitclock input
22	P06/INTP6	/INT	I	VCD Interrupt request
23	AVDD	AVDD	—	A/D converter analog power: +5V
24	AVref0	AVref0	—	A/D converter reference voltage input: 5V
25	P10/ANI0	KEY1	I	Unit operation button input1
26	P11/ANI1	KEY2	I	Unit operation button input2
27	P12/ANI2	KEY3	I	Not used: Connect to GND
28	P13/ANI3	KEY4	I	Not used: Connect to GND
29	P14/ANI4	TLOCK	I	CD-DSP TLOCK input H: LOCK
30	P15/ANI5	FLOCK	I	CD-DSP FLOCK input H: LOCK
31	P16/ANI6	SENCE	I	CD-DSP SENCE input
32	P17/ANI7	STAT	I	CD Status signal
33	AVss	AVss	—	A/D, D/A converter GND position
34	P130/ANO0	LINE1	O	LINE OUT Control signal output1
35	P131/ANO1	LINE2	O	LINE OUT Control signal output2

Pin. No.	Name	Symbol	I/O	Function
36	AVref1	AVref1	—	D/A converter reference voltage input
37	P70/RxD2/SI2	CDFL DATAI	I	cd-dsp/FL Data input
38	P71/TxD2/SO2	CDFL DATAO	O	cd-dsp/FL Data output
39	P72/ASCK2/SCK2	CDFL CLK	O	cd-dsp/FL Data CLOCK output
40	P20/RxD1/SI1	DATA RXD	I	DATA BUS (for VOL, PLL, RDS IC) Data input
41	P21/TxD1/SO1	DATA TXD	O	DATA BUS (for VOL, PLL, RDS IC) Data output
42	P22/ACSK1/SCK1	DATA CLK	O	DATA BUS (for VOL, PLL, RDS IC) Clock output
43	P23/PCL	DATA CE	O	DATA BUS (for VOL, PLL, RDS IC) Chip enable output
44	P24/BUZ	/RDSRST	O	RDS IC reset output
45	P25/SI0/SDA0	DB RXD	O	DENON BUS DATA INPUT
46	P26/SO0	DB TXD	I	DENON BUS DATA OUTPUT
47	P27/SCK0/SCL0	DB CLK	O	DENON BUS CLOCK OUTPUT
48	P80/A0	/SD	I	FM/AM Tuning signal input, Tuned: Low
49	P81/A1	/ST INC	I	FM stereo demodulation detect input, Stereo: Low
50	P82/A2	/TMUTE	O	Tuner mute output, mute: Low
51	P83/A3	SUCS	O	Subcode SELECT H: CD SUBQ CLOCK
52	P84/A4	USA	I	Initial setting input
53	P85/A5	EURO	I	Initial setting input
54	P86/A6	FREQ	I	Initial setting input
55	P87/A7	RDS	I	Initial setting input
56	P40/AD0	LED3G	O	Disc3 Green LED output, Light: High
57	P41/AD1	LED3R	O	Disc3 Red LED output, Light: High
58	P42/AD2	LED2G	O	Disc2 Green LED output, Light: High
59	P43/AD3	LED2R	O	Disc2 Red LED output, Light: High
60	P44/AD4	LED1G	O	Disc1 Green LED output, Light: High
61	P45/AD5	LED1R	O	Disc1 Red LED output, Light: High
62	P46/AD6	LED POWER G	O	POWER/STANDBY Green LED output, Light: High
63	P47/AD7	LED POWER R	O	POWER/STANDBY Red LED output, Light: High
64	P50/A8	EX SW	I	Changer mecha, Carriage Extra position: SW2 (X3)/not used: connect to ext. pulldown (X1)
65	P51/A9	HOME SW	I	Changer mecha, Carriage Home position: SW3 (X3)/not used: connect to ext. Pulldown (X1)
66	P52/A10	D2 SW	I	Changer mecha, Carriage number, SW5 (X3)/CD mecha. Closed SDW (X1)
67	P53/A11	D1 SW	I	Changer mecha, Carriage number, SW4 (X3)/CD mecha Open SW. (X1)
68	P54/A12	O/C SW	I	Changer mecha, Open/Close detect: SW6 (X3)/not used: connect to ext. pulldown (X1)
69	P55/A13	FWD SW	I	Changer mecha. slider Forward position: SW7 (X3)/not used: connect to ext. Pulldown (X1)
70	P56/A14	RVS SW	I	Changer mecha. Slider Reverse position: SW8 (X3)/not used: connect to ext. Pulldown (X1)
71	P57/A15		O	Not used: NC
72	Vss	Vss	—	GND potential
73	P60/A16	FL BLK	O	Putting out light of FL display H: lighting
74	P61/A17	N.C	O	
75	P62/A18	N.C	O	
76	P63/A19	N.C	O	
77	P64/RD	SRST	O	CD-DSP reset output, output, reset: High
78	P65/WR	VRST	O	VCD module output, reset: High
79	P66/WAIT	N.C	O	
80	P67/ASTB	N.C	O	
81	VDD	VDD	—	Positive power
82	P100/TI5/TO5	DRAWER-	O	Changer mecha. Drawer motor- (X3)/CD mecha. Open
83	P101/TI6/TO6	DRAWER+	O	Changer mecha. Drawer motor+ (X3)/CD mecha. Close
84	P102/TI7/TO7	CARRIGE-	O	Changer mecha. Carriage motor- (X3)/not used: NC (X1)
85	P103/TI8/TO8	CARRIGE+	O	Changer mecha, Carriage motor+ (X3)/not used: NC (X1)
86	P30/TO0	MLD	O	CD-DSP serial communication load output
87	P31/TO1	N.C	O	Not used: NC
88	P32/TO2	DMUTE	O	CD-DSP DMUTE, mute: High
89	P33/TI1	NTSC/PAL	I	NTSC/PAL switching input, NTSC: Low
90	P34/TI2	CDPOWER	O	CD power control signal output H: POWER ON
91	P35/TO0	CHA/SIG	I	3CD Changer/Single CD switching input, 3CD: High
92	P36/TO2		O	Not used: NC
93	P37	HPSW	I	HEADPHONE Insert switch detect signal input
94	TEST/VPP	TEST	I	not used: Connect to GND
95	P90	CD/VCD	I	CD/VCD switching input, CD: High
96	P91	INSW	I	Pickup inner-most detect input, inner most: Low at on
97	P92	VCL	O	VCD module clock output, CD: ext. Pullup
98	P93	VDI	I	VCD module data input, CD: ext. pullup
99	P94	VDO	O	VCD module data output
100	P95	VCE	O	VCD module serial communication select output

**MN35511 (IC301)**

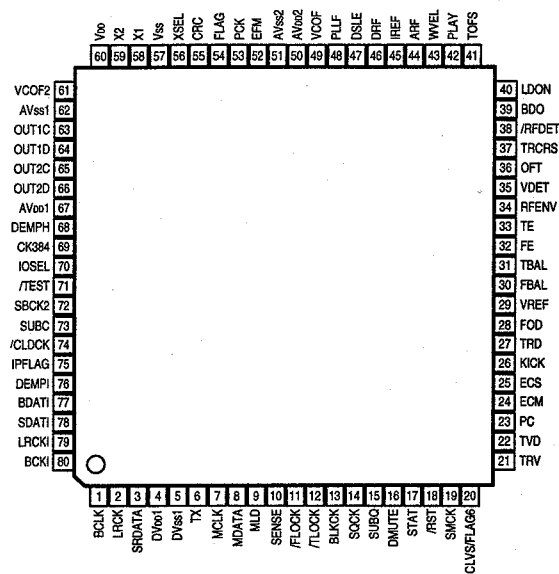

**AN8816SB (IC303)**

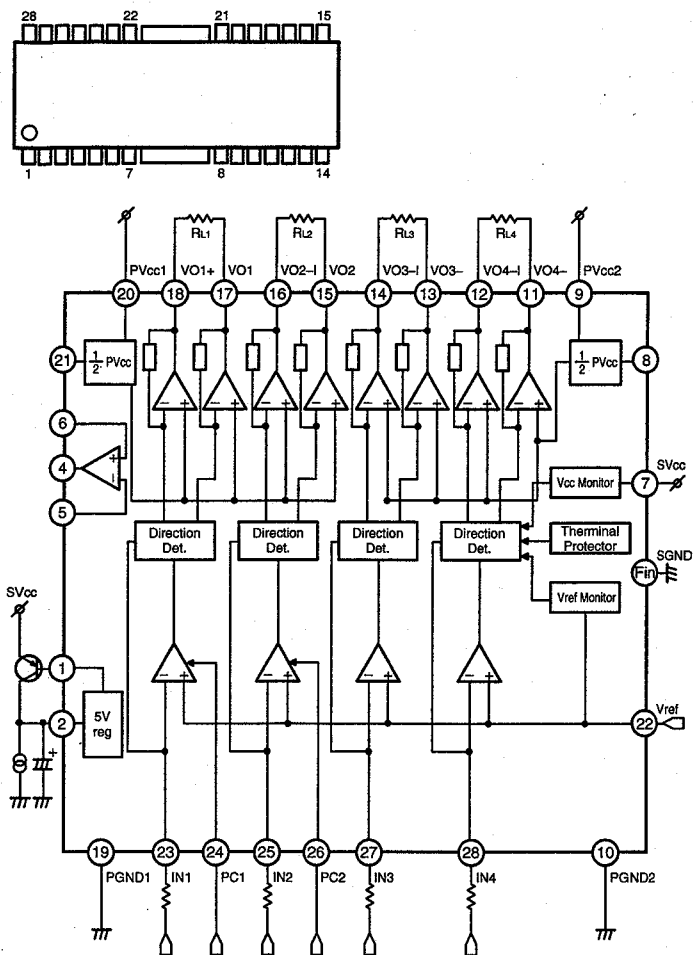

**BA15218F (IC6, 8, 305, 306)**

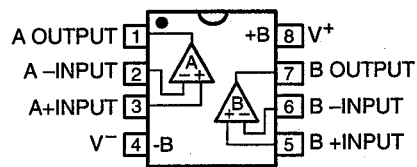

**NJM7805FA (IC12, 14)  
NJM7812FA (IC13)**

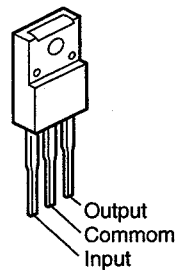

**AN8807SB (IC302)**

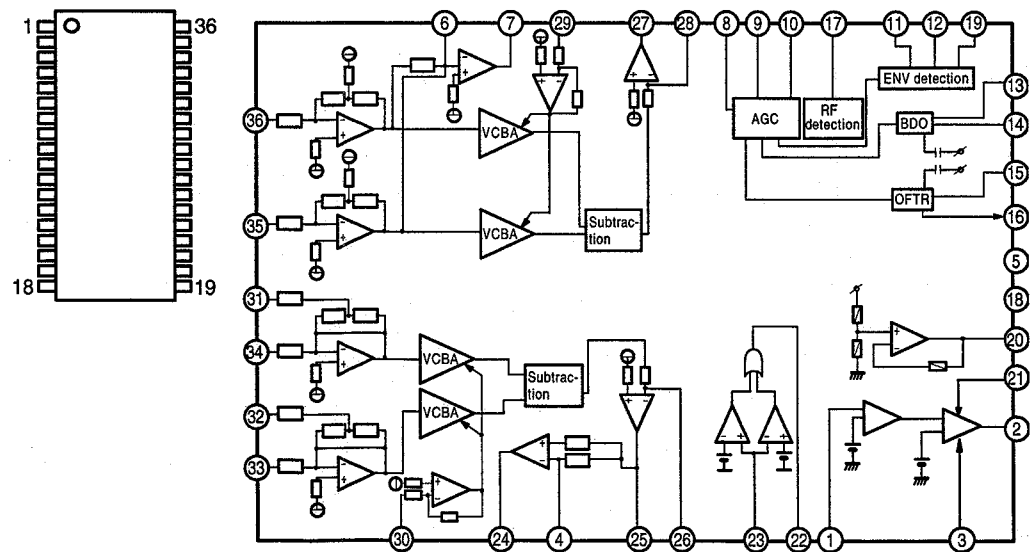

**LC75725E (IC401)**

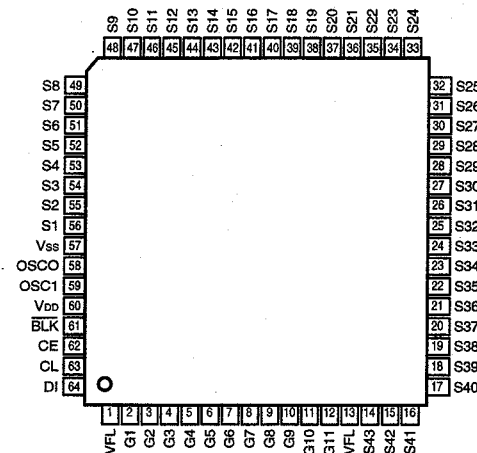

**Terminal Function**

Pin No.	I/O	Name	Function
1, 13	—	VFL	Power supply pin to driver block
2~12	O	G1~G11	Digit output pin
14~56	O	S1~S43	Segment output pin
57	—	Vss	Power supply pin
58	O	OSCO	Pin for oscillator
59	I	OSCI	Pin for oscillator
60	—	VDD	Power supply pin to logic block
61	I	BLK	Display off input pin
62	I	CE	Input for serial data transfer
63	I	CL	CE: Chip enable CL: Sync clock
64	I	DI	DI: Transfer data

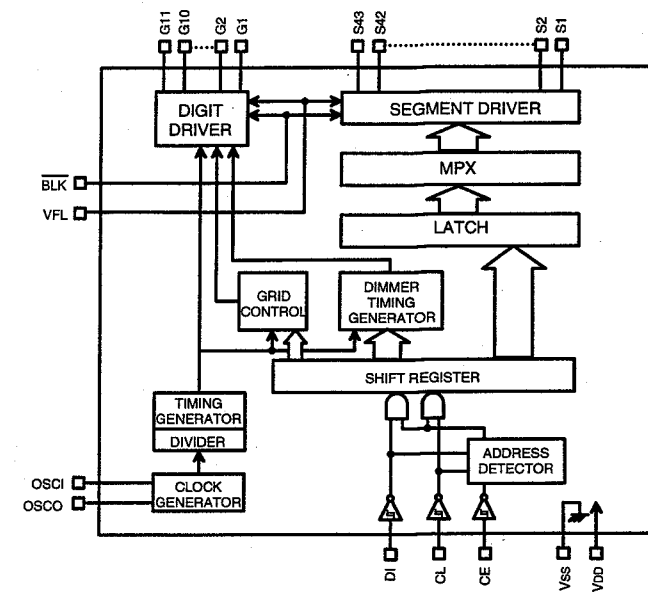

**BU4066BCF (IC7)**

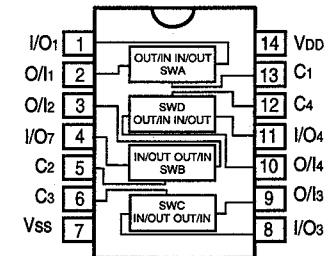

**LC75342M (IC5)**

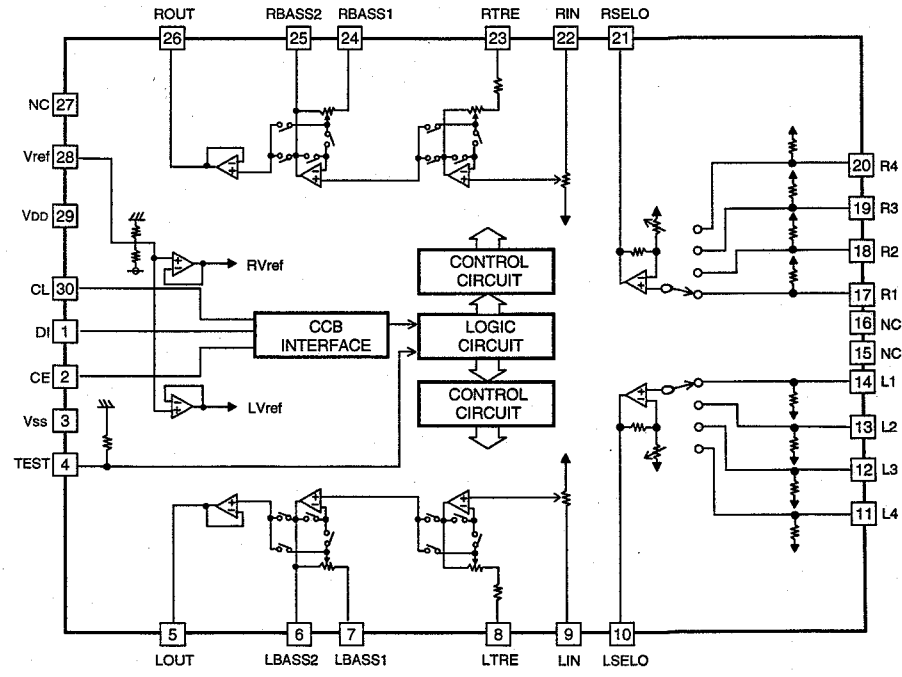
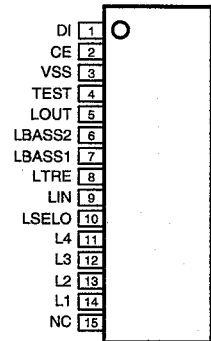

LC72720M (IC1)

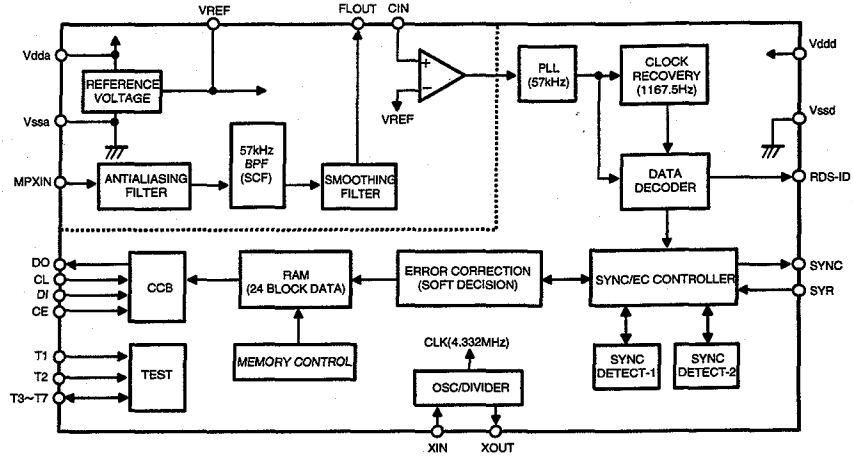
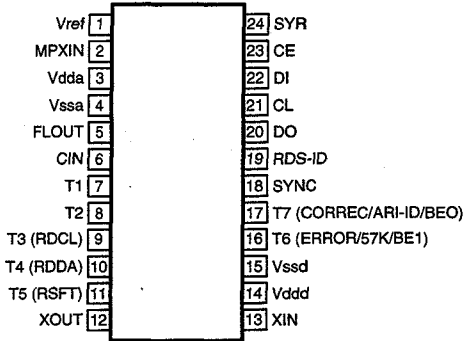

LA1844 (IC3)

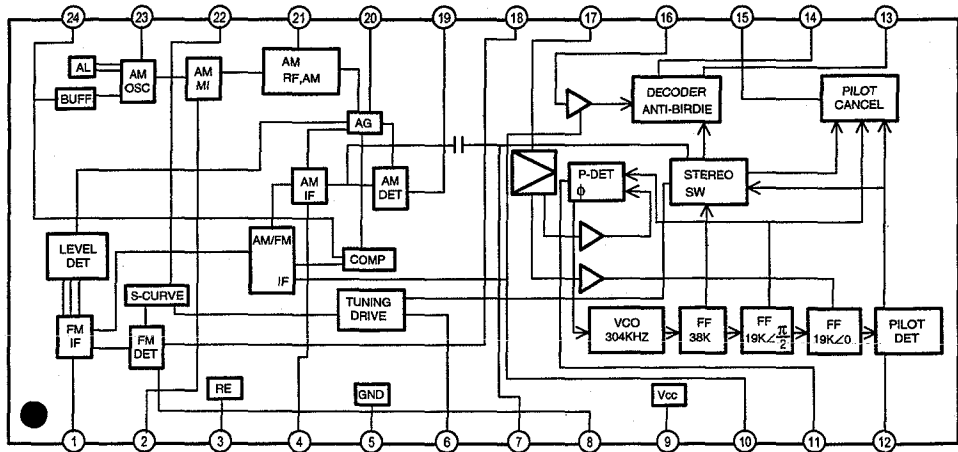

STK405-050A (IC10)

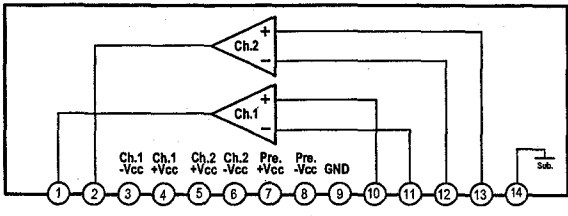
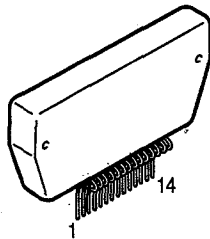

93LC66 (IC9)

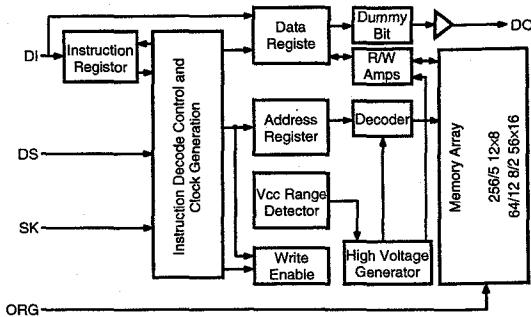
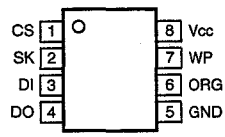



LC72131M (IC2)

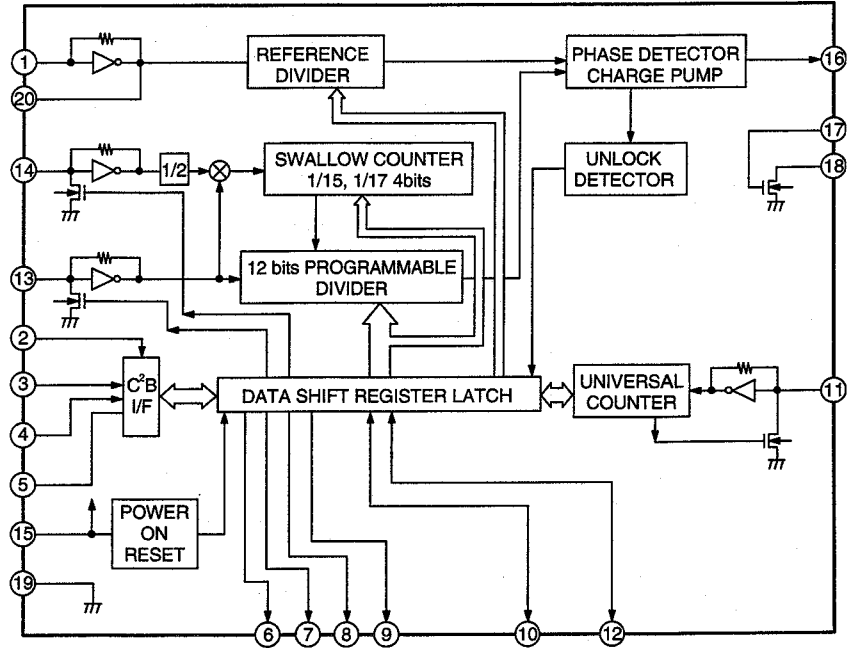
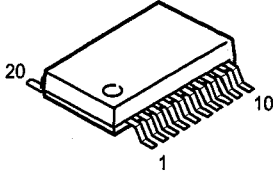

BA12ST (IC11)



- 1: CTL
- 2: Vcc
- 3: GND
- 4: OUT
- 5: N.C.

MN1280Q (IC15)

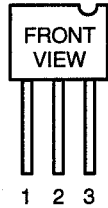

- 1: Output
- 2: Input
- 3: GND

LB1648 (IC309)

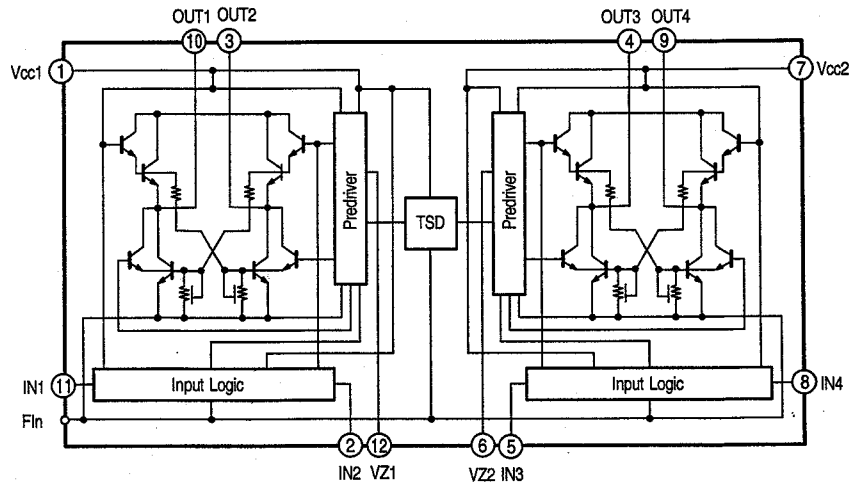
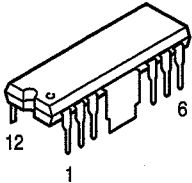



PRINTED WIRING BOARDS

1 2 3 4 5 6 7 8

MAIN P.W.B. UNIT ASS'Y

A

B

C

D

E

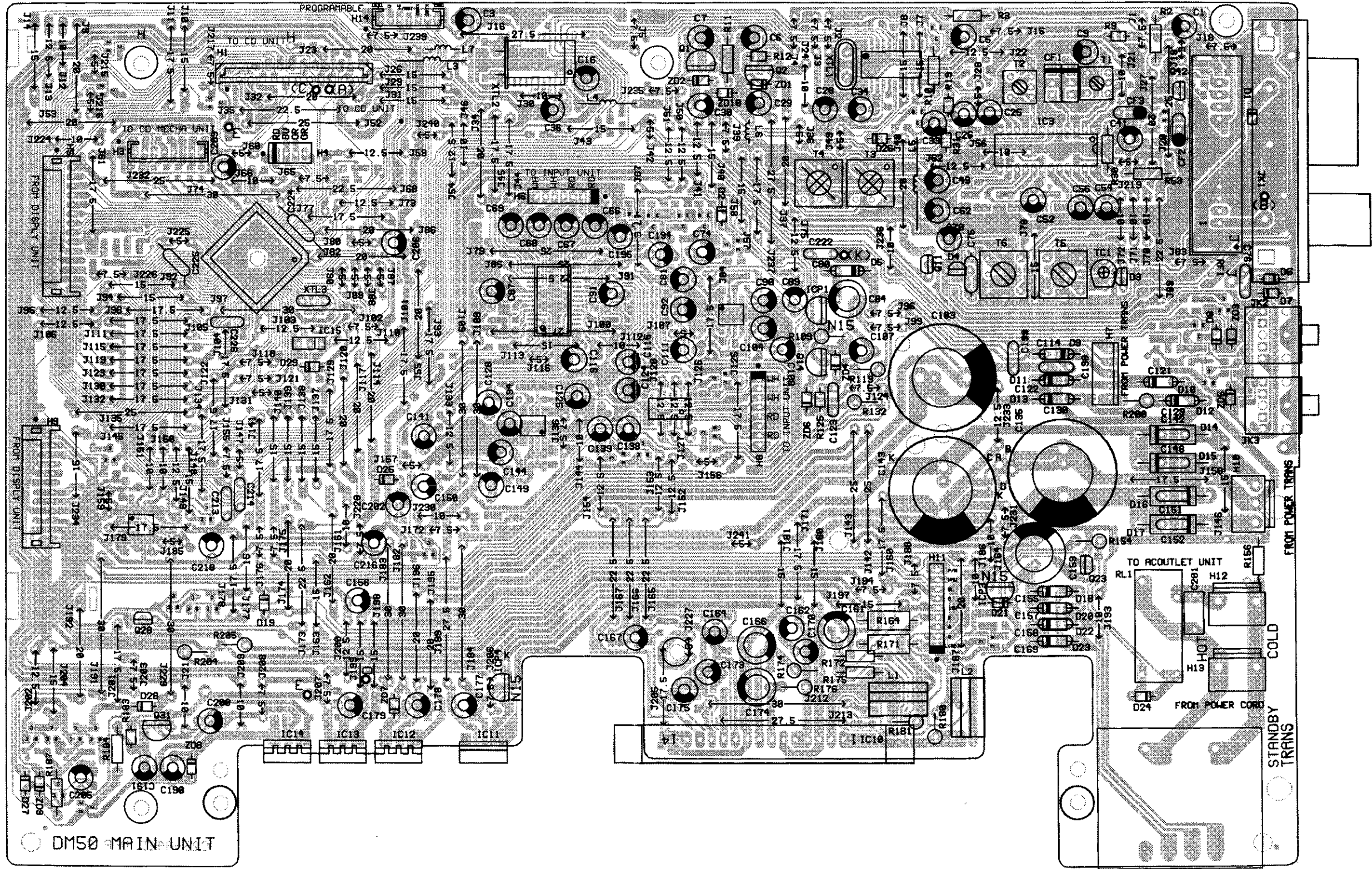

COMPONENT SIDE

1 2 3 4 5 6 7 8

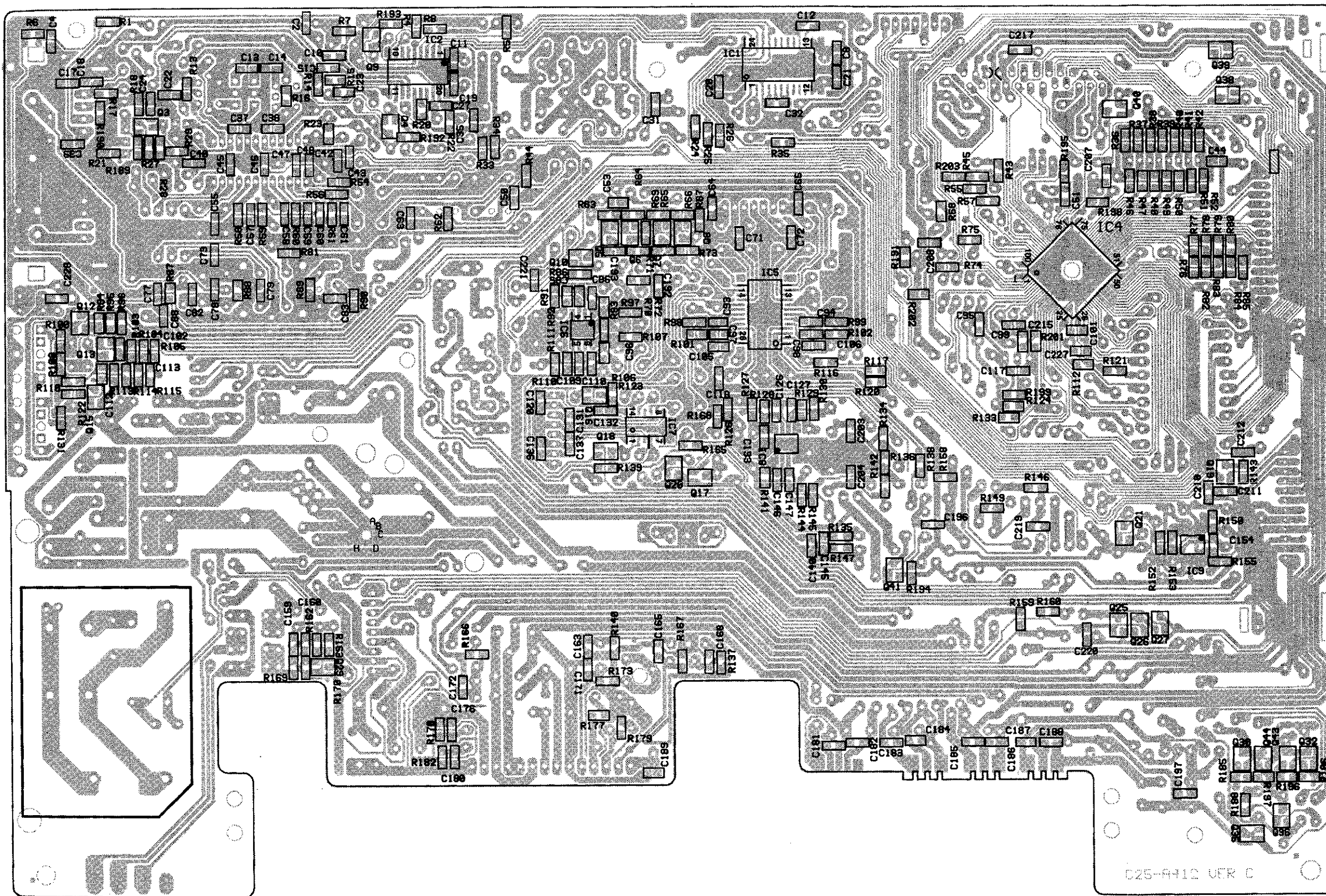

A  
B  
C  
D  
E

FOIL SIDE

D25-A412 UFR C

1 2 3 4 5 6 7 8

DISPLAY P.W.B. ASS'Y

A  
B  
C  
D  
E

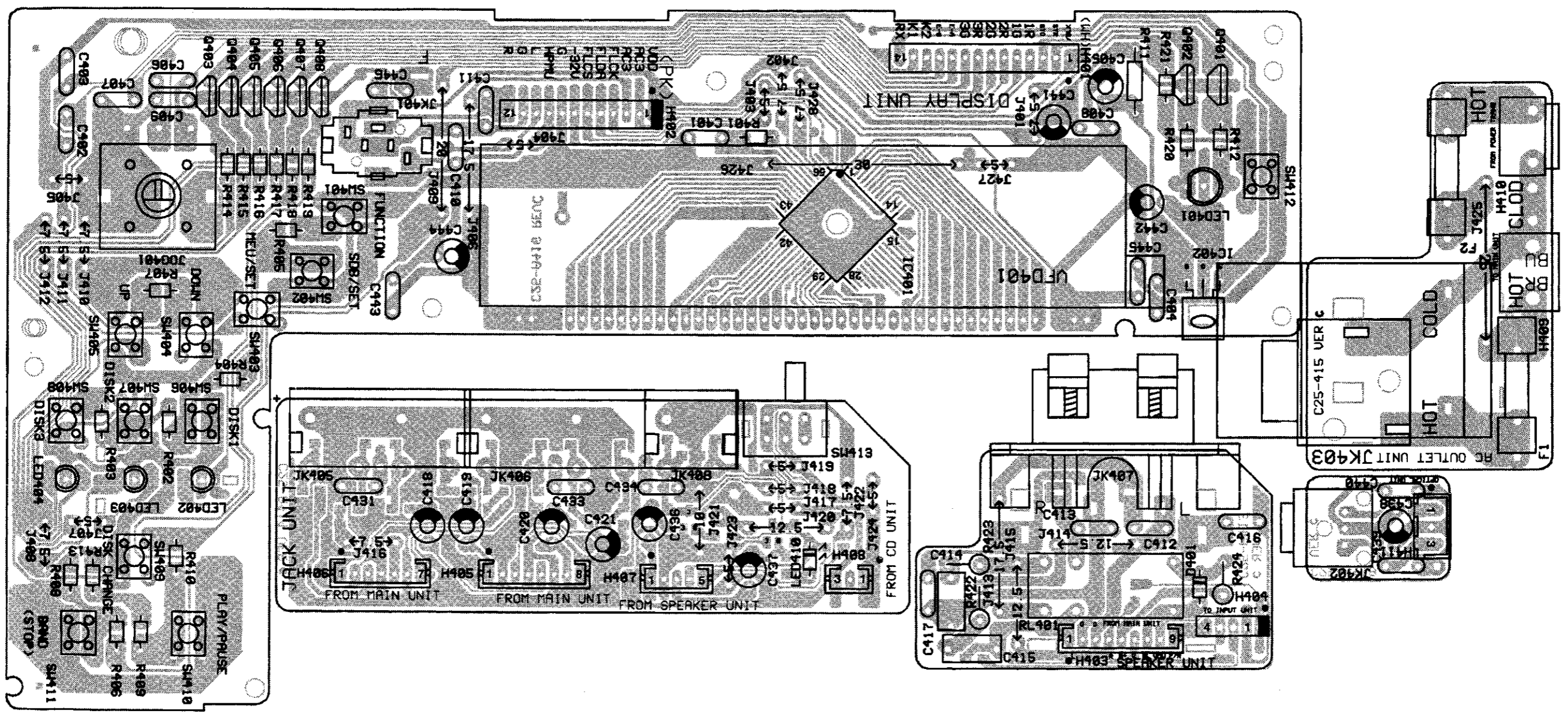

COMPONENT SIDE

1 2 3 4 5 6 7 8

A  
B  
C  
D  
E

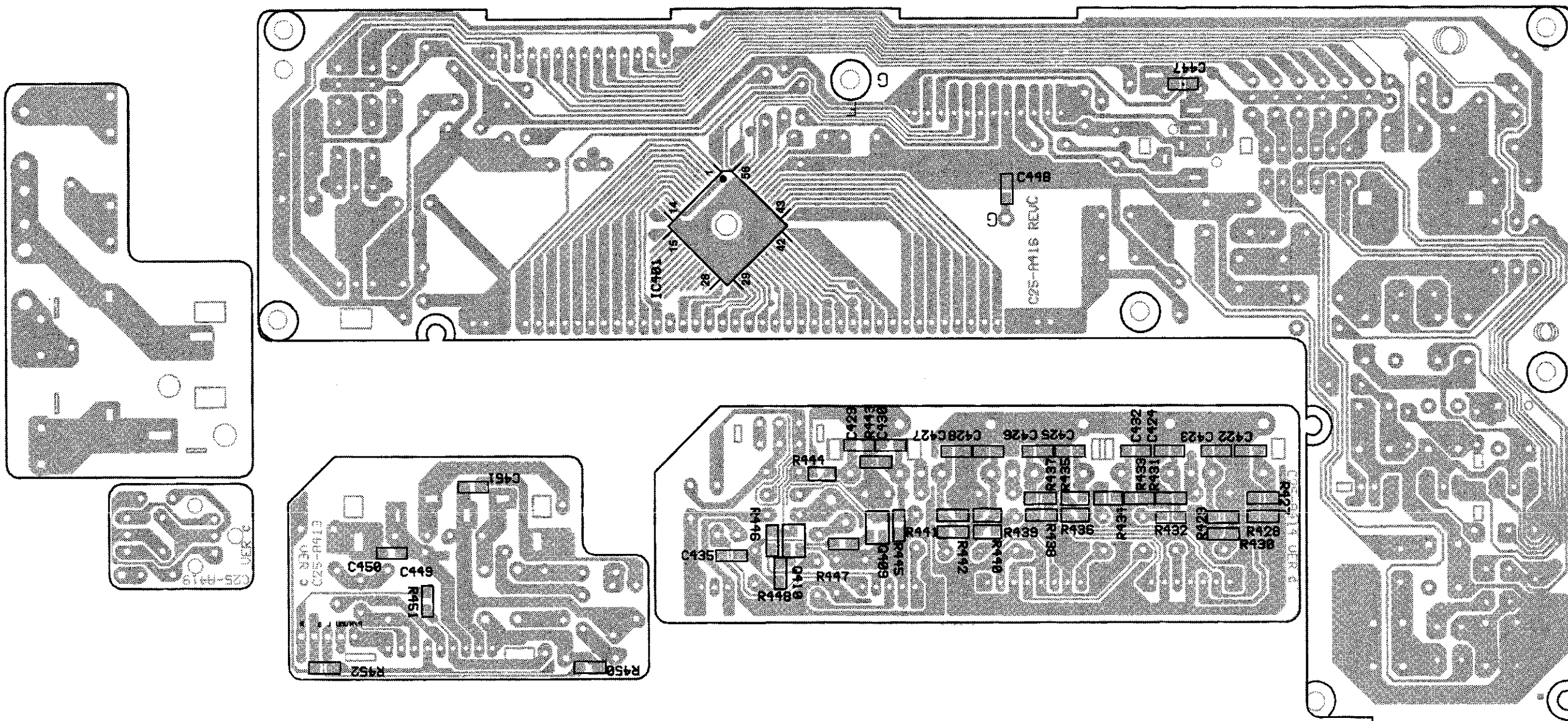

FOIL SIDE



1 2 3 4 5 6 7 8

A  
B  
C  
D  
E

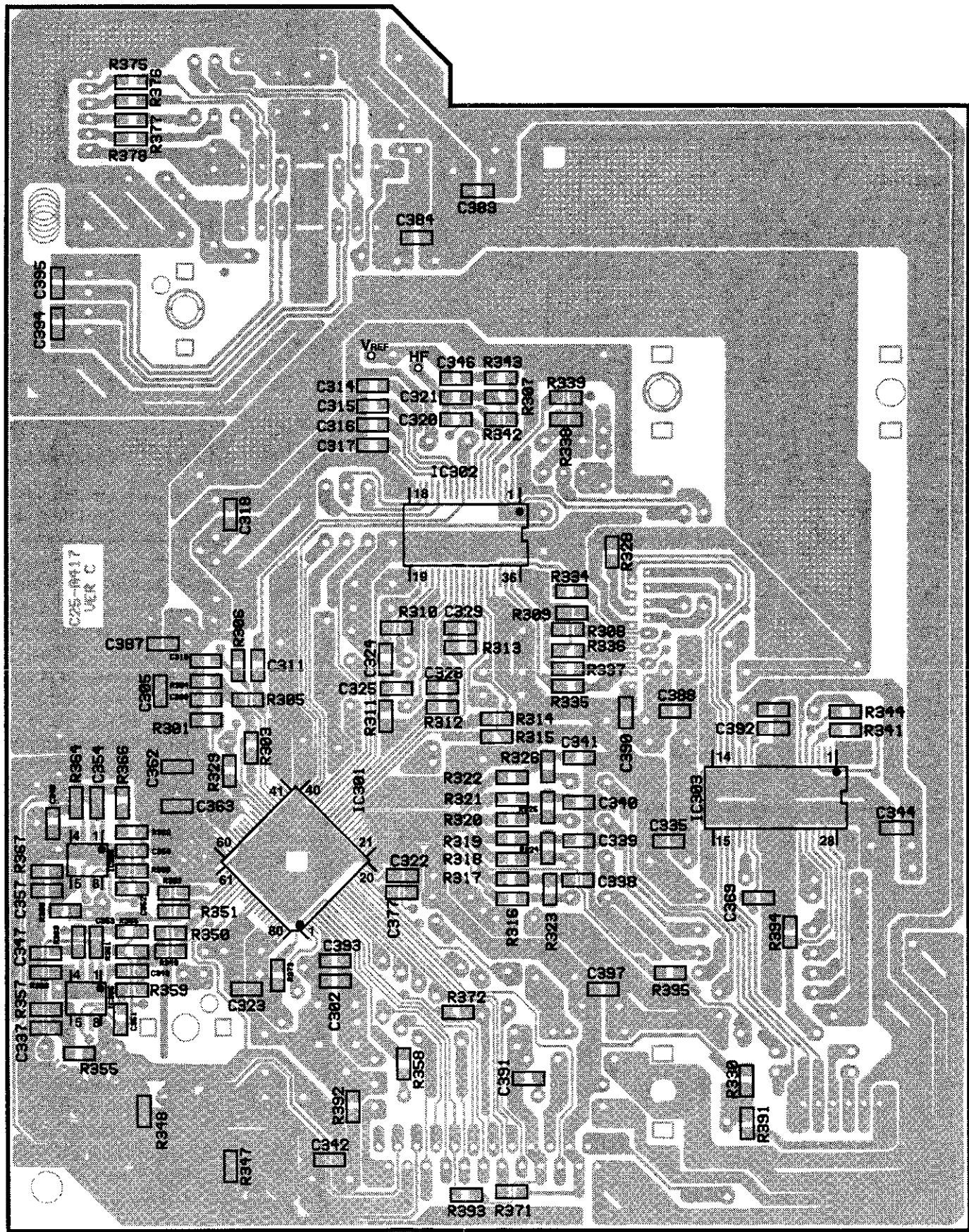

FOIL SIDE



### NOTE FOR PARTS LIST

- Part indicated with the mark "⊙" are not always in stock and possibly to take a long period of time for supplying, or in some case supplying of part may be refused.
- When ordering of part, clearly indicate "1" and "I" (i) to avoid mis-supplying.
- Ordering part without stating its part number can not be supplied.
- Part indicated with the mark "★" is not illustrated in the exploded view.
- Not including Carbon Film ±5%, 1/4W Type in the P.W.Board parts list. (Refer to the Schematic Diagram for those parts.)

**WARNING:**

Parts marked with this symbol  have critical characteristics. Use ONLY replacement parts recommended by the manufacturer.

● **Resistors**

Ex.: **RN** **14K** **2E** **182** **G** **FR**  
 Type Shape Power Resist- Allowable Others  
 and per- ance error  
 formance

RD : Carbon	2B : 1/8W	F : ±1%	P : Pulse-resistant type
RC : Composition	2E : 1/4W	G : ±2%	NL : Low noise type
RS : Metal oxide film	2H : 1/2W	J : ±5%	NB : Non-burning type
RW : Winding	3A : 1W	K : ±10%	FR : Fuse-resistor
RN : Metal film	3D : 2W	M : ±20%	F : Lead wire forming
RK : Metal mixture	3H : 5W		

\* **Resistance**

$\overset{1}{\text{R}}\overset{2}{\text{R}} \Rightarrow 1800 \text{ ohm} = 1.8 \text{ kohm}$   
 Indicates number of zeros after effective number.  
 2-digit effective number.

• Units: ohm

$\overset{1}{\text{R}}\overset{2}{\text{R}} \Rightarrow 1.2 \text{ ohm}$   
 1-digit effective number.  
 2-digit effective number, decimal point indicated by R.

• Units: ohm

● **Capacitors**

Ex.: **CE** **04W** **1H** **2B2** **M** **BP**  
 Type Shape Dielectric Capacity Allowable Others  
 and per- strength error  
 formance

CE : Aluminum foil electrolytic	0J : 6.3V	F : ±1%	HS : High stability type
CA : Aluminum solid electrolytic	1A : 10V	G : ±2%	BP : Non-polar type
CS : Tantalum electrolytic	1C : 16V	J : ±5%	HR : Ripple-resistant type
CQ : Film	1E : 25V	K : ±10%	DL : For change and discharge
CK : Ceramic	1V : 35V	M : ±20%	HF : For assuring high frequency
CC : Ceramic	1H : 50V	Z : +80%	U : UL part
CP : Oil	2A : 100V	-20%	C : CSA part
CM : Mica	2B : 125V	P : +100%	W : UL-CSA type
CF : Metallized	2C : 160V	-0%	F : Lead wire forming
CH : Metallized	2D : 200V	C : ±0.25pF	
	2E : 250V	D : ±0.5pF	
	2H : 500V	= : Others	
	2J : 630V		

\* **Capacity (electrolyte only)**

$\overset{2}{\text{R}}\overset{2}{\text{R}} \Rightarrow 2200\mu\text{F}$   
 Indicates number of zeros after effective number.  
 2-digit effective number.

• Units: μF.

$\overset{2}{\text{R}}\overset{2}{\text{R}} \Rightarrow 2.2\mu\text{F}$   
 1-digit effective number.  
 2-digit effective number, decimal point indicated by R.

• Units: μF.

\* **Capacity (except electrolyte)**

$\overset{2}{\text{R}}\overset{2}{\text{R}} \Rightarrow 2200\text{pF}=0.0022\mu\text{F}$   
 (More than 2) — Indicates number of zeros after effective number.  
 2-digit effective number.

• Units: μF.

$\overset{2}{\text{R}}\overset{2}{\text{R}} \Rightarrow 220\text{pF}$   
 (0 or 1) — Indicates number of zeros after effective number.  
 2-digit effective number.

• Units: pF.

• When the dielectric strength is indicated in AC, "AC" is included after the dielectric strength value.

### PARTS LIST OF P.W.B. UNIT ASS'Y MAIN P.W.B. ASS'Y

Note: The symbols in the column "Remarks" indicate the following destinations.  
 E3: U.S.A. & Canada model EK: U.K. model  
 E2: Europe model E1: Asia model

Ref. No.	Part No.	Part Name	Remarks	Ref. No.	Part No.	Part Name	Remarks
<b>SEMICONDUCTORS GROUP</b>							
IC1	262 2547 907	IC LC72720NM	RDS for E2,EK	Q41	269 0119 901	Transistor DTA124EK T96	
IC1	OPEN	for E1,E3		Q42	951 0046 005	Transistor 2SK161(Y)	for E1,E2,EK
IC2	262 2450 900	IC LC72131M	TUNER PLL	Q42	—	Jumper(D-G short, L=5mm)	for E3
IC3	951 0021 305	IC LA1844	TUNER FWAM	Q43,44	273 0414 906	Transistor 2SC3326 (A/B)	
IC4	262 2868 000	IC UPD784216AGC-112-8EU	MICON	D1,2	276 0375 002	Diode 1N4148	
IC5	951 0011 904	IC LC75342M	SEL/VOL/TONE	D3,4	951 0021 703	Diode SVC321SP-A2	
IC6	263 0615 902	IC BA15218F	OPE. AMP	D5	GP6 0004 002	Diode 1N4004	
IC7	262 1875 900	IC BU4066BCF	ANALOG SW	D6-8	276 0375 002	Diode 1N4148	
IC8	263 0615 902	IC BA15218F	OPE. AMP	D9-13	GP6 0004 002	Diode 1N4004	
IC9	951 0011 807	IC 93LC86/A	EEPROM	D14-17	GP6 0004 002	Diode 1N4004	
IC10	951 0012 107	IC STK405-050A	POWER IC	D18,20	GP6 0004 002	Diode 1N4004	
IC11	951 0045 802	IC BA12ST	12V	D21	276 0375 002	Diode 1N4148	
IC12	263 0553 006	IC NJM7805FA	5V	D22,23	GP6 0004 002	Diode 1N4004	
IC13	263 0516 001	IC NJM7812FA	12V	D24-29	276 0375 002	Diode 1N4148	
IC14	263 0553 006	IC NJM7805FA	5V				
IC15	951 0046 403	IC MN1280Q	RESET IC	ZD1	276 0664 904	Zener diode MTZJ5.6B T77	
△ICP1,3	268 0073 903	IC protector ICP-N15T	IC PROTECTOR	ZD2	276 0635 917	Zener diode MTZJ9.1C T77	
△ICP4	268 0073 905	IC protector ICP-N15T	IC PROTECTOR	ZD3	276 0637 902	Zener diode MTZJ6.2A T77	
Q1	GP3 8002 008	Transistor 2SC2120Y		ZD4	276 0645 965	Zener diode MTZJ33A T77	
Q2	GP3 8002 014	Transistor 2SC536GSP		ZD5	276 0637 902	Zener diode MTZJ6.2A T77	
Q3	273 0438 908	Transistor 2SC2413K		ZD6	951 0047 907	Zener diode MTZJ5.1C T77	
Q4	269 0102 905	Transistor DTC124EKT146		ZD7,8	276 0644 908	Zener diode MTZJ6.8A T77	
Q5-8	269 0066 902	Transistor DTC323TKT96		ZD9	276 0644 966	Zener diode MTZJ12A T77	
Q9	269 0102 905	Transistor DTC124EKT146		ZD10	951 0047 800	Zener diode MTZJ5.1B T77	
Q10	269 0119 901	Transistor DTA124EK T96		<b>RESISTORS GROUP</b>			
Q11	951 0029 705	Transistor 2SA1346		R1		Carbon chip 10 kohm 1/10W	RM73B--103JT
Q12	273 0384 900	Transistor 2SC2412KT96(S)		R4-6		Carbon chip 10 kohm 1/10W	RM73B--103JT
Q13	GP3 8002 021	Transistor 2SA1179		R7		Carbon chip 5.6 kohm 1/10W	RM73B--562JT
Q14	951 0019 906	Transistor HIT5610		R8		Carbon chip 10 kohm 1/10W	RM73B--103JT
Q15	273 0384 900	Transistor 2SC2412KT96(S)		R11		Carbon film 470 ohm 1/2W	RD14B2H471J
Q16	269 0102 905	Transistor DTC124EKT146		R13		Carbon chip 470 kohm 1/10W	RM73B--474JT
Q17	269 0066 902	Transistor DTC323TKT96		R14		Carbon chip 10 kohm 1/10W	RM73B--103JT
Q18	269 0102 905	Transistor DTC124EKT146		R15		Carbon chip 220 ohm 1/10W	RM73B--221JT
Q19	269 0088 906	Transistor DTC114TKT96		R17		Carbon chip 0 ohm 1/10W	RM73B--0R0JT
Q20	269 0066 902	Transistor DTC323TKT96					for E1,E2,EK
Q21	269 0185 906	Transistor DTA115TKAT146		R17		Carbon chip 82 ohm 1/10W	RM73B--820JT
Q23	269 0160 905	Transistor DTC143ZSATP					for E3
Q25,26	273 0384 900	Transistor 2SC2412KT96(S)		R18		Carbon chip 390 ohm 1/10W	RM73B--391JT
Q27	GP3 8002 021	Transistor 2SA1179		R20		Carbon chip 2.2 kohm 1/10W	RM73B--222JT
Q28	269 0160 905	Transistor DTC143ZSATP		R21		Carbon chip 470 ohm 1/10W	RM73B--471JT
Q29	273 0384 900	Transistor 2SC2412KT96(S)		R22		Carbon chip 2.2 kohm 1/10W	RM73B--222JT
Q30	273 0414 906	Transistor 2SC3326 (A/B)		R23		Carbon chip 3.3 kohm 1/10W	RM73B--332JT
Q31	272 0025 907	Transistor 2SB567(C)TF		R24-26		Carbon chip 1 kohm 1/10W	RM73B--102JT
Q32	273 0414 906	Transistor 2SC3326 (A/B)		R27		Carbon chip 220 ohm 1/10W	RM73B--221JT
Q35	269 0102 905	Transistor DTC124EKT146		R28		Carbon chip 2.7 kohm 1/10W	RM73B--272JT
Q36	269 0119 901	Transistor DTA124EK T96		R29		Carbon chip 330 ohm 1/10W	RM73B--331JT
Q38	269 0106 901	Transistor DTA144TKT146		R33,34		Carbon chip 10 kohm 1/10W	RM73B--103JT
Q39	269 0082 902	Transistor DTC114EKT96		R35		Carbon chip 1 kohm 1/10W	RM73B--102JT
Q40	269 0106 901	Transistor DTA144TKT146		R36-42		Carbon chip 22 kohm 1/10W	RM73B--223JT
				R43		Carbon chip 10 kohm 1/10W	RM73B--103JT

Ref. No.	Part No.	Part Name	Remarks	Ref. No.	Part No.	Part Name	Remarks
R44		Carbon chip 3.3 kohm 1/10W	RM73B--332JT	R100		Carbon chip 220 ohm 1/10W	RM73B--221JT
R45		Carbon chip 47 kohm 1/10W	RM73B--473JT	R101,102		Carbon chip 2.2 kohm 1/10W	RM73B--222JT
R46-52		Carbon chip 1 kohm 1/10W	RM73B--102JT	R103,104		Carbon chip 22 kohm 1/10W	RM73B--223JT
R54		Carbon chip 0 ohm 1/10W	RM73B--0R0JT	R105		Carbon chip 10 kohm 1/10W	RM73B--103JT
R55		Carbon chip 47 kohm 1/10W	RM73B--473JT	R106		Carbon chip 3.3 kohm 1/10W	RM73B--332JT
R56		Carbon chip 0 ohm 1/10W	RM73B--0R0JT	R107		Carbon chip 4.7 kohm 1/10W	RM73B--472JT
R57		Carbon chip 47 kohm 1/10W	RM73B--473JT	R108		Carbon chip 47 kohm 1/10W	RM73B--473JT
R58		Carbon chip 18 kohm 1/10W	RM73B--183JT	R109		Carbon film 3.3 kohm 1/2W	RD14B2H332J
R59		Carbon chip 10 kohm 1/10W	RM73B--103JT	R110		Carbon chip 100 kohm 1/10W	RM73B--104JT
R60		Carbon chip 6.8 kohm 1/10W	RM73B--682JT	R111		Carbon chip 2.2 kohm 1/10W	RM73B--222JT
R61		Carbon chip 100 kohm 1/10W	RM73B--104JT	R112		Carbon chip 1 kohm 1/10W	RM73B--102JT
R62		Carbon chip 3.3 kohm 1/10W	RM73B--332JT	R113		Carbon chip 22 kohm 1/10W	RM73B--223JT
R63-66		Carbon chip 2.2 kohm 1/10W	RM73B--222JT	R114		Carbon chip 2.2 kohm 1/10W	RM73B--222JT
R67		Carbon chip 47 kohm 1/10W	RM73B--473JT	R115		Carbon chip 10 kohm 1/10W	RM73B--103JT
R68		Carbon chip 10 kohm 1/10W	RM73B--103JT	R116,117		Carbon chip 2.2 kohm 1/10W	RM73B--222JT
R69		Carbon chip 47 kohm 1/10W	RM73B--473JT	R118		Carbon chip 1 kohm 1/10W	RM73B--102JT
R70-73		Carbon chip 1 kohm 1/10W	RM73B--102JT	R120		Carbon chip 2.2 kohm 1/10W	RM73B--222JT
R74,75		Carbon chip 10 kohm 1/10W	RM73B--103JT	R121		Carbon chip 1 kohm 1/10W	RM73B--102JT
R76		Carbon chip 4.7 kohm 1/10W	RM73B--472JT	R122		Carbon chip 22 kohm 1/10W	RM73B--223JT
R76	OPEN		for E3	R123		Carbon chip 10 kohm 1/10W	RM73B--103JT
R77		Carbon chip 4.7 kohm 1/10W	RM73B--472JT	R126,127		Carbon chip 4.7 kohm 1/10W	RM73B--472JT
R77	OPEN		for E1,E2,EK	R128		Carbon chip 7.5 kohm 1/10W	RM73B--752JT
R78	OPEN		for E1,E2,EK	R129		Carbon chip 2.2 kohm 1/10W	RM73B--222JT
R79		Carbon chip 4.7 kohm 1/10W	RM73B--472JT	R130		Carbon chip 100 kohm 1/10W	RM73B--104JT
R79	OPEN		for E1,E3	R131		Carbon chip 100 ohm 1/10W	RM73B--101JT
R80		Carbon chip 4.7 kohm 1/10W	RM73B--472JT	R133		Carbon chip 10 kohm 1/10W	RM73B--103JT
R80	OPEN		for E2,EK	R134		Carbon chip 2.2 kohm 1/10W	RM73B--222JT
R81		Carbon chip 47 ohm 1/10W	RM73B--470JT	R135		Carbon chip 1 kohm 1/10W	RM73B--102JT
R82		Carbon chip 4.7 kohm 1/10W	RM73B--472JT	R136,137		Carbon chip 100 kohm 1/10W	RM73B--104JT
R83		Carbon chip 4.7 kohm 1/10W	RM73B--472JT	R138		Carbon chip 2.2 kohm 1/10W	RM73B--222JT
R83	OPEN		for E2,EK	R139		Carbon chip 10 kohm 1/10W	RM73B--103JT
R84		Carbon chip 4.7 kohm 1/10W	RM73B--472JT	R140		Carbon chip 100 kohm 1/10W	RM73B--104JT
R84	OPEN		for E1,E3	R141		Carbon chip 7.5 kohm 1/10W	RM73B--752JT
R85		Carbon chip 4.7 kohm 1/10W	RM73B--472JT	R142		Carbon chip 100 kohm 1/10W	RM73B--104JT
R86		Carbon chip 5.6 kohm 1/10W	RM73B--562JT	R144		Carbon chip 2.2 kohm 1/10W	RM73B--222JT
R87		Carbon chip 220 kohm 1/10W	RM73B--224JT	R145		Carbon chip 100 kohm 1/10W	RM73B--104JT
R89		Carbon chip 100 kohm 1/10W	RM73B--104JT	R146		Carbon chip 10 kohm 1/10W	RM73B--103JT
R90		Carbon chip 68 kohm 1/10W	RM73B--683JT	R147		Carbon chip 1 kohm 1/10W	RM73B--102JT
R91		Carbon chip 100 kohm 1/10W	RM73B--104JT	R149,150		Carbon chip 10 kohm 1/10W	RM73B--103JT
R92		Carbon chip 2.2 kohm 1/10W	RM73B--222JT	R152		Carbon chip 10 kohm 1/10W	RM73B--103JT
R93		Carbon chip 3.3 kohm 1/10W	RM73B--332JT	R153		Carbon chip 47 kohm 1/10W	RM73B--473JT
R94,95		Carbon chip 22 kohm 1/10W	RM73B--223JT	R156	242 0074 008	Composition 2.7 Mohm 1/2W	RC05GF2H275K
R96		Carbon chip 10 kohm 1/10W	RM73B--103JT		OPEN		for E3
R97		Carbon chip 4.7 kohm 1/10W	RM73B--472JT	R155,158		Carbon chip 10 kohm 1/10W	RM73B--103JT
R98,99		Carbon chip 1.5 kohm 1/10W	RM73B--152JT	R159		Carbon chip 22 kohm 1/10W	RM73B--223JT
				R162,163		Carbon chip 10 kohm 1/10W	RM73B--103JT
				R164	244 2043 953	Metal film 470 ohm 1W	RS14B3A471JNBST(S)
				R165		Carbon chip 1 kohm 1/10W	RM73B--102JT
				R166		Carbon chip 22 kohm 1/10W	RM73B--223JT
				R167		Carbon chip 56 kohm 1/10W	RM73B--563JT
				R168		Carbon chip 1 kohm 1/10W	RM73B--102JT

Ref. No.	Part No.	Part Name	Remarks	Ref. No.	Part No.	Part Name	Remarks
R169,170		Carbon chip 10 kohm 1/10W	RM73B--103JT	C16	OPEN		for E1,E3
R171	244 2043 953	Metal film 470 ohm 1W	RS14B3A471JNBST(S)	C17		Ceramic chip 0.047μF/50V	
R173		Carbon chip 56 kohm 1/10W	RM73B--563JT	C18		Ceramic chip 22pF/50V(NP0)	CC73CH1H220JT
R174,176	241 2313 901	Fusible 100 ohm 1/4W	RD14B2E101GFRST	C19		Ceramic chip 27pF/50V(NP0)	CC73CH1H270JT
R177		Carbon chip 2.7 kohm 1/10W	RM73B--272JT	C20		Ceramic chip 0.01μF/50V	for E2,EK
R178		Carbon chip 56 kohm 1/10W	RM73B--563JT	C20	OPEN		for E1,E3
R179		Carbon chip 2.7 kohm 1/10W	RM73B--272JT	C21		Ceramic chip 22pF/50V	CC73CH1H220JT
R180,181	244 2043 937	Metal film 10 ohm 1W	RS14B3A100JNBST(S)				for E2,EK
R182		Carbon chip 56 kohm 1/10W	RM73B--563JT	C21	OPEN		for E1,E3
R185,186		Carbon chip 2.2 kohm 1/10W	RM73B--222JT	C22		Ceramic chip 0.1μF/50V	
R188		Carbon chip 4.7 kohm 1/10W	RM73B--472JT	C23		Ceramic chip 100pF/50V	
R189		Carbon chip 330 ohm 1/10W	RM73B--331JT	C24		Ceramic chip 0.01μF/50V	
R189	OPEN		for E1,E2,EK	C25,26		Electrolytic 1μF/50V	
R190		Carbon chip 390 ohm 1/10W	RM73B--391JT	C27		Ceramic chip 0.01μF/50V	
R190		Carbon chip 1k ohm 1/10W	RM73B--102JT	C28		Electrolytic 10μF/25V	
R191		Carbon chip 0 ohm 1/10W	RM73B--0R0JT	C29		Electrolytic 100μF/10V	
R192,193		Carbon chip 10 kohm 1/10W	RM73B--103JT	C30		Electrolytic 100μF/16V	
R194		Carbon chip 4.7 kohm 1/10W	RM73B--472JT	C31		Ceramic chip 330pF/50V	for E2,EK
R195		Carbon chip 47 kohm 1/10W	RM73B--473JT	C31	OPEN		for E1,E3
R196,197		Carbon chip 2.2 kohm 1/10W	RM73B--222JT	C32		Ceramic chip 560pF/50V	for E2,EK
R198		Carbon chip 100 kohm 1/10W	RM73B--104JT	C32	OPEN		for E1,E3
R199		Carbon chip 5.1 ohm 1/10W	RM73B--5R1KT	C33		Electrolytic 0.47μF/50V	
R200	244 2051 945	Metal oxide 1 ohm 1W	RS14B3A010JNBST(S)	C34	254 3056 904	Electrolytic 0.47μF/50V(BP)	CD04D1HR47MBPT
R201		Carbon chip 2 kohm 1/10W	RM73B--202JT	C35		Ceramic chip 0.1μF/50V	
R202,203		Carbon chip 47 kohm 1/10W	RM73B--473JT	C36		Electrolytic 47μF/25V	for E2,EK
R204,205	244 2055 941	Metal oxide 330 ohm 1W	RS14B3A331JNBST(S)	C36	OPEN		for E1,E3
<b>CAPACITORS GROUP</b>				C37		Ceramic chip 0.047μF/50V	
C1		Electrolytic 10μF/25V		C38		Ceramic chip 0.1μF/50V	
C2		Ceramic chip 0.1μF/50V		C40		Ceramic chip 0.022μF/50V	
C3		Electrolytic 1μF/50V	CE04W1H010MT	C41		Electrolytic 10μF/25V	
C3	OPEN		for E2,EK	C45		Ceramic chip 0.047μF/50V	
C5		Electrolytic 47μF/16V	for E1,E3	C46		Ceramic chip 820pF/50V	
C6		Electrolytic 100μF/10V		C47,48		Ceramic chip 0.0047μF/50V	
C7		Electrolytic 100μF/16V		C49		Electrolytic 1μF/50V	
C8		Ceramic chip 22pF/50V(NP0)	CC73CH1H220JT	C51		Ceramic chip 0.1μF/50V	
C8	OPEN		for E2,EK	C52		Electrolytic 10μF/25V	
C9		Electrolytic 47μF/16V	for E1,E3	C54		Electrolytic 4.7μF/50V	
C10		Ceramic chip 100pF/50V		C55		Ceramic chip 0.047μF/50V	
C11		Ceramic chip 27pF/50V(NP0)	CC73CH1H270JT	C56		Electrolytic 10μF/25V	
C12		Ceramic chip 0.001μF/50V	for E2,EK	C57,58		Ceramic chip 0.1μF/50V	
C12	OPEN		for E1,E3	C60		Ceramic chip 0.1μF/50V	
C13		Ceramic chip 50pF/50V		C61		Ceramic chip 0.0047μF/50V	
C14		Ceramic chip 0.1μF/50V		C62		Electrolytic 1μF/50V	
C15		Ceramic chip 100pF/50V		C64,65		Ceramic chip 100pF/50V	
C16		Electrolytic 10μF/50V	for E2,EK	C66-69		Electrolytic 4.7μF/50V	
				C70		Electrolytic 100μF/10V	
				C71,72		Ceramic chip 100pF/50V	
				C74		Electrolytic 10μF/25V	
				C75		Polystyrene 350pF/50V	CQ08S1H351J
				C76		Ceramic 0.02μF/50V	CK45F1H203ZT
				C77		Ceramic chip 0.1μF/50V	
				C79		Ceramic chip 0.022μF/50V	

Ref. No.	Part No.	Part Name	Remarks	Ref. No.	Part No.	Part Name	Remarks
C80	253 1181 904	Ceramic 0.01 $\mu$ F/50V	CK45F1H103ZT	C144		Electrolytic 22 $\mu$ F/25V	
C81		Electrolytic 4.7 $\mu$ F/50V		C145		Ceramic chip 0.001 $\mu$ F/50V	
C82		Ceramic chip 0.022 $\mu$ F/50V		C146,147		Ceramic chip 100pF/50V	
C83		Ceramic chip 7pF/50V(NP0)	CC73CH1H070JT	C148		Ceramic 0.01 $\mu$ F/50V	
C84		Electrolytic 100 $\mu$ F/50V		C149,150		Electrolytic 4.7 $\mu$ F/50V	
C85		Ceramic chip 100pF/50V		C151,152	253 1181 904	Ceramic 0.01 $\mu$ F/50V	CK45F1H103ZT
C86		Ceramic chip 47pF/50V		C153	254 4403 721	Electrolytic 2200 $\mu$ F/25V	CE04W1E222MC
C87		Electrolytic 4.7 $\mu$ F/50V		C154		Ceramic chip 0.1 $\mu$ F/50V	
C88		Ceramic chip 0.1 $\mu$ F/50V		C155	253 1181 904	Ceramic 0.01 $\mu$ F/50V	CK45F1H103ZT
C89		Electrolytic 4.7 $\mu$ F/50V		C156		Electrolytic 10 $\mu$ F/25V	
C90		Electrolytic 22 $\mu$ F/25V		C157,158	253 1181 904	Ceramic 0.01 $\mu$ F/50V	CK45F1H103ZT
C91		Electrolytic 4.7 $\mu$ F/50V		C169	253 1181 904	Ceramic 0.01 $\mu$ F/50V	CK45F1H103ZT
C92		Electrolytic 47 $\mu$ F/16V		C159		Ceramic chip 0.1 $\mu$ F/50V	
C93,94		Ceramic chip 0.0027 $\mu$ F/50V		C160		Ceramic chip 0.047 $\mu$ F/50V	
C95,96		Ceramic chip 0.1 $\mu$ F/50V		C161		Electrolytic 330 $\mu$ F/10V	
C97,98		Ceramic chip 0.1 $\mu$ F/50V		C162		Electrolytic 10 $\mu$ F/50V	
C99		Ceramic chip 5pF/50V		C163		Ceramic chip 470pF/50V	
C101		Ceramic chip 0.1 $\mu$ F/50V		C164	254 3056 946	Electrolytic 4.7 $\mu$ F/50V(BP)	CE04D1H4R7MBPT
C102		Ceramic chip 0.001 $\mu$ F/35V		C165		Ceramic chip 470pF/50V	
C103		Electrolytic 4700 $\mu$ F/35V	CE04W1V472M	C166		Electrolytic 100 $\mu$ F/35V	
C104		Electrolytic 22 $\mu$ F/25V		C167	254 3056 946	Electrolytic 4.7 $\mu$ F/50V(BP)	CE04D1H4R7MBPT
C105,106		Ceramic chip 0.1 $\mu$ F/50V		C168		Ceramic chip 470pF/50V	
C107		Electrolytic 10 $\mu$ F/50V		C170		Electrolytic 10 $\mu$ F/50V	
C108		Electrolytic 4.7 $\mu$ F/50V		C171		Ceramic chip 470pF/50V	
C109		Ceramic chip 100pF/50V		C172		Ceramic chip 0.1 $\mu$ F/50V	
C110		Ceramic chip 47pF/50V		C173		Electrolytic 22 $\mu$ F/50V	
C111		Electrolytic 4.7 $\mu$ F/50V		C174		Electrolytic 100 $\mu$ F/35V	
C112		Ceramic chip 0.001 $\mu$ F/50V		C175		Electrolytic 22 $\mu$ F/50V	
C113		Ceramic chip 0.1 $\mu$ F/50V		C176		Ceramic chip 10pF/50V(NP0)	CC73CH1H100JT
C114	253 1181 904	Ceramic 0.01 $\mu$ F/50V	CK45F1H103ZT	C177~179		Electrolytic 10 $\mu$ F/50V	
C115		Electrolytic 4.7 $\mu$ F/50V		C180		Ceramic chip 10pF/50V(NP0)	CC73CH1H100JT
C116		Electrolytic 22 $\mu$ F/25V		C181~188		Ceramic chip 0.01 $\mu$ F/50V	
C117		Ceramic chip 100pF/50V		C189		Ceramic chip 0.1 $\mu$ F/50V	
C118		Ceramic chip 0.1 $\mu$ F/50V		C190		Electrolytic 10 $\mu$ F/50V	
C120		Ceramic chip 100pF/50V		C191		Electrolytic 10 $\mu$ F/25V	
C121~123	253 1181 904	Ceramic 0.01 $\mu$ F/50V	CK45F1H103ZT	C192,193		Ceramic chip 0.047 $\mu$ F/50V	for E1,E2,EK
C124		Electrolytic 4.7 $\mu$ F/50V		C192,193		Ceramic chip 0.068 $\mu$ F/50V	for E3
C125		Electrolytic 47 $\mu$ F/16V		C194,195		Electrolytic 4.7 $\mu$ F/50V	
C126,127		Ceramic chip 100pF/50V		C196		Ceramic chip 0.1 $\mu$ F/50V	
C128		Electrolytic 4.7 $\mu$ F/50V		C197		Ceramic chip 0.01 $\mu$ F/50V	
C129,130	253 1181 904	Ceramic 0.01 $\mu$ F/50V	CK45F1H103ZT	C198,199	253 1181 904	Ceramic 0.01 $\mu$ F/50V	CK45F1H103ZT
C131		Ceramic chip 100pF/50V		C200		Electrolytic 10 $\mu$ F/25V	
C132,133		Ceramic chip 0.1 $\mu$ F/50V		C201		Ceramic 4700pF/250V	CK45F2EAC472M
C134		Electrolytic 22 $\mu$ F/25V		C202		Electrolytic 10 $\mu$ F/25V	
C135		Electrolytic 4700 $\mu$ F/35V	CE04W1V472M	C203,204		Ceramic chip 0.001 $\mu$ F/50V	
C136,137		Ceramic chip 100pF/50V		C205		Electrolytic 10 $\mu$ F/25V	
C138,139		Electrolytic 4.7 $\mu$ F/50V		C206		Electrolytic 100 $\mu$ F/10V	
C140		Ceramic chip 0.001 $\mu$ F/50V		C207,208		Ceramic chip 0.22 $\mu$ F/50V	
C141		Electrolytic 4.7 $\mu$ F/50V		C209	254 3056 920	Electrolytic 2.2 $\mu$ F/50V(BP)	CE04D1H2R2MBPT
C142	253 1181 904	Ceramic 0.01 $\mu$ F/50V	CK45F1H103ZT	C210		Ceramic chip 0.1 $\mu$ F/50V	
C143		Electrolytic 4700 $\mu$ F/35V	CE04W1V472M	C211,212		Ceramic chip 100pF/50V	

Ref. No.	Part No.	Part Name	Remarks	Q'ty	Ref. No.	Part No.	Part Name	Remarks	Q'ty
C213,214	253 9037 908	Ceramic 0.1 $\mu$ F/50V	CK45=1H104ZT		RF1	951 0046 500	FM tuner module KCF217V	FM FRONTEND for E1,E2,EK	1
C215		Ceramic chip 0.1 $\mu$ F/50V			RF1	951 0051 605	FM tuner module KCF216V	FM FRONTEND for E3	1
C217		Ceramic chip 0.001 $\mu$ F/50V			RL1	214 0202 009	RELAY DG1U TV8	AC RELAY	1
C219		Ceramic chip 0.01 $\mu$ F/50V			T1	951 0019 508	AM IF COIL	AM IFT	1
C220		Ceramic chip 0.1 $\mu$ F/50V			T2	951 0019 207	FM DETECTOR IFT	FM DET TRANS	1
C221		Ceramic chip 0.01 $\mu$ F/50V			T3,4	951 0030 901	FM MPX 19kHz FILTER	FM MPX FILTER for E1,E2,EK	2
C222	253 1181 904	Ceramic 0.01 $\mu$ F/50V	CK45F1H103ZT		T3,4	—	Jumper(IN-OUT short, L=10mm)	for E3	
C224~226	253 4538 949	Ceramic 100pF/50V	CC45SL1H101JT		T5	951 0019 401	AM ANTENNA COIL	AM ANTENNA COIL	1
C227		Ceramic chip 100pF/50V			T6	951 0019 605	AM OSCILATOR COIL	AM OSCILATOR COIL	1
C228		Ceramic chip 0.001 $\mu$ F/50V			TC1	951 0020 005	TRIMMER CAP.	AM ANTENNA TRIMMER	1
<b>OTHER PARTS GROUP</b>				<b>Q'ty</b>	XTL1	951 0020 801	Crystal 7.2000MHz	for PLL	1
CF1	951 0020 500	Ceramic filter SFZ450B	AM CERAMIC FILTER	1	XTL2	951 0011 603	Crystal 4.332MHz	for RDS, for E2,EK	1
CF2	261 0064 007	Ceramic filter SFT10.7MS2-A	FM CERAMIC FILTER for E1,E2,EK	1	XTL2	OPEN		for E3	
CF2	261 0135 907	Ceramic filter SFE10.7MA8-A	FM CERAMIC FILTER for E3	1	XTL3	951 0046 209	Ceramic Resonator 12.5MHz	for MICON	1
CF3	261 0064 007	Ceramic filter SFT10.7MS2-A	FM CERAMIC FILTER for E1,E2,EK	1	A.	951 0011 001	Sub trans	for E1,E2,EK	1
CF3	261 0136 906	Ceramic filter SFE10.7MS2G-A	FM CERAMIC FILTER for E3	1	A.	233 6355 003	Power trans(sub)E3	for E3	1
H1	951 0051 508	24P FFC connector base	MSA-9604S-24C	1	—	—	1P wire ass'y L=40mm (3T LUG)		1
H3	205 0343 087	8P PH connector base		1	—	—	1P wire ass'y L=50mm (3T LUG)		1
H4	951 0051 906	4P PH connector cord		1	—	—	1P wire ass'y L=100mm(3T LUG)		1
H5	205 0480 047	14P PH connector base(S)		1	—	—	1P wire UL1007 AWG22 BK L=40mm		3
H6	951 0051 809	7P PH-SAN connector cord		1	—	—	1P wire UL1007 AWG22 BK L=100mm		1
H7	205 0190 052	5P NH connector base		1	—	—	1P wire UL1007 AWG22 BK L=110mm		2
H8	951 0051 702	8P PH-SAN connector cord		1	—	—	1P wire UL1007 AWG22 BK L=150mm		1
H9	205 0480 021	12P PH connector base(S)		1	—	—	1P wire UL1007 AWG22 BK L=170mm		1
H10	205 0653 036	3P VH connector base		1	—	—	1P wire UL1007 AWG22 BK L=200mm		2
H11	951 0052 002	9P PH-SAN connector cord		1	951 0049 400		P.W.B bracket		2
H12,13	205 0581 001	2P VH connector base		2	951 9002 118		Screw 3 $\times$ 6 CBTS(P)-Z		2
JK1	951 0045 909	FM/AM ANT. TERMINAL(PAL/F)		1					
JK2,3	951 0010 808	Mini jack		2					
L1,2	235 0104 007	Inductor 1 $\mu$ H		2					
L3	GP3 8002 049	Inductor 10 $\mu$ H	for E2,EK	1					
L3	OPEN		for E1,E3						
L4	951 0046 102	Inductor 4.7 $\mu$ H	for E2,EK	1					
L4	OPEN		for E1,E3						
L5,6	GP3 8002 049	Inductor 10 $\mu$ H		3					
L7	GP3 8002 049	Inductor 10 $\mu$ H	for E2,EK						
L7	OPEN		for E1,E3						

## DISPLAY P.W.B. ASS'Y

Ref. No.	Part No.	Part Name	Remarks	Ref. No.	Part No.	Part Name	Remarks
<b>SEMICONDUCTORS GROUP</b>				C425,426		Ceramic chip 0.001 $\mu$ F/50V	
IC402	499 0301 006	IC RPM6938V-4	SENSOR	C427,428		Ceramic chip 470pF/50V	
IC401	951 0012 000	IC LC75725E	FLD DRINER	C429,430		Ceramic chip 0.001 $\mu$ F/50V	
Q401~407	GP3 8002 013	Transistor 2SC3400		C431		Ceramic 0.02 $\mu$ F/50V	CK45F1H203ZT
Q408	GP3 8002 013	Transistor 2SC3400		C432		Ceramic chip 470pF/50V	
Q409,410	269 0066 902	Transistor DTC323TK		C433	253 9039 906	Ceramic 0.1 $\mu$ F/25V	CK45=1E104ZT
D401	276 0375 002	Diode 1N4148		C434		Ceramic 0.02 $\mu$ F/50V	CK45F1H203ZT
LED401	951 0012 204	LED SLR-9336DS-91 R / G	D=5mm LED (RED/GREEN)	C435		Ceramic chip 0.1 $\mu$ F/50V	
LED402~404	951 0047 703	LED SLR-9335D8-91 R / G	D=3mm LED (RED/GREEN)	C436,437		Electrolytic 4.7 $\mu$ F/50V	
LED410	951 0045 501	LED SLBZ5VR3F (RED)	2X5 LED(RED)	C438		Electrolytic 10 $\mu$ F/25V	
<b>RESISTORS GROUP</b>				C439		Ceramic 0.02 $\mu$ F/50V	CK45F1H203ZT
R422,423	244 2051 987	Metal film 4.7 ohm 1W	S14B3A4R7JNBST(S)	C440		Ceramic chip 0.01 $\mu$ F/50V	
R427		Carbon chip 470 ohm 1/10W		C441		Electrolytic 47 $\mu$ F/16V	
R428		Carbon chip 470 kohm 1/10W		C443,445	253 9039 906	Ceramic 0.1 $\mu$ F/25V	CK45=1E104ZT
R429		Carbon chip 470 ohm 1/10W		C446	253 4538 949	Ceramic 100pF/50V	CC45SL1H101JT
R430,431		Carbon chip 470 kohm 1/10W		C447		Ceramic chip 0.1 $\mu$ F/50V	
R432		Carbon chip 470 ohm 1/10W		C449,450		Ceramic chip 0.001 $\mu$ F/50V	
R433		Carbon chip 470 kohm 1/10W		C451		Ceramic chip 0.1 $\mu$ F/50V	
R434,435		Carbon chip 470 ohm 1/10W					
R436		Carbon chip 470 kohm 1/10W					
R437		Carbon chip 470 ohm 1/10W					
R438,439		Carbon chip 470 kohm 1/10W					
R440		Carbon chip 470 ohm 1/10W					
R441		Carbon chip 470 kohm 1/10W					
R442		Carbon chip 470 ohm 1/10W					
R443,444		Carbon chip 2.7 kohm 1/10W					
R445,446		Carbon chip 30 kohm 1/10W					
R447,448		Carbon chip 2.2 kohm 1/10W					
R450~452		Carbon chip 0 ohm 1/10W					
<b>CAPACITORS GROUP</b>							
C401	253 4536 983	Ceramic 22pF/50V	CC45SL1H220JT				
C402,403	253 1180 921	Ceramic 0.001 $\mu$ F/50V	CK45B1H102KT				
C404	253 9039 906	Ceramic 0.1 $\mu$ F/25V	CK45=1E104ZT				
C405		Electrolytic 100 $\mu$ F/10V					
C406,407	253 1180 921	Ceramic 0.001 $\mu$ F/50V	CK45B1H102KT				
C408,409	253 9039 906	Ceramic 0.1 $\mu$ F/25V	CK45=1E104ZT				
C410,411	253 1180 921	Ceramic 0.001 $\mu$ F/50V	CK45B1H102KT				
C412,413		Mylar film 0.01 $\mu$ F/100V	CQ92M2A103J				
C414,415		Mylar film 0.1 $\mu$ F/100V	CQ92M2A104J				
C416	253 9039 906	Ceramic 0.1 $\mu$ F/25V	CK45=1E104ZT				
C417		Ceramic 0.02 $\mu$ F/50V	CK45F1H203ZT				
C418~421		Electrolytic 4.7 $\mu$ F/50V					
C422,423		Ceramic chip 0.001 $\mu$ F/50V					
C424		Ceramic chip 470pF/50V					

## CD P.W.B. ASS'Y

Ref. No.	Part No.	Part Name	Remarks	Q'ty
<b>OTHER PARTS GROUP</b>				
△ F1	206 1075 043	Fuse T2.5A/250V	for E1,E2,EK	1
△ F1	206 1072 088	Fuse 5A/125V	for E3	1
△ F2	206 1074 099	Fuse T800mA/250V	for E1,E2,EK	1
△ F2	951 0052 604	Fuse 2.5A/125V	for E3	1
FS1,2	202 0040 909	Fuse holder		4
H401	951 0052 109	14P PH connector cord		1
H402	951 0052 206	12P PH connector cord		1
H403	205 0343 090	9P PH connector base		1
H404	951 0052 400	5P PH-SAN connector cord		1
H405	205 0343 087	8P PH connector base		1
H406	205 0343 074	7P PH connector base		1
H407	205 0343 058	5P PH connector base		1
H409	951 0052 303	3P VH-SIN connector cord		1
H410	205 0581 001	2P VH connector base		1
H411	951 0025 819	3P connector base		1
JK401	951 0010 507	Mini jack	H/PHONE JACK	1
JK402	269 0098 006	Optical connector (GP1F32T)	OPTICAL OUT	1
△ JK403	203 3961 004	AC outlet (E2)	for E1,E2,EK	1
△ JK403	951 0031 104	AC outlet (E3)	for E3	1
JK405	951 0010 604	4P pin jack		1
JK406	951 0010 701	6P pin jack		1
JK407	951 0045 705	4P SP terminal		1
JOG401	951 0011 302	Rotary encoder REB161	VOLUME	1
RL401	214 0206 005	Relay (PC1-212DM)	SP RELAY	1
SW401-412	951 0010 905	Tact switch		12
SW413	951 0011 108	Slide switch	PRE OUT SW	1
VFD401	393 8049 004	VFD	FLD	1
	—	P.V.C. tuve 6.6mm		1
	951 9002 066	Fuse label T2.5A/250V	F1, for E1,E2,EK	1
	951 0031 421	Fuse label 5A/125V	F1, for E3	1
	951 9002 095	Fuse label T800mA/250V	F2, for E1,E2,EK	1
	951 9002 121	Fuse label 2.5A/125V	F2, for E3	1
	415 0309 055	P.V.C. tuve (L=07) 1mm		1
	951 0016 307	Sensor holder	IC402	1
	951 0047 509	LED holder		1

Ref. No.	Part No.	Part Name	Remarks
<b>SEMICONDUCTORS GROUP</b>			
IC301	262 2815 008	IC QFP MN35511	CD DSP
IC302	262 2462 901	IC AN8807SB-E1	CD DRIVER
IC303	262 2461 902	IC AN8816SB-E1	CD RF
IC305,306	263 0615 902	IC BA15218F	OPE. AMP
IC309	951 0047 208	IC LB1648	LOADER DRIVER
TR302	271 0183 972	Transistor 2SA933S	
ZD302	276 0644 908	Zener diode MTZJ6.8A T77	
ZD303	276 0643 996	Zener diode MTZJ5.6A T77	
<b>RESISTORS GROUP</b>			
R301		Carbon chip 560 ohm 1/10W	
R303		Carbon chip 100 kohm 1/10W	
R304		Carbon chip 1 Mohm 1/10W	
R305		Carbon chip 47 kohm 1/10W	
R306		Carbon chip 120 kohm 1/10W	
R307		Carbon chip 1.5 kohm 1/10W	
R308,309		Carbon chip 15 kohm 1/10W	
R310		Carbon chip 220 kohm 1/10W	
R311,312		Carbon chip 39 kohm 1/10W	
R313		Carbon chip 10 kohm 1/10W	
R314		Carbon chip 390 kohm 1/10W	
R315		Carbon chip 330 kohm 1/10W	
R316		Carbon chip 150 kohm 1/10W	
R317,318		Carbon chip 47 kohm 1/10W	
R319		Carbon chip 2.7 kohm 1/10W	
R320		Carbon chip 220 kohm 1/10W	
R321		Carbon chip 68 kohm 1/10W	
R322		Carbon chip 39 kohm 1/10W	
R323		Carbon chip 4.7 kohm 1/10W	
R324,325		Carbon chip 1.8 kohm 1/10W	
R326		Carbon chip 1 kohm 1/10W	
R328		Carbon chip 100 ohm 1/10W	
R329		Carbon chip 680 ohm 1/10W	
R330		Carbon chip 22 kohm 1/10W	
R333		Carbon chip 0 ohm 1/10W	
R334,335		Carbon chip 150 kohm 1/10W	
R336,337		Carbon chip 15 kohm 1/10W	
R338	247 0009 985	Carbon chip 10 kohm 1/10W	
R339		Carbon chip 100 ohm 1/10W	
R341		Carbon chip 0 ohm 1/10W	
R342		Carbon chip 1.8 kohm 1/10W	
R343		Carbon chip 1 kohm 1/10W	
R344		Carbon chip 0 ohm 1/10W	
R347,348	247 0009 985	Carbon chip 10 kohm 1/10W	
R349-352		Carbon chip 200 kohm 1/10W	
R355		Carbon chip 3.3 kohm 1/10W	
R356		Carbon chip 0 ohm 1/10W	
R357		Carbon chip 3.3 kohm 1/10W	
R358		Carbon chip 220 ohm 1/10W	

# WIRING DIAGRAM

1 2 3 4 5 6 7 8

A

B

C

D

E

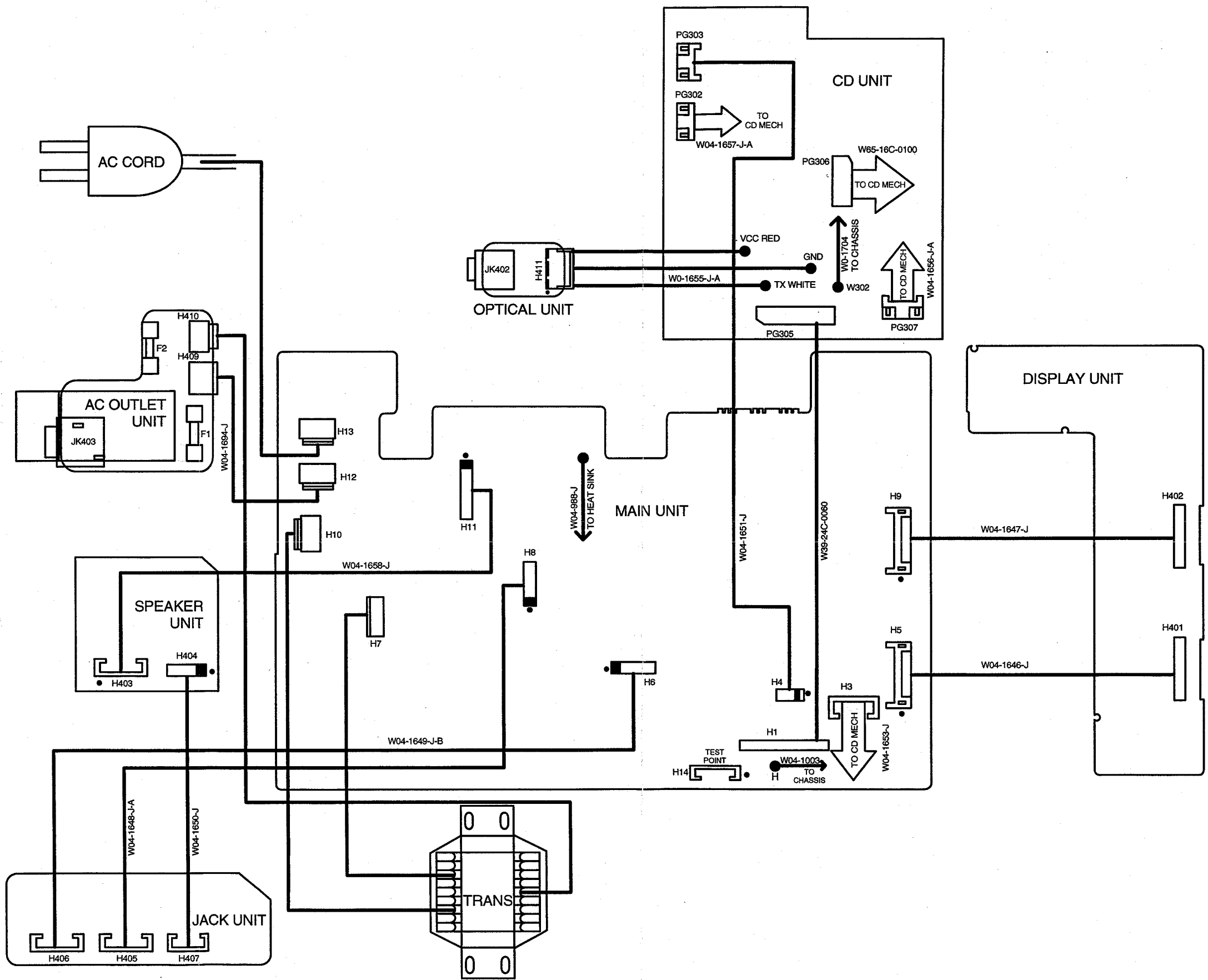



## PARTS LIST OF CD MECHANISM UNIT

Ref. No.	Part No.	Part Name	Remarks	Q'ty	Ref. No.	Part No.	Part Name	Remarks	Q'ty
1	948 0033 009	Chassis ass'y	450934256	1	118	948 0037 908	Screw	GSL20B2006	4
2	948 0033 106	Drawer 2	452643278	1	119	948 0038 004	Screw	GSL10B2006	4
3	948 0033 203	Holder L ass'y	450933241	1	120	948 0038 101	Washer	GWN31X120050	4
4	948 0033 300	Holder R3B ass'y	450933296	1	121	948 0038 208	Screw	GSL15A2608	7
11	948 0033 407	Drive gear ass'y	450934243	1	123	948 0038 305	Screw	GSP14A2604	4
12	948 0033 504	CRG 101 ass'y	450934347	1	127	948 0038 402	Screw	GST15A2005	1
18	948 0033 601	Bevel gear 4	452224214	1					
19	948 0033 708	Star gear ass'y	450934244	4					
23	948 0033 805	Cover 2	451123154	1					
24	948 0033 902	Shaft	453004173	1					
25	948 0034 008	Slider 4	452593175	1					
26	948 0034 105	Spline gear	452224021	1					
27	948 0034 202	Bevel gear 1	452224059	1					
28	948 0034 309	Gear idler 1	452224176	1					
29	948 0034 406	Olate spring	451604174	1					
30	948 0034 503	Bevel gear 3	452224177	1					
31	948 0034 600	Pulley C	452224058	1					
32	948 0034 707	Clamper SA ass'y	450934346	1					
33	948 0034 804	Slider arm R	452193187	1					
34	948 0034 901	Slider arm L	452193188	1					
35	948 0035 007	Slider 1	452592185	1					
36	948 0035 104	Slider 2 ass'y	450933240	1					
37	948 0035 201	Arm stopper A2	452394279	1					
38	948 0035 308	Arm stopper B	452394065	1					
39	948 0035 405	Gear idler A2	452224128	1					
40	948 0035 502	Gear idler C	452224051	1					
41	948 0035 609	Lever 2	452593289	1					
43	948 0035 706	Lifter	452593025	2					
47	948 0035 803	Pulley A	452294052	1					
48	948 0035 900	Motor CRG S ass'y	450934238	1					
49	948 0036 006	Motor DRW S ass'y	450934239	1					
50	948 0036 103	Spring	010804541	2					
51	948 0036 200	Spring	010824643	1					
52	948 0036 307	Spring	010824647	1					
53	948 0036 404	Belt	020834214	1					
54	948 0036 501	Belt	020834215	1					
56	948 0036 608	Cushion	450634136	2					
57	948 0036 705	Insulator	450633201	2					
58	948 0036 802	Insulator	450633202	2					
59	948 0036 909	Pick-up drive	DA11T3C	1					
62	948 0037 005	CRG 201 ass'y	450934348	1					
63	948 0037 102	CRG 301 ass'y	450934349	1					
68	948 0037 209	Spacer sw	452194127	1					
70	948 0037 306	PC board A ass'y	450934263	1					
71	948 0037 403	PC board B ass'y	450934265	1					
71A	948 0038 509	SWITCH	MPU10101MMB0	3					
72	948 0037 500	PC board C ass'y	450934264	1					
72A	948 0038 606	SWITCH	MPU20273BLB0	2					
75	—	Lead wire	450724171	1					
77	—	Lead wire	450724172	1					
85	948 0037 607	Rubber cushion	450634115	1					
113	948 0037 704	Washer	GWP15X045025S	2					
115	948 0037 801	Screw	GSL20A2606	8					

Ref. No.	Part No.	Part Name	Remarks	Ref. No.	Part No.	Part Name	Remarks
R359,360		Carbon chip 1.2 kohm 1/10W		C351,352		Ceramic chip 100pF/50V	
R361,362		Carbon chip 56 kohm 1/10W		C353,354		Ceramic chip 0.018μF/50V	
R363,364		Carbon chip 560 ohm 1/10W		C355		Electrolytic 22μF/16V	
R365,366		Carbon chip 620 ohm 1/10W		C356		Ceramic chip 560pF/50V	
R367,368		Carbon chip 3.3 kohm 1/10W		C357		Ceramic chip 0.033μF/50V	
R371		Carbon chip 47 kohm 1/10W		C360,361		Electrolytic 22μF/16V	
R375-378		Carbon chip 4.7 kohm 1/10W		C362,363		Ceramic chip 20pF/50V(NP0)	CC73CH1H200JT
R391		Carbon chip 1 kohm 1/10W		C364,365		Electrolytic 47μF/16V	
R392		Carbon chip 22 ohm 1/10W		C366-368	253 1180 921	Ceramic 0.001μF/50V	CK45B1H102KT
R393		Carbon chip 1 kohm 1/10W		C370	253 1180 921	Ceramic 0.001μF/50V	CK45B1H102KT
R395		Carbon chip 100 ohm 1/10W		C373		Electrolytic 47μF/50V	
<b>CAPACITORS GROUP</b>				C377		Ceramic chip 0.1μF/50V	
C302		Ceramic chip 0.1μF/50V		C379		Electrolytic 220μF/10V	
C307	256 1059 938	Metalized 0.33μF/50V	CF93A1H334JT(JL)	C380-382		Electrolytic 100μF/16V	
C308		Electrolytic 0.33μF/50V		C383,384		Ceramic chip 0.1μF/50V	
C309,310		Ceramic chip 0.022μF/50V		C385,386		Electrolytic 100μF/16V	
C311		Ceramic chip 390pF/50V		C387		Ceramic chip 0.1μF/50V	
C312		Electrolytic 100μF/16V		C388		Ceramic chip 0.022μF/50V	
C313		Electrolytic 1μF/50V		C389		Electrolytic 220μF/10V	
C314		Ceramic chip 100pF/50V		C390		Ceramic chip 0.022μF/50V	
C315		Ceramic chip 0.027μF/50V		C391		Ceramic chip 0.001μF/50V	
C316,317		Ceramic chip 0.001μF/50V		C392		Ceramic chip 0.1μF/50V	
C318		Ceramic chip 0.1μF/50V		C393-395		Ceramic chip 0.022μF/50V	
C319		Electrolytic 220μF/10V		C396		Electrolytic 220μF/10V	
C320		Ceramic chip 0.047μF/50V		C397		Ceramic chip 0.1μF/50V	
C321		Ceramic chip 10pF/50V		C398		Electrolytic 100μF/16V	
C322		Ceramic chip 100pF/50V					
C323		Ceramic chip 0.1μF/50V					
C324		Ceramic chip 0.033μF/50V					
C325		Ceramic chip 0.0047μF/50V					
C326,327		Capacitor 0.1μF/100V					
C328,329		Ceramic chip 680pF/50V					
C330		Capacitor 0.1μF/100V					
C331		Electrolytic 100μF/16V					
C332		Electrolytic 220μF/10V					
C333		Electrolytic 1μF/50V					
C334		Electrolytic 100μF/16V					
C335		Ceramic chip 0.01μF/50V					
C336		Electrolytic 100μF/16V					
C337,338		Ceramic chip 0.033μF/50V					
C339		Ceramic chip 0.22μF/50V					
C340		Ceramic chip 0.0022μF/50V					
C341		Ceramic chip 0.001μF/50V					
C342		Ceramic chip 0.1μF/50V					
C343		Ceramic chip 560pF/50V					
C344		Ceramic chip 0.01μF/50V					
C345		Electrolytic 100μF/16V					
C346		Ceramic chip 120pF/50V					
C347,348		Ceramic chip 0.0033μF/50V					
C349		Electrolytic 2.2μF/50V					
C350		Electrolytic 22μF/16V					

Ref. No.	Part No.	Part Name	Remarks	Q'ty
<b>OTHER PARTS GROUP</b>				
L101	951 0011 205	Inductor 10μH		1
PG302	205 0234 044	4P EH connector base(S)		1
PG303	205 0355 046	4P PH connector base(S)		1
PG305	951 0013 504	24P FFC connector base	IMSA-9604S-24F	1
PG306	951 0014 707	16P FFC connector base	IMSA-9610S-16B	1
PG307	205 0355 062	6P PH connector base(S)		1
X301	GP3 8002 050	Cristal 16.9344 MHz	for CD DSP	1
	461 1067 001	Spacer		2
	951 0051 304	3P connector cord	for H411 (OPT OUT)	1
	—	1P wire ass'y (3T LUG)		1

## PARTS LIST OF EXPLODED VIEW

Note: The symbols in the column "Remarks" indicate the following destinations.  
 E3: U.S.A. & Canada model EK: U.K. model  
 E2: Europe model E1: Asia model

Ref. No.	Part No.	Part Name	Remarks	Q'ty	Ref. No.	Part No.	Part Name	Remarks	Q'ty	
18	951 0048 702	Main board ass'y	for E2,EK	1	△	33	951 0033 607	AC cord	for EK	1
	951 0048 715	Main board ass'y	for E3		37	951 0049 701	PWB support (A)	M25-354-A	5	
	951 0048 731	Main board ass'y	for E1		38	951 0049 808	Bracket (R)	M02-1409	1	
		Main board			39	337 0082 001	3CD mechanism	DM40-1-086	1	
		Display board ass'y		1	40	951 0049 905	Bracket (L)	M02-1408	1	
28	951 0053 108	Ac outlet board	for E2,EK		41	951 0044 007	Top cover	M05-346-A	1	
28	951 0053 111	Ac outlet board	for E3		44	951 0050 004	Sponge sheet	P06-573	2	
28	951 0053 137	Ac outlet board	for E1		45	951 0050 101	Fibre washer	M27-304	2	
34	951 0053 205	Speaker board			46	951 0047 509	LED holder	M11-399A0B	1	
35	951 0053 302	Optical board			48	951 0011 001	Power trans sub(E2)	for E2,EK,E1	1	
36	951 0053 409	Jack board			48	233 6355 003	Power trans sub(E3)	for E3	1	
54	951 0049 109	Display board	@M50-D-BD		50	951 0050 208	PVC plate	A18-649-1	1	
75	951 0049 206	CD board ass'y	@M50-CD-BD	1	51	951 0016 307	Sensor holder	M11-393SAB	1	
		CD board			52	445 0056 008	Cord bush	M24-005	1	
1	144 2719 000	Front panel	DA14-1633-C	1	55	951 0051 401	Display BD plate	A18-658-A	1	
1	144 2719 013	Front panel	for E2,EK	1	56	951 0046 801	Power knob bracket	M02-1442A0I	1	
2	146 2202 005	Knob cap (A)	M38-112EAG	2	57	951 0047 101	Power knob ring	M17-089AAI	1	
3	951 0046 704	Disc knob	A21-939SAV	1	58	951 9002 053	Spring plate	M27-303	5	
4	951 0046 607	Eject knob	A21-938ABW	3	59	951 0050 305	Earth plate	A16-826	1	
5	146 2203 004	Knob cap (B)	M38-111EBG	5	60	412 2741 036	P.W.B holder	M25-363-KG	1	
6	112 0856 007	Volume knob ass'y		1	61	951 0050 402	Transformer MTG BKT	M02-1463	1	
7	143 1087 002	Window (CD)	DA05-511	1	62	951 0050 509	Plastic washer	M25-371	1	
8	143 1086 003	Remocon filter	A05-512A0C	1	63	951 0050 606	Safety cover	A18-663	1	
10	951 0046 908	Inner panel	M13-669SCV	1	63	951 0050 703	Safety cover	A18-66,U	1	
11	113 1888 006	Power knob ass'y		1			for EK,E2,E1			
13	951 0045 006	Side escutcheon (L)	M38-114EAG	1	69	GP3 8005 019	Soldering lug	M27-222	1	
14	951 0044 803	Loader panel	M05-347UAV	1	70	951 9002 040	Metal washer	M27-247-N	1	
15	951 0044 900	Side escutcheon (R)	M38-113EAG	1	71	951 9001 164	NUT	M12-040-N	1	
16	393 8049 004	VFD	DC44-38049004	1	72	461 1067 001	Spacer	G03-195-A	2	
			VFD401		73	951 0045 404	Insulation sheet	A18-634	1	
17	951 0047 004	Knob ring	M17-085SAV	1	74	951 0050 800	Shield plate	M37-198	1	
19	951 0049 303	PWB support (B)	M25-355	5	★	—	Troidal ferrite clamp	C52-013	1	
20	104 0317 008	Foot	M31-055A0B	4	★	951 0050 907	8pin wire ass'y (PH/EH)	W04-1653-J	1	
21	461 1066 002	Felt	G03-194	4			L=200mm			
22	—	Conductive tape	M37-199	2	★	951 0051 003	6pin wire ass'y (PH/PH)	W04-1656-J-A	1	
24	951 0045 200	Chassis	M02-1410-B	1			L=80mm			
25	—	Heat sink	G07-180	1	★	951 0051 100	4pin wire ass'y (EH/EH)	W04-1657-J-A	1	
26	951 0049 400	P.W.B. bracket	M02-1060	2			L=80mm			
29	951 0049 507	X'FMR bracket	M02-1411-A	1	★	951 0045 103	FFC cable 24pin	W39-24C-0060	1	
30	951 0044 706	Rear panel (E2)	M02-1412-A	1			L=60mm			
			for E2,EK,E1		★	951 0051 207	Laser pick label	P05-2735	1	
30	951 0044 719	Rear panel (E3)	for E3	1	★	951 0044 609	Rear label (E2/EK)	P05-2699	1	
△	31	233 6337 005	Power trans	1	★	951 0044 612	Rear label (E3)	P05-2700	1	
			DC23-BH1259A		★	951 0044 625	Rear label (E1)	P05-2701-A	1	
			for E2,EK,E1		★	513 1642 002	Serial label	P05-2773	1	
△	31	233 6336 006	Power trans	1						
			for E3							
32	951 0049 604	Frame transformer	M02-1413	1						
△	33	951 0009 709	AC cord	1						
			W04-1617							
			for E2,E1							
△	33	951 0028 201	AC cord	1						
			for E3							

Ref. No.	Part No.	Part Name	Remarks	Q'ty
<b>SCREWS</b>				
9	951 9001 070	Screw 3×6 CBTS(S)-Z	M19-088	3
12	GP3 8009 007	Screw 2.6×8 CBTS(P)-Z	M19-072W	14
23	473 7005 002	Screw 3×10 CBTS(S)-Z	M19-107	6
27	477 0263 018	3P. swelling screw	DM19-277-NI	2
42	473 7004 016	Screw 4×6 CBTS (S)-Z	M19-276	4
43	951 9001 180	Screw 3×8 CBTS(P)-B	M19-146W	14
47	951 9001 559	Screw 3×8 CBTS(S)-B	M19-265	4
49	951 9002 008	Screw 3×6 CBTS(S)-B	M19-271-BK	10
53	951 9001 193	Screw 3×14 CBTS(P)-Z	M19-259W	2
65	951 9002 105	Screw 3×12 CBTS(P)-Z	M19-016W	5
66	473 7015 018	Screw 3×8 CBTS(S)-B	M19-281-BK	2
67	951 9002 118	Screw 3×6 CBTS(P)-Z	M19-012W	2
68	GP3 8009 004	Screw 3×10 CBTS(P)-Z	M19-018W	4

EXPLODED VIEW

1 2 3 4 5 6 7 8

**WARNING:**  
Parts marked with this symbol  have critical characteristics. Use ONLY replacement parts recommended by the manufacturer.

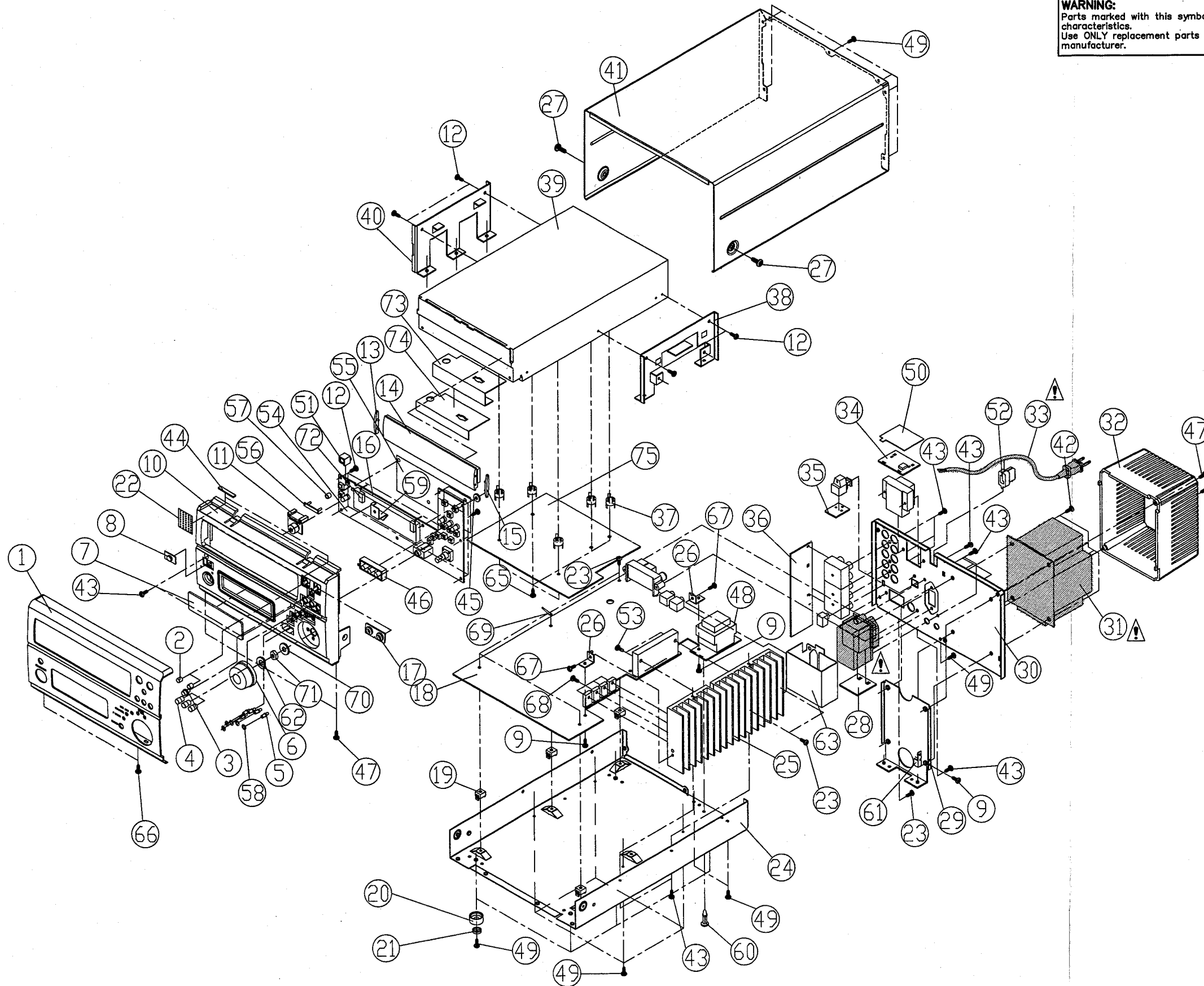

A  
B  
C  
D  
E

# EXPLODED VIEW OF CD MECHANISM UNIT

1                      2                      3                      4                      5                      6                      7                      8

A

B

C

D

E

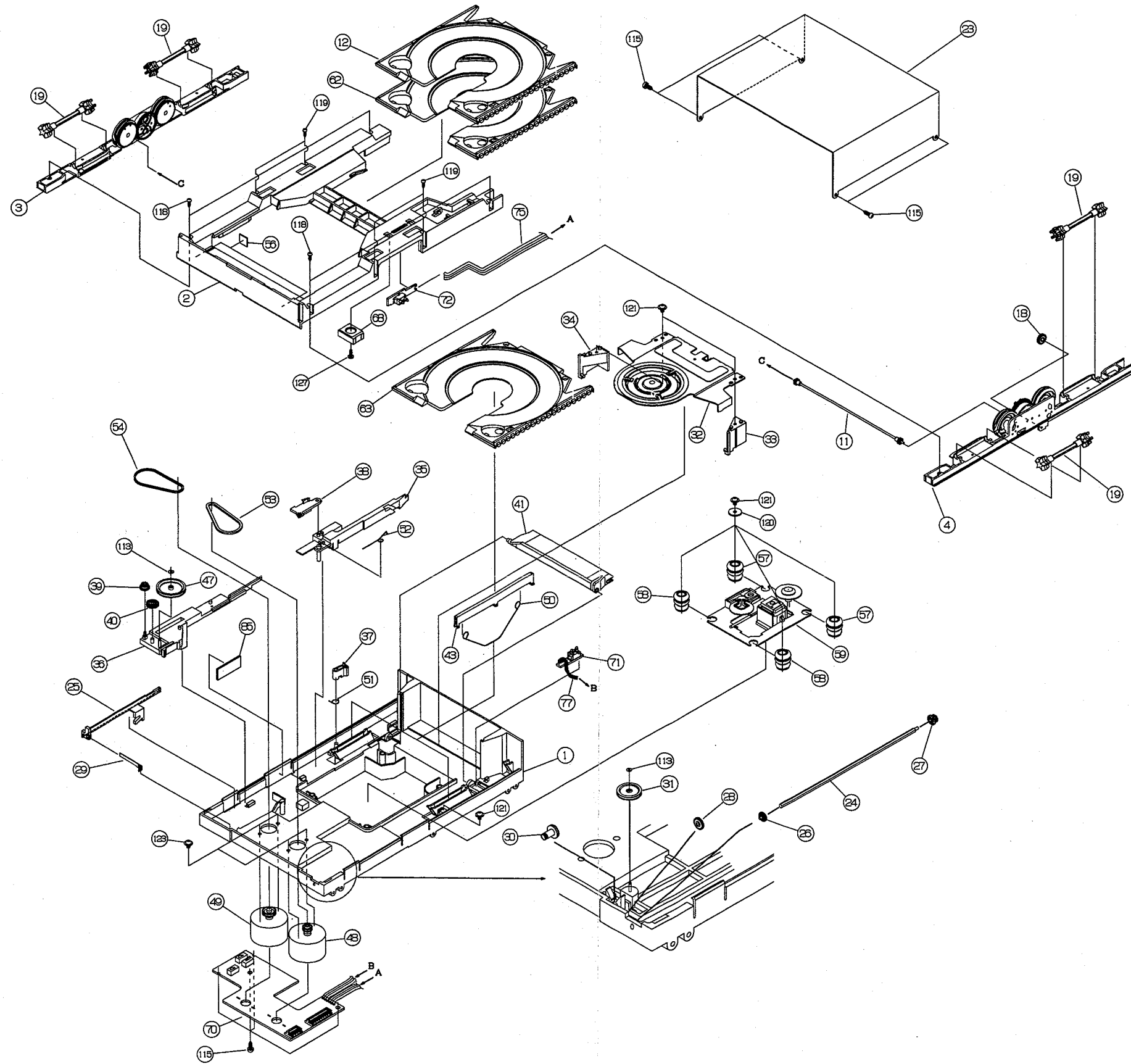



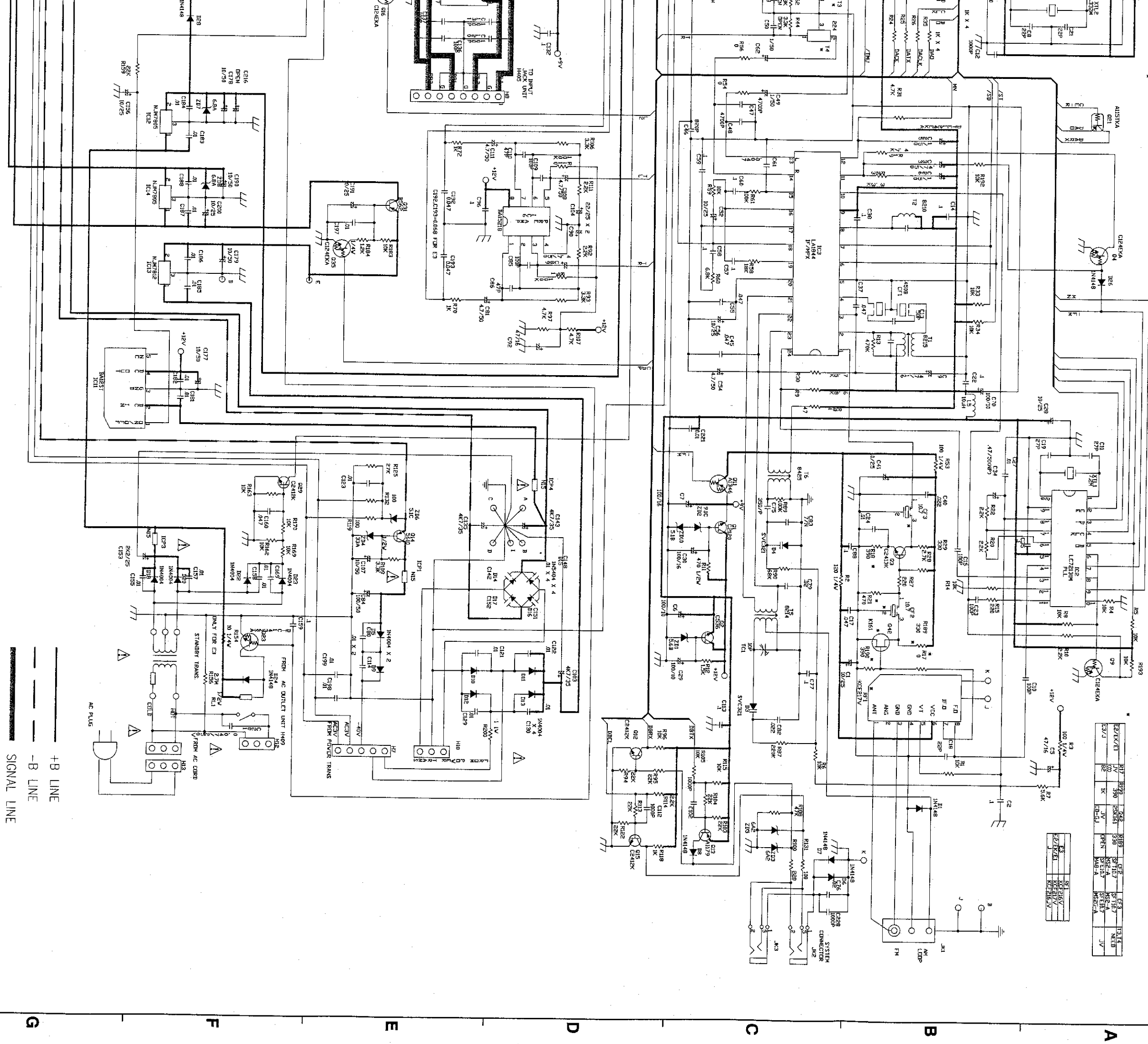

R17	B90	Q42	R183	152	423	131E
E2/E/E/31	JV	390	S8551	330	SF102	131E
E3/J	Q1	IK	390	SF102	SF102	131E
	Q2	IK	390	SF102	SF102	131E
	Q3	IK	390	SF102	SF102	131E
	Q4	IK	390	SF102	SF102	131E

——— +B LINE  
 - - - -B LINE  
 ——— SIGNAL LINE

SCHEMATIC DIAGRAMS (1/4)  
MAIN UNIT

SCHEMATIC DIAGRAMS (2/4)

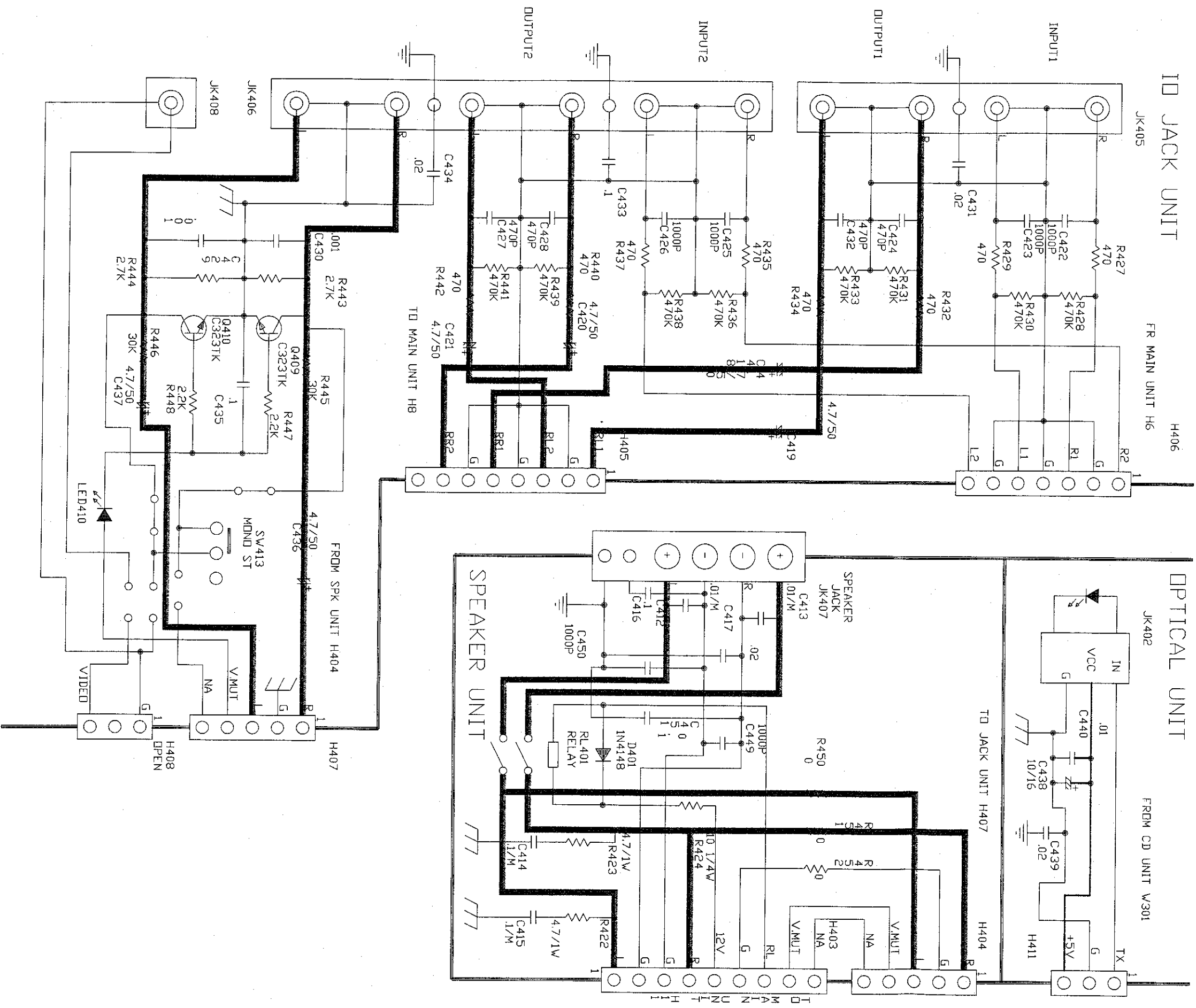

1 2 3 4 5 6



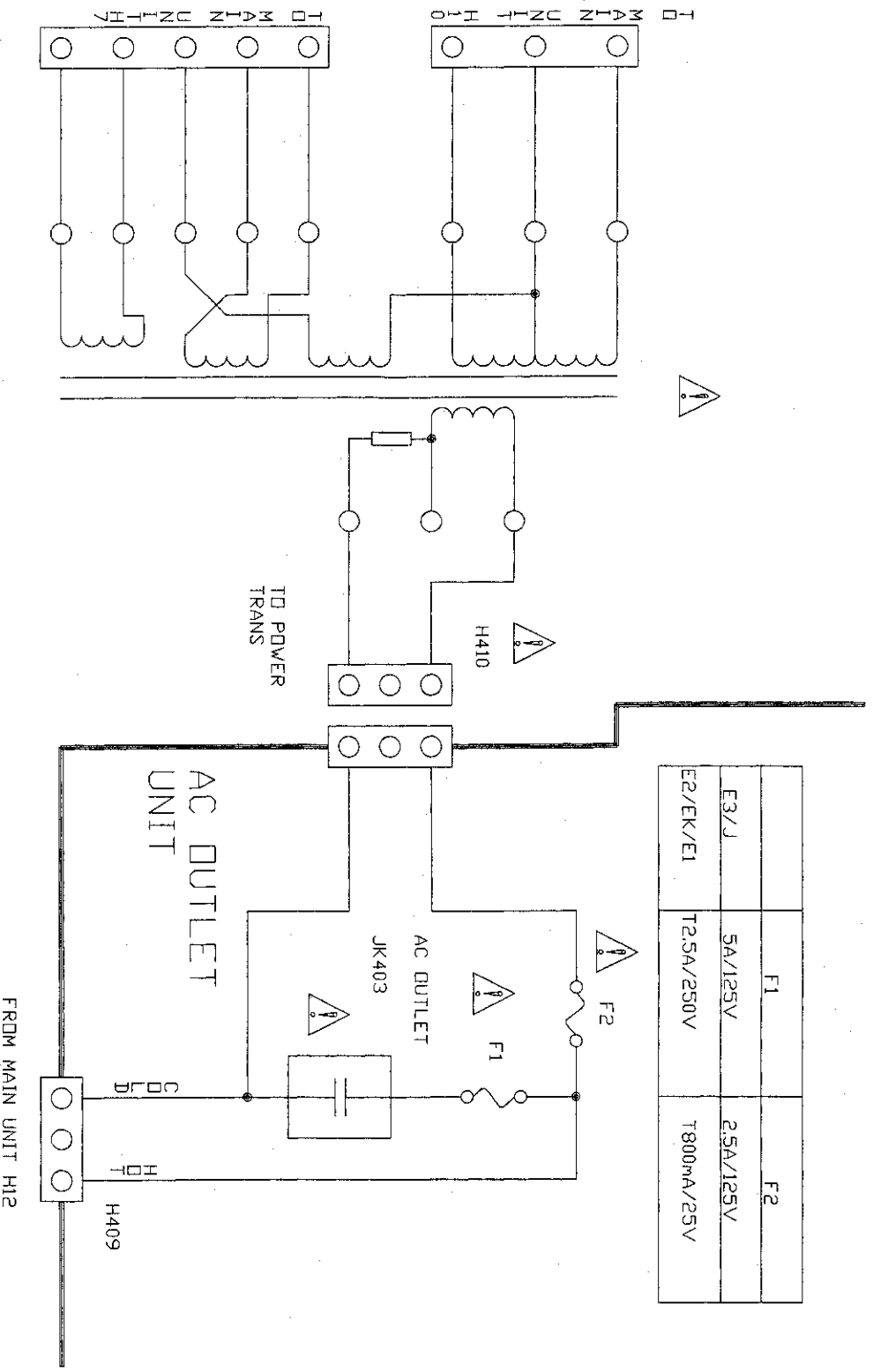

FERRITE CORE

POWER TRANS

**NOTICE**  
 ALL RESISTANCE VALUES IN OHM. K=1,000 OHM M=1,000,000 OHM  
 ALL CAPACITANCE VALUES IN MICRO FARAD. P=MICRO-MICRO FARAD  
 EACH VOLTAGE AND CURRENT ARE MEASURED AT NO SIGNAL INPUT  
 CONDITION.  
 CIRCUIT AND PARTS ARE SUBJECT TO CHANGE WITHOUT PRIOR  
 NOTICE.

**WARNING:**  
 Parts marked with this symbol  have critical characteristics.  
 Use ONLY replacement parts recommended by the manufacturer.

**CAUTION:**  
 Before returning the unit to the customer, make sure you make either (1) a leakage current check or (2) a line to chassis resistance check. If the leakage current exceeds 0.5 millamps, or if the resistance from chassis to either side of the power cord is less than 460 kohms, the unit is defective.

**WARNING:**  
 DO NOT return the unit to the customer until the problem is located and corrected.

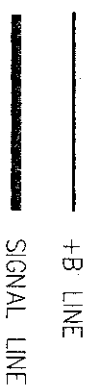

**SCHEMATIC DIAGRAMS (2/4)**  
 AC OUTLET UNIT  
 SPEAKER UNIT  
 OPTICAL UNIT  
 JACK UNIT



6

7

8

9

10

11

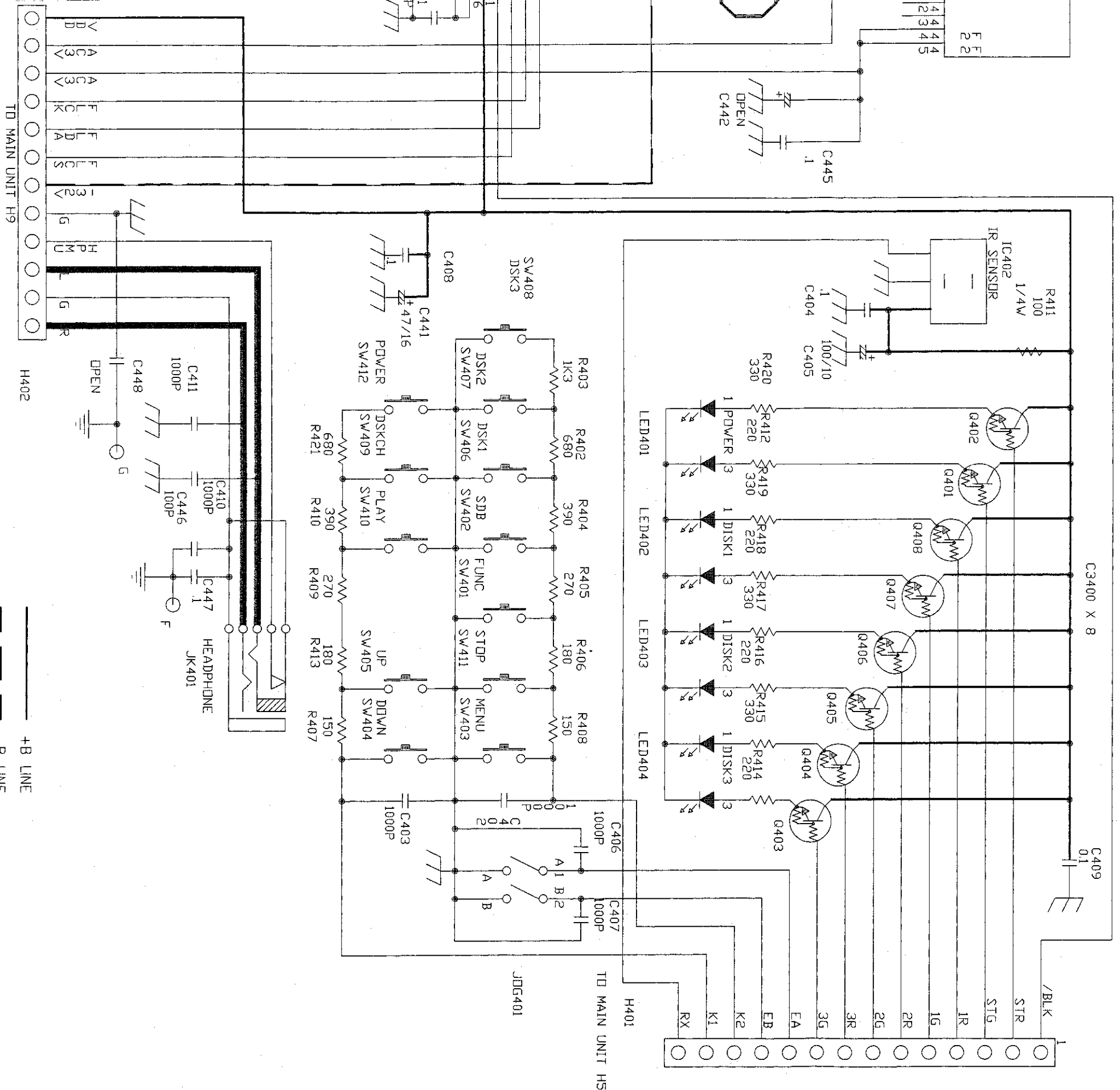

IN OHM, k=1,000 OHM, M=1,000,000 OHM  
 S IN MICRO FARAD, P=MICRO-MICRO FARAD  
 RESISTOR VALUES ARE MEASURED AT NO SIGNAL INPUT

SUBJECT TO CHANGE WITHOUT PRIOR

Symbol  $\Delta$  have critical characteristics.  
 parts recommended by the manufacturer.

to the customer, make sure you make either (1) a  
 (2) a line to chassis resistance check. If the leakage  
 amps, or if the resistance from chassis to either side  
 is than 450 kohms, the unit is defective.

to the customer until the problem is located and

SCHEMATIC DIAGRAMS (3/4)  
 DISPLAY UNIT

SCHEMATIC DIAGRAMS (4/4)

1 2 3 4 5 6

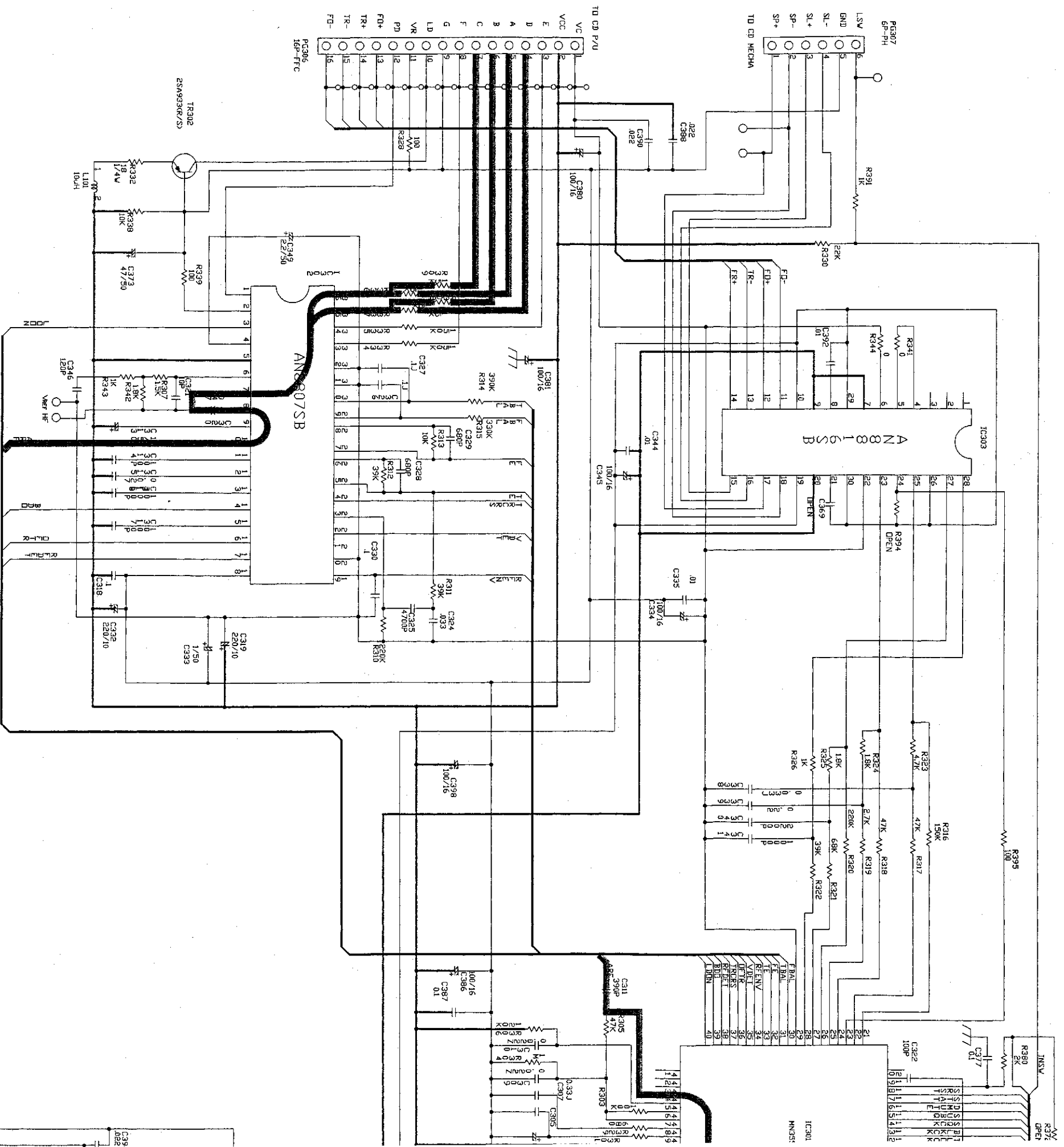

**NOTICE**  
 ALL RESISTANCE VALUES IN OHM, K=1,000 OHM M=1,000,000 OHM  
 ALL CAPACITANCE VALUES IN MICRO FARAD. P=MICRO-MICRO FARAD  
 EACH VOLTAGE AND CURRENT ARE MEASURED AT NO SIGNAL INPUT  
 CONDITION.  
 CIRCUIT AND PARTS ARE SUBJECT TO CHANGE WITHOUT PRIOR  
 NOTICE.

**WARNING:**  
 Parts marked with this symbol  use ONLY replacement parts recomm.  
**CAUTION:**  
 Before returning the unit to the custi-  
 leakage current check or (2) a line t  
 current exceeds 0.5 milliamperes, or if t  
 of the power cord is less than 460 k  
**WARNING:**  
 DO NOT return the unit to the custor  
 corrected.



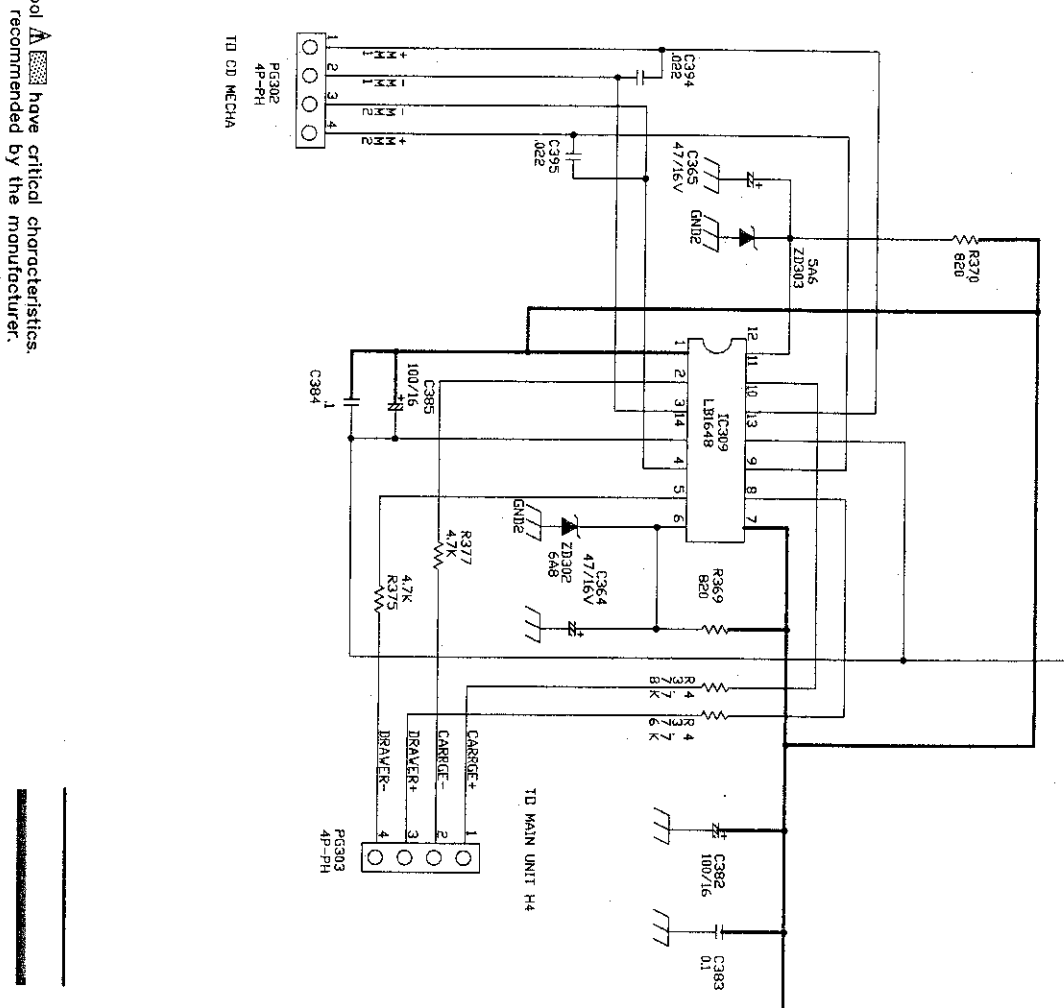
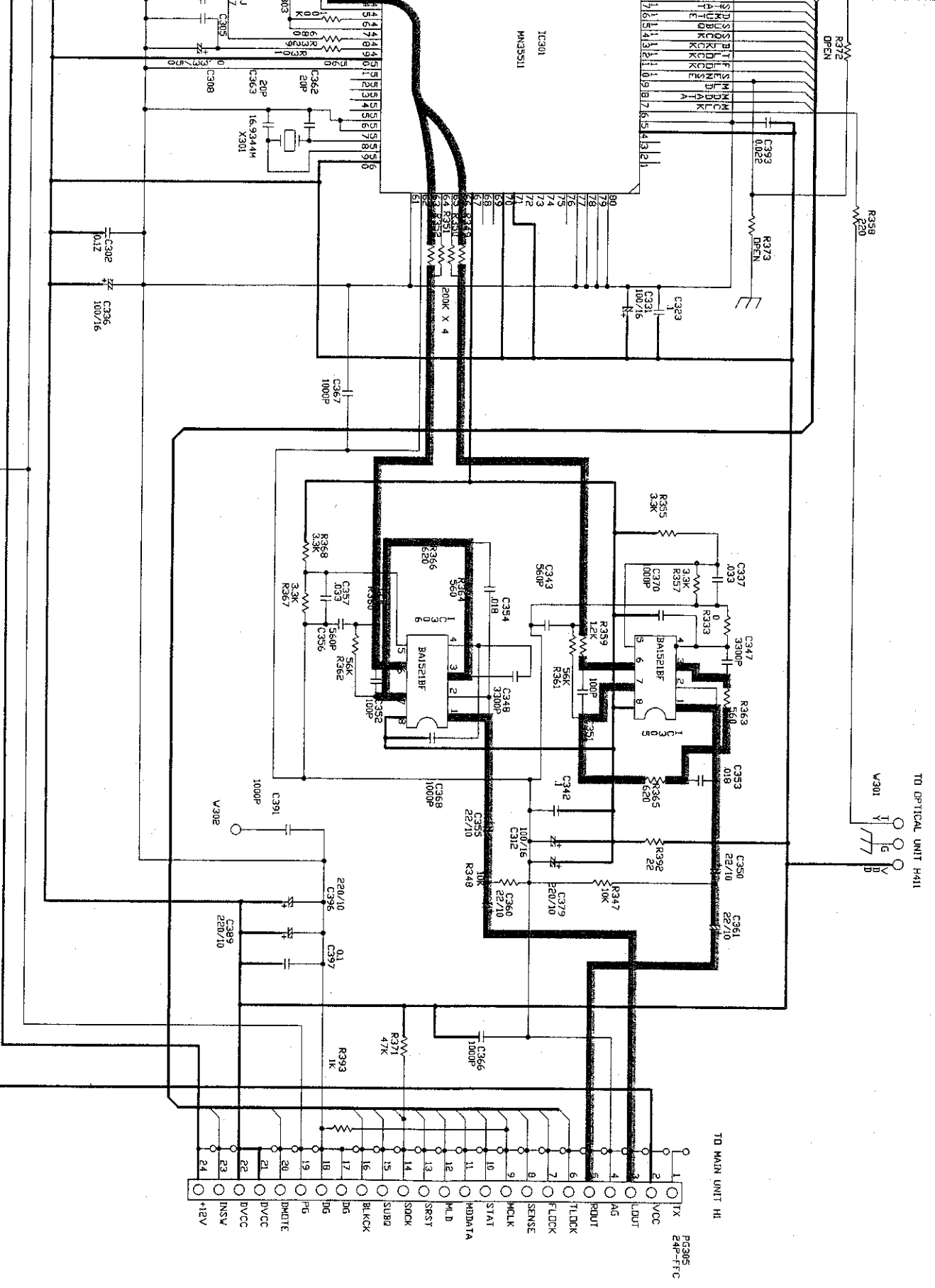

— +B LINE  
 — SIGNAL LINE

of A have critical characteristics. recommended by the manufacturer.  
 the customer, make sure you make either (1) a line to chassis resistance check. If the leakage is, or if the resistance from chassis to either side on 460 kohms, the unit is defective.  
 the customer until the problem is located and

SCHEMATIC DIAGRAMS (4/4)  
 CD UNIT

## PACKING VIEW

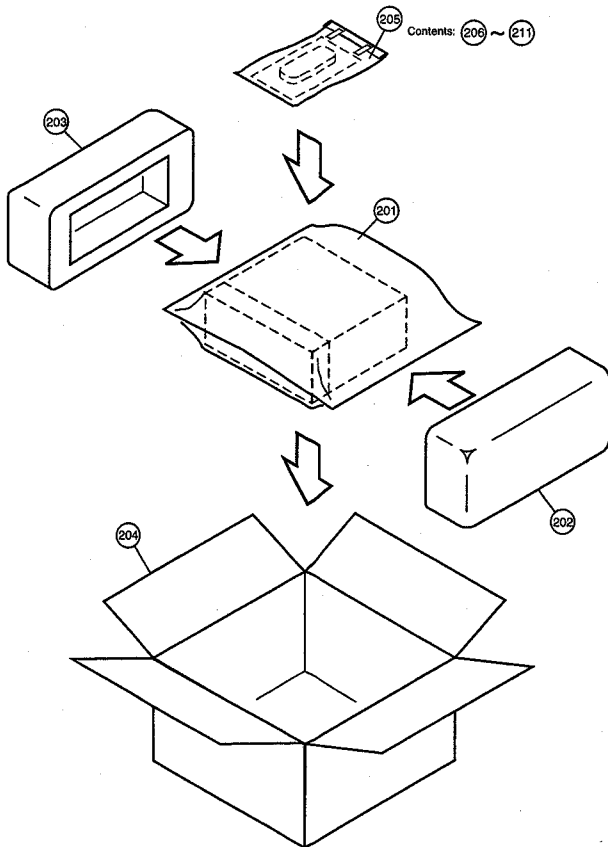

## PARTS LIST OF PACKING & ACCESSORIES

Note: The symbols in the column "Remarks" indicate the following destinations.  
 E3: U.S.A. & Canada model      EK: U.K. model  
 E2: Europe model                      E1: Asia model

Ref. No.	Part No.	Part Name	Remarks	Q'ty
201	951 0044 502	P.E bag	K04-253	1
202	503 1363 009	Cushion	K05-659-A-LL	1
203	503 1364 009	Cushion	K05-660-A-LL	1
204	501 2101 002	Carton case	K01-1849-002B for E2,E3,EK	1
204	501 2129 013	Carton case	for E1	1
205	951 0028 706	Polybag	K04-080WR(H)	1
206	951 0044 201	AM ant loop ass'y	@C50-009-SEMIA	1
207	951 0044 308	Remote handset ass'y	@M50-TX	1
208	—	Battery (R03,AAA)	B01-004-T-1	2
209	515 0867 101	S.S list	DP08-322-G	1
210	511 3647 009	Instruction manual	P02-590L8	1
211	951 0009 301	FM antenna ass'y	W04-1042-1	1
★	951 0044 405	Transport clamber	A18-667	1
★	511 3647 009	Instruction sheet	P05-2796 for E2,EK	1
★	511 3648 008	Instruction sheet	for E3	1
★	511 3646 000	Instruction sheet	for E1	1
★	—	Control card	DP05-2672	1
★	—	POS label E2	P05-2671 for E2	1
★	—	POS label EK	for EK	2
★	—	UPC LABEL	for E3	1

Be sure to remove the transport clamber before turning on the power.

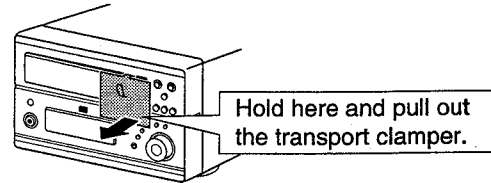

Be sure to keep the transport clamber after removing it, and reattach it as described below whenever transporting the UD-M50 in the future.

① Pass through the hole in the disc holder.

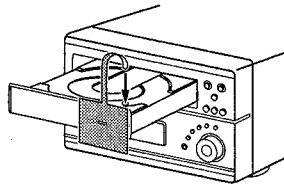

② Pass through the hole and fasten the transport clamber to the disc holder.

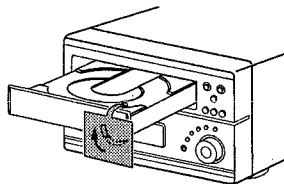

③ Unplug the UD-M50's AC cord and turn off the power.

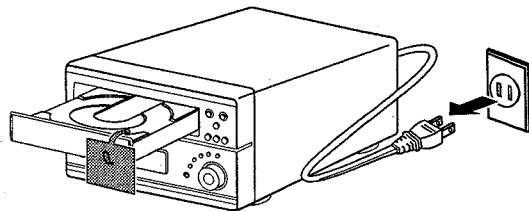

④ Close the disc holder by hand.

