

DENON

Hi-Fi Personal Component System

SERVICE MANUAL MODEL UD-M30 STEREO CD RECEIVER

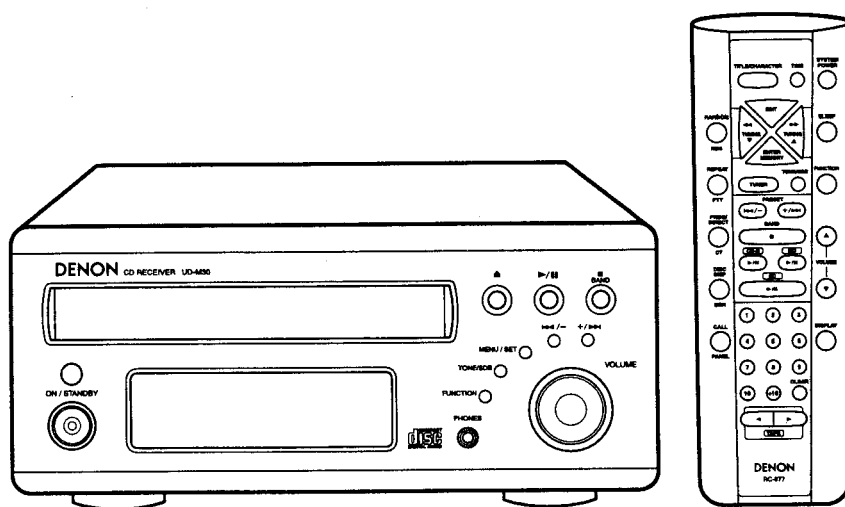

— TABLE OF CONTENTS —

SPECIFICATIONS	2
DISASSEMBLY	3,4
BLOCK DIAGRAM	5
ADJUSTMENT	6-9
SEMICONDUCTORS	10-15
PRINTED WIRING BOARD	16,17
NOTE FOR PARTS LIST	18
PARTS LIST OF P.W.B. UNIT ASS'Y	18-23
PARTS LIST OF EXPLODED VIEW	24
EXPLODED VIEW	25
EXPLODED VIEW OF CD MECHANISM UNIT	26
PARTS LIST OF MECHANISM UNIT	26
PACKING VIEW	27
PARTS LIST OF PACKING & ACCESSORIES	27
SCHEMATIC DIAGRAM	29,30

• Some illustrations using in this service manual are slightly different from the actual set.

NIPPON COLUMBIA CO., LTD.

SAFETY PRECAUTIONS

The following check should be performed for the continued protection of the customer and service technician.

LEAKAGE CURRENT CHECK

Before returning the unit to the customer, make sure you make either (1) a leakage current check or (2) a line to chassis resistance check. If the leakage current exceeds 0.5 milliamps, or if the resistance from chassis to either side of the power cord is less than 460 kohms, the unit is defective.

SPECIFICATIONS

RECEIVER SECTION

Reception frequency band:	FM: 87.5 MHz - 108.0 MHz AM: 520 kHz - 1710 kHz (U.S.A. & Canada model) 522 kHz - 1611 kHz (Europe & Asia model)
Reception sensitivity:	FM: 1.5 μ V/75 Ω /ohms AM: 20 μ V
FM stereo separation:	35 dB (1 kHz)
Rated output power:	20 W + 20 W (6 Ω /ohms, 1 kHz, T.H.D. 10 %)
Audio input/output jacks:	LINE1 input/output jacks, LINE2 input/output jacks, PRE OUT (with STEREO/MONO selector switch) jack, 3.5 mm headphones jack

CD PLAYER SECTION

Wow & flutter:	Below measurable limits (± 0.001 % W.peak)
Sampling frequency:	44.1 kHz
Optical source:	Semiconductor

CLOCK, TIMER SECTION

Clock system:	Power source synchronous system Everyday timer (1 setting) Once timer (1 setting) Sleep timer (maximum 60 min.)
---------------	--

GENERAL

Power supply:	AC 120 V, 60 Hz (U.S.A. & Canada model) AC 230 V, 50 Hz (Europe & Asia model)
Power consumption:	50 W
Maximum external dimensions:	210 (W) \times 95 (H) \times 325 (D) mm (8-17/64" \times 3-45/64" \times 12-13/16") (including feet, controls and terminals)
Mass:	3.8 kg (8 lbs. 6 oz)

REMOTE CONTROL UNIT (RC-877)

Remote control system:	Infrared pulse
Number of buttons:	39
Power Supply:	Two DC 1.5 V R03/AAA batteries
Maximum external dimensions:	61 (W) \times 188 (H) \times 26 (D) mm (2-13/32" \times 7-13/32" \times 1-1/32")
Mass:	120 g (4.2 oz) (including batteries)

* Maximum dimensions include controls, jacks, and covers.
(W) = Width, (H) = Height, (D) = Depth

* For improvement purposes, specifications and functions are subject to change without advanced notice.

● TRANSISTORS

2SB562T

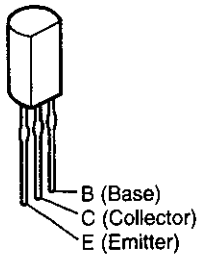

DTC114ES
DTC143ZS

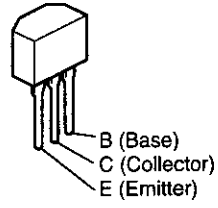

DTA114TK
DTA114EK
DTA115TK
DTC114TK
DTC114EK
DTC144EK
DTC323TK

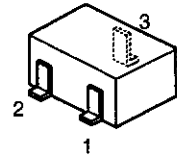

PNP Type

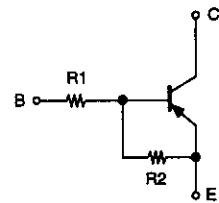

NPN Type

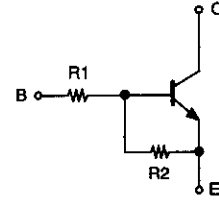

	R1	R2
DTA114EK	10kΩ	10kΩ
DTA114TK	10kΩ	—
DTA115TK	100kΩ	—

	R1	R2
DTC144EK	47kΩ	47kΩ
DTC323TK	2.2kΩ	—
DTC114EK	10kΩ	10kΩ
DTC114TK	10kΩ	—
DTC143ZS	4.7kΩ	47kΩ
DTC114ES	10kΩ	10kΩ

2SA933 (S)

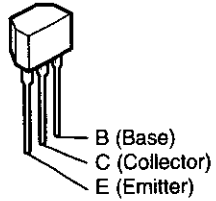

2SA1037K
2SC2412K (S/R)
2SC3326 (A/B)

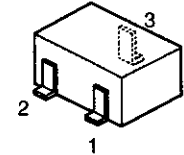

● DIODES (LED Included)

1N4148

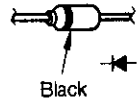

1N4004

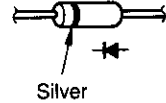

MTZ-J12AT
MTZ-J33CT
MTZ-J5.6A
MTZ-J6.2A

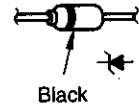

D3SBA60

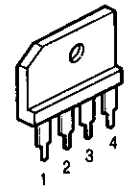

SLR-9336DS-91

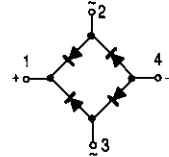
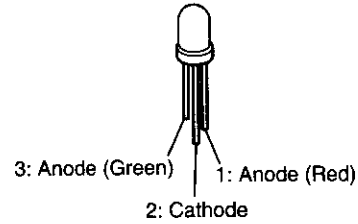

● REMOTE CONTROL SENSOR

RPM6938-SV4 (IR701)

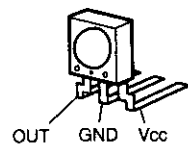

● OPTICAL OUTPUT TERMINAL

TOTX178A (IC601)

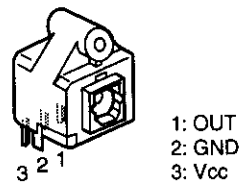

● FL DISPLAY

11-BT-182GNK (FL601)

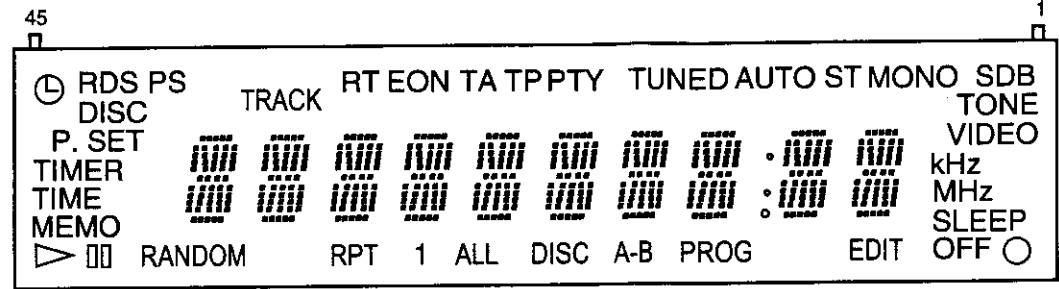

Pin Assignment

Pin No.	4	4	4	4	4	3	3	3	3	3	3	3	3	3	2	2	2	2	2	2	2	2	2	1	1	1	1	1	1	1	1	1	1	8	7	6	5	4	3	2	1		
Connection	F	F	N	N	1	2	3	4	5	6	7	8	9	0	1	N	2	2	2	2	2	1	1	1	1	1	1	1	1	1	1	1	1	0	9	8	7	6	5	4	3	2	1

- 1) F1, F2..... Filament
- 2) NP..... No Pin
- 3) NC..... No connection (NC pin should be electrically open on the PC board)
- 4) DL..... Datum Line
- 5) 1G-11G..... Grid
- 6) Field of vision is a minimum of 39° from the upper side, 30° from the lower side.

PRINTED WIRING BOARDS

1 2 3 4 5 6 7 8

UD UNIT

A

B

C

D

E

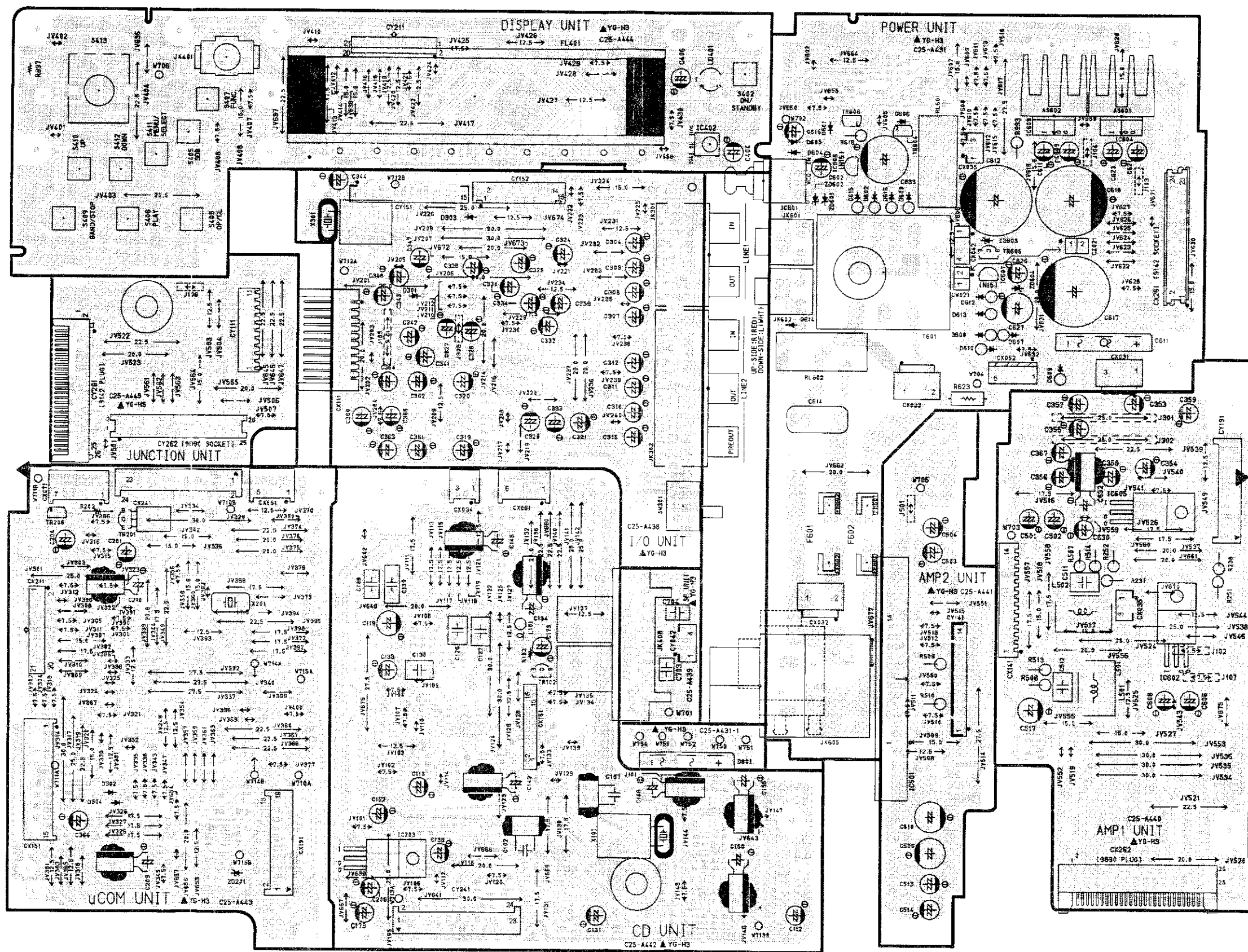

COMPONENT SIDE

DISASSEMBLY

(Follow the procedure below in reverse order when reassembling)

Top Cover

1. Remove 2 screws ① on both sides.
2. Remove 5 screws ② on the rear.
3. Detach the Top Cover to the arrow direction.

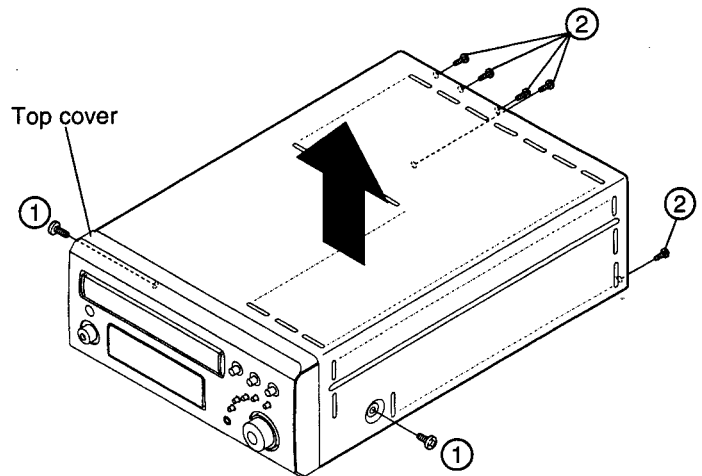

Front Panel

1. Disconnect FFC on the rear of the CD Mecha.
2. Remove 1 screw ③ fixing the wire on the radiator.
3. Remove 4 lower screws ④.
4. Detach the Front Panel with releasing the hooks on both sides.

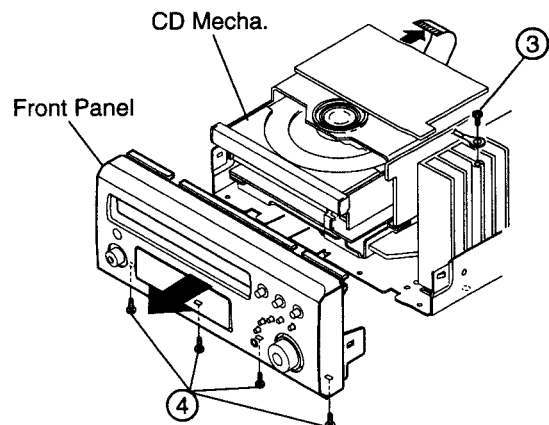

CD Mecha.

1. Disconnect FFC coming from the top of the CD Mecha.
2. Unplug the connector on the rear of the μ com PWB.
3. Remove 4 screws ⑤ on the μ com PWB.
4. Fully pull out the loader by turning the gear under the loader of the CD Mecha.
5. Remove 4 screws ⑥ to detach the CD Mecha.

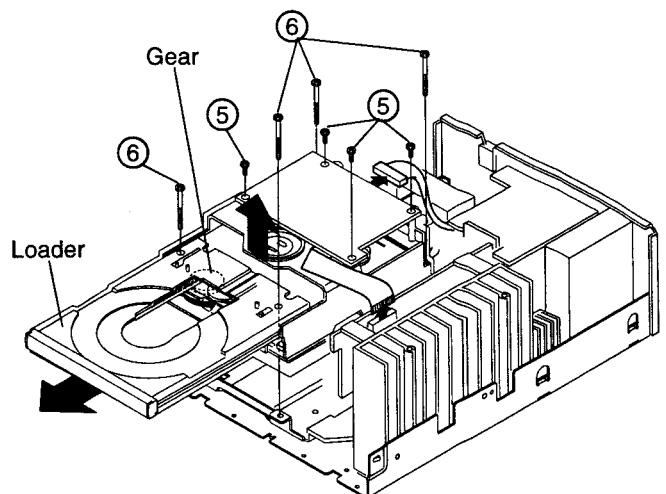

Rear Panel

1. Pull out the cord bush.
2. Remove 12 screws (7).

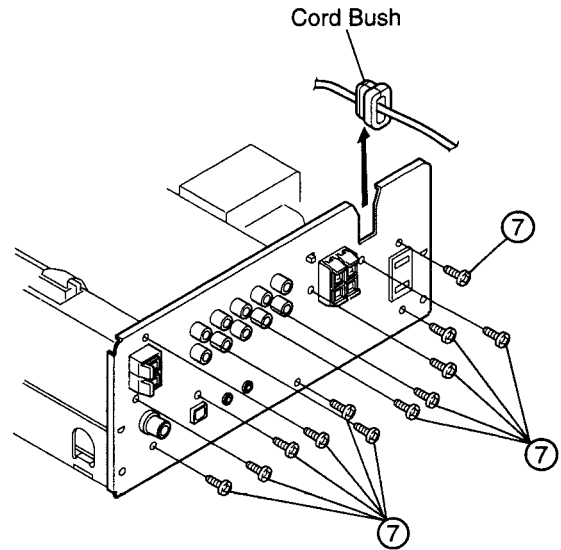

Main PWB

1. Remove 4 screws (8) fixing the radiator under the chassis.
2. Unplug 4 connectors on the Main PWB.
3. Remove 5 screws (9).
4. Detach the Main PWB together with the radiator and Power PWB.

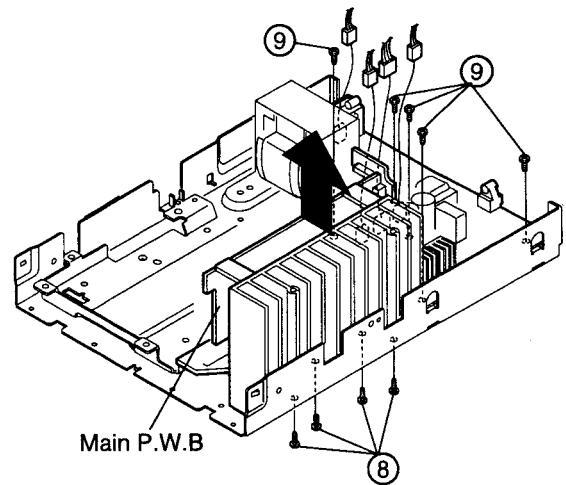

Display PWB

1. Pull out the VR knob.
2. Remove the VR nut (10).
3. Remove 9 screws (11).

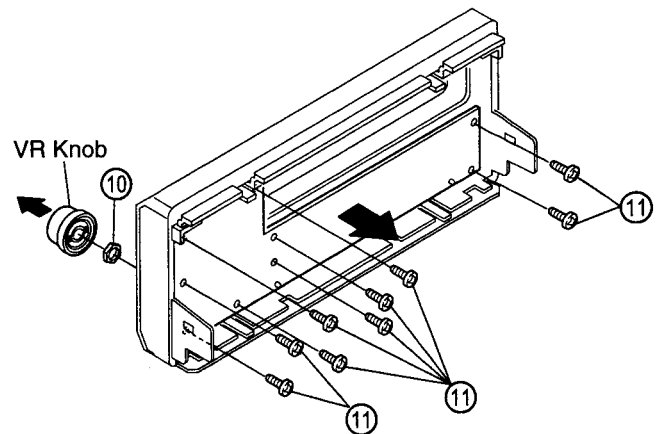

BLOCK DIAGRAM

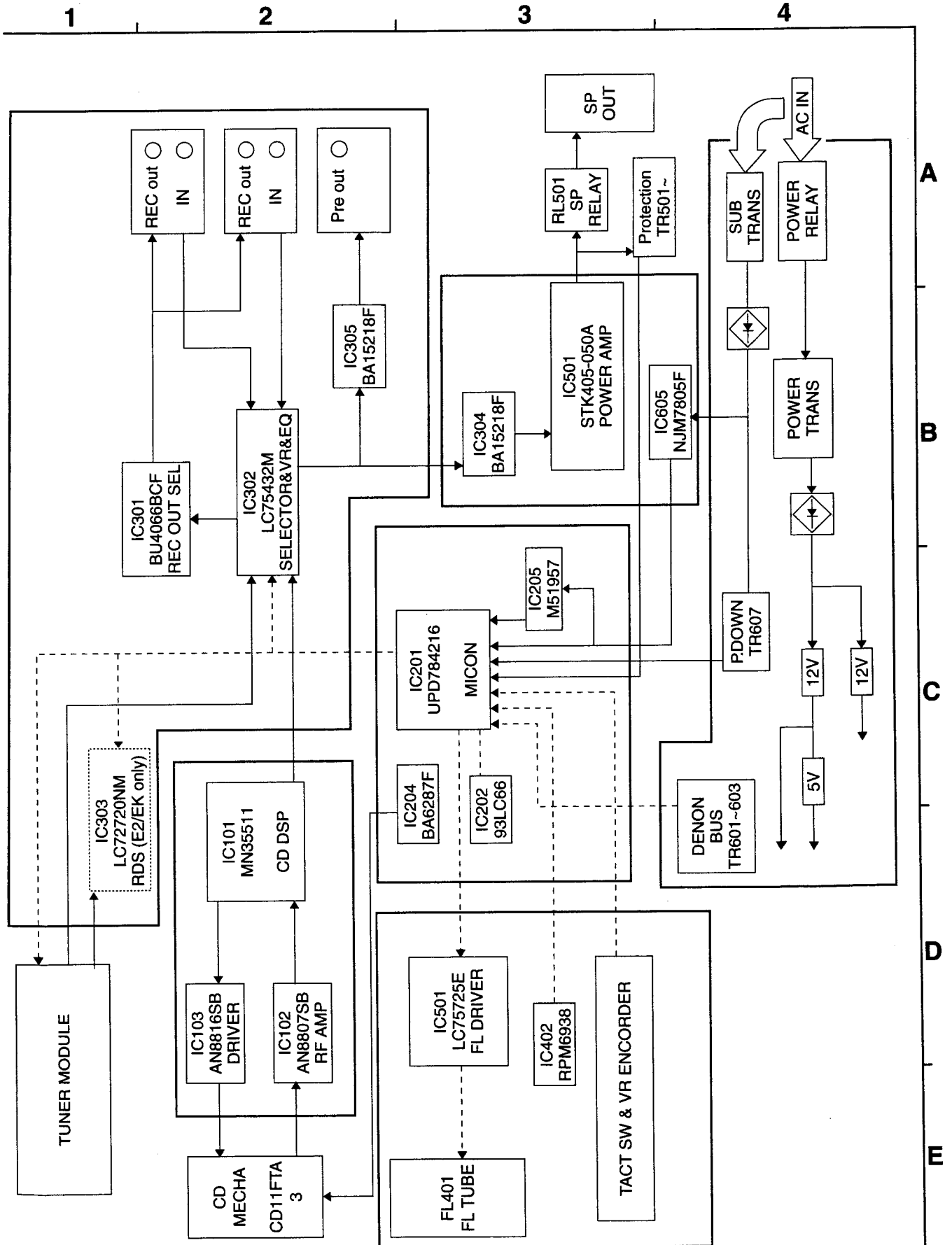

CONFIRMING THE SERVO

A microcomputer adopted in this unit has the service programs so that each servo adjustment can be performed easily by the operating buttons.

This unit which adopted digital servo has the ability to automatically adjust Focus Gain, Focus Balance, Focus Offset, Tracking Gain, Tracking Balance, and Tracking Offset.

1. Actuating the Service Program

Plug the AC cord while pressing the Power and Function keys.

(Service program actuates and displays track number 0 1.)

Note: The operating button do not function when service program actuates.

2. Operating Function at Service Program Actuation

Button Operation	Function	Description																					
OPEN/CLOSE ▲	Opens or closes the disc holder.	<ul style="list-style-type: none"> • Opens or closes when disc is stopped. • Operates other keys after open or close. 																					
STOP ■	Stops system operation.	<ul style="list-style-type: none"> • Displays track number 0 1. • Press when adjustment completed or correcting it. 																					
PLAY ▶	Operates the Focus servo and turns disc.	<ul style="list-style-type: none"> • Displays track number 0 2 when operation is completed. 																					
◀▶	Performs Focus servo, Tracking servo, Slide servo, Spindle servo and various automatically adjustment.	<ul style="list-style-type: none"> • Performs Tracking servo and Slide servo when pressing PLAY button. • Displays track number 0 3 when operation is completed. • When unusualness is existed, displays index number (error message). But E 9, E - not error message. 																					
▶▶	Displays automatically adjustment effect of FG, FEXP, FBAL, FOFS, TG, TEXP, TBAL and TOFS.	<ul style="list-style-type: none"> • Press ■ button when ◀▶ button operation is completed. • When pressing ▶▶ button every once, displays automatically adjusting value about FG, FBAL, FOFS, TG, TBAL, and TOFS in the sequence. • Displays following indication: <table style="margin-left: auto; margin-right: auto;"> <thead> <tr> <th></th> <th>INDEX</th> <th>TIME</th> </tr> </thead> <tbody> <tr> <td>FG</td> <td>0 1</td> <td>XXmXXs</td> </tr> <tr> <td>FBAL</td> <td>0 2</td> <td>XXmXXs</td> </tr> <tr> <td>FOFS</td> <td>0 3</td> <td>XXmXXs</td> </tr> <tr> <td>TG</td> <td>0 4</td> <td>XXmXXs</td> </tr> <tr> <td>TBAL</td> <td>0 5</td> <td>XXmXXs</td> </tr> <tr> <td>TOFS</td> <td>0 6</td> <td>XXmXXs</td> </tr> </tbody> </table>		INDEX	TIME	FG	0 1	XXmXXs	FBAL	0 2	XXmXXs	FOFS	0 3	XXmXXs	TG	0 4	XXmXXs	TBAL	0 5	XXmXXs	TOFS	0 6	XXmXXs
	INDEX	TIME																					
FG	0 1	XXmXXs																					
FBAL	0 2	XXmXXs																					
FOFS	0 3	XXmXXs																					
TG	0 4	XXmXXs																					
TBAL	0 5	XXmXXs																					
TOFS	0 6	XXmXXs																					
Other Buttons	No normal operation.	<ul style="list-style-type: none"> • Do not operate other button except above. • When an error occurs, immediately turn power switch OFF. 																					

Note: Do not use remote control during service program operation.

3. Confirming Method

- (1) Required Measuring Equipments for adjustment
 1. Dual-trace oscilloscope
 2. Adjustment disc TCD-784 (ABEX)
- (2) Adjustment location

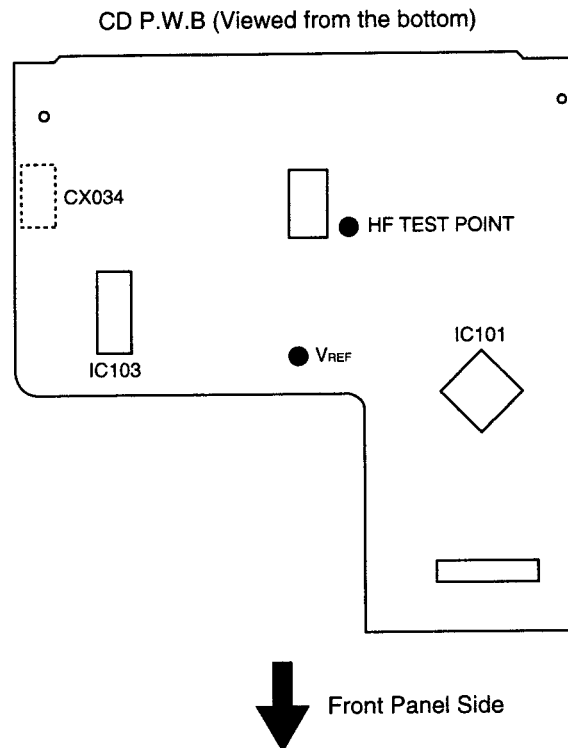

- (3) Confirming procedure
 1. Actuate service program.
 2. Load adjustment disc TCD-784.
 3. Press **▶** to indicate track number **02**.
 4. Press **◀◀** to indicate track number **03**.
 5. Press **■** button.
 6. When pressing **▶▶** button every once, confirm automatically adjusting values about FG, FBAL, FOFS, TG, TBAL and TOFS (refer to table 1 for the limits of value).
 7. When service program is completed, return to normal mode (turn power switch ON).
 8. Confirm HF level.
- (4) Pickup current measurement
 1. Press **▶** to indicate track number **02**.
 2. Press **◀◀** to indicate track number **03**.
 3. Measure the voltage between 1 pin and 3 pin of CX034, and confirm that the value is 1.4 V or less (normally 0.9 V or around).

- (5) Confirm automatically adjustment values about FG, FBAL, FOFS, TG, TBAL and TOFS.
1. Press ► button, displays track number 02.
 2. Press ◀◀ button, displays track number 03.
 3. Press ■ button, displays track number 01.
 4. Press ►► button, displays FG (Focus Gain Tentative) value, confirm the value within the limits of table 1.
 5. Press ►► button, displays FBAL (Focus balance) value, confirm the value within the limits of table 1.
 6. Press ►► button, displays FOFS (Focus offset) value, confirm the value within the limits of table 1.
 7. Press ►► button, displays TG (Tracking Gain) value, confirm the value within the limits of table 1.
 8. Press ►► button, displays TBAL (Tracking Balance) value, confirm the value within the limits of table 1.
 9. Press ►► button, displays TOFS (Tracking Offset) value, confirm the value within the limits of table 1.

Confirming Table about Digital Servo Adjusting Value (table 1)

	TRACK INDEX	XXMXXS
FG	01 <u>01</u>	M42s~1M00s
FBAL	01 <u>02</u>	-1M25s~1M25s
FOFS	01 <u>03</u>	-M35s~M35s
TG	01 <u>04</u>	M51s~1M56s
TBAL	01 <u>05</u>	-58s~1M04s
TOFS	01 <u>06</u>	-M15s~M15s

(6) HF level Confirming

Oscilloscope		Check	Step
<p>Connection</p>			
V	H	<p>A=0.40~0.85V</p> <p>Eye Pattern</p> <p>Eye Pattern</p>	<ol style="list-style-type: none"> 1. Press button. 2. Check HF level with oscilloscope. 3. Confirm that the waveform is in good shape. (◇ eye pattern in center must be able to discriminate clearly.)
50mV/div or 20mV/div	0.2μs/div or 0.5μs/div		
<ul style="list-style-type: none"> • Set input mode to ALTERNATE or CHOPPER. 			

SEMICONDUCTORS

● IC's

μPD784216AGC-109-8EU (IC201)

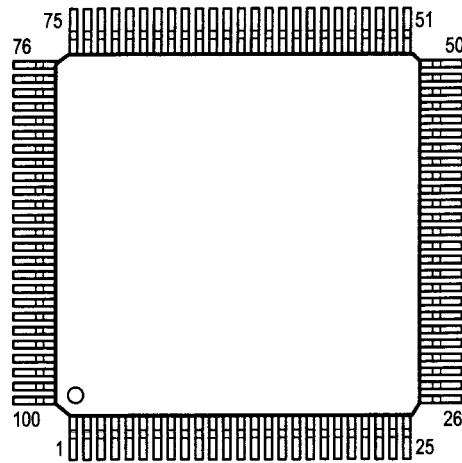

μPD784216AGC-109-8EU Terminal Function

Pin. No.	Name	Symbol	I/O	Function
1	P120/RTP0	ENC A	I	Rotary encoder INPUT A
2	P121/RTP1	ENC B	I	Rotary encoder INPUT B
3	P122/RTP2	V.MUTE	O	Volume mute output, mute: Low
4	P123/RTP3	/POWER	O	Amp circuit power ON/OFF output, ON: High
5	P124/RTP4	/RMUTE	O	Speaker Relay ON/OFF output, ON: High
6	P125/RTP5	N.C	O	
7	P126/RTP6	SEL. EEPROM	O	EEPROM chip enable output
8	P127/RTP7	FLCE	O	Chip select output to FL tube controller
9	VDD	VDD	—	Positive power: +5V
10	X2	X2	—	X'tal connection for main clock oscillation
11	X1	X1	I	X'tal connection for main clock oscillation
12	Vss	Vss	—	GND potential
13	XT2	XT2	—	X'tal connection for main sub-clock oscillation, not used
14	XT1	XT1	I	X'tal connection for main sub-clock oscillation, not used: Connect to Vss or Vcc
15	/RESET	/RESET	I	Micro-computer reset input
16	P00/INTP0	REMOCON	I	Remote-control receive data input
17	P01/INTP1	50/60	I	50/60Hz AC input
18	P02/INTP2/NMI	/DB RXD	I	DENON BUS Data input (interrupt input)
19	P03/INTP3	PROTECT	I	Speaker Terminal DC voltage detect signal input L: protect
20	P04/INTP4	N.C	O	
21	P05/INTP5	BLKCK	I	Subcode bitclock input
22	P06/INTP6	/INT	I	VCD Interrupt request
23	AVDD	AVDD	—	A/D converter analog power: +5V
24	AVref0	AVref0	—	A/D converter reference voltage input: 5V
25	P10/ANI0	KEY1	I	Unit operation button input1
26	P11/ANI1	KEY2	I	Unit operation button input2
27	P12/ANI2	KEY3	I	Not used: Connect to GND
28	P13/ANI3	KEY4	I	Not used: Connect to GND
29	P14/ANI4	TLOCK	I	CD-DSP TLOCK input H: LOCK
30	P15/ANI5	FLOCK	I	CD-DSP FLOCK input H: LOCK
31	P16/ANI6	SENCE	I	CD-DSP SENCE input
32	P17/ANI7	STAT	I	CD Status signal
33	AVss	AVss	—	A/D, D/A converter GND position
34	P130/ANO0	LINE1	O	LINE OUT Control signal output1
35	P131/ANO1	LINE2	O	LINE OUT Control signal output2

Pin. No.	Name	Symbol	I/O	Function
36	AVref1	AVref1	—	D/A converter reference voltage input
37	P70/RxD2/SI2	CDFL DATAI	I	cd-dsp/FL Data input
38	P71/TxD2/SO2	CDFL DATAO	O	cd-dsp/FL Data output
39	P72/ASCK2/SCK2	CDFL CLK	O	cd-dsp/FL Data CLOCK output
40	P20/RxD1/SI1	DATA RXD	I	DATA BUS (for VOL, PLL, RDS IC) Data input
41	P21/TxD1/SO1	DATA TXD	O	DATA BUS (for VOL, PLL, RDS IC) Data output
42	P22/ACSK1/SCK1	DATA CLK	O	DATA BUS (for VOL, PLL, RDS IC) Clock output
43	P23/PCL	DATA CE	O	DATA BUS (for VOL, PLL, RDS IC) Chip enable output
44	P24/BUZ	/RDSRST	O	RDS IC reset output
45	P25/SIO/SDA0	DB RXD	O	DENON BUS DATA INPUT
46	P26/SO0	DB TXD	I	DENON BUS DATA OUTPUT
47	P27/SCK0/SCL0	DB CLK	O	DENON BUS CLOCK OUTPUT
48	P80/A0	/SD	I	FM/AM Tuning signal input, Tuned: Low
49	P81/A1	/ST INC	I	FM stereo demodulation detect input, Stereo: Low
50	P82/A2	/TMUTE	O	Tuner mute output, mute: Low
51	P83/A3	SUCS	O	Subcode SELECT H: CD SUBQ CLOCK
52	P84/A4	USA	I	Initial setting input
53	P85/A5	EURO	I	Initial setting input
54	P86/A6	FREQ	I	Initial setting input
55	P87/A7	RDS	I	Initial setting input
56	P40/AD0	LED3G	O	Disc3 Green LED output, Light: High
57	P41/AD1	LED3R	O	Disc3 Red LED output, Light: High
58	P42/AD2	LED2G	O	Disc2 Green LED output, Light: High
59	P43/AD3	LED2R	O	Disc2 Red LED output, Light: High
60	P44/AD4	LED1G	O	Disc1 Green LED output, Light: High
61	P45/AD5	LED1R	O	Disc1 Red LED output, Light: High
62	P46/AD6	LED POWER G	O	POWER/STANDBY Green LED output, Light: High
63	P47/AD7	LED POWER R	O	POWER/STANDBY Red LED output, Light: High
64	P50/A8	EX SW	I	Changer mecha, Carriage Extra position: SW2 (X3)/not used: connect to ext. pulldown (X1)
65	P51/A9	HOME SW	I	Changer mecha, Carriage Home position: SW3 (X3)/not used: connect to ext. Pulldown (X1)
66	P52/A10	D2 SW	I	Changer mecha, Carriage number, SW5 (X3)/CD mecha. Closed SDW (X1)
67	P53/A11	D1 SW	I	Changer mecha, Carriage number, SW4 (X3)/CD mecha Open SW. (X1)
68	P54/A12	O/C SW	I	Changer mecha, Open/Close detect: SW6 (X3)/not used: connect to ext. pulldown (X1)
69	P55/A13	FWD SW	I	Changer mecha. slider Forward position: SW7 (X3)/not used: connect to ext. Pulldown (X1)
70	P56/A14	RVS SW	I	Changer mecha. Slider Reverse position: SW8 (X3)/not used: connect to ext. Pulldown (X1)
71	P57/A15		O	Not used: NC
72	Vss	Vss	—	GND potential
73	P60/A16	FL BLK	O	Putting out light of FL display H: lighting
74	P61/A17	N.C	O	
75	P62/A18	N.C	O	
76	P63/A19	N.C		
77	P64/RD	SRST	O	CD-DSP reset output, output, reset: High
78	P65/WR	VRST	O	VCD module output, reset: High
79	P66/WAIT	N.C	O	
80	P67/ASTB	N.C	O	
81	VDD	VDD	—	Positive power
82	P100/TI5/TO5	DRAWER-	O	Changer mecha. Drawer motor- (X3)/CD mecha. Open
83	P101/TI6/TO6	DRAWER+	O	Changer mecha. Drawer motor+ (X3)/CD mecha. Close
84	P102/TI7/TO7	CARRIGE-	O	Changer mecha. Carriage motor- (X3)/not used: NC (X1)
85	P103/TI8/TO8	CARRIGE+	O	Changer mecha, Carriage motor+ (X3)/not used: NC (X1)
86	P30/TO0	MLD	O	CD-DSP serial communication load output
87	P31/TO1	N.C	O	Not used: NC
88	P32/TO2	DMUTE	O	CD-DSP DMUTE, mute: High
89	P33/TI1	NTSC/PAL	I	NTSC/PAL switching input, NTSC: Low
90	P34/TI2	CDPOWER	O	CD power control signal output H: POWER ON
91	P35/TI00	CHA/SIG	I	3CD Changer/Single CD switching input, 3CD: High
92	P36/TI02		O	Not used: NC
93	P37	HPSW	I	HEADPHONE Insert switch detective signal input
94	TEST/VPP	TEST	I	not used: Connect to GND
95	P90	CD/VCD	I	CD/VCD switching input, CD: High
96	P91	INSW	I	Pickup inner-most detect input, inner most: Low at on
97	P92	VCL	O	VCD module clock output, CD: ext. Pullup
98	P93	VDI	I	VCD module data input, CD: ext. pullup
99	P94	VDO	O	VCD module data output
100	P95	VCE	O	VCD module serial communication select output

MN35511 (IC101)

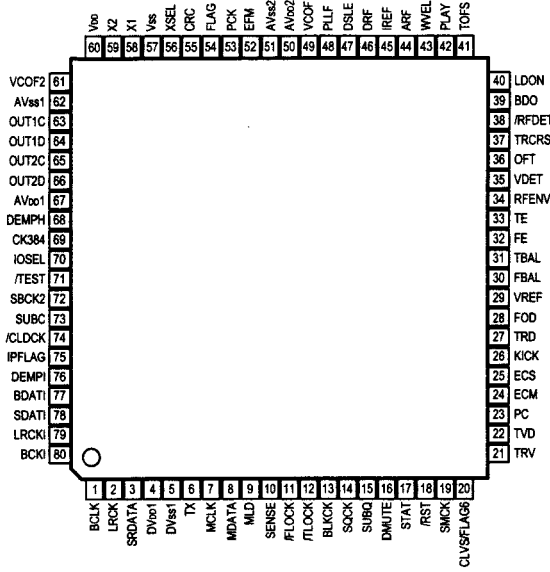

AN8816SB (IC103)

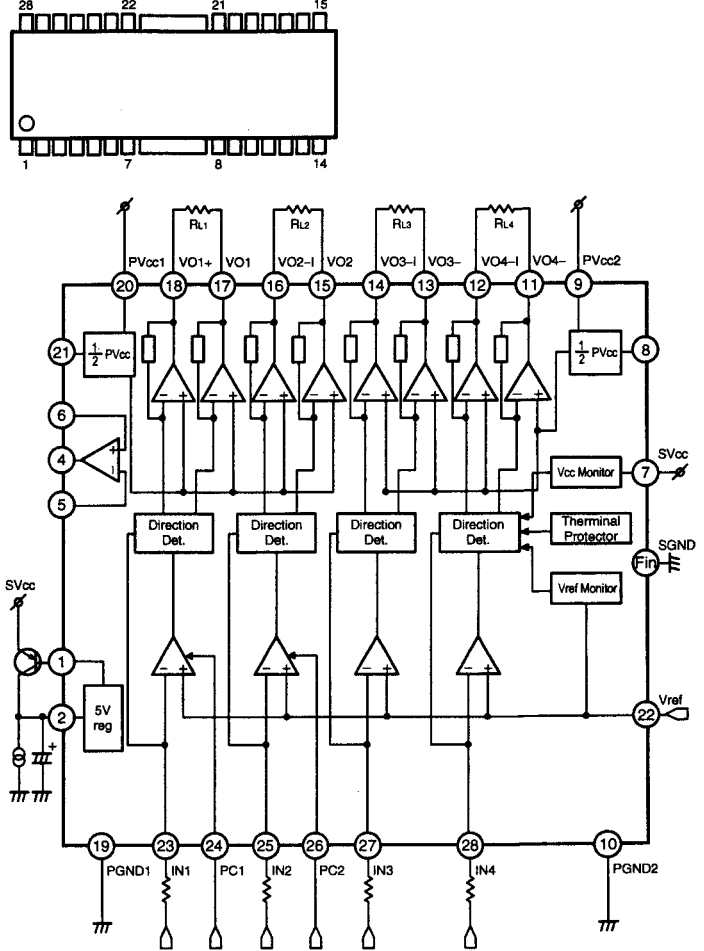

BA15218F (IC105, 106, 304, 305)

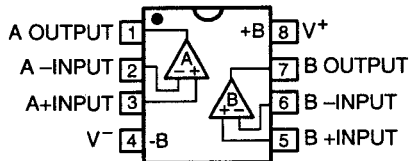

**NJM7805FA (IC203, 602, 605)
NJM7812FA (IC603, 604)**

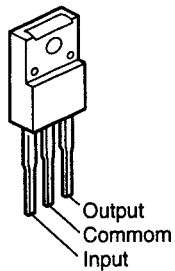

AN8807SB (IC102)

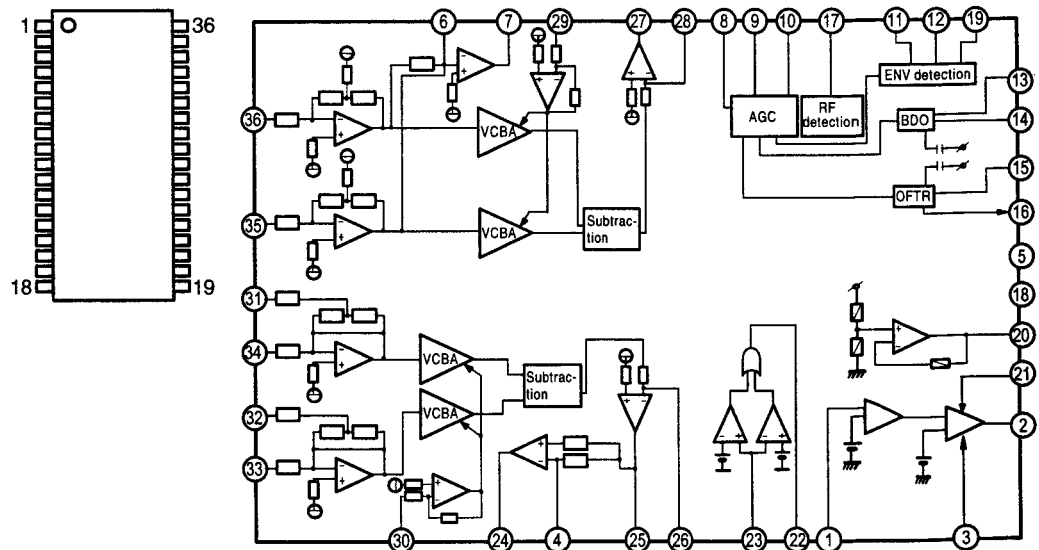

LC75725E (IC401)

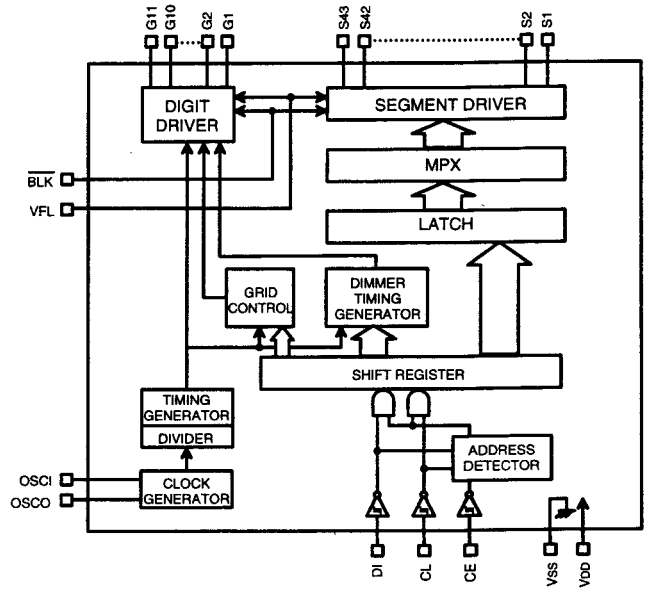
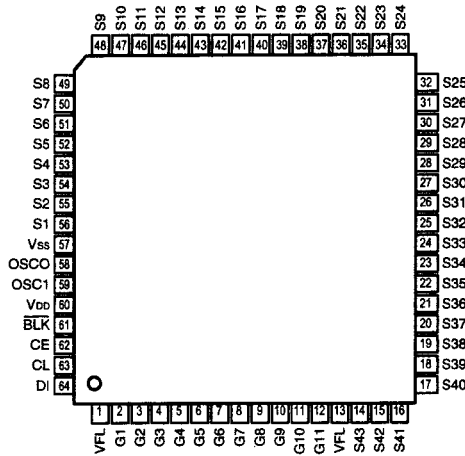

Terminal Function

Pin No.	I/O	Name	Function
1, 13	—	VFL	Power supply pin to driver block
2-12	O	G1-G11	Digit output pin
14-56	O	S1-S43	Segment output pin
57	—	Vss	Power supply pin
58	O	OSCO	Pin for oscillator
59	I	OSCI	Pin for oscillator
60	—	Vdd	Power supply pin to logic block
61	I	BLK	Display off input pin
62	I	CE	Input for serial data transfer
63	I	CL	CE: Chip enable CL: Sync clock
64	I	DI	DI: Transfer data

CE: Chip enable

BU4066BCF (IC206)

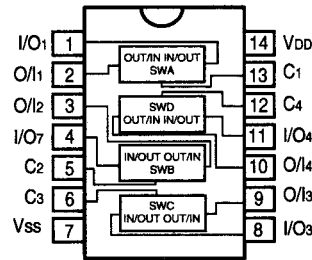

LC75342M (IC302)

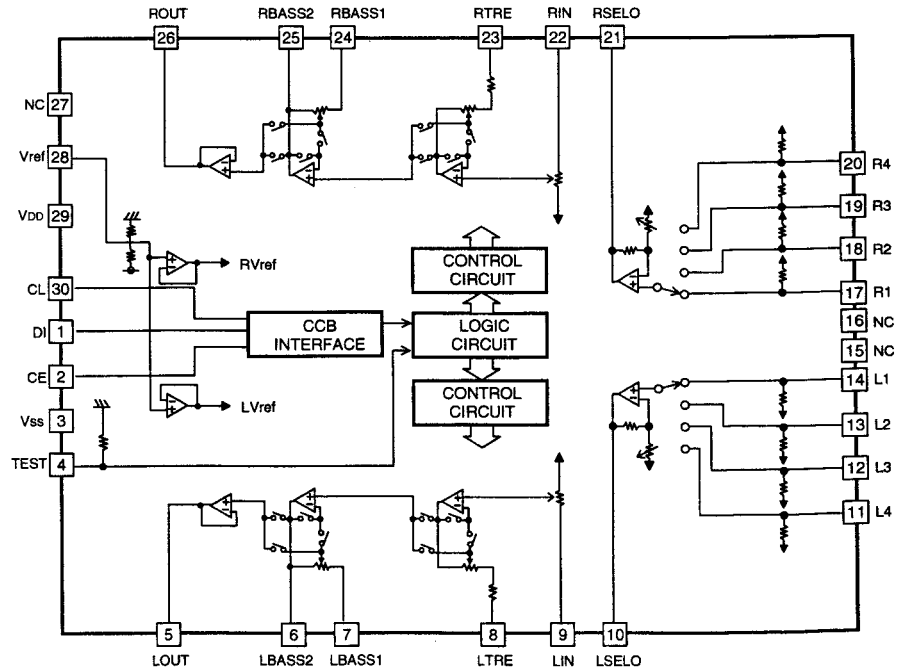
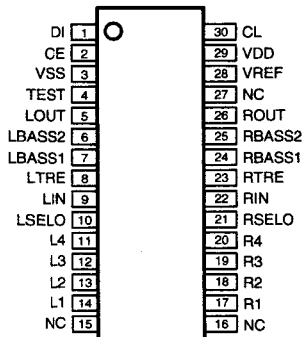

LC72720M (IC303)

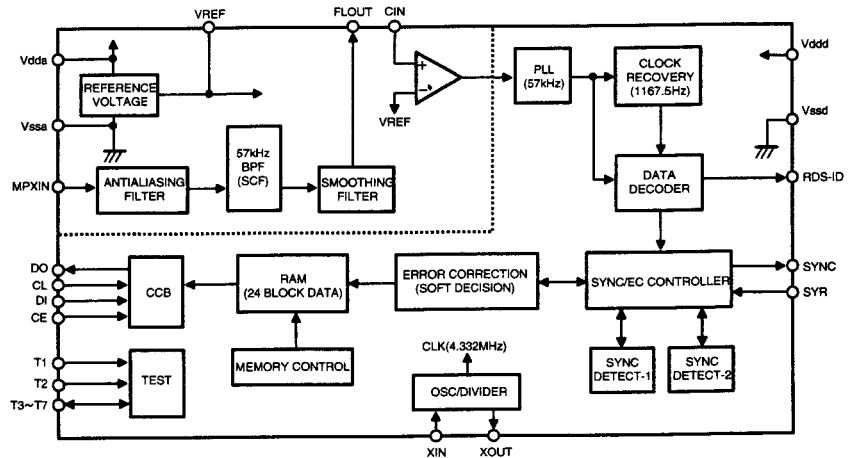
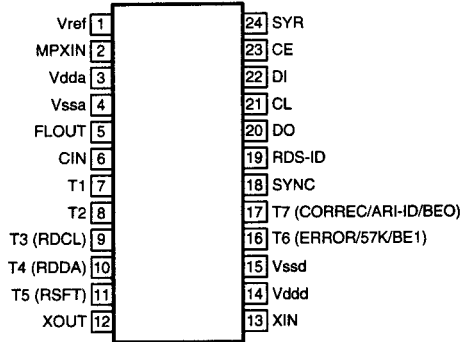

STK405-050A (IC501)

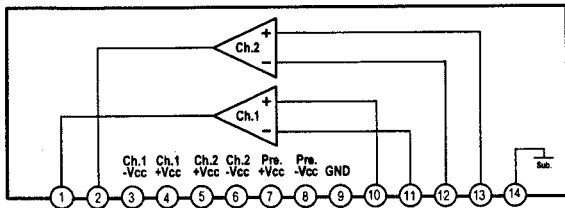
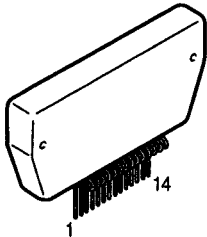

BA6287F (IC204)

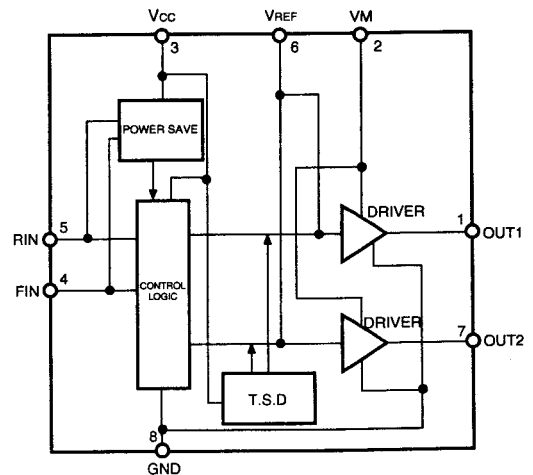
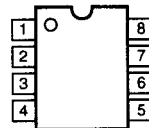

M51957BFP (IC205)

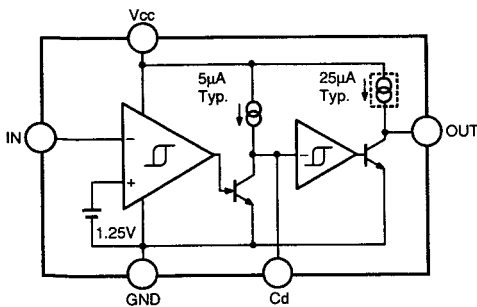
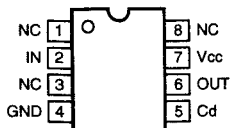

93LC66 (IC202)

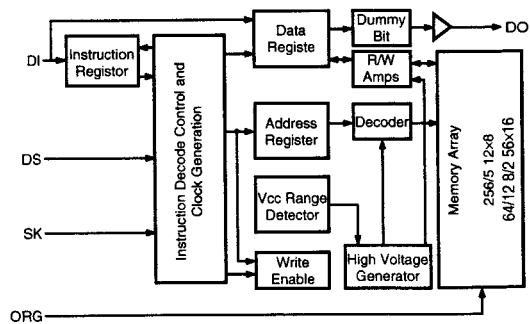
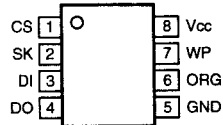

1 2 3 4 5 6 7 8

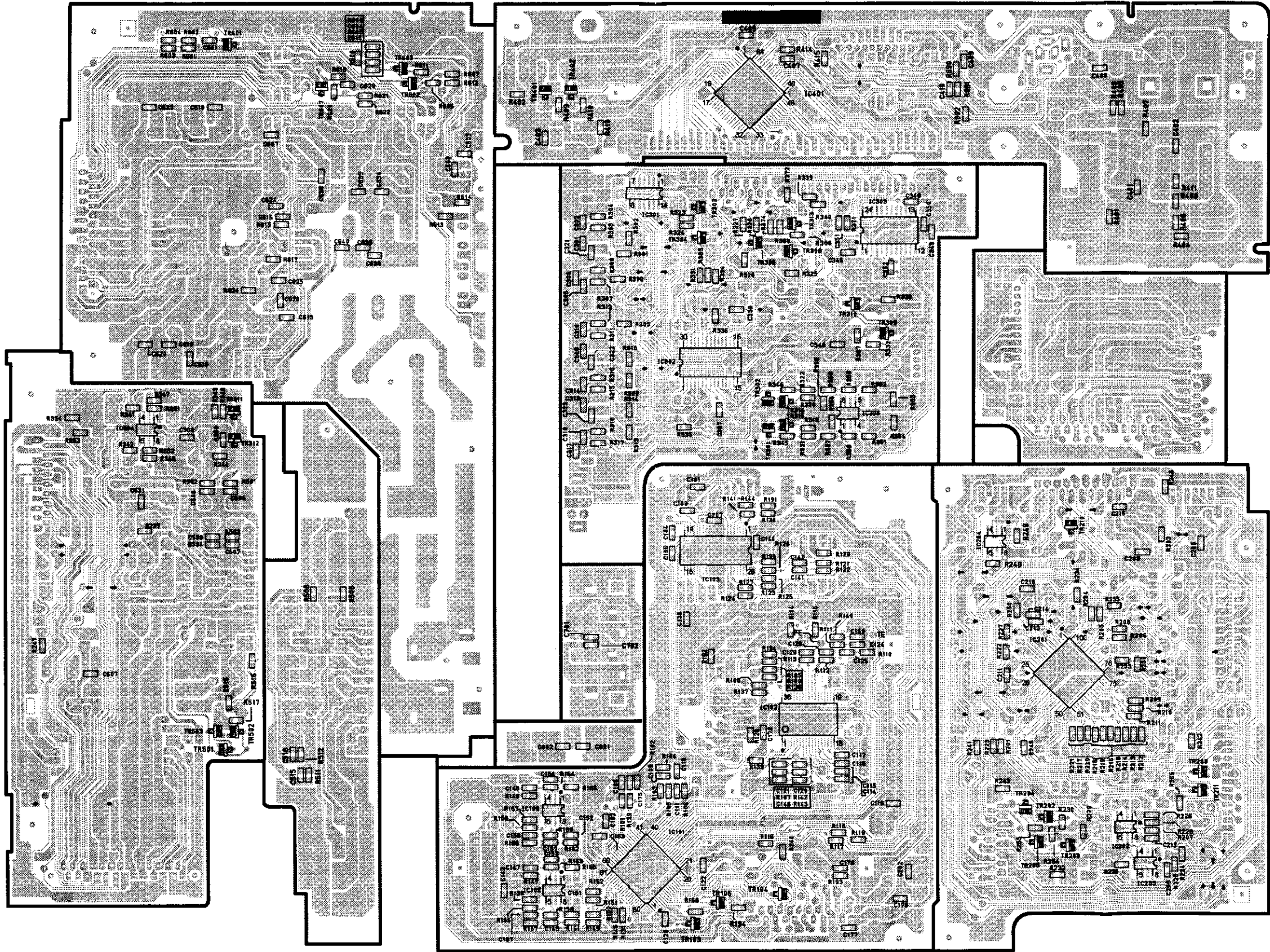

A
B
C
D
E

FOIL SIDE

NOTE FOR PARTS LIST

- Part indicated with the mark "⊙" are not always in stock and possibly to take a long period of time for supplying, or in some case supplying of part may be refused.
- When ordering of part, clearly indicate "1" and "I" (i) to avoid mis-supplying.
- Ordering part without stating its part number can not be supplied.
- Part indicated with the mark "★" is not illustrated in the exploded view.
- Not including Carbon Film ±5%, 1/4W Type in the P.W.Board parts list. (Refer to the Schematic Diagram for those parts.)

WARNING:

Parts marked with this symbol  have critical characteristics. Use ONLY replacement parts recommended by the manufacturer.

● Resistors

Ex.: RN 14K 2E 182 G ER

RD : Carbon	2B : 1/8W	F : ±1%	P : Pulse-resistant type
RC : Composition	2E : 1/4W	G : ±2%	NL : Low noise type
RS : Metal oxide film	2H : 1/2W	J : ±5%	NB : Non-burning type
RW : Winding	3A : 1W	K : ±10%	FR : Fuse-resistor
RN : Metal film	3D : 2W	M : ±20%	F : Lead wire forming
RK : Metal mixture	3F : 3W		
	3H : 5W		

* Resistance

$\overset{1}{\text{R}}\overset{2}{\text{R}} \Rightarrow 1800 \text{ ohm} = 1.8 \text{ kohm}$
Indicates number of zeros after effective number.
2-digit effective number.

• Units: ohm

$\overset{1}{\text{R}}\overset{2}{\text{R}} \Rightarrow 1.2 \text{ ohm}$
1-digit effective number.
2-digit effective number, decimal point indicated by R.

• Units: ohm

● Capacitors

Ex.: CE 04W 1H 2B2 M BP

CE : Aluminum foil electrolytic	0J : 6.3V	F : ±1%	HS : High stability type
CA : Aluminum solid electrolytic	1A : 10V	G : ±2%	BP : Non-polar type
CS : Tantalum electrolytic	1C : 16V	J : ±5%	HR : Ripple-resistant type
CQ : Film	1E : 25V	K : ±10%	DL : For charge and discharge
CK : Ceramic	1V : 35V	M : ±20%	HF : For assuring high frequency
CC : Ceramic	1H : 50V	Z : +80%	U : UL part
CP : Oil	2A : 100V	-20%	C : CSA part
CM : Mica	2B : 125V	P : +100%	W : UL-CSA type
CF : Metallized	2C : 160V	-0%	F : Lead wire forming
CH : Metallized	2D : 200V	C : ±0.25pF	
	2E : 250V	D : ±0.5pF	
	2H : 500V	= : Others	
	2J : 630V		

* Capacity (electrolyte only)

$\overset{2}{\text{R}}\overset{2}{\text{R}} \Rightarrow 2200\mu\text{F}$
Indicates number of zeros after effective number.
2-digit effective number.

• Units: μF .

$\overset{2}{\text{R}}\overset{2}{\text{R}} \Rightarrow 2.2\mu\text{F}$
1-digit effective number.
2-digit effective number, decimal point indicated by R.

• Units: μF .

* Capacity (except electrolyte)

$\overset{2}{\text{R}}\overset{2}{\text{R}} \Rightarrow 2200\text{pF} = 0.0022\mu\text{F}$
(More than 2) — Indicates number of zeros after effective number.
2-digit effective number.

• Units: pF.

$\overset{2}{\text{R}}\overset{2}{\text{R}}\overset{1}{\text{R}} \Rightarrow 220\text{pF}$
(0 or 1) — Indicates number of zeros after effective number.
2-digit effective number.

• Units: pF.

• When the dielectric strength is indicated in AC, "AC" is included after the dielectric strength value.

**PARTS LIST OF P.W.B. UNIT ASS'Y
MAIN P.W.B. UNIT**

Ref. No.	Part No.	Part Name	Remarks	Ref. No.	Part No.	Part Name	Remarks
SEMICONDUCTORS							
IC101	262 2815 008	IC MN35511	CD DSP	TR502,503	273 0426 907	Transistor 2SC2412KLNT	
IC102	262 2462 901	IC AN8807SB	CD DRIVER	TR601	271 0238 908	Transistor 2SA1037K(S/R)	
IC103	262 2461 902	IC AN8816SB	CD RF	TR602,603	273 0426 907	Transistor 2SC2412KLNT	
IC105	263 0615 902	IC BA15218F		TR604	269 0160 905	Transistor DTC143ZSAT	
IC106	263 0615 902	IC BA15218F		TR605	272 0025 907	Transistor 2SB562(C)T	
IC201	262 2814 009	IC UPD784216AGC-109-8EU	MICON	TR606	269 0160 905	Transistor DTC143ZSAT	
IC202	951 0011 807	IC 93LC66 /A	EEPROM	TR607	273 0426 907	Transistor 2SC2412KLNT	
IC203	263 0553 006	IC NJM7805FA		D301-304	276 0375 002	Diode 1N4148	
IC204	263 0994 908	IC BA6287F	LOADER DRIVER	D601	276 0375 002	Diode 1N4148	
IC205	263 0454 901	IC M51957BFP	RESET	D602,603	GP6 0004 002	Diode 1N4004	
IC301	262 1875 900	IC BU4066BCF	ANALOG SW	D604-606	276 0375 002	Diode 1N4148	
IC302	951 0011 904	IC LC75342M	SELV/VOL/TONE	D607-610	GP6 0004 002	Diode 1N4004	
IC303	262 2547 907	IC LC72720NM	RDS	D611	951 0012 301	Diode D3SBA60	
IC304,305	263 0615 902	IC BA15218F		D612,613	GP6 0004 002	Diode 1N4004	
IC401	951 0012 000	IC LC75725E	FLD DRIVER	D614	276 0375 002	Diode 1N4148	
IC402	499 0301 006	IC RPM6938-V4	SENSOR	D615,616	GP6 0004 002	Diode 1N4004	
IC501	951 0012 107	IC STK405-050	POWER IC	LD401	951 0012 204	LED SLR-9336DS-91	POWER LED
IC601	951 0010 002	IC TOTX178A	OPTICAL OUT	ZD201	276 0644 966	Zener diode MTZJ12AT	
IC602	263 0553 006	IC NJM7805FA		ZD202	951 0012 602	Zener diode MTZJ3.6AT	
IC603,604	263 0516 001	IC NJM7812FA		ZD601,602	951 0022 401	Zener diode MTZJ6.2AT	
IC605	263 0553 006	IC NJM7805FA		ZD603	951 0012 709	Zener diode MTZJ5.6AT	
 IC606,607	268 0073 905	IC ICP-N15T	IC PROTECTOR	ZD604	951 0012 505	Zener diode MTZJ33CT	
TR102	271 0183 927	Transistor 2SA933(R/S)T-93		RESISTOR			
TR103	269 0082 902	Transistor DTC114EKT96		R101	247 0006 988	Carbon chip 560 ohm 1/10W	RM73B--561J
TR104,105	269 0106 901	Transistor DTA144TK96		R102			OPEN(CHIP R)
TR201	272 0025 907	Transistor 2SB562(C)T		R103	247 0012 927	Carbon chip 100 kohm 1/10W	RM73B--104J
TR202-205	273 0414 906	Transistor 2SC3326 (A/B)		R104	247 0014 967	Carbon chip 1 Mohm 1/10W	RM73B--105J
TR206	269 0020 906	Transistor DTC114ES(10K-10k)		R105	247 0011 944	Carbon chip 47 kohm 1/10W	RM73B--473J
TR209	269 0185 906	Transistor DTA115TK96		R106	247 0012 943	Carbon chip 120 kohm 1/10W	RM73B--124J
TR210	269 0088 906	Transistor DTC114TK96		R107	247 0007 967	Carbon chip 1.5 kohm 1/10W	RM73B--152J
TR211	269 0083 901	Transistor DTA114EKT96		R108,109	247 0010 929	Carbon chip 15 kohm 1/10W	RM73B--153J
TR301,302	269 0066 902	Transistor DTC323TKT96		R110	247 0013 900	Carbon chip 220 kohm 1/10W	RM73B--224J
TR303,304	269 0054 901	Transistor DTC144EKT96		R111,112	247 0011 928	Carbon chip 39 kohm 1/10W	RM73B--393J
TR306,308	269 0066 902	Transistor DTC323TKT96		R113	247 0009 985	Carbon chip 10 kohm 1/10W	RM73B--103J
TR309	273 0426 907	Transistor 2SC2412KLNT		R114	247 0013 968	Carbon chip 390 kohm 1/10W	RM73B--394J
TR310	269 0083 901	Transistor DTA114EKT96		R115	247 0013 942	Carbon chip 330 kohm 1/10W	RM73B--334J
TR311,312	269 0066 902	Transistor DTC323TKT96		R116	247 0012 969	Carbon chip 150 kohm 1/10W	RM73B--154J
TR313	269 0082 902	Transistor DTC114EKT96		R117	247 0011 944	Carbon chip 47 kohm 1/10W	RM73B--473J
TR315,316	269 0066 902	Transistor DTC323TKT96		R118	247 0011 986	Carbon chip 68 kohm 1/10W	RM73B--683J
TR401,402	269 0082 902	Transistor DTC114EKT96		R119	247 0008 944	Carbon chip 2.7 kohm 1/10W	RM73B--272J
TR501	271 0238 908	Transistor 2SA1037K(S/R)		R120	247 0013 900	Carbon chip 220 kohm 1/10W	RM73B--224J
				R121	247 0011 986	Carbon chip 68 kohm 1/10W	RM73B--683J
				R122	247 0011 902	Carbon chip 33 kohm 1/10W	RM73B--333J
				R123	247 0009 901	Carbon chip 4.7 kohm 1/10W	RM73B--472J
				R124,125	247 0008 902	Carbon chip 1.8 kohm 1/10W	RM73B--182J

Ref. No.	Part No.	Part Name	Remarks	Ref. No.	Part No.	Part Name	Remarks
R126	247 0007 945	Carbon chip 1 kohm 1/10W	RM73B--102J	R219		Carbon chip 4.7 kohm 1/10W	RM73B--472J
R127	247 0018 905	Carbon chip 0 ohm 1/10W	RM73B--0R0J	R220			OPEN(CHIP R)
R128	247 0005 905	Carbon chip 100 ohm 1/10W	RM73B--101J				for E2,EK,E3
R129	247 0007 903	Carbon chip 680 ohm 1/10W	RM73B--681J	R220	247 0009 901	Carbon chip 4.7 kohm 1/10W	RM73B--472J
R130	247 0010 961	Carbon chip 22 kohm 1/10W	RM73B--223J				for E1
R131	247 0018 905	Carbon chip 0 ohm 1/10W	RM73B--0R0J	R221	247 0009 901	Carbon chip 4.7 kohm 1/10W	RM73B--472J
R132	204 8416 007	Carbon film 18ohm 1/4W	RD14B2E180JT				for E2,EK
R133	247 0018 905	Carbon chip 0 ohm 1/10W	RM73B--0R0J	R221			OPEN(CHIP R)
R134,135	247 0012 969	Carbon chip 150 kohm 1/10W	RM73B--154J				for E3,E1
R136	247 0010 929	Carbon chip 15 kohm 1/10W	RM73B--153J	R222	247 0007 945	Carbon chip 1 kohm 1/10W	RM73B--102J
R137	247 0010 929	Carbon chip 15 kohm 1/10W	RM73B--153J	R223	247 0009 985	Carbon chip 10 kohm 1/10W	RM73B--103J
R139	247 0005 905	Carbon chip 100 ohm 1/10W	RM73B--101J	R224	247 0010 903	Carbon chip 15 kohm 1/10W	RM73B--153J
R140			OPEN(CHIP R)	R225	247 0011 902	Carbon chip 33 kohm 1/10W	RM73B--333J
R141	247 0018 905	Carbon chip 0 ohm 1/10W	RM73B--0R0J	R226--228	247 0009 985	Carbon chip 10 kohm 1/10W	RM73B--103J
R142	247 0008 902	Carbon chip 1.8 kohm 1/10W	RM73B--182J	R229	247 0008 928	Carbon chip 2.2 kohm 1/10W	RM73B--222J
R143	247 0007 945	Carbon chip 1 kohm 1/10W	RM73B--102J	R230	247 0008 928	Carbon chip 2.2 kohm 1/10W	RM73B--222J
R144	247 0018 905	Carbon chip 0 ohm 1/10W	RM73B--0R0J	R231	244 2043 953	Metal oxide 470 ohm 1W	RS14B3A471JNBST(S)
R145			OPEN(CHIP R)	R232	247 0010 961	Carbon chip 22 kohm 1/10W	RM73B--223J
R147	247 0009 985	Carbon chip 10 kohm 1/10W	RM73B--103J	R234,235	247 0010 916	Carbon chip 10 kohm 1/10W	RM73B--103J
R148	247 0009 985	Carbon chip 15 kohm 1/10W	RM73B--103J	R236	247 0007 945	Carbon chip 1 kohm 1/10W	RM73B--102J
R149~152	247 0012 998	Carbon chip 200 kohm 1/10W	RM73B--204J	R237	247 0009 901	Carbon chip 4.7 kohm 1/10W	RM73B--472J
R155~157	247 0008 960	Carbon chip 3.3 kohm 1/10W	RM73B--332J	R238	244 2043 953	Metal oxide 470 ohm 1W	RS14B3A471JNBST(S)
R158	247 0005 989	Carbon chip 220 ohm 1/10W	RM73B--221J	R239	247 0007 945	Carbon chip 1 kohm 1/10W	RM73B--102J
R159,160	247 0007 961	Carbon chip 1.2 kohm 1/10W	RM73B--122J	R240	247 0011 944	Carbon chip 47 kohm 1/10W	RM73B--473J
R161,162	247 0011 960	Carbon chip 56 kohm 1/10W	RM73B--563J	R241~243	247 0018 905	Carbon chip 0 ohm 1/10W	RM73B--0R0J
R163,164	247 0006 988	Carbon chip 560 ohm 1/10W	RM73B--561J	R245,246	247 0018 905	Carbon chip 0 ohm 1/10W	RM73B--0R0J
R165,166	247 0006 991	Carbon chip 620 ohm 1/10W	RM73B--621J	R247	247 0009 901	Carbon chip 4.7 kohm 1/10W	RM73B--472J
R167	247 0018 905	Carbon chip 0 ohm 1/10W	RM73B--0R0J	R249		Carbon film 330 ohm 1/4W	RD14B2E331JT
R168	247 0008 960	Carbon chip 3.3 kohm 1/10W	RM73B--332J	R250	247 0008 915	Carbon chip 2 kohm 1/10W	RM73B--202J
R190			OPEN(CHIP R)	R251,252	244 2055 941	Metal oxide 330 ohm 1W	RS14B3A331JNBST(S)
R191	247 0007 945	Carbon chip 1 kohm 1/10W	RM73B--102J	R253	247 0011 944	Carbon chip 47 kohm 1/10W	RM73B--473J
R192	247 0009 985	Carbon chip 10 kohm 1/10W	RM73B--103J	R254,255	247 0008 928	Carbon chip 2.2 kohm 1/10W	RM73B--222J
R193	247 0008 915	Carbon chip 2 kohm 1/10W	RM73B--202J				
R194	247 0018 905	Carbon chip 0 ohm 1/10W	RM73B--0R0J	R301,302	247 0013 984	Carbon chip 470 kohm 1/10W	RM73B--474J
R199		Carbon film 1 kohm 1/4W	RD14B2E102JT	R303,304	247 0006 962	Carbon chip 470 ohm 1/10W	RM73B--471J
				R305,306	247 0013 984	Carbon chip 470 kohm 1/10W	RM73B--474J
R201	247 0009 985	Carbon chip 10 kohm 1/10W	RM73B--103J	R307,308	247 0006 962	Carbon chip 470 ohm 1/10W	RM73B--471J
R202		Carbon film 1.2 kohm 1/4W	RD14B2E122JT	R309	247 0013 984	Carbon chip 470 kohm 1/10W	RM73B--474J
R203	247 0009 985	Carbon chip 10 kohm 1/10W	RM73B--103J	R310	247 0013 984	Carbon chip 470 kohm 1/10W	RM73B--474J
R204~208	247 0011 944	Carbon chip 47 kohm 1/10W	RM73B--473J	R311,312	247 0006 962	Carbon chip 470 ohm 1/10W	RM73B--471J
R209~213	247 0009 914	Carbon chip 4.7 kohm 1/10W	RM73B--472J	R313,314	247 0013 984	Carbon chip 470 kohm 1/10W	RM73B--474J
R214	247 0009 901	Carbon chip 4.7 kohm 1/10W	RM73B--472J	R315~318	247 0006 962	Carbon chip 470 ohm 1/10W	RM73B--471J
			for E2,EK	R319,320	247 0012 927	Carbon chip 100 kohm 1/10W	RM73B--104J
R214			OPEN(CHIP R)	R321,322	247 0008 915	Carbon chip 2 kohm 1/10W	RM73B--202J
			for E3,E1	R323~326	247 0009 985	Carbon chip 10 kohm 1/10W	RM73B--103J
R215			OPEN(CHIP R)	R327,328	247 0007 945	Carbon chip 1 kohm 1/10W	RM73B--102J
R216	247 0009 901	Carbon chip 4.7 kohm 1/10W	RM73B--472J	R331~334	247 0007 945	Carbon chip 1 kohm 1/10W	RM73B--102J
R216			for E2,EK,E1	R335,336	247 0008 973	Carbon chip 3.6 kohm 1/10W	RM73B--362J
R217,218			OPEN(CHIP R)	R337	247 0009 956	Carbon chip 7.5 kohm 1/10W	RM73B--752J
			for E2,EK	R338	247 0009 901	Carbon chip 4.7 kohm 1/10W	RM73B--472J
R217,218	247 0009 901	Carbon chip 4.7 kohm 1/10W	RM73B--472J	R339,340	247 0012 927	Carbon chip 100 kohm 1/10W	RM73B--104J
	247 0009 901		for E3,E1	R341,342	247 0011 944	Carbon chip 47 kohm 1/10W	RM73B--473J

Ref. No.	Part No.	Part Name	Remarks
R343,344	247 0008 915	Carbon chip 2 kohm 1/10W	RM73B--202J
R345,346	247 0011 944	Carbon chip 470 ohm 1/10W	RM73B--471J
R347,348	247 0007 945	Carbon chip 1kohm 1/10W	RM73B--102J
R349,350	247 0012 927	Carbon chip 100 kohm 1/10W	RM73B--104J
R351,352	247 0008 931	Carbon chip 2.4 kohm 1/10W	RM73B--242J
R353	247 0009 901	Carbon chip 4.7 kohm 1/10W	RM73B--472J
R354	247 0009 901	Carbon chip 4.7 kohm 1/10W	RM73B--472J
R355,356	247 0012 927	Carbon chip 100 kohm 1/10W	RM73B--104J
R357	247 0009 969	Carbon chip 8.2 kohm 1/10W	RM73B--822J
R358	247 0009 969	Carbon chip 8.2 kohm 1/10W	RM73B--822J
R359,360	247 0007 987	Carbon chip 1.5 kohm 1/10W	RM73B--152J
R361,362	247 0011 944	Carbon chip 47 kohm 1/10W	RM73B--473J
R363	247 0009 901	Carbon chip 4.7 kohm 1/10W	RM73B--472J
R364	247 0009 901	Carbon chip 4.7 kohm 1/10W	RM73B--472J
R365	247 0009 901	Carbon chip 4.7 kohm 1/10W	RM73B--472J
R368	247 0008 915	Carbon chip 2 kohm 1/10W	RM73B--202J
R369	247 0009 901	Carbon chip 4.7 kohm 1/10W	RM73B--472J
R371	247 0011 944	Carbon chip 47 kohm 1/10W	RM73B--473J
R372	247 0011 944	Carbon chip 47 kohm 1/10W	RM73B--473J
R374	247 0009 985	Carbon chip 10 kohm 1/10W	RM73B--103J
R401	247 0006 946	Carbon chip 390 ohm 1/10W	RM73B--391J
R402	247 0007 903	Carbon chip 680 ohm 1/10W	RM73B--681J
R403	247 0006 904	Carbon chip 270 ohm 1/10W	RM73B--271J
R404	247 0006 946	Carbon chip 390 ohm 1/10W	RM73B--391J
R405	247 0005 963	Carbon chip 180 ohm 1/10W	RM73B--181J
R406	247 0006 904	Carbon chip 270 ohm 1/10W	RM73B--271J
R407	247 0005 947	Carbon chip 150 ohm 1/10W	RM73B--151J
R408	247 0005 963	Carbon chip 180 ohm 1/10W	RM73B--181J
R409	247 0005 959	Carbon chip 220 ohm 1/10W	RM73B--221J
R410	247 0006 917	Carbon chip 330 ohm 1/10W	RM73B--331J
R411	247 0005 947	Carbon chip 150 ohm 1/10W	RM73B--151J
R413	247 0004 922	Carbon chip 47 ohm 1/10W	RM73B--470J
R414	247 0009 927	Carbon chip 5.6 kohm 1/10W	RM73B--562J
R415	247 0009 901	Carbon chip 4.7 kohm 1/10W	RM73B--472J
R501,502	247 0007 945	Carbon chip 1 kohm 1/10W	RM73B--102J
R503,504	247 0011 960	Carbon chip 56 kohm 1/10W	RM73B--563J
R505,506	247 0008 944	Carbon chip 2.7 kohm 1/10W	RM73B--272J
R507,508	244 2043 937	Metal oxide 4.7 ohm 1W	RS14B3A4R7JNBST(S)
Δ R509,510		Fusible 100 ohm 1/4W	RD14B2E101GFRST
R511,512	247 0011 960	Carbon chip 56 kohm 1/10W	RM73B--563J
R513,514	244 2051 987	Metal oxide 10 ohm 1W	RS14B3A100JNBST(S)
R515-517	247 0010 961	Carbon chip 22 kohm 1/10W	RM73B--223J
R599		Carbon film 3 kohm 1/4W	RD14B2E302JT
R601	247 0009 985	Carbon chip 10 kohm 1/10W	RM73B--103J
R602	247 0010 961	Carbon chip 22 kohm 1/10W	RM73B--223J
R603	247 0009 985	Carbon chip 10 kohm 1/10W	RM73B--103J
R604	247 0010 961	Carbon chip 22 kohm 1/10W	RM73B--223J
R605	247 0009 985	Carbon chip 10 kohm 1/10W	RM73B--103J
R606,607	247 0010 961	Carbon chip 22 kohm 1/10W	RM73B--223J

Ref. No.	Part No.	Part Name	Remarks
R608	247 0008 928	Carbon chip 2.2 kohm 1/10W	RM73B--222J
R609	247 0010 961	Carbon chip 22 kohm 1/10W	RM73B--223J
R610	247 0007 945	Carbon chip 1 kohm 1/10W	RM73B--102J
R611	247 0010 961	Carbon chip 22 kohm 1/10W	RM73B--223J
R612	247 0011 944	Carbon chip 47 kohm 1/10W	RM73B--473J
R613	247 0005 959	Carbon chip 220 ohm 1/10W	RM73B--221J
R614-616	247 0005 905	Carbon chip 100 ohm 1/10W	RM73B--101J
R617	247 0008 960	Carbon chip 3.3 kohm 1/10W	RM73B--332J
R618	244 2051 987	Metal oxide 10 ohm 1W	RS14B3A100JNBST(S)
R619,620	247 0009 985	Carbon chip 10 kohm 1/10W	RM73B--103J
R621	247 0008 915	Carbon chip 2 kohm 1/10W	RM73B--202J
R622	247 0009 985	Carbon chip 10 kohm 1/10W	RM73B--103J
Δ R623		Composition 2.7 Mohm 1/2W	RC05GF2H275K
R623			for E3 OPEN(R) for E2,EK
R624	247 0011 944	Carbon chip 47 kohm 1/10W	RM73B--473J
Δ R625	244 2051 945	Metal oxide 1 ohm 1W	RS14B3A010JNBST(S)
R990-992	247 0018 905	Carbon chip 0 ohm 1/10W	RM73B--0R0J
CAPACITORS			
C102	256 1058 971	Metalized 0.1μF/50V	CF93A1H104JT(JL)
C105			OPEN(CHIP C)
C107	256 1059 938	Metalized 0.33μF/50V	CF93A1H334JT(JL)
C108	254 4524 927	Electrolytic 0.33μF/50V	CE04W1HR33MT
C109,110	257 0012 982	Ceramic chip 0.022μF/50V	CK73F1H223ZT
C111	257 0006 901	Ceramic chip 390pF/50V	CC73C1H391JT
C112	254 4524 943	Electrolytic 1μF/50V	CE04W1H010MT
C113	254 4524 901	Electrolytic 0.1μF/50V	CE04W1H0R1MT
C114	257 0004 961	Ceramic chip 100pF/50V	CC73C1H101JT
C115	257 0010 955	Ceramic chip 0.027μF/50V	CK73B1H273KT
C116,117	257 0008 983	Ceramic chip 1000pF/50V	CK73B1H102JT
C118	257 0014 935	Ceramic chip 0.1μF/25V	CK73F1E104ZT
C119	254 4536 931	Electrolytic 330μF/10V	CE04W1A331MT
C120	257 0013 907	Ceramic chip 0.047μF/50V	CK73F1H473ZT
C121	257 0002 921	Ceramic chip 10pF/50V	CC73C1H100DT
C122	257 0004 961	Ceramic chip 100pF/50V	CC73C1H101JT
C123	257 0014 935	Ceramic chip 0.1μF/25V	CK73F1E104ZT
C124	257 0014 906	Ceramic chip 0.033μF/25V	CK73F1E333KT
C125	257 0009 966	Ceramic chip 4700pF/50V	CK73B1H472JT
C126,127	256 1058 971	Metalized 0.1μF/50V	CF93A1H104JT(JL)
C128,129	257 0006 969	Ceramic chip 680pF/50V	CC73C1H681JT
C130	256 1058 971	Metalized 0.1μF/50V	CF93A1H104JT(JL)
C131	254 4536 928	Electrolytic 100μF/10V	CE04W1A101MT
C132	254 4536 901	Electrolytic 220μF/10V	CE04W1A221MT
C133	254 4524 901	Electrolytic 0.1μF/50V	CE04W1HOR1MT
C134	254 4536 928	Electrolytic 100μF/10V	CE04W1A101MT
C135	257 0010 900	Ceramic chip 0.01μF/50V	CK73B1H103KT
C136	254 4538 942	Electrolytic 100μF/16V	CE04W1C101MT
C137	257 0013 907	Ceramic chip 0.047μF/50V	CK73F1H473ZT
C138	255 1265 994	Poly film 0.033μF/50V	CQ93M1H333JT(B)

Ref. No.	Part No.	Part Name	Remarks	Ref. No.	Part No.	Part Name	Remarks
C139	256 1059 912	Metalized 0.22μF/50V	CF93A1H224JT(JL)	C324	254 4524 901	Electrolytic 0.1μF/50V	CE04W1H0R1MT
C140	257 0009 924	Ceramic chip 2200pF/50V	CK73B1H222JT	C325-330	254 4524 972	Electrolytic 4.7μF/50V	CE04W1H4R7MT
C141	257 0008 983	Ceramic chip 1000pF/50V	CK73B1H102JT	C331-334	256 1058 971	Metalized 0.1μF/50V	CF93A1H104JT(JL)
C142	257 0014 935	Ceramic chip 0.1μF/25V	CK73F1E104ZT	C337,338	257 0009 937	Ceramic chip 2700pF/50V	CK73B1H272JT
C143	257 0006 943	Ceramic chip 560pF/50V	CC73C1H561JT	C339	254 4538 913	Electrolytic 22μF/16V	CE04W1C220MT
C144	257 0010 900	Ceramic chip 0.01μF/50V	CK73B1H103KT	C340	257 0012 966	Ceramic chip 0.01μF/50V	CK73F1H103ZT
C145		Electrolytic 330μF/16V	CE04W1C331MT	C341-343	254 4538 900	Electrolytic 10μF/16V	CE04W1C100MT
C146	257 0004 987	Ceramic chip 120pF/50V	CC73C1H121JT	C344	254 4536 915	Electrolytic 47μF/10V	CE04W1A470MT
C147,148	257 0009 940	Ceramic chip 3300pF/50V	CK73B1H332JT	C345,346	257 0012 966	Ceramic chip 0.01μF/50V	CK73F1H103ZT
C149	254 4524 956	Electrolytic 2.2μF/50V	CE04W1H2R2MT	C347	254 4538 900	Electrolytic 10μF/16V	CE04W1C100MT
C150	254 4536 902	Electrolytic 22μF/10V	CE04W1A220MT	C348	254 4524 972	Electrolytic 4.7μF/50V	CE04W1H4R7MT
C151,152	257 0004 961	Ceramic chip 100pF/50V	CC73C1H101JT	C349,350	257 0016 917	Ceramic chip 22pF/50V	CC73C1H220JT
C153,154	257 0012 982	Ceramic chip 0.022μF/50V	CK73F1H223ZT	C351	257 0005 986	Ceramic chip 330pF/50V	CC73C1H331JT
C155	254 4536 902	Electrolytic 22μF/10V	CE04W1A220MT	C352	257 0006 943	Ceramic chip 560pF/50V	CC73C1H561JT
C156	257 0013 907	Ceramic chip 0.047μF/50V	CK73F1H473ZT	C353-356	254 4524 972	Electrolytic 4.7μF/50V	CE04W1H4R7MT
C157	257 0006 943	Ceramic chip 560pF/50V	CC73C1H561JT	C357-359	254 4538 939	Electrolytic 47μF/16V	CE04W1C470MT
C159			OPEN(CHIP C)	C360	254 4524 901	Electrolytic 0.1μF/50V	CE04W1H0R1MT
C162,163	257 0503 996	Ceramic chip 20pF/50V	CC73C1H200JT	C361,362	254 4538 939	Electrolytic 47μF/16V	CE04W1C470MT
C172			OPEN(CHIP C)	C363,364	254 4524 972	Electrolytic 4.7μF/50V	CE04W1H4R7MT
C173	254 4524 972	Electrolytic 4.7μF/50V	CE04W1H4R7MT	C365	254 4538 939	Electrolytic 47μF/16V	CE04W1C470MT
C175			OPEN(CHIP C)	C366	254 4538 900	Electrolytic 10μF/16V	CE04W1C100MT
C176	257 0014 935	Ceramic chip 0.1μF/25V	CK73F1E104ZT	C367	254 4524 901	Electrolytic 0.1μF/50V	CE04W1H0R1MT
C177,178			OPEN(CHIP C)	C368	257 0012 966	Ceramic chip 0.01μF/50V	CK73F1H103ZT
C180	257 0014 935	Ceramic chip 0.1μF/25V	CK73F1E104ZT	C401-403			OPEN(CHIP C)
C182		Ceramic 0.01μF/50V	CK45F1H103ZT	C404	254 4536 915	Electrolytic 47μF/10V	CE04W1A470MT
C199	254 4538 942	Electrolytic 100μF/16V	CE04W1C101MT	C405	257 0012 966	Ceramic chip 0.01μF/50V	CK73F1H103ZT
C201	254 4538 900	Electrolytic 10μF/25V	CE04W1E100MT	C406	254 4536 915	Electrolytic 47μF/10V	CE04W1A470MT
C202,203	257 0012 966	Ceramic chip 0.01μF/50V	CK73F1H103ZT	C407	257 0003 904	Ceramic chip 22pF/50V	CC73C1H220JT
C204	254 4538 900	Electrolytic 10μF/25V	CE04W1E100MT	C409,410	257 0008 983	Ceramic chip 1000pF/50V	CK73B1H102JT
C205	257 0010 900	Ceramic chip 0.01μF/50V	CK73B1H103KT	C501,502	254 4524 972	Electrolytic 4.7μF/50V	CE04W1H4R7MT
C206	254 4538 900	Electrolytic 10μF/16V	CE04W1C100MT	C503,504	254 4524 998	Electrolytic 22μF/50V	CE04W1H220MT
C207	257 0010 900	Ceramic chip 0.01μF/50V	CK73B1H103ZT	C505,506	257 0006 927	Ceramic chip 470pF/50V	CC73C1H471JT
C208	257 0014 935	Ceramic chip 0.1μF/25V	CK73F1E104ZT	C507,508			OPEN(CHIP C)
C209	254 4524 956	Electrolytic 2.2μF/50V	CE04W1H2R2MT	C509,510	254 4525 926	Electrolytic 100μF/50V	CE04W1H101MT
C210	254 4538 939	Electrolytic 47μF/16V	CE04W1C470MT	C511,512	256 1058 971	Metalized 0.1μF/50V	CF93A1H104JT(JL)
C211	257 0014 935	Ceramic chip 0.1μF/25V	CK73F1E104ZT	C513,514	254 4524 985	Electrolytic 10μF/50V	CE04W1H100MT
C212	257 0010 900	Ceramic chip 0.01μF/50V	CK73B1H103KT	C515,516	257 0002 921	Ceramic chip 10pF/50V	CC73C1H100DT
C213-215			OPEN(CHIP C)	C517	254 4536 931	Electrolytic 330μF/10V	CE04W1A331MT
C216	257 0014 935	Ceramic chip 0.1μF/25V	CK73F1E104ZT	C599	254 3056 917	Electrolytic 1μF/50V(BP)	CE04D1H010MBPT
C301,302	257 0006 927	Ceramic chip 470pF/50V	CC73C1H471JT	C601	257 0008 983	Ceramic chip 1000pF/50V	CK73B1H102JT
C303,304	254 4524 972	Electrolytic 4.7μF/50V	CE04W1H4R7MT	C602	254 4536 915	Electrolytic 47μF/10V	CE04W1A470MT
C305,306	257 0006 927	Ceramic chip 470pF/50V	CC73C1H471JT	C603	257 0012 966	Ceramic chip 0.01μF/50V	CK73F1H103ZT
C307,308	254 4524 972	Electrolytic 4.7μF/50V	CE04W1H4R7MT	C604	257 0008 983	Ceramic chip 1000pF/50V	CK73B1H102JT
C309,310	257 0006 927	Ceramic chip 470pF/50V	CC73C1H471JT	C605	257 0012 966	Ceramic chip 0.01μF/50V	CK73F1H103ZT
C311,312	254 4524 972	Electrolytic 4.7μF/50V	CE04W1H4R7MT	C606	254 4538 900	Electrolytic 10μF/16V	CE04W1C100MT
C313,314	257 0006 927	Ceramic chip 470pF/50V	CC73C1H471JT	C607	257 0012 966	Ceramic chip 0.01μF/50V	CK73F1H103ZT
C315,316	254 4524 972	Electrolytic 4.7μF/50V	CE04W1H4R7MT	C608	254 4524 943	Electrolytic 1μF/50V	CE04W1H010MT
C317,318	257 0008 983	Ceramic chip 1000pF/50V	CK73B1H102JT	C609	254 4538 900	Electrolytic 10μF/16V	CE04W1C100MT
C319,320	254 4524 972	Electrolytic 4.7μF/50V	CE04W1H4R7MT	C610	257 0012 966	Ceramic chip 0.01μF/50V	CK73F1H103ZT
C321-323	257 0012 966	Ceramic chip 0.01μF/50V	CK73F1H103ZT				

Ref. No.	Part No.	Part Name	Remarks	Ref. No.	Part No.	Part Name	Remarks	Q'ty
C611	254 4524 943	Electrolytic 1μF/50V	CE04W1H010MT	CY152	951 0014 901	15P FFC base	IMSA-9604S-15A	1
C612		Electrolytic 4700μF/35V	CE04W1V472MC	CY191	951 0015 007	19P FFC base	IMSA-9604S-19F	1
C613	257 0012 966	Ceramic chip 0.01μF/50V	CK73F1H103ZT	CY211	951 0014 804	21P FFC base(1mm)	IMSA-9610S-21E	1
C614		Ceramic chip 4700pF/250V	CK45F2EAC472M	CY241	951 0013 504	24P FFC base	IMSA-9604S-24F	1
C615	257 0012 966	Ceramic chip 0.01μF/50V	CK73F1H103ZT	CY261	951 0014 503	26P connector base	IMSA-9142B-26A	1
C616	254 4541 939	Electrolytic 47μF/25V	CE04W1E470MT	CY262	951 0014 406	26P connector base	IMSA-9890S-26A	1
C617,618		Electrolytic 4700μF/35V	CE04W1V472MC					
C619,620	257 0012 966	Ceramic chip 0.01μF/50V	CK73F1H103ZT	Δ F601	206 1074 073	Fuse T500mA/250V	for E1,E2,EK	1
C621	254 4538 900	Electrolytic 10μF/16V	CE04W1C100MT	Δ F601	206 1072 033	Fuse 2A/125V	for E3	1
C622	257 0012 966	Ceramic chip 0.01μF/50V	CK73F1H103ZT	Δ F602	206 1072 043	Fuse T2.5A/250V	for E1,E2,EK	1
C623	254 4524 943	Electrolytic 1μF/50V	CE04W1H010MT	Δ F602	206 1072 088	Fuse 5A/125V	for E3	1
C624,625	257 0012 966	Ceramic chip 0.01μF/50V	CK73F1H103ZT					
C626	254 4524 985	Electrolytic 10μF/50V	CE04W1H100MT	FL401	393 8049 004	FL tube		1
C627	254 4525 926	Electrolytic 100μF/50V	CE04W1H101MT					
C628	257 0012 966	Ceramic chip 0.01μF/50V	CK73F1H103ZT	JK301	951 0010 604	4P RCA jack board		1
C629	257 0013 907	Ceramic chip 0.047μF/50V	CK73F1H473ZT	JK302	951 0010 701	6P RCA jack board		1
C630	254 4538 900	Electrolytic 10μF/16V	CE04W1C100MT	JK401	951 0010 507	Mini jack		1
C631	257 0012 966	Ceramic chip 0.01μF/50V	CK73F1H103ZT	JK408	951 0009 903	SP terminal		1
C632	254 4524 943	Electrolytic 1μF/50V	CE04W1H010MT	JK601	951 0010 808	Mini jack		1
C633	254 4403 721	Electrolytic 2200μF/25V	CE04W1E222MC	JK602	951 0010 808	Mini jack		1
C634,635	257 0012 966	Ceramic chip 0.01μF/50V	CK73F1H103ZT	Δ JK605	203 3961 004	AC outlet(E2)	for E1,E2,EK	1
C636-640			OPEN(CHIP C)	Δ JK605	951 0031 104	AC outlet(E3)	for E3	1
C701,702	257 0012 966	Ceramic chip 0.01μF/50V	CK73F1H103ZT	Δ IC902	206 1081 008	Fuse(SSFR1.0A F006)	MICRO FUSE 1A/125V	1
C703,704	255 1265 936	Poly film 0.01μF/50V	CQ93M1H103JT(B)					
C901,902		Ceramic 1000pF/50V	CK45B1H102KT	L101	214 0206 005	Inductor 10μH		1
				L501,502	235 0104 007	Inductor 1μH		2
				RL601	214 0206 005	Relay PCI-212DM		1
				RL602	214 0202 009	Power relay DG1U TV-8		1
				S402	951 0010 905	Tact switch		1
				S403	951 0010 905	Tact switch		1
				S405	951 0010 905	Tact switch		1
				S406	951 0010 905	Tact switch		1
				S407	951 0010 905	Tact switch		1
				S409	951 0010 905	Tact switch		1
				S410	951 0010 905	Tact switch		1
				S411	951 0010 905	Tact switch		1
				S412	951 0010 905	Tact switch		1
				S413	951 0011 302	Rotaly encorder	VOLUME	1
				SW301	951 0011 108	Slide switch	PRE OUT SW	1
				Δ T601	951 0011 001	Sub trans	for E1,E2,EK	1
				Δ T601	233 6355 003	Power trans(sub) E3	for E3	1
				X101	GP3 8002 050	Crystal 16.9344MHz		1
				X201	951 0011 700	Ceramic 12.5 MHz		1
				X301	951 0011 603	Crystal 4.332MHz		1
				★	951 0031 447	Micro fuse label 1A/125V (IC902)		

Ref. No.	Part No.	Part Name	Remarks	Q'ty
★	951 9002 079	Fuse label T500mA/250V (F601)	for E1,E2,EK	1
★	951 0031 450	Fuse label 2A/125V (F601)	for E3	1
★	951 9002 066	Fuse label T2.5A/250V (F602)	for E1,E2,EK	1
★	951 0031 421	Fuse label 5A/125V (F602)	for E3	1
★	417 0253 055	Radiator	for IC604	1
★	417 0253 013	Radiator	for IC603	1
★	951 9001 177	Screw 3X6 CBRTS		5
★	951 0015 201	2P SAN-SAN connector cord	CW021	1
★	951 0015 706	4P PH-SAN connector cord	CX042	0
★	951 0052 609	3P PH-SAN connector cord	CX035	1
★	951 0015 502	5P PH-PH connector cord	CX051	1
★	951 0015 405	6P PH-PH connector cord	CX061	1
★	951 0015 308	15P PH-PH connector cord	CX151	1
★	951 0015 803	15P FFC cable	CY152	1
★	951 0016 103	16P FFC cable	CX161	1
★	951 0015 900	19P FFC cable	CX191	1
★	951 0016 200	21P FFC cable	CX211	1
★	951 0016 006	24P FFC cable	CX241	1
★	202 0040 909	Fuse holder	F601,602	4
★	449 0172 007	Senser holder		1
★	461 1067 001	FL spacer		2
★	—	1P wire Ass'y	W705	1
★	—	1P wire Ass'y	W716	1
★	—	1P wire	W711A-W711B	1
★	—	1P wire	W712A-W712B	1
★	—	1P wire	W713A-W713B	1
★	—	1P wire	W714A-W714B	1
★	—	1P wire	W901	1
★	—	1P wire	W717 for E2,EK	1

PARTS LIST OF EXPLODED VIEW

Ref. No.	Part No.	Part Name	Remarks	Q'ty	Ref. No.	Part No.	Part Name	Remarks	Q'ty
1	951 0009 411	MAIN P.W.B. unit Ass'y	For E2,EK	1s	36	951 9002 053	Spring plate		5
1	951 0009 424	MAIN P.W.B. unit Ass'y	For E3	1s	37	951 0033 102	Earth plate		1
1	951 0009 437	MAIN P.W.B. unit Ass'y	For E1	1s	38	951 9002 037	Insulator washer		1
1-1		POWER P.W.B. unit			★	951 0016 200	FFC cable		1
1-2		AMP-1 P.W.B. unit							
1-3		AMP-2 P.W.B. unit							
1-4		DISPLAY P.W.B. unit							
1-5		SPEAKER P.W.B. unit							
1-6		CD P.W.B. unit							
1-7		I/O P.W.B. unit							
1-8		μ-CON P.W.B. unit							
1-9		JUNCTION P.W.B. unit							
2	144 2717 002	Front panel	For E2,EK	1	SCREWS				
2	144 2717 015	Front panel	For E3	1	101	473 7015 005	Screw 3×6 CBTS(S)-B		17
2	144 2717 015	Front panel	For E1	1	102	951 9001 070	Screw 3×6 CBTS(S)-Z		4
3	146 2196 001	Inner panel		1	103	951 9001 180	Screw 3×8 CBTS(P)-B		12
4	143 1087 002	FL window		1	104	951 9001 151	Screw 3×8 CBTS(P)-Z		18
5	146 2202 005	Knob cap (A)		3	105	951 9001 193	Screw 3×14 CBTS(P)-Z		5
6	146 2203 004	Knob cap (B)		5	106	951 9001 164	9 Nut		1
7	114 0152 008	Knob ring (3P)		1	107	GP3 8009 026	Screw 3×25 CBTS(S)-Z		2
8	143 1086 003	Remocon filter		1	108	951 9002 011	Screw 3×35 CBTS(S)-Z		2
9	113 1888 006	Power knob Ass'y		1	109	473 7004 016	Screw 4×6 CBTS(S)-Ni		4
10	112 0856 007	Volume knob Ass'y		1	110	477 0263 018	3P Swelling screw		2
11	146 2199 008	Loader panel		1	111	473 7015 005	Screw 3×6 CBTS(S)-B		4
12	146 2201 006	Side esucutcheon		2	112	477 0096 007	Push rivet		1
13	411 1940 301	Chassis		1					
14	104 0317 008	Foot		4					
15	461 1066 002	Felt		4					
16	417 0596 000	Heat sink		1					
17	951 0016 501	Shield plate		2					
18	412 4621 002	Mecha holder		1					
19	337 0080 003	CD mecha unit		1					
20	105 1345 001	Rear plate	For E2,EK	1					
20	105 1345 014	Rear plate	For E1	1					
20	105 1345 030	Rear plate	For E3	1					
21	412 4622 001	PCB support (A)		1					
22	102 0633 003	Top cover		1					
△	233 6335 007	Power trans	For E2,EK,E1	1					
△	233 6334 006	Power trans	For E3	1					
△	951 0009 709	AC cord	For E2,EK,E1	1					
△	951 0026 201	AC cord	For E3	1					
△	951 0033 907	AC cord	For EK	1					
25	445 0056 008	Bushing		1					
26	216 0108 002	Tuner pack	For E2,EK,E1	1					
26	216 0109 001	Tuner pack	For E3	1					
27	443 9015 002	PWB spacer (H=8)		3					
28	412 2814 002	Card spacer (H=8)		2					
29	393 8049 004	FLD		1					
30	449 0172 007	Remote sencer holder		1					
31	415 0844 002	PVC sheet		1					
32	951 0033 209	PWB sheet		1					
33	951 0016 705	Fuse cover		1					
34	951 0016 909	Fuse cover (L)		1					

EXPLODED VIEW

1 2 3 4 5 6 7 8

WARNING:
Parts marked with this symbol  have critical characteristics.
Use **ONLY** replacement parts recommended by the manufacturer.

A
B
C
D
E

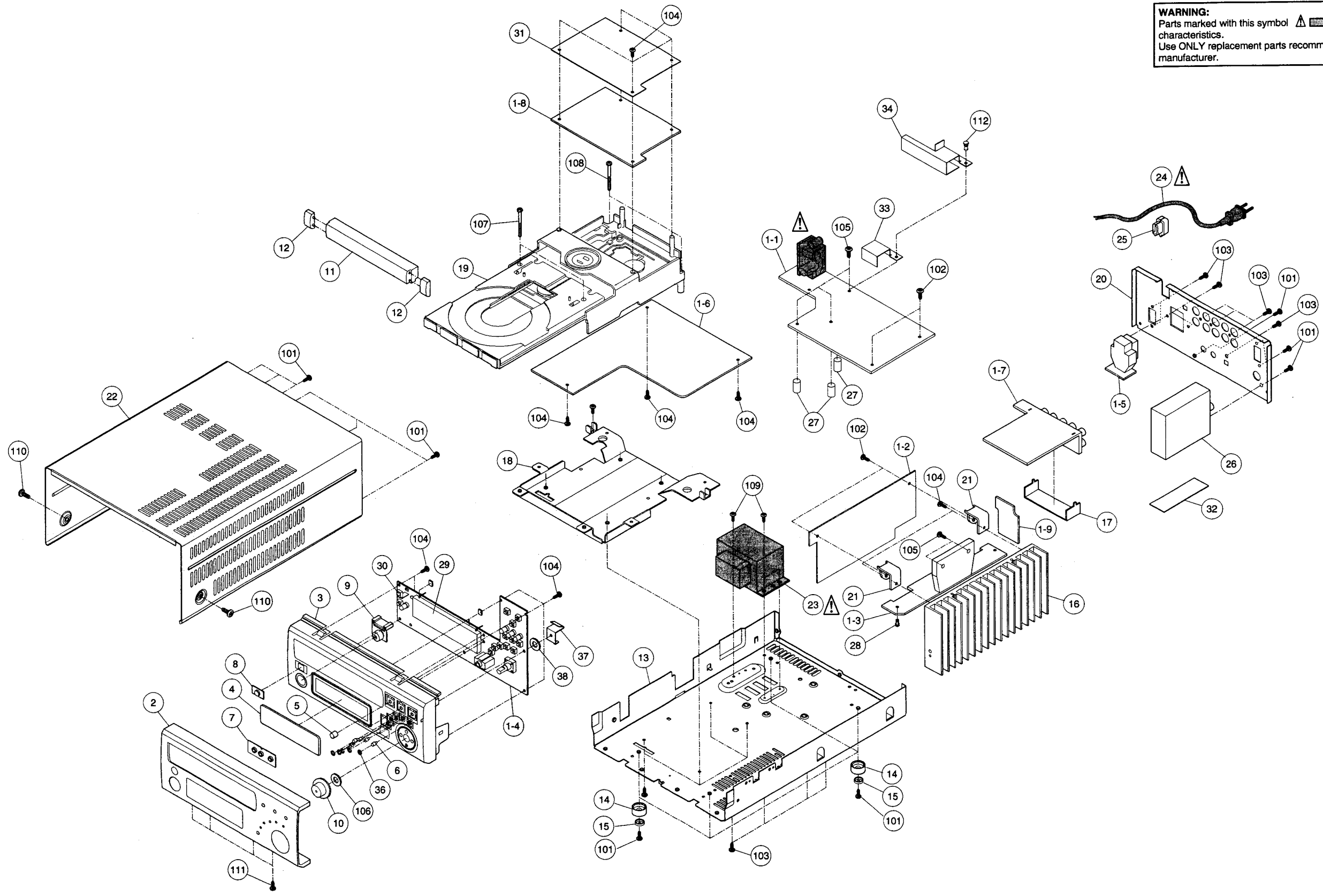

EXPLODED VIEW OF CD MECHANISM UNIT

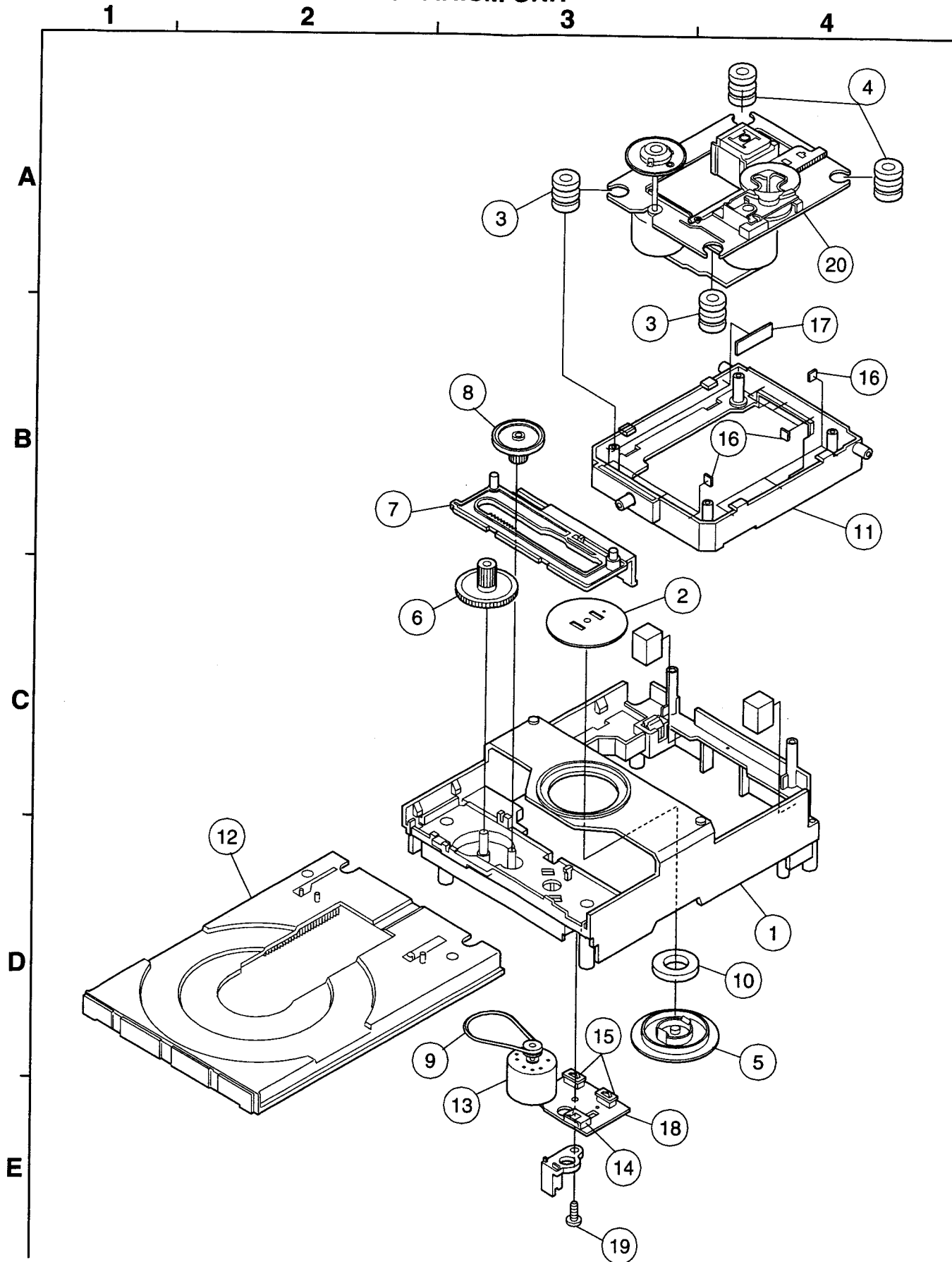

EXPLODED VIEW OF MECHANISM UNIT

Ref. No.	Part No.	Part Name	Remarks	Q'ty
1	964 0009 006	Frame chassis		1
2	964 0009 103	Magnet plate		1
3	964 0009 200	Rubber cushion		2
4	964 0009 307	Rubber cushion		2
5	964 0009 404	Magnet holder		1
6	964 0009 501	Drive gear		1
7	964 0009 608	Slide gear		1
8	964 0009 705	Pulley gear		1
9	964 0009 802	Square belt		1
10	964 0009 909	Magnet		1
11	964 0010 008	Mecha lifter		1
12	964 0010 105	Loading table ass'y		1
13		Loading motor		1
14	964 0010 202	5P Plug		1
15	964 0010 309	Push switch 2-1		2
16	964 0010 406	Cushion		9
17	964 0010 503	Cushion		2
18	964 0010 600	Motor P.W.B.		2
19	964 0010 707	Screw 3x8 SCR S-TPG BIN		1
20	964 0010 804	Mecha DA11T3C		1

Only the parts listed in the left table can be changed. Replace the Mecha. Unit if other parts than listed ones are to be repaired.

PACKING VIEW

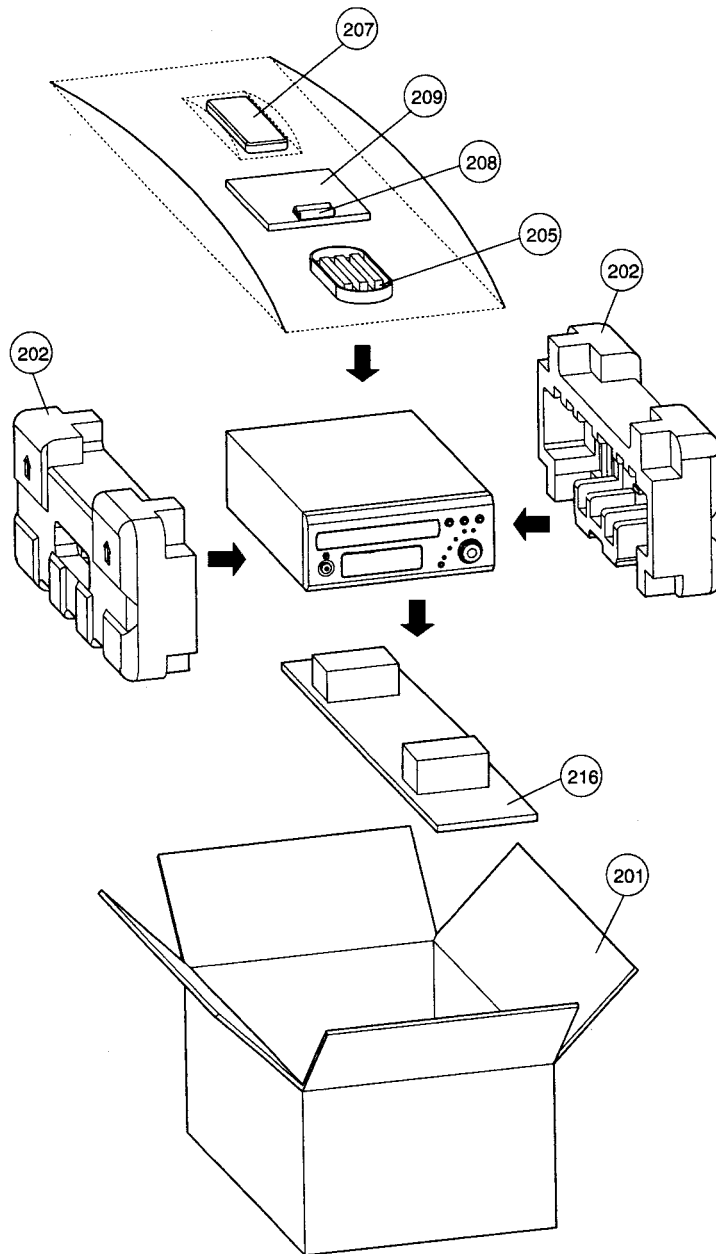

PARTS LIST OF PACKING & ACCESSORIES

Ref. No.	Part No.	Part Name	Remarks	Q'ty	Ref. No.	Part No.	Part Name	Remarks	Q'ty
201	501 2090 003	Carton case		1	210	515 0690 404	DEL Warranty home	E3 only	1
202	503 1358 001	Cushion		2	211	515 0867 004	Service list		1
203	951 0016 608	Poly cover		1	212	—	Control card	For E2,EK	1
204	505 0038 030	Envelope		1	212	—	Control card	For E3	1
205	951 0009 107	AM loop antenna		1	212	—	Control card	For E1	1
206	951 0009 301	FM antenna		1	213	—	Manufactured label	For E3	1
207	951 0009 000	Remote control		1	214	517 1431 008	POS label	For E2	1
208	—	Battery		2	214	517 1431 011	POS label	For EK	2
209	511 3651 008	Instruction manual	For E2,EK	1	215	517 1433 006	UPC label	For E3	1
209	511 3652 007	Instruction manual	For E3	1	216	—	Sub cushion		1
209	511 3650 009	Instruction manual	For E1	1					

MEMO:

SCHEMATIC DIAGRAMS (1/2)

1

2

3

4

5

6

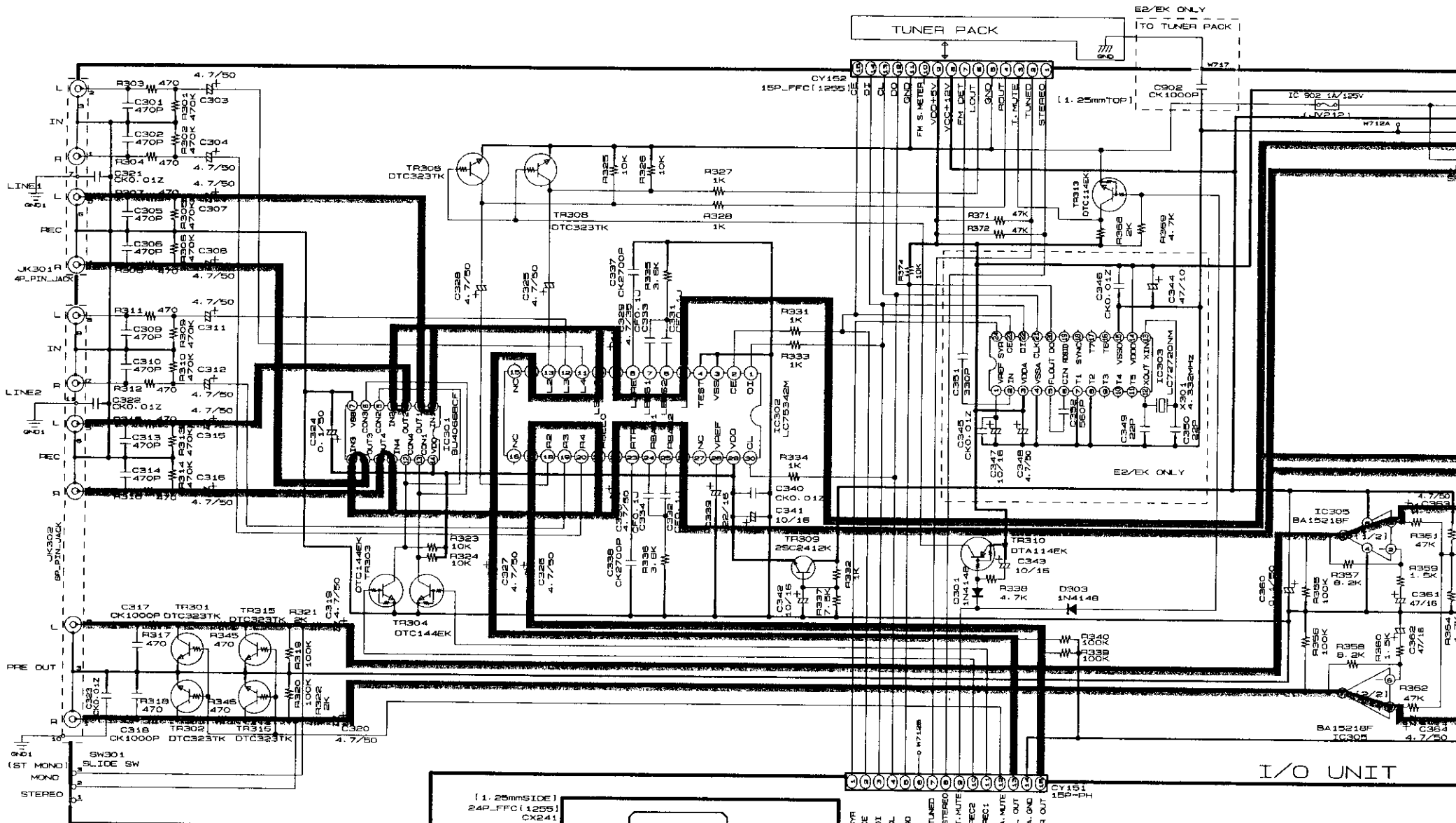

VERSION SELECT 0 = 4.7K

	R214	R215	R216	R217	R218	R219	R220	R221	R222
E2/EK	OPEN	OPEN	OPEN	OPEN	OPEN	OPEN	OPEN	OPEN	OPEN
E3	OPEN	OPEN	OPEN	OPEN	OPEN	OPEN	OPEN	OPEN	OPEN
E1	OPEN	OPEN	OPEN	OPEN	OPEN	OPEN	OPEN	OPEN	OPEN
J	OPEN	OPEN	OPEN	OPEN	OPEN	OPEN	OPEN	OPEN	OPEN

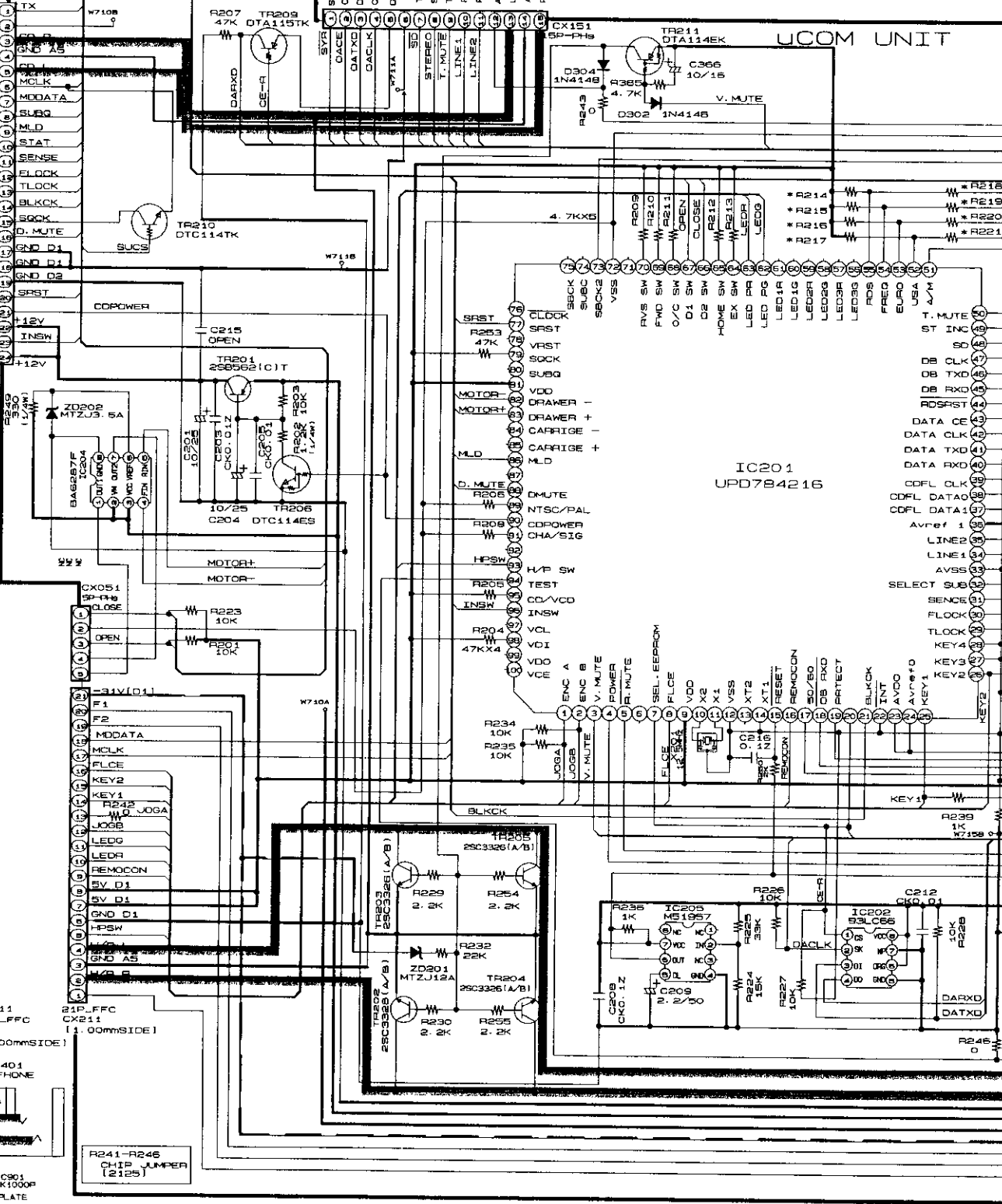
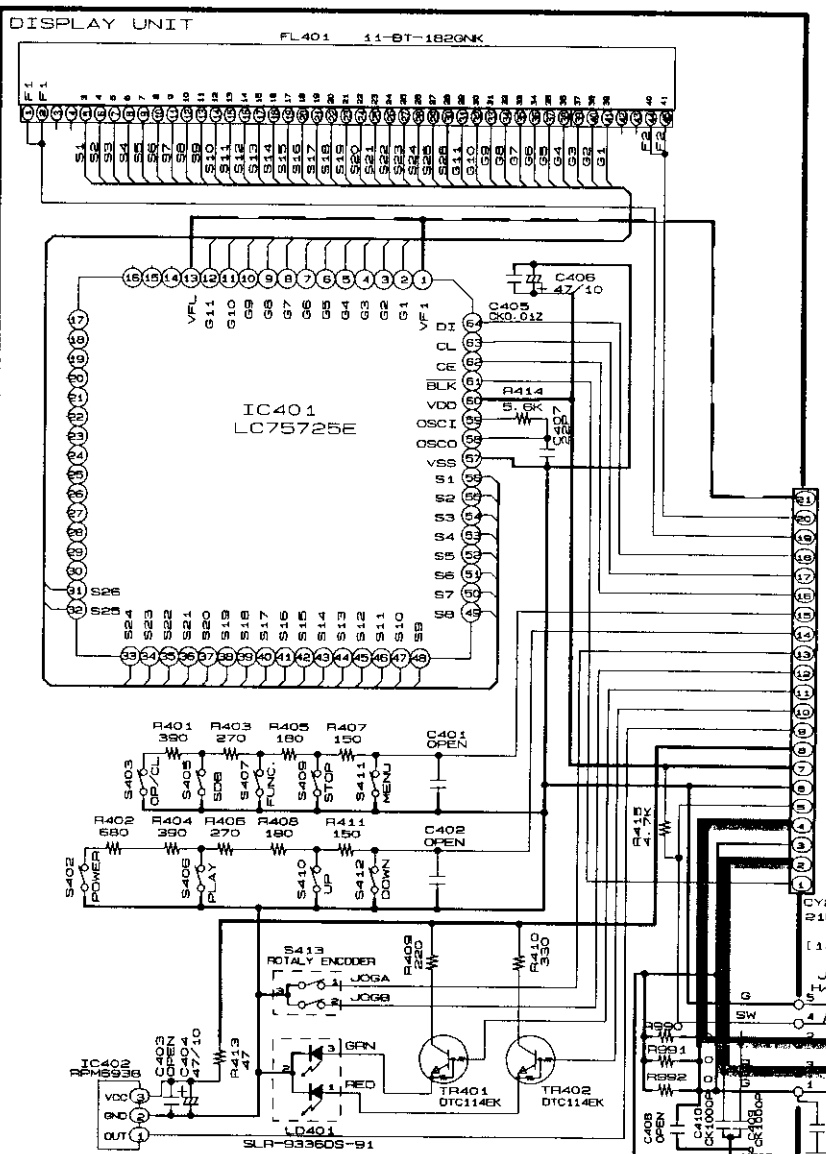

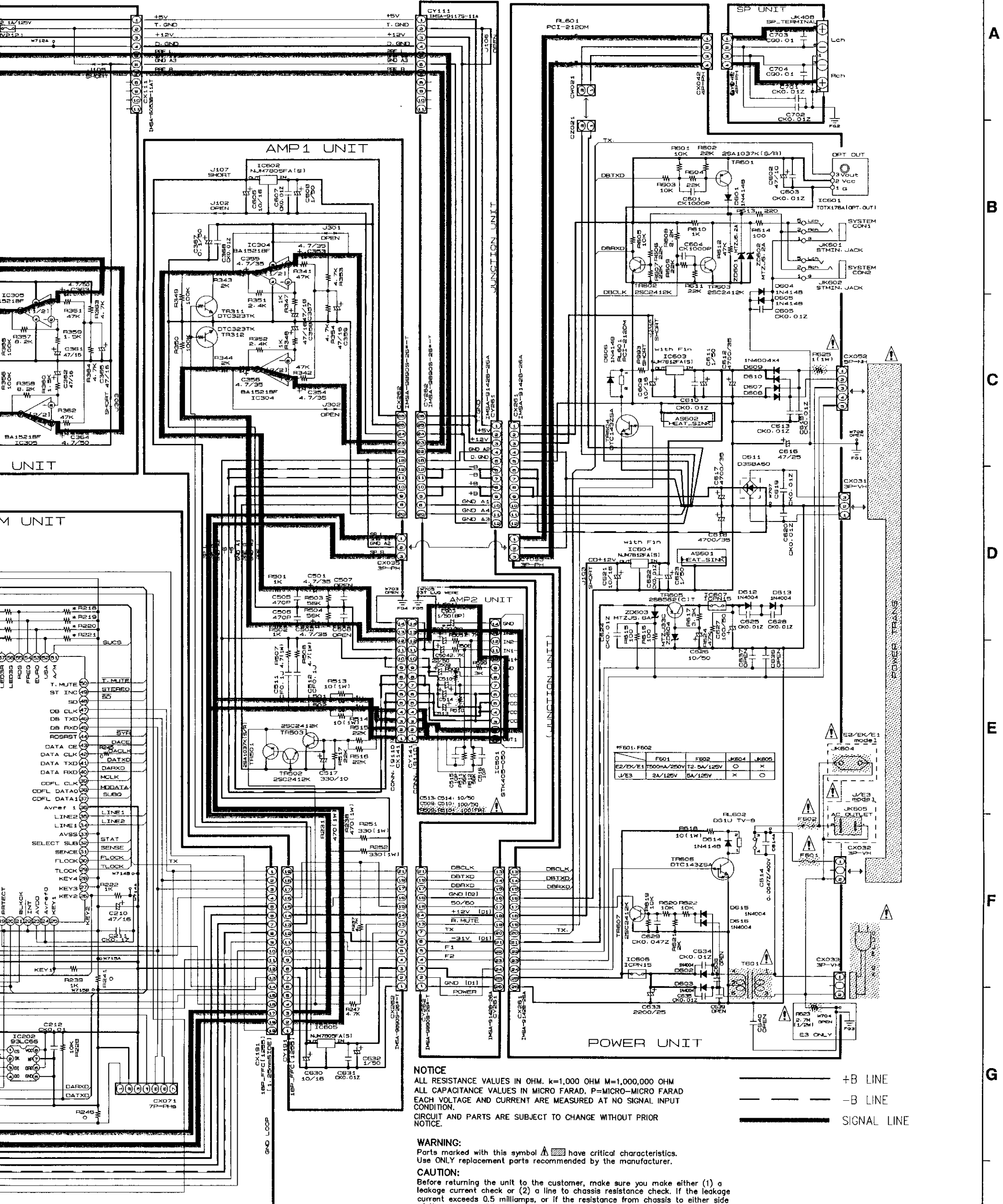

NOTICE
 ALL RESISTANCE VALUES IN OHM. k=1,000 OHM M=1,000,000 OHM
 ALL CAPACITANCE VALUES IN MICRO FARAD. P=MICRO-MICRO FARAD
 EACH VOLTAGE AND CURRENT ARE MEASURED AT NO SIGNAL INPUT CONDITION.
 CIRCUIT AND PARTS ARE SUBJECT TO CHANGE WITHOUT PRIOR NOTICE.

WARNING:
 Parts marked with this symbol have critical characteristics. Use ONLY replacement parts recommended by the manufacturer.

CAUTION:
 Before returning the unit to the customer, make sure you make either (1) a leakage current check or (2) a line to chassis resistance check. If the leakage current exceeds 0.5 millamps, or if the resistance from chassis to either side of the power cord is less than 460 kohms, the unit is defective.

WARNING:
 DO NOT return the unit to the customer until the problem is located and corrected.

— +B LINE
 - - - -B LINE
 ——— SIGNAL LINE

**SCHEMATIC DIAGRAMS (1/2)
 MAIN UNIT**

A
 B
 C
 D
 E
 F
 G
 H

SCHEMATIC DIAGRAMS (2/2)

1 2 3 4 5 6

A

B

C

D

E

F

G

H

CD MECHA

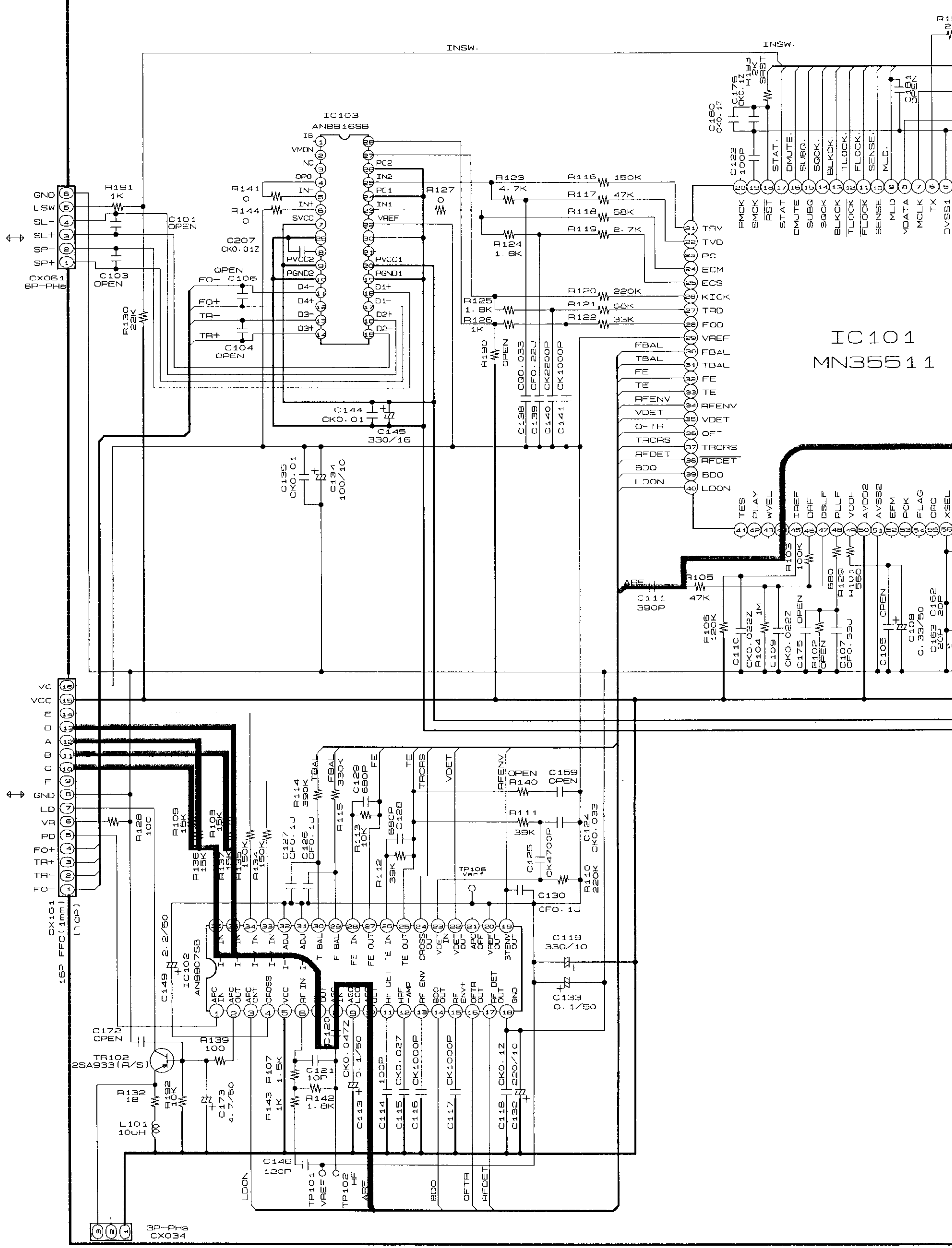

IC101
MN35511

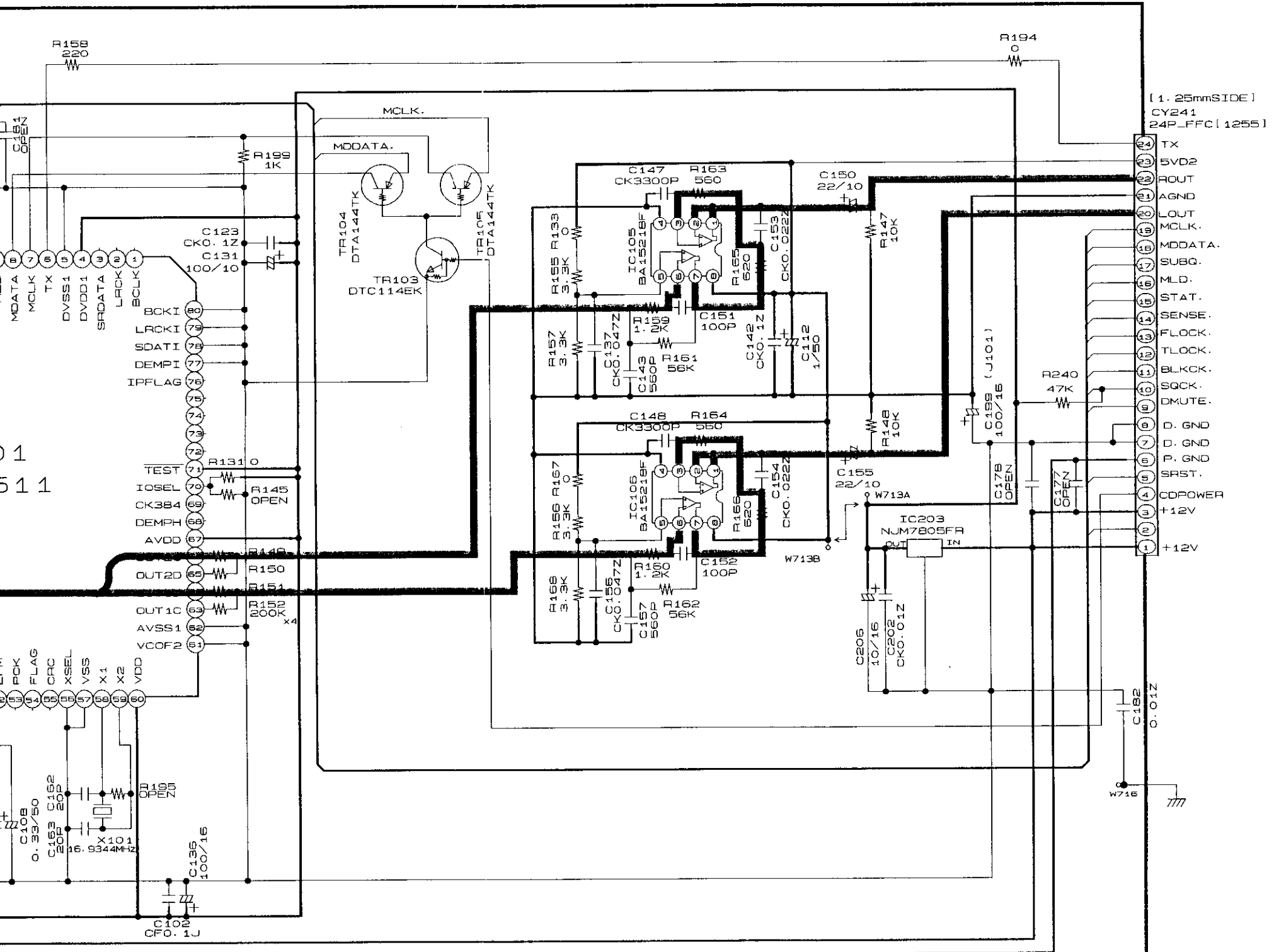

————— +B LINE
 ————— SIGNAL LINE