

DENON

Hi-Fi Personal Component System

SERVICE MANUAL

MODEL UD-M3

STEREO CD RECEIVER

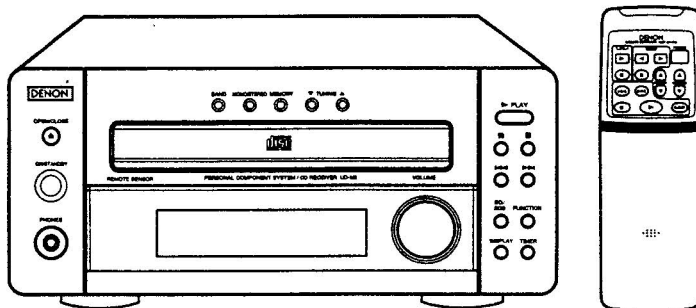

— CONTENTS —

SAFETY PRECAUTIONS	2
SPECIFICATIONS	2
DISASSEMBLY	3, 4
BLOCK, LEVEL DIAGRAM	5
CD MECHA BLOCK DIAGRAM	6
ADJUSTMENT	7
SEMICONDUCTORS	8-17
PRINTED WIRING BOARD	18, 19
NOTE FOR PARTS LIST	20
PARTS LIST OF P.W.B. UNIT	20-25
EXPLODED VIEW	26
PARTS LIST OF EXPLODED VIEW	27, 28
EXPLODED VIEW OF CD MECHANISM UNIT	29
PARTS LIST CD MECHANISM UNIT	29
WIRING DIAGRAM	30
SCHEMATIC DIAGRAM	31-32

● Some illustrations using in this service manual are slightly different from the actual set.

NIPPON COLUMBIA CO., LTD.

SAFETY PRECAUTIONS

The following check should be performed for the continued protection of the customer and service technician.

LEAKAGE CURRENT CHECK

Before returning the unit to the customer, make sure you make either (1) a leakage current check or (2) a line to chassis resistance check. If the leakage current exceeds 0.5 milliamps, or if the resistance from chassis to either side of the power cord is less than 460 kohms, the unit is defective.

SPECIFICATIONS

● Receiver section

Reception frequency band:	FM: 87.50 MHz – 108.00 MHz AM: 522 kHz – 1611 kHz Europe, U.K. & Asia models AM: 520 kHz – 1710 kHz U.S.A. & Canada models
Reception sensitivity:	FM: 1.5 μ V / 75 Ω / ohms AM: 20 μ V
FM stereo separation:	35 dB (1 kHz)
Rated output power:	20 W + 20 W (6 Ω / ohms, 1 kHz, T.H.D. 10 %)
Audio input / output jacks:	TAPE input / output jacks, AUX input jacks, MD input / output jacks, PRE OUT (MONO) jack, 3.5 mm headphones jack

● CD player section

Wow & flutter:	Below measurable limits (\pm 0.001 % W.peak)
Sampling frequency:	44.1 kHz
Optical source:	Semiconductor

● General

Power supply:	AC 120 V, 60 Hz U.S.A. & Canada models AC 230 V, 50 Hz Europe, U.K. & Asia models
Power consumption:	55 W
Maximum external dimensions:	210 (W) \times 95 (H) \times 337 (D) mm (8-17/64" \times 3-45/64" \times 13-17/64") (including feet, controls and terminals)
Weight:	4.1 kg (9lbs. 1 oz)

● Remote control unit (RC846)

Remote control system:	infrared pulse
Number of buttons:	54
Power supply:	Two DC 1.5V R6P / AA batteries
Maximum external dimensions:	67 (W) \times 197 (H) \times 21 (D) mm (2-41/64" \times 7-3/4" \times 53/64")
Weight:	145 g (5.1 oz) (including batteries)

● Maximum dimensions include controls, jacks, and covers.

(W) = width, (H) = height, (D) = depth

● For improvement purposes, specifications and functions are subject to change without advanced notice.

DISASSEMBLY

(Follow the procedure below in reverse order when reassembling)

Top Cover

1. Remove 2 screws ① on both sides.
2. Remove 5 screws ② on the rear.
3. Detach the Top Cover in the arrow direction.

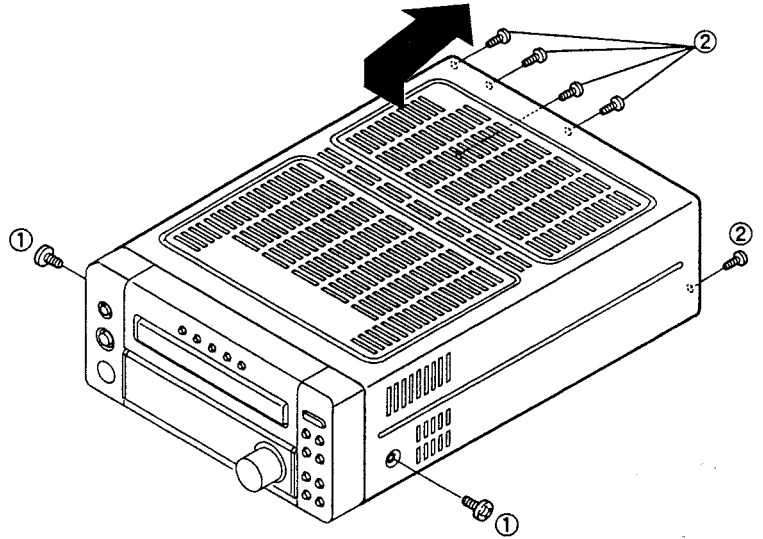

Front Panel

1. Remove 4 screws ③ on the bottom edge of the Front Panel.
2. Remove 2 screws ④ on both sides.
3. Disconnect FFC and connector from Main P.W.B.

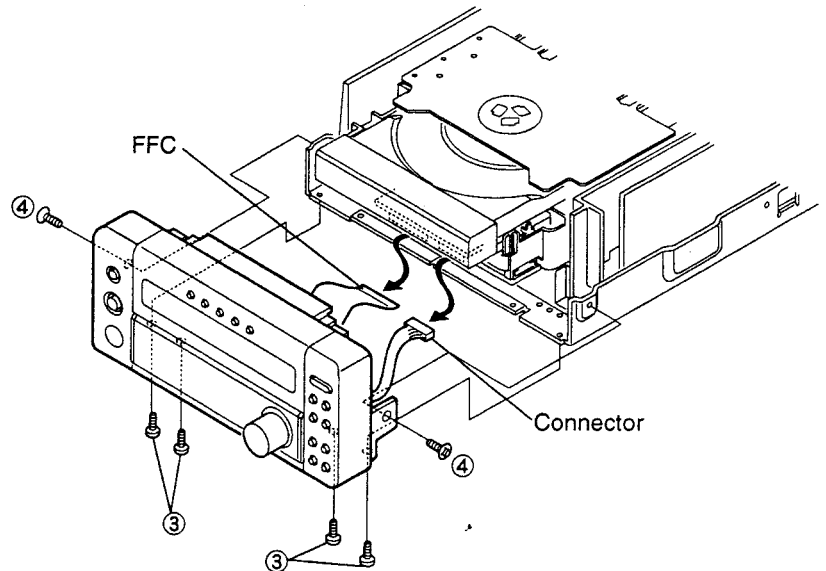

CD Mecha.

1. Disconnect connector coming out of Tuner/CD P.W.B.
2. Disconnect FFC cable coming out of the CD Mecha.
3. Remove 4 screws ⑤ fixing the CD Mecha.

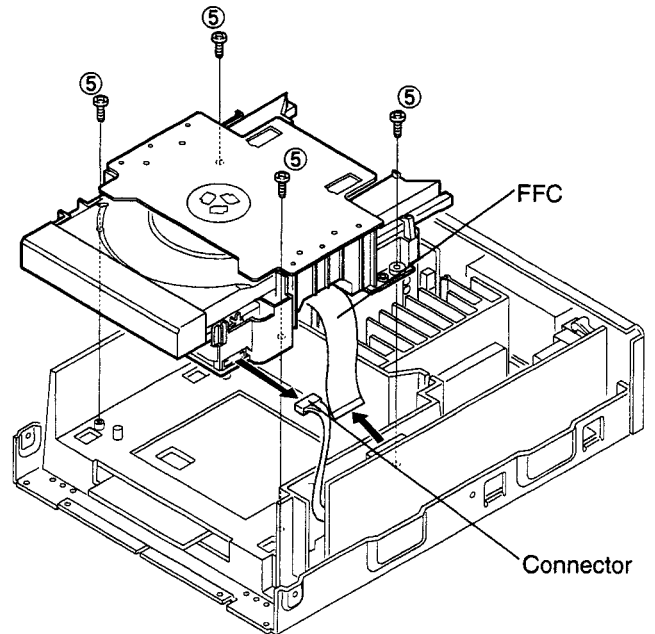

Rear Panel

1. Take off cord bush from the Rear Panel.
2. Remove 4 screws ⑥.

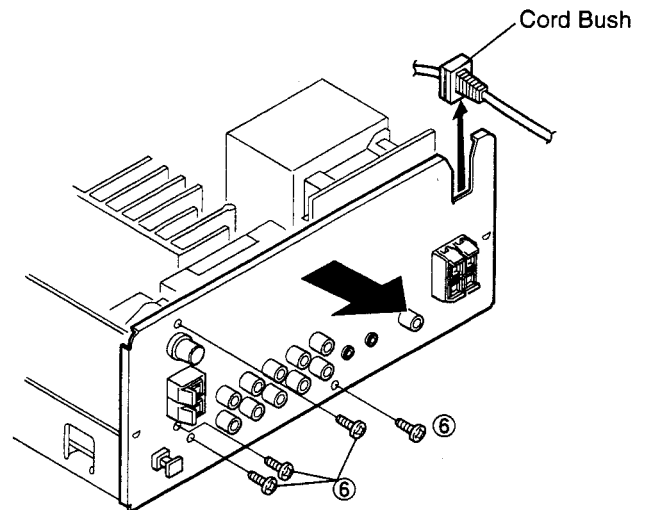

Main P.W.B.

1. Remove screw ⑦ fixing the earth wire.
2. Remove 3 screws ⑧ fixing the P.W.B. at side.
3. Remove 5 screws ⑨, then detach the Main P.W.B. and mecha. bracket.

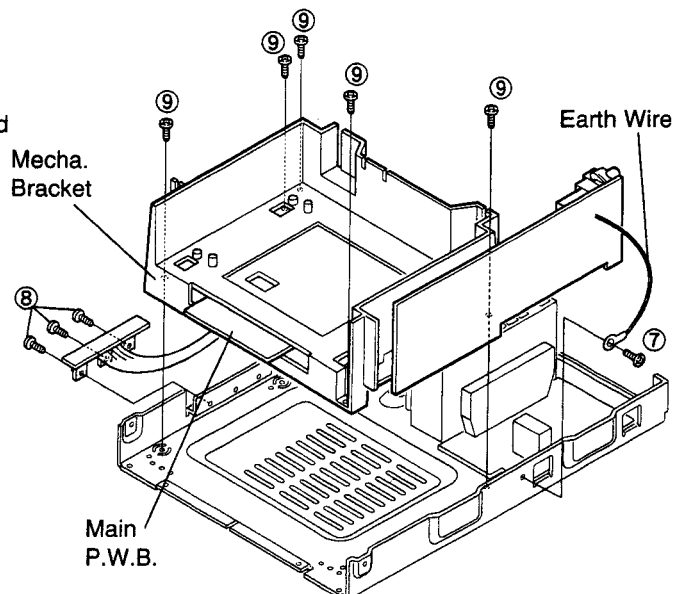

BLOCK, LEVEL DIAGRAM

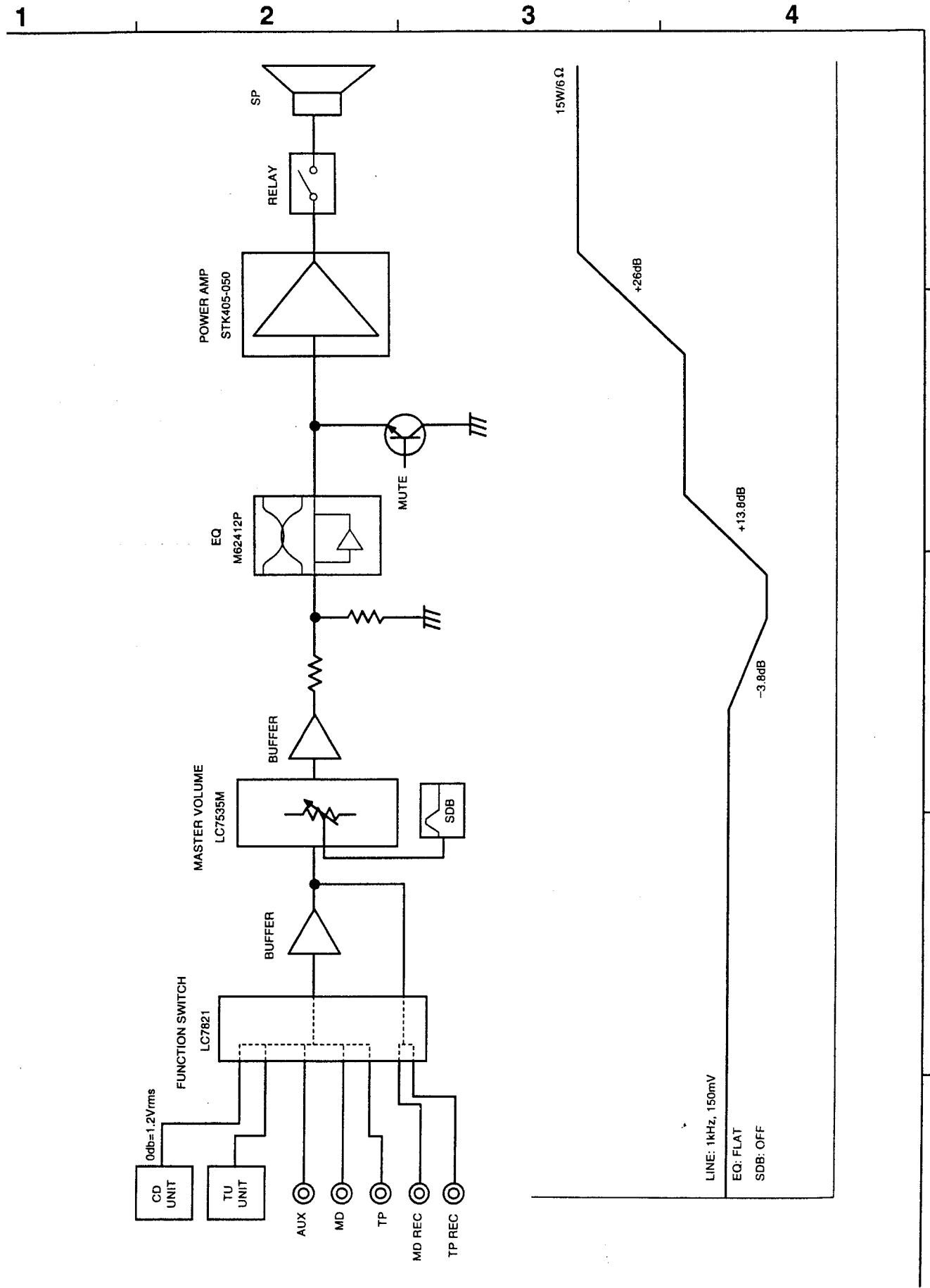

ADJUSTMENT

1. TUNER adjustment (BAND button: FM, MONO/AUTO button: AUTO)

Adjustment item	Tuning point (channel setting)	Input					Output		Adjustment location	Setting value	Notes
		Measuring Instrument	Frequency	Input level	Modulation	Connection location	Measuring instrument	Connection location			
FM DC balance	98.00MHz	FM S.G.	98.00MHz	60dB μ	1kHz 75kHz DEV	FM antenna terminal	DC balance meter	⊕ CN201 ⊖ CN201	T202	0 \pm 30mV	Perform with monaural modulation signal

WIRING/ADJUSTING POINTS

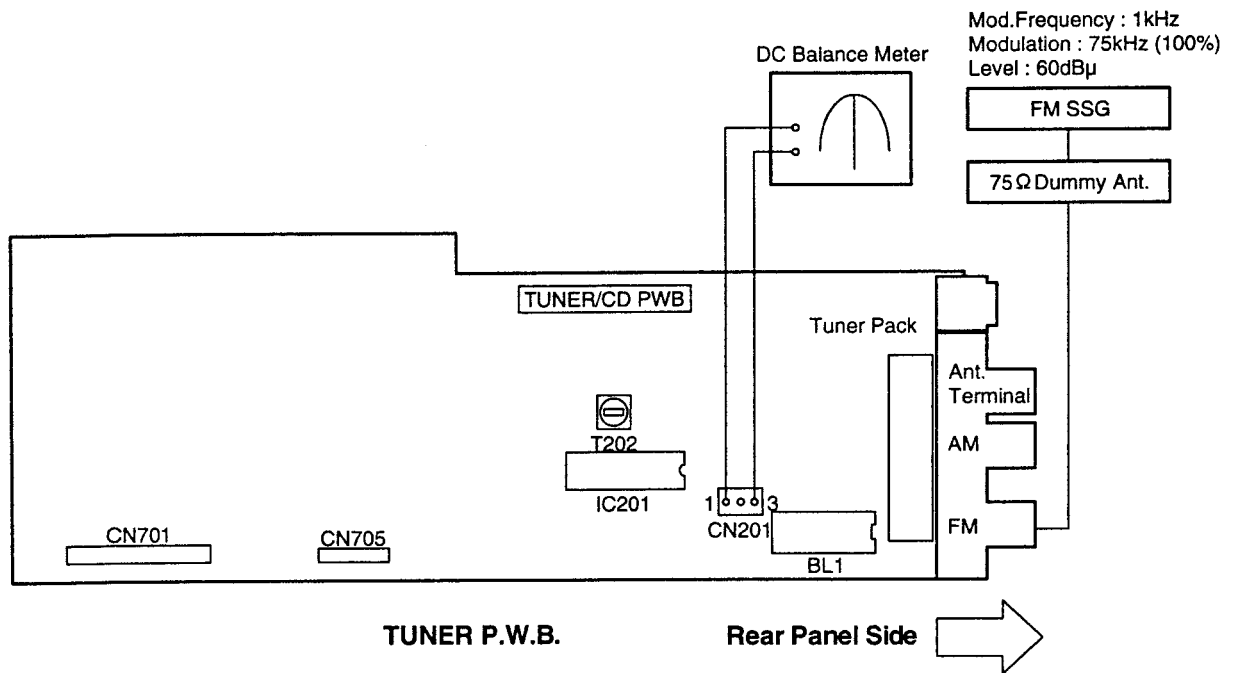

DATA OF MICROPROCESSOR

μPD780208GF-026-3BA

Except U.S.A./Canada model

μPD780208GF-028-3BA

U.S.A./Canada model

(IC601)

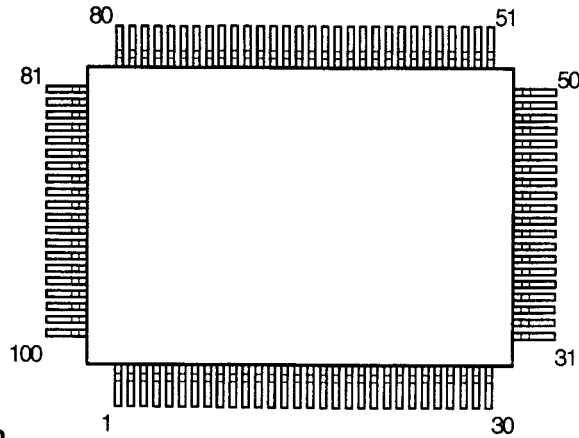

● μPD780208 (IC601) Terminal Function

Pin No.	Port	Symbol	I/O	Det	Res	Ext	Act	INT	MO	Function
1	VDD	VDD	—	—	—	—	—	—	—	Positive power
2	P37	FL_DATA7	I	Lv	Z	Pd	—	L	—	FL display data input (bit 7)
3	P36/BUZ	FL_DATA6	I	Lv	Z	Pd	—	L	—	FL display data input (bit 6)
4	P35/PCL	FL_DATA5	I	Lv	Z	Pd	—	L	—	FL display data input (bit 5)
5	P34/TI2	FL_DATA4	I	Lv	Z	Pd	—	L	—	FL display data input (bit 4)
6	P33/TI1	FL_DATA3	I	Lv	Z	Pd	—	L	—	FL display data input (bit 3)
7	P32/TO2	FL_DATA2	I	Lv	Z	Pd	—	L	—	FL display data input (bit 2)
8	P31/TO1	FL_DATA1	I	Lv	Z	Pd	—	L	—	FL display data input (bit 1)
9	P30/TO0	FL_DATA0	I	Lv	Z	Pd	—	L	—	FL display data input (bit 0)
10	RESET	RESET	—	—	—	—	L	—	—	μcom reset input
11	X2	X2	I	—	—	—	—	—	—	X'tal connection for main clock oscillation
12	X1	X1	—	—	—	—	—	—	—	X'tal connection for main clock oscillation
13	IC	IC	—	—	—	—	—	—	—	Internal connection to Vss
14	XT2	XT2	I	—	—	—	—	—	—	X'tal connection for sub-clock oscillation, not used: NC
15	P04/XT1	P04/XT1	—	—	Z	—	—	—	—	X'tal connection for sub-clock oscillation, not used: Connect to Vss or VDD
16	VDD	VDD	I	—	—	—	—	—	—	Positive power
17	P27/SCK0	DB_CLK	O	—	Z	—	—	H	—	DENON BUS clock output
18	P26/SO0/SB1	DB_TXD	O	—	Z	—	—	H	—	DENON BUS data output
19	P25/SI0/SB0	DB_RXD	I	Ed	Z	—	—	—	—	DENON BUS data input
20	P24/BUSY	RDSRST	O	—	Z	—	L	H	—	RDS IC reset output
21	P23/SIB	DATA_CE	O	—	Z	—	H	L	—	Data bus (for PLL, VOL, RDS IC) chip enable output
22	P22/SCK1	DATA_CLK	O	—	Z	—	—	H	—	Data bus (for PLL, VOL, RDS IC) clock output
23	P21/SO1	DATA_TXD	O	—	Z	—	—	H	—	Data bus (for PLL, VOL, RDS IC) data output
24	P20/SI1	DATA_RXD	I	Ed	Z	—	—	—	—	Data bus (for PLL, VOL, RDS IC) data input
25	AVSS	AVSS	—	—	—	—	—	—	—	A/D converter GND potential
26	P17/AN7	FL_REQ	I	Lv	Z	—	L	—	—	FL display request input
27	P16/AN6	FL_CE	O	—	Z	—	—	H	—	FL display chip enable output
28	P15/AN5	FL_EN	I	Lv	Z	—	—	—	—	FL display data enable input
29	P14/AN4	WAKEUP	I	Lv	Z	—	H	L	—	Power on request signal from CD
30	P13/AN3	SEL. EEPROM	O	—	Z	—	H	L	—	EEPROM chip enable output
31	P12/AN2	F_CD	O	—	Z	—	H	—	—	Function CD output
32	P11/AN1	KEY2	I	A	Z	Pu	—	—	—	Unit operation button input 2
33	P10/AN0	KEY1	I	A	Z	Pu	—	—	—	Unit operation button input 1
34	AVDD	AVDD	—	—	—	—	—	—	—	A/D converter analog power
35	AVref	AVREF	I	—	—	—	—	—	—	A/D converter ref. V input
36	P03/INIP3	PROTECT	I	Ed	Z	Pu	L	—	—	SP terminal DC voltage detect signal input
37	P02/INIP2	DB_RXD	I	Ed	Z	—	L	—	—	DENON BUS data input (interrupt input)
38	P01/INIP1	50/60	I	Ed	Z	—	L	—	—	50/60 Hz AC input
39	P00/INIP0/II	REMCN	I	Ed	Z	—	—	—	—	Remo-con. receive data input
40	Vss	VSS	—	—	—	—	—	—	—	GND potential
41	P74	---	O	—	Z	—	—	—	N	Not used
42	P73	---	O	—	Z	—	—	—	N	Not used

Pin No.	Port	Symbol	I/O	Det	Res	Ext	Act	INT	MO	Function
43	P72	EQ1	O	—	Z	Pu	—	—	N	Graph-eq. IC switching signal output
44	P71	EQ2	O	—	Z	Pu	—	—	N	Graph-eq. IC switching signal output
45	P70	TMUTE	O	—	Z	Pu	L	—	N	Tuner mute output, mute on: Lo
46	VDD	VDD	—	—	—	—	—	—	N	Positive power
47	P127/FIP52	ENC_A	I	Lv	Z	Pu	—	—	N	Rotary encoder input
48	P126/FIP51	ENC_B	I	Lv	Z	Pu	—	—	N	Rotary encoder input
49	P125/FIP50	---	O	—	Z	—	—	—	N	Not used
50	P124/FIP49	---	O	—	Z	—	—	—	N	Not used
51	P123/FIP48	---	O	—	Z	—	—	—	N	Not used
52	P122/FIP47	---	O	—	Z	—	—	—	N	Not used
53	P121/FIP46	SD	I	Lv	Z	Pu	L	—	N	FM/AM tuning signal input, tuned: Lo
54	P120/FIP45	ST IND	I	Lv	Z	Pu	L	—	N	FM stereo demodulation detect input, stereo: Lo
55	P117/FIP44	USA	I	Lv	Z	—	—	—	N	Initial setting input
56	P116/FIP43	EUR	I	Lv	Z	—	—	—	N	Initial setting input
57	P115/FIP42	FREQ	I	Lv	Z	—	—	—	N	Initial setting input
58	P114/FIP41	RDS	I	Lv	Z	—	—	—	N	Initial setting input
59	P113/FIP40	---	O	—	Z	—	—	—	N	Not used
60	P112/FIP39	---	O	—	Z	—	—	—	N	Not used
61	P111/FIP38	---	O	—	Z	—	—	—	N	Not used
62	P110/FIP37	---	O	—	Z	—	—	—	N	Not used
63	P107/FIP36	---	O	—	Z	—	—	—	N	Not used
64	P106/FIP35	---	O	—	Z	—	—	—	N	Not used
65	P105/FIP34	---	O	—	Z	—	—	—	N	Not used
66	P104/FIP33	---	O	—	Z	—	—	—	N	Not used
67	P103/FIP32	V. MUTE	O	—	Z	Pd	H	H	N	Volume mute output, mute: Hi
68	P102/FIP31	POWER	O	—	Z	Pd	L	L	N	Amp circuit power on/off output, on: Lo
69	P101/FIP30	AUTO/MONO	O	—	Z	—	—	—	N	FM AUTO/MONO switching, MONO: Hi
70	P100/FIP29	RMUTE	O	—	Z	Pd	L	L	N	Speaker relay on/off output, on:
71	P97/FIP28	---	O	—	Z	—	—	—	N	Not used
72	P96/FIP27	SEG1	O	—	Z	Pd	—	—	N	Segment output 1
73	P95/FIP26	SEG2	O	—	Z	Pd	—	—	N	Segment output 2
74	P94/FIP25	SEG3	O	—	Z	Pd	—	—	N	Segment output 3
75	P93/FIP24	SEG4	O	—	Z	Pd	—	—	N	Segment output 4
76	P92/FIP23	SEG5	O	—	Z	Pd	—	—	N	Segment output 5
77	P91/FIP22	SEG6	O	—	Z	Pd	—	—	N	Segment output 6
78	P90/FIP21	SEG7	O	—	Z	Pd	—	—	N	Segment output 7
79	VLOAD	VLOAD	—	—	—	—	—	—	N	FL driver pull-down resistor connection (–30V)
80	P87/FIP20	SEG8	O	—	Z	Pd	—	—	N	Segment output 8
81	P86/FIP19	SEG9	O	—	Z	Pd	—	—	N	Segment output 9
82	P85/FIP18	SEG10	O	—	Z	Pd	—	—	N	Segment output 10
83	P84/FIP17	SEG11	O	—	Z	Pd	—	—	N	Segment output 11
84	P83/FIP16	SEG12	O	—	Z	Pd	—	—	N	Segment output 12
85	P82/FIP15	SEG13	O	—	Z	Pd	—	—	N	Segment output 13
86	P81/FIP14	SEG14	O	—	Z	Pd	—	—	N	Segment output 14
87	P80/FIP13	SEG15	O	—	Z	Pd	—	—	N	Segment output 15
88	FIP12	SEG16	O	—	Z	Pd	—	—	N	Segment output 16
89	FIP11	DIG12	O	—	Z	Pd	—	—	—	Digit output 12
90	FIP10	DIG11	O	—	Z	Pd	—	—	—	Digit output 11
91	FIP9	DIG10	O	—	Z	Pd	—	—	—	Digit output 10
92	FIP8	DIG9	O	—	Z	Pd	—	—	—	Digit output 9
93	FIP7	DIG8	O	—	Z	Pd	—	—	—	Digit output 8
94	FIP6	DIG7	O	—	Z	Pd	—	—	—	Digit output 7
95	FIP5	DIG6	O	—	Z	Pd	—	—	—	Digit output 6
96	FIP4	DIG5	O	—	Z	Pd	—	—	—	Digit output 5
97	FIP3	DIG4	O	—	Z	Pd	—	—	—	Digit output 4
98	FIP2	DIG3	O	—	Z	Pd	—	—	—	Digit output 3
99	FIP1	DIG2	O	—	Z	Pd	—	—	—	Digit output 2
100	FIP0	DIG1	O	—	Z	Pd	—	—	—	Digit output 1

Det / Lv: Level detect, Ed: Edge detect, A: Analog volt detect

Res / Z: Hi-impedance at reset

Ext / Pd: Pull-down, Pu: Pull-up

Mo / Y: with mask option, N: without mask option

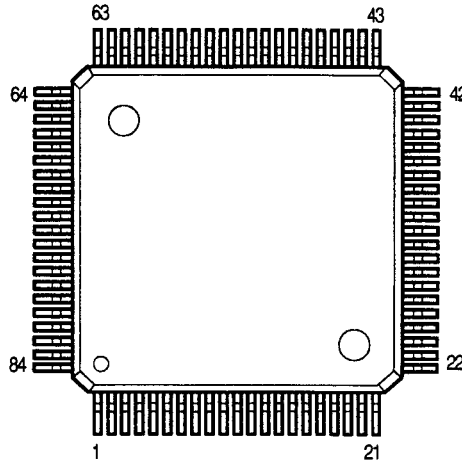
**MN1873223APB
(IC701)**

●MN1873223 Terminal Function

Pin No.	Symbol	Port	I/O	Log	INT	Typ	Function
1	KEY1	P21/ADIN1	I	A/D	Hi-z	—	Not used: Unit A/D key input
2	KEY0	P20/ADIN0	I	A/D	Hi-z	—	Not used: Unit A/D key input
3	VDD	VREFH	I	—	—	—	Ref. V for analog input (LOW)
4	+5V	VDD	—	—	—	—	μcom power voltage
5	8Mhz	OSC2	O	—	—	—	μcom system clock output
6	8Mhz	OSC1	I	—	—	—	μcom system clock input
7	GND	VSS	—	—	—	—	μcom GND
8	GND	XI	I	—	—	—	Not used: μcom sub-clock input
9	---	XO	O	—	—	—	Not used: μcom sub-clock output
10	GND	CM	I	—	—	C	μcom chip mode select input
11	HCK	P93/SBT2	O	—	Hi-z	—	VCD module clock output, CD: Ext. PU
12	HDIO	P92/SBI2	I	—	Hi-z	C	VCD module data input, CD: Ext. UP
13	HDIO	P91/SBO2	O	—	Hi-z	C	VCD module data output
14	HSEL	P90/BUZ	O	—	Hi-z	—	VCD module serial communication select output
15	GND	VPP	—	—	Hi-z	P	VPP: connect to GND
16	NC	P67/SEG15	O	—	Hi-z	P	Not used: Lo output at NC
17	NC	P66/SEG14	O	—	Hi-z	P	Not used: Lo output at NC
18	NC	P65/SEG13	O	—	Hi-z	P	Not used: Lo output at NC
19	NC	P64/SEG12	O	—	L	P	Not used: Lo output at NC
20	NC	P63/SEG11	O	—	L	P	Not used: Lo output at NC
21	NC	P62/SEG10	O	—	L	P	Not used: Lo output at NC
22	ENOUT	P61/SEG9	O	—	L	P	FL display data enable output
23	RQOUT	P60/SEG8	O	—	L	P	FL display request output
24	DATA7	P57/SEG7	O	—	L	P	FL display data output (bit 7)
25	DATA6	P56/SEG6	O	—	L	P	FL display data output (bit 6)
26	DATA5	P55/SEG5	O	—	L	P	FL display data output (bit 5)
27	DATA4	P54/SEG4	O	—	L	P	FL display data output (bit 4)
28	DATA3	P53/SEG3	O	—	L	P	FL display data output (bit 3)
29	DATA2	P52/SEG2	O	—	L	P	FL display data output (bit 2)
30	DATA1	P51/SEG1	O	—	L	P	FL display data output (bit 1)
31	DATA0	P50/SEG0	O	—	L	P	FL display data output (bit 0)
32	NC	P77/DGT0	O	—	L	P	Not used: Lo output at NC
33	POWER	P76/DGT1	O	—	L	P	WAKEUP output for CD, on request: Hi
34	LED3G	P75/DGT2	O	—	L	P	Disc 3 green LED output, light: Hi
35	LED3R	P74/DGT3	O	—	L	P	Disc 3 red LED output, light: Hi
36	LED2G	P73/DGT4	O	—	L	P	Disc 2 green LED output, light: Hi
37	LED2R	P72/DGT5	O	—	L	P	Disc 2 red LED output, light: Hi
38	LED1G	P71/DGT6	O	—	L	P	Disc 1 green LED output, light: Hi
39	LED1R	P70/DGT7	O	—	L	P	Disc 1 red LED output, light: Hi
40	TRAY-	P87/DGT8	O	—	Hi-z	P	Changer mecha. cam motor+ (X2M)/CD mecha. open (X2S)
41	TRAY+	P86/DGT9	O	—	Hi-z	P	Changer mecha. cam motor+ (X2M)/CD mecha. close (X2S)
42	CAM -	P85/DGT10	O	—	Hi-z	P	Changer mecha. cam motor- (X2M)/Not used NC (X2S)

Pin No.	Symbol	Port	I/O	Log	INT	Typ	Function
43	CAM+	P84/DGT11	O		Hi-z	P	Changer mecha. cam motor+ (X2M)/Not used NC (X2S)
44	CDPWR	P83/DGT12	O		Hi-z	P	CD power control output, power on: Hi
45	DRVMT	P82/DGT13	O		Hi-z	P	Driver mute output, mute: Lo
46	DMUTE	P81/DGT14	O		Hi-z	P	CD-DSP DMUTE, mute: Hi/Not used NC (X2S)
47	AMUTE	P80/DGT15	O		Hi-z	P	Audio mute output, mute: Hi
48	---	SYNC	O	---	Hi-z	C	Not used: NC
49	TLOCK	P17/PWM2	I	---	Hi-z		CD-DSP TLOCK input (X2M)/Not used ext. DW (X2S)
50	FLOCK	P16/PWM1	I	---	Hi-z		CD-DSP FLOCK input (X2M)/Not used ext. SW (X2S)
51	SENSE	P15/RMOUT	I	---	Hi-z		CD-DSP SENSE input (X2M)/Not used ext. DW (X2S)
52	MCLK	P14/TCO35	O	---	Hi-z	C	CD-DSP serial communication clock output
53	STAT	P13/TCIO4	I	---	Hi-z		CD-DSP serial communication status input
54	MDATA	P12/TCI3	O	---	Hi-z	C	CD-DSP serial communication data output
55	MLD	P11/TCO1	O	---	Hi-z	C	CD-DSP serial communication load output
56	SRST	P10/TCIO0	O		Hi-z	C	CD-DSP reset output, reset: Hi
57	RESET	P07/RST	I		Hi-z		µcom reset input, reset: Lo
58	VRST	P06/PSBT0	O		Hi-z	C	VCD module reset output, reset: Hi
59	SQCK	P05/SBT1	O	---	Hi-z	C	Sub Q code clock output
60	SUBQ	P04/SBI1	I	---	Hi-z		Sub Q code data input
61	NTSC/PAL	P03/SBO1	I	---	Hi-z		NTSC/PAL switching input, NTSC: Lo
62	BUSCLK	P02/SBT0	I	---	Hi-z		DENON BUS communication clock input
63	BUSI	P01/SBI0	I	---	Hi-z		DENON BUS communication data input
64	BUSO	P00/SBO0	O	---	Hi-z	C	DENON BUS communication data output
65	TRYSW4	P47	I	---	Hi-z		Changer mecha. tray SW4 (X2M)/Not used ext. DW (X2S)
66	TRYSW3	P46	I	---	Hi-z		Changer mecha. tray SW3 (X2M)/Not used ext. DW (X2S)
67	TRYSW2	P45	I	---	Hi-z		Changer mecha. tray SW2 (X2M)/CD mecha. close SW (X2S)
68	TRYSW1	P44	I	---	Hi-z		Changer mecha. tray SW1 (X2M)/CD mecha. open SW (X2S)
69	CANSW4	P43	I	---	Hi-z		Changer mecha. cam SW4 (X2M)/Not used ext. DW (X2S)
70	CAMSW3	P42	I	---	Hi-z		Changer mecha. cam SW3 (X2M)/Not used ext. DW (X2S)
71	CAMSW2	P41	I	---	Hi-z		Changer mecha. cam SW2 (X2M)/Not used ext. DW (X2S)
72	CAMSW1	P40	I	---	Hi-z		Changer mecha. cam SW1 (X2M)/Not used ext. DW (X2S)
73	HRDY	P34/PWM0	I	---	Hi-z		VCD module ready input, CD: Ext. up
74	PWRSW	P33/IRQ3	I		Hi-z		Power on SW input, SW push: Lo
75	HINT	P32/IRQ2	I	---	Hi-z		VCD module interrupt input, CD: Ext. up
76	CE	P31/IRQ1	I	---	Hi-z		FL display CE interrupt input
77	BUSINT	P30/IRQ0	I	---	Hi-z		DENON BUS communication interrupt input
78	GND	VREFL	I	---	Hi-z		Ref. V for analog input (LOW)
79	CD/VCD	P27/ADIN7	I	---	Hi-z		CD/VCD switching input, CD: Lo
80	LMTSW	P26/ADIN6	I		Hi-z		Pickup inner-most detect input, inner-most: Lo at on
81	F.CD	P25/ADIN5	I		Hi-z		CD function input, CD: Hi
82	KEY4	P24/ADIN4	I	A/D	Hi-z		Not used: Unit A/D key input
83	KEY3	P23/ADIN3	I	A/D	Hi-z		Not used: Unit A/D key input
84	KEY2	P22/ADIN2	I	A/D	Hi-z		Not used: Unit A/D key input

SEMICONDUCTORS

● IC's

LC72131M (IC101)

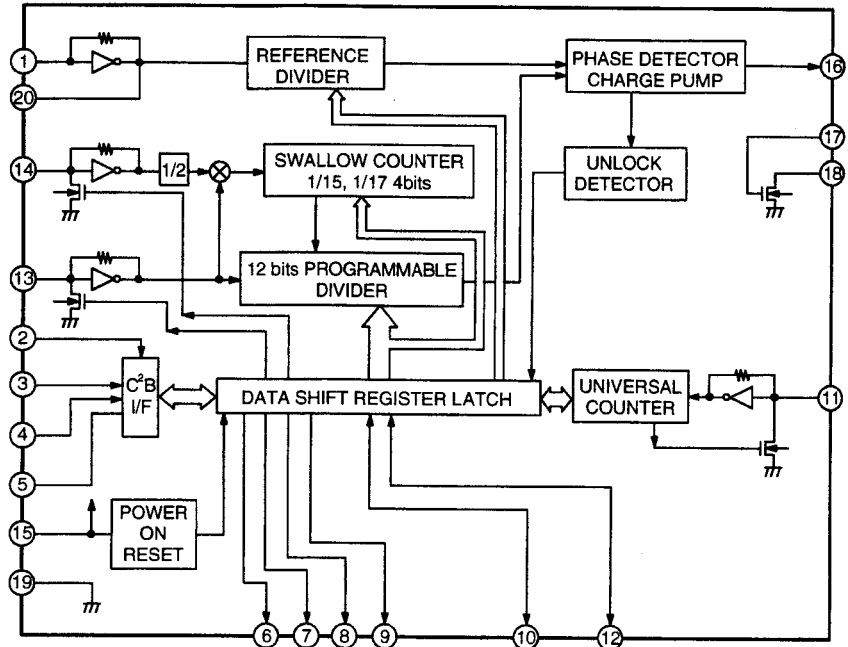
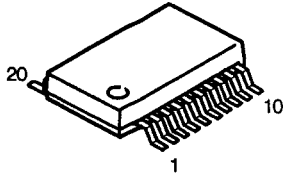

LA1837 (IC201)

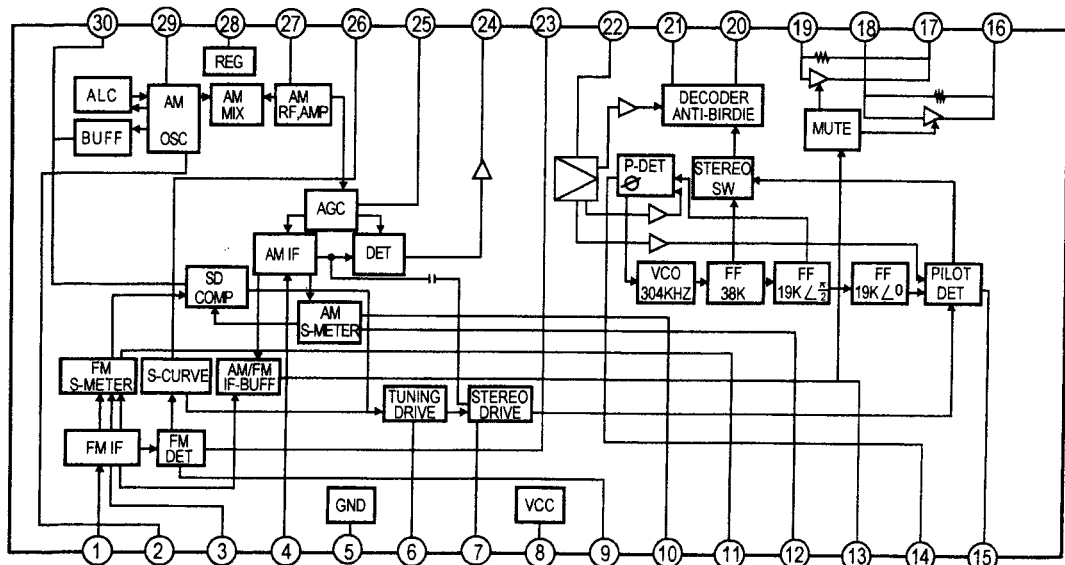
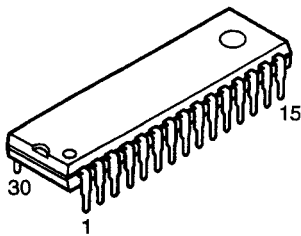

LC7535M (IC401)

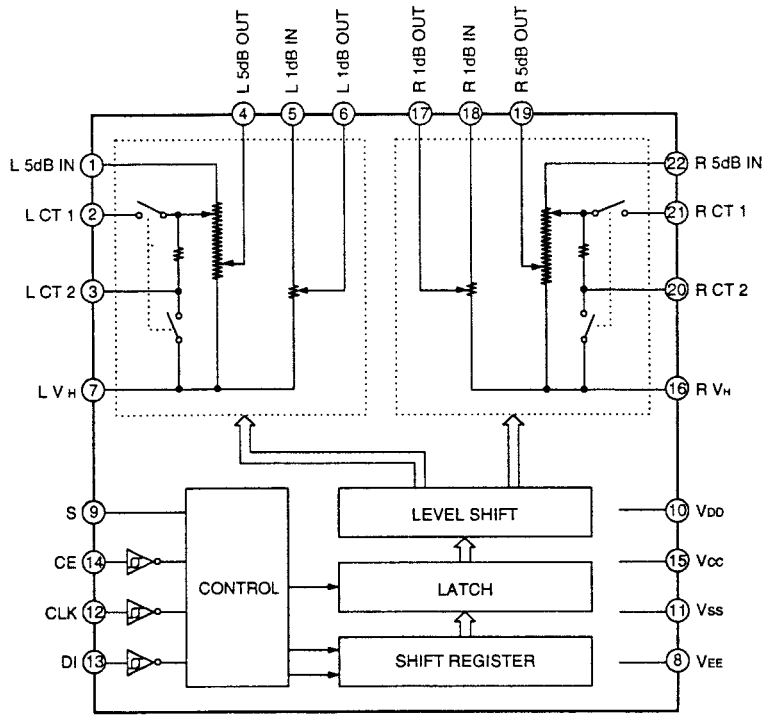
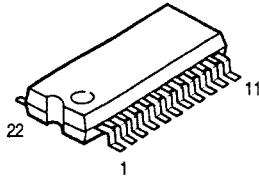

LC72720M (IC251)

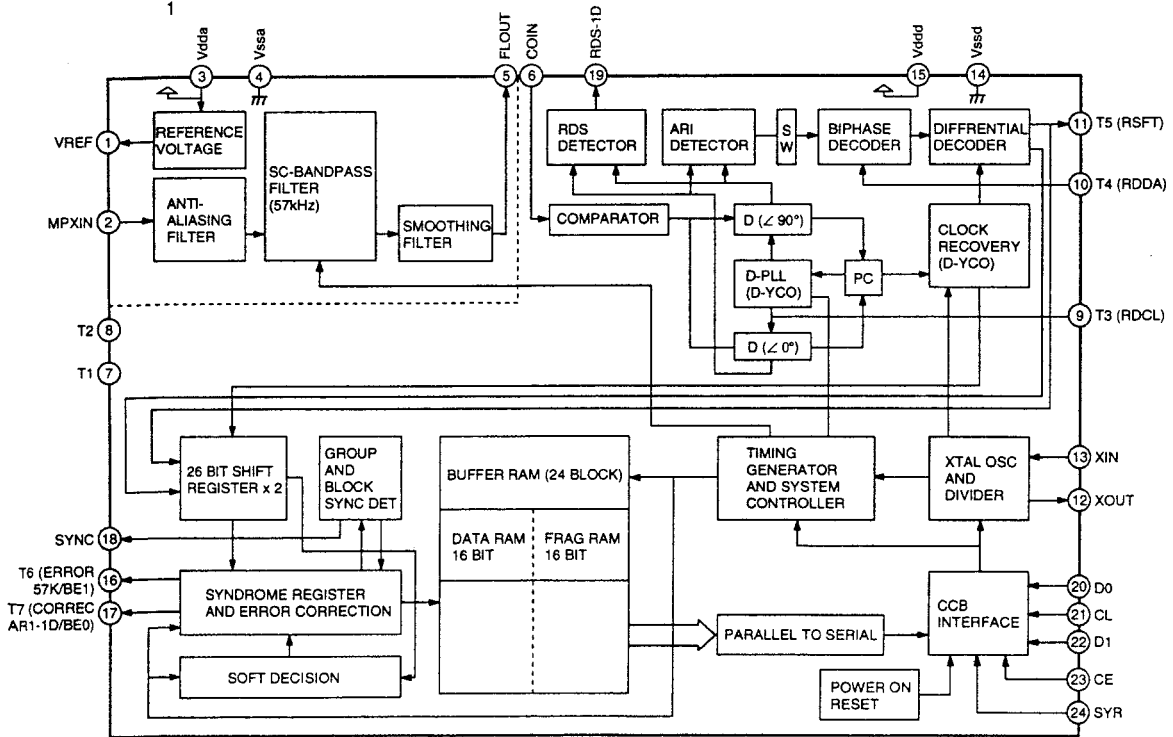
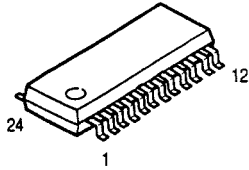

LC78211 (IC302)

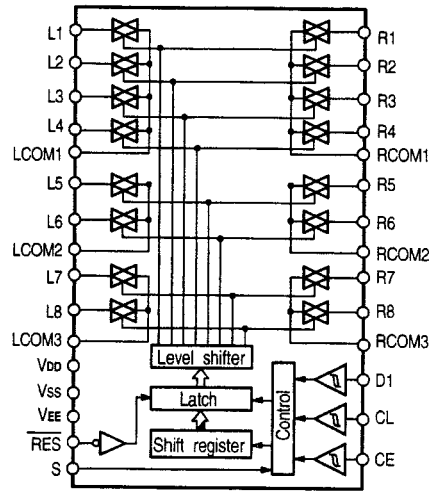
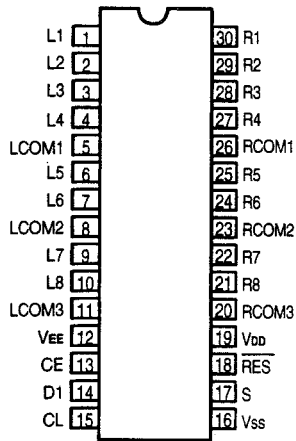

STK405-050A (IC501)

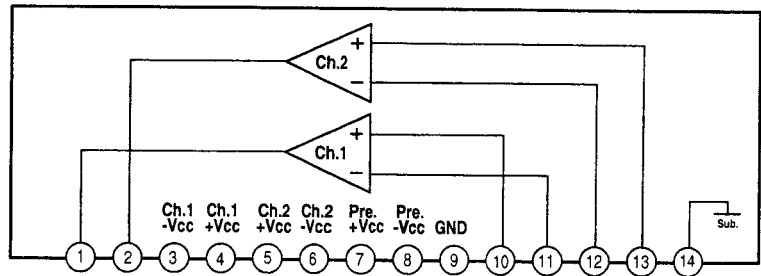
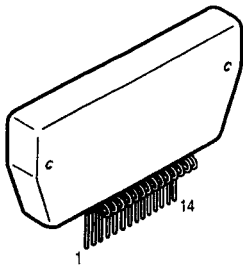

M62412P (IC405)

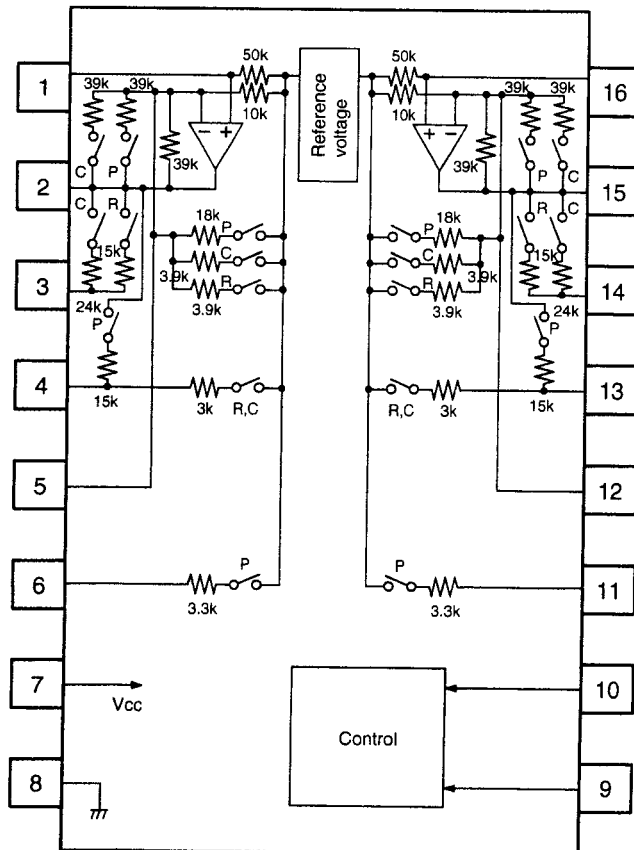
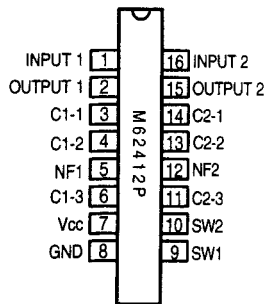

BR9040F (IC602)

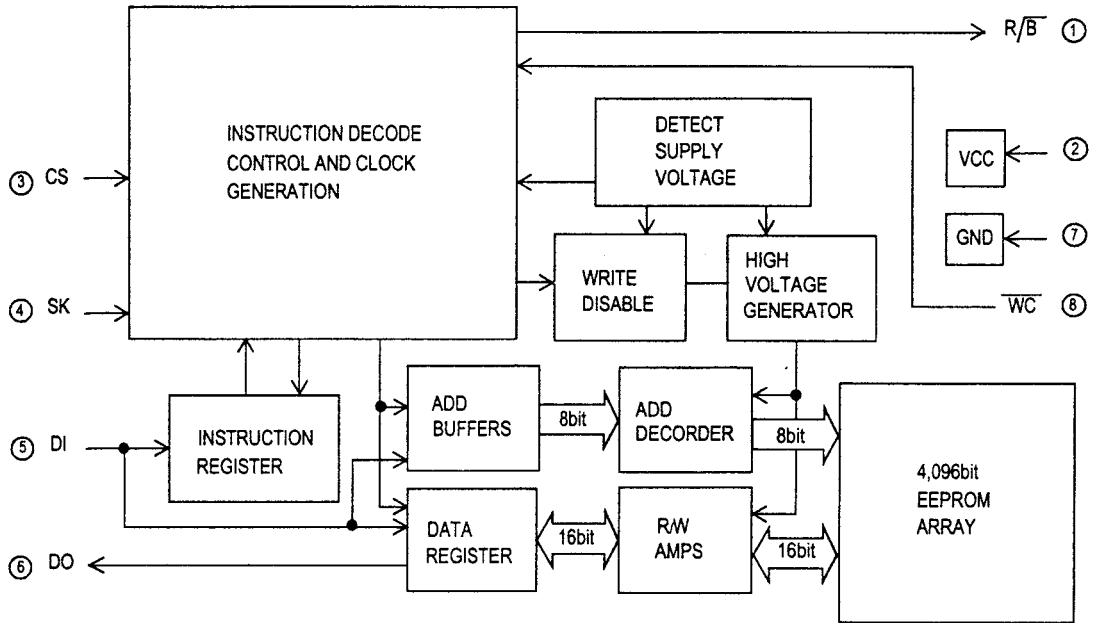
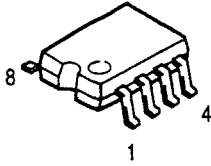

BA4558F (IC301, 402, 403, 404)
BA15218F (IC702)

KIA7045P (IC603)

KIA7806PI (IC001)
KIA7808PI (IC003)
KIA7809PI (IC202)

PQ12RAI (IC002)

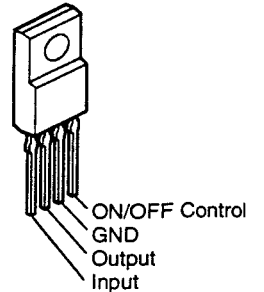
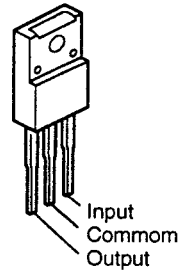
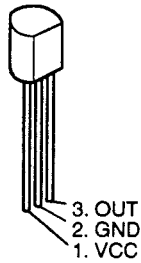
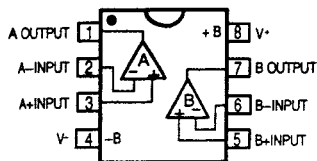
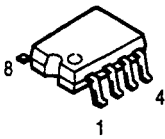

● TRANSISTORS

KTC3202

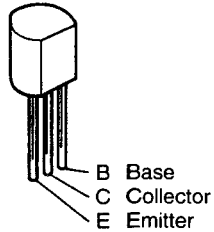

2SB647 (C)
HIT5610C

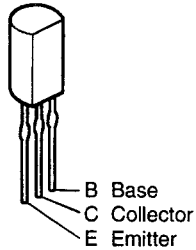

KTA1267

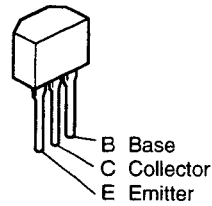

2SC2058S(Q)

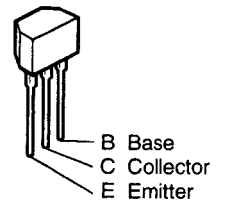

2SK161

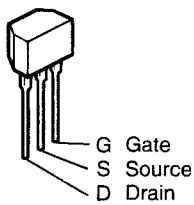

2SA1037K (S)
2SC2412K (S)

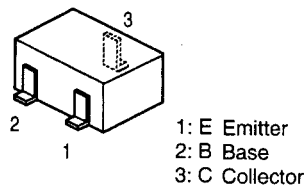

DTA114EK
DTC114EK
DTA144EK
DTC144EK
DTC323TK

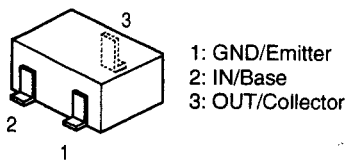

PNP Type

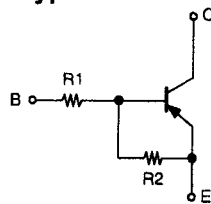

	R1	R1
DTA114EK	10 kohm	10 kohm
DTA144EK	47 kohm	47 kohm

NPN Type

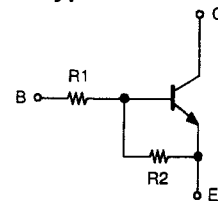

	R1	R1
DTC144EK	47 kohm	47 kohm
DTC323TK	2.2 kohm	—
DTC114EK	10 kohm	10 kohm

● DIODES (including LED)

1N4531

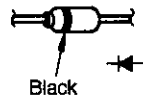

Black

1SS133

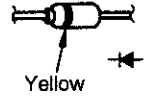

Yellow

1N4002

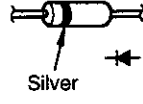

Silver

HZ5B-2
MTZ-J12C
MTZ-J27A
MTZ-J5.1C
MTZ-J6.2A

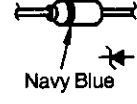

Navy Blue

1SS355

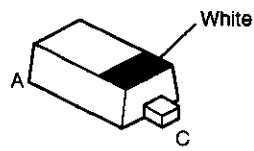

White

D3SBA60

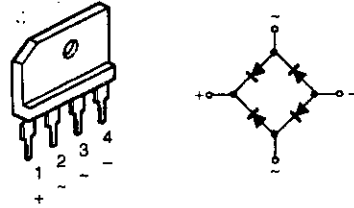

LH5230/P1 (Red)

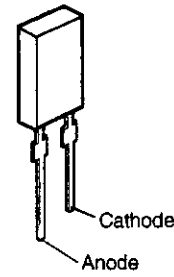

● IR SENSOR

RPM6938-SV4

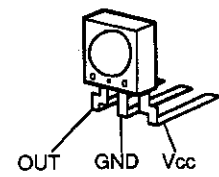

● OPTICAL OUTPUT

GP1F32T (JK701)

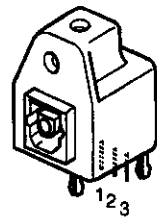

1 Vin
2 Vcc
3 GND

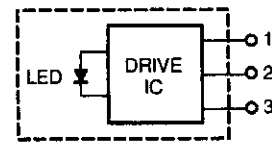

LED : Ga Al As
DRIVE IC : Silicon

● FL DISPLAY 12BT110GK (FL681)

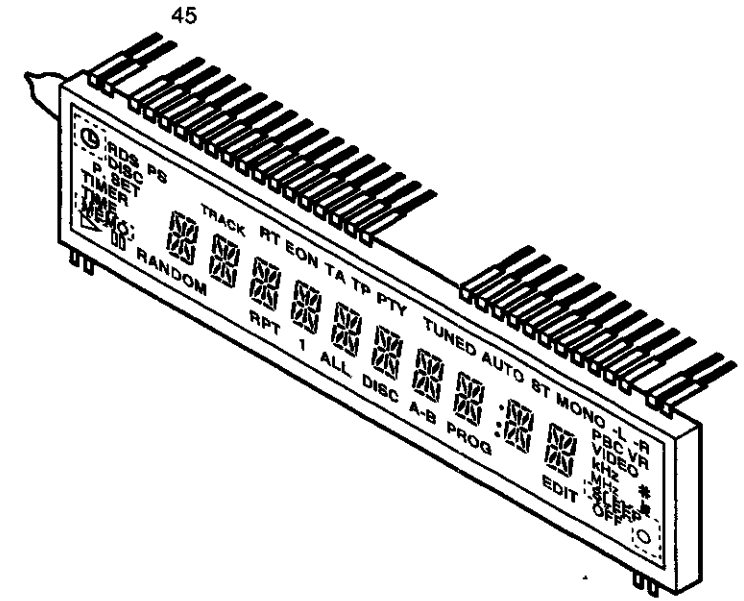

Pin Connection

Pin No.	1	2	3	4	5	6	7	8	9	10	11	12	13	14	15	16	17	18	19	20	21	22	23	24
Connection	F1	F1	NP	NP	P1	P2	P3	P4	P5	P6	P7	P8	P9	P10	P11	P12	P13	P14	P15	P16	NX	NX	NX	NX

Pin No.	25	26	27	28	29	30	31	32	33	34	35	36	37	38	39	40	41	42	43	44	45
Connection	NX	NX	NX	NX	NX	12G	11G	10G	9G	8G	7G	6G	5G	4G	3G	2G	1G	NP	NP	F2	F2

- NOTE
- 1) F1, F2 Filament
 - 2) NP No pin
 - 3) NX No ext. pin
 - 4) DL Datum line
 - 5) 1G-12G Grid
 - 6) Visual field: upper 39°, lower 17° min.

NOTE FOR PARTS LIST

- 1 Part indicated with the mark "⊙" are not always in stock and possibly to take a long period of time for supplying, or in some case supplying of part may be refused.
- 1 When ordering of part, clearly indicate "1" and "I" (i) to avoid mis-supplying.
- 1 Ordering part without stating its part number can not be supplied.
- 1 Part indicated with the mark "H" is not illustrated in the exploded view.
- 1 Not including Carbon Film ±5%, 1/4W Type in the P.W.Board parts list. (Refer to the Schematic Diagram for those parts.)

WARNING:

Parts marked with this symbol have critical characteristics. Use ONLY replacement parts recommended by the manufacturer.

1 Resistors

Ex.: RN 14K 2E 182 G ER
 Type Shape Power Resist- Allowable Others
 and per- ance error

RD : Carbon	2B : 1/8W	F : ±1%	P : Pulse-resistant type
RC : Composition	2E : 1/4W	G : ±2%	NL : Low noise type
RS : Metal oxide film	2H : 1/2W	J : ±5%	NB : Non-burning type
RW : Winding	3A : 1W	K : ±10%	FR : Fuse-resistor
RN : Metal film	3D : 2W	M : ±20%	F : Lead wire forming
RK : Metal mixture	3F : 3W		
	3H : 5W		

Resistance

$\frac{1}{\text{---}} \frac{R}{\text{---}} \frac{2}{\text{---}}$ ⇒ 1800 ohm = 1.8 kohm
 Indicates number of zeros after effective number.
 2-digit effective number.

• Units: ohm

$\frac{1}{\text{---}} \frac{R}{\text{---}} \frac{2}{\text{---}}$ ⇒ 1.2 ohm
 1-digit effective number.
 2-digit effective number, decimal point indicated by R.

• Units: ohm

1 Capacitors

Ex.: CE 04W 1H 2R2 M BP
 Type Shape Dielectric Capacity Allowable Others
 and per- strength error

CE : Aluminum foil electrolytic	0J : 6.3V	F : ±1%	HS : High stability type
CA : Aluminum solid electrolytic	1A : 10V	G : ±2%	BP : Non-polar type
CS : Tantalum electrolytic	1C : 16V	J : ±5%	HR : Ripple-resistant type
CQ : Film	1E : 25V	K : ±10%	DL : For charge and discharge
CK : Ceramic	1V : 35V	M : ±20%	HF : For assuring high frequency
CC : Ceramic	1H : 50V	Z : +80%	U : UL part
CP : Oil	2A : 100V	-20%	C : CSA part
CM : Mica	2B : 125V	P : +100%	W : UL-CSA type
CF : Metalized	2C : 160V	-0%	F : Lead wire forming
CH : Metalized	2D : 200V	C : ±0.25pF	
	2E : 250V	D : ±0.5pF	
	2H : 500V	= : Others	
	2J : 630V		

Capacity (electrolyte only)

$\frac{2}{\text{---}} \frac{2}{\text{---}} \frac{2}{\text{---}}$ ⇒ 2200μF
 Indicates number of zeros after effective number.
 2-digit effective number.

• Units: μF.

$\frac{2}{\text{---}} \frac{R}{\text{---}} \frac{2}{\text{---}}$ ⇒ 2.2μF
 1-digit effective number.
 2-digit effective number, decimal point indicated by R.

• Units: μF.

Capacity (except electrolyte)

$\frac{2}{\text{---}} \frac{2}{\text{---}} \frac{2}{\text{---}}$ ⇒ 2200pF=0.0022μF
 (More than 2) — Indicates number of zeros after effective number.
 2-digit effective number.

• Units: pF.

$\frac{2}{\text{---}} \frac{2}{\text{---}} \frac{1}{\text{---}}$ ⇒ 220pF
 (0 or 1) — Indicates number of zeros after effective number.
 2-digit effective number.

• Units: pF.

• When the dielectric strength is indicated in AC, "AC" is included after the dielectric strength value.

PARTS LIST OF P.W.B. UNIT MAIN P.W.B. UNIT ASS'Y

Ref. No.	Part No.	Part Name	Remarks	Ref. No.	Part No.	Part Name	Remarks
SEMICONDUCTORS GROUP				RESISTORS GROUP			
ZD001	9L2 3482 71M	Zener diode MTZJ27A		R001		Composition 2.7Mohm 1/2W	RC14GF2H275KBFO U.S.A./Canada models
ZD002	9L2 3317 95M	Zener diode HZ5B-2		R002-005		Carbon chip 10kohm 1/16W	RMC73M-1F103JR
ZD003	9L2 3481 93M	Zener diode MTZJ12C		R006		Carbon film 3.3kohm 1/2W	RD14S2H332JB
ZD401	9L2 3481 03M	Zener diode MTZJ5.1C		R007,008		Carbon chip 100ohm 1/16W	RMC73M-1J101JR
ZD601,602	9L2 3481 21M	Zener diode MTZJ6.2A		R011		Carbon film 2.2kohm 1/2W	RD14S2H222JB
IC301	9L2 3883 01R	IC BA4558F		R012		Carbon film 1kohm 1/4W	RD14S2E102JB
IC302	9L2 3016 92W	IC LC78211		R013		Carbon chip 6.8kohm 1/16W	RMC73M-1J682JR
IC401	9LC K098 51R	IC LC7535M		R014		Carbon film 22kohm 1/6W	RD14S1J223JB
IC402-404	9L2 3883 01R	IC BA4558F		R015		Carbon chip 22kohm 1/16W	RMC73M-1J223JR
IC405	9LC P025 71	IC M62412P		R018		Carbon film 1kohm 1/6W	RD14S1J102JB
IC501	9LC P045 22	IC STK405-050A		R301,302		Carbon chip 470ohm 1/16W	RMC73M-1F471JR
IC601	9LC K309 63	IC UPD780208GF-026-3BA	Except U.S.A./ Canada model	R303,304		Carbon chip 1Mohm 1/16W	RMC73M-1F105JR
IC601	9LC K309 64	IC UPD780208GF-028-3BA	U.S.A./Canada models	R305,306		Carbon chip 470ohm 1/16W	RMC73M-1F471JR
IC602	9LC K076 11R	IC BR9040F		R307,308		Carbon chip 1Mohm 1/16W	RMC73M-1F105JR
IC603	9LC P007 12R	IC KIA7045P		R309,310		Carbon chip 100ohm 1/16W	RMC73M-1F101JR
PR001,002	9LF N001 82M	Protector 250mA		R311,312		Carbon chip 100kohm 1/16W	RMC73M-1J104JR
PR003,004	9LA Z001 01M	Protector 500mA		R313,314		Carbon chip 100ohm 1/16W	RMC73M-1F101JR
Q001	9LC A006 61R	Transistor KTA1267(GR)		R315,316		Carbon chip 100kohm 1/16W	RMC73M-1J104JR
Q002	9L2 3256 91R	Transistor 2SC2412K		R317,318		Carbon chip 100ohm 1/16W	RMC73M-1F101JR
Q003	9L2 3286 25T	Transistor 2SB647C		R319-321		Carbon chip 100kohm 1/16W	RMC73M-1J104JR
Q004	9LC A006 61R	Transistor KTA1267(GR)		R322-325		Carbon chip 0ohm 1/16W	RMC73M-1J000JR
Q401,402	9LC F009 91R	Transistor KTC3202(Y)		R326,327		Carbon chip 470kohm 1/16W	RMC73M-1F474JR
Q501	9L2 3256 91R	Transistor 2SC2412K		R328,329		Carbon chip 100kohm 1/16W	RMC73M-1F104JR
Q502	9LC A006 91R	Transistor 2SA1037AK		R330,331		Carbon chip 100ohm 1/16W	RMC73M-1F101JR
Q503	9L2 3256 91R	Transistor 2SC2412K		R332,333		Carbon chip 100kohm 1/16W	RMC73M-1F104JR
Q504,505	9LC A005 81R	Transistor DTC323TK		R334,335		Carbon chip 0ohm 1/16W	RMC73M-1J000JR
Q601	9L2 3166 91R	Transistor DTC144EK		R336,337		Carbon chip 100kohm 1/16W	RMC73M-1F104JR
Q602	9LC A002 92R	Transistor DTA144EK		R338		Carbon chip 680kohm 1/16W	RMC73M1F684JR
Q603	9LC A006 91R	Transistor 2SA1037AK		R350,351		Carbon chip 1kohm 1/16W	RMC73M1F102JR
Q604,605	9L2 3256 91R	Transistor 2SC2412K		R401,402		Carbon chip 330ohm 1/16W	RMC73M-1F331JR
Q606	9L2 3163 61R	Transistor DTC114EK		R403,404		Carbon chip 470kohm 1/16W	RMC73M-1F474JR
D001-006	9L2 3980 61T	Diode 1N4002		R405-410		Carbon chip 1Mohm 1/16W	RMC73M-1F105JR
D007	9L2 3989 21T	Diode 1SS133/1N4531		R411,412		Carbon chip 560ohm 1/16W	RMC73M-1F561JR
D008	9L2 3420 63	Diode D3SBA60		R413,414		Carbon chip 1kohm 1/16W	RMC73M-1F102JR
D009	9L2 3980 61T	Diode 1N4002		R415,416		Carbon chip 1Mohm 1/16W	RMC73M-1F105JR
D301,302	9LC C000 03R	Diode 1SS355		R417,418		Carbon chip 10kohm 1/16W	RMC73M-1F103JR
D401-404	9L2 3989 21T	Diode 1N4531		R425,426		Carbon chip 100kohm 1/16W	RMC73M-1J104JR
D501	9L2 3989 21T	Diode 1N4531		R427,428		Carbon chip 2.2kohm 1/16W	RMC73M-1F222JR
D503	9L2 3989 21T	Diode 1N4531					
D504	9LC H019 71	LED LH5230/PI					
D601-604	9L2 3989 21T	Diode 1N4531					
D605	9L2 3980 61T	Diode 1N4002					

Ref. No.	Part No.	Part Name	Remarks	Ref. No.	Part No.	Part Name	Remarks
R429,430		Carbon chip 0ohm 1/16W	RMC73M-1F000JR	C010,011		Electrolytic 10μF/50V	CE04W1H100MB(SSL)
R431,432		Carbon chip 1kohm 1/16W	RMC73M-1F102JR	C012		Electrolytic 100μF/50V	CE04W1H101MB(SSL)
R440-443		Carbon film 1.2kohm 1/6W	RD14S1J122JB	C013		Electrolytic 10μF/50V	CE04W1H100MB(SSL)
R445,446		Carbon chip 33kohm 1/16W	RMC73M1J333JR	C014,015		Ceramic chip 0.01μF/50V	CK73MF1H103ZR
				C017		Electrolytic 10μF/50V	CE04W1H100MB(SSL)
R501,502		Carbon chip 2.7kohm 1/16W	RMC73M-1J272JR	C018	9LA L010 01	Electrolytic 4700μF/35V	CE68W1V472(SMH)
R503,504	9LA T011 71T	Metal film 100ohm 1/4W (FR)	RN45S2E101JB-FR	C019		Ceramic chip 0.01μF/50V	CK73MF1H103ZR
R505,506		Carbon chip 56kohm 1/16W	RMC73M-1J563JR	C021		Electrolytic 10μF/50V	CE04W1H100MB(SSL)
R507,508	9LA T012 17T	Carbon film 10ohm 1/4W (NB)	RD14S2E100JB-NB	C022		Electrolytic 100μF/10V	CE04W1A101MB(SSL)
R509-511		Carbon chip 22kohm 1/16W	RMC73M-1J223JR	C023		Ceramic chip 0.01μF/50V	CK73MF1H103ZR
R512		Carbon chip 10kohm 1/16W	RMC73M-1F103JR	C027		Mylar film 0.1μF/50V	CQ92M1H104KB(AMZ)
R514,515	9LA T010 47R	Non-burning type 4.7ohm 1W	RE4R7J000INT				
R517,518	9LA T010 96R	Non-burning type 330ohm 1W	RE331J000INT	C301,302		Ceramic chip 1000pF/50V	CK73MSL1H102JR
R519	9LA T011 78T	Metal film 82ohm 1/4W (FR)	RN45S2E820JB-FR	C303		Ceramic chip 0.01μF/50V	CK73MF1H103ZR
R520		Carbon chip 10kohm 1/16W	RMC73M-1F103JR	C304,305		Ceramic chip 470pF/50V	CK73MSL1H471JR
R521		Carbon chip 2.7kohm 1/16W	RMC73M-1F272JR	C306,307		Ceramic chip 1000pF/50V	CK73MSL1H102JR
R522,523		Carbon chip 22kohm 1/16W	RMC73M-1J223JR	C308		Ceramic chip 0.01μF/50V	CK73MF1H103ZR
R525,526		Carbon chip 56kohm 1/16W	RMC73M-1J563JR	C309,310		Ceramic chip 470pF/50V	CK73MSL1H471JR
R537,538		Carbon chip 56kohm 1/16W	EMC73M1J563JR	C311,312		Ceramic chip 220pF/50V	CK73MSL1H221JR
				C313		Ceramic chip 0.01μF/50V	CK73MF1H103ZR
R601		Carbon chip 470ohm 1/16W	RMC73M-1J471JR	C314-319		Ceramic chip 100pF/50V	CK73MSL1H101JR
R602-605		Carbon chip 10kohm 1/16W	RMC73M-1F103JR	C320,321		Electrolytic 10μF/25V	CE04W1E100M(SRA)
R606,607		Carbon chip 1kohm 1/16W	RMC73M-1J102JR	C322		Electrolytic 1μF/50V	CE04W1H010M(SRA)
R608-610		Carbon chip 10kohm 1/16W	RMC73M-1F103JR	C323		Electrolytic 1μF/50V	CE04W1H010M(SRA)
R612-619		Carbon chip 47kohm 1/16W	RMC73M-1J473JR	C324-327		Electrolytic 10μF/25V	CE04W1E100M(SRA)
R620,621		Carbon chip 10kohm 1/16W	RMC73M-1F103JR	C328		Ceramic chip 0.022μF/50V	CK73MF223ZR
R622,623		Carbon chip 22kohm 1/16W	RMC73M-1J223JR	C331		Electrolytic 47μF/25V	CE04W1E470MB(SSL)
R624		Carbon chip 10kohm 1/16W	RMC73M-1F103JR	C332		Electrolytic 10μF/50V	CE04W1H100MB
R625,626		Carbon chip 22kohm 1/16W	RMC73M-1J223JR				
R627		Carbon chip 2.2kohm 1/16W	RMC73M-1F222JR	C403,404		Electrolytic 47μF/25V	CE04W1E470MB(SSL)
R628		Carbon chip 22kohm 1/16W	RMC73M-1J223JR	C405,406		Electrolytic 0.15μF/50V	CE04W1HR15MB
R629		Carbon chip 1kohm 1/16W	RMC73M-1F102JR	C407,408		Electrolytic 0.22μF/50V	CE04W1HR22MB
R630		Carbon chip 47kohm 1/16W	RMC73M-1J473JR	C409,410		Electrolytic 1μF/50V	CE04W1H010MB(SSL)
R631		Carbon chip 100ohm 1/16W	RMC73M-1J101JR	C411,412		Electrolytic 10μF/50V	CE04W1H100MB(SSL)
R632		Carbon chip 220ohm 1/16W	RMC73M-1J221JR	C413,414		Electrolytic 1μF/50V	CE04W1H010MB(SSL)
R633		Carbon chip 22kohm 1/16W	RMC73M-1F223JR	C415,416		Electrolytic 10μF/50V	CE04W1H100MB(SSL)
R634,635		Carbon chip 10kohm 1/16W	RMC73M-1F103JR	C417,418		Electrolytic 10μF/25V	CE04W1E100MB
R636,637		Carbon chip 0ohm 1/16W	RMC73M-1J000JR	C419,420		Ceramic chip 0.022μF/50V	CK73SB1H223KT
R638		Carbon chip 470ohm 1/16W	RMC73M-1J471JR	C421,422		Ceramic chip 4700pF/50V	CK73SB1H472KT
R639		Carbon chip 47kohm 1/16W	RMC73M-1F473JR	C423,424		Ceramic chip 0.1μF/25V	CK73SF1E104ZT
R640		Carbon chip 0ohm 1/16W	RMC73M-1J000JR	C425		Electrolytic 10μF/50V	CE04W1H100MB(SSL)
R641,642		Carbon chip 4.7kohm 1/16W	RMC73M-1F472JR	C426,427		Ceramic chip 1000pF/50V	CK73MB1H102KR
R643		Carbon chip 1kohm 1/16W	RMC73M-1F102JR	C428,429		Electrolytic 10μF/50V	CE04W1H100MB(SSL)
				C440		Electrolytic 1μF/50V	CE04W1H010MB(SSL)
				C501,502		Electrolytic 22μF/50V	CE04W1H220MB(SSL)
				C503,504		Electrolytic 100μF/50V	CE04W1H101MB(SSL)
				C505,506		Ceramic chip 10 pF/50V	CK73MSL100JR
				C507,508		Electrolytic 10μF/50V	CE04W1H100MB(SSL)
				C509		Electrolytic 330μF/6.3V	CE04W0J331MB
				C510,511		Mylar film 0.1μF/50V	CQ92M1H104KB(AMZ)
				C512,513		Ceramic chip 1000pF/50V	CC73MSL1H102JR
CAPACITORS GROUP							
C001,002		Ceramic chip 0.01μF/50V	CK73MF1H103ZR				
C003		Ceramic chip 0.047μF/50V	CK73MF1H473ZR				
C004		Electrolytic 100μF/50V	CE04W1H101MB(SSL)				
C005		Electrolytic 10μF/50V	CE04W1H100MB(SSL)				
C006		Ceramic chip 0.01μF/50V	CK73MF1H103ZR				
C008,009	9LA L010 01	Electrolytic 4700μF/35V	CE68W1V472(SMH)				

Ref. No.	Part No.	Part Name	Remarks	Ref. No.	Part No.	Part Name	Remarks	Q'ty
C514		Ceramic chip 0.1 μ F/25V	CK73MF1E104R	CN301B	9LE Y000 78	10P pin header(9110)		1
C515,516		Mylar film 0.01 μ F/50V	CQ92M1H103KB(AMZ)	CN302A	9LE Y000 95	7P socket(9110)		1
C517-519		Ceramic chip 0.01 μ F/50V	CK73M1H103ZR	CN302B	9LE Y000 75	7P pin header(9110)		1
C521,522		Electrolytic 4.7 μ F/50V	CE04W1H4R7MB(SSL)	CN303	9LE F069 47	10P KR-DA connector cord	L=200mm	1
C531-534		Ceramic chip 470pF/50V	CC73MSL1H471JR	CN501	9LE F069 29	9P KR-DA connector cord	L=240mm	1
C601		Electrolytic 22 μ F/50V	CE04W1H220MB(SSL)	CN502	9LE F042 53	5P PH connector cord	L=360mm	1
C602		Ceramic chip 0.01 μ F/50V	CK73MF1H103ZR	CN503	9LE F077 38	5P SAN-SAN connector cord	L=510mm	1
C603		Ceramic chip 0.1 μ F/50V	CK73MF1E104ZR	CN504	9L2 9091 77L	6P PH connector cord	L=430mm	1
C605,606		Ceramic chip 1000pF/50V	CK73MB1H102KR	CN601B	9LE D022 61	30P FFC connector (L)	<i>Base</i>	1
C631		Ceramic 0.1 μ F/16V	CK141C104ZB	CN603	9LE F068 32	4P KR-DA connector cord	L=300mm	1
			Except U.S.A./Canada model	CN703B	9LE Y000 82	13P pin header(9110)		1
				CN704B	9LE Y000 82	13P pin header(9110)		1
OTHER PARTS GROUP								
				WC001-003	—	Style pin		3
				WC005	—	Style pin		1
				WC008-010	—	Style pin		3
JK301	9LE R002 24	4P US pin jack		W501	9LE K002 83	1P board in wire (BLK)	L=100mm	1
JK302	9LE R002 23	6P US pin jack		W502	9LE K002 89	1P board in wire (YEL)	L=80mm	1
JK501	9L2 6950 33	Headphone jack		W503	9LE K002 88	1P board in wire (RED)	L=80mm	1
JK502	9LE R002 41	1P US pin jack		W505	—	UL wire (BLK)	UL 1007 #24S	1
JK503	9LE U000 86	4P SP terminal						
JK601,602	9L2 6714 13	Mini jack (3.5)		9LJ T082 31	Main P.W.B. Ass'y	U.S.A./Canada models		1
L501,502	9L2 2273 61	Audio trap coil		9LJ T082 32	Main P.W.B. Ass'y	Europe model only		1
E001,002	9L2 7292 52R	Fuse holder		9LJ T082 33	Main P.W.B. Ass'y	U.K. model only		1
E505	—	Lug terminal		9LJ T082 36	Main P.W.B. Ass'y	Asia model only		1
X601	9L2 1684 81	Crystal CST4.19MGW						
RY501	9LF J001 21	Relay						
PG001	9L2 6742 84	2P-4S VH plug						
PG002	9L2 6688 12W	3P VH pin post						
PG003	9L2 6752 82	3P PH pin post						
PG303	9L2 6752 89	10P PH pin post(L)						
PG501	9L2 9590 58	9P PH pin post						
PG502	9L2 9590 54	5P PH pin post						
PG504	9L2 9590 55	6P PH pin post						
PG602	9L2 6752 88	9P PH pin post(L)						
PG603	9L2 9590 53	4P PH pin post						
PG705	9L2 9590 56	7P PH pin post						
CN002	9LE F059 13	3P VH connector cord	L=180mm					
CN003	9LE F068 16	3P KR-DA connector cord	L=430mm					
CN004	9L2 9097 02	10P SAN-SAN connector cord	L=80mm					
CN101B	9LE Y001 02	13P socket(9110)						
CN301A	9LE Y000 98	10P socket(9110)						

TUNER/CD/DISPLAY P.W.B. UNIT ASS'Y

Ref. No.	Part No.	Part Name	Remarks	Ref. No.	Part No.	Part Name	Remarks
SEMICONDUCTORS GROUP							
IC101	9LC K098 31R	IC LC72131M		R116		Carbon chip 1.8kohm 1/16W	RMC73M-1F182JR
IC201	9LC P045 01	IC LA1837		R117		Carbon chip 1kohm 1/16W	RMC73M-1F102JR
IC202	9LC P024 14	IC KIA7809PI		R151		Carbon chip 3.3kohm 1/16W	RMC73M-1F332JR
IC251	9LC K098 41R	IC LC72720NM	Except Asia model	R152		Carbon chip 100kohm 1/16W	RMC73M-1F104JR
IC701	9LC K309 51	IC MN1873223APB		R153		Carbon chip 47kohm 1/16W	RMC73M-1F473JR
IC702	9LC K014 51R	IC BA15218F		R201		Carbon chip 6.8kohm 1/16W	RMC73M-1F682JR
IR681	9LC J002 52U	IR SENSOR(RPM6938-SV4)		R202,203		Carbon chip 10kohm 1/16W	RMC73M-1F103JR
Q101	9LC A002 91R	Transistor DTA114EK		R204		Carbon chip 100ohm 1/16W	RMC73M-1F101JR
Q102	9LC F011 21R	Transistor 2SK161		R205		Carbon chip 4.7kohm 1/16W	RMC73M-1F472JR
Q103	9LC F011 41R	Transistor 2SC2058S(Q)		R206		Carbon chip 51ohm 1/16W	RMC73M-1F510JR
Q104	9LC A002 91R	Transistor DTA114EK		R207		Carbon chip 4.7kohm 1/16W	RMC73M-1F472JR
Q105-108	9LC A005 81R	Transistor DTC323TK		R208		Carbon chip 10kohm 1/16W	RMC73M-1F103JR
Q109	9L2 3163 61R	Transistor DTC114EK		R209		Carbon chip 3kohm 1/16W	RMC73M-1F302JR
Q701	9LC A006 91R	Transistor 2SA1037AK		R210,211		Carbon chip 4.7kohm 1/16W	RMC73M-1F472JR
Q702,703	9LC A005 81R	Transistor DTC323TK		R212	9L0 7900 51R	Carbon chip 10kohm 1/16W	RMC73M-1F103JR
Q704	9L2 3191 52	Transistor HIT5610C					Except U.S.A./Canada model
Q705	9LC A006 91R	Transistor 2SA1037AK		R212	9L0 7900 48R	Carbon chip 6.8kohm 1/16W	RMC73M-1F682JR
Q706	9L2 3163 61R	Transistor DTC114EK					U.S.A./Canada models
D101	9L2 3989 21T	Diode 1N4531T/1SS133		R213		Carbon chip 8.2kohm 1/16W	RMC73M-1F822JR
D201	9L2 3989 21T	Diode 1N4531T/1SS133		R214,215		Carbon chip 3.3kohm 1/16W	RMC73M-1F332JR
D701,702	9L2 3989 21T	Diode 1N4531T/1SS133		R216,217		Carbon chip 1kohm 1/16W	RMC73M-1F102JR
D703	9LC H019 71	LED LH5230/PI		R218,219		Carbon chip 470ohm 1/16W	RMC73M-1F471JR
FL681	9LD D000 62	FL TUBE(12-BT-110GK)		R220,221		Carbon chip 1kohm 1/16W	RMC73M-1F102JR
JK701	269 0098 006	IC GP1F32T		R222		Carbon chip 5.6kohm 1/16W	RMC73M-1F562JR
RESISTORS GROUP							
R101		Carbon chip 1kohm 1/16W	RMC73M-1F102JR	R681		Carbon film 47ohm 1/4W	RD14S2E470JB
R102		Carbon film 120ohm 1/6W	RD14S1J121JB	R682		Carbon chip 150ohm 1/16W	RMC73M-1F151JR
R103		Carbon film 100ohm 1/4W	RDF25S 101J	R683		Carbon chip 180ohm 1/16W	RMC73M-1F181JR
R104		Carbon chip 5.6kohm 1/16W	RMC73M-1F562JR	R684		Carbon chip 270ohm 1/16W	RMC73M-1F271JR
R105		Carbon chip 2.2kohm 1/16W	RMC73M-1F222JR	R685		Carbon chip 390ohm 1/16W	RMC73M-1F391JR
R106		Carbon chip 1kohm 1/16W	RMC73M-1F102JR	R686		Carbon chip 680ohm 1/16W	RMC73M-1F681JR
R107		Carbon chip 220ohm 1/16W	RMC73M-1F221JR	R687		Carbon chip 150ohm 1/16W	RMC73M-1F151JR
R108,109		Carbon chip 10kohm 1/16W	RMC73M-1F103JR	R688		Carbon chip 180ohm 1/16W	RMC73M-1F181JR
R110		Carbon chip 390ohm 1/16W	RMC73M-1F391JR	R689		Carbon chip 270ohm 1/16W	RMC73M-1F271JR
R111,112		Carbon chip 330ohm 1/16W	RMC73M-1F331JR	R690		Carbon chip 5.6kohm 1/16W	RMC73M-1F562JR
R113		Carbon chip 220ohm 1/16W	RMC73M-1F221JR	R691		Carbon chip 8.2kohm 1/16W	RMC73M-1F822JR
R114		Carbon chip 2.7kohm 1/16W	RMC73M-1F272JR	R692		Carbon chip 15kohm 1/16W	RMC73M-1F153JR
R115		Carbon chip 330ohm 1/16W	RMC73M-1F331JR	R693		Carbon chip 33kohm 1/16W	RMC73M-1F333JR
				R694		Carbon chip 82kohm 1/16W	RMC73M-1F823JR
				R695		Carbon chip 1.5kohm 1/16W	RMC73M-1F152JR
				R696		Carbon chip 2.2kohm 1/16W	RMC73M-1F222JR
				R697		Carbon chip 2.7kohm 1/16W	RMC73M-1F272JR
				R698		Carbon chip 3.9kohm 1/16W	RMC73M-1F392JR
				R701-709		Carbon chip 10kohm 1/16W	RMC73M-1F103JR
				R710		Carbon chip 15kohm 1/16W	RMC73M-1F153JR
				R711,712		Carbon chip 10kohm 1/16W	RMC73M-1F103JR
				R713,714		Carbon chip 22kohm 1/16W	RMC73M-1F223JR
				R715		Carbon chip 47kohm 1/16W	RMC73M-1F473JR
				R716,717		Carbon chip 220kohm 1/16W	RMC73M-1F224JR

Ref. No.	Part No.	Part Name	Remarks	Ref. No.	Part No.	Part Name	Remarks
R718,719		Carbon chip 8.2kohm 1/16W	RMC73M-1F822JR	C219		Electrolytic 3.3μF/50V	CE04W1H3R3MB(SSL)
R720,721		Carbon chip 12kohm 1/16W	RMC73M-1F123JR	C220		Electrolytic 22μF/50V	CE04W1H220MB(SSL)
R722,723		Carbon chip 1kohm 1/16W	RMC73M-1F102JR	C221		Ceramic 820pF/50V	CK14B1H821KB(050)
R724,725		Carbon chip 24kohm 1/16W	RMC73M-1F243JR				Asia model only
R726,727		Carbon chip 220ohm 1/16W	RMC73M-1F221JR	C221		Ceramic 330pF/50V	CK14B1H331KB(050)
R728		Carbon chip 10kohm 1/16W	RMC73M-1F103JR				Except Asia model
R729		Carbon chip 2.2kohm 1/16W	RMC73M-1F222JR	C222		Ceramic chip 0.047μF/50V	CK73MF1H473ZR
R730-743		Carbon chip 1kohm 1/16W	RMC73M-1F102JR	C223		Electrolytic 10μF/50V	CE04W1H100MB(SSL)
R744		Carbon chip 10kohm 1/16W	RMC73M-1F103JR	C224,225		Mylar film 0.047μF/50V	CQ92M1H473KB(AMZ)
R745-754		Carbon chip 100kohm 1/16W	RMC73M-1F104JR				U.S.A./Canada models
R755,756		Carbon chip 10kohm 1/16W	RMC73M-1F103JR	C224,225		Mylar film 0.033μF/50V	CQ92M1H333KB(AMZ)
RE681		Rotary encoder	EC16B24104				Except U.S.A./Canada model
CAPACITORS GROUP				C226,227		Ceramic chip 2700pF/50V	CK73MB1H272BR
C101		Mylar film 0.01μF/50V	CQ92M1H103KB(AMZ)				Europe/U.K. models
C103		Ceramic chip 22pF/50V	CC73MSL1H220JR	C228,229		Electrolytic 2.2μF/50V	CE04W1H2R2MB(SSL)
C104		Ceramic 0.047μF/25V	CK14F1H473ZB(050)	C230		Electrolytic 10μF/16V	CE04W1C100MB(SRA)
C105		Ceramic chip 100pF/50V	CK73MSL1H101JR	C232		Ceramic chip 0.01μF/50V	CK73MF1H103ZR
C106		Ceramic chip 0.01μF/50V	CK73MF1H103ZR	C233		Ceramic chip 220pF/50V	CC73MSL1H221JR
C107		Ceramic chip 0.022μF/50V	CK73MF1H223ZR	C251,252		Ceramic chip 22pF/50V	CC73MCH1H220JR
C108		Electrolytic 47μF/25V	CE04W1E470MB(SSL)				Except Asia model
C109		Electrolytic 0.47μF/50V (BP)	CE04W1H0R47BP (SMEBP)	C253		Ceramic chip 0.01μF/50V	CK73MF1H103ZR
C111		Ceramic chip 0.01μF/50V	CK73MF1H103ZR	C254		Electrolytic 47μF/6.3V	CE04W0J470MB(SRA)
C112		Electrolytic 1μF/50V	CE04W1H1R0MB (SSL)	C255		Ceramic chip 560pF/50V	CK73MSL1H561JR
C113		Ceramic chip 0.01μF/50V	CK73MF1H103ZR				Except Asia model
C114,115		Ceramic chip 100pF/50V	CK73MSL1H101JR	C256		Electrolytic 47μF/6.3V	CE04W0J470MB(SRA)
C116,117		Ceramic chip 27pF/50V	CC73MCH1H270JR				Except Asia model
C118		Ceramic 0.01μF/16V	CK14Y1C103MB	C257		Ceramic chip 0.01μF/50V	CK73MF1H103ZR
C151		Ceramic chip 0.1μF/16V	CK73MF1C104BR	C258		Electrolytic 10μF/16V	CE04W1C100MB(SRA)
C152		Ceramic chip 9.0 pF/50V	CK73MCH1H090CR				Except Asia model
C201		Electrolytic 47μF/25V	CE04W1E470MB(SSL)	C259		Ceramic chip 330pF/50V	CC73MSL1H331JR
C202-204		Ceramic chip 0.047μF/50V	CK73MF1H473ZR				Except Asia model
C205		Ceramic chip 0.01μF/50V	CK73MF1H103ZR	C681		Electrolytic 47μF/6.3V	CE04W0J470MB(SRA)
C206		Electrolytic 1μF/50V	CE04W1H1R0MB(SRA)	C682		Ceramic chip 0.01μF/50V	CK73MF1H103ZR
C207		Ceramic chip 0.01μF/50V	CK73MF1H103ZR				
C208		Electrolytic 10μF/50V	CE04W1H100MB(SSL)	C701		Ceramic chip 1000pF/50V	CK73MF1H102ZR
C209		Ceramic chip 0.047μF/50V	CK73MF1H473ZR	C702,703		Electrolytic 1μF/50V	CE04W1H1R0MB(SRA)
C210		Electrolytic 1μF/50V	CE04W1H1R0MB(SSL)	C704-707		Ceramic chip 390pF/50V	CC73MSL1H391JR
C211		Electrolytic 10μF/50V	CE04W1H100MB(SSL)	C708,709		Electrolytic 4.7μF/50V	CE04W1H4R7MB(SRA)
C212		Electrolytic 10μF/16V	CE04W1C100MB(SRA)	C710		Electrolytic 100μF/6.3V	CE04W0J101MB(SRA)
C213		Electrolytic 1μF/50V	CE04W1H1R0MB(SSL)	C711		Ceramic chip 0.01μF/50V	CK73MF1H103ZR
C214		Electrolytic 0.47μF/50V	CE04W1HR47MB(SSL)	C712,713		Electrolytic 10μF/16V	CE04W1C100MB(SRA)
C215		Electrolytic 1μF/50V	CE04W1H1R0MB(SRA)	C714		Ceramic chip 1000pF/50V	CK73MF1H102ZR
C216		Electrolytic 33μF/31.5V	CE04W1F330MB(SSL)	C715,716		Electrolytic 10μF/16V	CE04W1C100MB(SRA)
C217,218		Ceramic chip 0.047μF/50V	CK73MF1H473ZR	C717		Ceramic chip 0.01μF/50V	CK73MF1H103ZR

**PARTS LIST OF P.W.B. UNIT
CD SERVO P.W.B. UNIT ASS'Y**

Ref. No.	Part No.	Part Name	Remarks	Q'ty
OTHER PARTS GROUP				
BL001	9LB H005 32	AM RF block		1
#001	9LN J027 71	FL holder		1
#004	9LM D040 51	Shield plate (TU)	U.S.A./Canada/ Asia models	1
JK101	9LE U000 11	Antenna terminal KYD31		1
CF101	9L2 1349 92	Ceramic filter SFE10.7MA8	U.S.A./Canada/ Asia models	1
CF101	9LB N001 01	Ceramic filter SFT10.7MS2	Europe/U.K. models	1
CF102	9LB N001 11	Ceramic filter SFE10.7MS2G	U.S.A./Canada/ Asia models	1
CF102	9LB N001 01	Ceramic filter SFT10.7MS2	Europe/U.K. models	1
CN101A	9LE Y000 82	13P pin header		1
CN201	9L2 6742 62	3P MX pin post		1
CN601A	9LE D022 61	30P FFC connector base (L)		1
CN602A	9LE F069 22	9P KR-DA connector cord	L=100mm	1
CN701	9LE D017 52	30P FFC connector base		1
CN702	9LE F068 61	6P KR-DA connector cord	L=80mm	1
CN703A	9LE Y000 82	13P pin header		1
CN704A	9LE Y000 82	13P pin header		1
CN705	9LE F066 85	7P KR-DA connector cord	L=160mm	1
E001	—	Lug terminal		1
FE101	9LH H000 42	Tuner pack FE450-G01	Europe/U.K. models	1
FE101	9LH H000 41	Tuner pack FE350-A01	U.S.A./Canada/ Asia models	1
S681-696	9LF E003 01R	Tact switch		16
T201	9LB J002 52	AM IFT (LA1873)		1
T202	9LB J004 22	FM DISCRI coil		1
T203,204	9LB J004 11	LPF (19KHz)	Europe/U.K. models	1
X101	9L2 1701 32	Crystal 7.2MHz		1
X251	9L2 1701 33	Crystal 4.332MHz	Except Asia model	1
X701	9LB P001 41	Ceramic resonator	CST8.00MTW	1
KC001-007	—	Carbon chip 0ohm 1/16W	RMC73-M1F00R	7
W005	—	UL wire(BLK)	UL1007 #14S	1
W008	—	UL wire(BLK)	UL1007 #14S	1
	9LJ T082 21	Tuner/CD/Display P.W.B. Ass'y	U.S.A./Canada models	1
	9LJ T082 22	Tuner/CD/Display P.W.B. Ass'y	Europe model only	1
	9LJ T082 23	Tuner/CD/Display P.W.B. Ass'y	U.K. model only	1
	9LJ T082 26	Tuner/CD/Display P.W.B. Ass'y	Asia model only	1

Ref. No.	Part No.	Part Name	Remarks
SEMICONDUCTORS GROUP			
IC701	*	*	Refer to the conversion list
IC702	*	*	Refer to the conversion list
IC703	*	*	Refer to the conversion list
Q701	928 0023 206	Transistor 2SB709STX	
Q702	*	*	Refer to the conversion list
RESISTORS GROUP			
R701		Carbon Chip 4.7ohm 1/10W	ERJ6GEYJ4R7V
R703		Carbon chip 82kohm 1/10W	ERJ6GEYJ823V
R704		Carbon chip 1kohm 1/10W	ERJ6GEYJ102A
R705		Carbon chip 10kohm 1/10W	ERJ6GEYJ103V
R706		Carbon chip 1kohm 1/10W	ERJ6GEYJ102A
R707		Carbon chip 470kohm 1/10W	ERJ6GEYJ474V
R708		Carbon chip 150kohm 1/10W	ERJ6GEYJ154V
R709		Carbon chip 68kohm 1/10W	ERJ6GEYJ683V
R711		Carbon chip 150kohm 1/10W	ERJ6GEYJ154V
R712		Carbon chip 220ohm 1/10W	ERJ6GEYJ221V
R714		Carbon chip 120ohm 1/10W	ERJ6GEYJ121V
R717,718		Carbon chip 1kohm 1/10W	ERJ6GEYJ102A
R719		Carbon chip 0ohm 1/8W	ERJ8GEY0R00A
R720		Carbon chip 0ohm 1/10W	ERJ6GEY0R00A
R721		Carbon chip 100ohm 1/10W	ERJ6GEYJ101V
R722		Carbon chip 56kohm 1/10W	ERJ6GEYJ563V
R723		Carbon chip 1.8kohm 1/10W	ERJ6GEYJ182V
R724		Carbon chip 33kohm 1/10W	ERJ6GEYJ333V
R725		Carbon chip 4.7kohm 1/10W	ERJ6GEYJ472V
R726		Carbon chip 47kohm 1/10W	ERJ6GEYJ473V
R727		Carbon chip 8.2kohm 1/10W	ERJ6GEYJ822V
R728		Carbon chip 10kohm 1/10W	ERJ6GEYJ103V
R731		Carbon chip 8.2kohm 1/10W	ERJ6GEYJ822V
R735,736		Carbon chip 100ohm 1/10W	ERJ6GEYJ101V
R744		Carbon chip 10kohm 1/10W	ERJ6GEYJ103V
R745		Carbon chip 1.5Mohm 1/10W	ERJ6GEYJ155V
R748		Carbon chip 1.8kohm 1/10W	ERJ6GEYJ182V
R749		Carbon chip 6.8kohm 1/10W	ERJ6GEYJ682V
R750,751		Carbon chip 47kohm 1/10W	ERJ6GEYJ473V
R752		Carbon chip 22ohm 1/8W	ERJ8GEYJ220V
R770,771		Carbon chip 1.5Mohm 1/10W	ERJ6GEYJ155V
R772		Carbon chip 27kohm 1/10W	ERJ6GEYJ273V
RJ701-710		Carbon chip 0ohm 1/8W	ERJ8GEY0R00A
RJ711		Carbon chip 0ohm 1/10W	ERJ6GEY0R00A
RJ713		Carbon chip 0ohm 1/10W	ERJ6GEY0R00A
RJ714-717		Carbon chip 0ohm 1/8W	ERJ8GEY0R00A
RJ721-731		Carbon chip 0ohm 1/10W	ERJ6GEY0R00A

**CD SERVO P.W.B. UNIT ASS'Y
Conversion List**

Ref. No.	Part No.	Part Name	Remarks
CAPACITORS GROUP			
C701		Capacitor 33µF/6.3V	ECEA0JKA3301
C702		Capacitor 0.1µF/25V	ECUZNE104MBN
C703		Capacitor 100µF/6.3V	ECEA0JKA1011
C704,705		Capacitor 0.1µF/25V	ECUZNE104MBN
C706		Capacitor 2700pF/50V	ECUV1H272KBN
C707		Capacitor 0.027µF/25V	ECUV1E273KBN
C708		Capacitor 4700pF/50V	ECUE1H472KBN
C709		Capacitor 0.047µF/16V	ECUE1C473KBN
C710		Capacitor 1800pF/50V	ECUV1H182KBN
C711,712		Capacitor 0.1µF/25V	ECUMNE104ZFN
C713		Capacitor 0.1µF/16V	ECUV1C104MBM
C714		Capacitor 100µF/6.3V	ECEA0JKA1011
C716		Capacitor 560pF/50V	ECUE1H561KBN
C717		Capacitor 0.1µF/25V	ECUMNE104ZFN
C718		Capacitor 0.22µF/16V	ECUVNC224KBN
C721,722		Capacitor 10pF/50V	ECUV1H100DCN
C723		Capacitor 220µF/10V	ECEA1AKA2211
C724		Capacitor 0.1µF/16V	ECUV1C104MBM
C725,726		Capacitor 1000pF/50V	ECUE1H102KBN
C730		Capacitor 0.1µF/25V	ECUMNE104ZFN
C731,732		Capacitor 220µF/6.3V	ECEA0JKA2211
C733		Capacitor 0.1µF/25V	ECUZNE104MBN
C734		Capacitor 220µF/10V	ECEA1AKA2211
C735-737		Capacitor 0.1µF/25V	ECUMNE104ZFN
C738		Capacitor 0.15µF/16V	ECUV1C154KBN
C742		Capacitor 0.027µF/25V	ECUV1E273KBN
C743		Capacitor 0.1µF/25V	ECUMNE104ZFN
C744		Capacitor 8200pF/25V	ECUE1E822KBN
C745		Capacitor 1000pF/50V	ECUE1H102KBN
C747		Capacitor 2200pF/50V	ECUE1H222KBN
C748		Capacitor 470pF/50V	ECUV1H471KBN
C749		Capacitor 0.1µF/25V	ECUZNE104MBN
C750		Capacitor 0.1µF/16V	ECUV1C104MBM
C751		Capacitor 0.1µF/25V	ECUZNE104MBN
C752		Capacitor 1500pF/50V	ECUE1H152KBN
C753		Capacitor 470pF/50V	ECUV1H471KBN
OTHER PARTS GROUP			
CN701	928 0054 039	Socket (16P)	1
CN702	928 0085 008	Connector (30P)	1
L701-705	928 0055 407	Coil	5
S701	*	Switch	Refer to the conversion list 1
X701	928 0084 902	Oscillator	1
CP790	928 0086 609	Connector (6P)	1

Model	RD-DRL004-M RD-DRL004-C RD-DRL008-M	RD-DRL005-M
SERVO UNIT ASS'Y		
IC701	AN8835SBE1 928 0084 601	AN8837SBE1 928 0086 007
IC702	MN662741RPA 928 0084 708	MN662741RPA 928 0084 708
IC703	AN8389SE1 928 0084 805	AN8780NSBE1 928 0086 104
Q702	—	DTC114YKA146 928 0086 308
S701	RSM0006-P 928 0055 300	RSH1A043-U 928 0086 201

IC001-003 size Size 27

EXPLODED VIEW

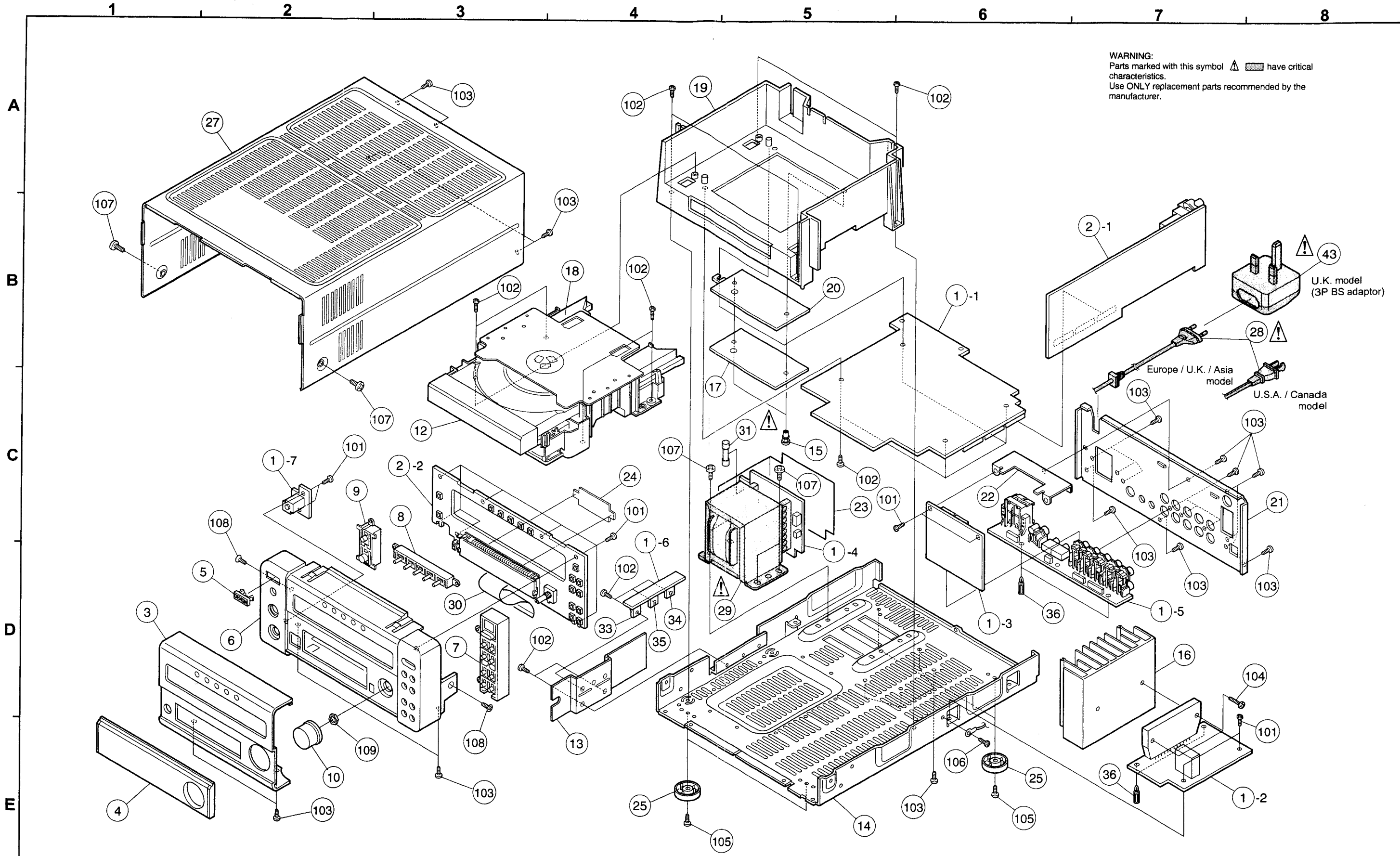

PARTS LIST OF EXPLODED VIEW

Ref. No.	Part No.	Part Name	Remarks	Q'ty	Ref. No.	Part No.	Part Name	Remarks	Q'ty
1	Note	Main P.W.B. Ass'y		1	★ 41	9L9 5634 44	Excel tube L=90	Except U.S.A./ Canada model	1
1-1		Main unit		(1)	★ 42	9L3 9737 31	Bar lok tie	Except U.S.A./ Canada model	2
1-2		Power amp unit		(1)	43	9LE P000 62	3P BS adaptor	U.K. model only	1
1-3		Selector unit		(1)	★ 44	—	Origin label (E2/EK)	Europe/U.K. models	
1-4		Trans unit		(1)	★ 45	—	Fuse caution label	U.S.A./Canada models	1
1-5		Jack unit		(1)	★ 46	—	Number sheet		1
1-6		REG unit		(1)	★ 47	—	Caution label	U.S.A./Canada models	1
1-7		H/P unit		(1)	★ 48	—	Origin label	Asia model only	1
2	Note	Tuner/CD/Display P.W.B. Ass'y		1	★ 49	—	Manufactured label	U.S.A./Canada models	1
2-1		Tuner/CD unit		(1)	★ 50	—	Class label	Except U.S.A./ Canada model	1
2-2		Display unit		(1)	SCREWS & NUTS				
3	Note	Front panel AL		1	101	9L8 6914 10	Screw 3x10 BT BIND		12
4	9LP H056 31	Clear panel		1	102	9L8 6914 08	Screw 3x8 BT BIND		17
5	9LP U003 31	DENON badge		1	103	9L8 6994 10	Screw 3x10 BT BIND B		25
6	9LP H056 41	Front panel		1	104	9L8 6914 14	Screw 3x14 BT BIND		2
7	Note	Button (play)		1	105	9L8 6994 08	Screw 3x8 BT BIND		4
8	Note	Button (tuner)		1	106	9L8 6714 04	Screw 3x4 DT BIND		2
9	Note	Button (power)		1	107	9L8 6796 06	Screw 4x6 DT BIND B		6
10	Note	Volume knob Ass'y		1	108	9L8 6014 08	Screw 3x8 DT FLAT HEAD		2
★ 11	9L4 8583 36	Spacer (8mm x 60mm)	Except Asia model	1	109	9LM K002 46	NUT M9x0.75		1
12	Note	Loader panel		1	PACKING & ACCESSORIES (Not included EXPLODED VIEW.)				
13	9LM B003 71	Heat sink (P)		1	201	Note	Carton box		1
14	9LN Q060 11	Chassis		1	202	9LS P052 01	Cushion		2
15	9LM L003 42	Push rivet		2	203	9L3 6275 65	Pory sack	for AC cord	1
16	9LM B003 31	Heat sink		1	204	Note	Pory sack	for accessories	1
17	9LM N016 81	Holder sheet		1	205	9L2 7593 41	AM loop antenna		1
18	9LU C005 02	CD mecha.		1	206	9LE F021 33	FM antenna connector		1
19	9LN J027 81	Mecha. holder		1	207	9LH L009 03	Remote control unit	RC-846	1
20	9LM D043 41	Holder plate		1	208	Note	Instruction manual		1
21	Note	Rear plate		1	209	—	Origin label	Asia model only	1
22	9LN A282 41	P.W.B. support		1	210	—	UPC label	U.S.A./Canada models	1
23	9LM E015 11	Shield sheet (TRANS)		1	211	—	EAN label(E2)	Europe model only	1
24	9LM E015 21	Shield sheet (DISPLAY)		1	212	—	EAN label(EK)	U.K. model only	1
25	9LQ J003 91	Foot		4	213	—	Warranty card	U.S.A./Canada models	1
★ 26	9LM S002 11	Felt		4					
27	9LQ A011 01	Top cover		1					
△ 28	Note	AC cord		1					
△ 29	Note	Power trans.		1					
30	9LE K009 71	30P FFC cable (L=100)	CN701	1					
△ 31	Note	Fuse	F001	1					
★ 32	9LE J006 11	Excel tube L=110		1					
33	9LC P024 12	IC KIA7806	IC001	1					
34	9L2 0046 03	IC PQ12RA1	IC002	1					
35	9LC P024 13	IC KIA7808	IC003	1					
36	9LM L002 51	Mini P.W.B. post		4					
★ 37	9L8 6914 10	Screw 3x10 BT BIND	Except U.S.A./ Canada model	1					
★ 38	9L0 8900 43M	Ceramic 0.01 F/16V	CK14Y1C103MB Except U.S.A./ Canada model	1					
★ 39	9L9 4511 40	UL tube L=25mm #12	Except U.S.A./ Canada model	1					
★ 40	—	Lug terminal	Except U.S.A./ Canada model	1					

ADDENDUM PARTS LIST

PARTS LIST OF EXPLODED VIEW

Ref. No.	Part Name	Part No.	Part No.	Part No.	Part No.
		U.S.A/Canada	Europe	U.K.	Asia
1	Main P.W.B. Ass'y	9LJ T082 31	9LJ T082 32	9LJ T082 33	9LJ T082 36
2	Tuner/CD/Display P.W.B. Ass'y	9LJ T082 21	9LJ T082 22	9LJ T082 23	9LJ T082 26
3	Front panel AL	9LP M062 94	9LP M062 94	9LP M062 94	9LP M062 92
7	Button (play)	9LP C028 41	9LP C028 41	9LP C028 41	9LP C028 42
8	Button (tuner)	9LP C028 51	9LP C028 51	9LP C028 51	9LP C028 52
9	Button (power)	9LP C022 41	9LP C022 41	9LP C022 41	9LP C022 42
10	Volume knob Ass'y	9LP A000 21	9LP A000 21	9LP A000 21	9LP A000 22
12	Loader panel	9LP H056 51	9LP H056 51	9LP H056 51	9LP H056 52
21	Rear plate	9LQ A010 94	9LQ A010 91	9LQ A010 91	9LQ A010 93
△ 28	AC cord	9LE V007 01	9LE V007 03	9LE V007 03	9LE V007 03
△ 29	Power trans.	9LB T010 83	9LB T010 81	9LB T010 81	9LB T010 81
△ 31	Fuse T500mA (F001)	—	9L2 7277 24	9L2 7277 24	9L2 7277 24
△ 31	Fuse 1.25A 125V (F001)	9L2 7224 12	—	—	—
PACKING AND ACCESSORIES					
201	Carton box	9LS G078 31	9LS G078 32	9LS G078 32	9LS G078 33
204	Pory sack	9L3 6402 14W	9L3 6402 14W	9L3 6402 13W	9L3 6402 14W
208	Instruction manual	9LQ R257 11	9LQ R257 12	9LQ R257 12	9LQ R257 14

EXPLODED VIEW OF CD MECHANISM UNIT

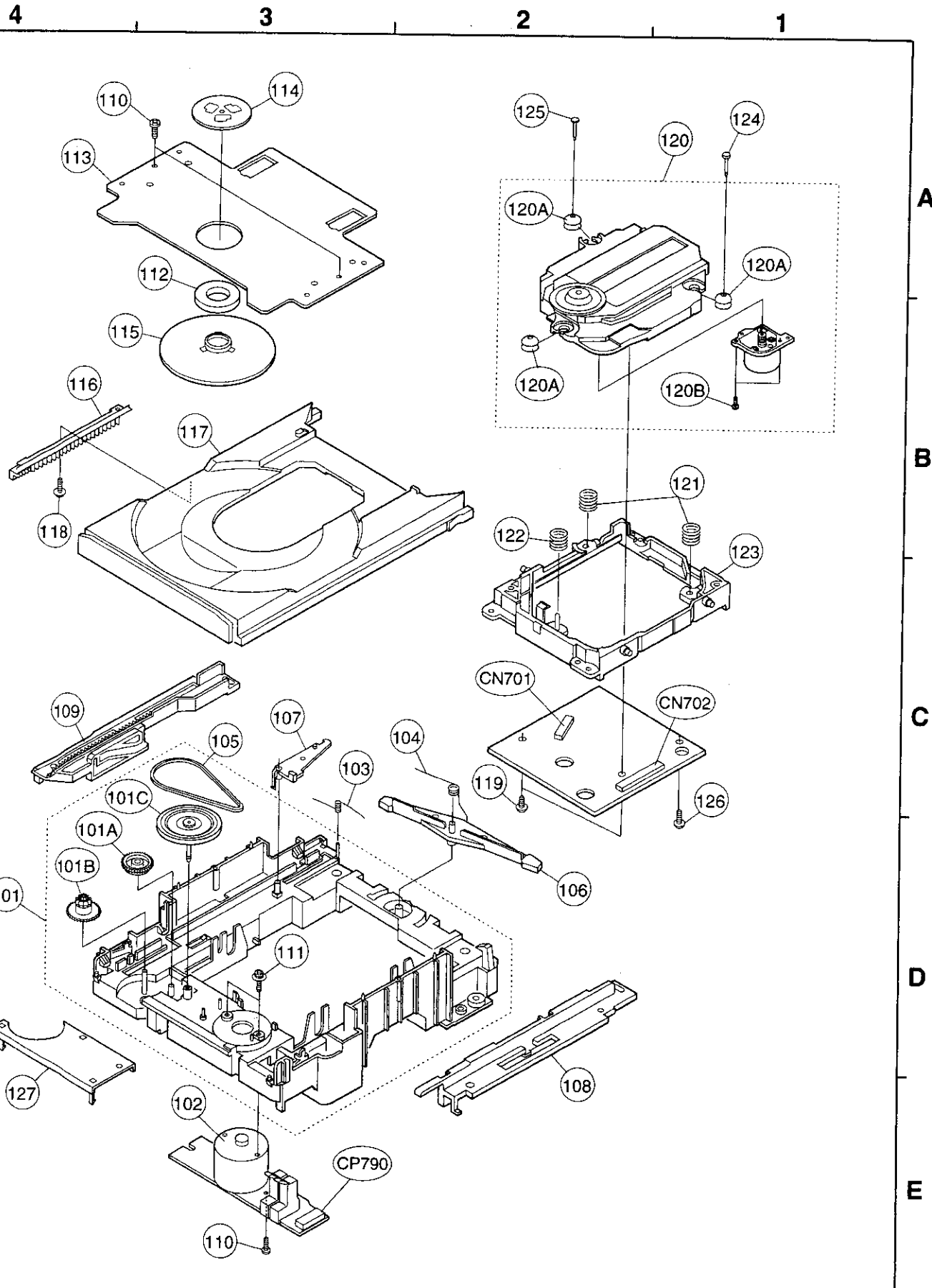

PARTS LIST OF CD MECHANISM UNIT

Ref. No.	Part No.	Part Name	Remarks	Q'ty
101	928 0082 001	Loading mecha. chassis Ass'y	RFKJXDT07-K	1
101A	928 0084 300	Intermediate gear	RDG0142	1
101B	928 0084 313	Drive gear (A)	RDG0193	1
101C	928 0084 326	Intermediate pulley	RDP0065	1
102	928 0082 108	Loading motor Ass'y	REM0019	1
103	928 0082 205	Lock lever spring	RME0063	1
104	928 0082 302	Assist spring	RME0087	1
105	928 0082 409	Belt	RMG0158	1
106	928 0082 506	Conversion lever	RML0349	1
107	928 0082 603	Lock lever	RML0178-1	1
108	928 0082 700	Slide plate (2)	RMM0059-1	1
109	928 0082 807	Slide plate (1)	RMM0079-1	1
110	928 0082 904	Screw	XTN26+6G	3
111	928 0083 000	Screw	XYN2+F6FZ	2
112	928 0083 107	Magnet	RHM245ZA	1
113	928 0086 706	Clamp plate Ass'y	RFKNLCH530EA	1
114	928 0083 301	Fixed plate	RMR0334	1
115	928 0083 408	Magnet holder Ass'y	RXQ0380	1
116	928 0083 505	Drive gear (B) Ass'y	RFKNLPG440-K	1
117	928 0083 602	Disk tray	RGQ0144-K	1
118	928 0083 709	Screw	RHD20009-1	1
119	928 0050 499	Screw	XTV2+6G	2
Δ 120	928 0083 806	Traverse deck Ass'y	RAE0152Z	1
120A	928 0049 808	Floating rubber	SHGD113-1	3
120B	934 0002 905	Screw	SNSD38	2
121	928 0083 903	Floating spring (1)	RME0109	2
122	928 0083 916	Floating spring (2)	RME0142	1
123	928 0084 009	Traverse chassis	RMR0698-K	1
124	928 0084 106	Traverse fixed pin (1)	RMS0123-1	1
125	928 0084 119	Traverse fixed pin (2)	RMS0350	1
126	928 0083 013	Screw	XTN2+6G	1
127	928 0084 203	Belt cover	RMK0255	1
CN701	928 0054 039	Socket (16P)	RJU035T016-1	1
CN702	928 0085 008	Connector (30P)	RJSA4230	1
CP790	928 0086 609	Connector (16P)	RJP6G17ZA	1

WIRING DIAGRAM

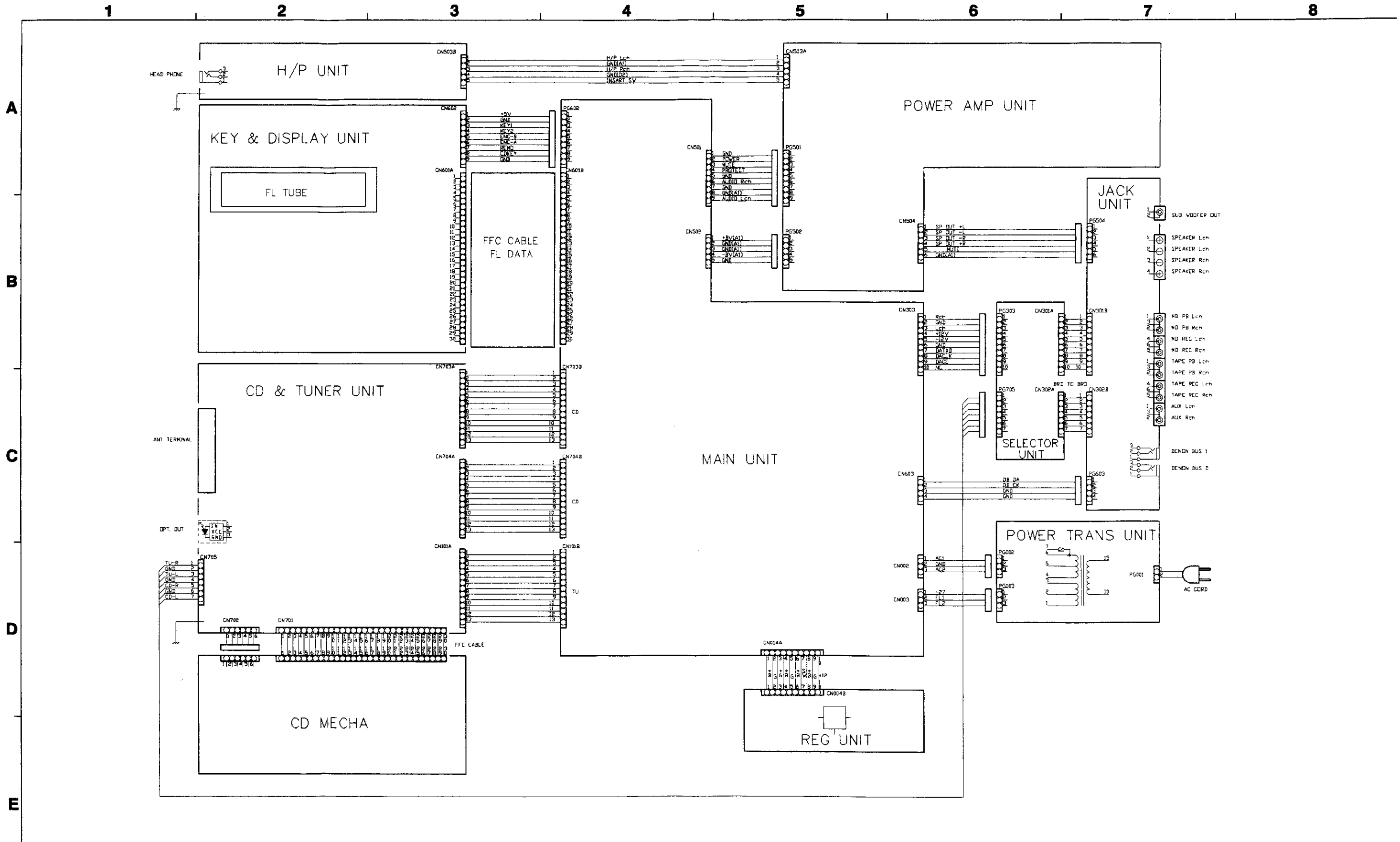

REV	EURD	USA
R617	X	X
R614	X	X
R618	X	X
R615	X	X
R619	X	X

PT001 (POWER TRANS)	R001	C631
722413	P#BT010B2	X X
727721	P#BT010B1	X O
727721	P#BT010B5	X O
722413	P#BT010B3	O X

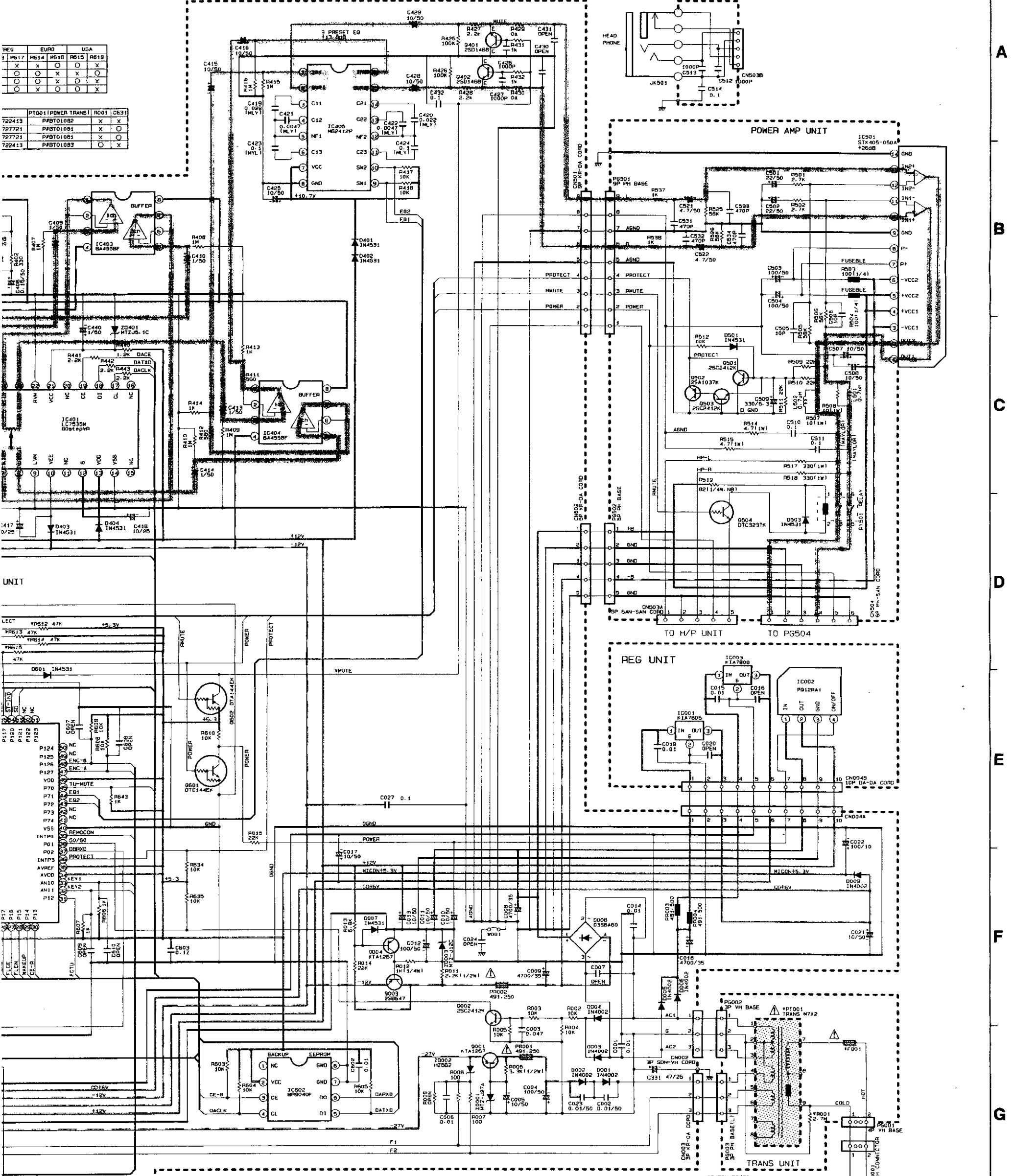

NOTICE
 ALL RESISTANCE VALUES IN OHM. k=1,000 OHM M=1,000,000 OHM
 ALL CAPACITANCE VALUES IN MICRO FARAD. P=MICRO-MICRO FARAD
 EACH VOLTAGE AND CURRENT ARE MEASURED AT NO SIGNAL INPUT
 CONDITION.
 CIRCUIT AND PARTS ARE SUBJECT TO CHANGE WITHOUT PRIOR
 NOTICE.

WARNING:
 Parts marked with this symbol  have critical characteristics.
 Use ONLY replacement parts recommended by the manufacturer.

CAUTION:
 Before returning the unit to the customer, make sure you make either (1) a
 leakage current check or (2) a line to chassis resistance check. If the leakage
 current exceeds 0.5 milliamps, or if the resistance from chassis to either side
 of the power cord is less than 460 kohms, the unit is defective.

WARNING:
 DO NOT return the unit to the customer until the problem is located and
 corrected.

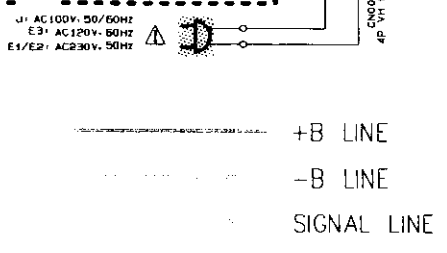

A
 B
 C
 D
 E
 F
 G
 H

SCHEMATIC DIAGRAMS (2/2)

1 2 3 4 5 6

A
B
C
D
E
F
G
H

**TUNER PMB ASS'Y UNIT TABLE OF DIFFERENCE
TUN. DISP (CIRCUIT)**

DI/DI	CF101	CF102	FE101	T203 T204	J56/59 C226 C227	R232	C224 C225	C221	A- BLOCK	C204
1 IAT E3	SFE10.7 NA-B	SFE10.7 NS26-A	3-TUNE	X	X	X	5.8K 0.047	330P	X	0.05
2 3 IB, CIE2	SFE10.7 NS2-A	SFE10.7 NS2-A	4-TUNE	X	X	X	10K 0.033	330P	X	0.047
6 IF1 E1	SFE10.7 NA-B	SFE10.7 NS26-A	3-TUNE	X	X	X	10K 0.033	B20P	X	0.01
8 IM1 J	SFE10.7 NA-B	SFE10.7 NS26-A	3-TUNE	X	X	X	5.8K 0.033	B20P	X	0.01
NOTE	BAND-WIDTH	FRONT END	FM 19KHZ LPF		MUTE-BAND- WIDTH	DE-EMPHASIS	SEPARATION	RDS		

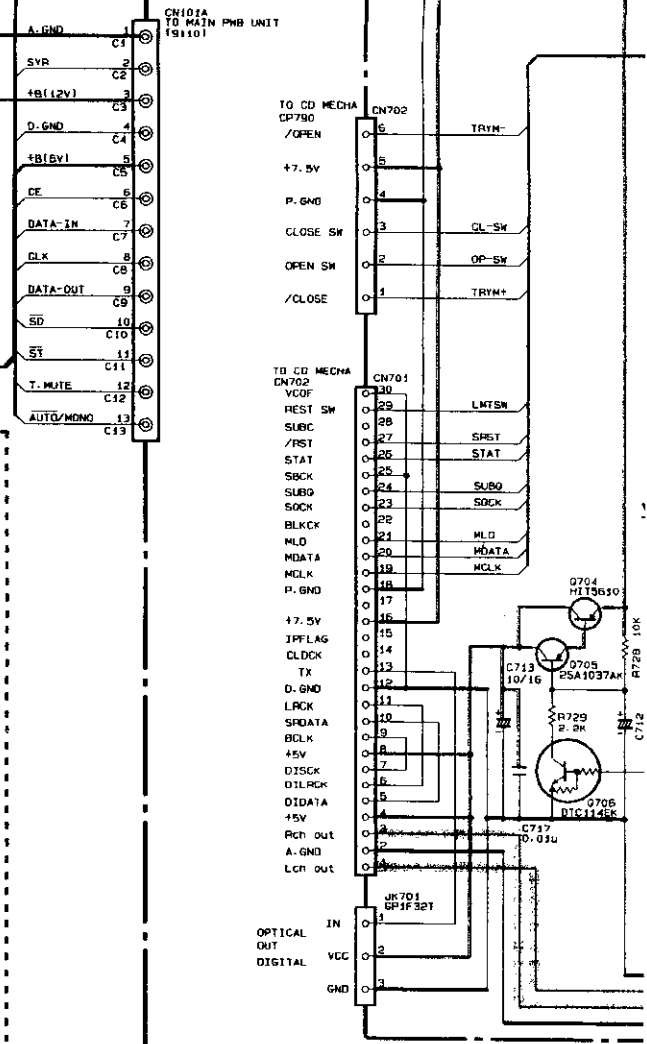
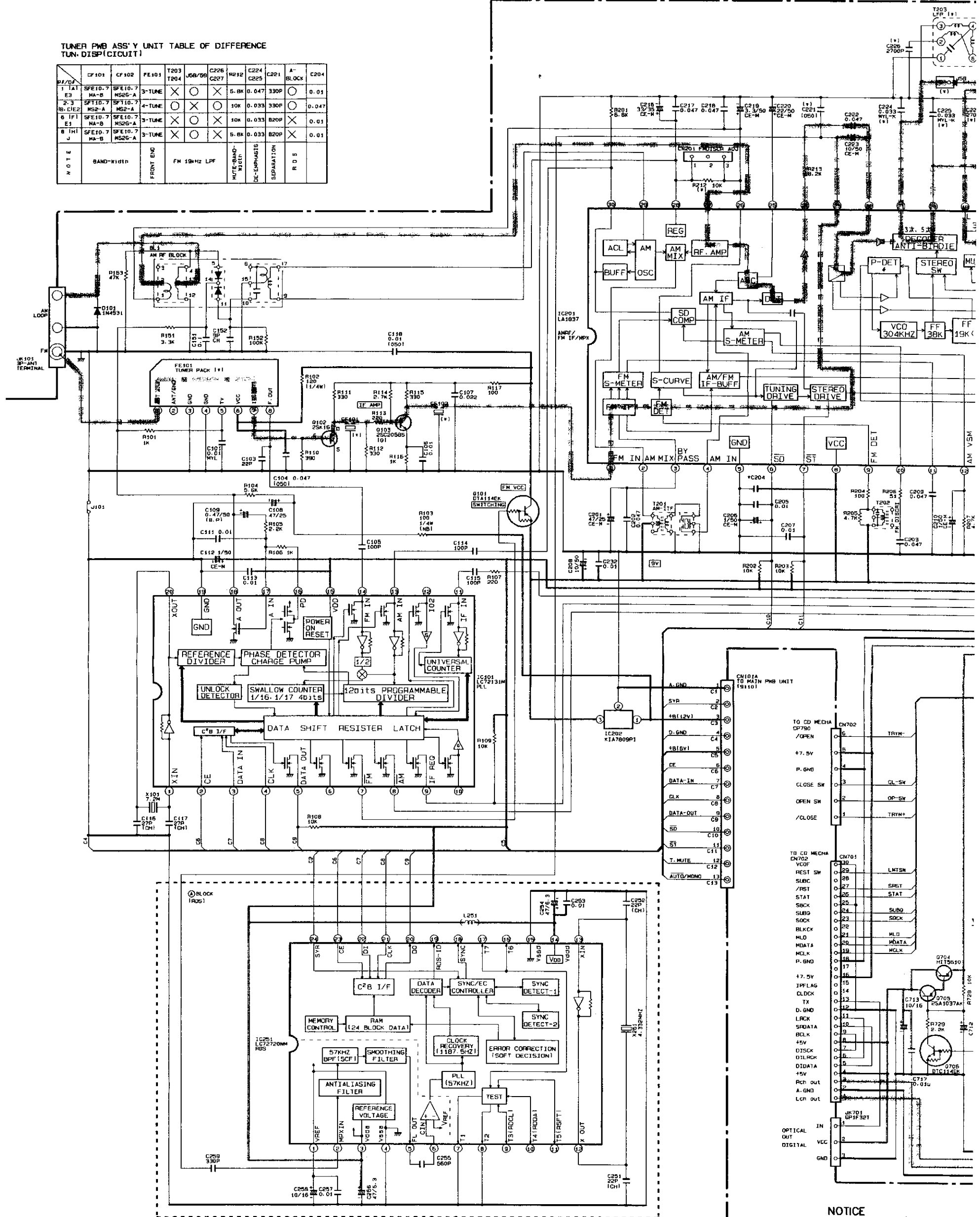

NOTICE
ALL RESISTANCE VALUES IN OHM
ALL CAPACITANCE VALUES IN MI
EACH VOLTAGE AND CURRENT A
CONDITION.
CIRCUIT AND PARTS ARE SUBJEC
NOTICE.

DISPLAY UNIT

A

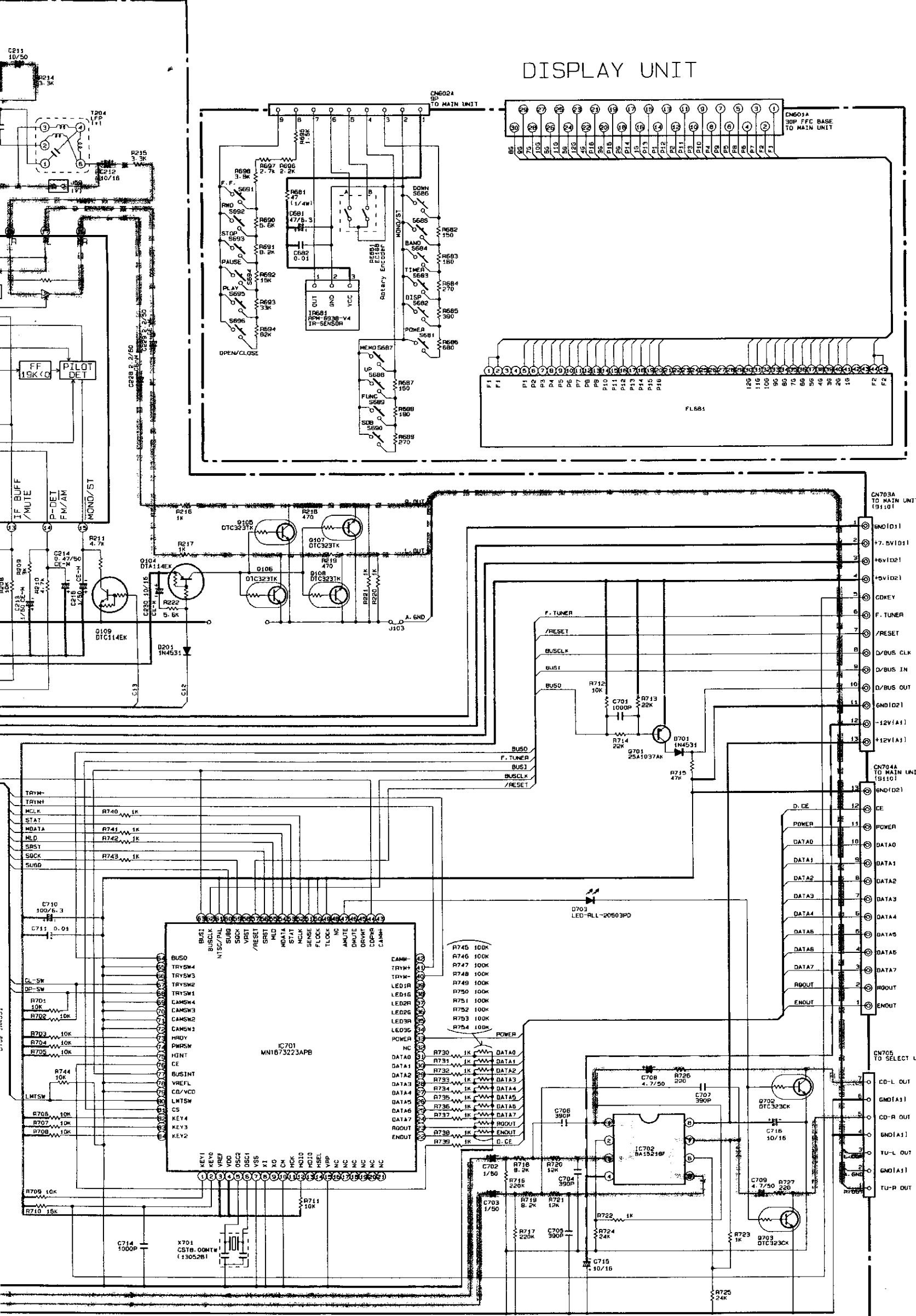

k=1,000 OHM M=1,000,000 OHM
 0 FARAD. P=MICRO-MICRO FARAD
 MEASURED AT NO SIGNAL INPUT
 TO CHANGE WITHOUT PRIOR

WARNING:
 Parts marked with this symbol have critical characteristics.
 Use ONLY replacement parts recommended by the manufacturer.

CAUTION:
 Before returning the unit to the customer, make sure you make either (1) a leakage current check or (2) a line to chassis resistance check. If the leakage current exceeds 0.5 milliamps, or if the resistance from chassis to either side of the power cord is less than 460 kohms, the unit is defective.

WARNING:
 DO NOT return the unit to the customer until the problem is located and corrected.

- +B LINE
- B LINE
- AM SIGNAL LINE
- FM SIGNAL LINE
- CD SIGNAL LINE