

# DENON

Hi-Fi Personal Component System

**SUPPLEMENT**

## SERVICE MANUAL MODEL D-M7 PERSONAL COMPONENT SYSTEM

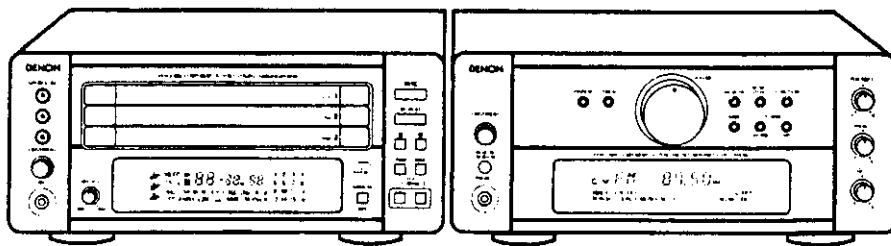

Unit No. UDRA-M7 (Receiver)

Unit No. UDCM-M7 (Compact Disc Player)

This service manual is supplement for already issued service manual of D-M7.  
For servicing, refer to the both manuals.

### — TABLE OF CONTENTS —

#### Compact Disc Section (UDCM-M7)

PARTS LIST OF CD MECHANISM UNIT .....	2
EXPLODED VIEW OF CD MECHANISM .....	3
ADDENDUM PARTS LIST OF EXPLODED VIEW .....	4

#### Receiver Section (UDRA-M7)

ADDENDUM PARTS LIST OF EXPLODED VIEW .....	4
--	---

● Some illustrations using in this service manual are slightly different from the actual set.

# NIPPON COLUMBIA CO., LTD.

## CD PLAYER SECTION

## PARTS LIST OF CD CHANGER MECHANISM UNIT (Part No. : 9LU C004 51)

Ref. No.	Part No.	Part Name	Remarks	Q'ty	Ref. No.	Part No.	Part Name	Remarks	Q'ty
<b>LOADER MECH. SECTION</b>					<b>TRAVESER SECTION</b>				
101	937 0233 003	Main base	1242070025	1	1	937 0121 005	Middle gear	1102810126	1
102	937 0233 100	Top board	1242000146	1	2	937 0121 102	Drav gear	1102810127	1
103	937 0233 207	Cam guide roller	1242870011	3	3	937 0121 209	Guide railroller	1102480681	1
104	937 0233 304	Drive pulley	1102860025	2	4	937 0121 306	Guide shaft	1102900223	1
105	937 0233 401	Idler gear	1242810041	1	5	937 0121 403	Gum cushion (gray)	1303260448	2
106	937 0233 508	Cam gear	1242810042	1	6	937 0227 103	Pickup unit	1306170020	1
107	937 0233 605	Middle gear	1242810043	1	7	937 0164 305	Gum cushion (green)	1103260278	1
108	937 0233 702	Tray idler gear	1242810046	12	8	937 0164 208	Gum cushion (red)	1103260275	1
109	937 0233 809	Main cam	1242410001	1	9	937 0150 607	Chassis with motor Ass'y	1106300208	1
110	937 0233 906	Front switch lever	1242480078	2	10	937 0122 004	Slide motor Ass'y	1106300207	1
111	937 0234 002	Rear switch lever Ass'y	1242480115	2	11	937 0122 208	Limit switch	1105300522	1
112	937 0234 109	Tray lock lever	1242480080	3	51	937 0121 801	Screw 2.6x6	1109700937	2
113	937 0234 206	Mecha holder	1243450005	1	52	937 0121 814	Screw 2x5	1109700938	2
114	937 0234 303	Stabilizer holder	1243450006	1	53	937 0121 827	Screw 2x3	1309701564	2
115	937 0234 400	Stabilizer	1242140101	1	54	937 0121 908	Cut washer	1109900315	1
116	937 0234 507	Mecha holder guide	1243450004	1			φ1.5xφ3.8x0.25mm		
119	937 0234 604	Guide tray	1241100051	3					
120	937 0234 701	Disk tray	1241100052	3					
121	937 0234 808	Switch angle	1242000147	1					
122	937 0234 905	Tray change shaft	1242900077	1					
123	937 0235 001	Tray switch spring	1242580117	4					
124	937 0235 108	Tray lock lever spring	1242580119	3					
125	937 0235 111	Disk stop spring	1242580118	1					
126	937 0235 205	Tray drive belt	1242710003	1					
127	937 0235 302	Cam drive belt	1242710004	1					
128	937 0235 409	Magnet	1103730019	1					
129	445 0033 005	Nylon band (L=80mm)	1309330057	2					
130	937 0235 506	Rubber sheet	1243520009	1					
131	937 0235 603	Mecha holder angle	1242000192	1					
132	937 0235 700	Change box	1242070027	1					
133	937 0235 807	Center gear	1242810044	1					
134	937 0235 904	Center tray gear	1242810045	3					
135	937 0236 000	Tray drive gear	1242810047	6					
136	937 0236 107	Tray change lever	1242480074	3					
137	937 0236 204	Top joint lever	1242480075	1					
138	937 0236 301	Middle joint lever	1242480076	1					
139	937 0236 408	Bottom joint lever	1242480077	1					
140	937 0236 602	Motor Ass'y	1246300041	1					
			for main cam						
141	937 0236 602	Motor Ass'y	1246300041	1					
			for tray						
142	937 0236 709	Cam switch	1245300022	2					
143	937 0041 606	Tray switch	1305301248	4					
201	937 0236 505	Screw 2.6x4	1309700139	4					
202	937 0236 518	Screw 2x7	1429700216	3					
203	937 0236 521	Screw 2x6	1429700120	3					
204	937 0182 947	Screw 2.6x12	1429700072	4					
205	937 0231 047	Screw with washer 2.6x10	1129700192	4					

## Mechanism Section

(Follow the procedure below in reverse order when reassembling)

### 1. Traverse Mecha. Ass'y

- (1) Take off Top Board by removing 2 screws ①. (Fig. A)
- (2) Pull up Tray Change Shaft, and remove Top, Middle and Bottom Joint Levers. (Fig. B)
- (3) Lower the Traverse Mecha. by turning Main Cam or Cam Gear to the arrow direction (counterclockwise) to disengage chucking of Disc Tray, and put it in Guide Tray. (Fig. A)
- (4) Pull out the Tray part with pressing the front of Change Lever as shown with the arrow A ~ C in turn from the top. (Fig. A)
- (5) Turn the Main Cam or Cam Gear until it stops turning as shown in the arrow (clockwise). (Fig. B)
- (6) Raise Stabilizer Holder with pressing its side hook and release the hook. (Fig. C)
- (7) Turn the Main Cam or Cam Gear again to the arrow direction (clockwise), and align recesses of the Main Cam with projections of Mecha. Holder. (Fig. B, D)
- (8) Pull up the Stabilizer Holder to take it off. (Fig. C)
- (9) Remove screw ② to take off Mecha. Holder Guide. (Fig. C)
- (10) Remove 2 screws ③ to take off Mecha. Holder Angle. (Fig. D)
- (11) Pull the Traverse Mecha. Ass'y apart after checking that the projections of the Mecha. Holder correspond with the recesses of the Main Cam. (Fig. D)

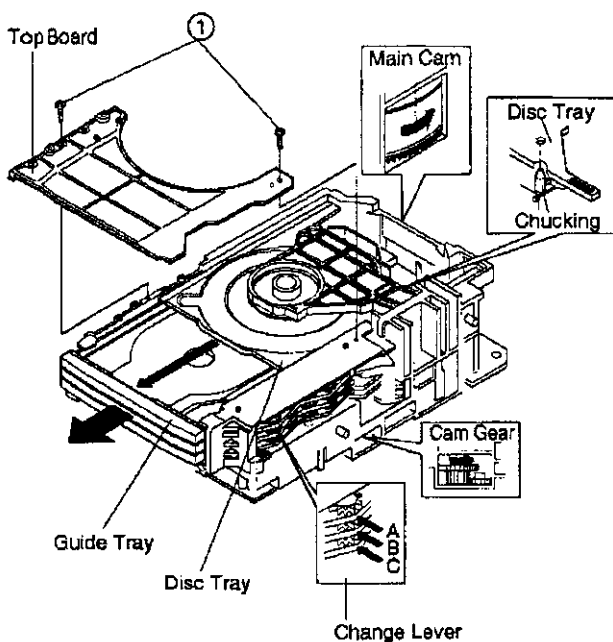

Fig. A

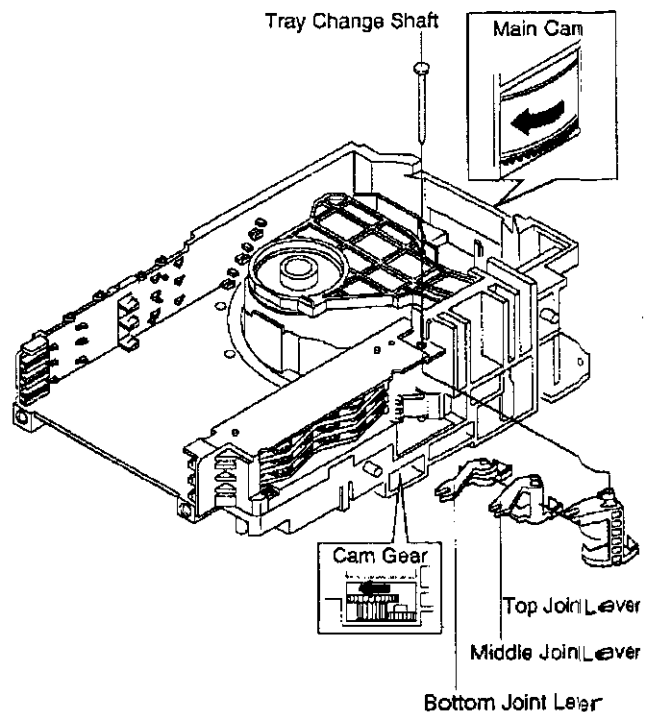

Fig. B

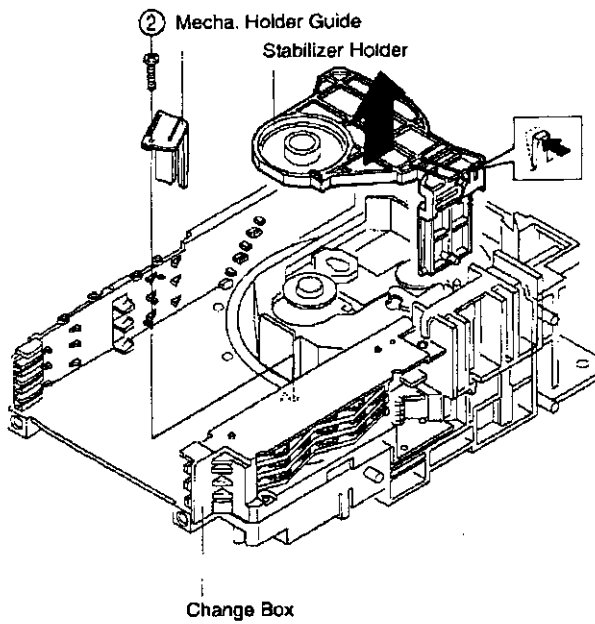

Fig. C

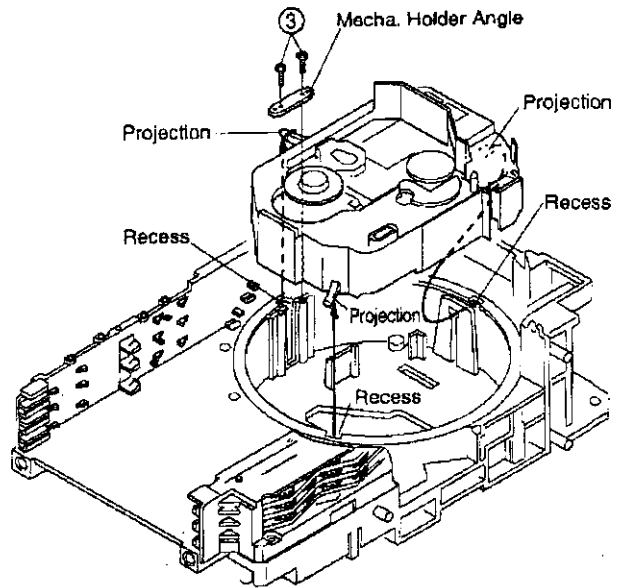
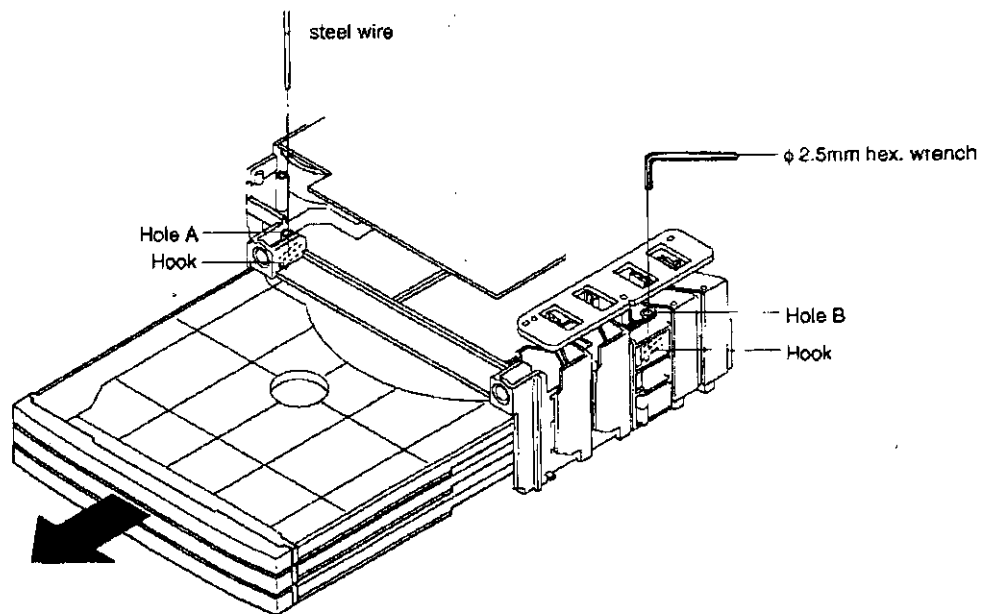

Fig. D

## 2. Tray 1 ~ 3

- (1) Turn the CD Mecha. over.
  - (2) Insert a steel wire or eyelet into the hole A, and  $\phi 2.5\text{mm}$  hex. wrench into the hole B through P.W.B. gap to release both hooks at once, then pull the Tray 3 apart as shown in fig.
- \* Be careful as the hooks may be broken if pushed hard.
  - \* As to releasing the hole B hook for the Tray 1 and 2, finger pushing through side openings is possible.



### 3. Change Box

Remove 4 screws ④ and pull up the Change Box.

### 4. Motor P.W.B.

- (1) Remove 2 screws ⑤ from the P.W.B.
- (2) Detach the P.W.B. by removing 4 screws ⑥ and 3 hooks.

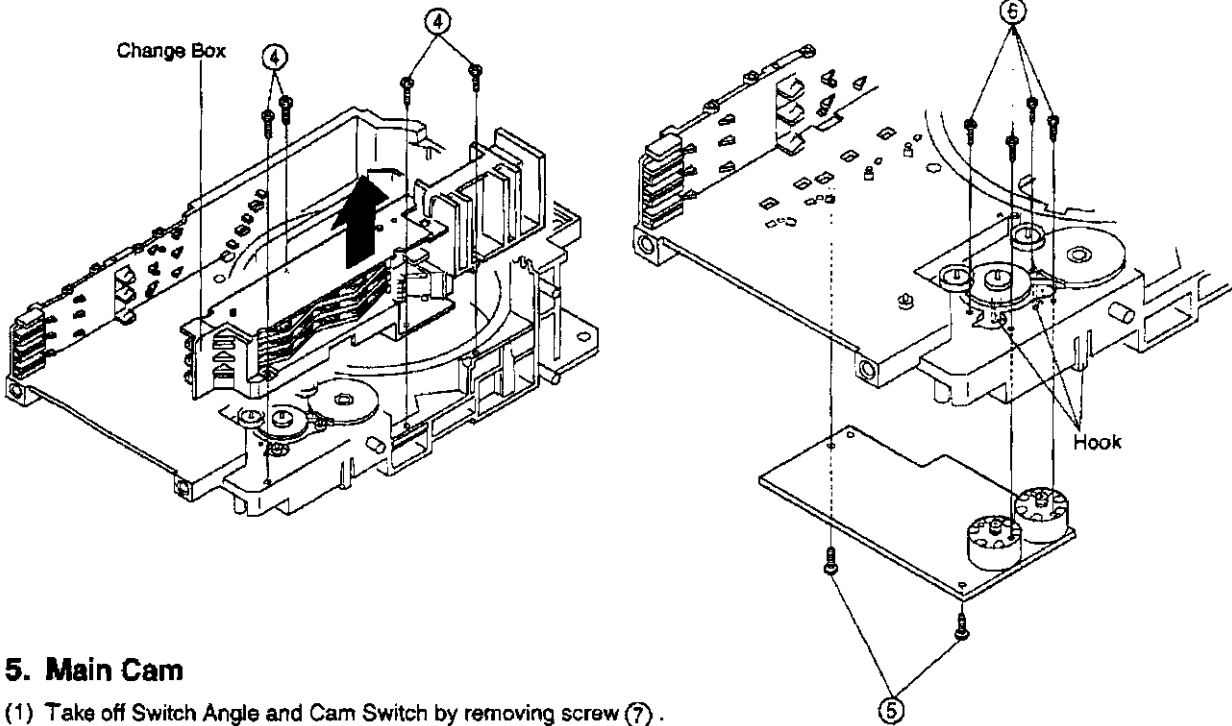

### 5. Main Cam

- (1) Take off Switch Angle and Cam Switch by removing screw ⑦.
  - (2) Pull the Main Cam apart in the arrow direction.
- \* Cord colors of the Switch Angle are red, brown, orange, green, yellow and blue from the top.

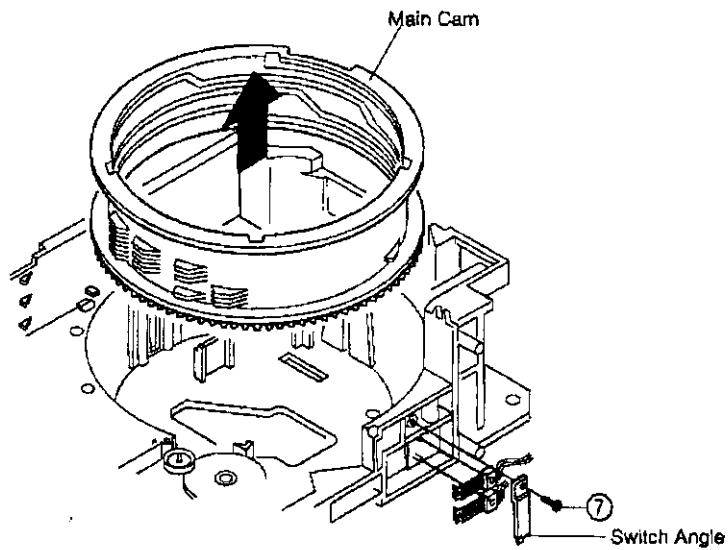



# DENON

**DENON**  
ELECTRONIC G.M.B.H.  
Halskestraße 32 · 40880 Ratingen

Hi-Fi Personal Component System

## SERVICE MANUAL MODEL D-M7 PERSONAL COMPONENT SYSTEM

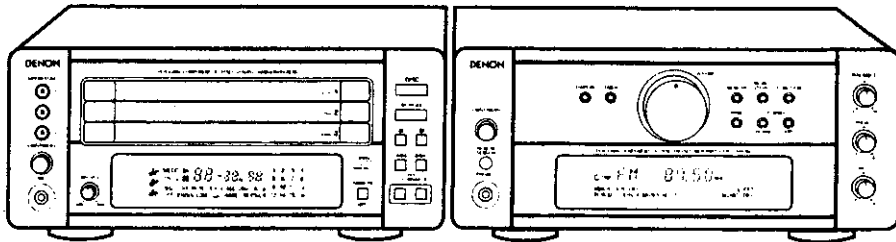
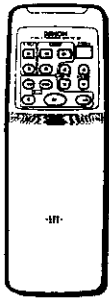

Unit No. UDRA-M7 (Receiver)

Unit No. UDCM-M7 (Compact Disc Player)

### — TABLE OF CONTENTS —

OPERATING INSTRUCTIONS .....	2-21	<b>Compact Disc Section(UDCM-M7)</b>	
<b>Receiver Section(UDRA-M7)</b>		DISASSEMBLY .....	51, 52
DISASSEMBLY .....	22, 23	BLOCK DIAGRAM .....	53
BLOCK DIAGRAM .....	24	SEMICONDUCTORS .....	54-57
BLOCK LEVEL DIAGRAM .....	25	MICROPROCESSOR .....	58, 59
ADJUSTMENT .....	26	PRINTED WIRING BOARD .....	60-63
SEMICONDUCTORS .....	27-33	NOTE FOR PARTS LIST .....	64
MICROPROCESSOR .....	34-35	PARTS LIST OF P.W.B. UNIT ASS'Y .....	64-67
PRINTED WIRING BOARD .....	36-39	WIRING DIAGRAM .....	68
NOTE FOR PARTS LIST .....	40	EXPLODED VIEW .....	69, 70
PARTS LIST OF P.W.B. UNIT ASS'Y .....	40-44	PARTS LIST OF EXPLODED VIEW .....	71
WIRING DIAGRAM .....	45	EXPLODED VIEW OF CD MECHANISM .....	72
EXPLODED VIEW .....	46, 47	PARTS LIST OF CD MECHANISM .....	73
PARTS LIST OF EXPLODED VIEW .....	48	SCHEMATIC DIAGRAM .....	75,76
SCHEMATIC DIAGRAM .....	49, 50		

● Some illustrations using in this service manual are slightly different from the actual set.

## NIPPON COLUMBIA CO., LTD.

# GENERAL SECTION OPERATING INSTRUCTORS

### NOTE ON USE / HINWEISE ZUM GEBRAUCH OBSERVATIONS RELATIVES A L'UTILISATION / NOTE SULL'USO

<p>• Read full instructions before fit or before use. Lesen Sie die gesamte Bedienungsanleitung vor dem Einbau oder vor dem Gebrauch. Lire attentivement toutes les instructions avant de monter ou d'utiliser l'appareil. Leggere attentamente tutte le istruzioni prima di installare o utilizzare l'appareil.</p>	<p>• Plug the power cord into the wall outlet. Stecken Sie das Netzkabel in eine Steckdose. Raccorder le cordon d'alimentation à une prise murale. Inserire il cavo di alimentazione nella presa murale.</p>	<p>• Do not let foreign objects in the slot. Keine fremden Gegenstände in die Gitteröffnungen stecken. Ne pas laisser des objets étrangers dans l'appareil. Evitare l'entrata di oggetti estranei in nessuno dei fori.</p>
<p>• Handle the power cord carefully. Behandeln Sie das Netzkabel vorsichtig. Manipulez le cordon d'alimentation avec précaution. Manipolare il cavo di alimentazione con cura.</p>	<p>• Unplug the power cord when not using the set for long periods of time. Zieh das Netzkabel aus der Steckdose, wenn du das Gerät eine längere Zeit nicht verwenden wirst. Débranchez le cordon d'alimentation lorsque l'appareil n'est pas utilisé pendant de longues périodes. Disconnettere il cavo di alimentazione quando invece l'appareil non viene utilizzato per un lungo periodo di tempo.</p>	<p>• Do not use alcohol, benzene, and other solvents in contact with the set. Nicht mit dem Gerät mehr andere Flüssigkeiten, Benzin oder Verdünnungsmittel in Berührung bringen. Ne pas mettre en contact des alcools, du benzène ou d'autres solvants avec l'appareil. Assicurarsi che l'unità non venga in contatto con alcoolici, benzina o solventi.</p>
<p>• Do not disassemble or modify the set in any way. Nicht auseinanderbauen oder das Gerät in irgendeiner Weise verändern. Ne pas démonter ou modifier l'appareil d'aucune manière. Non smontare né modificare l'unità in nessun modo.</p>	<p>• Do not open the ventilation holes. Die Belüftungsöffnungen dürfen nicht verstopft werden. Ne pas ouvrir les trous d'aération. Non coprire i fori di ventilazione.</p>	<p>• Do not use alcohol, benzene, and other solvents in contact with the set. Nicht mit dem Gerät mehr andere Flüssigkeiten, Benzin oder Verdünnungsmittel in Berührung bringen. Ne pas mettre en contact des alcools, du benzène ou d'autres solvants avec l'appareil. Assicurarsi che l'unità non venga in contatto con alcoolici, benzina o solventi.</p>

**CAUTION / VORSICHT / ATTENTION / AVVISIO**

If the system should smoke or produce strange smells, immediately set the power operation switch to the STANDBY position, unplug the power cord, and contact your store of purchase.

Sollte das Gerät Rauch produzieren oder eigenartige Gerüche, stellen Sie den Netzschalter sofort auf die Position STANDBY (Bereitschaft), ziehen Sie den Netzstecker heraus und kontaktieren Sie Ihren Händler.

Si de la fumée sort de la chaîne ou des odeurs bizarres, placer l'interrupteur de fonctionnement de l'alimentation immédiatement sur la position de veille (STANDBY), débrancher le cordon d'alimentation et contacter le distributeur.

Qualora il sistema dovesse produrre del fumo o degli odori strani, collocare immediatamente l'interruttore di stato di operatività a accesso nella posizione STANDBY, sminacciare il filo di alimentazione e rivolgersi al negozio dell'acquistatore.

**SAFETY IMPORTANT**

**WARNING:** TO PREVENT FIRE OR SHOCK HAZARD, DO NOT EXPOSE THIS APPLIANCE TO RAIN OR MOISTURE

**ATTENZIONE:** QUESTO APPARECCHIO È DOTATO DI DISPOSITIVO OTTICO CON RAGGIO LASER. L'USO IMPROPRIO DELL'APPARECCHIO PUÒ CAUSARE PERICOLOSE ESPOSIZIONI A RADIAZIONI!

"SERIAL NO.  
PLEASE RECORD UNIT SERIAL NUMBER ATTACHED TO THE REAR OF THE CABINET FOR FUTURE REFERENCE"

**INSTALLATION PRECAUTIONS**  
For heat dispersal, leave at least 10 cm of space between the top, back and sides of this unit and the wall or other components.

**PRECAUTIONS D'INSTALLATION**  
Afin de dissiper la chaleur, laissez un espace d'au moins 10 cm entre le haut, l'arrière les côtés de cet appareil et le mur ou un autre composant.

**VORBEREITUNGEN ZUR INSTALLATION**  
Lassen Sie zur Wärmeabfuhr mindestens 10 cm Raum zwischen der Oberseite, der Rückseite und den Seiten des Gerätes und der Wand oder anderen Komponenten.

**PRECAUZIONI RIGUARDANTI L'INSTALLAZIONE**  
Per consentire una buona dispersione del calore, lasciate uno spazio di almeno 10 cm tra la parte superiore, posteriore e laterali di quest'unità e la parete o gli altri componenti.

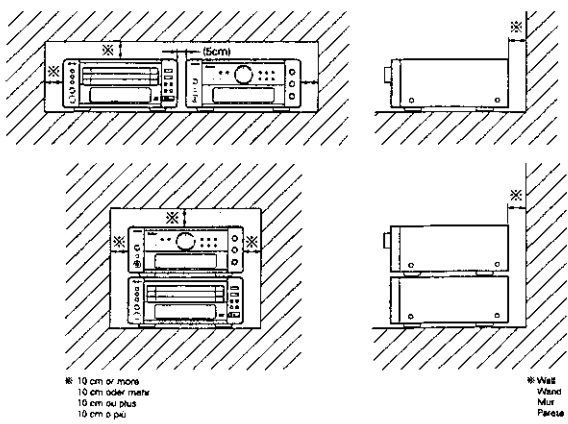

**CLASS 1 LASER PRODUCT**  
LIGNON 1 LASERLÄSSE  
KLASSE 1 LASERPRODUKT

**AVVARSSEL:** USTYMIŁY LASERSTRÄLNING VED ÅBNING, NÅR SÆKKEMÆTS/ÅBNERE ER LØSE AF FUNKTION. UDGÅ LØSÆTTET/LE FOR STRÅLING.

**VARNING:** LÄTTEN KÄTTÄNNEN MUULLA KUIN TÄSÄ. KÄYTTÖKÄYTTÄMÄN KÄYTTÖTAVALLA KÄYTTÄÄ KÄYTTÄMÄN TUUVALLUSKILJUNNAN I VUUTTAVALLA KÄYTTÄMÄLLÄ LASERSTRÄLLE.

**VARNING:** OMI APPARATIN ÅBNINGS PÅ ÅBNET SÅTT ÅR I DE NEVI BRUGSÅNVIJNINGER SPECIFIKERET, KAN ANVÆNDERN UTSÆTTES FØR OSYMLIG LASERSTRÅLING SOM ØVERSKRIDER GRÆNSER FØR LASERKLASSE 1



**TUNER-AMPLIFIER  
RADIO-VERSTÄRKER  
TUNER-AMPLIFICATEUR  
SINTONIZZATORE-AMPLIFICATORE  
SINTONIZADOR-AMPLIFICADOR  
TUNER-VERSTERKER  
RECEIVER  
SINTONIZADOR-AMPLIFICADOR**

See ENGLISH Page 6.  
Sehen Sie DEUTSCH Seite 24.  
Voir FRANÇAIS Page 42.  
Fate riferimento alla sezione ITALIANO alla pagina 60.  
Consulte la página 79 para ESPAÑOL.  
Zie NEDERLANDS bladzijde 97.  
Se SVENSKA sid 115.  
Veja em PORTUGUÊS página 133.

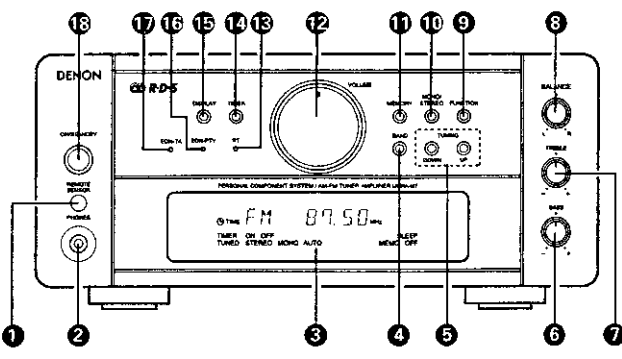

UDRA-M7

**CD AUTO CHANGER  
CD-AUTO-WECHSLER  
CHANGEUR CD AUTO  
CAMBIADISCI AUTOMATICO CD  
CAMBIADOR AUTOMÁTICO DE CD  
AUTOMATISCHE CD-WISSELAAR  
CD-VÄXLARE  
CARREGADOR AUTOMÁTICO DE CDs**

See ENGLISH Page 7.  
Sehen Sie DEUTSCH Seite 25.  
Voir FRANÇAIS Page 43.  
Fate riferimento alla sezione ITALIANO alla pagina 61.  
Consulte la página 80 para ESPAÑOL.  
Zie NEDERLANDS bladzijde 98.  
Se SVENSKA sid 116.  
Veja em PORTUGUÊS página 134.

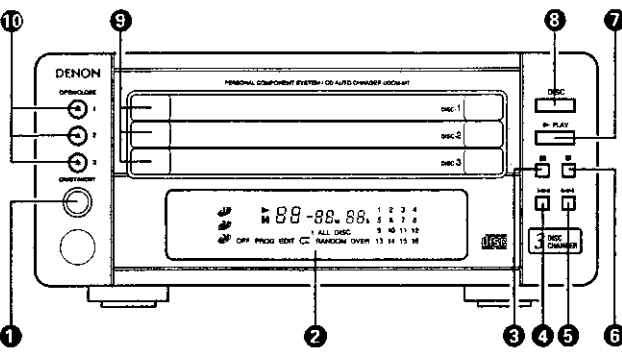

UDCM-M7

As an aid to better understanding the operation method, the illustrations used in this manual may differ from the actual system.

Als Hilfestellung zum besseren Verständnis der Betriebsmethode, erlauben wir uns den Hinweis, daß sich die Abbildungen in dieser Bedienungsanleitung leicht von dem aktuellen System unterscheiden.

Pour rendre la compréhension de la méthode de fonctionnement, les illustrations utilisées dans ce manuel peuvent être différentes de celles de la chaîne réelle.

Per rendere la comprensione del metodo operativo più facile, le illustrazioni usate in questo libretto delle istruzioni possono differire dal sistema stesso.

Como ayuda a un mejor entendimiento del método de funcionamiento, las ilustraciones utilizadas en este manual pueden diferir del sistema real.

Als bijkomend hulp om de bedieningsmethode beter te begrijpen, is het mogelijk dat de afbeeldingen die in deze handleiding zijn gebruikt verschillen van het eigenlijke systeem.

Illustrazioni / brugsanvisningen hjælper dig forstår de olika funktionerna. Studera dem nog. (Miss illustrationer kan ställa sig lite gram från din apparat.)

Como ajuda para uma melhor compreensão do método de funcionamento, as ilustrações utilizadas neste manual podem diferir do verdadeiro sistema.



CONTENTS

1 Main Features	4	3 Playing CDs	16 ~ 20
2 Before Using	4	• About Compact Discs	16
3 Connecting the Included Antennas	4	• Normal Playback	16, 17
4 Connections	5	• Various Playback Functions	17 ~ 19
5 Part Names, Functions and Displays	6 ~ 7	• Edited Recording on Side A and Side B of a Tape	19, 20
• Tuner-Amplifier	6	• Auto on Function	20
• CD Auto Changer	7	• Other Information	20
6 Remote Control Unit	8, 9	• Specifications	21
7 Listening to Radio Programs	10 ~ 12	• Troubleshooting	21
8 Using the Timer	13 ~ 15		

Check that the following parts are included in the package aside from the main unit:

- UDRA-M7 (Tuner-amplifier unit)
  - FM antenna
  - AM loop antenna
  - Remote control unit (RC-82B)
  - RSP/AA batteries
  - Operating instructions
- UDCM-M7 (CD auto changer unit)
  - System connector cable
  - RCA pin-plug cord

1 MAIN FEATURES

- **RDS receivable**  
Compatible with various RDS services, including program service name (PS), program type identification (PTY), traffic program identification (TP), clock time (CT), radio text message (RT) and enhanced other network (EON).
- **Quality power for high quality sound**  
30W + 30W (5 Ω) rms, DINI high quality amplifier and terminals for large speakers.
- **High sound quality, multi-function CD auto changer**  
Ech function for automatically erasing the tracks on a CD for recording onto sides A and B of a tape.

2 BEFORE USING

Read the following before using the system.

- **Before turning on the power**  
Check again that all connections are correct and that there are no problems with the connection cords. Be sure to unplug the power cord before connecting or disconnecting the connection cords.
- **Humming may be produced** if this system is set near a TV or other audio equipment. If this happens, try changing the position of the equipment or the connection cords.
- **Moving the system**  
Be sure to remove CDs before moving the system. If a CD is left in the CD auto changer, it may be scratched. When shipping, first specify the disc using the disc selector button, press the ON/STANDBY button to turn the off the "OFF" indicator, then unplug the power cord.

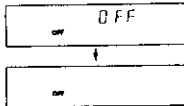

To prevent short-circuits or damage to the connection cords, always unplug the power cord and disconnect all connection cords to other audio equipment.

4

3 CONNECTING THE INCLUDED ANTENNAS

Installing the FM indoor antenna

Tune in an FM station (see Page 10), set the antenna in a position in which distortion and noise is minimum, then fasten the tip of the antenna in this position using tape or a pin.

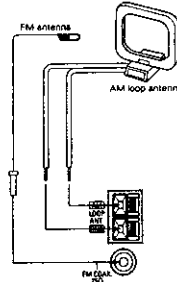

Connecting an FM outdoor antenna

If good reception cannot be achieved with the included FM antenna, use an FM outdoor antenna. Connect an F-shaped connector to the coaxial cable and connect the antenna to the FM COAX (75 Ω) terminals.

Selecting a place for the FM outdoor antenna

- Set the antenna so that it is pointing towards the broadcast station's transmitting antenna. (Behind buildings or mountains.)
- Set the antenna in the position at which reception is best, and also try changing the direction of the antenna.
- Do not install the antenna under power lines. Doing so is extremely dangerous, as the power line could touch the antenna.
- Install the antenna away from roads or train tracks to avoid noise from cars or trains.
- Do not install the antenna too high, as it may be hit by lightning.

Installing the AM loop antenna

Tune in an AM station (see Page 10) and set the antenna in a position as far from the system as possible in which distortion and noise is minimum. In some cases it is best to invert the poles. AM broadcasts cannot be received well if the loop antenna is not connected or if it is set close to metal objects.

Assembling the AM loop antenna

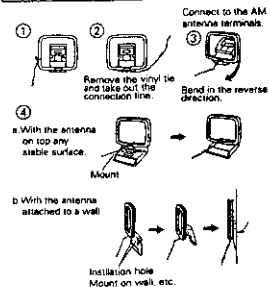

Installing an AM outdoor antenna

Connect the signal wires from the AM outdoor antenna to the antenna terminal. Be sure to ground the antenna and connect the ground wire to the GND terminal. Also be sure to connect the included AM loop antenna.

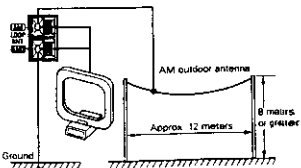

4 CONNECTIONS

**NOTE:**  
This system includes digital circuitry which may cause interference such as color blotching or changes in the color on TVs. If this happens, move the system and the TV as far apart as possible.

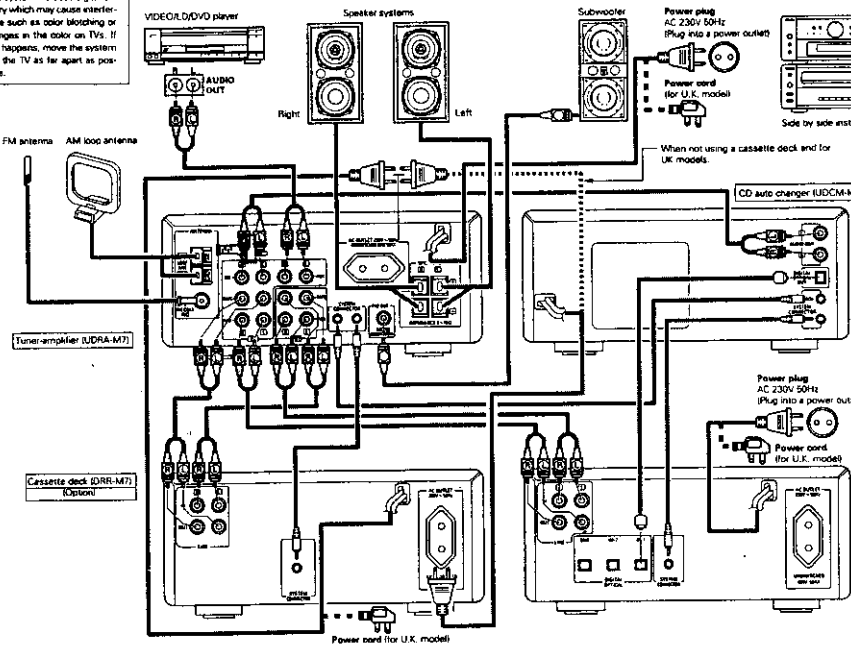

**Connecting the speaker systems**  
Connect the speaker system for the left channel (the left side as seen from the front) to the "L" terminals, the speaker system for the right channel to the "R" terminals. Be sure to use speaker systems with an impedance of 8 Ω (ohms) or greater.

**CAUTION:**  
Whenever the power switch is in the STANDBY position, the unit is still connected on AC line voltage. Please be sure to unplug the cord when you leave home for, say, a vacation.

Side by side installation

Install the sets as shown in one of these diagrams. In either case, be sure that the tuner-amplifier's ventilation holes are not obstructed.

Stacking installation

For U.K. models, only UDCM-M7 has 2-pin plug tether unit. 3-pin plug. So only UDCM-M7 can plug into the AC outlet on UDRA-M7.

System operations

System operations, such as the timer and the auto on functions, as well as remote control operations cannot be performed unless all the RCA pin-plug cords and system connector cords are connected between the units, so be sure to make all the connections properly as shown in the diagram. Also, disconnecting system connectors while the system is operating may result in malfunction. Be sure to turn unplug the power cord before changing connections.

- NOTES:**
- Do not plug the power cord into the power outlet until all connections are completed. Be sure to interconnect the channels (L to L (white) and R to R (red)) properly, as shown on the diagram.
  - Insert the plugs securely. Incomplete connections may result in noise.
  - Be sure to connect the speaker cords between the speaker terminals and the speaker systems with the same polarities (+ to +, - to -). If the polarities are switched, the sound at the center will be weak, the position of the different instruments will be unclear, and the stereo effect will be lost.
  - After unplugging the power cord, wait about 5 seconds before plugging it back in.
  - Note that setting the connection cords (pin-plug cords) next to the power cords may result in humming or other noise.
  - The total power consumption of equipment connected to the AC outlets is 80 W. Only use the outlets for D-M7 series components.

5

GENERAL SECTION

5 PART NAMES, FUNCTIONS AND DISPLAYS

TUNER-AMPLIFIER

- 1 **REMOTE SENSOR**  
When operating the remote control unit, point it at this sensor.
- 2 **PHONES (headphones) jack**  
Plug the headphones into this jack. No sound is produced from the speakers when headphones are plugged in.
- 3 **Display**
- 4 **BAND (AM/FM) selector button**  
The band switches between AM and FM each time this button is pressed.
- 5 **TUNING UP AND DOWN buttons**  
These buttons are used to select AM and FM stations and to set the clock and timer.
- 6 **BASS control**  
Use this to adjust the volume of the low frequencies.
- 7 **TREBLE control**  
Use this to adjust the volume of the high frequencies.
- 8 **BALANCE control**  
Use this to adjust the balance of the volume between the left and right channels. When set at the center position, the volume is the same for the left and right channels.
- 9 **FUNCTION (input) selector button**  
Use this to select the input function.  
The input changes in the following order each time this button is pressed: CD, TAPE, TUNER, MD and AUX. (The function changes automatically when the system's CD player or cassette deck is played or when a preset channel is recalled on the tuner.)
- 10 **MONO / STEREO selector button**  
**AUTO mode:**  
Use the mode to receive programs in stereo.  
The sound and the indicators on the display automatically switch between monaural ("MONO") and stereo ("STEREO") according to whether the programs being broadcast in monaural or stereo.  
**MONO mode:**  
Use this mode to receive programs in monaural, regardless of whether they are being broadcast in monaural or stereo.  
Set this mode if there is much noise or if the signals are weak when receiving stereo programs (when "AUTO" is set).
- 11 **MEMORY button**  
This button is used to preset AM and FM stations and when setting the timer.
- 12 **VOLUME control**  
Use this to adjust the overall volume.  
The volume increases when the control is turned clockwise (↻) and decreases when it is turned counter-clockwise (↺).
- 13 **RT Indicator**  
This lights in green when a radio station offering an RT service is tuned in.  
The indicator lights in red when the RT mode is selected. When the RT message is displayed, the indicator flashes in green.
- 14 **TIMER button**  
Press this when setting the timer and to turn the timer on so that it operates at the set times.  
When the button is pressed after the timer has been set, the timer standby mark (⏸) appears on the display. Press again to turn the mark off.  
The timer will not operate when the "⏸" mark is off.
- 15 **DISPLAY selector button**  
This button is used to switch the display between the reception frequency function and the clock.
- 16 **EON-PTY Indicator**  
This lights in green when an EON station with PTY information is being received.  
When the EON PTY mode is selected, the indicator lights in red.  
The indicator flashes in green when another broadcast station in the same network is automatically tuned in and a broadcast of the desired program type is being received.
- 17 **EON-TA Indicator**  
This lights in green when an EON station with traffic announcements is being received.  
When the EON TA mode is selected, the indicator lights in red.  
The indicator flashes in green when another broadcast station in the same network is automatically tuned in and a traffic announcement is being received.
- 18 **Power operation switch (ON / STANDBY)**  
This turns the power for the entire system on and off. Press this once to turn the power on, then press again to set the power to the standby mode.

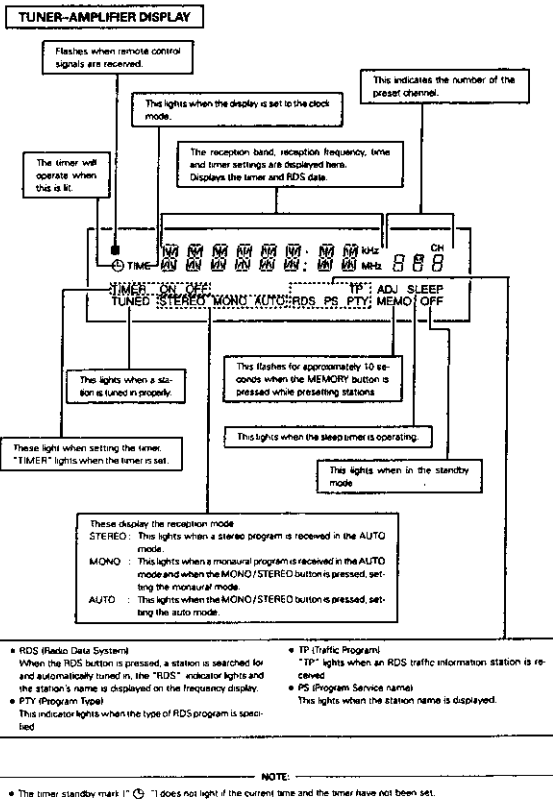

6

CD AUTO CHANGER

- 1 **Power operation switch (ON / STANDBY) button**  
Press this once to turn the CD auto changer's power on, then press again to set the CD auto changer to the standby mode. In the standby mode, "OFF" appears on the display.
- 2 **Display**
- 3 **⏸ (pause) button**  
Press this button to stop playback temporarily. Press the play button to cancel the pause mode and resume playback.
- 4 **⏮ (automatic search reverse) button**  
Use this to move to the beginning of a specific track. When pressed during playback or in the pause mode, the pickup moves backward a number of tracks equal to the number of times the button is pressed.
- 5 **⏭ (automatic search forward) button**  
Use this to move to the beginning of a specific track. When pressed during playback or in the pause mode, the pickup moves forward a number of tracks equal to the number of times the button is pressed.
- 6 **⏹ (stop) button**  
Press the button to stop playback.
- 7 **▶ (PLAY) button**  
Press this button to start playing the disc.  
Even when the disc tray is open, the disc tray closes and playback begins when this button is pressed.  
When pressed in the standby mode, the power automatically turns on and playback begins. (Auto on function)
- 8 **DISC button**  
Press this button to select the disc number. The Disc No. indicator changes each time the button is pressed. The disc whose indicator changes each time the button is pressed. The disc whose indicator is lit can be played.
- 9 **Disc tray**  
Load discs here.
- 10 **OPEN / CLOSE button**  
Press this to open and close the disc tray.  
When pressed once, the disc tray opens out, and when pressed again, the disc tray closes. If a disc is loaded, the total number of tracks and total playing time of the disc are displayed several seconds after the disc tray is closed. When pressed in the standby mode, the CD auto changer's power turns on.

CD AUTO CHANGER DISPLAY

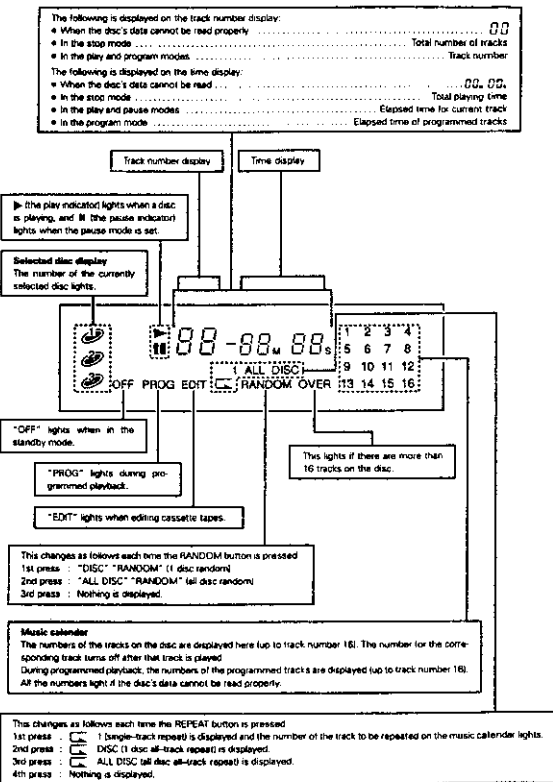

7

6 REMOTE CONTROL UNIT

The D-M7 comes with a system remote control unit (RC-828).

Inserting the batteries

NOTES:

- Use R6P (AA) batteries in the remote control unit.
- Replace the batteries with new ones approximately once each year, though this depends on how frequently the remote control unit is used.
- Replace the batteries with new ones earlier if the remote control unit does not operate even from a short distance.
- Insert the batteries in the proper + and - direction, following the marks in the battery compartment.
- Remove the batteries when not using the remote control unit for extended periods of time.
- To avoid damage and leakage:
  - Do not use a new battery with an old one.
  - Do not use two different types of batteries.
  - Do not short-circuit, take apart, heat or dispose of batteries in flames.
- If the batteries should leak, carefully wipe the fluid out of the battery compartment, then insert new batteries.

① Open the battery compartment cover on the back of the remote control unit. Press the knob and open the cover in the direction of the arrow.



② Insert the two R6P (AA) batteries, following the + and - marks in the battery compartment.

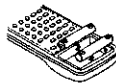

③ Close the cover of the battery compartment.

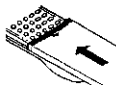

Using the Remote Control Unit

Cautions on Use

- The remote control unit may not operate if the remote sensor is exposed to direct sunlight or the strong light from a lighting fixture, or if there is an obstacle between the remote control unit and the remote sensor.
- Do not press buttons on the remote control unit and on the set at the same time. Doing so could result in malfunction.
- If the remote control unit is pointed away from the remote sensor during continuous operations such as when turning the volume up or down, the operation will stop. If this happens, point the remote control unit at the remote sensor and press the button again.

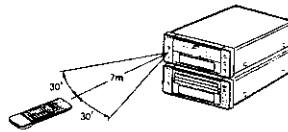

The remote sensor is located on the pre-main amplifier. Point the remote control unit at the remote sensor as shown on the diagram when operating it. The remote control unit will operate from a direct distance of approximately 7 meters, but this distance will be shortened if obstacles are present or if operated at an angle. (The remote control unit will operate at an angle of up to 30° in either direction.)

8

Remote Control Unit Part Names and Functions

**CD operation buttons**

- STOP button**: Press this button to stop playback.
- PLAY button**: Press this button to start playback.
- FF and RR (Automatic search buttons)**: Use these buttons to search for the beginning of the desired track.

**FUNCTION selector button**

Press this button to switch the input function. The input changes in the following order each time this button is pressed:

CD → TAPE → TUNER → MD → AUX

**TUNER button**

Press this button to recall preset stations from the remote control unit using the number buttons.

**Number buttons**

Press these buttons after pressing the TUNER button to recall preset stations. When playing a CD, press these buttons after pressing the DIRECT or PROGRAM button to specify the desired track.

**SDB (Super Dynamic Bass) button**

Press this for a sound with more powerful base.

**SLEEP button**

Press this button to set the sleep timer.

**RDS buttons**

Use this button to automatically tune to stations using the radio data system.

OFF → RDS → PTY → TP

**PTY button**

Press this button after selecting "PTY" with the RDS button to select one of the 15 program types.

**CT button**

Use this to connect the time of the clock on the UDRA-M7. Press this button when the time service of an RDS station is being properly received. "CT" and "TIME" are displayed for 2 seconds and the UDRA-M7's clock is corrected. "NO CT" is displayed if the RDS station does not offer a time service and when the broadcast is not being received properly.

**PANEL button**

This button is used to select the panel mode. Press this button when receiving RDS stations to select the frequency, PS, PTY or RT display. The display mode changes as follows each time the button is pressed:

PS → PTY → Frequency → RT

Note that this button will not function if the reception is poor.

OFF → EON TA → EON PTY → EON TA

**EON button**

Press this button to turn EON mode on and off. The mode changes as follows each time the button is pressed.

**Casette deck operation buttons**

- STOP button**: Press this button to stop the tape.
- Forward play button**: Press this to start playback or recording in the forward direction.
- Reverse play button**: Press this to start playback or recording in the reverse direction.

**POWER operation switch**

Use the switch to turn on the power of the entire system or set the power to the standby mode.

**PRESET buttons**

Use these buttons to recall preset stations on the tuner.

**VOLUME buttons**

Use these to adjust the volume. The volume increases when the ▲ button is pressed and decreases when the ▼ button is pressed.

**D. SKIP button**

Press this button to select the disc number. The DISC NO. indicator changes each time the button is pressed. The disc whose indicator is lit can be played.

**MD recorder buttons**

- REC (Recording) button**: Press this button to start recording.
- FF (Fast-forward) button**: Press this button to fast-forward the top side of the tape. (The bottom side of the tape is fast-forwarded.) Also use this button to search for the beginning of the current selection when playing in the forward (▶) direction, or to search for the beginning of the following selection when playing in the reverse (◀) direction.
- RR (Fast-reverse) button**: Press this button to fast-reverse the top side of the tape. (The bottom side of the tape is reversed.) Also use this button to search for the beginning of the current selection when playing in the forward (▶) direction, or to search for the beginning of the following selection when playing in the reverse (◀) direction.

**CASSETTE DECK operation buttons**

- REC / REC MUTE button**: To start recording from the stop mode, press this button, then press FF.
- FF button**: When this button is pressed during the recording, a blank section of approximately 5 seconds is created after which the recording standby mode is set.
- RR button**: Press this button to rewind and the top side of the tape. (The bottom side of the tape is fast-forwarded.) Also use this button to search for the beginning of the current selection when playing in the forward (▶) direction, or to search for the beginning of the following selection when playing in the reverse (◀) direction.
- FF button**: Press this button to fast-forward the top side of the tape. (The bottom side of the tape is reversed.) Also use this button to search for the beginning of the current selection when playing in the forward (▶) direction, or to search for the beginning of the following selection when playing in the reverse (◀) direction.

**CD auto changer operation buttons**

- DIRECT button**: Press this button for direct search on the CD auto changer.
- FF and RR (Manual search) buttons**: Press these buttons during playback to move quickly forward or backward.
- REPEAT button**: Press this button for repeat playback.
- RANDOM button**: Press this button to play the tracks in random order.
- PROGRAM button**: Press this button for programmed playback on the CD auto changer.
- CANCEL button**: Press this button to clear the last track from the program.
- EDT button**: Press this button for edited recording on a tape, dividing the tracks into sides A and B according to the length of the tape.
- TIME button**:
  - TIME**: Press this button during the play or pause mode to switch the time display. Normally, the elapsed time for the track currently playing is displayed. When this button is pressed, the display switches to the remaining time for the track:
    - total elapsed time on the disc
    - total remaining time on the disc
    - then back to the elapsed time per track
  - During programmed playback, the total remaining time display indicates the total remaining time of the programmed tracks.

**GENERAL SECTION**

**7 LISTENING TO RADIO PROGRAMS**

(Check the connections on Pages 5 and 6.)

**TUNING**

Tuner-Amplifier (UDA-417)

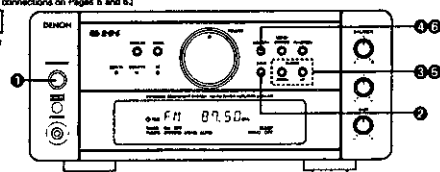

Example: Tuning in FM 87.50 MHz (AM stations are tuned in using the same procedure.)

1	Set the VOLUME control on the tuner-amplifier to the minimum position, then press the POWER operation switch to turn on the power.		
2	Press the BAND button on the tuner to select the FM band.		
3	Use the TUNING UP and DOWN buttons to tune the frequency to 87.50. Once the frequency is tuned in, adjust the volume to the desired level using the VOLUME control.		

**Auto Tuning**

- When one of the TUNING buttons is pressed, the frequency changes in steps of 50kHz in the FM band, 8kHz in the AM band.
- If one of the TUNING buttons is held in for over 1 second, the frequency continues to change when the button is released (auto tuning) and stops when a station is tuned in. Tuning will not stop at stations whose reception is poor.
- To stop the auto tuning function, press the UP or DOWN button once.

**Presetting AM and FM Stations**

Example: Presetting FM 87.50 (currently tuned in) at preset number 3

4	Press the MEMORY button. The <b>MEMO</b> indicator flashes for 10 seconds.		
5	Use the UP and DOWN buttons to call out the number at which you want to preset the station, or simply press the corresponding number button on the remote control unit.		
6	Press the MEMORY button while the <b>MEMO</b> indicator is flashing.		

**NOTES:**

- In addition to the reception frequency, the reception mode (mono/stereo) and auto preset, so check the display when presetting stations.
- If a station is preset at a number where a station is already preset, the previous station is replaced with the new station.
- The preset memory is not cleared when the power cord is unplugged.

10

**Listening to Preset Stations**

The preset stations can be recalled using the number buttons on the remote control unit. Also, if the following operation is performed when the system power is off, the power automatically turns on and the radio is played. (Auto on function)

Example: Listening to the station preset at number 3 (This operation is only possible from the remote control unit.)

1	Press the TUNER button on the remote control unit.		
2	Press button "3" on the remote control unit.		

**Using the RDS functions**

Receiving RDS broadcasts (FM only)

1	Press the BAND button and set the FM band.		
2	Press the RDS button once.		
3	Press the AUTO TUNING UP (▲) or DOWN (▼) button.		
4	The station is tuned in.		

NOTE: If no RDS station is found, "NO PROG" is displayed.

**PTY Search**

1	Press the RDS button twice.		
2	Press the PTY button to select the type of program. (One of the 15 types listed below can be selected.)		
3	Press the AUTO TUNING UP (▲) or DOWN (▼) button.		
4	The station is tuned in.		

NOTE: If no program of the specified type is found, "NO PROG" is displayed.

**TP Search**

1	Press the RDS button 3 times.		
2	Press the UP (▲) or DOWN (▼) button of AUTO TUNING.		
3	The station is tuned in.		

NOTE: "NO PROG" is displayed when there is no traffic information broadcast station.

**Receiving FM programs in stereo**

- Press the MONO/STEREO selector button to turn on the "AUTO" indicator. When a program being broadcast in stereo is received, the "STEREO" indicator lights and the program is received in stereo.
- If reception is poor and there is much noise in the stereo signal, press the MONO/STEREO selector button to set the monoaural mode.

**NOTE:**

A humming sound may be heard when using a TV nearby while receiving AM programs. If this happens, move the system as far from the TV as possible.

**Programs**

NEWS	(News)	VARIETY	(Variety)
AFFAIRS	(Current Affairs)	POP M	(Pop Music)
INFO	(Information)	ROCK M	(Rock Music)
SPORT	(Sport)	MOR M	(M.O.R. Music)
EDUCATE	(Education)	LIGHT M	(Light Classics)
DRAMA	(Drama)	CLASSICS	(Serious Classics)
CULTURE	(Culture)	OTHER M	(Other Music)
SCIENCE	(Science)		

11

GENERAL SECTION

Radio Text (RDS stations only)

1	When a radio station offering an RT service is tuned in, the RT indicator lights to indicate that the RT service can be received.		RT (Green)	FM 87.50
2	To turn the RT mode on, press the PANEL button on the remote control unit, until the RT indicator is lit in red. (Refer to page 9)		RT (Red)	HBR 3
3	When the station currently tuned in is offering a radio text message service, the message scrolls on the display. The RT indicator blinks in green.		RT (Green)	RADIO

- When the RT mode is turned on while an RDS radio station not offering an RT service is tuned in, "NO TEXT" flashes on the display, then the mode automatically switches to the PS mode when the RT service is finished. In this case, the mode automatically switches from the PS mode back to the RT mode when an RT broadcast is resumed.
- The RT mode cannot be set in the AM band or for FM stations not offering RDS broadcasts.
- To turn the RT mode off, press the PANEL button and switch to the desired display mode.

EON-TA (RDS stations only)

When an RDS station is broadcasting RDS information on other stations within the same network and a traffic announcement begins on another station in the same network based on this information (EON = Enhanced Other Network), that network station is automatically tuned in. The previous station is tuned back in once the traffic announcement is over.

1	When EON-TA function is not on while receiving EON-TA information, the EON-TA indicator lights in green.		EON-TA (Green)	HBR 3 (STATION A)
2	Press the EON button once, then the TA indicator turns on in red. (Refer to page 9)		EON-TA (Red)	STATION A
3	When a traffic announcement starts, that station is automatically tuned in. The EON-TA indicator blinks in green.		EON-TA (Green)	HBR 2 (STATION B)
4	When a traffic announcement is over, the previous station is tuned in. The EON-TA indicator stops blinking and remains lit in green. The EON-TA function turns off.		EON-TA (Green)	HBR 3 (STATION A)

- The EON-TA function cannot be turned on if the station currently tuned in is not an RDS station. If you attempt to do so, "NO RDS" flashes on the display.
- If the RDS station currently tuned in does not provide an EON service, the EON-TA function does turn on, but "NO EON" flashes on the display.
- To turn the EON-TA mode off, press the EON button until the EON-TA indicator turns off or lights in green, following the instructions on page 9. If the EON-TA mode is turned off under the conditions in 3 on the table above, Station B continues to be tuned in.
- If the tuning button, preset button, band button, system power button or function button is pressed when this mode is set, the mode is turned off.
- "NO TP" appears on the display if no traffic announcement is being broadcast on the network of the station which is currently tuned in.

EON-PTY (RDS stations only)

When an RDS station is broadcasting RDS information on other stations within the same network and a programme of the specified programme type (PTY) begins on a station in the same network, that network station is automatically tuned in. Use this function to tune in broadcasts of the desired programme type with priority.

1	When EON-PTY function is not on while receiving EON-PTY information, the EON-PTY indicator lights in green.		EON-PTY (Green)	HBR 3 (STATION A)
2	Press the EON button twice, then the EON-PTY indicator turns on in red. (Refer to page 9)		EON-PTY (Red)	SPORTS (STATION A)
3	The programme type flashes for approximately 5 seconds. During the time, press the PTY button to select the type of program. (Refer to page 11.)		EON-PTY (Red)	NEWS (STATION A)
4	Once the desired programme type is selected, set it with the MEMORY button.		EON-PTY (Red)	PDP H (STATION A)
5	When a programme of the specified programme type begins on a station in the same network, that station is tuned in. The EON-PTY indicator blinks in green.		EON-PTY (Green)	HBR 2 (STATION B)
6	The previous station is tuned back in once a programme of a different programme type begins. The EON-PTY indicator stops blinking, remaining lit in green. The EON-PTY function also turns off.		EON-PTY (Green)	HBR 3 (STATION A)

- The EON-PTY function cannot be turned on if the station currently tuned in is not an RDS station. If you attempt to do so, "NO RDS" flashes on the display.
- If the RDS station currently tuned in does not provide an EON service, the EON-PTY function does turn on, but "NO EON" flashes on the display.
- To turn the EON-PTY mode off, press the EON button until the EON-PTY indicator turns off or lights in green, following the instructions on page 9. If the EON-PTY mode is turned off under the conditions in 5 on the table above, Station B continues to be tuned in.
- If the tuning button, preset button, band button, system power button or function button is pressed when this mode is set, the mode is turned off.
- When using the EON-TA function together with the EON-PTY function, press the EON button once after making the settings on the above table. (Refer to page 9.)
- To reset the PTY after setting it, repeat the procedure from step 2.

NOTE:

- Be sure to turn the EON-TA and EON-PTY modes off when recording programmes.
- In the EON-TA and EON-PTY modes, if the station is switched from the current station to another station in the network but the signals of that network station are weak and cannot be tuned in properly, "WEAK" is displayed and the original station is immediately tuned back in.
- In the EON-TA mode, the station does not switch to another station in the network if the current station is broadcasting a traffic announcement.
- In the EON-PTY mode, the station does not switch to another station in the network if the current station is broadcasting a programme of the same programme type.
- Since the RDS services offered differ from station to station, some RDS functions may not operate for some stations, but this is a malfunction.

12

8 USING THE TIMER

The time and timer functions are incorporated in the tuner-amplifier.

Timer Settings

Types of timer operations

- TIMER**: Use this to turn the power on and off at the same times every day.
- SLEEP TIMER**: Use this to set the power to turn off after 10 to 90 minutes, in steps of 10 minutes (operated from the remote control unit).

Notes on timer settings

- Be sure to set the current time beforehand.
- To listen to or record a radio program ("air check") using the timer, be sure to preset the station beforehand. (Refer to "Presetting AM and FM Stations" on Page 11.)

Power Failures

Should there be a power failure or should the power cord be unplugged, the time display will flash. If this happens, reset the current time. Also check the timer and tuner presettings, and reset them if they have been cleared.

Checking the Settings

To check the timer settings, press the TIMER button for at least 4 seconds. (This can also be done when the tuner's power is off.) Next, press the MEMORY button repeatedly to display the timer start mode, the reception band and preset channel number when in the timer mode, the on time and the off time. Press the MEMORY button once more to return to the current mode display.

Changing the Settings

Repeat the timer setting operation to erase the previous settings and set the new settings.

Clearing the Settings

Press the TIMER button for at least 4 seconds, then press it for at least 4 seconds again while "FUNC" is displayed to clear the timer settings.

Note on Setting the Timer

If the time set with the timer is reached while the system power is on, the operation switches to the operation set by the timer.

Turning the Timer Off

Press the TIMER button to turn the mark off.

Setting the Current Time

The time is displayed in the 24-hour mode.

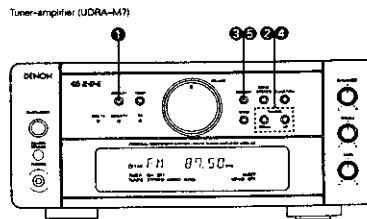

Example: Setting to 19:30 (7:30 p.m.)

1	Press the DISPLAY button for at least 4 seconds.		00:00	The hours place flashes (if the hours have already been set, both numbers flash.)
2	Use the UP and DOWN buttons to set the hours.		19:00	The hours place flashes
3	Press the MEMORY button.		19:00	The minutes place flashes (if the minutes have already been set, that number flashes.)
4	Use the UP and DOWN buttons to set the minutes.		19:30	The minutes place flashes
5	Press the MEMORY button at the sound of a time service's chime. The time display stops flashing and the clock starts running.		19:30	The display stops flashing and the clock starts running from 00 seconds

- The current time can be set even when the power is off.
- If an RDS station offers a time service, the time can be set by pressing the CT button on the remote control unit while that station is tuned in.

13

GENERAL SECTION

Setting the Timer

The power can be set to turn on and off every day at the same time in any of five modes: tuner, CD, cassette deck (optional), MD player (optional) and/or check recording from the radio. (Preset the AM or FM station beforehand.)

Tuner-amplifier (UDRA-M7)

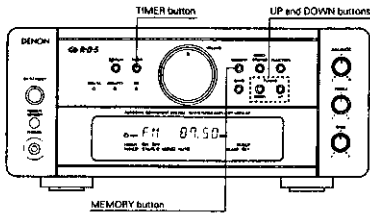

Example: Setting the tuner to turn on at 12:35, off at 12:56 (with FM 87.50 MHz preset at channel "3")

1	Press the POWER operation switch on the tuner-amplifier to turn on the system's power.		FM 90.00 P 7 Tuner
2	Press the TIMER button for at least 4 seconds to set the timer setting mode.		TIME FUNE
3	Use the UP and DOWN buttons to set the "TUNER" mode.		TIME TUNER
4	Press the MEMORY button.		Flashes TIME 87.50
5	Use the UP and DOWN buttons to set the preset channel number.		TIME 3
6	Press the MEMORY button.		Flashes TIME ON 12:00
7	Use the UP and DOWN buttons to set the hours for the timer on time.		TIME ON 12:35

14

8	Press the MEMORY button.		Flashes TIME ON 12:35 Flashes If the timer has already been set, that number flashes!
9	Use the UP and DOWN buttons to set the minutes for the timer on time.		Flashes TIME ON 12:56 Flashes
10	Press the MEMORY button.		Flashes TIME ON 12:00 Flashes
11	Use the UP and DOWN buttons to set the hours for the timer off time.		Flashes TIME OFF 12:00 Flashes
12	Press the MEMORY button.		Flashes TIME ON 12:35 Flashes If the timer has already been set, that number flashes!
13	Use the UP and DOWN buttons to set the minutes for the timer off time.		Flashes TIME OFF 12:56 Flashes If the timer has already been set, that number flashes!
14	Press the MEMORY button.		Flashes FM 90.00 P 7 The display returns to as it was before the timer setting mode was set.
15	Press the TIMER button.		Flashes TIME FM 90.00 P 7 Flashes
16	Press the POWER operation switch on the tuner-amplifier to turn off the system's power.		Flashes 10:15 PM Flashes

If the mark is displayed after the TIMER button is pressed, the timer will operate at the same times every day. To turn the timer off, press the TIMER button again to turn the mark off.

NOTE:

- The standby mark () will not light if the current time is not set. If this is the case, set the current time, then press the TIMER button.
- Be sure to set the power to the standby mode when using the timer.

Various Timer Operations

Tuner-amplifier (UDRA-M7)

CD auto changer (UDCM-M7)

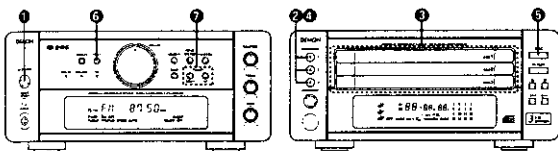

Example 1. Playing a compact disc with the timer

1	Press the POWER operation switch on the tuner-amplifier to turn on the system's power.		Flashes TIME ON 12:00 Flashes
2	Press the CD auto changer's OPEN/CLOSE button to open the disc tray.		Flashes TIME ON 12:00 Flashes
3	Load the disc in the disc tray. Refer to Page 16		
4	Press the CD auto changer's OPEN/CLOSE button again to close the disc tray.		Flashes TIME ON 12:00 Flashes
5	Press the DISC button to select the disc to be played.		Flashes TIME ON 12:00 Flashes
6	Press the tuner-amplifier's TIMER button for at least 4 seconds.		Flashes TIME FUNE Flashes
7	Use the tuner-amplifier's UP and DOWN buttons to set the "CD" mode.		Flashes TIME CD Flashes
8	Now follow steps 6 to 16 under "Setting the Timer" on Page 13.		

Setting the Sleep Timer

With this function, the power can be set to turn off after 10 to 60 minutes, in steps of 10 minutes, using the remote control unit.

Example: To turn the power off after 50 minutes when listening to FM 87.5 MHz (This operation is only possible from the remote control unit.)

1	Tuner currently set to FM 87.50 MHz		Flashes TIME FM 87.50 Flashes
2	Press the SLEEP button.		Flashes TIME 50 Flashes
3	Press the SLEEP button again while the "SLEEP" indicator is flashing.		Flashes TIME 50 Flashes
4	The previous display reappears after 5 seconds. The "SLEEP" indicator remains lit, indicating that the sleep timer is functioning.		Flashes TIME FM 87.50 Flashes

\* The time is reset to "60" (60 minutes) if the SLEEP button is pressed again while the sleep timer is functioning.

Canceling the Sleep Timer

Press the SLEEP button repeatedly until the "SLEEP" indicator turns off. The sleep timer is also cancelled if the tuner-amplifier's Power operation switch (ON/STANDBY) or the POWER switch on the remote control unit is pressed, turning the system power off.

NOTE:

\* If the times set with the sleep and everyday timers overlap, the sleep timer has priority.

Order of priority of the sleep and everyday timers

The sleep timer has priority for the off time. (The system operates as indicated by the bold lines.)

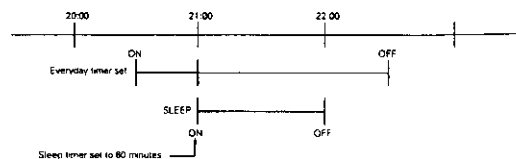

Even when the power was turned on with the timer, the power turns off if the remaining time of the sleep timer reaches "00" before the off time set with the everyday timer is reached. If the everyday timer's on time is reached while the sleep timer is functioning, the everyday timer does not function.

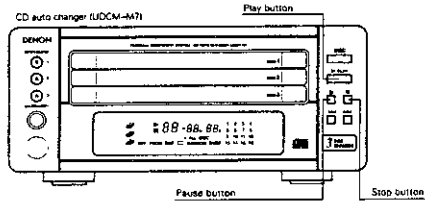

**Interrupting playback temporarily**

Press the **II** (pause) button.

The "II" mark appears on the display, and playback stops at the point where the button was pressed.

**Resuming playback**

Press the **▶** (PLAY) button.

The "II" mark turns off on the display, and playback resumes from the point where the pause button was pressed.

**Stopping playback**

Press the **■** (stop) button.

The display shows "00:00.00".

**NOTES:**

- When a disc is loaded, "00:00" is displayed on the display for several seconds while the data on the number of tracks and total playing time is being read from the innermost side of the disc, after which the number of tracks and total playing time appear.
- If no disc is loaded, if the disc is upside down, or if the data cannot be read properly due to scratches or dirt, the display reads as shown below and the disc will not play.

**Various Playback Functions**

In addition to the regular playback, the D-M7 also offers the following playback functions.

**① Playing a specific track** (Using the remote control unit) Example: Playing the 8th track

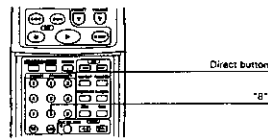

- Press the DIRECT button.
- Press the button corresponding to the number of the track. "8" appears on the track number display and playback of track number 8 begins.
- When the end of the track is reached, playback continues on the next track.
- To specify a track number of 11 or greater, say track 15, press **[10]** then **[5]**, and to specify a track number of 20 or greater, say track 23, press **[2 10]** then **[3]**. To play track 26, press **[2 10]** then **[10]**.

**② Playing a single track repeatedly** (Using the remote control unit)

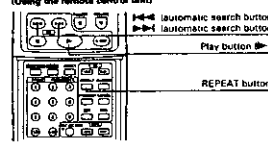

- When the REPEAT button is pressed once, "REPEAT" appears on the display and the single-track repeat mode is set.
- Use the **[◀]** and **[▶]** buttons to select the track to be repeated.
- Press the play button **[▶]** to start playback.
- When the end of the specified track is reached, playback starts over from the beginning of that track.
- The single-track repeat mode can also be set by pressing the REPEAT button once during playback.
- To cancel the single-track repeat mode, press the REPEAT button repeatedly until the "REPEAT" indicator turns off.

**③ Playing all the tracks repeatedly** (Using the remote control unit)

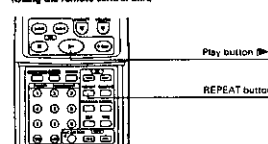

- When the REPEAT button is pressed twice, "ALL TRACK REPEAT" appears on the display and the all-track repeat mode is set.
- Press the play button **[▶]** to start playback.
- The all-track repeat mode can also be set by pressing the REPEAT button twice during playback.
- To cancel the all-track repeat mode, press the REPEAT button to turn the "ALL TRACK REPEAT" indicator off.
- If the REPEAT button is pressed during programmed playback, the tracks are played repeatedly in the programmed order.

**④ Playing all the disc repeatedly** (Using the remote control unit)

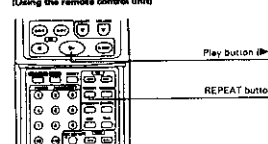

- When the REPEAT button is pressed, "ALL DISC REPEAT" appears on the display and the all-disc repeat mode is set.
- Press the play button **[▶]** to start playback.
- The all-disc repeat mode can also be set by pressing the REPEAT button 3 times during playback.
- To cancel the all-disc repeat mode, press the REPEAT button to turn the "ALL DISC REPEAT" indicator off.
- If the REPEAT button is pressed during programmed playback, the tracks are played repeatedly in the programmed order.

**8 PLAYING CDs**

**About Compact Discs**

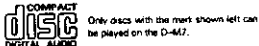

Use compact discs that include the **UDC** mark. CD's with special shapes (heart-shaped CDs, octagonal CDs etc.) cannot be played on this set. Attempting to do so may damage the set. Do not use such CDs.



For CDV's, only the audio part is played. (The video part is not played.)

**Removing discs from their cases**

As shown on the diagram, grasp the outer edge of the disc with your fingers, insert a finger in the center hole, press gently, then lift the disc out of the case.



**Loading discs in the disc tray**

Be sure to load the disc with the labeled side facing up. (Compact discs only play on one side.) For Bom CDs, set the disc in the sunken section in the center of the tray.

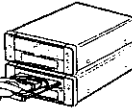

- NOTES:**
- The disc tray opens when the **OPEN/CLOSE** button is pressed once and closes when it is pressed again.
  - When the disc tray is closed, the disc turns automatically for several seconds, then the total number of tracks and total playing time of that disc appear on the display.
  - The disc tray can also be closed by pressing the **▶** (PLAY) button, in which case playback automatically starts from the first track on the disc for 8 tracks are programmed, from the first programmed track.

**Handling the Disc Tray**

Do not turn off the power, stop the disc tray by hand or put on it when it is moving. Doing so may damage it. If the headphones, cord or some other object accidentally gets caught in the disc tray while it is closing and the disc tray stops, press the **OPEN/CLOSE** button again to open the tray and remove the obstacle. Do not set objects other than discs on the disc tray. Doing so may damage it.

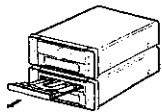

**Normal Playback**

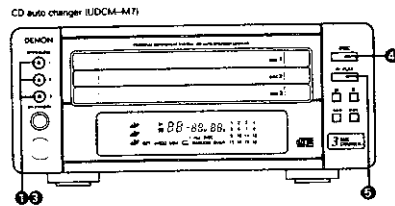

Example: Playing a disc containing 15 tracks and with a playing time of 62 minutes, 03 seconds, starting from the first track

The **[R]** mark indicates operations which can also be performed on the remote control unit

1	Press the <b>OPEN/CLOSE</b> button of the disc tray you want to open the disc tray.		OP ER
2	Load the CD in the disc tray.		
3	Press the <b>OPEN/CLOSE</b> button. The disc tray closes. The display appears after several seconds.		15 62.03. 1 2 3 4 5 6 7 8 9 10 11 12 13 14 15
4	Press the <b>DISC</b> button to select the disc to be played.		
5	Press the <b>▶</b> (PLAY) button.		01 00.04. 1 2 3 4 5 6 7 8 9 10 11 12 13 14 15





**GENERAL SECTION**

3	Press the <b>FUNCTION</b> button on the tuner-amplifier to set the CD mode.		
4	Press the <b>EDIT</b> button on the remote control unit to set the length of the tape. (The length is the total for sides A and B.) For a 60-minute (C-60) tape, press the <b>EDIT</b> button 2 times.  The display changes as shown below each time the <b>EDIT</b> button is pressed (if the tape length has already been set once, the display changes starting from that length.)    Inputting other tape sizes: To input other tape sizes, use the number buttons when "C---" is displayed.		Load the cassette tape onto which you want to record in the cassette deck with side A facing up.  Example: For a 60-minute tape   Side A display - Tracks 1 to 9 will be recorded on side A.  1 minute, 20 seconds remaining on side B  Side B display
5	After this, the remaining times for sides A and B are displayed alternately for several seconds each.		
6	Press the play button on the remote control unit or the CD auto-changer.		
7	The tape is automatically wound to the beginning on the cassette deck, then recording starts.		

• To set a time other than 45, 60 or 90, input the time when "C---" is displayed. The time can be set to up to 99 minutes. The time is input in the same way as when inputting track numbers for the CD direct search operation.

**10 AUTO ON FUNCTION**

- When the play button or OPEN/CLOSE button on the CD auto-changer, cassette deck (optional) or MD recorder (optional) is pressed while the power is set to the standby mode, the power automatically turns on and the play or open/close operation is performed.
- In the same way, when the tuner preset up/down buttons on the remote control unit is pressed, the power turns on and the corresponding station is tuned in.

**11 OTHER INFORMATION**

**Cleaning Discs**

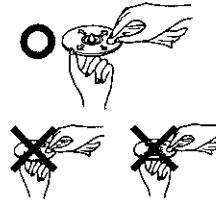

Dust, fingerprints or spit on the disc will result in noise or skipping. If the disc is dirty or if the CD auto-changer does not operate properly, use the following procedure to clean the disc:

- Hold the disc with the signal surface (the side opposite the labelled side) facing up, as shown in the diagram.
- Wipe the disc gently from the center towards the edge in the direction of the arrow with a soft cloth.

- Do not clean discs with the following:
- Solvents, alcohol or other solvents
  - Cleaners including an abrasive
  - Sprays or cleaners designed for records
  - Anti-static

**NOTES**

- Do not wipe discs in the direction opposite the arrow or in a circular motion as with regular records.
- The disc's signal surface is easily damaged. Do not wipe it with a hard cloth or rub it strongly.

20

**12 SPECIFICATIONS**

<b>■ Tuner-amplifier (UDRA-M7)</b>	FM: 87.50 MHz ~ 108.00 MHz
<b>Reception frequency band:</b>	AM: 522 kHz ~ 1611 kHz
<b>Reception sensitivity:</b>	FM: 1.5 μV/75 Ω/ohms
	AM: 20 μV
<b>FM stereo separation:</b>	35 dB (1 kHz)
<b>Rated output power:</b>	30 W ~ 30 W (8 Ω / ohms, DNH)
<b>Low frequency adjustment range:</b>	100 Hz ~ 8 dB
<b>High frequency adjustment range:</b>	10 kHz ~ 8 dB
<b>Audio input / output jacks:</b>	CD input jacks, tape in/output jacks, AUX, input jacks, MD input/output jacks, 3.5 mm headphones jack
<b>Power supply:</b>	AC 230 V, 50 Hz
<b>Power consumption:</b>	85 W
<b>Maximum external dimensions:</b>	210 (W) × 95 (H) × 323 (D) mm
	8-17/8" × 3-45/8" × 12-7/8" (including feet, controls and terminals)
<b>Weight:</b>	3.5 kg (7 lbs, 11 oz)
<b>■ CD auto-changer (UDCM-M7)</b>	
<b>Wow &amp; flutter:</b>	Below measurable limits (±0.001% W, peak)
<b>Sampling frequency:</b>	44.1 kHz
<b>Optical source:</b>	Semiconductor
<b>Power supply:</b>	AC 230 V, 50 Hz
<b>Power consumption:</b>	12 W
<b>Maximum external dimensions:</b>	210 (W) × 97 (H) × 343 (D) mm
	8-17/8" × 3-45/8" × 13-5/16" (including feet, controls and terminals)
<b>Weight:</b>	3.0 kg (6 lbs, 13 oz)
<b>■ Remote control unit (RC-428)</b>	
<b>Remote control system:</b>	Infrared pulse
<b>Number of buttons:</b>	47
<b>Power supply:</b>	Two DC 1.5V R6P/AA batteries
<b>Maximum external dimensions:</b>	67 (W) × 197 (H) × 21 (D) mm
	2-4 1/8" × 7-3/4" × 53/8"
<b>Weight:</b>	145 g (including batteries) (Approx. 4.6 oz)

\* Maximum dimensions include controls, jacks, and covers.  
(W) = width, (H) = height, (D) = depth  
• For improvement purposes, specifications and functions are subject to change without advanced notice.

**13 TROUBLESHOOTING**

Check the following once more before assuming there is a problem with the system.

1. Are connections proper?
2. Is the system being operated as explained in the operating instructions?

If the system does not seem to be operating properly, check as shown on the table below. If none of these checks apply to the problem, the system may be malfunctioning. Disconnect the power cord immediately and contact your store of purchase.

	Symptom	Cause	Countermeasure	Page
General	Power does not turn on when power operation switch is pressed.	• Power cord is not plugged into a power outlet.	• Plug the power cord securely into an outlet.	5
	No sound is produced from the speakers.	• VOLUME control is turned down. • Headphones are connected. • Speaker cords are not securely connected.	• Set the control to an appropriate position. • Disconnect the headphones. • Connect securely.	6 6 6
	No treble sound is produced, or the position of the instruments is unclear.	• Speaker polarities (⊕ and ⊖) are inverted.	• Connect the speaker cords properly.	5
Tuner	A source other than the designated one is heard.	• Function is not properly set.	• Set the desired function using the FUNCTION button.	6
	Hissing sound is heard in FM programs.	• Antenna direction is poor. • Signals from the broadcast station are weak.	• Change the direction of the antenna. • Install an outdoor antenna.	4 4
	Hissing sound is heard in AM programs.	• Noise from a TV or interference from a broadcast station.	• Turn the TV off. • Change the direction of the loop antenna. • Install an outdoor antenna.	- 4 4
	Humming sound is heard in AM programs.	• Signals on the power cord are being modulated by the power source frequency.	• Insert the power cord in the opposite direction. • Install an outdoor antenna.	- 4
CD Player	Total number of tracks not displayed when disc is loaded.	• Disc is loaded upside-down. • Disc is dirty. • Disc is not of the specified type.	• Reload the disc. • Clean the disc. • Replace with a disc of the specified type.	16 20 -
	Nothing happens when operating buttons are pressed. Disc stops in the middle of a track and will not play properly.	• Disc is loaded upside-down. • Foreign object on disc tray. • Disc is dirty. • Disc is scratched.	• Reload the disc. • Remove the disc and the foreign object. • Clean the disc. • Replace with an unscratched disc.	16 16 20 -
	Sound is broken.	• Dirt, fingerprints, spittle, etc. on disc. • Disc is scratched. • Player is in an unstable place and vibrates strongly.	• Clean the disc. • Replace with an unscratched disc. • Place the player in a stable place with no vibrations.	20 - -
	Humming sound is heard when disc is played.	• Signals on the power cord are being modulated by the power source frequency.	• Insert the power cord in the opposite direction.	-

**• Protector circuit**







The UDRA-M7 is equipped with a high speed protector circuit. This circuit protects internal parts from being damaged by strong currents generated in the set should the set be operated when the speaker terminals are incompletely connected or short-circuited. If this protector circuit is activated, a relay sound is produced, the output to the speakers is interrupted, and the function and power LEDs flash to indicate that there is a problem. If this should happen, unplug the power cord, check the speaker connections, then plug in the power cord and turn the power back on. After several seconds, a relay sound is heard and the set starts operating properly.

- The set may not operate properly due to such external influences as lightning or static electricity. If this happens, either turn off the power with the tuner-amplifier's POWER operation switch or unplug the power cord, wait approximately 5 seconds, then plug the power cord back in.

GENERAL SECTION

OPERATING INSTRUCTORS [For Asia model]

NOTE ON USE / 使用注意事項

 <p>• Avoid high temperature. Allow for sufficient heat dispersion when installed on a rack. <b>防止高溫</b> • 將本機裝於通風良好處並注意周圍的散熱。 <b>避免/裝置安裝注意</b> • 請勿將本機裝於狹窄的機架內。 • 切勿將本機裝於熱線、暖氣管或熱線的通道內。這會導致過熱。</p>	 <p>• Keep the set free from moisture, water, and dust. <b>注意濕氣、水和塵</b> • 勿將本機裝於潮濕或有多量水份的地方。尤應避免其它水分的物件與本機接觸。 <b>實例外出現</b> • 長時間不用本機時，請將本機取出機架，並將機架內濕氣清除。</p>	 <p>• Do not let foreign objects in the set. <b>勿讓雜物進入機內</b> • 勿將任何雜物放入機內。 <b>保護機體</b> • 避免在本機附近噴灑液體，包括用洗潔劑、水或任何其他清潔劑。勿用酒精或汽油清潔機體。請用乾布清潔機體。切勿將機體拆開或修改。</p>
 <p>• Handle the power cord carefully. Hold the plug when unplugging the cord. <b>留意電源線</b> • 取出電源線時，請握住插頭，不要拉扯電源線。 <b>勿堵塞通風孔</b> • 取出電源線時，請握住插頭，不要拉扯電源線。切勿堵塞通風孔。</p>	 <p>• For sets with ventilation holes: • 備有通風孔的機架 • Do not obstruct the ventilation holes. <b>勿堵塞通風孔</b> • 取出電源線時，請握住插頭，不要拉扯電源線。切勿堵塞通風孔。</p>	 <p>• Never disassemble or modify the set in any way. <b>勿拆解機體</b> • 切勿拆解機體或修改。請勿將機體拆開或修改。切勿將機體拆開或修改。切勿將機體拆開或修改。</p>

CAUTION/注意事項

- If the system should smoke or produce strange smells, immediately set the power operation switch to the STANDBY position, unplug the power cord, and contact your store or purveyor.
- 如果系統有煙霧或產生怪味，應立即將電源開關轉至STANDBY(待機)位，並下電線，再向購入的商號查詢。

SAFETY IMPORTANT/注意安全

WARNING: TO PREVENT FIRE OR SHOCK HAZARD, DO NOT EXPOSE THIS APPLIANCE TO RAIN OR MOISTURE.

警告：為避免火災或電擊意外，請勿讓設備受潮或淋水。

"SERIAL NO. / 編號  
PLEASE RECORD UNIT SERIAL NUMBER ATTACHED TO THE REAR OF THE CABINET FOR FUTURE REFERENCE"  
請記下機背背面附帶的機身編號供日後參考。"

INSTALLATION PRECAUTIONS

For heat dispersal, leave at least 10 cm of space between the top, back and sides of the unit and the wall or other components.

安裝注意事項

為散熱起見，務必在本機頂上、後方和內邊與鄰機之間留有空隙(10厘米)。

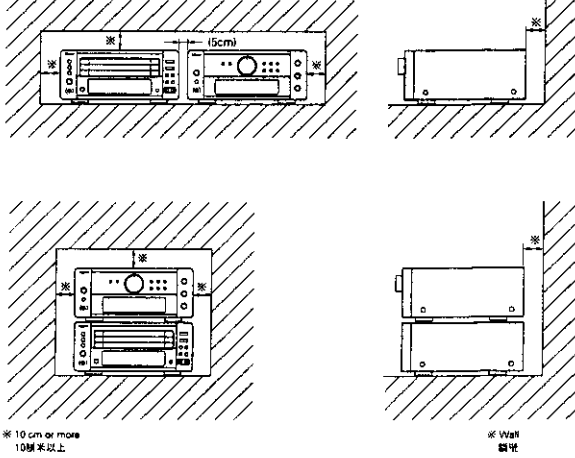

CLASS 1 LASER PRODUCT  
LUDEAN 1 LASERLAITE  
KLASS 1 LASERAPPARAT  
ADVARNEL: USYTLIG LASERSTRÅLING VED ÅBNING. NÅR BRUKER-REDEAFØRDELE ER LUKT AF FUNKTION. UNDGÅ UØSKJETTELSE FOR STRÅLING.  
VARNING: LÄTTEN RÄVTTÄMMAN MÖJLIG RIN TÄSSÄ KÄYTTÖOHJESSA SAUNTELLE TAVALLE SAATTAA ALISTAA KÄYTTÄJÄN TURVALLISUUDEN YLITTAVALLE NÄKYMÄTTÖMÄLLE LASERÄTTEYLLE.  
VARNING: OM APPARATEN ANVÄNDE PÅ ANNET SÄTT ÄN I DENNA BRUKANVVISNING SPECIFIKATS, KAN ANVÄNDAREN UTÄTTAS FÖR ÖSTYLIG LASERSTRÅLING SOM ÖVERSKRIDER GRÄNSEN FÖR LASERKLASS 1.



TUNER-AMPLIFIER  
調諧-擴音器

See ENGLISH Page 6.  
見第24頁

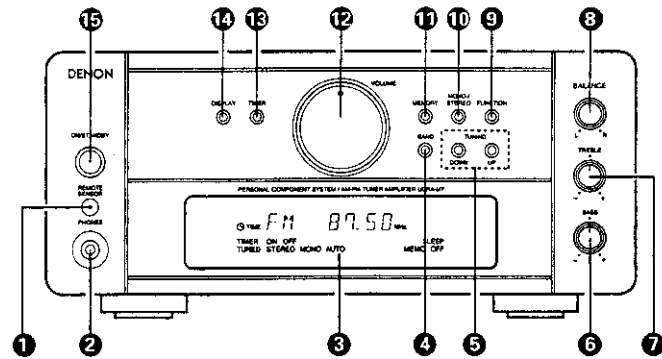

UDRA-M7

CD AUTO CHANGER  
光碟自動換碟器

See ENGLISH Page 7.  
見第25頁

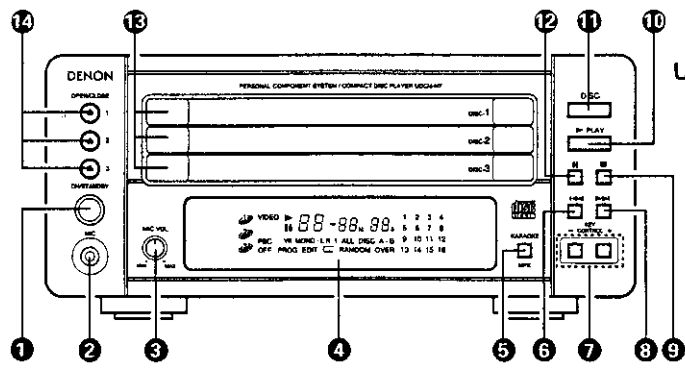

UDCM-M7

• As an aid to better understanding the operation method, the illustrations used in the manual may differ from actual system.  
• 本說明書內各插圖僅供協助理解操作方法用途，實際系統建設或會有別樣。

# GENERAL SECTION (For Asia model)

## CONTENTS

17	Main Features	4
2	Before Using	4
3	Connecting the Included Antennas	4
4	Connections	5
5	Part Names, Functions and Displays	6 ~ 7
6	Tuner-Amplifier	8
7	CD Auto Changer	7
8	Remote Control Unit	8, 9
9	Listening to Radio Programs	10
10	Using the Timer	11 ~ 13
11	Playing CDs	14 ~ 20
12	About Compact Discs	14
13	Normal Playback	15
14	Various Playback Functions	16 ~ 18
15	Edited Recording on Side A and Side B of a Tape	18
16	Playing Video CDs	19
17	Using the Karaoke Functions	20
18	Auto On Function	20
19	Other Information	20
20	Specifications	21
21	Troubleshooting	21

- Check that the following parts are included in the package aside from the main unit:
- UDCM-M7 (Tuner-amplifier unit)
    - FM antenna
    - AM loop antenna
    - Remote control unit (RC-831)
    - RSP/AA batteries
    - Operating instructions
  - UDCM-M7 (CD auto changer unit)
    - System connector cable
    - RCA pin-plug cord

## 1 MAIN FEATURES

- Quality power for high quality sound**  
30W + 30W 16 Ω ohms, DNM high quality amplifier and terminals for large speakers.
- High sound quality, multi-function CD auto changer**  
Edit function for automatically dividing the tracks on a CD for recording onto sides A and B of a tape.

## 2 BEFORE USING

### Read the following before using the system.

- Before turning on the power**  
Check again that all connections are correct and that there are no problems with the connection cords. Be sure to unplug the power cord before connecting or disconnecting the connection cords.
- Humming may be produced** if the system is set near a TV or other audio equipment. If this happens, try changing the position of the equipment or the connection cords.
- Moving the system**  
Be sure to remove CDs before moving the system. If a CD is left in the CD auto changer, it may be scratched. When stopping first (specify the disc using the disc selector button, press the ON/STANDBY button to turn the off the "OFF" indicator, then unplug the power cord.

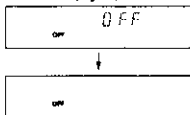

To prevent short-circuits or damage to the connection cords, always unplug the power cord and disconnect all connection cords to other audio equipment.

- Two types of timers**  
Two timer settings can be made — everyday and sleep.
- Easy-to-use remote control unit**
- Auto on function**  
The power turns on automatically and playback begins when the play button on the CD auto changer or the cassette deck or the tuner-amplifier press up/down buttons on the remote control unit are pressed.
- Condensation (dew)**  
Condensation (water droplets) may be produced on internal optical lenses or discs in the following cases:
  - Directly after a heater is turned on.
  - When the system is in a steamy or humid room.
  - When the system is moved abruptly from a cold place (room) to a warm room.
- Should condensation occur**  
The signals on the disc cannot be read and the system will not function properly. Remove the disc then let the system sit with the power on. The condensation will evaporate in one hour or less, at which time the system will function normally.
- Note** the some of the illustrations used for explanations in this manual may differ from the actual system.

## 3 CONNECTING THE INCLUDED ANTENNAS

### Installing the FM indoor antenna

Tune in an FM station (see Page 10), set the antenna in a position in which distortion and noise is minimum, then fasten the top of the antenna in this position using tape or a pin.

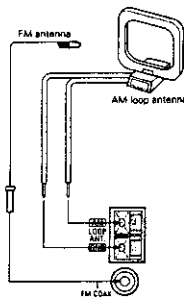

### Installing the AM loop antenna

Tune in an AM station (see Page 10) and set the antenna in a position as far from the system as possible in which distortion and noise is minimum. In some cases it is best to invert the polarities. AM broadcasts cannot be received well if the antenna is not connected or if it is set close to metal objects.

### Assembling the AM loop antenna

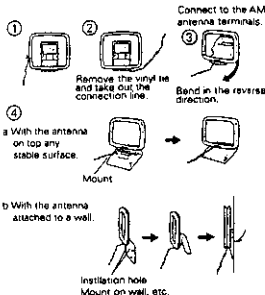

### Connecting an FM outdoor antenna

If good reception cannot be achieved with the included FM antenna, use an FM outdoor antenna. Connect an F-shaped connector to the coaxial cable and connect the antenna to the FM CGAX (75 Ω ohms) terminal.

### Selecting a place for the FM outdoor antenna

- Set the antenna so that it is pointing towards the broadcast station's transmitting antenna. Behind buildings or mountains, set the antenna in the position at which reception is best, and also try changing the direction of the antenna.
- Do not install the antenna under power lines. Doing so is extremely dangerous, as the power line could touch the antenna.
- Install the antenna away from roads or train tracks to avoid noise from cars or trains.
- Do not install the antenna too high, as it may be hit by lightning.

### Installing an AM outdoor antenna

Connect the signal wire from the AM outdoor antenna to the antenna terminal. Be sure to ground the antenna and connect the ground wire to the GND terminal. Also be sure to connect the included AM loop antenna.

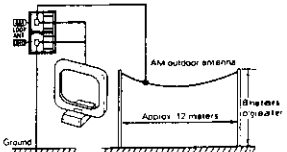

## 4 CONNECTIONS

**NOTE**  
This system includes digital circuitry which may cause interference such as color blotching or changes in the color on TVs. If this happens, move the system and the TV as far apart as possible.

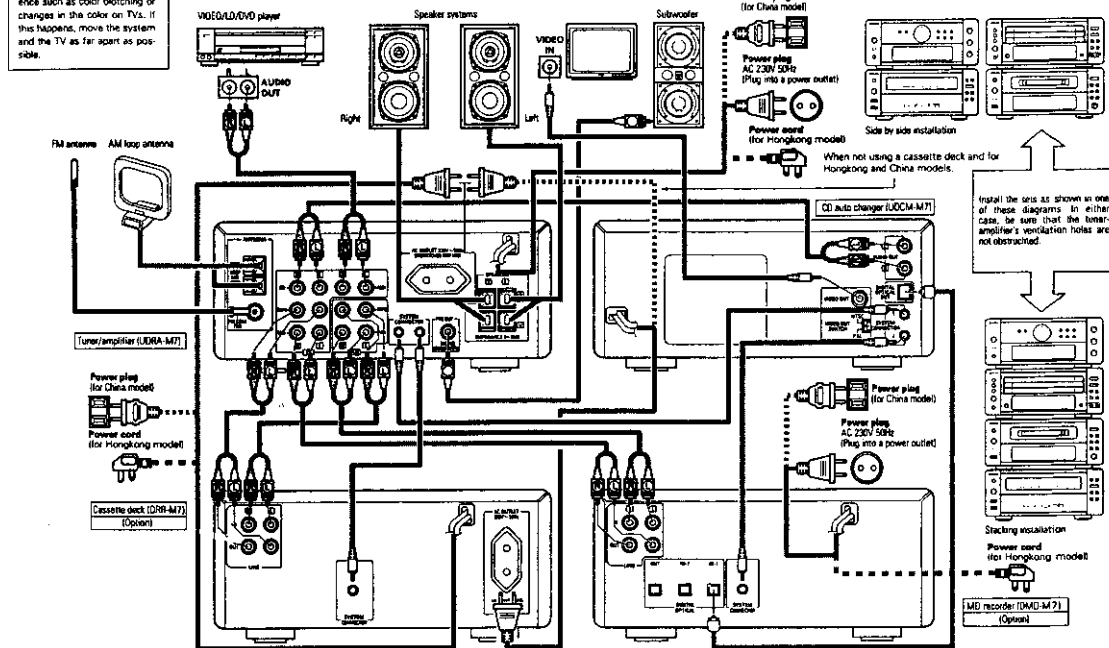

For Hongkong and China models, only UDCM-M7 has 2-pin plug (tuner unit, 3-pin plug). So only UDCM-M7 can plug into the AC outlet on UDRA-M7.

**System operations**  
System operations, such as the timer and the auto on functions, as well as remote control operations cannot be performed unless all the RCA pin-plug cords and system connector cords are connected between the units. So be sure to make all the connections properly as shown in the diagram. Also, disconnecting system connectors while the system is operating may result in malfunction. Be sure to turn unplug the power cord before changing connections.

- NOTES:**
- Do not plug the power cord into the power outlet until all connectors are completed. Be sure to interconnect the channels (L to L, white) and (R to R) reds properly, as shown on the diagram.
  - Insert the plugs securely. Incomplete connections may result in noise.
  - Be sure to connect the speaker cords between the speaker terminals and the speaker systems with the same polarities (+ to +, - to -). If the polarities are switched, the sound at the center will be weak. The position of the different instruments will be unclear, and the stereo effect will be lost.
  - After unplugging the power cord, wait about 5 seconds before plugging it back in.
  - Note that setting the connection cords (pin-plug cords) next to the power cords may result in humming or other noise.
  - The total power consumption of equipment connected to the AC outlets is 60 W. Only use the outlets for D-M7 series components.
  - The audio signals of a video CD cannot be recorded in digital.

**GENERAL SECTION**  
**[For Asia model]**

**5 PART NAMES, FUNCTIONS AND DISPLAYS**

**TUNER-AMPLIFIER**

- 1 REMOTE SENSOR**  
When operating the remote control unit, point it at this sensor.
- 2 PHONES (headphones jack)**  
Plug the headphones into this jack. No sound is produced from the speakers when headphones are plugged in.
- 3 Display**
- 4 BAND (AM / FM) selector button**  
The band switches between AM and FM each time this button is pressed.
- 5 TUNING UP and DOWN buttons**  
These buttons are used to select AM and FM stations and to set the clock and timer.
- 6 BASS control**  
Use this to adjust the volume of the low frequencies.
- 7 TREBLE control**  
Use this to adjust the volume of the high frequencies.
- 8 BALANCE control**  
Use this to adjust the balance of the volume between the left and right channels. When set at the center position, the volume is the same for the left and right channels.
- 9 FUNCTION (input selector) button**  
Use this to select the input (function). The input changes in the following order each time this button is pressed: CD, TAPE, TUNER, MD and AUX. (The function changes automatically when the system's CD auto changer or cassette deck is played or when a preset channel is recalled on the tuner-amplifier.)
- 10 MONO / STEREO selector button**  
**AUTO mode:**  
Use this mode to receive programs in stereo. The sound and the indicators on the display automatically switch between monaural ("MONO") and stereo ("STEREO") according to whether the program is being broadcast in monaural or stereo.  
**MONO mode:**  
Use this mode to receive programs in monaural, regardless of whether they are being broadcast in monaural or stereo. Set this mode if there is much noise or if the signals are weak when receiving stereo programs (when "AUTO" is set).

- 11 MEMORY button**  
This button is used to preset AM and FM stations and when setting the timer.
- 12 VOLUME control**  
Use this to adjust the overall volume. The volume increases when the control is turned clockwise (↻) and decreases when it is turned counter-clockwise (↺).
- 13 TIMER button**  
Press this when setting the timer and to turn the timer on so that it operates at the set times. When the button is pressed after the timer has been set, the timer standby mark (⏸) appears on the display. Press again to turn the mark off. The timer will not operate when the "⏸" mark is off.
- 14 DISPLAY selector button**  
This button is used to switch the display between the reception frequency (function) and the clock.
- 15 Power operation switch (ON / STANDBY)**  
This turns the power for the entire system on and off. Press the once to turn the power on, then press again to set the power to the standby mode.

**TUNER-AMPLIFIER DISPLAY**

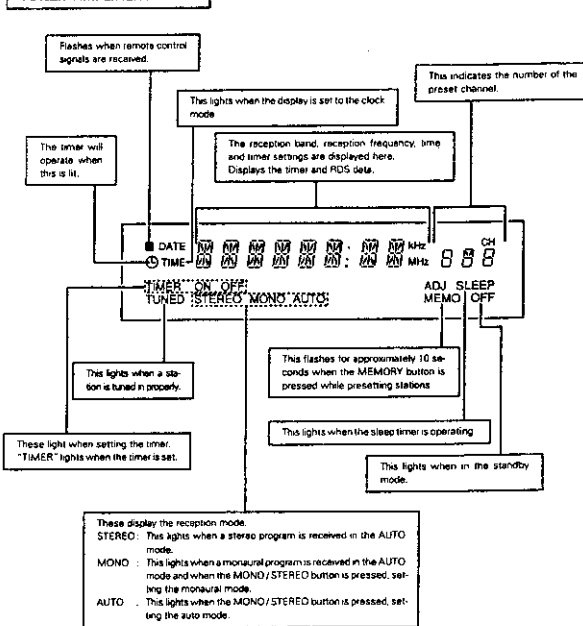

**NOTE:**  
• The timer standby mark (⏸) does not light if the current time and the timer have not been set.

6

**CD AUTO CHANGER**

- 1 Power operation switch (ON / STANDBY) button**  
Press this once to turn the CD auto changer's power on, then press again to set the CD auto changer to the standby mode. "OFF" appears on the display.
- 2 MIC (Microphone jack)**  
Plug the microphone plug into jack.
- 3 MIC VOL (Microphone volume control)**  
Use this to adjust the volume of microphone.
- 4 Display**
- 5 KARAOKE button**  
Press this to change the audio mode. (See page 20). The mode switches as follows each time the button is pressed:  
1st press: VR (Vocal Reduced)... The vocal signals of discs containing normal songs are decreased.  
2nd press: MONO-L... Only the left channel signals are output.  
3rd press: MONO-R... Only the right channel signals are output.  
4th press: No display... The normal stereo signals are output.
- 6 H-4 (automatic search reverse) button**  
Use this to move to the beginning of a specific track. When pressed during playback or in the pause mode, the pickup moves backward a number of tracks equal to the number of times the button is pressed.
- 7 KEY CONTROL buttons**  
Use these to adjust the key of the sound being played.  
+ The key increases by one half-note each time this button is pressed. (The key can be increased by up to three steps.)  
- The key decreases by one half-note each time this button is pressed. (The key can be decreased by up to three steps.)
- 8 H-4 (automatic search forward) button**  
Use this to move to the beginning of a specific track. When pressed during playback or in the pause mode, the pickup moves forward a number of tracks equal to the number of times the button is pressed.
- 9 [stop] button**  
Press this button to stop playback.
- 10 [PLAY] button**  
Press this button to start playing the disc. Even when the disc tray is open, the disc tray closes and playback begins when this button is pressed. When pressed in the standby mode, the power automatically turns on and playback begins. (Auto on function)
- 11 DISC button**  
Press this button to select the disc number. The Disc No. indicator changes each time the button is pressed. The disc whose indicator changes each time the button is pressed. The disc whose indicator is can be played.
- 12 [pause] button**  
Press this button to stop playback temporarily. Press the play button to cancel the pause mode and resume playback.
- 13 Disc tray**  
Load disc here.
- 14 OPEN / CLOSE button**  
Press this to open and close the disc tray. When pressed once, the disc tray opens out, and when pressed again, the disc tray closes. If a disc is loaded, the total number of tracks and total playing time of the disc are displayed several seconds after the disc tray is closed. When pressed in the standby mode, the CD auto changer's power turns on.

**CD AUTO CHANGER DISPLAY**

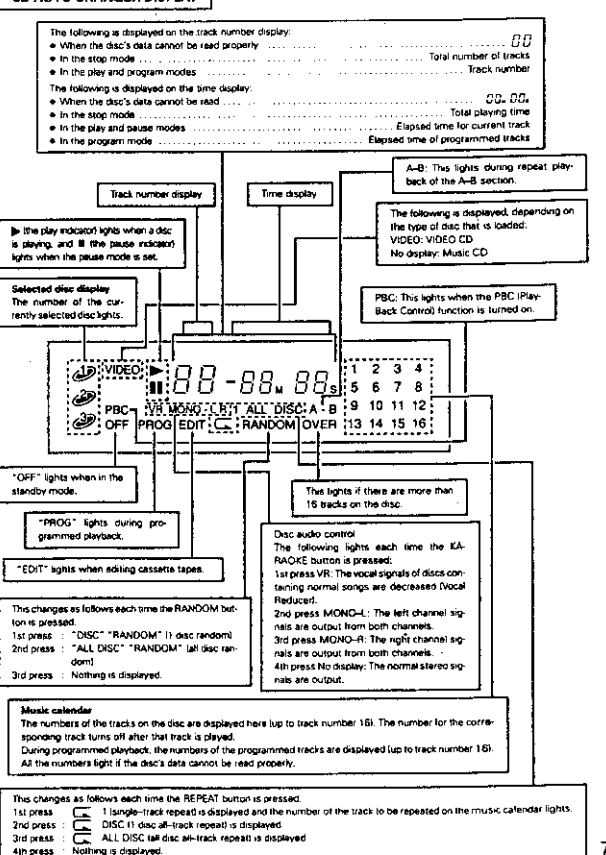

7

**GENERAL SECTION**  
**[For Asia model]**

**6 REMOTE CONTROL UNIT**

The D-M7 comes with a system remote control unit (RC-831).

**Inserting the batteries**

- NOTES:**
- Use R6P (AA) batteries in this remote control unit.
  - Replace the batteries with new ones approximately once each year, though this depends on how frequently the remote control unit is used.
  - Replace the batteries with new ones earlier if the remote control unit does not operate even from a short distance.
  - Insert the batteries in the proper + and - direction, following the marks in the battery compartment.
  - Remove the batteries when not using the remote control unit for extended periods of time.
  - To avoid damage and leakage:
    - Do not use a new battery with an old one.
    - Do not use two different types of batteries.
    - Do not short-circuit, take apart, heat or dispose of batteries in flames.
  - If the batteries should leak, carefully wipe the fluid out of the battery compartment, then insert new batteries.

① Open the battery compartment cover on the back of the remote control unit. Press the knob and open the cover in the direction of the arrow.



② Insert the two R6P (AA) batteries, following the + and - marks in the battery compartment.

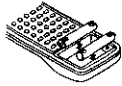

③ Close the cover of the battery compartment.

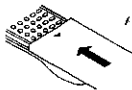

**Using the Remote Control Unit**

**Cautions on Use**

- The remote control unit may not operate if the remote sensor is exposed to direct sunlight or the strong light from a lighting fixture, or if there is an obstacle between the remote control unit and the remote sensor.
- Do not press buttons on the remote control unit and on the set at the same time. Doing so could result in malfunction.
- If the remote control unit is pointed away from the remote sensor during continuous operations (such as when turning the volume up or down), the operation will stop. If this happens, point the remote control unit at the remote sensor and press the button again.

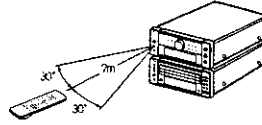

- The remote sensor is located on the pre-main amplifier. Point the remote control unit at the remote sensor as shown on the diagram when operating it.
- The remote control unit will operate from a direct distance of approximately 7 meters, but this distance will be shortened if obstacles are present or if operated at an angle. (The remote control unit will operate at an angle of up to 30° in either direction.)

8

**Remote Control Unit Part Names and Functions**

**CD operation buttons**

- ⏏ (stop) button: Press this button to stop playback.
- ▶ (play) button: Press this button to start playback.
- ⏮ and ⏭ (automatic search buttons): Use these buttons to search for the beginning of the desired track.

**FUNCTION selector button**

Press this button to switch the input (function). The input changes in the following order each time this button is pressed:  
CD → TAPE → TUNER → MD → AUX

**TUNER button**

Press this button to recall preset stations from the remote control unit using the number buttons.

**Number buttons**

Press these buttons after pressing the TUNER button to recall preset stations.

When playing a CD, press these buttons after pressing the DIRECT or PROGRAM button to specify the desired track.

**SDR (Super Dynamic Bass) button**

Press this for a sound with more powerful base.

**SLEEP button**

Press this button to set the sleep timer.

**REPEAT A-B button**

Press this for A-B repeat playback. (See page 16.)

**MENU button**

Press this to turn the PBC (PlayBack Control) function on and off. This button is effective at the stop mode.

**RETURN button**

Press this to return to the menu display.

**INTRO button**

Press this to display several still pictures on one screen to choose the track or scene to be played. (See page 19.)

**SLOW button**

Press this to set the slow play mode. (See page 19.)

**ON SCREEN button**

Press this to display character data (the video CD's operating status, settings, etc.) on the screen. (See page 20.)  
The TV screen display can only be used with video CDs.

**Casette deck operation buttons**

- ⏏ (stop) button: Press this button to stop the tape.
- ▶ (forward play) button: Press this to start playback or recording in the forward direction.
- ◀ (reverse play) button: Press this to start playback or recording in the reverse direction.

**POWER operation switch**

Use this switch to turn on the power of the entire system or set the power to the standby mode.

**PRESET buttons**

Use these buttons to recall preset stations on the tuner.

**VOLUME buttons**

Use these to adjust the volume. The volume increases when the ▲ button is pressed and decreases when the ▼ button is pressed.

**D. SKIP button**

Press this button to select the disc number. The DISC NO. indicator changes each time the button is pressed. The disc whose indicator it is can be played.

**MD recorder buttons**

- ⊙ (REC (recording) button)
- ⏮ (automatic search reverse) button
- ▶ (automatic search forward) button

**BAND (AM / FM) selector button**

**TUNING buttons**

**MEMO button**

**CD auto changer operation buttons**

- DIRECT button**: Press this button for direct search on the CD auto changer.
- ◀ and ▶ (manual search) buttons**: Press these buttons during playback to move quickly forward or backward.
- REPEAT button**: Press this button for repeat playback.
- RANDOM button**: Press this button to play the tracks in random order.
- PROGRAM button**: Press this button for programmed playback on the CD auto changer.
- CANCEL button**: Press this button to clear the last track from the program.
- EDIT button**: Press this button for edited recording on a tape, dividing the tracks onto sides A and B according to the length of the tape.
- TIME button**: Press this button during the play or pause mode to switch the time display. Normally the elapsed time for the track currently playing is displayed. When this button is pressed, the display switches to the:
  - remaining time for the track
  - total elapsed time on the disc
  - total remaining time on the disc
 then back to the elapsed time per track. During programmed playback, the total remaining time display indicates the total remaining time of the programmed tracks.

**Casette deck operation buttons**

- ⊙ (REC / REC MUTE) button**: To start recording from the stop mode, press this button, then press ◀, ▶. When this button is pressed during the recording, a blank section of approximately 5 seconds is created after which the recording standby mode is set.
- ◀ (rewind) button**: Press this button to rewind the top side of the tape. (The bottom side of the tape is fast-forwarded.) Also use this button to search for the beginning of the current selection when playing in the forward (▶) direction, or to search for the beginning of the following selection when playing in the reverse (◀) direction.
- ▶ (fast-forward) button**: Press this button to fast-forward the top side of the tape. (The bottom side of the tape is rewound.) Also use this button to search for the beginning of the following selection when playing in the forward (▶) direction, or to search for the beginning of the current selection when playing in the reverse (◀) direction.

**GENERAL SECTION**  
**(For Asia model)**

**7 LISTENING TO RADIO PROGRAMS**

(Check the connections on Pages 5 and 6.)

**TUNING**

Tuner-amplifier (UDRA-M7)

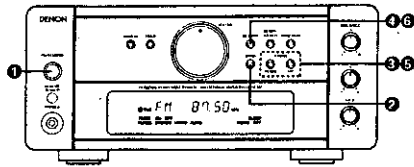

Example: Tuning in FM 87.50 MHz  
AM stations are tuned in using the same procedure.

1	Set the VOLUME control on the tuner-amplifier to the minimum position, then press the POWER operation switch to turn on the power.		
2	Press the BAND button on the tuner-amplifier to select the FM band.		
3	Use the TUNING UP and DOWN buttons to tune the frequency to 87.50. Once the frequency is tuned in, adjust the volume to the desired level using the VOLUME control.		

**Auto Tuning**

- When one of the TUNING buttons is pressed, the frequency changes in steps of 50kHz in the FM band, 5kHz in the AM band.
- Pressing the TUNING buttons is held in for over 1 second, the frequency continues to change when the button is released (auto tuning) and stops when a station is tuned in. Tuning will not stop at stations whose reception is poor.
- To stop the auto tuning function, press the UP or DOWN button once.

**Presetting AM and FM Stations**

Example: Presetting FM 87.50 (currently tuned in) as preset number 3

4	Press the MEMORY button. The <b>MEMO</b> indicator flashes for 10 seconds.		
5	Use the UP and DOWN buttons to call out the number at which you want to preset the station (3), or simply press the corresponding number button (3) on the remote control unit.		
6	Press the MEMORY button while the <b>MEMO</b> indicator is flashing.		

Up to 40 AM or FM stations can be preset using this procedure.

**NOTES:**

- In addition to the reception frequency, the reception mode (manual or auto) is also preset, so check the display when presetting stations.
- If a station is preset at a number where a station is already preset, the previous station is replaced with the new station.
- The preset memory is not cleared when the power cord is unplugged.

**Listening to Preset Stations**

The preset stations can be recalled using the number buttons on the remote control unit. Also, if the following operation is performed when the system power is off, the power automatically turns on and the radio is played. (Auto on function)

Example: Listening to the station preset at number 3  
(This operation is only possible from the remote control unit.)

1	Press the TUNER button on the remote control unit.		
2	Press button "3" on the remote control unit.		

**Receiving FM programs in stereo**

- Press the MONO/STEREO selector button to turn on the "AUTO" indicator. When a program being broadcast in stereo is received, the "STEREO" indicator lights and the program is received in stereo.
- If reception is poor and there is much noise in the stereo signals, press the MONO/STEREO selector button to set the manual mode.

**NOTE:**

- A humming sound may be heard when using a TV nearby while receiving AM programs. If this happens, move the system as far from the TV as possible.

**8 USING THE TIMER**

The time and timer functions are incorporated in the tuner-amplifier.

**Timer Settings**

**Types of timer operations**

- TIMER**: Use this to turn the power on and off at the same times every day.
- SLEEP TIMER**: Use this to set the power to turn off after 10 to 90 minutes, in steps of 10 minutes (operated from the remote control unit).

**Notes on timer settings**

- Be sure to set the current time beforehand.
- To listen to or record a radio program ("air check") using the timer, be sure to preset the station beforehand. (Refer to "Presetting AM and FM Stations" on Page 11.)

**Power Failures**

Should there be a power failure or should the power cord be unplugged, the time display will flash. If this happens, reset the current time. Also check the timer and tuner presettings, and reset them if they have been cleared.

**Checking the Settings**

To check the timer settings, press the TIMER button for at least 4 seconds. (This can also be done when the tuner's power is off.) Next, press the MEMORY button repeatedly to display the timer start mode, the reception band and preset channel number when in the timer mode, the on time and the off time. Press the MEMORY button once more to return to the current mode display.

**Changing the Settings**

Repeat the timer setting operation to erase the previous settings and set the new settings.

**Clearing the Settings**

Press the TIMER button for at least 4 seconds, then press it for at least 4 seconds again while "FUNC" is displayed to clear the timer settings.

**Note on Setting the Timer**

If the time set with the timer is reached while the system power is on, the operation switches to the operation set by the timer.

**Turning the Timer Off**

Press the TIMER button to turn the mark off.

**Setting the Current Time**

The time is displayed in the 24-hour mode.

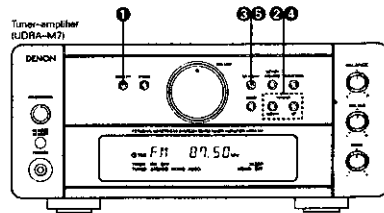

Example: Setting to 19:30 (7:30 p.m.)

1	Press the DISPLAY button for at least 4 seconds.			The hours place flashes. (If the hours have already been set, that number flashes.)
2	Use the UP and DOWN buttons to set the hours.			The hours place flashes.
3	Press the MEMORY button.			The minutes place flashes. (If the minutes have already been set, that number flashes.)
4	Use the UP and DOWN buttons to set the minutes.			The minutes place flashes.
5	Press the MEMORY button at the sound of a time service's chime. The time display stops flashing and the clock starts running.			The display stops flashing and the clock starts running from 00 seconds.

The current time can be set even when the power is off.

**GENERAL SECTION**  
**[For Asia model]**

**Setting the Timer**

The power can be set to turn on and off every day at the same time in any of six modes: CD, TAPE, TUNER, MD, AIRCH (recording from the radio onto the cassette deck) and AIRCH MD (recording from the radio onto the MD recorder).

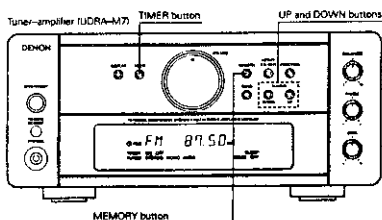

Example: Setting the timer to turn on at 12:36, off at 12:56 (with FM 87.50 MHz preset at channel "3")

1	Press the POWER operation switch on the tuner-amplifier to turn on the system's power.		
2	Press the TIMER button for at least 4 seconds to set the timer setting mode.		
3	Use the UP and DOWN buttons to set the "TUNER" mode.		
4	Press the MEMORY button.		
5	Use the UP and DOWN buttons to set the preset channel number.		
6	Press the MEMORY button.		
7	Use the UP and DOWN buttons to set the hours for the timer on time.		

12

8	Press the MEMORY button.		
9	Use the UP and DOWN buttons to set the minutes for the timer on time.		
10	Press the MEMORY button.		
11	Use the UP and DOWN buttons to set the hours for the timer off time.		
12	Press the MEMORY button.		
13	Use the UP and DOWN buttons to set the minutes for the timer off time.		
14	Press the MEMORY button.		
15	Press the TIMER button.		
16	Press the POWER operation switch on the tuner-amplifier to turn off the system's power.		

If the is displayed after the TIMER button is pressed, the timer will operate at the same times every day. To turn it (turn) off, press the TIMER button again to turn the mark off.

**NOTE**

- The standby mark () will not light if the current time is not set. If it is the case, set the current time, then press the TIMER button.
- Be sure to set the power to the standby mode when using the timer.

**Various Timer Operations**

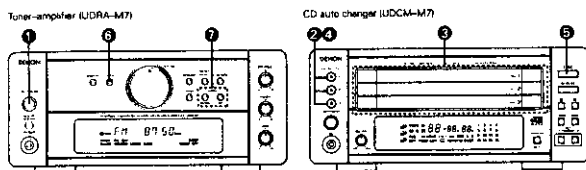

Example 1: Playing a compact disc with the timer

1	Press the POWER operation switch on the tuner-amplifier to turn on the system's power.		
2	Press the CD auto changer's OPEN/CLOSE button to open the disc tray.		
3	Load the disc in the disc tray. Refer to Page 16.		
4	Press the CD auto changer's OPEN/ CLOSE button again to close the disc tray.		
5	Press the DISC button to select the disc to be played.		
6	Press the tuner-amplifier's TIMER button for at least 4 seconds.		
7	Use the tuner-amplifier's UP and DOWN buttons to set the "CD" mode.		
8	Now follow steps 6 to 16 under "Setting the Timer" on Page 13.		

**Setting the Sleep Timer**

With this function, the power can be set to turn off after 10 to 60 minutes, in steps of 10 minutes, using the remote control unit.

Example: To turn the power off after 50 minutes when listening to FM 87.5 MHz (This operation is only possible from the remote control unit.)

1	Tuner currently set to FM 87.50 MHz.	
2	Press the SLEEP button.	
3	Press the SLEEP button again while the "SLEEP" indicator is flashing.	
4	The previous display reappears after 5 seconds. The "SLEEP" indicator remains lit, indicating that the sleep timer is functioning.	

The time is reset to "60" (60 minutes) if the SLEEP button is pressed again while the sleep timer is functioning.

**Cancelling the Sleep Timer**

Press the SLEEP button repeatedly until the "SLEEP" indicator turns off. The sleep timer is also cancelled if the tuner-amplifier's Power operation switch (ON/STANDBY) or the POWER switch on the remote control unit is pressed, turning the system power off.

**NOTE:**

If the times set with the sleep and everyday timers overlap, the sleep timer has priority.

**Order of priority of the sleep and everyday timers**

The sleep timer has priority for the off time. (The system operates as indicated by the bold lines.)

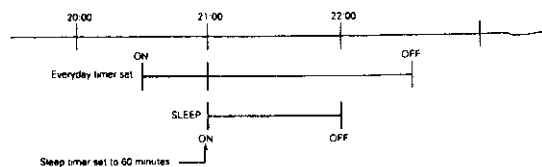

Even when the power was turned on with the timer, the power turns off if the remaining time of the sleep timer reaches 0 before the off time set with the everyday timer is reached. If the everyday timer's on time is reached while the sleep timer is functioning, the everyday timer does not function.

13

**GENERAL SECTION**

**(For Asia model)**

**9 PLAYING CDs**

**About Compact Discs**

**Playable discs**

The types of discs that can be played on the D-M7 are listed below. The marks are located on the disc's label or jacket.

Mark	Disc	Size	Recorded side	Audio recording system	Video recording system
	Video CD single	8 cm	One side	Digital	Image compression
	Video CD	12 cm	One side	Digital	Image compression
	CD graphics single	8 cm	One side	Digital	CD-G
	CD graphics	12 cm	One side	Digital	CD-G
	CD (Compact Disc) single	8 cm	One side	Digital	—
	CD (Compact Disc)	12 cm	One side	Digital	—

**CDs (Compact Discs)**

These are digital audio discs containing music.

**Video CDs**

These are CD-size discs containing image and audio signals using moving picture compression technology. When played, the player restores the compressed signals recorded on the disc to their original form.

**CD-Gs (CD graphics)**

CD-Gs are discs containing still pictures or character data in addition to regular CD audio signals. When using CD-Gs for karaoke, the still pictures and lyrics are displayed after the title.

**NOTES:**

- The D-M7 is compatible with Version 2.0 format video CDs. Discs in Version 1.1 format can also be played.
- The D-M7 is designed for use with NTSC and PAL systems. Discs with images for other TV systems (ISCAI, etc.) cannot be used on the D-M7.
- Either an NTSC or a PAL type TV (or monitor) can be connected to the D-M7. Set the VIDEO OUT switch on the rear panel to either the NTSC or PAL side, according to the type of TV connected.  
Note that pictures will not be displayed properly if an NTSC disc is used with a PAL TV (or monitor) or vice versa. Make sure the disc and TV (or monitor) are of the same type.
- It is prohibited by law to copy, broadcast, screen, cable-broadcast, play in public, rent or lend discs.
- The picture may be distorted when the pause, A-B repeat and search modes are set while playing a CD-G disc.

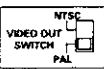

Only discs with the mark shown left can be played on the D-M7

Use compact discs that include the mark.

CDs with special shapes (heart-shaped CDs, octagonal CDs etc.) cannot be played on this set. Attempting to do so may damage the set. Do not use such CDs.

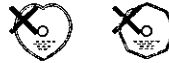

• For CDVs, only the audio part is played. (The video part is not played.)

**Removing discs from their cases**

As shown on the diagram, grasp the outer edge of the disc with your fingers, insert a finger in the center hole, press gently, then lift the disc out of the case.



**Loading discs in the disc tray**

Be sure to load the disc with the labelled side facing up. (Compact discs only play on one side.) For 8cm CDs, set the disc in the sunken section in the center of the tray.

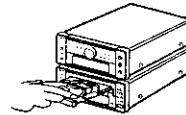

**NOTES:**

- The disc tray opens when the OPEN / CLOSE button is pressed once and closes when it is pressed again.
- When the disc tray is closed, the disc turns automatically for several seconds, then the total number of tracks and total playing time of that disc appear on the display.
- The disc tray can also be closed by pressing the PLAY button, in which case playback automatically starts from the first track on the disc (or if tracks are programmed, from the first programmed track).

**Handling the Disc Tray**

Do not turn off the power, stop the disc tray by hand or pull it when it is moving. Doing so may damage it. If the headphones' cord or some other object accidentally gets caught in the disc tray while it is closing and the disc tray stops, press the OPEN / CLOSE button again to open the tray and remove the obstacle. Do not set objects other than discs on the disc tray. Doing so may damage it.

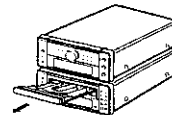

**Normal Playback**

CD auto changer (UDCM-M7)

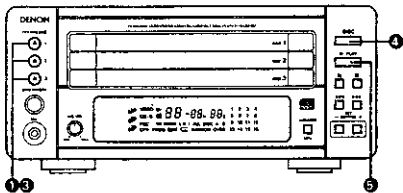

CD auto changer (UDCM-M7)

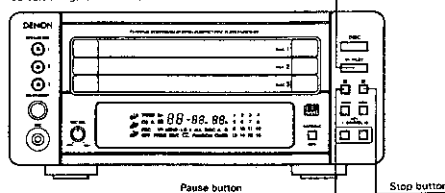

Example: Playing a disc containing 16 tracks and with a playing time of 62 minutes, 03 seconds, starting from the first track

The mark indicates operations which can also be performed on the remote control unit.

1	Press the  OPEN / CLOSE button of the disc tray you want to open the disc tray.		OP ER
2	Load the CD in the disc tray.		
3	Press the  OPEN / CLOSE button. The disc tray closes. The display appears after several seconds.		15 62.03.
4	Press the  DISC button to select the disc to be played.		
5	Press the  PLAY button.		01 00.04.

**Interrupting playback temporarily**

Press the  (pause) button.		The "II" mark appears on the display, and playback stops at the point where the button was pressed.
----------------------------	--	---

• The picture may be disturbed when the pause mode is set while playing a CD-G disc.

**Resuming playback**

Press the  PLAY button.		The "II" mark turns off on the display, and playback resumes from the point where the pause button was pressed.
-------------------------	--	---

**Stopping playback**

Press the  (stop) button.		15 62.03.
---------------------------	--	-----------

**NOTES:**

- When a disc is loaded, "00.00." is displayed on the display for several seconds while the data on the number of tracks and total playing time is being read from the innermost side of the disc, after which the number of tracks and total playing time appear.
- If no disc is loaded, if the disc is upside down, or if the data cannot be read properly due to scratches or dirt, the display reads as shown below and the disc will not play.

00 00.00.



**GENERAL SECTION**  
**(For Asia model)**

**Various Playback Functions**

In addition to the regular playback, the D-M7 also offers the following playback functions:

**1 Playing a specific track**

(Using the remote control unit)  
Example: Playing the 8th track

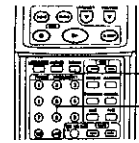

Direct button  
"8"

**Direct Search**

- Press the DIRECT button.
- Press the button corresponding to the number of the track 8. "8" appears on the track number display and playback of track number 8 begins.
  - When the end of the track is reached, playback continues on the next track.
  - To specify a track number of 11 or greater, say track 15, press [15] then [1].
  - To specify a track number of 20 or greater, say track 23, press [2-0] [1-0] then [3].
  - To play track 20, press [2-10] then [0].

**2 Playing a single track repeatedly**

(Using the remote control unit)

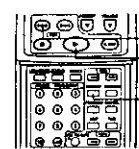

REPEAT button  
Play button (▶)

**Single-track Repeat**

- When the REPEAT button is pressed once, [REPEAT] appears on the display and the single-track repeat mode is set.
  - Use the [◀] and [▶] buttons to select the track to be repeated.
  - Press the play button [▶] to start playback.
    - When the end of the specified track is reached, playback starts over from the beginning of that track.
    - The single-track repeat mode can also be set by pressing the REPEAT button once during playback.
    - To cancel the single-track repeat mode, press the REPEAT button repeatedly until the [REPEAT] indicator turns off.
- NOTE: This function will not work when the PBC function is turned on with video CDs (Ver. 2.0).

**3 Playing all the tracks repeatedly**

(Using the remote control unit)

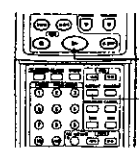

REPEAT button  
Play button (▶)

**All-track Repeat**

- When the REPEAT button is pressed twice, [DISC] appears on the display and the all-track repeat mode is set.
  - Press the play button [▶] to start playback.
    - The all-track repeat mode can also be set by pressing the REPEAT button twice during playback.
    - To cancel the all-track repeat mode, press the REPEAT button to turn the [DISC] indicator off.
    - If the REPEAT button is pressed during programmed playback, the tracks are played repeatedly in the programmed order.
- NOTE: This function will not work when the PBC function is turned on with video CDs (Ver. 2.0).

**4 Playing all the disc repeatedly**

(Using the remote control unit)

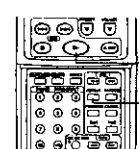

REPEAT button  
Play button (▶)

**All-disc Repeat**

- When the REPEAT button is pressed, [ALL DISC] appears on the display and the all-disc repeat mode is set.
  - Press the play button [▶] to start playback.
    - The all-disc repeat mode can also be set by pressing the REPEAT button 3 times during playback.
    - To cancel the all-disc repeat mode, press the REPEAT button to turn the [ALL DISC] indicator off.
    - If the REPEAT button is pressed during programmed playback, the tracks are played repeatedly in the programmed order.
- NOTE: This function will not work when the PBC function is turned on with video CDs (Ver. 2.0).

16

**NOTES:**

- The numbers of the programmed tracks on the music calendar turn off after the tracks have been played.
- With this CD auto changer, up to 16 tracks with any track number between 1 and 99 can be programmed.
- If a number greater than the number of tracks recorded on the disc is programmed, that number is skipped during programmed playback.
- The program settings are retained until the program is cleared.
- If a number greater than the total number of tracks on the disc is specified, that number will not be displayed.
- Programming is also possible with the disc tray open. In this case it is possible to program a track number not included on the disc, but when the program is played, that track number will be skipped.
- If you make a mistake when programming, press the CANCEL button to cancel the mistake. (If the last track in the program is cancelled each time the CANCEL button is pressed.)
- Set the stop mode when cancelling tracks from the program.

**7 Moving ahead to the next track during playback**

CD auto changer (JDCM-M7)

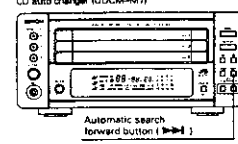

Automatic search forward button (▶)

Press the automatic search forward button (▶).

**Quick Search**

**8 Moving back to the beginning of the track during playback**

CD auto changer (JDCM-M7)

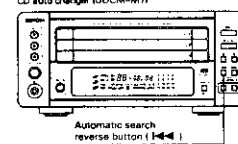

Automatic search reverse button (◀)

Press the automatic search reverse button (◀).

**Quick Search**

**9 Playing a certain section repeatedly**

(Using the remote control unit)

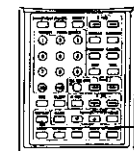

REPEAT A-B button

**A-B Repeat**

- During playback, press the REPEAT A-B button at the point where you want to start repeating (A). "A" appears on the display and the A-B repeat mode is set.
- Press the REPEAT A-B button again at the point where you want to stop repeating (B). "A" and "A-B" appear on the display, the pickup returns to point A, and playback of the A-B section begins.
  - To cancel the A-B repeat mode, press the REPEAT A-B button to turn the "A" and "A-B" indicators off.
  - There must be a space of at least 3 seconds between points A and B.

**10 Playing the tracks in a certain order**

(Using the remote control unit)

Procedure

<b>1</b>	Press the PROGRAM button.	
<b>2</b>	Press the 0 SKIP number and +10 buttons to select the disc to be programmed. For example, to program the 3rd track on the 2nd disc and the 12 track on the 3rd disc, press [02] [03] [12] [10] [03] [12]. The display shows "Flash" and "P-02".	
<b>3</b>	Press the play button.	

The tracks are played in the programmed order.

- When the TIME button is pressed before playback, the total playback time of programmed tracks is displayed.
- Press the DIRECT button to resume normal playback during the programmed playback.
- To cancel the entire program, press the DIRECT button or cancel the program one by one using the CANCEL button.
- If you program the wrong track, press the CANCEL button then program the right track. (The last track in the program is erased each time the CANCEL button is pressed.)

**Other operations possible during programmed playback:**

- Such operations as quick search, pause and skip monitor are also possible during programmed playback.
- For the quick search function, press the automatic search reverse button [◀] to move back to the beginning of the track, then press it again while the time display reads "00:00" to move back to the beginning of the preceding track.
- To move ahead to the beginning of the next track, press the automatic search forward button [▶], regardless of the time display.

**11 Finding a certain spot on the disc while listening to the sound**

(Using the remote control unit)

Manual search forward button (▶)

Manual search reverse button (◀)

Forward skip monitor

(Using the remote control unit)

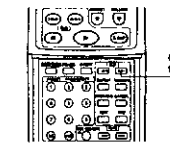

Manual search forward button (▶)

During playback, press and hold in the manual search forward button [▶] to skip through the disc in the forward direction while listening to the sound.

**12 Reverse skip monitor**

(Using the remote control unit)

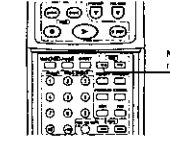

Manual search reverse button (◀)

During playback, press and hold in the manual search reverse button [◀] to skip through the disc in the reverse direction while listening to the sound.

- The track currently being monitored and the elapsed time to that track are indicated on the display.
- If the manual search forward button [▶] is held in until the end of the disc is reached, the next disc is selected.
- If the manual search forward button [▶] is held in until the end of disc 3 is reached, the stop mode is set.

**13 Playing all the tracks on the disc in random order**

(Using the remote control unit)

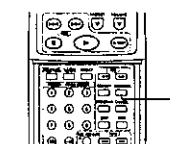

RANDOM button

**All-track Random**

- Press the RANDOM button once in the stop mode. "RANDOM" and "DISC" appear on the display and the all-track random mode is set.
- If the RANDOM button is pressed during repeat playback, the tracks are played once in random order, then playback again in a different order, and this is repeated.
- To cancel the all-track random mode, press the STOP button to turn the "RANDOM" and "DISC" indicators off.
- The track numbers that can be played in random order are track numbers 1 to 99.

**NOTES:**

- The total remaining time cannot be displayed during the all-track random mode.
- The all-track random mode cannot be set during editing.
- The single-track repeat mode cannot be set during random playback.
- This function will not work when the PBC function is turned on with video CDs (Ver. 2.0).

**GENERAL SECTION**  
[For Asia model]

**1 Playing all the tracks on all the discs in random order**  
(Using the remote control unit)

All-disc Random

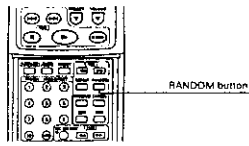

- In the stop mode, press the **RANDOM** button twice.
  - The "RANDOM" and "ALL DISC" indicators light, and the tracks from all the discs are played in random order.
  - If the **RANDOM** button is pressed in the repeat play mode, all the tracks are played once in random order, then played again in a different order, and this is repeated.
  - To cancel the all-track random mode, press the **STOP** button to turn the "RANDOM" and "DISC" indicators off.
  - The track numbers that can be played in random order are track numbers 1 to 33 on the different discs.

**NOTES:**

- The total remaining time cannot be displayed during the all-track random mode.
- The all-track random mode cannot be set during editing.
- The single-track repeat mode cannot be set during random playback.
- This function will not work when the PBC function is turned on with video CDs (Ver. 2.0).

**Edited Recording on Sides A and B of a Tape**

This function allows edited recording according to the size of the tape. (This operation is only possible from the remote control unit.) Edited recording is a system function of the D-M7 series. This function can only be used in combination with the DRR-M7.

- Use this function to efficiently edit the tracks on a CD according to the length (time) of the tape onto which you want to record.

**NOTES:**

- In the edited recording mode, it is programmed so that the remaining time of the tape becomes minimum and the last programmed track may be out of line on both side. If you want to make serial track recording in this case, use the **CD SPS** button after stopping the edited recording mode.
  - Load the cassette tape onto which you want to record in the cassette deck with side A on the top before starting the editing procedure. The tape is automatically wound to the beginning before recording starts.
  - The editing mode is cancelled when the **CD auto changer's stop** button is pressed.
  - Note that even if the tape is slightly longer than the disc's total playing time, it may not be possible to record all the tracks on sides A and B because of the combination of tracks to be recorded on the different sides of the tape.
  - When recording on an already recorded tape, if the tape is longer than the new recording, the previous recording will remain at the end of side B, so erase the tape before starting.
  - To protect the recording, do not press the **FUNCTION** (input selector) button during edited recording.
  - During edited recording, only the **stop**, **POWER** switch, and **TIME** button for the **CD auto changer** and the **RESET** button, **stop**, **DOLBY NR** button, and **POWER** switch for the **cassette deck** will function.
  - Blank sections of 5 seconds are automatically created between all the selections to make it easier to search for selections on tapes recorded on the system. Since this differs from the actual time between tracks on the CD, the displayed time and the actual remaining time on the tape differ slightly.
  - Set the reverse mode on the cassette deck (DRR-M7) to **▶** or **◀** during edited recording.
  - The total remaining time cannot be displayed during the programmed edited recording.
  - When using the editing function with discs containing more than 21 tracks, only 20 tracks can be edited.

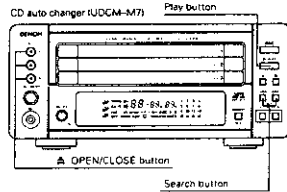
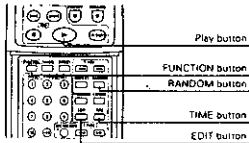

**2 Recording the tracks in the same order as on the disc**

Automatic Edited Recording

Example: Recording a disc containing 16 tracks and a total playing time of 56 minutes on a C-60 cassette tape

1	Press the <b>CD auto changer's OPEN/ CLOSE</b> button to open the disc tray. Load the disc in the disc tray.		
2	Press the <b>OPEN/ CLOSE</b> button to close the disc tray. The display appears after several seconds.		
3	Press the <b>FUNCTION</b> button on the tuner-amplifier to set the CD mode.		
	Press the <b>EDIT</b> button on the remote control unit to set the length of the tape. (The length is the total for sides A and B.) For a 60-minute (C-60) tape, press the <b>EDIT</b> button 2 times.		Load the cassette tape onto which you want to record in the cassette deck with side A facing up.
4	The display changes as shown below each time the <b>EDIT</b> button is pressed. (If the tape length has already been set once, the display changes starting from that length.)  Inputting other tape sizes: To input other tape sizes, use the number buttons when "C---" is displayed.		Example: For a 60-minute tape 
5	After this, the remaining times for sides A and B are displayed alternately for several seconds each.		
6	Press the <b>play</b> button on the remote control unit or the <b>CD auto changer</b> .		
7	The tape is automatically wound to the beginning on the cassette deck, then recording starts.		

• To set a time other than 45, 60 or 90, input the time when "C---" is displayed. The time can be set up to 99 minutes. The time is input in the same way as when inputting track numbers for the CD direct search operation.

**Playing Video CDs**

**1 Selecting and playing tracks using the menu function**

Menu Function

- The menu function can be used to select and play tracks for video CDs with PBC (PlayBack Control).
- Also carefully read the explanation included with the disc.
- This function will not work for video CDs without PBC, CD-Gs or regular CDs. Use normal playback for such discs.

(Using the remote control unit)

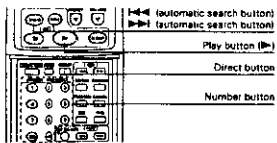

- Load the disc then press the **▶** (PLAY) button. The menu appears on the display.
- Use the automatic search reverse (**◀**) and automatic search forward (**▶**) buttons to switch the menu screen.
  - Press the automatic search forward button (**▶**) to move forward to the next screen.
  - Press the automatic search reverse button (**◀**) to move back to the previous screen.
- Press the **DIRECT** button, then use the number buttons to select the desired number. Playback of the track with the selected number begins.
  - To stop playback, press the **STOP** button.
  - To stop playback and return to the menu screen, press the **RETURN** button.

**NOTES:**

- If the menu screen is still displayed once the track has stopped playing, the disc is still spinning. If you do not want to play another track, be sure to press the **STOP** button to turn off the menu screen.
- With some discs, playback will start automatically if nothing is done while the menu screen is displayed.

**2 Selecting the track from a screen displaying various tracks**

Intro Scan Function

- The track or scene can be selected from a single screen displaying several still pictures.
- For discs with PBC (PlayBack Control), press the **MENU** button while in the stop mode and first set the normal play mode.
- This function cannot be used with music CDs and CD-Gs.

**(1) Searching for tracks on a single disc**

- Use this function to select a track from a screen displaying the first scenes from up to 9 tracks on the disc.

(Using the remote control unit)

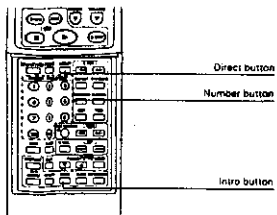

- Press the **INTRO** button while the stop mode. Still pictures of the first scenes in tracks 1 to 9 of the currently selected disc are displayed.
  - To search for track numbers 10 and over, press the automatic search forward button (**▶**). (Still pictures of the first scenes in tracks 10 to 19 of the currently selected disc are displayed.)
  - To return to the previous screen, press the automatic search reverse button (**◀**).
- Press the **DIRECT** button, then use the number buttons to select the desired number. Playback of the track with the selected number begins.
  - To cancel the intro scan mode, press the **STOP** button.

**(2) Searching for scenes within a track**

- Use this function to divide a single track into 9 parts and display the first scenes of each part to select the desired scene. This function comes in handy when you want to start playing from the middle of movie, etc., that is not divided into many tracks.

(Using the remote control unit)

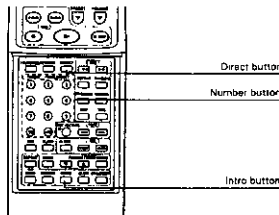

- Press the **INTRO** button during playback. Still pictures of 9 scenes in the track are displayed in order.
- Press the **DIRECT** button, then use the number buttons to select the desired number. Playback begins. (In some cases playback may not start from exactly the scene displayed.)
  - To cancel the intro scan mode, press the **STOP** button.

**(2) Playing pictures slowly**

Slow Play

(Using the remote control unit)

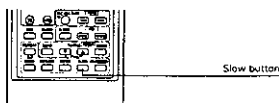

- Press the **SLOW** button while in the play or pause mode with a video CD. Slow playback begins. No sound is produced during slow playback.
  - The speed switches between 1/4, 1/8 and normal speed each time the **SLOW** button is pressed.

**GENERAL SECTION**  
[For Asia model]

**Using the Karaoke Functions**

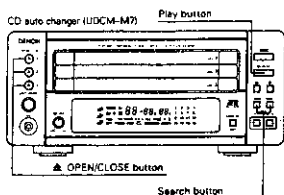

- Using the microphone**
  - You can sing karaoke by connecting a separately sold microphone to the microphone jack.
  - Turn the microphone volume control counter-clockwise and set it to the "MIN" position.
  - Connect the microphone to the microphone jack.
  - Turn the microphone volume control clockwise and set it to the desired position.
- Setting a comfortable key**
  - The key of the track can be increased or decreased.
  - The key increases by one half-note each time the "+" button is pressed. (The key can be increased by up to three steps.)
  - The key decreases by one half-note each time the "-" button is pressed. (The key can be decreased by up to three steps.)
  - NOTE:** The key control setting is stored in the memory until the power is turned off.
- Singing karaoke using the KARAOKE button**
  - You can sing karaoke by reducing the vocal signals of CDs containing regular songs.
  - For CDs, etc., on which the music and vocals are split between the left and right channels, you can output only the left or right channel.
  - The mode switches as follows each time the button is pressed:
    - 1st press: VR (Vocal Reducer) ... The vocal signals of discs containing normal songs are decreased.
    - 2nd press: MONO-L ... Only the left channel signals are output.
    - 3rd press: MONO-R ... Only the right channel signals are output.
    - 4th press: No display ... The normal stereo signals are output.

**NOTES:**

- The Vocal Reducer may not provide sufficient vocal reduction for the following types of discs or tracks:
  - Multiple audio discs
  - Discs recorded in monaural
  - Songs using only a few instruments
  - Dusts
  - Tracks on which the vocals are not centered

**TV screen display**

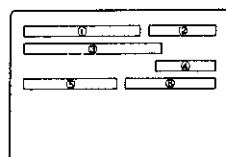

- Operation display section**  
DISC( ) OPEN, DISC( ) CLOSE, READING, DISC( ) MENU ON, MENU OFF, OSD ON, OSD OFF, PROGRAM DISC( ), RANDOM DISC( ), TIME (T) ( ) ( ), DISC INTRO, TRACK INTRO
- Mode display section**  
PLAY, STOP, PAUSE,   
◀ SLOW, SLOW2, NEXT, PREV, RETURN, SELECT
- Track number display section**  
TRACK ( ) ( ), SELECT ( ) ( )  
TRACK ( ) ( ) No. ( ) ( )
- Repeat display section**  
A- A ( ) B- B ( ) TRACK, U DISC, U ALL DISC, U OFF
- Karaoke mode display section**  
VR, MONO R, MONO L
- Key control display section**  
+ - - - - -

• The TV screen display can only be used with video CDs.

**10 AUTO ON FUNCTION**

- When the play button or OPEN/CLOSE button on the CD auto changer, cassette deck (optional) or MD recorder (optional) is pressed while the power is set to the standby mode, the power automatically turns on and the play or open/close operation is performed.
- In the same way, when the tuner-ampifier's preset up/down buttons on the remote control unit is pressed, the power turns on and the corresponding station is tuned in.

**11 OTHER INFORMATION**

**Cleaning Discs**

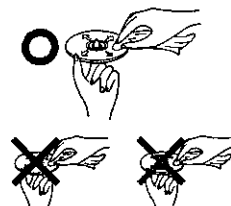

Dust, fingerprints or spit on the disc will result in noise or skip ping. If the disc is dirty or the CD auto changer does not operate properly, use the following procedure to clean the disc:

- Hold the disc with the signal surface the side opposite the labelled side facing up, as shown in the diagram.
- Wipe the disc gently from the center towards the edge in the direction of the arrow with a soft cloth.

Do not clean discs with the following:

- Benzene, alcohol or other solvents
- Cleaner including an abrasive
- Sprays or cleaners designed for records
- Anti-static

**NOTES**

- Do not wipe discs in the direction opposite the arrow or in a circular motion as with regular records.
- The disc's signal surface is easily damaged, so do not wipe it with a hard cloth or rub it strongly.

**12 SPECIFICATIONS**

- Tuner-ampifier (UDRA-M7)**
    - Reception frequency band: FM: 87.50 MHz - 108.00 MHz; AM: 522 kHz - 1611 kHz; FM: 1.5 μV/75 Ω/ohms; AM: 20 μV; 35 dB (1 kHz); 30 W + 30 W (5 Ω / ohms, DIN); 100 Hz ± 8 dB; 10 kHz ± 8 dB
    - FM stereo separation: 30 W + 30 W (5 Ω / ohms, DIN)
    - Rated output power: 100 Hz ± 8 dB; 10 kHz ± 8 dB
    - Low frequency adjustment range: CD input jacks, tape input/output jacks, AUX input jacks, MD input/output jacks, 3.5 mm headphones jack
    - High frequency adjustment range: AC 230 V, 50 Hz; 55 W
    - Audible input/output jacks: 210 (W) × 95 (H) × 323 (D) mm (8-17/8" × 3-45/64" × 12-7/8") (including feet, controls and terminals); 3.5 kg (7 lbs. 11 oz)
  - CD auto changer (UDCM-M7)**
    - Wow & flutter: Below measurable limits (±0.001% W, peak)
    - Sampling frequency: 44.1 kHz
    - Optical source: Semiconductor
    - Power supply: AC 230 V, 50 Hz
    - Power consumption: 12 W
    - Maximum external dimensions: 210 (W) × 97 (H) × 343 (D) mm (8-17/8" × 3-45/64" × 13-5/16") (including feet, controls and terminals); 3.0 kg @ lbs. 13 oz
  - Remote control unit (RC-83)**
    - Remote control system: Infrared pulse
    - Number of buttons: 47
    - Power supply: Two DC 1.5V R6P/AA batteries
    - Maximum external dimensions: 67 (W) × 197 (H) × 21 (D) mm (2-41/64" × 7-3/4" × 53/64")
    - Weight: 145 g (including batteries) (Approx. 4.6 oz)
- \* Maximum dimensions include controls, jacks, and covers.  
W = width, H = height, D = depth  
• For improvement purposes, specifications and functions are subject to change without advanced notice.

**13 TROUBLESHOOTING**

Check the following once more before assuming there is a problem with the system.

- Are connections proper?
- Is the system being operated as explained in the operating instructions?

If the system does not seem to be operating properly, check as shown on the table below. If none of these checks apply to the problem, the system may be malfunctioning. Disconnect the power cord immediately and contact your store of purchase.

	Symptom	Cause	Countermeasure	Page
General	Power does not turn on when power operation switch is pressed.	• Power cord is not plugged into a power outlet	• Plug the power cord securely into an outlet	5
	No sound is produced from the speakers	• VOLUME control is turned down. • Headphones are connected. • Speaker cords are not securely connected.	• Set the control to an appropriate position. • Disconnect the headphones • Connect securely.	6 6 5
	No trouble sound is produced, or the position of the instruments is unclear	• Speaker polarities (B and G) are inverted.	• Connect the speaker cords properly	5
Tuner-ampifier	A source other than the desired one is heard.	• Function is not properly set	• Set the desired function using the FUNCTION button	6
	Hissing sound is heard in FM programs.	• Antenna direction is poor. • Signals from the broadcast station are weak.	• Change the direction of the antenna. • Install an outdoor antenna.	4
	Hissing sound is heard in AM programs.	• Noise from a TV or interference from a broadcast station.	• Turn the TV off. • Change the direction of the loop antenna. • Install an outdoor antenna.	- - 4
CD auto changer	Humming sound is heard in AM programs.	• Signals on the power cord are being modulated by the power source frequency	• Insert the power cord in the opposite direction • Install an outdoor antenna	- 4
	Total number of tracks not displayed when disc is loaded	• Disc is loaded upside-down. • Disc is dirty. • Disc is not of the specified type.	• Reload the disc. • Clean the disc. • Replace with a disc of the specified type.	16 20 -
	Nothing happens when operating buttons are pressed. Disc stops in the middle of a track and will not play properly.	• Disc is loaded upside-down. • Foreign object on disc tray. • Disc is dirty. • Disc is scratched.	• Reload the disc. • Remove the disc and the foreign object. • Clean the disc. • Replace with an unscratched disc.	16 18 20 -
	Sound is broken	• Dirt, fingerprints, spittle, etc. on disc • Disc is scratched. • Player is in an unstable place and vibrates strongly	• Clean the disc • Replace with an unscratched disc. • Place the player in a stable place with no vibrations.	20 -
	Humming sound is heard when disc is played	• Signals on the power cord are being modulated by the power source frequency	• Insert the power cord in the opposite direction	-

**Protector circuit**  
The UDRA-M7 is equipped with a high speed protector circuit. This circuit protects internal parts from being damaged by strong currents generated in the set should the set be operated when its speaker terminals are incompletely connected or short-circuited. If this protector circuit is activated, a relay sound is produced, the output to the speakers is interrupted, and if the function and power LED flash to indicate that there is a problem. If this should happen, unplug the power cord, check the speaker connections, then plug in the power cord and turn the power back on. After several seconds, a relay sound is heard and the set starts operating properly.

• The set may not operate properly due to such external influences as lightning or static electricity. If this happens, either turn off its power with the tuner-ampifier's POWER operation switch or unplug the power cord, wait approximately 5 seconds, then plug its power cord back in.

## RECEIVER SECTION

## DISASSEMBLY

(Follow in the reverse order for reassembly)

## 1. Top Cover

- (1) Remove 2 screws ① fixing from the both sides.
- (2) Remove 5 screws ② fixing to the Rear Panel.
- (3) Detach the Top Cover in the arrow direction.

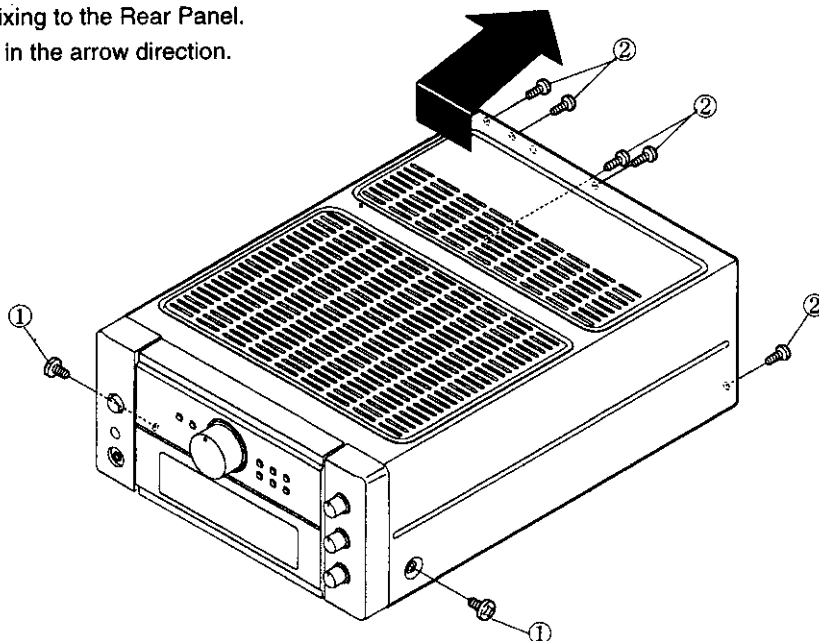

## 2. Front Panel

- (1) Remove 4 screws ③ fixing the Front Panel at the bottom.
- (2) Disconnect 3 connectors coming from the Front P.W.B. and 1 connector coming from the Main P.W.B.
- (3) Disconnect 2 (1 : for Asia model) FFC cables from the Main P.W.B.
- (4) Release 2 hooks at the both sides, then detach the Front Panel.

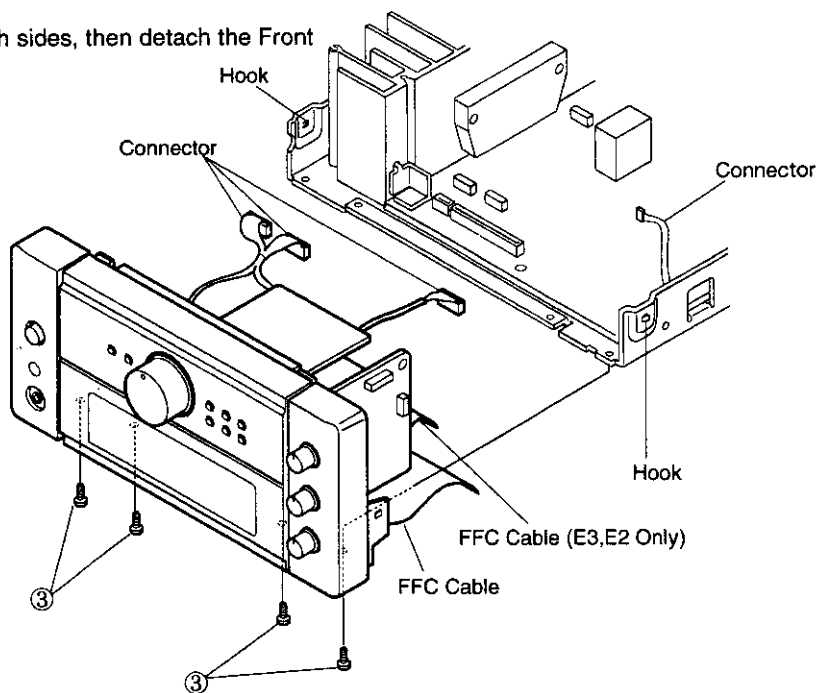

### 3. Rear Panel

- (1) Remove the Cord Bush.
- (2) Remove 12 screws ④, then detach the Rear Panel.

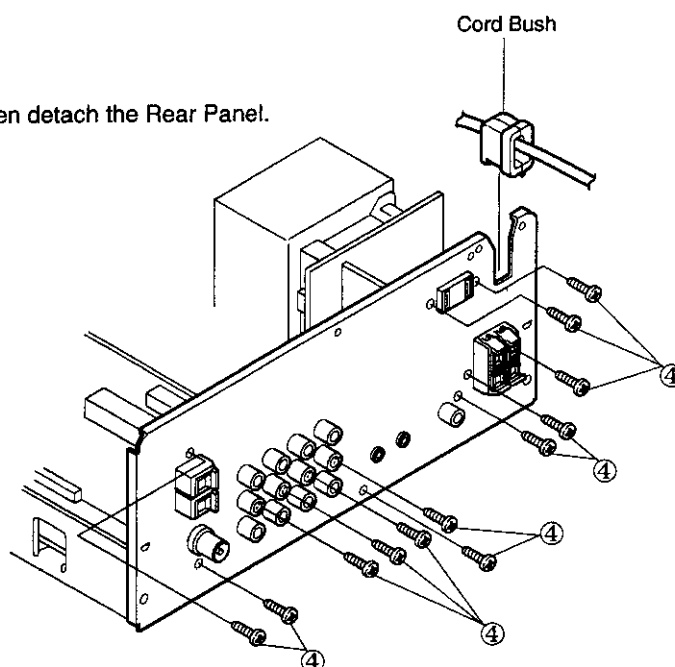

### 4. Main P.W.Board

- (1) Disconnect soldered wire.
- (2) Detach the Tuner P.W.B. from the Main P.W.B. (for Europe, U.K. models)
- (3) Remove 3 screws ⑤ fixing the Main P.W.B. from the top.
- (4) Remove 4 screws ⑥ fixing the Main P.W.B. from the bottom.
- (5) Release 2 P.W.B. holders, then detach the Main P.W.B.

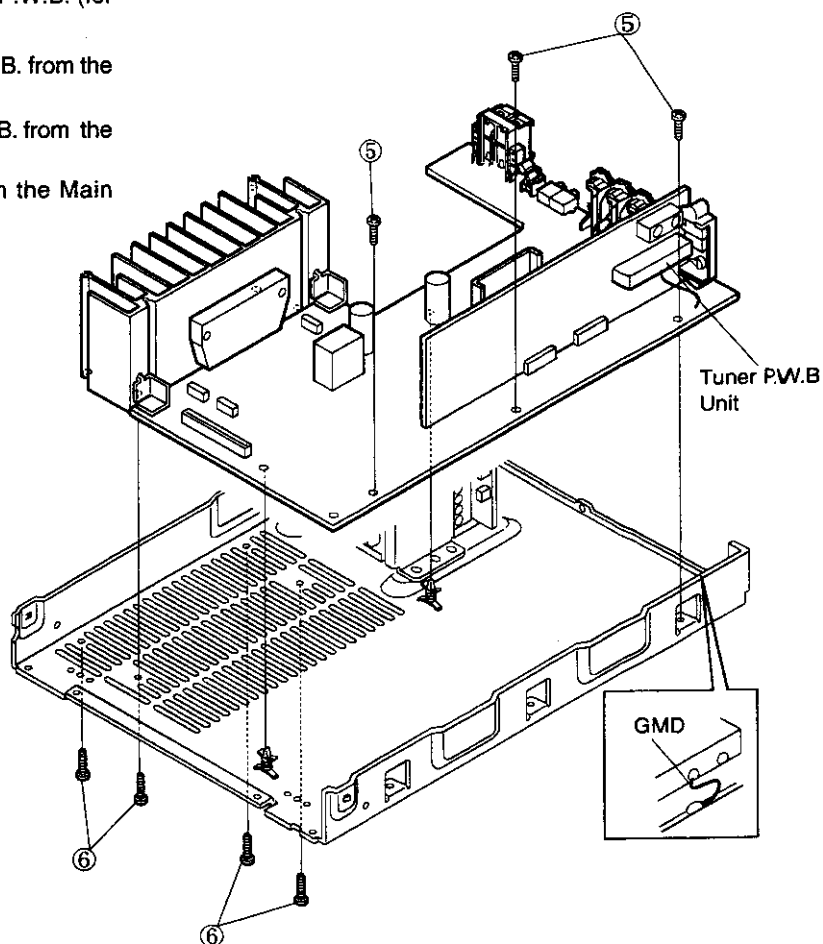

RECEIVER SECTION

BLOCK DIAGRAM

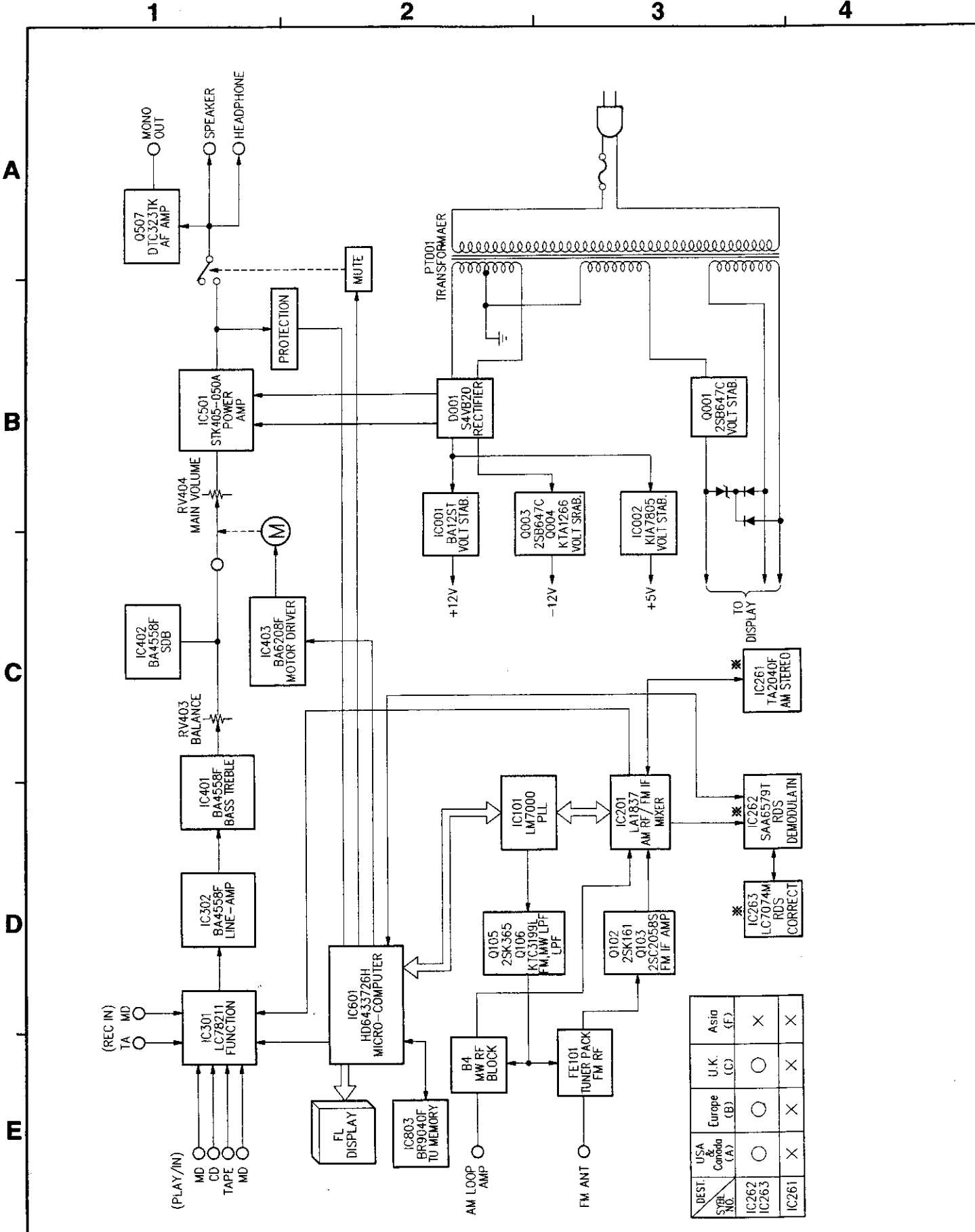

DEST. SYMBL. NO.	USA & Canada (A)	Europe (B)	U.K. (C)	Asia (F)
IC262	○	○	○	×
IC263	○	○	○	×
IC261	×	×	×	×

# BLOCK LEVEL DIAGRAM

## RECEIVER SECTION

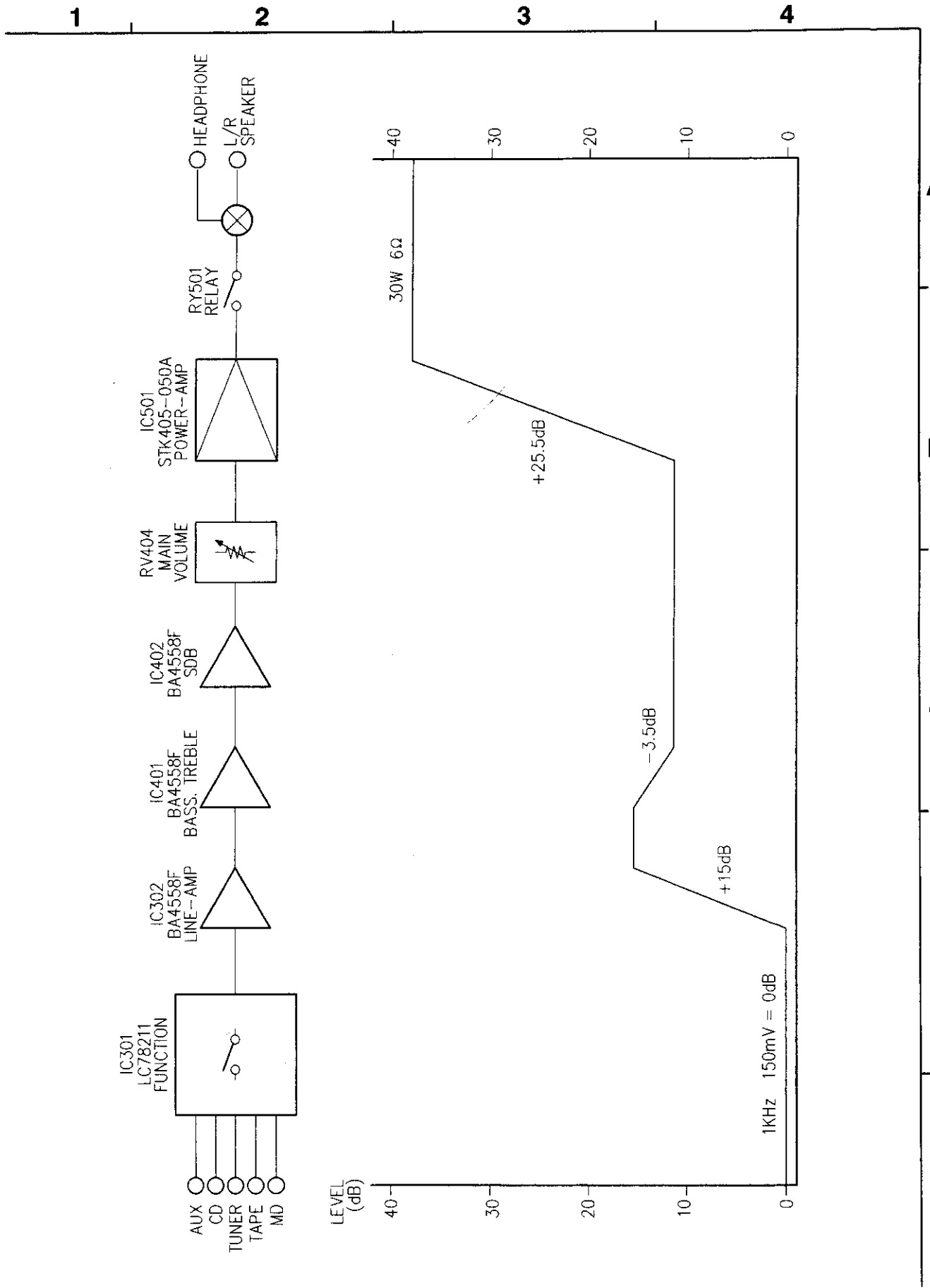

**RECEIVER SECTION**

**ADJUSTMENT**

TUNER ALIGNMENT(BAND BUTTON : FM, MONO/AUTO BUTTON : AUTO)

Step	Alignment Item	Tuning Frequency Setting	Input					Output		Adjustment		Remarks
			Instrument	Frequency	Input level	Modulation	Connection	Type	Connect to	Points	Adjust to	
1	FM DC BALANCE	83 MHz	FM S.G.	83 MHz	60 dBμ	1kHz 75kHz DEV	FM Antenna Terminal	DC Balance Meter	⊕PG201 ⊖PG201	T202	0 ± 30mV	Monaural Modulation
2	MUTING LEVEL	83 MHz	FM S.G.	83 MHz	22 dBμ	1kHz 75kHz DEV	FM Antenna Terminal	TUNED Lighting Cheek	Output Terminal	RT201	Input Level 22dBμ ± 4dB	Output signal appearing level

CONNECTION / ALIGNMENT POINTS (Component Side)

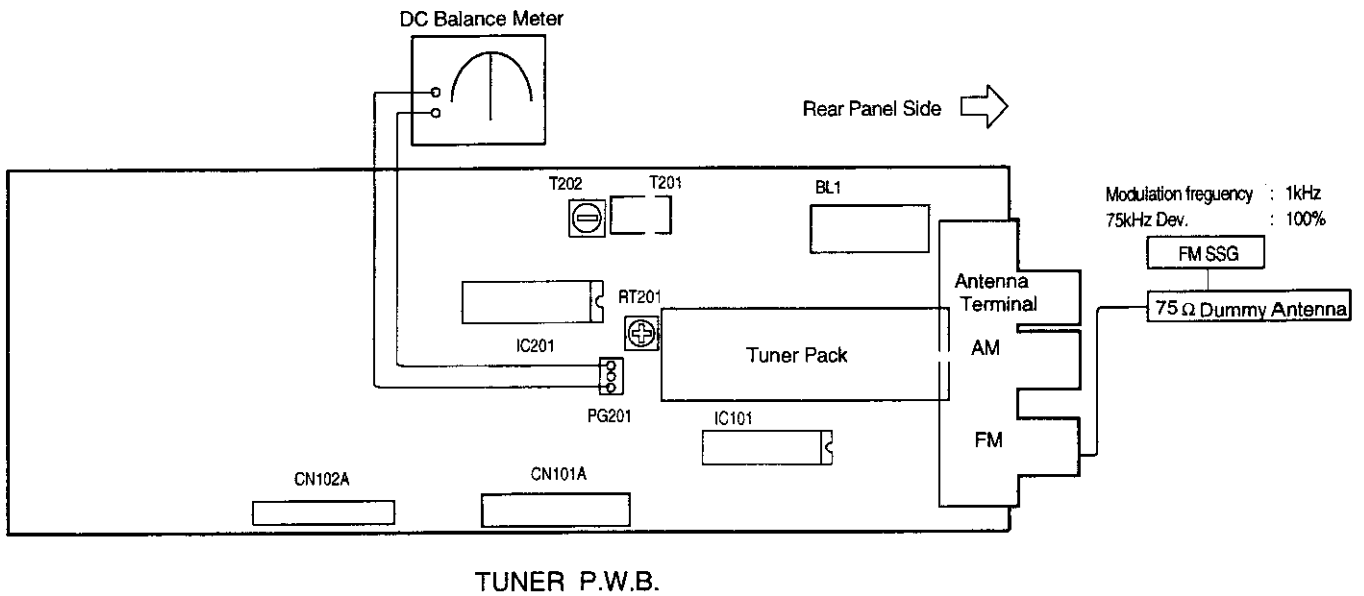



SEMICONDUCTORS

● IC's  
LM7000 (IC101)

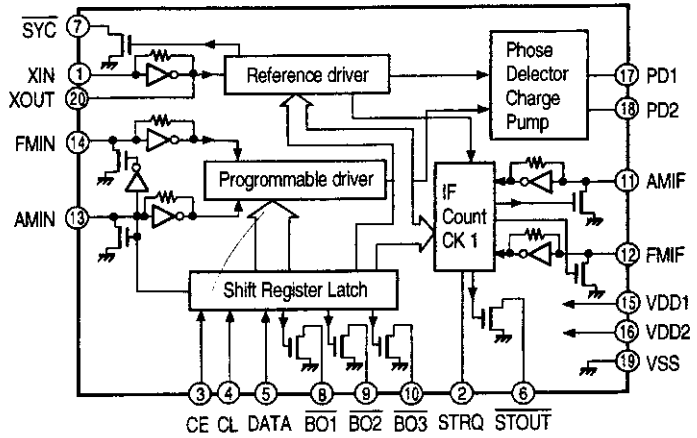
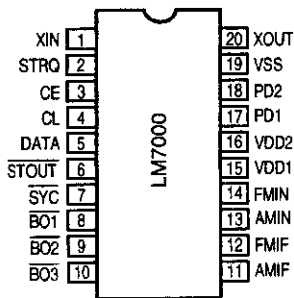
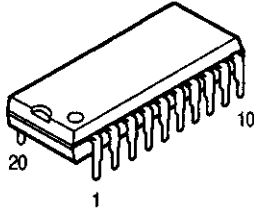

Pin Description

- SYC : Clock (400kHz) for the controller
- XIN, XOUT : X'tal oscillator (7.2MHz) with built-in
- FM IN, AM IN : feedback resistor
- CE, CL, DATA : Data input
- BO1, BO2, BO3 : Band data output. BO1 can be set as the time base output (8Hz)
- STRQ : IF counter request input
- STOUT : Auto research stop signal output
- VDD1, VDD2, VSS : Power supply (VDD2 is a back-up power supply)
- AMIF, FMIF : IF counter request input
- PD1, PD2 : Charge pump output

LA1837 (IC201)

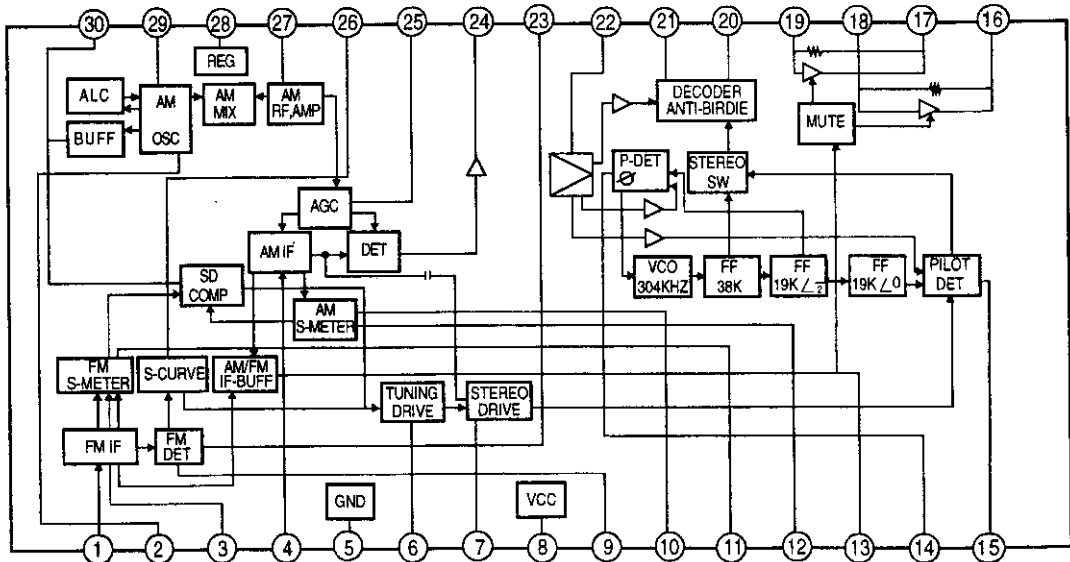
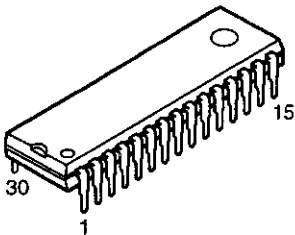

**RECEIVER SECTION**

**LC78211 (IC301)**

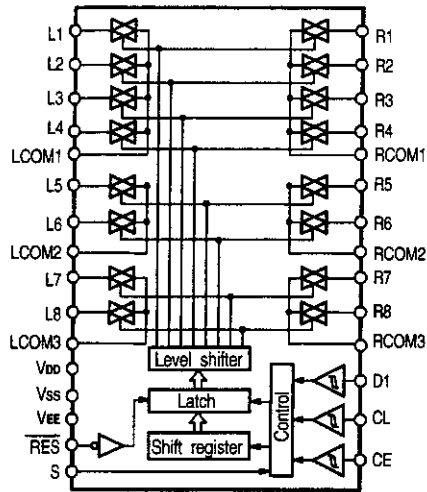
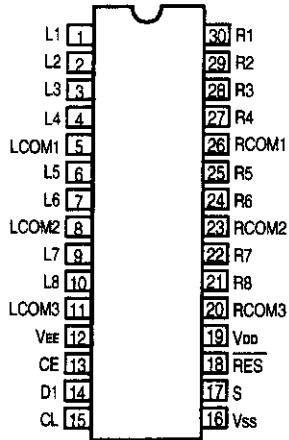

**STK405-050A (IC501)**

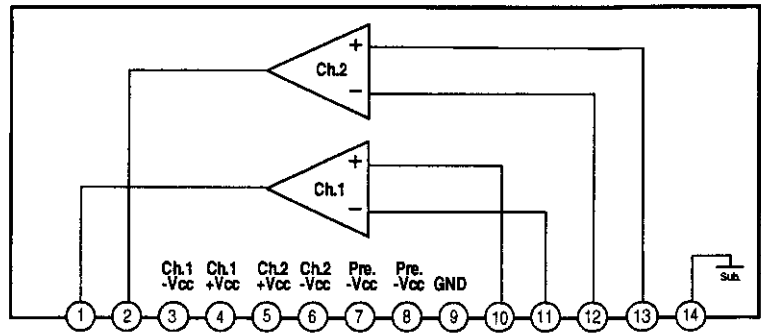
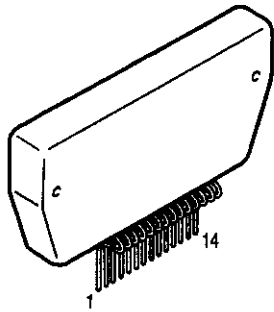

**TA2040AF (IC261)**

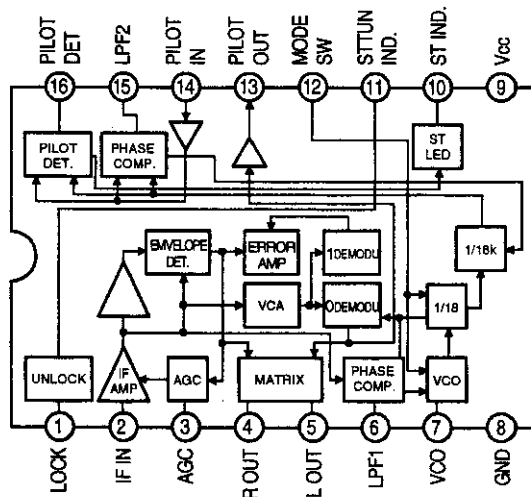
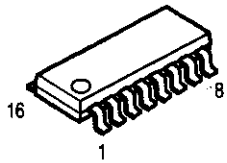

**RECEIVER SECTION**

**BR9040F (IC603)**

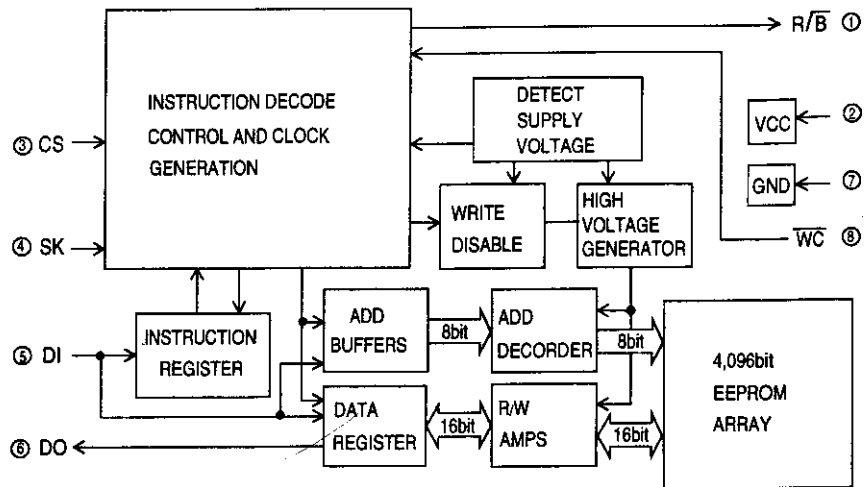
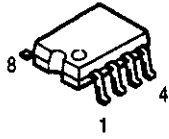

**BA12ST-V5 (IC001)**

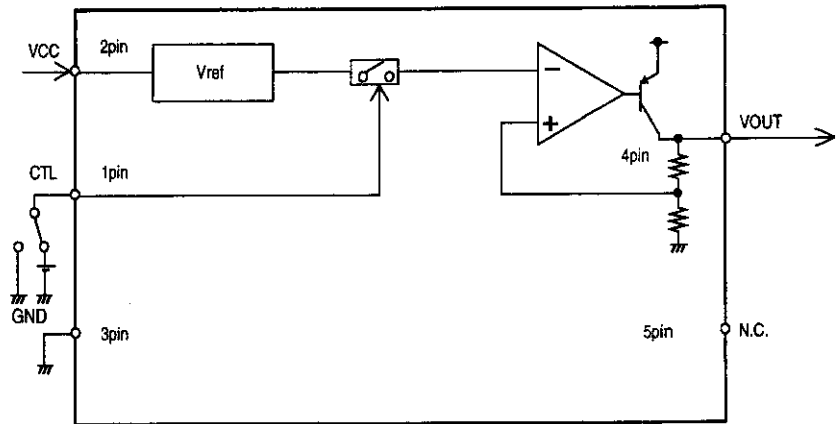
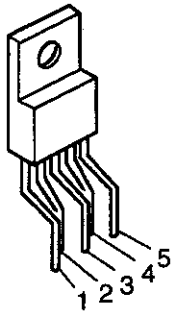

**BA6208F (IC403)**

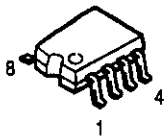

- 1: VCC
- 2: BOUT
- 3: GND
- 4: AOUT
- 5: BIN
- 6: VCT
- 7: GND
- 8: AIN

**BA4558F (IC302)**

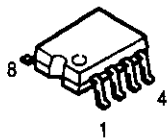

- 1: AOUT
- 2: AIN1
- 3: AIN2
- 4: VEE
- 5: BIN2
- 6: BIN1
- 7: BOUT
- 8: VCC

**KIA7045P (IC602)**

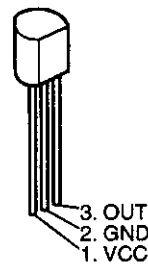

- 3: OUT
- 2: GND
- 1: VCC

**KIA7805PI (IC002)**

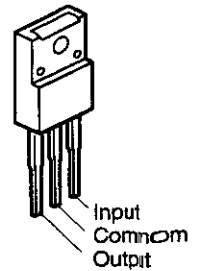

- Input
- Common
- Output

**●IC PROTECTOR**

**ICP-N5 (PR001,002,003,201)**



**RECEIVER SECTION**

**●TRANSISTOR**

**KTC3202  
HIT8050C**

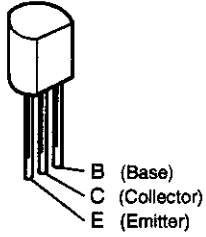

**2SB647 (C)**

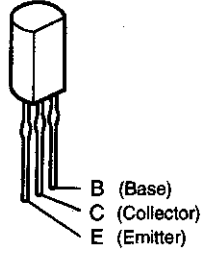

**KTC3199  
KTC3199L  
KTA1267**

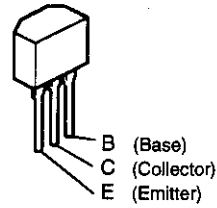

**2SK365 (BL/GR)**

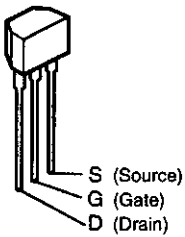

**2SK161**

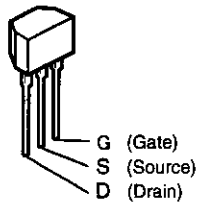

**DTA114EK  
DTC114EK  
DTA144EK  
DTC144EK  
DTC323EK**

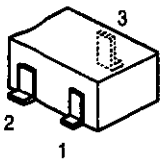

1: GND/Emitter  
2: IN/Base  
3: OUT/Emitter

**PNP Type**

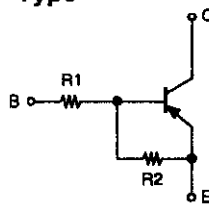

	R1	R2
DTA114EK	10 kohm	10 kohm
DTA144EK	47 kohm	47 kohm

**NPN Type**

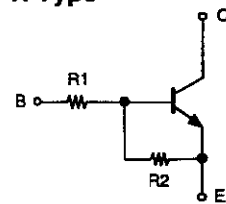

	R1	R2
DTC144EK	47 kohm	47 kohm
DTC323TK	2.2 kohm	—
DTC114EK	10 kohm	10 kohm

RECEIVER SECTION

●DIODE ( Including LED )

IN4531/1SS133

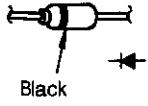

IN4002

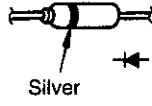

MTZ-J12C  
 MTZ-J5.6A  
 MTZ-J27A  
 MTZ-J6.2A  
 MTZ-J10A

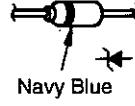

S4VB20

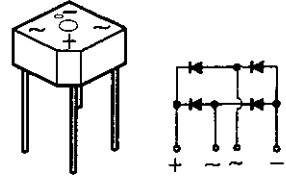

●REMOTE CONTROL SENSOR

RLL-20503PD-R15S

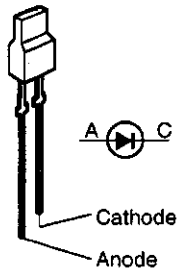

SPR-505MVW

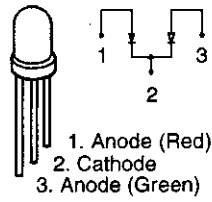

PIC-21043TH2

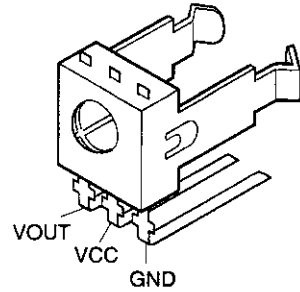

**RECEIVER SECTION**

● **FL DISPLAY 11BT27GK (FL601)**  
 (Parts No. : KDD00061)

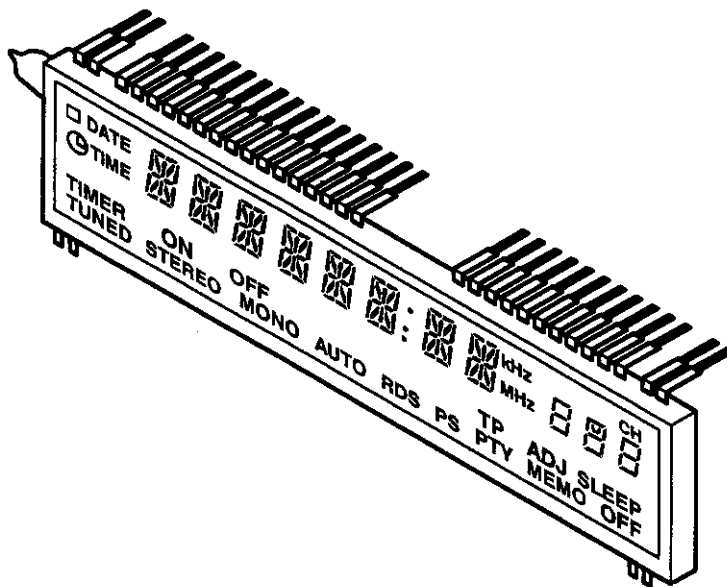

**Pin Connection**

Pin No.	1	2	3	4	5	6	7	8	9	10	11	12	13	14	15	16	17	18	19	20	21	22	23	24
Connection	F1	F1	NP	NP	P1	P2	P3	P4	P5	P6	P7	P8	P9	P10	P11	P12	P13	P14	P15	P16	NX	NX	NX	NX

Pin No.	25	26	27	28	29	30	31	32	33	34	35	36	37	38	39	40	41	42	43	44	45
Connection	NX	NX	NX	NX	NX	NX	11G	10G	9G	8G	7G	6G	5G	4G	3G	2G	1G	NP	NP	F2	F2

- NOTE
- 1) F1,F2 ..... Filament
  - 2) NP..... No Pin
  - 3) NC..... No Extension Pin
  - 4) DL ..... Datum Line
  - 5) 1G-11G..... Grid
  - 6) Visible Angle (Min) = 33° (Upper), 25° (Lower)

Grid Partition

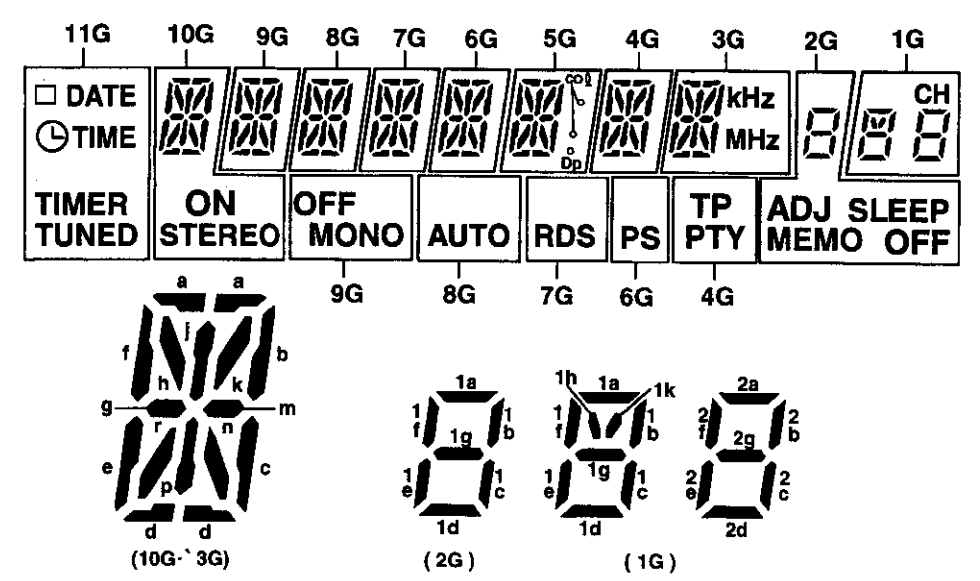

Anode Connection

	11G	10G	9G	8G	7G	6G	5G	4G	3G	2G	1G
P1	<input type="checkbox"/>	a	a	a	a	a	a	a	a	1a	1a
P2	⌚	b	b	b	b	b	b	b	b	1b	1b
P3	DATE	c	c	c	c	c	c	c	c	1c	1c
P4	TIME	d	d	d	d	d	d	d	d	1d	1d
P5	TIMER	e	e	e	e	e	e	e	e	1e	1e
P6	TUNED	f	f	f	f	f	f	f	f	1f	1f
P7	-	g	g	g	g	g	g	g	g	1g	1g
P8	-	h	h	h	h	h	h	h	h	ADJ	1h,1k
P9	-	j	j	j	j	j	j	j	j	MEMO	2a
P10	-	k	k	k	k	k	k	k	k	SLEEP	2b
P11	-	m	m	m	m	m	m	m	m	OFF	2c
P12	-	n	n	n	n	n	n	n	n	-	2d
P13	-	p	p	p	p	p	p	p	p	-	2e
P14	-	r	r	r	r	r	r	r	r	-	2f
P15	-	ON	OFF	AUTO	RDS	PS	col	TP	kHz	-	2g
P16	-	STEREO	MONO	-	-	-	Dp	PTY	MHz	-	CH

RECEIVER SECTION

MICROPROCESSOR DOCUMENTATION

HD6433726H (IC601)

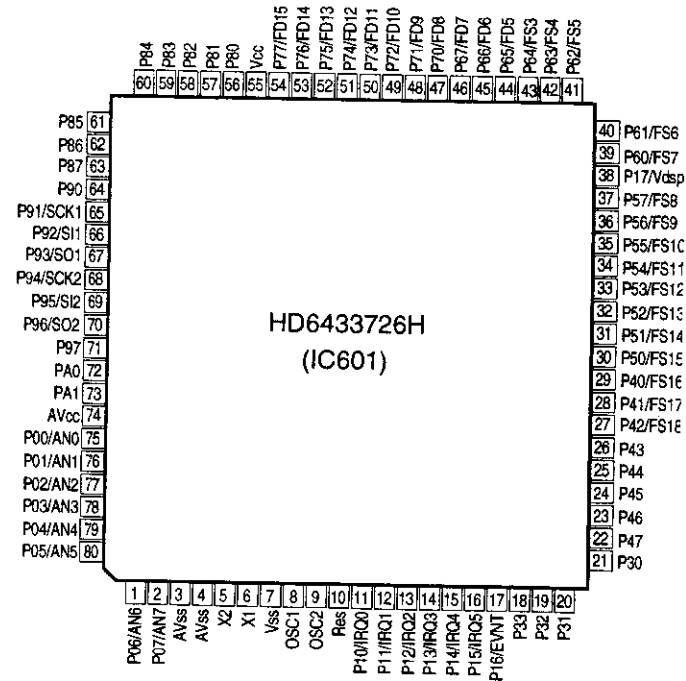
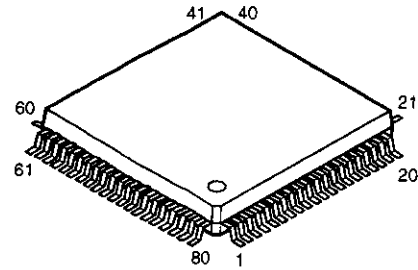

1. Overview

The functions of this microcomputer are made up of the following four pillars.

a. Tuner functions

These function perform the required control for the reception of FM and AM broadcasts.

b. Auto functions

Positioned at the heart of the system stereo, the auto functions perform serial communications with other components [such as the Deck (UDR-F10), and (UDCM-F10) ] to provide overall control.

These functions decode the signals from the remote control and send them to each component of the system. These functions perform two types of timer operations, "everyday and sleep."

c. Timer functions

Counts the clock of the 12-hour display.

Provides 2 types of timer operation : once and sleep.

d. Display Function

Outputs the control signal of the FLD.

**NOTE1** When buttons "STANDBY" and "MEMORY" are pressed simultaneously and the power or is inserted into the power outlet , the frequencies used for the tracking adjustment will automatically be registered in the preset memory as indicated below.

Use this information for tuning and other procedures

	P1	P2	P3	P4	P5
AM (kHz)	520	600	1000	1400	1710
	P11	P12	P13	P14	P15
FM (MHz)	87.5	89.0	98.0	100.1	108.0

\* P6 through P10 and P21 through P40 are AM 520 kHz, and P16 through P20 are FM 87.5 MHz.

**NOTE2** Depressing both the MEORY and BAND buttons while plugging the power cord into the power outlet serves to initialize the current time setting and the contents of the timer and preset memory.

2. Receiving Band Table

Band	Receiving frequency	Local oscillator frequency	IF	Frequency division ratio	Comparison frequency	Step frequency	Other
FM	87.5 ~ 108.0MHz	98.2 ~ 118.7MHz	10.7MHz	1	25kHz	100kHz	STEREO
AM	520 ~ 1710kHz	970 ~ 2160kHz	450kHz	—	10kHz	10kHz	

3. Signals sent to the LM7000 Programmable Divider

a. Signals to the programmable divider are sent from 3 sources: CE OUT, CLOCK OUT, and DATA OUT.

b. The programmable divider takes in DATA at CLOCK  $\downarrow$ , when CE equals 1.

c. The data is a 24-bit serial signal which is taken in to the programmable divider from the LSB. (At the AM setting, D0 through D3 are ignored, so that D4 becomes the LSB.)

d. The data is made up of the number of frequency divisions data, the band data, and the comparison frequency data. (See diagram below.)

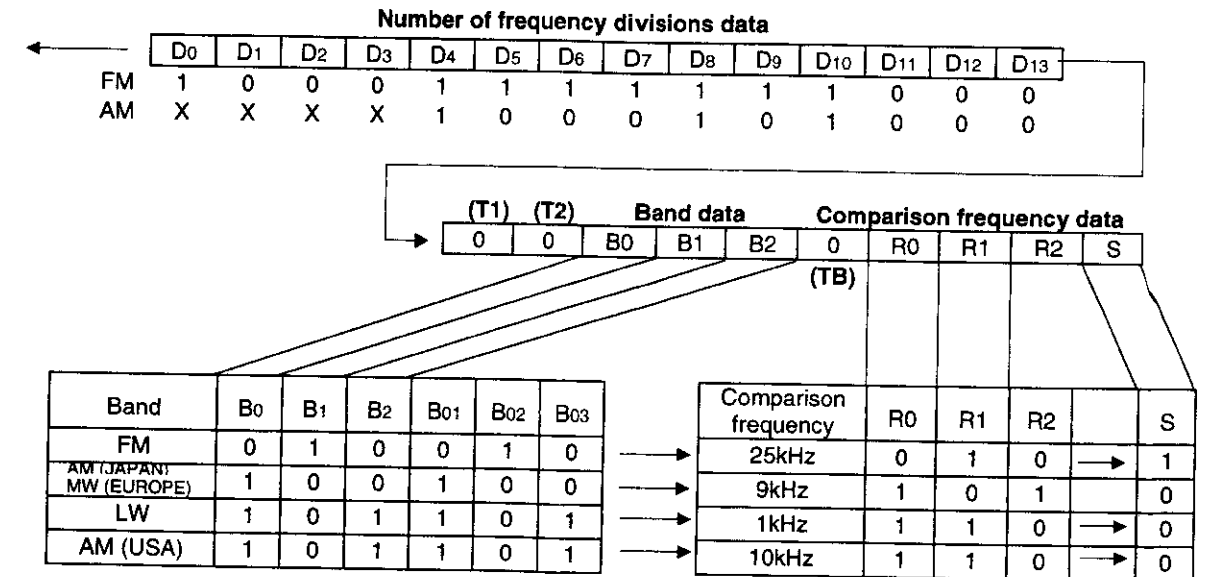

e. Timing for sending  
a = 2.5 μsec

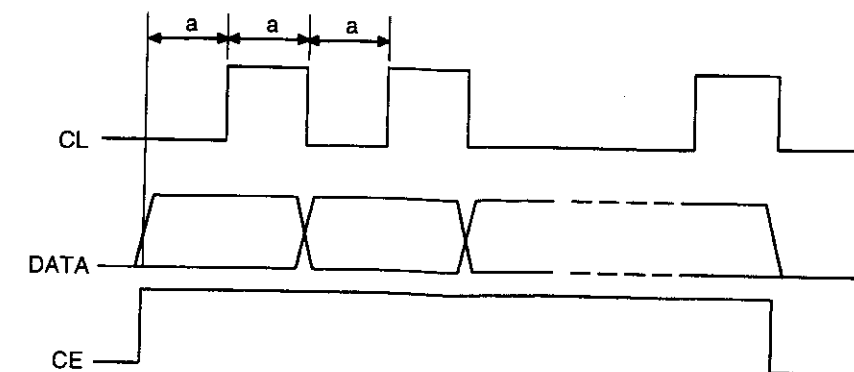



RECEIVER SECTION

HD6433726A76H Terminal Function

Pin No.	Symbol	Port Name	I/O	INI	ACT	Function
1	AM Stereo	P60/AN6	I	-	L	AM stereo signal detection.
2	Tuned In	P07/AN7	I	L	H	- FM/AM tuning signal input.
3	GND	AVss	-	-	-	Analog ground.
4	GND	Test	-	-	-	
5	Sub Xtal	X2	O	-	-	Sub Xtal drive.
6	Sub Xtal	X1	I	-	-	Sub Xtal input.
7	Vss	Vss	-	-	-	Ground.
8	OSC1	OSC1	O	-	-	8.38 MHz Xtal out.
9	OSC2	OSC2	I	-	-	8.38 MHz Xtal in.
10	Reset	Res	I	-	L	Reset input.
11	Remocon	P10/IRQ0	I	-	L	Remote control signal in.
12	50/60	P11/IRQ1	I	-	L	50/60 Hz AC input.
13	Protect	P12/IRQ2	I	-	L	Overcurrent detection signal input.
14	RDS Start	P13/IRQ3	I	-	L	RDS signal start detection.
15	RXD	P14/IRQ4	I	-	L	Denon Bus data input.
16	Mute	P15/IRQ5	O	H	L	Speaker relay off.
17	GND	P16/EVNT	I	-	-	Not used.
18	N.C.	P33	O	L	L	No connection.
19	RT Gr LED	P32	O	L	H	RT green LED.
20	TA Gr LED	P31	O	L	H	TA green LED.
21	PTY Gr LED	P30	O	L	H	PTY green LED.
22	RT Rd LED	P47	O	L	H	RT red LED.
23	TA Rd LED	P46	O	L	H	TA red LED.
24	PTY Rd LED	P45	O	L	H	PTY red LED.
25	Diode 1	P44	I	-	H	Setting return input 1.
26	Diode 2	P43	I	-	H	Setting return input 2.
27	Seg 1	P42/FS18	O	L	H	Segment 16 output.
28	Seg 2	P41/FS17	O	L	H	Segment 15 output.
29	Seg 3	P40/FS16	O	L	H	Segment 14 output.
30	Seg 4	P50/FS15	O	L	H	Segment 13 output.
31	Seg 5	P51/FS14	O	L	H	Segment 12 output.
32	Seg 6	P52/FS13	O	L	H	Segment 11 output.
33	Seg 7	P53/FS12	O	L	H	Segment 10 output.
34	Seg 8	P54/FS11	O	L	H	Segment 9 output.
35	Seg 9	P55/FS10	O	L	H	Segment 8 output.
36	Seg 10	P56/FS9	O	L	H	Segment 7 output.
37	Seg 11	P57/FS8	O	L	H	Segment 6 output.
38	Vdsp	P17/Vdsp	-	-	-	High B voltage.
39	Seg 12	P60/FS7	O	L	H	Segment 5 output.
40	Seg 13	P61/FS6	O	L	H	Segment 4 output.
41	Seg 14	P62/FS5	O	L	H	Segment 4 output.
42	Seg 15	P63/FS4	O	L	H	Segment 4 output.
43	Seg 16	P64/FS3	O	L	H	Segment 4 output.
44	Dig 11	P65/FD5	O	L	H	Digit 11 output.
45	Dig 10	P66/FD6	O	L	H	Digit 10 output.
46	Dig 9	P67/FD7	O	L	H	Digit 9 output.
47	Dig 8	P70/FD7	O	L	H	Digit 8 output.
48	Dig 7	P71/FD7	O	L	H	Digit 7 output.
49	Dig 6	P72/FD7	O	L	H	Digit 6 output.
50	Dig 5	P73/FD7	O	L	H	Digit 5 output.

Pin No.	Symbol	Port Name	I/O	INI	ACT	Function
51	Dig 4	P74/FD7	O	L	H	Digit 4 output.
52	Dig 3	P75/FD7	O	L	H	Digit 3 output.
53	Dig 2	P76/FD7	O	L	H	Digit 2 output.
54	Dig 1	P77/FD7	O	L	H	Digit 1 output.
55	Vcc	Vcc	-	-	-	5V.
56	Volume Dwn	P80	O	H	H	Master volume down.
57	Volume Up	P81	O	H	H	Master volume up.
58	Power	P82	O	L	L	Amplifier circuit power on.
59	Tuner Mute	P83	O	H	L	Tuner audio mute.
60	Auto/Mono	P84	O	H	-	FM Auto/Mono setting.
61	Ant Sns	P85	O	L	H	Antenna sensitivity reduction.
62	SDB	P86	O	L	H	Super Dynamic Bass.
63	Sel EEROM	P87	O	L	H	Select SCI to EEROM.
64	PLL CE	P90	O	L	H	PLL serial data selection output.
65	Bus Clock	P91/SCK1	O	H	-	Denon Bus clock.
66	Bus Data In	P92/SI1	I	-	-	Denon Bus data input.
67	Bus Data Out	P93/SO1	O	H	-	Denon Bus data output.
68	RDS Clock	P97/SCK2	O	H	-	RDS data fetch clock input, PLL control clock output, LC7821 clock output.
69	RDS Data	P95/SI2	I	H	-	RDS serial data input.
70	PLL Data	P96/SO2	O	H	-	PLL serial data output, LC7821 serial data output.
71	RDS Res	P97	O	H	L	LC7070 reset output.
72	PLL STRQ	PA0	O	L	H	IF count operation request output.
73	LC7821CE	PA1	O	L	H	LC7821 chip enable.
74	AVcc	AVcc	-	-	-	Analog 5 V power supply.
75	Key AD0	P00/AN0	I	-	-	Analog key input 1.
76	Key AD1	P01/AN1	I	-	-	Analog key input 1.
77	PWB Test	P02/AN2	I	-	-	Board check at 5 V.
78	Stereo In	P03/AN3	I	-	L	FM stereo demodulation detection.
79	Signal In	P04/AN4	I	-	L	RF signal detection signal input.
80	Stop In	P05/AN5	I	-	L	IF count tuning detection.



RECEIVER SECTION

1 2 3 4 5 6 7 8

Pattern Side

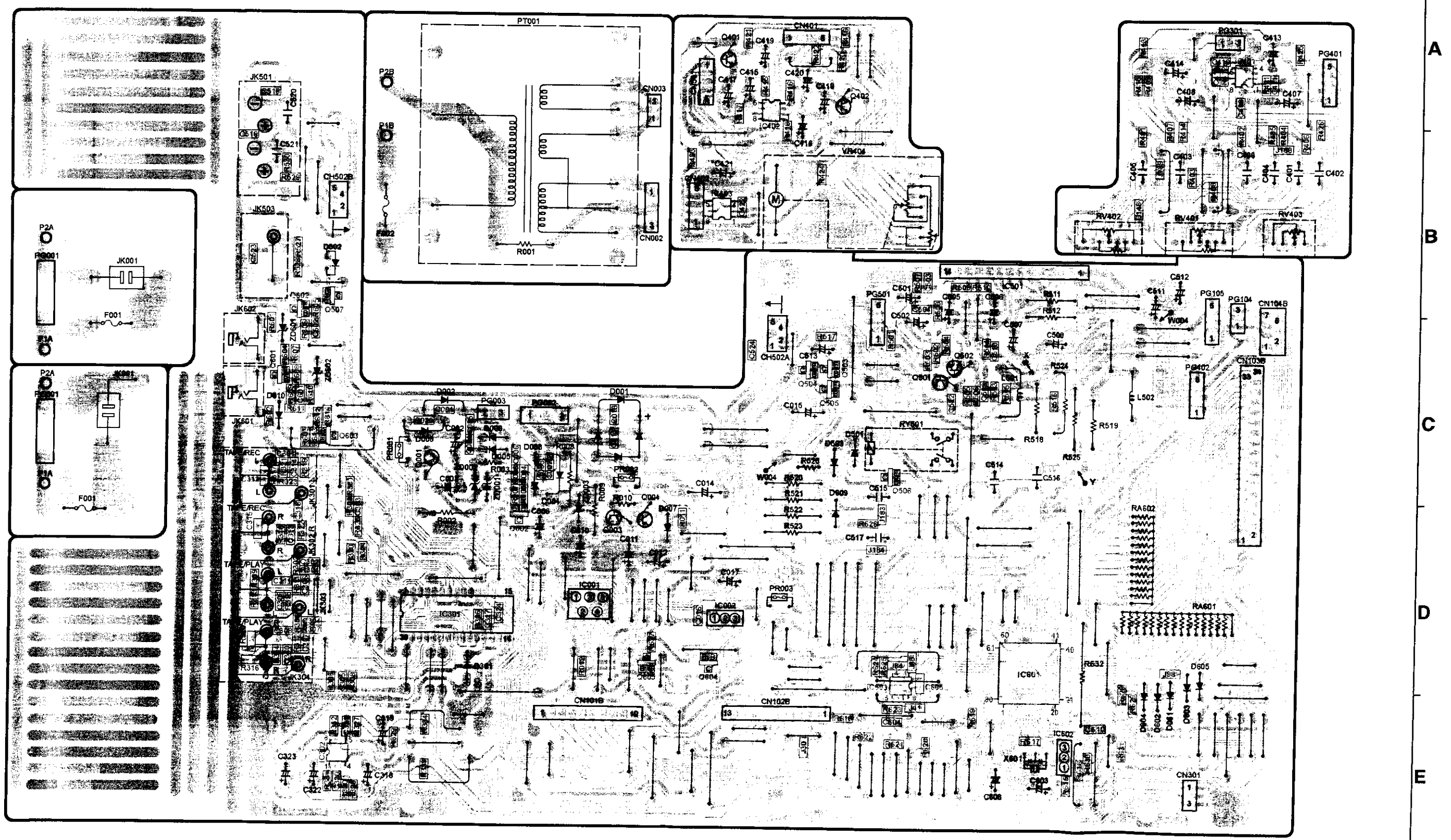

A

B

C

D

E

1 2 3 4 5 6 7 8

TUNER UNIT ASS'Y

Component Side

A

B

C

D

E

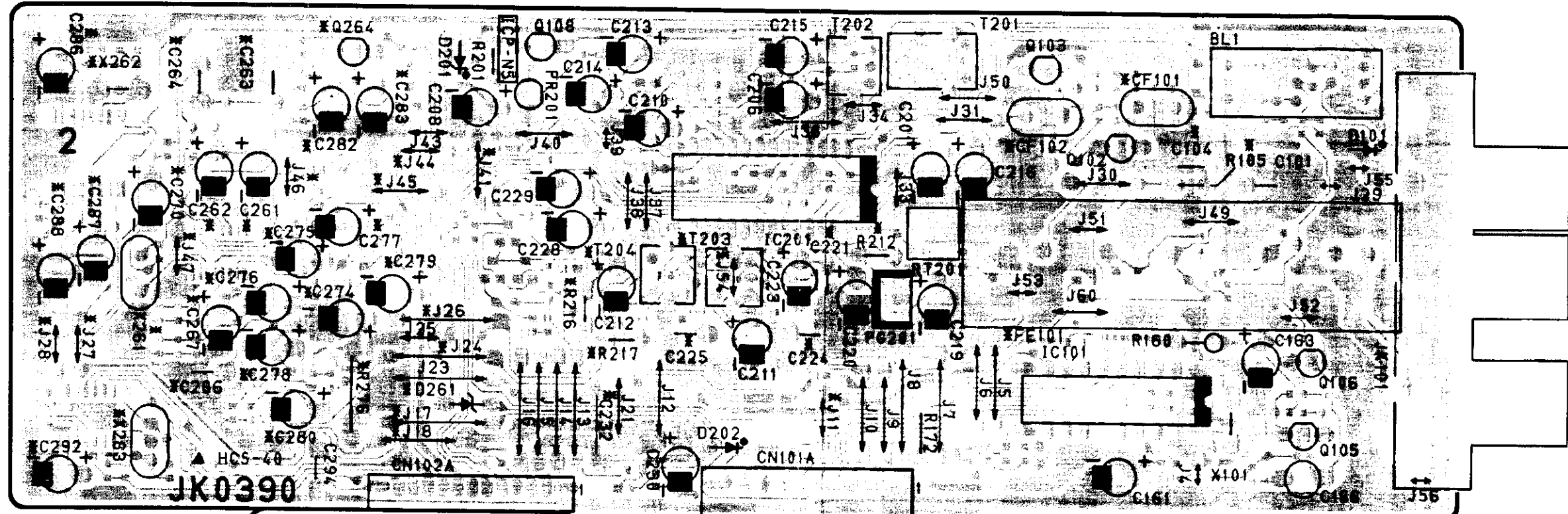

JK0390

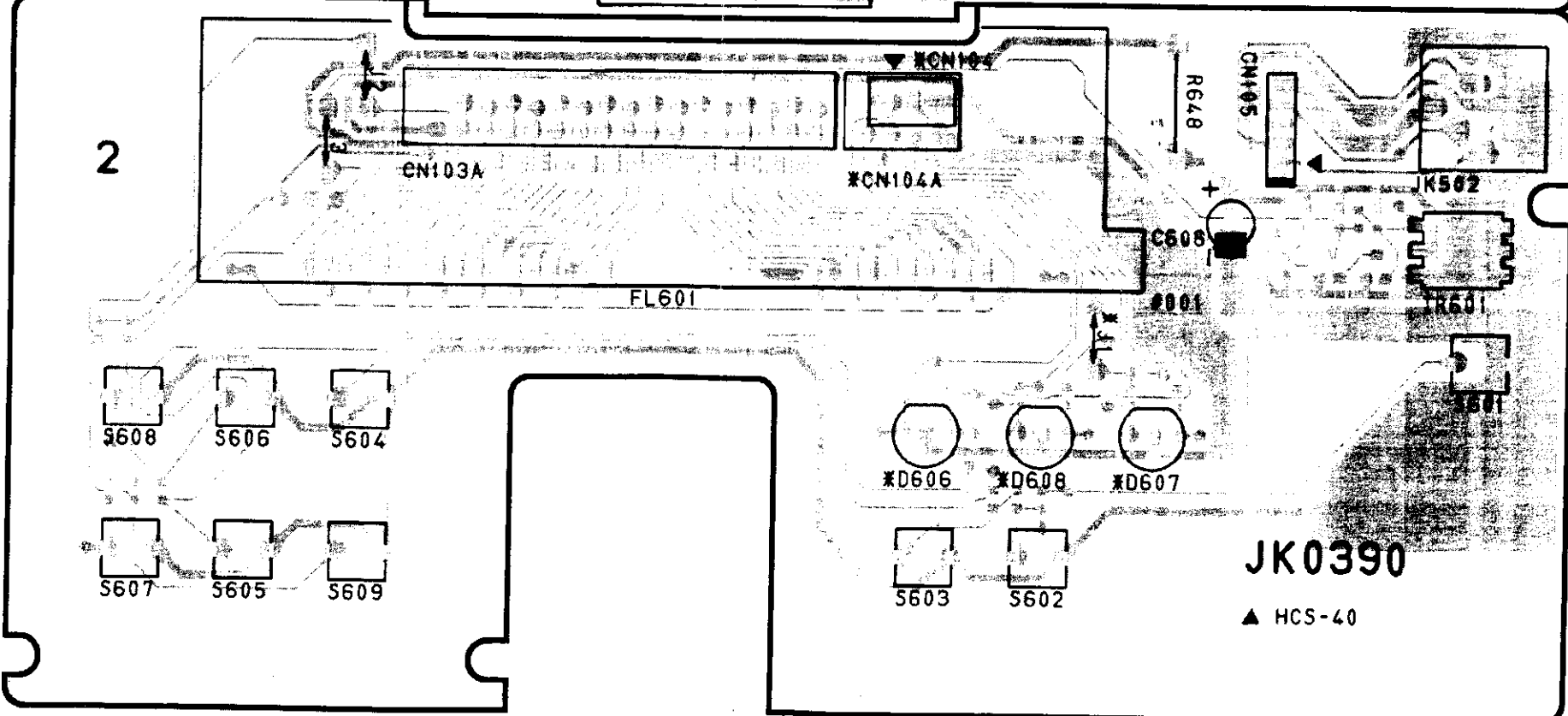

JK0390

▲ HCS-40

RECEIVER SECTION

1 2 3 4 5 6 7 8

Pattern Side

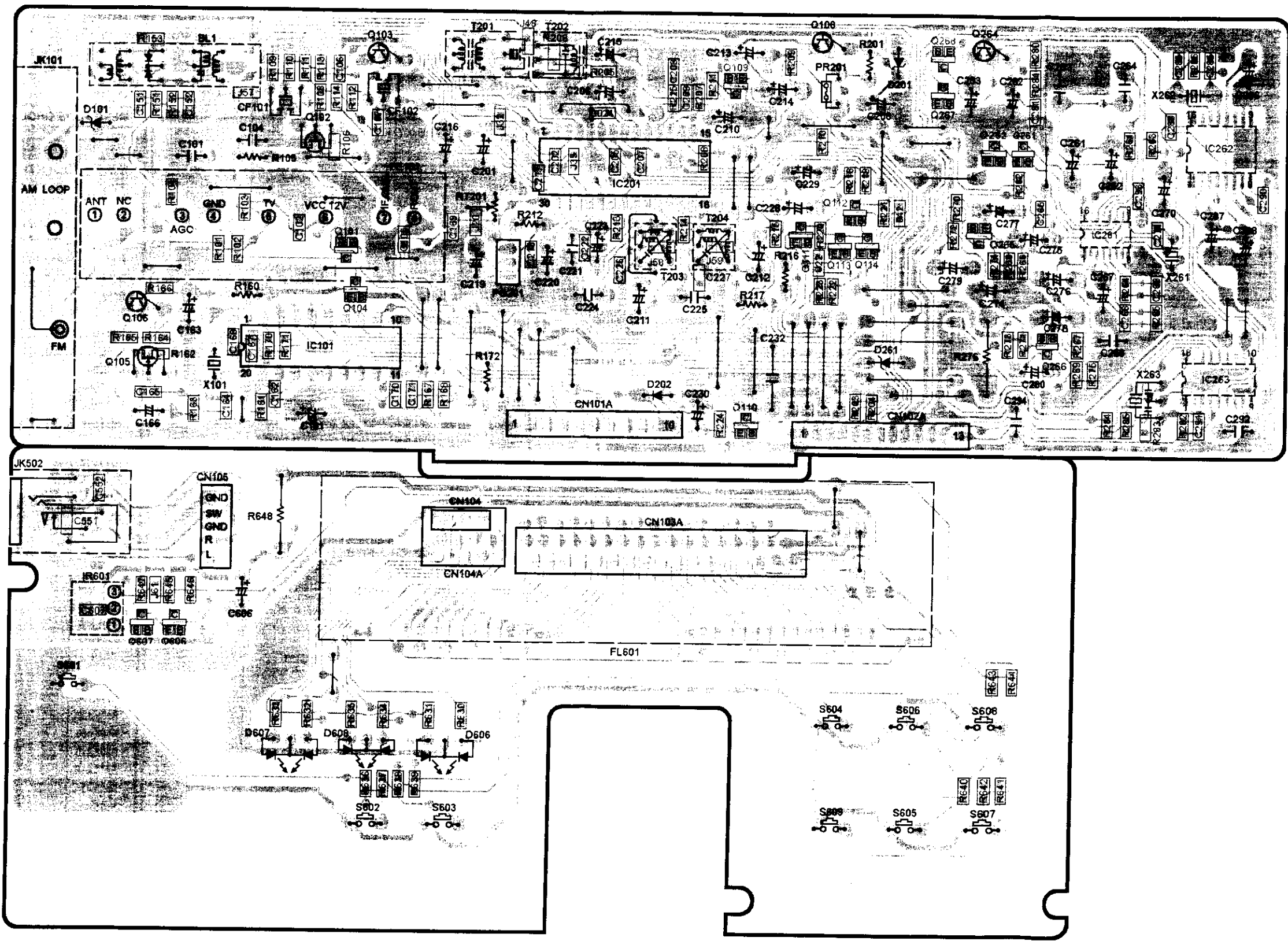

A  
B  
C  
D  
E



RECEIVER SECTION

NOTE FOR PARTS LIST

- Part indicated with the mark "⊙" are not always in stock and possibly to take a long period of time for supplying, or in some case supplying of part may be refused.
- When ordering of part, clearly indicate "1" and "I" (i) to avoid mis-supplying.
- Ordering part without stating its part number can not be supplied.
- Part indicated with the mark "★" is not illustrated in the exploded view.
- Not including Carbon Film ±5%, 1/4W Type in the P.W.Board parts list. (Refer to the Schematic Diagram for those parts.)

WARNING:

Parts marked with this symbol  $\Delta$  have critical characteristics. Use ONLY replacement parts recommended by the manufacturer.

● Resistors

Ex.: RN 14K 2E 182 G FR  
 Type Shape Power Resist- Allowable FR Others  
 and- ance error Others  
 performance

RD : Carbon	2B : 1/8W	F : ±1%	P : Pulse-resistant type
RC : Composition	2E : 1/4W	G : ±2%	NL : Low noise type
RS : Metal oxide film	2H : 1/2W	J : ±5%	NB : Non-burning type
RW : Winding	3A : 1W	K : ±10%	FR : Fuse-resistor
RN : Metal film	3D : 2W	M : ±20%	F : Lead wire forming
RK : Metal mixture	3F : 3W		
	3H : 5W		

\* Resistance

1 8 2 ⇒ 1800 ohm = 1.8 kohm  
 Indicates number of zeros after effective number.  
 2-digit effective number.

• Units: ohm

1 8 2 ⇒ 1.2 ohm  
 1-digit effective number.  
 2-digit effective number, decimal point indicated by R.

• Units: ohm

● Capacitors

Ex.: CE 04W 1H 2R2 M BP  
 Type Shape Dielectric Capacity Allowable M BP  
 and- strength Others  
 performance

CE : Aluminum foil electrolytic	0J : 6.3V	F : ±1%	HS : High stability type
CA : Aluminum solid electrolytic	1A : 10V	G : ±2%	BP : Non-polar type
CS : Tantalum electrolytic	1C : 16V	J : ±5%	HR : Ripple-resistant type
CQ : Film	1E : 25V	K : ±10%	DL : For charge and discharge
CK : Ceramic	1V : 35V	M : ±20%	HF : For assuring high frequency
CC : Ceramic	1H : 50V	Z : +80%	U : UL part
CP : Oil	2A : 100V	-20%	C : CSA part
CM : Mica	2B : 125V	P : +100%	W : UL-CSA type
CF : Metallized	2C : 160V	-0%	F : Lead wire forming
CH : Metallized	2D : 200V	C : ±0.25pF	
	2E : 250V	D : ±0.5pF	
	2H : 500V	= : Others	
	2J : 630V		

\* Capacity (electrolyte only)

2 2 2 ⇒ 2200μF  
 Indicates number of zeros after effective number.  
 2-digit effective number.

• Units: μF.

2 R 2 ⇒ 2.2μF  
 1-digit effective number.  
 2-digit effective number, decimal point indicated by R.

• Units: μF.

\* Capacity (except electrolyte)

2 2 2 ⇒ 2200pF=0.0022μF  
 (More than 2) — Indicates number of zeros after effective number.  
 2-digit effective number.

• Units: μF.

2 2 1 ⇒ 220pF  
 (0 or 1) — Indicates number of zeros after effective number.  
 2-digit effective number.

• Units: pF.

• When the dielectric strength is indicated in AC, "AC" is included after the dielectric strength value.

PARTS LIST OF P.W.B. UNIT ASS'Y  
 MAIN UNIT ASS'Y

Ref. No.	Part No.	Part Name	Remarks	Ref. No.	Part No.	Part Name	Remarks
<b>SEMICONDUCTORS GROUP</b>							
IC001	9LC P045 13	IC BA12ST-5V		ZD001	276 0645 949	Zener diode MTZJ-27A	27V
IC002	9LC P024 11	IC KIA7805PI		ZD002	276 0643 996	Zener diode MTZJ-5.6A	5.6V
				ZD003	9L2 3481 93M	Zener diode MTZJ-12C	12V
IC301	9L2 3016 92W	IC LC78211		ZD601,602	276 0637 902	Zener diode MTZJ-6.2A	6.2V
IC302	263 0672 903	IC BA4558F					
IC401,402	263 0672 903	IC BA4558F					
IC403	263 0905 007	IC BA6208F					
IC601	9LC K076 01	IC HD6433726H					
IC602	9LC P007 12R	IC KIA7045P					
IC603	262 2071 004	IC BR9040F					
$\Delta$ PR001-033	LA3 500U 216	IC protector ICP-N5					
Q001	9L2 3286 25	Transistor 2SB647C		R001	242 0074 009	Composition 2.7Mohm 1/2W	RES SOLD 1/2W 2.7MΩ U.S.A./Canada models
Q002	273 0384 900	Transistor 2SC2412KT		R002	9LH 1133 71	Carbon film 3.3kohm 1/2W	
Q003	9L2 3286 25	Transistor 2SB647C		R003	241 2400 995	Carbon film 10kohm 1/6W	RD14B2E103J (5)
Q004	9LC A006 61R	Transistor KTA1267(GR)		R004-007		Carbon chip 10kohm	
Q401,402	9LC A006 71R	Transistor KTC3199(GR)		R008	241 0193 000	Carbon film 2.2kohm 1/2W	RD14B2H222J
Q501,502	9LC F009 91R	Transistor KTC3202(Y)		R009	241 2398 955	Carbon film 1kohm 1/4W	RD14B2E102J
Q503	273 0384 900	Transistor 2SC2412KT		R010	241 2401 978	Carbon film 22kohm 1/6W	RD14B2E223J (5)
Q504	271 0238 908	Transistor 2SA1037AK (Q/R)		R011		Carbon chip 8.2kohm	
Q505	273 0384 900	Transistor 2SC2412KT		R012		Carbon chip 22kohm	
Q506	269 0082 902	Transistor DTC114EK		R301,302		Carbon Chip 470ohm	
Q507	269 0066 902	Transistor DTC323TK		R303,304		Carbon chip 82kohm	
Q601	271 0238 908	Transistor 2SA1037AK (Q/R)		R305,306		Carbon chip 8.2kohm	
Q602,603	273 0384 900	Transistor 2SC2412KT		R307,308		Carbon chip 39kohm	
Q604	269 0055 900	Transistor DTA144E		R309,310		Carbon chip 5.6kohm	
Q605	269 0054 901	Transistor DTC144EK		R311,312		Carbon chip 47kohm	
D001	276 0338 007	Diode S4VB20		R313,314		Carbon chip 8.2kohm	
D002-004	9L2 3980 61T	Diode IN4002		R315,316		Carbon chip 39kohm	
D005-007	276 0401 002	Diode IN4531/ISS133		R317,318		Carbon chip 1Mohm	
D008	9L2 3980 61T	Diode IN4002		R319,320		Carbon Chip 470ohm	
D301	276 0401 002	Diode IN4531/ISS133		R321,322		Carbon chip 1Mohm	
D501	276 0401 002	Diode IN4531/ISS133		R323,324		Carbon Chip 470ohm	
D502	9L2 3973 14	LED RLL-20503PD-R15(S)		R325		Carbon chip 100kohm	
D503	276 0401 002	Diode IN4531/ISS133		R326		Carbon chip 680kohm	
D602	276 0401 002	Diode IN4531/ISS133	U.S.A./Canada/Asia models	R327,328		Carbon chip 100kohm	
D603	276 0401 002	Diode IN4531/ISS133	Except U.S.A./Canada model	R329,330		Carbon chip 1kohm	
D604	9L2 3980 61T	Diode IN4002	Asia model only	R331,332		Carbon chip 4.7kohm	
D605	276 0401 002	Diode IN4531/ISS133	Except Asia model	R333,334		Carbon chip 100kohm	
D609,610	276 0401 002	Diode IN4531/ISS133		R401,402		Carbon chip 24kohm	
				R403,404		Carbon Chip 220ohm	
				R405,406		Carbon chip 10kohm	
				R407,408		Carbon chip 22kohm	
				R409,410		Carbon chip 39kohm	
				R411,412		Carbon chip 1Mohm	
				R413,414		Carbon chip 1kohm	
				R415,416		Carbon Chip 330ohm	
				R417,418		Carbon chip 470kohm	
				R419,420		Carbon chip 56kohm	
				R421,422		Carbon chip 5.6kohm	
				R423-426		Carbon chip 10kohm	
				R501-504		Carbon chip 1kohm	

RECEIVER SECTION

Ref. No.	Part No.	Part Name	Remarks	Ref. No.	Part No.	Part Name	Remarks
R505,506		Carbon chip 10kohm		C301		Chip capacitor 0.01μF/50V	
R507,508		Carbon chip 56kohm		C302,303		Chip capacitor 680pF/50V	
R509,510		Carbon chip 2.7kohm		C304-307		Chip capacitor 220pF/50V	
R511,512	9L1 1106 21	Fuse resistor 100ohm		C308		Chip capacitor 0.01μF/50V	
R513,514		Carbon chip 56kohm		C309,310		Chip capacitor 220pF/50V	
R515-517		Carbon chip 22kohm		C311		Chip capacitor 0.01μF/50V	
R518-519	241 2393 989	Carbon film 10ohm 1/4W	RD14B2E100J	C312-315		Chip capacitor 220pF/50V	
R520-523	241 0137 008	Carbon film 10ohm 1/2W	RD14B2H100J	C316		Chip capacitor 0.01μF/50V	
Δ R524,525	241 0035 002	Metal oxide 33ohm 1W	RS14B3A231JNB	C317		Chip capacitor 0.022μF/50V	
Δ R526	241 2322 015	Carbon film 82ohm 1/4W (NB)	RD14B2E20JNBF	C318,319	254 4260 045	Electrolytic 1μF/50V	CE04W1H010M
R527		Carbon chip 10kohm		C320,321		Chip capacitor 100pF/50V	
R528		Carbon chip 2.2kohm		C322,323	254 4260 045	Electrolytic 1μF/50V	CE04W1H010M
R529,530		Carbon chip 22kohm		C324		Chip capacitor 0.022μF/50V	Asia model only
R601		Carbon Chip 100ohm		C401,402	255 1258 011	Mylar film 1800pF/50V	CQ93M1H182J
R602		Carbon Chip 220ohm		C403-406	255 1260 012	Mylar film 0.022μF/50V	CQ93M1H223J(B)
R603		Carbon chip 47kohm		C407,408	254 4260 045	Electrolytic 1μF/50V	CE04W1H010M
R604		Carbon chip 1kohm		C409-412		Chip capacitor 220pF/50V	
R605,606		Carbon chip 22kohm		C413,414	254 4260 087	Electrolytic 10μF/50V	CE04W1H100M
R607		Carbon chip 2.2kohm		C415,416	254 4260 016	Electrolytic 0.22μF/50V	CE04W1HR22M
R608,609		Carbon chip 22kohm		C417,418	254 4195 055	Electrolytic 0.15μF/50V	CE04W1HR15M
R610-612		Carbon chip 10kohm		C419,420	254 4256 033	Electrolytic 47μF/25V	CE04W1E470M
R613		Carbon chip 22kohm		C421	254 4260 087	Electrolytic 10μF/50V	CE04W1H100M
R614		Carbon chip 10kohm		C422		Chip capacitor 0.01μF/50V	
R615		Carbon Chip 470ohm		C501,502	254 4260 045	Electrolytic 1μF/50V	CE04W1H010M
R616		Carbon chip 10kohm		C503,504		Chip capacitor 470pF/50V	
R617		Carbon chip 1Mohm		C505,506	254 4260 087	Electrolytic 10μF/50V	CE04W1H100M
R618-620		Carbon chip 10kohm		C507,508	254 4261 028	Electrolytic 100μF/50V	CE04W1H101M
R621,622		Carbon chip 1kohm		C509,510		Chip capacitor 3.0pF	
R623-631		Carbon chip 10kohm		C511,512	254 4260 087	Electrolytic 10μF/50V	CE04W1H100M
R632	241 2398 955	Carbon film 1kohm 1/6W	RD14B2E102J (5)	C513	254 4250 042	Electrolytic 330μF/6.3V	CE04W0J331M
RV401,402	9LA Y001 88	Variable resistor 50kohm		C514-517	255 1084 007	Mylar film 0.1μF/50V(ECQ)	CQ93M1H104K ECQM
RV403	9LA Y003 91	Variable resistor 100kohm		C518,519		Chip capacitor 0.01μF/50V	Europe/J.K. models
RV404	9LA Y002 51	Motor volume resistor 100Kohm		C520,521		Mylar film 0.033μF/50V(AMZ)	Europe/J.K. models
<b>CAPACITORS GROUP</b>				C522		Chip capacitor 1000pF/50V	
C001		Chip capacitor 0.01μF/50V		C523,524		Chip capacitor 0.047μF/50V	Europe/J.K. models
C002	254 4261 028	Electrolytic 100μF/50V	CE04W1H101M	C601,602		Chip capacitor 1000pF/50V	
C003	254 4260 087	Electrolytic 10μF/50V	CE04W1H100M	C603	254 4260 993	Electrolytic 22μF/50V(SSL)	CE04W1H220M
C004-006		Chip capacitor 0.01μF/50V		C604,605		Chip capacitor 0.01μF/50V	
C007,008		Chip capacitor 0.022μF/50V		C608	254 4252 037	Electrolytic 100μF/10V(SME)	CE04W1A101M
C009	254 4261 028	Electrolytic 100μF/50V	CE04W1H101M	C609		Chip capacitor 1000pF/50V	
C010-012	254 4260 087	Electrolytic 10μF/50V	CE04W1H100M	C610		Chip capacitor 0.01μF/50V	
C013		Chip capacitor 0.01μF/50V		<b>OTHER PARTS GROUP</b>			
C014,015	254 4438 709	Electrolytic 4700μF/35V	CE04W1V472M	RY501	9L2 6413 21	SP relay 24V	1
C016		Chip capacitor 0.01μF/50V		X601	399 0243 903	Crystal CST 8.38 MTW	1
C017	254 4260 087	Electrolytic 10μF/50V	CE04W1H100M	CH502A,502B		5P Cable holder	2
C018		Chip capacitor 0.01μF/50V					
C020		Chip capacitor 0.01μF/50V					

RECEIVER SECTION

Ref. No.	Part No.	Part Name	Remarks	Q'ty	Ref. No.	Part No.	Part Name	Remarks	Q'ty
CN002		3P VH-boadin L=100		1	PG105		5P PH plug		1
CN003		3P MX-boadin L=80		1	PG301		3P MX pin post		1
CN101B		Pin header (9113B)		1	PG401		5P PH plug		1
CN102B		13P pin header		1	PG402		5P TXL pin post		1
CN103B	9LE D016 62	34P FFC connector		1	PG501		5P MX pin post		1
CN104B	9LE D007 72	7P FFC connector	Europe/U.K. models	1	#002	9L8 6914 10	Screw BH BT 3x10		2
CN301		3P MX-boadin		1	#003		Heat sink		1
CN401		5P PH boadin		1	#004		Shield plate		1
CN402		5P TXL-boadin L=75		1	#005		Shield plate (AUX)	Except U.S.A./Canada model	1
CN501		5P MX-boadin L=100		1	W001		1 Pin boadin connector L=150 (ORG)		1
E001-004	9L2 7292 52R	Fuse holder		4	W002		1 Pin boadin connector L=150 (GRY)		1
J030		Carbon Chip 0ohm		1	W003		UL wire L=50 (BLK)		1
J041		Carbon Chip 0ohm		1	W004		UL wire L=170 (BLK)		1
J084,085		Carbon Chip 0ohm		2	W502		5P ribbon wire L=225		1
J098		Carbon Chip 0ohm		1	9LJT07001		Main P.W.B. unit Ass'y	U.S.A./Canada models	1
J148		Carbon Chip 0ohm		1	9LJT07002		Main P.W.B. unit Ass'y	Europe model only	1
J183,184		Carbon Chip 0ohm		2	9LJT07003		Main P.W.B. unit Ass'y	U.K. model only	1
J188,189		Carbon Chip 0ohm		2	9LJT07006		Main P.W.B. unit Ass'y	Asia model only	1
Δ JK001	9LE P001 32	AC outlet (for EDISON)	U.S.A./Canada models	1					
Δ JK001	9LE P000 91	AC outlet (YKE1-0000)	Except U.S.A./Canada model	1					
JK301	9LE R003 92	3P US pin jack (WHT)		1					
JK302	9LE R003 91	3P US pin jack (RED)		1					
JK303	9LE R003 92	3P US pin jack (WHT)		1					
JK304	9LE R003 91	3P US pin jack (RED)		1					
JK501	9LE U000 86	4P SP terminal		1					
JK503	9LE R002 41	1P US pin jack		1					
JK601,602	9L2 6714 13	Mini jack (3.5)		2					
L501,502	9L2 2273 61	Audio trap coil		2					
N001		Style pin		1					
PG001		2P (4) VH pin post		1					
PG002		3P VH pin post		1					
PG003		3P MX pin post		1					
PG104		3P TXL pin post	U.S.A./Canada models	1					



RECEIVER SECTION

TUNER & DISPLAY UNIT ASS'Y

Ref. No.	Part No.	Part Name	Remarks
<b>SEMICONDUCTORS GROUP</b>			
IC101	262 0703 002	IC LM7000	
IC201	9LC P045 0 1	IC LA1837	
IC262	262 1701 906	IC SAA6579T	Except Asia model
IC263	9LC K044 7 1	IC LC7074M	Except Asia model
Δ PR201	268 0077 901	IC protector ICP-N5	
Q101	269 0082 902	Transistor DTC114EK	Europe/U.K. models
Q102	275 0051 006	Transistor 2SK161	
Q103	273 0434 902	Transistor 2SC2058S(Q)	
Q104	269 0083 901	Transistor DTA114EK	
Q105	275 0053 907	Transistor 2SK365 (BL/GR)	
Q106	9LA T012 44R	Transistor KTC3199L (GR)	
Q108	9L2 3190 52T	Transistor HIT8050C	
Q109	269 0082 902	Transistor DTC114EK	
Q110	269 0083 901	Transistor DTA114EK	
Q111-114	269 0066 902	Transistor DTC323TK	
Q606,607	273 0384 900	Transistor 2SC2412KT	
D101	276 0401 905	Diode IN4531/ISS133	
D201	9L2 3481 71M	Diode MTZJ - 10A	
D202	276 0401 905	Diode IN4531/ISS133	
D606	9LC H011 31F	Diode SPR-505MVW (RED-GREEN)	U.S.A./Canada models
D606-608	9LC H011 31F	Diode SPR-505MVW (RED-GREEN)	Europe/U.K. models
FL601	9LD D000 61	FL tube (FLD)	
<b>RESISTORS GROUP</b>			
R101		Carbon chip 1kohm	
R102		Carbon chip 150ohm	Europe/U.K. models
R103		Carbon chip 27kohm	Europe/U.K. models
R104		Carbon chip 22kohm	Europe/U.K. models
R105	241 2396 960	Carbon film 22ohm 1/6W	RD14B2E151J (5)
R106		Carbon chip 390ohm	Europe/U.K. models
R106		Carbon chip 1kohm	U.S.A./Canada/Asia models
R108		Carbon chip 330ohm	Except Asia model
R109		Carbon chip 330ohm	
R110		Carbon chip 220ohm	
R111		Carbon chip 4.7kohm	
R112		Carbon chip 330ohm	
R113		Carbon chip 390ohm	Europe/U.K. models
R113		Carbon chip 2.7kohm	U.S.A./Canada/Asia models
R114		Carbon chip 100ohm	

Ref. No.	Part No.	Part Name	Remarks
R151,152		Carbon chip 100kohm	
R153		Carbon chip 47kohm	
Δ R160	241 2377 947	Carbon film 100ohm 1/4W(NB)	RD14B2E101J(NBS)
R161		Carbon chip 1kohm	
R162		Carbon chip 220ohm	
R163		Carbon chip 2.2kohm	
R164		Carbon chip 220ohm	
R165		Carbon chip 470ohm	
R166		Carbon chip 22kohm	
R167,168		Carbon chip 220ohm	
R170,171		Carbon chip 10kohm	
R172	241 2400 995	Carbon film 10Kohm 1/6W	RD14B2E103J (5)
R201	241 2398 955	Carbon film 1Kohm 1/6W	RD14B2E102J (5)
R203,204		Carbon chip 10kohm	
R205		Carbon chip 100ohm	
R206,207		Carbon chip 4.7kohm	
R208		Carbon chip 10kohm	
R209		Carbon chip 30kohm	
R210,211		Carbon chip 4.7kohm	
R212	241 2400 953	Carbon film 6.8Kohm 1/6W	RD14B2E682J (5) U.S.A./Canada models
R212	241 2400 995	Carbon film 10Kohm 1/6W	RD14B2E103J (5) Except U.S.A./Canada model
R213		Carbon chip 8.2kohm	
R214,215		Carbon chip 3.3kohm	
R218,219		Carbon chip 1kohm	
R220,221		Carbon chip 220ohm	
R222,223		Carbon chip 1kohm	
R224		Carbon chip 5.6kohm	
R225		Carbon chip 51ohm	
R282		Carbon chip 10kohm	Except Asia model
R283		Carbon chip 1Mohm	Except Asia model
R284,285		Carbon chip 1kohm	Except Asia model
R286		Carbon chip 1Mohm	Except Asia model
R630		Carbon chip 330ohm	Except Asia model
R631		Carbon chip 220ohm	Except Asia model
R632		Carbon chip 330ohm	Europe/U.K. models
R633		Carbon chip 220ohm	Europe/U.K. models
R634		Carbon chip 330ohm	Europe/U.K. models
R635		Carbon chip 220ohm	Europe/U.K. models
R636		Carbon chip 680ohm	
R637		Carbon chip 390ohm	
R638		Carbon chip 270ohm	
R639		Carbon chip 180ohm	
R640		Carbon chip 150ohm	
R641		Carbon chip 180ohm	
R642		Carbon chip 150ohm	
R643,644		Carbon chip 1kohm	
R645		Carbon chip 22kohm	

Ref. No.	Part No.	Part Name	Remarks
R646		Carbon chip 100kohm	
R647		Carbon chip 22kohm	
R648	241 2394 991	Carbon film 33ohm	RD14B2E300J
RT201	211 6079 907	Semi variable resistor 10kohm	
<b>CAPACITORS GROUP</b>			
C101	255 4213 972	Mylar film 0.01μF/50V	CQ93M1H103J (B)
C102		Chip capacitor 0.01μF/50V	
C104		Axial capacitor 0.047μF/50V (F)	U.S.A./Canada/Asia models
C105		Chip capacitor 1000pF/50V	
C106		Chip capacitor 0.01μF/50V	
C107		Chip capacitor 0.022μF/50V	
C151		Chip capacitor 0.01μF/50V	
C152		Chip capacitor 9pF	
C161	254 4260 045	Electrolytic 1μF/50V	CE04W1H010M
C162		Chip capacitor 0.01μF/50V	
C163	254 4256 033	Electrolytic 47μF/25V	CE04W1E470M
C164		Chip capacitor 0.01μF/50V	
C165		Chip capacitor 0.022μF/50V	
C166	254 3056 917	Electrolytic 1μF/50V (SME) BP	CE04D1H010MBP
C167,168		Chip capacitor 27pF	
C169		Chip capacitor 1000pF/50V	
C170		Chip capacitor 100pF/50V	
C171		Chip capacitor 1000pF/50V	
C201	254 4256 033	Electrolytic 47μF/25V	CE04W1E470M
C202-204		Chip capacitor 0.047μF/50V	
C205		Chip capacitor 0.01μF/50V	
C206	254 4260 045	Electrolytic 1μF/50V	CE04W1H010M
C207		Chip capacitor 0.01μF/50V	
C208	254 4256 033	Electrolytic 47μF/25V	CE04W1E470M
C209		Chip capacitor 0.047μF/50V	
C210	254 4260 045	Electrolytic 1μF/50V	CE04W1H010M
C211,212	254 4260 087	Electrolytic 10μF/50V	CE04W1H100M
C213	254 4260 045	Electrolytic 1μF/50V	CE04W1H010M
C214	254 4260 935	Electrolytic 0.47μF/50V	CE04W1HR47M
C215	254 4260 045	Electrolytic 1μF/50V	CE04W1H010M
C216	254 4258 031	Electrolytic 33μF/35V	CE04W1V330M
C217,218		Chip capacitor 0.047μF/50V	
C219	254 4260 061	Electrolytic 3.3μF/50V	CE04W1H3R3M
C220	254 4260 993	Electrolytic 22μF/50V	CE04W1H220M
C221	253 1194 959	Axial capacitor 1000pF/50V (B)	CK14B1H102K Asia model only
C221	254 4260 087	Axial capacitor 560pF/50V (B)	Except Asia model
C222		Chip capacitor 0.047μF/50V	
C223	254 4260 087	Electrolytic 10μF/50V	CE04W1H100M
C224,225		Mylar film 0.047μF/50V (AMZ)	U.S.A./Canada models

Ref. No.	Part No.	Part Name	Remarks
C224,225		Mylar film 0.033μF/50V (AMZ)	Except U.S.A./Canada model
C226,227		Chip capacitor 2700pF	Europe/U.K. models
C228,229	254 4260 058	Electrolytic 2.2μF/50V	CE04W1H2R2M
C230	254 4260 087	Electrolytic 10μF/50V	CE04W1H100M
C231	253 1197 914	Axial capacitor 0.1μF/50V (F)	CK14F1H104Z
C284,285		Chip capacitor 27pF	Except Asia model
C286	254 4256 033	Electrolytic 47μF/25V	CE04W1E470M
C287	254 4260 058	Electrolytic 2.2μF/50V	CE04W1H2R2M Except Asia model
C288	254 4256 033	Electrolytic 47μF/25V	CE04W1E470M Except Asia model
C289		Chip capacitor 330pF	Except Asia model
C290		Chip capacitor 560pF	Except Asia model
C291		Chip capacitor 0.01μF/50V	Except Asia model
C292	254 4256 033	Electrolytic 47μF/25V	CE04W1E470M Except Asia model
C294	255 1084 007	Mylar film 0.1μF/50V (AMZ)	CQ93M1H104K
C551,552		Chip capacitor 0.01μF/50V	Europe/U.K. models
C606	254 4250 929	Electrolytic 100μF/6.3V	CE04W0J101M
<b>OTHER PARTS GROUP</b>			
BL001	9LB H005 32	AM RF block	1
CF101	261 0064 007	Ceramic filter CFL-SFT10.7MS2	Europe/U.K. models 1
CF101	261 0064 007	Ceramic filter CFL-SFE10.7MA8	U.S.A./Canada/Asia models 1
CF102	261 0064 007	Ceramic filter CFL-SFT10.7MS2	Europe/U.K. models 1
CF102	261 0136 906	Ceramic filter CFL-SFE10.7MS2G	Except Europe/U.K. models 1
FE101	9LH H000 31	Tuner pack	U.S.A./Canada/Asia models 1
FE101	9L2 4286 51	Tuner pack (4-TUNE)	Europe/U.K. models 1

## RECEIVER SECTION

Ref. No.	Part No.	Part Name	Remarks	Q'ty
IR601	9LC W002 01	Remote sensor module		1
T201	9LB J002 52	AM IFT (LA1873)		1
T202	9LB J004 22	FM DISCR coil		1
T203,204	9LB J004 11	LPF (19kHz)	Europe/U.K. models	2
X101	9L2 1701 32	Crystal 7.2MHz		1
X262	9L2 1701 33F	Crystal 4.332MHz	Except Asia model	1
X263	399 9018 003	Crystal 4.0MHz	Except Asia model	1
J020		Carbon chip 0ohm		1
J022		Carbon chip 0ohm		1
J032		Carbon chip 0ohm		1
J035		Carbon chip 0ohm		1
J042		Carbon chip 0ohm		1
J057		Carbon chip 0ohm		1
J058,059		Carbon chip 0ohm	U.S.A./Canada /Asia models	2
#001	9LN J017 11	FL holder		1
CN101A		10P socket (9130S)		1
CN102A	9LE Y001 02	13P socket (W)		1
CN103A	9LE D016 72	34P FFC connector (L)		1
CN104		3P connector (TXL) L=75	U.S.A./Canada models	1
CN104A	9LE D008 02	7P FFC connector (L)	Europe/U.K. models	1
CN105		5P PH connector		1
E001		Lug terminal		1
JK101	9LE U000 11	Antenna terminal board		1
JK502	9L2 6950 33	Headphone jack		1
PG201		3P pin post		1
S601-609	212 5604 910	Tact switch		9
	9LJT06991	Tuner / Display P.W.B. unit Ass'y	U.S.A./Canada models	1
	9LJT06992	Tuner / Display P.W.B. unit Ass'y	Europe model only	1
	9LJT06993	Tuner / Display P.W.B. unit Ass'y	U.K. model only	1
	9LJT06996	Tuner / Display P.W.B. unit Ass'y	Asia model only	1

WIRING DIAGRAM

RECEIVER SECTION

1 2 3 4 5 6 7 8

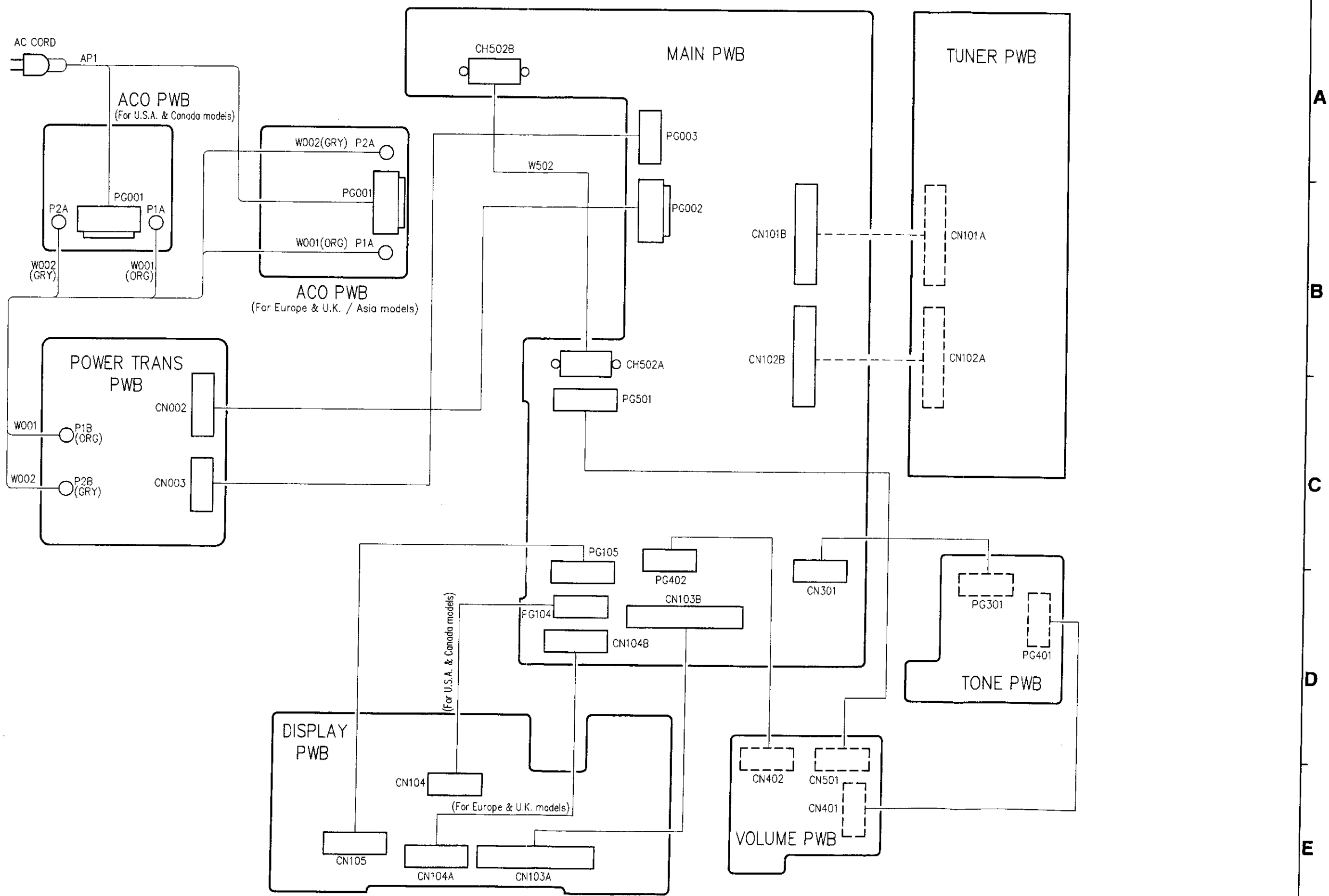

RECEIVER SECTION  
EXPLODED VIEW

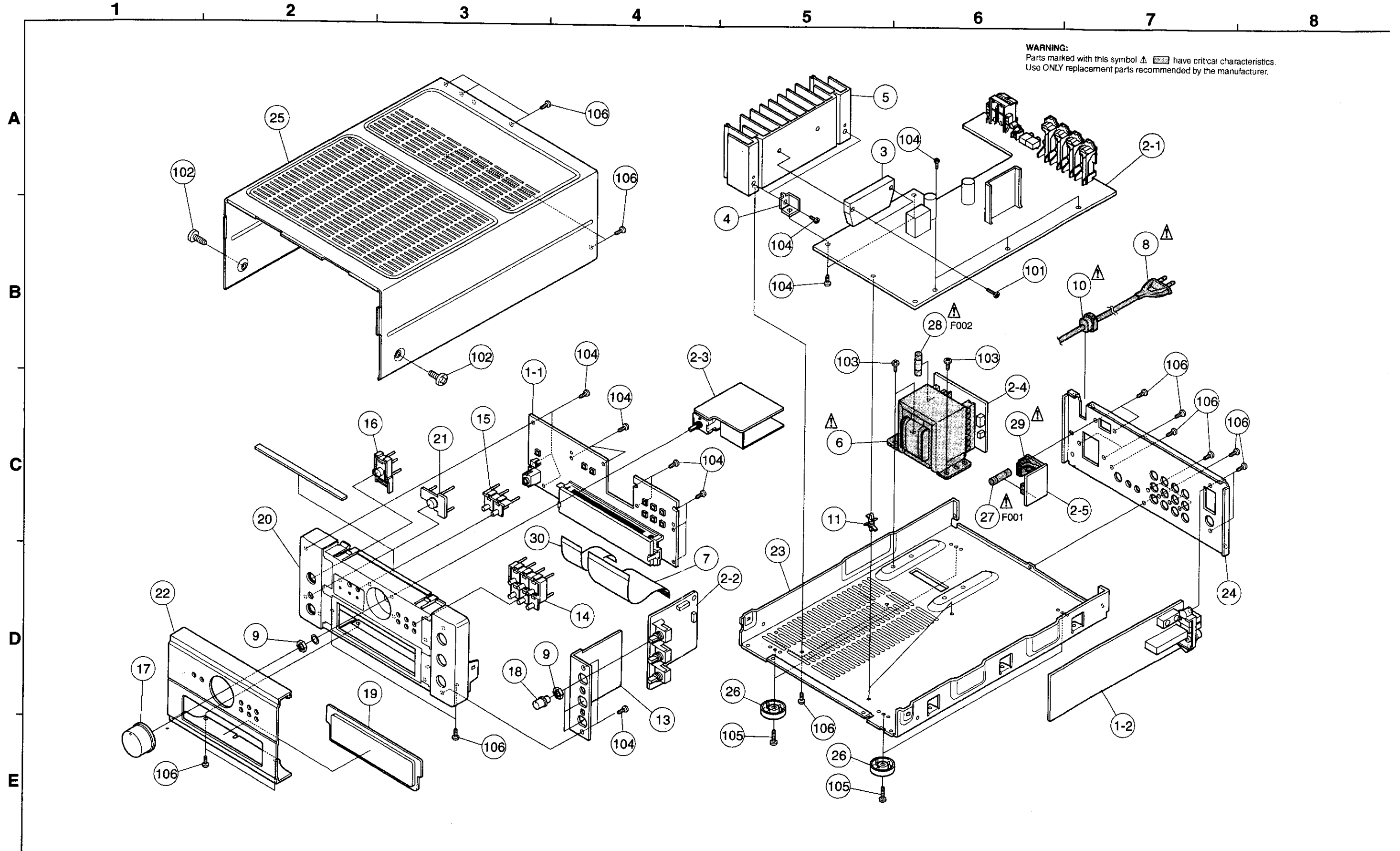

RECEIVER SECTION

1 2 3 4 5 6 7 8

ASIA MODEL

WARNING: Parts marked with this symbol  $\Delta$  have critical characteristics. Use ONLY replacement parts recommended by the manufacturer.

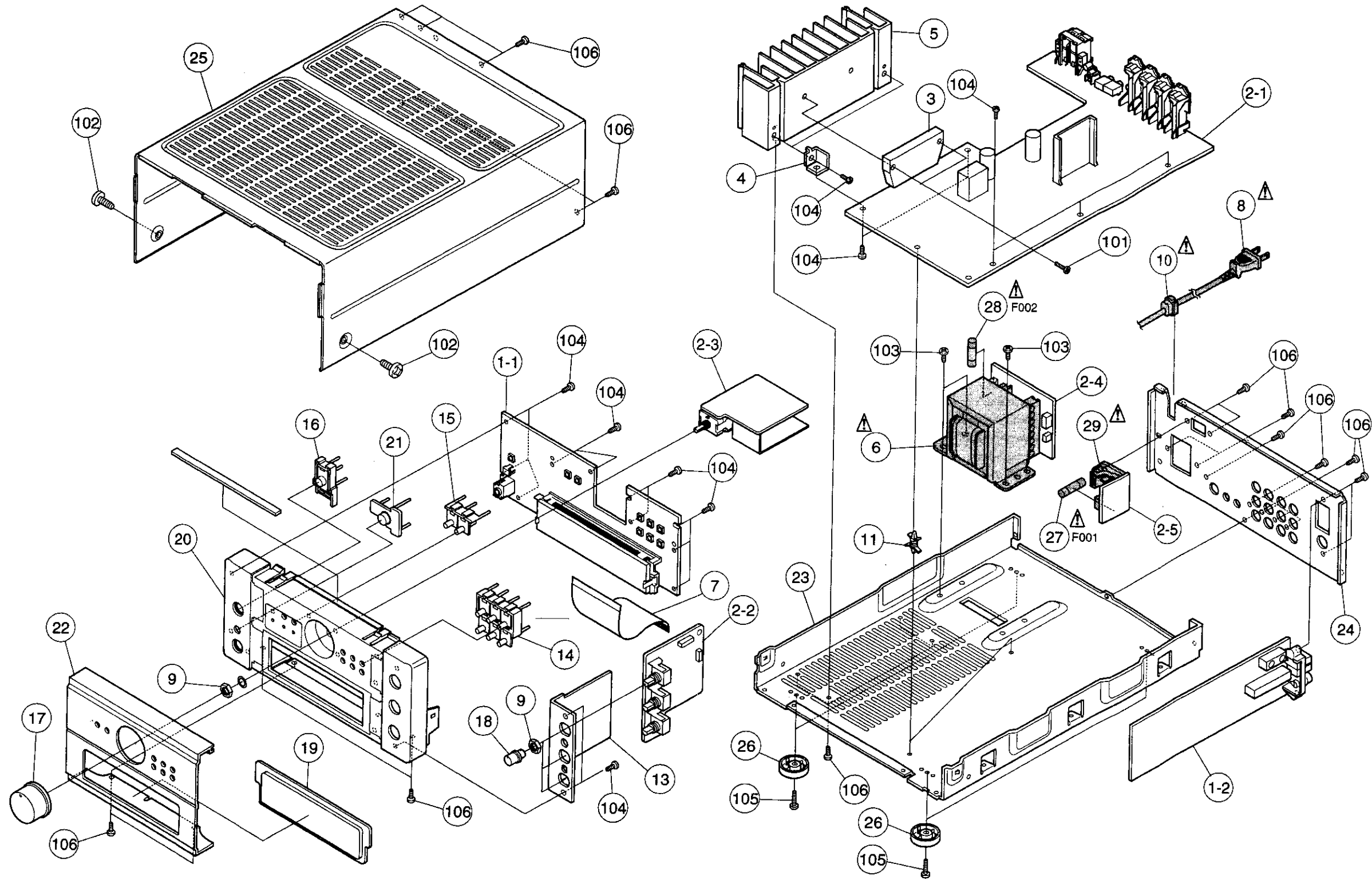

A

B

C

D

E

RECEIVER SECTION

PARTS LIST OF EXPLODED VIEW  
RECEIVER SECTION (UDRA-M7)

Ref. No.	Part No.	Part Name	Remarks	Q'ty
1	Note	Tuner / Display P.W.B. unit Ass'y		1s
1-1		Display unit		(1)
1-2		Tuner unit		(1)
2	Note	Main P.W.B. unit Ass'y		1s
2-1		Main unit		(1)
2-2		Tone unit		(1)
2-3		Volume unit		(1)
2-4		P.T unit		(1)
2-5		ACO unit		(1)
3	9LCP04522	IC STK405-050A	IC501	1
4		P.W.B.bracket		2
5		Heat sink		1
△ 6	Note	Power trans.		1
7	9LEK00158	34P FFC wire	W101	1
△ 8	Note	AC cord		1
9	475 6138 002	NUT M9x0.75		4
△ 10	Note	AC cord bushing		1
11	9LM L004 41	P.W.B. support		2
12	9LM S002 11	Felt		4
13		Tone bracket		1
14	9LP C022 61	Function button		1
15	9LP C022 81	Display button		1
16	9LP C022 91	Power button		1
17	9LP C023 01	Volume knob ass'y		1
18	9LP C023 31	Tone knob		3
19	9LP H045 71	Clear panel		1
20	9LP H045 81	Front panel (RE)		1
21	9LP H046 11	Remocon window		1
22	Note	Front panel (AL)		1
23	9LQ A008 91	Bottom chassis		1
24	Note	Rear plate		1
25	9LQ A009 11	Top cover		1
26	9LQ J003 91	Foot		4
△ 27	Note	Fuse F001	F001	1
△ 28	Note	Fuse F002	F002	1
△ 29	Note	AC outlet JK001	JK001	1
30	9LEK00235	7P FFC wire	W102 Europe/U.K. models	1
△ ★ 31	9LE P000 02	E.C. plug	U.K. model only	1
★ 32	9LP H046 01	RDS Indicator	Europe/U.K. models	1
★ 32	9LP H046 02	RDS Indicator	U.S.A./Canada models	1
★ 33		Caution label	U.S.A./Canada models	1
★ 34		Origin label	Asia model only	1
★ 35		Fuse caution label	U.S.A./Canada models	1

Ref. No.	Part No.	Part Name	Remarks	Q'ty
<b>SCREWS &amp; NUTS</b>				
101	9L8 6914 14	Screw BT 3x14		2
102		Screw 4x4 DT BIND B		2
103		Screw 4x6 DT BIND B		4
104	9L8 6914 10	Screw BH BT 3x10		18
105	9L8 6994 08	Screw BH BT 3x8 BBC		4
106	9L8 6994 10	Screw BH BT 3x10 BBC		23
<b>PACKING &amp; ACCESSORIES (Not included EXPLODED VIEW.)</b>				
201		UPC label	U.S.A./Canada models	1
202		Warranty card	U.S.A./Canada models	1
203	Note	Carton box		1
204	9LS P045 91	Cushion (CD)	for UDCM-M7	2
205	9LS P046 01	Cushion (RE)	for UDRA-M7	2
206	Note	Pory sack	for set	2
207		Origin label (S)	Asia model only	1
208		Poly bag		2
209	9LE F021 32	FM antenna connector		1
210	9LE W034 81	US pin cord		1
211	9LE W034 91	System cord		1
212	Note	Remote control unit		1
213	Note	Instruction manual		1
214	9L2 7132 25	1P US pin cord	L=2000 Asia model only	1
215	9L2 7593 41	AM loop antenna		1
216		Battery		1s
217	Note	Poly sack	for accessories	1

ADDENDUM PARTS LIST  
PARTS LIST OF EXPLODED VIEW

Ref. No.	Part Name	Part No.	Part No.	Part No.	Part No.
		U.S.A./Canada	Europe	U.K.	Asia
1	Tuner / Display P.W.B. unit Ass'y	9LJ T069 91	9LJ T069 92	9LJ T069 93	9LJ T069 96
2	Main P.W.B. unit Ass'y	9LJ T070 01	9LJ T070 02	9LJ T070 03	9LJ T070 06
△ 6	Power trans.	9LB T008 12	9LB T008 13	9LB T008 13	9LB T008 13
△ 8	AC cord	9LE V004 42	9LE V004 43	9LE V004 43	9LE V004 43
△ 10	AC cord bushing	9L3 8722 71	9LM L000 61	9LM L000 61	9LM L000 61
22	Front panel (AL)	9LP M048 71	9LP M048 72	9LP M048 72	9LP M048 73
24	Rear plate	9LQ A009 01	9LQ A009 02	9LQ A009 02	9LQ A009 03
△ 27	Fuse 1.6A 125V (F001)	9L2 7224 13	—	—	—
△ 27	Fuse T1A (F001)	—	9L2 7280 77	9L2 7280 77	9L2 7280 77
△ 28	Fuse 1.6A 125V (F002)	9L2 7224 13	—	—	—
△ 28	Fuse T1A (F002)	—	9L2 7280 77	9L2 7280 77	9L2 7280 77
△ 29	AC outlet	9LE P001 32	9LE P000 91	9LE P000 91	9LE P000 91
<b>PACKING AND ACCESSORIES</b>					
203	Carton box	9LS G064 51	9LS G064 52	9LS G064 52	9LS G064 53
206	Pory sack	9LS U010 21	9LS U010 21	9LS U010 20	9LS U010 21
212	Remote control unit RC828	9LH L009 01	9LH L009 01	9LH L009 01	—
212	Remote control unit RC831	—	—	—	9LH L009 02
213	Instruction manual	9LQ R216 11	9LQ R216 12	9LQ R216 12	9LQ R216 14
217	Poly sack	9L3 6402 14W	9L3 6402 14W	9L3 6402 13W	9L3 6402 14W

# SCHEMATIC DIAGRAM (1/2)

1 2 3 4 5

Part	R102	R103	R104	C101	R105	CF 101	CF 102	FE101	T203	J58	C226	R212	C224	C225	C221	A-BLOCK	B-BLOCK	C222	R213	C104	R113	R105	C232	
1 (A)	X	X	X	X	22	SFE10.7 MA-B	SFE10.7 MS20-A	3-TUNE	X	X	X	5.8K	0.047	50P	X	X	X	X	X	X	2.7K	1K	X	
2 (B)	X	X	X	X	22	SFT10.7 MS2-A	SFT10.7 MS2-A	4-TUNE	X	X	X	10K	0.033	50P	X	X	X	X	X	X	390	390	X	
6 (F)	X	X	X	X	22	SFE10.7 MA-B	SFE10.7 MS20-A	3-TUNE	X	X	X	10K	0.033	100P	X	X	X	X	X	X	2.7K	1K	X	
8 (H)	X	X	X	X	150	SFE10.7 MA-B	SFE10.7 MS20-A	3-TUNE	X	X	X	6.8K	0.033	100P	X	X	X	X	X	X	220	390	X	
NOTE	FM AGC				I-F FILTER		BAND-WIDTH		FRONT END		FM 19KHZ LPF		MUTE-BAND-BLOCK		DE-EMPHASIS		SEPARATION		RDS		AM STEREO		FM IF	

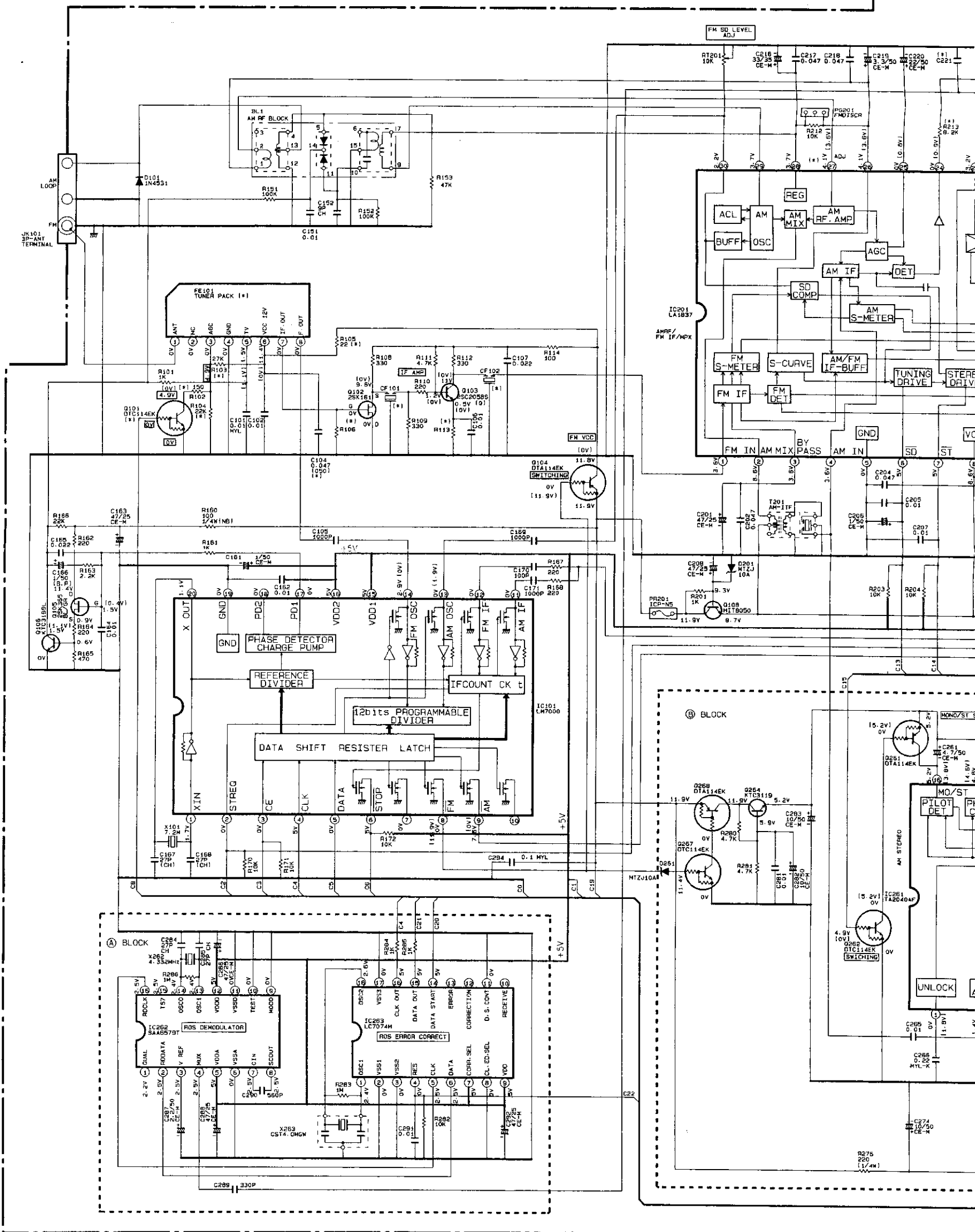

DISP. PWB ASS'Y UNIT TABLE OF DIFFERENCE

P1/O1	R506 R630 R631	R632~R635 D607 0608	CN104A 17PFFC1	CN104 3PMX1	C551 C552
1 (A) E3	○	×	×	○	×
2-3(B,C) E2/EK	○	○	○	×	○
6 (F) E1	×	×	×	×	×
8 (H) E1	×	×	×	×	×
J	×	×	×	×	×
NOTE	RT	RT, TA, PTY R D S		RT	O. DJU EMC

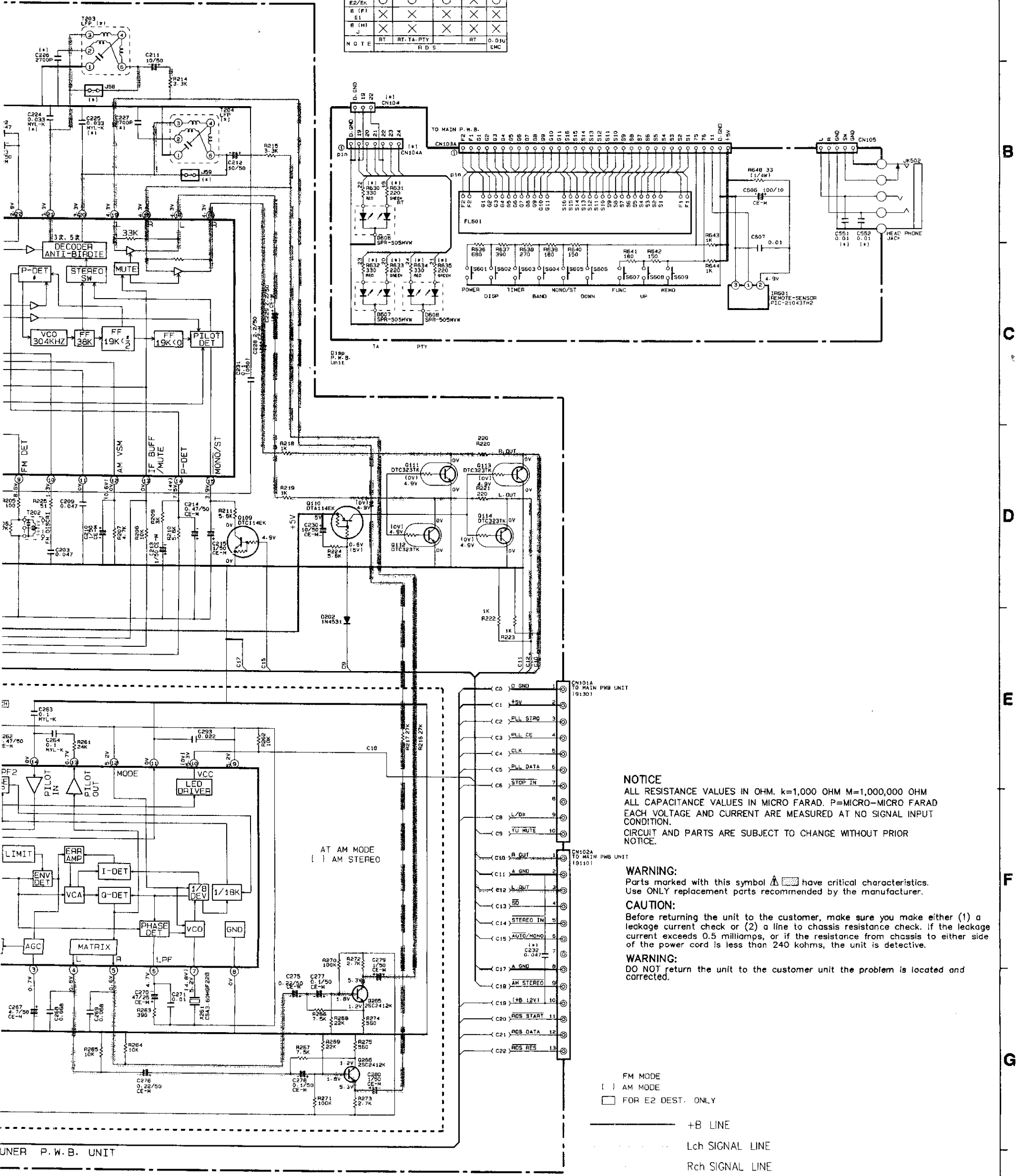

**NOTICE**  
ALL RESISTANCE VALUES IN OHM. k=1,000 OHM M=1,000,000 OHM  
ALL CAPACITANCE VALUES IN MICRO FARAD. P=MICRO-MICRO FARAD  
EACH VOLTAGE AND CURRENT ARE MEASURED AT NO SIGNAL INPUT  
CONDITION.  
CIRCUIT AND PARTS ARE SUBJECT TO CHANGE WITHOUT PRIOR  
NOTICE.

**WARNING:**  
Parts marked with this symbol have critical characteristics.  
Use ONLY replacement parts recommended by the manufacturer.

**CAUTION:**  
Before returning the unit to the customer, make sure you make either (1) a  
leakage current check or (2) a line to chassis resistance check. If the leakage  
current exceeds 0.5 milliamps, or if the resistance from chassis to either side  
of the power cord is less than 240 kohms, the unit is defective.

**WARNING:**  
DO NOT return the unit to the customer unit the problem is located and  
corrected.

FM MODE  
( ) AM MODE  
□ FOR E2 DEST. ONLY

— +B LINE  
- - - Lch SIGNAL LINE  
· · · Rch SIGNAL LINE

A  
B  
C  
D  
E  
F  
G  
H





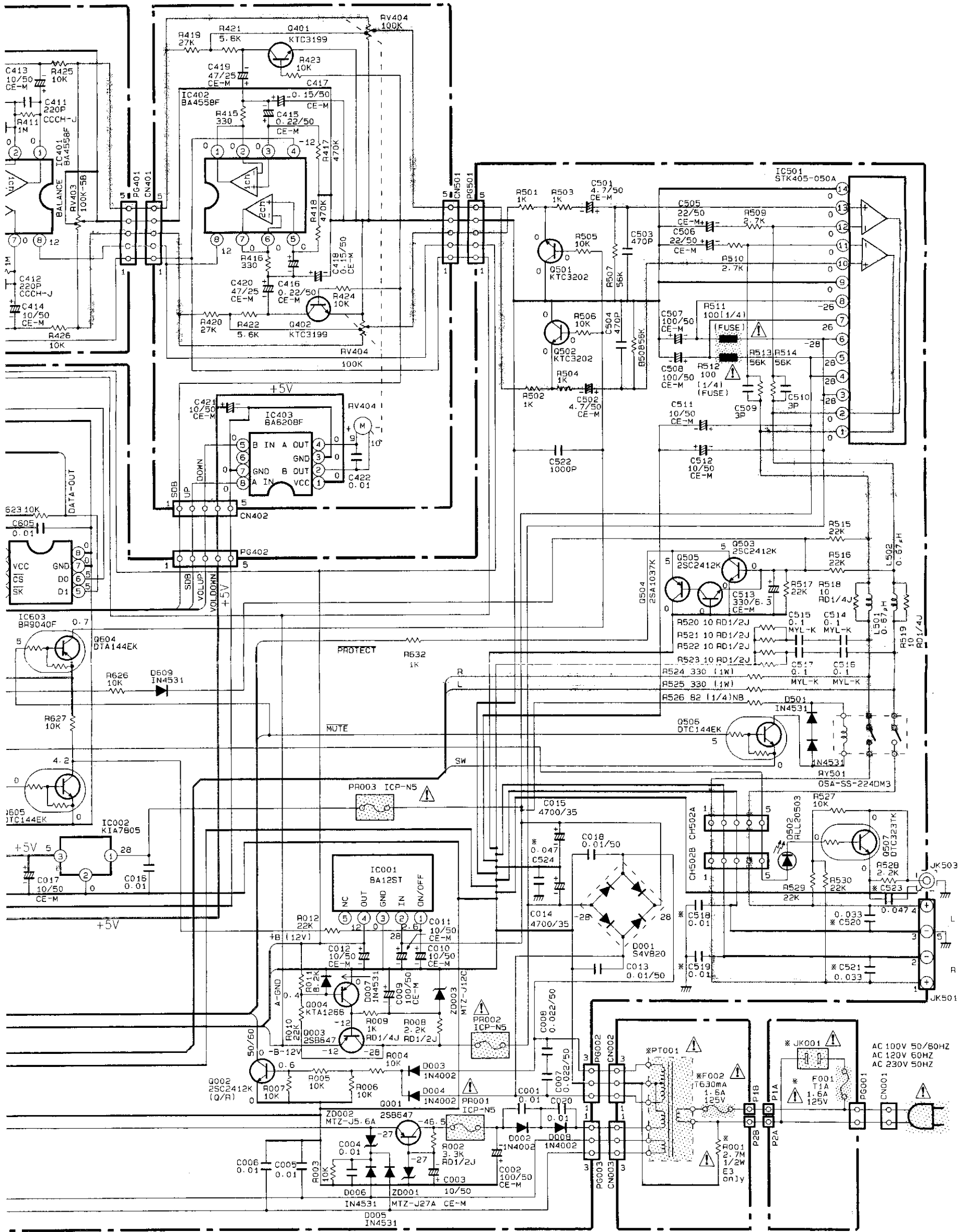

+B LINE  
 Lch SIGNAL LINE  
 Rch SIGNAL LINE

	E1	E2	E3	J
F001	T1A	T1A	1.6A125V	1.6A125V
F002	T630mA	T630mA	1.6A125V	1.6A125V

## DISASSEMBLY

(Follow in the reverse order for reassembly)

### 1. Top Cover

- (1) Remove 2 screws ① fixing from the both sides.
- (2) Remove 3 screws ② fixing to the Rear Panel.
- (3) Detach the Top Cover in the arrow direction.

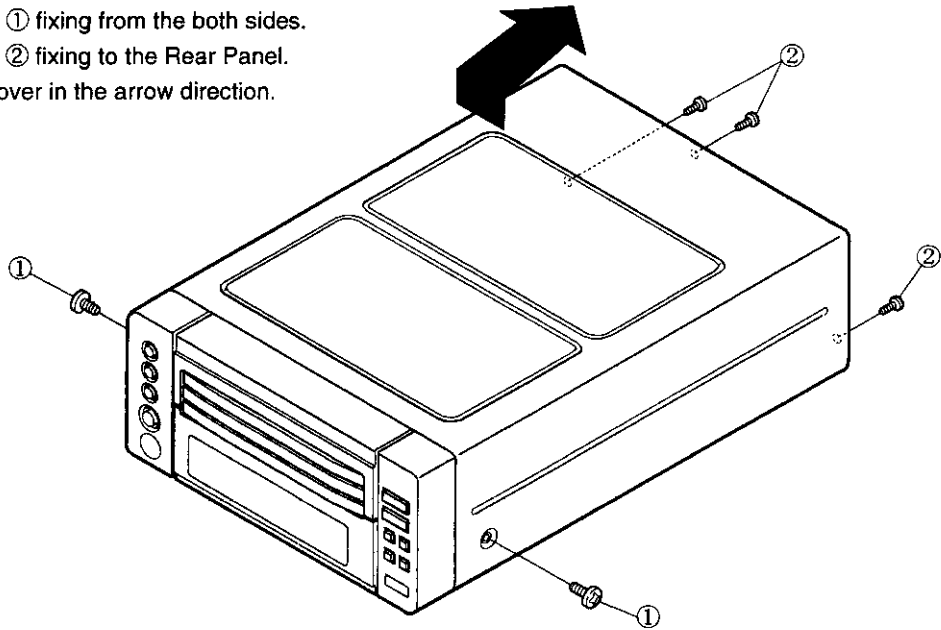

### 2. Front Panel

- (1) Disconnect 1 FFC cable coming from the Front P.W.B.
- (2) Disconnect 1 cord from the Front P.W.B. (Asia model only)
- (3) Remove 2 screws ③ at the bottom, then detach the Front Panel.

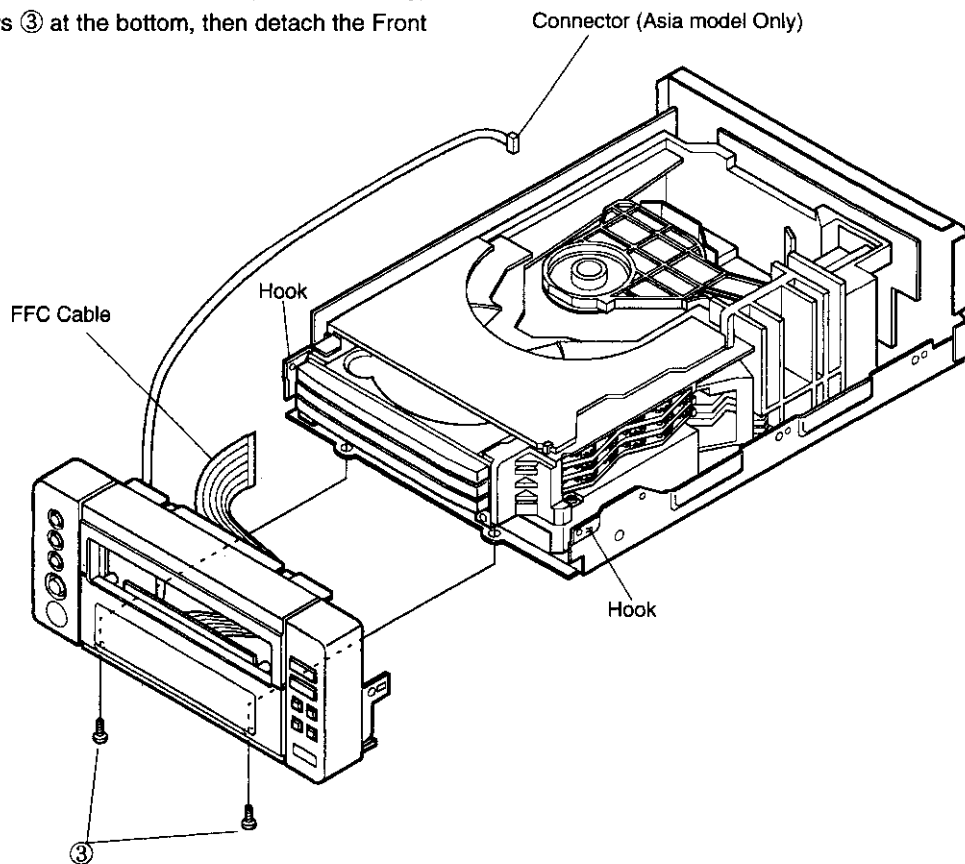

## CD PLAYER SECTION

**3. CD Mecha. ASS'Y**

- (1) Remove 1 screw ④ at the side P.W.B., and 2 screws ⑤ at the bottom.
- (2) Remove 2 screws ⑥ fixing the CD Mecha. and disconnect the connectors, then detach CD Mecha.

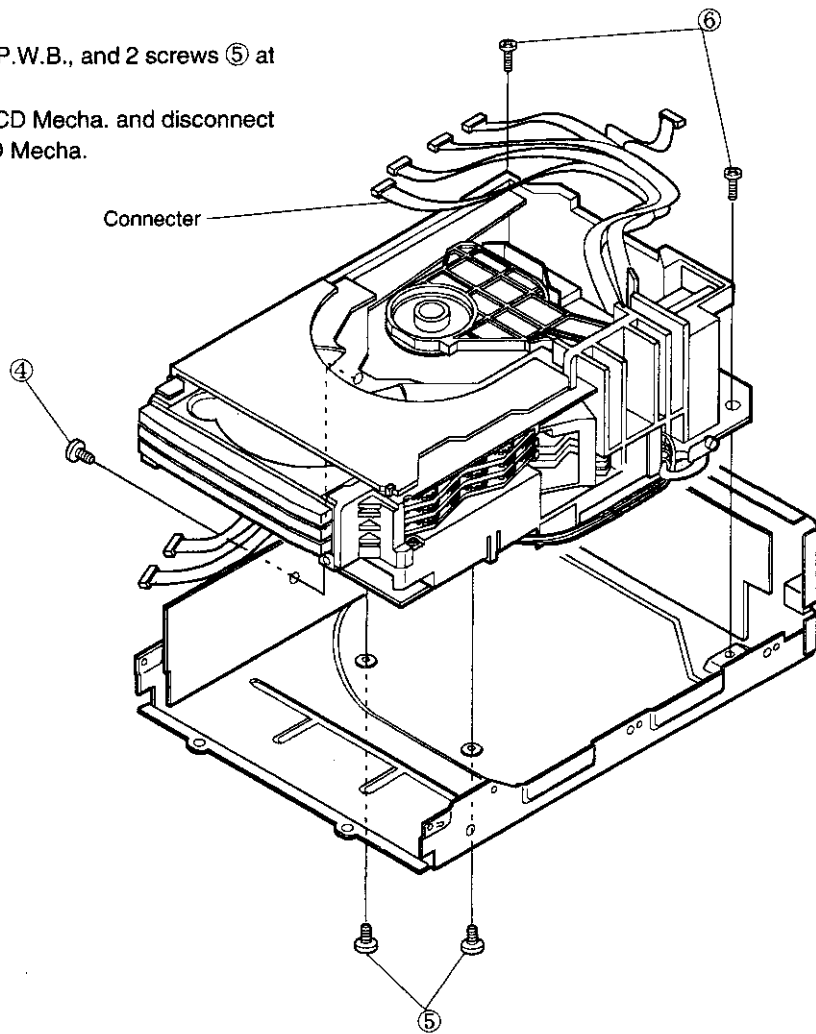
**4. Rear Panel**

- (1) Remove 7 screws ⑦, then detach the Rear Panel.

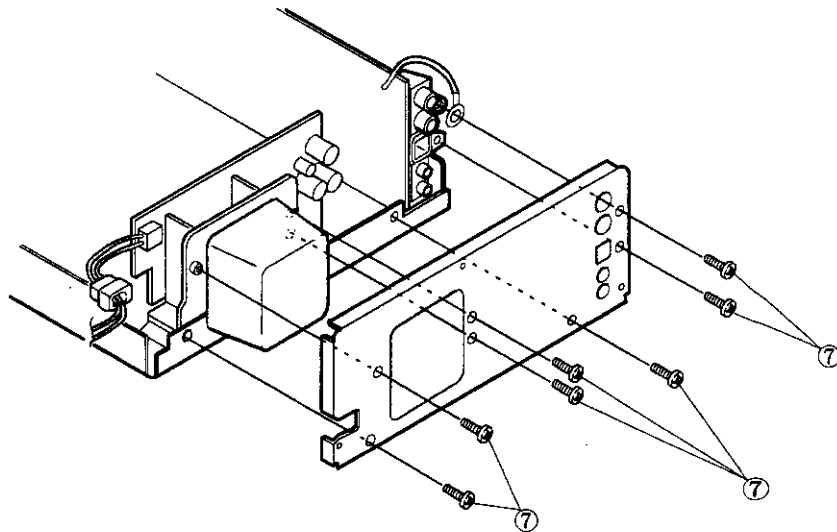

BLOCK DIAGRAM

CD PLAYER SECTION

1 2 3 4 5 6 7 8

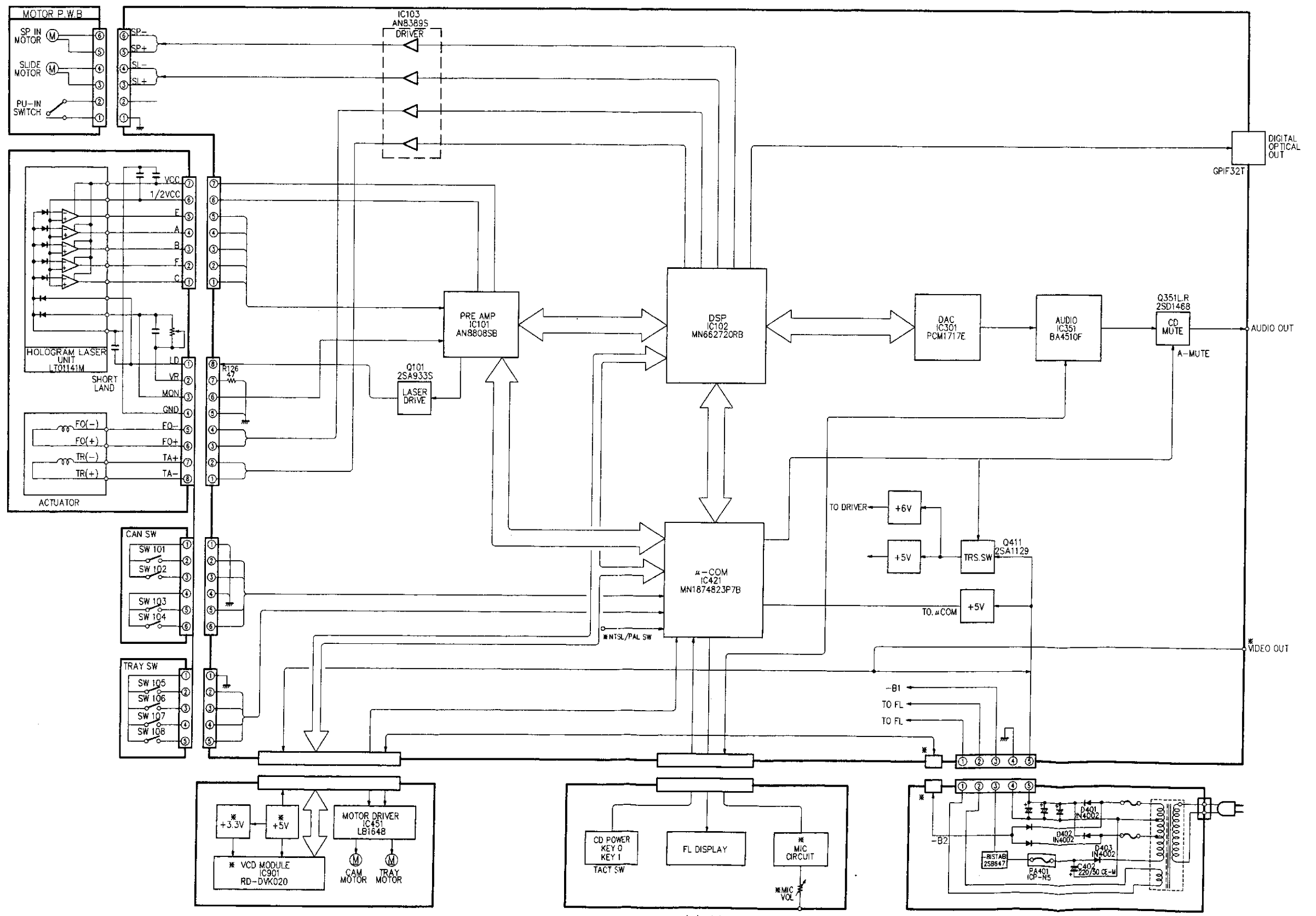

\* only for Asia \* MIC JACK

CD PLAYER SECTION

SEMICONDUCTORS

- IC's
- AN8808SB (IC101)

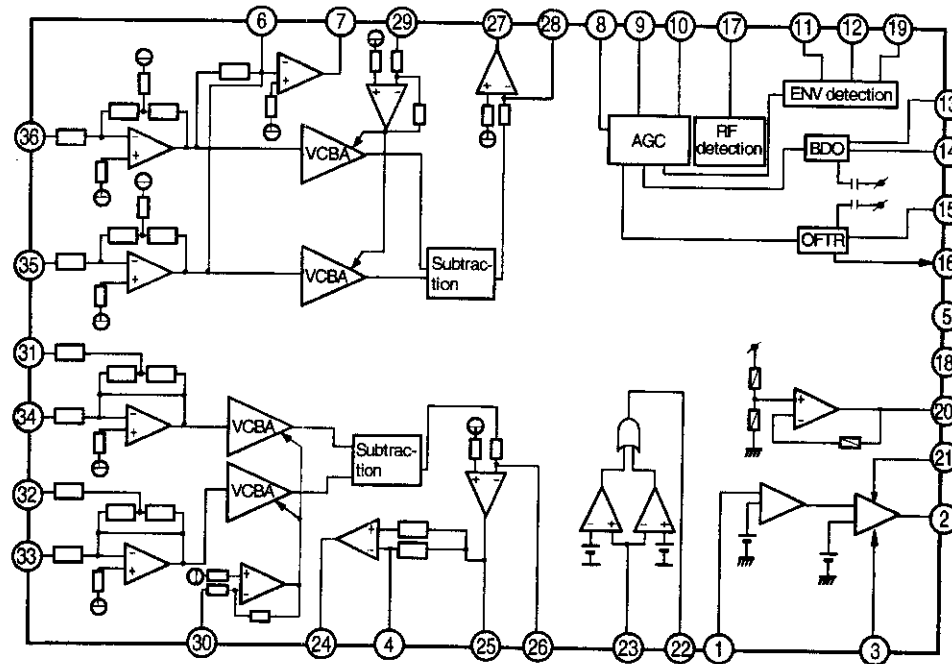
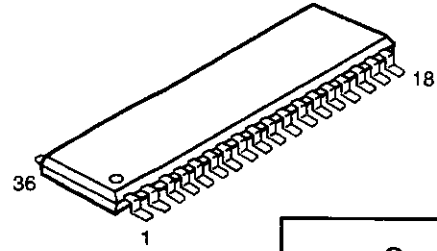

MN662720RB (IC102)

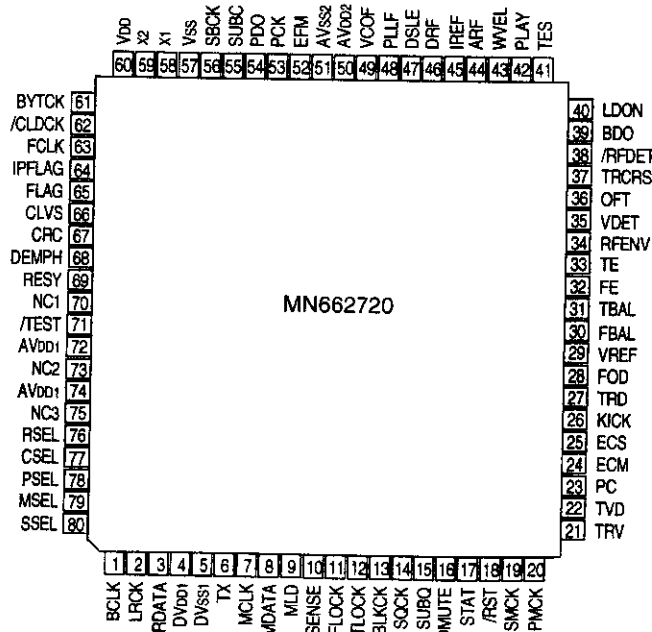
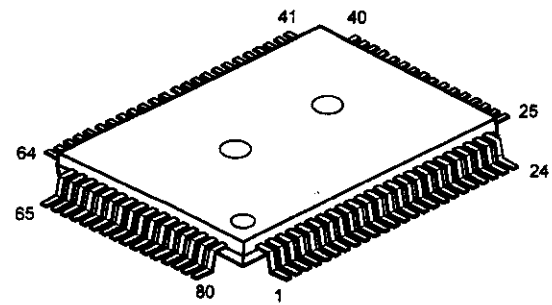

AN8389S (IC103)

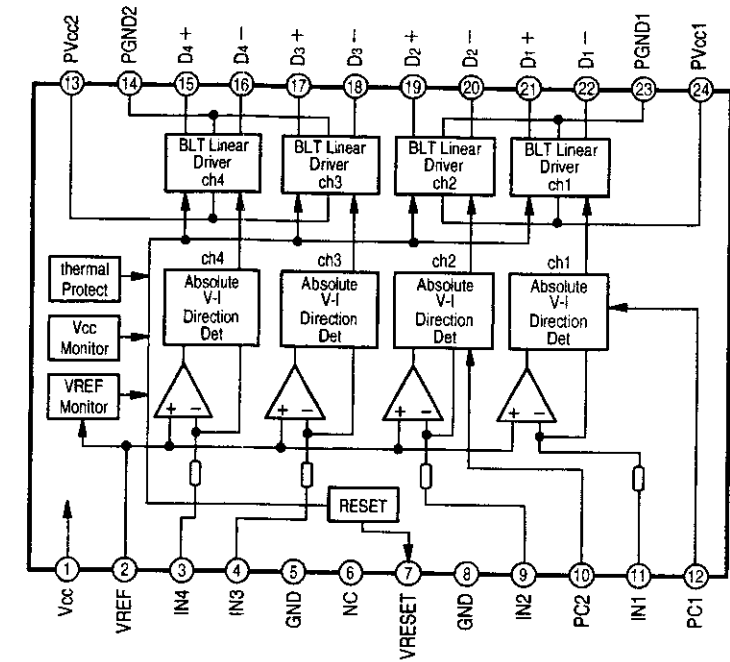
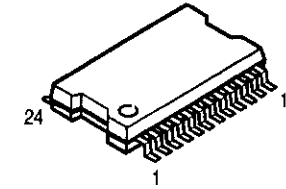

PCM1717E (IC301)

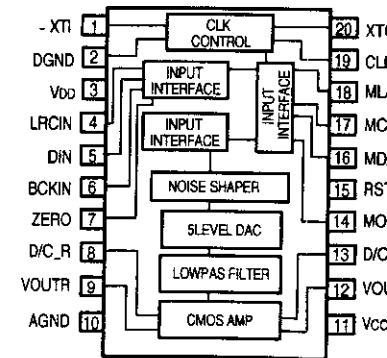
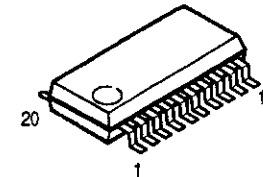

BA4510F (IC351)

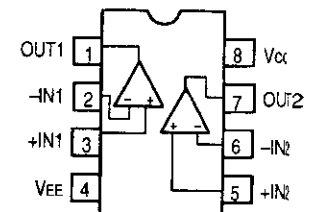
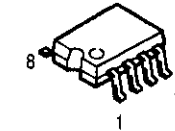

LB1648 (IC451)

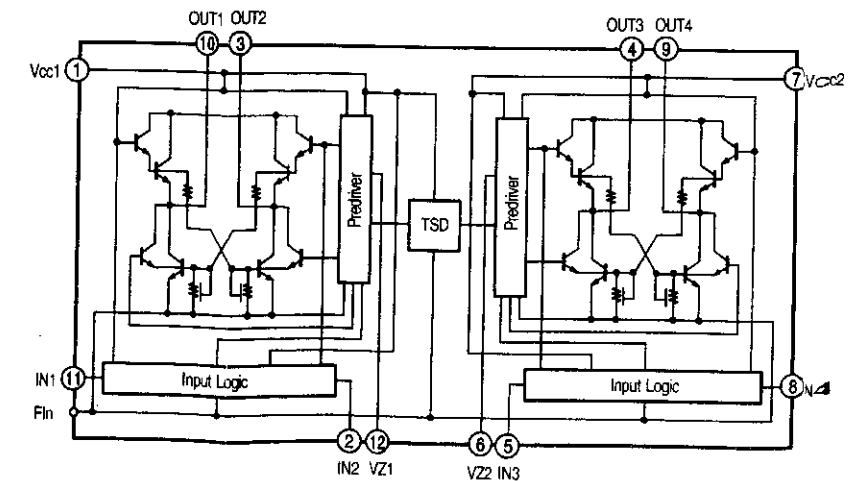
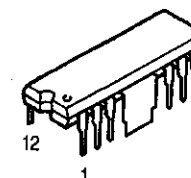

CD PLAYER SECTION

KIA7045P (IC422)

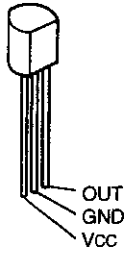

KIA7805PI (IC412, 413)  
KIA9806PI (IC414)

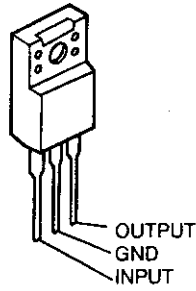

● IC PROTECTOR

ICP-N5 (PR401)

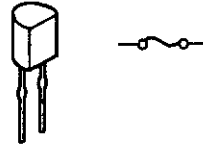

● TRANSISTOR

2SA1129 (K)

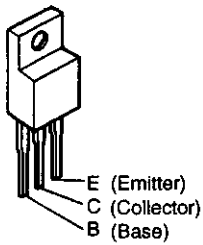

2SA933S (S)  
2SD1468S (R)  
2SC1740S (S)

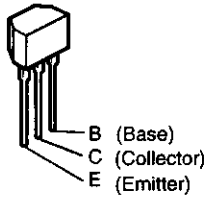

2SB647 (C)

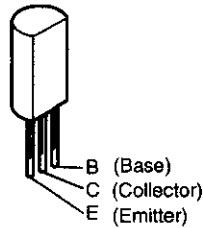

2SA844 (E)

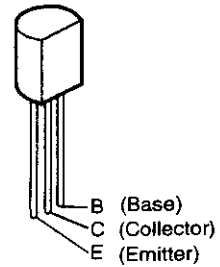

● OPITAL DIGITAL OUTPUT

GP1F32T (IC201)

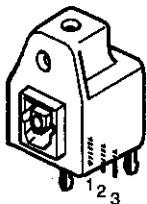

- 1. Vin
- 2. Vcc
- 3. GND

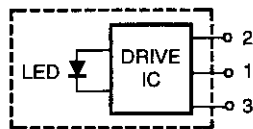

LED :Ga Al As  
DRIVE IC :Silicon

DTC124EK

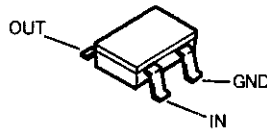

NPN Type

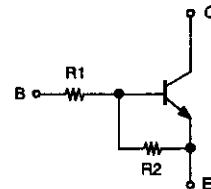

	R1	R2
DTC124EK	22 kohm	22 kohm

KTC3199L  
KTA1267

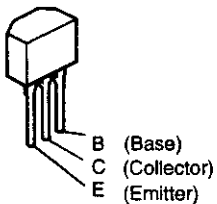

● DIODE

1N4531

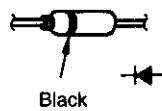

1N4002

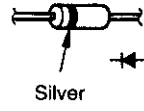

MTZJ2.7A MTZJ6.2A  
MTZJ3.9B MTZJ27A  
MTZJ5.6A

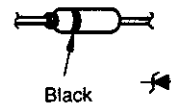

**CD PLAYER SECTION**

● **FL DISPLAY 10-BT-151GK (FL801)**

(Part No. : DD00071)

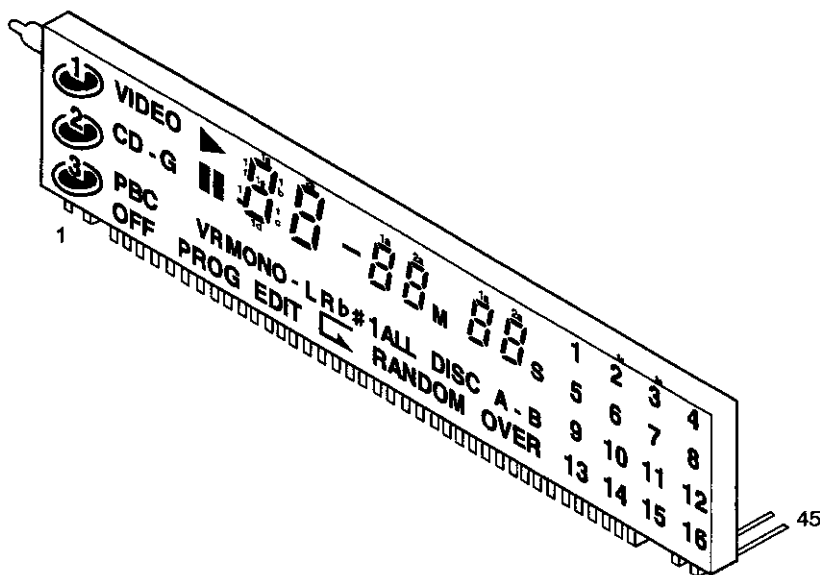

**Pin Connection**

Pin No.	1	2	3	4	5	6	7	8	9	10	11	12	13	14	15	16	17	18	19	20	21	22	23
Connection	F1	F1	NP	NP	P1	P2	P3	P4	P5	P6	P7	P8	P9	P10	P11	P12	P13	P14	P15	P16	NX	NX	NX

Pin No.	24	25	26	27	28	29	30	31	32	33	34	35	36	37	38	39	40	41	42	43	44	45
Connection	NX	NX	NX	NX	NX	NX	NX	NX	NX	NX	NX	NX	6G	5G	4G	3G	2G	1G	NP	NP	F2	F2

- NOTE**
- 1) F1,F2 ----- Filament
  - 2) NP ----- No Pin
  - 3) NX ----- No Extension
  - 4) DL ----- Datum Line
  - 5) 1G-6G ----- Grid
  - 6) Visible Angle (MIN) : 33° (Upper), 25° (Lower)



CD PLAYER SECTION

Grid Partition

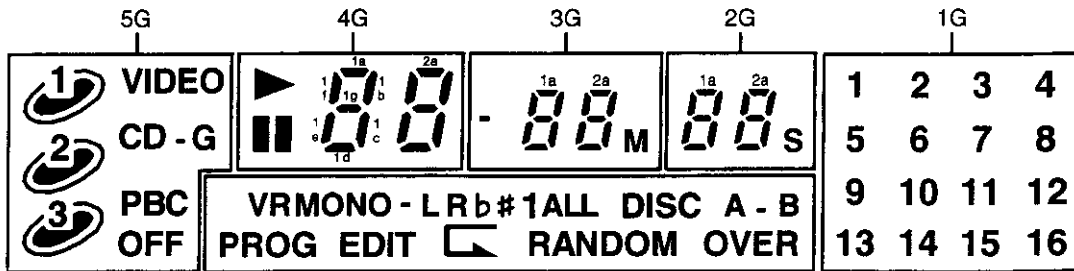

Illumination Color

Reddish Orange ----- Above pattern [ ] part

Green ----- Others

Anode Connection

	6G	5G	4G	3G	2G	1G
P1	VR	1	1a	1a	1a	1
P2	MONO -	[1]	1b	1b	1b	2
P3	L	[1]	1c	1c	1c	3
P4	R	2	1d	1d	1d	4
P5	1	[2]	1e	1e	1e	5
P6	ALL	[2]	1f	1f	1f	6
P7	DISC	3	1g	1g	1g	7
P8	A -	[3]	2a	2a	2a	8
P9	B	[3]	2b	2b	2b	9
P10	PROG	VIDEO	2c	2c	2c	10
P11	EDIT	CD	2d	2d	2d	11
P12	[ ]	-G	2e	2e	2e	12
P13	RANDOM	PBC	2f	2f	2f	13
P14	OVER	OFF	2g	2g	2g	14
P15	#	-	[ ]	-	-	15
P16	b	-	[ ]	M	S	16

**CD PLAYER SECTION**  
**MICROPROCESSOR DOCUMENTATION**  
**MN1874823P7B (IC421)**

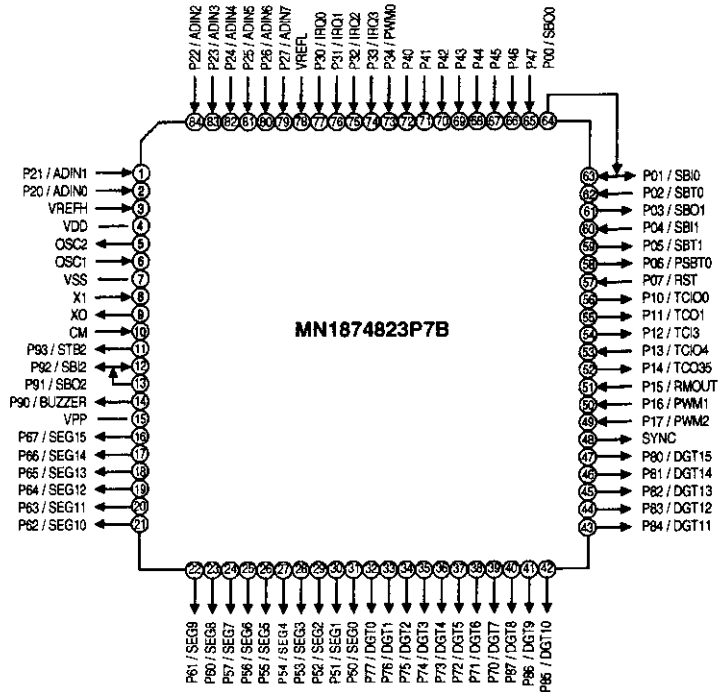
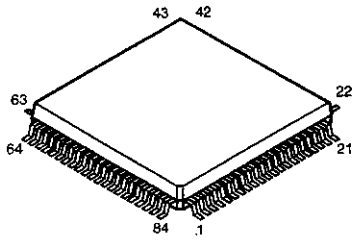

**HD6433726A76H Terminal Function**

Pin No.	Symbol	Port Name	I/O	INI	ACT	Function
1	KEY1	P21/ADIN1	I	-	H	Key scan input 1
2	KEY2	P20/ADIN0	I	-	H	Key scan input 0
3	VREFH	VREFH	I	VDD	VDD	Ref.V for analog input (High)
4	+5V	VDD	-	5V	5V	Power
5	4.32MHz	OSC2	O	-	-	µCOM system clock out
6	4.32MHz	OSC1	I	-	-	µCOM system clock in
7	GND	VSS	-	GND	GND	GND
8	X1	X1	I	-	-	µCOM system clock in
9	X0	X0	O	-	-	µCOM system clock out
10	CM	CM	I	GND	GND	Chip mode select input
11	—	P93/SBT2	O	H	L/H	Remote control signal in.
12	—	P92/SBI2	I	H	L	Pull up
13	—	P91/SBO2	O	H	L	NC
14	—	P90/BUZZER	O	H	L	NC
15	VPP	VPP	-	-	-	VPP
16	Seg 15	P67/Seg15	O	L	H	FL segment out 15
17	Seg 14	P66/Seg14	O	L	H	FL segment out 14
18	Seg 13	P65/Seg13	O	L	H	FL segment out 13
19	Seg 12	P64/Seg12	O	L	H	FL segment out 12
20	Seg 11	P63/Seg11	O	L	H	FL segment out 11
21	Seg 10	P62/Seg10	O	L	H	FL segment out 10
22	Seg 9	P61/Seg9	O	L	H	FL segment out 9
23	Seg 8	P60/Seg8	O	L	H	FL segment out 8
24	Seg 7	P57/Seg7	O	L	H	FL segment out 7
25	Seg 6	P56/Seg6	O	L	H	FL segment out 6
26	Seg 5	P55/Seg5	O	L	H	FL segment out 5
27	Seg 4	P54/Seg4	O	L	H	FL segment out 4
28	Seg 3	P53/Seg3	O	L	H	FL segment out 3
29	Seg 2	P52/Seg2	O	L	H	FL segment out 2
30	Seg 1	P51/Seg1	O	L	H	FL segment out 1

## CD PLAYER SECTION

Pin No.	Symbol	Port Name	I/O	INI	ACT	Function
31	Seg 0	P50/Seg 0	O	L	H	FL segment out 0
32	DGT0/KSCAN7	P77/DGT 0	O	L	H	FL grid output 0, Key scan output 7
33	DGT1/KSCAN6	P76/DGT 1	O	L	H	FL grid output 1, Key scan output 6
34	DGT2/KSCAN5	P75/DGT 2	O	L	H	FL grid output 2, Key scan output 5
35	DGT3/KSCAN4	P74/DGT 3	O	L	H	FL grid output 3, Key scan output 4
36	DGT4/KSCAN3	P73/DGT 4	O	L	H	FL grid output 4, Key scan output 3
37	DGT5/KSCAN2	P72/DGT 5	-	L	H	FL grid output 5, Key scan output 2
38	DGT6/KSCAN1	P71/DGT 6	O	L	H	FL grid output 6, Key scan output 1
39	—	P70/DGT 7	O	L		NC
40	TRYM -	P87/DGT 8	O			CD changer mecha tray monitor output -
41	TRYM +	P88/DGT 9	O			CD changer mecha tray monitor output +
42	CAMM -	P85/DGT 10	O			CD changer mecha tray monitor output -
43	CAMM +	P84/DGT 11	O			CD changer mecha cam motor output +
44	CDPWR	P83/DGT 12	O		L	CD power control output
45	DRVMT	P82/DGT 13	O	H	L	Driver mute output
46	DMUTE	P81/DGT 14	O	L	H	CD DSP mute output
47	AMUTE	P80/DGT 15	O			Audio DSP mute output
48	SYNC	SYNC	O	-	-	NC
49	TLOCK	P17/PWM 2	O	L	L	CD DSP TLOCK signal input
50	FLOCK	P16/PWM 1	O	L	L	CD DSP FLOCK signal input
51	SENSE	P15/RMOUT	I	L	H	CD-DSP SENSE signal input
52	MCLK	P12/TCO35	O	H	L/H	CD-DSP serial transmission clock output
53	STAT	P12/TCIO4	O	-	H	CD-DSP serial transmission status input
54	MDATA	P12/TCIO3	O	H	H	CD-DSP serial transmission data output
55	MLD	P11/TCO1	O	H	H	CD-DSP serial transmission load output
56	SRST	P10/TCIO0	O	L	H	Servo LSI reset output
57	RST	P07/RST	I	L	H	μCOM reset input
58	—	P06/PSBT0	O	L	H	Pull down
59	SQCK	P05/SBT1	O	H	L/H	Sub code (Q code) clock output
60	SUBQ	P04/SBI1	I	-	H	Sub code (Q code) data input
61	—	P03/SBO1	I	Hi-Z		NC
62	BUSCLK	P02/SBT0	I	-	L/H	DENON BUS transmission clock input
63	BUSIN	P01/SBI0	I	-		DENON BUS transmission data input
64	DATA	P00/SBO0	O			DENON BUS transmission data output
65	TRYSW4	P47	I	-		CD changer mecha tray SW input 4
66	TRYSW3	P46	I	-		CD changer mecha tray SW input 3
67	TRYSW2	P45	I	-		CD changer mecha tray SW input 2
68	TRYSW1	P44	I	-		CD changer mecha tray SW input 1
69	CAMSW4	P43	I	-		CD changer mecha cam SW input 4
70	CAMSW3	P42	I	-		CD changer mecha cam SW input 3
71	CAMSW2	P41	I	-		CD changer mecha cam SW input 2
72	CAMSW1	P40	I	-		CD changer mecha cam SW input 1
73	—	P34/PWM0	I	H	L	Pull up
74	PWRSW	P33/IRQ3	I			Power on input
75	—	P32/IRQ2	I	H	L	Pull up
76	—	P31/IRQ1	I	-	L/H	—
77	BUSINT	P30/IRQ0	I	-	L/H	DENON BUS communicate intervention input
78	VREFL	VREFL	I	GND	GND	Ref V for analog input (Low)
79	CD/VCD	P27/ADIN7	I	L	-	CD(L) and VCD switching input
80	LMTSW	P26/ADIN6	I	-	L	Pick-up inner circle position detect input
81	KEY5	P25/ADIN5	I	-	H	Key scan input 5
82	KEY4	P24/ADIN4	I	-	H	Key scan input 4
83	KEY3	P23/ADIN3	I	-	H	Key scan input 3
84	KEY2	P22/ADIN2	I	-	H	Key scan input 2

CD PLAYER SECTION  
PRINTED WIRING BOARD

1 2 3 4 5 6 7 8

CD UNIT ASS'Y  
Component Side

A

B

C

D

IT

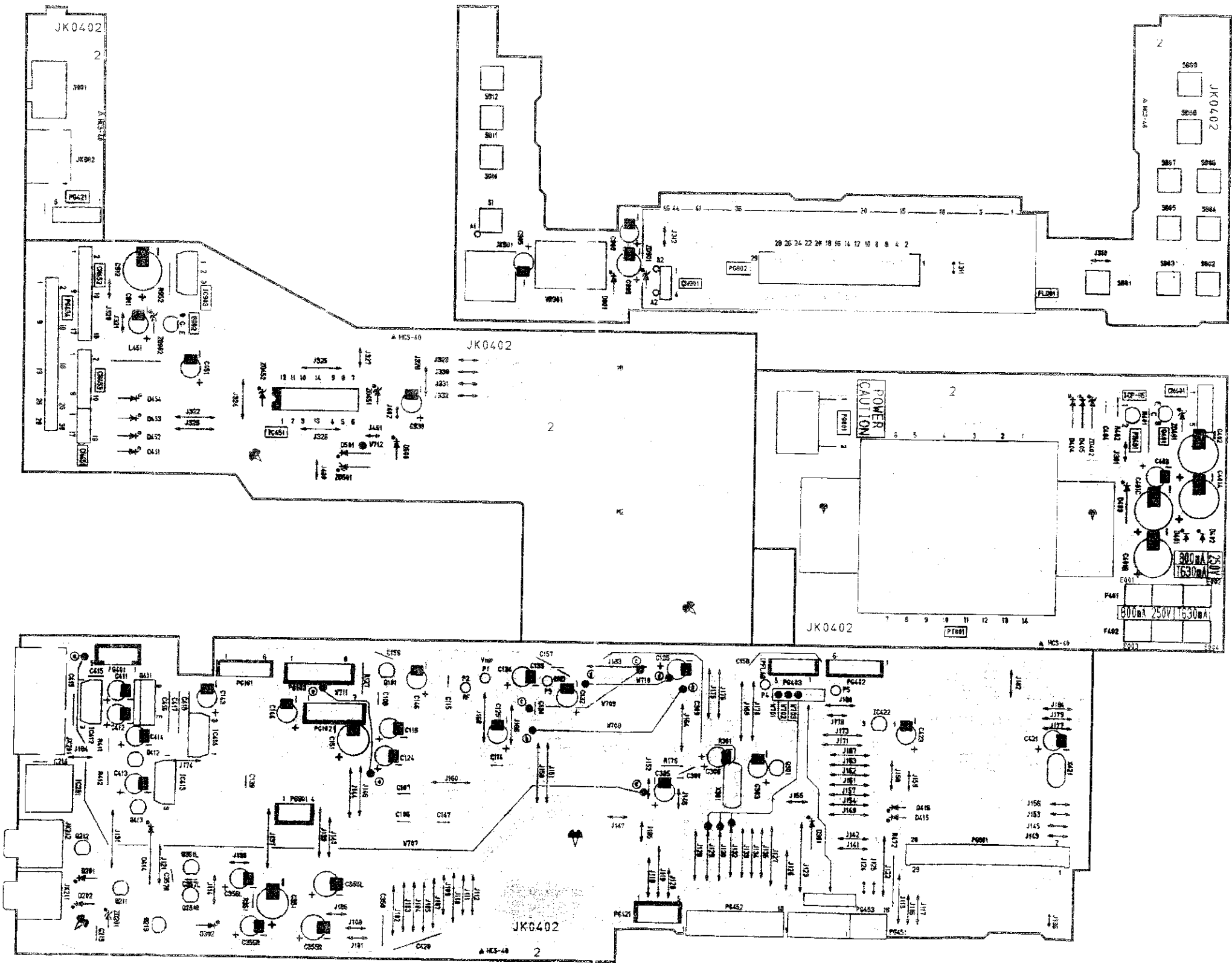







CD PLAYER SECTION

NOTE FOR PARTS LIST

- Part indicated with the mark "O" are not always in stock and possibly to take a long period of time for supplying, or in some case supplying of part may be refused.
- When ordering of part, clearly indicate "1" and "1" (i) to avoid mis-supplying.
- Ordering part without stating its part number can not be supplied.
- Part indicated with the mark "★" is not illustrated in the exploded view.
- Not including Carbon Film ±5%, 1/4W Type in the P.W.Board parts list. (Refer to the Schematic Diagram for those parts.)

WARNING:

Parts marked with this symbol have critical characteristics. Use ONLY replacement parts recommended by the manufacturer.

● Resistors

Ex.: RN 14K 2E 182 G FR  
 Type Shape Power Resist- Allowable Error Others  
 and per- ance error

RD	Carbon	2D	1/8W	F	±1%	P	Pulse-resistant type
RC	Composition	2E	1/4W	G	±2%	NL	Low noise type
RS	Metal oxide film	2H	1/2W	V	±5%	NB	Non-burning type
RW	Winding	3A	1W	K	±10%	FR	Fuse-resistor
RH	Metal film	3B	2W	M	±20%	F	Lead wire forming
RK	Metal mixtures	3F	3W				
		3H	5W				

\* Resistance  
 $\frac{1}{\uparrow} \frac{8}{\downarrow} \frac{2}{\downarrow} = 1800 \text{ ohm} = 1.8 \text{ kohm}$   
 Indicates number of zeros after effective number  
 2-digit effective number.  
 • Units: ohm

$\frac{1}{\uparrow} \frac{R}{\downarrow} \frac{2}{\downarrow} = 1.2 \text{ ohm}$   
 1-digit effective number.  
 2-digit effective number, decimal point indicated by R.  
 • Units: ohm

● Capacitors

Ex.: CE 04W 1H 2R2 M BP  
 Type Shape Dielectric Capacity Allowable Error Others  
 and per- strength error Others

CE	Aluminum foil electrolytic	6J	6.3V	F	±1%	HS	High stability type
CA	Aluminum solid electrolytic	1A	10V	G	±2%	BP	Non-polar type
CS	Niobium electrolytic	1C	10V	I	±5%	HR	Ripple resistant type
CQ	Film	1E	25V	K	±10%	DL	For charge and discharge
CK	Ceramic	1V	35V	M	±20%	HF	For assuring high frequency
CC	Ceramic	1H	50V	Z	+80%	U	UL part
CP	Oil	2A	100V		-23%	C	CSA part
CM	Mica	2B	125V	P	+100%	W	UL-CSA type
CF	Metalized	2C	160V		-0%	F	Lead wire forming
CH	Metalized	2D	200V	C	±0.25pF		
		2E	250V	D	±0.5pF		
		2H	500V				
		2J	630V				

\* Capacity (electrolyte only)  
 $\frac{2}{\uparrow} \frac{2}{\downarrow} \frac{2}{\downarrow} = 2200\mu\text{F}$   
 Indicates number of zeros after effective number.  
 2-digit effective number.  
 • Units:  $\mu\text{F}$

$\frac{2}{\uparrow} \frac{R}{\downarrow} \frac{2}{\downarrow} = 2.2\mu\text{F}$   
 1-digit effective number.  
 2-digit effective number, decimal point indicated by R.  
 • Units:  $\mu\text{F}$

\* Capacity (except electrolyte)  
 $\frac{2}{\uparrow} \frac{2}{\downarrow} \frac{2}{\downarrow} = 2200\text{pF} = 0.0022\mu\text{F}$   
 (More than 2) — Indicates number of zeros after effective number.  
 2-digit effective number.  
 • Units:  $\mu\text{F}$

$\frac{2}{\uparrow} \frac{2}{\downarrow} \frac{1}{\downarrow} = 220\text{pF}$   
 (0 or 1) — Indicates number of zeros after effective number.  
 2-digit effective number.  
 • Units: pF

• When the dielectric strength is indicated in AC, "AC" is included after the dielectric strength value.

PARTS LIST OF P.W.B. UNIT ASS'Y  
 CD CHANGER PLAYER UNIT ASS'Y

Ref. No.	Part No.	Part Name	Remarks	Ref. No.	Part No.	Part Name	Remarks
<b>SEMICONDUCTORS GROUP</b>							
IC101	9LC K077 21	IC 8808SB		ZD401	276 0645 949	Zener diode MTZJ-27A	27V
IC102	9LC K077 31	IC MN662720RB		ZD402	276 0643 996	Zener diode MTZJ-5.6A	5.6V
IC103	262 2143 000	IC AN8389S		ZD451	960 0013 401	Zener diode MTZJ-3.9B	3.9V
				ZD452	276 0637 902	Zener diode MTZJ-6.2A	6.2V
IC201	269 0098 006	GP1F32T (OPTICAL OUT)		ZD901	276 0643 925	Zener diode MTZJ-2.7A	2.7V
IC301	9LC K045 22P	IC PCM1717E					Asia model only
IC351	263 0934 900	IC BA4510F		ZD902	9L2 3480 72M	Zener diode MTZJ-3.9B	3.9V
							Asia model only
IC412,413	9LC P024 11	IC KIA7805PI		FL801	9LD 0000 71	FL Tube (6-ST-59GK)	
IC414	9LC P024 12	IC KIA7806PI		<b>RESISTORS GROUP</b>			
IC421	9LC K077 41	IC MN1874823P7B		R101,102		Carbon chip 22kohm	
IC422	9LC P007 12R	IC KIA7045P		R103,104		Carbon chip 47kohm	
IC451	9LC P025 41	IC LB1648		R105,106		Carbon chip 22kohm	
IC901	9LC W002 11	IC RD-DVK023K	Asia model only	R107		Carbon chip 390kohm	
IC902	263 0934 900	IC BA4510F	Asia model only	R108		Carbon chip 330kohm	
IC903	9LC P024 11	IC KIA7805PI	Asia model only	R109		Carbon chip 3.3kohm	
▲PR401	LA2 500U 216	IC protector ICP-N5		R110		Carbon chip 18kohm	
Q101	271 0183 914	Transistor 2SA933 (S)		R111		Carbon chip 22kohm	
Q211	9LC A006 61R	Transistor KTA1267(GR)		R112		Carbon chip 3.3kohm	
Q212	273 0303 910	Transistor 2SC1740S (S)		R114		Carbon chip 22kohm	
Q213	9LC A006 61R	Transistor KTA1267(GR)		R115		Carbon chip 220kohm	
Q301	9LC A006 41R	Transistor KTC3199L(GR)		R116		Carbon chip 1.8kohm	
Q351L,351R	274 0131 004	Transistor 2SD1468S		R117		Carbon chip 1.5kohm	
Q401	9L2 3286 25	Transistor 2SB647C		R118		Carbon chip 3.3kohm	
Q411	9L2 3243 62	Transistor 2SA1129K		R121		Carbon chip 10kohm	
Q412	9L2 3280 33T	Transistor 2SA844E		R122		Carbon Chip 100ohm	
Q413	269 0062 906	Transistor DTC124ES		R126		Carbon Chip 47ohm	
Q901	273 0384 900	Transistor 2SC2412KT	Asia model only	R127	241 2394 043	Carbon film 18ohm 1/4W	RD14B2E110J
Q902	274 0036 002	Transistor HIT5609C	Asia model only	R152		Carbon chip 68kohm	
D201,202	276 0401 905	Diode 1N4531/ISS133		R153		Carbon chip 120kohm	
D301,302	276 0401 905	Diode 1N4531/ISS133		R154		Carbon chip 1Mohm	
D401-403	916 0053 008	Diode 1N4002		R155		Carbon chip 100kohm	
D404,405	276 0401 905	Diode 1N4531/ISS133		R157		Carbon Chip 150ohm	
D414-416	276 0401 905	Diode 1N4531/ISS133		R158		Carbon Chip 680ohm	
D417	916 0053 008	Diode 1N4002		R159		Carbon chip 1kohm	
D451-454	276 0401 905	Diode 1N4531/ISS133		R161		Carbon chip 22kohm	
D901	276 0401 905	Diode 1N4531/ISS133	Asia model only	R162		Carbon chip 47kohm	
ZD201	276 0637 902	Zener diode MTZJ-6.2A	6.2V	R163		Carbon chip 1.8kohm	
				R164		Carbon chip 2.7kohm	
				R165		Carbon chip 220kohm	
				R166		Carbon chip 1.8kohm	
				R167		Carbon chip 68kohm	
				R168		Carbon chip 1kohm	
				R169		Carbon chip 33kohm	
				R170		Carbon chip 330kohm	
				R171		Carbon chip 22kohm	
				R172		Carbon chip 1kohm	
				R173		Carbon chip 150kohm	



## CD PLAYER SECTION

Ref. No.	Part No.	Part Name	Remarks	Ref. No.	Part No.	Part Name	Remarks
R174		Carbon chip 12kohm		R868		Carbon chip 82kohm	
R175		Carbon Chip 100ohm		R869		Carbon chip 1.5kohm	
R201		Carbon Chip 470ohm		R870		Carbon chip 2.2kohm	
R211		Carbon chip 10kohm		R871		Carbon chip 3.9kohm	
R212,213		Carbon chip 22kohm		R901		Carbon Chip 470ohm	Asia model only
R214		Carbon chip 10kohm		R902		Carbon chip 47kohm	Asia model only
R215		Carbon chip 47kohm		R903		Carbon Chip 470ohm	Asia model only
R216		Carbon chip 10kohm		R904		Carbon chip 100kohm	Asia model only
R217-219		Carbon chip 22kohm		R905		Carbon chip 1kohm	Asia model only
R220		Carbon chip 10kohm		R906,907		Carbon chip 10kohm	Asia model only
R221		Carbon Chip 220ohm		R908		Carbon chip 100kohm	Asia model only
R222		Carbon Chip 100ohm		R909,910		Carbon chip 15kohm	Asia model only
R301		Carbon Chip 560ohm		R911,912		Carbon chip 100kohm	Asia model only
R302,303		Carbon chip 10kohm		R913L,913R		Carbon chip 1kohm	Asia model only
R304	241 2400 995	Carbon film 10Kohm 1/6W	RD14B2E103J (5)	R951		Carbon chip 10kohm	Asia model only
R351	241 0145 003	Carbon film 22ohm 1/2W	RD14B2H220J	R952		Carbon film 330ohm 1/6W	Asia model only
R352L,352R		Carbon Chip 680ohm		R953		Carbon chip 10kohm	Asia model only
R353L,353R		Carbon chip 10kohm		VR901	9L0 1581 09	Variable resistor 10kohm	Asia model only
R354L,354R		Carbon chip 2.2kohm		<b>CAPACITORS GROUP</b>			
R355L,355R		Carbon chip 68kohm		C105		Chip capacitor 330pF	
R356L,356R		Carbon Chip 680ohm		C106,107	255 1084 007	Mylar film 0.1μF/50V	CQ93M 1H104K
R357L,357R		Carbon chip 1kohm		C108	254 4260 977	Electrolytic 4.7μF/50V	CE04W 1H4R7M
R358		Carbon chip 1kohm		C109		Chip capacitor 680pF/50V	
R401	241 2399 970	Carbon film 3.3kohm 1/6W	RD14B2E332J (5)	C110		Chip capacitor 2200pF/50V	
R402	241 2400 995	Carbon film 10Kohm 1/6W	RD14B2E103J (5)	C111		Chip capacitor 0.1μF	
R411	241 2401 978	Carbon film 22Kohm 1/6W	RD14B2E223J (5)	C112		Chip capacitor 4700pF	
R412	241 2399 938	Carbon film 2.2Kohm 1/6W	RD14B2E222J (5)	C114,115	255 1084 007	Mylar film 0.1μF/50V	CQ93M 1H104K
R421		Carbon chip 47kohm		C116		Chip capacitor 4pF	
R422		Carbon chip 1kohm		C117		Chip capacitor 12pF	
R423		Carbon chip 10kohm		C118	254 4260 045	Electrolytic 1μF/50V	CE04W 1H010M
R424-432		Carbon chip 1kohm		C119		Chip capacitor 100pF/50V	
R433-440		Carbon chip 22kohm		C120		Chip capacitor 0.022μF	
R451-458		Carbon chip 10kohm		C121		Chip capacitor 4700pF	
R461-467		Carbon chip 10kohm		C122		Chip capacitor 2200pF/50V	
R469		Carbon chip 10kohm		C123		Chip capacitor 0.1μF	
R470		Carbon chip 10kohm	Asia model only	C124	254 4252 040	Electrolytic 220μF/10V (SME)	CE04W 1A220M
R471		Carbon chip 10kohm	Except Asia model	C125	254 4260 045	Electrolytic 1μF/50V (SSL)	CE04W 1H010M
R472	241 2400 995	Carbon film 10Kohm 1/6W	RD14B2E103J (5) Except Asia model	C126		Chip capacitor 560pF	
R473,474		Carbon chip 10kohm	Except Asia model	C127,128		Chip capacitor 0.022μF	
R851,852		Carbon chip 15kohm		C130	255 1084 007	Mylar film 0.1μF/50V (AMZ)	CQ93M 1H104K
R861		Carbon chip 1.5kohm		C132	254 4196 928	Electrolytic 0.33μF/50V (SRA)	E04W 1H33M(SRA)
R862		Carbon chip 2.2kohm		C133	255 1084 007	Mylar film 0.1μF/50V	CQ93M 1H104K
R863		Carbon chip 2.7kohm		C134,135	254 4252 037	Electrolytic 100μF/10V	CE04W 1A101M
R864		Carbon chip 5.6kohm		C136		Chip capacitor 0.1μF	
R865		Carbon chip 8.2kohm		C137		Chip capacitor 100pF/50V	
R866		Carbon chip 15kohm		C139	255 1086 005	Mylar film 0.15μF/50V	CQ93M 1H154K
R867		Carbon chip 33kohm		C140		Chip capacitor 4700pF	
				C141		Chip capacitor 0.015μF	

## CD PLAYER SECTION

Ref. No.	Part No.	Part Name	Remarks	Ref. No.	Part No.	Part Name	Remarks
C142		Chip capacitor 0.01 $\mu$ F		C912		Electrolytic 470 $\mu$ F/6.3V (SME)	Asia model only
C143,144	254 4252 037	Electrolytic 100 $\mu$ F/10V	CE04W1A101M	C913		Chip capacitor 1000pF/50V	Asia model only
C145		Chip capacitor 0.01 $\mu$ F		C914		Electrolytic 220 $\mu$ F/25V (SSL)	Asia model only
C146	254 4260 058	Electrolytic 2.2 $\mu$ F/50V	CE04W1H2R2M	C915	254 4252 040	Electrolytic 220 $\mu$ F/10V	CE04W1A220M
C147	255 1264 940	Mylar film 2200pF/50V	CQ93M1H222J(B)				Asia model only
C151	254 4252 053	Electrolytic 330 $\mu$ F/10V	CE04W1A331M	C916		Chip capacitor 0.1 $\mu$ F	Asia model only
C152-155		Chip capacitor 0.1 $\mu$ F		C917	254 4252 040	Electrolytic 220 $\mu$ F/10V	CE04W1A220M
							Asia model only
C211-213		Chip capacitor 1000pF/50V		C918		Chip capacitor 0.1 $\mu$ F	Asia model only
C214	HMA 1000 165	Axial capacitor 0.01 $\mu$ F/16V	CK14F1C103=				
C301	254 4252 040	Electrolytic 220 $\mu$ F/10V	CE04W1A221M	<b>OTHER PARTS GROUP</b>			
C302		Chip capacitor 0.01 $\mu$ F		LA451	9L2 1222 39M	LA axial coil 100K	1
C303	254 4410 921	Electrolytic 10 $\mu$ F/50V	CE04W1H100M	L901	9L2 2279 14M	Axial coil 3.3	Asia model only 1
C305,306	254 4410 921	Electrolytic 10 $\mu$ F/50V	CE04W1H100M	X301	399 0036 013	Crystal 16.9MHz	1
C307,308		Chip capacitor 22pF/50V		X421	399 0160 002	Crystal CST 8.0 MTW	1
C309		Chip capacitor 1000pF/50V		J001-016		Carbon Chip 0ohm	6
C310	253 1195 945	Axial capacitor 3300pF/16V (X)	CK14X1C332M	J177		Jumper pin L=10mm	1
C351	254 4256 059	Electrolytic 220 $\mu$ F/25V (SSL)	CE04W1E221M	J201-204		Carbon Chip 0ohm	4
C354L,354R		Chip capacitor 5600pF/50V		J210		Carbon Chip 0ohm	1
C355L,355R	254 4252 040	Electrolytic 220 $\mu$ F/10V	CE04W1A221M	S001	212 5604 910	Tact switch	1
C356L,356R	254 4252 008	Electrolytic 22 $\mu$ F/50V	CE04W1H220M	S801-803	212 5604 910	Tact switch	Asia model only 3
C357L,357R	255 1264 982	Mylar film 4700pF/50V	CQ93M1H472J(B)	S804-812	212 5604 910	Tact switch	9
C401A,401B	254 4254 792	Electrolytic 2200 $\mu$ F/16V	CE04W1C222M	S901	9L2 6225 21	Switch SW-SL2-2	Asia model only 1
C401C	254 4254 789	Electrolytic 1000 $\mu$ F/16V	CE04W1C102M	JK201	9LE R004 01	2P US pin jack	1
C402	254 4261 031	Electrolytic 220 $\mu$ F/50V	CE04W1H221M	JK211,212	9L2 6714 13	Mini jack (3.5)	2
C403	254 4261 015	Electrolytic 47 $\mu$ F/50V	CE04W1H470M	JK901	9L2 6950 33	Headphone jack	Asia model only 1
C404	253 1146 907	Ceramic 0.01 $\mu$ F/50V	CK45F1H103Z	JK902	9LE R002 41	1P US pin jack	Asia model only 1
C411-414	254 4260 087	Electrolytic 10 $\mu$ F/50V	CE04W1H100M	CN401		5P PH boardin	1
C415-419	HMA 1000 165	Axial capacitor 0.01 $\mu$ F/16V	CK14F1C103=	CN421		5P connector	Asia model only 1
C421	254 4252 037	Electrolytic 100 $\mu$ F/10V	CE04W1A101M	CN451		6P BTEM connector	Except Asia model 1
C422		Chip capacitor 0.01 $\mu$ F		CN452,453		18P BTEM connector	Asia model only 2
C423	254 4260 977	Electrolytic 4.7 $\mu$ F/50V (SSL)	CE04W1H4R7M	CN901		4P TXL connector	Asia model only 1
C451	254 4252 037	Electrolytic 100 $\mu$ F/10V (SME)	CE04W1A101M	E001-004	9L2 7292 52R	Fuse holder	4
C452-454		Chip capacitor 0.01 $\mu$ F		E201		Lug terminal	1
C801,802		Chip capacitor 560pF					
C901		Chip capacitor 0.01 $\mu$ F	Asia model only				
C902	254 4196 009	Electrolytic 0.1 $\mu$ F/50V (SRA)	CE04W1H0R1M(SRA)				
C903		Chip capacitor 330pF	Asia model only				
C904		Chip capacitor 4700pF	Asia model only				
C905	254 4196 054	Electrolytic 2.2 $\mu$ F/50V (SRA)	CE04W1H2R2M(SRA)				
C906	254 4193 031	Electrolytic 47 $\mu$ F/16V (SRA)	CE04W1C470M(SRA)				
C907		Chip capacitor 56pF/50V	Asia model only				
C908	254 4193 002	Electrolytic 10 $\mu$ F/16V (SRA)	CE04W1C100M(SRA)				
C911		Electrolytic 47 $\mu$ F/25V (SSL)	Asia model only				

## CD PLAYER SECTION

Ref. No.	Part No.	Part Name	Remarks	Q'ty
E801	9LN J023 21	FL Holder		1
E804		Shield plate C	Asia model only	1
PG001		2P PLG-VH plug		1
PG101	9L2 6742 65	6P MX pin post		1
PG102	9L2 9590 56	7P PH pin post		1
PG103	9L2 9590 57	8P PH pin post		1
PG401		5P PH plug		1
PG402	9L2 6742 65	6P MX pin post		1
PG403	9L2 6742 64	5P MX pin post		1
PG421		5P TXL pin post	Asia model only	1
PG451		6P BTEM pin post	Except Asia model	1
PG452,453		18P BTEM pin post	Asia model only	2
PG454		30P BTEM pin post	Asia model only	1
PG801,802	9L2 6989 93	29P FFC connector (L)		2
PG901		4P TXL plug	Asia model only	1
P001-004		1 SQ pin		4
W701		UL wire L=60 PINK		1
W702		UL wire L=60 BLK		1
W703		UL wire L=50 BRN		1
W704		UL wire L=30 BLK		1
W705		UL wire L=25 BLK		1
W706		UL wire L=40 BLK		1
W707		UL wire L=180 BLK		1
#001		Shield plate (A)	Asia model only	1
#002		Shield plate B	Asia model only	1
	9LJ T070 41	CDC P.W.B. unit Ass'y	U.S.A./Canada models	1
	9LJ T070 42	CDC P.W.B. unit Ass'y	Europe model only	1
	9LJ T070 43	CDC P.W.B. unit Ass'y	U.K. model only	1
	9LJ T070 46	CDC P.W.B. unit Ass'y	Asia model only	1

CD PLAYER SECTION  
WIRING DIAGRAM

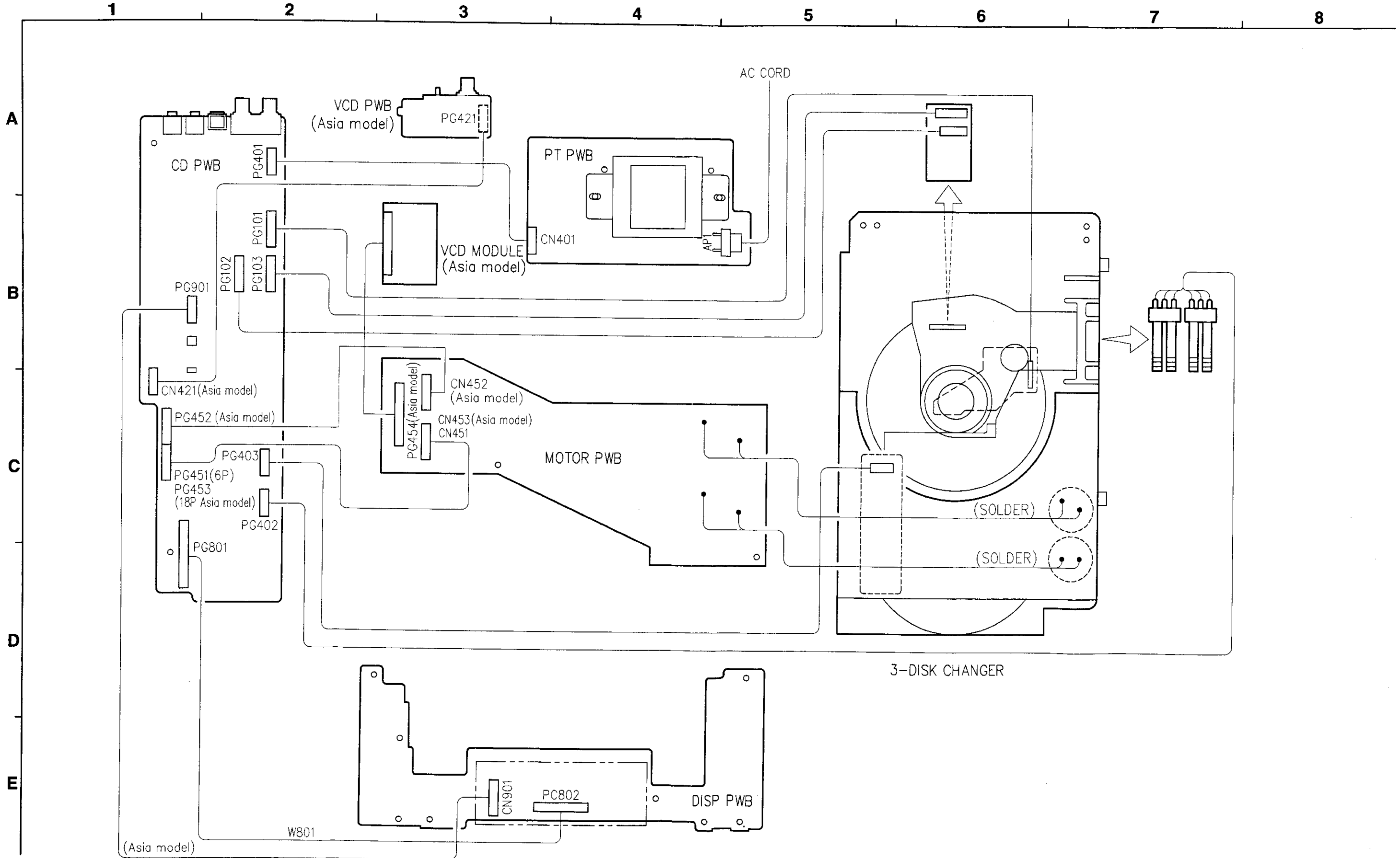

EXPLODED VIEW

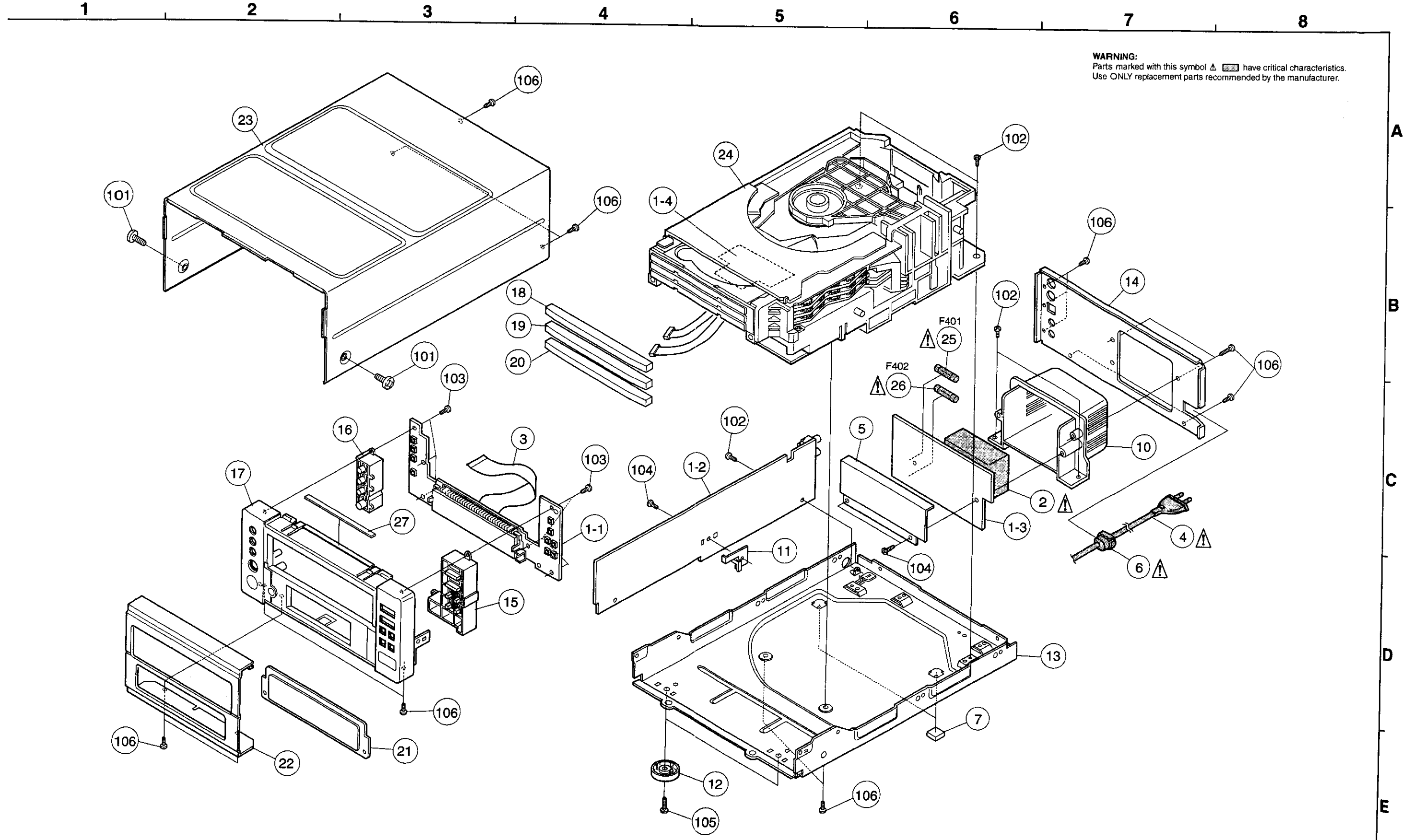

CD PLAYER SECTION

ASIA MODEL

WARNING:  
Parts marked with this symbol  have critical characteristics.  
Use ONLY replacement parts recommended by the manufacturer.

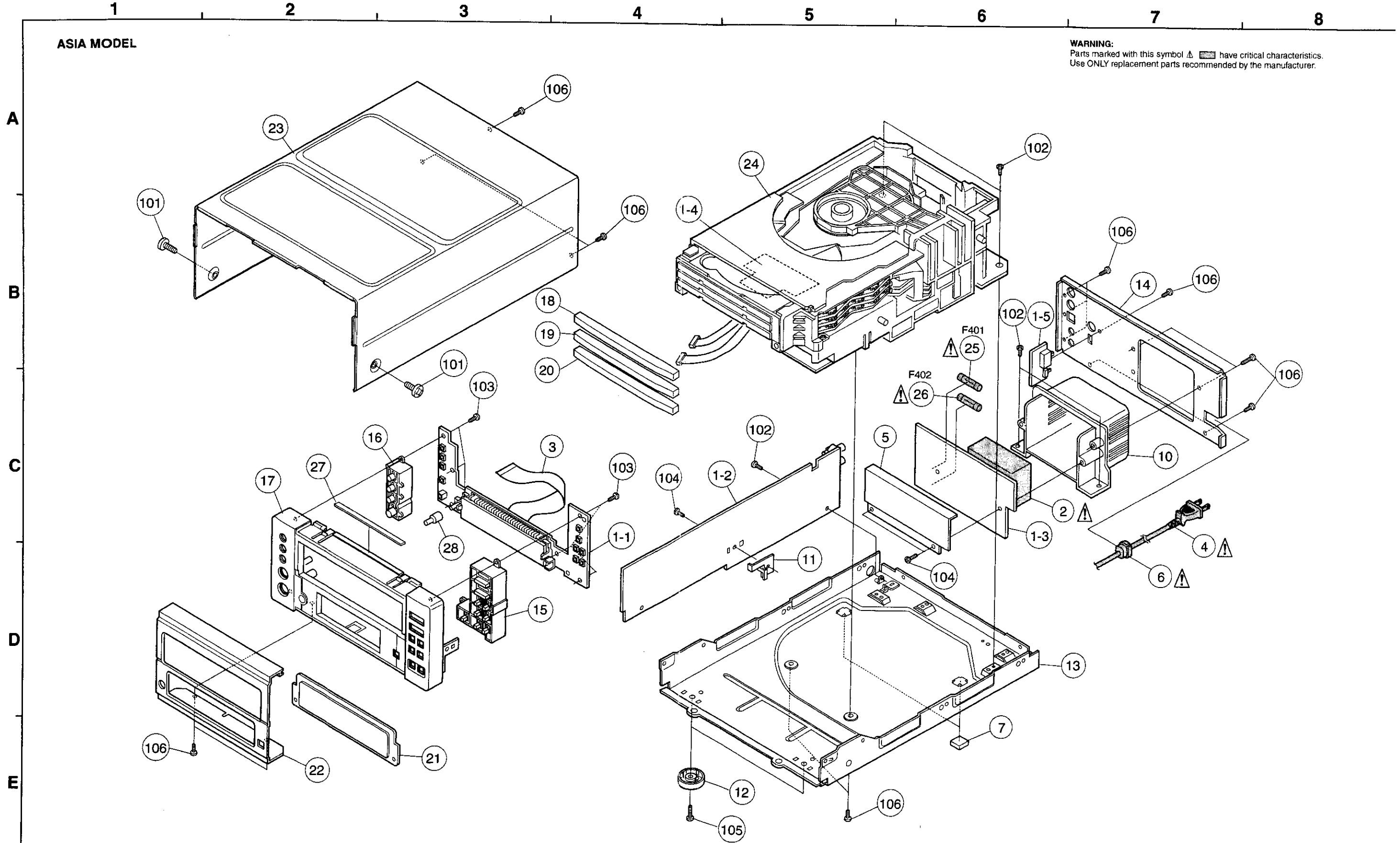

CD PLAYER SECTION

**PARTS LIST EXPLODED VIEW**  
**CD CHANGER PLAYER SECTION (UDCM-M7)**

Ref. No.	Part No.	Part Name	Remarks	Q'ty
1	Note	CDC P.W.B. unit Ass'y		1
1-1		Display unit		(1)
1-2		CD unit		(1)
1-3		P.T unit		(1)
1-4		Motor unit		(1)
1-5		VCD unit	Asia model only	(1)
2	Note	Power trans.		1
3	9LE K002 37	29P FFC cable	W801	1
4	Note	AC cord		1
5		Shield sheet		1
6	Note	AC cord bushing		1
7	9LM Q000 35	Leg		2
★	9LM S002 11	Felt		2
★	9LN A218 01	P.W.B bracket		1
10	9LN J023 11	PT Cover		1
11	9LN J023 31	P.W.B holder		1
12	9LN M007 31	Foot (30)		2
13	9LN Q046 01	Bottom chassis (CD)		1
14	Note	Rear plate		1
15	Note	Button (CD)		1
16	9LP C021 61	Button (P)		1
17	Note	Front panel		1
18	9LP H045 01	CD tray panel (1)		1
19	9LP H045 02	CD tray panel (2)		1
20	9LP H045 03	CD tray panel (3)		1
21	9LP H045 71	Clear panel		1
22	Note	Front metal (CD)		1
23	9LQ A009 13	Top cover		1
24	9LU C004 51	3-CD changer mecha Ass'y		1
25	Note	Fuse	F401	1
26	Note	Fuse	F402	1
27		Himeron sheet		1
28	9LP C021 71	Mic knob	Asia model only	1
★	29	Manufactured label	U.S.A./Canada models	1
★	30	Class label	Asia model only	1
★	31	Wire clasper	Europe model only	1
★	32	Origin label	Asia model only	1
★	33	Fuse caution label	U.S.A./Canada models	1
★	34	Caution label	U.S.A./Canada models	1
<b>SCREWS &amp; NUTS</b>				
101		Screw 4x4 DT BIND B		2
102	9L8 6914 08	Screw BH BT 3x8	Europe model only	1
102	9L8 6914 08	Screw BH BT 3x8		8
103	9L8 6914 10	Screw BH BT 3x10		7
104	9L8 6914 14	Screw BT 3x14		3

Ref. No.	Part No.	Part Name	Remarks	Q'ty
105	9L8 6994 08	Screw BH BT 3x8 BBC		2
106	9L8 6994 10	Screw BH BT 3x10 BBC		14
106	9L8 6994 10	Screw BH BT 3x10 BBC	Asia model only	1

**ADDENDUM PARTS LIST**  
**PARTS LIST OF EXPLODED VIEW**

Ref. No.	Part Name	Part No.	Part No.	Part No.	Part No.
		U.S.A./Canada	Europe	U.K.	Asia
1	CDC P.W.B. unit Ass'y	9LJ T070 41	9LJ T070 42	9LJ T070 43	9LJ T070 46
△	2 Power trans.	9LB T009 02	9LB T009 03	9LB T009 03	9LB T009 81
△	4 AC cord	9LE V004 42	9LE V004 43	9LE V004 43	9LE V004 43
△	6 AC cord bushing	9L3 8722 71	9LM L000 61	9LM L000 61	9LM L000 61
14	Rear plate	9LN Q046 11	9LN Q046 12	9LN Q046 12	9LN Q046 13
15	Button (CD)	9LP C021 51	9LP C021 51	9LP C021 51	9LP C021 52
17	Front panel	9LP H044 91	9LP H044 91	9LP H044 91	9LP H044 92
22	Front metal (CD)	9LP M048 01	9LP M048 01	9LP M048 01	9LP M048 02
△	25 Fuse T600mA 250V (F401)	9L2 7224 69	—	—	—
△	25 Fuse T600mA (F401)	—	9L2 7280 72	9L2 7280 72	9L2 7280 72
△	26 Fuse T600mA 250V (F402)	9L2 7224 69	—	—	—
△	26 Fuse T600mA (F402)	—	9L2 7280 72	9L2 7280 72	9L2 7280 72





## CD PLAYER SECTION

## PARTS LIST OF CD CHANGER MECHANIS M UNIT

Ref. No.	Part No.	Part Name	Remarks	Q'ty	Ref. No.	Part No.	Part Name	Remarks	Q'ty
<b>LOADER MECH. SECTION</b>					<b>TRAVERES SECTION</b>				
101		Main base	LCHSM0037AWZZ	1	1		Middle gear	NGERH0011AWZZ	1
102		Top board	LANGF0024AWZZ	1	2		Drav gear	NGERH0012AWZZ	1
103		Cam guide roller	NROLP0007AWZZ	3	3		Guide railroller	MLEVP0010AWZZ	1
104		Drive pulley	NPLYR0004AWZZ	2	4		Guide shaft	NSFTM0002AWFW	1
105		Idler gear	NGERH0052AWZZ	1	5		Gum cushion (gray)	PCUSG0427AFSC	2
106		Cam gear	NGERH0053AWZZ	1	6	9370227A03	Pickup unit	RCTRH8164AFZZ	1
107		Middle gear	NGERH0054AWZZ	1	7		Gum cushion (green)	PCUSG0004AWSA	1
108		Tray idler gear	NGERH0057AWZZ	12	8		Gum cushion (red)	PCUSG0001AWSA	1
109		Main cam	MCAMP0127AFZZ	1	9		Chassis with motor Ass'y	92LMTR1854CASY	1
110		Front switch lever	MLEVP0056AWZZ	2	10		Slide motor Ass'y	92LMTR1854BASY	1
111		Rear switch lever Ass'y	MLEVP0057AWM1	2	11		Limit switch	QSW-F9001AWZZ	1
112		Tray lock lever	MLEVP0058AWZZ	3					
113		Mecha holder	PGIDM0018AWZZ	1	51		Screw 2.6x6	92L2R6S+6CZ	2
114		Stabilizer holder	PGIDM0019AWZZ	1	52		Screw 2x5	92L2TTS+5BB	2
115		Stabilizer	LHLDM1008AWZZ	1	53		Screw 2x3	92L2S+3PZ	2
116		Mecha holder guide	PGIDM0017AWZZ	1	54		Cut washer 1.5x3.8x0.25mm	92L1R5WC3RBR25	1
119		Guide tray	GCOVA1126AWZZ	3					
120		Disk tray	GCOVA1127AWZZ	3					
121		Switch angle	LANGF0025AWZZ	1					
122		Tray change shaft	NSFTL0001AWZZ	1					
123		Tray switch spring	MSPRD0078AWFJ	4					
124		Tray lock lever epring	MSPRD0080AWFJ	3					
125		Disk stop spring	MSPRD0079AWFJ	1					
126		Tray drive belt	NBLT0028AWZZ	1					
127		Cam drive belt	NBLT0027AWZZ	1					
128		Magnet	PMAGF0001AWZZ	1					
129		Nylon band (L=80mm)	92LN-BAND1318A	2					
130		Rubber sheet	PGUMS0012AWZZ	1					
131		Mecha holder angle	LANGF0028AWZZ	1					
132		Change box	LCHSM0038AWZZ	1					
133		Center gear	NGERH0055AWZZ	1					
134		Center tray gear	NGERH0056AWZZ	3					
135		Tray drive gear	NGERH0058AWZZ	6					
136		Tray change lever	MLEVP0052AWZZ	3					
137		Top joint lever	MLEVP0053AWZZ	1					
138		Middle joint lever	MLEVP0054AWZZ	1					
139		Bottom joint lever	MLEVP0055AWZZ	1					
140		Motor Ass'y	RMOTV0373AFM1	1					
			for main cam						
141		Motor Ass'y	RMOTV0373AFM1	1					
			for tray						
142		Cam switch	QSW-F0353AFZZ	2					
143		Tray switch	QSW-P0920AFZZ	4					
201		Screw 2.6x4	XBPSD26P04000	4					
202		Screw 2x7	XEBSD20P07000	3					
203		Screw 2x6	XEBSD20P06000	3					
204		Screw 2.6x12	XEBSD26P12000	4					
205		Screw with washer 2.6x10	LX-EZ0005AWFD	4					

CD PLAYER SECTION

MEMO:

SCHEMATIC DIAGRAM (1/2)

1

2

3

4

5

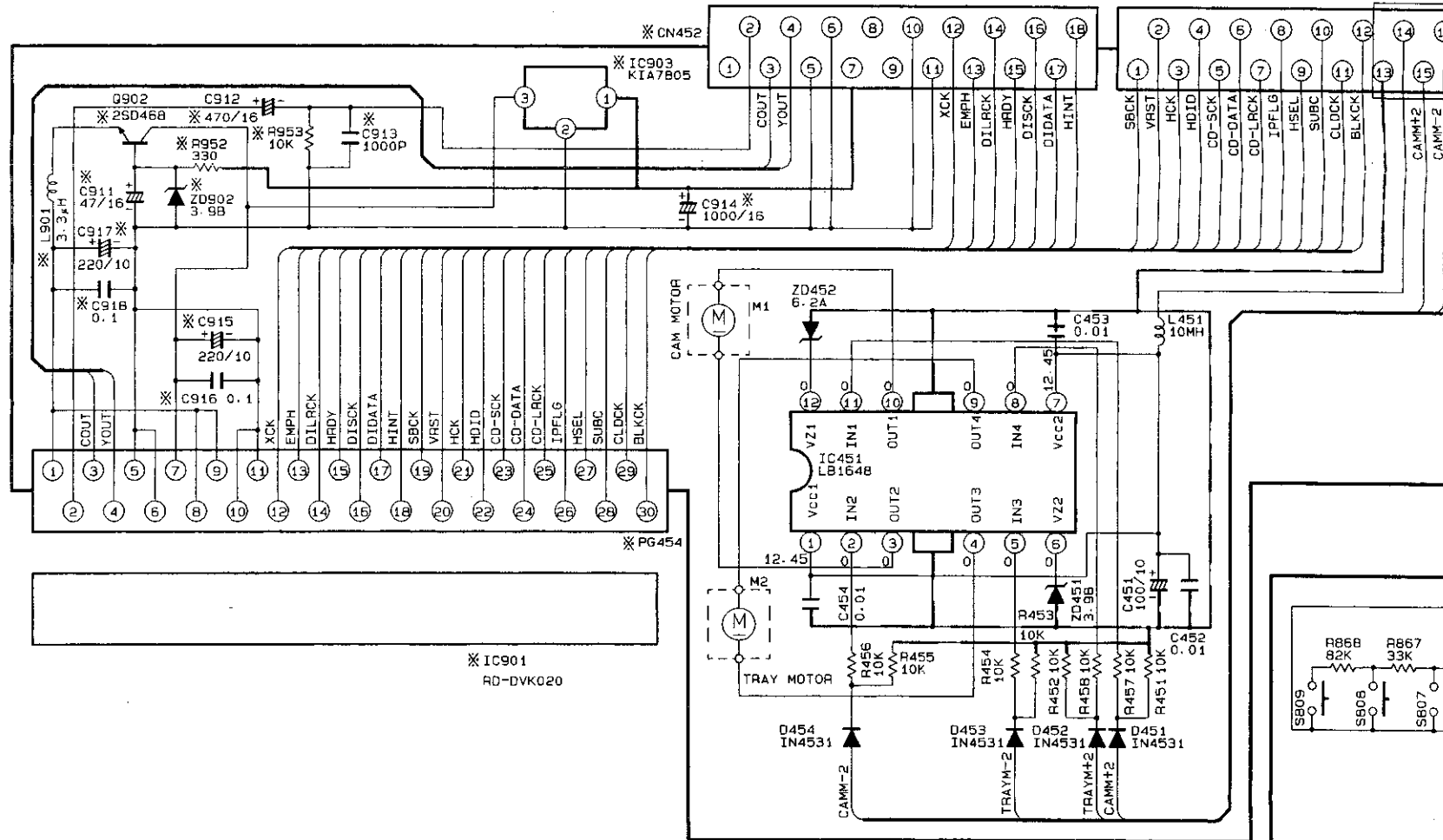

\* Only for E1-EA

NC  
AL  
EA  
CC  
CIF  
NC

7

8

9

10

11

A

B

C

D

E

F

G

H

N451 6P (for E3-E2-EK-J)

CN453 18P

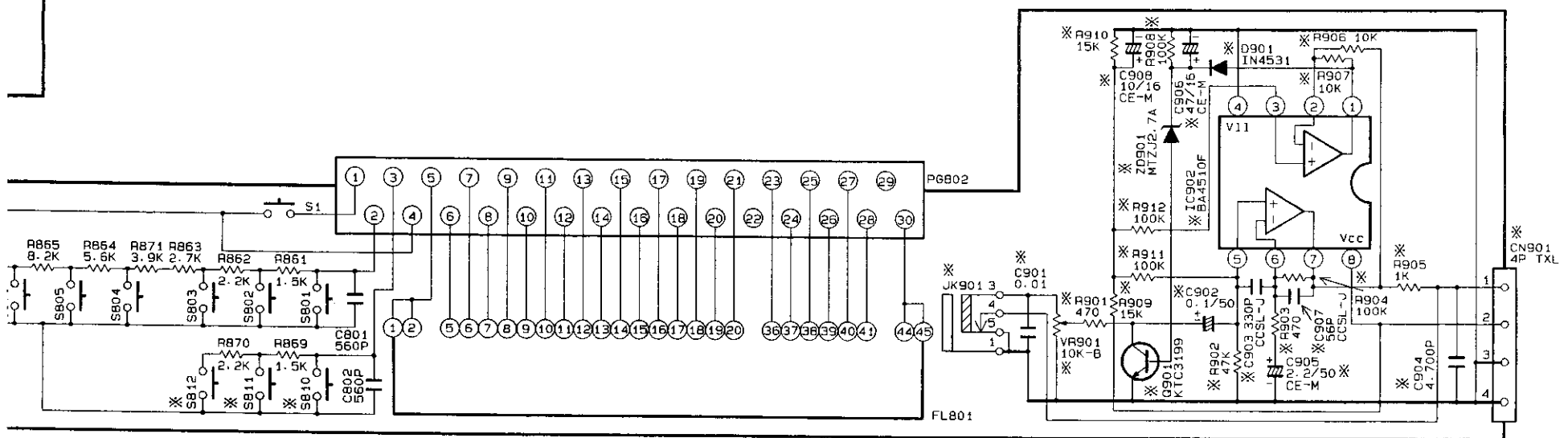

RESISTANCE VALUES IN OHM. k=1,000 OHM M=1,000,000 OHM  
 CAPACITANCE VALUES IN MICRO FARAD. P=MICRO-MICRO FARAD  
 VOLTAGE AND CURRENT ARE MEASURED AT NO SIGNAL INPUT  
 ON.  
 AND PARTS ARE SUBJECT TO CHANGE WITHOUT PRIOR

**WARNING:**

Parts marked with this symbol  have critical characteristics. Use ONLY replacement parts recommended by the manufacturer.

**CAUTION:**

Before returning the unit to the customer, make sure you make either (1) a leakage current check or (2) a line to chassis resistance check. If the leakage current exceeds 0.5 milliamps, or if the resistance from chassis to either side of the power cord is less than 240 kohms, the unit is defective.

**WARNING:**

DO NOT return the unit to the customer until the problem is located and corrected.

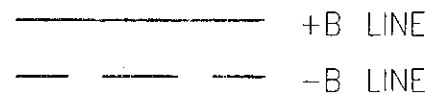



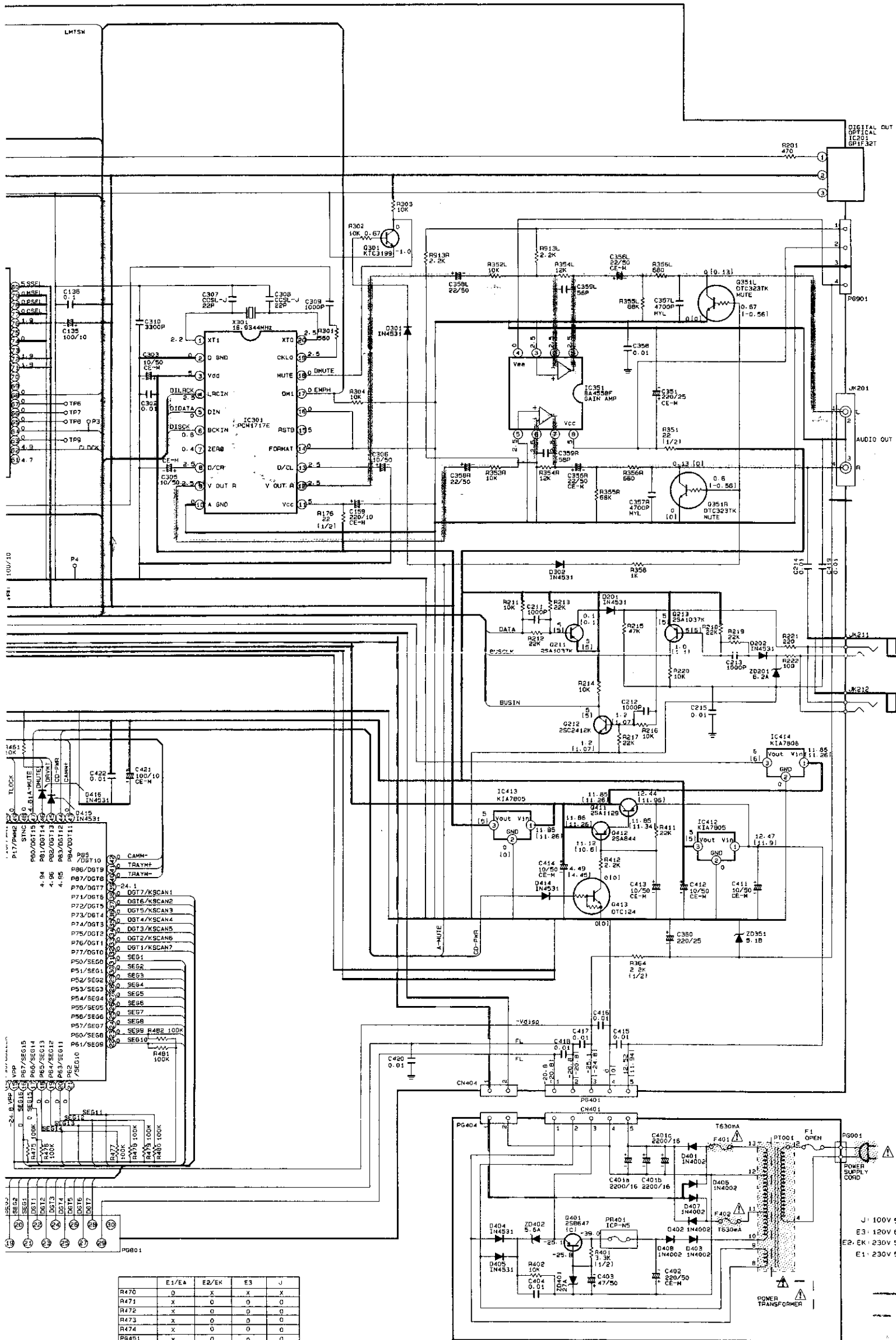

	E1/EA	E2/EK	E3	J
R470	0	X	X	X
R471	X	0	0	0
R472	X	0	0	0
R473	X	0	0	0
R474	X	0	0	0
R451	X	0	0	0
F401/402	T6300A	T6300A	B000A 250V	B000A 250V
PT001	BT00903	BT00903	BT00902	BT00901

J: 100V 50/60Hz  
 E3: 120V 60Hz  
 E2: EK: 230V 50Hz  
 E1: 230V 50/60Hz

# EXPLODED VIEW OF CD MECHANISM

## CD PLAYER SECTION

1      2      3      4      5      6      7      8

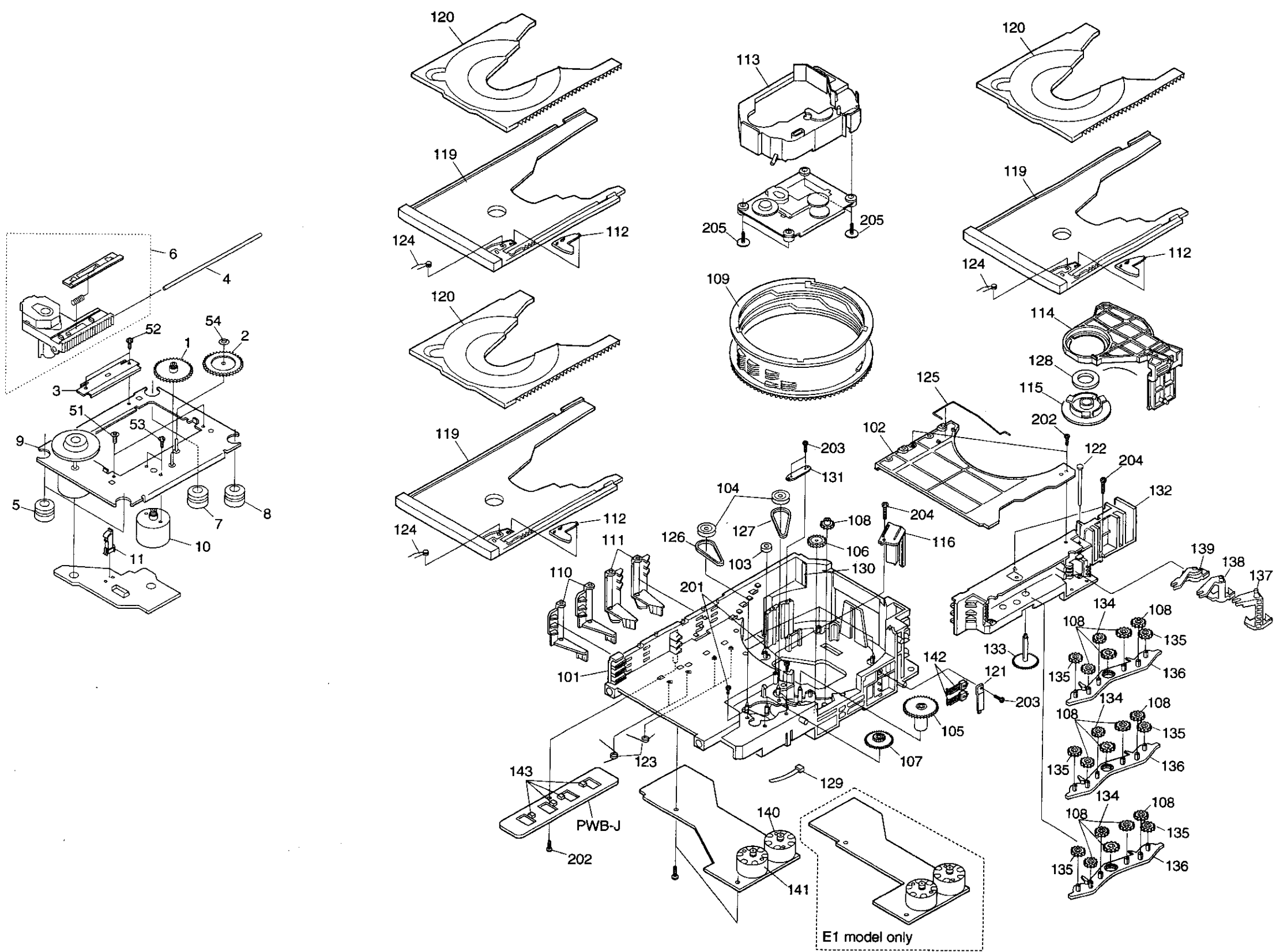

A  
B  
C  
D  
E

## COMPARATIVE PARTS LIST

## RECEIVER SECTION

ADDENDUM PARTS LIST OF EXPLODED VIEW  
UDRA-M7 (Receiver)

Ref No.	Part Name	Part No.			
		U.S.A./Canada Model	Europe Model	U.K. Model	Asia Model
14	Function button	9LP C022 61	9LP C022 61	9LP C022 61	9LP C022 62
15	Display button	9LP C022 81	9LP C022 81	9LP C022 81	9LP C022 82
16	Power button	9LP C022 91	9LP C022 91	9LP C022 91	9LP C022 92
17	Volume knob ass'y	9LP C023 01	9LP C023 01	9LP C023 01	9LP C023 02
18	Tone knob	9LP C023 31	9LP C023 31	9LP C023 31	9LP C023 32
22	Front panel (AL)	9LP M048 71	9LP M048 72	9LP M048 72	9LP M048 74

## CD PLAYER SECTION

ADDENDUM PARTS LIST OF EXPLODED VIEW  
UDCM-M7 (Compact Disc Player)

Ref No.	Part Name	Part No.			
		U.S.A./Canada Model	Europe Model	U.K. Model	Asia Model
15	Button (CD)	9LP C021 51	9LP C021 51	9LP C021 51	9LP C021 53
16	Button (P)	9LP C021 61	9LP C021 61	9LP C021 61	9LP C021 62
18	CD tray panel (1)	9LP H045 07	9LP H045 07	9LP H045 07	9LP H045 04
19	CD tray panel (2)	9LP H045 08	9LP H045 08	9LP H045 08	9LP H045 05
20	CD tray panel (3)	9LP H045 09	9LP H045 09	9LP H045 09	9LP H045 06
22	Front metal (CD)	9LP M048 01	9LP M048 01	9LP M048 01	9LP M048 03
28	Mic knob	—	—	—	9LP C021 72

## NIPPON COLUMBIA CO., LTD.

14-14, AKASAKA 4-CHOME, MINATO-KU, TOKYO 107-11 JAPAN  
 Telephone: 03 (3584) 8111  
 Cable: NIPPON COLUMBIA TOKYO Telex: JAPANOLA J22591