

HA 2032

# SERVICE MANUAL

# PARTS LIST



AKAI STEREO TAPE RECORDER

MODEL **GX-280**

ALSO APPLICABLE TO MODEL GX-280D

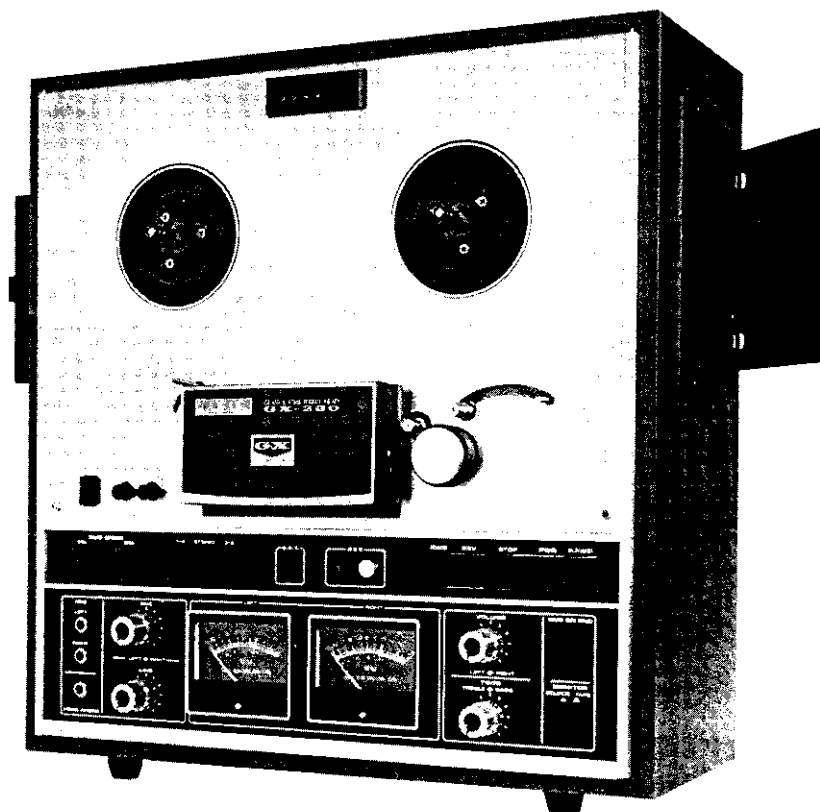

## STEREO TAPE RECORDER

MODEL GX-280

ALSO APPLICABLE TO MODEL GX-280D  
STEREO TAPE DECK

SECTION 1	SERVICE MANUAL .....	3
SECTION 2	PARTS LIST .....	35
SECTION 3	SCHEMATIC DIAGRAM .....	64

---

SECTION 1

**SERVICE MANUAL**

TABLE OF CONTENTS

I.	SPECIFICATIONS .....	4
II.	MEASURING METHOD .....	6
	1. TAPE SPEED DEVIATION .....	6
	2. WOW AND FLUTTER .....	6
	3. FREQUENCY RESPONSE .....	6
	4. SIGNAL TO NOISE RATIO .....	6
	5. TOTAL HARMONIC DISTORTION .....	7
	6. CROSS TALK .....	7
	7. ERASE RATIO .....	7
	8. POWER OUTPUT .....	7
III.	DISMANTLING OF UNIT .....	8
IV.	MECHANISM ADJUSTMENTS .....	10
	1. TAPE SPEED ADJUSTMENT (Servo-Control Amp. Adjustment) .....	10
	2. DIRECT FUNCTION TIME CONSTANT ADJUSTMENT .....	10
	3. BRAKE TENSION ADJUSTMENT .....	11
	4. SUPPLY VOLTAGE TO BOTH TORQUE MOTORS AS WELL AS TENSION AT VARIOUS OPERATING MODES .....	12
	5. REEL TABLE HEIGHT ADJUSTMENT .....	12
	6. PINCH WHEEL PRESSURE MEASUREMENT AND ADJUSTMENT .....	13
V.	HEAD ADJUSTMENTS .....	14
	1. HEAD HEIGHT ADJUSTMENT .....	14
	2. HEAD AZIMUTH ALIGNMENT ADJUSTMENT .....	15
VI.	AMPLIFIER ADJUSTMENTS .....	16
	1. PLAYBACK LEVEL ADJUSTMENT .....	17
	2. RECORDING LEVEL ADJUSTMENT .....	18
	3. RECORDING BIAS VOLTAGE ADJUSTMENT (Frequency Response Adjustment) .....	19
	4. RECORDING BIAS FREQUENCY MEASURING METHOD .....	19
VII.	TRANSPORT MECHANISM .....	20
	1. FROM STOP TO FORWARD PLAYBACK .....	22
	2. FROM FORWARD TO REVERSE PLAYBACK .....	22
	3. FROM REVERSE TO FORWARD PLAY .....	22
	4. FAST FORWARD .....	22
	5. REWIND .....	22
VIII.	SERVO MOTOR OPERATING PRINCIPLES .....	23
IX.	MOTOR AND COIL D.C. RESISTANCE .....	28
	1. SERVO MOTOR AND PICK UP COIL .....	28
	2. TORQUE MOTOR .....	28
	3. OTHER PARTS .....	29
X.	COMPOSITE VIEWS OF COMPONENTS .....	30

# I. SPECIFICATIONS

An asterisk next to a figure indicates the minimum guaranteed performance.

TRACK SYSTEM		4 track/2 channel stereo/monaural system
REEL CAPACITY		Up to 7" reel
TAPE SPEED		7-1/2 ips (19 cm/sec.) $\pm 0.5%$ (* $\pm 0.5%$ ) 3-3/4 ips (9.5 cm/sec.) $\pm 0.5%$ (* $\pm 1.0%$ )
WOW AND FLUTTER		Less than 0.08%(*0.12%) R.M.S. at 7-1/2 ips Less than 0.12%(*0.18%) R.M.S. at 3-3/4 ips
FREQUENCY RESPONSE	S.R.T. Tape  Standard Tape	30 to 26,000 Hz $\pm 3$ dB at 7-1/2 ips 30 to 22,000 Hz $\pm 3$ dB at 3-3/4 ips 30 to 24,000 Hz (*30 to 22,000 Hz) $\pm 3$ dB at 7-1/2 ips 30 to 19,000 Hz (*30 to 18,000 Hz) $\pm 3$ dB at 3-3/4 ips
SIGNAL TO NOISE RATIO		Better than 50 dB *Better than 48 dB at 7-1/2 ips *Better than 46 dB at 3-3/4 ips
DISTORTION FACTOR		Less than 1.5% at 1,000 Hz "0" VU recording *Less than 2% at 7-1/2 ips 1,000 Hz "O" VU recording *Less than 3% at 3-3/4 ips 1,000 Hz "O" VU recording
CROSS TALK		Better than 70 dB(*60 dB) monaural Better than 50 dB(*43 dB) stereo
ERASE RATIO		Better than 70 dB
BIAS FREQUENCY		100 to 110 kHz
BIAS LEAK		Less than -20 VU
HIGH FREQUENCY DEVIATION	Between Channels Between FWD/REV	Within 2 dB, using an 8,000 Hz 3-3/4 ips recorded tape at 7-1/2 ips Within 3 dB, using an 8,000 Hz 3-3/4 ips recorded tape at 7-1/2 ips
RECORDING/PLAYBACK LEVEL		"0" VU $\pm 1.5$ dB
INPUTS	Mic Input Line Input	0.8 mV Impedance: 10 k $\Omega$ 150 mV Impedance: 150 k $\Omega$ 12 mV(low), 75 mV(high) Impedance: 68 k $\Omega$
OUTPUTS	Line Output Din Output Power Output	1.228V (4 $\pm 1.5$ dB) 0.4V 20W continuous power at 8 $\Omega$ (GX-280 only) *10W when operating 1 channel at 8 $\Omega$ (GX-280 only) *5W at 8 $\Omega$ distortion less than 0.5% (GX-280 only)
HUM AND NOISE		Less than 3 mV at 8 $\Omega$ VR min, Tone flat (GX-280 only)
TONE CONTROL	Bass Treble	14 $\pm 2$ dB, -11 $\pm 2$ dB at 100 Hz 15 $\pm 2$ dB, -14 $\pm 2$ dB at 10,000 Hz
RECORDING CAPACITY		60 min. stereo recording, using a 1,200 ft. tape at 7-1/2 ips (19 cm/sec.)
FAST FORWARD AND REWIND TIME		64/80 sec., using a 1,200 ft. tape at 60/50 Hz
MOTORS	Capstan Motor  Reel Motor	2-speed servo control outer rotor motor Type: SCM2-24 Revolutions: 520 r.p.m. at 7-1/2 ips (19 cm/sec.) 260 r.p.m. at 3-3/4 ips (9.5 cm/sec.)  Two 6-pole eddy current outer rotor motors Type: 24XO-MR Revolutions: 930 r.p.m. at 50Hz 1,120 r.p.m. at 60 Hz
HEADS	Erase Head  Recording Head  Playback Head	Type: E4-250 Gap: 0.6mm Impedance: 195 $\Omega$ $\pm 10%$ at 100 kHz D.C. Resistance: 3.5 $\Omega$  Type: R4-200 Gap: 4 $\mu$ $\pm 15%$ Impedance: 1,870 $\Omega$ at 100 kHz D.C. Resistance: 8 $\Omega$  Type: P4-200 Gap: 1.75 $\Omega$ $\pm 15%$ Impedance: 3 $\pm 1$ k $\Omega$ at 1 kHz D.C. Resistance: 500 $\Omega$

TRANSISTORS	2SA564(R) ... 2 2SC458LG(B)(C) ... 2 2SC711(D)(E) ... 7 2SC871(E)(F) ... 8 2SC945(Q)(R)(S) ... 11	2SC968(3)(4) ... 7 2SC971(2)(3)RED ... 2 2SC1014(D)(E) ... 1 2SD234(Y) ... 2
I.C.	LD-3141 ... 2	EHD-AP4153P ... 2(GX-280 only)
DIODES	1N34A ... 13 10D1 ... 13 10D4 ... 2 YZ-088A ... 1	10DC1 (BLK) ... 1 10DC1 (RED) ... 1 S-15-01 ... 4(GX-280 only)
THERMISTER	41D26 ... 1	
POWER SUPPLY	100 to 240V A.C., 50/60 Hz	
POWER CONSUMPTION	160W (GX-280) 130W (GX-280D)	
INSULATION RESISTANCE	More than 50 M $\Omega$	
INSULATION DURABILITY	500V D.C. for more than 1 min. duration	
DIMENSIONS	445(W) x 465(H) x 237(D) mm (17.8" x 18.6" x 9.5") (GX-280) 435(W) x 465(H) x 237(D) mm (17.4" x 18.6" x 9.5") (GX-280D)	
WEIGHT	23 kg (51 lbs.) (GX-280) 21 kg (46 lbs.) (GX-280D)	

NOTE: Specifications subject to change without notice.

## II. MEASURING METHOD

### 1. TAPE SPEED DEVIATION

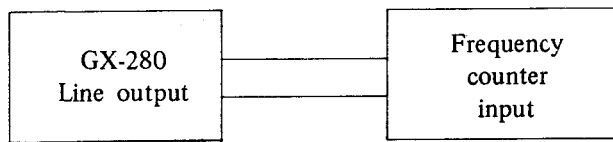

Fig. 1

As shown in Fig. 1, connect a Frequency Counter to the Line Output of Model GX-280. Playback a 1,000 Hz pre-recorded test tape. Take a Frequency Counter reading at the beginning, middle, and end of tape winding during playback. The maximum value of these respective readings will represent tape speed deviation.

### 2. WOW AND FLUTTER



Fig. 2

#### Method A

As shown in Fig. 2, connect the Line Output of Model GX-280 to the Input of a Wow and Flutter Meter. Playback a 3,000 Hz pre-recorded test tape and take a Wow and Flutter Meter reading at the beginning, middle, and end of tape winding. The maximum value of these respective readings will represent the Wow and Flutter.

#### Method B

Supply a 3,000 Hz sine wave signal from an Audio Frequency Oscillator and make a recording on a blank tape at the beginning, middle, and end of tape winding. Rewind and playback the resultant signal. Measure Wow and Flutter with a Wow and Flutter Meter. (The Wow and Flutter value of Method B will be close to twice that of Method A.)

### 3. FREQUENCY RESPONSE

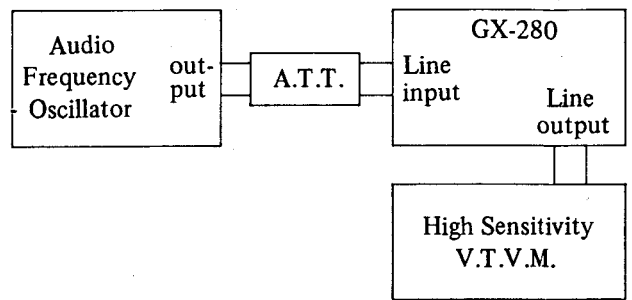

Fig. 3

For measuring Frequency Response, connect instruments as shown in Fig. 3 and proceed as follows:

- 1) Supply a 1,000 Hz sine wave signal to the Line Input of Model GX-280 from an Audio Frequency Oscillator through an Attenuator.
- 2) Set recorder to recording mode and turn recording level control volume and line output level control volume to maximum. Adjust attenuator to obtain a +4 dB V.T.V.M. reading.
- 3) Under conditions described in 2) above, readjust attenuator so that the Line Output is -16 dB, and record 30 to 24,000 Hz spot frequencies.
- 4) Rewind tape and playback from the beginning. Take V.T.V.M. spot frequency readings and plot values on a graph.

NOTE: When measuring Frequency Response, new tape should be used.

### 4. SIGNAL TO NOISE RATIO

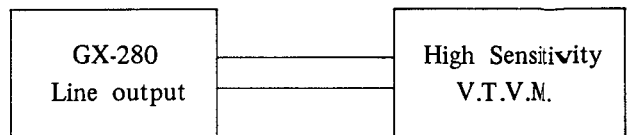

Fig. 4

As shown in Fig. 4, connect a High Sensitivity V.T.V.M. to the Line output of Model GX-280. Playback a 250 Hz "0" VU pre-recorded test tape and measure the output. Then remove the tape and measure the noise level under the same condition. Convert each of the measured values into decibels.

## 5. TOTAL HARMONIC DISTORTION

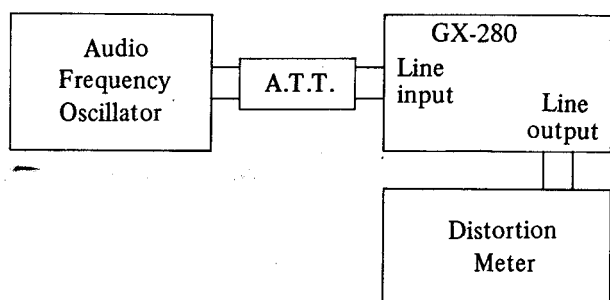

Fig. 5

Connect the measuring instruments as shown in Fig. 5 and record a 1,000 Hz sine wave signal at "0" VU. Playback the resultant signal and measure the overall distortion factor. Measure the noise level of the tape recorder without the tape. Connect the Audio Frequency Oscillator directly to the distortion meter for measurement of the distortion factor of the oscillator. The required distortion factor can be obtained from the results of the above measurement by the following formula:

$$d_0 = d - d_1 - d_2.$$

where,  $d_0$  = Required distortion factor  
 $d$  = Overall distortion factor  
 $d_1$  = Noise level  
 $d_2$  = Distortion factor of the oscillator

NOTE: When measuring the distortion factor, new tape should be used.

## 6. CROSS TALK (Cross talk between the tracks)

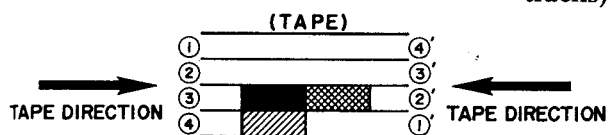

Fig. 6

As shown in Fig. 6, first record a 1,000 Hz sine wave signal on Track No. 3 at +3 VU level. Next, record under a non-input condition. Then, playback the tape on Tracks No. 3 and 1 (reversed condition of tape) through the B.P.F. (band pass filter sensitivity ... 1:1) and obtain a ratio between the two from the following formula:

$$C = 20 \log \frac{E_0}{E_2 - E_1} \text{ (dB)}$$

where,  $C$  = Desired cross talk ratio (dB)  
 $E_0$  = 1,000 Hz signal output level   
 $E_2$  = 1,000 Hz cross talk level   
 $E_1$  = Non-input signal recorded level

Fig. 7

## 7. ERASE RATIO

As shown in Fig. 3, connect a High Sensitivity V.T.V.M. to the Line Output of Model GX-280. Playback a virgin tape and take a V.T.V.M. reading of the output level. Next, record a 1,000 Hz sine wave signal at +3 VU, then playback this recorded signal and take a V.T.V.M. reading of the output level. Next, using this pre-recorded tape, record under a non-input condition and take a reading of the noise output level of the erased signal and obtain a ratio between the two from the following formula:

$$E_r = 20 \log \frac{E_0}{E_2 - E_1} \text{ (dB)}$$

where,  $E_r$  = Desired erase ratio (dB)  
 $E_0$  = 1,000 Hz signal output level  
 $E_2$  = Non-input signal recorded level  
 $E_1$  = Virgin tape noise output level

## 8. POWER OUTPUT (GX-280 only)

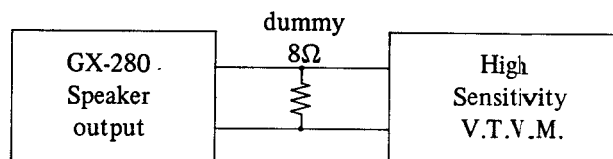

Fig. 8

As shown in Fig. 8, connect an 8Ω dummy load resistor to the speaker output and connect this terminal to a High Sensitivity V.T.V.M. Playback a 250 Hz "0" VU pre-recorded test tape and take a V.T.V.M. reading of the output level. The resultant output can be obtained from the above measurement by using the following formula:

$$P = \frac{E^2}{R} \text{ (W)}$$

where,  $P$  = Desired power output (watts)  
 $E$  = Measured voltage (R.M.S.)  
 $R$  = 8Ω

### III. DISMANTLING OF UNIT

In case of trouble, etc. necessitating disassembly, please disassemble in the order shown in photographs. Reassemble in reverse order.

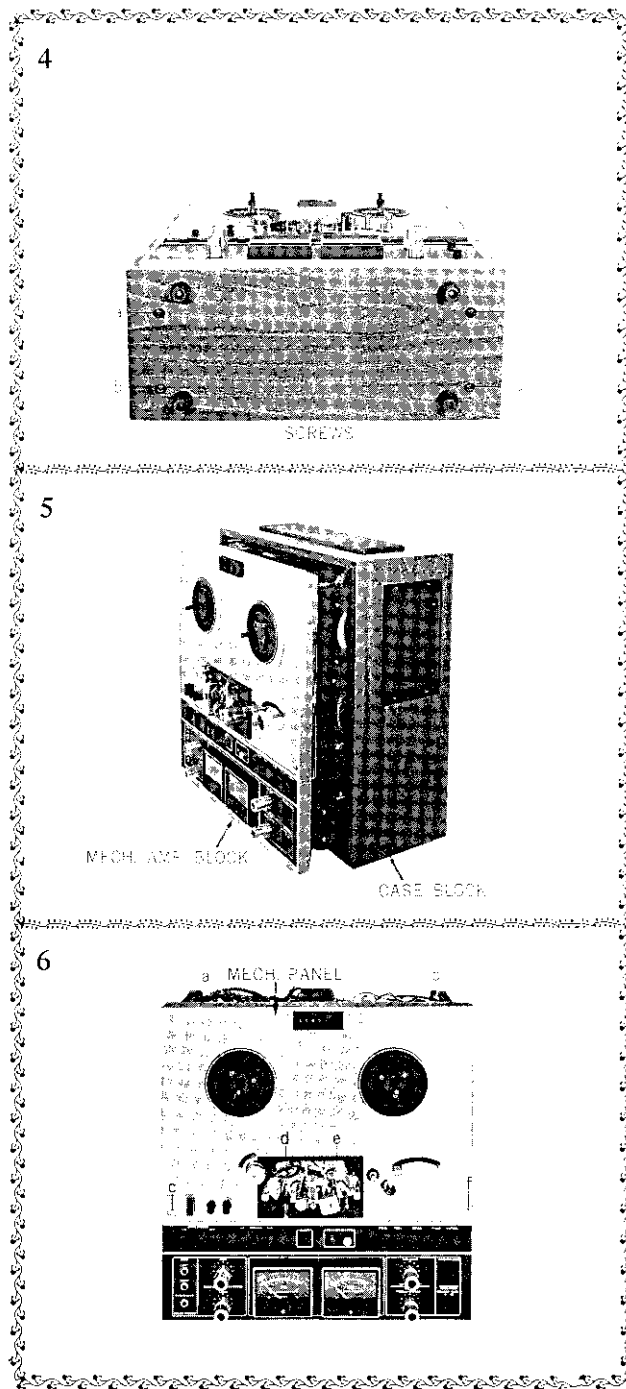
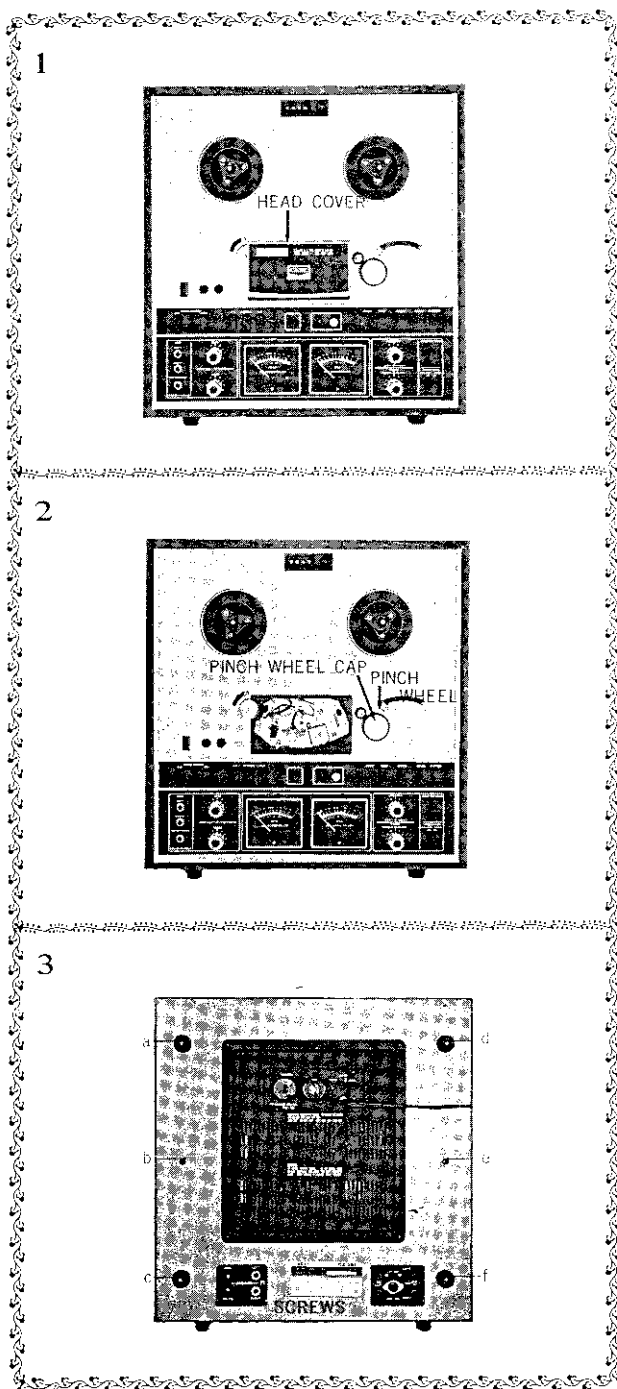



7

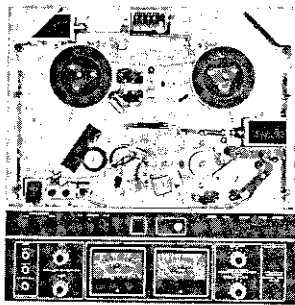

MECHANISM ADJUSTMENT

8

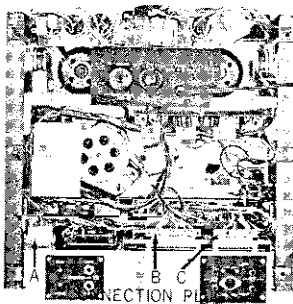

CONNECTION PL

9

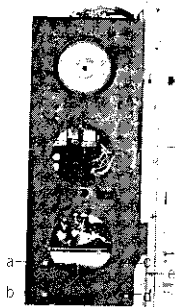

SCREWS

10



SCREWS

11

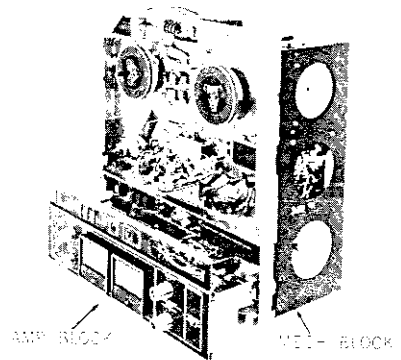

AMP BLOCK

MEL-BLOCK

12

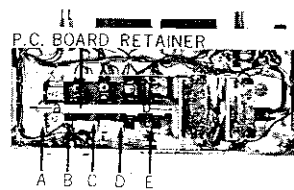

P.C. BOARD RETAINER

A B C D E

## IV. MECHANISM ADJUSTMENTS

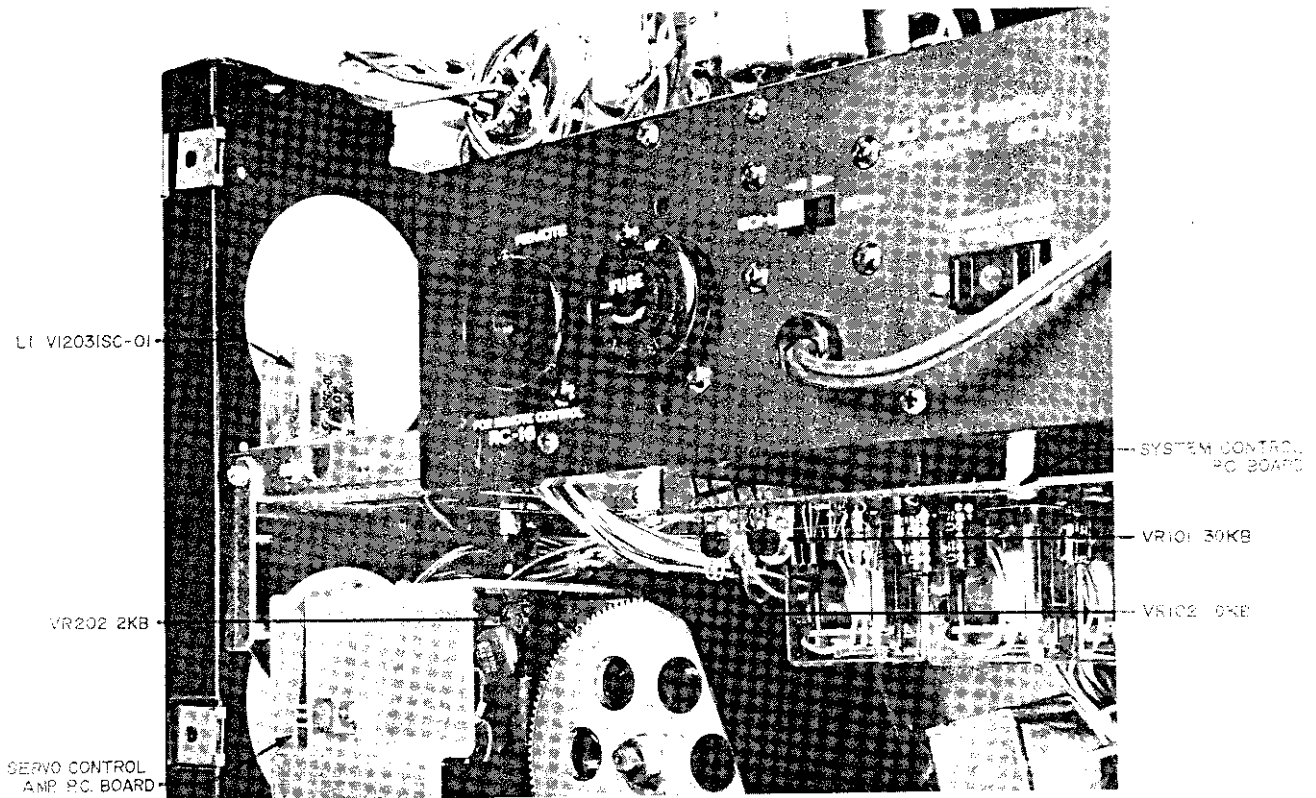

Fig. 9

### 1. TAPE SPEED ADJUSTMENT (Servo-Control Amp. Adjustment)

- 1) Connect a Frequency Counter to the line output terminals as shown in Fig. 1.
- 2) Turn Volume Controls to maximum and depress the 3-3/4 ips (9.5 cm/sec.) Tape Speed Selector. Playback a 1,000 Hz pre-recorded test tape.
- 3) Adjust the core of coil L1 (VI023SC-01) shown in Fig. 9 so that the Frequency Counter indication is 500 Hz  $\pm 1\%$ .
- 4) After the 3-3/4 ips (9.5 cm/sec.) tape speed adjustment has been completed, depress the 7-1/2 ips (19 cm/sec.) Tape Speed Selector and adjust Servo-Control P.C. Board semi-fixed resistor VR202 (2 kB) shown in Fig. 9 so that the frequency counter indication is 1,000 Hz  $+1/-0.5\%$ .

NOTE: When making tape speed adjustment, it is necessary to make the low speed (3-3/4 ips) adjustment first.

### 2. DIRECT FUNCTION TIME CONSTANT ADJUSTMENT

- 1) FWD  $\leftrightarrow$  REV Time Constant  
Adjust System Control P.C. Board semi-fixed resistor VR101 (30 kB) shown in Fig. 9 so that when the machine is switched from FWD to REV mode or from REV to FWD mode, the pinch wheel separates from the capstan in about 3 seconds.
- 2) Adjust System Control P.C. Board semi-fixed resistor VR102 (10 kB) shown in Fig. 9 so that when the machine is switched from F.FWD or RWD to FWD or REV mode, the time constant is about 1.5 seconds.

NOTE: When making adjustments outlined in 2 (1) and 2 (2) above, when the machine is switched from the various modes to FWD or REV, confirm that correct capstan motor (servo motor) revolutions are reached by the time the pinch wheel contacts the capstan.

### 3. BRAKE TENSION ADJUSTMENT

- 1) Use a 60 mm diameter tape wound on a 5" reel and measure the brake tension as shown in Fig. 10. Ideal tape tension is 350 grams.
- 2) Brake tension adjustment methods are as follows: (Refer to Fig. 11)
  - a. Change position of suspended springs (d) and (d').
  - b. Loosen screws (a) and (b) as well as (a') and (b') and adjust the vertical (up and down) position of spring suspension metals (c) and (c').
  - c. Loosen screws (e) and (f) as well as (e') and (f') and adjust the horizontal (left and right) position of brake band suspension metal (g) and (g').

NOTE: In making brake tension adjustment, confirm that when the machine is set to each of the various modes (except stop mode) the brake band completely separates from the cloth tape on the brake drum. (Refer to Fig. 12)

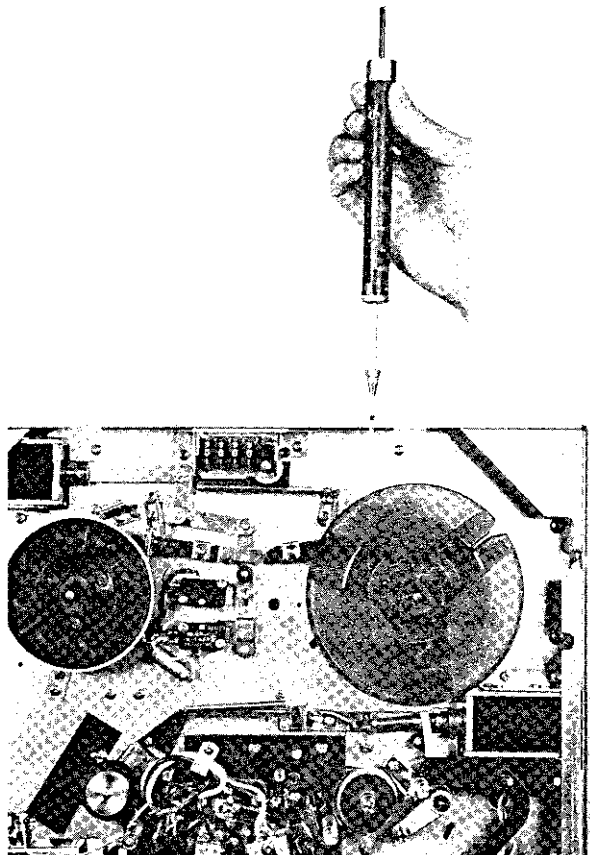

Fig. 10

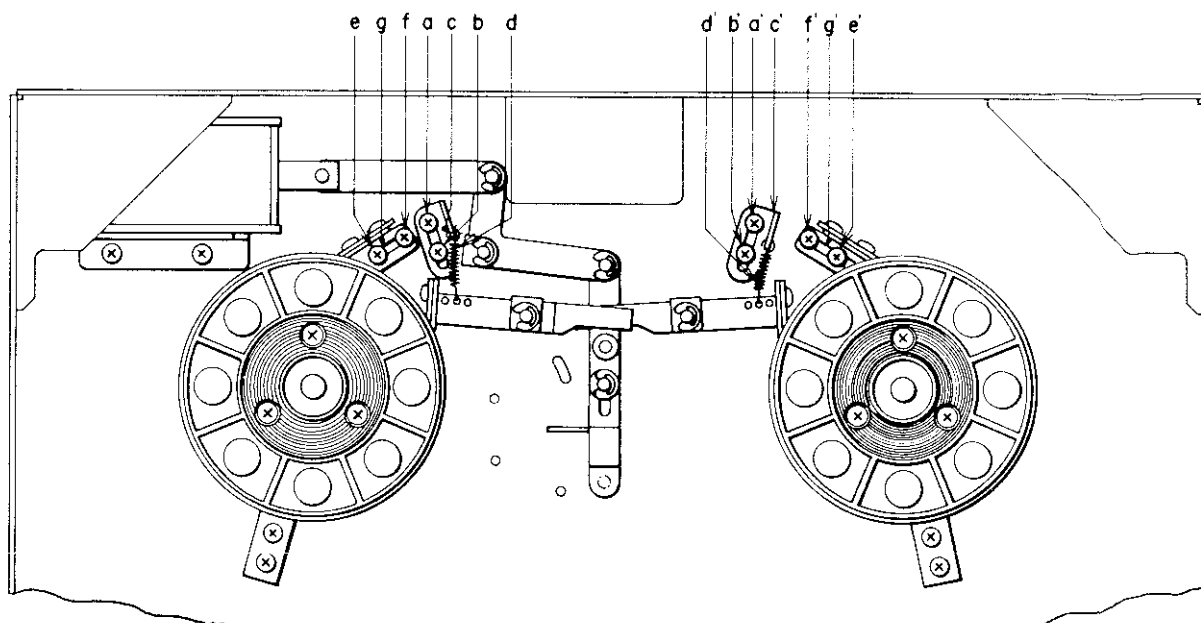

Fig. 11

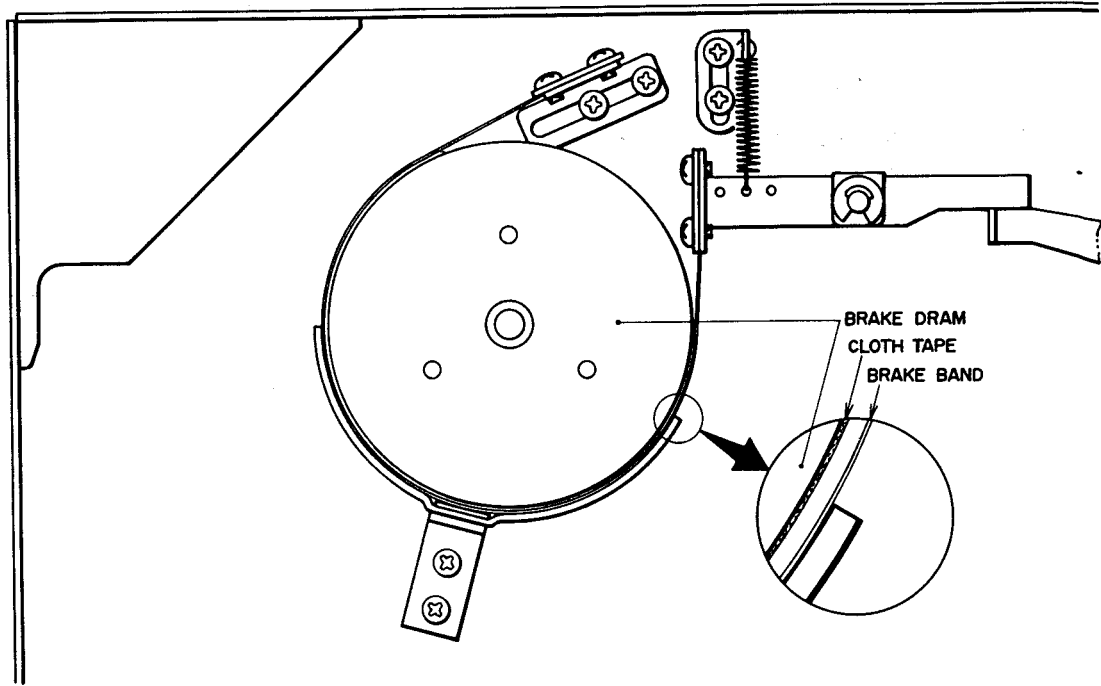

Fig. 12

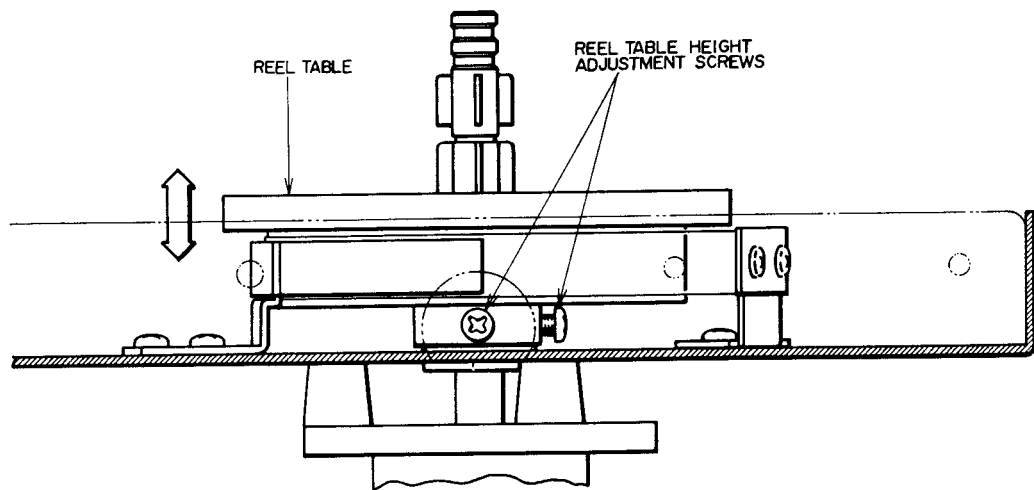

Fig. 13

#### 4. SUPPLY VOLTAGE TO BOTH TORQUE MOTORS AS WELL AS TENSION AT VARIOUS OPERATING MODES

Torque Motors	Left Side	Right Side
Modes		
FWD	30V (35V) 55g	55V (60V) 180g
REV	55V (60V) 180g	30V (35V) 55g
RWD	100V (100V) 500g	11V (13V) 15g
F.FWD	11V (13V) 15g	100V (100V) 500g

Figures in parenthesis indicate Voltage at 60 Hz.

Chart 1

#### 5. REEL TABLE HEIGHT ADJUSTMENT

Loosen the reel table height adjustment screws shown in Fig. 13 and adjust by moving the reel table as indicated by the arrow and positioning so that the tape winds in the center of the reel.

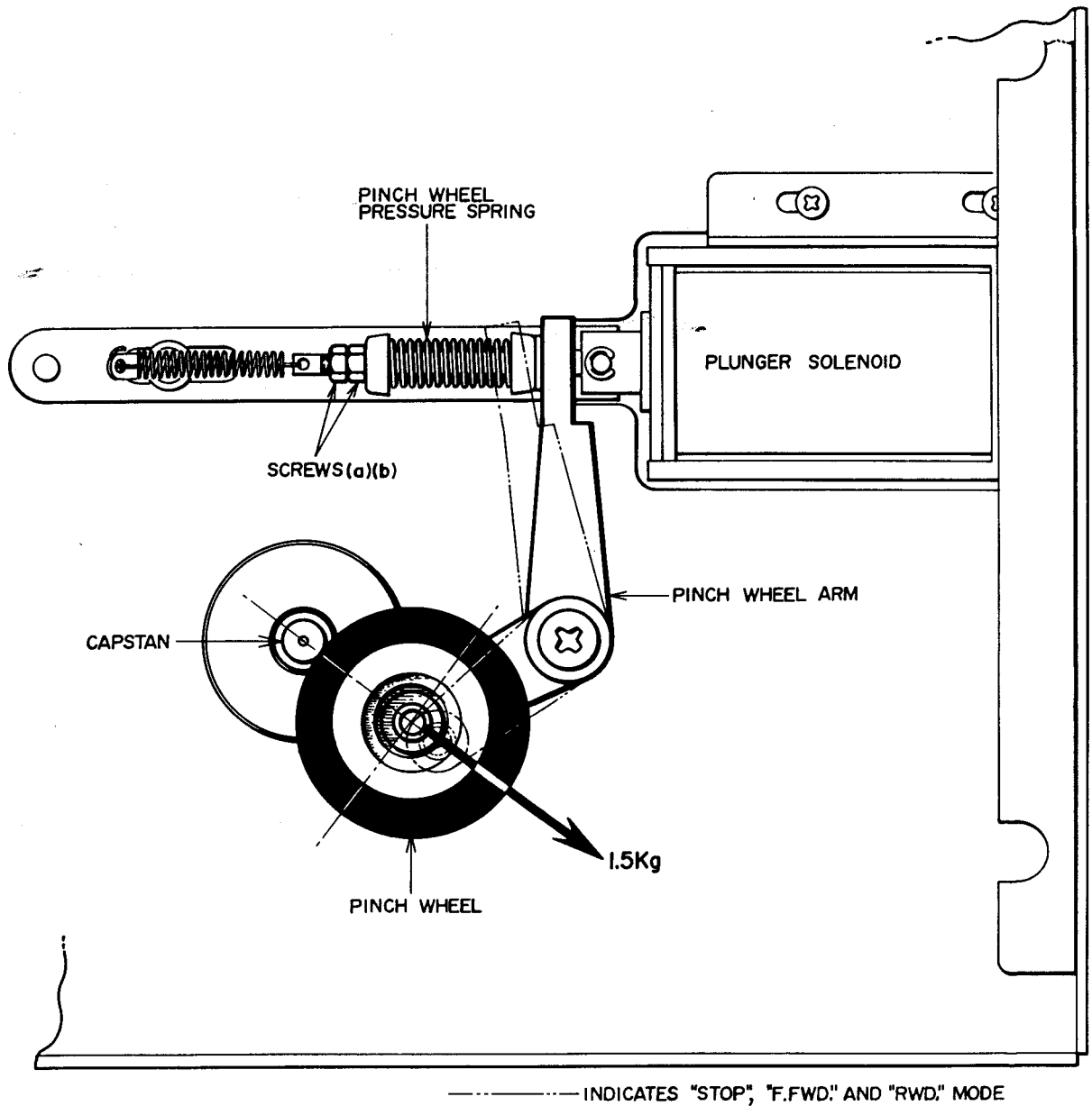

Fig. 14

## 6. PINCH WHEEL PRESSURE MEASUREMENT AND ADJUSTMENT

Use a tension gauge and measure the pinch wheel pressure as shown in Fig. 14. Read the value on the gauge as soon as the pinch wheel separates from the tape and tape travel stops. Ideal pinch wheel pressure is 1.5 kg. To regulate pinch wheel pressure, adjust nuts (a) and (b) shown in Fig. 14.

## V. HEAD ADJUSTMENTS

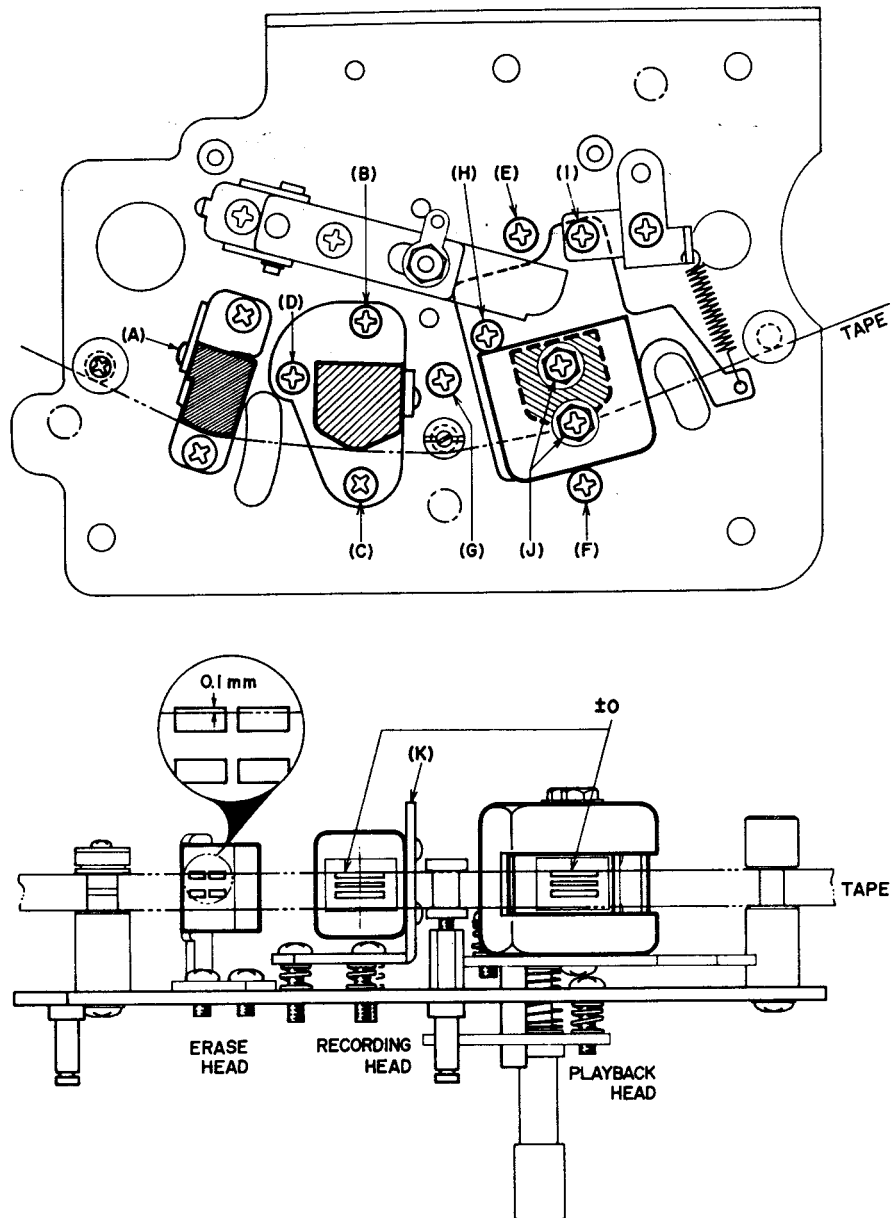

Fig. 15

### 1. HEAD HEIGHT ADJUSTMENT

#### 1) ERASE HEAD

At P.B. mode, loosen screw (A) shown in Fig. 15 and adjust erase head height so that the upper edge of the tape is about 0.1 mm lower than the left channel head core of the erase head.

#### 2) RECORDING HEAD

At P.B. mode, adjust recording head height by turning screws (B), (C), and (D) shown in Fig. 15 to left and right until the upper edge of the tape and the upper edge of the left channel head core of the recording head are the same height.

#### 3) PLAYBACK HEAD

- a. At forward P.B. mode, adjust playback head height by turning screw (I) shown in Fig. 15 to left and right until the upper edge of the tape and the upper edge of the left channel head core of the playback head are the same height.
- b. At reverse P.B. mode, adjust playback head height by turning screw (H) shown in Fig. 15 to left and right until the lower edge of the tape and the lower edge of the right channel head core of the playback head are the same height.

---

## 2. HEAD AZIMUTH ALIGNMENT ADJUSTMENT

### 1) PLAYBACK HEAD

- a. Connect a high sensitivity V.T.V.M. to the line output terminals.
- b. Depress the 7-1/2 ips Tape Speed Switch. Then turn Volume Controls to maximum and depress the STEREO Track Selector.
- c. Playback an 8,000 Hz at 3-3/4 ips Ampex Alignment test tape.
- d. At forward P.B. mode, turn azimuth alignment adjustment screw (G) to left and right until the output level of both channels is maximum.
- e. After the adjustment outlined in (d) above has been completed, loosen screws (J) and move the head gap side of the playback head to left and right until there is no fluctuation (maximum allowable fluctuation +0.5/-0 dB) in output level (both channels) when tension is applied to the supply reel. Tighten screws (J) to maintain this condition.
- f. At reverse P.B. mode, make the same adjustment as outlined in (e) above.

### 2) RECORDING HEAD

- a. Connect an Audio Frequency Oscillator to the line input terminals and a high sensitivity V.T.V.M. to the line output terminals and load a blank tape.
- b. Set the Monitor Switch to TAPE position and record a 16,000 Hz signal at -10 dB.
- c. At recording mode, turn azimuth alignment screw (D) to left and right and adjust so that the line output level of both channels is maximum and does not fluctuate.
- d. When the above adjustment has been completed, adjust the gap side of the recording head by bending recording head installation angle (K) shown in Fig. 15 to left and right until the line output level (both channels) does not fluctuate (maximum allowable fluctuation +0.5/-0 dB) when tension is applied to the supply reel.

3. For optimum adjustment, repeat Items 1) and 2) above 2 or 3 times. Blank test tape should be new tape.

## VI. AMPLIFIER ADJUSTMENTS

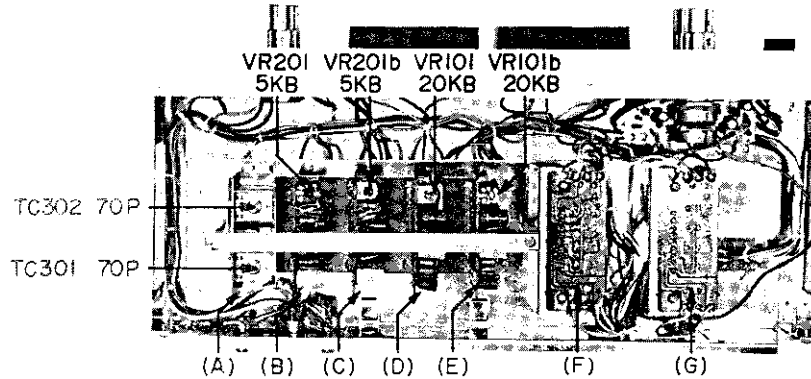

Fig. 16

- (A) . . . OSCILLATOR P.C. BOARD KD-A5004
- (B) . . . LEFT ch. RECORDING AMP. P.C. BOARD KD-A5011
- (C) . . . RIGHT ch. RECORDING AMP. P.C. BOARD KD-A5011
- (D) . . . LEFT ch. PLAYBACK AMP. P.C. BOARD KD-A5010
- (E) . . . RIGHT ch. PLAYBACK AMP. P.C. BOARD KD-A5010
- (F) . . . LEFT ch. POWER AMP. P.C. BOARD KD-A5015
- (G) . . . RIGHT ch. POWER AMP. P.C. BOARD KD-A5015

NOTE: Power Amp. P.C. Board included in Model GX-280 only.

### 1. PLAYBACK LEVEL ADJUSTMENT

(See Figs. 17 to 19)

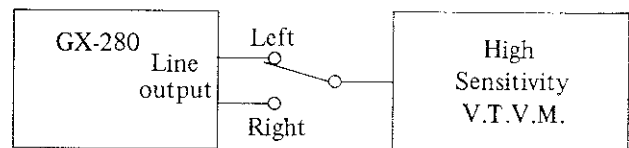

Fig. 17

- 1) Connect a High Sensitivity V.T.V.M. to the Line output terminals.
- 2) Depress the 7-1/2 ips Tape Speed Switch, turn the Volume controls to maximum, set SND ON SND Switch to OFF and the Monitor Switch to TAPE position, and depress the STEREO Track Selector.
- 3) Playback a 250 Hz "0" VU recorded test tape.
- 4) Adjust the Playback Amp. P.C. Board playback level adjustment semi-fixed resistor VR101 50 k $\Omega$  (left ch.) and VR101b 50 k $\Omega$  (right ch.) shown in Fig. 16 so that the High Sensitivity V.T.V.M. indication is 4 dB (1.228V).





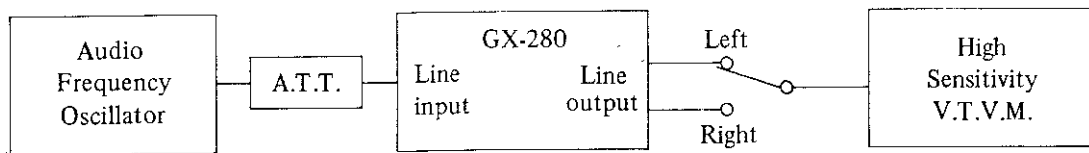

Fig. 20

## 2. RECORDING LEVEL ADJUSTMENT (See Figs. 20, 21 & 22)

TR 201, 202 25C871 (E) (F) or 25C458L6 (C)  
 TR 203 25C458 LG (D) (E)  
 TR 204 25C711 (D) (E) or 25C536 (E) (F)  
 TR 205 25C968 (A)

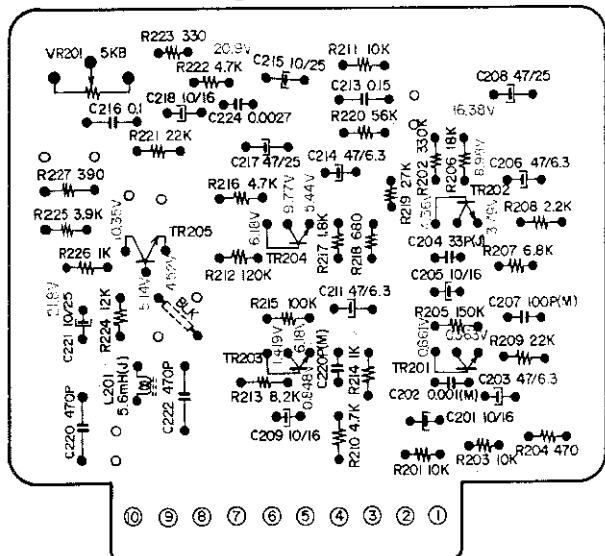

Fig. 21 RECORDING AMP. P.C. BOARD KD-A5011  
(Reverse Side)

- 1) Connect an Audio Frequency Oscillator to the Line input terminals through an Attenuator and connect a High Sensitivity V.T.V.M. to the Line output terminals.
- 2) Depress the 7-1/2 ips Tape Speed Switch, set Line Recording level controls and Volume controls to maximum, set SND ON SND Switch to OFF position and depress the STEREO Track Selector.
- 3) Set Monitor Switch to TAPE position, set S.R.T. Switch to OFF position, and load a FUJI S-100 blank tape.
- 4) Set recorder to recording mode and supply a 1,000 Hz signal from the Audio Frequency Oscillator. Adjust the Attenuator to obtain a V.T.V.M. indication of 4 dB (1.228V).
- 5) Set the Monitor Switch to SOURCE position and adjust Recording Amp. P.C. Board recording level adjustment semi-fixed resistors VR201 5 kΩ (left ch.) and VR201b 5 kΩ (right ch.) shown in Fig. 16 to obtain a Line output level of 4 dB.

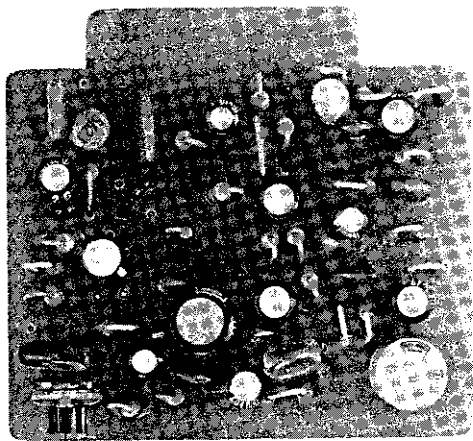

Fig. 22 RECORDING AMP. P.C. BOARD  
KD-A5011 (Face Side)

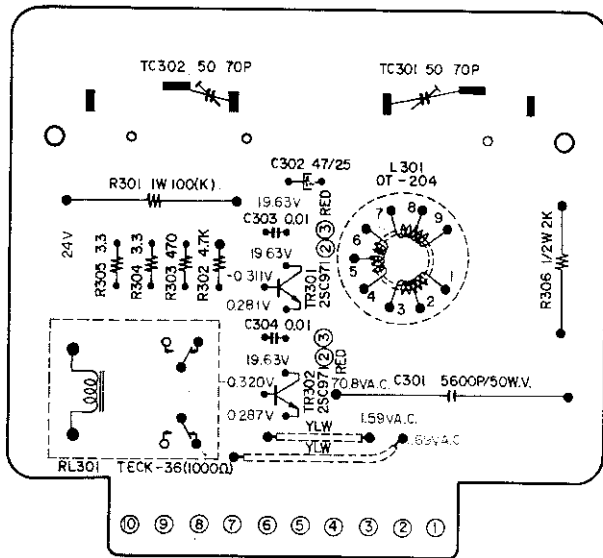

Fig. 23 OSCILLATOR P.C. BOARD KD-A5004 (Reverse Side)

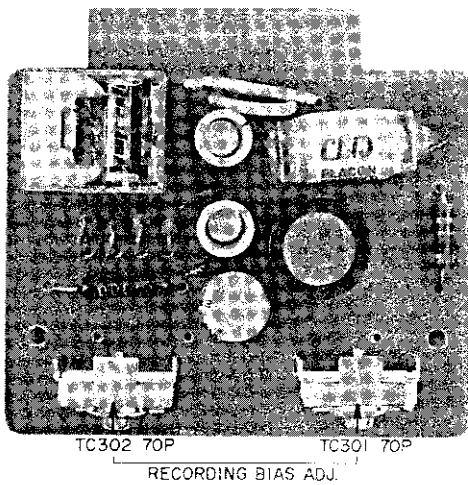

Fig. 24 OSCILLATOR P.C. BOARD KD-A5004 (Face Side)

### 3. FREQUENCY RESPONSE ADJUSTMENT (See Figs. 23 & 24)

- 1) Connect the various measuring instruments as outlined in "Recording Level Adjustment" procedure.
- 2) Following "Recording Level Adjustment" procedure through Item 4) and set the Attenuator to  $-20$  dB.
- 3) Under these conditions, adjust OSC. P.C. Board frequency response adjustment trimmer condensers TC301 70P (left ch.) and TC302 70P (right ch.) shown in Fig. 16 to obtain an equally flat frequency response at 1,000 Hz and 10,000 Hz.
- 4) Following Frequency Response adjustment, the Recording bias voltage is 1.55 to 1.7V A.C.

NOTE: The frequency response will vary depending upon the tape being used. (As a general rule, FUJI S-100 tape is used.) Erase Voltage is 70V A.C.

### 4. RECORDING BIAS FREQUENCY MEASURING METHOD

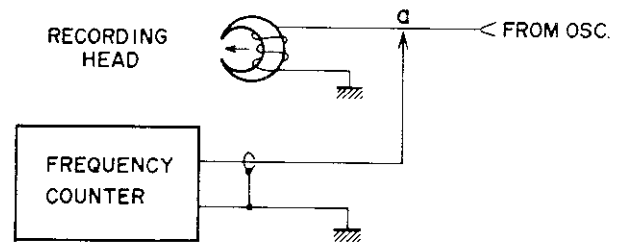
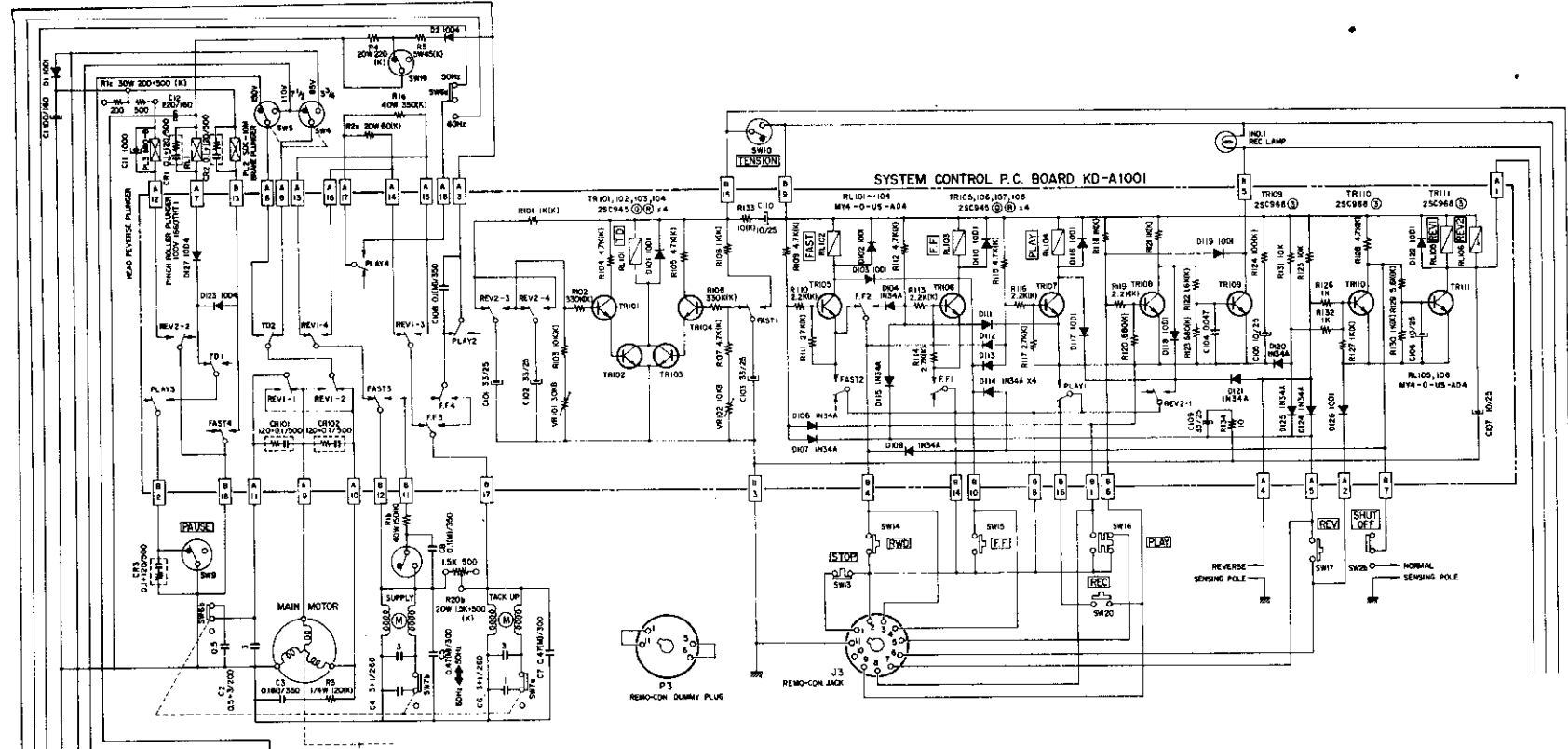

Fig. 25

- 1) As shown in Fig. 25, connect a Frequency Counter to Terminal (a) as well as the GROUND. Then set recorder to recording mode and take a Frequency Counter reading.
- 2) Correct recording bias frequency is 100 to 110 kHz.



TRANSISTOR, RELAY, AND PLUNGER SOLENOID OPERATION CHART

FUNCTION	TRANSISTORS											RELAYS						PLUNGER SOLENOIDS			
	TR101	TR102	TR103	TR104	TR105	TR106	TR107	TR108	TR109	TR110	TR111	T.D. RL101	FAST RL102	F.F. RL103	PLAY RL104	REV1 RL105	REV2 RL106	PINCH WHEEL PL1	BRAKE PL2	HEAD REV PL3	
RWD					○			○				△	○						○		
REV									○			△				○			○		○
STOP								○													
FWD												△	○			○	○				
FWD REC.															○				○		

○ MARK INDICATES "ENGAGED"  
 △ MARK INDICATES "MOMENTARILY ENGAGED"

SYSTEM CONTROL SCHEMATIC DIAGRAM

SCHEMATIC-1

Fig. 26 SYSTEM CONTROL P.C. BOARD KD-A1001 (Reverse Side)

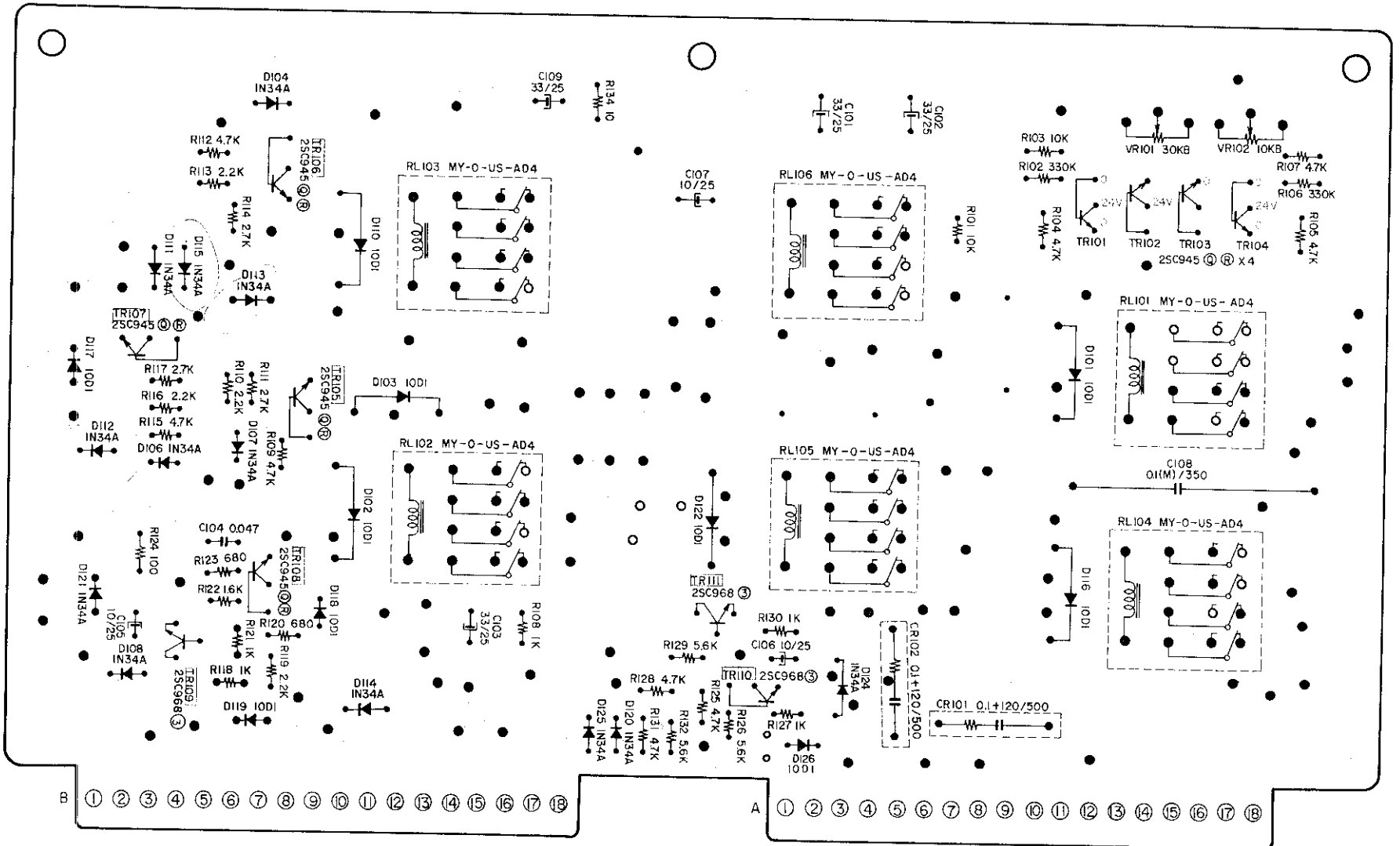

	TR105			TR106			TR107			TR108			TR109			TR110		
	E	B	C	E	B	C	E	B	C	E	B	C	E	B	C	E	B	C
1. TR105	25V	4V	4V	25V	4V	4V	25V	4V	4V	25V	4V	4V	25V	4V	4V	25V	4V	4V
2. TR106	25V	4V	4V	25V	4V	4V	25V	4V	4V	25V	4V	4V	25V	4V	4V	25V	4V	4V
3. TR107	25V	4V	4V	25V	4V	4V	25V	4V	4V	25V	4V	4V	25V	4V	4V	25V	4V	4V
4. F.F.	0.017V	0.108V	0.795V	0.101V	0.799V	0.203V	0.24V	0.657V	0.202V	0.20V	0.203V	0.24V	0.233V	0.016V	0.028V	0.776V	0.0017V	0.24V
5. RW0	0.012V	0.101V	0.786V	0.624V	0.24V	0.203V	0.20V	0.657V	0.202V	0.20V	0.203V	0.24V	0.233V	0.016V	0.028V	0.776V	0.0017V	0.24V
6. REC.	0.25V	0.24V	3.50V	0.775V	0.24V	0.203V	0.20V	0.657V	0.202V	0.20V	0.203V	0.24V	0.233V	0.016V	0.028V	0.776V	0.0017V	0.24V

---

## 1. FROM STOP TO FORWARD PLAYBACK

When the FWD Button is depressed TR107 emitter is grounded, and TR107 passes RL104 and is turned on. TR107 is maintained at "ON" by RL104 contact point Play-1.

The Pinch Roller Plunger and Brake Plunger current passes Play-3 and is turned on. The voltage passes Play-4 and is divided by means of R1a (350Ω) and R2a (60 Ω). About 55V (60V 60Hz) is supplied to the Take-up Motor and about 30V(35V 60 Hz) to the Supply Motor. At 7-1/2 ips. 110V is applied to the Main Motor and at 3-3/4 ips, 85V is applied to the Main Motor.

At Forward Playback, TR110 is turned on, and TR111 is turned off. C101 of T.D. circuit passes R101 and is charged.

## 2. FROM FORWARD TO REVERSE PLAYBACK

When the Reverse Button is depressed or when the sensing tape passes the sensing pole, TR110 is turned off and TR111 is turned on. Consequently, RL105, RL106, and RL1 of Volume P.C. Board is turned on. When RL106 is momentarily turned on, C101 passes R103 and VR101 and discharge begins. C101 discharge current flows to the base of TR101 and TR102 and they are turned on. When this occurs, RL101 is turned on, and Brake Plunger as well as Pinch Roller Plunger is turned off. At this time, the capstan motor begins reverse revolutions. (While RL101 is "ON", because increased torque is applied to the capstan motor, high voltage is applied.)

When discharge of C101 is completed, TR101 and TR102 are turned off. RL101 is also turned off and voltage is supplied to the Pinch Roller Plunger as well as to the Brake Plunger and Playback is effected.

## 3. FROM REVERSE TO FORWARD PLAY

When the FWD Button is depressed or the sensing tape passes the sensing pole, TR111 is turned off and TR110 is turned on. Because TR111 is turned off, RL105 and RL106 as well as RL1 are turned off. When RL106 is momentarily turned off, C102 passes R103 and VR101 and discharge commences. C102 discharge current flows to the base of TR101 and TR102 and they are turned on. When this occurs, RL101 is turned on and the Brake Plunger as well as the Pinch Roller Plunger are turned off. At this time, the capstan motor begins forward revolutions. (While RL101 is "ON", because increased torque is applied to the capstan motor, high voltage is applied.)

When discharge of C102 is completed, TR101 and TR102 is also turned off and voltage is supplied to the Pinch Roller Plunger as well as to the Brake Plunger and Forward Playback is effected. Charge of C101 is begun.

## 4. FAST FORWARD

When the Fast Forward Button is depressed, current flows to RL102 and RL103. At the same time, TR105 and TR106 is maintained at "ON", and Fast Forward operates. 100V is applied to the right side torque motor and about 11V to the left side torque motor. When Fast Forward is effected from Forward Playback, D113 is activated and cuts off TR107.

When Fast Forward is effected from Reverse Playback, D113, D114 is activated and cuts off TR107, TR111.

When Fast Forward is effected from Rewind, TR105 remains "ON", TR106 operates and RL103 is turned on.

## 5. REWIND

When the Rewind Button is depressed, TR105 is turned on. TR105 is maintained at "ON" by means of RL102, 100V is applied to the left side torque motor and about 11V to the right side torque motor.

When Rewind is effected from Forward Playback, D112 is activated and cuts off TR107. When Rewind is effected from Reverse Playback, D108, D112 is activated and cuts off TR107, TR111.

When Rewind is effected from Fast Forward, D104 is activated and cuts off TR106.

# VIII. SERVO MOTOR OPERATING PRINCIPLES

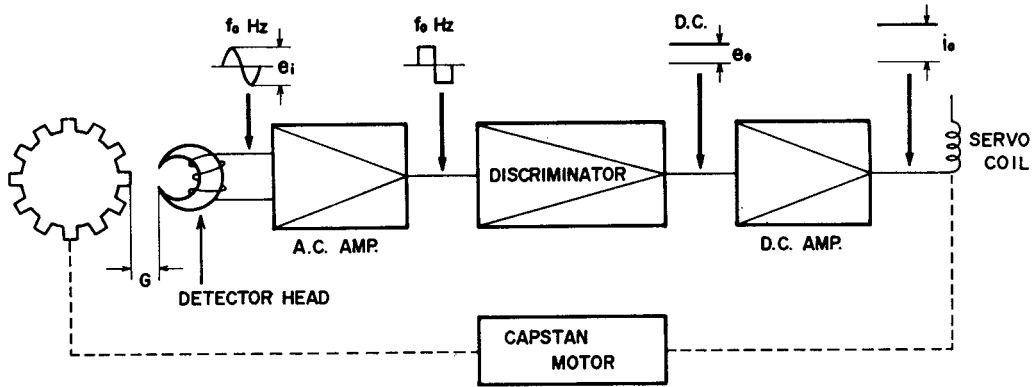

G (Gap): Adjust to obtain a detector head terminal voltage of  $3 \pm 0.5$  mV at 7-1/2 ips.

Fig. 27

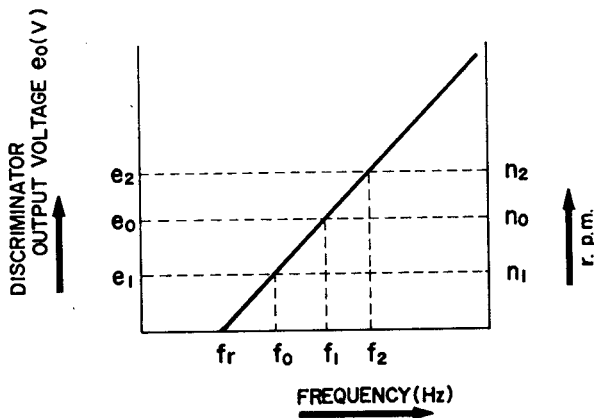

Fig. 28

1. The detector head core is comprised of a permanent magnet, and the gear installed on the rotor, by means of the capstan motor revolutions, changes the magnetic flux of the detector head core. Accordingly, the detector head coil works in the same way as A.C. generator and generates A.C. Voltage (becomes the detector signal described below). When this detector signal voltage ( $e_i$ ) becomes detector signal frequency ( $f_0$ ), this adjusts the capstan motor revolutions proportionately. (See Figs. 27, 28)
2. When the detector signal voltage generated from the detector head is about 3 mV (at 7-1/2 ips), because the level is low, the detector signal is amplified by the A.C. Amplifier until the waveform is clipped. (See Fig. 27)

3. Discriminator Coil L1 (VI2031SC-01) and C210 (0.051/50) at 7-1/2 ips and C211 (0.27/100) at 3-3/4 ips constitute the resonance circuit, and this resonance frequency becomes  $f_r$ . Because the detector signal frequency generated at the detector coil differs according to capstan motor revolutions, the capacity of the discriminator resonance condenser changes and the resonance frequency  $f_r$  changes at the different tape speeds of 7-1/2 and 3-3/4 ips.
4. When the discriminator input frequency and the resonance frequency  $f_r$  are simultaneous, the D.C. signal to be supplied to the next stage D.C. Amplifier is not generated. Consequently, when the capstan motor rotates at normal speed, at this time the detector signal frequency  $f_0$  is higher than the resonance frequency  $f_r$ .
5. As shown in Chart 2, when electric current is not flowing to the capstan motor servo coil, the capstan motor revolutions are far faster than normal revolutions. Consequently, in order to maintain normal revolutions, an electro-magnetic field is generated at the servo coil by means of collector current flowing to TR209 (2SD234), and this serves as an electro-magnetic brake. This electro-magnetic brake and the load torque balances the capstan motor torque and normal revolutions are maintained.

TAPE SPEED	Capstan Motor Supply Voltage	Capstan Motor Supply Voltage at FWD or REV Starting Time	Voltage and Frequency Generated at the Detector Coil	Controlled Capstan Motor Speed	Uncontrolled Capstan Motor Speed
7-1/2 ips	110V	150V	$3\text{mV} \pm 0.5\text{mV}$ / $1040\text{Hz}$ r.m.s.	520 r.p.m.	1420 r.p.m.
3-3/4 ips	85V	110V	$1.5\text{mV} \pm 0.25\text{mV}$ / $520\text{Hz}$ r.m.s.	260 r.p.m.	1380 r.p.m.

Chart 2

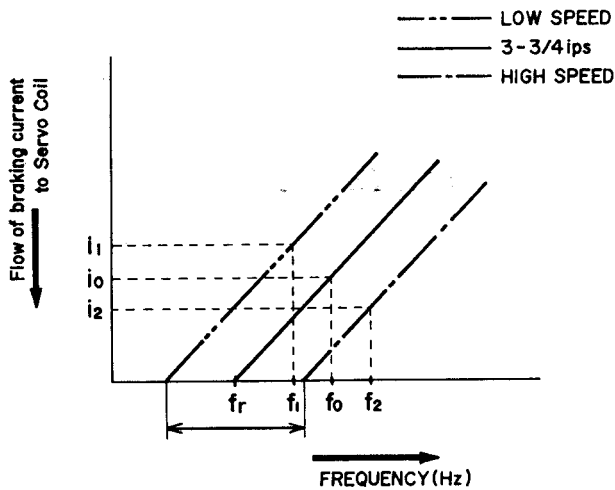

Fig. 29

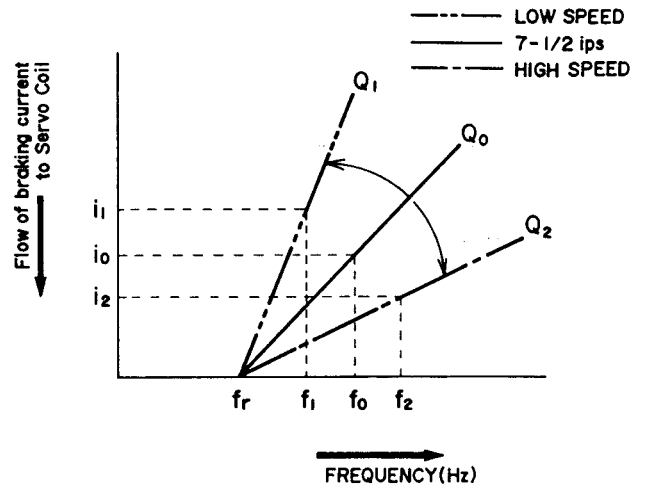
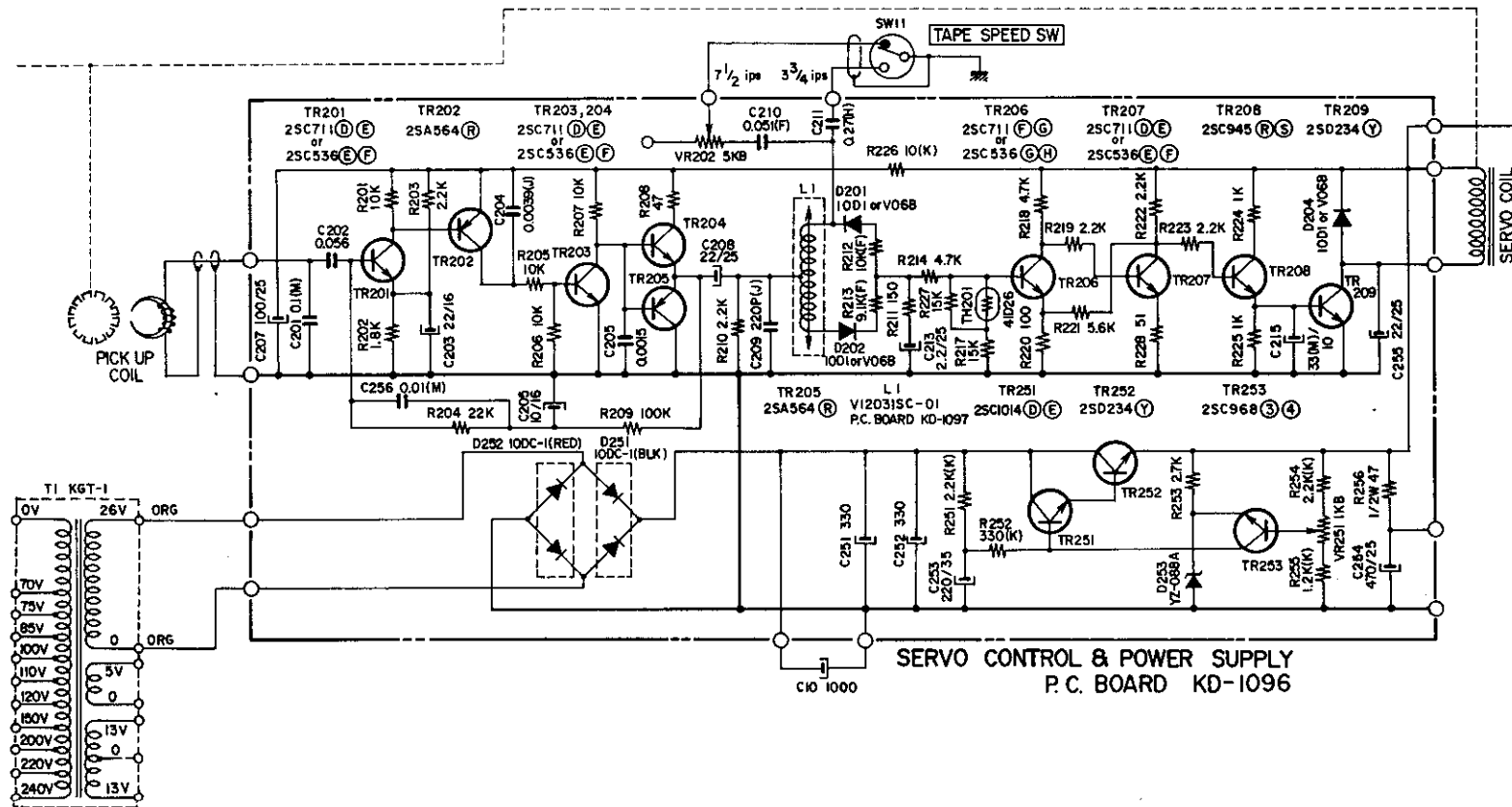
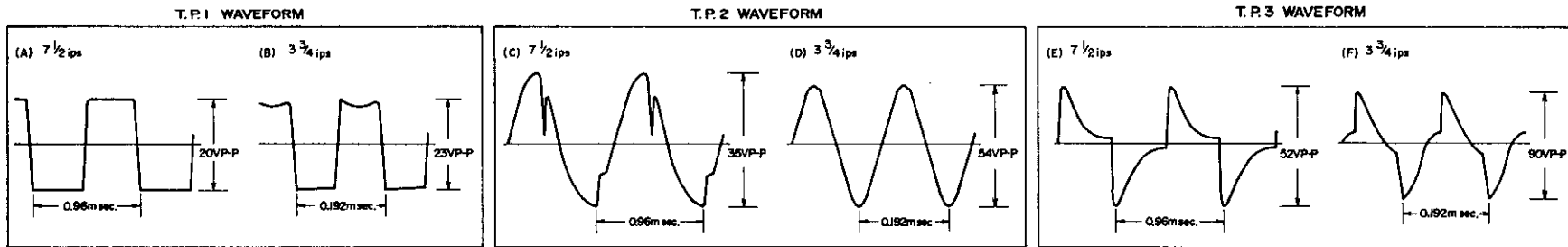

Fig. 30

6. In case of the capstan motor revolutions having reached the speed of  $n_2$ , the detector signal produced at the detector coil surpasses  $f_0$  and advances toward the higher  $f_2$  frequency. (See Figs. 29, 30) Accordingly, the flow of current to the servo coil increases, and because the electro-magnetic braking supplied to the capstan motor is increased, the capstan motor revolutions become slower, and normal revolutions are regained.
7. In case of the capstan motor revolutions having slowed to  $n_1$ , the detector signal produced at the detector coil drops to lower than  $f_0$  and descends toward the low  $f_1$  frequency. (See Figs. 29, 30) Accordingly, the flow of current to the servo coil decreases, and because the electro-magnetic braking supplied to the capstan motor is decreased, the capstan motor revolutions speed up and normal revolutions are regained.
8. To obtain the proper number of revolutions, adjustment of the flow of brake current to the servo coil is necessary.
  - 1) At 3-3/4 ips tape speed  
As shown in Fig. 29, resonance frequency  $f_r$  (between the arrow mark) is changed by adjusting the dust core of discriminator coil L1 (VI2031SC-01). Accordingly,  $f_0$  is also changed between  $f_1$  and  $f_2$ , and the flow of braking current ( $i_0$ ) to the servo coil is also changed between  $i_1$  and  $i_2$ . Consequently, correct tape speed can be attained by using a tape speed measuring tape and a Frequency Counter and adjusting the dust core of coil L1.
  - 2) At 7-1/2 ips tape speed  
As shown in Fig. 30,  $Q_0$  of the resonance circuit (within the arrow mark with  $f_r$  as center frequency), is changed by adjusting discriminator semi-fixed resistor VR202 (5 k $\Omega$ ). Therefore,  $f_0$  is also changed between  $f_1$  and  $f_2$  and, the flow of current ( $i_0$ ) to the servo coil is also changed between  $i_1$  and  $i_2$ . Consequently, correct tape speed can be attained by using a tape speed measuring tape and a Frequency Counter and adjusting semi-fixed resistor VR202.





SERVO CONTROL AMP. & POWER SUPPLY SCHEMATIC DIAGRAM

SCHEMATIC-2

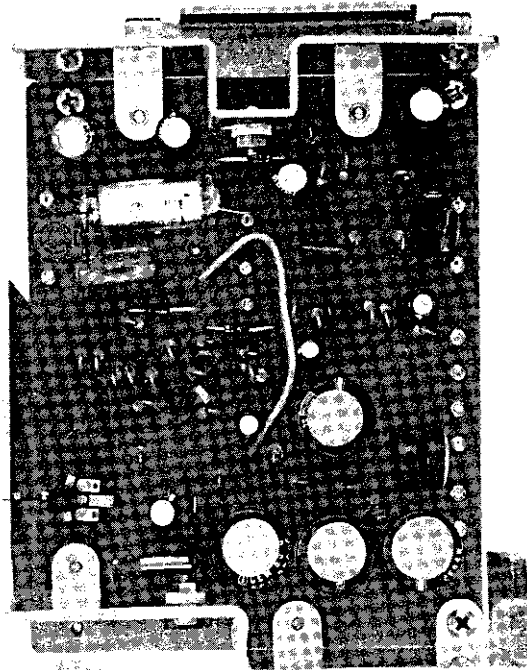

Fig. 31 SERVO CONTROL AMP. & POWER SUPPLY P.C. BOARD KD-1096 (Face Side)

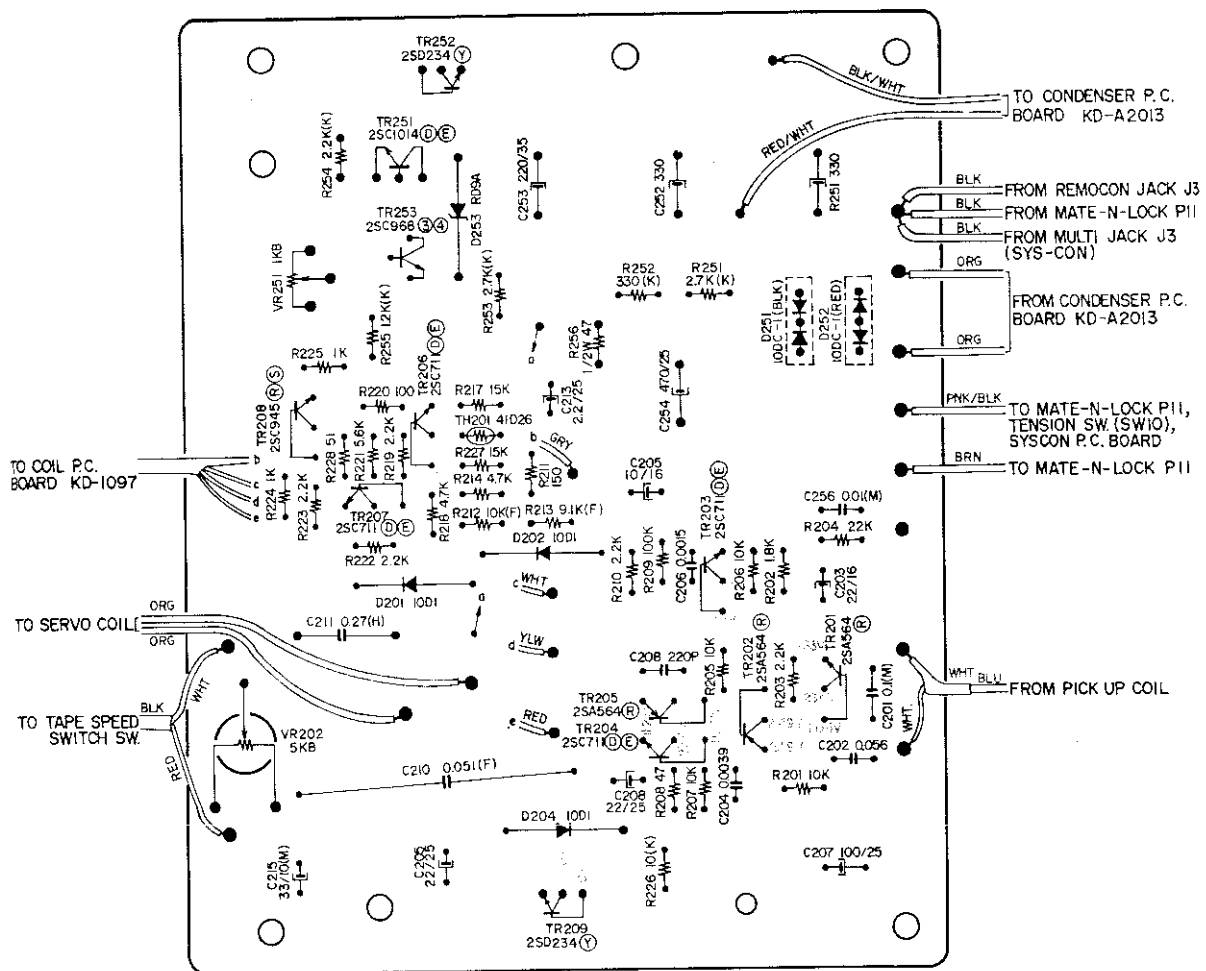

Fig. 32 SERVO CONTROL AMP. & POWER SUPPLY P.C. BOARD KD-1096 (Reverse Side)

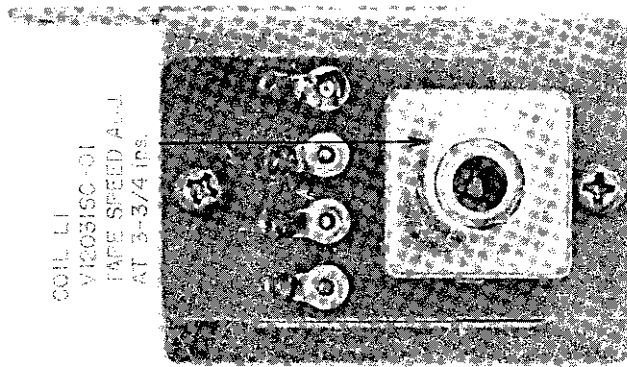

Fig. 33 COIL P.C. BOARD KD-1097 (Face Side)

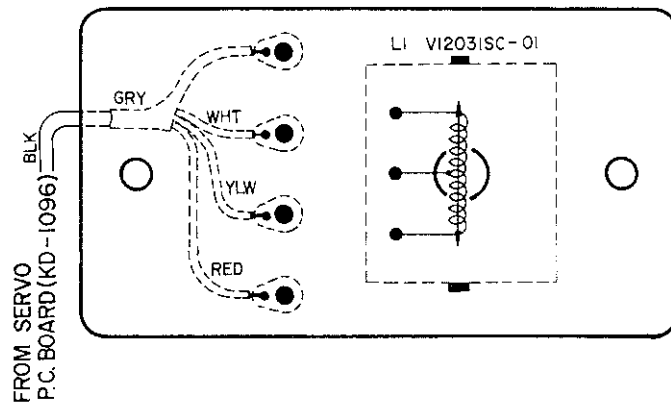

Fig. 34 COIL P.C. BOARD KD-1097 (Reverse Side)

# IX. MOTOR AND COIL D.C. RESISTANCE

NOTE: The various D.C. resistance stated below will vary slightly depending upon the measuring instruments.

## 1. SERVO MOTOR (TYPE: SCM2-24) AND PICK UP COIL

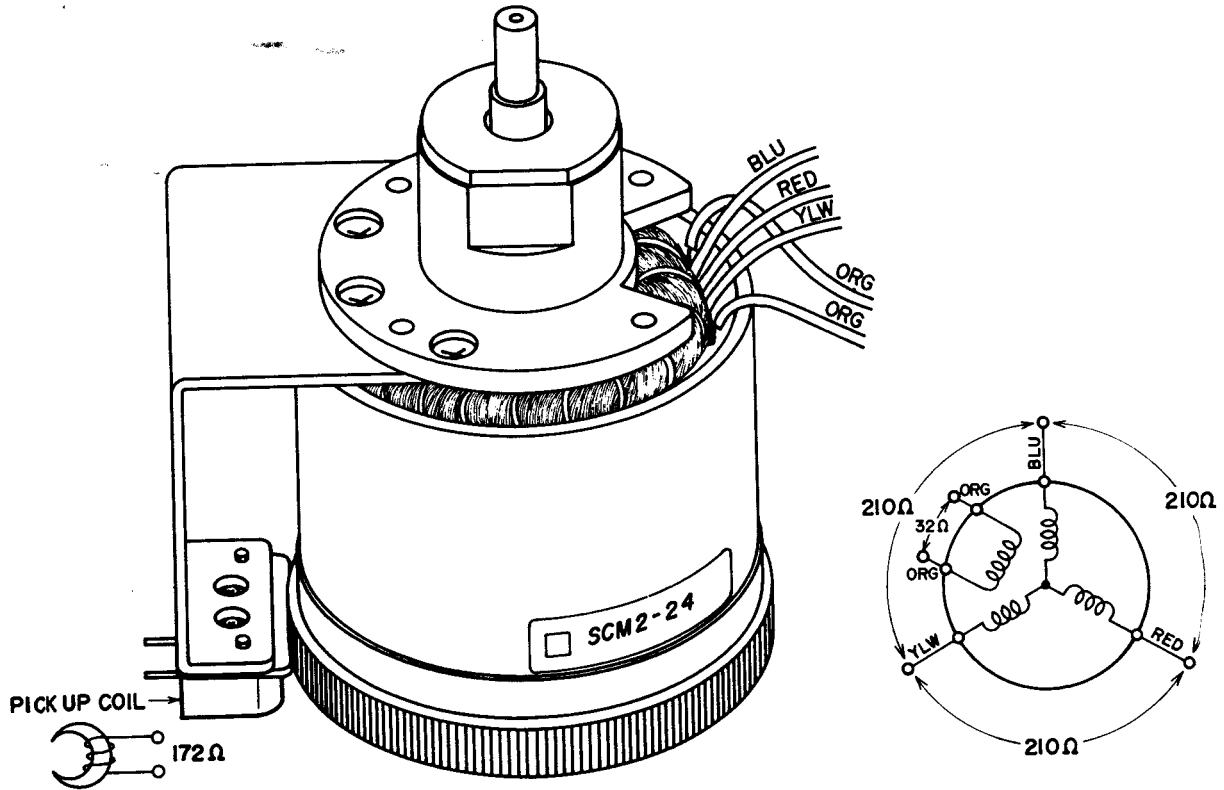
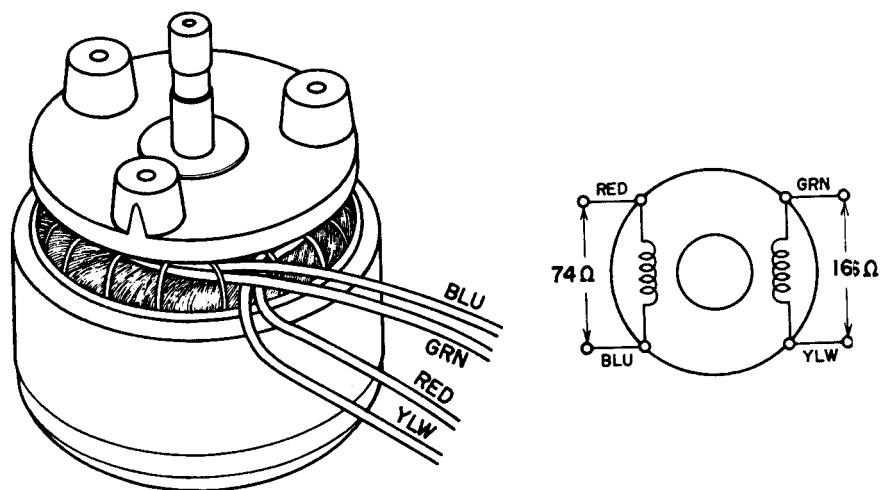

Fig. 35

## 2. TORQUE MOTOR (TYPE: 24XO-MR)



### 3. OTHER PARTS

I.D.	Type	D.C. Resistance	Remarks
ERASE HEAD	E4-250	2Ω	one channel
RECORDING HEAD	R4-200	7.4Ω	one channel
PLAYBACK HEAD	P4-200	488Ω	one channel
BRAKE PLUNGER SOLENOID	SDC-10CM-100V	1,276Ω	
PINCH WHEEL PLUNGER SOLENOID	1660THTI-100V	1,064Ω	
REVERSE PLUNGER SOLENOID	M-10B-34V	145Ω	
RELAY	MY4-O-US-AD4 DC 24V	678Ω	
RELAY	TECK-36	1,010Ω	
HEAD PHONE OUTPUT TRANS	228S	590Ω	Primary Side
		1.4Ω	Secondary Side
DISCRIMINATOR COIL	V1023SC-01	648Ω	Between 1-3
		324Ω	Between 1-2, 2-3
OSCILLATOR COIL	OT-204	0.3Ω	Between 1-3
		0.7Ω	Between 4-6
		8.4Ω	Between 7-9

Chart 3

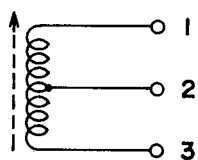

DISCRIMINATOR COIL

Fig. 37

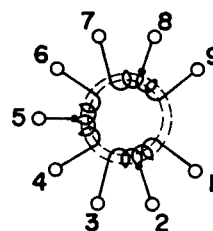

OSCILLATOR COIL

Fig. 38

# X. COMPOSITE VIEWS OF COMPONENTS

## 1. TONE CONTROL AMP. P.C. BOARD MS-5028

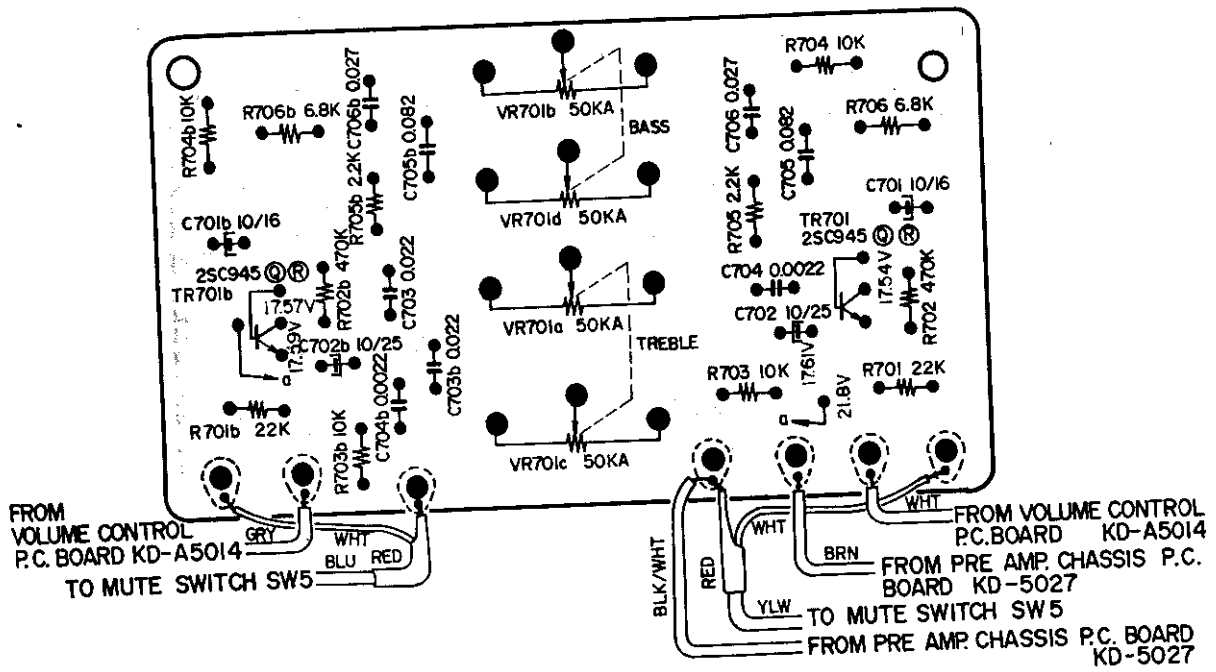

## 2. POWER AMP. P.C. BOARD KD-A5015

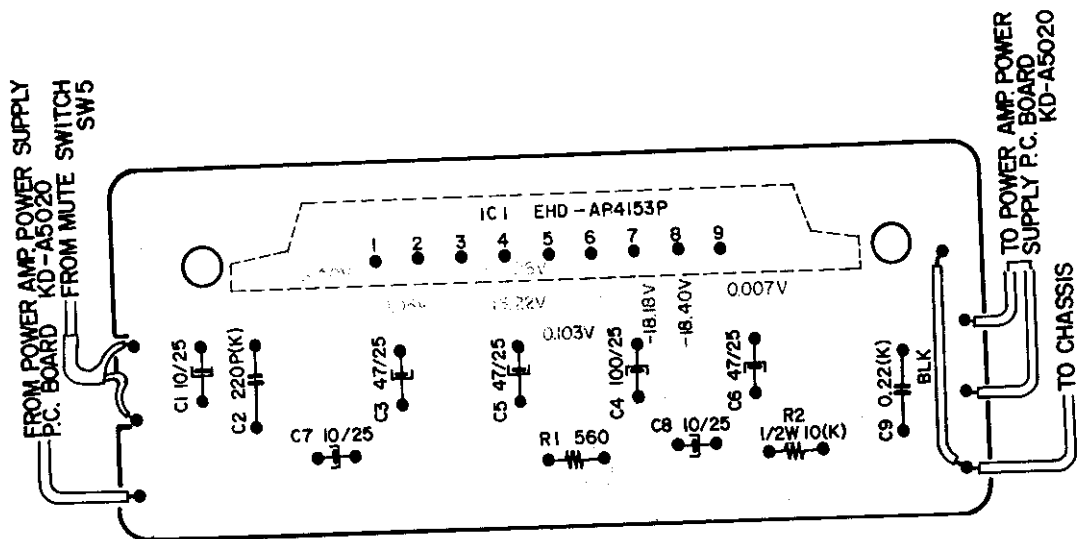



## 6. SWITCH P.C. BOARD KD-A1009

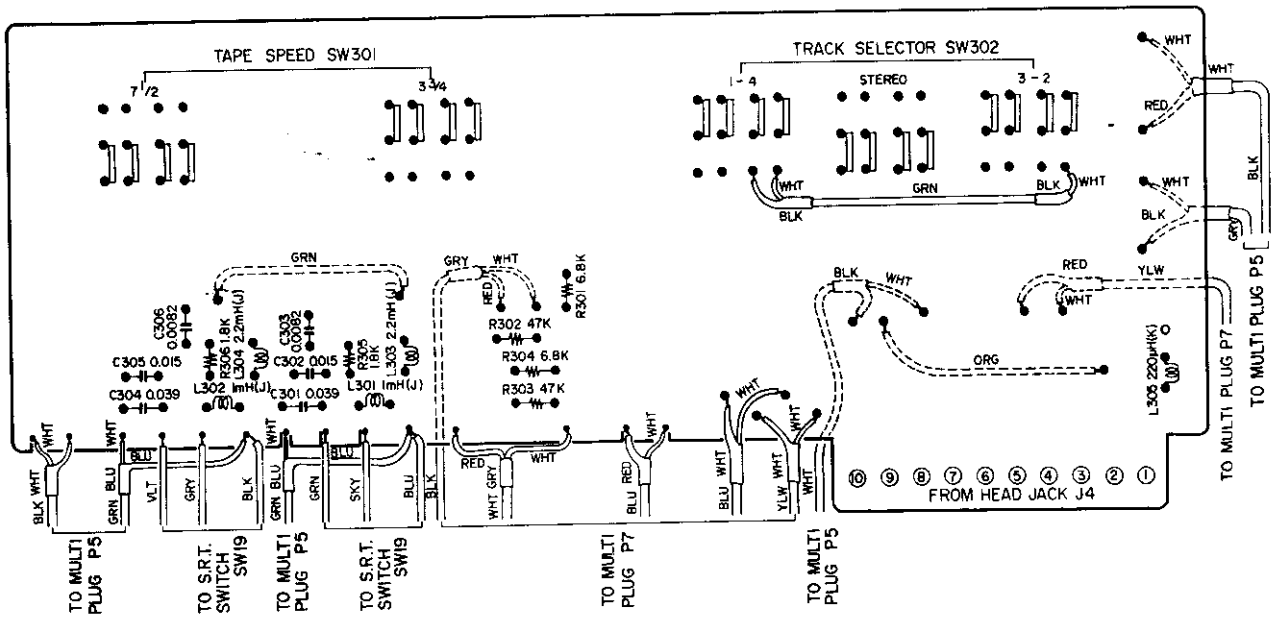

## 7. CONDENSER P.C. BOARD KD-A2013

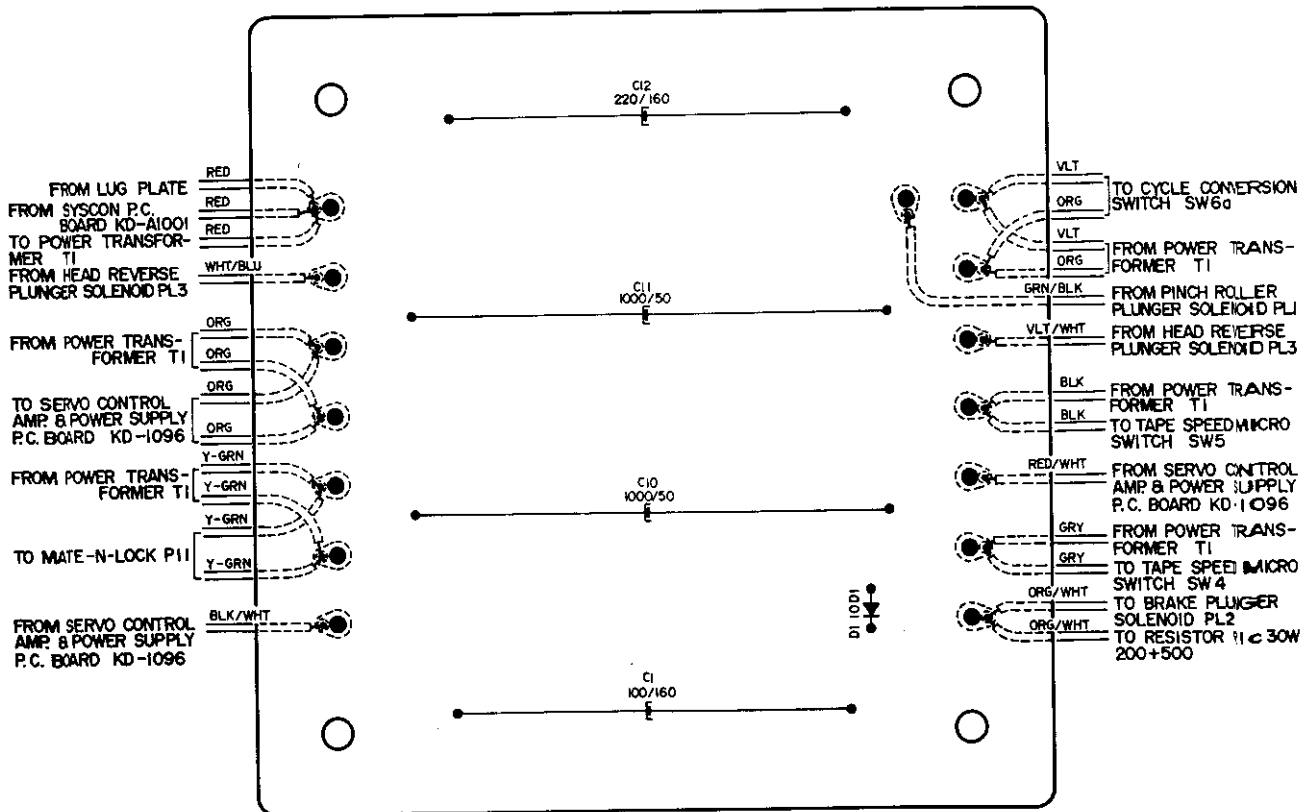



# 8. PRE AMP. CHASSIS P.C. BOARD KD-5027

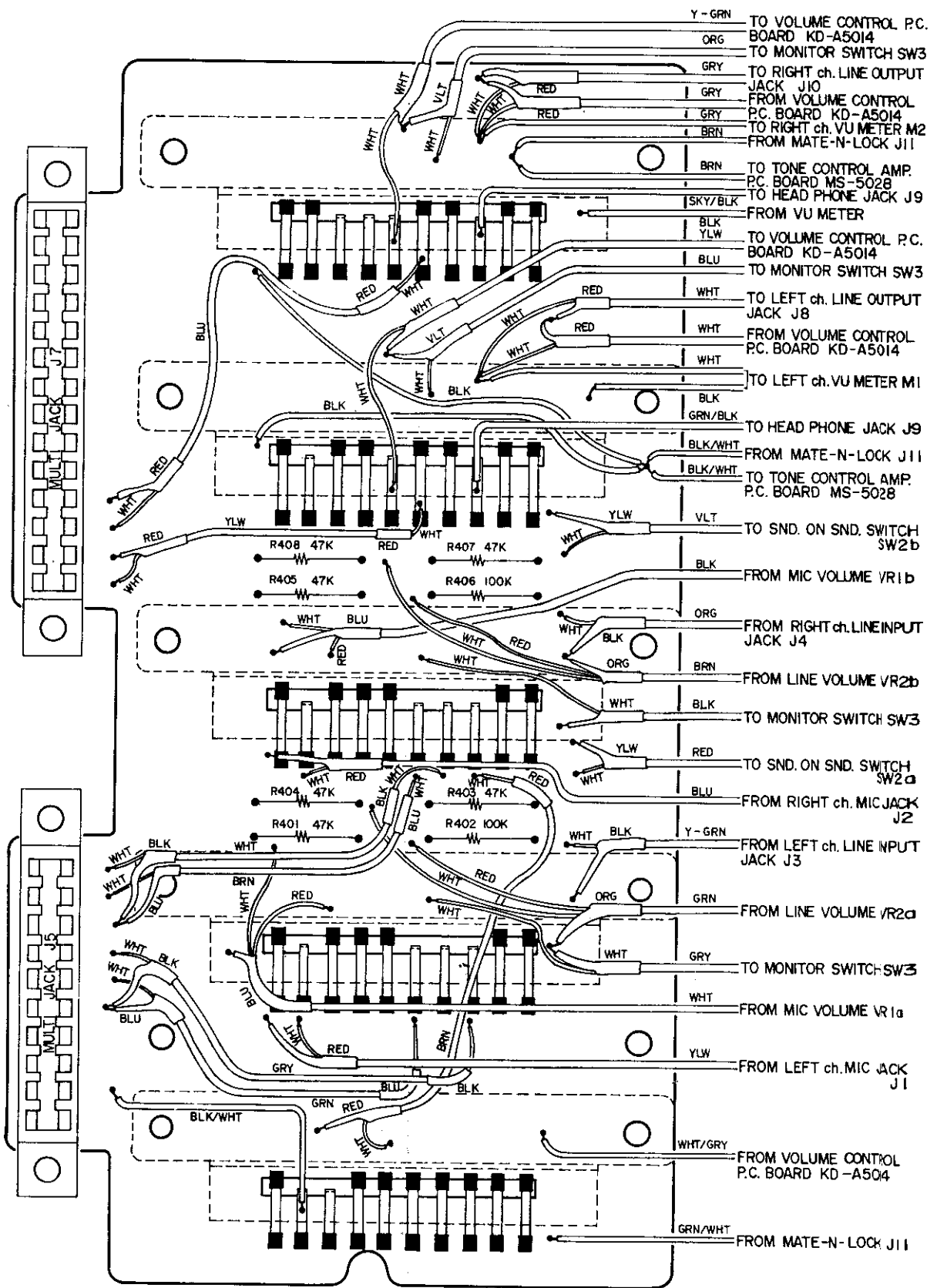

---

SECTION 2  
**PARTS LIST**

TABLE OF CONTENTS

FIG. 1	KG HEAD BLOCK .....	38
FIG. 2	REEL MOTOR/REEL TABLE BLOCK .....	40
FIG. 3	MAIN MOTOR BLOCK .....	42
FIG. 4	OPERATION BLOCK .....	43
FIG. 5	MECHANISM ASSEMBLY BLOCK (1) .....	44
FIG. 6	MECHANISM ASSEMBLY BLOCK (2) .....	46
FIG. 7	REC. AMP. P.C. BOARD (KD-A5011) BLOCK .....	47
FIG. 8	P.B. AMP. P.C. BOARD (KD-A5010) BLOCK .....	48
FIG. 9	SERVO P.C. BOARD (KD-1096) BLOCK .....	49
FIG. 10	SYS. CON. P.C. BOARD (KD-A1001A) BLOCK .....	50
FIG. 11	OSC. P.C. BOARD (KD-A5004) BLOCK .....	51
FIG. 12	MAIN AMP. P.C. BOARD (KD-A5015) BLOCK .....	52
FIG. 13	SWITCH P.C. BOARD (KD-A1009) BLOCK .....	52
FIG. 14	PRE AMP. CHASSIS P.C. BOARD (KD-5027) BLOCK ..	53
FIG. 15	TONE CONTROL P.C. BOARD (MS-5028) BLOCK ..	53
FIG. 16	VOLUME P.C. BOARD (KD-A5014) BLOCK .....	54
FIG. 17	COIL P.C. BOARD (KD-1097) BLOCK .....	54
FIG. 18	POWER SUPPLY P.C. BOARD (KD-A5020) BLOCK ..	54
FIG. 19	POWER SUPPLY BLOCK .....	55
FIG. 20	SUB PANEL (LEFT) BLOCK .....	57
FIG. 21	AMP. ASSEMBLY BLOCK .....	58
FIG. 22	FINAL ASSEMBLY BLOCK .....	60
INDEX	.....	61

## HOW TO USE THIS PARTS LIST

1. This parts list is compiled by various individual blocks based on assembly process.
2. When ordering parts, please describe parts number, serial number, and model number in detail.
3. How to read list.

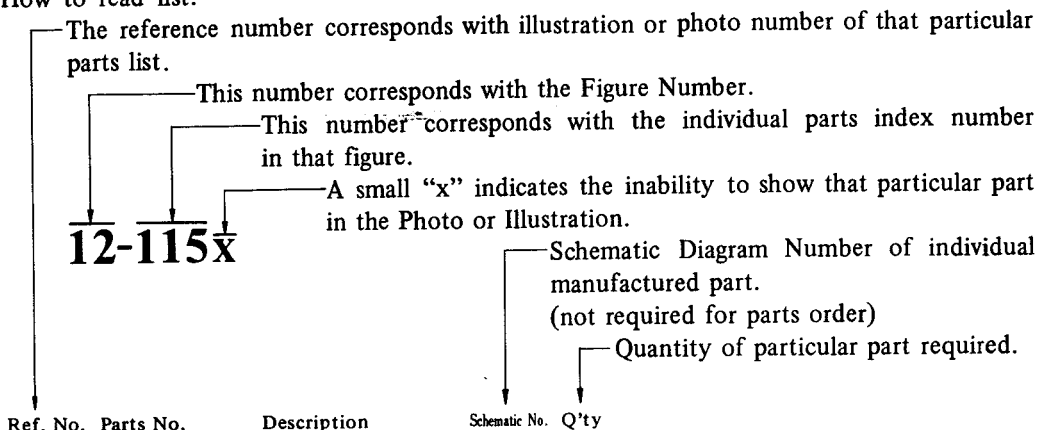

Ref. No.	Parts No.	Description	Schematic No.	Q'ty
<b>FLYWHEEL BLOCK #13</b>				
12-115x	800425	Flywheel Block Assy. Comp.	RDG #13	1
12-116	244506	Flywheel Only	RD-233	1
12-117x	244754	Felt, Flywheel	RD-275	1
12-118	251324	Main Metal Case	RD-236	1
12-119	253080	Main Metal	RD-237	1

4. The symbol numbers shown on the P.C. Board list can be matched with the Composite Views of components of the Schematic Diagram or Service Manual.
5. The indications of Resistors and Capacitors in the photos of P.C. Board are being eliminated.
6. The shape of the parts and parts name, etc. can be confirmed by comparing them with the parts shown on the Electrical Parts Table of P.C. Board.
7. Both the kind of part and installation position can be determined by the Parts Number. To determine where a parts number is listed, utilize Parts Index at end of Parts List.  
It is necessary first of all to find the Parts Number. This can be accomplished by using the Reference Number listed at right of parts number in the Parts Index. (meaning of ref. no. outlined in Item 3 above).
8. Utilize separate "Price List for Parts" to determine unit price. The most simple method of finding parts Price is to utilize the reference number.

## ELECTRICAL PARTS TABLE



<p>Because the indication of resistors and capacitors in the P. C. Board photos are being eliminated, please confirm parts name and shape by comparing them with the parts shown in this table.</p>	<p style="text-align: center;">1</p>  <p style="text-align: center;">Solid Resistor</p>	<p style="text-align: center;">2</p> <p style="text-align: right;">Stopper Type</p>  <p style="text-align: center;">Insulator Type Carbon Resistor</p>	<p style="text-align: center;">3</p>  <p style="text-align: center;">Metal Oxide Film Resistor</p>
<p style="text-align: center;">4</p>  <p style="text-align: center;">Cement Resistor</p>	<p style="text-align: center;">5</p>  <p style="text-align: center;">Wire-Wound Resistor</p>	<p style="text-align: center;">6</p>  <p style="text-align: center;">Thermister</p>	<p style="text-align: center;">7</p>  <p style="text-align: center;">Enamel Resistor</p>
<p style="text-align: center;">1</p>  <p style="text-align: center;">MP Capacitor (Tubular Type)</p>	<p style="text-align: center;">2</p>  <p style="text-align: center;">Plastic Capacitor</p>	<p style="text-align: center;">3</p>  <p style="text-align: center;">Mylar Capacitor</p>	<p style="text-align: center;">4</p>  <p style="text-align: center;">VFM (Hi-Q) Capacitor</p>
<p style="text-align: center;">5</p>  <p style="text-align: center;">Mylar Capacitor</p>	<p style="text-align: center;">6</p>  <p style="text-align: center;">Tantalum Capacitor</p>	<p style="text-align: center;">7</p>  <p style="text-align: center;">Oil Capacitor (Tubular Type)</p>	<p style="text-align: center;">8</p> <p style="text-align: right;">Vertical Type</p> <p>(Tubular Type)</p>  <p style="text-align: center;">Styrol Capacitor</p>
<p style="text-align: center;">9</p>  <p style="text-align: center;">Electrolytic Capacitor (Tubular Type)</p>	<p style="text-align: center;">10</p> <p style="text-align: right;">Vertical Type</p> <p>(Tubular Type)</p>  <p style="text-align: center;">Electrolytic Capacitor</p>	<p style="text-align: center;">11</p>  <p style="text-align: center;">Ceramic Capacitor</p>	<p style="text-align: center;">12</p>  <p style="text-align: center;">Metalized Mylar (Paper) Capacitor</p>
<p style="text-align: center;">13</p>  <p style="text-align: center;">Trimmer Condenser</p>		<p style="text-align: center;">VR</p>  <p style="text-align: center;">Semi-Fixed Volume</p>	
<p style="text-align: center;">L</p>  <p style="text-align: center;">Ferri Inductor</p>	<p style="text-align: center;">TR</p>  <p style="text-align: center;">Transistor</p>		
<p style="text-align: center;">CR</p>  <p style="text-align: center;">Spark Quencher</p>	<p style="text-align: center;">D</p>  <p style="text-align: center;">Diode (Silicon, Zener, Germanium)</p>		

FIG. 1 ILLUSTRATION OF KG HEAD BLOCK



## KG HEAD BLOCK

Ref. No.	Parts No.	Description	Schematic No.	Q'ty	Ref. No.	Parts No.	Description	Schematic No.	Q'ty
1-1x	BH426240	KG Head Block Comp.		1	1-70	ZW426587	Washer (SPC)D3.1x8x0.5t		1
1-2	HZ426486	Head Chassis, w/shaft A	KD-A0001	1	1-71	ZW413223	Screw, binding head 3x5,		
1-3	HZ396494	Mech. Panel Prop	KD-0006	2			w/washer		1
1-4x	ZW403301	Screw, binding head 3x6,			1-72x	EJ364915	10P Multi-jack PB01-10S-24E2G	31-4-15	1
		w/washer		1	1-73x	MZ373318	Nylon Clip HP-3N		1
1-5x	ZW200305	Screw, countersunk head 3x5		1	1-74x	ZW399295	Screw, binding head 3x6		1
1-6	HZ412637	Tape Guide Post	RD-A30	1	1-75	HZ231884	Tape Guide B	RD-5	1
1-7x	ZW273802	Toothed Lock Washer M3		2	1-76	ZW383840	Set Screw 3x5 (cup)		1
1-8	ZW273756	Nut M3		4	1-77	HZ321434	Dust-proof Cap B	RD-54	1
					1-78	ZW260201	Washer (Nylon)D6.2x13x1t		2
1-9x	BZ435003	Sensing Guide (B) Block Comp.	KD, KF	1	1-79	HZ433890	Shifter Stopper B	KD-A0011	1
1-10	HZ396584	Sensing Guide C	KD-0015	1	1-80	HL426510	Shifter Lever (1), w/pin	KD-A0005	1
1-11	HZ396797	Sensing Guide	KD-0036	1	1-81	HZ426543	Shifter Joint (1)	KD-A 0008	1
1-12	ZW439402	Screw, round head 3x3.2		1	1-82	ZW270101	'E' Ring 3M	6-1-9	3
1-13	HZ317632	Insulator Collar A	MR-36	1	1-83	HL426521	Shifter Lever (2), w/pin	KD-A0006	1
1-14	HZ396595	Sensing Guide D	KD-0016	1	1-84	HZ426554	Shifter Joint (2)	KD-A0009	1
1-15	ZW273778	Earth Lug M3		1	1-85	HL426565	Shifter Lever (3), w/pin	KD-A0007	1
1-16	HZ396505	Insulator Collar	KD-0007	1	1-86	ZW290283	'U' Ring 2.85M	6-1-1	3
1-17	ZW396786	Tape Guide Washer	KD-0035	1					
1-18	ZW202252	Screw, round head 2.3x12		1					
1-19x	ZW434250	Screw, pan head 4x8, w/washer		2					
1-20	HZ803597	Tape Guide A	RD-3	1					
1-21	HZ434272	Shifter Stopper Collar	KD-A0010	1					
1-22	MZ428343	KD Stopper Rubber	KD-1088	1					
1-23x	ZW417148	Screw, binding head 3x15		1					
1-24	HZ426666	PH Adjust Base, w/metal	KD-A0004	1					
1-25	ZG206144	Angle Adjust Spring	RD-16	3					
1-26	ZW426611	Screw, binding head 3x12		2					
1-27	ZW426655	Screw, binding head 3x20		1					
1-28	HZ382680	Erase Head Base	RD-A5	1					
1-29	HE412187	ERASE HEAD E4-250		1					
1-30x	ZW201464	Screw, pan head 2x3		2					
1-31	ZW323728	Screw, binding head 3x5		2					
1-32x	ZW273778	Earth Lug M3		2					
1-33	HZ382691	RH Head Angle	RD-A6	1					
1-34	HR384513	REC. HEAD R4-200		1					
1-35	ZW383646	Screw, pan head 2x4		4					
1-36	ZG382757	Angle Adjust Spring D	RD-A12	3					
1-37	ZW336868	Screw, round head 3x12		3					
1-38	ZW200226	Screw, countersunk head 3x12		1					
1-39x	EA463206	P.C. Board A, Terminal	RD-A36	3					
1-40x	EA466547	P.C. Board B, Terminal	KD-A0013	1					
1-41	HZ382656	PH Head Angle	RD-A2	1					
1-42	HP384524	P.B. HEAD P4-200		1					
1-43	HZ382667	Triple-shield	RD-A3	1					
1-44	ZW426622	Washer (SPC)D3.4x7.8x0.5t		2					
1-45	ZW403312	Hexagon Bolt 3x4		2					
1-46	HZ426497	PH Head Base	KD-A0002	1					
1-47	HZ426508	PH Hold-down Guide	KD-A0003	1					
1-48	ZW200362	Screw, countersunk head 3x5		3					
1-49	ZW345982	Screw, binding head 3x5,							
		w/washer		5					
1-50	MS809987	PH Hold-down Base Shaft	RD-15	1					
1-51	ZG321445	RD Reverse Spring	RD-18	1					
1-52	ZW259648	Washer (PBS)D3x5x0.1t		1					
1-53	ZW273868	Cap Nut M3		1					
1-54	ZG303300	Angle Adjust Spring B	RD-55	2					
1-55	ZW345914	Screw, round head 3x10		1					
1-56	HZ810011	PH Base Stopper B	RD-19	1					
1-57	ZW810055	PH Hold-down Pull Spring	RD-52	1					
1-58	EP804813	Plunger Solenoid M-10B-34V	44-1-16	1					
1-59	HZ317698	Plunger Base	RD-21	1					
1-60	HZ321344	Plunger Retaining Prop	RD-7	2					
1-61	ZW323728	Screw, binding head 3x5		1					
1-62	HZ321366	Retaining Plate	3A-72	1					
1-63	HZ321377	Plunger Joint A	RD-22	1					
1-64	ZW328577	Screw, binding head 3x8,							
		w/washer		2					
1-65	HZ320940	PH Hold-down Lever Support	RD-23	1					
1-66	HL809998	PH Hold-down Lever	RD-24	1					
1-67	ZW257477	Connecting Pin	RD-211	1					
1-68	ZW270088	'E' Ring 1.9M	6-1-9	3					
1-69	ZG246857	Pull Lever Spring	RD-25	1					

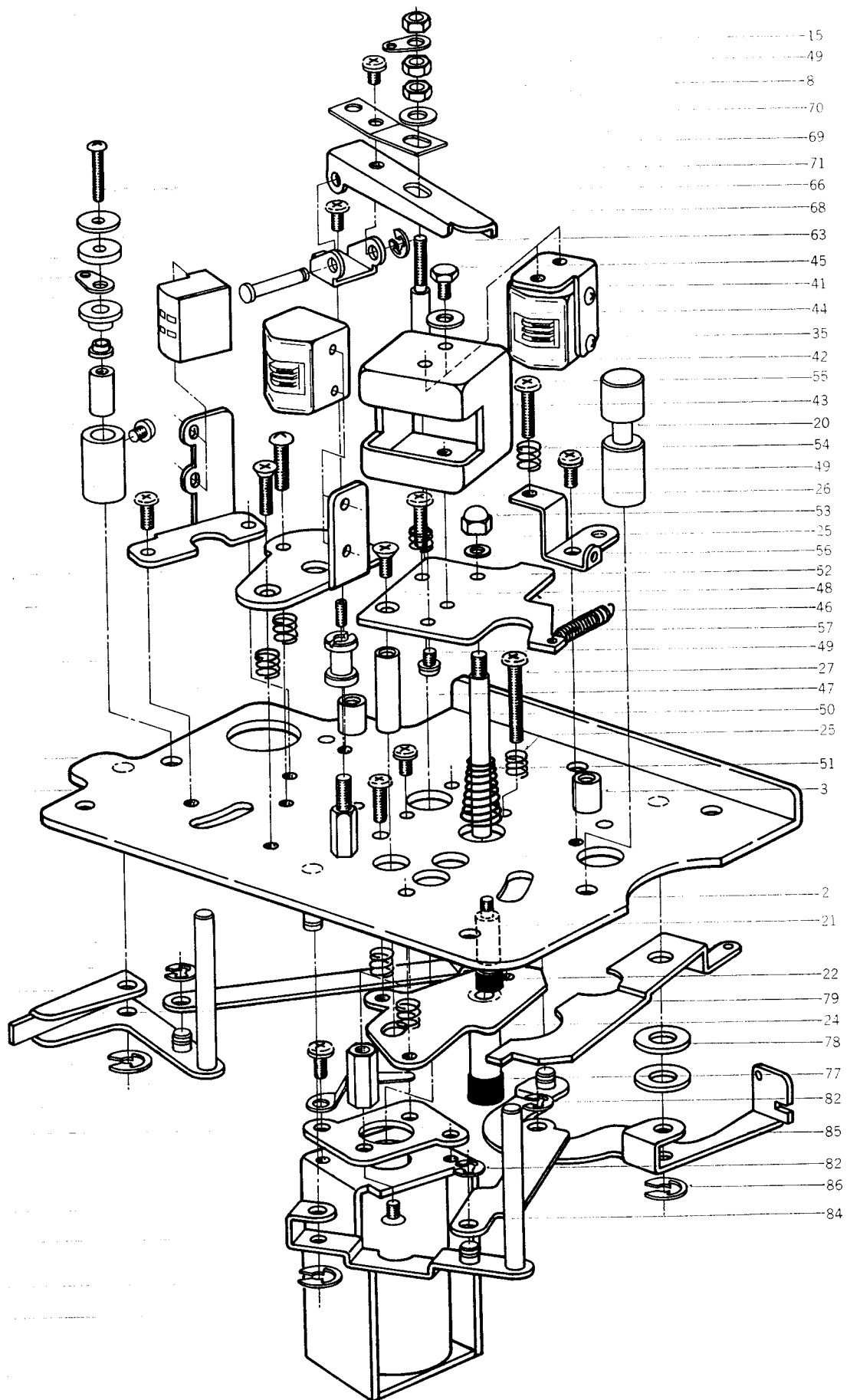
When ordering parts, please describe Parts Number, Serial Number, and Model Number in detail.

FIG. 2 ILLUSTRATION OF REEL MOTOR/REEL TABLE BLOCK

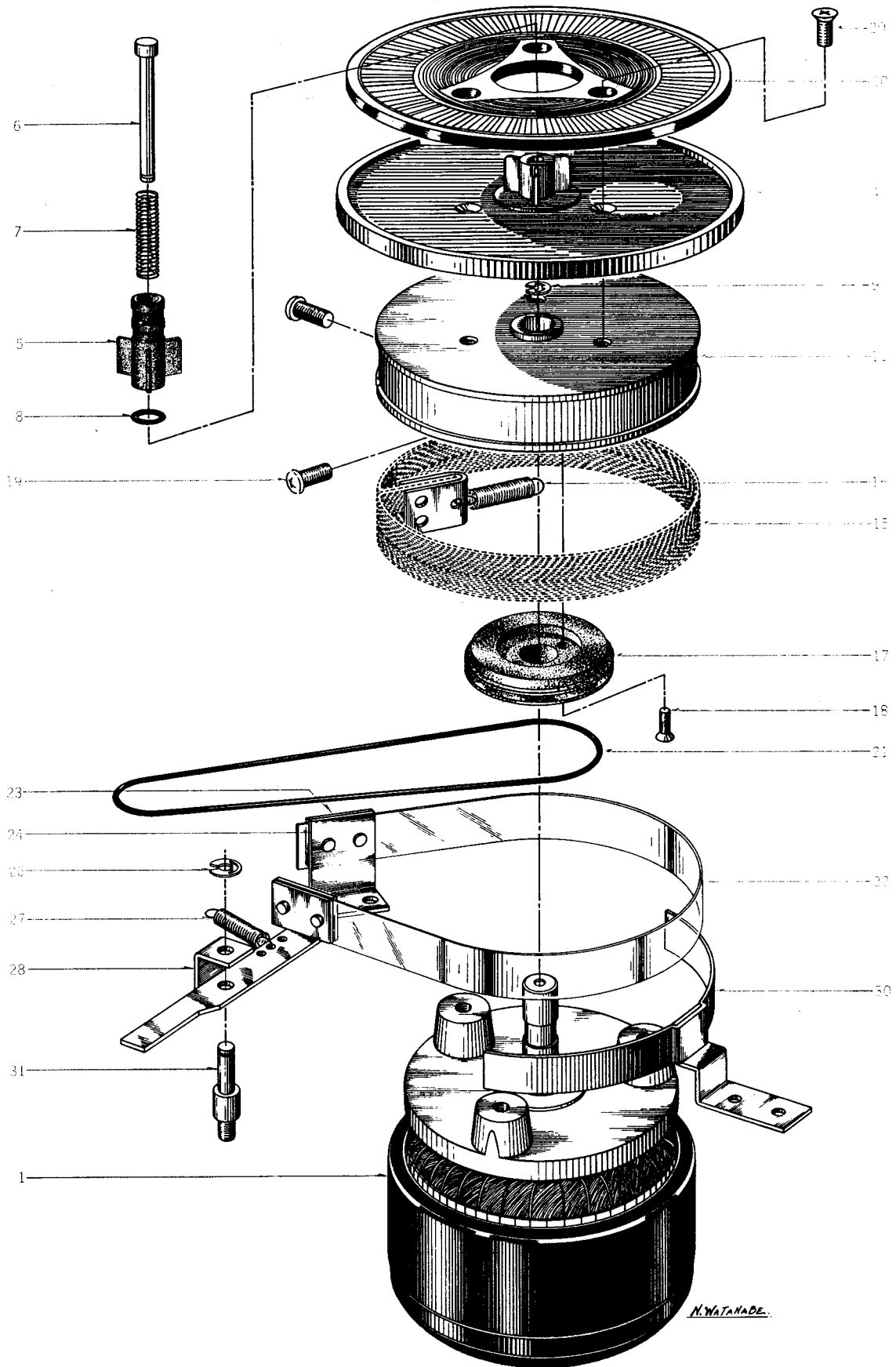

## REEL MOTOR/REEL TABLE BLOCK

Ref. No.	Parts No.	Description	Schematic No.	Q'ty
2-1	BM314741	Reel Motor Block (24X0-2)		
		Comp.	KD, MR, MS, KF	1
2-2x	BR398430	Reel Table Block Comp.		
		(Supply)	KD, KF	1
2-3x	BR398441	Reel Table Block Comp.		
		(Take-up)	KD, KF	1
2-4	MT488158	RDReel Table Disk A	RD-272	1
2-5	MT255420	Reel Retainer	3R-102	1
2-6	MS342000	Reel Shaft	3R-108	1
2-7	ZG255633	Reel Spring	3R-109	1
2-8	MT297663	3R 'O' Ring 2.9x1.65M	3R-139	1
2-9	ZW270088	'E' Ring 1.9M	6-1-9	1
2-10	MT397225	Reel Table Rubber	KD-2017	1
2-11	MT495606	Brake Drum (R) A (Take-up)	MR-216	1
2-12x	MT495617	Brake Drum (L) A (Supply)	MR-216	1
2-13x	ZW273778	Earth Lug M3		2
2-14x	ZW425981	Screw, binding head 3x3		2
2-15	MT436860	Brake Cloth Comp.	MR-269	1
2-16	ZG317496	Felt Tension Spring	MR-260	1
2-17	MR317507	Counter Pulley (Take-up)	MR-217	1
2-18	ZW516644	Screw, countersunk head 2.3x10 (Take-up)		2
2-19	ZW424056	Screw, pan head 4x10		2
2-20	ZW403222	Screw, countersunk head 3x10		3

## MECHANISM ASSEMBLY BLOCK

2-21	MB303535	Counter Belt D91x1.6	3A-617	1
2-22	MB314987	Brake Band	MR-213	1
2-23	MZ314998	Brake Band Retaining Plate	MR-212	2
2-24	MZ315000	Brake Band Support	MR-214	1
2-25x	ZW323728	Screw, binding head 3x5		6
2-26	ZW290283	'U' Ring 2.85M	6-1-1	1
2-27	ZG315011	Brake Lever Spring	MR-116	1
2-28	ML314976	Brake Lever A (Take-up)	MR-210	1
2-29x	ML396810	Brake Lever B (Supply)	KD-1038	1
2-30	MZ317406	Brake Band Guide, w/base	MR-120	1
2-31	MZ317373	Brake Lever Prop	MR-102	1

When ordering parts, please describe Parts Number, Serial Number, and Model Number in detail.



FIG. 3 ILLUSTRATION OF MAIN MOTOR BLOCK

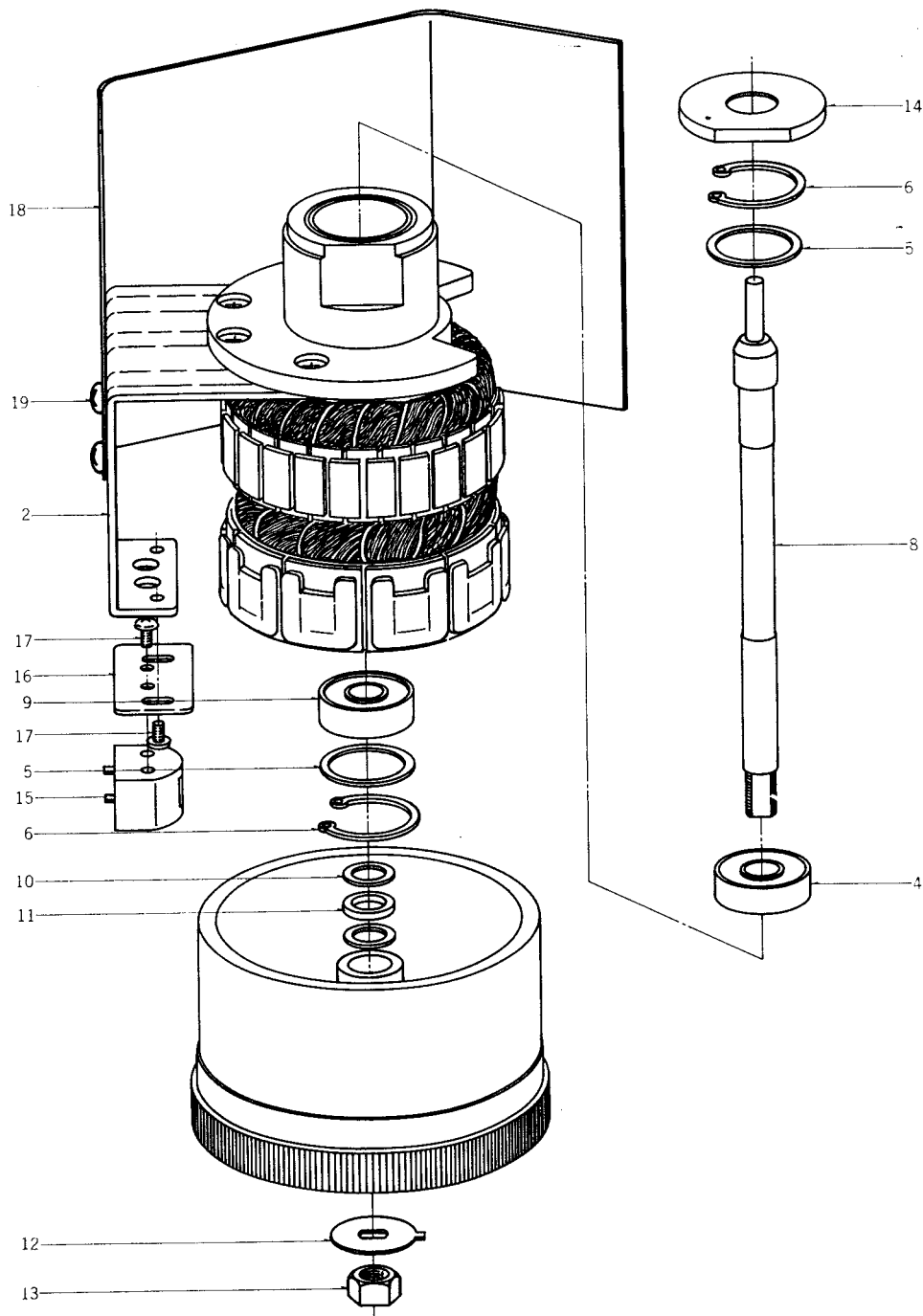

**MAIN MOTOR BLOCK**

Ref. No.	Parts No.	Description	Schematic No.	Q'ty	Ref. No.	Parts No.	Description	Schematic No.	Q'ty
3-1x	BM423854	Main Motor Block (SCM-24)			3-12	ZW398158	Servo Motor Anti Loosening Washer	KD-7022	1
		Comp.	KD, KF	1					
3-2	MZ405437	Detector Head Mt. Base	KD-7029	1	3-13	ZW403536	Nut M7 P=0.5		1
3-3x	ZW419747	Screw, countersunk head 4x6		4	3-14	MZ398182	Cap	KD-7026	1
3-4	MV408510	Bearing 608VVC2E-AV2-L		1					
3-5	ZW398125	Adjust Washer A	KD-7019	2	3-15	HK398452	DETECTOR HEAD	KD, KF, KH	1
3-6	ZW206021	'C' Ring, hollow D22	6-1-2	2	3-16	MZ400421	Detector Head Plate	KD-3008	1
3-7x	ZW391476	Set Screw, hexagon socket 4x4(cup)		1	3-17	ZW201475	Screw, pan head 2x3		2
3-8	MS424192	Shaft	KD-7056	1	3-18	MZ467111	Servo, Motor Shield	KD-A1010	2
3-9	MV248130	Bearing 608VVC2E-B32		1	3-19	ZW323728	Screw, binding head 3x5		4
3-10	ZW321592	Washer (SUS)D8.1x13x0.3t		2					
3-11	ZW356883	Washer (Hycar)D8.3x11.8x0.5t		3					

When ordering parts, please describe Parts Number, Serial Number, and Model Number in detail.

FIG. 4 ILLUSTRATION OF OPERATION BLOCK

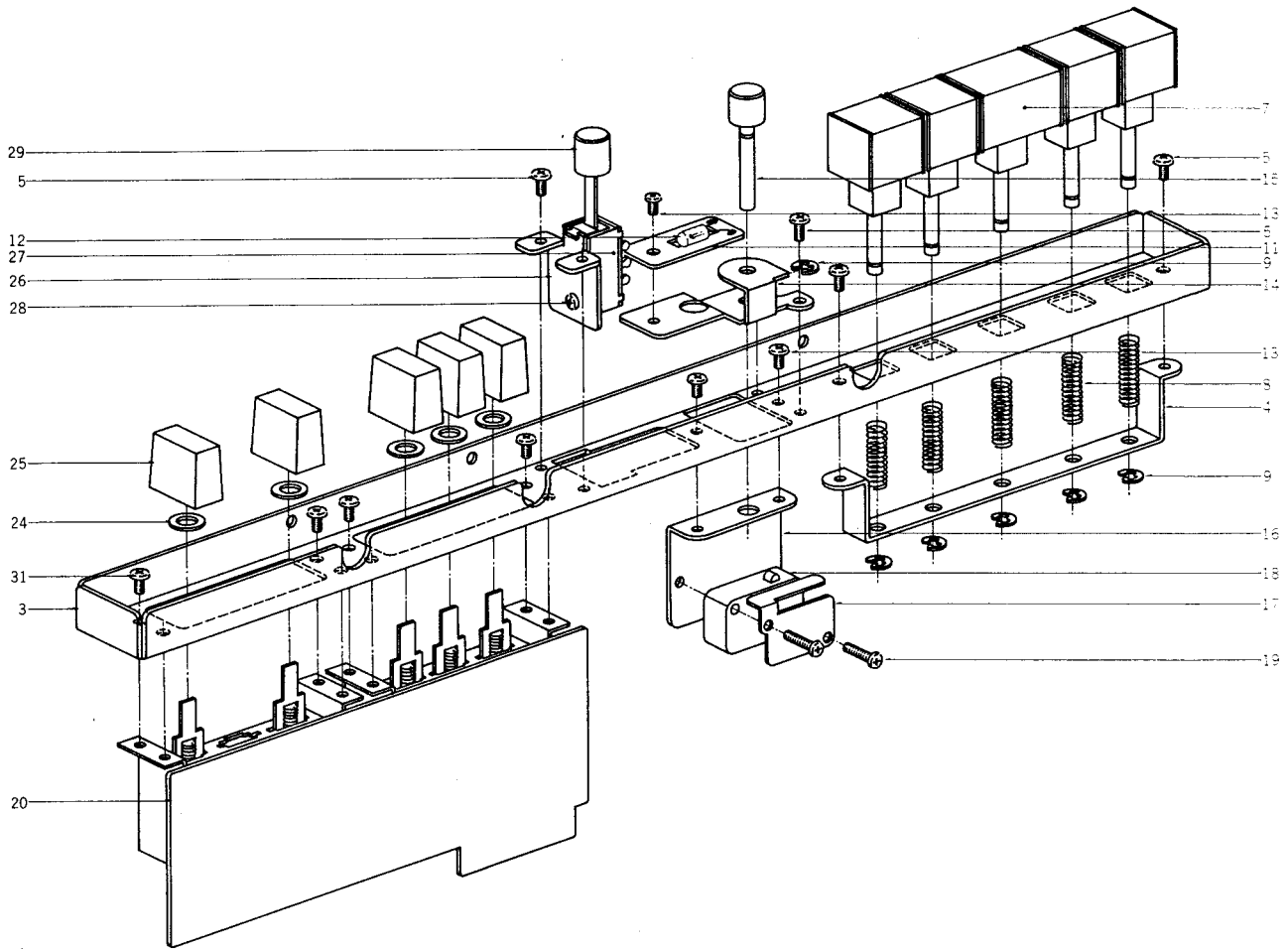

OPERATION BLOCK

Ref. No.	Parts No.	Description	Schematic No.	Q'ty	Ref. No.	Parts No.	Description	Schematic No.	Q'ty
4-1x	BZ465930	Operation Block Comp.	KGA	1	4-19	ZW413785	Screw, binding head 3x12		2
4-2x	BZ426262	Operation Block Comp. (Deck)	KGD	1	4-20	BA467256	Switch P.C. Board Comp.		
4-3	MZ396707	Operation Button Base	KD-2001	1			(KD-A1009)		1
4-4	MZ396674	Operation Button Supporting Base KD-2002		1	4-21x	BA426273	Switch P.C. Board Comp. (KD-A1009) (Deck)		1
4-5	ZW472274	Tapping Screw #2 3x6(bind)		6	4-22x	ZW273778	Earth Lug M3		1
4-6	SB396641	Operation Button A, w/shaft	KD-2007	4	4-23x	ZW379405	ISO Screw, binding head 3x6		6
4-7	SB396652	Operation Button B, w/shaft	KD-2009	1	4-24	ZW403200	Washer (SPC)D6.2x13x1t		5
4-8	ZG428398	Operation Button Spring	KD-2058	5	4-25	SK210521	Push Button Switch Knob	RD-506	5
4-9	ZW270101	'E' Ring 3M	6-1-9	6					
4-10x	MZ396617	Rec. Lamp Base (D)	KD-2012	1	4-26	EZ426723	SRT Switch Base	KD-A2001	1
4-11	EA396898	Neon Lamp P.C. Board	KD-1068	1	4-27	ES374051	Push Switch UEG-22CP	25-26	1
4-12	EL390576	Pilot Lamp RM6-24V-50MA	28-2-6	1	4-28	ZW461935	Screw, round head 2.6x4		3
4-13	ZW323728	Screw, binding head 3x5		3	4-29	SK371621	PTA Knob (black)	ED-615	1
4-14	MZ466108	Rec. Button Table	KD-A2011	1	4-30x	EZ397980	Camouflage Cloth	KD-5029	1
4-15	SB438265	Rec. Button	KF-2015	1	4-31	ZW447772	Tapping Screw #2 3x6(BR)		1
4-16	MZ466097	Micro Switch Table	KD-A2010	1					
4-17	ZG466154	Switch Spring	KD-A2012	1					
4-18	ES250075	Micro Switch V-1A10 U/L	25-1-8	1					

When ordering parts, please describe Parts Number, Serial Number, and Model Number in detail.

FIG. 5 ILLUSTRATION OF MECHANISM ASSEMBLY BLOCK (1)

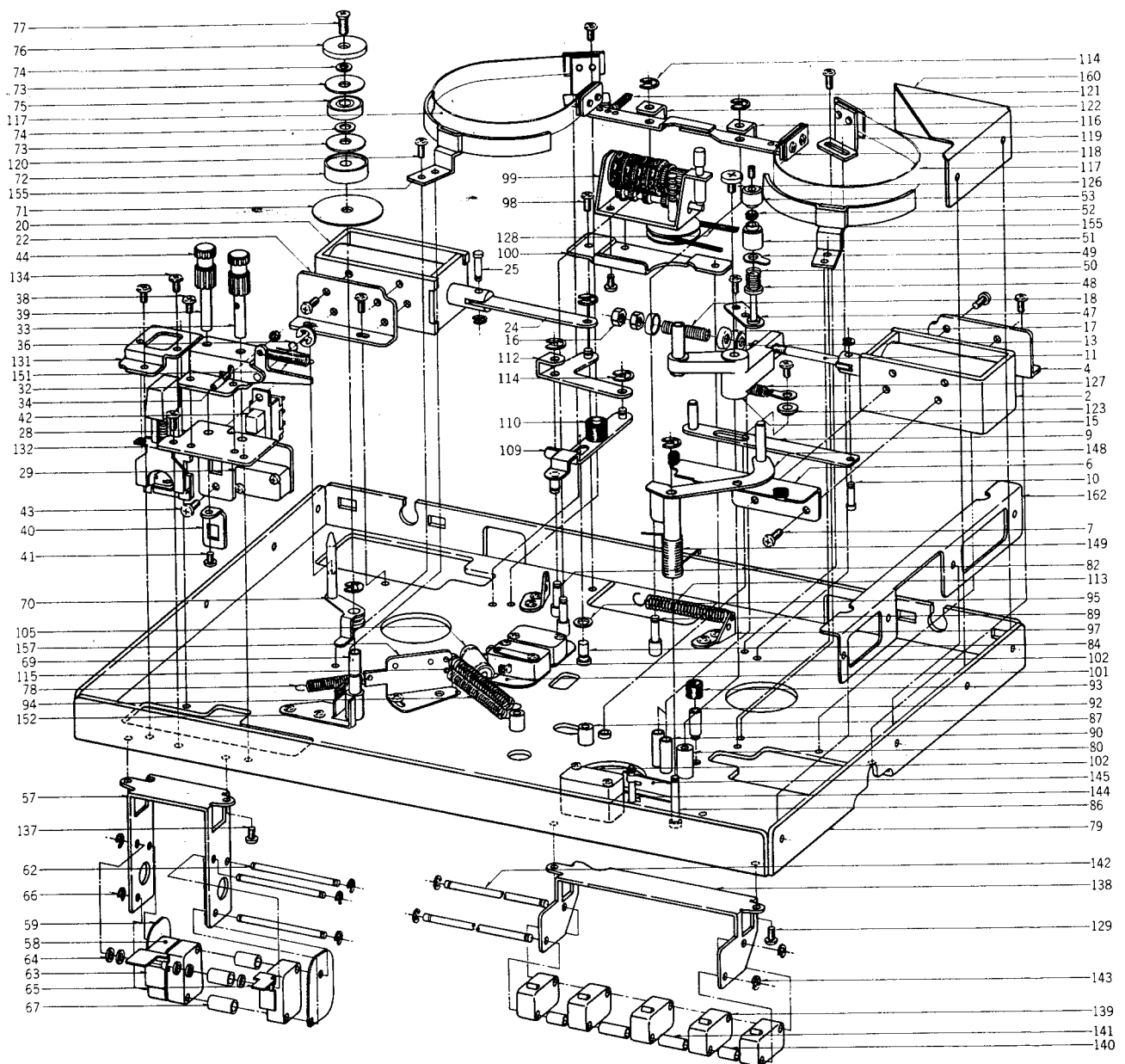

MECHANISM ASSEMBLY BLOCK (1)

Ref. No.	Parts No.	Description	Schematic No.	Q'ty	Ref. No.	Parts No.	Description	Schematic No.	Q'ty
		<b>PINCH ROLLER PLUNGER BLOCK</b>			5-16	ZW273960	Nut M4		2
5-1x	BZ428940	Pinch Roller Plunger Block			5-17	MZ802980	Spring Holder	RD-276	2
		Comp. KG, KA, KF	44-1-45	1	5-18	ZG428927	Pinch Roller Spring B	KD-1032	1
5-2	EP441990	Plunger Solenoid 1660THTI	41-1-36	1			<b>BRAKE PLUNGER BLOCK</b>		
5-3x	ER376424	Spark Quencher U/L			5-19x	BZ398338	Brake Plunger Block Comp.	KD, KF, KH	1
		0.1μ+120 500WV	41-1-36	1	5-20	EP398610	Plunger Solenoid		
5-4	MZ396911	Plunger Bracket	KD-1028	1			SDC-10-M-C-100V	4-1-36	1
5-5x	ZW323728	Screw, binding head 3x5		3	5-21x	ER376424	Spark Quencher U/L		
5-6	MZ396922	Black Mask (2)	KD-1029	1			0.1μ+120 500WV	4-1-36	1
5-7	ZW417137	Screw, binding head 3x4		2	5-22	MZ396911	Plunger Bracket	KD-1028	1
5-8x	MZ428343	KD Stopper Rubber	KD-1068	2	5-23x	MZ201835	Screw, binding head 3x5		4
5-9	MZ396966	Plunger Joint, w/pin C	KD-1033	1	5-24	MZ396977	Brake Plunger Joint	KD-1039	1
5-10	ZW257477	Connecting Pin	RD-211	1	5-25	ZW257477	Connecting Pin	RD-211	1
5-11	MZ396944	Pinch Roller Arm Joint	KD-1031	1	5-26x	ZW270088	'E' Ring 1.9M	4-1-9	1
5-12x	ZW270088	'E' Ring 1.9M	6-1-9	1					
5-13	ZW345442	Washer (Nylon)D4.2x9x1t		1					
5-14x	ZW270101	'E' Ring 3M	6-1-9	1					
5-15	MZ396933	Pinch Roller Arm, w/shaft C	KD-1030	1					

When ordering parts, please describe Parts Number, Serial Number, and Model Number in detail.

Ref. No.	Parts No.	Description	Schematic No.	Q'ty	Ref. No.	Parts No.	Description	Schematic No.	Q'ty
<b>PAUSE &amp; SHUT-OFF SWITCH BLOCK</b>									
5-27x	BZ398340	Pause & Shut-off Switch Block			5-87	HZ397034	Head Base Prop	KD-1005	4
		Comp. KD, KF		1	5-88x	ZW416687	Screw, binding head 4x8		4
5-28	MZ397405	Pause & Shut-off Switch			5-89	MZ317373	Brake Lever Prop	MR-102	2
		Table A	KD-2029	1	5-90	MZ397168	Sensing Base Prop	KD-1062	2
5-29	ES250075	Micro Switch V-1A10 U/L	25-1-8	1	5-91x	ZW413741	Screw, binding head 3x8		6
5-30x	ZW422965	Screw, pan head 3x15		2	5-92	MS217192	Cam Roller Shaft A	900-130	1
5-31x	ER376435	Spark Quencher U/L			5-93	MZ428343	KD Stopper Rubber	KD-1088	2
		0.1μ+120 250WV	4I-1-35	1	5-94	ZG433383	Shifter Spring B	KD-A1008	1
5-32	MZ397416	Pause & Shut-off Switch			5-95	ZW420682	Washer (Nylon)D4.2x9x0.5t		1
		Table B, w/lever	KD-2030	1	5-96x	MZ397045	Sys. Con. Connector Prop	KD-1006	4
5-33	MS397451	Pause Shaft	KD-2036	1	5-97	MZ397080	Spring Rack	KD-1010	2
5-34	MZ397462	Shut-off Switch Pin	KD-2037	1	5-98	ZW323728	Screw, binding head 3x5		6
5-35x	ZW273734	Nut M2		1	5-99	MC399521	Counter M-470D, w/base	9-1-14	1
5-36	ZG397440	Pause Lever Spring	KD-2035	1	5-100	MZ397078	Counter Base	KD-1009	1
5-37x	ZW270123	'E' Ring 4M	6-1-9	1	5-101	MZ250413	Micro Insulator C	RC-127	2
5-38	ZW467908	Screw, pan head 3x4,			5-102	ES250064	Micro Switch V-1A44 U/L	25-1-7	4
		w/washer		2	5-103x	ZW439514	Screw, binding head 3x18		2
5-39	MS397473	Shut-off Shaft	KD-2038	1	5-104x	ZW397146	Micro Switch Nut	KD-1057	1
5-40	MZ397484	Shut-off Switch Plate	KD-2039	1	5-105	EC273464	MP/C. 0.1μF(M) 350WVDC		
5-41	ZW413155	Screw, binding head 3x6		1			(Tub. type)	24-9-4	1
5-42	ES317531	Slide Switch ESD-271DU	25-3-24	1	5-106x	ZW422965	Screw, pan head 3x15		2
5-43	ZW323728	Screw, binding head 3x5		2	5-107x	EZ515158	Micro Insulator E (CSA)	KD-2050	2
5-44	SK397596	Pause & Shut-off Knob	KD-2041	2	5-108x	ZW414066	Screw, binding head 3x25		2
5-45x	ZW434160	Set Screw, hexagon socket			5-109	MZ396832	Brake Slide, w/pins	KD-1044	1
		3x3(cup)		2	5-110	MZ397181	Lever Cushion	KD-1069	1
<b>SENSING GUIDE BLOCK</b>									
5-46x	BZ398362	Sensing Guide Block Comp.	KD, KF	1	5-111x	ZW270101	'E' Ring 3M	6-1-9	1
5-47	MZ396551	Sensing Table, w/prop	KD-2021	1	5-112	ML396742	Brake Lever	KD-1041	1
5-48	MZ396573	Insulator Collar B	KD-2023	1	5-113	ZG465478	Brake Lever Spring	KD-1092	1
5-49	MZ397203	Sensing Pole Terminal Plate	KD-2032	1	5-114	ZW290283	'U' Ring 2.85M	6-1-1	6
5-50	ZG396516	Tape Guide Adjust Spring	KD-2024	1	5-115	ZG407575	Shifter Lever Spring	KD-1078	1
5-51	MZ396527	Sensing Guide B	KD-2025	1	5-116	ML314976	Brake Lever A	MR-210	1
5-52	MZ397214	Insulator Liner A	KD-2031	1	5-117	MB314987	Brake Band	MR-213	2
5-53	MZ397192	Sensing Guide A	KD-2026	1	5-118	MZ314998	Brake Band Retaining Plate	MR-212	4
5-54x	ZW433001	Set Screw, hexagon socket			5-119	MZ315000	Brake Band Support	MR-214	2
		3x5(cup)		1	5-120	ZW323728	Screw, binding head 3x5		12
<b>SPEED CHANGE SWITCH BLOCK</b>									
5-55x	BS423865	Speed Change Switch Block			5-121	ZG315011	Brake Lever Spring	MR-116	2
		Comp. KA, KG		1	5-122	ML396810	Brake Lever B	KD-1038	1
5-56x	BS515430	Speed Change Switch Block			5-123	ZW397157	Graduated Washer	KD-1036	1
		Comp. (CSA)		1	5-124x	ZW273778	Earth Lug M3		1
5-57	MZ397350	Speed Change Switch Stand	KD-2013	1	5-125x	ZW413155	Screw, binding head 3x6		1
5-58	ES250064	Micro Switch V-1A44 U/L	25-1-7	3	5-126	ZW243516	Screw, Pinch Roller	XR-140	1
5-59	MZ402377	Micro Insulator D	KD-2050	2	5-127	ZG208091	Impedance Arm Spring	RD-269	1
5-60x	EZ515158	Micro Insulator E (CSA)	KD-2050	2	5-128	MB303535	Counter Belt D91x1.6	3A-617	1
5-61x	ZW273778	Earth Lug M3		1	5-129	ZW447772	Tapping Screw #2 3x6(BR)		1
5-62	MS397372	Switch Lever Shaft	KD-2015	3	5-130x	MZ515160	Slide Switch Fiber (UL)	KD-A2019	1
5-63	ML397383	Speed Change Switch Lever 2	KD-2016	1	5-131	MZ397394	Power Switch Table	KD-2028	1
5-64	ZW424495	Washer (SPC)D3.1x8x1t		4	5-132	ES246025	Push Switch UEH-12BP U/L	25-5-11	1
5-65	ML403503	Speed Change Switch Lever B	KD-2056	1	5-133x	ES479395	Push Switch TV-3 JH5 (VDE)	25-5-62	1
5-66	ZW270088	'E' Ring 1.9M	6-1-9	6	5-134	ZW371856	ISO Screw, binding head 3x5		2
5-67	MZ397337	Switch Spacer A	KD-2005	3	5-135x	MZ396988	Camouflage Cloth B	KD-1022	1
<b>GUIDE ROLLER BLOCK</b>									
5-68x	BZ434992	Guide Roller Block Comp.	KD, KF	1	5-136x	SK210521	Push Button Switch Knob	RD-506	1
5-69	MS432358	Guide Roller Shaft	KD-A2002	1	5-137	ZW417137	Screw, binding head 3x4		2
5-70	MZ432832	Tension Arm, w/pulley	KD-A2003	1	5-138	MZ397315	Operation Switch Base	KD-2003	1
5-71	MZ434316	Roller Mask	KD-A2005	1	5-139	ES250075	Micro Switch V-1A10 U/L	25-1-8	5
5-72	MZ434970	Tape Guide Table A	KD-A2006	1	5-140	MZ397337	Switch Spacer A	KD-2005	2
5-73	ZW231805	Tape Guide Washer (large)	3A-356	2	5-141	MZ397348	Switch Spacer B	KD-2006	2
5-74	ZW317171	Washer (PBP)D3.1x8x0.1t		2	5-142	MS250165	Micro Switch Shaft B	RD-122B	2
5-75	MV248117	Bearing 635AHZZ-CIE-B32		1	5-143	ZW270088	'E' Ring 1.9M	6-1-9	4
5-76	MZ434981	Tape Guide Table B	KD-A2007	1	5-144	MS408497	Switch Lever Shaft	KD-1080	1
5-77	ZW411660	Screw, oval countersunk head			5-145	ML409083	Micro Switch Lever	KD-1081	2
		3x6		1	5-146x	ZW259683	Washer (Nylon)D3x5x1t		1
5-78	ZG317114	Tension Lever Spring	MR-39	1	5-147x	ZW270088	'E' Ring 1.9M	6-1-9	1
<b>ASSEMBLY BLOCK</b>									
5-79	MZ396990	Mech. Frame	KD-1001	1	5-148	ML396900	Shut-off Lever, w/metal, pole	KD-1052	1
5-80	MS397001	Pinch Roller Arm Shaft	KD-1002	1	5-149	ZG409015	Tension Arm Spring C	KD-1079	1
5-81x	ZW274026	Spring Washer M5		1	5-150x	UM437848	Guide Roller Hole Cover	KD-1089	1
5-82	MS397012	Brake Lever Shaft	KD-1003	1	5-151	ZG366761	Slider Spring	RC-1209	1
5-83x	ZW413188	Nut M4		4	5-152	MZ433721	Stopper	KD-A1006	1
5-84	MS465480	Brake Lever Shaft B	KD-1093	1	5-153x	ZW424124	Screw, countersunk head 3x5		2
5-85x	ZW516611	Nut M3		1	5-154x	EJ331380	Lug Plate KP1L1	33-3-16	1
5-86	MS397023	Tension Arm Shaft	KD-1004	1	5-155	MZ317406	Brake Band Guide, w/base	MR-120	2
					5-156x	MP424023	Pinch Roller (KD)	KD-1084	1
					5-157	MZ434237	KD Spring Rack	KD-A1007	1
					5-158x	ZW413278	Nut M5		1
					5-159x	SZ397517	Corner Angle A (Left)	KD-6003	1
					5-160	SZ397528	Corner Angle B (Right)	KD-6003	1
					5-161x	SZ397530	Side Angle A (Left)	KD-6004	1
					5-162	SZ397541	Side Angle B (Right)	KD-6004	1

When ordering parts, please describe Parts Number, Serial Number, and Model Number in detail.

FIG. 6 PHOTO OF MECHANISM ASSEMBLY BLOCK (2)

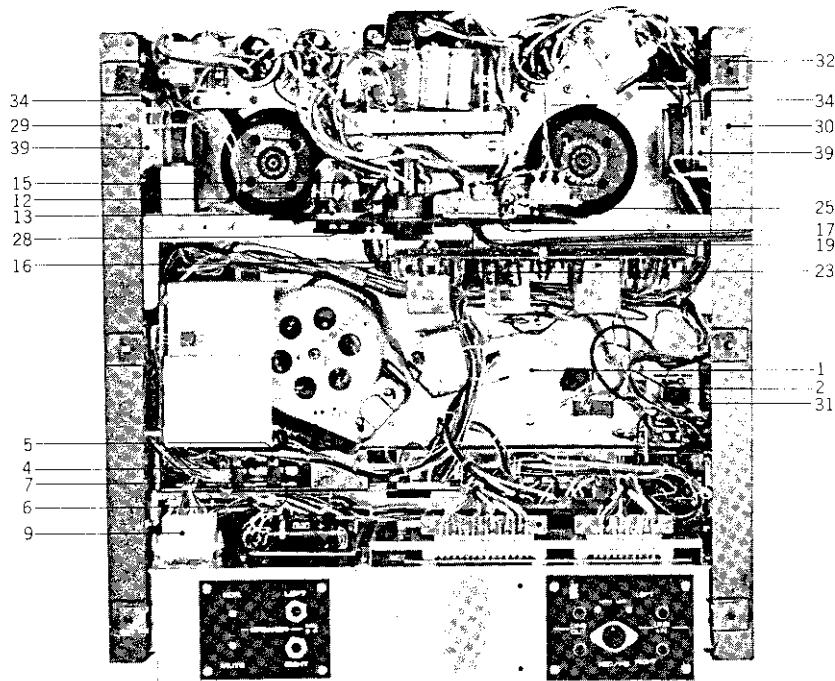

MECHANISM ASSEMBLY BLOCK (2)

Ref. No.	Parts No.	Description	Schematic No.	Q'ty	Ref. No.	Parts No.	Description	Schematic No.	Q'ty
6-1	MZ396990	Mech. Frame	KD-1001	1	6-21x	EZ516464	AC Cord 2.5M (CSA)	26-3-29	1
6-2	ES246025	Push Switch UEH-12BP U/L	25-5-11	1	6-22x	EZ315448	Australia Cord (3 core)	26-3-11	1
6-3x	ES479395	Push Switch TV-3 JH5 (VDE)	25-5-62	1	6-23	EZ382263	Strain Relief SR-4K-4	2-7-12	1
6-4	MZ397315	Operation Switch Base	KD-2003	1	6-24x	EZ246936	Strain Relief SR-6W-1 (3 core)	2-7-8	1
6-5	ES250075	Micro Switch V-1A10 U/L	25-1-8	5	6-25	EZ397124	Cycle Change Switch Plate B	KD-1055	1
6-6	MZ397337	Switch Spacer A	KD-2005	2	6-26x	ZW374128	ISO Screw, truss head 3x8		2
6-7	MZ397348	Switch Spacer B	KD-2006	2	6-27x	ZW447761	Tapping Screw #2 3x6(BR)		4
6-8x	EJ310871	18P Multi-jack J-2			6-28	EJ326430	11P Short Plug A	42-1-25	1
		3250-018-001	31-4-11	2					
6-9	EJ345284	15P Mate-N-Lock Cap Housing			6-29	SZ397495	Side Frame A (Right)	KD-6002	1
		1-480324-0	52-1-6	1	6-30	SZ397506	Side Frame B (Left)	KD-6002	1
6-10x	HZ243191	Pin Contact 60511-1	52-1-1	14	6-31	ZW290248	U type Speed Nut M4 #1 (small)	6-3-1	6
6-11x	EJ450573	9P Mate-N-Lock Cap Housing			6-32	ZW290250	U type Speed Nut M4 #1 (large)	6-3-2	10
		1-480277-0(D)	52-1-7	1	6-33x	MB229138	Wire Bundle Holder N-108		
6-12	EJ222748	Sub Magnale Socket #311SG	31-1-39	1					
6-13	MZ302400	Remote Control Socket Mt.			6-34	SS466143	Speaker 10T-3AP3	2-35-1	1
		Plate RX-515		1				29-5-11	2
6-14x	ZW413741	Screw, binding head 3x8		4	6-35x	ZW413741	Screw, binding head 3x8		8
6-15	EZ397135	Center Frame	KD-1063	1	6-36x	ZW406247	Washer (SUP)D3.2x10x0.5t		8
6-16	EZ397743	P.C. Board Prop	KD-2044	3	6-37x	ZW273745	Spring Washer M3		8
6-17	EZ397293	Connector Plate	KD-2042	1	6-38x	ZW273756	Nut M3		8
6-18x	EZ515485	Connector Plate (CSA,UL)	KD-A2015	1	6-39	ER467054	Cement/R. 2W 8Ω(K)		
6-19	EZ383938	U/L AC Cord 3M	26-3-20	1			(Wire-wound type)	35-16-1	2
6-20x	EZ486797	Power Supply Cord (VDE)	26-3-26	1					

When ordering parts, please describe Parts Number, Serial Number, and Model Number in detail.

FIG. 7 PHOTO OF REC. AMP. P.C. BOARD (KD-A5011)

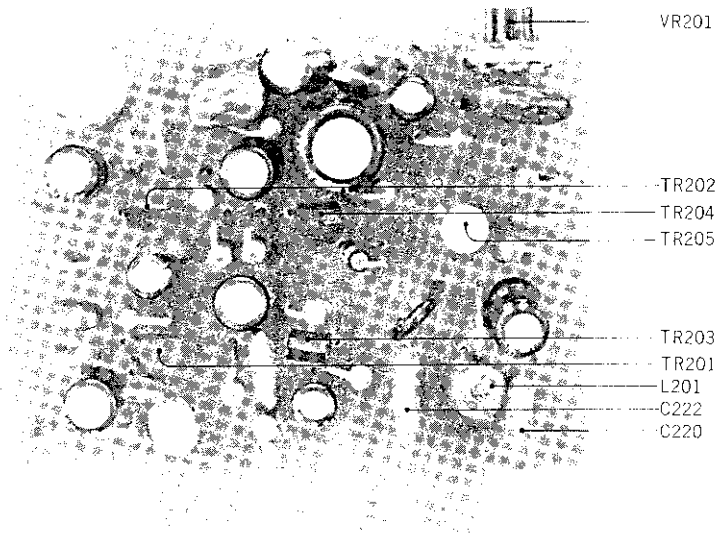

REC. AMP. P.C. BOARD (KD-A5011) BLOCK

Symbol No.	Parts No.	Description	Q'ty	Symbol No.	Parts No.	Description	Q'ty
7-1x	BA426330	Rec. Amp. P.C. Board Comp. (KD-A5011)	1	<b>Resistor, Stopper Type</b>			
7-TR201, 2	ET398845	Transistor 2SC871(E)(F)	2	7-R201	ER336442	Carbon RD1/4 10k(J)	1
7-TR203	ET234843	Transistor 2SC458LG(B)(C)	1	7-R202	ER362485	Carbon RD1/4 330(J)	1
7-TR204	ET379462	Transistor 2SC711(D)(E)	1	7-R203	ER336442	Carbon RD1/4 10k(J)	1
7-TR205	ET338894	Transistor 2SC968(3)	1	7-R204	ER304402	Carbon RD1/4 470(J)	1
7-VR201	EV398812	Semi-fixed Volume V10K-5 5 kB	1	7-R205	ER357570	Carbon RD1/4 150(J)	1
7-L201	EO321254	Ferri Inductor FL7H 5.6MH(J)	1	7-R206	ER346994	Carbon RD1/4 18k(J)	1
		<b>Capacitor, Vertical Type</b>		7-R207	ER306360	Carbon RD1/4 6.8k(J)	1
7-C201	EC432810	Elect. 10 $\mu$ F 16WV(NL)	1	7-R208	ER357456	Carbon RD1/4 2.2k(J)	1
7-C202	EC383501	Mylar 0.001 $\mu$ F(M) 50WV	1	7-R209	ER212264	Carbon RD1/4 22k(J)	1
7-C203	EC329771	Elect. 47 $\mu$ F 6.3WV	1	7-R210	ER212883	Carbon RD1/4 4.7k(J)	1
7-C204	EC399690	VFM 33PF(J) 50WV	1	7-R211	ER336442	Carbon RD1/4 10k(J)	1
7-C205	EC320051	Elect. 10 $\mu$ F 16WV	1	7-R212	ER450011	Carbon RD1/4 120(J)	1
7-C206	EC329771	Elect. 47 $\mu$ F 6.3WV	1	7-R213	ER349942	Carbon RD1/4 8.2k(J)	1
7-C207	EC407272	VFM 100PF(M) 50WV	1	7-R214	ER211465	Carbon RD1/4 1k(J)	1
7-C208	EC476965	Elect. 47 $\mu$ F 25WV(NL)	1	7-R215	ER211757	Carbon RD1/4 100(J)	1
7-C209	EC320051	Elect. 10 $\mu$ F 16WV	1	7-R216	ER212883	Carbon RD1/4 4.7k(J)	1
7-C210	EC407114	VFM 220PF(M) 50WV	1	7-R217	ER362441	Carbon RD1/4 1.8k(J)	1
7-C211	EC329771	Elect. 47 $\mu$ F 6.3WV	1	7-R218	ER213300	Carbon RD1/4 680(J)	1
7-C213	EC368370	Mylar 0.15 $\mu$ F(J) 50WV	1	7-R219	ER342933	Carbon RD1/4 27k(J)	1
7-C214	EC329771	Elect. 47 $\mu$ F 6.3WV	1	7-R220	ER361528	Carbon RD1/4 56k(J)	1
7-C215	EC220994	Elect. 10 $\mu$ F 25WV	1	7-R221	ER212264	Carbon RD1/4 22k(J)	1
7-C216	EC379170	Mylar 0.1 $\mu$ F(J) 50WV	1	7-R222	ER212883	Carbon RD1/4 4.7k(J)	1
7-C217	EC220678	Elect. 47 $\mu$ F 25WV	1	7-R223	ER212681	Carbon RD1/4 330(J)	1
7-C218	EC320051	Elect. 10 $\mu$ F 16WV	1	7-R224	ER211858	Carbon RD1/4 12k(J)	1
7-C220	EC337487	Hi-Q 470PF(J) 50WV	1	7-R225	ER352045	Carbon RD1/4 3.9k(J)	1
7-C221	EC220994	Elect. 10 $\mu$ F 25WV	1	7-R226	ER211465	Carbon RD1/4 1k(J)	1
7-C222	EC337487	Hi-Q 470PF(J) 50WV	1	7-R227	ER349784	Carbon RD1/4 390(J)	1
7-C224	EC379765	Mylar 0.0027 $\mu$ F(J) 50WV	1				

FIG. 8 PHOTO OF P.B. AMP. P.C. BOARD  
(KD-A5010)

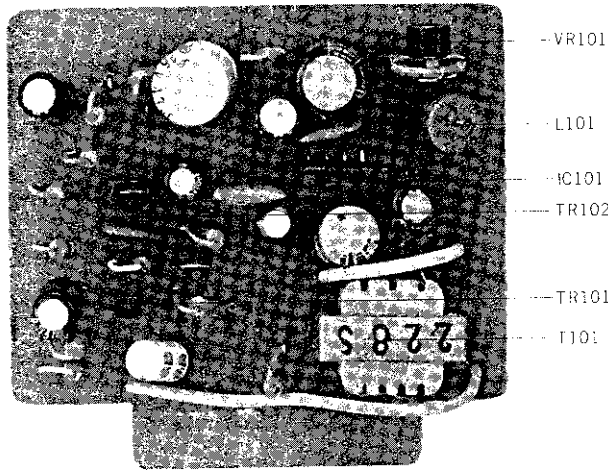

P.B. AMP. P.C. BOARD (KD-A5010) BLOCK

Symbol No.	Parts No.	Description	Q'ty
8-1x	BA426341	P.B. Amp. P.C. Board Comp. (KD-A5010)	1
8-IC101	EI412413	Line Amp. I.C. LD-3141	1
8-TR101, 2	ET398845	Transistor 2SC871(E)(F)	2
8-T101	BT247746	Head Phone Trans. N19-228S	1
8-L101	EO244001	Ferri Inductor FL9H 10MH(J)	1
8-VR101	EV221850	Semi-fixed Volume V10K-5 20 kB	1
<b>Capacitor, Vertical Type</b>			
8-C101	EC432810	Elect. 10 $\mu$ F 16WV(NL)	1
8-C103	EC329771	Elect. 47 $\mu$ F 6.3WV	1
8-C104	EC290520	VFM 100PF(J) 50WV	1
8-C105	EC320051	Elect. 10 $\mu$ F 16WV	1
8-C106	EC329771	Elect. 47 $\mu$ F 6.3WV	1
8-C107	EC476965	Elect. 47 $\mu$ F 25WV(NL)	1
8-C109	EC250841	Mylar 0.01 $\mu$ F(J) 50WV	1
8-C110	EC290564	VFM 220PF(K) 50WV	1
8-C111	EC320051	Elect. 10 $\mu$ F 16WV	1
8-C112	EC220678	Elect. 47 $\mu$ F 25WV	1
8-C113	EC329771	Elect. 47 $\mu$ F 6.3WV	1
8-C114	EC329850	VFM 220PF(J) 50WV	1
8-C115	EC220364	Elect. 100 $\mu$ F 6.3WV	1
8-C116	EC220994	Elect. 10 $\mu$ F 25WV	1
<b>Resistor, Stopper Type</b>			
8-R101, 2	ER362485	Carbon RD1/4 330k(J)	2
8-R103	ER336442	Carbon RD1/4 10k(J)	1
8-R104	ER212681	Carbon RD1/4 330(J)	1
8-R105	ER212264	Carbon RD1/4 22k(J)	1
8-R106	ER212477	Carbon RD1/4 3.3k(J)	1
8-R107	ER357570	Carbon RD1/4 150k(J)	1
8-R108	ER212883	Carbon RD1/4 4.7k(J)	1
8-R109	ER211858	Carbon RD1/4 12k(J)	1
8-R110	ER380711	Carbon RD1/4 220k(J)	1
8-R111	ER212264	Carbon RD1/4 22k(J)	1
8-R112	ER212883	Carbon RD1/4 4.7k(J)	1

SERVO P.C. BOARD (KD-1096) BLOCK

Symbol No.	Parts No.	Description	Q'ty
9-1x	BA423876	Servo P.C. Board Comp. (KD-1096)	1
9-2x	BA515441	Servo P.C. Board Comp. (KD-1096) (D-CSA)	1
9-3x	BA515452	Servo P.C. Board B Comp. (KD-1096)(D-UL)	1
9-TR201	ET379462	Transistor 2SC711(D)(E)	1
9-TR202	ET356984	Transistor 2SA564(R)	1
9-TR203, 4	ET379462	Transistor 2SC711(D)(E)	2
9-TR205	ET356984	Transistor 2SA564(R)	1
9-TR206	ET398777	Transistor 2SC711(G)(F)	1
9-TR207	ET379462	Transistor 2SC711(D)(E)	1
9-TR208	ET399936	Transistor 2SC945(R)(S)	1
9-TR209	ET403042	Transistor 2SD234(Y)	1
9-TR251	ET393581	Transistor 2SC1014(D)(E)	1
9-TR252	ET403042	Transistor 2SD234(Y)	1
9-TR253	ET391138	Transistor 2SC968(3)(4)	1
9-TH201	ED321390	Thermister 41D26	1
9-D201, 2	ED224526	Silicon Diode 10D1	2
9-D204	ED224526	Silicon Diode 10D1	1
9-D251	ED329130	Silicon Diode 10DC-1(black)	1
9-D252	ED329128	Silicon Diode 10DC-1(red)	1
9-D253	ED520762	Zener Diode YZ-088A	1
9-VR202	EV499364	Semi-fixed Volume V10K8-4-2 5 kB	1
9-VR251	EV398834	Semi-fixed Volume V10K5-2-4 1 kB	1
9-VR251	EV484863	Semi-fixed Volume V10K8-4-2 1 kB (UL)	1

When ordering parts, please describe Parts Number, Serial Number, and Model Number in detail.

FIG. 9 PHOTO OF SERVO P.C. BOARD (KD-1096)

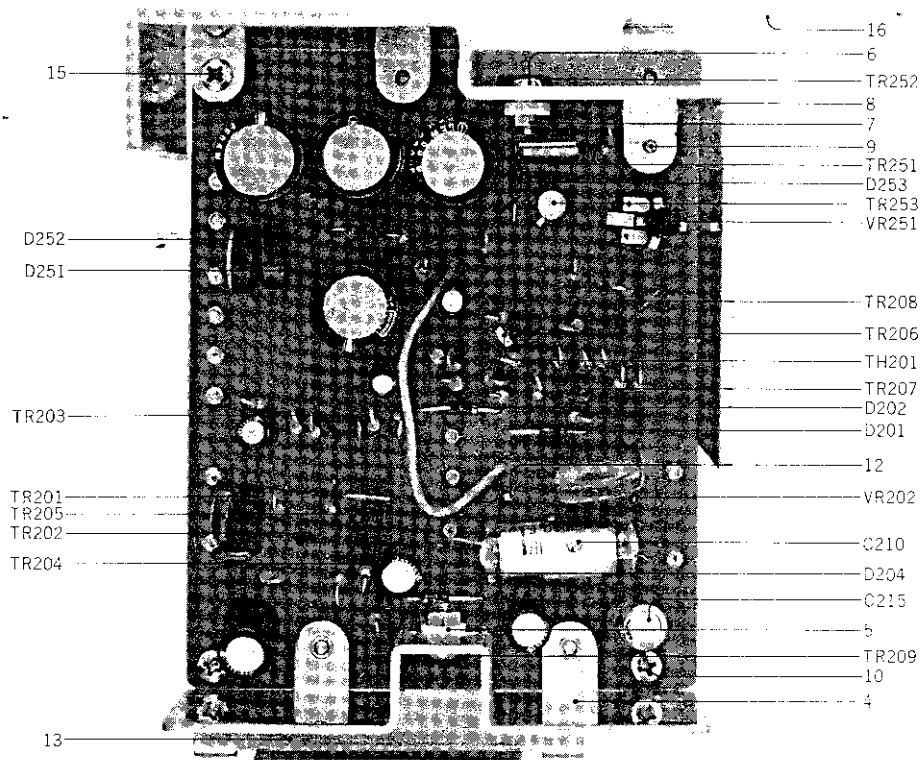

Symbol No.	Parts No.	Description	Q'ty	Symbol No.	Parts No.	Description	Q'ty
9-FR1	EF515305	Fuse/R. FRN1/4 47(J) 20MA (CSA)	1	9-C215	EC517116	Tantalum 33 $\mu$ F(M) 10WV (DTS type)	1
9-FR2	EF515316	Fuse/R. FRN1/4 10(K) 20MA (CSA)	1	9-C251, 2	EC403468	Elect. 330 $\mu$ F 50WV	2
9-FR3	EF515327	Fuse/R. FRN1/2 47(J) 50MA (CSA)	1	9-C253	EC372148	Elect. 220 $\mu$ F 35WV	1
9-4	EZ407586	Heat-sink Plate B	1	9-C254	EC331817	Elect. 470 $\mu$ F 25WV	1
9-5	ZW392940	Insulator Washer 1 G-473025-1	2	9-C255	EC350684	Elect. 22 $\mu$ F 25WV	1
9-6	ZW421806	Screw, pan head 3x8	2	9-C256	EC250918	Mylar 0.01 $\mu$ F(M) 50WV	1
9-7	ZW273756	Nut M3	4	<b>Resistor, Stopper Type</b>			
9-8	EZ405213	Heat-sink Plate	1	9-R201	ER336442	Carbon RD1/4 10k(J)	1
9-9	ZW200687	Tapping Screw #2 3x6(round)	2	9-R202	ER362441	Carbon RD1/4 1.8k(J)	1
9-10	ZW413741	Screw, binding head 3x8	2	9-R203	ER357456	Carbon RD1/4 2.2k(J)	1
9-11x	ZW273802	Toothed Lock Washer M3	1	9-R204	ER212264	Carbon RD1/4 22k(J)	1
9-12	EZ380428	F3 Type Pin	2	9-R205,6,7	ER336442	Carbon RD1/4 10k(J)	3
9-13	EZ397721	Servo P.C. Board Retaining Plate	1	9-R208	ER361642	Carbon RD1/4 47(J)	1
9-14x	EZ397743	P.C. Board Prop	4	9-R209	ER211757	Carbon RD1/4 100k(J)	1
9-15	ZW413155	Screw, binding head 3x6	3	9-R210	ER357456	Carbon RD1/4 2.2k(J)	1
9-16	EZ397732	Bracket	1	9-R211	ER212016	Carbon RD1/4 150(J)	1
9-17x	ZW417025	Screw, binding head 3x8, w/washer	1	9-R211	ER212681	Carbon RD1/4 330(J) (CSA)	1
9-18x	ZW273778	Earth Lug M3	1	9-R212	ER403187	Carbon RD1/4 10k(F) (P type)	1
9-19x	ZW413728	Screw, binding head 3x6, w/washer	4	9-R213	ER403097	Carbon RD1/4P 9.1k(F) (P type)	1
		<b>Capacitor, Vertical Type</b>		9-R214	ER212883	Carbon RD1/4 4.7k(J)	1
9-C201	EC398957	Mylar 0.1 $\mu$ F(M) 50WV	1	9-R217	ER306887	Carbon RD1/4 15k(J)	1
9-C202	EC251190	Mylar 0.056 $\mu$ F(K) 50WV	1	9-R218	ER212883	Carbon RD1/4 4.7k(J)	1
9-C203	EC331705	Elect. 22 $\mu$ F 16WV	1	9-R218	ER212883	Carbon RD1/4 4.7k(J)	1
9-C204	EC379787	Mylar 0.0039 $\mu$ F(J) 50WV	1	9-R219	ER357456	Carbon RD1/4 2.2k(J)	1
9-C205	EC320051	Elect. 10 $\mu$ F 16WV	1	9-R220	ER211667	Carbon RD1/4 100(J)	1
9-C206	EC250661	Mylar 0.0015 $\mu$ F(K) 50WV	1	9-R221	ER213030	Carbon RD1/4 5.6k(J)	1
9-C207	EC220151	Elect. 100 $\mu$ F 25WV	1	9-R222, 3	ER357456	Carbon RD1/4 2.2k(J)	2
9-C208	EC350684	Elect. 22 $\mu$ F 25WV	1	9-R224, 5	ER211465	Carbon RD1/4 1k(J)	2
9-C209	EC329850	VFM 220PF(J) 50WV	1	9-R226	ER304290	Carbon RD1/4 10(J)	1
9-C210	EC424080	Styrol 0.051 $\mu$ F(F) 50WV (Tub. type)	1	9-R227	ER306887	Carbon RD1/4 15k(J)	1
9-C211	EC438524	Mylar 0.27 $\mu$ F(H) 100WV	1	9-R228	ER424078	Carbon RD1/4 51(J)	1
9-C213	EC220432	Elect. 2.2 $\mu$ F 25WV	1	9-R251	ER357456	Carbon RD1/4 2.2k(J)	1
				9-R252	ER212681	Carbon RD1/4 330(J)	1
				9-R253	ER343078	Carbon RD1/4 2.7k(J)	1
				9-R254	ER357456	Carbon RD1/4 2.2k(J)	1
				9-R255	ER306843	Carbon RD1/4 1.2k(J)	1
				9-R256	ER538547	Carbon RD1/2W 47(J) (Insu. type)	1

When ordering parts, please describe Parts Number, Serial Number, and Model Number in detail.



FIG. 10 PHOTO OF SYS. CON. P.C. BOARD (KD-A1001A)

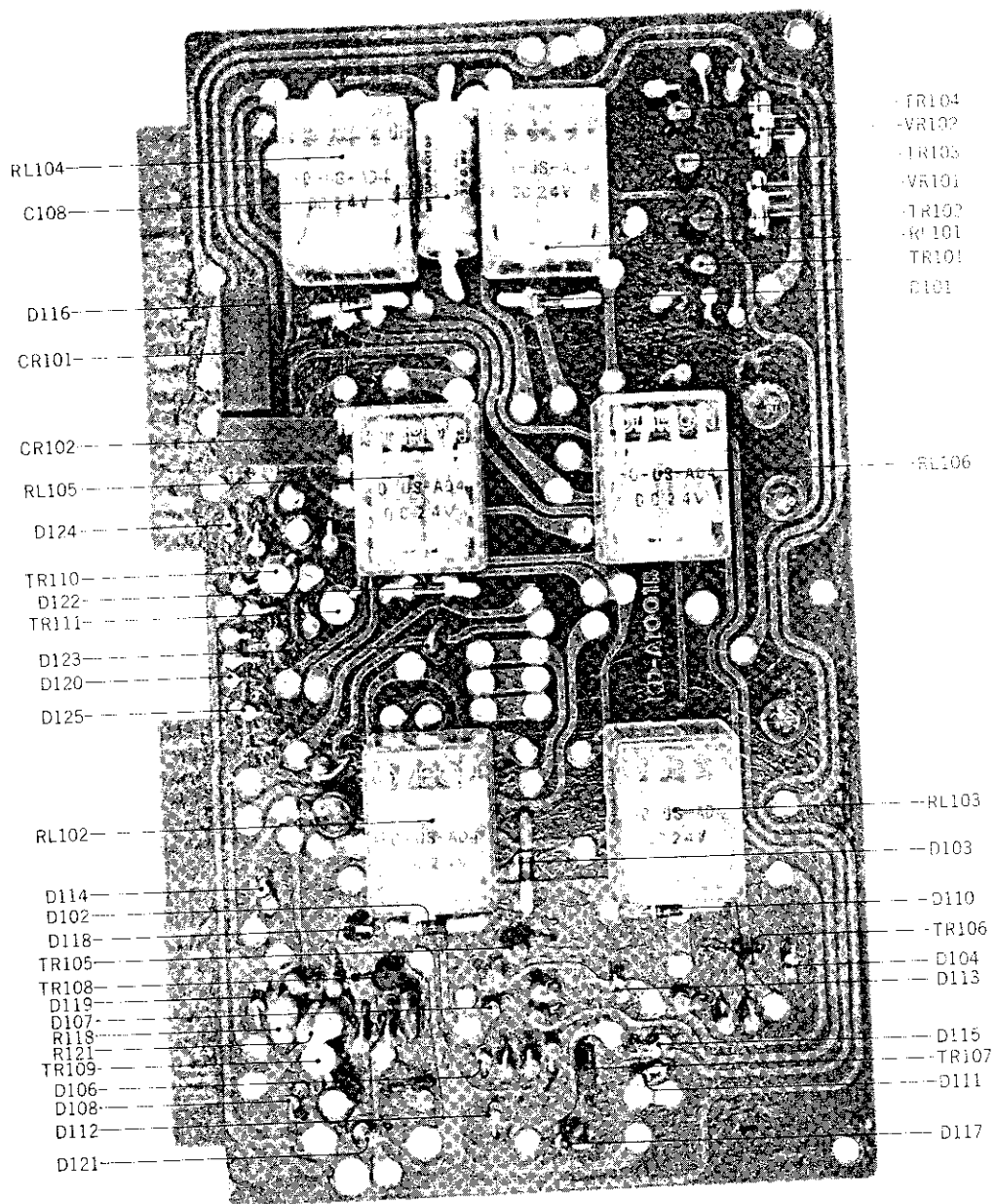

**SYS. CON. P.C. BOARD  
(KD-A1001A) BLOCK**

Symbol No.	Parts No.	Description	Q'ty
10-1x	BA426284	Sys. Con P.C. Board Comp. (KD-A1001A)	1
10-TR101 to 8	ET398711	Transistor 2SC945(Q)(R)	8
10-TR109 to 11	ET338894	Transistor 2SC968(3)	3
10-D101,2,3	ED224526	Silicon Diode 10D1	3
10-D104	ED219464	Germanium Diode 1N34A	1
10-D106,7,8	ED219464	Germanium Diode 1N34A	3
10-D110	ED224526	Silicon Diode 10D1	1
10-D111 to 15	ED219464	Germanium Diode 1N34A	5
10-D116 to 19	ED224526	Silicon Diode 10D1	4
10-D120 to 22	ED219464	Germanium Diode 1N34A	3
10-D123	ED224550	Silicon Diode 10D4	1
10-D124, 5	ED219464	Germanium Diode 1N34A	2
10-D126	ED224526	Silicon Diode 10D1	1
10-D127	ED224550	Silicon Diode 10D4	1
10-RL101 to 6	EP344136	Relay MY4-O-US-AD4-24V	6
10-CR101, 2	ER376424	Spark Quencher U/L 0.1μ+120 500WV	2
10-VR101	EV426936	Semi-fixed Volume V10K-5 30 kB	1
10-VR102	EV221826	Semi-fixed Volume V10K-5 10 kB	1
<b>Capacitor, Vertical Type</b>			
10-C101, 2	EC456041	Elect. 33μF 25WV	2
10-C103	EC220612	Elect. 33μF 25WV	1
10-C104	EC308711	Mylar 0.047μF(K) 50WV	1
10-C105, 6, 7	EC220994	Elect. 10μF 25WV	3
10-C108	EC273464	MP 0.1μF(M) 350WVDC (Tub. type)	1
10-C109	EC220612	Elect. 33μF 25WV	1
10-C110	EC220994	Elect. 10μF 25WV	1
<b>Resistor, Stopper Type</b>			
10-R101	ER211465	Carbon RD1/4 1k(J)	1
10-R102	ER362485	Carbon RD1/4 330k(J)	1
10-R103	ER336442	Carbon RD1/4 10k(J)	1
10-R104, 5	ER212883	Carbon RD1/4 4.7k(J)	2
10-R106	ER362485	Carbon RD1/4 330k(J)	1
10-R107	ER212883	Carbon RD1/4 4.7k(J)	1
10-R108	ER211465	Carbon RD1/4 1k(J)	1
10-R109	ER212883	Carbon RD1/4 4.7k(J)	1
10-R110	ER357456	Carbon RD1/4 2.2k(J)	1
10-R111	ER343078	Carbon RD1/4 2.7k(J)	1
10-R112	ER212883	Carbon RD1/4 4.7k(J)	1
10-R113	ER357456	Carbon RD1/4 2.2k(J)	1
10-R114	ER343078	Carbon RD1/4 2.7k(J)	1
10-R115	ER212883	Carbon RD1/4 4.7k(J)	1
10-R116	ER357456	Carbon RD1/4 2.2k(J)	1
10-R117	ER343078	Carbon RD1/4 2.7k(J)	1
10-R118	ER391623	Metal Oxide Film 1W 1k(K)	1
10-R119	ER357456	Carbon RD1/4 2.2k(J)	1
10-R120	ER213300	Carbon RD1/4 680(J)	1
10-R121	ER391623	Metal Oxide Film 1W 1k(K)	1
10-R122	ER539065	Carbon RD1/4 1.6k(K)	1
10-R123	ER213300	Carbon RD1/4 680(J)	1
10-R124	ER211667	Carbon RD1/4 100(J)	1
10-R125	ER336442	Carbon RD1/4 10k(J)	1
10-R126, 7	ER211465	Carbon RD1/4 1k(J)	2
10-R128	ER212883	Carbon RD1/4 4.7k(J)	1
10-R129	ER213030	Carbon RD1/4 5.6k(J)	1
10-R130	ER211465	Carbon RD1/4 1k(J)	1
10-R131	ER336442	Carbon RD1/4 10k(J)	1
10-R132	ER211465	Carbon RD1/4 1k(J)	1
10-R133	ER380147	Carbon RD1/4 10(J) (Insu. type)	1
10-R134	ER304290	Carbon RD1/4 10(J)	1

**FIG. 11 PHOTO OF OSC. P.C. BOARD  
(KD-A5004)**

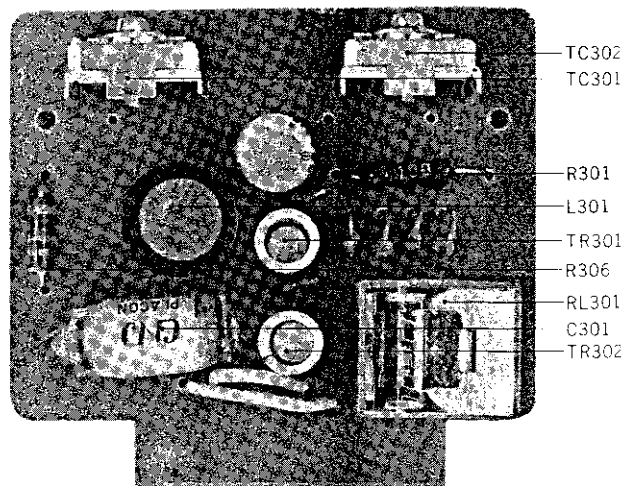

**OSC. P.C. BOARD (KD-A5004) BLOCK**

Symbol No.	Parts No.	Description	Q'ty
11-1x	BA426352	OSC. P.C. Board Comp. (KD-A5004)	1
11-TR301, 2	ET304255	Transistor 2SC971(2)(3) (red)	2
11-L301	EO383365	OSC. Coil OT-204	1
11-RL301	EP383321	Relay TECK-36 DC22V1000	1
11-TC301, 2	EC425250	Trimmer/C. A-1P3-3 70PF	2
<b>Capacitor, Vertical Type</b>			
11-C301	EC520492	Styrol 5600PF(J) 500WV (Tub. type)	1
11-C302	EC220678	Elect. 47μF 25WV	1
11-C303, 4	EC250841	Mylar 0.01μF(J) 50WV	2
<b>Resistor, Stopper Type</b>			
11-R301	ER398856	Metal Oxide Film 1W 100(K)	1
11-R302	ER212883	Carbon RD1/4 4.7k(J)	1
11-R303	ER304402	Carbon RD1/4 470(J)	1
11-R304, 5	ER315944	Carbon RD1/4 3.3(J)	2
11-R306	ER426892	Solid RC1/2 2.4k(J)	1

FIG. 12 PHOTO OF MAIN AMP.  
P.C. BOARD (KD-A5015)

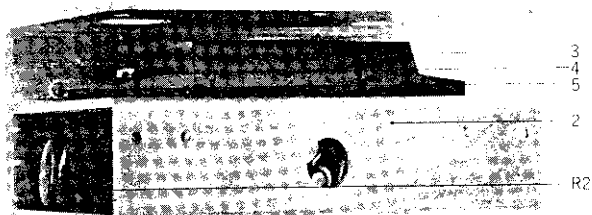

MAIN AMP. P.C. BOARD  
(KD-A5015) BLOCK

Symbol No.	Parts No.	Description	Q'ty
12-1x	BA465952	Main Amp. P.C. Board Comp. (KD-A5015)	1
12-2	BC371428	Power Amp. Case	1
12-3	EI466075	Power Amp. I.C. EHD-AP4153P	1
12-4	ZW375085	Tapping Screw #2 2.6x12(round)	2
12-5	ZW447772	Tapping Screw #2 3x6(BR)	2
Capacitor, Vertical Type			
12-C1	EC220994	Elect. 10 $\mu$ F 25WV	1
12-C2	EC290564	VFM 220PF(K) 50WV	1
12-C3	EC220678	Elect. 47 $\mu$ F 25WV	1
12-C4	EC220151	Elect. 100 $\mu$ F 25WV	1
12-C5, 6	EC220678	Elect. 47 $\mu$ F 25WV	2
12-C7, 8	EC220994	Elect. 10 $\mu$ F 25WV	2
12-C9	EC334620	Mylar 0.22 $\mu$ F(K) 50WV	1
Resistor, Stopper Type			
12-R1	ER363644	Carbon RD1/4 560(J)	1
12-R2	ER332212	Solid RC1/2 10(K)	1

FIG. 13 PHOTO OF SWITCH P.C. BOARD (KD-A1009)

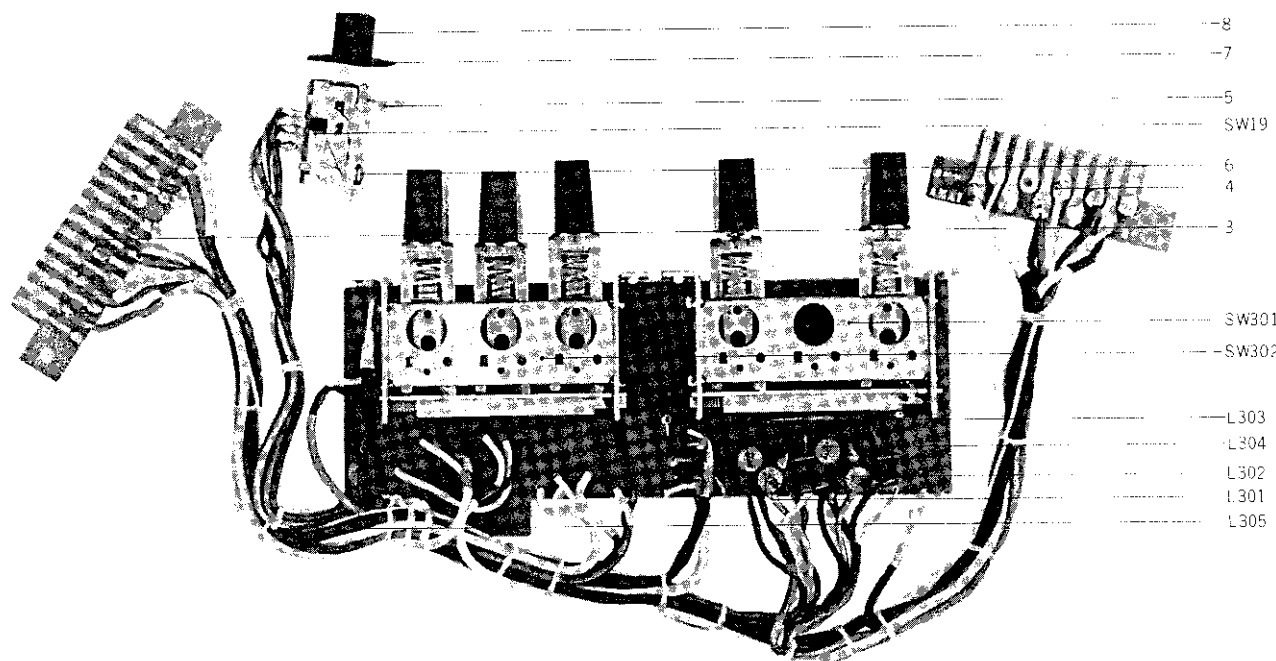

SWITCH P.C. BOARD (KD-A1009) BLOCK

Symbol No.	Parts No.	Description	Q'ty	Symbol No.	Parts No.	Description	Q'ty
13-1x	BA467256	Switch P.C. Board Comp. (KD-A1009)	1	Capacitor, Vertical Type			
13-2x	BA426273	Switch P.C. Board Comp. (KD-A1009) (Deck)	1	13-C301	EC379192	Mylar 0.039 $\mu$ F(J) 50WV	1
13-SW301	ES424146	Push Switch TUM 31218K	1	13-C302	EC250975	Mylar 0.015 $\mu$ F(J) 50WV	1
13-SW302	ES448053	Push Switch SPT-034A13	1	13-C303	EC411827	Mylar 0.0082 $\mu$ F(J) 50WV	1
13-L301, 2	EO243977	Ferri Inductor FL7H 1MH(J)	2	13-C304	EC379192	Mylar 0.039 $\mu$ F(J) 50WV	1
13-L303, 4	EO458932	Ferri Inductor FL7H 2.2MH(J)	2	13-C305	EC250975	Mylar 0.015 $\mu$ F(J) 50WV	1
13-L305	EO346500	Ferri Inductor FL7H 220 $\mu$ H(J)	1	13-C306	EC411827	Mylar 0.0082 $\mu$ F(J) 50WV	1
13-3	EA222096	Connector P.C. Board	1	Resistor, Stopper Type			
13-4	EA382713	Head Connector P.C. Board	1	13-R301	ER306360	Carbon RD1/4 6.8k(J)	1
13-5	EZ426723	SRT Switch Base	1	13-R302, 3	ER346601	Carbon RD1/4 47k(J)	2
13-SW19	ES374051	Push Switch UEG-22CP	1	13-R304	ER306360	Carbon RD1/4 6.8k(J)	1
13-6	ZW461935	Screw, round head 2.6x4	1	13-R305, 6	ER362441	Carbon RD1/4 1.8k(J)	2
13-7	EZ397980	Camouflage Cloth	1				
13-8	SK371621	PTA Knob (black)	1				

When ordering parts, please describe Parts Number, Serial Number, and Model Number in detail.

FIG. 14 PHOTO OF PRE AMP. CHASSIS  
P.C. BOARD (KD-5027)

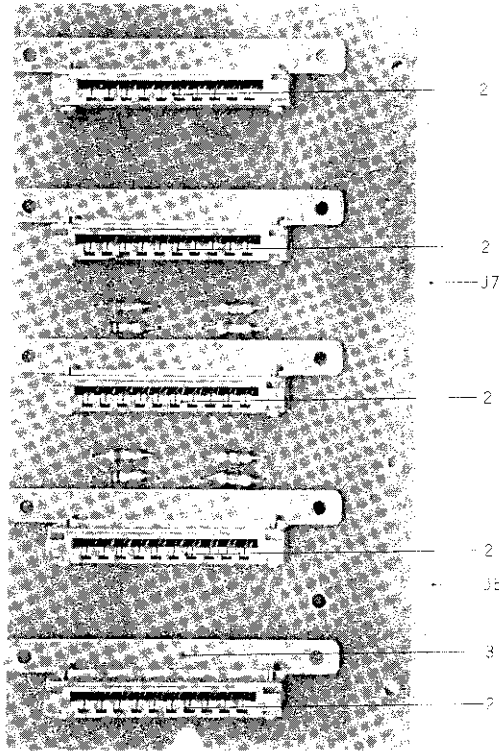

PRE AMP. CHASSIS  
P.C. BOARD (KD-5027) BLOCK

Symbol No.	Parts No.	Description	Q'ty
14-1x	BA398542	Pre Amp. Chassis P.C. Board Comp. (KD-5027)	1
14-2	EJ398733	10P Multi-jack 500-010-098	5
14-3	EZ397866	Multi Jack Mt. Angle	5
14-4x	ZW364397	Screw, pan head 2.3x10	10
14-J5	EJ292926	10P Multi-jack 3250-010-098	1
14-J7	EJ293084	14P Multi-jack-1 3250-014-098	1
		<b>Resistor, Insulator Type</b>	
14-R401	ER329308	Carbon RD1/4 47k(J)	1
14-R402	ER213715	Carbon RD1/4 100k(J)	1
14-R403,4,5	ER329308	Carbon RD1/4 47k(J)	3
14-R406	ER213715	Carbon RD1/4 100k(J)	1
14-R407, 8	ER329308	Carbon RD1/4 47k(J)	2

FIG. 15 PHOTO OF TONE CONTROL  
P.C. BOARD (MS-5028)

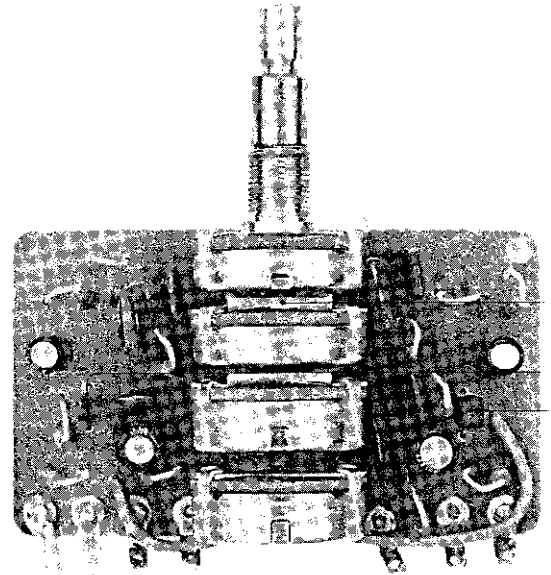

TONE CONTROL  
P.C. BOARD (MS-5028) BLOCK

Symbol No.	Parts No.	Description	Q'ty
15-1x	BA466277	Tone Control P.C. Board Comp. (MS-5028)	1
15-TR701	ET398711	Transistor 2SC945(Q)(R)	2
15-VR701	EV424743	Dual-axial 4-throw Volume KJ-60R 50 kAx4	1
		<b>Capacitor, Vertical Type</b>	
15-C701	EC320051	Elect. 10 $\mu$ F 16WV	2
15-C702	EC220994	Elect. 10 $\mu$ F 25WV	2
15-C703	EC368335	Mylar 0.0022 $\mu$ F(J) 50WV	2
15-C704	EC250683	Mylar 0.0022 $\mu$ F(J) 50WV	2
15-C705	EC438041	Mylar 0.082 $\mu$ F(J) 50WV	2
15-C706	EC329861	Mylar 0.027 $\mu$ F(J) 50WV	2
		<b>Resistor, Stopper Type</b>	
15-R701	ER212264	Carbon RD1/4 22k(J)	2
15-R702	ER429996	Carbon RD1/4 470k(J)	2
15-R703, 4	ER336442	Carbon RD1/4 10k(J)	4
15-R705	ER357456	Carbon RD1/4 2.2k(J)	2
15-R706	ER306360	Carbon RD1/4 6.8k(J)	2

FIG. 16 PHOTO OF  
VOLUME P.C. BOARD (KD-A5014)

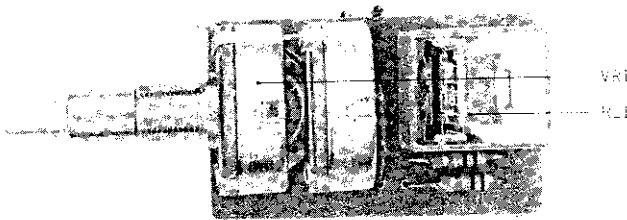

VOLUME P.C. BOARD (KD-A5014) BLOCK

Symbol No.	Parts No.	Description	Q'ty
16-1x	BA465873	Volume P.C. Board Comp. (KD-A5014)	1
16-2x	BA426328	Volume P.C. Board Comp. (KD-A5009) (Deck)	1
16-VR1	EV426791	Double Volume DJ20R 10 kAx2 (Frictional)	1
16-RL1	EP383321	Relay TECK-36 DC22V1000	1
		Resistor, Insulator Type	
16-R1, 2	ER345712	Carbon RD1/4 22k(J)	2
16-R3, 4	ER213647	Carbon RD1/4 10k(J)	2

FIG. 18 PHOTO OF POWER SUPPLY  
P.C. BOARD (KD-A5020)

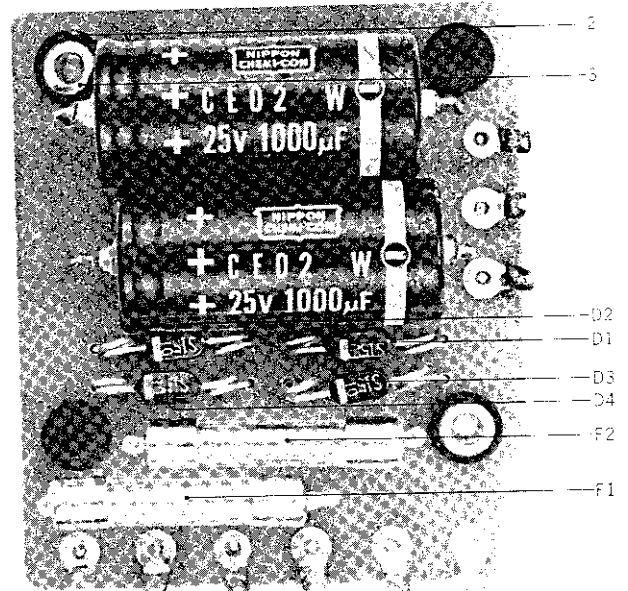
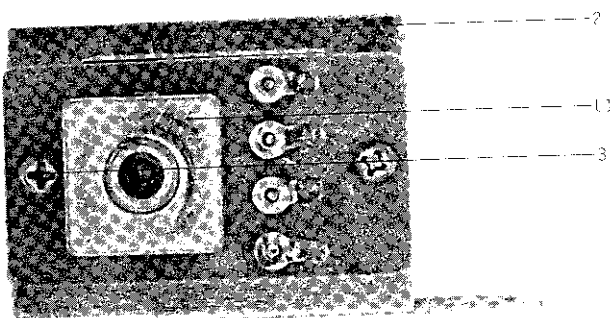

FIG. 17 PHOTO OF  
COIL P.C. BOARD (KD-1097)



COIL P.C. BOARD (KD-1097) BLOCK

Symbol No.	Parts No.	Description	Q'ty
17-1x	BA497845	Coil P.C. Board Comp. (KD-1097)	1
17-L1	BO403446	Variable Coil VI2031 SC-01	1
17-2	EZ495832	Coil P.C. Board Base	1
17-3	ZW413155	Screw, binding head 3x6	2

POWER SUPPLY P.C. BOARD (KD-A5020)  
BLOCK

Symbol No.	Parts No.	Description	Q'ty
18-1x	BA465963	Power Supply P.C. Board Comp. (KD-A5020)	1
18-D1 to 4	ED423742	Silicon Diode S-1.5-01	4
18-F1, 2	EF389597	Fuse ST-1 1.5A	2
18-2	EZ246611	P.C. Board Cushion	4
18-3	EZ237148	Eyelet D4x7x10	2
18-C1, 2	EC345791	Elect. Capacitor 1000 $\mu$ F 25WV (Tub. type)	2

When ordering parts, please describe Parts Number, Serial Number, and Model Number in detail.

FIG. 19 (A) ILLUSTRATION OF POWER SUPPLY BLOCK

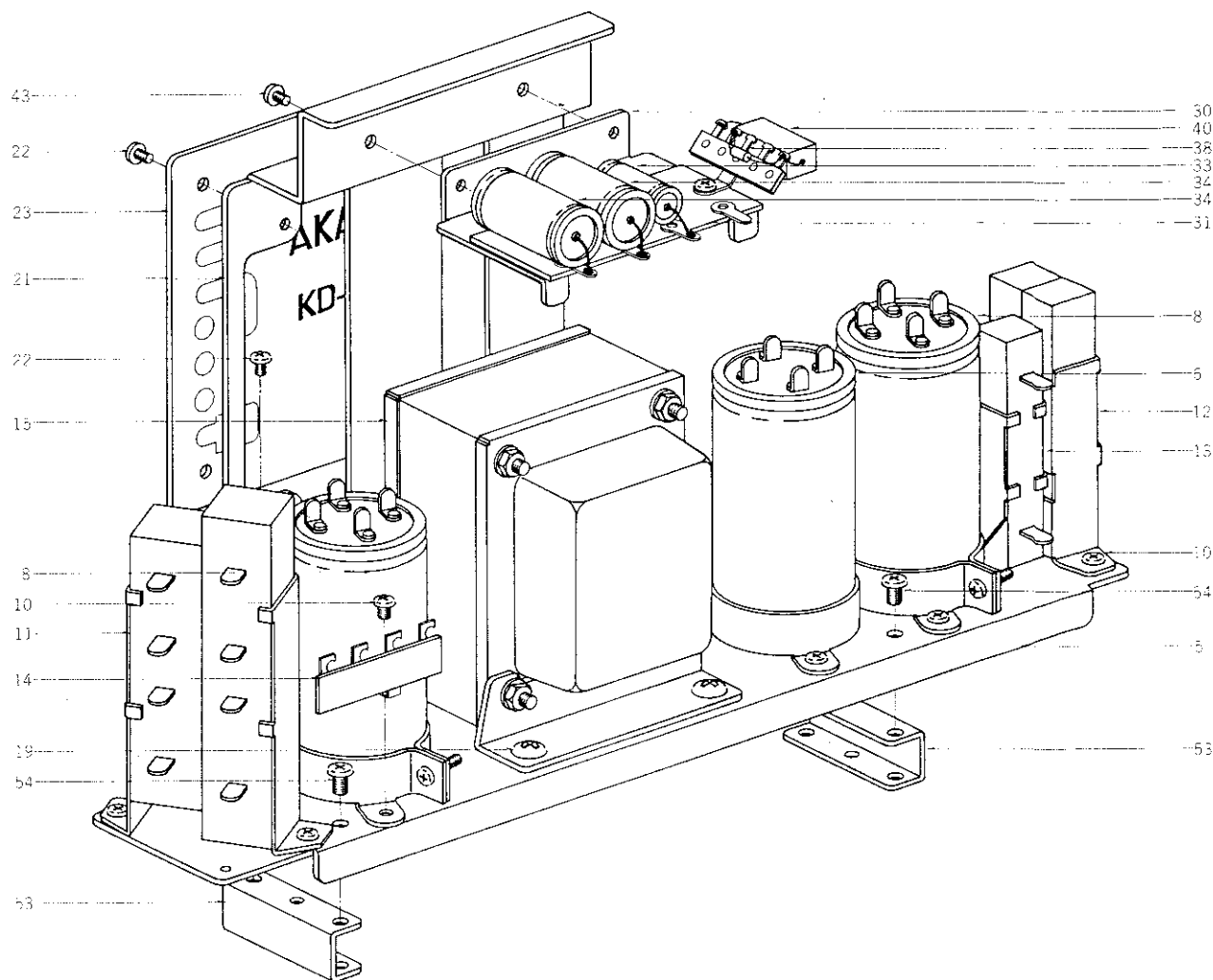
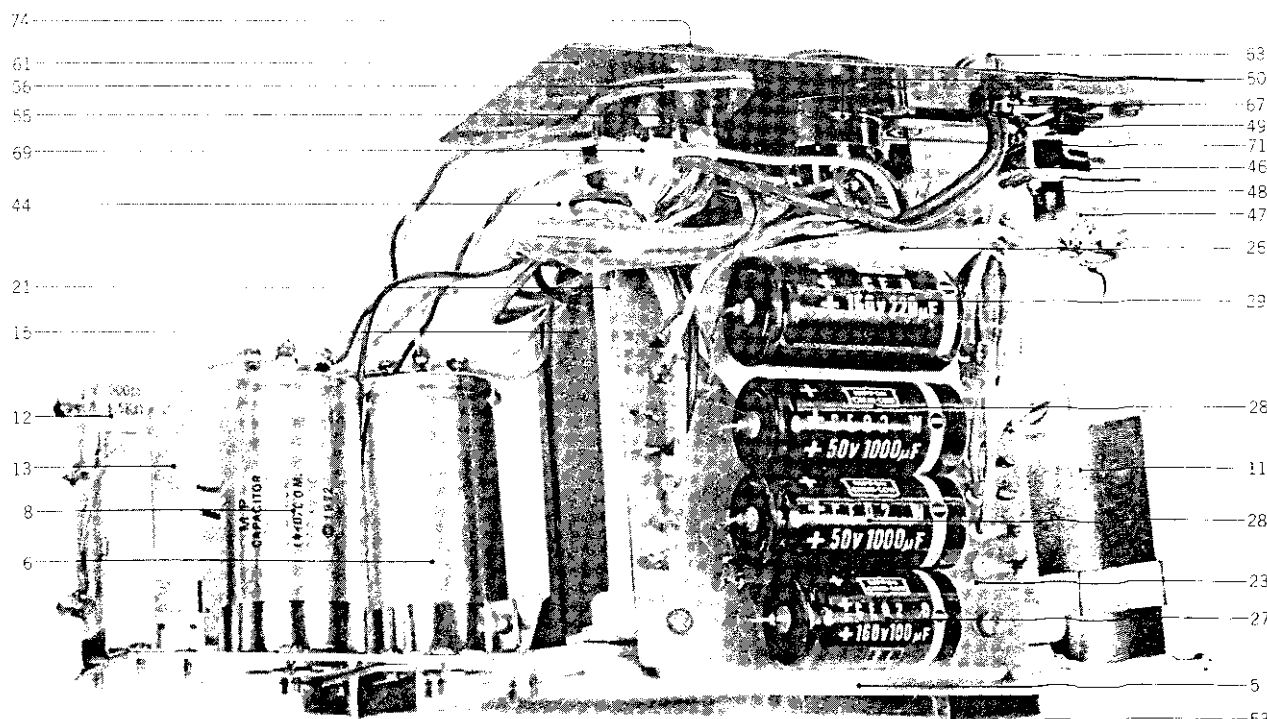

FIG. 19 (B) PHOTO OF POWER SUPPLY BLOCK



## POWER SUPPLY BLOCK

Ref. No.	Parts No.	Description	Schematic No.	Q'ty	Ref. No.	Parts No.	Description	Schematic No.	Q'ty
19-1x	BP465941	Power Supply Block Comp.		1	<b>MECH./AMP. ASSEMBLY BLOCK</b>				
19-2x	BA426251	Power Supply Block Comp. (Deck)		1	19-53	MZ397170	Trans. Table C	KD-1065	2
19-3x	BP515417	Power Supply Block Comp. (D-CSA)		1	19-54	ZW417150	Screw, pan head 4x6		4
19-4x	BP515428	Power Supply Block Comp. (D-UL)		1	19-55	EJ222748	Sub Magnale Socket #311SG	31-1-39	1
19-5	UM488924	Trans. Table	KH-2052	1	19-56	MZ302400	Remote Control Socket		
19-6	EC434081	MP/C. 3+0.5μF 200WV (Lug type Uni/D.)	24-9-58	1			Mt. Plate	RX-515	1
19-7x	EC515496	MP/C. 3μF 260WV (Lug type Uni/D.) (CSA,UL)	24-9-70	2	19-57x	EJ515193	Fuse Terminal Plate (CSA)	101061	1
19-8	EC398632	MP/C. 3+1μF 260WV (Lug type Uni/D.)	24-9-52	2	19-58x	EF497755	Fuse 1.6A 125V (CSA)	39-1-44	1
19-9x	EC515496	MP/C. 3μF 260WV (Lug type Uni/D.) (CSA,UL)	24-9-70	1	19-59x	EF497395	Fuse 2A 125V (CSA)	39-1-44	3
19-10	ZW472274	Tapping Screw #2 3x6		12	19-60x	ZW201150	Screw, truss head 3x6(black) (CSA)		6
19-11	ER426690	Cement/R. H(40+30)H2B (350+150x200+500)	35-16-25	1	19-61	EZ397293	Connector Plate	KD-2042	1
19-12	ER441955	Cement/R. H1B (60x1.5K+500)K	35-16-24	1	19-62x	EZ515485	Connector Plate (CSA,UL)	KD-A2015	1
19-13	ER472296	Cement/R. H20B 220(K)	35-16-16	1	19-63	EZ383938	U/L AC Cord 3M	26-3-20	1
19-14	EJ255003	Lug Plate KP1L2	33-3-5	1	19-64x	EZ486797	Power Supply Cord (VDE)	26-3-26	1
19-15	BT466288	Power Trans. KGT-1	38-4-144	1	19-65x	EZ516464	AC Cord 2.5M (CSA)	26-3-29	1
19-16x	BT466560	Power Trans. KGT-2 (D)	38-4-146	1	19-66x	EZ315448	Australia Cord (3 core)	26-3-11	1
19-17x	BT515215	Power Trans. KGT-3 (CSA)	38-4-204	1	19-67	EZ382263	Strain Relief SR-4K-4	2-7-12	1
19-18x	BT515226	Power Trans. KGT-5 (UL)	38-1-185	1	19-68x	EZ246936	Strain Relief SR-6W-1 (3 core)	2-7-8	1
19-19	ZW468112	Tapping Screw #2 4x8(truss)		4	19-69	EJ205986	Cramp Terminal 2-SD	32-1-8	3
19-20x	EZ461125	Trans. Shield Plate C (D)	MC-5017	1	19-70x	EJ205975	Cramp Terminal 1-SD (VDE,UL)	32-1-7	1
19-21	MZ465772	Trans. Table D	KD-A2008	1	19-71	EZ397124	Cycle Change Switch Plate B	KD-1055	1
19-22	ZW490228	Tapping Screw #2 3x8(bind)		6	19-72x	ZW374128	ISO Screw, truss head 3x8		2
19-23	EA465851	Capacitor P.C. Board	KD-A2013	1	19-73x	ZW447761	Tapping Screw #2 3x6(BR)		4
19-24x	EA515237	Capacitor P.C. Board B (UL)	KD-A2013	1	19-74	EJ326430	11P Short Plug A	42-1-25	1
19-25x	ED224550	Silicon Diode 10D4	45-2-16	1	19-75x	MZ396393	Lock Wire Tie 11M/M		1
19-26	EZ472206	Capacitor Insulator Plate B	KD-2064	1	19-76x	EZ495832	Coil P.C. Board Base (UL)	KD-1098	1
19-27	EC316091	Elect. 100μF 160WV (Tub. type)	24-14-14	1	19-77x	EA515204	Fuse P.C. Board KD(UL)	KD-A2020	1
19-28	EC365692	Elect. 1000μF 50WV (Tub. type)	24-13-15	2	19-78x	EF338387	Fuse ST-2 1.5A (UL)	39-1-26	1
19-29	EC346746	Elect. 220μF 160WV (Tub. type)	24-14-8	1	19-79x	EJ514822	Fuse Holder P.C. Board (UL)	40-1-28	2
19-30	EZ397282	Capacitor Retaining Base	KD-2027	1	19-80x	ZW413155	Screw, binding head 3x6 (UL)		4
19-31	EZ398946	Terminal Plate SP-0501 4P(B type)	33-2-17	1	19-81x	MB229138	Wire Bundle Holder (CSA)	2-35-1	1
19-32x	ER430143	Carbon/R. RD1/4 120(J) (Insu. type)	35-9-5	1					
19-33	EC273464	MP/C. 0.1μF(M) 350WVDC (Tub. type)	24-9-4	1					
19-34	EC341842	MP/C. 0.47μF(M) 300WVAC (Tub. type)	24-9-35	2					
19-35x	ZW273778	Earth Lug M3 (3 core)		1					
19-36x	ER376424	Spark Quencher U/L 0.1μ+120 500WV (CSA)	41-1-36	1					
19-37	EJ255115	Lug Plate VB2L2	33-4-3	1					
19-38	ED224550	Silicon Diode 10D4	45-2-16	1					
19-39x	ZW323728	Screw, binding head 3x5		2					
19-40	ER466986	Cement/R. S5W 45(K) (Wire-wound type)	35-16-3	1					
19-41x	MZ515261	Capacitor Mt. Angle (UL)	KD-A2017	1					
19-42x	ER450786	Spark Quencher U/L 0.1μ+120 400WV (UL)	41-1-33	1					
19-43	ZW323728	Screw, binding head 3x5		2					
19-44	EZ328320	Nylon Clip HP-5N		2					
19-45x	ZW462194	Tapping Screw #2 3x8(pan), w/washer		2					
19-46	EZ397304	Frequency Change Switch Plate A	KD-2043	1					
19-47	ES375478	Slide Switch ESD-279DU	25-3-23	2					
19-48	ZW371856	ISO Screw, binding head 3x5		2					
19-49	ZW440291	ISO Screw, countersunk head 3x6		2					
19-50	EJ233370	Power Plug Socket S-18010 (Volt/S.)	40-2-3	1					
19-51x	EF277413	Fuse ST-2 2A	39-1-26	1					
19-52x	EF338387	Fuse ST-2 1.5A (D)	39-1-26	1					

When ordering parts, please describe Parts Number, Serial Number, and Model Number in detail.

FIG. 20 PHOTO OF SUB PANEL (LEFT) BLOCK

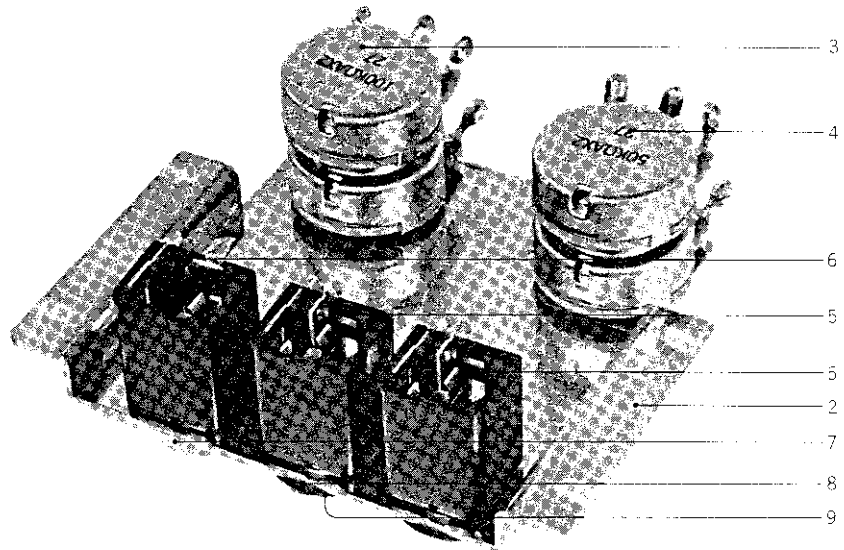

SUB PANEL (LEFT) BLOCK

Ref. No.	Parts No.	Description	Schematic No.	Q'ty
20-1x	BZ398485	Sub Panel (Left) Block Comp.	KG-1	1
20-2	SP397991	Sub Panel (left)	KD-5019	1
20-3	EV398586	Double Volume DJ20A 100kx2(Frictional)	36-3-26	1
20-4	EV398575	Double Volume DJ20A 50kx2(Frictional)	36-3-25	1
20-5	EJ291094	Mic. Jack 2PMJ1P	31-2-27	2
20-6	EJ391083	Mic. Jack 3PMJ1P	31-2-28	1
20-7	EZ225180	Nylon Collar, Jack	L.D-520	2
20-8	ZW260368	Washer (Fiber)D9.2x18x0.5t		2
20-9	ZW375153	E Jack Nut		3
20-10x	ZW272722	Toothed Lock Washer M9 D9.3x13x0.5t		1
20-11x	ZW406181	Washer (Mylar) D9.2x18x0.25t		2



FIG. 21 PHOTO OF AMP. ASSEMBLY BLOCK

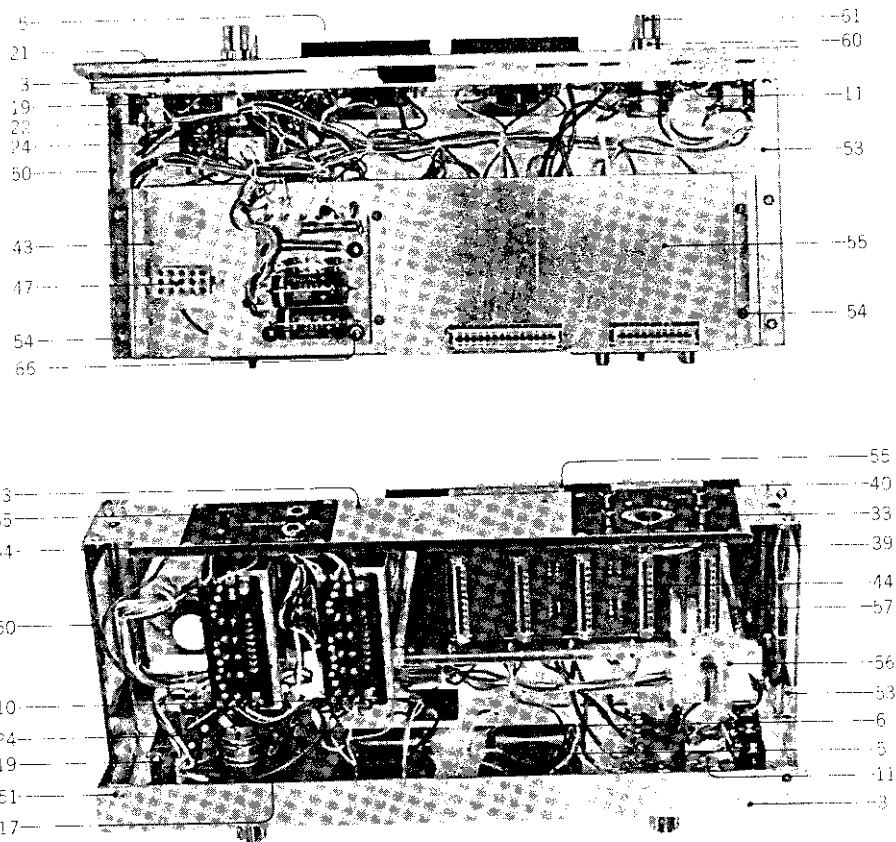

## AMP. ASSEMBLY BLOCK

Ref. No.	Parts No.	Description	Schematic No.	Q'ty	Ref. No.	Parts No.	Description	Schematic No.	Q'ty
<b>AMP. PANEL BLOCK</b>									
21-1x	BZ465928	Amp. Panel Block Comp.	KD	1	21-51	ZW424124	Screw, countersunk head 3x5		2
21-2x	BZ426306	Amp. Panel Block Comp. (Deck)	KD	1	21-52x	ZW323728	Screw, binding head 3x5		2
21-3	SP466233	Amp. Panel C	KD-A5012	1	21-53	SP398722	Side Panel B (Left)	KD-5005	1
21-4x	SP426947	Amp. Panel (Deck)	KD-A5005	1	21-54	ZW447772	Tapping Screw #2 3x6(BR)		18
21-5	EM433923	VU Meter VH-10EB	46-1-44	2	21-55	EZ397822	Amp. Shield	KD-5011	1
21-6	ZG290878	VU Meter Spring	DX-504	8	21-56	EZ397877	OSC Shield	KD-5009	1
21-7x	ZW273756	Nut M3		8	21-57	EZ397833	P.C. Board Post	KD-5007	2
21-8x	EZ397890	Rec. Button Escutcheon (Deck)	KD-5003	1	21-58x	ZW417025	Screw, binding head 3x8, w/washer		4
21-9x	EZ426780	Illumination Escutcheon (red)	61-5023	1	21-59x	EZ397811	Card Retainer	KD-5010	1
21-10	WM409331	Lamp Mask	61-5033	1	21-60	SK397912	Double Knob A Comp.	KD-5012	4
21-11	BZ398485	Sub Panel (Left) Block Comp.	KG-1	1	21-61	SK428905	Double Knob B2 Comp.	KD-5013	4
21-12x	ZW323728	Screw, binding head 3x5		8	21-62x	ZW200766	Set Screw, 3x5(cup)		4
21-13x	BZ465862	Sub Panel (Right) Block Comp.	KGA	1	21-63x	ZW200755	Set Screw, 3x5.5(cup)		4
21-14x	BZ426317	Sub Panel (Right) Block Comp. (Deck)	KGD	1	21-64	EJ466661	Speaker Jack Plate, w/jack	31-5-53	1
					21-65	ES317531	Slide Switch ESD-271DU	25-3-24	1
					21-66	ZW462802	Tapping Screw #2 3x15(BR)		2
<b>SUB PANEL (RIGHT) BLOCK</b>									
21-15x	BZ465862	Sub Panel (Right) Block Comp.	KGA	1					
21-16x	BZ426317	Sub Panel (Right) Block Comp. (Deck)	KGD	1					
21-17	SP397945	Sub Panel (Right)	KD-5014	1					
21-18x	BZ466165	Sub Panel (R) Reinforcement Plate	KD-A5016	1					
21-19	ES374051	Push Switch UEG-22CP	25-5-26	2					
21-20x	ZW366074	Screw, round head 2.6x4		2					
21-21	SK371621	PTA Knob (black)	ED-615	2					
21-22	BA465873	Volume P.C. Board Comp. (KD-A5014)	KGA	1					
21-23x	BA426328	Volume P.C. Board Comp. (KD-A5009) (Deck)	KGD	1					
21-24	BA466277	Tone Control P.C. Board Comp. (MS-5028)	KGA	1					
21-25x	EZ397956	Rec. Button Bracket (D)	KD-5015	1					
21-26x	ES250075	Micro Switch V-1A10 U/L (D)	25-1-8	1					
21-27x	ZW422965	Screw, pan head 3x15 (D)		2					
21-28x	ZG396628	Rec. Button Spring (D)	KD-5018	1					
21-29x	SB397967	Rec. Button, w/rod (D)	KD-5016	1					
21-30x	ZW270101	'E' Ring 3M (D)	6-1-9	1					
21-31x	ZW323728	Screw, binding head 3x5 (D)		2					
<b>JACK PLATE BLOCK</b>									
21-32x	BZ398507	Jack Plate Block Comp.	KG-1, KA	1					
21-33	EJ331356	RDG Line Jack Plate	31-5-21	1					
21-34x	ER430288	Carbon/R. RD1/4 680(J) (Insu. type)	35-9-5	2					
21-35x	ER214536	Carbon/R. RD1/4 6.8k(J) (Insu. type)	35-9-5	2					
21-36x	ER345756	Carbon/R. RD1/4 68k(J) (Insu. type)	35-9-5	2					
21-37x	ER345712	Carbon/R. RD1/4 22k(J) (Insu. type)	35-9-5	2					
21-38x	ER213647	Carbon/R. RD1/4 10k(J) (Insu. type)	35-9-5	2					
21-39	EJ299305	5P Din-jack	31-1-1	1					
21-40	ES452057	6P Slide Switch S-J0282 #01	25-3-36	1					
21-41x	ZW410231	Screw, pan head 2.6x5		2					
21-42x	ZW273778	Earth Lug M3		1					
<b>AMP. ASSEMBLY BLOCK</b>									
21-43	EZ397855	Amp. Chassis	KD-5008	1					
21-44	BA398542	Pre Amp. Chassis P.C. Board Comp. (KD-5027)		1					
21-45x	ZW447805	Tapping Screw #2 3x12(BR)		4					
21-46x	ZW447840	Tapping Screw #2 3x8(BR)		10					
21-47	EJ340446	15P Mate-N-Lock Plug Housing 1-480323-0	52-1-6	1					
21-48x	EJ229353	Socket Contact 60510-1	52-1-1	23					
21-49x	EJ330508	9P Mate-N-Lock Plug Housing 1-480274-0 (D)	52-1-7	1					
21-50	SP397844	Side Panel A (Right)	KD-5005	1					

When ordering parts, please describe Parts Number, Serial Number, and Model Number in detail.

FIG. 22 PHOTO OF FINAL ASSEMBLY BLOCK

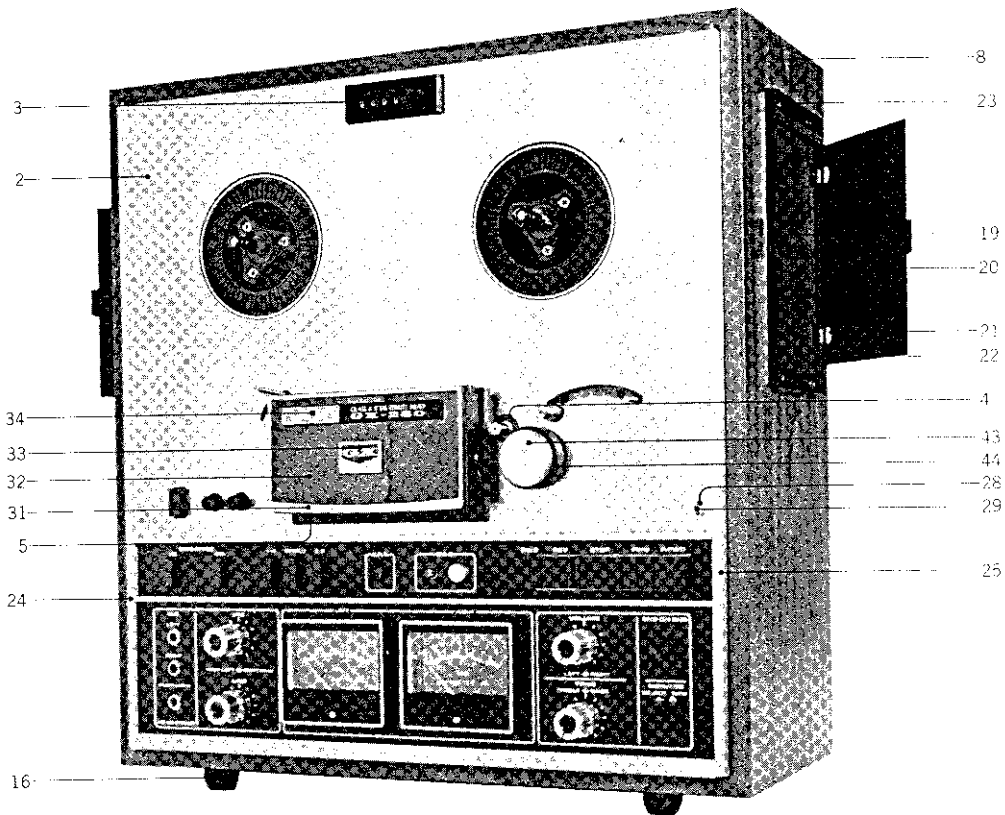

FINAL ASSEMBLY BLOCK

Ref. No.	Parts No.	Description	Schematic No.	Q'ty	Ref. No.	Parts No.	Description	Schematic No.	Q'ty
<b>MECH. PANEL BLOCK</b>					<b>ASSEMBLY BLOCK</b>				
22-1x	SP435025	Mech. Panel Block Comp.	KG-1	1	22-24	SZ435014	Sash (Left), w/pin	KD-6005	1
22-2	SP435071	Mech. Panel B, w/ring	KD-6006	1	22-25	SP406067	KD Sash (Right), w/pin	KD-6005	1
22-3	SZ397618	Counter Escutcheon	KD-6008	1	22-26x	ZW447805	Tapping Screw #2 3x12(BR)		2
22-4	SZ397620	Capstan Escutcheon	KD-6009	1	22-27x	ZW200384	Screw, countersunk head 3x6		2
22-5	ZW397631	Head Cover Base Washer	KD-6010	1	22-28	ZW408418	Panel Washer	KD-6029	2
22-6x	ZW413155	Screw, binding head 3x6		2	22-29	ZW203084	Screw, oval countersunk head 3x8		2
22-7x	ZW200766	Set Screw, 3x5(cup)		2	22-30x	ZW323728	Screw, binding head 3x5		2
<b>CASE BLOCK</b>					22-31	SC426407	Head Cover	KD-A6001	1
22-8x	BC465906	Case Block Comp.	KGA	1	22-32	SZ426418	Head Cover Plate	KD-A6002	1
22-9x	BC398294	Case Block Comp. (Deck)	KGD, KA	1	22-33	SZ382285	GX Symbol Plate	RD-A633	1
22-10x	ZW447963	Tapping Screw #1 3x10(truss)		23	22-34	SM466110	Name Plate GX-280	KD-A6009	1
22-11x	SZ439694	Case Corner Angle	KD-6031	2	22-35x	SZ426420	Name Plate GX-280D	KD-A6003	1
22-12x	SZ382230	Ventilator (Upper)	RD-A404	1	22-36x	ZW201150	Screw, truss head 3x6(black)		2
22-13x	ZW273756	Nut M3		4	22-37x	ZW259806	Washer (SPC-1)D4.5x12.8x1t		6
22-14x	SZ382241	Ventilator Retaining Plate	RD-A405	1	22-38x	ZW366377	Tapping Screw #1 4x45(truss)		4
22-15x	ZW439672	Tapping Screw #1 4x10(truss)		1	22-39x	SZ377190	LM Rubber Foot	LM-404	4
22-16	SZ377190	LM Rubber Foot	LM-404	4	22-40x	ZW419646	Washer (SPC)D4.5x9.8x0.5t		4
22-17x	ZW419646	Washer (SPC)D4.5x9.8x0.5t		4	22-41x	ZW434283	Tapping Screw #1 4x30(truss)		4
22-18x	ZW403571	Wood Screw, round head 4.5x20		4	22-42x	ZW200621	Tapping Screw #1 4x25(truss)		2
22-19	SZ424945	Speaker Grill	MS-6004	2	22-43	SK425158	Pinch Roller Cap, w/screw	MS-6020	1
22-20	SZ424967	Reflection Plate, w/shaft	MS-6006	2	22-44	MP424023	Pinch Roller (KD)	KD-1084	1
22-21	SZ237508	Reflection Plate Retaining Metal	3A-419	4	22-45x	SZ466121	Ventilator Panel B	KD-6015	1
22-22	ZW201183	Screw, truss head 3x8(black)		4	22-46x	SZ397563	Ventilator Panel (VDE)	KD-6015	1
22-23	ZW324448	Tapping Screw #1 3x10(truss)		8	22-47x	SZ515351	Ventilator Panel C (CSA,UL)	KD-6015	1
					22-48x	ZW324448	Tapping Screw #1 3x10(truss) (black)		4
					22-49x	EF277413	Fuse ST-2 2A	39-1-26	1
					22-50x	EF338387	Fuse ST-2 1.5A	39-1-26	1
					22-51x	EF304626	Fuse ST-4 1A	39-1-28	1
					22-52x	EF444183	Fuse 1.5A 250V	39-1-41	1

When ordering parts, please describe Parts Number, Serial Number, and Model Number in detail.

# INDEX

Parts No.	Ref. No. & Symbol No.	Parts No.	Ref. No. & Symbol No.	Parts No.	Ref. No. & Symbol No.	Parts No.	Ref. No. & Symbol No.	Parts No.	Ref. No. & Symbol No.
BA398542	14-1x	EC220994	8-C116	EC520492	11-C301	ER211465	9R224, 5	ER345712	21-37x
BA398542	21-44	EC220994	10-C105,6,7	ED219464	10-D104	ER211465	10-R101	ER345756	21-36x
BA423876	9-1x	EC220994	10-C110	ED219464	10-D106,7,8	ER211465	10-R108	ER346601	13-R302,3
BA426251	19-2x	EC220994	12-C1	ED219464	10-D111to15	ER211465	10-R126,7	ER346994	7-R206
BA426273	4-21x	EC220994	12-C7,8	ED219464	10-D120to22	ER211465	10-R130	ER349784	7-R227
BA426273	13-2x	EC220994	15-C702	ED219464	10-D124,5	ER211465	10-R132	ER349942	7-R213
BA426284	10-1x	EC250661	9-C206	ED224526	9-D204	ER211667	9-R220	ER352045	7-R225
BA426328	16-2x	EC250683	15-C704	ED224526	9-D201,2	ER211667	10-R124	ER357456	7-R208
BA426328	21-23x	EC250841	8-C109	ED224526	10-D101,2,3	ER211757	7-R215	ER357456	9-R203
BA426330	7-1x	EC250841	11-C303,4	ED224526	10-D110	ER211757	9-R209	ER357456	9-R210
BA426341	8-1x	EC250918	9-C256	ED224526	10-D116to19	ER211858	7-R224	ER357456	9-R219
BA426352	11-1x	EC250975	13-C302	ED224526	10-D126	ER211858	8-R109	ER357456	9-R222,3
BA465873	16-1x	EC250975	13-C305	ED224550	10-D123	ER212016	9-R211	ER357456	9-R251
BA465873	21-22	EC251190	9-C202	ED224550	10-D127	ER212264	7-R209	ER357456	9-R254
BA465952	12-1x	EC273464	5-105	ED224550	19-25x	ER212264	7-R221	ER357456	10-R110
BA465963	18-1x	EC273464	10-C108	ED224550	19-38	ER212264	8-R105	ER357456	10-R113
BA466277	15-1x	EC273464	19-33	ED321390	9-TH201	ER212264	8-R111	ER357456	10-R116
BA466277	21-24	EC290520	8-C104	ED329128	9-D252	ER212264	9-R204	ER357456	10-R119
BA467256	4-20	EC290564	8-C110	ED329130	9-D251	ER212264	15-R701	ER357456	15-R705
BA467256	13-1x	EC290564	12-C2	ED423742	18-D1 to 4	ER212477	8-R106	ER357570	7-R205
BA497845	17-1x	EC308711	10-C104	ED520762	9-D253	ER212681	7-R223	ER357570	8-R107
BA515441	9-2x	EC316091	19-27	EF277413	19-51x	ER212681	8-R104	ER361528	7-R220
BA515452	9-3x	EC320051	7-C205	EF277413	22-49x	ER212681	9-R211	ER361642	9-R208
BC371428	12-2	EC320051	7-C209	EF304626	22-51x	ER212681	9-R252	ER362441	7-R217
BC398294	22-9x	EC320051	7-C218	EF338387	19-52x	ER212883	7-R210	ER362441	9-R202
BC465906	22-8x	EC320051	8-C105	EF338387	19-78x	ER212883	7-R216	ER362441	13-R305,6
BH426240	1-1x	EC320051	8-C111	EF338387	22-50x	ER212883	7-R222	ER362485	7-R202
BM314741	2-1	EC320051	9-C205	EF389597	18-F1, 2	ER212883	8-R108	ER362485	8-R101,2
BM423854	3-1x	EC320051	15-C701	EF444183	22-52x	ER212883	8-R112	ER362485	10-R102
BP465941	19-1x	EC329771	7-C203	EF497395	19-59x	ER212883	9-R214	ER362485	10-R106
BP515417	19-3x	EC329771	7-C206	EF497755	19-58x	ER212883	9-R218	ER363644	12-R1
BP515428	19-4x	EC329771	7-C211	EF515305	9-FR1	ER212883	10-R104,5	ER376424	5-3x
BR398430	2-2x	EC329771	7-C214	EF515316	9-FR2	ER212883	10-R107	ER376424	5-21x
BR398441	2-3x	EC329771	8-C103	EF515327	9-FR3	ER212883	10-R109	ER376424	10-CR101,2
BS423865	5-55x	EC329771	8-C106	EI412413	8-IC101	ER212883	10-R112	ER376424	19-36x
BS515430	5-56x	EC329771	8-C113	EI466075	12-3	ER212883	10-R115	ER376435	5-31x
BT247746	8-T101	EC329850	8-C114	EJ205975	19-70x	ER212883	10-R128	ER380147	10-R133
BT466288	19-15	EC329850	9-C209	EJ205986	19-69	ER212883	11-R302	ER380711	8-R110
BT466560	19-16x	EC329861	15-C706	EJ222748	6-12	ER213030	9-R221	ER391623	10-R118
BT515215	19-17x	EC331705	9-C203	EJ222748	19-55	ER213030	10-R129	ER391623	10-R121
BT515226	19-18x	EC331817	9-C254	EJ229353	21-48x	ER213300	7-R218	ER398856	11-R301
BZ398338	5-19x	EC334620	12-C9	EJ233370	19-50	ER213300	10-R120	ER403097	9-R213
BZ398340	5-27x	EC337487	7-C220	EJ255003	19-14	ER213300	10-R123	ER403187	9-R212
BZ398362	5-46x	EC337487	7-C222	EJ255115	19-37	ER213647	16-R3, 4	ER424078	9-R228
BZ398485	20-1x	EC341842	19-34	EJ292926	14-J5	ER213647	21-38x	ER426690	19-11
BZ398485	21-11	EC345791	18-C1,2	EJ293084	14-J7	ER213715	14-R402	ER426892	11-R306
BZ398507	21-32x	EC346746	19-29	EJ299305	21-39	ER213715	14-R406	ER429996	15-R702
BZ426262	4-2x	EC350684	9-C208	EJ300508	21-49x	ER214536	21-35x	ER430143	19-32x
BZ426306	21-2x	EC350684	9-C255	EJ310871	6-8x	ER304290	9-R226	ER430288	21-34x
BZ426317	21-14x	EC365692	19-28	EJ326430	6-28	ER304290	10-R134	ER441955	19-12
BZ426317	21-16x	EC368335	15-C703	EJ326430	19-74	ER304402	7-R204	ER450011	7-R212
BZ428940	5-1x	EC368370	7-C213	EJ331356	21-33	ER304402	11-R303	ER450786	19-42x
BZ434992	5-68x	EC372148	9-C253	EJ331380	5-154x	ER306360	7-R207	ER466986	19-40
BZ435003	1-9x	EC379170	7-C216	EJ340446	21-47	ER306360	13-R301	ER467054	6-9
BZ465862	21-13x	EC379192	13-C301	EJ345284	6-9	ER306360	13-R304	ER472296	19-13
BZ465862	21-15x	EC379192	13-C304	EJ364915	1-72x	ER306360	15-R706	ER473547	9-R256
BZ465928	21-1x	EC379765	7-C224	EJ391083	20-6	ER306843	9-R255	ER539065	10-R122
BZ465930	4-1x	EC379787	9-C204	EJ391094	20-5	ER306887	9-R217	ES246025	5-32
BZ466165	21-18x	EC383501	7-C202	EJ398733	14-2	ER306887	9-R227	ES246025	6-1
EA222096	13-3	EC398632	19-8	EJ450573	6-11x	ER315944	11-R304,5	ES250064	5-8
EA382713	13-4	EC398957	9-C201	EJ466661	21-64	ER329308	14-R401	ES250064	5-102
EA396898	4-11	EC399690	7-C204	EJ514822	19-79x	ER329308	14-R403,4,5	ES250075	4-18
EA463206	1-39x	EC403468	9-C251,2	EJ515193	19-57x	ER329308	14-R407,8	ES250075	5-9
EA465851	19-23	EC407114	7-C210	EL390576	4-12	ER332212	12-R2	ES250075	5-39
EA466547	1-40x	EC407272	7-C207	EM433923	21-5	ER336442	7-R201	ES250075	6-1
EA515204	19-77x	EC411827	13-C303	EO243977	13-L301,2	ER336442	7-R203	ES250075	2126x
EA515237	19-24x	EC411827	13-C306	EO244001	8-L101	ER336442	7-R211	ES317531	5-2
EC220151	9-C207	EC424080	9-C210	EO321254	7-L201	ER336442	8-R103	ES317531	2165
EC220151	12-C4	EC425250	11-TC301,2	EO346500	13-L305	ER336442	9-R201	ES374051	4-7
EC220364	8-C115	EC432810	7-C201	EO383365	11-L301	ER336442	9-R205,6,7	ES374051	13SW19
EC220432	9-C213	EC432810	8-C101	EO403446	17-L1	ER336442	10-R103	ES374051	2119
EC220612	10-C103	EC434081	19-6	EO458932	13-L303,4	ER336442	10-R125	ES375478	1947
EC220612	10-C109	EC438041	15-C705	EP344136	10-RL101to6	ER336442	10-R131	ES424146	13SW301
EC220678	7-C217	EC438524	9-C211	EP383321	11-RL301	ER336442	15-R703,4	ES448053	13SW302
EC220678	8-C112	EC456041	10-C101,2	EP383321	16-RL1	ER342933	7-R219	ES452057	2140
EC220678	11-C302	EC476965	7-C208	EP398610	5-20	ER343078	9-R253	ES479395	5-33x
EC220678	12-C3	EC476965	8-C107	EP441990	5-2	ER343078	10-R111	ES479395	6-1x
EC220678	12-CS, 6	EC515496	19-7x	EP804813	1-58	ER343078	10-R114	ET234843	7-R203
EC220994	7-C215	EC515496	19-9x	ER211465	7-R214	ER343078	10-R117	ET304255	11TR301,2
EC220994	7-C221	EC517116	9-C215	ER211465	7-R226	ER345712	16-R1,2	ET338894	7-R205

# INDEX

Parts No.	Ref. No. & Symbol No.	Parts No.	Ref. No. & Symbol No.	Parts No.	Ref. No. & Symbol No.	Parts No.	Ref. No. & Symbol No.	Parts No.	Ref. No. & Symbol No.
ET338894	10-TR109to11	HE412187	1-29	MV408510	3-4	SK371621	4-29	ZW201475	3-17
ET356984	9-TR202	HK398452	3-15	MZ250413	5-101	SK371621	13-8	ZW201835	5-23x
ET356984	9-TR205	HL426510	1-80	MZ302400	6-13	SK371621	21-21	ZW202252	1-18
ET379462	7-TR204	HL426521	1-83	MZ302400	19-56	SK397590	5-44	ZW203084	22-29
ET379462	9-TR201	HL426565	1-85	MZ314998	2-23	SK397912	21-60	ZW206021	3-6
ET379462	9-TR203,4	HL809998	1-66	MZ314998	5-118	SK425158	22-43	ZW231805	5-73
ET379462	9-TR207	HP384524	1-42	MZ315000	2-24	SK428905	21-61	ZW243516	5-126
ET391138	9-TR253	HR384513	1-34	MZ315000	5-119	SM466110	22-34	ZW257477	1-67
ET393581	9-TR251	HZ231884	1-75	MZ317373	2-31	SP397844	21-50	ZW257477	5-10
ET398711	10-TR101to8	HZ243191	6-10x	MZ317373	5-89	SP397945	21-17	ZW257477	5-25
ET398711	15-TR701	HZ317632	1-13	MZ317406	2-30	SP397991	20-2	ZW259648	1-52
ET398777	9-TR206	HZ317698	1-59	MZ317406	5-155	SP398722	21-53	ZW259683	5-146x
ET398845	7-TR201,2	HZ320940	1-65	MZ373318	1-73x	SP406067	22-25	ZW259806	22-37x
ET398845	8-TR101,2	HZ321344	1-60	MZ396393	19-75x	SP426947	21-4x	ZW260201	1-78
ET399936	9-TR208	HZ321366	1-62	MZ396527	5-51	SP435025	22-1x	ZW260368	20-8
ET403042	9-TR209	HZ321377	1-63	MZ396551	5-47	SP435071	22-2	ZW270088	1-68
ET403042	9-TR252	HZ321434	1-77	MZ396573	5-48	SP466233	21-3	ZW270088	2-9
EV221826	10-VR102	HZ382656	1-41	MZ396617	4-10x	SS466143	6-34	ZW270088	5-12x
EV221850	8-VR101	HZ382667	1-43	MZ396674	4-4	SZ237508	22-21	ZW270088	5-26x
EV398575	20-4	HZ382680	1-28	MZ396707	4-3	SZ377190	22-16	ZW270088	5-66
EV398586	20-3	HZ382691	1-33	MZ396832	5-109	SZ377190	22-39x	ZW270088	5-143
EV398812	7-VR201	HZ396494	1-3	MZ396911	5-4	SZ382230	22-12x	ZW270088	5-147x
EV398834	9-VR251	HZ396505	1-16	MZ396911	5-22	SZ382241	22-14x	ZW270101	1-82
EV424743	15-VR701	HZ396584	1-10	MZ396922	5-6	SZ382285	22-33	ZW270101	4-9
EV426791	16-VR1	HZ396595	1-14	MZ396933	5-15	SZ397495	6-29	ZW270101	5-14x
EV426936	10-VR101	HZ396797	1-11	MZ396944	5-11	SZ397506	6-30	ZW270101	5-111x
EV484863	9-VR251	HZ397034	5-87	MZ396966	5-9	SZ397517	5-159x	ZW270101	21-30x
EV499364	9-VR202	HZ412637	1-6	MZ396977	5-24	SZ397528	5-160	ZW270123	5-37x
EZ225180	20-7	HZ426486	1-2	MZ396988	5-135x	SZ397530	5-161x	ZW272722	20-10x
EZ237148	18-3	HZ426497	1-46	MZ396990	5-79	SZ397541	5-162	ZW273734	5-35x
EZ246611	18-2	HZ426508	1-47	MZ396990	6-1	SZ397563	22-46x	ZW273745	6-37x
EZ246936	6-24x	HZ426543	1-81	MZ397045	5-96x	SZ397618	22-3	ZW273756	1-8
EZ246936	19-68x	HZ426554	1-84	MZ397078	5-100	SZ397620	22-4	ZW273756	6-38x
EZ315448	6-22x	HZ426666	1-24	MZ397080	5-97	SZ424945	22-19	ZW273756	9-7
EZ315448	19-66x	HZ433890	1-79	MZ397168	5-90	SZ424967	22-20	ZW273756	21-7x
EZ328320	19-44	HZ434272	1-21	MZ397170	19-53	SZ426418	22-32	ZW273756	22-13x
EZ380428	9-12	HZ803597	1-20	MZ397181	5-110	SZ426420	22-35x	ZW273778	1-15
EZ382263	6-23	HZ810011	1-56	MZ397192	5-53	SZ435014	22-24	ZW273778	1-32x
EZ382263	19-67	MB229138	6-33x	MZ397203	5-49	SZ439694	22-11x	ZW273778	2-13x
EZ383938	6-19	MB229138	19-81x	MZ397214	5-52	SZ466121	22-45x	ZW273778	4-22x
EZ383938	19-63	MB303535	2-21	MZ397315	5-138	SZ515351	22-47x	ZW273778	5-61x
EZ397124	6-25	MB303535	5-128	MZ397315	6-4	UM437848	5-150x	ZW273778	5-124x
EZ397124	19-71	MB314987	2-22	MZ397337	5-67	UM488924	19-5	ZW273778	9-18x
EZ397135	6-15	MB314987	5-117	MZ397337	5-140	WM409331	21-10	ZW273778	19-35x
EZ397282	19-30	MC399521	5-99	MZ397337	6-6	ZG206144	1-25	ZW273778	21-42x
EZ397293	6-17	ML314976	2-28	MZ397348	5-141	ZG208091	5-127	ZW273802	1-7x
EZ397293	19-61	ML314976	5-116	MZ397348	6-7	ZG246857	1-69	ZW273802	9-11x
EZ397304	19-46	ML396742	5-112	MZ397350	5-57	ZG256533	2-7	ZW273868	1-53
EZ397721	9-13	ML396810	2-29x	MZ397394	5-131	ZG290878	21-6	ZW273960	5-16
EZ397732	9-16	ML396810	5-122	MZ397405	5-28	ZG303300	1-54	ZW274026	5-81x
EZ397743	6-16	ML396900	5-148	MZ397416	5-32	ZG315011	2-27	ZW290248	6-31
EZ397743	9-14x	ML397383	5-63	MZ397462	5-34	ZG315011	5-121	ZW290250	6-32
EZ397811	21-59x	ML403503	5-65	MZ397484	5-40	ZG317114	5-78	ZW290283	1-86
EZ397822	21-55	ML409083	5-145	MZ398182	3-14	ZG317496	2-16	ZW290283	2-26
EZ397833	21-57	MP424023	5-156x	MZ400421	3-16	ZG321445	1-51	ZW290283	5-114
EZ397855	21-43	MP424023	22-44	MZ405377	5-59	ZG366761	5-151	ZW317171	5-74
EZ397866	14-3	MR317507	2-17	MZ405437	3-2	ZG382757	1-36	ZW321592	3-10
EZ397877	21-56	MS217192	5-92	MZ428343	1-22	ZG396516	5-50	ZW323728	1-31
EZ397890	21-8x	MS250165	5-142	MZ428343	5-8x	ZG396628	21-28x	ZW323728	1-61
EZ397956	21-25x	MS342000	2-6	MZ428343	5-93	ZG397440	5-36	ZW323728	2-25x
EZ397980	4-30x	MS397001	5-80	MZ432832	5-70	ZG407575	5-115	ZW323728	3-19
EZ397980	13-7	MS397012	5-82	MZ433721	5-152	ZG409015	5-149	ZW323728	4-13
EZ398946	19-31	MS397023	5-86	MZ434237	5-157	ZG428398	4-8	ZW323728	5-5x
EZ405213	9-8	MS397372	5-62	MZ434316	5-71	ZG428927	5-18	ZW323728	5-43
EZ407586	9-4	MS397451	5-33	MZ434970	5-72	ZG433383	5-94	ZW323728	5-98
EZ426723	4-26	MS397473	5-39	MZ434981	5-76	ZG465478	5-113	ZW323728	5-120
EZ426723	13-5	MS408497	5-144	MZ465772	19-21	ZG466154	4-17	ZW323728	19-39x
EZ426780	21-9x	MS424192	3-8	MZ466097	4-16	ZW200226	1-38	ZW323728	19-43
EZ461125	19-20x	MS432358	5-69	MZ466108	4-14	ZW200305	1-5x	ZW323728	21-12x
EZ472206	19-26	MS465480	5-84	MZ467111	3-18	ZW200362	1-48	ZW323728	21-31x
EZ486797	6-20x	MS809987	1-50	MZ515160	5-130x	ZW200384	22-27x	ZW323728	21-52x
EZ486797	19-64x	MT255420	2-5	MZ515261	19-41x	ZW200621	22-42x	ZW323728	22-30x
EZ495832	17-2	MT297663	2-8	MZ802980	5-17	ZW200687	9-9	ZW324448	22-23
EZ495832	19-76x	MT397225	2-10	SB396641	4-6	ZW200755	21-63x	ZW324448	22-48x
EZ515158	5-60x	MT436860	2-15	SB396652	4-7	ZW200766	21-62x	ZW328577	1-64
EZ515158	5-107x	MT488158	2-4	SB397967	21-29x	ZW200766	22-7x	ZW336868	1-37
EZ515485	6-18x	MT495606	2-11	SB438265	4-15	ZW201150	19-60x	ZW345442	5-13
EZ515485	19-62x	MT495617	2-12x	SC426407	22-31	ZW201150	22-36x	ZW345914	1-55
EZ516464	6-21x	MV248117	5-75	SK210521	4-25	ZW201183	22-22	ZW345982	1-49
EZ516464	19-65x	MV248130	3-9	SK210521	5-136x	ZW201464	1-30x	ZW356883	3-11

# INDEX

Parts No.	Ref. No. & Symbol No.	Parts No.	Ref. No. & Symbol No.	Parts No.	Ref. No. & Symbol No.	Parts No.	Ref. No. & Symbol No.	Parts No.	Ref. No. & Symbol No.
ZW364397	14-4x	ZW447761	6-27x						
ZW366074	21-20x	ZW447761	19-73x						
ZW366377	22-38x	ZW447772	4-31						
ZW371856	5-134	ZW447772	5-129						
ZW371856	19-48	ZW447772	12-5						
ZW374128	6-26x	ZW447772	21-54						
ZW374128	19-72x	ZW447805	21-45x						
ZW375085	12-4	ZW447805	22-26x						
ZW375153	20-9	ZW447840	21-46x						
ZW379405	4-23x	ZW447963	22-10x						
ZW383646	1-35	ZW461935	4-28						
ZW384840	1-76	ZW461935	13-6						
ZW391476	3-7x	ZW462194	19-45x						
ZW392940	9-5	ZW462802	21-66						
ZW396786	1-17	ZW467908	5-38						
ZW397146	5-104x	ZW468112	19-19						
ZW397157	5-123	ZW472274	4-5						
ZW397631	22-5	ZW472274	19-10						
ZW398125	3-5	ZW490228	19-22						
ZW398158	3-12	ZW516611	5-85x						
ZW399295	1-74x	ZW516644	2-18						
ZW403200	4-24	ZW810055	1-57						
ZW403222	2-20								
ZW403301	1-4x								
ZW403312	1-45								
ZW403536	3-13								
ZW403571	22-18x								
ZW406181	20-11x								
ZW406247	6-36x								
ZW408418	22-28								
ZW410231	21-41x								
ZW411660	5-77								
ZW413155	5-41								
ZW413155	5-125x								
ZW413155	9-15								
ZW413155	17-3								
ZW413155	19-80x								
ZW413155	22-6x								
ZW413188	5-83x								
ZW413223	1-71								
ZW413278	5-158x								
ZW413728	9-19x								
ZW413741	5-91x								
ZW413741	6-14x								
ZW413741	6-35x								
ZW413741	9-10								
ZW413785	4-19								
ZW414066	5-108x								
ZW416687	5-88x								
ZW417025	9-17x								
ZW417025	21-58x								
ZW417137	5-7								
ZW417137	5-137								
ZW417148	1-23x								
ZW417150	19-54								
ZW419646	22-17x								
ZW419646	22-40x								
ZW419747	3-3x								
ZW420682	5-95								
ZW421806	9-6								
ZW422965	5-30x								
ZW422965	5-106x								
ZW422965	21-27x								
ZW424056	2-19								
ZW424124	5-153x								
ZW424124	21-51								
ZW424495	5-64								
ZW425981	2-14x								
ZW426587	1-70								
ZW426611	1-26								
ZW426622	1-44								
ZW426655	1-27								
ZW433001	5-54x								
ZW434160	5-45x								
ZW434250	1-19x								
ZW434283	22-41x								
ZW439402	1-12								
ZW439514	5-103x								
ZW439672	22-15x								
ZW440291	19-49								

---

SECTION 3

**SCHEMATIC DIAGRAM**

1. GX-280 SCHEMATIC DIAGRAM
2. GX-280D SCHEMATIC DIAGRAM

GX-280D

	TR105			TR106			TR107			TR108			TR109			TR110			TR111			
	E	C	B	E	C	B	E	C	B	E	C	B	E	C	B	E	C	B	E	C	B	
1.STOP	23.9V	24V	23.9V	24V	24V	24V	24V	24V	24V	24V	24V	24V	24V	24V	24V	0.008V	0.013V	0.028V	0.003V	24V	0.004V	1.STOP
2.FWD	6.19V	24V	3.28V	0.798V	24V	0.737V	0.035V	0.052V	0.10V	0.058V	0.090V	0.80V	0.038V	24V	0.037V	0.047V	0.23V	0.222V	0.045V	24V	0.017V	2.FWD
3.REV	6.85V	24V	4.47V	0.744V	24V	0.786V	0.050V	0.156V	0.827V	0.050V	0.110V	0.80V	0.050V	24V	0.072V	0.047V	0.23V	0.222V	0.045V	24V	0.017V	3.REV
4.F.F	0.017V	0.108V	0.795V	0.018V	0.101V	0.798V	20.5V	24V	0.877V	20.2V	20.4V	20.9V	20.3V	24V	0.016V	0.028V	0.716V	0.016V	24V	0.017V	4.F.F	
5.RWD	0.012V	0.108V	0.786V	0.691V	24V	0.828V	20.2V	24V	0.890V	20.2V	20.3V	20.9V	20.3V	24V	0.011V	0.021V	0.712V	0.011V	24V	0.017V	5.RWD	
6.REC.	6.23V	24V	3.30V	0.770V	24V	0.776V	0.085V	0.203V	0.895V	0.086V	0.145V	0.272V	0.086V	0.208V	0.893V	0.032V	0.046V	0.708V	0.032V	24V	0.034V	6.REC.

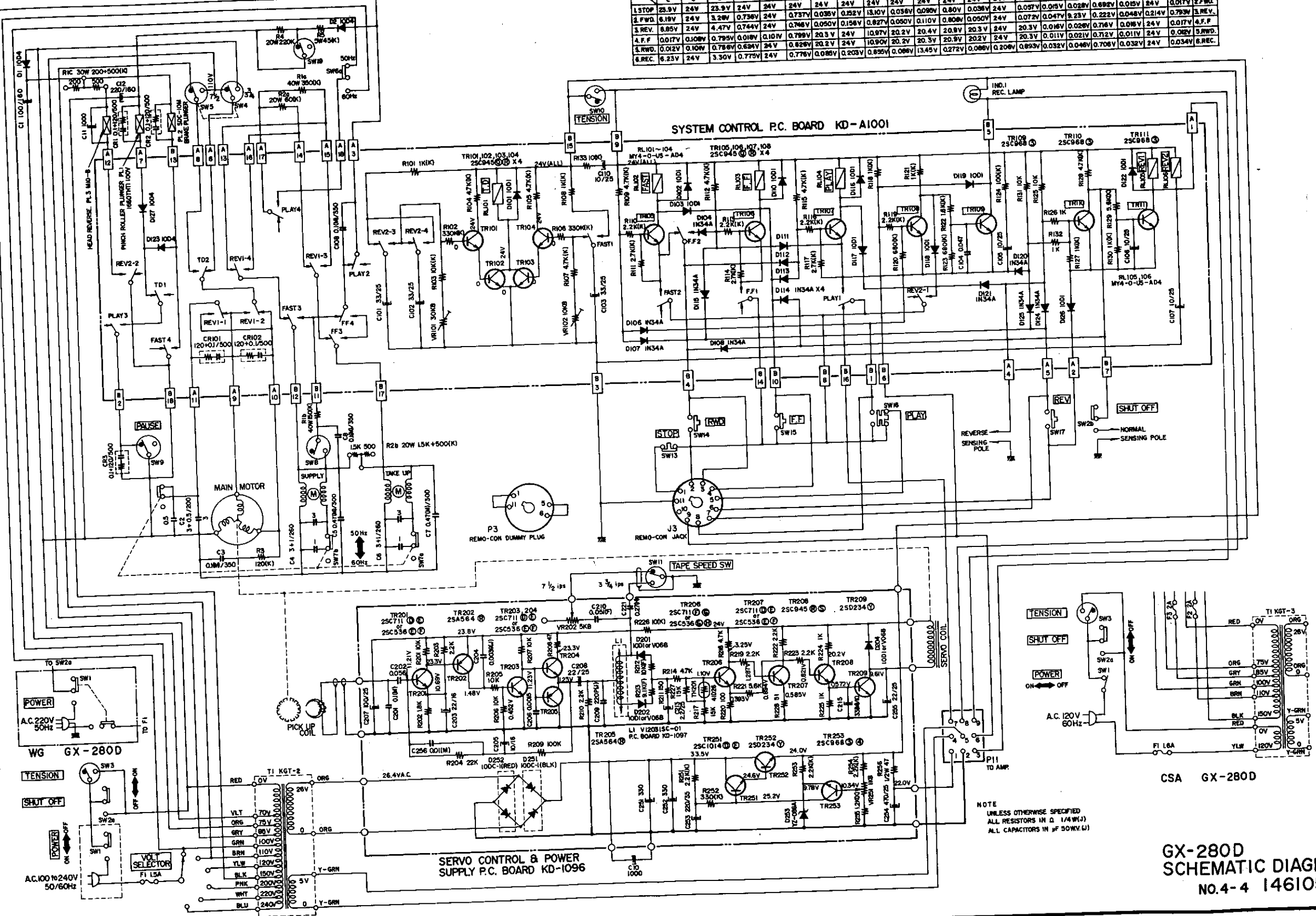

NOTE  
UNLESS OTHERWISE SPECIFIED  
ALL RESISTORS IN Ω 1/4 W(±)  
ALL CAPACITORS IN μF 50V(±)

GX-280D  
SCHEMATIC DIAGRAM  
NO.4-4 1461053A  
2C



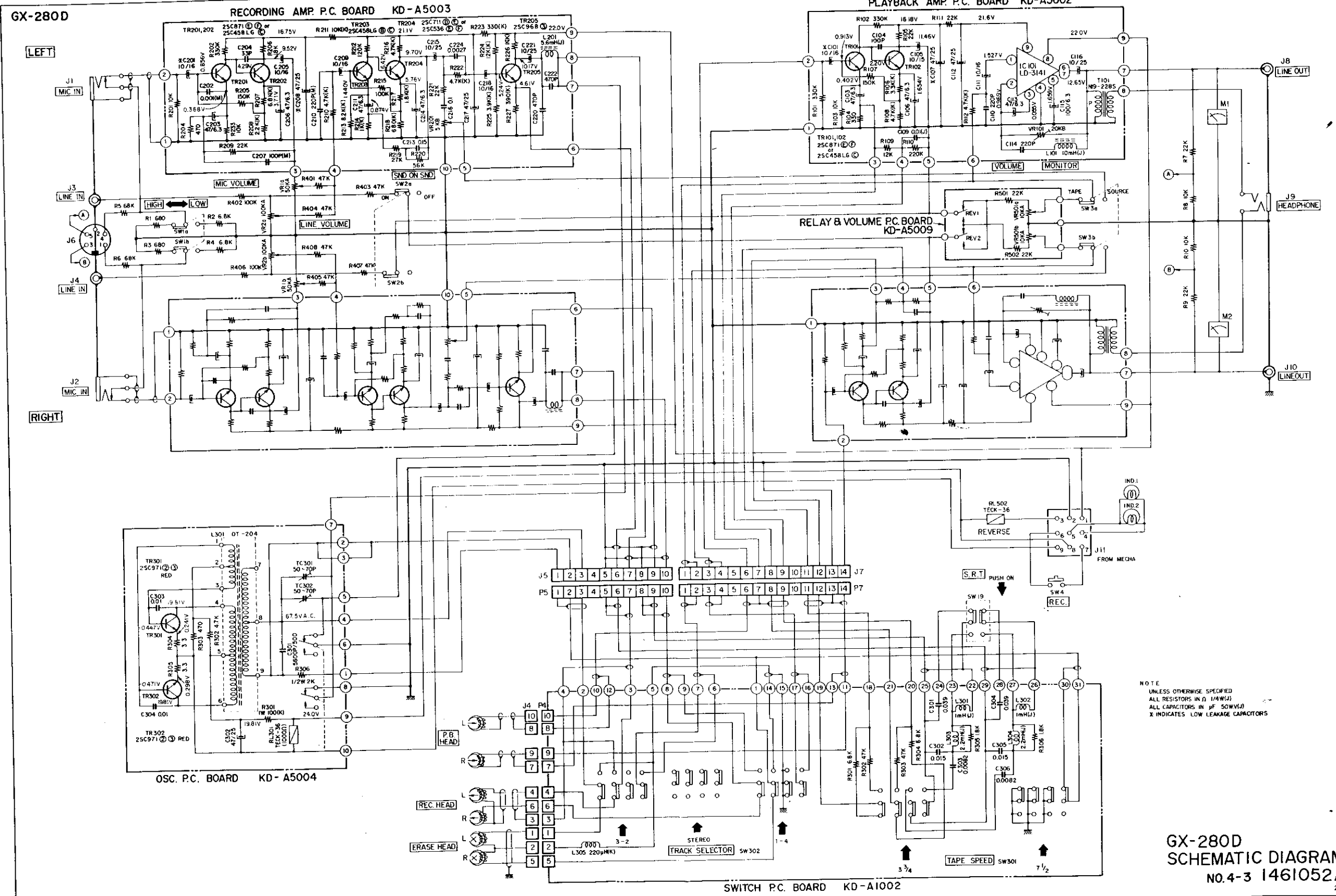

NOTE  
 UNLESS OTHERWISE SPECIFIED  
 ALL RESISTORS IN Ω (1/4W/1/2)  
 ALL CAPACITORS IN μF (50V/10)  
 X INDICATES LOW LEAKAGE CAPACITORS

GX-280D  
 SCHEMATIC DIAGRAM  
 NO.4-3 1461052A

GX-280

TR105		TR106		TR107		TR108		TR109		TR110		TR111	
E	C	B	E	C	B	E	C	B	E	C	B	E	C
STOP	23.9V	24V	23.9V	24V	24V	24V	24V	24V	24V	24V	24V	0.003V	24V
2.FWD	6.19V	24V	3.26V	0.736V	24V	0.737V	0.025V	0.152V	0.10V	0.036V	0.095V	0.80V	0.036V
3.REV	6.85V	24V	4.47V	0.744V	24V	0.746V	0.050V	0.156V	0.827V	0.050V	0.110V	0.806V	0.050V
4.F.F	0.07V	0.108V	0.795V	0.018V	0.101V	0.793V	20.3V	24V	10.97V	20.2V	20.4V	20.9V	20.3V
5.FA	0.012V	0.101V	0.786V	0.624V	24V	0.626V	20.2V	24V	10.50V	20.2V	20.3V	20.9V	20.2V
6.REC	6.28V	24V	3.50V	0.775V	24V	0.776V	0.085V	0.203V	0.85V	0.086V	0.206V	0.893V	0.032V

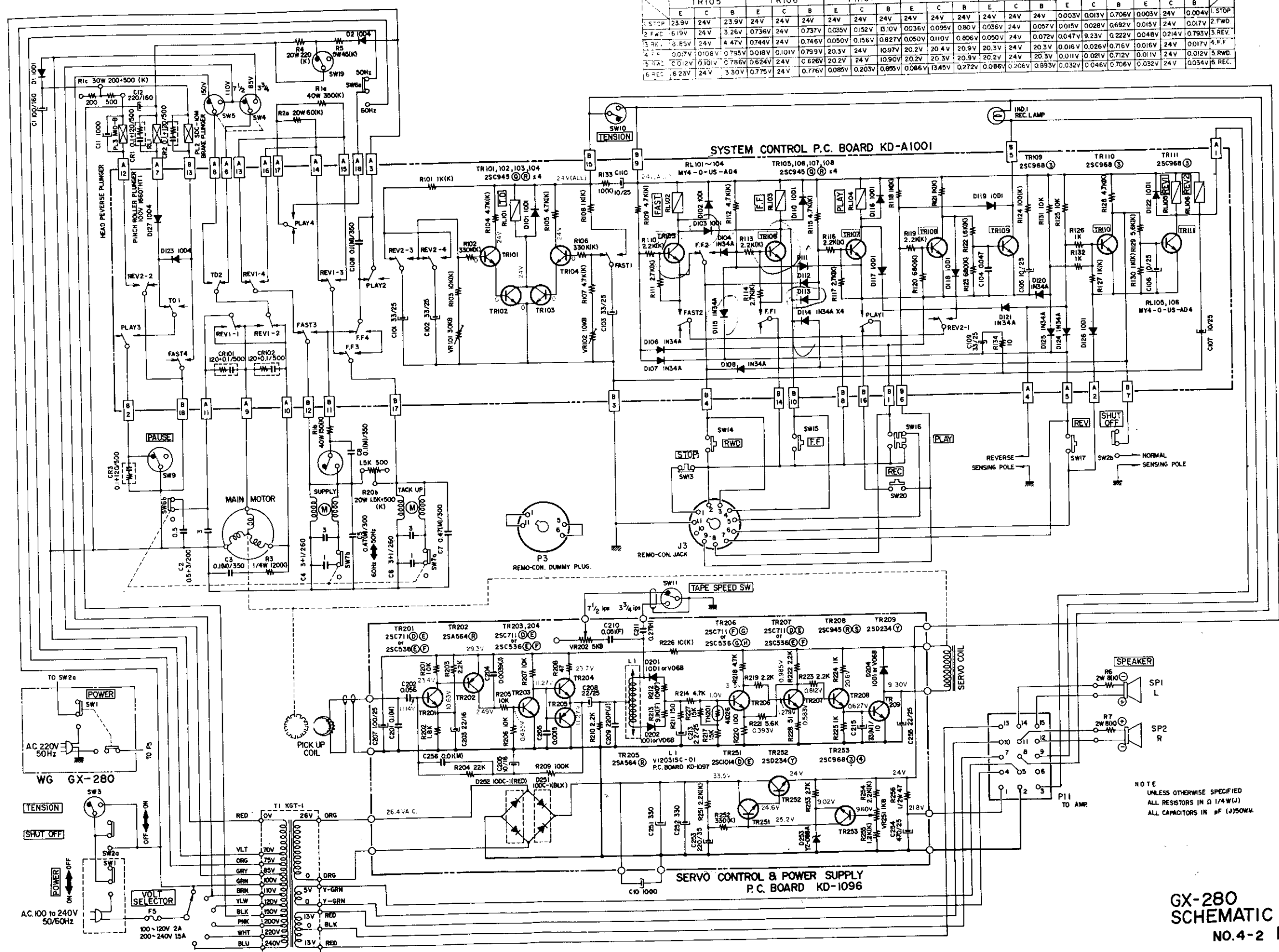

NOTE  
UNLESS OTHERWISE SPECIFIED  
ALL RESISTORS IN Ω (1/4 W (1))  
ALL CAPACITORS IN µF (350V)

GX-280  
SCHEMATIC DIAGRAM  
NO.4-2 1461051A  
2C

