

DENON

Hi-Fi Personal Component System

SERVICE MANUAL

PERSONAL COMPONENT SYSTEM D-77

UNIT No. UDRA-77 (Stereo Receiver)

UNIT No. UCD-77 (Compact Disc Player)

UNIT No. UDR-77 (Cassette Tape Deck)

Europe Model

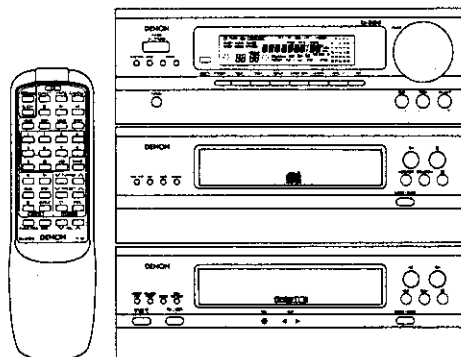

COMPACT
disc
DIGITAL AUDIO

• The D-77 Personal Component System consists of the following:

Stereo Receiver Unit	UDRA-77
Remote Control Unit	RC-800
CD player Unit	UCD-77
Cassette Deck Unit	UDR-77

MAIN FEATURES

- **RDS reception (FM only)**
RDS programs can be easily received (FM only).
- **AM/FM 30-station random preset tuner**
Random presetting permits easy operation and will be convenient for the increased number of FM stations in the future.
- **Independent power amplifier designed for quality sound**
High quality 30 W per channel power amplifier with large speaker terminals.
- **New SDB control**
The Super Dynamic Bass control circuit delivers clear bass sound.
- **Super linear converter and high performance digital filter**
Denon's unique systems for preventing loss of CD sound quality permit excellent sound field reproduction.
- **Editing circuit**
Automatic selection of CD tracks for minimum blank space on the tape when recording.
- **Dolby B and C NR circuits**
For high quality sound in playback and recording.
- **CD SRS circuit**
CDs can be recorded at the touch of a button.
- **Easy-to-use remote control unit**
- **Auto on/off function**
This function switches on the power with just a press of the CD or cassette deck play button.

BEFORE USING

Note the following points before using the D-77.

- **Moving the system**
To prevent short-circuiting or damage of the connection cords, be sure to unplug the power cord and disconnect all connection cords before moving the system.
In addition, always remove CDs before moving the system. Failing to do so may result in scratched CDs.
- **Before switching on the power**
Check again that all connections are proper and that the connection cords are not damaged. Be sure to disconnect the power plug before disconnecting or connecting the connection cords.
- Hum may be produced if a TV set or another audio component is set near this system or their connection cords are nearby. If this happens, try changing the position of the equipment and connection cords.
- Do not move the system abruptly from a cold place to a warm place, since this may cause water droplets (condensation) to form in the equipment, preventing proper operation. If this happens, wait one hour before using the system.

Check that the following parts are included in the package aside from the main unit:

① Operating Instructions	1	⑤ R6P Batteries	2
② FM Indoor Antenna	1	⑥ System Connectors 1 & 2	2
③ AM Loop Antenna	1	⑦ AC Cord	1
④ Remote Controller	1		

NIPPON COLUMBIA CO., LTD.

GENERAL SECTION

TABLE OF CONTENTS

General Section (Page 1 ~ Pages 26)

- Main Features 1
- Before Using 1
- Main Specifications 3
- Operating Instructions 4~26

Receiver Section (Pages 27 ~ Pages 62)

- Disassembly Procedures 27~29
- Block Diagram 30, 31
- Level Diagram 32
- Adjustment 32~34
- Semiconductors 35~44
- Microprocessor Documentation 45~48
- Microprocessor Peripheral Wiring Diagram 49
- Printed Wiring Board, Parts List 50~58
- Remote Control Unit 59
- Wiring Diagram 60
- Schematic Diagram 61
- Exploded View, Parts List 62

CD Player Section (Pages 63 ~ Pages 81)

- Disassembly Procedures 63, 64
- Confirming Method of Servo 65~67
- Semiconductors 68~73
- Printed Wiring Board, Parts List 74~77
- Wiring Diagram 78
- Schematic Diagram 79
- Exploded View, Parts List 80
- Parts List of CD Mechanism Unit 81

Cassette Deck Section (Pages 82 ~ Pages 104)

- Disassembly Procedures 82, 83
- Level Diagram 84
- Block Diagram 85
- Adjustment 86~88
- Semiconductors 89~91
- Microprocessor Documentation 92~94
- Microprocessor Peripheral Wiring Diagram 95
- Printed Wiring Board, Parts List 96~99
- Wiring Diagram 100
- Schematic Diagram 101
- Exploded View, Parts List 102
- Cassette Mechanism 103, 104

Only discs with the mark at the right can be played on this system.



Dolby noise reduction manufactured under license from Dolby Laboratories Licensing Corporation.
"DOLBY" and the double-D symbol  are trademarks of Dolby Laboratories Licensing Corporation.

PACKING & ACCESSORIES PARTS LIST

Ref. No.	Part No.	Part Name	Remarks	Q'ty
● 1	UDR A77	Receiver Unit		1
● 2	UCD 77	CD Player Unit		1
● 3	UDR 77	Cassette Deck Unit		1
● 4	505 0241 005	Cabinet Cover		1
● 5	503 9291 102	:Cushion		1
● 6	503 9292 004	:Top Cushion		1
● 7	501 9279 102	:Master Carton		1
8	GEN 7754	Envelope Sub Ass'y		1 ^S
8-1	505 9125 009	:Poly Cover	240×350	(1)
● 8-2	511 9434 009	Inst. Manual	E, G, F, I, T, E, S, N, L, S, P, O	(1)
8-3	394 0040 004	:Battery(R6P/UM-3) Ass'y		(1)
△ 8-4	206 2108 003	:AC Conn. with Plug	L=1.8 m	(1)
8-5	231 1914 003	Loop Antenna		(1)
8-6	395 0023 008	FM Ant. Ass'y		(1)
8-7	—	—		
8-8	204 6471 002	13 P System Connector		(1)
8-9	204 6316 015	15 P System Connector		(1)
● 9	499 9011 009	:Remote Control	RC-800	(1)

ADVARSEL: USYNLIG LASERSTRÅLING VED ÅBNING, NÅR SIKKERHEDSAFBRYDERE ER UDE AF FUNKTION. UNDGÅ UDSÆTTELSE FOR STRÅLING.

VAROITUS! LAITTEEN KÄYTTÄMINEN MUULLA KUIN TÄSSÄ KÄYTTÖOHJEESSA MAINITULLA TAVALLA SAATTAÄ ALTISTAA KÄYTTÄJÄN TURVALLISUUSLUOKAN 1 YLITÄVÄLLE NÄKYMÄTTÖMÄLLE LASERSÄTEILYLLE.

VARNING- OM APPARATEN ANVÄNDS PÅ ANNAT SÄTT ÄN I DENNA BRUKSANVISNING SPECIFICERATS, KAN ANVÄNDAREN UTSÄTTAS FÖR OSYNLIG LASERSTRÅLNING SOM ÖVERSKRIDER GRÄNSEN FÖR LASERKLASS 1.

SPECIFICATIONS





- **Receiver (UDRA-77)**
 - **Tuner**
 - Reception Frequency Range:** FM: 87.50 MHz to 108.00 MHz
AM: 522 kHz to 1611 kHz
 - Receiving Sensitivity:** FM: 1.5 μ V, 75 ohms (SN ratio 30 dB)
AM: 20 μ V (SN ratio 20 dB)
 - FM Stereo Separation:** 40 dB (1 kHz)
 - **Amplifier**
 - Rated Output Power:** 30 W + 30 W (40 Hz to 20 kHz, 6 ohm)
 - Jacks:** 3.5 mm headphone jack
 - Bass Adjustment:** 100 Hz \pm 8 dB
 - Treble Adjustment:** 10 kHz \pm 8 dB
 - Super Dynamic Bass:** 80 Hz +8 dB
 - Jacks:** PHONO: Input jacks
AUX/DAT: Input jacks, recording output jacks
PROCESSOR: Processor input/output jacks
 - Dimensions (max.):** 273 (W) \times 97 (H) \times 323 (D) mm (10-48/64" \times 3-13/16" \times 12-23/32")
 - Weight:** 5.6 kg (12 lbs 5 oz)
 - Power Supply:** AC 230 V, 50Hz
 - Power Consumption:** 95 W
- **CD Player (UCD-77)**
 - Wow and Flutter:** Below measurable limits (\pm 0.001% W. Peak)
 - Sampling Frequency:** 44.1 kHz
 - Light Source:** Semiconductor
 - Dimensions (max.):** 273 (W) \times 97 (H) \times 295 (D) mm (10-48/64" \times 3-13/16" \times 11-39/64")
 - Weight:** 2.6 kg (5 lbs 12 oz)
- **Cassette Deck (UDR-77)**
 - Type:** Horizontal 4-track, 2-channel auto reverse stereo cassette deck
 - Heads:** 1 hard permalloy recording/playback head
and 1 double-gap ferrite erase head
 - Tape Speed:** 4.75 cm/s
 - Noise Reduction Circuits:** Dolby B and C NR
 - Usable Tapes:** Normal, chrome and metal tapes
 - Dimensions (max.):** 273 (W) \times 97 (H) \times 295 (D) mm (10-48/64" \times 3-13/16" \times 11-39/64")
 - Weight:** 2.9 kg (6 lbs 6 oz)
- **Remote Control Unit (RC-800)**
 - Type:** Infrared pulse
 - Number of Buttons:** 40
 - Dimensions (max.):** 54.5 (W) \times 183 (H) \times 18.5 (D) mm (2-3/16" \times 7-9/16" \times 7/9")
 - Weight:** 100 g (Approx. 4.6 oz) (including batteries)

* Maximum dimensions include controls, jacks, and covers.

(W) = width, (H) = height, (D) = depth

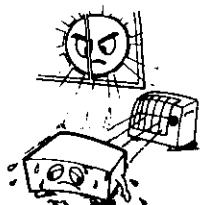
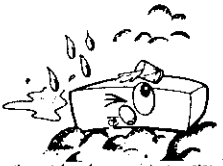
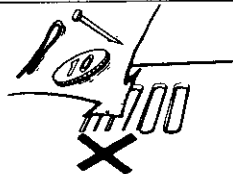
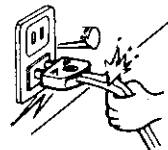
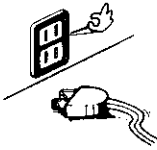
● For improvement purposes, specifications and functions are subject to change without advanced notice.

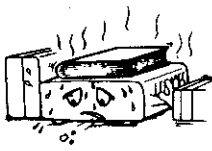
NOTE ON USE / HINWEISE ZUM GEBRAUCH / OBSERVATIONS RELATIVES A L'UTILISATION / NOTE SULL'USO

 <ul style="list-style-type: none"> • Avoid high temperatures. Allow for sufficient heat dispersion when installed on a rack. • Vermeiden Sie hohe Temperaturen. Beachten Sie, daß eine zureichende Luftzirkulation gewährleistet wird, wenn das Gerät auf ein Regal gestellt wird. • Éviter des températures élevées. Tenir compte d'une dispersion de chaleur suffisante lors de l'installation sur une étagère. • Evitate di esporre l'unità a temperature alte. Assicuratevi che ci sia un'adeguata dispersione del calore quando installate l'unità in un mobile per componenti audio. 	 <ul style="list-style-type: none"> • Keep the set free from moisture, water, and dust. Halten Sie das Gerät von Feuchtigkeit, Wasser und Staub fern. • Protéger l'appareil contre l'humidité, l'eau et la poussière. • Tenete l'unità lontana dall'umidità, dall'acqua e dalla polvere. 	 <ul style="list-style-type: none"> • Do not let foreign objects in the set. Keine fremden Gegenstände in das Gerät kommen lassen. • Ne pas laisser des objets étrangers dans l'appareil. È importante che nessun oggetto è inserito all'interno dell'unità.
 <ul style="list-style-type: none"> • Handle the power cord carefully. Hold the plug when unplugging the cord. Gehen Sie vorsichtig mit dem Netzkabel um. Halten Sie das Kabel am Stecker, wenn Sie den Stecker herausziehen. • Manipuler le cordon d'alimentation avec précaution. Tenir la prise lors du débranchement du cordon. • Maneggiare il filo di alimentazione con cura. Agitare per la spina quando scollegate il cavo dalla presa. 	 <ul style="list-style-type: none"> • Unplug the power cord when not using the set for long periods of time. Wenn das Gerät eine längere Zeit nicht verwendet werden soll, trennen Sie das Netzkabel vom Netzstecker. Débrancher le cordon d'alimentation lorsque l'appareil n'est pas utilisé pendant de longues périodes. • Disinnestate il filo di alimentazione quando avete l'intenzione di non usare il filo di alimentazione per un lungo periodo di tempo. 	 <ul style="list-style-type: none"> • Do not let insecticides, benzene, and thinner come in contact with the set. Lassen Sie das Gerät nicht mit Insektiziden, Benzin oder Verdünnungsmitteln in Berührung kommen. • Ne pas mettre en contact des insecticides, du benzène et un diluant avec l'appareil. • Assicuratevi che l'unità non venga in contatto con insetticidi, benzolo o solventi.
	 <p>*(For sets with ventilation holes)</p> <ul style="list-style-type: none"> • Do not obstruct the ventilation holes. Die Belüftungöffnungen dürfen nicht verdeckt werden. • Ne pas obstruer les trous d'aération. • Non coprite i fori di ventilazione. 	 <ul style="list-style-type: none"> • Never disassemble or modify the set in any way. Versuchen Sie niemals das Gerät auseinander zu nehmen oder auf jegliche Art zu verändern. • Ne jamais démonter ou modifier l'appareil d'une manière ou d'une autre. • Non smontate mai, né modificate l'unità in nessun modo.

CAUTION / VORSICHT / ATTENTION / AVVISO

- If the system should smoke or produce strange smells, immediately set the power switch to the STANDBY position, unplug the power cord, and contact your store of purchase.
- Sollte das Gerät Rauch produzieren oder eigenartig riechen, stellen Sie den Netzschalter sofort auf die Position STANDBY (Bereitschaft), ziehen Sie den Netzstecker heraus und kontaktieren Sie Ihren Händler.
- Si de la fumée sort de la chaîne ou des odeurs bizarres, placer l'interrupteur d'alimentation immédiatement sur la position de veille (STANDBY), débrancher le cordon d'alimentation et contacter le distributeur.
- Qualora il sistema dovesse produrre del fumo o degli odori strani, collocate immediatamente l'interruttore di accensione nella posizione STANDBY, disinnestate il filo di alimentazione e rivolgetevi al negozio dell'acquisto.

"SERIAL NO. (UDRA-77) (UCD-77) (UDR-77)
PLEASE RECORD UNIT SERIAL NUMBER ATTACHED TO THE REAR OF THE
CABINET FOR FUTURE REFERENCE"

SAFETY IMPORTANT

WARNING:
TO PREVENT FIRE OR SHOCK HAZARD, DO NOT EXPOSE THIS APPLIANCE TO RAIN OR MOISTURE.

PARA LECTORES DE ESPAÑOL PAGINA 2bis
VOOR NEDERLANDSTALIGE LEZERS PAGINA 2bis
FÖR SVENSKA LÄSARE SIDA 2bis
PARA LEITORES PORTUGUESES PÁGINA 2bis

CLASS 1 LASER PRODUCT
LUOKAN 1 LASERLAITE
KLASS 1 LASERAPPARAT

ADVARSEL: USYNLIG LASERSTRÅLING VED ÅRNING. NÅR SIKKERHEDSÅFBRYDERE ER UDE AF FUNKTION. UNDGÅ UDSÆTTELSE FOR STRÅLING.

VAROITUS: LAITTEEN KÄYTTÄMINEN MUULLA KUIN TÄSSÄ KÄYTTÖOHJEESSA MAINITULLA TAVALLA SAATTAA ALTISTAA KÄYTTÄJÄN TURVALLISUUSLUOKAN 1 YLITÄVÄLLE NÄKYMÄTTÖMÄLLE LASERSTRÄLLELLE.

VARNING: OM APPARATEN ANVÄNDS PÅ ANNAT SÄTT ÄN I DENNA BRUKSANVISNING SPECIFICERATS, KAN ANVÄNDAREN UTSÄTTAS FÖR OSYNLIG LASERSTRÅLNING SOM ÖVERSKRIDER GRÄNSEN FÖR LASERKLASS 1.

"CLASS 1
LASER PRODUCT"



**FRONT PANEL / FRONTPLATTE / PANNEAU AVANT / PANNELLO ANTERIORE
 PANEL FRONTAL / VOORPANEEL / FRAMSIDA / PAINEL FRONTAL**

RECEIVER
 RECEIVER
 RECEBER
 RECEPTEUR
 RICEVITORE

RECEPTOR
 ONTVANGER
 RECEIVER
 RECEBER
 RECEPTOR

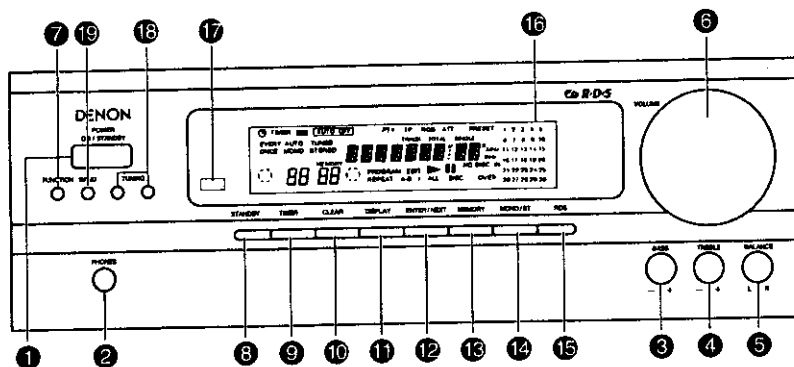

CASSETTE DECK
 CASSETTENDECK
 PLATINE CASSETTE
 PIASTRA A CASSETTE

PLATINA DE CASSETTE
 CASSETTEDECK
 KASSETDÄCKET
 NOMES DAS PEÇAS E FUNÇÕES

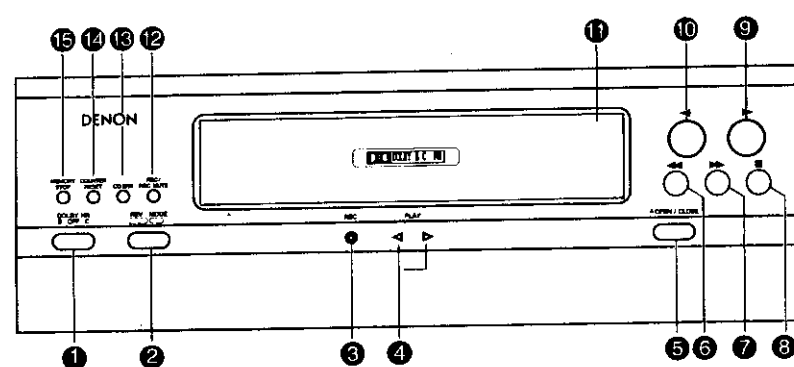

CD PLAYER
 CD-SPIELER
 LECTEUR CD
 DISPLAY DELLA PIASTRA A CASSETTE

REPRODUTOR DE CD
 CD-SPELER
 CD-SPELAREN
 LEITOR DE DISCOS COMPACTOS

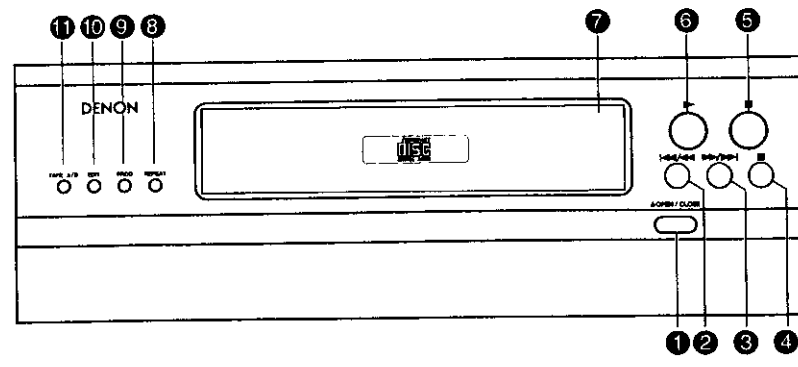

- As an aid to better understanding the operation method, the illustrations used in this manual may differ from the actual system.
- Als Hilfestellung zum besseren Verständnis der Betriebsmethode, erlauben wir uns den Hinweis, daß sich die Abbildungen in dieser Bedienungsanleitung leicht von dem aktuellen System unterscheiden.
- Pour faciliter la compréhension de la méthode de fonctionnement, les illustrations utilisées dans ce manuel peuvent être différentes de celles de la chaîne réelle.
- Per rendere la spiegazione del metodo operativo più facile, le illustrazioni usate in questo libretto delle istruzioni possono differire dal sistema stesso.
- Como ayuda a un mejor entendimiento del método de funcionamiento, las ilustraciones utilizadas en este manual pueden diferir del sistema real.
- Als bijkomende hulp om de bedieningsmethode beter te begrijpen, is het mogelijk dat de afbeeldingen die in deze handleiding zijn gebruikt verschillen van het eigenlijke systeem.
- Illustrationerna i bruksanvisningen hjälper dig förstå de olika funktionerna. Studera dem noga. (Vissa illustrationer kan skilja sig lite grann från din apparat.)
- Como ajuda para uma melhor compreensão do método de funcionamento, as ilustrações utilizadas neste manual podem diferir do verdadeiro sistema.

CONTENTS

1 Main Features	4	(Single Side Playback, Two-Side Playback and Continuous Playback)	17
2 Before Using	4	10 Recording Cassette Tapes	18
3 Antenna Connections	4	11 Playing CDs	18~21
4 Connections	5	• Compact Discs	18
5 Part Names and Functions		• Regular Play	19
• Receiver	6	• Various CD Play Functions	19
• Cassette Deck	6	• Edited Recording onto Sides A and B of a Tape	21
• CD Player	7	12 Remote Control Unit	22
• Display	7, 8	13 Important Information	23
6 Listening to Radio Broadcasts	9~11	14 Specifications	23
7 Using the Timer	11~16	15 Troubleshooting	24
8 Cassette Deck	16	DENON Service Network	92, 93
• Before Recording and Playback	16		
9 Playing Cassette Tapes			

Check that the following parts are included in the package aside from the main unit:

- ① Operating Instructions 1
- ② FM Indoor Antenna 1
- ③ AM Loop Antenna 1
- ④ Remote Controller 1
- ⑤ R6/AA Batteries 2
- ⑥ System Connectors 1 & 2 2
- ⑦ AC Cord 1

1 MAIN FEATURES

- **RDS reception (FM only)**
RDS programs can be easily received (FM only).
- **AM/FM 30-station random preset tuner**
Random presetting permits easy operation and will be convenient for the increased number of FM stations in the future.
- **Independent power amplifier designed for quality sound**
High quality 30 W per channel power amplifier with large speaker terminals.
- **New SDB control**
The Super Dynamic Bass control circuit delivers clear bass sound.
- **Super linear converter and high performance digital filter**
Denon's unique systems for preventing loss of CD sound quality permit excellent sound field reproduction.

- **Editing circuit**
Automatic selection of CD tracks for minimum blank space on the tape when recording.
- **Dolby B and C NR circuits**
For high quality sound in playback and recording.
- **CD SRS circuit**
CDs can be recorded at the touch of a button.
- **Easy-to-use remote control unit**
- **Auto on function**
This function switches on the power with just a press of the PRESET CALL and CD or cassette deck play button. The power also turns on automatically when the PRESET button and the number buttons in the tuner section of the remote control unit are pressed.

2 BEFORE USING

- Note the following points before using the D-77
- **Moving the system**
To prevent short-circuiting or damage of the connection cords, be sure to unplug the power cord and disconnect all connection cords before moving the system. In addition, always remove CDs before moving the system. Failing to do so may result in scratched CDs.
 - **Before switching on the power**
Check again that all connections are proper and that the connection cords are not damaged. Be sure to disconnect the power plug before disconnecting or connecting the connection cords.

- Hum may be produced if a TV set or another audio component is set near this system or their connection cords are nearby. If this happens, try changing the position of the equipment and connection cords.
- Do not move the system abruptly from a cold place to a warm place, since this may cause water droplets (condensation) to form in the equipment, preventing proper operation. If this happens, wait one hour before using the system.

3 ANTENNA CONNECTIONS

Connecting the Included Antennas

AM Loop Antenna
Assemble the included AM loop antenna as shown in the diagram, separate it as far from the system as possible, and place it in a position that provides the best reception. In some cases, reception is better if the polarities of the connections are reversed. AM broadcasts will not be received well if the loop antenna is not connected or if it is connected but is located near a metal part. Attach the loop antenna even when using an outdoor AM antenna.

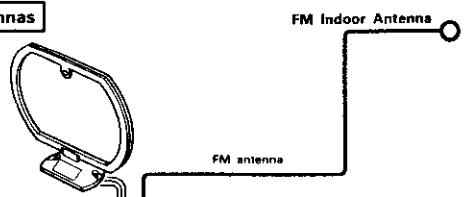

- Connect the included FM indoor antenna to the FM antenna terminal, tune in an FM station, then find the position at which distortion and noise is minimum and fasten the ends of the antenna in that position using tape or pins. Disconnect this antenna when using an outdoor antenna.

Connecting an Outdoor Antenna

Use an outdoor antenna if reception cannot be heard clearly with the included antenna. Change the location, height, and direction of the antenna to find the position of best reception, then fix the antenna in that position.

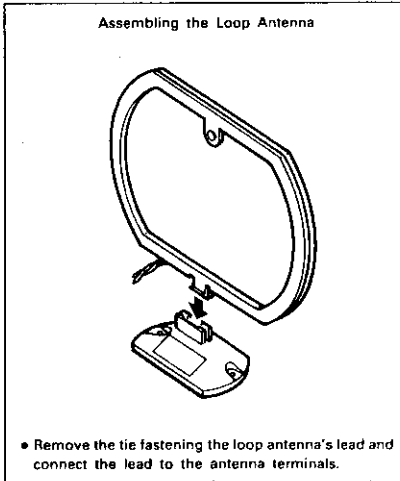

- Remove the tie fastening the loop antenna's lead and connect the lead to the antenna terminals.
- Separate the FM and AM antenna wires from the system connector wires.

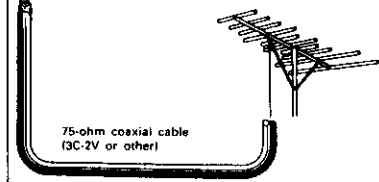

- Connect the outdoor antenna using 75-ohm coaxial cable. This will help shield the antenna from external noise.
- **Places for Installing Outdoor Antennas**
 - Install the outdoor antenna facing a broadcast station's transmission antenna. When surrounded by buildings or hills, place the antenna in the location which provides best reception and try changing the direction of the antenna to obtain optimum reception.
 - Do not install the antenna under power lines. It is extremely dangerous for the antenna to come into contact with a power line.
 - Install away from roads and train tracks to prevent noise from cars and trains.
 - Do not install the antenna too high, as it may be hit by lightning.

4 CONNECTIONS

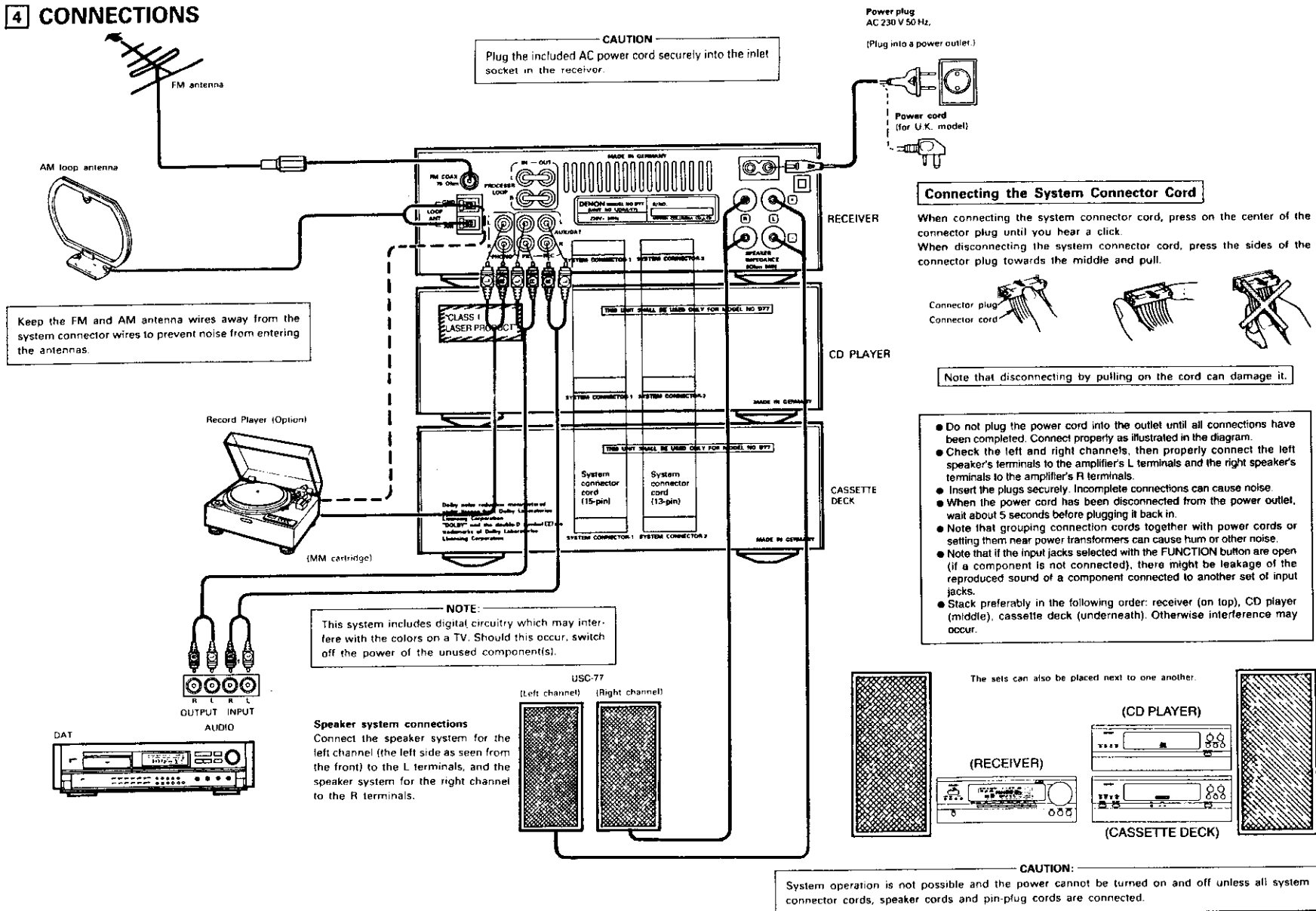

5 PART NAMES AND FUNCTIONS

RECEIVER

- 1 **POWER ON/STANDBY switch**
When pressed once, the power is turned on and the display lights. Also, this power switch can be used to turn the power of all the units on and off.
- 2 **PHONES jack**
When using headphones, plug them in here. The sound from the speakers is cut when headphones are plugged in.
- 3 **BASS control**
Use this control to adjust the bass.
- 4 **TREBLE control**
Use this control to adjust the treble.
- 5 **BALANCE control**
Use this control to adjust the balance of the volume between the left and right channels. The volume is the same for the left and right channels when the control is at the center.
- 6 **VOLUME control**
This control adjusts the overall volume. Turn clockwise (↻) to increase the volume, counterclockwise (↺) to decrease it.
- 7 **FUNCTION button**
Use this to select the program source. The selection changes in the order of TUNER, TAPE, CD, AUX and PHONO.

NOTE: The auto function serves to automatically switch the function when the operation buttons are pressed on each unit.
Tuner: BAND button
CD: Play button (▶)
Deck: Play buttons (▶ and ◀)
(Note that the auto function will not operate unless a tape is loaded in the deck.)
- 8 **STANDBY button**
Press this button to cause the timer to operate at the set time. When the timer has been set, pressing this button will light up the display's timer standby indicator (⏸), and pressing it again will switch off the standby indicator. The timer will not function when the standby indicator is off.
- 9 **TIMER button**
This is used to set the timer.
- 10 **CLEAR button**
This button is used to change the current time setting or the contents of the set timer.

- 11 **DISPLAY button**
Use this switch to switch between the function and time display. For example, when the function is set to the tuner, the display switches between the reception frequency and time.
When RDS stations or stations for which you have written characters yourself and stored them in the memory are tuned in, press this button once to display the frequency, then press again to display the time.
- 12 **ENTER/NEXT button**
This is used when setting the timer, setting the current time, and when advancing to the next operation.
- 13 **MEMORY button**
This button is used when presetting FM and AM stations.
- 14 **MONO/ST (FM Stereo mute/mono) button**
This button will not function when receiving AM broadcasts. (For FM reception)
AUTO: Use this mode to receive FM broadcasts in (mute): stereo.
("AUTO" appears on the display.) The muting circuit is activated to cut the hiss noise between stations.
MONO: In this mode, FM broadcasts are received in monaural, regardless of whether they are broadcast in monaural or stereo.
Set to the mono mode if there is much noise in the stereo mute mode (with "AUTO" displayed) or if the signals are weak.
- 15 **RDS button**
Use this button to automatically tune to stations using the radio data system.
- 16 **DISPLAY**
The display indicates a wide variety of information including: functions and SDB of the amplifier, frequency and reception conditions of the tuner, number of tracks and time of the CD, and the counter of the tape deck.
- 17 **Remote control sensor**
The remote control unit is pointed toward this sensor and operated.
- 18 **TUNING UP and DOWN buttons**
Use these to tune in FM or AM stations and when setting the time and timer.
- 19 **BAND (FM/AM) button**
With each press, the band is switched in the order of FM, AM, FM and so on.

CASSETTE DECK

- 1 **DOLBY NR selection switch**
Use this switch to select the Dolby NR mode: off, B type or C type. During playback, set this switch to the same mode in which the tape was recorded.
- 2 **REV MODE switch**
Use this switch to set the reverse mode to one of the following modes: ↔ (single side mode), ↔ (two-side mode), or ↔↔ (continuous mode). Refer to Page 16 for details.
- 3 **REC LED**
This LED lights in the recording mode.
- 4 **PLAY LED**
This LED lights in the play mode.
- 5 **▲ OPEN/CLOSE button**
Press this button to open and close the cassette tray. The button also works in the standby condition. When this button is pressed in the standby condition, the power is automatically switched on.
- 6 **◀◀ (rewind) button**
Press this button to rewind the tape. Also, if pressed during playback in the ▶ (forward) direction, the tape is rewound to the beginning of the currently playing selection. If pressed during playback in the ◀ (reverse) direction, the tape is forwarded to the beginning of the next selection (on the back side of the tape).
- 7 **▶▶ (fast-forward) button**
Press this button to fast forward the tape. Also, if pressed during playback in the ▶ (forward) direction, the tape is fast forwarded to the beginning of the following selection. If pressed during playback in the ◀ (reverse) direction, the tape is rewound to the beginning of the currently playing selection (on the back side of the tape).
- 8 **■ (stop) button**
Press this button to stop the moving tape.
- 9 **▶ (forward play) button**
Press this button to begin playback in the forward direction.
When this button is pressed in the standby condition, the power is automatically switched on and the deck plays.
- 10 **◀ (reverse play) button**
Press this button to begin playback in the reverse direction.
When this button is pressed in the standby condition, the power is automatically switched on and the deck plays.

- 11 **Cassette tray**
The cassette tray opens outward when the OPEN/CLOSE button is pressed. Insert the cassette tape with the side on which the tape is exposed facing away from you. To close the cassette tray, press the OPEN/CLOSE button again.
- 12 **REC/REC MUTE (recording) button**
To record, press the REC/REC MUTE button (hold it in for at least 0.5 seconds), then press the ▶ play button only. If only the REC/REC MUTE button is pressed, the deck is set to the recording pause mode. If this button is pressed again, or pressed during recording, the recording mute mode is set for approximately 5 seconds, after which the deck is set to the recording pause mode.

Recording pause mode

When the play button of the CD player is pressed in the recording pause mode, the CD begins to be recorded.

- 13 **CD SRS (CD synchronized recording system) button**
Use this button for simple CD synchronized recording. Refer to Page 18.
- 14 **COUNTER RESET button**
Press this button to reset the tape counter on the tuner unit's display to "0000".
- 15 **MEMORY STOP button**
When this button is pressed and "MEMORY" is displayed on the receiver unit's display, when the ▶▶ or ◀◀ button is pressed the tape automatically stops at the point where the counter reads "0000". (The search operation is performed if the ▶▶ or ◀◀ button is pressed during playback, so first press the STOP button, then press the ▶▶ or ◀◀ button.)

NOTE:

- After the power cord is plugged into an outlet, a mechanical sound is produced from the cassette deck when the power switch is pressed on the first time only. This is the sound of the cassette mechanism being set to the proper operating position, and is not a problem with the deck.

CD PLAYER

- 1 **▲ OPEN/CLOSE button**
Press this button to open the disc tray. Press once to open the disc tray forward, then press again to close the disc tray. This button also operates in the standby mode.
- 2 **⏮/⏪ (automatic/manual search backward button)**
Press this button to move the pickup back to the beginning of the desired track.
Press in the play, stop, or pause mode to move back a number of tracks equal to the number of times the button is pressed.
- 3 **⏭/⏩ (automatic/manual search forward button)**
Press this button to move the pickup forward to the beginning of the desired track.
Press in the play, stop, or pause mode to move forward a number of tracks equal to the number of times the button is pressed.
* The automatic search function is set if button 2 or 3 is released within 0.5 seconds, and the manual search function is set if the button is held in for more than 0.5 seconds.
* Buttons 2 and 3 do not function in the pause mode.
- 4 **■ Stop button**
Press this button to stop CD play.
- 5 **⏸ Pause button**
Press this button to stop CD play temporarily.
Press the play button to resume CD play.
- 6 **▶ Play button**
Press this button to start playing the disc. If pressed when the disc tray is open, the disc tray closes and playback begins. Pressing this button in the standby mode automatically switches on the power and plays the disc.

- 7 **Disc tray**
Compact discs are loaded to the disc tray.
- 8 **REPEAT button**
Press this button for repeat play.
- 9 **PROGRAM Button**
Use this button to play the desired tracks in the order you wish.
- 10 **EDIT button**
Press this button for edited recording (dividing the tracks to be recorded to fit onto sides A and B of a tape according to the length of the tape).
- 11 **TAPE A/B button**
Press this button during editing to switch the display between the display of program contents for tape side A and the display for tape side B.

RECEIVER DISPLAY

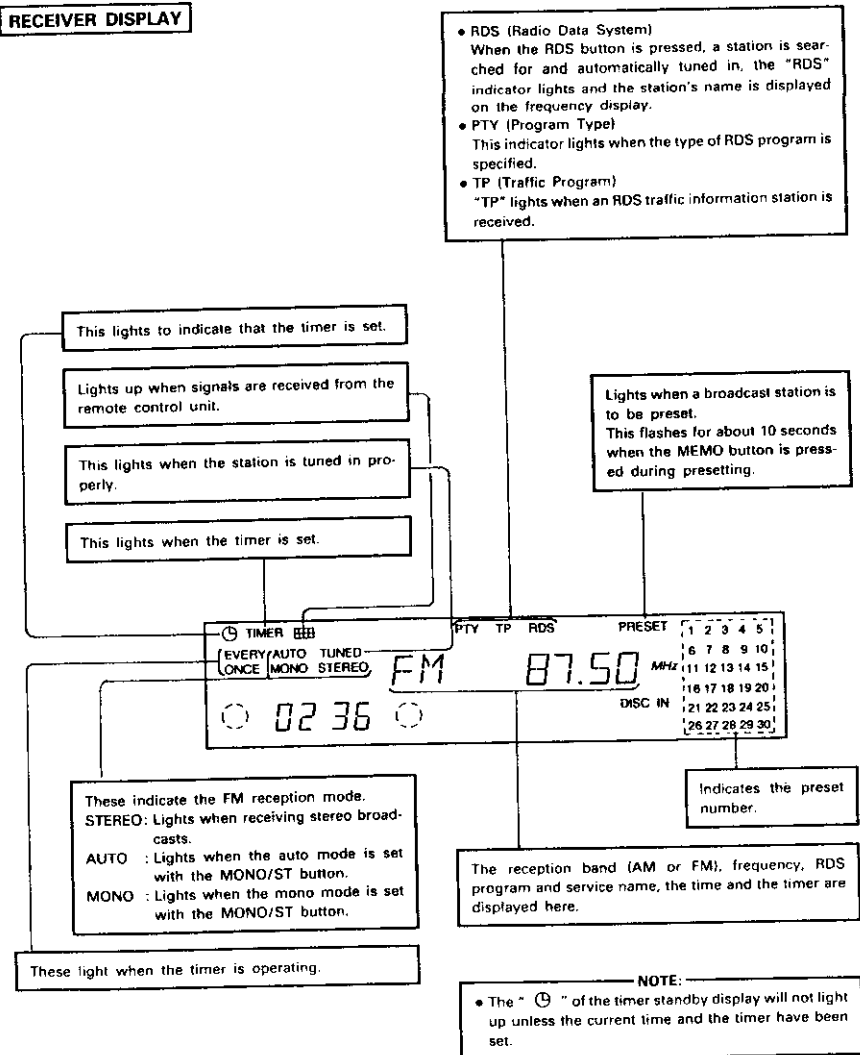

CASSETTE DECK DISPLAY

• This is displayed on the display of the receiver unit (UDRA-77)

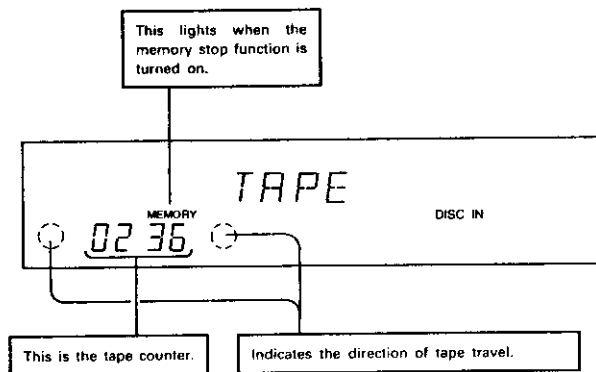

USING THE TAPE COUNTER

- The counter is reset to "0000" when the tape is ejected and loaded, and when the COUNTER RESET button is pressed.
- Making a memo of the contents of a recording and the range of the counter numbers while you are recording or playback back a tape will be convenient when you search for a portion of the tape you would like to listen to or when you search for the next portion you would like to record.

Dolby noise reduction manufactured under license from Dolby Laboratories Licensing Corporation. "DOLBY" and the double-D symbol are trademarks of Dolby Laboratories Licensing Corporation.

CD PLAYER DISPLAY

• This is displayed on the display of the receiver unit (UDRA-77)

Track number display
00 is displayed when the disc data cannot be read properly.
When a disc is loaded:
• The total number of tracks is displayed in the stop mode.
• The track number is displayed in the play and program modes.
• [[or]] is displayed when the innermost or outermost section of the disc is reached in the manual search mode.

Time display
0000 is displayed when the disc data cannot be read properly.
When a disc is loaded:
• The elapsed playing time is displayed in the stop mode.
• The elapsed time for the track currently playing is displayed in the play and pause modes.
• The elapsed time for the programmed tracks is displayed in the program mode.

PROGRAM lights during the programmed selection mode.

Tape type and remaining time display
During the editing operation, C 00 lights and the tape time is displayed.

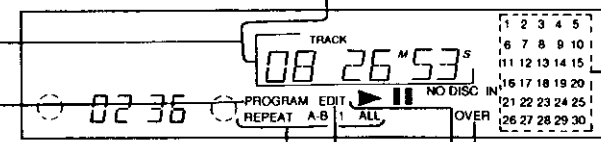

During the editing operation, EDIT A TAPE lights up, the remaining time for side A of the tape is indicated on the time section of the display, the track numbers set for side A light on the calendar section of the display, while the track numbers set for side B flash. When the TAPE A/B button is pressed, A goes off, B lights, and the remaining time and track numbers set for side B are indicated in the same way.

This lights when there are 31 or more tracks on the disc.

▶ PLAY lights when the disc is playing, and II PAUSE lights when in the pause mode.

The indicators switch as follows when the REPEAT button is pressed in the play mode:
REPEAT 1: REPEAT 1 (single track repeat) The repeated track number lights on the music calendar.
REPEAT ALL: REPEAT ALL (all tracks repeat) The track numbers of the tracks on the disc light.
Third press: REPEAT A-
Fourth press: REPEAT A-B
Fifth press: No display
• When track 31 or higher is repeated in 1-track repeat, the TRACK number flashes.

Music calendar display
This indicates the track numbers on the disc to a maximum of 30. The track numbers go off after the corresponding tracks are played. In the program mode, the track numbers of the programmed tracks are indicated to a maximum of 30. All track numbers from 1 to 30 light when the disc data cannot be read properly.

• NO DISC lights on the display if no disc is loaded, or if the disc is loaded upside-down or is heavily scratched or dirty.

6 LISTENING TO RADIO BROADCASTS

(Check that connections are proper, referring to Pages 5)

TUNING

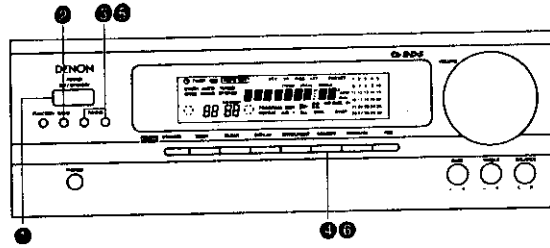

Example: Tuning to 87.50 MHz, FM

1	Set the VOLUME control to the minimum position, then press the POWER button of the receiver.	POWER ON/STANDBY 	
2	Select the FM band with the BAND button.	BAND 	Set to FM. FM 90.00
3	Use the UP and DOWN buttons to set the frequency to 87.50 MHz.	TUNING DOWN UP 	Lights up when the station is tuned in. TUNED FM 87.50

Presetting FM and AM Stations

Example: Presetting the (currently tuned) FM 87.50 MHz to preset number 3

4	Press the MEMORY button. "PRESET" flashes for 10 seconds.	MEMORY 	TUNED FM 87.50 PRESET 3 Flashes
5	Use the TUNING UP and DOWN buttons to call up the number to which you want to preset the station. Or, directly press the number buttons on the remote control unit. The preset number will flash.	TUNING DOWN UP 	TUNED FM 87.50 PRESET 3 Flashes
6	Press the MEMORY button while "PRESET" is flashing.	MEMORY 	TUNED FM 87.50 PRESET 3 set the preset number 3.

Up to 30 FM and AM stations can be preset at random using this procedure.
Note: The character writing mode is set if the MEMORY button is pressed in for over 3 seconds.

Auto Tuning

- When the TUNING buttons are pressed, the frequency changes in steps of 50 kHz for FM, 9 kHz for AM.
- If the TUNING UP or DOWN button is held in for more than 0.5 second, the frequency continues to change when the button is released. The next station is tuned in automatically and the tuning stops there. The auto tuning might not stop when a weak signal is received at the antenna. At this time the TUNED display will not light. To stop the auto tuning, press the UP or DOWN button again.

Listening to Preset Stations

Example: Listening to the FM station preset at number 3

1	Press the TUNER BAND button on the remote control unit.		
2	Press button "3" on the remote control unit.		

FM Stereo Reception

- When the MONO/ST button is pressed (which lights the AUTO indicators) and an FM stereo broadcast is received, the STEREO indicator lights and the station is received in stereo. If the MONO indicator is lit by pressing the MONO/ST button, the STEREO indicator goes off and the station is received in monaural.

Notes on Presetting

- When an FM station is preset, the auto or monaural mode is also set, so check the display before presetting the station.
- If a station is preset to a number at which another station has previously been preset, the previous station is cleared and the new station is preset.
- If the power cord is unplugged, the preset memory is not cleared immediately, but will be cleared if the cord is left unplugged over a long period. Should this happen, preset the stations again.



Receiving RDS broadcasts (FM only)

1	Press the BAND button and set the FM band.	FM 87.50
2	Press the RDS button once.	Flashes (--RDS--) "RDS" blinks
3	Press the TUNING UP or DOWN button.	Flashes FM 87.50 "RDS" blinks
4	The station is tuned in.	"RDS" lights after 5 seconds of flashing. Station name

Once the station is tuned in, "RDS" flashes for 5 seconds and the program service name is displayed. When another station is desired, press the UP or DOWN button of TUNING while "RDS" is flashing and start the tuning.

NOTE: If no RDS station is found, "NO RDS" is displayed.

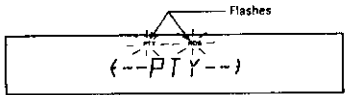
PTY Search

<p>1 Press the RDS button twice.</p>	 <p>("PTY" and "RDS" flash, and "--PTY--" is displayed.)</p>
<p>2 Press the PRESET UP or DOWN button on the remote control unit to select the type of program. (One of the 15 types listed below can be selected.)</p>	
<p>3 Press the TUNING UP or DOWN button.</p>	<p>"PTY" and "RDS" light after 5 seconds of flashing.</p>
<p>4 The station is tuned in.</p>	 <p>Once the station is tuned in, "RDS" and "PTY" flash for 5 seconds and the program service name is displayed. When the UP or DOWN button of TUNING is pressed while "RDS" and "PTY" are flashing, tuning is started again.</p>
<p>NOTE: If no program of the specified type is found, "NO PROG" is displayed.</p>	

TP Search

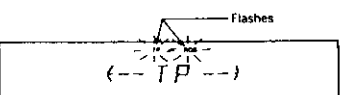
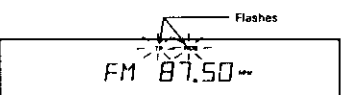
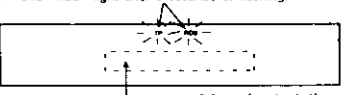
<p>1 Press the RDS button 3 times.</p>	
<p>2 Press the TUNING UP or DOWN button of TUNING.</p>	
<p>3 Broadcast reception.</p>	<p>"TP" and "RDS" light after 5 seconds of flashing.</p>  <p>Once the station is tuned in, "RDS" and "TP" flash for 5 seconds and the program service name is displayed. When the UP or DOWN button of TUNING is pressed while "RDS" and "TP" are flashing, tuning is started again.</p>
<p>NOTE: "NO PROG" is displayed when there is no traffic information broadcast station.</p>	

Programs

NEWS	(News)	VARIED	(Varied)
AFFAIRS	(Current Affairs)	POP M	(Pop Music)
INFO	(Information)	ROCK M	(Rock Music)
SPORT	(Sport)	MOR M	(M.O.R. Music)
EDUCATE	(Education)	LIGHT M	(Light Classics)
DRAMA	(Drama)	CLASSICS	(Serious Classics)
CULTURE	(Culture)	OTHER M	(Other Music)
SCIENCE	(Science)		

NOTE:

The D-77 is designed so that RDS broadcasts can be received. In some countries and areas, however, no RDS broadcasts are offered.

- "PTY" is a code which identifies the type of program.
- "TP" is a code which identifies the station providing the traffic information.
- "CT" is a signal providing time data in one minute units.
- Some stations which provide RDS broadcasts do not broadcast CT signals, in which case the time display cannot be corrected by pressing the CT button on the remote control unit.

Writing Characters

The D-77 includes a function for writing characters.

Example: Writing the characters "MY RADIO" for the station at FM 107.70 MHz and storing this at preset channel 5

1	Use the BAND button and the TUNING UP and DOWN buttons to display FM 107.70MHz.	
2	Press the MEMORY button for at least 3 seconds so that "PRESET" flashes on the display.	
3	Use the TUNING UP and DOWN buttons to select preset channel 5.	
4	Press the ENTER/NEXT button. The "-" begins to flash.	
5	Use the TUNING UP and DOWN buttons to select the character "M", then press the PRESET UP button on the remote control unit. The "-" stops flashing, and the "M" in the second place starts flashing.	
6	Use the TUNING UP and DOWN buttons to select the character "Y", then press the PRESET UP button on the remote control unit.	
7	Repeat this procedure to write "MY RADIO", then press the ENTER/EXIT button. "PRESET" stops flashing and the character writing mode is cancelled.	

The characters which can be written are shown below.

- The characters change in the direction of the arrow when the PRESET UP button is pressed, in the opposite direction when the PRESET DOWN button is pressed.
- The character sequence starts over from A each time a character is set.

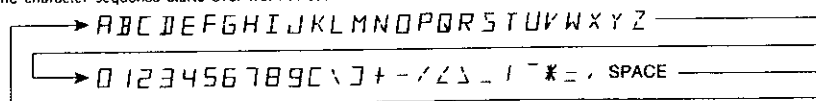

NOTES:

- The cursor can be moved to correct a character by pressing the PRESET button during the character writing mode.
- If the frequency of the station for which characters have been written is the same as the frequency of a PS broadcasting station, the characters are rewritten by the PS signal.
- Characters can also be written in the same way when in the AM mode.

7 USING THE TIMER

Setting the Timer

- Be sure to set the current time.
 - Regular timer: The power can be switched on and off once every day at the same time. (Wake-up music)
 - Sleep timer: The power can be set to turn off in up to 60 minutes in steps of 10 minutes using the remote control unit. (Bedtime music)
- Be sure to preset stations before setting the timer.
 Refer to "Presetting FM and AM Stations" on Page 9.
- Turn the standby switch off when not using the timer.

Power Failure

Should a power failure occur or if the power cord becomes unplugged from the power outlet, "00:00" will flash on the time display. If this happens, reset the current time. (Reset the current time and timer settings. If "00:00" was displayed, also reset the stations preset on the tuner.) The standby mark starts flashing if there is a power failure or the power cord is unplugged while the standby mark is lit. If this happens, reset the time and the timer. (If the display reads "00:00", also reset the tuner's preset channels.) To make the standby mark stop flashing, press the TIMER button, then press the TIMER or CLEAR button while "FM/AM" is displayed.

Setting the Current Time (A 24-hour clock display is used.)

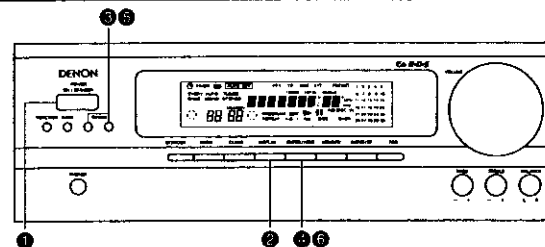

Example: Setting to 19:30 (7:30 p.m.)

1	Press the POWER button of the receiver.		
2	Depress the DISPLAY button for 3 seconds or longer.		The hour's place flashes. (All places flash if the time has already been set.)
3	Set the hours with the UP and DOWN buttons.		The set places flashes.
4	Press the ENTER/NEXT button.		The minutes' places flashes.
5	Set the minutes with the UP and DOWN buttons.		The set places flashes.
6	Press the ENTER/NEXT button at the sound of a time signal. The time display lights steadily and the clock starts keeping the time.		The display lights steadily and the clock starts to count from 0 seconds.

Setting the Timer

(Preset the FM and AM stations in advance)

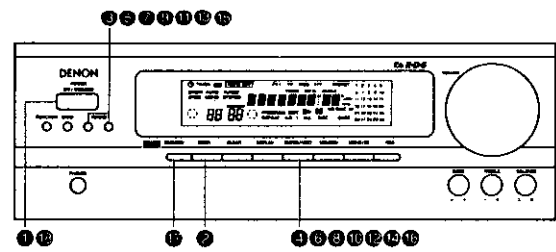

Example: Setting the timer to turn on at 12:35 and off at 12:56.
 90.00 MHz FM is being received on preset number "1".
 87.50 MHz FM is set to preset number "3".

1	Press the POWER button.	POWER ON/STANDBY	TIMER	Flashes TIMER EVERY
2	Press the TIMER button.	TIMER		Flashes TIMER EVERY
3	Press the UP and DOWN buttons to display "EVERY".	TUNING DOWN UP		Flashes TIMER EVERY
4	Press the ENTER/NEXT button.	ENTER/NEXT		TIMER EVERY FUNC
5	Press the UP and DOWN buttons to display "TUNER".	TUNING DOWN UP		TIMER EVERY TUNER
6	Press the ENTER/NEXT button.	ENTER/NEXT		TIMER EVERY TUNED FM 87.50
7	Use the UP and DOWN buttons to set the preset number 3.	TUNING DOWN UP		Flashes TIMER EVERY
8	Press the ENTER/NEXT button.	ENTER/NEXT		Lights up TIMER EVERY
9	Use the UP and DOWN buttons to set the hour at which the timer is to switch on.	TUNING DOWN UP		Flashes TIMER EVERY
10	Press the ENTER/NEXT button.	ENTER/NEXT		Flashes TIMER EVERY

11	Use the UP and DOWN buttons to set the minutes at which the timer is to switch on.	TUNING DOWN UP	Flashes TIMER EVERY
12	Press the ENTER/NEXT button.	ENTER/NEXT	Flashes TIMER EVERY
13	Use the UP and DOWN buttons to set the hour at which the timer is to switch off.	TUNING DOWN UP	Flashes TIMER EVERY
14	Press the ENTER/NEXT button.	ENTER/NEXT	Flashes TIMER EVERY
15	Use the UP and DOWN buttons to set the minutes at which the timer is to switch off.	TUNING DOWN UP	Flashes TIMER EVERY
16	Press the ENTER/NEXT button.	ENTER/NEXT	Flashes TIMER EVERY TUNED FM 90.00 Lights up. (See NOTE)
17	Press the STANDBY button.	STANDBY	Flashes TIMER EVERY TUNED FM 90.00
18	Press the POWER button.	POWER ON/STANDBY	Flashes TIMER EVERY 10:15

- When the STANDBY button is pressed and the "Ⓞ" mark is lit, the timer will function at the same times each day.
- To switch off the timer, press the STANDBY button and turn off the "Ⓞ" mark.

NOTE:
 The timer standby mark "Ⓞ" will not light unless the current timer has been set. Should this be the case, set the current time, then press STANDBY the button.

NOTE:
 1) When there is an irregularity in the contents of the display or in the operation, unplug the power cord from the power outlet, then, while pressing down both the DOWN button of TUNING and the MEMORY button at the same time, plug the power cord into the power outlet again.
 All conditions will return to their initial settings and the display will appear normal. It will now be necessary to reset the presets, current time, and the timer setting time.
 2) To enable remote control operation of this system, the AC power is always supplied to the system. Even when the POWER button has been switched off, the display of the tuner will continue to be lit dimly.

Setting the Once Timer

(Preset the AM and FM stations in advance)

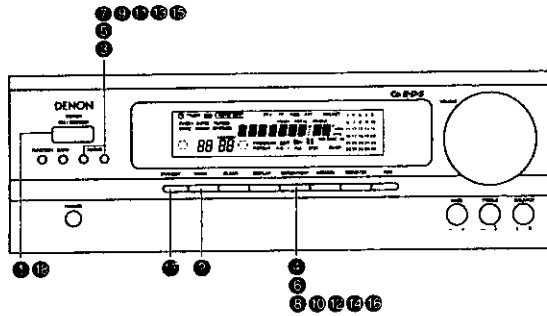

Example: Setting the timer to turn on at 12:35 and off at 12:56.
522 kHz AM is being received on preset number "2".
1611 kHz AM is set to preset number "15".

1	Press the POWER button.	POWER ON/STANDBY	TIMER	Flashes TIMER
2	Press the TIMER button.	TIMER	TIMER	Flashes TIMER
3	Press the DOWN button to display "ONCE".	TUNING DOWN UP	ONCE	Flashes TIMER
4	Press the ENTER/NEXT button.	ENTER/NEXT	FUNC	Flashes TIMER
5	Press the UP and DOWN buttons to display "TUNER".	TUNING DOWN UP	TUNER	Flashes TIMER
6	Press the ENTER/NEXT button.	ENTER/NEXT	AM 1611	Flashes TIMER
7	Press the UP and DOWN buttons to set the preset number 15.	TUNING DOWN UP	15	Flashes TIMER
8	Press the ENTER/NEXT button.	ENTER/NEXT	0:00	Flashes TIMER Lights up.
9	Use the UP and DOWN buttons to set the hour at which the timer is to switch on.	TUNING DOWN UP	12:00	Flashes TIMER
10	Press the ENTER/NEXT button.	ENTER/NEXT	12:00	Flashes TIMER

11	Use the UP and DOWN buttons to set the minutes at which the timer is to switch on.	TUNING DOWN UP	12:35	Flashes TIMER
12	Press the ENTER/NEXT button.	ENTER/NEXT	OFF	Flashes TIMER
13	Use the UP and DOWN buttons to set the hour at which the timer is to switch off.	TUNING DOWN UP	12:00	Flashes TIMER
14	Press the ENTER/NEXT button.	ENTER/NEXT	12:00	Flashes TIMER
15	Use the UP and DOWN buttons to set the minutes at which the timer is to switch off.	TUNING DOWN UP	12:56	Flashes TIMER
16	Press the ENTER/NEXT button.	ENTER/NEXT	AM 5 22	Flashes TIMER Lights up. (See NOTE)
17	Press the STANDBY button.	STANDBY	AM 5 22	Flashes TIMER Lights up. (See NOTE)
18	Press the POWER button.	POWER ON/STANDBY	10:15	Flashes TIMER

- When the STANDBY button is pressed and the "☉" mark is lit, the timer will function one time only.
- To switch off the timer, press the STANDBY button and turn off the "☉" mark.







NOTE:

The standby mark "☉" will not light unless the current timer has been set. Should this be the case, set the current time, then press the STANDBY button.



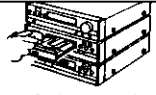
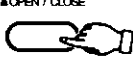

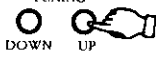

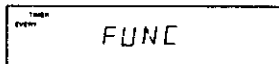
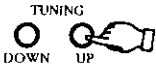
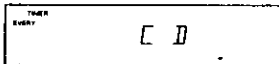
Ways to Use the Timer

Example 1: Waking up to the music of a compact disc.

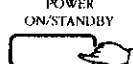
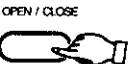
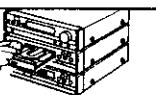
1 EVERYDAY TIMER

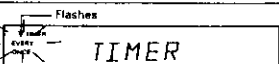

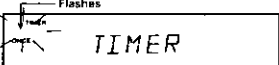

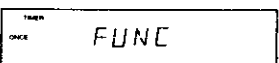
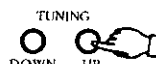
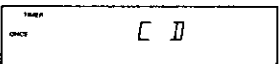

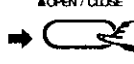

1	    <p>Press the receiver's POWER button to switch on the power. → Press the CD player's OPEN/CLOSE button to open the tray. → Set the compact disc in the tray. → Press the OPEN/CLOSE button again to close the tray.</p>	
2		
3		
4		
5		
6	Follow steps 8 to 18 under "Setting the Timer" on Page 12.	

2 ONCE TIMER

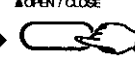

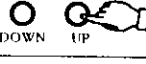
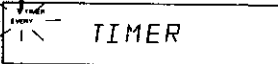

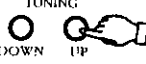



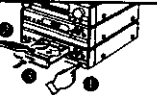

1	    <p>Press the receiver's POWER button to switch on the power. → Press the CD player's OPEN/CLOSE button to open the tray. → Set the compact disc in the tray. → Press the OPEN/CLOSE button again to close the tray.</p>	
2		
3		
4		
5		
6	Follow steps 8 to 18 under "Setting the Timer" on Page 13.	

Example 2: Waking up to the music of a cassette tape.

1 EVERYDAY TIMER

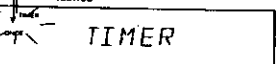
1	    <p>Press the receiver's POWER button to switch on the power. → Press the cassette deck's OPEN/CLOSE button to open the tray. → Load the cassette tape. → Press the OPEN/CLOSE button again to close the tray.</p>	
2		
3		
4		
5		
6	Follow steps 8 to 18 under "Setting the Timer" on Page 12.	

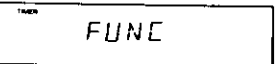
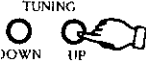
2 ONCE TIMER

1	    <p>Press the receiver's POWER button to switch on the power. → Press the cassette deck's OPEN/CLOSE button to open the tray. → Load the cassette tape. → Press the OPEN/CLOSE button again to close the tray.</p>	
2		
3		
4		
5		
6	Follow steps 8 to 18 under "Setting the Timer" on Page 13.	

Example 3: Unattended recording of radio broadcasts ("air checks")

1 EVERYDAY TIMER

1	<p>Press the receiver's POWER button to switch on the power. → Press the deck OPEN/CLOSE button to open the tray. → Load the cassette tape to which you will record. → Press the OPEN/CLOSE button again to close the tray.</p>
2	<p>Press the receiver's TIMER button.</p>
3	<p>Press the UP button to display "EVERY".</p>
4	<p>Press the ENTER/NEXT button.</p>
5	<p>Press the UP and DOWN buttons of the receiver to display "AIR CHECK".</p>
6	<p>Follow steps 6 to 18 under "Setting the Timer" on Page 12.</p>

2 ONCE TIMER

1	<p>Press the receiver's POWER button to switch on the power. → Press the deck 2 OPEN/CLOSE button to open the tray. → Load the cassette tape to which you will record. → Press the OPEN/CLOSE button again to close the tray.</p>
2	<p>Press the receiver's TIMER button.</p>
3	<p>Press the DOWN button to display "ONCE".</p>
4	<p>Press the ENTER/NEXT button.</p>
5	<p>Press the UP and DOWN buttons of the receiver to display "AIR CHECK".</p>
6	<p>Follow steps 6 to 18 under "Setting the Timer" on Page 13.</p>

- Timer recording starts in the direction indicated by the tape deck.
- Check that the tape direction and REV MODE switch settings are as desired.
- The section of leader tape at the beginning of the tape cannot be recorded. To avoid missing the beginning of the recording, forward the tape about 10 seconds.

Checking the Timer Settings

To check the timer settings, turn on the receiver's POWER button, press the TIMER button, select "EVERY" or "ONCE" with the AUTO TUNING UP button, then press the ENTER/NEXT button. The timer start mode, reception band, preset number, on time, and off time are displayed in order each time the ENTER/NEXT button is pressed. One more press returns the display to the reception frequency.

Changing the Timer Settings

When the timer setting operation is repeated, the previous settings are deleted and the new settings are set.

Deleting the Timer Settings

The timer settings can be cleared by pressing the TIMER button, select "EVERY" or "ONCE" with the TUNING UP button, then press the ENTER/NEXT button and then while "FUNC" is being displayed, pressing the CLEAR button.

Note about the Set Timer

If the set time of the timer is reached while the power is on, the timer settings will take over and there will be a switch to the function that has been set on the timer.

Cancelling the Timer

Press the STANDBY button and the "⏸" mark will go off.

Setting the Sleep Timer

(Use the remote control unit for these operations.)

Example: Setting the power to switch off in 50 minutes.

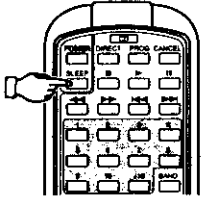
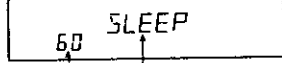
	Currently receiving 87.50 MHz, FM.	FM 87.50 MHz	
1			
	Press the remote control unit's SLEEP button.	"60" is displayed. "SLEEP" appears and flashes for 5 seconds.	
2	Press the SLEEP button again while "SLEEP" is flashing.	"50" is displayed, and the frequency display (87.50) reappears after 5 seconds.	The power is switched off after 50 minutes.

- If the sleep timer and regular timer settings overlap, the sleep timer is given priority.
- Do not press the STANDBY button after the power has been switched on with the timer. If this is done, the timer will not function properly.
- If the same time is set for the on time and off time, the power will not be switched on even when the "STANDBY" indicator is lit.
- If the timer is set for an AM or FM station and the on time of the timer is reached while listening to another station, the tuner switches to the station which was set with the timer.

Cancelling the Sleep Timer

- To cancel the timer while it is operating in the sleep mode, press the SLEEP button, and while "SLEEP" is flashing, press the CLEAR button on the receiver.
- Press the SLEEP button repeatedly until the power turns off. This cancels the sleep timer.

8 CASSETTE DECK

Before Recording and Playback

Auto Reverse

This deck is equipped with an auto reverse mechanism, so cassette tapes can be played and recorded on both sides or played continuously without having to turn them over.

Direction of tape travel

This deck has two play buttons, one for the forward direction (front side) and another for the reverse direction (back side). The side being played can be changed during playback by pressing the opposite play button.

Reverse mode

Set the reverse mode switch (REV MODE) as follows:

Single-side recording/playback mode ()

In this position, only the front side or the back side of the cassette tape is played or recorded. (The tape stops automatically when the end of that side is reached.)

Two-side recording/playback mode ()

In this position, when the end of the front side is reached, recording or playback automatically switches to the back side and continues from there. (The tape stops automatically when the end of the back side is reached.)

Continuous playback mode ()

In this position playback continues until the STOP button is pressed.

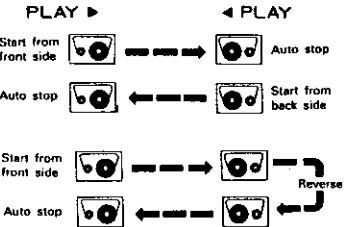
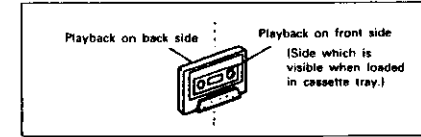

- * If you start playing or recording from the back side, the tape will stop automatically at the end of the back side.

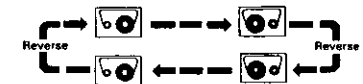

- * The reverse recording/playback mode () is set automatically during recording.

Storage Precautions

- Avoid storing in the following places:
 - Hot, humid places
 - Dusty places
 - Places exposed to direct sunlight
 - Near magnetic fields (TVs, speakers, etc.)
- Store the cassette tape in a case equipped with stoppers to keep the tape from coming slack.

Protecting Cassette Tapes From Being Erased Accidentally

- Cassette tapes are equipped with accidental erasure prevention tabs. To protect recorded tapes from being erased accidentally, use a screwdriver, etc., and break these tabs off.
- To record on a cassette tape whose accidental erasure prevention tabs have been broken off, place a piece of cellophane tape over the hole.

Cassette Tapes

Handling Precautions

- C-120 cassette tapes
Avoid using 120-minute cassette tapes, since they have extremely thin tape which tends to become wound onto the capstans or pinch rollers.
- Tape slack
If the tape is slack, it may become wound onto mechanism parts or otherwise damaged. Take up the slack with a pencil before loading the cassette.

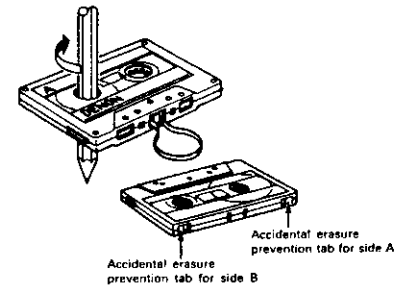

Before Operating

Loading and Unloading Cassette Tapes

• Loading

- 1 Press the OPEN/CLOSE button (▲) to open the cassette tray.
- 2 Set the tape in the cassette tray with the open side (on which the tape is exposed) facing away from you.
- 3 Press the OPEN/CLOSE button again to close the tray.

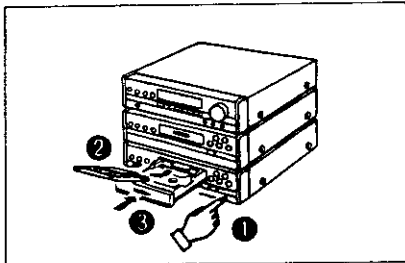

• Unloading

- 1 Press the STOP button (■).
- 2 Press the OPEN/CLOSE button (▲) to open the cassette tray.
- 3 Remove the cassette tape.

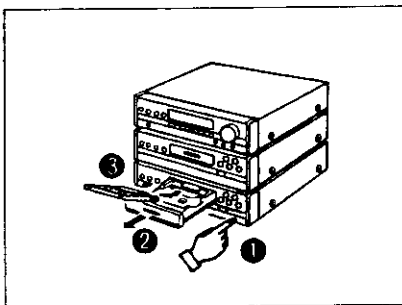

Check the following before recording or playing cassette tapes:

1. Is the head dirty? ...
The sound quality will be poor if the head is dirty. Refer to Page 23.
2. Are the accidental erasure prevention tabs broken off? ...
Recording is not possible if these tabs are broken off. Refer to Page 16.

NOTE:

- Load the cassette tape on an angle with the open side facing away from you. Loading it in the opposite direction can cause damage.
- Do not press the OPEN/CLOSE button during playback or recording. Always press the STOP button before pressing the OPEN/CLOSE button.

Auto Tape Selector Mechanism

This deck is equipped with an auto tape selector mechanism which uses the detection holes in the cassette halves to automatically set the recording bias and equalization best suited for that type of tape.

- Do not use ferrichrome tapes.
- Use metal tapes equipped with detection holes. (Use of the old type of metal tape without detection holes will result in the sound having an emphasized treble region.)

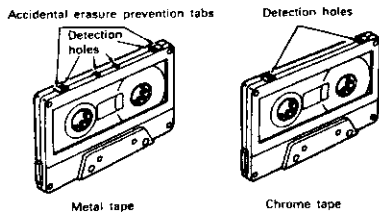

9 PLAYING CASSETTE TAPES

(Single Side Playback, Two-Side Playback, and Continuous Playback)

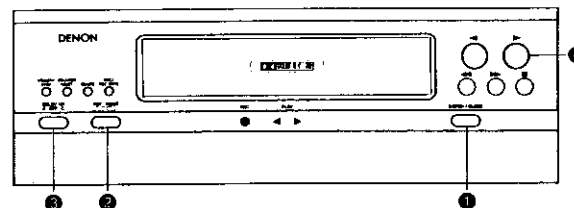

<p>1</p> <p>Press the POWER button of the receiver, then press the OPEN/CLOSE button and load a recorded tape into the tray. Refer to Page 17.</p>		<p>Loading the tape</p> <p>The tape can be loaded easily by inserting it at an angle.</p>
<p>2</p> <p>Set the REV MODE switch. Refer to Page 16.</p>		<p>Removing the tape</p> <p>The tape can be removed easily by lifting it out toward yourself at an angle.</p>
<p>3</p> <p>Set the DOLBY NR switch. Refer to Page 6 (CASSETTE DECK).</p>	<p>Set to B or C (as indicated on the tape) for tapes recorded with Dolby NR.</p>	
<p>4</p> <p>Press the play button (▶ or ◀).</p>		<p>Playback starts in the direction of the button pressed.</p> <p>Press the stop button (■) to stop the playback.</p>

Using the MS (Music Search) Function

- Use this function to move to the beginning of the following section or return to the beginning of the current selection.
 - 1 Press ▶ or ◀.
 - 2 Press ▶▶ or ◀◀.
- In the rewind direction, playback starts from the beginning of the selection which is currently playing, and in the fast-forward direction, playback starts from the beginning of the following selection.

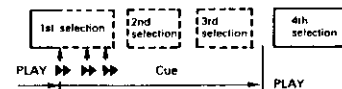
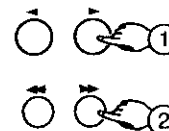

The tape skips by a number of selections equal to the number of times the ▶▶ or ◀◀ button is pressed.

■ Music search display

- During the music search operation, the number of selections to be skipped is indicated on the tape counter, and this number decreases each time a blank section between selections is detected (ex.: 3 → 2 → 1).
- When a previous selection is specified: P-03 → Number of selections to be skipped
← Lights when moving to previous selections
- When a subsequent selection is specified: P-05 → Number of selections to be skipped

10 RECORDING CASSETTE TAPES

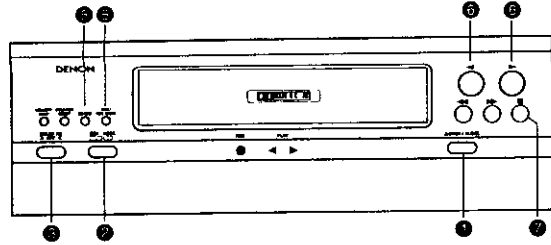

• The positions of the VOLUME and tone controls do not affect the sound being recorded.

1	<p>Press the OPEN/CLOSE button and load the tape to which you will record. Refer to Page 17.</p>						
2	<p>Set the REV MODE switch to or . Refer to Page 16.</p> <p style="text-align: center;">Single-side recording Two-side (reverse) recording.</p> <p style="text-align: center;">REV MODE </p>						
3	<p>Set the DOLBY NR switch. Refer to Page 6 .</p> <p style="text-align: center;">DOLBY NR B OFF C</p> <p style="text-align: center;">Set to B or C to record with Dolby NR.</p>						
4	<table border="1" style="width: 100%;"> <tr> <th style="width: 33%;">Recording from the radio</th> <th style="width: 33%;">Recording from a AUX/DAT</th> <th style="width: 33%;">Recording from a CD player</th> </tr> <tr> <td style="text-align: center;"> BAND Press the BAND selector button. Select the station you wish to record. (Refer to Page 9.) </td> <td style="text-align: center;"> FUNCTION Press the receiver's FUNCTION button and select AUX. Start playback on the DAT. </td> <td style="text-align: center;"> Set the disc in the CD player. (Refer to Page 18.) </td> </tr> </table>	Recording from the radio	Recording from a AUX/DAT	Recording from a CD player	 BAND Press the BAND selector button. Select the station you wish to record. (Refer to Page 9.)	 FUNCTION Press the receiver's FUNCTION button and select AUX. Start playback on the DAT.	 Set the disc in the CD player. (Refer to Page 18.)
Recording from the radio	Recording from a AUX/DAT	Recording from a CD player					
 BAND Press the BAND selector button. Select the station you wish to record. (Refer to Page 9.)	 FUNCTION Press the receiver's FUNCTION button and select AUX. Start playback on the DAT.	 Set the disc in the CD player. (Refer to Page 18.)					
5	<p>Press the REC/REC MUTE button. The REC (recording) indicator lights. (5) CD SRS</p>						
6	<p>Press the or button. (Recording starts)</p>						
7	<p>To stop recording, press the stop button. </p>						

11 PLAYING CDs

Compact Discs

- Press the OPEN/CLOSE button () once to open the disc tray, once again to close it.
- The disc tray can also be closed by pressing the play () button. When this is done, playback automatically starts from the first track on the disc (or if the tracks are programmed, the first programmed track).
- Load the disc with the label side facing up, being careful not to touch the disc surface.
- Load the disc with the disc tray open all the way.
- Set the disc securely in the tray guide at the center of the disc tray. To play an 8 cm disc, place the disc in the sunken part at the center of the disc tray.
- When the disc tray is closed, the disc turns automatically for several seconds, and the number of tracks and total playing time appear on the display.



Only discs with this mark can be played.

- For CDVs, only the audio part is played (the video part is not played).

When removing the disc from its case:

As shown in the diagram, grasp the disc along the edges, gently press down on the hole in the middle with a finger, and lift the disc. It should come out easily.



When setting the disc in the disc tray:

Always set the disc with the label side facing up. (Compact discs can only be played on one side). For 8 cm CDs, set the disc in the sunken part in the middle of the tray.

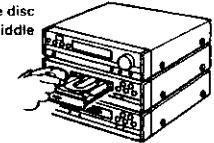

Disc	Remarks
CD	
CDV	Only the audio part is played.
CD single (8 cm)	

Handling the Disc Tray

Do not switch off the power or push or pull the disc tray when it is moving, since this may damage it.

If the cord of a set of headphones, etc., gets caught in the disc tray when it is closed, press the OPEN/CLOSE button () again.

- Never set objects other than CDs in the disc tray, as this can cause damage.

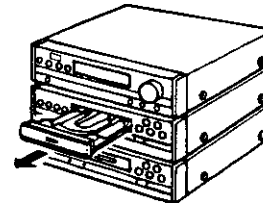

NOTE:

"NO DISC" is displayed on the display window when no disc is loaded, when the disc is loaded upside-down, or when the disc is not properly loaded. Also, " " may appear during playback of a CD if the disc is scratched or dirty. If this happens, the set will not operate when a normal operating button (other than the OPEN/CLOSE button) is pressed, so press the OPEN/CLOSE () button, remove the disc, clean it as necessary, then press the PLAY () button again.

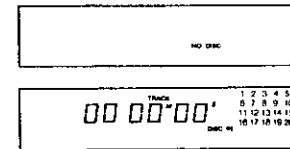

- When the CD SRS button is pressed, a 7-second blank portion is automatically created before recording starts.

Regular Play

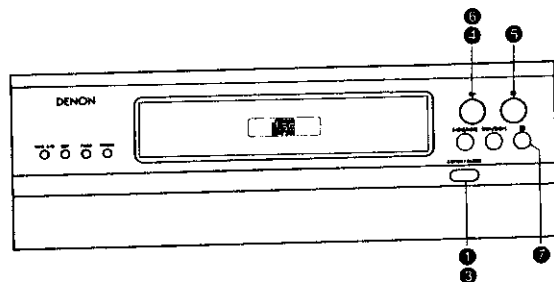

Example: Playing a CD with 15 tracks and a total playing time of 62 minutes 03 seconds, starting from track 1

1	Press the POWER button of the receiver, then press the OPEN/CLOSE button.	 The disc tray opens	
2	Set the CD in the disc tray. Refer to Page 18.		The display appears several seconds after the disc tray closes.
3	Press the OPEN/CLOSE button.	 The disc tray closes	
4	Press the PLAY button.	 CD play starts	

To stop play temporarily:

5	Press the PAUSE button.		"▶ PLAY" goes off and " PAUSE" appears. CD play is paused at the point the button is pressed.
---	-------------------------	--	---

To resume CD play:

6	Press the PLAY button.		" PAUSE" goes off and "▶ PLAY" appears. CD play resumes from the point the pause button was pressed.
---	------------------------	--	--

To stop CD play:

7	Press the STOP button.		
---	------------------------	--	--

NOTE:

• "00" is displayed on the track number section of the display for several seconds after the disc is set, while the data on the number of tracks, playing time, etc., is being read from the disc. After this, the number of tracks and total playing time appear.

Various CD Play Functions

(Insert the disc before performing the following operations.)

Playing Certain Tracks

Example: Playing the 8th track
Perform this operation from the remote control unit.

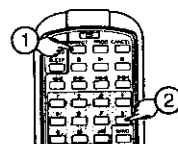

- Press the DIRECT button.
 - Press track button "8". "TRACK 8" appears on the display, and the 8th track begins playing.
- When the end of the track is reached, play continues on to the next track.

DIRECT SELECTION

- For track numbers of 11 and higher, for example 15, press [+10] and [5]. For track numbers of 20 and higher, for example 23, press [+10], [+10], and [3]. For track number 20, press [+10] and [10].

Playing 1 Track Repeatedly

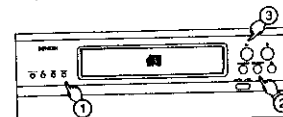

- Press the REPEAT button once.
- Press the [10] or [10] button, and select the desired track.
- Press the play button (▶) to start play.

1 TRACK REPEAT

- When the specified track finishes playing, the pickup returns to the beginning of that track and play is repeated.
- If the REPEAT button is pressed once during play, the track will be played repeatedly.
- If the REPEAT button is pressed once during programmed play, the track will be played repeatedly.
- If the REPEAT button is pressed once while the disc is stopped, the "REPEAT 1" indicator lights and the 1 track repeat play mode is set.

Playing All Tracks Repeatedly



- Press the REPEAT button twice.
- Press the play button (▶) to start play.

ALL TRACKS REPEAT

- When the last track finishes playing, the pickup returns to the first track of the disc and play is repeated.
- If the REPEAT button is pressed twice during play, the disc will be played repeatedly.
- If the REPEAT button is pressed twice during programmed play, the program will be played repeatedly.
- If the REPEAT button is pressed twice while the disc is stopped, the "REPEAT ALL" indicator lights and the all tracks repeat play mode is set.

Playing a Specific Section Repeatedly

SECTION REPEAT

Example: The CD has a total of 15 tracks

1st time	(1) Press the REPEAT button during CD play.		"REPEAT 1" lights up, and only that track is played repeatedly, and that track number lights on the music calendar. * With a 1-track repeat of track 31 or higher, "TRACK No." flashes.
	(2) Press the REPEAT button before CD play.		"REPEAT 1" lights up, and the total number of tracks lights, and then (1) the first track is repeated by pressing the play button (▶) when play is started by direct selection from the remote control or with the [10] or [10] button, only those selected tracks are played repeatedly.
2nd time	Press the REPEAT button before CD play or during CD play.	 	"REPEAT ALL" lights up, and the track numbers contained on the disc light up on the music calendar, and all tracks are played repeatedly.
3rd time	Press the REPEAT button during CD play.	 	"REPEAT A-" lights up. If nothing else is done, all tracks are played repeatedly.
4th time	Press the REPEAT button during CD play.	 	"REPEAT A-B" lights up. The A-B section is played repeatedly.

Pressing the REPEAT button once again returns the player to regular CD play.

● **Playing Certain Tracks in any Desired Order**
 (Perform this operation from the remote control unit.)

PROGRAMMED SELECTION

Example: Programming track 3 to play first, track 18 to play second, on a CD with 18 tracks and a total playing time of 82 minutes, 3 seconds

Setting and Playing the Program

1	Press the PROGRAM button.		
2	Set track 3 to play first.		<p>After 2 seconds The display when track 3 is set to play first Time of first track: 8 minutes, 00 seconds</p>
3	Set track 18 to play second.		<p>After 2 seconds The display when track 18 is set to play second Total time of tracks 1 and 2: 16 minutes, 05 seconds</p>
4	Press the play button.		<p>The tracks start playing in the programmed order.</p>

- The numbers of the programmed tracks go off once the tracks are played.
- The time display will read "— M — S" if a track number of 31 or higher is set in the program.
- When a program is set during CD play after a direct selection, the track currently playing is set as the first track in the program.
- Up to 30 tracks of your choice from among track numbers 1 through 99 can be programmed with this CD player.
- If you attempt to set a track number that is greater than the number of tracks on the disc, that track number will not be displayed when the buttons are pressed.
- Programming is also possible when the disc tray is open. In this case, track numbers greater than the number of tracks on the disc can be programmed, but these are ignored when the disc is played.
- There is a silent interval of 4 seconds between tracks. This is has been designed to create a blank section of 4 seconds between selections when recording programmed tracks onto tape.
- The entire program is cleared when the disc tray is opened (by pressing the button).
- If you make a mistake when programming tracks, press the CANCEL button and program again. (Each press of the CANCEL button cancels the last track.)
- An A-B section repeat is not possible during programmed play.
- Other operations possible during programmed play:
 The quick search, pause, skip monitor, and other operations can be used during programmed play. To move to the beginning of the previous track with the quick search operation, press once, then once again while the time display reads " 0 0 0 . ". To move to the beginning of the following track, press once, regardless of the time display.
- Perform programming and canceling in the stop mode.
- Programming is also possible in the same way using the PROG button on the CD player. (In this case, use the button to select the track number, the PROG button as the memory button. In other words, first press the PROG button, next press the button to select the track number, then press the PROG button again to set the track in the memory. For the second track as well, press the button then the PROG button.)

● **Moving to the Next Track During CD Play**
 QUICK SEARCH

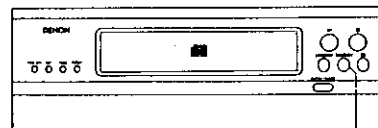

- ① Press the auto search forward button ().
- Each press of the auto search forward button () moves the pickup to the beginning of following tracks.

● **Moving Back to the Beginning of the Current Track During CD Play**
 QUICK SEARCH

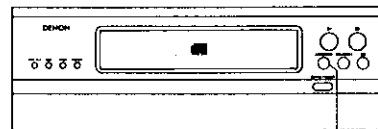

- ① Press the auto search backward button ().
- Each press of the auto search backward button () during the search operation moves the pickup to the beginning of previous tracks.

● **Searching for Tracks While Listening to the Sound**
 SKIP MONITOR

- Use this to skip through a disc listening to the sound at high speed.
- This function is convenient when searching for a certain section within a long track.
- Use the skip monitor function to find the desired position, then release the search button to start regular playback from there.

① **Forward skip monitor**

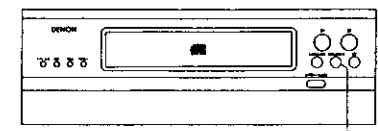

- The track number and elapsed playing time of the track being skipped through are indicated on the display.
- If the end of the last track on the disc is reached while pressing the search button, (JJ) appears on the display and the skip monitor operation stops. To resume CD play, press the search backward button () until (JJ) switches to the track number, then perform a different operation.

- ① During CD play, press and hold in the forward search button () to skip forward while listening to the sound.

② **Backward skip monitor**

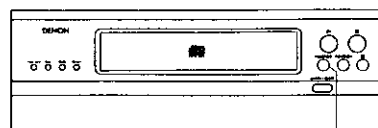

- The track number and elapsed playing time of the track being skipped through are indicated on the display.
- If the beginning of the first track on the disc is reached while pressing the search button, (LL) appears on the display and the skip monitor operation stops. To resume CD play, press the search forward button () until (LL) switches to the track number, then perform a different operation.

- ① During CD play, press and hold in the backward search button () to skip backward while listening to the sound.

If the forward or backward skip button is pressed during programmed CD play and released at a track which has not been programmed, the next programmed track will be played once that track has been played to the end.

Edited Recording onto Sides A and B of a Tape (EDIT)

Editing is possible with CDs containing up to 30 tracks.

Before starting the edited recording operation, load the cassette tape to which you will record into deck with side A facing up.

The leader tape is automatically taken up before recording starts.

(Set the REV MODE switch to the  position.)

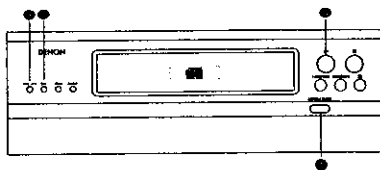

Automatic Edited Recording

RECORDING IN THE SAME ORDER AS ON THE DISC

Example: Recording a disc with 18 tracks and a total playing time of 56 minutes onto a C-60 cassette tape

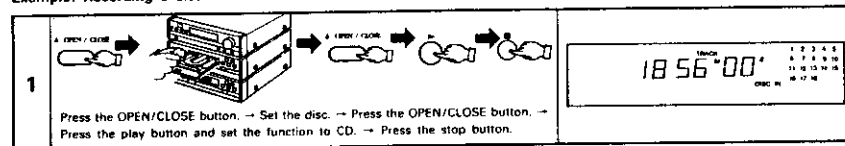





NOTE:

- With edited recording, side B of the tape will be recorded automatically even when the REV MODE switch of the deck is set to the  position.
 - During edited recording, only the following buttons will function: the stop button of the CD or the OPEN/CLOSE button, and the stop button of the deck.
 - When using a recorded tape for edited recording, the tape should be erased before use, since when the tape is longer than the set time, an unrecorded section of side B will remain after the tape stops.
- When a tape which has been recorded with this system is played back, there will be 4-second blank portions between tracks (for making it easy to reach the beginning of a track). This will differ from the actual silent portions between the tracks on the disc, and so there will be some error in the actual remaining time of the tape and the displayed time.

Press the EDIT button to set the tape length. Press the EDIT button four times when using a 60-minute (C 60) tape. (The tape length is to total time of sides A and B.)



The display changes as follows each time the EDIT button is pressed. (When the tape time has already been set, the display will change in order starting at that time each time the EDIT button is pressed.)

The desired recording time can be set when this is displayed.

Example: For a 36-minute tape, use the  or  button to set 36. To set the tape length using the remote control unit, use the number buttons. For example, in the case of a 30-minute tape, press  twice and press .

If you make a mistake, press the EDIT button to display "C-00", then start over again.

Setting the desired recording time (Method 2)

Select a tape length close to the desired time, then make a fine adjustment using the  or  button. For example, to set 51 minutes, select C-50, then press the  button once to set C-51.

EDIT flashes for 2 seconds

2 minutes 40 seconds extra on side A

Tracks for side A light up. Tracks for side B flash. (Tracks 1 through 9 are recorded on side A.) (Tracks 10 through 18 are recorded on side B.)

3

A/B button is pressed. (Use this to check the extra time on side B.)

The display changes between sides A and B each time the TAPE

Tracks for side A flash. 1 minute 20 seconds extra on side B.

Tracks for side B light up.

4

Press the play button.

Track number

Elapsed time





- Note that in some cases, even if the tape is longer than the total playing time on the disc, it may not be possible to record all the tracks onto the tape, since they are divided onto sides A and B. In such cases, the OVER indicator flashes.



Programmed Edited Recording

RECORDING CERTAIN TRACKS IN ANY DESIRED ORDER

- 1 Follow the instructions under "PROGRAMMED SELECTION" on Page 20 to program the tracks.
- 2 Perform steps 2 through 4 under the aforementioned "Automatic Edited Recording".

Programmed CD Play Using the Search Buttons (

Pressing the PROGRAM button of the remote control unit will light up the "PROGRAM" indicator. When the disc is stopped, programming can be done with the search buttons ( ) on the CD player or with the search buttons ( ) on the remote control unit.

- Select the tracks with the search buttons, then press the PROGRAM button to program them.
- The search buttons ( ) can be used to change the track numbers continuously.
- After the track numbers have been selected with the search buttons, if the play button is pressed to start CD play before the PROGRAM button is pressed, the last track of the program set up to this point will be played. In this case, the tracks selected with the search buttons will not be programmed.

12 REMOTE CONTROL UNIT

Cautions on Use

1. The D-90 is supplied with a remote control unit (RC-170) for system control.
2. Replace the batteries with new ones when the transmission distance possible with the remote control unit shortens.
3. For longer battery life, remove the batteries when not using the remote control unit for long periods.
4. When replacing batteries, use two new batteries. Never use an old battery with a new one.
5. Do not use two different types of batteries.
6. Do not heat batteries or take them apart.
7. Be careful that the remote control sensor is not exposed to direct sunlight or strong light from lighting fixtures.
8. The remote control sensor is located on the receiver. Point the remote control unit at the sensor, then press the buttons for the desired operation.
9. Operate the remote control unit within the range illustrated in the diagram.

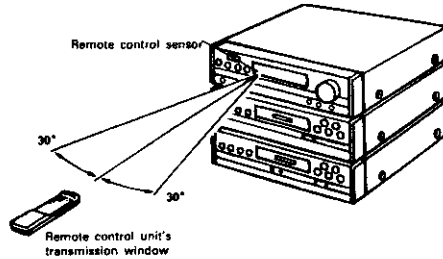

10. Do not press buttons on the remote control unit and on the main unit at the same time. Doing so will lead to a malfunction.
11. If  appears on the receiver display due to incident light even though the remote control unit has not been operated, it is best to move the set or place it in a different direction. Even if this happens, it will not cause a malfunction with remote control unit.
12. When adjusting the volume continuously with the remote control unit, the volume adjustment will stop if the remote control unit is moved away from the remote control sensor. Should this happen, press the button again to continue changing the volume.

Inserting the Batteries

- ① Open the battery case lid on the back of the remote control unit.

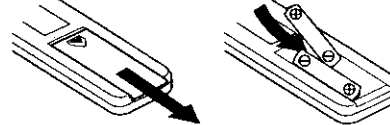

- ② Insert the two batteries (R6/AA) in the proper direction.

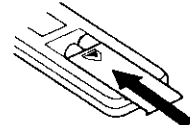

- ③ Set the battery case lid back in place.

 appears at the upper left corner of the receiver display when a signal is received.

• The remote control unit can be used at a distance of about 7 meters from the remote control sensor, but this distance will be shorter if there are obstacles in the way or if the remote control is operated from an angle.

Button Names and Functions

POWER

Press this to switch on the power for the entire system or set the system to standby.

SLEEP

Press this to set the sleep timer.

Number buttons

After pressing TUNER, these buttons call up the preset stations. When used with CD play, after pressing DIRECT or PROGRAM, these buttons specify the tracks to be played.

Operating the Cassette Decks

Stop button (■)
Press this to stop the tape deck.

Forward play button (▶)
Press this to play back or record in the forward direction.

Reverse play button (◀)
Press this to play back or record in the reverse direction.

• **REC button (recording button)**
To set the recording mode when in the stop mode, press this button, then press either the "▶" or the "◀" button. When pressed during the recording or recording pause mode, a blank section of approximately 5 seconds is created on the tape, after which the deck is set to the recording pause mode.

Rewind button (◀◀)
Press this to rewind the tape.

Fast-forward button (▶▶)
Press this to fast-forward the tape.

FUNCTION (Input switching) button

Switches the function TUNER, TAPE, CD, AUX and PHONO.

TUNER

- **CT (Clock Time) button**
When the FM band has been set, a single press of this button will cause the clock display to appear for 2 seconds. Pressing the button again while the clock is displayed, enables the clock to be matched to the time of the RDS broadcast time service.
- Some stations which provide RDS broadcasts do not broadcast CT signals, in which case the time display cannot be corrected by pressing the CT button.

SDB (Super Dynamic Bass)

Press this button for more powerful bass sound. Press again to return to the original setting.

CD Play

DIRECT button
Press for direct track selection of CD player.

PROGRAM button
Press for programmed selection of CD player.

CANCEL button
Press once during programming to cancel the last track programmed.

Operating the CD Player

Pause button (||)
Press to temporarily stop CD play. Press the play button ▶ to resume play.

Stop button (■)
Press to stop CD play.

Play button (▶)
Press to start CD play.

Manual search backward button (◀◀)
Manual search forward button (▶▶)
Press these to quickly move backward or forward.

Backward skip monitor button (◀◀◀)
Press during CD play to go back to the beginning of that track. Press the button again within 0.5 seconds to go back to the beginning of the previous track.

Forward skip monitor button (▶▶▶)
Press during CD play to go forward to the beginning of the next track. Press the button again to go forward to the beginning of the track two tracks ahead.

VOLUME

Adjusts the volume. Press V to lower the volume, and A to raise it.

Press this button to listen to the preset stations.

• **BAND button**
Use this to select the FM or AM band. When this button and number button is pressed in the standby condition, the power is automatically switched on.

• **TUNING buttons**
Use these to tune in FM or AM stations.

• **PRESET buttons**
Use these to select preset stations. When this button is pressed in the standby condition, the power is automatically switched on.

• **RDS (Radio Data System) button**
This button is used for the RDS search, PTY search and TP search operations.

13 IMPORTANT INFORMATION

• Head Cleaning

After the cassette deck has been used for a while, powder from the tapes and dirt adhere to the head and lower the sound quality.

Use a head cleaning cassette tape to clean.

NOTE:

Some of the cleaning sets on the market have a strong polishing effect which can damage the head.

• Disc Cleaning

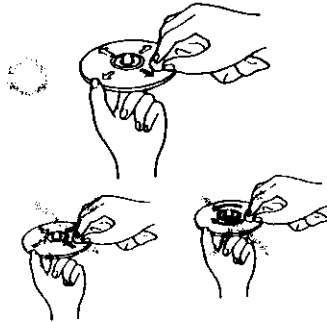

Never use the following to clean discs:

- Solvents such as benzene or alcohol
- Cleaners containing abrasives
- Record sprays or cleaners
- Anti-static products

• Head Demagnetizing

The heads become magnetized after the deck has been used over a long period of time or if the heads are exposed to a magnetic field. This results in noise and reduced treble. In addition, there may be a reduction of the treble range of recorded tapes as well as noise produced on these tapes. When the heads become magnetized, use one of the cassette tape head demagnetizers (erasers) available on the market to demagnetize the heads.

- For details, read the operating instructions of the demagnetizer.

Dust, fingerprints, or spittle on the disc can cause noise or skipping.

If the disc is dirty or if the player does not work properly, clean the disc as follows:

- Hold the disc as shown in the diagram, with the signal surface facing up (and the labelled side facing down).
- Using a soft cloth, wipe the disc gently from the inside straight towards the edges (as shown by the arrows).

- Do not wipe from the edges towards the center, or around the disc as you would wipe records.
- Do not use hard cloths or rub the disc forcefully, since the signal surface is susceptible to scratches.

14 SPECIFICATIONS

■ Receiver (UDRA-77)

• Tuner

Reception Frequency Range:

FM: 87.50 MHz to 108.00 MHz

AM: 522 kHz to 1611 kHz

FM: 1.5 μ V, 75 ohms (SN ratio 30 dB)

AM: 20 μ V (SN ratio 20 dB)

Receiving Sensitivity:

40 dB (1 kHz)

FM Stereo Separation:

• Amplifier

Rated Output Power:

30 W + 30 W (40 Hz to 20 kHz, 6 ohm)

Jacks:

3.5 mm headphone jack

Bass Adjustment:

100 Hz \pm 8 dB

Treble Adjustment:

10 kHz \pm 8 dB

Super Dynamic Bass:

80 Hz + 8 dB

Jacks:

PHONO: Input jacks

AUX/DAT: Input jacks, recording output jacks

PROCESSOR: Processor input/output jacks

Dimensions (max.):

273 (W) \times 97 (H) \times 323 (D) mm (10-48/64" \times 3-13/16" \times 12-23/32")

Weight:

5.6 kg (12 lbs 5 oz)

Power Supply:

AC 230 V, 50 Hz

Power Consumption:

95 W

■ CD Player (UCD-77)

Wow and Flutter:

Below measurable limits (\pm 0.001% W, Peak)

Sampling Frequency:

44.1 kHz

Light Source:

Semiconductor

Dimensions (max.):

273 (W) \times 97 (H) \times 295 (D) mm (10-48/64" \times 3-13/16" \times 11-39/64")

Weight:

2.6 kg (5 lbs 12 oz)

■ Cassette Deck (UDR-77)

Type:

Horizontal 4-track, 2-channel auto reverse stereo cassette deck

Heads:

1 hard permalloy recording/playback head

and 1 double-gap ferrite erase head

Tape Speed:

4.75 cm/s

Noise Reduction Circuits:

Dolby B and C NR

Usable Tapes:

Normal, chrome and metal tapes

Dimensions (max.):

273 (W) \times 97 (H) \times 295 (D) mm (10-48/64" \times 3-13/16" \times 11-39/64")

Weight:

2.9 kg (6 lbs 60 oz)

■ Remote Control Unit (RC-800)

Type:

Infrared pulse

Number of Buttons:

40

Dimensions (max.):

54.5 (W) \times 183 (H) \times 18.5 (D) mm (2-3/16" \times 7-9/16" \times 7/9")

Weight:

100 g (Approx. 4.6 oz) (including batteries)

* Maximum dimensions include controls, jacks, and covers.

(W) = width, (H) = height, (D) = depth

• For improvement purposes, specifications and functions are subject to change without advanced notice.

15 TROUBLESHOOTING

1. Check that the connections are proper.
2. Check that you are operating the system according to the instructions in the manual.

Check the following table if the system does not seem to be working properly.

If the problem is not solved after checking these points carefully, the system may be malfunctioning. Switch off the power and contact your store of purchase.

	Symptom	Cause	Measures	Page
Common	Power does not come on when POWER button pressed.	● Power cord not plugged into outlet.	● Plug cord into outlet properly.	5
	No sound produced from speakers.	● VOLUME control set to minimum	● Turn VOLUME control clockwise (↻).	6
		● Headphones are plugged in.	● Disconnect headphones	6
		● Speaker cables not connected to speaker terminals.	● Connect speaker cables properly.	5
		● The Relay is affected by clicking noise at intervals.	● Short-circuit with connection cord near speaker terminal. Check connection cord again.	5
	Treble not produced Orientation of sound field not clear.	● Speaker polarities (+ and -) not matched.	● Connect speaker cables properly.	5
	Source other than the desired one is heard.	● Function selector button not set properly	● Set to desired function	6
Deck	Cannot record when REC/REC MUTE button pressed.	● No cassette tape loaded.	● Load tape	17
		● Accidental erasure prevention tabs of cassette broken off	● Apply cellophane tape over holes	16
	Sound is interrupted during playback and recording, or treble sound is low.	● Head dirty.	● Clean.	23
		● Tape stretched.	● Replace tape.	-
	Wow (fluctuation) is heavy during playback and recording.	● Capstans and pinch rollers dirty.	● Clean.	23
Buzzing noise heard during playback.	● Noise from TV. ● (Some TVs produce noise.)	● Separate TV from system. ● Turn off TV.	- -	
Receiver	Hissing noise heard during FM reception.	● Antenna not pointed in proper direction ● Signals weak.	● Change direction of antenna. ● Install outdoor antenna.	4 4
	Hissing or scratchy noise heard during AM reception.	● Noise from TV, etc., or interference from other stations.	● Turn off TV. ● Change position of loop antenna ● Install outdoor antenna.	- - 4
	Hum noise heard during AM reception.	● Signals coming over power cord are modulated by power source frequency.	● Plug in cord in opposite direction ● Install outdoor antenna	5 4
CD Player	Disc loaded but total number of tracks not displayed	● Disc loaded upside-down	● Reload disc.	18
		● Disc dirty.	● Clean disc.	23
		● Non-standard disc loaded.	● Replace with standard disc	18
	Operation not performed when buttons pressed, or playback stops in middle of track.	● Disc loaded upside-down	● Reload disc.	18
		● Foreign object in disc holder ● Disc dirty. ● Disc scratched.	● Remove disc and remove foreign object. ● Clean disc. ● Replace with non-scratched disc	18 23 -
Sound skips.	● Dust, fingerprints, or spittle on disc. ● Disc scratched. ● Player set in shaky, unstable place.	● Clean disc. ● Replace with non-scratched disc ● Set player in stable place.	23 - -	
Buzzing noise mixed in with CD sound.	● Signals coming over power cord are modulated by power source frequency.	● Plug in cord in opposite direction	5	

Normal operation may not be possible if there is dirt or other substances on the surface of the internal objective lens or sensor.
These parts must be cleaned periodically depending on the place of installation.
For details, contact your store of purchase.

Avoid using ultrasonic humidifiers nearby.
If ultrasonic humidifiers are used nearby, the calcium, etc., included in the water may be scattered into the air, causing white dust to accumulate on the surface of the objective lens or sensor, resulting in improper operation.

Dew (Condensation) Phenomenon

Dew (water droplets) may form on the lens of the internal optical system or on the disc, or on the rotating parts of the tape deck in situations such as the following:

- Soon after a heater is put on.
- When the set is placed in a steamy or damp room.
- When the set is moved from a cold place to a warm room.

When Condensation Forms

The signals of the disc may not be read and this product will not operate properly. To remove the condensation, take out the disc and switch on the power. The condensation will evaporate within 1 hour and the set will operate normally.

This system consists of precision components using microprocessors. Avoid using it in places where there is much external noise. If used in such places, the system may not operate properly, but this is not a problem with the system. If the system does not operate properly, try performing the desired operation again.

RECEIVER SECTION

DISASSEMBLY PROCEDURES

(Follow these procedures in reverse order to reassemble.)

1. Removing the top cover and front panel

- ① Remove the six screws which fasten the top cover.
- ② Remove the two screws of the bottom side which fasten the front panel.

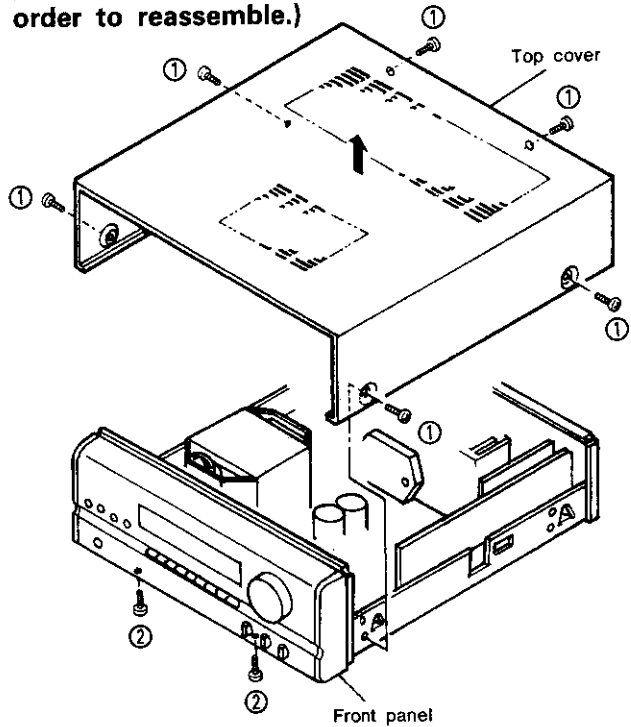

- ③ Remove the two screws which fasten the side plate.
- ④ While disengaging in the direction of the arrow the tabs of the side plate and the holes of the main chassis (with a flat-bladed screwdriver). Use your fingers to push out the hook of the inner panel from the side plate in the direction of the arrow. Using the same method for the left side, remove the side plate.
- ⑤ Remove the front panel in the direction of the arrow.

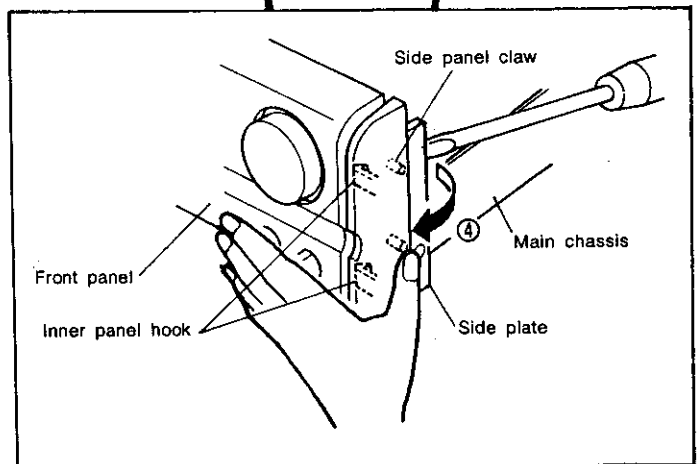
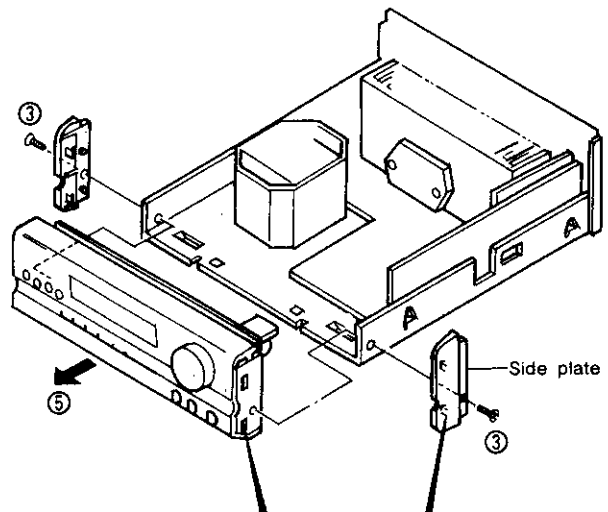

RECEIVER SECTION

2. Removal of the Various Units

Headphone Unit (KU-9332-3)

- ① Remove the screw securing the headphone unit.

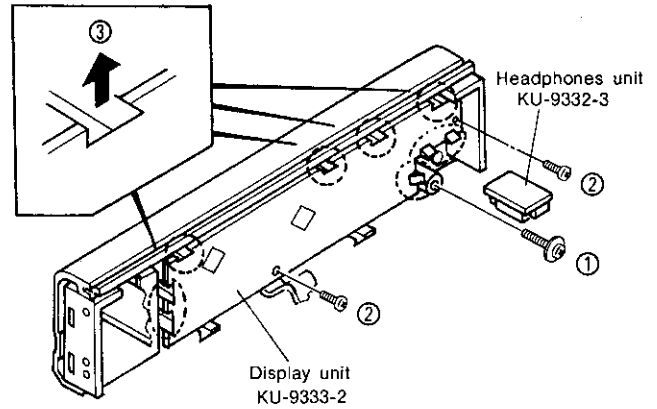

Display Unit (KU-9333-2)

- ② Remove the two screws securing the display unit.
- ③ Move the catch in the direction of the arrow and remove the display unit.

Volume Unit (KU-9332-3)

- ④ Remove the volume knob assembly and three tone knobs, then remove the nut securing the volume unit.

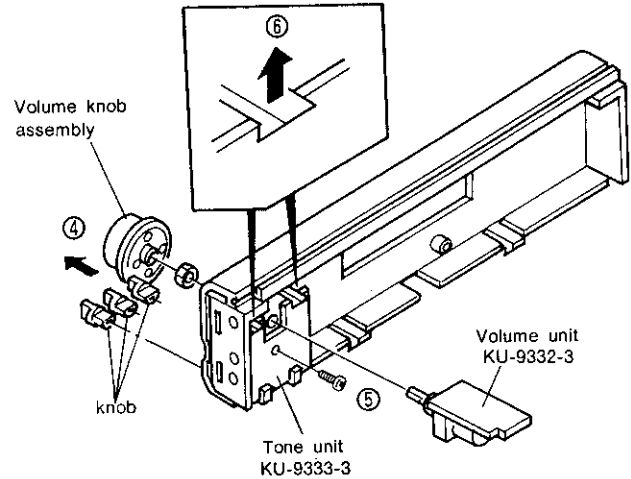

Tone Unit (KU-9333-3)

- ⑤ Remove the screw securing the tone unit.
- ⑥ Detach the inner panel hook's catch in the direction of the arrow.

RECEIVER SECTION

Tuner Unit (KU-9333-1)

- ⑦ Remove the three screws securing the tuner unit.

PREAMP Unit (KU-9332-2)

- ⑧ Remove the screw securing the preamp unit.

AC IN Unit (KU-9332-4)

- ⑨ Remove the two screws securing the AC in unit.

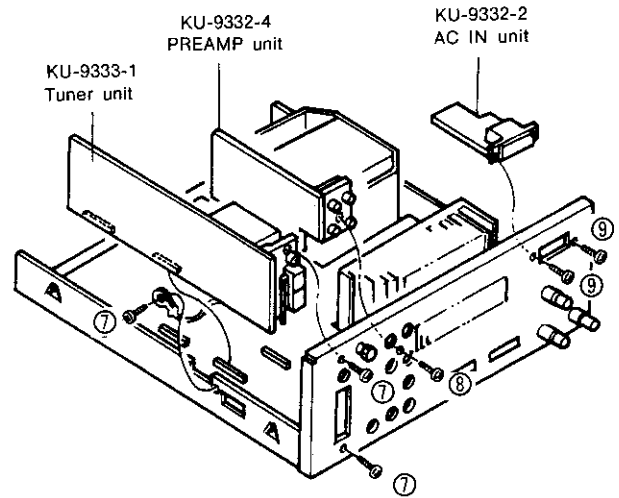

Main Unit (KU-9332-1)

- ⑩ Remove the three screws securing the heat sink.
- ⑪ Remove the five screws securing the rear panel.

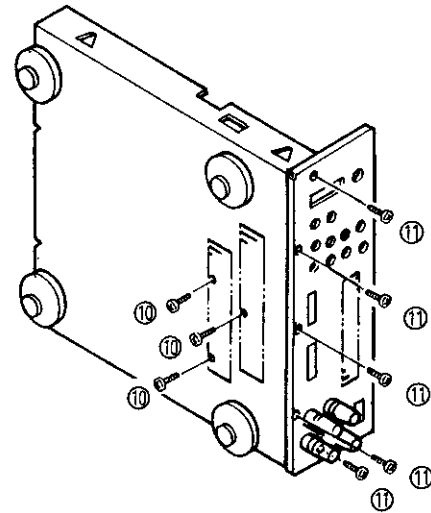

- ⑫ Remove the five screws securing the main unit.

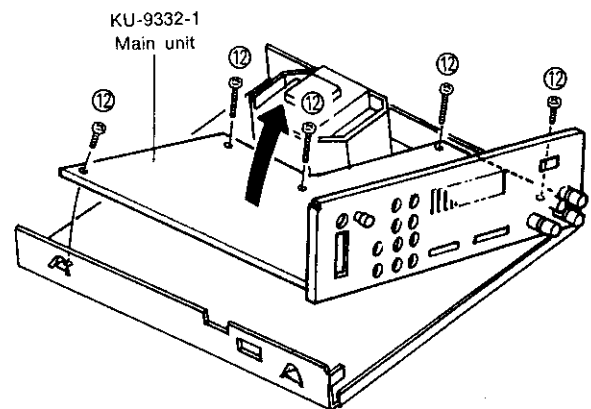

RECEIVER SECTION
● TUNER SECTION

BLOCK DIAGRAM

1

2

3

4

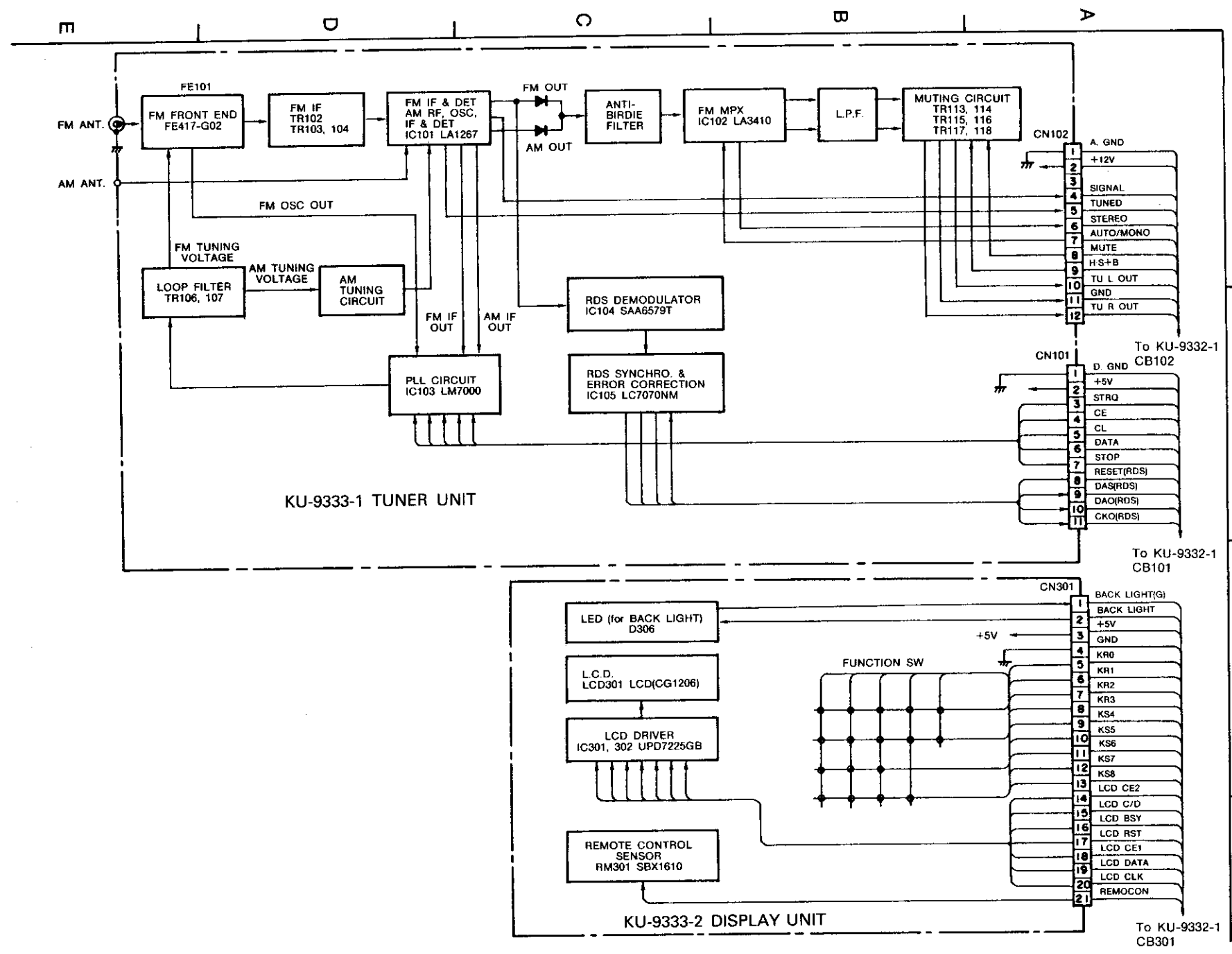

1 2 3 4 5 6 7 8

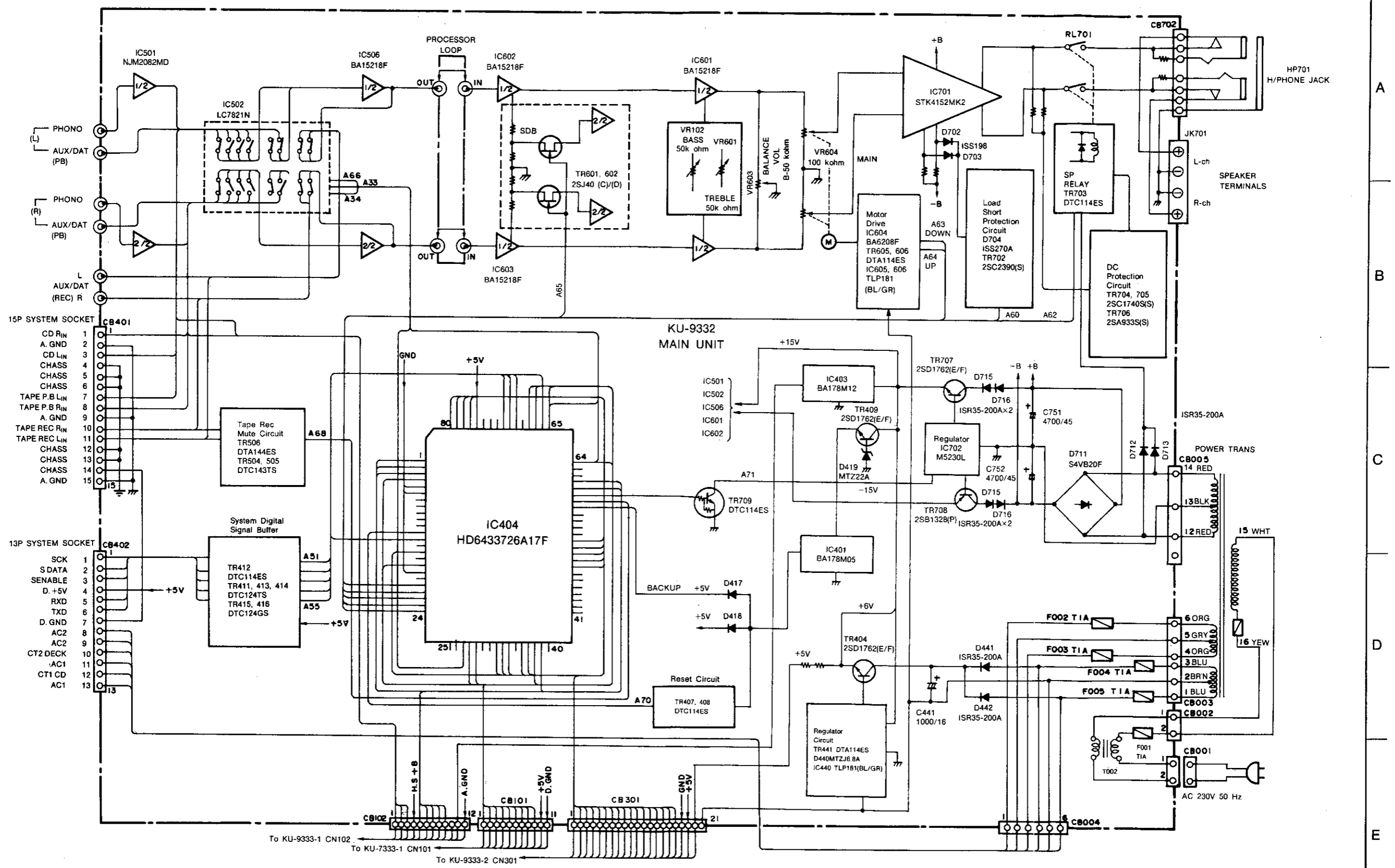

RECEIVER SECTION

LEVEL DIAGRAM

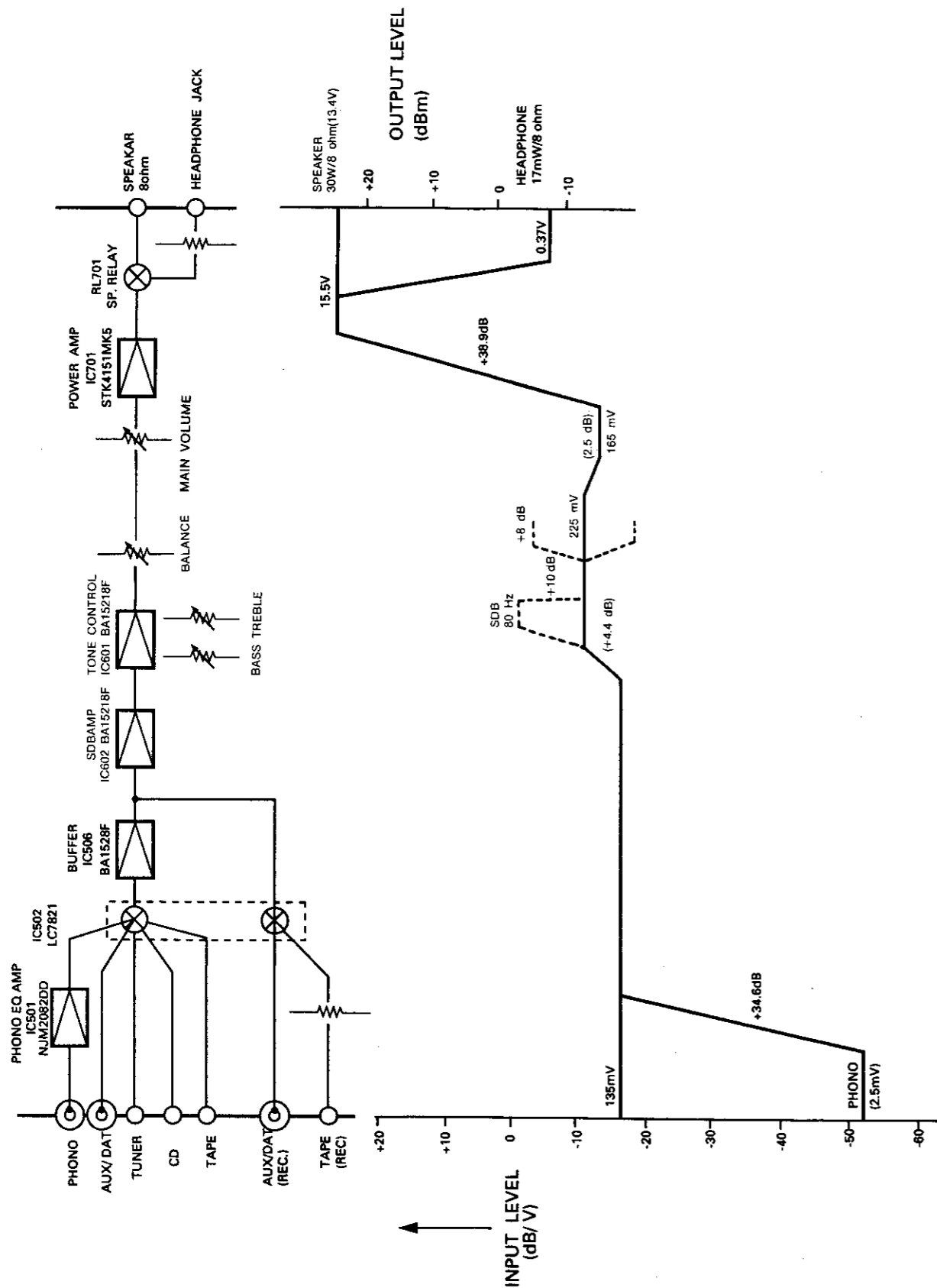

ADJUSTMENTS

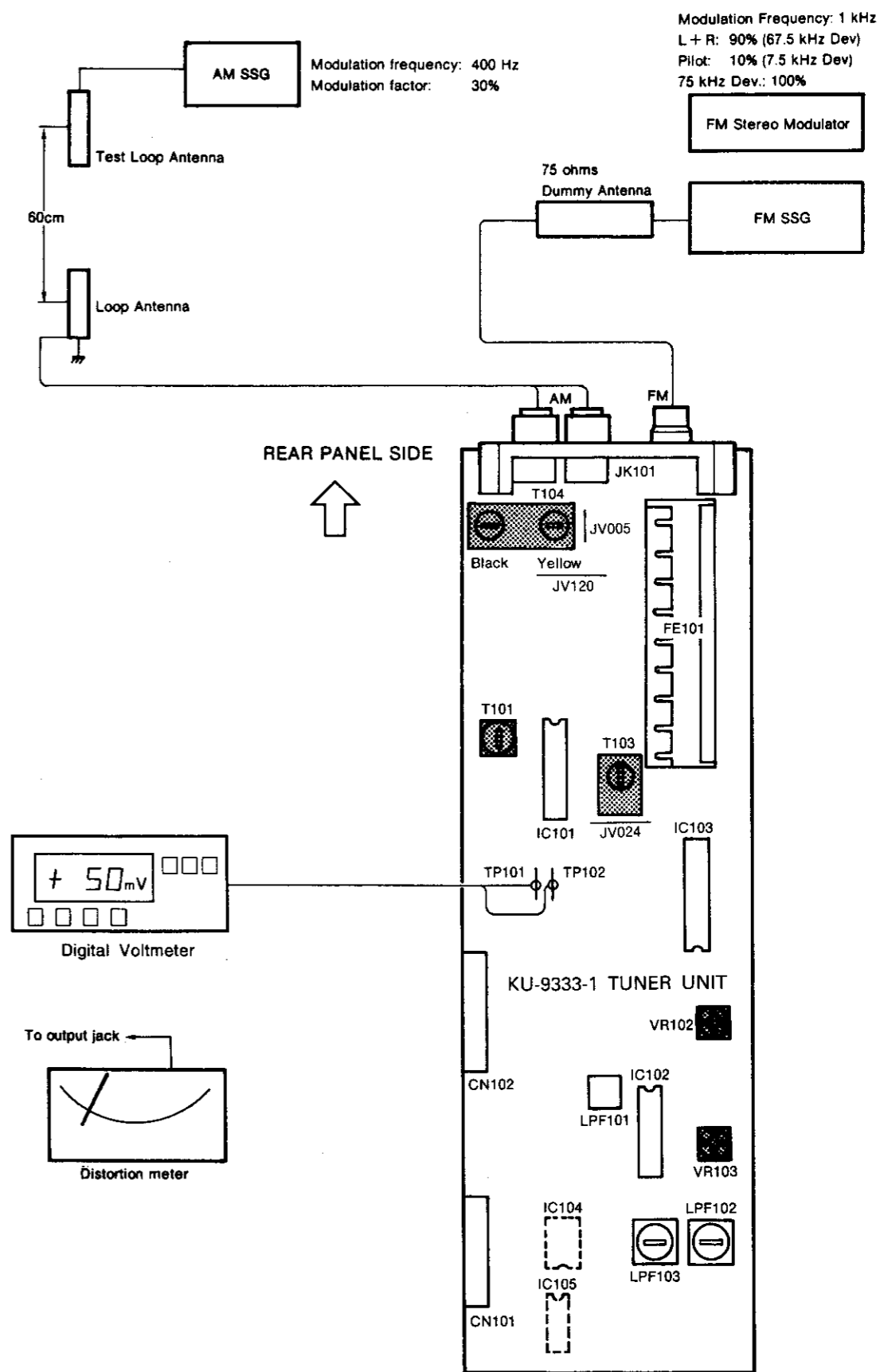

RECEIVER SECTION

1. FM adjustment (BAND button: FM, MONO/AUTO button: AUTO, RF ATT button: OFF)

Step	Adjustment item	Tuning point (channel setting)	Input					Output		Adjustment location	Setting value	Notes
			Measuring Instrument	Frequency	Input level	Modulation	Connection location	Measuring instrument	Connection location			
1	FM DC balance	98.00MHz	FM S.G.	98.00MHz	50dB μ	1kHz 75kHz DEV	FM antenna terminal	Digital volt meter	TP101 TP102	T101	0 \pm 50mV	Perform with monaural modulation signal
2	Muting level	98.00MHz	FM S.G.	98.00MHz	17dB μ	1kHz 75kHz DEV	FM antenna terminal	Check for the lighting of TUNED	Output jack	VR102	Input level 17dB μ \pm 4dB	(Level at which TUNED lights up) Level at which the output is provided Turn VR102 fully clockwise and adjust with VR102. It is not possible to adjust with VR102.
3	Stereo separation	-	FM stereo modulator FM S.G.	-	50dB μ	1kHz L or R: 67.5kHz DEV Pilot; 7.5kHz DEV	-	VTVM Oscilloscope	-	VR103	Minimum R.ch. Output	Perform with L.ch. Input of FM stereo modulator

2. AM adjustment (BAND button: AM)

Note: The AM IFT and MW ANT./OSC. coil are adjusted individually and normally do not require adjustment.

1	IF	Clear frequency (without a broadcast)	AM IF sweep	990kHz	Level at which AGC is not applied	-	AM antenna terminal	Oscilloscope	⊕ IC101 Pin 10 ⊖ JV024	T103	Waveform maximum and symmetry	
2	Band edge	522kHz	-	-	-	-	-	Digital voltmeter	⊕ JV120 ⊖ JV005	T104 Black	1.2V \pm 0.2V	
		1611kHz	-	-	-	-	-	-	-	-	Approx. 7.5V	No place to adjust
3	Tracking	603kHz	AM S.G.	603kHz	Level at which ACG is not applied	400Hz 30%	Loop antenna	VTVM	Output terminal	T104 Yellow	Maximum output	

KU-9333-1 TUNER UNIT (Component Side)

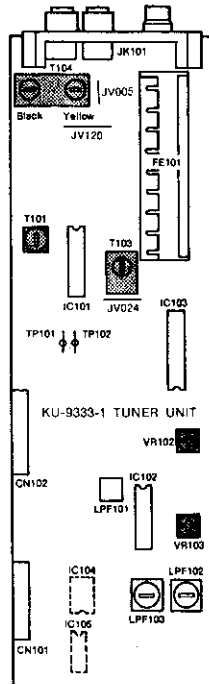

RECEIVER SECTION

Front End

Part No.: 216 0079 005

No.	Name	No.	Name
1	ANT	5	Vt
2	GND	6	+B
3	GND	7	IF OUT
4	GND	8	OSC OUT

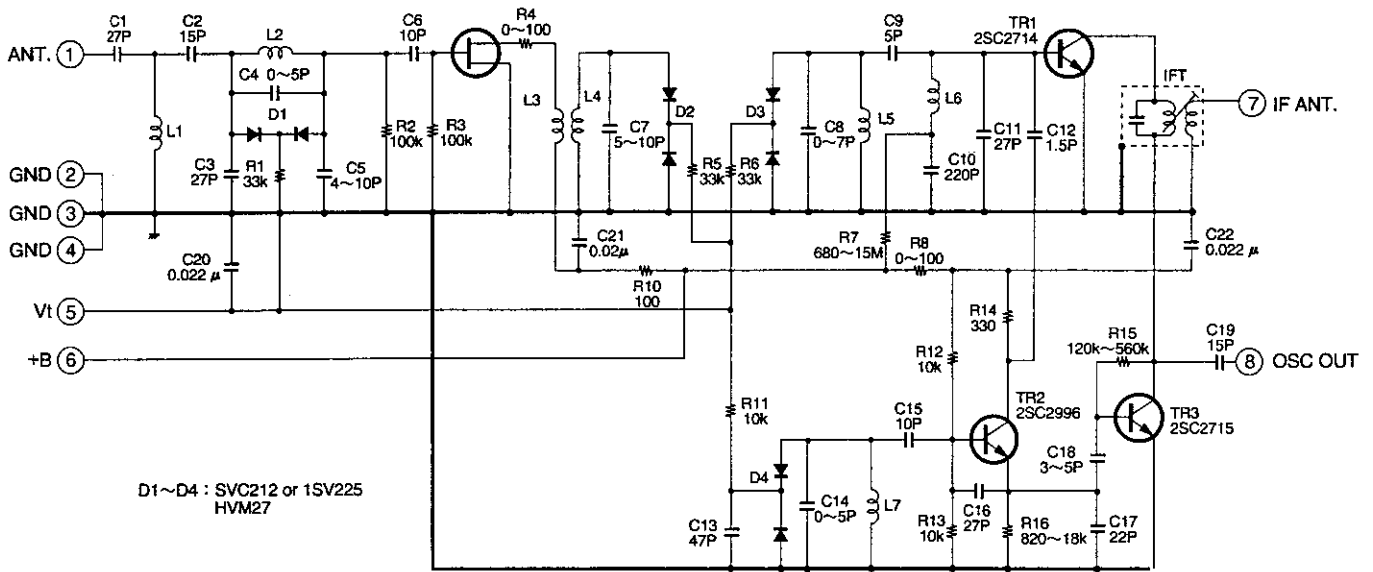
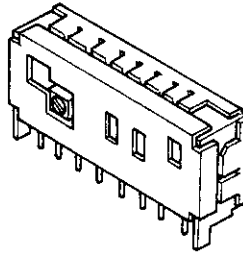

D1~D4 : SVC212 or 1SV225
HVM27

NOTES

1. TERMINAL NUMBER REFFER TO OVERALL APPEARANCE.
2. RECEIVING FREQUENCY. 87.5~108 MHz.
3. INPUT IMPEDANDE. 75 OHM.
4. OUTPUT IMPEDANCE. 300 OHM.
5. SUPPLY VOLTAGE. +B 12 V.
6. TUNING VOLTAGE. Vt 1.2 min~9.0 max V.

RECEIVER SECTION

SEMICONDUCTORS

• IC's

LM7000 (IC103)

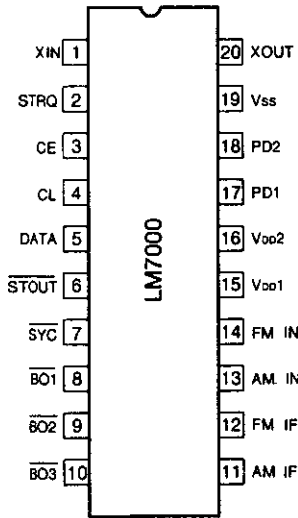
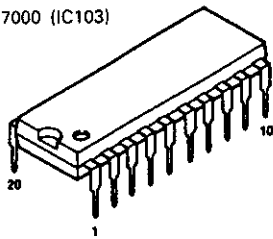

Pin Description

- SYC : Clock (400 kHz) for the controller
- XIN, XOUT : X'tal oscillator (7.2 MHz) with built-in feedback resistor
- FM IN, AM IN : Local oscillator signal input
- CE, CL, DATA : Data input
- BO1, BO2, BO3 : Band data output. BO1 can be set as the time base output (8 Hz).
- STRQ : IF counter request input
- STOUT : Auto research stop signal output
- V_{DD1}, V_{DD2}, V_{SS} : Power supply (V_{DD2} is a back-up power supply)
- AM IF, FM IF : IF signal input
- PD1, PD2 : Charge pump output

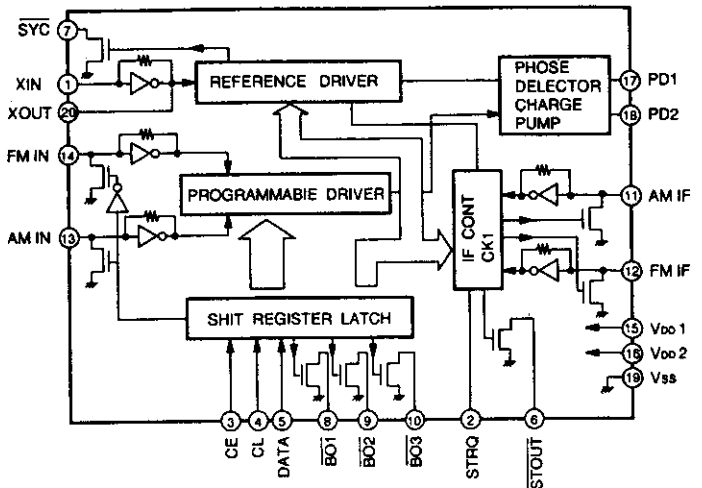

LA1267 (IC101)

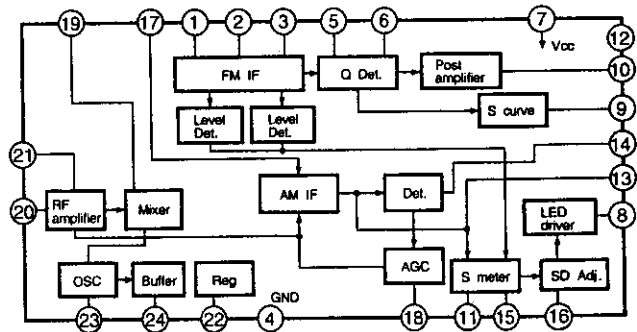
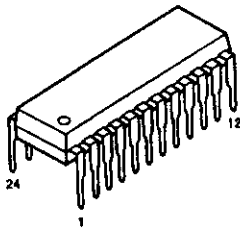

BA178M06 (IC401) ... +6V
BS178M12 (IC403) ... +12V

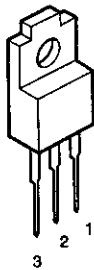

- 1 : Output
- 2 : GND
- 3 : Input

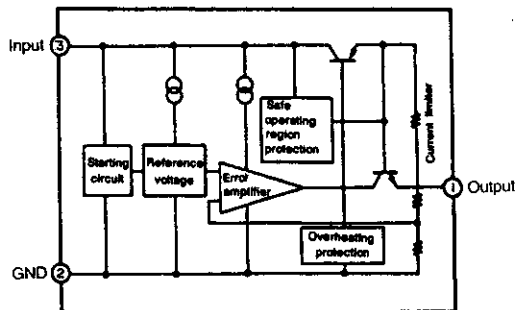

RECEIVER SECTION

SAA6579T (IC104)

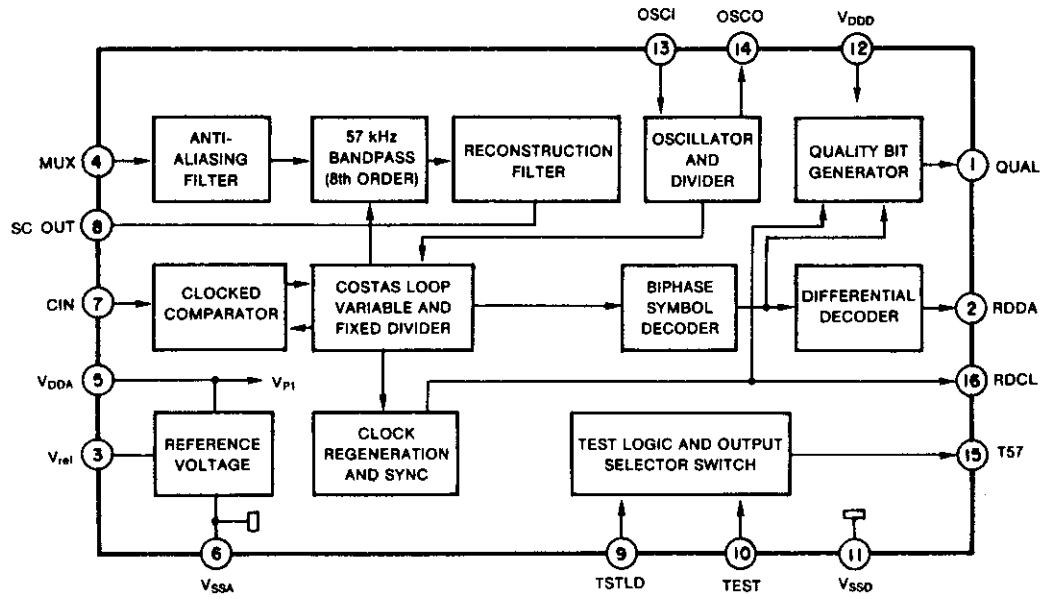
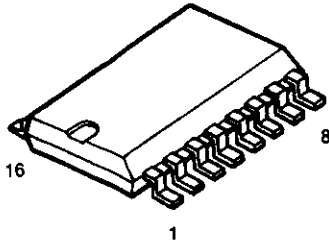

Block diagram and application circuit.

Pin Description

SYMBOL	PIN	DESCRIPTION
QUAL	1	quality indication output
RDDA	2	RDS data output
Vref	3	reference voltage output (0.5 V _{DDA})
MUX	4	multiplex signal input
V _{DDA}	5	+5 V supply voltage for analog part
V _{SSA}	6	ground for analog part (0 V)
CIN	7	subcarrier input to comparator
SCOUT	8	subcarrier output of reconstruction filter
TSTLD	9	test control
TEST	10	test enable
V _{SSD}	11	ground for digital part (0 V)
V _{DD}	12	+5 V supply voltage for digital part
OSCl	13	oscillator input
OSCO	14	oscillator output
T57	15	57 kHz clock signal output
RDCL	16	RDS clock output

Pin configuration

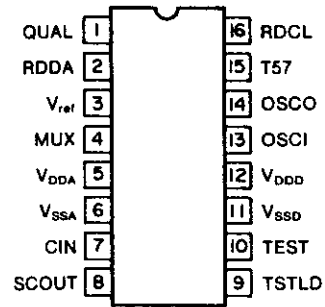

LA3410 (IC102)

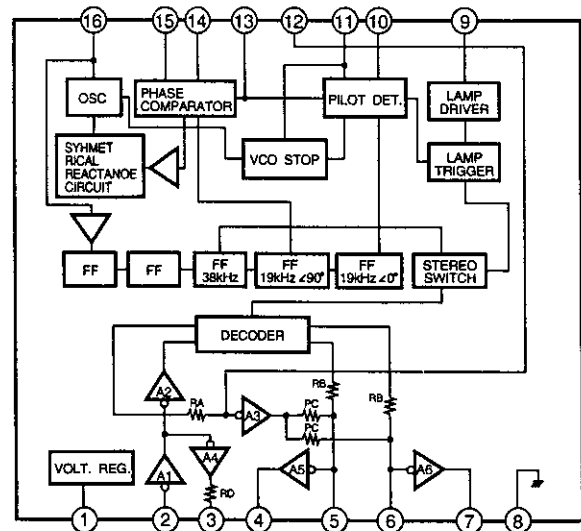
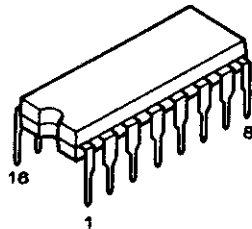

RECEIVER SECTION

STK4152II (IC351)

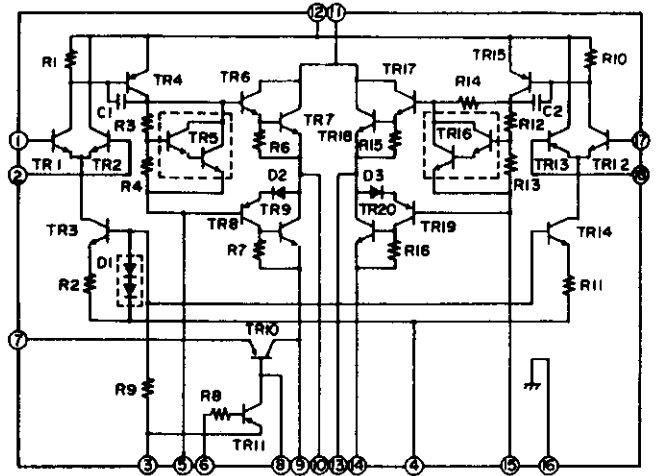
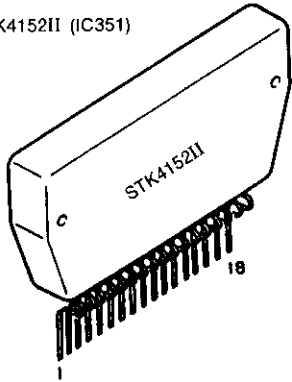

LC7821 (IC502)

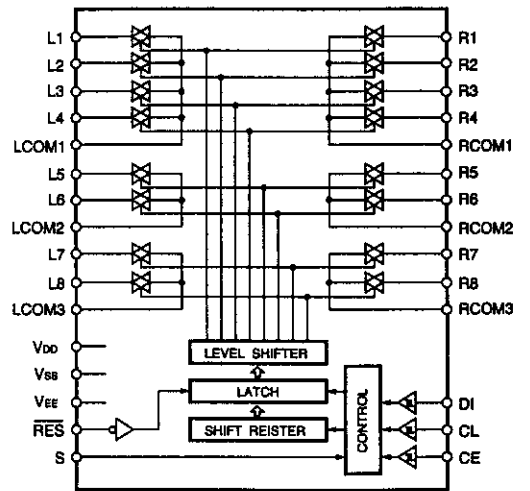
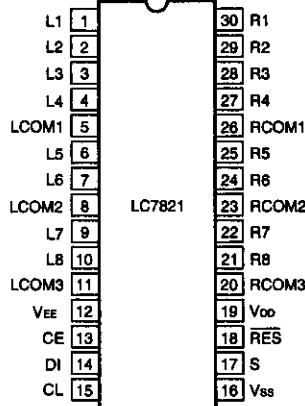
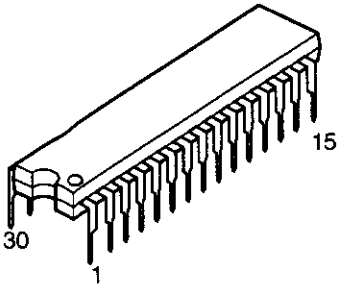

BA15218F (IC506, 601, 602, 603)
NJM2062MD (IC501)
M5230L (IC702)

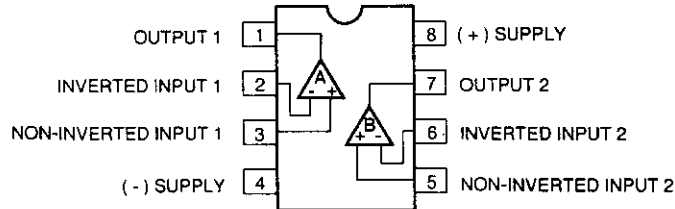
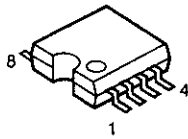

M5230L (IC702)

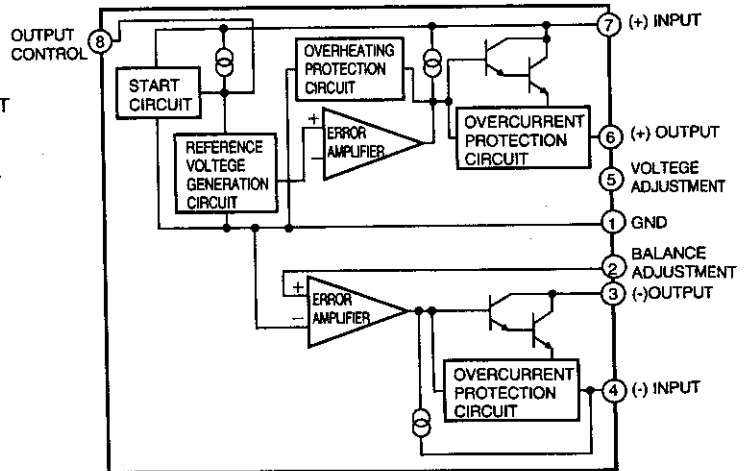
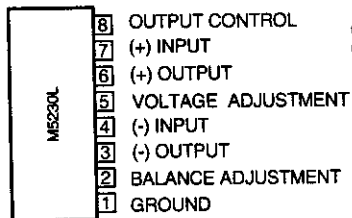
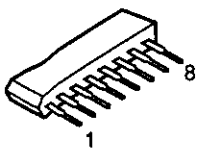

RECEIVER SECTION

LC7070NM (IC105)

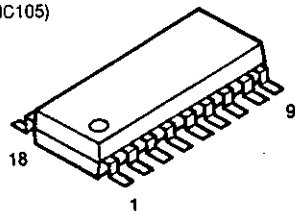

Pin Arrangement

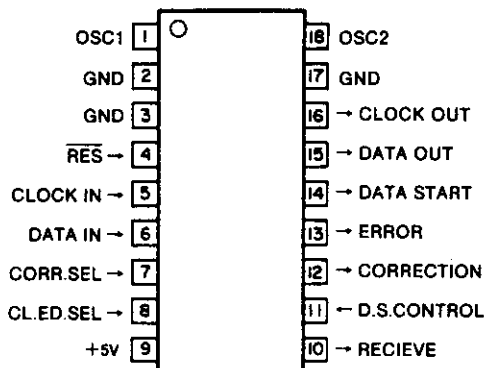

● Pin Description

Symbol	Pin No.	I/O	Function/Details	At Time of Reset
OSC1 OSC2	1 18	Input Output	· 4 MHz ceramic oscillator connection.	
CLOCK IN	5	Input	· RDS (LA2231) demodulation clock input.	"H" output
DATA IN	6	Input	· RDS (LA2231) demodulation data input.	"H" output
CORR. SEL	7	Input	· Error correction on/off selection input. · Sets the IC to correct errors in the RDS demodulation data or to output the data without correction. When input is 0 : No corrections are made When input is 1 : Corrections are executed	"H" output
CL. ED. SEL	8	Input	· Serial data clock polarity selection input. When input is 0 : Serial data output is enabled at the rise of the output clock. (Serial data output changes at the fall of the output clock.) When input is 1 : Serial data output is enabled at the fall of the output clock. (Serial data output changes at the rise of the output clock.) NOTE: Set at the time of RES input.	"H" output
D.S. CONTROL	11	Input	· Block data start signal control input. When input is 0 : Data start signal is output for all blocks. When input is 1 : Data start signal is output for only the second block.	"H" output
RECEIVE	10 (NC)	Output	· Output during RDS data reception. · After the completion of sync detection, there is a low-level, output while the serial data is being output. There is a high-level output at other times. · Open drain output.	"H" output
CORRECTION	12 (NC)	Output	· Output with or without error correction. · There is a low-level output when the output data of the serial data output have been corrected or when correction is not possible. There is a high-level output when correction has not been applied. · Open drain output.	"H" output
ERROR	13 (NC)	Output	· Presence of error output. · There is a low-level output when the output data of the serial data output has an error and correction is not possible. There is a high-level output when there is no error or when the error has been corrected. · Open drain output.	"H" output
DATA START	14	Output	· Block data start signal of the serial data output. Open drain output: LC7070N and LC7070NM Output with pull-up resistor: LC7071NM	"H" output

RECEIVER SECTION

Symbol	Pin No.	I/O	Function/Details	At Time of Reset
DATA OUT	15	Output	· Data output of the serial data output. Open drain output: LC7070N and LC77070NM Output with pull-up resistor: LC7071NM	"H" output
CLOCK OUT	16	Output	· Clock output of the serial data output. Open drain output: LC7070N and LC77070NM Output with pull-up resistor: LC7071NM	"H" output
RES	4	Input	· System reset input. · Reset and restart is accomplished by inputting the low level for 4 or more clock cycles.	

Structure of the RDS Data Processing System

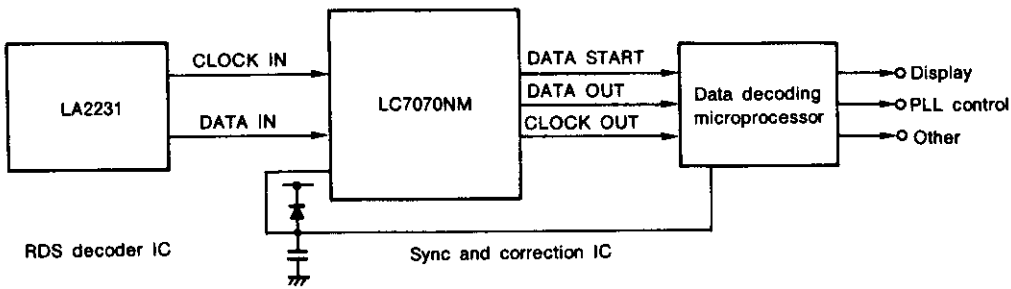

Serial Data Output Timing Chart

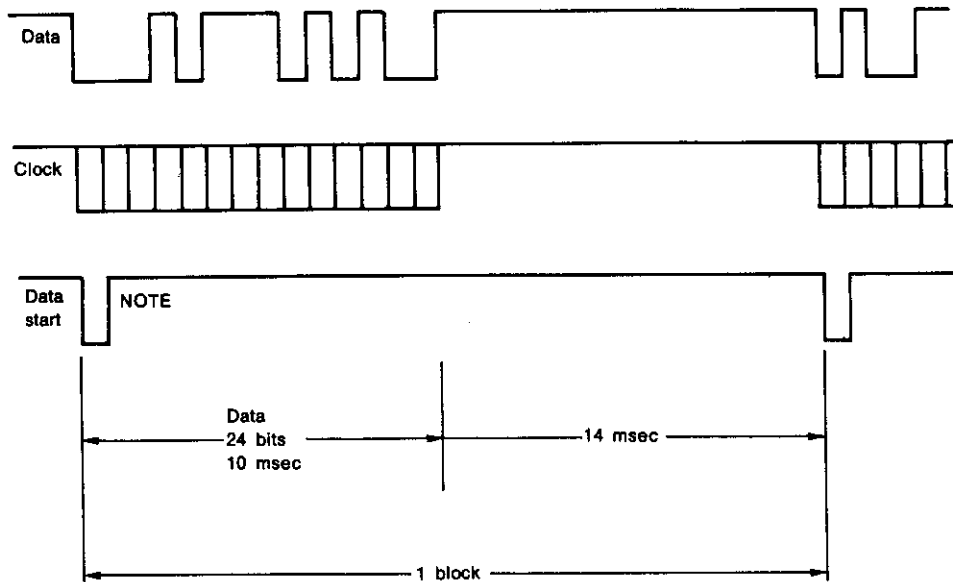

NOTE: Using the D.S. CONTROL input, only the second block among the entire 4 blocks of RDS data can be switched between the data start output and the total blocks' data start output.

RECEIVER SECTION

BA6208F (IN: IC604)

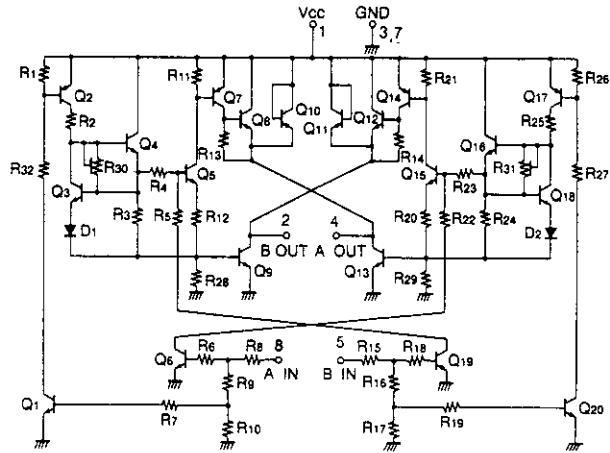
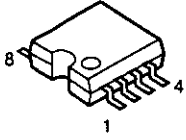

μPD 7225GB-3B7 (IC301, 302)

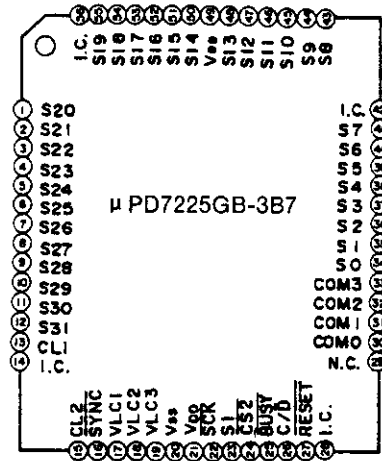
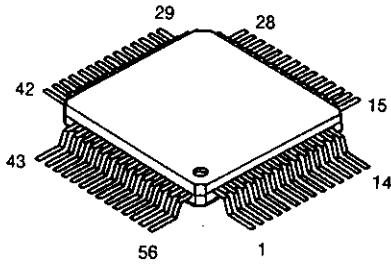

BLOCK DIAGRAM

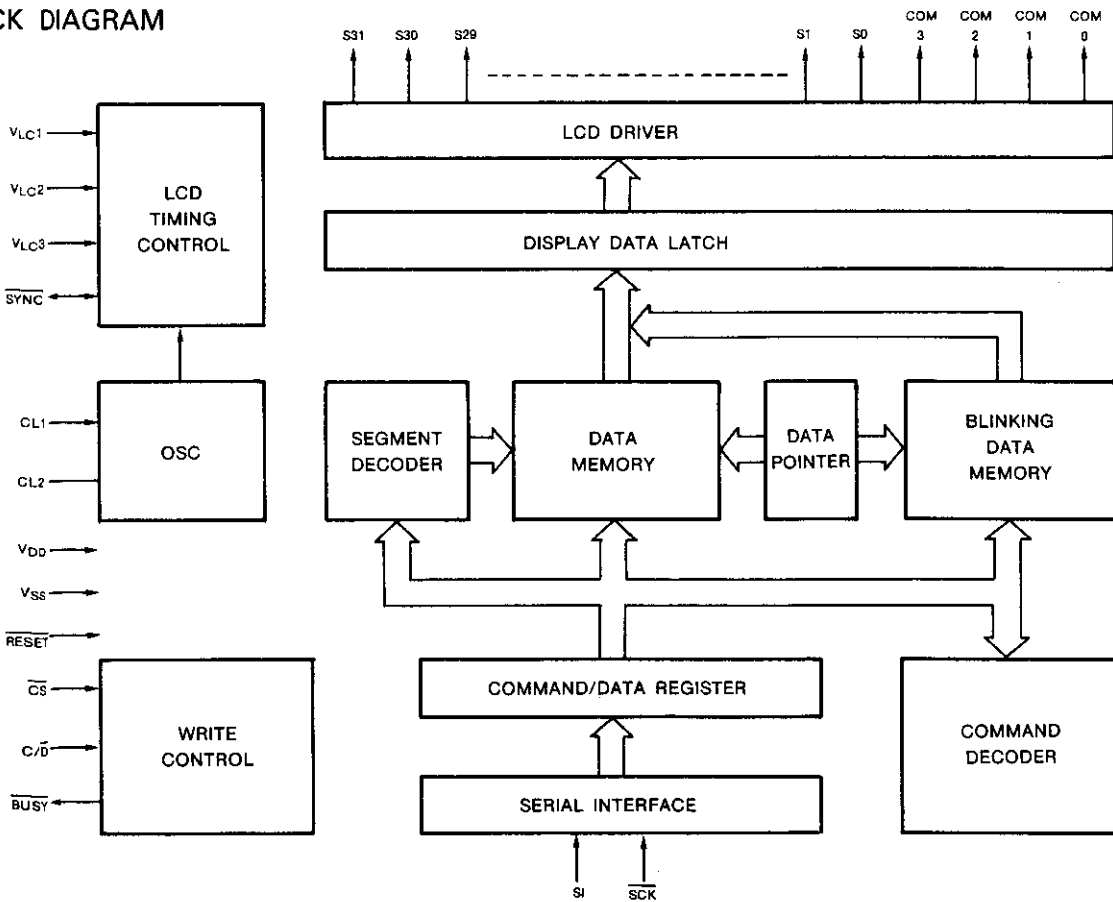

1. Pin Functions

1.1 SI (Serial Input)...Input

This is an input pin for serial data (commands/data) which inputs 19 types of commands that control the data used for the display and the operation of the μ PD7225.

1.2 SCK (Serial Clock)...Input

This is a shift clock for serial data (SI input). At the rising edge, the contents of the serial input (SI) are read to the serial register one bit at a time.

If the SCK input is "BUSY = 1" when " $\overline{\text{CS}} = 0$ ", it becomes valid, if it is "BUSY = 0" it is ignored. The SCK input is ignored when " $\overline{\text{CS}} = 1$ " regardless of the relationship to "BUSY".

1.3 C/ $\overline{\text{D}}$ (Command Data)...Input

This input pin indicates whether the serial data input from the SI pin is a command or data. A low indicates data and a high indicates a command.

1.4 $\overline{\text{BUSY}}$...3-State Output

This is an active low output pin which indicates the prohibition or approval of the input serial data. A low indicates prohibition and a high indicates approval.

A high-impedance state is set when " $\overline{\text{CS}} = 1$ ".

1.5 $\overline{\text{CS}}$ (Chip Select)...Input

Changing $\overline{\text{CS}}$ from high level to low level will clear the SCK counter of the μ PD7225 and enable the input of serial data. At the same time, the data pointer is initialized to the 0 address. When $\overline{\text{CS}}$ is set to high level following the input of serial data, the contents of the data memory are read to the display data latch and displayed on the LCD.

1.6 SYNC (Synchronous)...Input/Output

The SYNC pin is an input/output pin which connects a wired OR in cases where the common is used together in multiple chip structures, and when taking sync of a blinking operation.

The SYNC pin outputs the signal derived by dividing the clock oscillation frequency (f_{CL}) by 4 when the μ PD7225 is reset ($\overline{\text{RESET}} = 0$). (See Figure 1.) The SYNC pin takes the sync of the system clock ($f_{\text{CL}}/4$) of each μ PD7225 and after reset cancellation ($\overline{\text{RESET}} = 1$), takes the sync of the display timing of each μ PD7225 at the timing of the common drive signal illustrated in Figure 2.

Figure 1. Condition of the SYNC Pin During Reset ($\overline{\text{RESET}} = 0$)

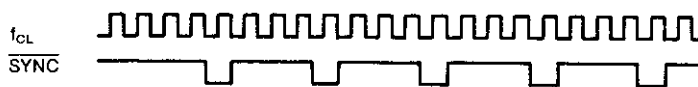
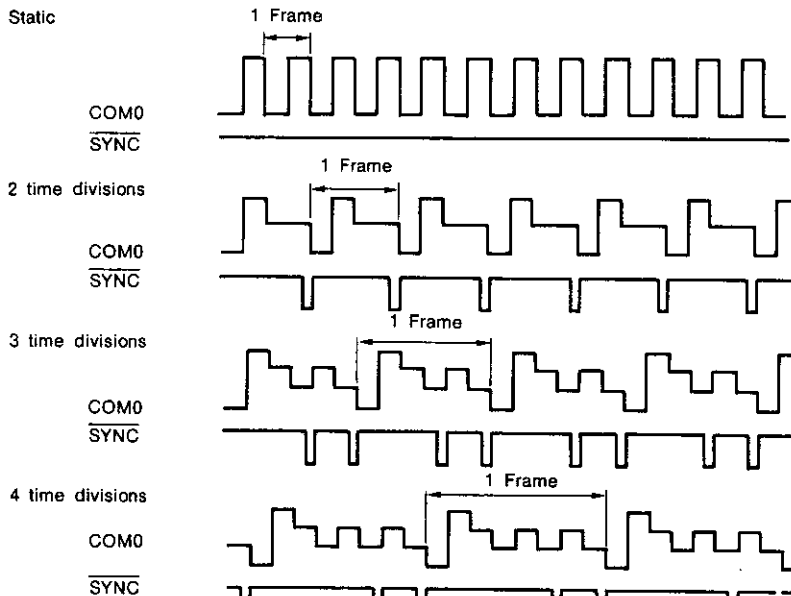

Figure 2. Condition of the SYNC Pin After Reset Cancellation ($\overline{\text{RESET}} = 1$)



1.7 $\overline{\text{RESET}}$...Input

This is an active-low reset input pin.

1.8 S0 through S31 (Segment)...Output

These are segment drive signal output pins.

1.9 COM0 through COM5 (Common)...Output

These are common drive signal output pins.

1.10 CL1 and CL2 (Clock)

These are connection pins for resistor (R) which is used for the internal clock oscillation. Input is made to pin CL1 when the clock is supplied externally.

1.11 V_{LC1} , V_{LC2} , and V_{LC3}

These are the LCD drive power supply pins.

1.12 V_{DD}

These are the positive power supply pins. Either pin number 7 or number 33 can be used.

1.13 V_{SS}

This pin is at ground potential.

RECEIVER SECTION

● LCD ASS'Y (CG1206)
(Part No.: 393 6006 007)

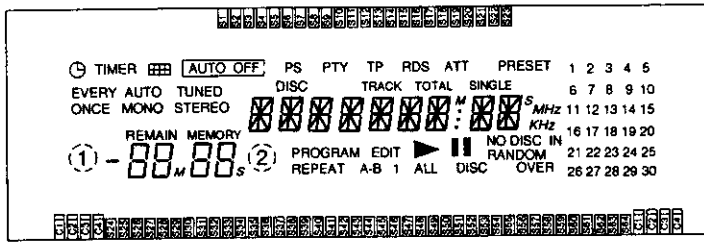

Segment

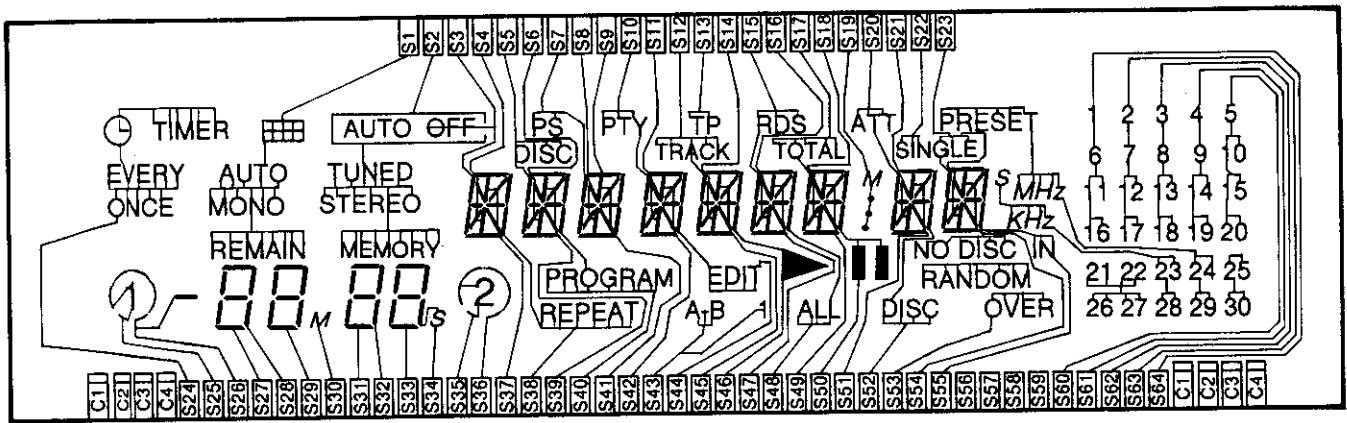

Common

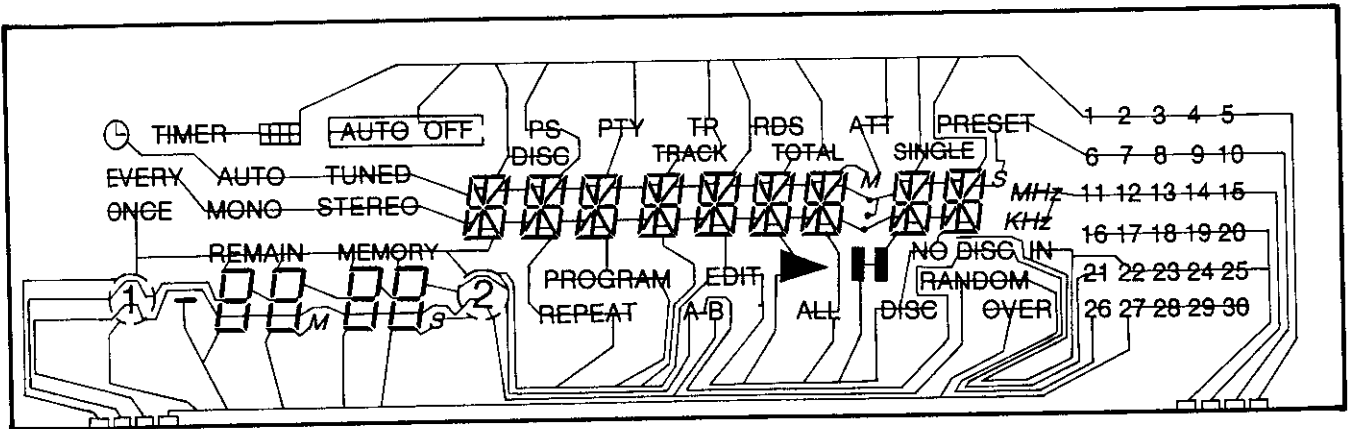

RECEIVER SECTION

● **Transistors**

2SA933S (S)
2SC1740S (S)

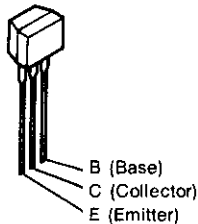

2SD1762 (E/F)

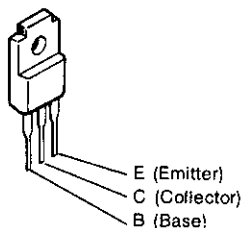

2SA935 (Q)
2SB1306 (Q/R)
2SC461 (C)
2SC2061 (Q)
2SC2390 (S)

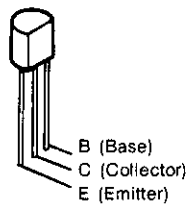

2SK365 (BL/GR)

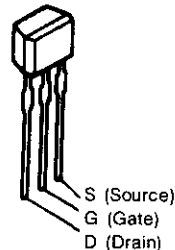

2SC2412K (S), (LN)

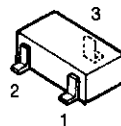

1 : Emitter
2 : Base
3 : Collector

2SK161 (GR)

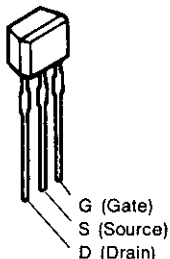

2SJ40 (C/D)

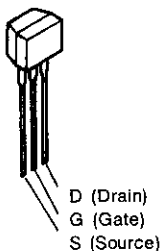

2SB1328 (P/Q)

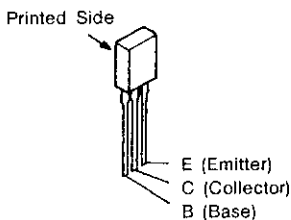

TLP181 (BL/GR)

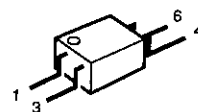

1: Anode
3: Cathode
4: Emitter
6: Collector

DTA114ES } PNP Type
DTA144ES }
DTC114ES }
DTC144ES } NPN Type
DTC124TS }
DTC323TS }
DTC124GS }
DTC143TS }

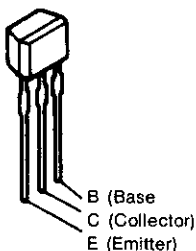

PNP Type

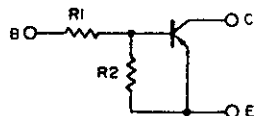

	R1	R2
DTA114ES	10k ohm	10k ohm
DTA144ES	47k ohm	47k ohm

NPN Type

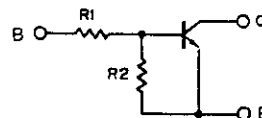

	R1	R2
DTC114ES	10k ohm	10k ohm
DTC144ES	47k ohm	47k ohm

DTA114EK } PNP Type
DTC114EK }
DTC323TK } NPN Type
DTC143TK }

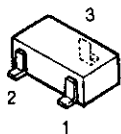

1 : Emitter
2 : Base
3 : Collector

PNP Type

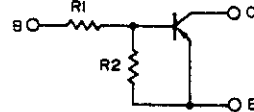

	R1	R2
DTA114EK	10k ohm	10k ohm

NPN Type

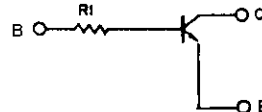

	R1
DTC143TK	4.7k ohm
DTC124TS	22k ohm
DTC323TS	2.2k ohm

NPN Type

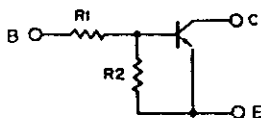

	R2
DTC124GS	22k ohm

NPN Type

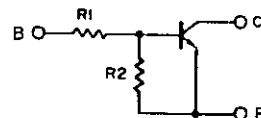

	R1	R2
DTC114EK	10k ohm	10k ohm

NPN Type

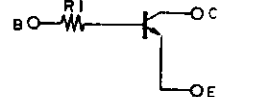

	R1
DTC323TK	2.2k ohm

RECEIVER SECTION

● **Diodes (including LED)**

MTZJ3.3A
MTZJ3.6A
MTZJ6.8A
MTZJ8.2B
MTZJ12A
MTZJ22A

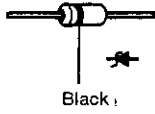

1SS252



1SR35-200A

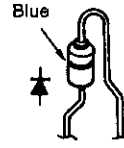

LED (SLF-351D) Ass'y
Part No. 393 9470 009 (D306)

S4VB20F (D711)

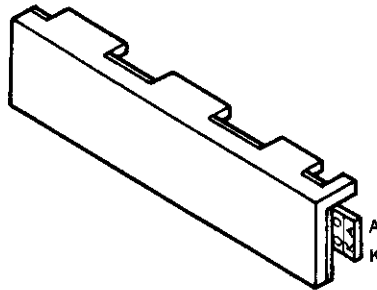
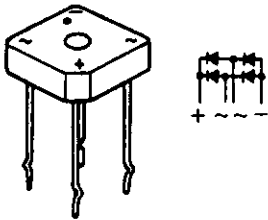

● Wiring diagram

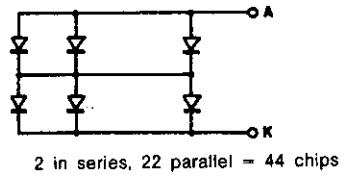

MICROPROCESSOR DOCUMENTATION
HD6433726A17F (IC404)

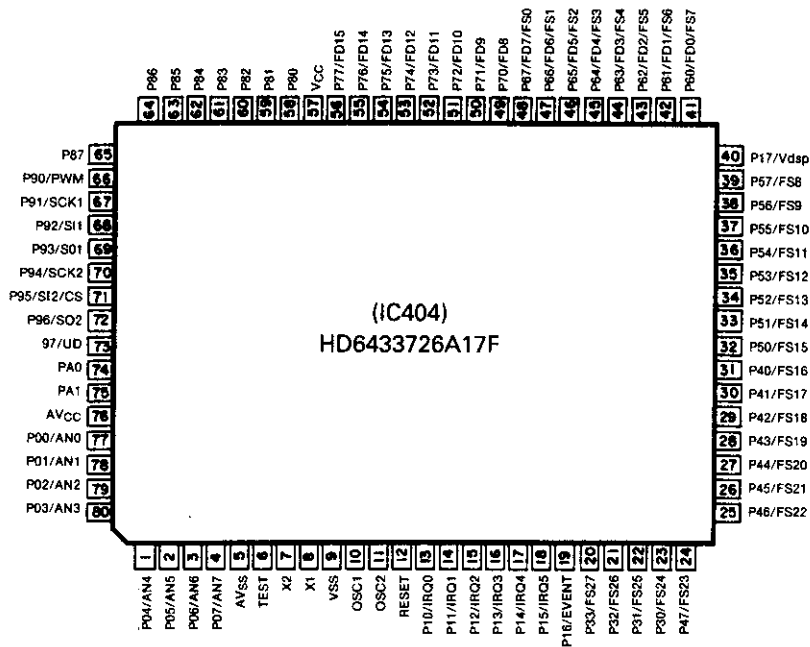

1. Overview

The functions of this microcomputer are made up of the following three pillars.

a. Tuner functions

These functions perform the required control for the reception of FM and AM broadcasts.

b. Auto functions

Positioned at the heart of the system stereo, the auto functions perform serial communications with other components (such as the deck, CD and amplifier) to provide overall control.

These functions decoder the signals from the remote control and send them to each component of the system.

c. Timer functions

Counts the clock of the 24 hour display.

Operates the three kinds of timers: Every Day, Once and Sleep.

Note 1) When the power cord is plugged in with the CB990's pin 1 and 2 short-circuited and **MEMO** pushed in, the following tracking adjustment frequencies are automatically stored in the preset memory. Use these for adjustment, etc. After setting the preset memory, undo the short circuit between CB990 pins 1 and 2.

	P1	P2	P3	P4	P5	P6
AM	522kHz	603kHz	999kHz	1098kHz	1404kHz	1611kHz
	P11	P12	P13	P14	P15	
FM	87.50MHz	89.00MHz	98.00MHz	100.10MHz	108.00MHz	

Note 2) When the power cord is plugged in while pressing both keys **MEMO** and **AUTO TUNING DOWN**, the entire memory is initialized and the microcomputer operates from the beginning of the program. If there are any problems in the frequency presetting or the time display, follow this procedure for proper start-up.

Note 3) When the power cord is plugged in while pressing both keys **MEMO** and **TIMER**, the entire LCD will alternatively light up and down. To return to the normal mode from this mode, unplug the power cord, and then plug it back in.

Note 4) When the power cord is plugged in while pressing both keys **MEMO** and **AUTO TUNING UP**, can set the power on without DENON display. To return to the normal mode from this mode, unplug the power cord, and then plug it back in.

RECEIVER SECTION

2. Receiving Band Table

Band	Receiving frequency	Local oscillator frequency	IF	Frequency division ratio	Comparison frequency	Step frequency	Other
FM	87.50~108.00MHz	98.20~118.70MHz	10.7MHz	1	25kHz	50kHz	
AM	522~1611kHz	972~2061kHz	450kHz	-	9kHz	9kHz	

3. Signals sent to the LM7000 Programmable Divider

- a. Signals to the programmable divider are sent from 3 sources: CE OUT, CLOCK OUT, and DATA OUT.
- b. The programmable divider takes in DATA at CLOCK , when CE equals 1.
- c. The data is a 24-bit serial signal which is taken in to the programmable divider from the LSB.
(At the AM setting, D₀ through D₃ are ignored, so that D₄ becomes the LSB.)
- d. The data is made up of the number of frequency divisions data, the band data, and the comparison frequency data. (See diagram below.)

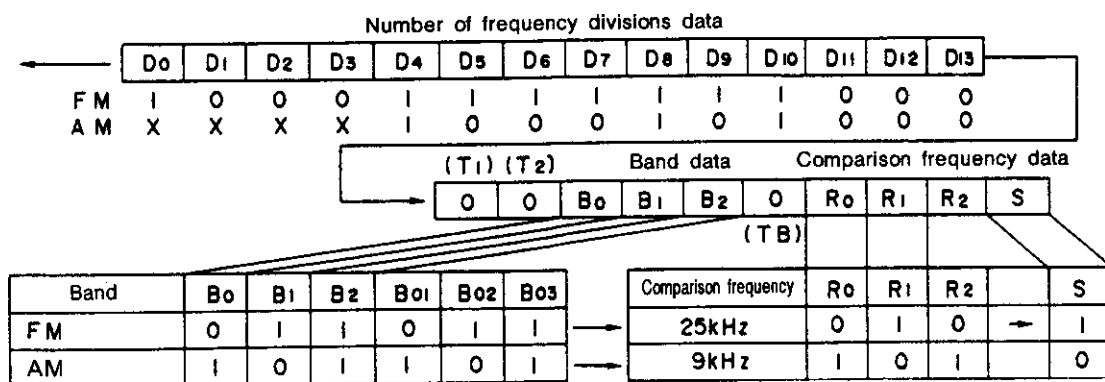

- e. Timing for sending
a = 2.5 μsec

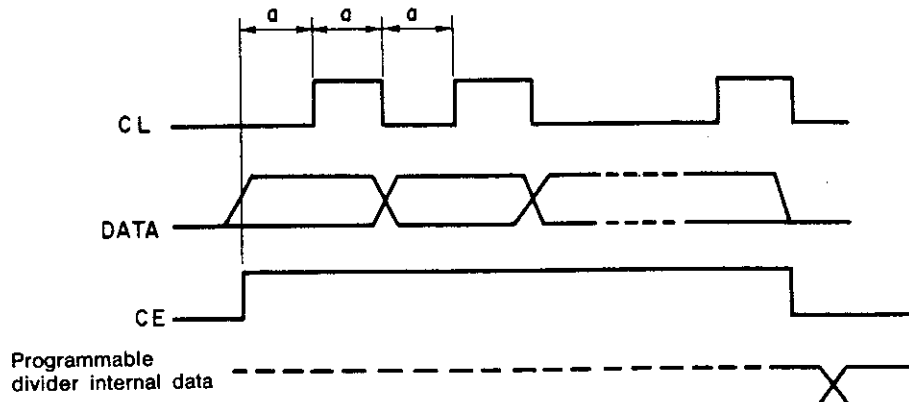

RECEIVER SECTION

● Pin Description (HD6433726A17F)

Pin	Pin No.	I/O	DFL	ACT	PUD	Function Name	Use	Function Definition
1	P04/AN4	I	H	L	U	_TUNED IN	TUNER	Tuning signal input TUNED=L
2	P05/AN5	I	H	L	U	_SIGNAL IN	TUNER	Tuning signal input SIGNAL IN=L
3	P06/AN6	I	H	L	U	_STEREO IN	TUNER	Stereo mode status input STEREO=L
4	P07/AN7	I	H	L	U	_STOP IN	PLL	PLL stop signal input STOP=L
5	AV _{SS}	I	-	-	-	GND		Ground
6	TEST	I	-	-	-			Connect to Vcc pin.
7	X2	O	-	-	-	SUB CLOCK		Sub clock oscillator pin
8	X1	I	-	-	-	SUB CLOCK		32,768 kHz
9	V _{SS}	-	-	-	-	GND		Ground
10	OSC1	I	-	-	-	SYSTEM CLOCK		System clock oscillator pin
11	OSC2	O	-	-	-	SYSTEM CLOCK		4.0 MHz
12	RESET	I	-	-	-			System reset pin
13	P10/IRQ0	I	H	L	U	_SERIAL SIG IN		Denon bus input pin
14	P11/IRQ1	I	H	L	U	50/60 Hz IN		Detection input of 50 Hz and 60 Hz pulses PULSE
15	P12/IRQ2	I	H	L	U	_REMOCON IN		Remote control signal input pin
16	P13/IRQ3	I	H	L	U	_DATA START IN		RDS data start signal input STROBE=L
17	P14/IRQ4	I	H	L	U	_OFF ENA IN		CD and deck loader close detection input OFF ENABLE=L
18	P15/IRQ5	I	L	H	U	PROTECT IN	AMP	SP pin fault detection input pin DETECT=H
19	P16/EVENT	I	-	-	-	NOT USED		
20	P33/FS27	O	L	L	D	_S_FUNC MUTE OUT	AMP	Function switching mute output pin MUTE ON=L
21	P32/FS26	O	L	H	D	PROTECT OUT	AMP	Protection circuit drive output PROTECT ON=H
22	P31/FS25	O	L	H	D	VOL DWN OUT	AMP	Volume driver drive output DOWN=L
23	P30/FS24	O	L	H	D	VOL UP OUT	AMP	Volume driver drive output UP=L
24	P47/FS23	O	H	L	D	_SDB OUT	AMP	SDB on/off, SDB circuit drive output SDB ON=L
25	P46/FS22	-	-	-	-			
26	P45/FS21	-	-	-	-			
27	P44/FS20	O	L	H	D	S. OE OUT	FUNC (LC7821)	Function switching data, chip select
28	P43/FS19	O	L	H	D	P. OE OUT	PLL (LM7000)	PLL data output, chip select
29	P42/FS18	O	L	H	D	P. STREQ OUT	PLL (LM7000)	PLL data output, stop request
30	P41/FS17	O	L	H	D	PS. DATA OUT	LM7000, LC7821	PLL and function data output
31	P40/FS16	O	L	H	D	PS CLK OUT	LM7000, LC7821	PLL and function clock output
32	P50/FS15	O	L	H	D	L. CLK OUT	DSPLY (UPD7225G)	LCD display driver data output
33	P51/FS14	O	L	H	D	L. DATA OUT	DSPLY (UPD7225G)	LCD display driver data output
34	P52/FS13	O	H	L	D	_L. CE1 OUT	DSPLY (UPD7225G)	LCD display driver data output (Chip select 1) CHIP SEL=L
35	P53/FS12	O	H	L	D	_L. CE2 OUT	DSPLY (UPD7225G)	LCD display driver data output (Chip select 2) CHIP SEL=L
36	P54/FS11	I	H	L	U	_L. BSY IN	DSPLY (UPD7225G)	LCD display driver data output, busy input BUSY=L
37	P55/FS10	O	L	H	D	L. C/_D OUT	DSPLY (UPD7225G)	LCD display driver data output (Command = H, Data = L)
38	P56/FS9	O	L	L	D	_LSI. RST OUT		Peripheral LSI reset output RESET=L
39	P57/FS8	O	L	H	D	LOCAL/_DX OUT		Local/DX switching output DX=L
40	P17/Vdsp	I	-	-	-	NOT USED		
41	P60/FD0/FS7	I/O				NOT USED		
42	P61/FD1/FS6	I/O				NOT USED		
43	P62/FD2/FS5	I/O				NOT USED		
44	P63/FD3/FS4	O	L	H	D	KS0		Key strobe pin
45	P64/FD4/FS3	O	L	H	D	KS1		Key strobe pin
46	P65/FD5/FS2	O	L	H	D	KS2		Key strobe pin
47	P66/FD6/FS1	O	L	H	D	KS3		Key strobe pin
48	P67/FD7/FS0	O	L	H	D	KS4		Key strobe pin
49	P70/FD8	O	L	H	D	KS5		Key strobe pin
50	P71/FD9	O	L	H	D	KS6		Key strobe pin
51	P72/FD10	O	L	H	D	KS7		Key strobe pin
52	P73/FD11	O	L	H	D	KS8		Key strobe pin
53	P74/FD12	O	L	H	D	KS9		Key strobe pin
54	P75/FD13	O	L	H	D	KS10		Key strobe pin
55	P76/FD14	O	L	H	D	KS11		Key strobe pin
56	P77/FD15	O	L	H	D	KS12		Key strobe pin
57	V _{CC}	I	-	-	-			Power supply input pin
58	P80	O	H	L		_TAPE REC OUT	AMP	Function = tape status output TAPE=L
59	P81	O	H	L		_RELAY OUT	TUNER	Power supply relay control output RELAY ON=L
60	P82	O	L	L		_T. MUTE OUT	TUNER	Tuner mute output MUTE ON=L
61	P83	O	L	L		_AUTO/MONO OUT	TUNER	FM Auto/Mon switching output AUTO=L
62	P84	O	H	L		PWR_ON/OFF OUT	TUNER	Power on/off status output POWER ON=L
63	P85	I/O				NOT USED		
64	P86	O	L	H	D	PS CLK OUT	LM7000, LC7821	PLL and function data output
65	P87	O	L	H	D	PS. DATA OUT	LM7000, LC7821	PLL and function data output
66	P90/PWM	O	H	L		_SERIAL SIG OUT	SYSTEM	Denon bus output pin
67	P91/SCK1	I	L	H	U	R. CLK IN	TUNER (LM7070NM)	RDS data input pin
68	P92/SH	I	L	H	U	R. DATA IN	TUNER (LM7070NM)	RDS data input pin
69	P93/SO1	I/O				NOT USED		
70	P94/SCK2	I	L	H	U	CLK IN	CD/DECK	CD and deck display data clock pin
71	P95/SI2/CS	I	L	H	U	DATA IN	CD/DECK	CD and deck display data input pin
72	P96/SO2	O	H	L		ENABLE OUT	CD/DECK	Display data transmission enable output CD=L, DECK=H
73	P97/UD	O	L	H		DIMMER OUT		Dimmer on/off output ON=H
74	PA0	O	L	H		SUB CHK		Sub check
75	PA1	O	L	H				
76	AV _{CC}	-	-	-	-			Connected to Vcc pin
77	P00/AN0	I	L	H	D	KR0		Key input pin
78	P01/AN1	I	L	H	D	KR1		Key input pin
79	P02/AN2	I	L	H	D	KR2		Key input pin
80	P03/AN3	I	L	H	D	KR3		Key input pin

RECEIVER SECTION

• Description of Key and Selection Switch Inputs

No.	Function Name	Function																														
1	TUNING UP	※In the tuner mode Changes the receiving frequency upward one step at a time. When held for 0.5 seconds or longer, the change is continuous. The unit enters the auto tuning mode the moment the key is released. Pressing the key again engages the step operation. ※In the clock mode Increments the figures while they are flashing.																														
2	TUNING DOWN	※In the tuner mode Changes the receiving frequency downward one step at a time. When held for 0.5 seconds or longer, the change is continuous. The unit enters the auto tuning mode the moment the key is released. Pressing the key again engages the step operation. ※In the clock mode Decrements the figures while they are flashing.																														
3	PRESET UP	Increments the preset number from the current value, and receives that preset station. At the time of the RDS PTY search, becomes the key which selects the program type.																														
4	PRESET DOWN	Decrements the preset number from the current value, and receives that preset station. At the time of the RDS PTY search, becomes the key which selects the program type.																														
5	BAND	Operates in a cyclic manner to specify switching to the FM or AM receiving modes.																														
6	MONO/AUTO	At the time of FM reception, specifies the switching of the receiving mode between the mono/auto mode and the forced mono mode.																														
7	MEMORY	Provides a transition to the mode which registers the stations being received to preset memory. The "MEMO" display will flash. Registration is accomplished by pressing the tuning up or down keys and then press the MEMO key.																														
8	ENTER/NEXT	This is used when setting the timer, setting the current time, and when advancing to the next operation.																														
9	TIMER	Provides a transition to the setting mode which operates the timer only once each day at the set time.																														
10	STAND BY	Pressing this key selects whether or not the timer operation is performed. To engage the timer operation, use this key to light the stand by mark on the LCD.																														
11	CLEAR	This button is used to change the current time setting or the contents of the set timer.																														
12	DISPLAY	This button switches the display to the reception frequency and time and TAPE COUNTER display. Pressing this button for 3 seconds or longer changes the function to the time setting mode.																														
13	RDS	Use this button to automatically tune to stations using the radio data system. One press engages the RDS search, two presses engage the PTY search, and three presses engage the TP search mode.																														
14	LOCAL/DX (RF ATT.)	Use this to select the FM sensitivity, local or DX.																														
15	USA. EUROPE. FREQ.	Destination selection and setting switch <table border="1" style="margin-left: 20px;"> <thead> <tr> <th style="text-align: center;">Destination</th> <th style="text-align: center;">3W</th> <th style="text-align: center;">USA</th> <th style="text-align: center;">Europe</th> <th style="text-align: center;">Freq.</th> </tr> </thead> <tbody> <tr> <td>USA</td> <td></td> <td style="text-align: center;">1</td> <td style="text-align: center;">0</td> <td style="text-align: center;">0</td> </tr> <tr> <td>Europe</td> <td></td> <td style="text-align: center;">0</td> <td style="text-align: center;">1</td> <td style="text-align: center;">0</td> </tr> <tr> <td>Southeast Asia</td> <td></td> <td style="text-align: center;">1</td> <td style="text-align: center;">1</td> <td style="text-align: center;">0</td> </tr> <tr> <td>Japan</td> <td></td> <td style="text-align: center;">0</td> <td style="text-align: center;">0</td> <td style="text-align: center;">0</td> </tr> <tr> <td>Middle East</td> <td></td> <td style="text-align: center;">0</td> <td style="text-align: center;">0</td> <td style="text-align: center;">1</td> </tr> </tbody> </table> <p style="margin-left: 20px;">NOTE: "1" : Shorted with a diode "0" : Open</p>	Destination	3W	USA	Europe	Freq.	USA		1	0	0	Europe		0	1	0	Southeast Asia		1	1	0	Japan		0	0	0	Middle East		0	0	1
Destination	3W	USA	Europe	Freq.																												
USA		1	0	0																												
Europe		0	1	0																												
Southeast Asia		1	1	0																												
Japan		0	0	0																												
Middle East		0	0	1																												

MICROPROCESSOR PERIPHERAL WIRING DIAGRAM

RECEIVER SECTION

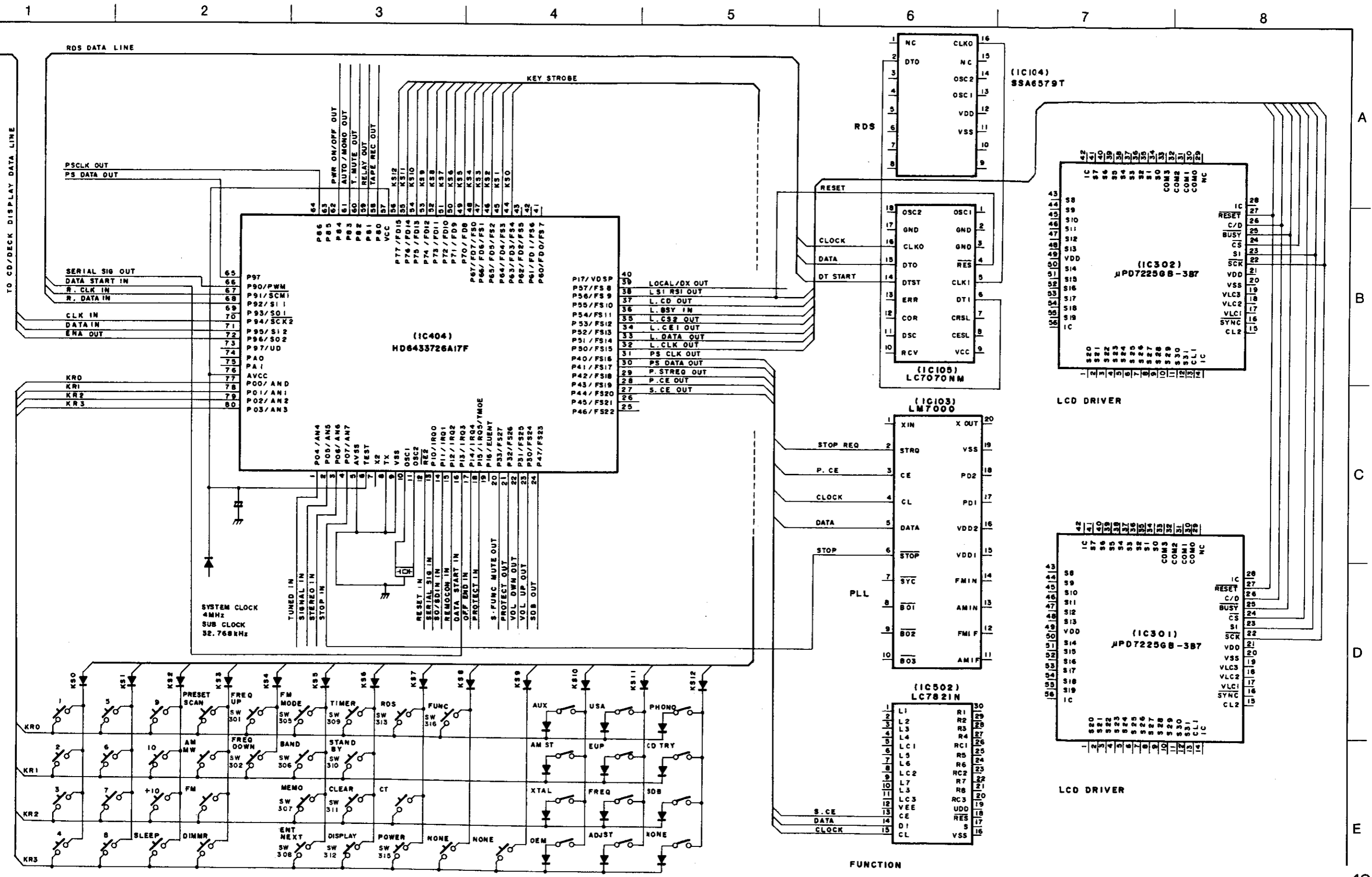

RECEIVER SECTION

PRINTED WIRING BOARD

1 2 3 4 5 6 7 8

KU-9333 TUNER UNIT ASS'Y

Component Side

KU-9333 TUNER UNIT ASS'Y

1	TUNER UNIT
2	DISPLAY UNIT
3	TONE UNIT
4	HEADPHONE UNIT

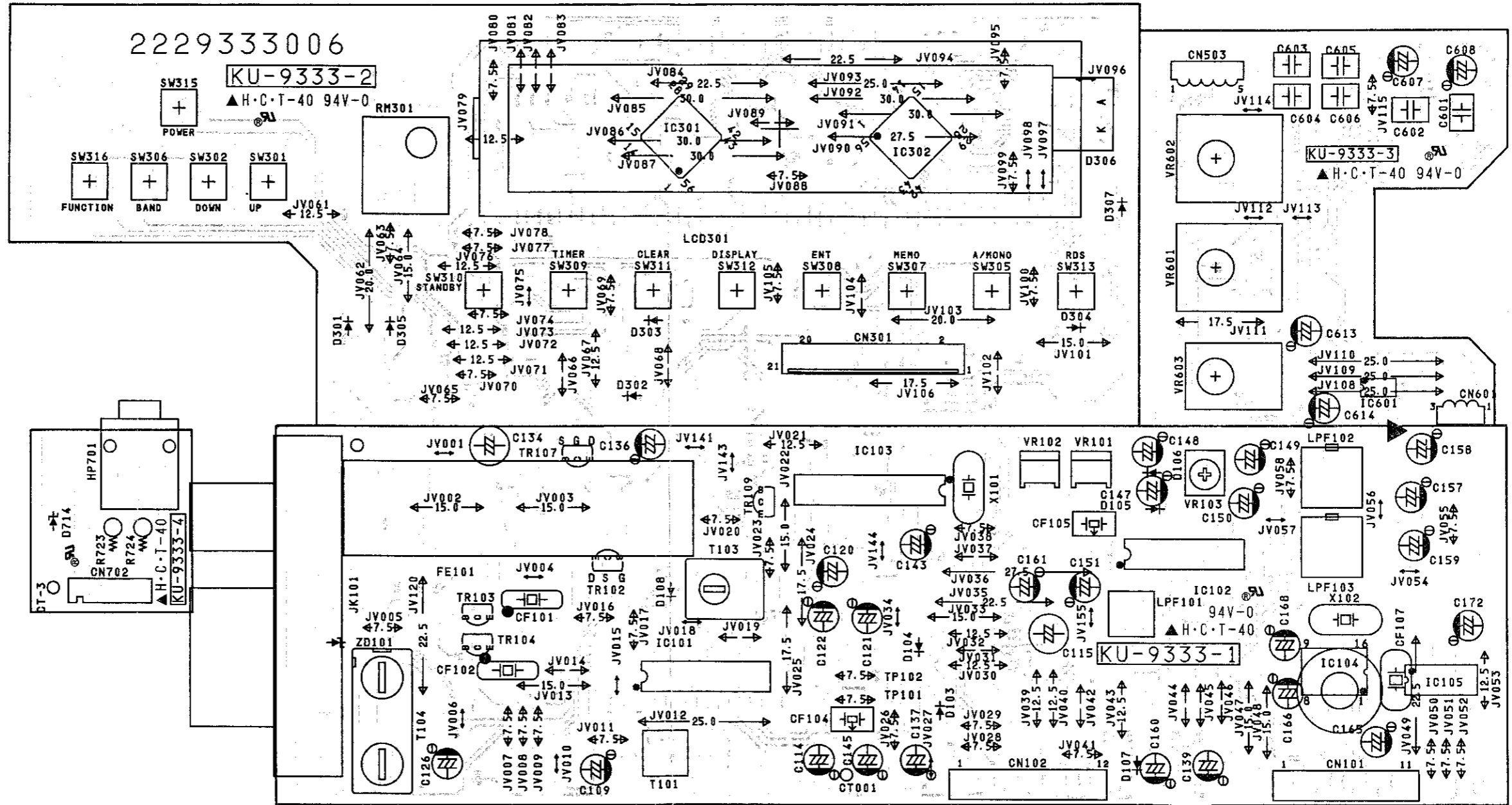

A
B
C
D
E

RECEIVER SECTION

1 2 3 4 5 6 7 8

Pattern Side

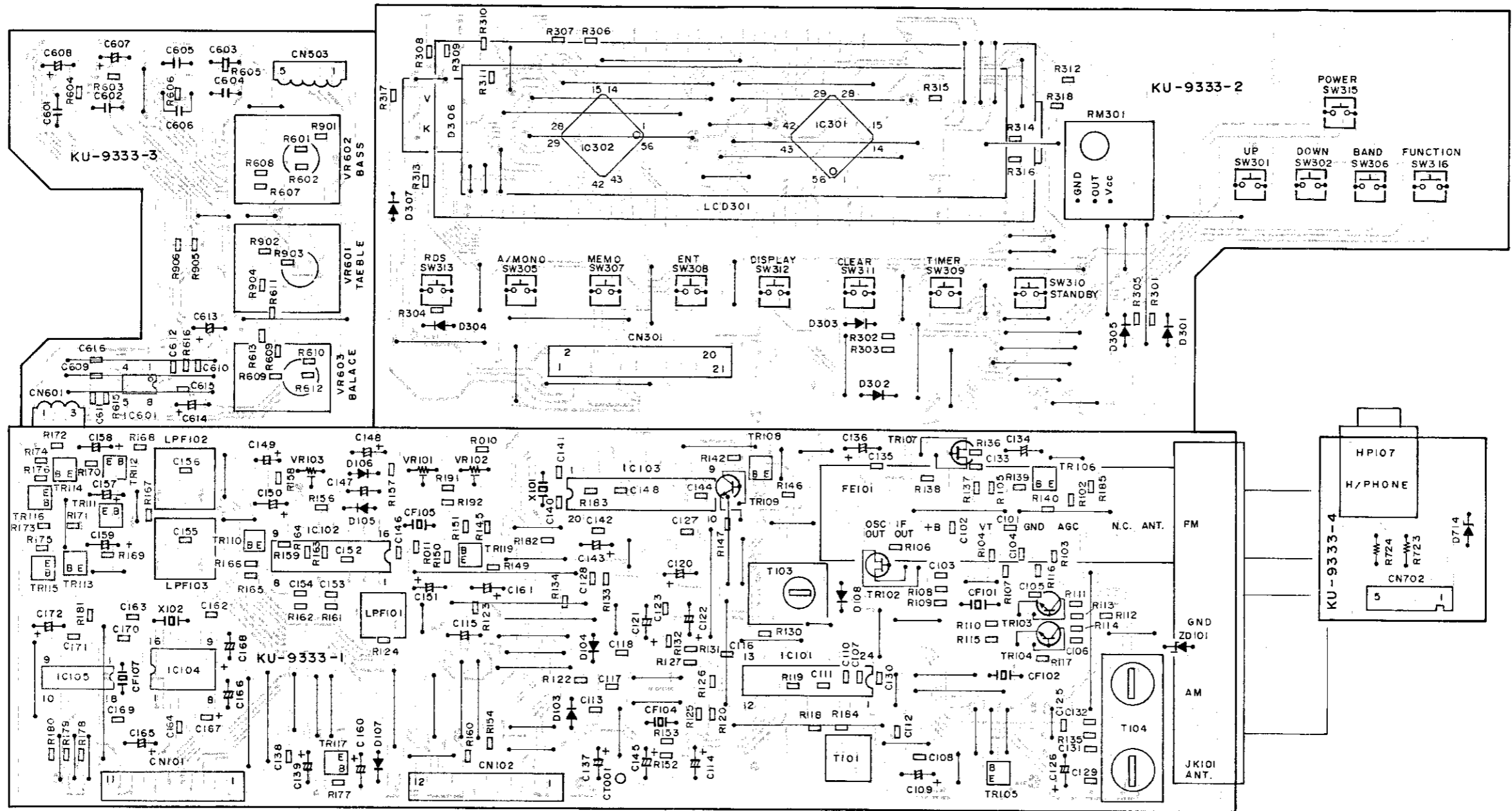

A

B

C

D

E

RECEIVER SECTION

1 2 3 4 5 6 7 8

KU-9332 MAIN UNIT ASS'Y

Component Side

KU-9332 MAIN UNIT ASS'Y	
1	MAIN UNIT
2	INPUT & BUFFER UNIT
3	VOLUME UNIT
4	AC IN UNIT

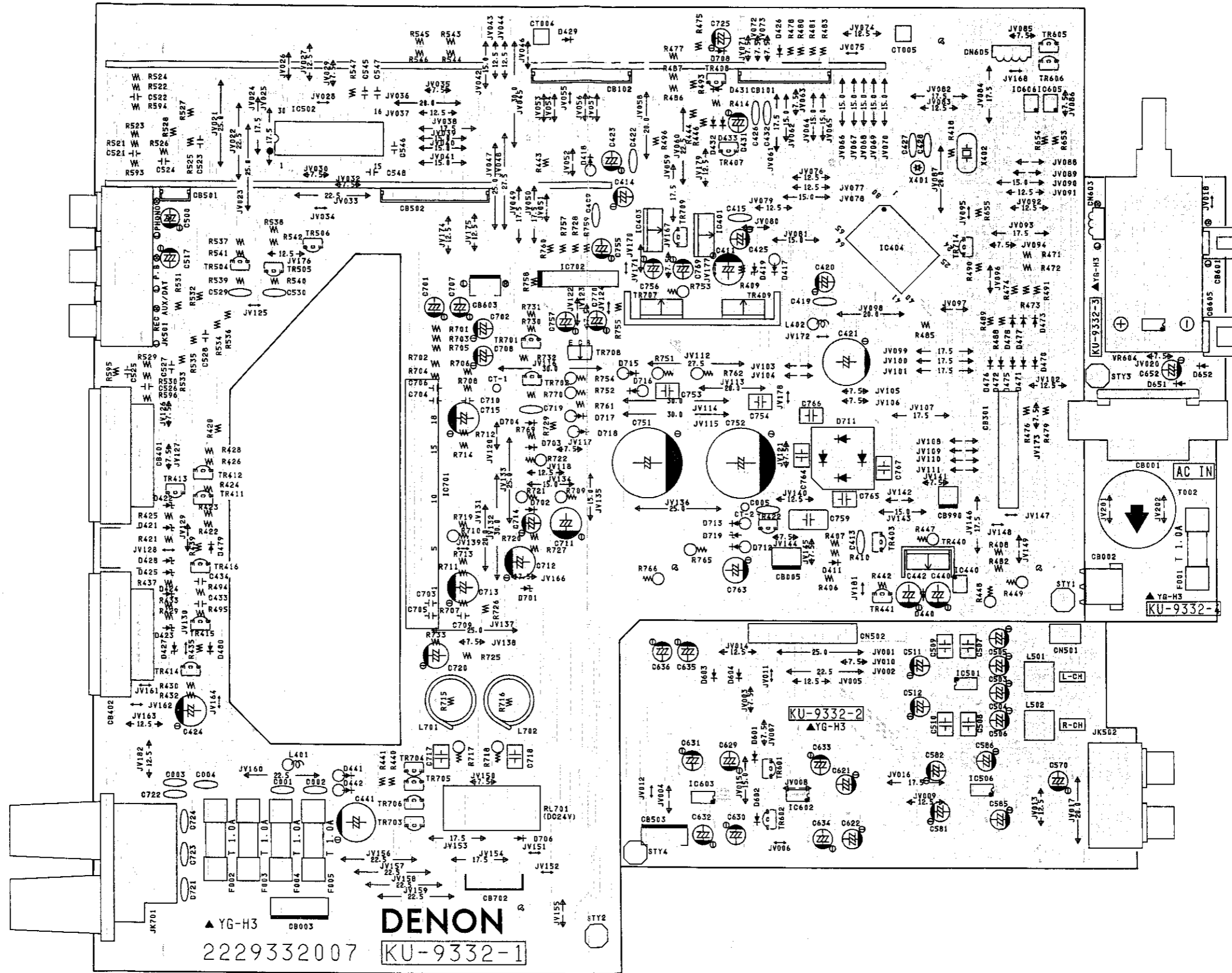

RECEIVER SECTION

1 2 3 4 5 6 7 8

Pattern Side

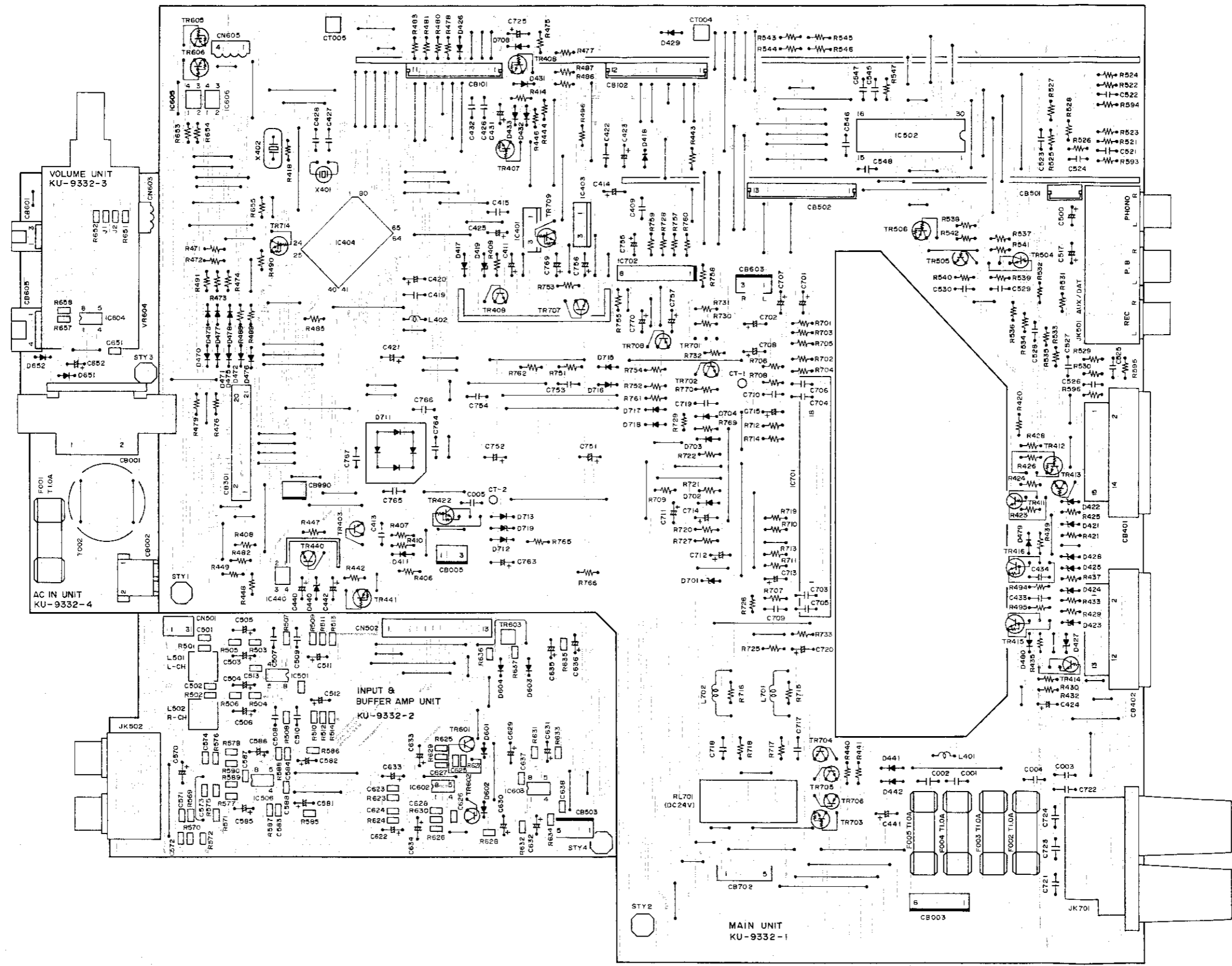

A
B
C
D
E

RECEIVER SECTION

NOTE ON PARTS LIST

- Part indicated with the mark "●" are not always in stock and possibly to take a long period of time for supplying, or in some case supplying of part may be refused.
- When ordering of part, clearly indicate "1" and "1" (i) to avoid mis-supplying.
- Ordering part without stating its part number can not be supplied.
- Part indicated with the mark "★" is not illustrated in the exploded view.
- Not including Carbon Film ±5%, 1/4W Type in the P.W. Board parts list. (Refer to the Schematic Diagram for those parts.)

WARNING:

Parts marked with this symbol Δ \square have critical characteristics.
Use ONLY replacement parts recommended by the manufacturer.

● **Resistors**

Ex.: **RN** **14K** **2E** **182** **G** **FR**
 Type Shape and performance Power Resistance Allowable error Others

RD : Carbon Film	2B : 1/8W	F : ±1%	P : Pulse-resistant type
RC : Composition	2E : 1/4W	G : ±2%	NL : Low noise type
RS : Metallic oxide Film	2H : 1/2W	J : ±5%	NB : Non-burning type
RW : Winding	3A : 1W	K : ±10%	FR : Fuse-resistor
RN : Metal film	3D : 2W	M : ±20%	F : Lead wire forming
RK : Metal mixture	3F : 3W		
	3H : 5W		

* **Resistance**

1 8 2 ⇒ 1800 ohm = 1.8 kohm
 ↑ ↑ ↑
 Indicates number of zeros after effective number
 2-digit effective number

• Units: ohm

1 R 2 ⇒ 1.2 ohm
 ↑ ↑ ↑
 1-digit effective number.
 2-digit effective number, decimal point indicated by R.

• Units: ohm

* **Capacity (electrolyte only)**

2 2 R ⇒ 2200 μF
 ↑ ↑ ↑
 Indicates number of zeros after effective number.
 2-digit effective number.

• Units: μF

2 R 2 ⇒ 2.2 μF
 ↑ ↑ ↑
 1-digit effective number.
 2-digit effective number, decimal point indicated by R.

• Units: μF

● **Capacitors**

Ex.: **CE** **04W** **1H** **2R2** **M** **BP**
 Type Shape and performance Dielectric strength Capacity Allowable error Others

CE : Aluminum foil electrolyte	0J : 6.3V	F : ±1%	HS : High stability type
CA : Aluminum solid electrolyte	1A : 10V	G : ±2%	BP : Non-polar type
CS : Tantalum electrolyte	1C : 16V	J : ±5%	HR : Ripple-resistant type
CQ : Film	1E : 25V	K : ±10%	DL : For charge and discharge
CK : Ceramic	1V : 35V	M : ±20%	HF : For assuring high frequency
CC : Ceramic	1H : 50V	Z : +80%	U : UL part
CP : Oil	2A : 100V	-20%	C : CSA part
CM : Mica	2B : 125V	P : +100%	W : UL-CSA type
CF : Metallized	2C : 160V	-0%	F : Lead wire forming
CH : Metallized	2D : 200V	C : ±0.25pF	
	2E : 250V	D : ±0.5pF	
	2H : 500V	-	
	2J : 630V	-	

* **Capacity (except electrolyte)**

2 R 2 ⇒ 2200pF = 2200 μF = 0.002 μF
 ↑ ↑ ↑
 (More than 2) — Indicates number of zeros after effective number.
 2-digit effective number.

• Units: μF

2 2 1 ⇒ 220pF
 ↑ ↑ ↑
 (0 or 1) — Indicates number of zeros after effective number.
 2-digit effective number.

• Units: pF

• When the dielectric strength is indicated in AC, "AC" is included after the dielectric strength value.

KU-9333 PARTS LIST OF UDRA-77

Ref. No.	Part No.	Part Name	Remarks	Ref. No.	Part No.	Part Name	Remarks
SEMICONDUCTORS GROUP							
IC101	263 0421 002	IC LA1267		R118	247 0010 961	Chip Carbon 22 kohm 1/10W	RM73B--223J
IC102	263 0284 004	IC LA3410		R119	247 0011 960	Chip Carbon 56 kohm 1/10W	RM73B--563J
IC103	262 0703 002	IC LM7000		R120	247 0006 962	Chip Carbon 470 ohm 1/10W	RM73B--471J
IC104	262 1701 906	IC 5AA6579T-T		R122	247 0008 944	Chip Carbon 2.7 kohm 1/10W	RM73B--272J
IC105	263 0614 903	IC LC7070NM-TE-R		R123	247 0010 961	Chip Carbon 22 kohm 1/10W	RM73B--223J
				R124	247 0007 990	Chip Carbon 1.6 kohm 1/10W	RM73B--162J
				R125	247 0004 980	Chip Carbon 820 ohm 1/10W	RM73B--820J
IC301,302	263 0912 003	IC UPD7225GB-3B7		R126	247 0010 990	Chip Carbon 30 kohm 1/10W	RM73B--303J
				R127	247 0009 956	Chip Carbon 7.5 kohm 1/10W	RM73B--752J
				R130~132	247 0009 985	Chip Carbon 10 kohm 1/10W	RM73B--103J
IC601	263 0615 902	IC BA15218F		R133	247 0011 986	Chip Carbon 68 kohm 1/10W	RM73B--683J
TR102	275 0051 909	FET 2SK161(GR)		R134	247 0011 944	Chip Carbon 47 kohm 1/10W	RM73B--473J
TR103,104	273 0025 926	Transistor 2SC461P(C)		R135	247 0012 927	Chip Carbon 100 kohm 1/10W	RM73B--104J
TR105	269 0083 901	Transistor DTA114EK	Built in Resistor	R136	247 0008 928	Chip Carbon 2.2 kohm 1/10W	RM73B--222J
TR106	273 0426 907	Transistor 2SC2412KLN		R137	247 0010 961	Chip Carbon 22 kohm 1/10W	RM73B--223J
TR107	275 0053 907	FET 2SK365(BL/GR)		R138,139	247 0005 989	Chip Carbon 220 ohm 1/10W	RM73B--221J
TR108	269 0083 901	Transistor DTA114EK	Built in Resistor	R140	247 0006 962	Chip Carbon 470 ohm 1/10W	RM73B--471J
TR109	273 0025 926	Transistor 2SC461P(C)		R142	247 0007 945	Chip Carbon 1 kohm 1/10W	RM73B--102J
TR110	273 0384 900	Transistor 2SC2412K(S)		R145	247 0009 985	Chip Carbon 10 kohm 1/10W	RM73B--103J
TR111,112	273 0426 907	Transistor 2SC2412KLN		R146,147	247 0007 945	Chip Carbon 1 kohm 1/10W	RM73B--102J
TR113,114	269 0066 902	Transistor DTC323TK	Built in Resistor	R148	247 0012 969	Chip Carbon 150 kohm 1/10W	RM73B--154J
TR115,116	269 0091 906	Transistor DTC143TK	Built in Resistor	R149	247 0007 945	Chip Carbon 1 kohm 1/10W	RM73B--102J
TR117	269 0083 901	Transistor DTA114EK	Built in Resistor	R150	247 0010 961	Chip Carbon 22 kohm 1/10W	RM73B--223J
TR119	273 0384 900	Transistor 2SC2412K(S)		R152	247 0011 931	Chip Carbon 43 kohm 1/10W	RM73B--433J
				R151	247 0009 985	Chip Carbon 10 kohm 1/10W	RM73B--103J
D101	276 0643 941	Zener Diode MTZJ3.6A		R153	247 0009 927	Chip Carbon 5.6 kohm 1/10W	RM73B--562J
D103~108	276 0616 907	Diode 1SS252		R154	247 0009 985	Chip Carbon 10 kohm 1/10W	RM73B--103J
				R156	247 0008 928	Chip Carbon 2.2 kohm 1/10W	RM73B--222J
D301~305	276 0616 907	Diode 1SS252		R157	247 0007 945	Chip Carbon 1 kohm 1/10W	RM73B--102J
D306	393 9470 009	LED Ass'y		R158	247 0010 990	Chip Carbon 27 kohm 1/10W	RM73B--273J
D307	276 0616 907	Diode 1SS252		R159	247 0012 927	Chip Carbon 100 kohm 1/10W	RM73B--104J
				R160	247 0009 985	Chip Carbon 10 kohm 1/10W	RM73B--103J
D714	276 0636 903	Zener Diode MTZJ8.2B		R161~164	247 0012 969	Chip Carbon 150 kohm 1/10W	RM73B--154J
				R165,166	247 0008 931	Chip Carbon 2.4 kohm 1/10W	RM73B--242J
LC301	393 6006 007	LCD(CG1206) Ass'y		R167~170	247 0009 927	Chip Carbon 5.6 kohm 1/10W	RM73B--562J
RESISTORS GROUP (Not included Carbon Film ±5%, 1/4W Type. Refer to the Schematic Diagram for those Parts.)							
R011	247 0018 905	Chip Carbon 0 ohm 1/10W	RM73B--0R0K	R171~174	274 0005 992	Chip Carbon 240 ohm 1/10W	RM73B--241J
R102	247 0010 961	Chip Carbon 22 kohm 1/10W	RM73B--223J	R175,176	247 0009 985	Chip Carbon 10 kohm 1/10W	RM73B--103J
R103	247 0010 987	Chip Carbon 27 kohm 1/10W	RM73B--273J	R177	247 0009 927	Chip Carbon 5.6 kohm 1/10W	RM73B--562J
R104	247 0003 949	Chip Carbon 22 ohm 1/10W	RM73B--220J	R178~180	247 0011 944	Chip Carbon 47 kohm 1/10W	RM73B--473J
R105	247 0007 945	Chip Carbon 1 kohm 1/10W	RM73B--102J	R181~183	247 0009 985	Chip Carbon 10 kohm 1/10W	RM73B--103J
R106	247 0006 917	Chip Carbon 300 ohm 1/10W	RM73B--301J	R184	247 0018 905	Chip Carbon 0 ohm 1/10W	RM73B--0R0K
R107	247 0005 905	Chip Carbon 100 ohm 1/10W	RM73B--101J	R185	247 0009 985	Chip Carbon 10 kohm 1/10W	RM73B--103J
R108	247 0005 976	Chip Carbon 200 ohm 1/10W	RM73B--201J				
R109	247 0005 905	Chip Carbon 100 ohm 1/10W	RM73B--101J	R301~305	247 0011 944	Chip Carbon 47 kohm 1/10W	RM73B--473J
R110	247 0006 920	Chip Carbon 330 ohm 1/10W	RM73B--331J	R306	247 0012 985	Chip Carbon 180 kohm 1/10W	RM73B--184J
R111	247 0010 945	Chip Carbon 18 kohm 1/10W	RM73B--183J	R307	247 0018 905	Chip Carbon 0 ohm 1/10W	RM73B--0R0K
R112	247 0009 985	Chip Carbon 10 kohm 1/10W	RM73B--103J	R308~310	247 0009 985	Chip Carbon 10 kohm 1/10W	RM73B--103J
R113,114	247 0009 985	Chip Carbon 10 kohm 1/10W	RM73B--103J	R311	247 0007 987	Chip Carbon 1.5 kohm 1/10W	RM73B--152J
R115	247 0007 945	Chip Carbon 1 kohm 1/10W	RM73B--102J	R312~316	247 0009 985	Chip Carbon 10 kohm 1/10W	RM73B--103J
R116	247 0005 905	Chip Carbon 100 ohm 1/10W	RM73B--101J	R317	247 0007 932	Chip Carbon 910 ohm 1/10W	RM73B--911J
R117	247 0006 920	Chip Carbon 330 ohm 1/10W	RM73B--331J	R318	247 0009 901	Chip Carbon 4.7 kohm 1/10W	RM73B--472J

RECEIVER SECTION

Ref. No.	Part No.	Part Name	Remarks	Ref. No.	Part No.	Part Name	Remarks
R601,602	247 0009 974	Chip Carbon 24 kohm 1/10W	RM73B--243J	C143	254 4258 905	Electrolytic 4.7 μ F/35V	CE04W1V4R7M(SME)
R603,604	247 0009 985	Chip Carbon 10 kohm 1/10W	RM73B--103J	C144	257 0004 961	Chip Ceramic 100 pF/50V	CC73SL1H101J
R605,606	247 0005 989	Chip Carbon 220 ohm 1/10W	RM73B--221J	C145	254 4258 905	Electrolytic 4.7 μ F/35V	CE04W1V4R7M(SME)
R607,608	247 0010 961	Chip Carbon 22 kohm 1/10W	RM73B--223J	C146	257 1013 951	Chip Ceramic 0.047 μ F/25V	CK73B1E473K
R609,610	247 0011 928	Chip Carbon 39 kohm 1/10W	RM73B--393J	C147	254 4260 935	Electrolytic 0.47 μ F/50V	CE04W1HR47M(SME)
R611,612	247 0007 945	Chip Carbon 1 kohm 1/10W	RM73B--102J	C148	254 4260 964	Electrolytic 3.3 μ F/50V	CE04W1H3R3M(SME)
R613,614	247 0009 901	Chip Carbon 4.7 kohm 1/10W	RM73B--472J	C149	254 4254 909	Electrolytic 10 μ F/16V	CE04W1C100M(SME)
R615,616	247 0014 967	Chip Carbon 1 Mohm 1/10W	RM73B--105J	C150	254 4260 948	Electrolytic 1 μ F/50V	CE04W1H010M(SME)
Δ R723,724	244 2055 941	Metal Oxide 330 ohm	RS14B3A331JNBS	C151	254 4254 938	Electrolytic 47 μ F/16V	CE04W1C470M(SME)
R901~906	247 0018 905	Chip Carbon 0 ohm 1/10W	RM73B--0R0K	C152~154	257 0005 986	Chip Ceramic 330 pF/50V	CC73SL1H331J
VR102	211 6095 952	Semi Fixed Resistor 100 kohm	V06QB104	C155,156	257 0009 924	Chip Ceramic 2200 pF/50V	CK73B1H222K
VR103	211 6093 970	Semi Fixed Resistor 100 kohm	V06PB104	C157	254 4254 938	Electrolytic 47 μ F/16V	CE04W1C470M(SME)
VR601,602	211 9103 003	Variable Resistor 50 kohm	V1420P15FB503K	C158,159	254 4260 951	Electrolytic 2.2 μ F/50V	CE04W1H2R2M(SME)
VR603	211 9105 001	Variable Resistor 50 kohm	V11P15FW503-	C160	254 4254 909	Electrolytic 10 μ F/16V	CE04W1C100M(SME)
CAPACITORS GROUP				C161	254 4252 930	Electrolytic 100 μ F/10V	CE04W1A101M(SME)
C101~106	257 0012 966	Chip Ceramic 0.01 μ F/50V	CK73F1H103Z	C162,163	257 0016 962	Chip Ceramic 27 μ F/50V	CC73CH1H270J
C107,108	257 0012 982	Chip Ceramic 0.022 μ F/50V	CK73F1H223Z	C164	257 0004 961	Chip Ceramic 100 pF/50V	CC73SL1H101J
C109	254 4254 909	Electrolytic 10 μ F/16V	CE04W1C100M(SME)	C165	254 4260 951	Electrolytic 2.2 μ F/50V	CE04W1H2R2M(SME)
C110	257 0012 982	Chip Ceramic 0.022 μ F/50V	CK73F1H223Z	C166	254 4252 927	Electrolytic 47 μ F/10V	CE04W1A470M(SME)
C111	257 0012 966	Chip Ceramic 0.01 μ F/50V	CK73F1H103Z	C167	257 0006 943	Chip Ceramic 560 pF/50V	CC73SL1H561J
C112	257 0002 921	Chip Ceramic 10 pF/50V	CC73SL1H100D	C168	254 4252 927	Electrolytic 47 μ F/10V	CE04W1A470M(SME)
C113	257 0003 946	Chip Ceramic 33 pF/50V	CC73SL1H330J	C169,170	257 0003 933	Chip Ceramic 30 pF/50V	CC73SL1H300J
C114	254 4260 964	Electrolytic 3.3 μ F/50V	CE04W1H3R3M(SME)	C171	257 0012 966	Chip Ceramic 0.01 μ F/50V	CK73F1H103Z
C115	254 3056 933	Electrolytic 3.3 μ F/50V (Bipole)	CE04D1H3R3MBP (SME)	C172	254 4252 927	Electrolytic 47 μ F/10V	CE04W1A470M(SME)
C116	257 0007 900	Chip Ceramic 1000 pF/50V	CC73SL1H102J	C601,602	255 1264 937	Plastic Film 1800 pF/50V	CQ93M1H182J(B)
C117	257 0009 982	Chip Ceramic 6800 pF/50V	CK73B1H682K	C603~606	255 1265 978	Plastic Film 0.022 μ F/50V	CQ93M1H223J(B)
C118	257 1013 977	Chip Ceramic 0.068 μ F/25V	CK73B1E683K	C607,608	254 4260 948	Electrolytic 1 μ F/50V	CE04W1H010M(SME)
C120	254 4254 909	Electrolytic 10 μ F/16V	CE04W1C100M(SME)	C609~612	257 0005 944	Chip Ceramic 220 pF/50V	CC73SL1H221J
C121	254 4260 964	Electrolytic 3.3 μ F/50V	CE04W1H3R3M(SME)	C613,614	254 4254 909	Electrolytic 10 μ F/16V	CE04W1C100M(SME)
C122	254 4258 905	Electrolytic 4.7 μ F/35V	CE04W1V4R7M(SME)	C615,616	257 0012 966	Chip Ceramic 0.01 μ F/50V	CK73F1H103Z
C123	257 0012 982	Chip Ceramic 0.022 μ F/50V	CK73F1H223Z	OTHER GROUP			
C125	257 0012 982	Chip Ceramic 0.022 μ F/50V	CK73F1H223Z			(P.W.Board)	Qty
C126	254 4254 938	Electrolytic 47 μ F/16V	CE04W1C470M(SME)	X101	399 0075 003	Crystal(7.2 MHz)	(1)
C127	257 0007 900	Chip Ceramic 1000 pF/50V	CC73SL1H102J	X102	399 0178 007	Crystal(4.332 MHz)	1
C128	257 0012 966	Chip Ceramic 0.01 μ F/50V	CK73F1H103Z	CF101	261 0141 001	FM Ceramic Filter	SK107M2-A0-20 1
C129	257 0012 982	Chip Ceramic 0.022 μ F/50V	CK73F1H223Z	CF102	261 0142 000	FM Ceramic Filter	SK107M3-A0-20 1
C130	257 0003 933	Chip Ceramic 30 pF/50V	CC73SL1H300J	CF104	261 0101 009	AM Ceramic Filter	BFU450C4N 1
C131	257 0002 992	Chip Ceramic 20 pF/50V	CC73SL1H200J	CF105	261 0103 007	Ceramic Resonator	CSB456F11 1
C132	257 0012 966	Chip Ceramic 0.01 μ F/50V	CK73F1H103Z	CF107	399 0041 901	Ceramic Resonator	CSA4.00MG 1
C133	257 0012 982	Chip Ceramic 0.022 μ F/50V	CK73F1H223Z	T101	231 2909 004	FM IF Det.	1
C134	254 3056 917	Electrolytic 1 μ F/50V (Bipole)	CE04D1H010MBP (SME)	T103	231 3904 008	AM IFT	1
C135	257 0012 966	Chip Ceramic 0.01 μ F/50V	CK73F1H103Z	T104	231 1913 004	MW Ant-Osc. Coil	1
C136	254 4254 938	Electrolytic 47 μ F/16V	CE04W1C470M(SME)	LP101	232 9010 009	Antibirdie Filter	1
C137	254 4254 941	Electrolytic 100 μ F/16V	CE04W1C101M(SME)	LP102,103	232 9011 008	Low Pass Filter	1
C138	257 0012 966	Chip Ceramic 0.01 μ F/50V	CK73F1H103Z	FE101	216 9013 004	FM Front End(U)	1
C139	254 4252 930	Electrolytic 100 μ F/10V	CE04W1A101M(SME)				
C140,141	257 0016 933	Chip Ceramic 15 pF/50V	CC73CH1H150J				
C142	257 0012 966	Chip Ceramic 0.01 μ F/50V	CK73F1H103Z				

RECEIVER SECTION

Ref. No.	Part No.	Part Name	Remarks	Qty
JK101	205 0847 004	3 P Ant. Terminal(PAL/F)		1
RM301	499 0150 008	Remocon Sensor	SBX1610-52	1
	212 5604 907	Tact Switch		13
HP701	204 8370 020	Head Phone Jack(D3.6)		1
CN101	205 0805 059	11 P Conn. Socket(9176)		1
CN102	205 0987 003	12 P Conn. Socket(9176)		1
CN503	203 8211 092	5 P KR-DA Conn. Cord		1
CN601	203 4632 028	3 P KR-DA Conn. Cord		1
CN702	203 8346 022	5 P EH-SCN Conn. Cord		1
CT001,003	009 9037 013	1 P Wire Ass'y		2

RECEIVER SECTION

KU-9332 PARTS LIST

Ref. No.	Part No.	Part Name	Remarks	Ref. No.	Part No.	Part Name	Remarks
SEMICONDUCTORS GROUP				D441,442	276 0553 905	Diode 1SR35-200A	
IC401	263 1010 001	IC BA178M06		D472	276 0616 907	Diode 1SS252	
IC403	263 1004 004	IC BA178M12		D479,480	276 0616 907	Diode 1SS252	
IC404	262 1887 008	IC HD6433726A17F		D601,602	276 0616 907	Diode 1SS252	
IC440	262 0150 914	IC TLP181(BL/GR)		D604	276 0616 907	Diode 1SS252	
IC501	263 1032 908	IC NJM2082MD		D651,652	276 0616 907	Diode 1SS252	
IC502	262 1227 008	IC LC7821		D702~704	276 0616 907	Diode 1SS252	
IC506	263 0615 902	IC BA15218F		D706	276 0616 907	Diode 1SS252	
IC602,603	263 0615 902	IC BA15218F		D708	276 0616 907	Diode 1SS252	
IC604	263 0905 900	IC BA6208F		△D711	276 0338 007	Diode S4VB20F	Bridge
IC605,606	262 0150 914	IC TLP181(BL/GR)		D712,713	276 0553 905	Diode 1SR35-200A	
IC701	265 0073 003	IC STK4152MK2		D715~718	276 0553 905	Diode 1SR35-200A	
IC702	263 0646 007	IC M5230L		D719	276 0644 966	Zener Diode MTZJ12A	
TR403	273 0388 906	Transistor 2SC1740S(E)		△R447	244 2050 933	Metal Oxide 180 ohm	RS14B3A181JNBS
TR440	274 0120 002	Transistor 2SD1762(E/F)		△R448,449	244 2051 987	Metal Oxide 4.7 ohm	RS14B3A4R7JNBS
TR407,408	269 0020 906	Transistor DTC114ES (10K-10K)	Built in Resistor	R501,502	247 0009 901	Chip Carbon 4.7 kohm 1/10W	RM73B--472J
TR409	274 0120 002	Transistor 2SD1762(E/F)		R503,504	247 0011 957	Chip Carbon 51 kohm 1/10W	RM73B--513J
TR411	269 0075 906	Transistor DTC124TS(22K)	Built in Resistor	R505,506	247 0006 975	Chip Carbon 510 ohm 1/10W	RM73B--511J
TR412	269 0020 906	Transistor DTC114ES (10K-10K)	Built in Resistor	R507,508	247 0013 926	Chip Carbon 270 kohm 1/10W	RM73B--274J
TR413,414	269 0075 906	Transistor DTC124TS(22K)	Built in Resistor	R509,510	247 0010 961	Chip Carbon 22 kohm 1/10W	RM73B--223J
TR415,416	269 0145 904	Transistor DTC124GS(TP)	Built in Resistor	R511,512	247 0013 984	Chip Carbon 470 kohm 1/10W	RM73B--474J
TR422	269 0020 906	Transistor DTC114ES (10K-10K)	Built in Resistor	R513,514	247 0005 905	Chip Carbon 100 ohm 1/10W	RM73B--101J
TR441	269 0046 906	Transistor DTC114ES (10K-10K)	Built in Resistor	R569,570	247 0012 927	Chip Carbon 100 kohm 1/10W	RM73B--104J
TR504,505	269 0099 908	Transistor DTC143TS(4.7K)	Built in Resistor	R571,572	247 0006 962	Chip Carbon 470 ohm 1/10W	RM73B--471J
TR506	269 0093 904	Transistor DTA144ES (47K-47K)	Built in Resistor	R575,576	247 0012 927	Chip Carbon 100 kohm 1/10W	RM73B--104J
TR601,602	275 0058 902	FET 2SJ40(C)/(D)		R577,578	247 0006 962	Chip Carbon 470 ohm 1/10W	RM73B--471J
TR605,606	269 0046 906	Transistor DTA114ES (10K-10K)	Built in Resistor	R585,586	247 0013 984	Chip Carbon 470 kohm 1/10W	RM73B--474J
TR702	273 0432 904	Transistor 2SC2389STP(S/E)		R587~590	247 0012 927	Chip Carbon 100 kohm 1/10W	RM73B--104J
TR703	269 0020 906	Transistor DTC114ES (10K-10K)	Built in Resistor	R623,624	247 0012 927	Chip Carbon 100 kohm 1/10W	RM73B--104J
TR704,705	273 0388 906	Transistor 2SC1740S(E)		R627,628	247 0012 927	Chip Carbon 100 kohm 1/10W	RM73B--104J
TR706	271 0192 905	Transistor 2SA933S(S)		R629,630	247 0009 901	Chip Carbon 4.7 kohm 1/10W	RM73B--472J
TR707	274 0120 002	Transistor 2SD1762(E/F)		R631,632	247 0006 920	Chip Carbon 3.3 kohm 1/10W	RM73B--332J
TR708	272 0107 919	Transistor 2SB1328(P/Q)		R633,634	247 0012 901	Chip Carbon 82 kohm 1/10W	RM73B--823J
TR709	269 0020 906	Transistor DTC114ES (10K-10K)	Built in Resistor	R635	247 0012 927	Chip Carbon 100 kohm 1/10W	RM73B--104J
TR714	269 0020 906	Transistor DTC114ES (10K-10K)	Built in Resistor	R636	247 0009 927	Chip Carbon 5.6 kohm 1/10W	RM73B--562J
D411	276 0616 907	Diode 1SS252		R651,652	247 0011 944	Chip Carbon 47 kohm 1/10W	RM73B--473J
D417,418	276 0553 905	Diode 1SR35-200A		R659	247 0018 905	Chip Carbon 0 ohm 1/10W	RM73B--0R0K
D419	276 0645 923	Zener Diode MTZJ22A		△R709,710	241 2377 947	Carbon Film 100 ohm 1/4W(NB)	RD14B2E101JNBS
D421~428	276 0636 903	Zener Diode MTZJ8.2B		△R717,718	244 2051 987	Metal Oxide 4.7 kohm	RS14B3A4R7JNBS
D429	276 0616 907	Diode 1SS252		△R721,722	244 2043 982	Metal Oxide 0.22 ohm	RS14B3AR22JNBS
D431	276 0616 907	Diode 1SS252		△R753,754	241 2379 929	Carbon Film 650 ohm 1/4W(NB)	RD14B2E651JNBS
D432	276 0634 905	Zener Diode MTZJ3.3A		△R765	244 2050 933	Metal Oxide 180 ohm	RS14B3A181JNBS
D440	276 0644 908	Zener Diode MTZJ6.8A		△R766	244 2051 958	Metal Oxide 220 ohm	RS14B3A221JNBS
				△R995	241 2377 947	Carbon Film 100 ohm 1/4W(NB)	RD14B2E101JNBS

RECEIVER SECTION

Ref. No.	Part No.	Part Name	Remarks	Ref. No.	Part No.	Part Name	Remarks	Qty
CAPACITORS GROUP								
C001,002	253 1181 904	Chip Ceramic 0.01 μ F/50V	CK45F1H103Z(DD-3)	L501,502	235 9003 002	Inductor		2
C409	253 1181 904	Chip Ceramic 0.01 μ F/50V	CK45F1H103Z(DD-3)	L701,702	235 0007 007	Inductor		2
C411	254 4254 941	Electrolytic 100 μ F/16V	CE04W1C101M(SME)	Δ T002	239 8019 002	Line Filter Coil		1
C413	253 9037 908	Chip Ceramic 0.1 μ F/50V	CK45=1H104Z(BC)	RL701	214 0167 005	Relay(G5Z-2A)		1
C414	254 4254 909	Electrolytic 10 μ F/16V	CE04W1C100M(SME)	X402	399 0191 903	Ceramic Resonator	CST4.00MGW	1
C415	253 1181 904	Chip Ceramic 0.01 μ F/50V	CK45F1H103Z(DD-3)	Δ F001~005	206 1075 001	Fuse(1A)		5
C419	253 1181 904	Chip Ceramic 0.01 μ F/50V	CK45F1H103Z(DD-3)	JK501	205 0754 003	6 P Pin Jack (GND)		1
C420	254 2452 930	Electrolytic 100 μ F/10V	CE04W1A101M(SME)	JK502	204 8519 001	4 P Pin Jack (GND)		1
C421	259 0007 702	Super Capacitor 8200 μ F/5.5V	SB CAP=-822=C	JK701	205 0551 002	4 P Terminal		1
C422	253 1181 904	Chip Ceramic 0.01 μ F/50V	CK45F1H103Z(DD-3)	417 9050 000	Radiator		1	
C423	254 2452 930	Electrolytic 100 μ F/10V	CE04W1A101M(SME)	473 7500 015	Tapping Screw(P) 3 \times 8		2	
C424	254 4252 969	Electrolytic 470 μ F/10V	CE04W1A471M(SME)	417 0114 000	Radiator		1	
C425	254 4254 909	Electrolytic 10 μ F/16V	CE04W1C100M(SME)	473 7500 015	Tapping Screw(P) 3 \times 8		1	
C426	253 1181 904	Chip Ceramic 0.01 μ F/50V	CK45F1H103Z(DD-3)	CN501	205 0805 017	3 P Conn. Socket		1
C431	254 4258 905	Electrolytic 4.7 μ F/35V	CE04W1V4R7M(SME)	CN502	205 0987 029	13 P Conn. Socket(9176)		1
C432	253 1181 904	Chip Ceramic 0.01 μ F/50V	CK45F1H103Z(DD-3)	CN602	205 0355 033	3 P KR Conn. Base(L)		1
C433,434	254 1193 934	Chip Ceramic 100 pF/50V	CK14B1H101K	CN603	203 5133 005	3 P KR-DA Shield Cord		1
C440	254 4254 941	Electrolytic 100 μ F/16V	CE04W1C101M(SME)	CN605	203 6214 017	4 P KR-DA Conn. Cord		1
C441	254 4254 789	Electrolytic 1000 μ F/16V	CE04W1C102M(SME)	Δ CB001	203 2349 009	2 P Inlet		1
C442	254 4254 941	Electrolytic 100 μ F/16V	CE04W1C101M(SME)	Δ CB002	205 0453 003	2 P VH Conn. Base(L)		1
C501,502	257 0005 944	Chip Ceramic 220 pF/50V	CC73SL1H221J	CB003	205 0190 065	6 P NH Connector Base		1
C503,504	254 4254 909	Electrolytic 10 μ F/16V	CE04W1C100M(SME)	CB005	205 0190 036	3 P NH Connector Base		1
C505,506	254 4252 927	Electrolytic 47 μ F/10V	CE04W1A470M(SME)	CB101	205 0806 058	11 P Conn. Base(9115)		1
C511,512	254 4254 909	Electrolytic 10 μ F/16V	CE04W1C100M(SME)	CB102	205 0988 002	12 P Conn. Base(9115)		1
C513,514	257 0012 966	Chip Ceramic 0.01 μ F/50V	CK73F1H103Z	CB301				
C529,530	253 4444 907	Chip Ceramic 220 pF/50V	CC45SL1H221J	CB401	204 8284 022	15 P System Socket		1
C571~574	257 0005 902	Chip Ceramic 180 pF/50V	CC73SL1H181J	CB402	205 0730 056	13 P System Socket(BU)		1
C581,582	254 4258 905	Electrolytic 4.7 μ F/35V	CE04W1V4R7M(SME)	CB501	205 0806 016	3 P Conn. Base		1
C583,584	257 0005 902	Chip Ceramic 150 pF/50V	CC73SL1H151J	CB502	205 0988 028	13 P Conn. Base(9115)		1
C585,586	254 4254 909	Electrolytic 10 μ F/16V	CE04W1C100M(SME)	CB503	205 0343 058	5 P Conn. Base		1
C587,588	257 0012 966	Chip Ceramic 0.01 μ F/50V	CK73F1H103Z	CB603	205 0343 032	3 P Conn. Base(KR-PH)		1
C621,622	254 4258 905	Electrolytic 4.7 μ F/35V	CE04W1V4R7M(SME)	CB605	205 0355 046	4 P KR Conn. Base(L)		1
C623~626	257 0005 986	Chip Ceramic 330 pF/50V	CC73SL1H331J	CB702	205 0233 058	5 P EH Connector Base		1
C627,628	257 0005 986	Chip Ceramic 330 pF/50V	CC73SL1H331J	412 9483 009	Earth Plate		1	
C631,632	254 4260 922	Electrolytic 0.33 μ F/50V	CE04W1HR33M(SME)	009 9043 007	1 P Wire Ass'y		1	
C633,634	254 4254 909	Electrolytic 10 μ F/16V	CE04W1C100M(SME)	205 0452 017	Style Pin		3	
C637,638	257 0012 966	Chip Ceramic 0.01 μ F/50V	CK73F1H103Z					
C651	257 0012 966	Chip Ceramic 0.01 μ F/50V	CK73F1H103Z					
C652	253 4444 907	Chip Ceramic 220 pF/50V	CC45SL1H221J					
C717,718	256 1034 937	Metarized 0.047 μ F/50V	CF93A1H473J					
C720	254 4250 945	Electrolytic 330 μ F/6.3V	CE04W0J331M(SME)					
C707,708	254 4252 901	Electrolytic 22 μ F/10V	CE04W1A220M(SME)					
C751,752	254 4424 700	Electrolytic 4700 μ F/45V	CE04W==472M					
C755	254 4258 905	Electrolytic 4.7 μ F/35V	CE04W1V4R7M(SME)					
C769,770	254 4258 905	Electrolytic 4.7 μ F/35V	CE04W1V4R7M(SME)					
OTHER GROUP								
		(P.W.Board)						(1)
L401,402	235 0060 950	Inductor(10 μ H)						2

REMOTE CONTROL UNIT (RC-800 : Part No. 499 9010 000)

RECEIVER SECTION

● SCHEMATIC DIAGRAM

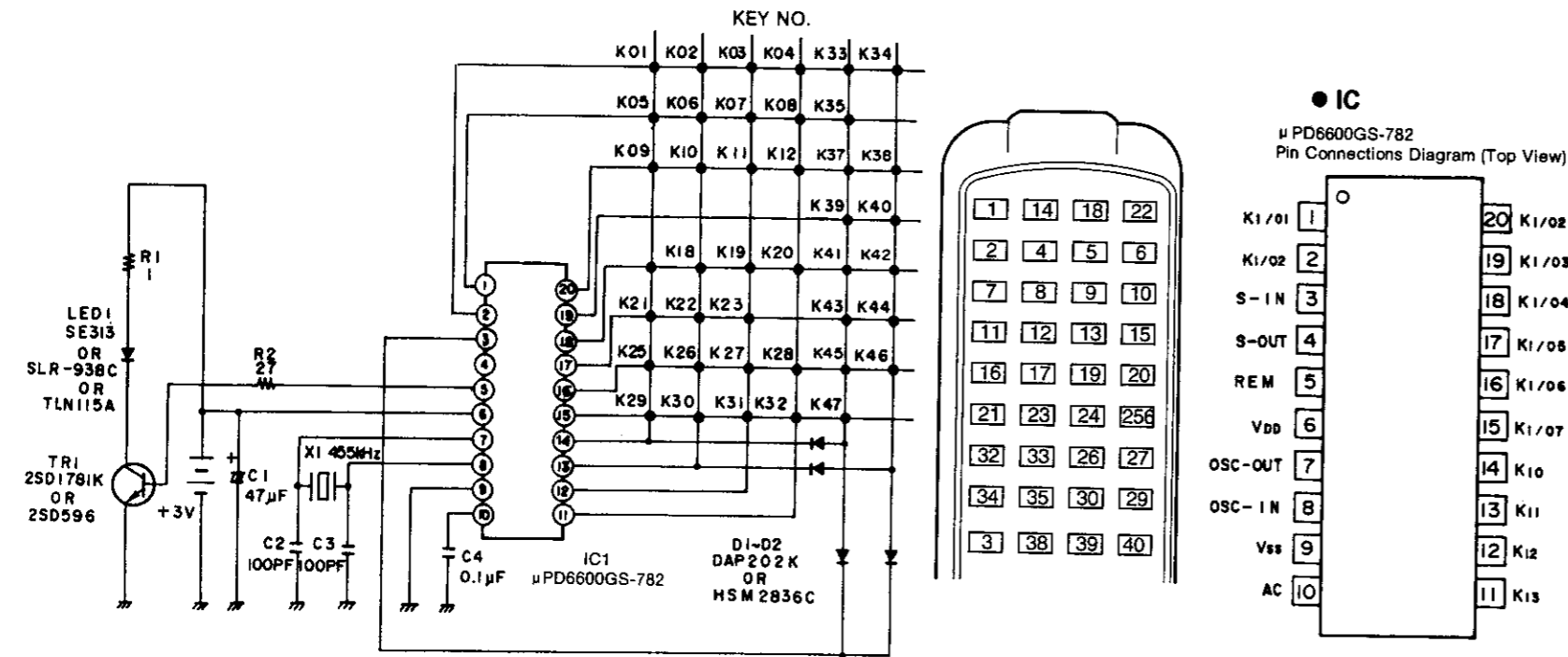

KEY POSITION	KEY NO.	FUNCTION	C ₁	D1	C ₁₅	C ₁	D2	C ₁₅	KEY POSITION	KEY NO.	FUNCTION	C ₁	D1	C ₁₅	C ₁	D2	C ₁₅
1	K05	POWER		001100000101000		Same as left.			21	K33	9		001101100011000		000100101001000		
2	K07	SLEEP		001100100111000		Same as left.			22	K38	CANCEL		000101000101000		Same as left.		
3	K06	FUNCTION		001101111101000		Same as left.			23	K34	10		001100010011000		000101101001000		
4	K46	■		000100111101000		Same as left.			24	K35	+10		001101111011000		000100011001000		
5	K44	▶		000100011101000		Same as left.			25	K10	BAND		001101110101100		Same as left.		
6	K45			000101011101000		Same as left.			26	K12	TUNING ▼		001100101101100		Same as left.		
7	K43	◀◀		000101101101000		Same as left.			27	K11	TUNING ▲		001101001101100		Same as left.		
8	K42	▶▶		000100101101000		Same as left.			28	K09	CT		001101100101100		Same as left.		
9	K41	◀◀◀		000101001101000		Same as left.			29	K08	RDS		001100100101100		Same as left.		
10	K40	▶▶▶		000100001101000		Same as left.			30	K04	PRESET ▼		001101110010000		Same as left.		
11	K25	1		001100100001000		000100100001000			31	K03	PRESET ▲		001100111001000		Same as left.		
12	K26	2		001101100001000		000101100001000			32	K18	◀		001001110011000		Same as left.		
13	K27	3		001100010001000		000100010001000			33	K21	▶		001000011011000		Same as left.		
14	K39	DIRECT		000101110101000		Same as left.			34	K20	◀◀		001001101011000		Same as left.		
15	K28	4		001101010001000		000101010001000			35	K19	▶▶		001000101011000		Same as left.		
16	K29	5		001100110001000		000100110001000			36	K22	■		001000111011000		Same as left.		
17	K30	6		001101110001000		000101110001000			37	K23	● REC		001001111011000		Same as left.		
18	K37	PROGRAM		000101011001000		Same as left.			38	K47	SDB		000100101011100		Same as left.		
19	K31	7		001100001001000		000100001001000			39	K01	VOLUME ▼		001100011001000		Same as left.		
20	K32	8		001101001001000		000101001001000			40	K02	VOLUME ▲		001101011001000		Same as left.		

* D1: Tune mode (After sending the BAND (K10) key and the initial condition immediately following battery insertion.)
 D2: TCD mode (After sending the DIRECT (K39) key or the PROGRAM (K37) key.)

NOTE:

1. Unspecified resistance values are in ohm, K indicates kohm, and M indicates Mohm.
2. Unspecified capacitance values are in μ F, p indicates pF.
3. The voltages of the various section represent the values when there is no signal.
4. This wiring diagram is the basic wiring diagram. Note that it may be changed for the purpose of improvement, etc.

BLOCK DIAGRAM

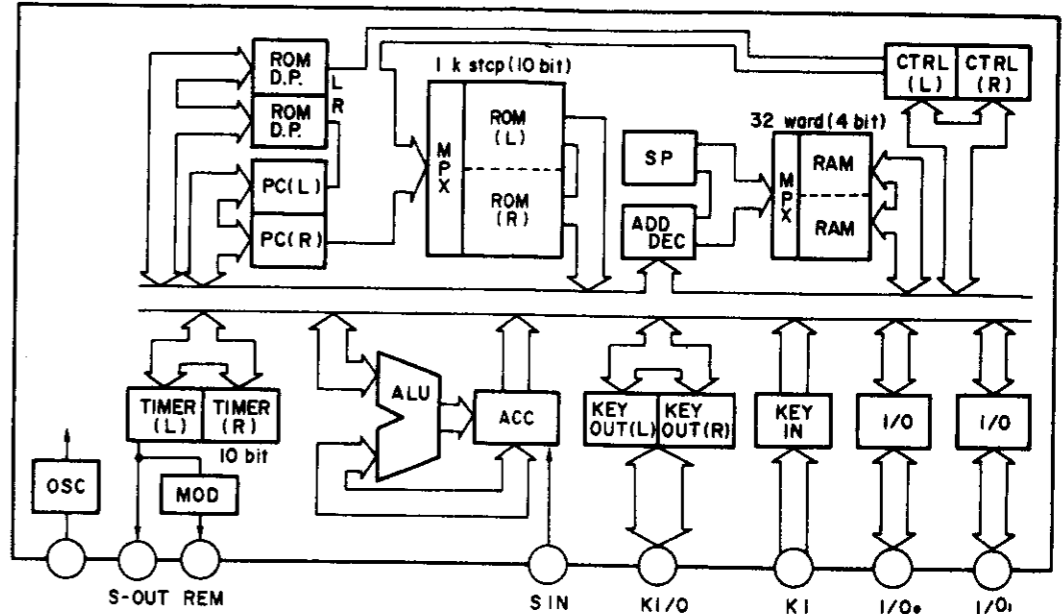

● Transistors

2SD1781K
or
2SD596

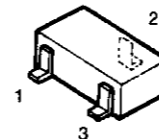

- 1 B (Base)
- 2 C (Collector)
- 3 E (Emitter)

● Diodes

Infrared LED
SE313
SLR-938C
TLN115A



- Short (Cathode) Long (Anode)

DAP202K
or
HSM2836CTR

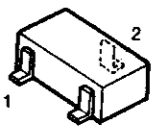

A

B

C

D

E

RECEIVER SECTION

WIRING DIAGRAM

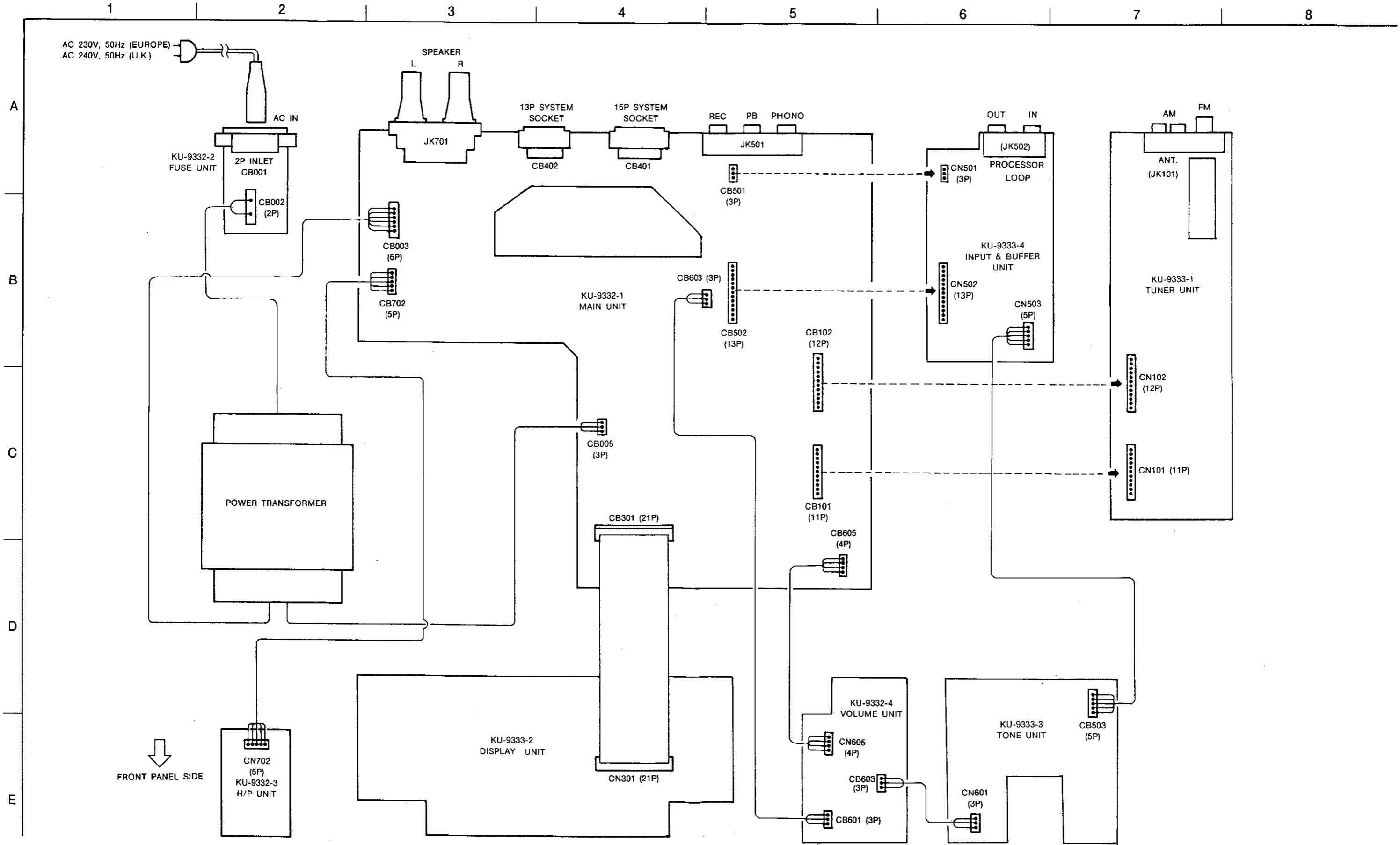

FRONT PANEL SIDE

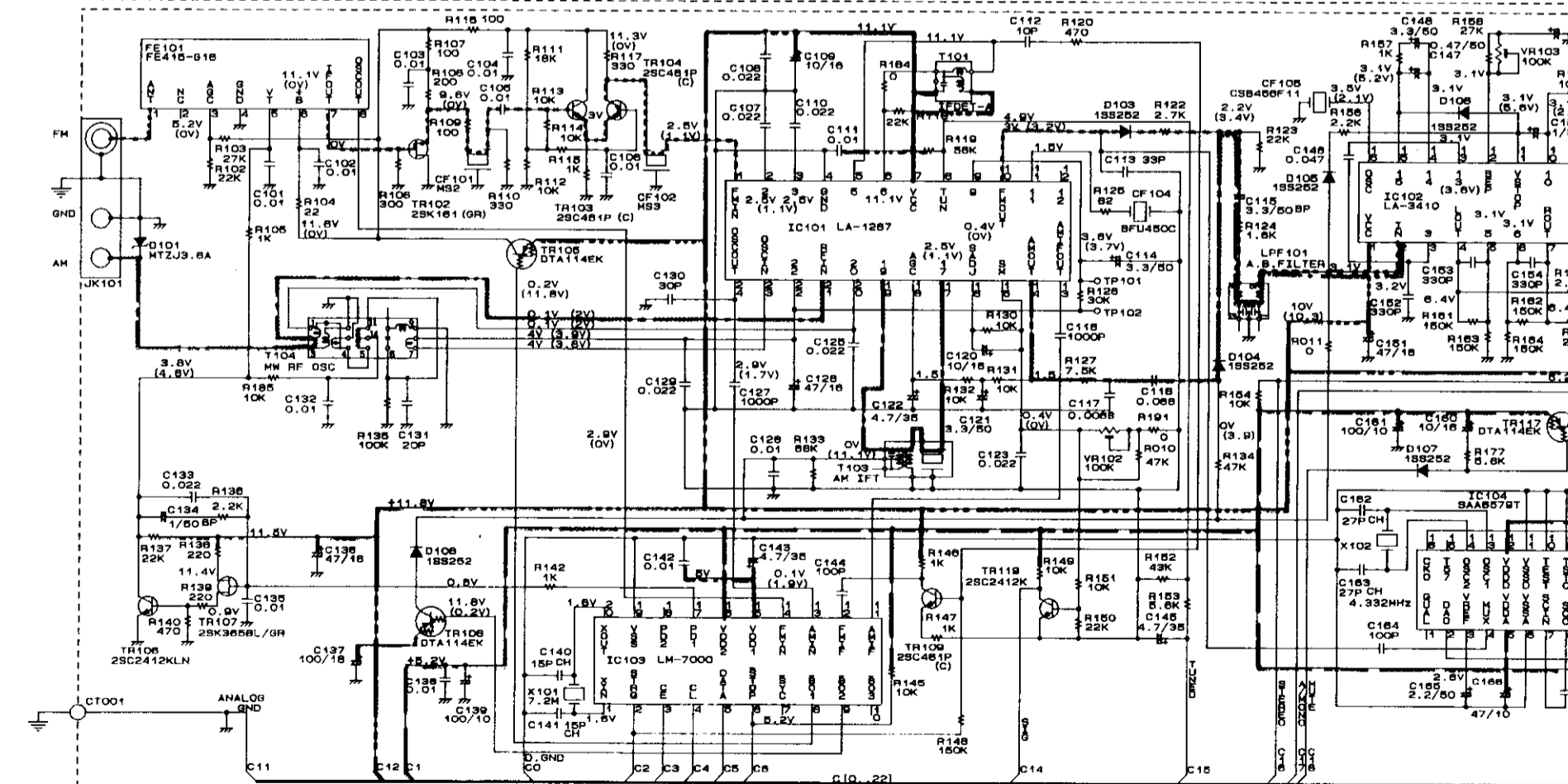
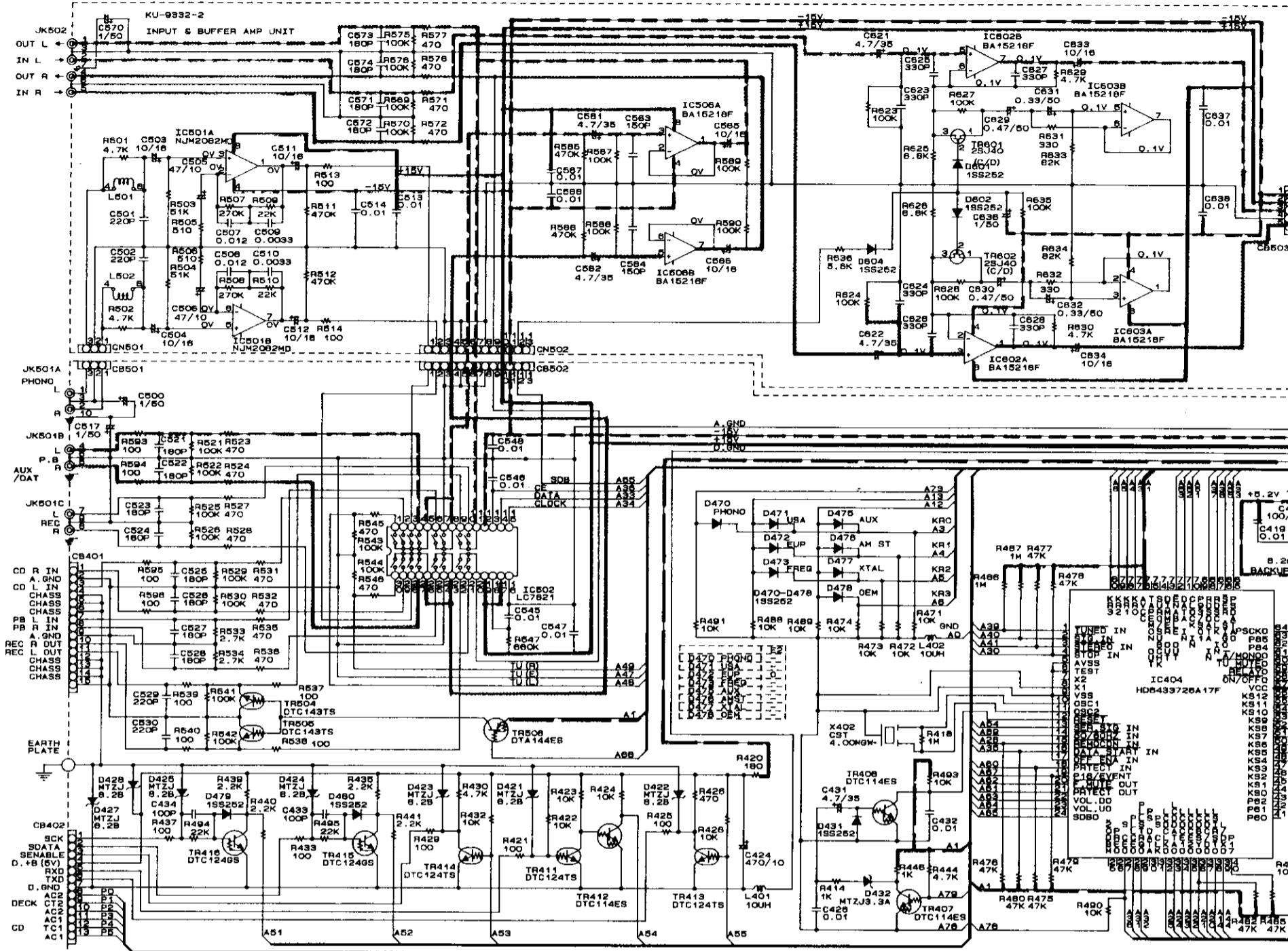

- +15V LINE
- -15V LINE
- +6V LINE
- -12V LINE
- +B LINE
- -B LINE
- R-ch LINE
- L-ch LINE
- AM SIGNAL LINE
- FM SIGNAL LINE

WARNING:
 Parts marked with this symbol have critical characteristics.
 Use ONLY replacement parts recommended by the manufacturer.

CAU
 Bef
 leak
 defe
 WA
 DO

SCHEMATIC DIAGRAM

5

6

7

8

9

10

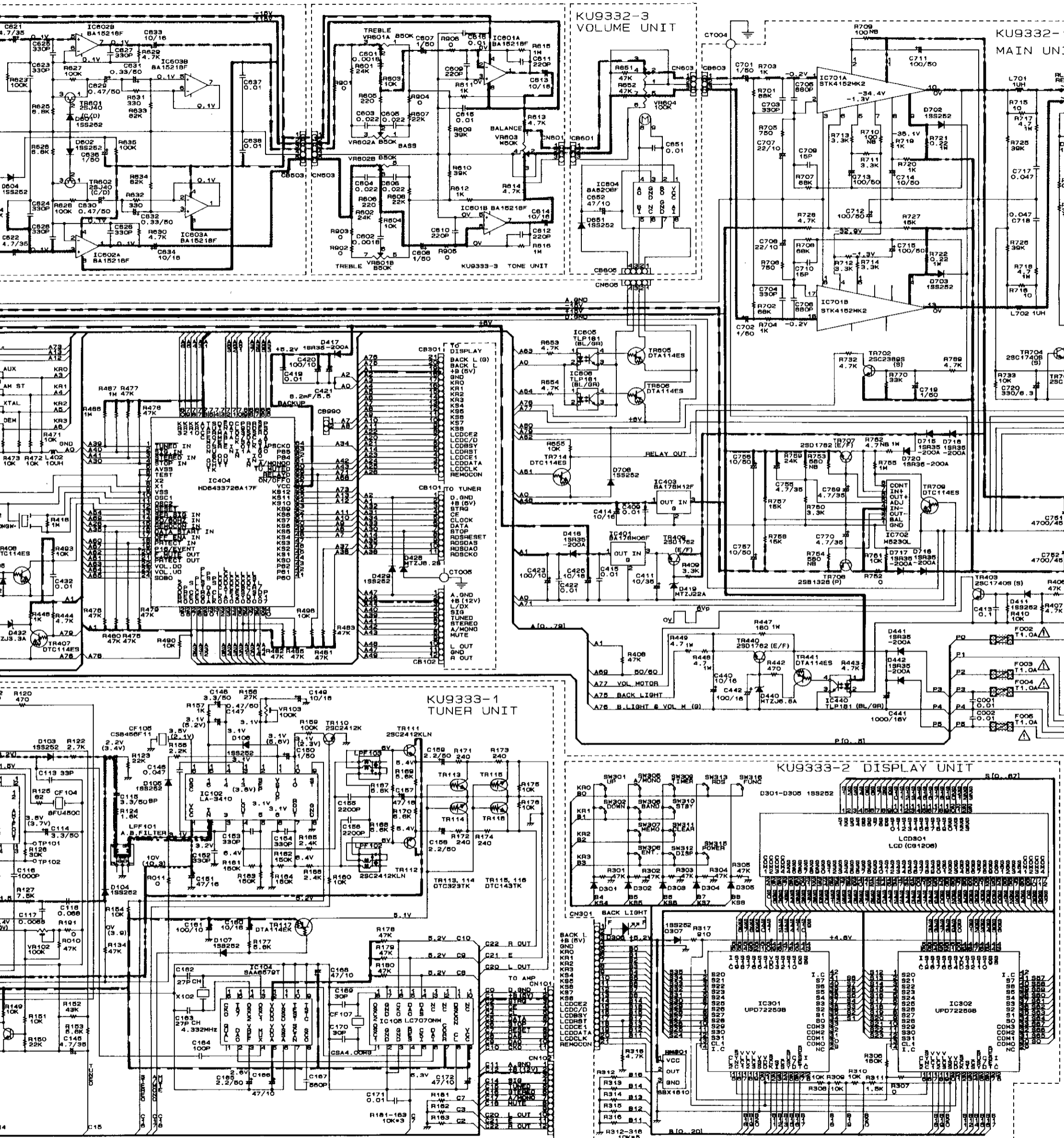

WARNING: Components marked with this symbol have critical characteristics. Only replacement parts recommended by the manufacturer.

CAUTION: Before returning the unit to the customer, make sure you make either (1) a leakage current check or (2) a line to chassis resistance check. If the leakage current exceeds 0.5 milliamps, or if the resistance from chassis to either side of the power cord is less than 240 Kohms, the unit is defective.

WARNING: DO NOT return the unit to the customer until the problem is located and corrected.

NOTES: ALL RESISTANCE VALUES IN OHM M... ALL CAPACITANCE VALUES IN MICRO... EACH VOLTAGE PART AND CURRENT ARE SUBJECT TO CHANGE WITHOUT NOTICE.

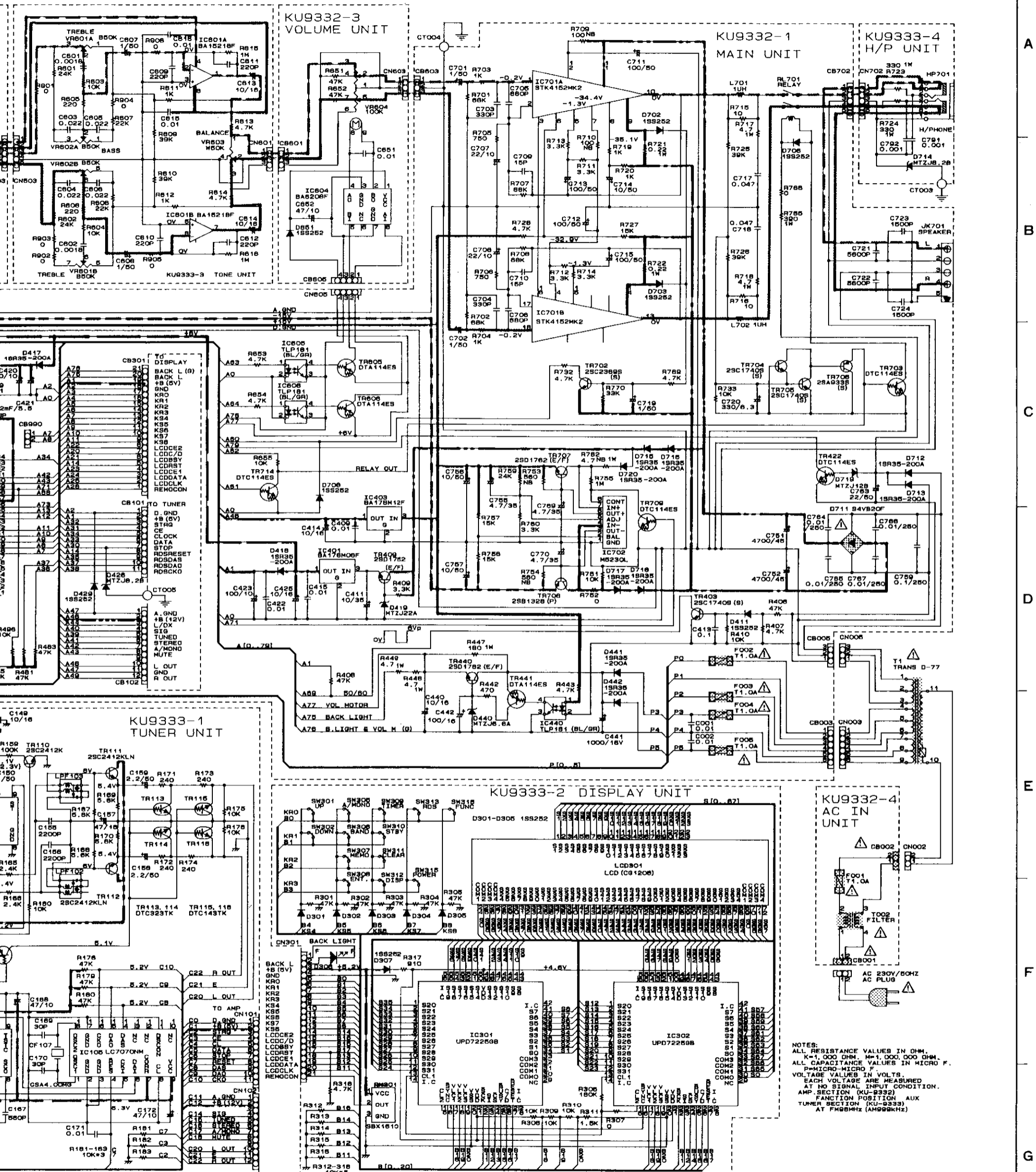

A

B

C

D

E

F

G

CAUTION:
 Before returning the unit to the customer, make sure you make either (1) a leakage current check or (2) a line to chassis resistance check. If the leakage current exceeds 0.5 milliamperes, or if the resistance from chassis to either side of the power cord is less than 240 Kohms, the unit is defective.

WARNING:
 Do NOT return the unit to the customer until the problem is located and corrected.

NOTES:
 ALL RESISTANCE VALUES IN OHM K=1,000 OHM M=1,000,000 OHM
 ALL CAPACITANCE VALUES IN MICRO FARAD P=MICRO-MICRO FARAD
 EACH VOLTAGE AND CURRENT ARE MEASURED AT NO SIGNAL INPUT CONDITION.
 CIRCUIT AND PARTS ARE SUBJECT TO CHANGE WITHOUT PRIOR NOTICE.

H

RECEIVER SECTION

PARTS LIST OF UDRA-77 EXPLODED VIEW

Ref. No.	Part No.	Part Name	Remarks	Qty
1	KU- 9333	Tuner Unit Ass'y		1 ^S
1-1	—	Tuner Unit		(1)
1-2	—	Display Unit		(1)
1-3	—	Tone Unit		(1)
1-4	—	Preamp Unit		(1)
2	393 6006 007	LCD Ass'y(CG1206)	LC301	1
3	216 9013 004	FM Front End(U)		1
4	205 0847 004	3 P Ant. Terminal(PAL/F)		1
5	KU- 9332	Main Unit Ass'y		1 ^S
5-1	—	Main Unit		(1)
5-2	—	AC IN Unit		(1)
5-3	—	Headphone Unit		(1)
5-4	—	Volume Unit		(1)
6	214 0167 005	Relay(G5Z-2A)		1
7	239 8016 002	Ring Filter Coil	7002	1
8	254 4259 700	Chemicon 2200 μ F/35V	C520,521,518	3
★ 9	211 0805 009	Variable Resistor 100 kohm	VR604	1
10	205 1015 029	Fuse(1A)	F001-005	5
11	499 0150 008	Remote Sensor	SBX1610-52	1
12	211 9105 001	Variable Resistor 50 kohm	Balance(VR603)	1
13	211 9013 003	Variable Resistor 50 kohm	Tone(VR601,602)	2
14	204 8370 020	Headphone Jack(D3.5)	HP701	1
15	201 8519 001	4 P Pin Jack(S-GND)	JK502	1
16	205 0754 003	6 P Pin Jack(S-GND)	JK501	1
17	203 2349 009	2 P Inlet	GB001	1
18	411 9119 329	Main chassis		1
19	412 9366 003	Trans Bracket		1
20	104 0237 308	Foot Ass'y		4
21	417 9076 000	Radiator		1
22	105 9269 008	Rear Panel		1
★ 23	513 9345 000	Blind Label		1
24	412 3548 005	P.W.B. Catcher		3
25	412 9368 108	Shield Cover		1
26	233 4584 009	Power Trans.		1
27	146 9345 101	Inner Panel		1
28	146 9189 009	Window		1
29	113 9322 108	4 G Button		1
30	113 1460 013	Power Knob		1
31	113 9329 004	8 G Button		1
32	113 9234 009	Front Panel		1
33	112 9095 128	Volume Knob Ass'y		1
34	112 0645 166	Knob		3
35	146 9347 206	Side Plate(L)		1
36	146 9346 207	Side Plate(R)		1
37	102 0518 238	Top Cover		1
38	513 9343 109	Caution Label	Put on T. Cover	1
39	412 2814 028	Card Spacer(L=10)		1
40	009 9057 006	21 P FF Cable		1
41	205 0643 004	Short Pin		2
42	205 0730 056	13 P System Socket(Bu)	CB402	1
43	204 0284 022	15 P System Socket	CB401	1
44	205 0551 002	4 P Terminal	JK701	1
SCREWS				
71	473 7004 016	Tapping Screw(S) 4×6		8
72	473 7002 018	Tapping Screw(S) 3×8		6
73	473 7500 015	Tapping Screw(P) 3×8	Black	4
74	477 0064 107	Fixing Screw		12
75	473 7015 005	Tapping Screw(S) 3×6	Black	16
76	473 7508 046	Tapping Screw(P) 3×16	Black	5
77	473 7505 007	Tapping Screw(P) 2.6×8		3
78	477 0262 019	Special Screw		1
79	473 7009 008	FH.Tapping Screw(S) 3×6		2
PACKING & ACCESSORIES (Not included EXPLODED VIEW)				
101	505 0131 050	Cabinet Cover		1
102	503 9291 102	Cushion		1
103	503 9292 005	Top Cushion		1
104	501 9279 102	Master Carton		1
105	GEN 7754	Envelope Sub Ass'y		1 ^S
105-1	505 0283 018	Poly Cover		1
105-2	511 9434 009	Inst. Manual		1
105-3	394 0040 004	Battery(R6P)		1
105-4	206 2108 003	AC Conn. with Plug		1
105-5	231 1914 003	Loop Antenna		1
105-6	395 0023 008	FM Ant. Ass'y		1
105-7	204 6471 002	13 P System Connector		1
105-8	204 6316 015	15 P System Connector		1
105-9	499 9711 009	Remocon	RC-180	1

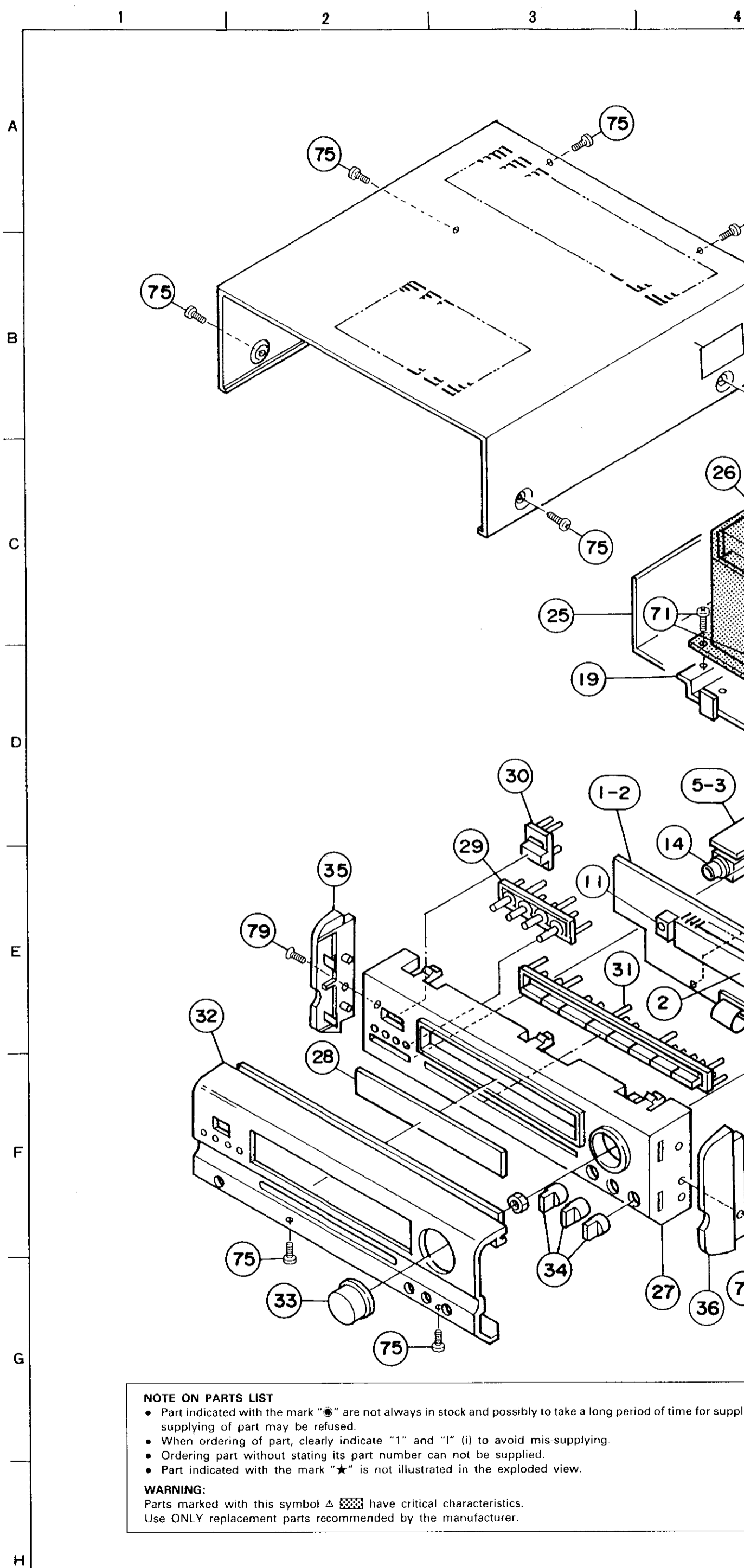

NOTE ON PARTS LIST

- Part indicated with the mark "●" are not always in stock and possibly to take a long period of time for supplying of part may be refused.
- When ordering of part, clearly indicate "1" and "1" (i) to avoid mis-supplying.
- Ordering part without stating its part number can not be supplied.
- Part indicated with the mark "★" is not illustrated in the exploded view.

WARNING:
Parts marked with this symbol have critical characteristics. Use ONLY replacement parts recommended by the manufacturer.

EXPLODED VIEW

3

4

5

6

7

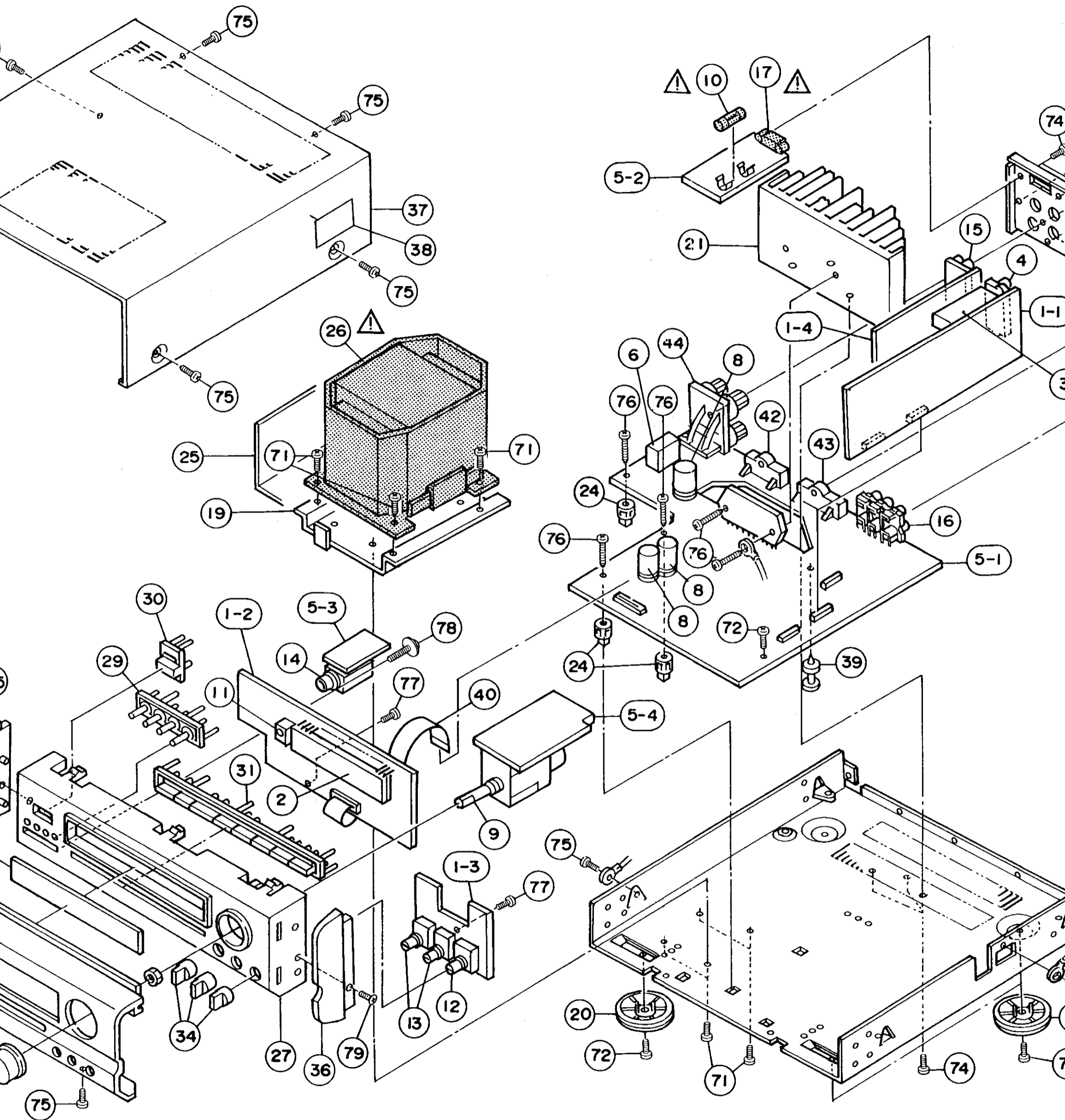

are not always in stock and possibly to take a long period of time for supplying, or in some case
 ed.
 indicate "1" and "1" (i) to avoid mis-supplying.
 part number can not be supplied.
 "r" is not illustrated in the exploded view.

have critical characteristics.
 mended by the manufacturer.

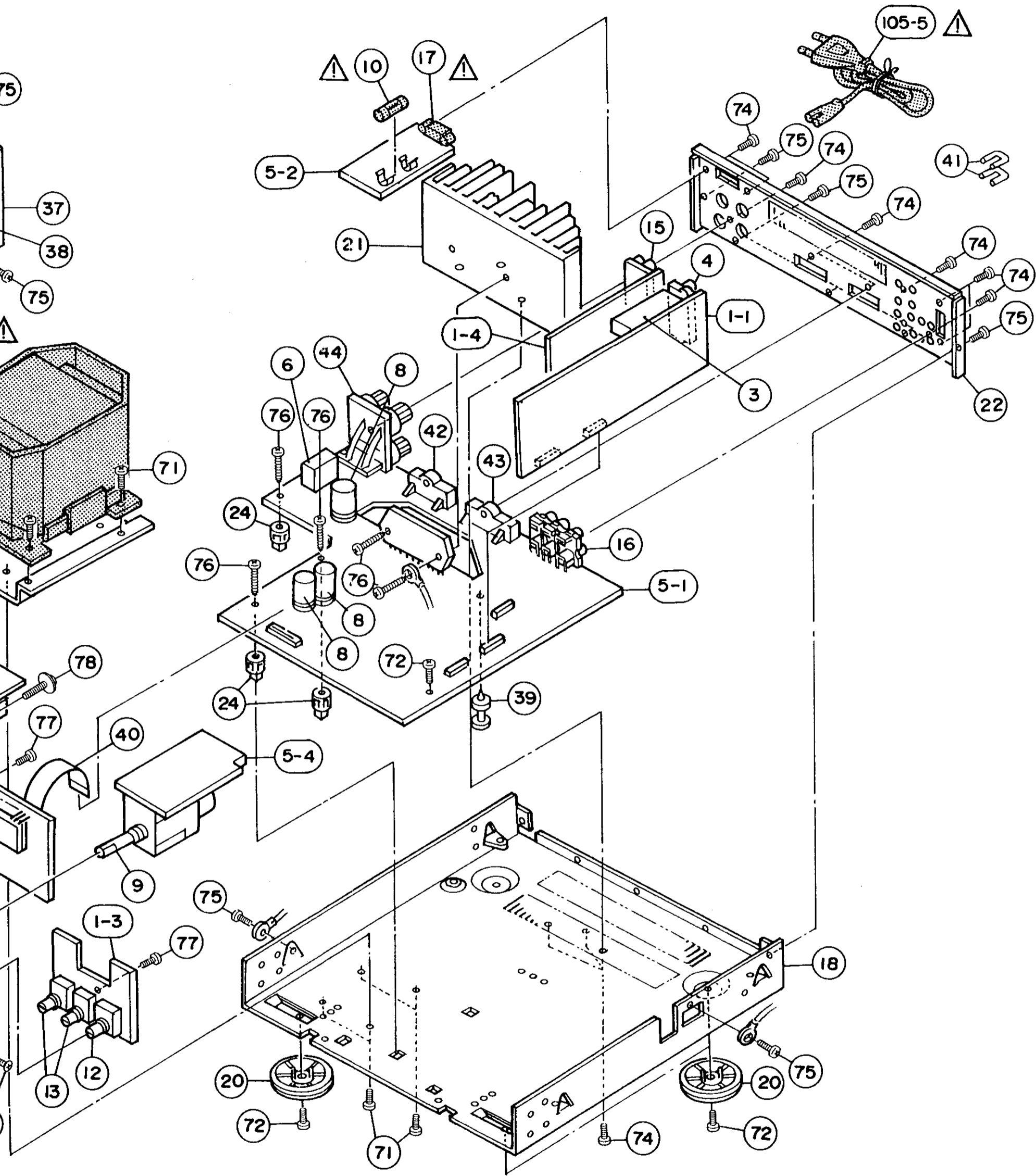

g, or in some case

DISASSEMBLY PROCEDURES

(Follow these procedures in reverse order to reassemble.)

1. Removing the top cover and front panel

- ① Remove the six screws which fasten the top cover.
- ② Remove the two screws of the bottom side which fasten the front panel.

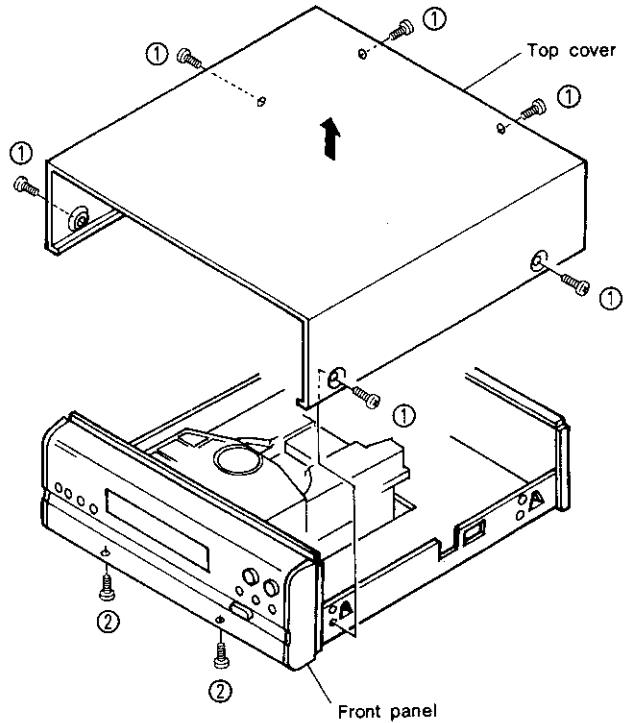

- ③ Disconnect connector CB101(8P), which is attached to the main unit.
 - ④ Remove the 2 screws which fasten the side plate (L), (R).
 - ⑤ While disengaging in the direction of the arrow the tabs of the side plate and the holes of the main chassis (with a flat-bladed screwdriver).
- Use your fingers to push out the hook of the inner panel from the side plate in the direction of the arrow.
- Using the same method for the left side, remove the side plate.
- ⑥ Remove the front panel in the direction of the arrow.

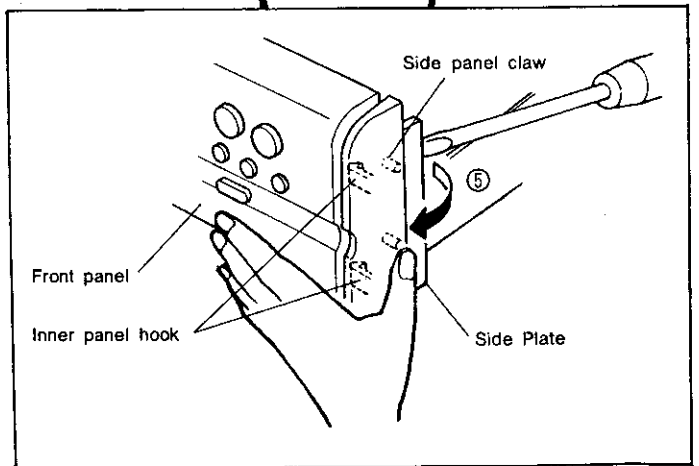
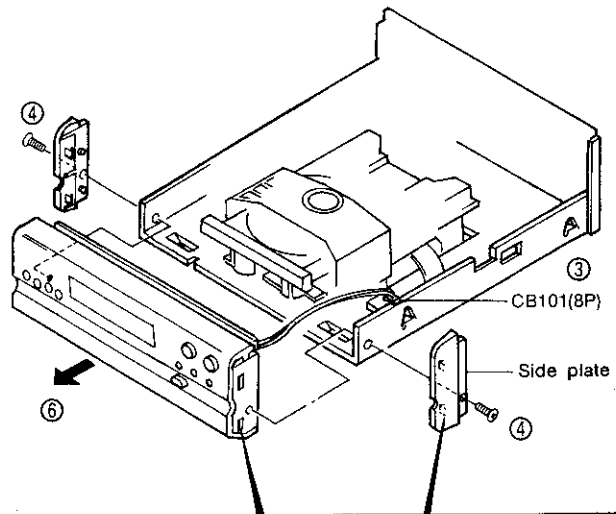

CD PLAYER SECTION

2. Removal of the Various Units

Control Unit (KU-9334-2)

- ① Remove the seven screws which fasten the Control unit and remove the board in the direction of the arrow.
- ② Detach the inner panel hook's catch in the direction of the arrow.

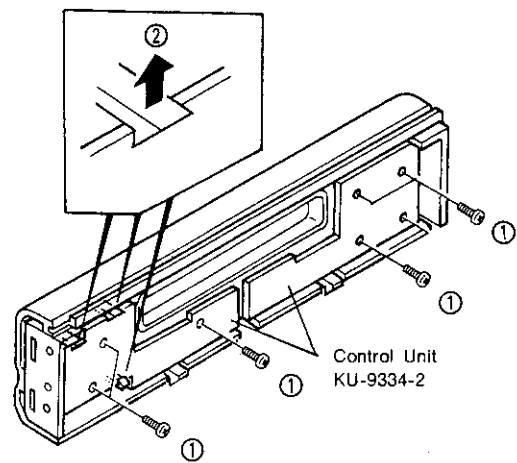

3. Removal of the CD Mechanism Unit

- ③ Disconnect connectors CN204(5P) and CB504(23P) which are attached to the main unit.
- ④ Remove the three screws which fasten the CD mechanism unit and remove the mechanism unit in the direction of the arrow.

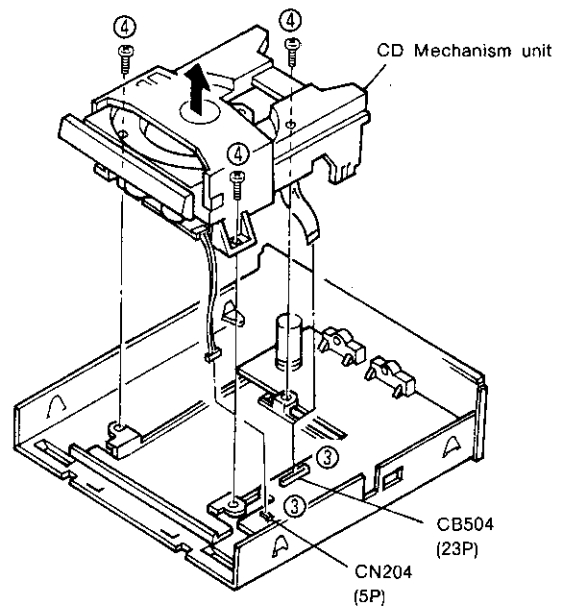

Main Unit (KU-9334-1)

- ⑤ Remove the nine screws which fasten the main unit and remove the board in the direction of the arrow.

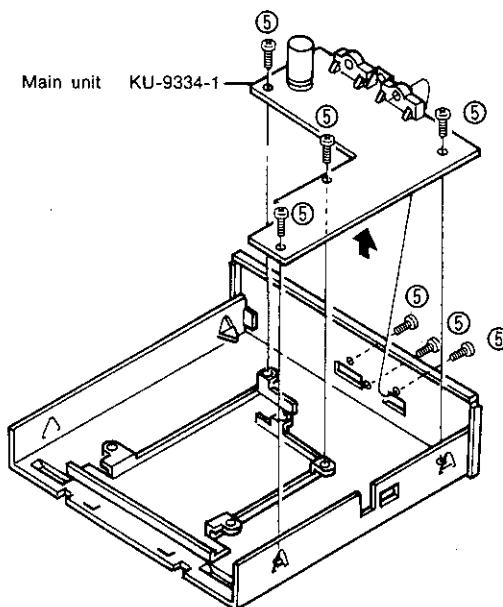

CONFIRMING METHOD OF SERVO

A microcomputer adopted to this unit has the service programs so as to perform confirming more easily with the operation buttons. Digital servo adopted to this unit is became automatic adjustment status in focus gain and tracking gain.

1. Actuating the Service Program

Disconnect 15P system connector of the main unit, and while pressing the ► PLAY and ▲ OPEN/CLOSE buttons at the same time, switch on the system power. The power will be supplied automatically in 2 to 3 seconds, the display of the receiver will indicate " 01 ", and the system will enter the service mode.

NOTE: Once the service program starts the operation buttons cannot be used for normal operation.

2. Operation Function at Service Program Actuation

Button Operation	Operation Function	Explanation
▲ OPEN/CLOSE	Opens or closes disc holder button.	<ul style="list-style-type: none"> • Open or closes only when disc is stopped. • Operate other keys after open or close.
■ STOP	Stops system function.	<ul style="list-style-type: none"> • Displays track number 01. • Press when adjustment completed or do it again.
► PLAY	Starts Focus servo and disc turns when the PLAY button is pushed while track number 01 is displayed.	<ul style="list-style-type: none"> • Push to check the tracking offset. • When completed, displays track number 02 → 03 (02: automatic adjustment).
	Starts Focus servo, Tracking servo, Slide servo and Spindle servo when the PLAY button is pushed while track number 03 is displayed.	<ul style="list-style-type: none"> • Push to check the HF level. • When completed, displays track number 04.
PAUSE	Displays a result of Focus gain automatic adjustment when the PAUSE button is pushed while track number 03 is displayed.	<ul style="list-style-type: none"> • When completed, Display shows: TRACK TIME 1- XX XX TIME display shows automatic adjustment value. Displays: 01 27~00 01 or 00 EE
	Displays a result of Tracking gain automatic adjustment when the PAUSE button is pushed while the result of the automatic focus gain adjustment is displayed.	<ul style="list-style-type: none"> • When completed, Display shows: TRACK TIME 2- XX XX TIME display shows automatic adjustment value. Displays: 01 27~00 01 or 00 EE
Other Buttons	Unable to obtain normal function.	<ul style="list-style-type: none"> • Never attempt to operate the buttons other than the above. • If the buttons are erroneously pressed, promptly turn OFF the power switch.

(Caution)

- During the service program is in operation, do not use remote control.

CD PLAYER SECTION

3. Confirming Method

(1) Required Measuring Equipment

- 1) Dual-trace oscilloscope
- 2) Test disc: CA-1094

(2) Check Point

CD Mechanical unit PWB (pattern view)

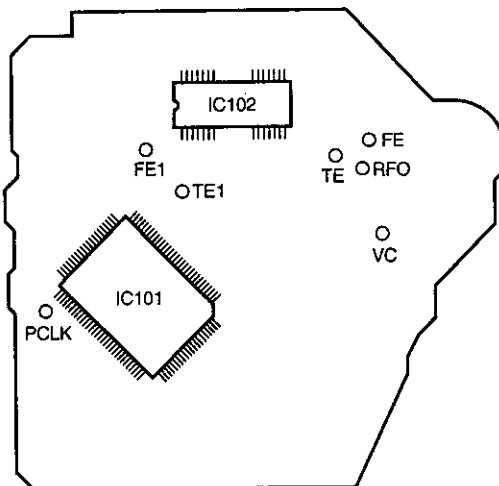

(3) Confirming Procedure

- 1) Actuate the service program.
- 2) Check the value of Focus gain automatic adjustment.
- 3) Check the value of Tracking gain automatic adjustment.
- 4) Check for Tracking offset.
- 5) Finish the service program and return the mode to normal operation (turn ON the power switch in normal manner).
- 6) Check for HF level.

(4) Confirming Focus Gain

- 1) Press **▶PLAY** button. (Track No. indication 03)
- 2) Press **⏸PAUSE** button. (Track No. indication 1-)
- 3) Check for automatic adjustment value.

Automatic adjustment value: 00 82 ~ 00 34 (normal temperature) (Test disc: CA-1094)
 01 04 ~ 00 28 (0°C~40°C)

Note: As it is a possibility of abnormality in pick-up when automatic adjustment value is 00 EE or less than 00 27 execute the confirmation for pick-up according to pick-up replacement standard.

If there is no abnormality in pick-up as described in pick-up replacement standard notes, no problem will occur for disc playback even though the automatic adjustment value is 00 EE or less than 00 27

(5) Confirming Tracking Gain

- 1) After checking the focus gain in (4) press **⏸PAUSE** button. (Track No. indication 2-).
- 2) Check for automatic adjustment value.

Automatic adjustment value: 00 81 ~ 00 23 (normal temperature) (Test disc: CA-1094)
 01 03 ~ 00 18 (0°C~40°C)

Note: As it is a possibility of abnormality in pick-up when automatic adjustment value is 00 EE or less than 00 22 execute the confirmation for pick-up according to pick-up replacement standard.

If there is no abnormality in pick-up as described in pick-up replacement standard notes, no problem will occur for disc playback even though the automatic adjustment value is 00 EE or less than 00 22

CD PLAYER SECTION

(6) Confirming Tracking offset (E/F Balance)

Connection			
Oscilloscope		Check	Step
V	H	(Oscilloscope)	<ol style="list-style-type: none"> 1. Push ▲ OPEN/CLOSE button and load disc holder reference disk. 2. Push ▲ OPEN/CLOSE button and close disc holder. 3. Push ▶ PLAY button to turn disc. (Displays track number 03) 4. Short (+)(-) of oscilloscope and check the base line. 5. Confirm that upper and lower amplitude of the waveform is symmetric against 0V.
0.1 v/div	1~2 ms/div		

(7) Confirming HF Level

Connection			
Oscilloscope		Check	Step
V	H	(Oscilloscope)	<ol style="list-style-type: none"> 1. Push the ▶ PLAY button while track number 03 is displayed. (Displays track number 04) 2. Check HF level of oscilloscope. 3. Confirm that the waveform is in good shape. (eye pattern in center must be able to discriminate clearly.)
50 mv/div or 20 mv/div	0.2 μs/div or 0.5 μs/div	<p>$A = 1.36 \pm 0.2 \text{ Vp-p}$</p>	
<ul style="list-style-type: none"> • Set input mode to ALTERNATE or CHOPPER. 			

CD PLAYER SECTION

μPD75517GF-369-3B9 (IC103)

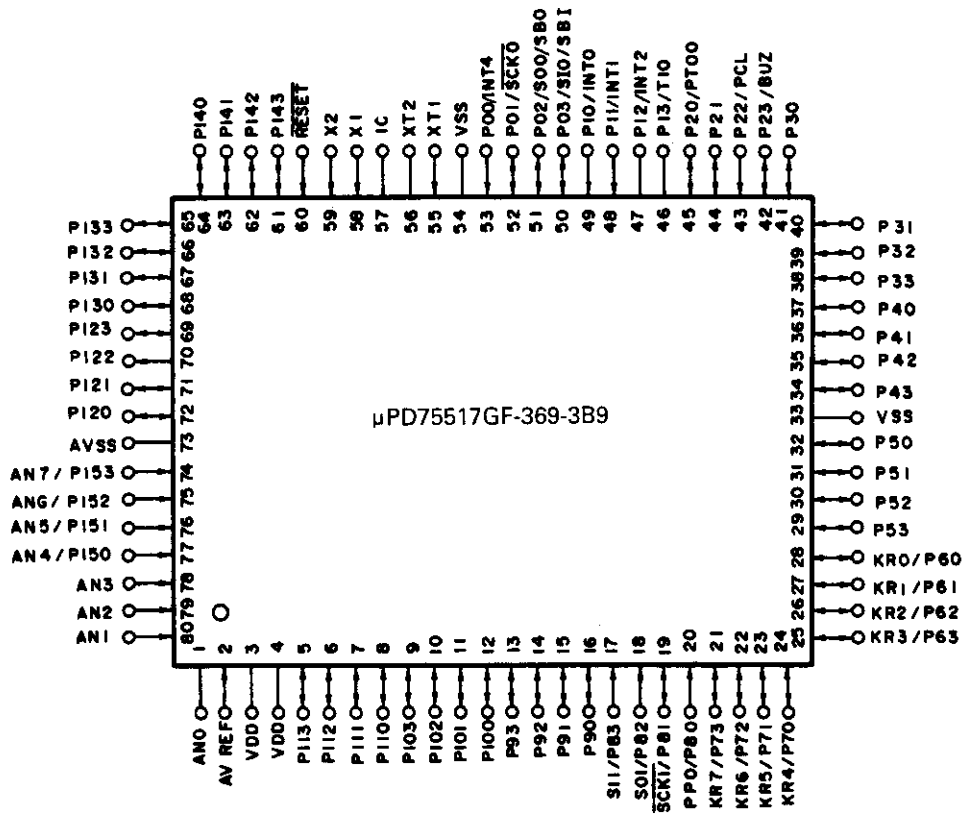
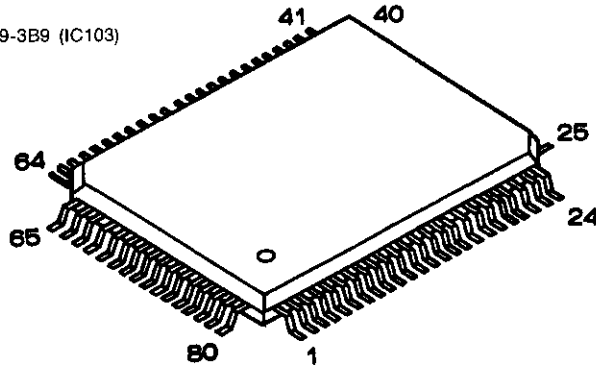

CD PLAYER SECTION

● Pin Description

Pin No.	Name	Port	I/O	Function	Operation Mode	Pin No.	Name	Port	I/O	Function	Operation Mode
1		AN0		Not used		41	SCLK	P30	OUT	Clock for SENS serial data read out	
2		AVREF		Not used		42	DATA	P23	OUT	LSI control	
3		VDD		+5 V power supply		43	XLT	P22	OUT	LSI control	
4		VDD		+5 V power supply		44	CLK	P21	OUT	LSI control	
5		P113		Not used		45	LASER	P20	OUT	Laser diode on/off	H = ON
6		P112		Not used		46	SENS	P13	IN	Use for SENS surveillance	
7		P111		Not used		47	GFS	INT2	IN	Used for GFS surveillance	
8		P110		Not used		48	SCOR	INT1	IN	Used for SCOR surveillance	
9	XRST	P103	OUT	LPeripheral IC reset	L→H	49	RXD	INT0	IN	RXD surveillance and reception	H→L→H
10		P102		Not used		50	SUB Q	SI0	IN	Used for sub code reception	H→L→H
11		P101		Not used		51		S00		Not used	
12		P100		Not used		52	SOCK	SCK0	OUT	Clock used for sub code reception	
13		P93		Not used		53	DSPENB	INT4	IN	Display transmission approval surveillance, L = Approval	
14		P92		Not used		54	GND	VSS			
15	PTSEARCH	P91		Outputs "H" during high-speed search	L→H→L	55		XT1		Not used; connected to GND	
16		P90		Not used		56		XT2		Not used	
17	DISPTRIG	SI1	IN	Display communications start trigger	H→L	57		IC		Not used; connected to GND	
18	DISPDATA	S01	OUT	Data line for LCD		58		X1		Ceramic oscillator, 4.00 MHz	
19	DISPCLK	SCK1	OUT	Communications clock for the display		59		X2		Ceramic oscillator	
20		PP0/P80		Not used		60		RESET	IN	Connected to RESET IC	L→H
21		KR7		Not used		61	FOK	P143	IN	Used for FOK surveillance	
22	KS2	KR6	OUT	Key scan (Edit Line)	L→H→L	62	SWOP	P142	IN	Used for Open Switch surveillance	L = Open
23	KS3	KR5	OUT	Key scan (FF Line)	L→H→L	63	SWCL	P141	IN	Used for Close Switch surveillance	L = Close
24	KS0	KR4	OUT	Key scan (OP/CL Line)	L→H→L	64		P140		Not used	
25		KR3/P63		Not used		65	CLS	P133	OUT	Tray Close	H = Close
26		KR2/P62		Not used		66	OPN	P132	OUT	Tray Open	H = Open
27		KR1/P61		Not used		67	DMUTE	P131	OUT	Digital mute on/off	L→H→L
28		KR0/P60		Not used		68	TXD	P130	OUT	Auto function transmission	
29		P53		Not used		69		P123		Not used	
30		P52		Not used		70	AMUTE	P122	OUT	Analog mute on/off, H = Off	H
31		P51		Not used		71	EMPH	P121	OUT	Emphasis on/off, H = On	
32		P50		Not used		72		P120		Not used	
33	GND	VSS		0 volts		73	GND	AVSS			
34		P43	IN	Not used		74	KR4	P153	IN	Key input	
35	SEL	P42	IN	Auto power off select	H = Auto mode	75	KR3	P152	IN	Key input	
36	CD-G	P41	IN	CD-G connection check, H = Connection		76	KR2	P151	IN	Key input	
37		P40	IN	Not used		77	KR1	P160	IN	Key input	
38		P33		Not used		78		AN3		Not used	
39		P32		Not used		79		AN2		Not used	
40		P31		Not used		80		AN1		Not used	

CD PLAYER SECTION

SEMICONDUCTORS

● IC's

BA6297AFP

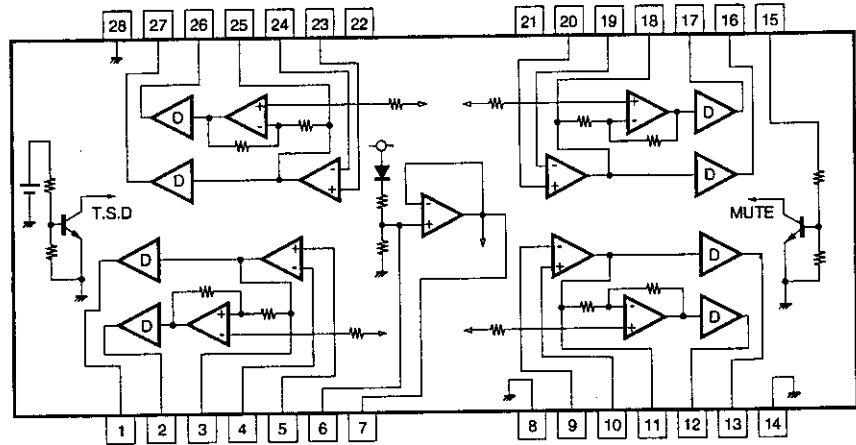
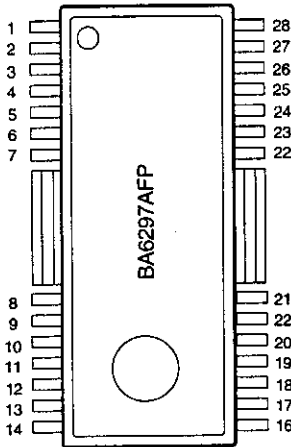
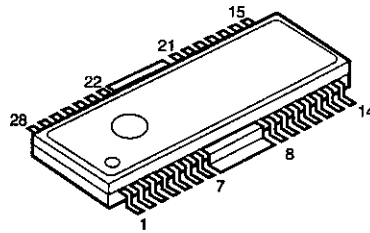

T.S.D: thermal short down
D: driver buffer

BA6297AFP Terminal Function

Pin No.	Symbol	I/O	Function
1		O	CH1 output terminal (+).
2		O	CH1 output terminal (-).
3		O	CH1 Pre-Amplifier output terminal.
4	I	I	CH1 Pre-Amplifier negative input terminal.
5		I	CH1 Pre-Amplifier positive input terminal.
6			Internal Vref-Amplifier resistor bias terminal.
7		O	Internal Vref-Amplifier output terminal.
8	GND		Vref-Amplifier and constant current ground.
9		I	CH2 Pre-Amplifier positive input terminal.
10		I	CH2 Pre-Amplifier negative input terminal.
11		O	CH2 Pre-Amplifier output terminal.
12		O	CH2 output terminal (-).
13		O	CH2 output terminal (+).
14	GND		CH2 and CH3 drive ground.

Pin No.	Symbol	I/O	Function
15		I	Driver mute control terminal.
16		O	CH3 output terminal (+).
17		O	CH3 output terminal (-).
18		O	CH3 Pre-Amplifier output terminal.
19		I	CH3 Pre-Amplifier negative input terminal.
20		I	CH3 Pre-Amplifier positive input terminal.
21	Vcc		CH2 and CH3 driver power supply.
22	Vcc		CH1 and CH4 driver power supply.
23		I	CH4 Pre-Amplifier positive input terminal.
24		I	CH4 Pre-Amplifier negative input terminal.
25		O	CH4 Pre-Amplifier output terminal.
26		O	CH4 output terminal (-).
27		O	CH4 output terminal (+).
28	GND		CH1 and CH4 driver ground.

Note: Each driver output polarity is reference to Pre-Amplifier output terminal polarity (+).

CD PLAYER SECTION

CXD2515Q

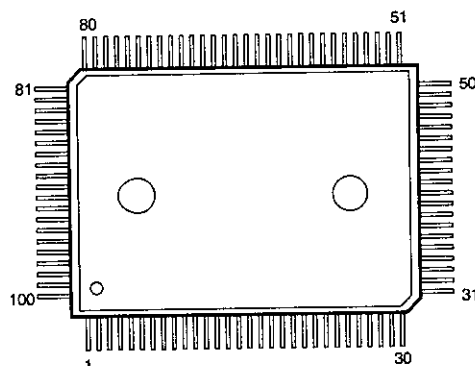
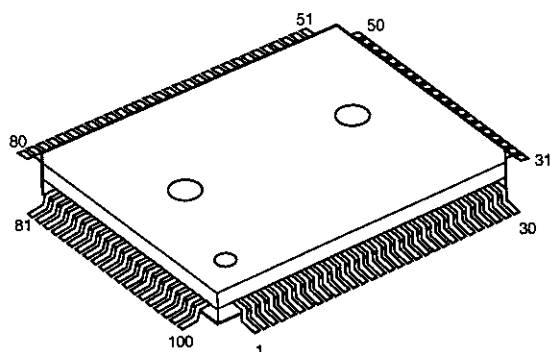

CXD2515Q Terminal Function

Pin No.	Symbol	I/O	Function
1	SRON	O	Sled drive output signal.
2	SRDR	O	Sled drive output signal.
3	SFON	O	Sled drive output signal.
4	TFDR	O	Tracking drive output signal.
5	TRON	O	Tracking drive output signal.
6	TRDR	O	Tracking drive output signal.
7	TFON	O	Tracking drive output signal.
8	FFDR	O	Focus drive output signal.
9	FRON	O	Focus drive output signal.
10	FRDR	O	Focus drive output signal.
11	FFON	O	Focus drive output signal.
12	VCOO	O	Osc. circuit output for analog EFM PLL.
13	VCOI	I	Osc. circuit output for analog EFM PLL.
14	TEST	I	Test terminal, normal GND.
15	DVss	-	Digital ground.
16	TES2	I	Test terminal, normally GND.
17	TES3	I	Test terminal, normally GND.
18	PDO	O	Change pump output for analog EFM PLL.
19	VPCO	O	PLL charge pump output for variable pitch.
20	VCKI	I	Clock input from external VCO for variable pitch.
21	AVD2	-	Analog power supply.
22	IGEN	I	Power supply terminal for OP amplifier.
23	AVS2	-	Analog ground.
24	ADII	I	A/D converter input terminal.
25	ADIO	O	OP amplifier output terminal.
26	RFDC	I	RF signal input.
27	TE	I	Tracking error signal input.
28	SE	I	Sled error signal input.
29	FE	I	Focus error signal input.
30	VC	I	Middle point voltage input terminal.
31	FILO	O	Filter output for master PLL.
32	FILI	I	Filter input for master PLL.
33	PCO	O	Charge pump output for master PLL.
34	CLTV	I	VCO control voltage input for master.
35	AVSI	-	Analog ground.
36	RFAC	I	EFM signal input.
37	BIAS	I	Asymmetry circuit constant current output.
38	ASY1	I	Asymmetry comparator voltage input.
39	ASY0	O	EFM full swing output.
40	AVDI	-	Analog power supply.

CD PLAYER SECTION

Pin No.	Symbol	I/O	Function
41	DV _{DD}	-	Digital power supply.
42	ASYE	I	Asymmetry circuit ON/OFF.
43	PSSL	I	Mode shift input of audio data output.
44	WDCK	O	48 bit slot D/A interface word clock.
45	LRCK	O	48 bit slot D/A interface LR clock.
46	DATA	O	DA16 output at PSSL=1, 48 bit slot serial data at PSSL=0.
47	BCLK	O	DA15 output at PSSL=1, 48 bit slot bit clock at PSSL=0.
48	64DATA	O	DA14 output at PSSL=1, 64 bit slot serial data at PSSL=0.
49	64BCLK	O	DA13 output at PSSL=1, 64 bit slot bit clock at PSSL=0.
50	64LRCK	O	DA12 output at PSSL=1, 64 bit slot LR clock at PSSL=0.
51	GTOP	O	DA11 output at PSSL=1, GTOP output at PSSL=0.
52	XUGF	O	DA10 output at PSSL=1, XUGF output at PSSL=0.
53	XPLCK	O	DA09 output at PSSL=1, XPLCK output at PSSL=0.
54	GFS	O	DA08 output at PSSL=1, GFS output at PSSL=0.
55	RFCK	O	DA07 output at PSSL=1, RFCK output at PSSL=0.
56	C2PO	O	DA06 output at PSSL=1, C2PO output at PSSL=0.
57	XRAOF	O	DA05 output at PSSL=1, XRAOF output at PSSL=0.
58	MNT3	O	DA04 output at PSSL=1, MNT3 output at PSSL=0.
59	MNT2	O	DA03 output at PSSL=1, MNT2 output at PSSL=0.
60	MNT1	O	DA02 output at PSSL=1, MNT1 output at PSSL=0.
61	MNT0	O	DA01 output at PSSL=1, MNT0 output at PSSL=0.
62	XTAI	I	X'tal Osc. circuit input.
63	XTAO	O	X'tal Osc. circuit output.
64	XTSL	I	X'tal select input terminal.
65	DV _{SS}	-	Digital ground.
66	FSTI	I	2/3 cycle input of Pin 62, 63
67	FSTO	O	2/3 cycle output of Pin 62, 63
68	C4M	O	4.2336 MHz output.
69	C16M	O	16.9344 MHz output.
70	MD2	I	Digital-Out ON/OFF control terminal.
71	DOUT	O	Digital-Out output terminal.
72	EMPH	O	Playback disc emphasis mode output.
73	WFCK	O	WFCK output.
74	SCOR	O	Sub code sync output terminal.
75	SBSO	O	Sub P~W serial output.
76	EXCK	I	Clock input for SBSO read out.
77	SUBQ	O	Sub Q 80 bit output.
78	SQCK	I	Clock input for SQSO read out.
79	MUTE	I	Mute shift terminal.
80	SENS	O	SENS output.
81	XRST	I	System reset.
82	DIRC	I	Using at 1 track jump.
83	SCLK	I	Clock for SENS serial data read out.
84	DFSW	I	DFCT shift terminal.
85	ATSK	I	Anti-shock terminal.
86	DATA	I	Serial data input from CPU.
87	XLAT	I	Latch input from CPU.
88	CLOK	I	Serial data transfer clock input from CPU.

LC78835M

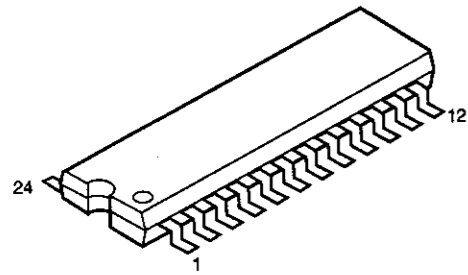

PST600F

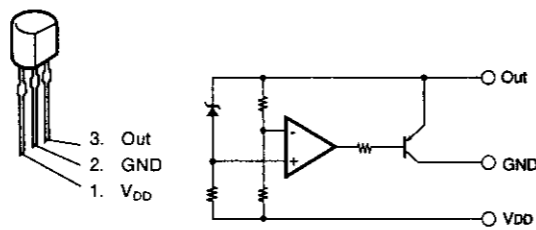

● Transistors

2SD1762 (E/F)

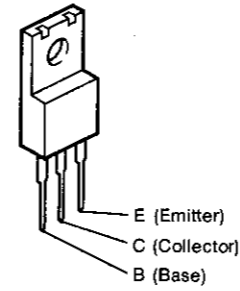

- DTA124ES PNP type
- DTC144ES } NPN type
- DTC323TS
- DTC114ES

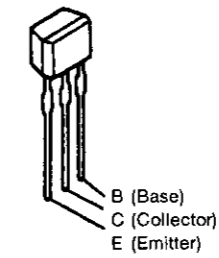

2SA933S(S)

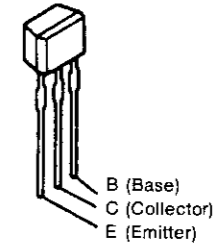

PNP type

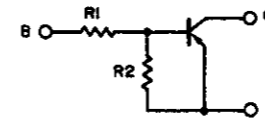

NPN type

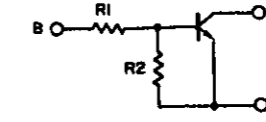

	R1	R2
DTA124ES	22k ohm	22k ohm

	R1	R2
DTC144ES	47k ohm	47k ohm
DTC323TS	2.2k ohm	-
DTC114ES	10k ohm	10k ohm

● Diodes

1S252

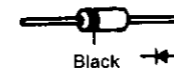

1SR35-200A

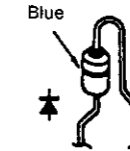

MTZJ4.7A
MTZJ8.2A

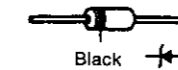

● IC PROTECTORS

ICP-N15 (IC253)

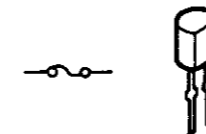

LC78835M

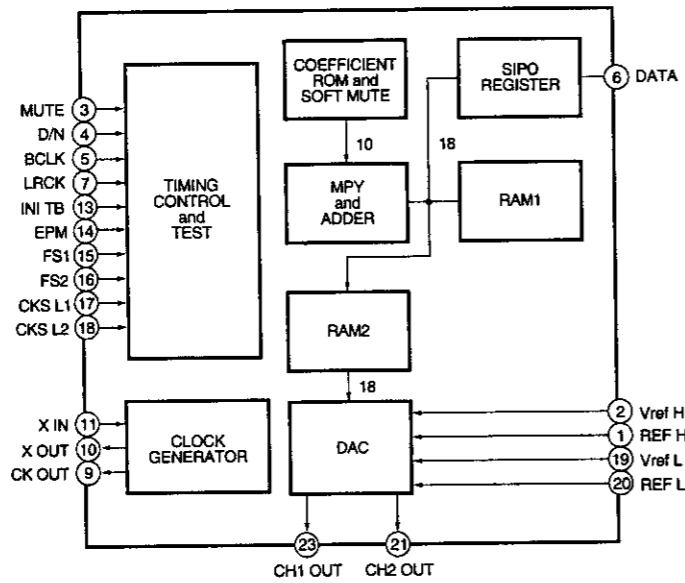
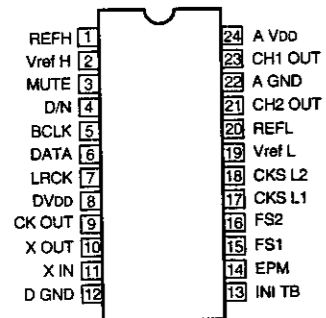

BA178M05 (IC251)

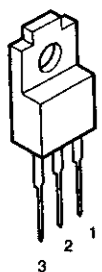

1: Output
2: GND
3: Input

BA6287F

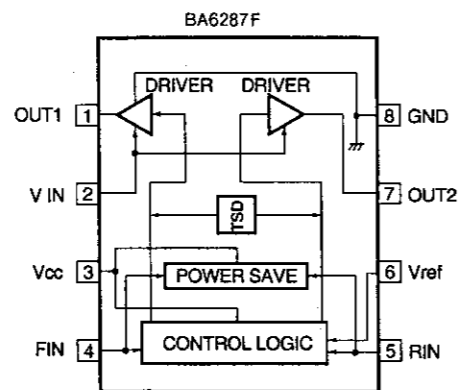
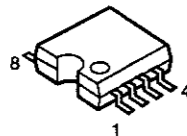

CD PLAYER SECTION

PRINTED WIRING BOARD

1 2 3 4 5 6 7 8

KU-9282 CD UNIT ASS'Y
Component Side

KU-9334 CD UNIT ASS'Y	
1	MAIN UNIT
2	DISPLAY UNIT

A

B

C

D

E

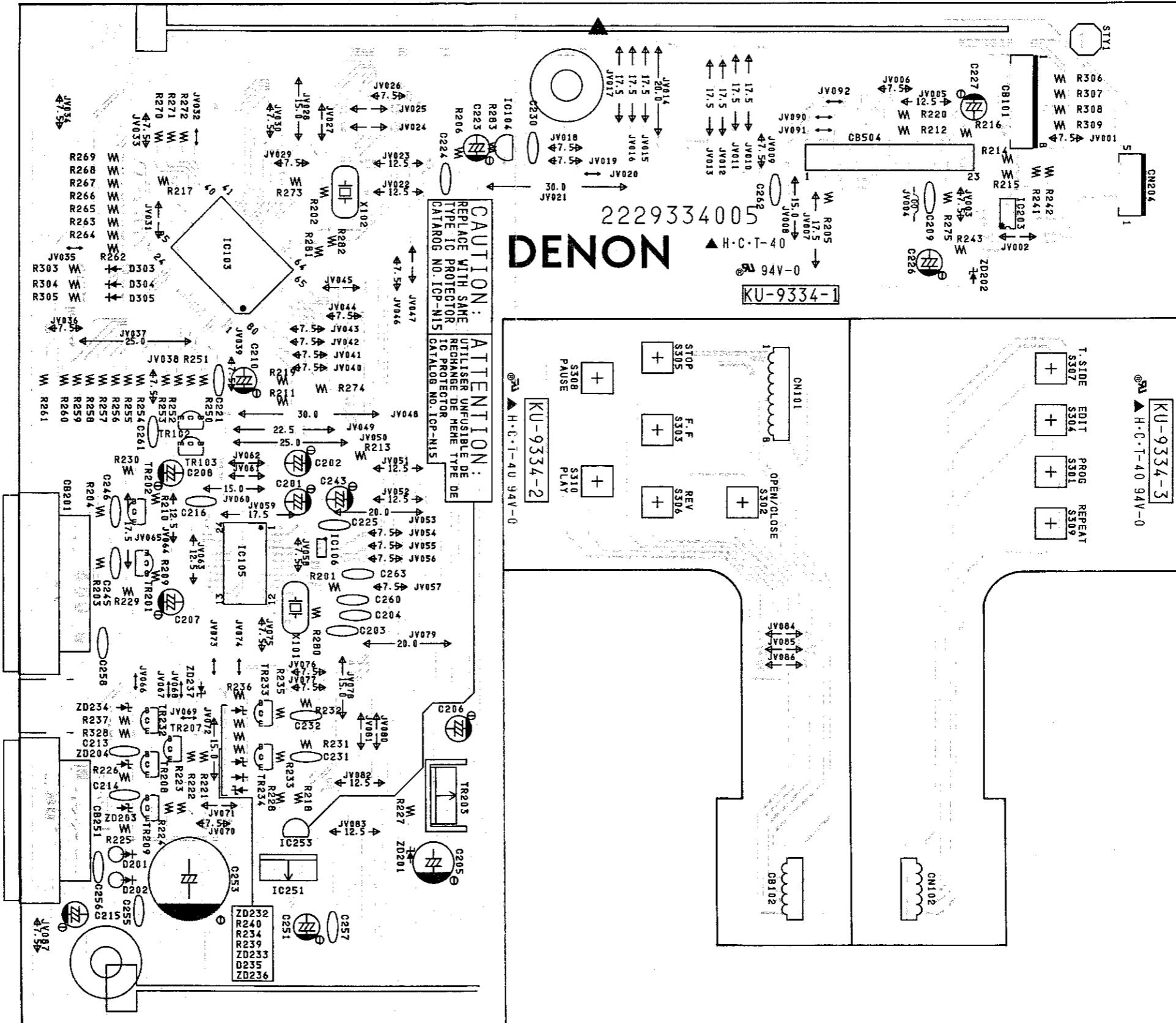

DENON

2229334005

KU-9334-1

KU-9334-2

KU-9334-3

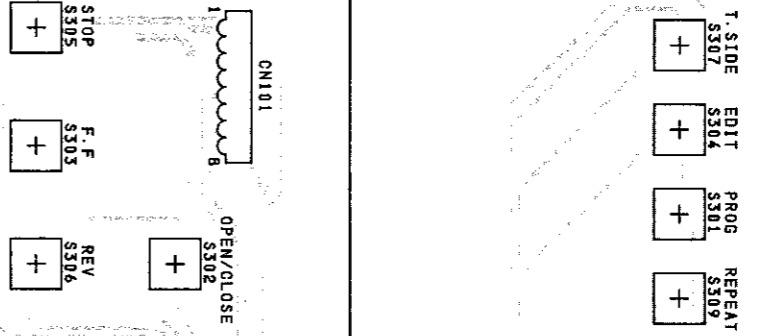

H.C.T-40 94V-0

CD PLAYER SECTION

NOTE ON PARTS LIST

- Part indicated with the mark "●" are not always in stock and possibly to take a long period of time for supplying, or in some case supplying of part may be refused.
- When ordering of part, clearly indicate "1" and "I" (i) to avoid mis-supplying.
- Ordering part without stating its part number can not be supplied.
- Part indicated with the mark "★" is not illustrated in the exploded view.
- Not including Carbon Film ±5%, 1/4W Type in the P.W. Board parts list. (Refer to the Schematic Diagram for those parts.)

WARNING:

Parts marked with this symbol Δ \square have critical characteristics.
Use ONLY replacement parts recommended by the manufacturer.

● **Resistors**

Ex.: **RN 14K 2E 182 G FR**
Type Shape Power Resist- Allowable Others
 and per- ance error
 formance

RD : Carbon Film	2B : 1/8W	F : ±1%	P : Pulse-resistant type
RC : Composition	2E : 1/4W	G : ±2%	NL : Low noise type
RS : Metallic oxide Film	2H : 1/2W	J : ±5%	NB : Non-burning type
RW : Winding	3A : 1W	K : ±10%	FR : Fuse-resistor
RN : Metal film	3D : 2W	M : ±20%	F : Lead wire forming
RK : Metal mixture	3F : 3W		
	3H : 5W		

* **Resistance**

1 B 2 ⇒ 1800 ohm = 1.8 kohm
↑ ↑ ↑
Indicates number of zeros after effective number
2-digit effective number

• Units: ohm

1 R 2 ⇒ 1.2 ohm
↑ ↑ ↑
1-digit effective number.
2-digit effective number, decimal point indicated by R.

• Units: ohm

* **Capacity (electrolyte only)**

2 2 R ⇒ 2200 μF
↑ ↑ ↑
Indicates number of zeros after effective number.
2-digit effective number.

• Units: μF

2 R 2 ⇒ 2.2 μF
↑ ↑ ↑
1-digit effective number.
2-digit effective number, decimal point indicated by R.

• Units: μF

● **Capacitors**

Ex.: **CE 04W 1H 2R2 M BP**
Type Shape Dielectric Capacity Allowable Others
 and per- strength error
 formance

CE : Aluminum foil electrolyte	0J : 6.3V	F : ±1%	HS : High stability type
CA : Aluminum solid electrolyte	1A : 10V	G : ±2%	BP : Non-polar type
CS : Tantalum electrolyte	1C : 16V	J : ±5%	HR : Ripple-resistant type
CQ : Film	1E : 25V	K : ±10%	DL : For charge and discharge
CK : Ceramic	1V : 35V	M : ±20%	HF : For assuring high frequency
CC : Ceramic	1H : 50V	Z : +80%	U : UL part
CP : Oil	2A : 100V	-20%	C : CSA part
CM : Mica	2B : 125V	P : +100%	W : UL-CSA type
CF : Metallized	2C : 160V	-0%	F : Lead wire forming
CH : Metallized	2D : 200V	C : ±0.25pF	
	2E : 250V	D : ±0.5pF	
	2H : 500V	= : Others	
	2J : 630V		

* **Capacity (except electrolyte)**

2 R 2 ⇒ 2200pF = 2200 μF = 0.002 μF
↑ ↑ ↑
(More than 2) — Indicates number of zeros after effective number.
2-digit effective number.

• Units: μF

2 2 1 ⇒ 220pF
↑ ↑ ↑
(0 or 1) — Indicates number of zeros after effective number.
2-digit effective number.

• Units: pF

• When the dielectric strength is indicated in AC, "AC" is included after the dielectric strength value.

KU-9334 PARTS LIST OF UCD-77

Ref. No.	Part No.	Part Name	Remarks	Ref. No.	Part No.	Part Name	Remarks	Qty
SEMICONDUCTORS GROUP				CN101	204 2612 030	8 P KR-DA Conn. Cord WT		1
IC103	262 2233 004	IC UPD75517GF--369		CB101	205 0343 087	8 P Conn. Base(KR-PH)		1
IC104	263 1026 901	IC PST600F		CB201	204 8284 022	15 P System Socket		1
IC105	262 1824 906	IC LC78835M		CB204	205 0829 051	5 P CT Conn. Base		1
IC106	262 2257 909	IC TC4S81F TE85L		CB251	205 0730 056	13 P System Socket(BU)		1
IC203	263 0994 908	IC BA6287F		CB504	205 0990 003	23 P FFC Conn. Base		1
IC251	263 1024 000	IC BA178M05			205 0452 017	Style Pin		1
IC253	268 0073 905	IC ICP-N15			412 9483 009	Earth Plate		1
TR102	269 0020 906	Transistor DTC114ES	Built in Resistor					
TR103	269 0063 905	Transistor DTA124ES	Built in Resistor					
TR201,202	269 0072 909	Transistor DTC323TS						
TR203	274 0120 002	Transistor 2SD1762(E/F)						
TR207~209	269 0040 902	Transistor DTC144ES	Built in Resistor					
TR232	269 0020 906	Transistor DTC114ES	Built in Resistor					
TR233,234	271 0192 905	Transistor 2SA933S(S)						
D201,202	276 0553 905	Diode 1SR35-200A(T93X)						
D235	276 0616 907	Diode 1SS252						
D303~305	276 0616 907	Diode 1SS252						
ZD201	276 0644 924	Zener Diode MTZJ8.2A						
ZD202	276 0643 970	Zener Diode MTZJ4.7A						
ZD203,204	276 0644 924	Zener Diode MTZJ8.2A						
ZD232~234	276 0644 924	Zener Diode MTZJ8.2A						
ZD236,237	276 0644 924	Zener Diode MTZJ8.2A						
CAPACITORS GROUP				C201,202	254 4254 909	Electrolytic 10 μ F/16V	CE04W1C100M(SME)	
C203,204	253 4536 983	Chip Ceramic 22 pF/50V	CC45SL1H220J(DD-3)					
C205	254 4254 954	Electrolytic 220 μ F/16V	CE04W1C221M(SME)					
C206~208	254 4254 909	Electrolytic 10 μ F/16V	CE04W1C100M(SME)					
C209	253 1181 904	Chip Ceramic 0.01 μ F/50V	CK45F1H103Z(DD-3)					
C210	254 4252 930	Electrolytic 100 μ F/10V	CE04W1A101M(SME)					
C213,214	253 1179 987	Chip Ceramic 470 pF/50V	CK45B1H471K(DD-3)					
C215	254 4260 948	Electrolytic 1 μ F/50V	CE04W1H010M(SME)					
C216	253 1181 904	Chip Ceramic 0.01 μ F/50V	CK45F1H103Z(DD-3)					
C221	253 1181 904	Chip Ceramic 0.01 μ F/50V	CK45F1H103Z(DD-3)					
C223	254 4260 919	Electrolytic 0.22 μ F/50V	CE04W1HR22M(SME)					
C224,225	253 1181 904	Chip Ceramic 0.01 μ F/50V	CK45F1H103Z(DD-3)					
C226,227	254 4254 909	Electrolytic 10 μ F/16V	CE04W1C100M(SME)					
C230	253 1181 904	Chip Ceramic 0.01 μ F/50V	CK45F1H103Z(DD-3)					
C231,232	253 4538 949	Chip Ceramic 100 pF/50V	CC45SL1H101J(DD-3)					
C243	254 4250 932	Electrolytic 220 μ F/5.6V	CE04W0J221M(SME)					
C245,246	253 4538 949	Chip Ceramic 100 pF/50V	CC45SL1H101J(DD-3)					
C251	254 4252 930	Electrolytic 100 μ F/10V	CE04W1A101M(SME)					
C253	254 4255 717	Electrolytic 4700 μ F/16V	CE04W1C472M(SME)					
C255~258	253 1181 904	Chip Ceramic 0.01 μ F/50V	CK45F1H103Z(DD-3)					
C260~262	253 1181 904	Chip Ceramic 0.01 μ F/50V	CK45F1H103Z(DD-3)					
C263	253 1180 921	Chip Ceramic 1000 pF/50V	CK45B1H102K(DD-3)					
OTHER GROUP								
		(P.W.Board)						(1)
X101	399 0200 904	Ceramic Resonator	CSA4.00MGW-TF01					1
X102	399 0191 903	Ceramic Resonator	CST16.93MX					1
SW301~310	212 5604 907	Tact Switch						11

CD PLAYER SECTION

PARTS LIST OF CD MECHANISM UNIT

SA4 6494 32A CD MECHANISM P.W.B. UNIT ASS'Y

S16 4572 111 LOADING P.W.B. UNIT ASS'Y

Ref. No.	Part No.	Part Name	Remarks	Ref. No.	Part No.	Part Name	Remarks
SEMICONDUCTORS GROUP				OTHER GROUP			
IC101	262 1879 003	IC CXD2515Q		S151	S15 7208 511	Leaf Switch (Limit)	
IC102	926 0000 100	IC BA297AFP		S152	S15 7208 511	Leaf Switch (Limit)	
RESISTORS GROUP (Not included Carbon Film $\pm 5\%$, 1/4W Type. Refer to the Schematic Diagram for those Parts.)				CN151	S15 6894 311	5 P Connector Base (L Type)	
R101	247 0010 929	Chip Carbon 15 kohm 1/10W	RM73B--153J				
R102	247 0012 927	Chip Carbon 100 kohm 1/10W	RM73B--104J				
R103	247 0010 929	Chip Carbon 15 kohm 1/10W	RM73B--153J				
R104	247 0011 902	Chip Carbon 33 kohm 1/10W	RM73B--333J				
R105	247 0012 927	Chip Carbon 100 kohm 1/10W	RM73B--104J				
R106,107	247 0008 960	Chip Carbon 3.3 kohm 1/10W	RM73B--332J				
R108	247 0009 985	Chip Carbon 10 kohm 1/10W	RM73B--103J				
R109	247 0014 967	Chip Carbon 1 Mohm 1/10W	RM73B--105J				
R110	247 0005 905	Chip Carbon 100 ohm 1/10W	RM73B--101J				
R112	247 0007 945	Chip Carbon 1 kohm 1/10W	RM73B--102J				
R113,114	247 0010 929	Chip Carbon 15 kohm 1/10W	RM73B--153J				
R117,118	247 0010 929	Chip Carbon 15 kohm 1/10W	RM73B--153J				
R121,122	247 0010 929	Chip Carbon 15 kohm 1/10W	RM73B--153J				
R123	247 0009 985	Chip Carbon 10 kohm 1/10W	RM73B--103J				
R124	247 0012 927	Chip Carbon 100 kohm 1/10W	RM73B--104J				
R125~127	247 0007 945	Chip Carbon 1 kohm 1/10W	RM73B--102J				
R131	247 0006 920	Chip Carbon 330 ohm 1/10W	RM73B--331J				
R151~156	247 0009 956	Chip Carbon 7.5 kohm 1/10W	RM73B--752J				
R157	247 0011 986	Chip Carbon 68 kohm 1/10W	RM73B--683J				
R158	247 0010 916	Chip Carbon 13 kohm 1/10W	RM73B--133J				
R159	247 0011 902	Chip Carbon 33 kohm 1/10W	RM73B--333J				
R160	247 0010 961	Chip Carbon 22 kohm 1/10W	RM73B--223J				
R161	247 0101 980	Chip Carbon 4.7 ohm 1/10W	RM73B--4R7J				
R162,163	247 0011 986	Chip Carbon 68 kohm 1/10W	RM73B--683J				
CAPACITORS GROUP							
C101	257 0008 941	Chip Ceramic 470 pF/50V	CK73B1H471K				
C102	257 0014 935	Chip Ceramic 0.1 μ F/25V	CK73F1E104Z				
C103	257 0008 941	Chip Ceramic 470 pF/50V	CK73B1H471K				
C105	S11 3515 521	Chip Ceramic 4.7 μ F/16V					
C106	S11 6434 611	Chip Ceramic 1 μ F/16V					
C107	S11 6450 511	Chip Ceramic 2.2 μ F/16V					
C108	257 0013 907	Chip Ceramic 0.047 μ F/50V	CK73F1H473Z				
C109	257 0009 908	Chip Ceramic 1500 pF/50V	CK73B1H152K				
C110	S11 6301 700	Chip Ceramic 4700 pF/50V					
C111	257 0004 961	Chip Ceramic 100 pF/50V	CC73SL1H101J				
C112,113	257 0014 935	Chip Ceramic 0.1 μ F/25V	CK73F1E104K				
C123	257 0012 966	Chip Ceramic 0.01 μ F/50V	CK73F1H103Z				
C124	S11 6400 511	Chip Ceramic 0.47 μ F/25V					
C151,152	257 0008 967	Chip Ceramic 680 pF/50V	CK73B1H681K				
C153	257 0014 935	Chip Ceramic 0.1 μ F/25V	CK73F1E104K				
C154	257 0014 906	Chip Ceramic 0.33 μ F/25V	CK73F1E334K				
C155,156	257 0008 967	Chip Ceramic 680 pF/50V	CK73B1H681K				
C157,158	257 0012 982	Chip Ceramic 0.022 μ F/50V	CK73F1H223Z				
C159	S11 6302 300	Chip Ceramic 0.015 μ F/50V	CK73B1H153K				
C160	257 0012 953	Chip Ceramic 6800 pF/50V	CK73F1H682Z				
C161	257 0014 935	Chip Ceramic 0.1 μ F/25V	CK73F1E104Z				
OTHER GROUP							
CN101	S15 6886 511	23 P Connector Base					
CN102	S15 6879 511	12 P Connector Base					
S101	S15 7208 511	Leaf Switch (Limit)					

CD PLAYER SECTION

WIRING DIAGRAM

1

2

3

4

A

B

C

D

E

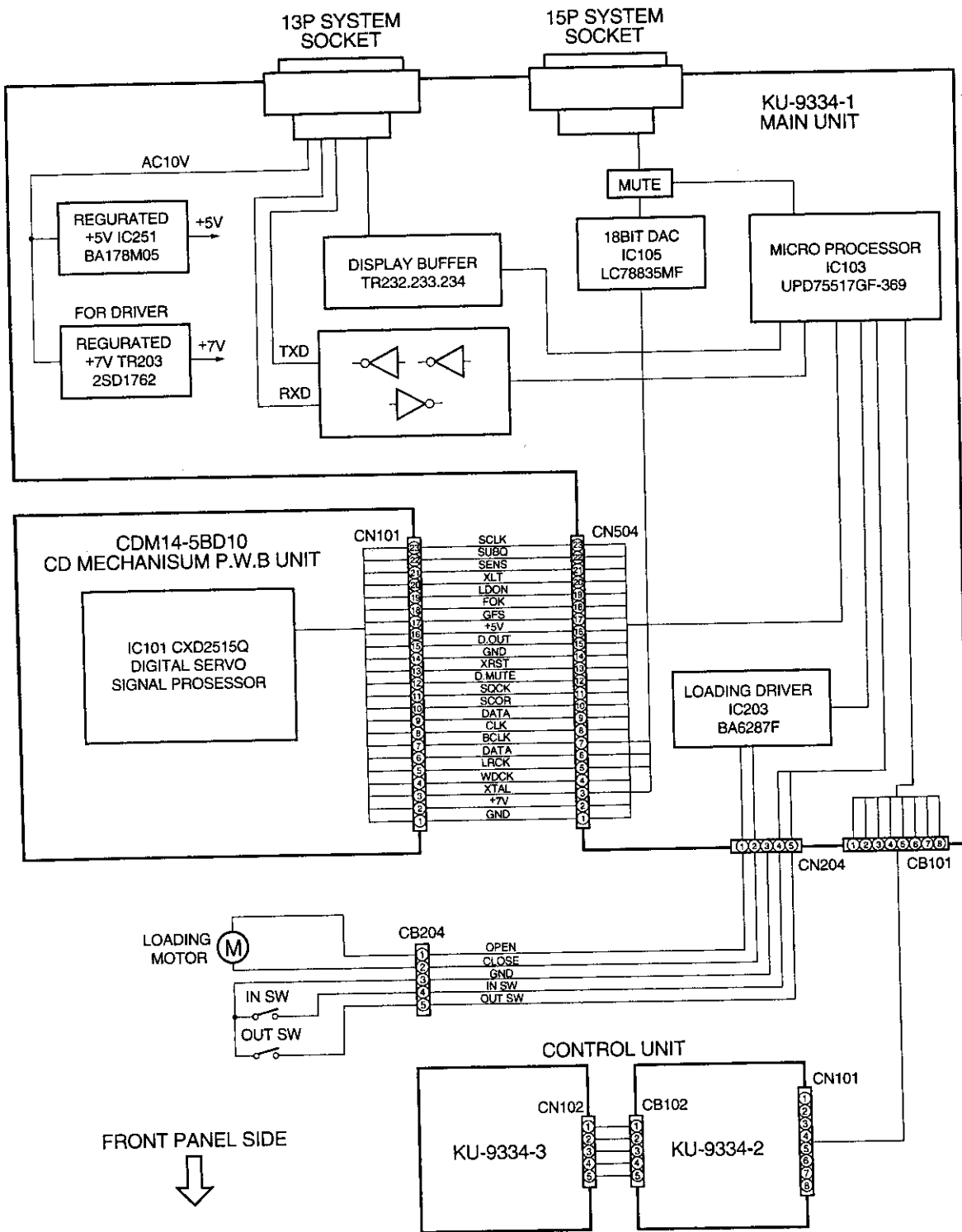

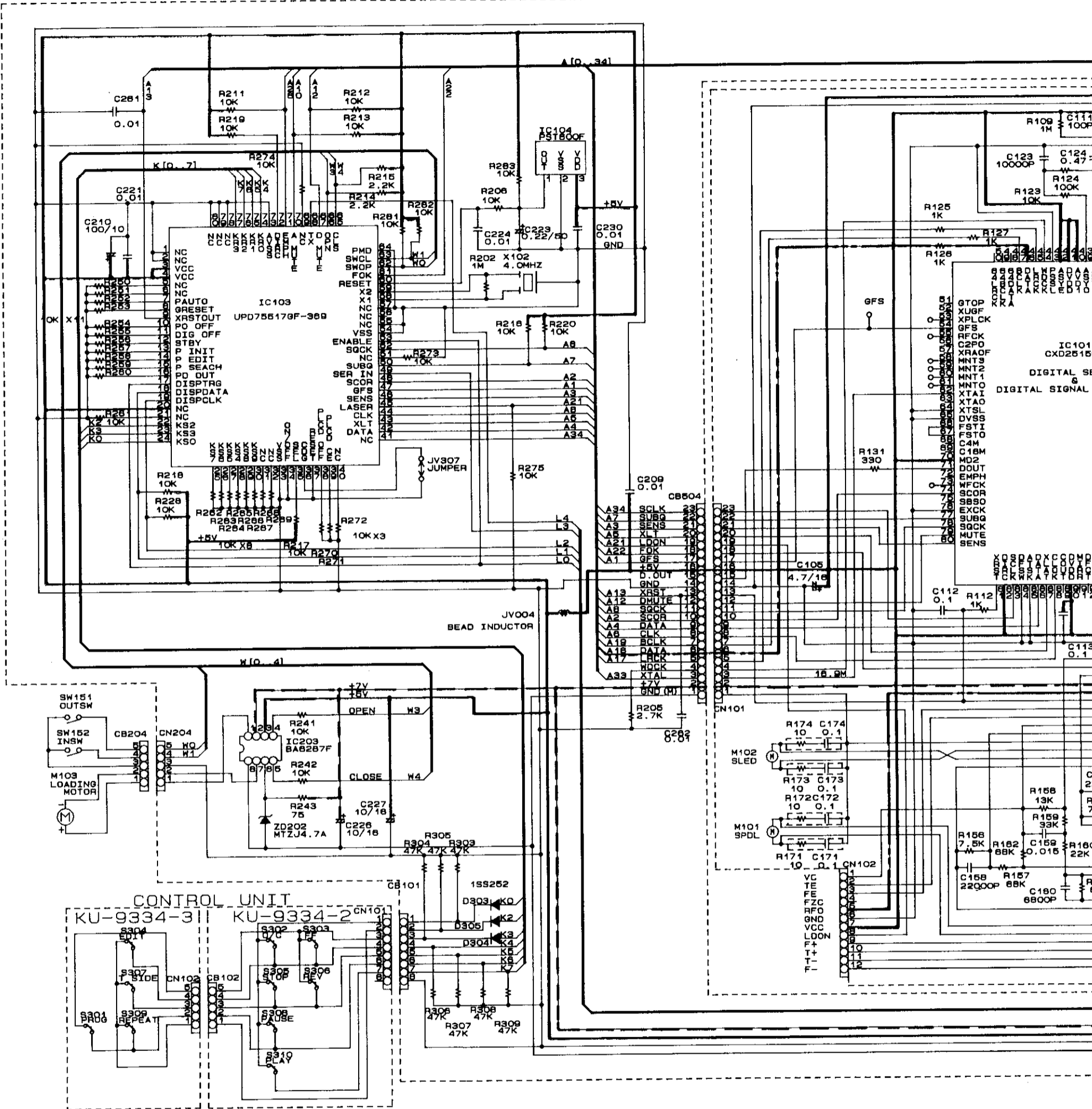

- - - - - +B LINE
 - - - - - +7V LINE
 - - - - - +5V LINE
 - - - - - 1-ch LINE
 - - - - - R-ch LINE
 - - - - - DIGITAL SIGNAL LINE

WARNING:
 Parts marked with this symbol Δ have critical characteristics.
 Use ONLY replacement parts recommended by the manufacturer.

CAUTION:
 Before return
 leakage curre
 defective.

WARNING
 DO NOT return

6 7 8 9 10 11

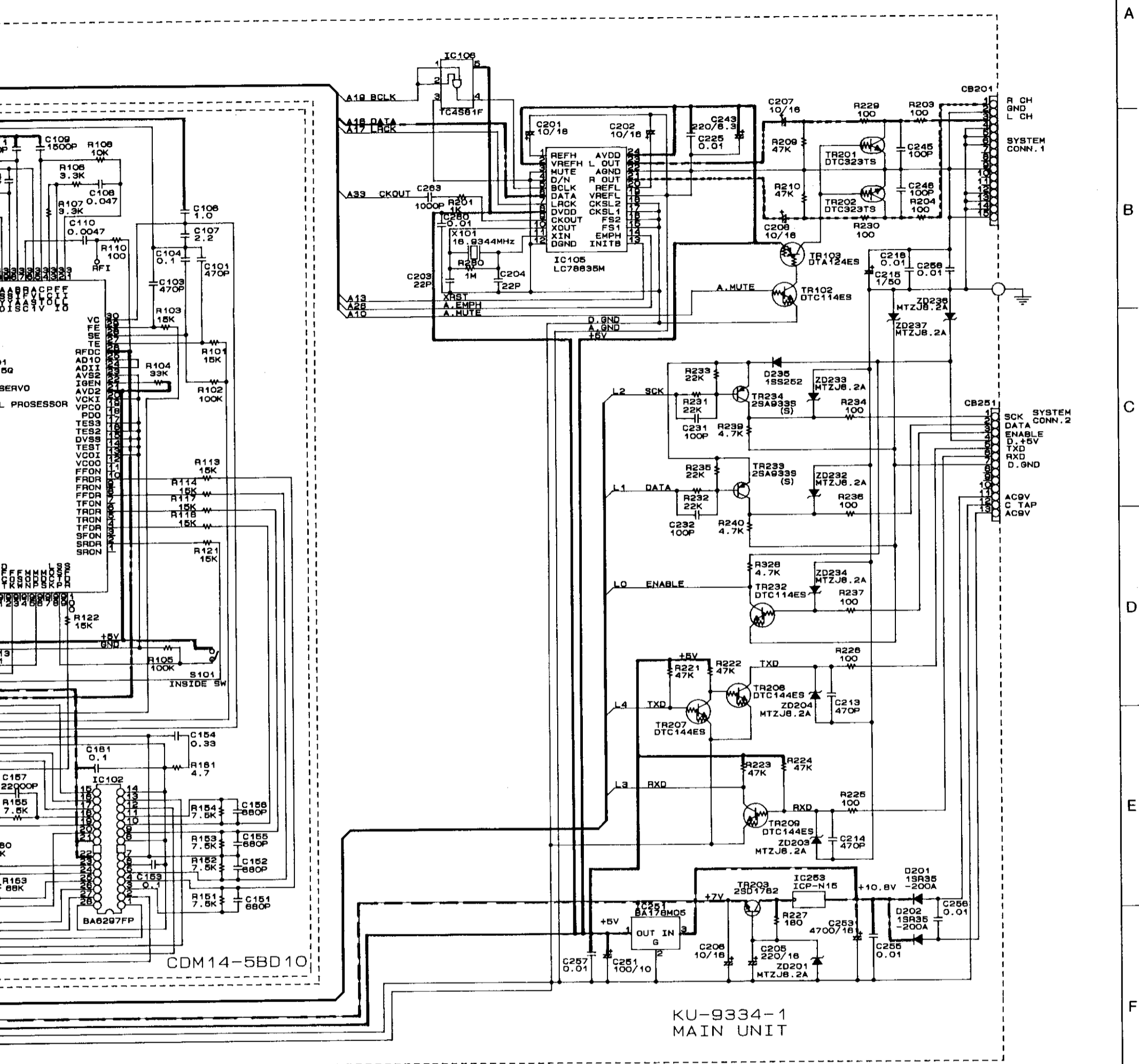

NOTES
 ALL RESISTANCE VALUES IN OHM K=1,000 OHM M=1,000,000 OHM
 ALL CAPACITANCE VALUES IN MICRO FARAD P=MICRO-MICRO FARAD
 EACH VOLTAGE AND CURRENT ARE MEASURED AT NO SIGNAL INPUT CONDITION.
 CIRCUIT AND PARTS ARE SUBJECT TO CHANGE WITHOUT PRIOR NOTICE.

When returning the unit to the customer, make sure you make either (1) a leakage current check or (2) a line to chassis resistance check. If the leakage current exceeds 0.5 milliamps, or if the resistance from chassis to either side of the power cord is less than 240 Kohms, the unit is not to be returned to the customer until the problem is located and corrected.

A
B
C
D
E
F
G
H

CD PLAYER SECTION

PARTS LIST OF UCD-77 EXPLODED VIEW

Ref. No.	Part No.	Part Name	Remarks	Qty
● 1	KU- 9334	Main Unit Ass'y		1 ^S
└ 1-1	—	Main Unit		(1)
└ 1-2	—	Control Unit		(1)
2	254 4255 717	Chemicon 4700 μ F/16V		(1)
● 3	411 9115 316	Main chassis		1
4	104 0237 308	Foot Ass'y		4
● 5	105 9235 126	Black Panel		1
6	513 2358 007	Laser Caution		1
7	449 9037 004	Mecha Holder(CD)		1
● 8	337 0040 001	CD Mecha Unit		1
● 9	412 2814 028	Card Spacer(L=10)		1
● 10	146 9348 315	inner Panel		1
11	113 9322 108	4 G Button		1
12	113 9330 006	6 G Button		1
● 13	144 9235 105	Front Panel		1
14	146 9349 107	Loader panel(CD)		1
15	146 9346 207	Side Plate(R)		1
16	146 9347 206	Side Plate(L)		1
● 17	102 9043 018	Top Cover		1
★ 18	513 9390 000	Rating Sheet		1
19	204 8284 022	15 P System Socket		1
20	205 0730 056	13 P System Socket(Bu)		1
★ 21	203 8385 009	5 P DA-DA Conn. Cord(Amp)		1
22	009 9058 005	23 P FF Cable		1
SCREWS				
51	473 7002 018	Tapping Screw(S) 3×8		11
52	473 7015 018	Tapping Screw(S) 3×8	Black	14
53	473 7015 005	Tapping Screw(S) 3×6	Black	3
54	473 7500 044	Tapping Screw(P) 3×8	Black	2
55	473 7505 007	Tapping Screw(P) 2.6×8		7
56	473 7009 008	FH.Tapping Screw(S) 3×6		2
PACKING & ACCESSORIES (Not included EXPLODED VIEW)				
71	505 0241 005	Cabinet Cover		1
72	503 9293 207	Cushion		1

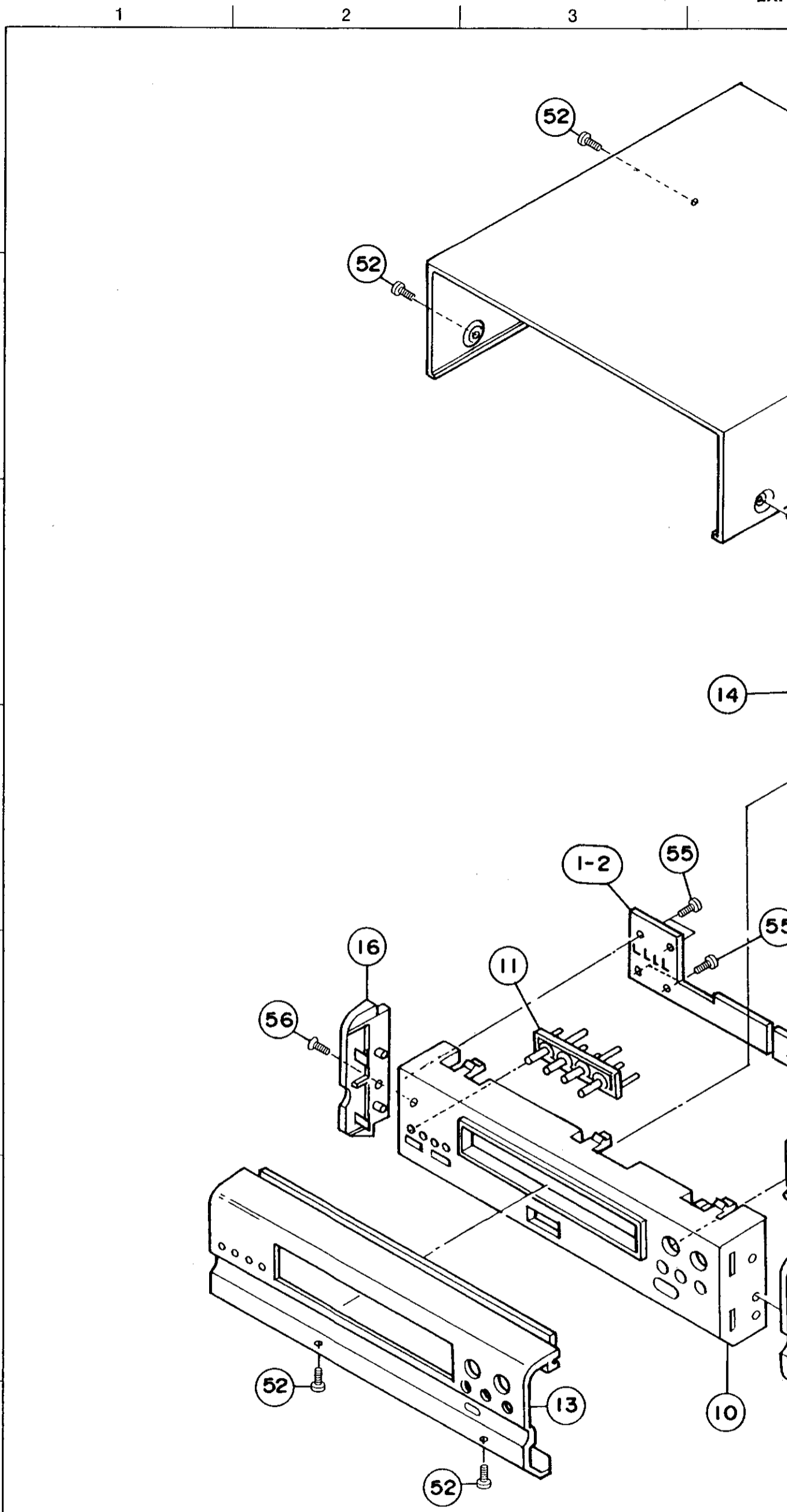

NOTE ON PARTS LIST

- Part indicated with the mark "●" are not always in stock and possibly to take a long period of time for supplying of part may be refused.
- When ordering of part, clearly indicate "1" and "1" (i) to avoid mis-supplying.
- Ordering part without stating its part number can not be supplied.
- Part indicated with the mark "★" is not illustrated in the exploded view.

WARNING:

Parts marked with this symbol have critical characteristics. Use ONLY replacement parts recommended by the manufacturer.

EXPLODED VIEW

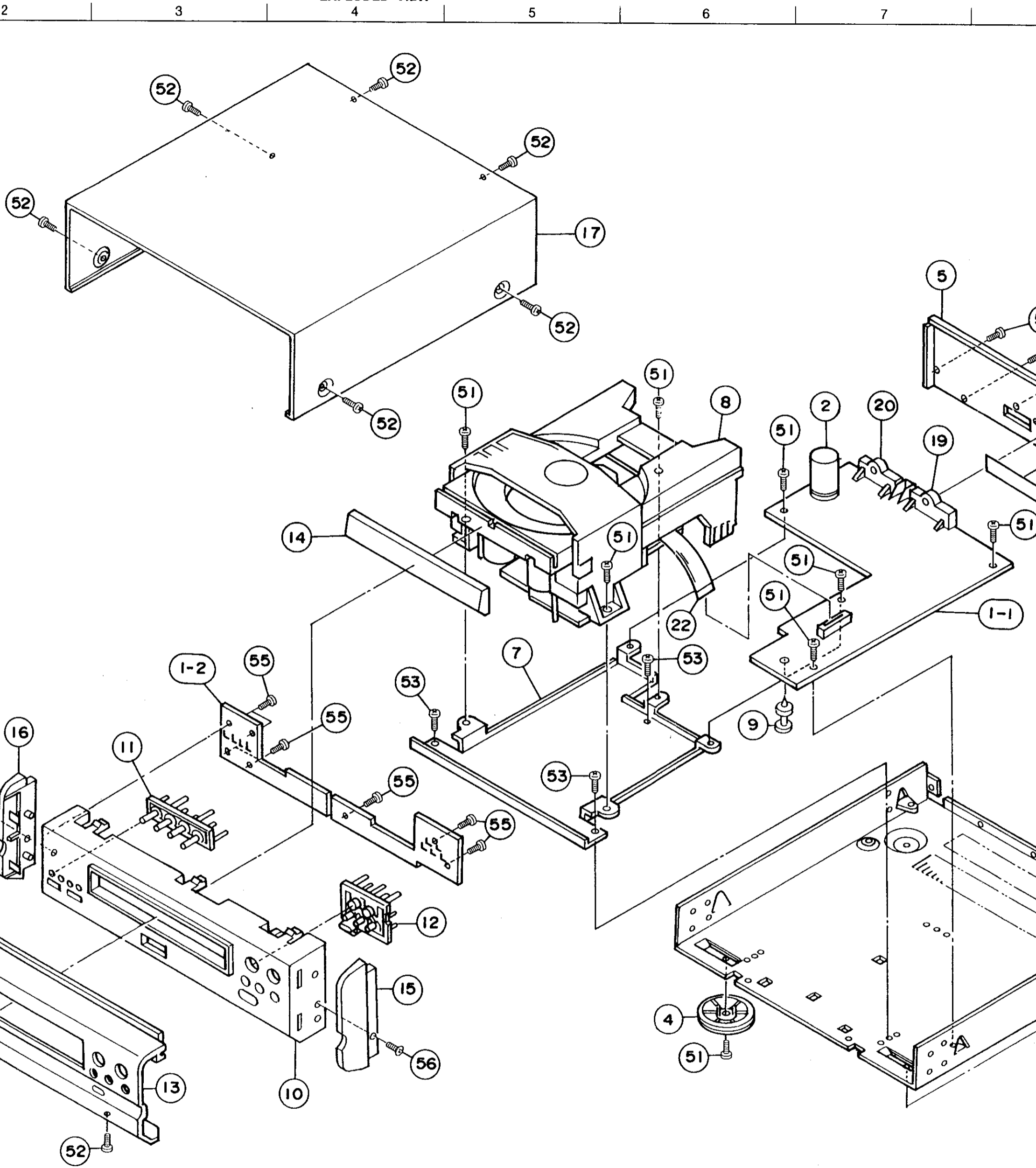

are not always in stock and possibly to take a long period of time for supplying, or in some case
 ed.
 indicate "1" and "1" (i) to avoid mis-supplying.
 s part number can not be supplied.
 * is not illustrated in the exploded view.

have critical characteristics.
 mended by the manufacturer.

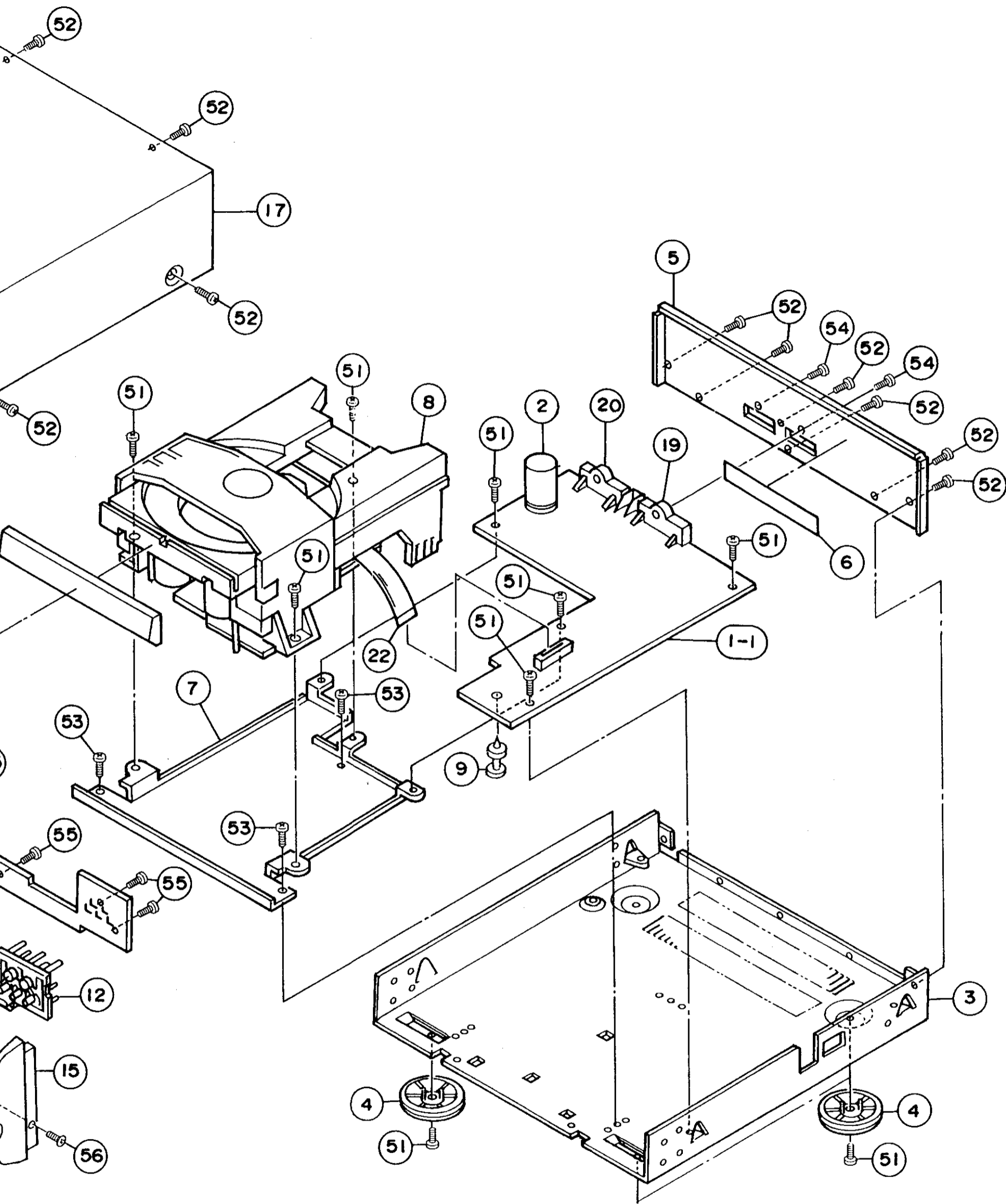

ing, or in some case

PARTS LIST OF CD MECHANISM UNIT
OPTICAL PICK-UP UNIT

MD UNIT

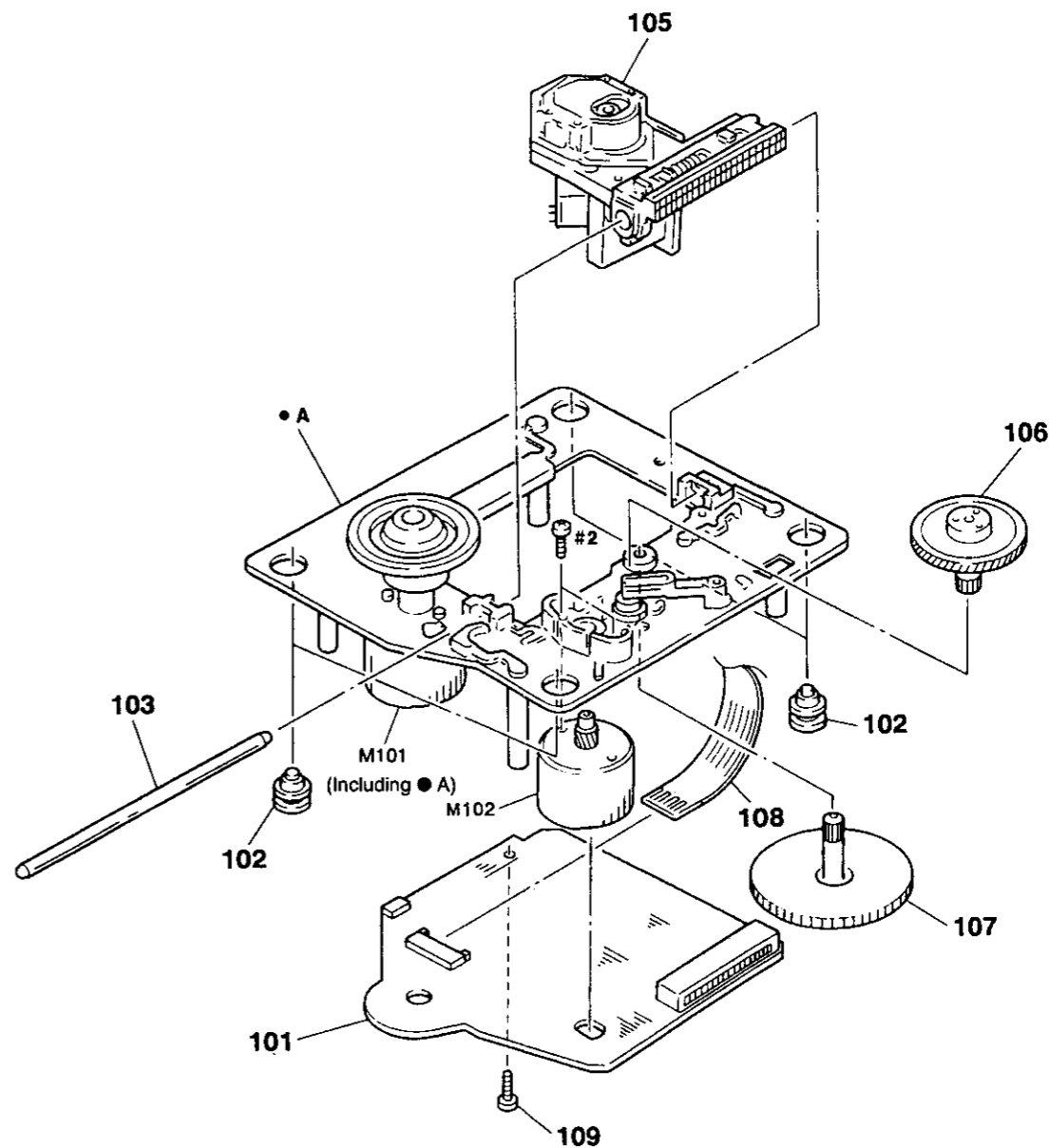
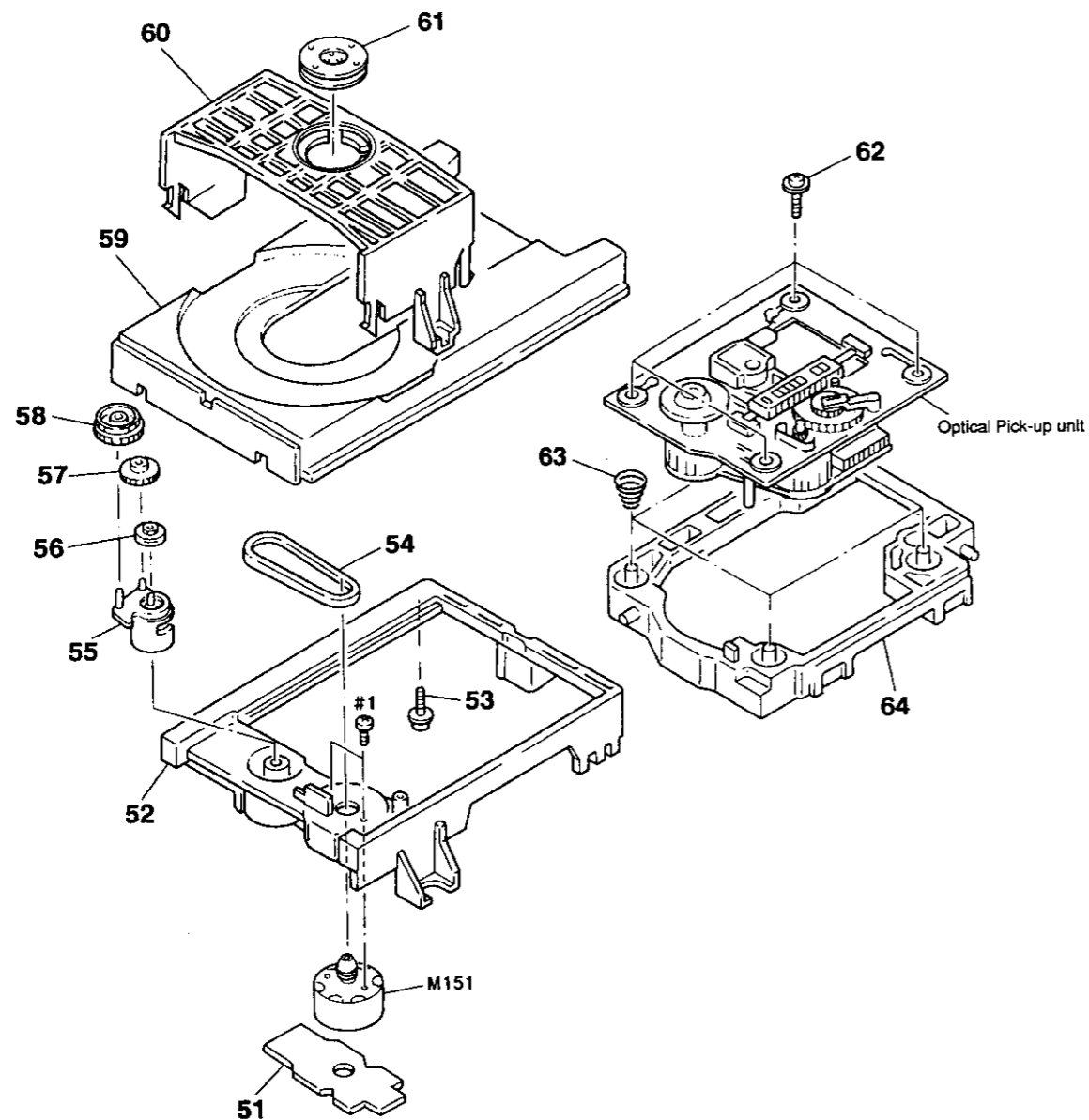

PARTS LIST OF CD MECHANISM UNIT

Ref No.	Part No.	Part Name	Remarks
51	S16 4572 111	Loading P.W.B. Unit Ass'y	See page 28, 29
52	S49 3311 101	Chassis(MD)	
53	S49 1758 321	Yoke Bracket	
54	S49 2764 901	Belt	
55	S49 3310 901	Cam	
56	S49 2765 101	Pulley(S)	
57	S49 2762 801	Gear(C)	
58	S49 3310 701	Gear(PL)	
59	S49 3311 201	Disk Table	
60	S49 3311 001	Holder(MG)	
61	S14 5253 811	Magnet	
62	S49 3313 401	Screw	
63	S49 4850 301	Spring(BU)	
64	S49 3312 901	Holder(BU)	
M151	SA4 6043 63A	Motor(L)Ass'y	
#1	471 3201 024	2.6×4 CBS	

PARTS LIST OF OPTICAL PICK-UP UNIT

Ref No.	Part No.	Part Name	Remarks
⊙ 101	SA4 6494 32A	CD Mechanism P.W.B. Unit Ass'y	See page 28, 29
102	S49 3312 601	Insulator Rubber	
103	S49 1756 501	Sled Shaft	
105	499 0191 009	Optical PU KSS240A	
106	S49 1756 701	Gear(M)	
107	S49 1756 401	Gear(P)	
Ref No.	Part No.	Part Name	Remarks
108	S15 7500 111	Flat Cable	
M101	SX4 9175 233	Motor(Spindle)Ass'y	
M102	SX4 9175 041	Motor(Sled)Ass'y	
109	S49 5162 001	Screw	
#2	471 1810 019	2×3 CPS	

CASSETTE DECK SECTION

DISASSEMBLY PROCEDURES

(Follow these procedures in reverse order to reassemble.)

1. Removing the top cover and front panel

- ① Remove the six screws which fasten the top cover.
- ② Remove the two screws of the bottom side which fasten the front panel.

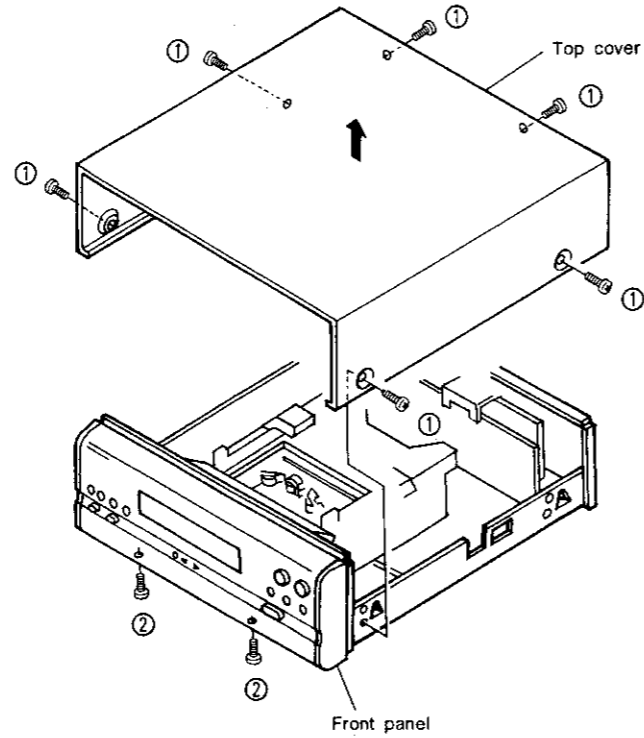

- ③ Remove the two screws which fasten the side plate.
- ④ While disengaging in the direction of the arrow the tabs of the side plate and the holes of the main chassis (with a flat-bladed screwdriver).
- Push out the side plate in the direction of the arrow and remove from the hooks of the inner panel.
- Using the same method for the left side, remove the side plate.
- ⑤ Remove the front panel in the direction of the arrow.

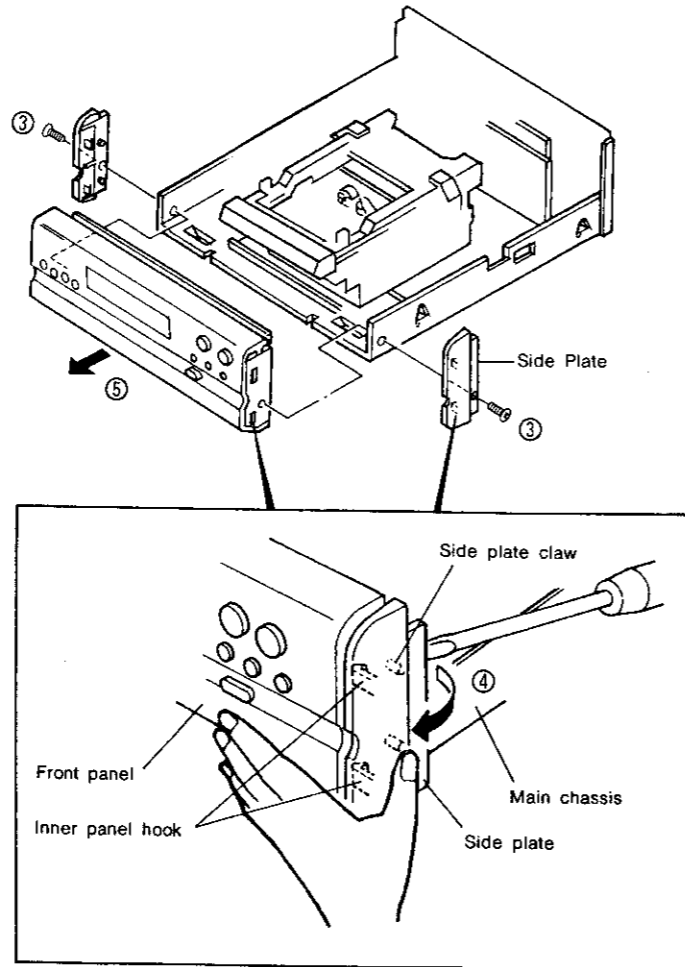

2. Removing the printed wiring units

LED & Tact SW Unit KU-9335-4

- ① Disconnect connector CB401(15P) which is attached to the main unit.
- ② Remove the seven screws which are attached to the control unit.
- ③ Detach the inner panel hook's catch in the direction of the arrow.

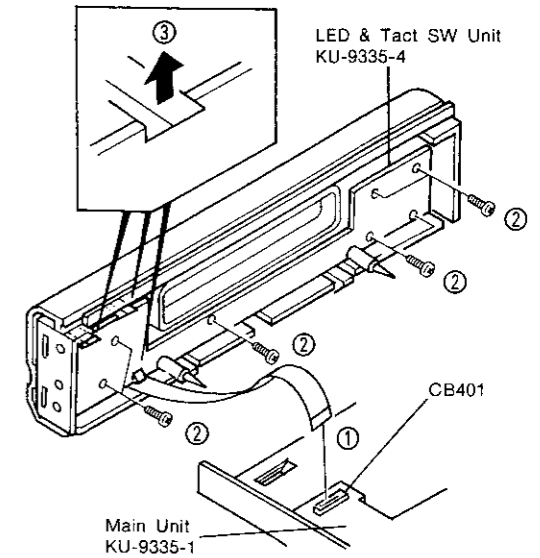

3. Removing the Cassette Mechanism

- ④ Removing the four screws which fasten the cassette mechanism unit.

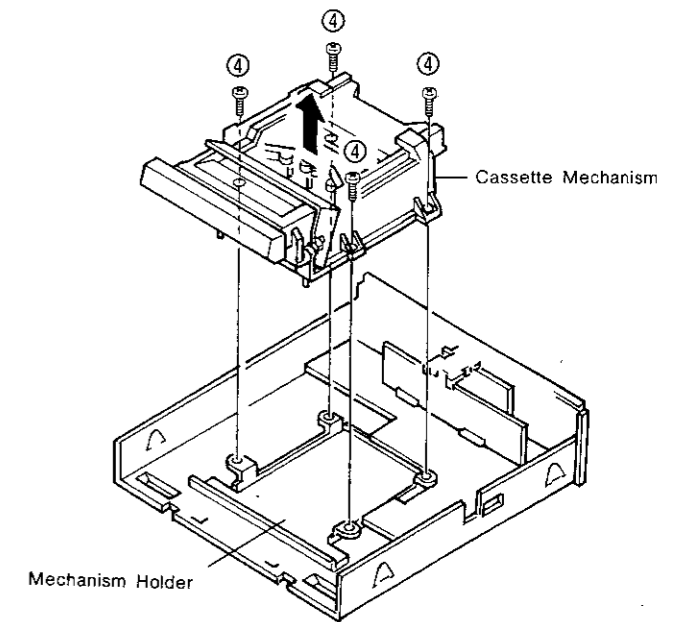

CASSETTE DECK SECTION

- ⑤ Disconnect connectors CB301(4P), CB302(3P), CB501(6P) and CB502(13P) which are attached to the PB R/P unit and the main unit.

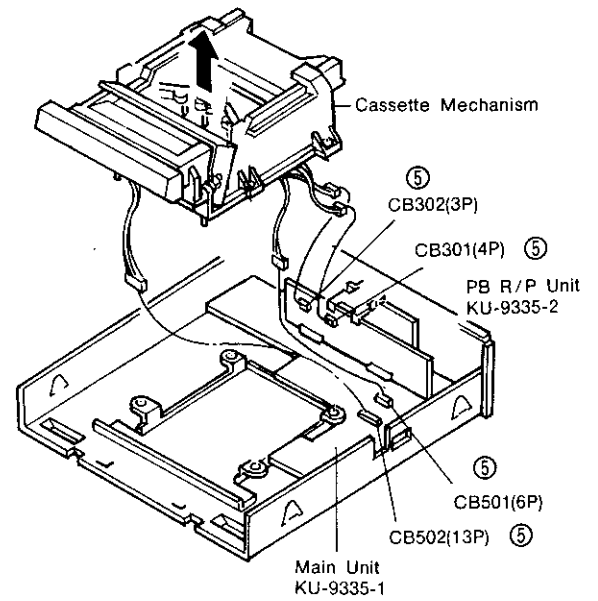
**REC/PB Unit (KU-9335-2)****Dolby Unit (KU-9335-3)**

- ⑥ Remove the four screws of the mounting fitting of the board which is attached to the rear panel.
 ⑦ Remove the RB R/P unit and the Dolby unit.

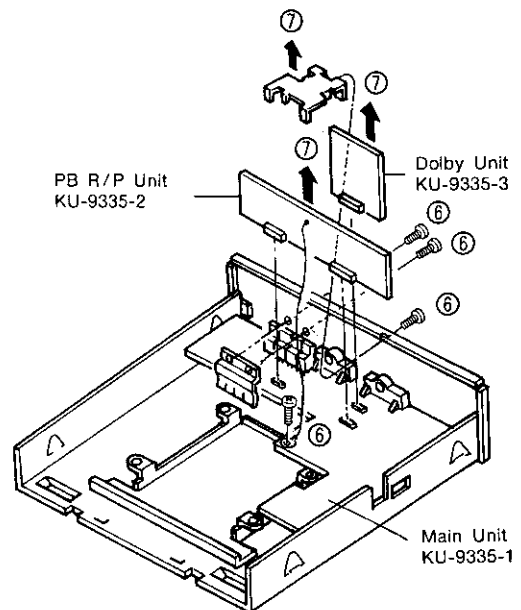
**Main Unit (KU-9335-1)**

- ⑧ Remove the six screws which fasten the main unit and remove the board in the direction of the arrow.

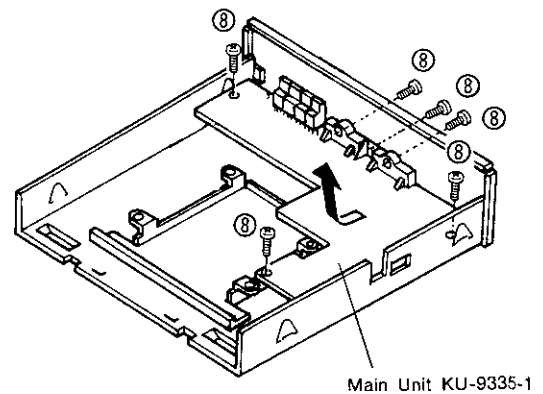

CASSETTE DECK SECTION

LEVEL DIAGRAM

(Recording)

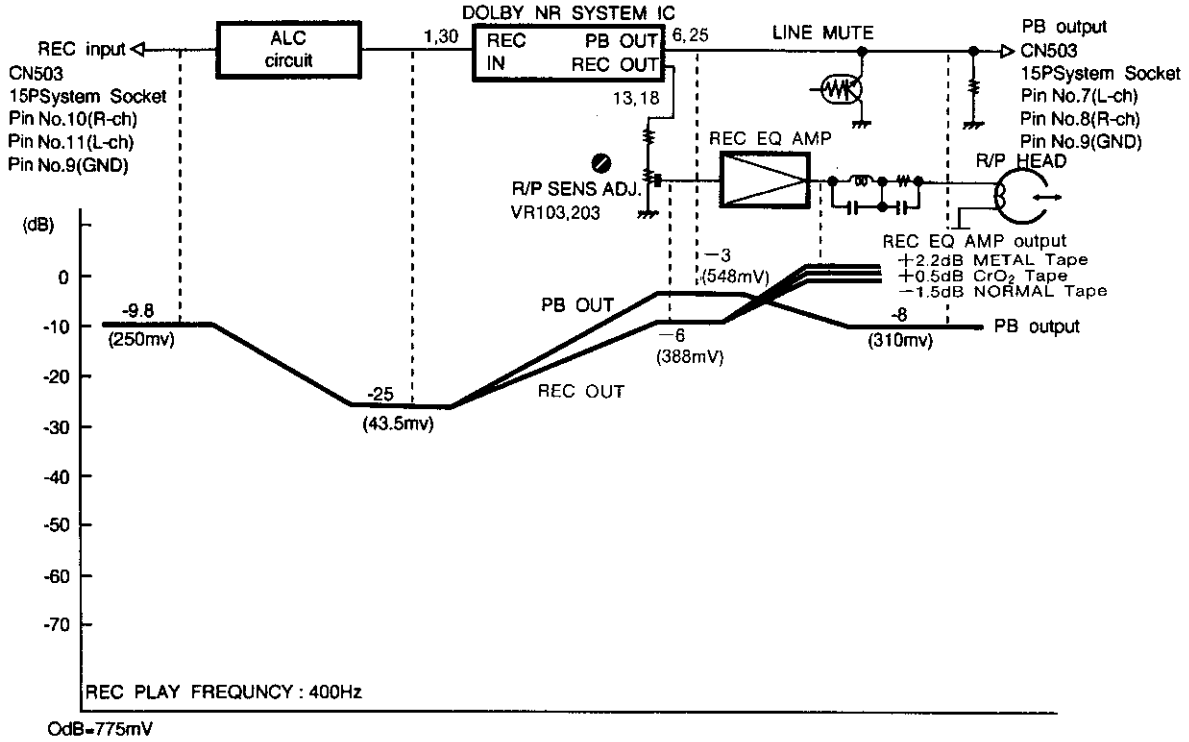

(Playback)

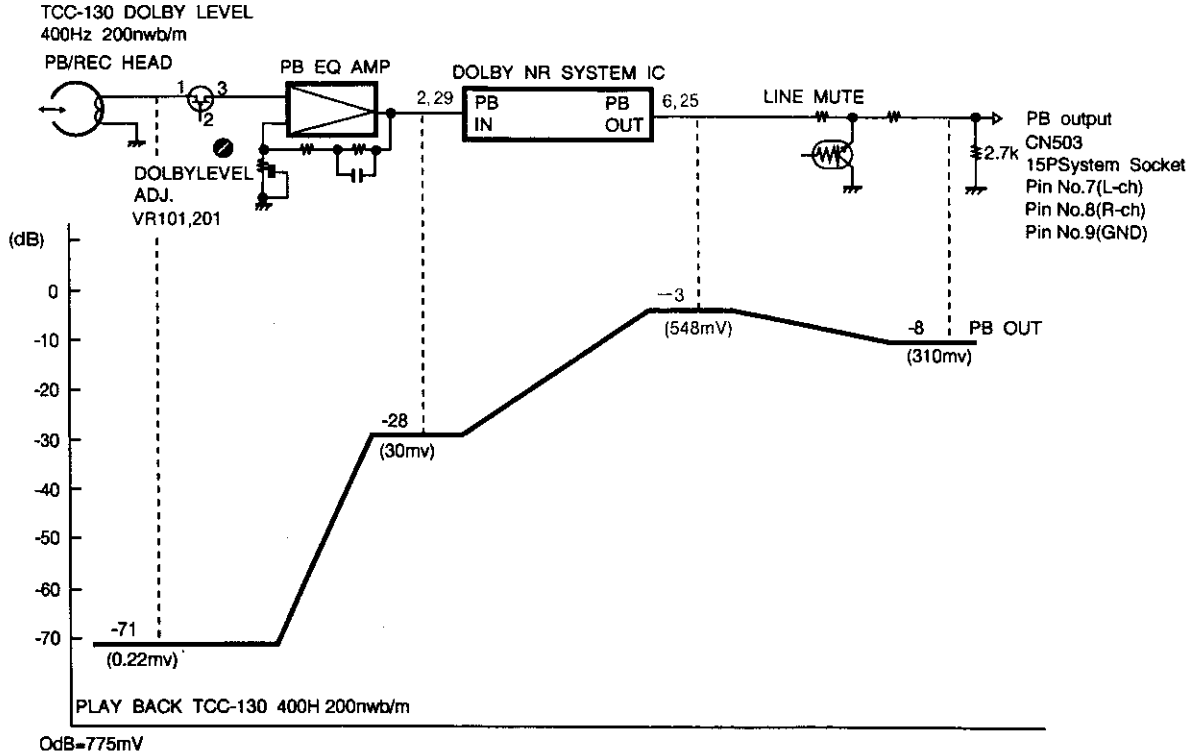

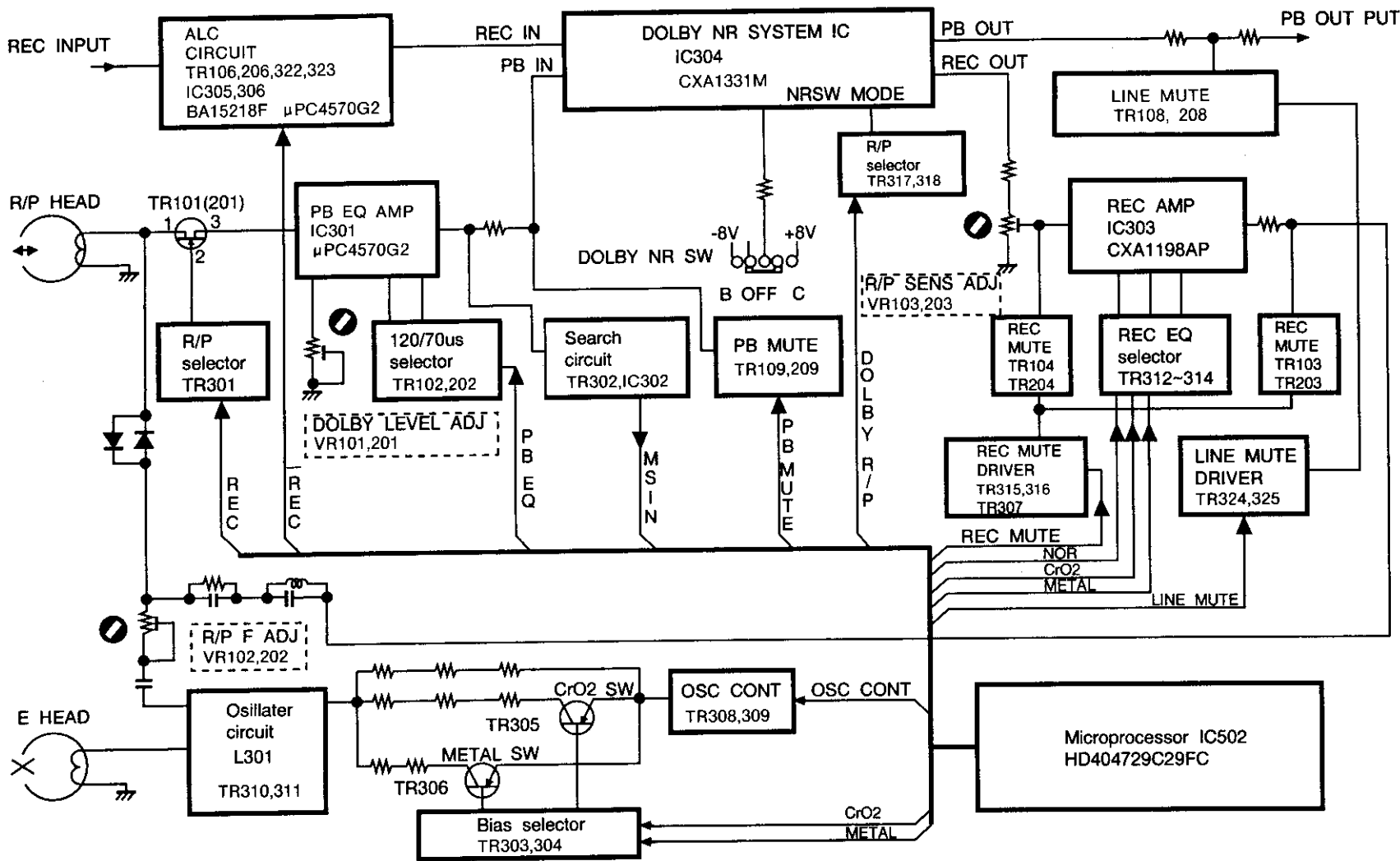

BLOCK DIAGRAM

CASSETTE DECK SECTION

CASSETTE DECK SECTION

ADJUSTMENT

● MECHANISM MEASUREMENTS

Measurement item	Standard value	Remarks
Winding torque (PLAY)	30~60 gcm	SONY TW-2111 for forward, TW-2121 for reverse
Fast-forward and rewind torque	70~120 gcm	SONY TE-2231
Back tension torque	2~6 gcm	SONY TW-2111 for forward, TW-2121 for reverse
Pinch roller pressure	280 ± 42 g	See diagram at right
Fast-forward and rewind time	100 ± 15 sec	C-60

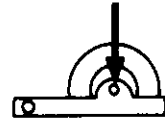

With the deck in the play mode, apply force with the tension gauge in the direction of the arrow and read the value at which the pinch roller stops rotating.

● ELECTRICAL ADJUSTMENTS (UDRA-77 is required for the adjustment of this unit. UCD-77 is not required.)

● Preparations Before Adjustments

1. Measuring Instruments Necessary for Adjustments

- Screwdriver: Small flat-bladed screwdriver for variable resistors
- Low frequency oscillator
- Attenuator
- V.T.V.M.
- Oscilloscope
- Frequency counter
- Test tapes [A-BEX TCC-111, TCC-153, TCC-130, TCC-203B]

● Adjustment notes

- ① Before adjusting, wipe the surface of the heads, the capstans, and the pinch rollers with a piece of gauze moistened with alcohol.
- ② Demagnetize the playback, recording, and erasure heads with a head eraser.
- ③ Completely demagnetize the adjustment screwdriver.
- ④ Unless otherwise specified, set the switches at the following positions and use the AUX/DAT PB Terminal IN jacks for the input. For the output use test point Connector Base TP301 on the KU-9335-3 Dolby Unit.

DOLBY NR SW: OFF

2. Play back adjustments

2-1 Azimuth adjustment

Play back the (A-BEX TCC-153) test tape and turn the azimuth adjustment screw to yield maximum values for the left and right channels.

Lock the screw.

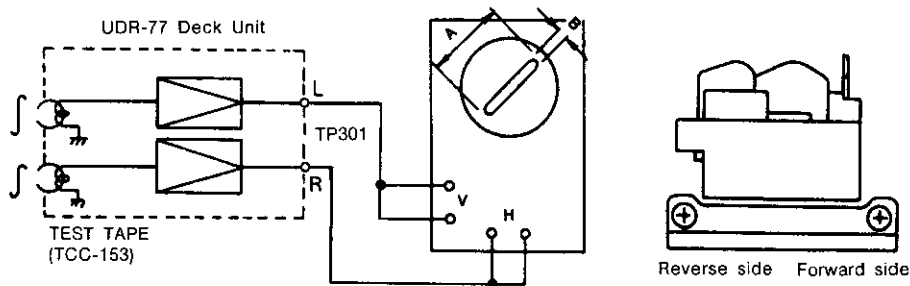

2-2 Tape speed check and adjustment

- Connect the frequency counter to test point TP301.

Play back the test tape (TCC-111) on deck and once tape transport has stabilized, adjust normal-speed-adjustment variable resistor (motor Variable Resistor) to yield 3,000 Hz ±10 Hz

NOTE: Use the central portion of the test tape: not the beginning or end of the winding.

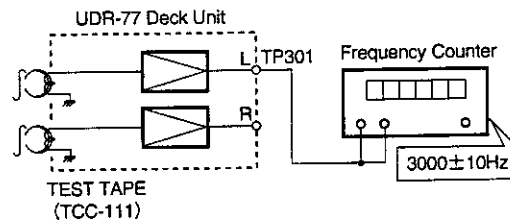

2-3 Playback level check and adjustment

Play a Dolby reference level tape (A-BEX TCC-130) and check that the voltage of the left and right monitor outputs of TP301 on the KU-9335-3 Unit is within 548 mV \pm 1 dB.

NOTE: For anything other than the above, the playback level must be adjusted.

- Adjust: VR101 (Left channel), and VR201 (right channel)

3. Recording adjustments

3-1 Overall frequency response adjustment for recording and playback

Load blank A-BEX TCC-203B tape for adjustment purposes and record and play it back, adjusting the input attenuators of the 1 kHz and 10 kHz signals to yield a left and right monitor output voltage of 54.8 mV at TP301 on the KU-9335-3 Dolby Unit. Adjust so that the 10 kHz level is about +0 dB with respect to 1 kHz, and the overall response is within the range shown in the diagram below.

- If the 10 kHz output is larger than the 1 kHz output, turn VR102 (left channel) and VR202 (right channel) counterclockwise, and if it is smaller, turn these controls clockwise.

3.2 Recording level check and adjustment

Load a blank A-BEX TCC-203B tape for adjustment purposes and check that the voltmeter indication is within the 54.8 mV \pm 1 dB range when a 1 kHz signal is recorded and played back.

If it is not within this range, the recording level requires adjustment.

- If the level at the time of playing back the recording is higher than at the time of recording, turn VR103 (left channel) and VR203 (right channel) counterclockwise, and if lower, turn these controls clockwise.

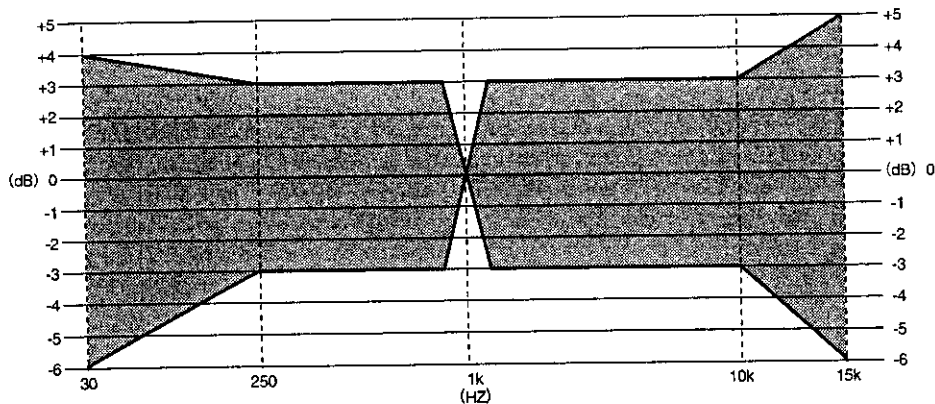

TAPE: A-BEX TCC-203B
DOLBY NR: OFF
at TP301

CASSETTE DECK SECTION

**OUTLINE DIAGRAM OF ADJUSTMENT LOCATION
KU-9335-2 REC/PB UNIT ASS'Y (Component Side)**

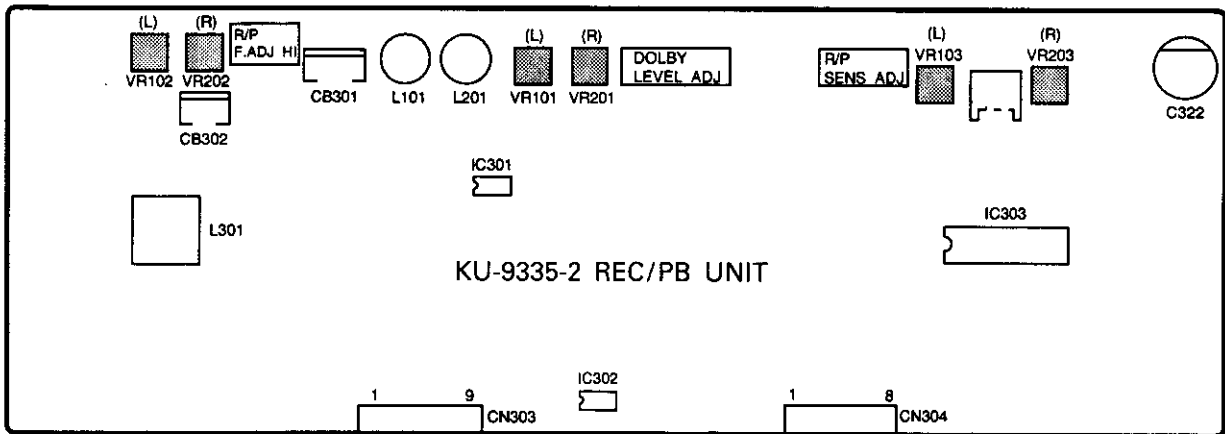

CASSETTE DECK SECTION

SEMICONDUCTORS

IC's

CXA1198AP (IC303)

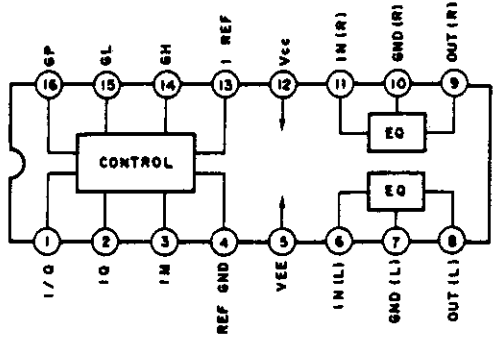
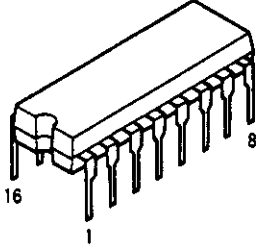

LA2000M (IC302)

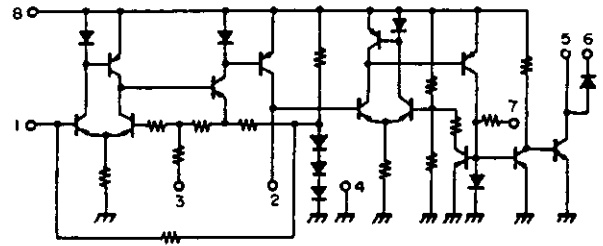
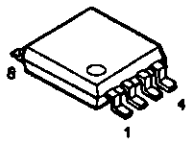

BA6209 (IC501)
Reversible motor driver
(2 circuits built in)

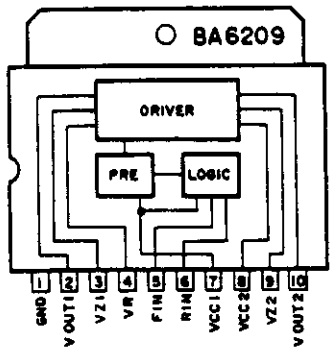
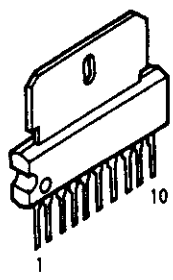

μPC4570G2 (IC301, 306)

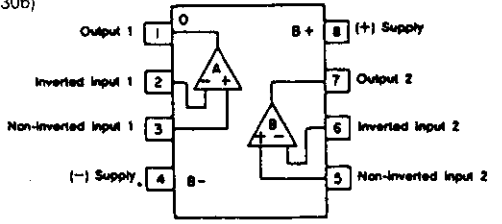
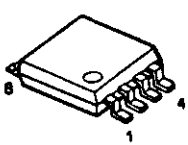

BA15218F (IC305)

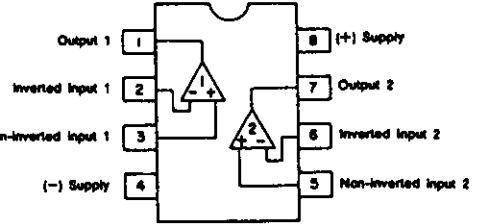
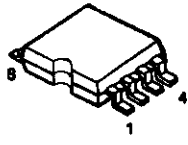

BA178M06 (S) (IC503) .. +6V
BA178M08 (S) (IC504) .. +8V
(Three-terminal positive constant voltage power supply)

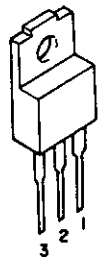

1: Output
2: GND
3: Input

NJM79M08FA (IC505) .. -8V
(Three-terminal negative constant voltage power supply)

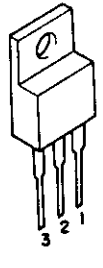

1: Output
2: Input
3: GND

CASSETTE DECK SECTION

CXA1331M (IC304)

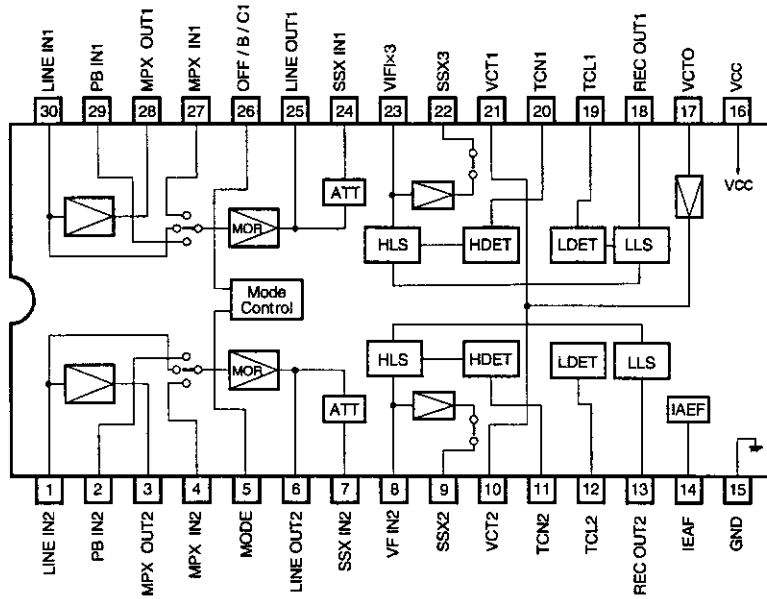
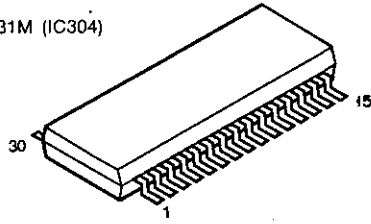

CASSETTE DECK SECTION

● **Transistors**

2SB562 (C)

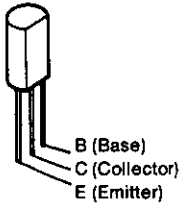

2SA933S (S)

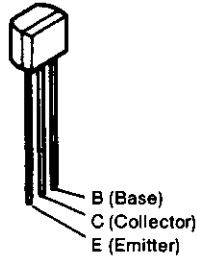

2SK373 (Y) (FET)

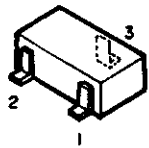
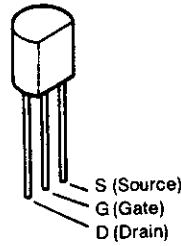

1 : GND / Emitter
2 : In / Base
3 : Out / Collector

PNP Type

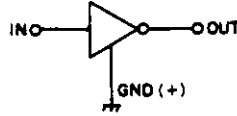
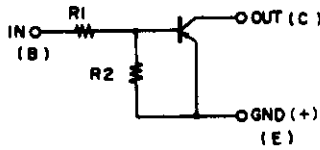

NPN Type

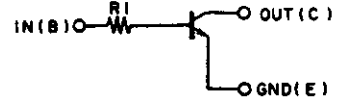

	R1	R2
DTA114EK	10k ohm	10k ohm
DTA144EK	47k ohm	47k ohm

	R1
DTC114TK	10k ohm
DTC323TK	2.2k ohm

NPN Type

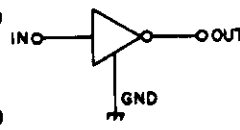
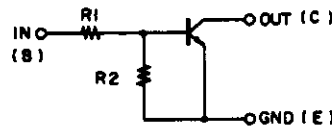

	R1	R2
DTC114EK	10k ohm	10k ohm
DTC144EK	47k ohm	47k ohm

DTA144EK PNP type
DTA114EK }
DTC114EK } NPN type
DTC144EK }
DTC114TK }
DTC323TK }

2SA1037K (S/R)
2SC2412K (S)

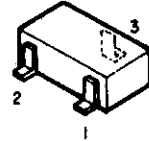

1 : GND / Emitter
2 : In / Base
3 : Out / Collector

● **Diodes**

MTZJ5.6A
MTZJ7.5A
MTZJ7.5C
MTZJ9.1A



1SS252

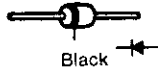

1SR35-200A

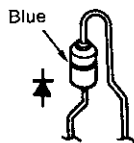

● **LED ASS'Y**

SEL-2410G (Green) (D401, 402)
SEL-2210R (Red) (D403)

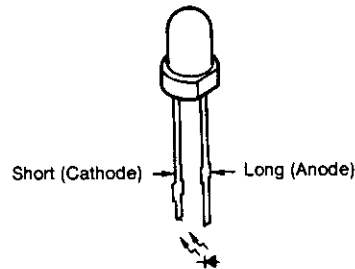

CASSETTE DECK SECTION

MICROPROCESSOR DOCUMENTATION

HD404729C29FS
(IC502) Part No. 262 1867 002

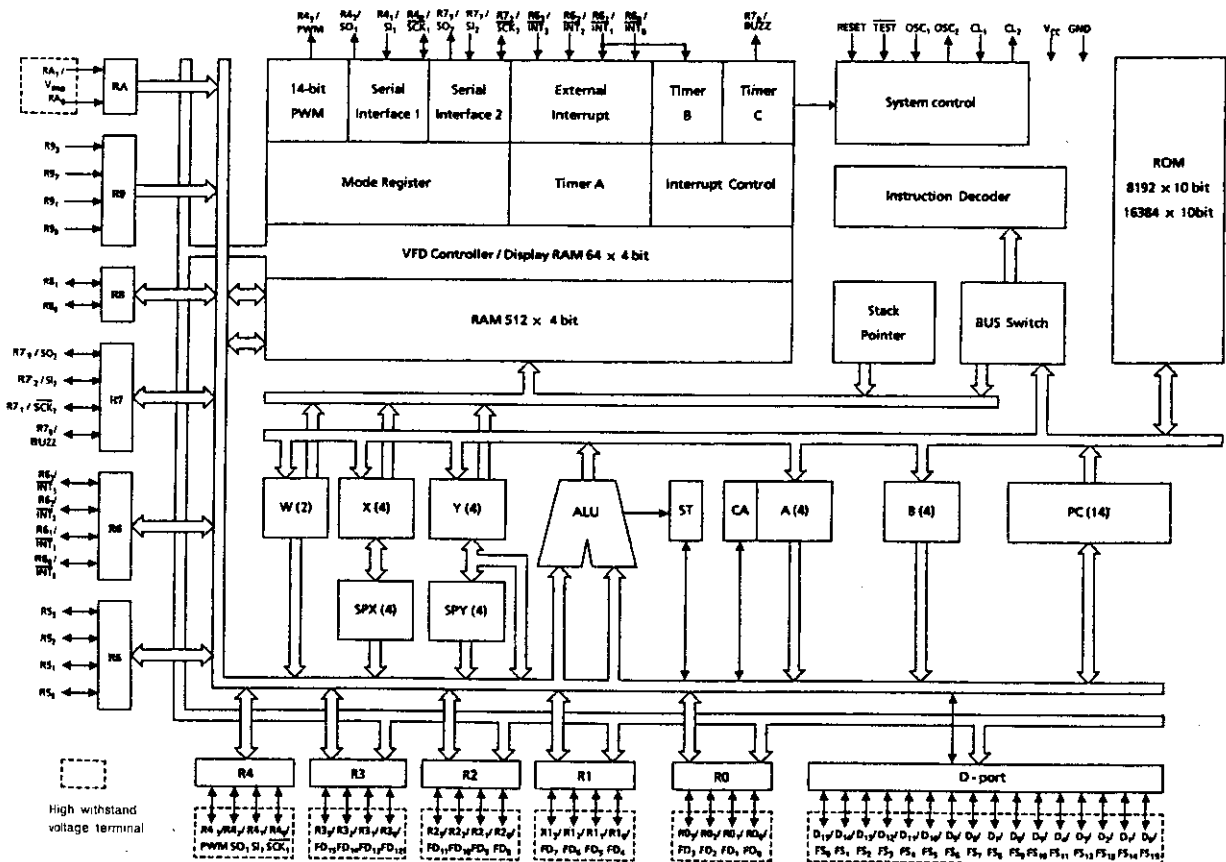
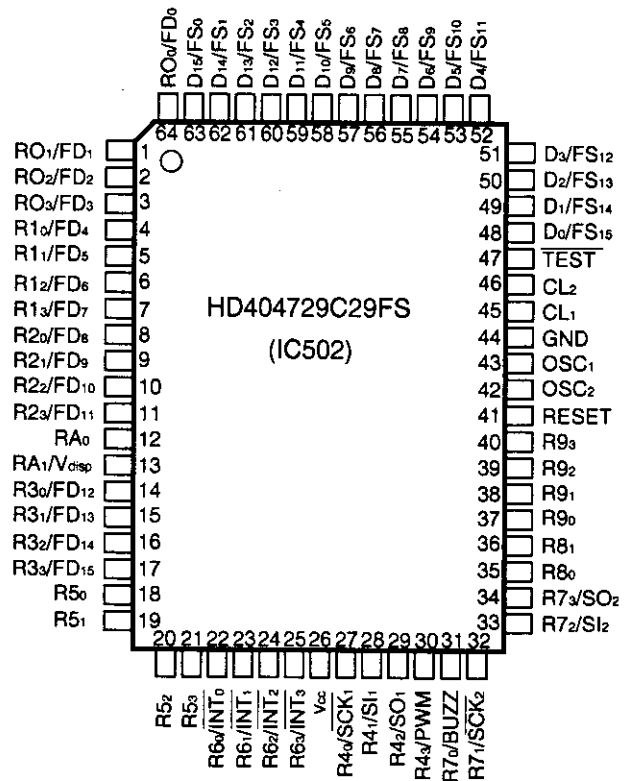
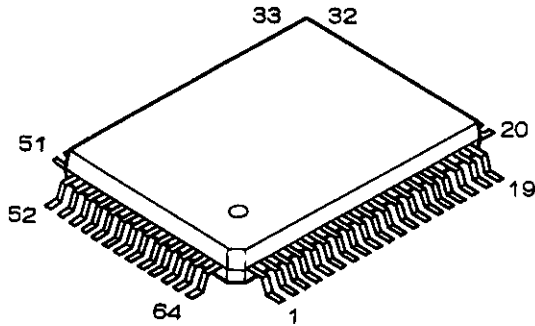

CASSETTE DECK SECTION

• Pin Discription

No.	Port Name	Function Name	Function
1	R01/FD1	CPM OUT	This pin drives the capstan motor of the mechanism. (Active high)
2	R02/FD2	REC MUTE OUT	Mute output pin of the recording amplifier. (Active low)
3	R03/FD3	DOLBY R/P OUT	Output pin that switches the record/playback mode of the Dolby IC.
4	R10/FD4	OPEN OUT	Output pin used to open the loader of the mechanism. (Active high)
5	R11/FD5	CLOSE OUT	Output pin used to close the loader of the mechanism. (Active high)
6	R12/FD6	L.SPEED OUT	Open
7	R13/FD7	OFF ENA OUT	Open
8	R20/FD8	OSC CONT OUT	Output pin that controls the bias oscillation. (Active high)
9	R21/FD9	REC OUT	Record mode output pin; high level during the record mode.
10	R22/FD10	REC OUT	Record out inverted output pin.
11	R23/FD11	PB EQ OUT	Output pin which switches the time constant of the playback amplifier. $120 \mu = H$, $70 \mu = L$
12	RA0	CrO ₂ IN	Mechanism's tape type detection switch input pin.
13	RA1/Vdisp	METAL IN	Mechanism's tape type detection switch input pin.
14	R30/FD12	METAL OUT	Output pin that switches the recording equalizer and the bias to metal. (Active high)
15	R31/FD13	CrO ₂ OUT	Output pin that switches the recording equalizer and the bias to chrome. (Active high)
16	R32/FD14	NORMAL OUT	Output pin that switches the recording equalizer and the bias to normal. (Active high)
17	R33/FD15	PB MUTE OUT	Mute output pin of the playback amplifier. (Active high)
18	R50	NC (OUT)	Open
19	R51	NC (OUT)	Open
20	R52	NC (OUT)	Open
21	R53	SERIAL SIG OUT	Output pin used for serial communications. (Active low)
22	R60/INT0	SERIAL SIG IN	Input pin used for serial communications. (Active low)
23	R61/INT1	STANDBY IN	This pin sets the microprocessor to the standby mode.
24	R62/INT2	ENA IN	Display data output enable input pin.
25	R63/INT3	MS IN	Input pin for the intertrack detection signal from the IC used for intertrack detection. (Active low)
26	Vcc	Vcc	Power supply input pin.
27	R40/SCK1	CLOCK OUT	Clock pulse output pin used for display data transfer.
28	R41/SI1	NC (OUT)	Open
29	R42/SO2	DATA OUT	Display data output pin.
30	R43/PWM	LINE MUTE OUT	Mute output pin of the playback output pin.
31	R70/BUZZ	NC (OUT)	Open
32	R71/SCK2	NC (OUT)	Open
33	R72/SI2	NC (OUT)	Open
34	R73/SO2	NC (OUT)	Open
35	R80	NC (OUT)	Open
36	R81	NC (OUT)	Open
37	R90	KR0	Key and switch input pin.
38	R91	KR1	Key and switch input pin.
39	R92	KR2	Key and switch input pin.
40	R93	KR3	Key and switch input pin.
41	RESET	RESET IN	System reset input pin.
42	OSC2	OSC2	System clock oscillation pin. 4 MHz
43	OSC1	OSC1	System clock oscillation pin. 4 MHz
44	GND	GND	Ground pin.
45	CL1	CL1	Connect to ground.

CASSETTE DECK SECTION

No.	Port Name	Function Name	Function
46	CL2	CL2	Open
47	TEST	TEST	Connect to Vcc.
48	D0/FS15	KS0	Key strobe output pin.
49	D1/FS14	KS1	Key strobe output pin.
50	D2/FS13	KS2	Key strobe output pin.
51	D3/FS12	KS3	Key strobe output pin.
52	D4/FS11	KS4	Key strobe output pin.
53	D5/FS10	KS5	Key strobe output pin.
54	D6/FS9	KS6	Key strobe output pin.
55	D7/FS8	POWER ON OUT	Open
56	D8/FS7	REV LED OUT	REVERSE LED lighting output.
57	D9/FS6	FWD LED OUT	FORWARD LED lighting output.
58	D10/FS5	REC LED OUT	REC LED lighting output.
59	D11/FS4	NC (OUT)	Open
60	D12/FS3	NC (IN)	Connect to Vcc.
61	D13/FS2	NC (OUT)	Open
62	D14/FS1	REEL S IN	Reel pulse input pin of the supply side.
63	D15/FS0	REEL T IN	Reel pulse input pin of the take-up side.
64	R00/FD0	PLAY SOL OUT	Output pin that drives the solenoid of the mechanism.

CASSETTE DECK SECTION

• Button Input Description

Item	Button Name	Description of Function
1	F. PLAY	Commands the forward direction play mode. Commands the cue/revue mode with one-touch play operations of PLAY + REW/FF, or FF/REW during the play mode.
2	R. PLAY	Commands the play mode of the reverse direction. The one-touch play operations of the cue/revue mode are the same as with F. PLAY.
3	F. F	Commands the tape to be wound quickly in the right direction.
4	REW	Commands the tape to be wound quickly in the left direction.
5	STOP	Commands the stop mode. When there has been input from this button, there will be a change to the stop mode from whichever mode is currently set.
6	OPEN/CLOSE	Commands the open/close mode of the cassette tray. The open/close mode is switched cyclicly with the input of this button. This is a toggle operation. When there is input from this button with the power off, the power is switched on and there is then a shift to the open mode.
7	REC/REC MUTE	Commands the record, record pause, and record muting modes. When there is button input in the stop mode, there will be a shift to the record pause mode. When there is button input in the record pause mode, there will be a shift to the record mute mode. When switched on simultaneously with PLAY, or when there is PLAY button input in the record pause mode, there will be a shift to the record mode. The conditions of the record mode must be satisfied.
8	COUNTER RESET	Resets the counter to "0000".
9	MEMORY STOP	Stops when the counter reaches "0000".
10	CD SRS	Commands the CS SRS operation.

• Switch Input Description

Item	Switch Name	Description of Function
1	REVERSE	Commands the one side or two side recording/playback modes and the endless playback mode.
2	DOLBY NR	Commands the on/off switching of the Dolby (B/C) noise reduction circuit.

MICROPROCESSOR PERIPHERAL WIRING DIAGRAM

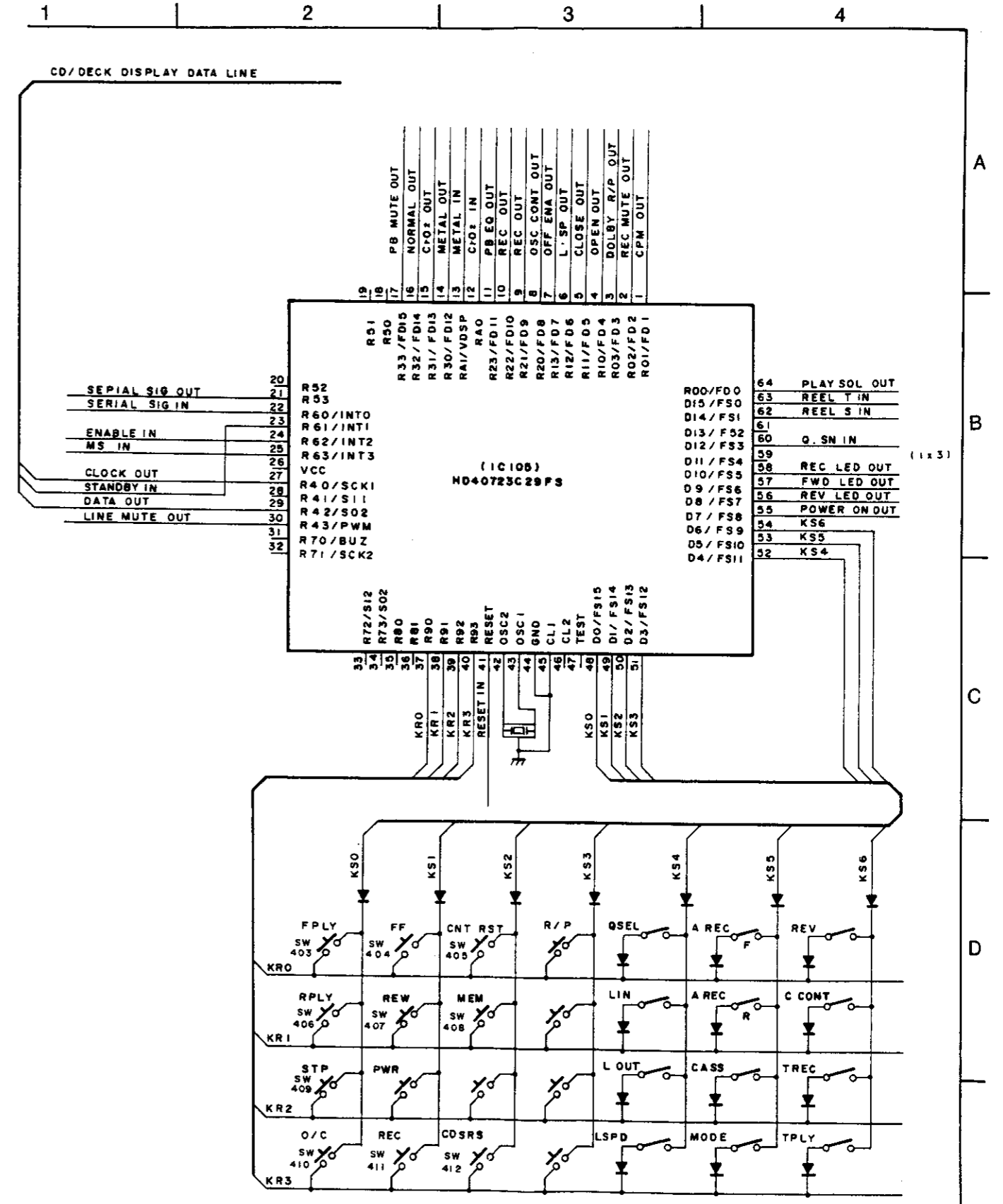

CASSETTE DECK SECTION

PRINTED WIRING BOARD

1 2 3 4 5 6 7 8

KU-9335 DECK UNIT ASS'Y

Component Side

KU-9335 DECK UNIT ASS'Y	
1	MAIN UNIT
2	REC/PB UNIT
3	LED, CONTROL UNIT
4	DOLBY UNIT

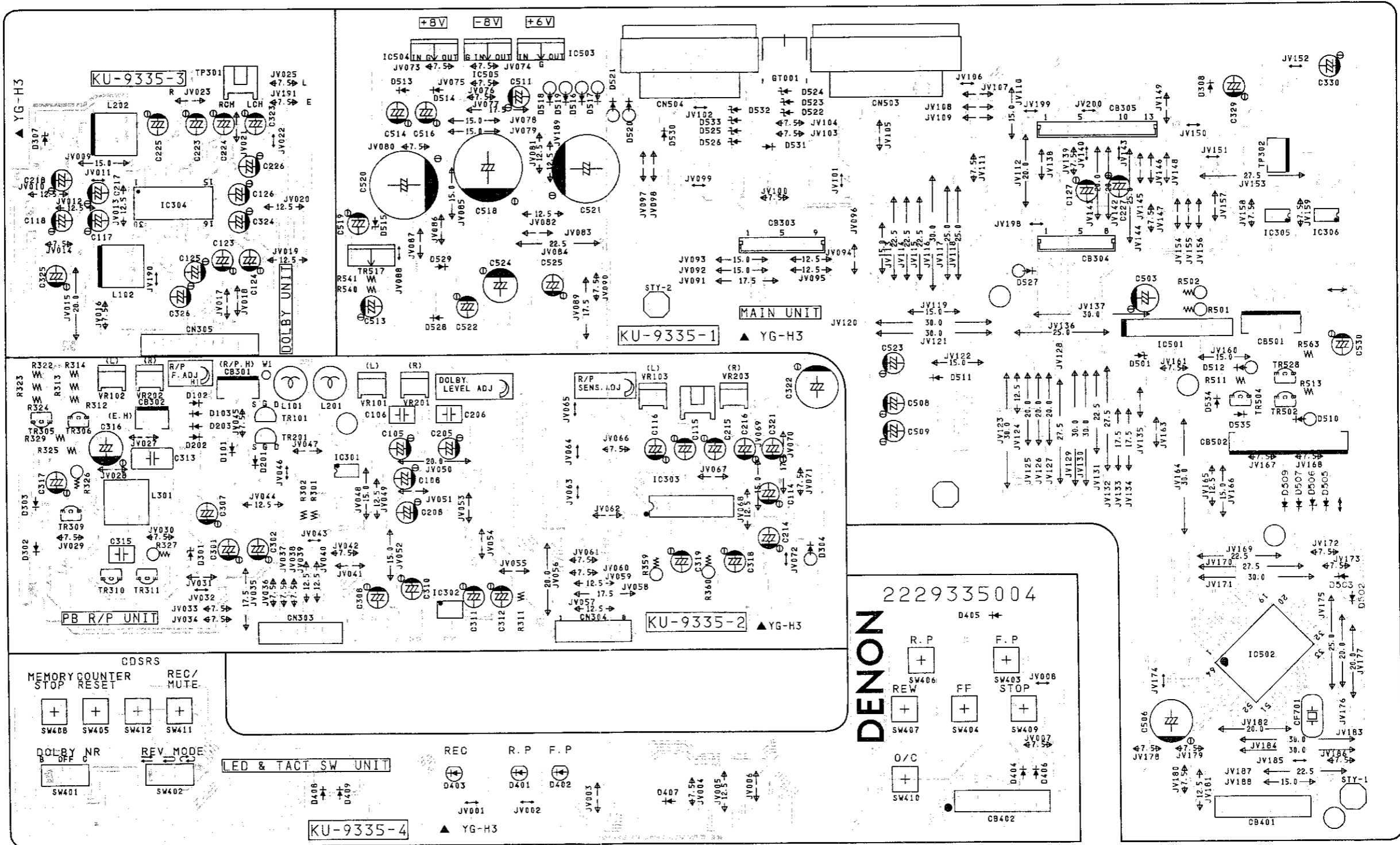

A

B

C

D

E

CASSETTE DECK SECTION

1 2 3 4 5 6 7 8

Patern Side

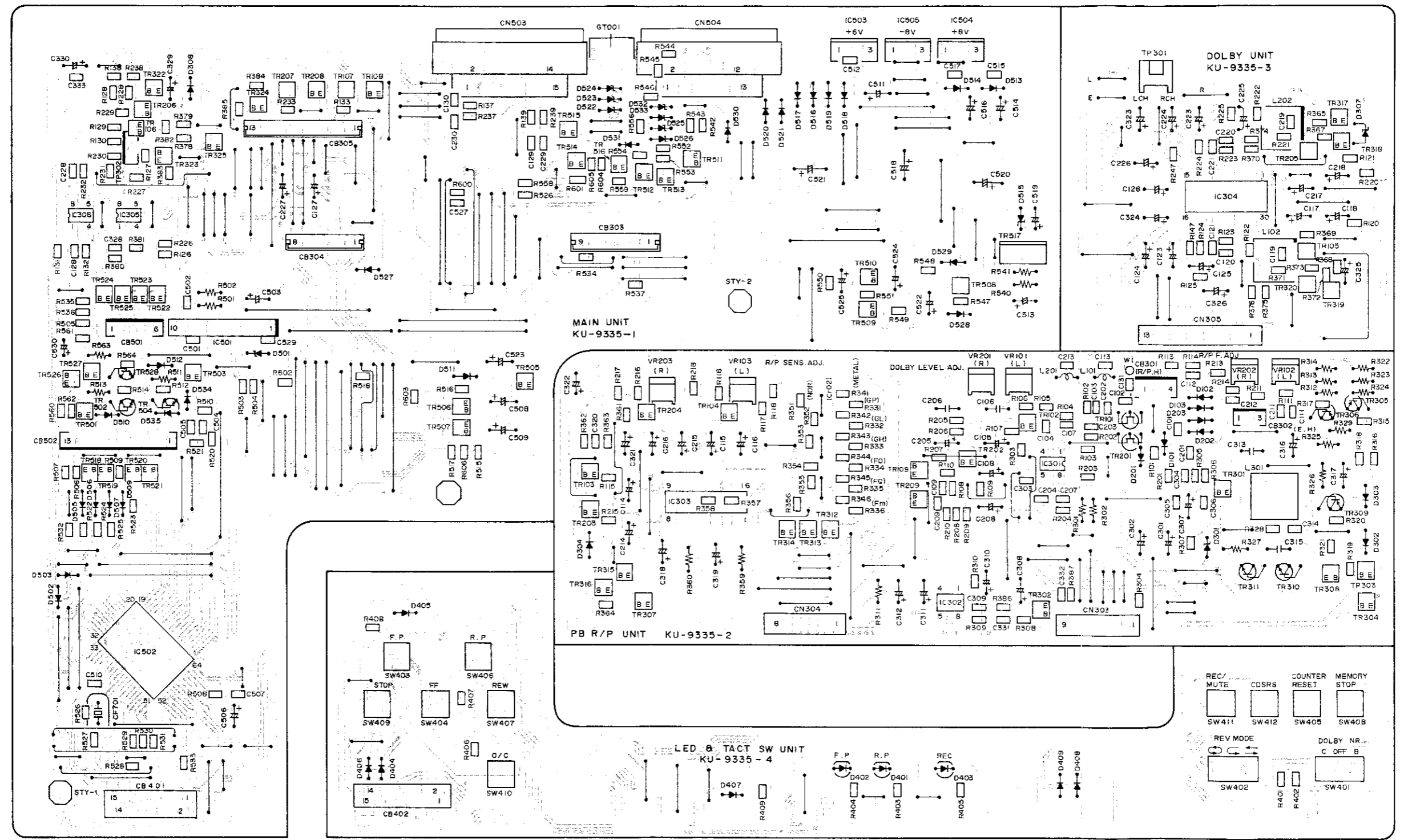

A
B
C
D
E

CASSETTE DECK SECTION

NOTE ON PARTS LIST

- Part indicated with the mark "●" are not always in stock and possibly to take a long period of time for supplying, or in some case supplying of part may be refused.
- When ordering of part, clearly indicate "1" and "1" (i) to avoid mis-supplying.
- Ordering part without stating its part number can not be supplied.
- Part indicated with the mark "★" is not illustrated in the exploded view.
- Not including Carbon Film ±5%, 1/4 W Type in the P.W. Board parts list. (Refer to the Schematic Diagram for those parts.)

WARNING:

Parts marked with this symbol  have critical characteristics. Use ONLY replacement parts recommended by the manufacturer.

Resistors

Ex.: **RN 14K 2E 182 G FR**
 Type Shape and performance Power Resistance Allowable error Others

RD : Carbon Film	2B : 1/8W	F : ±1%	P : Pulse-resistant type
RC : Composition	2E : 1/4W	G : ±2%	NL : Low noise type
RS : Metallic oxide Film	2H : 1/2W	J : ±5%	NB : Non-burning type
RW : Winding	3A : 1W	K : ±10%	FR : Fuse-resistor
RN : Metal film	3D : 2W	M : ±20%	F : Lead wire forming
RK : Metal mixture	3F : 3W		
RM : Carbon chip	3H : 5W		

*** Resistance**

1 8 2 ⇒ 1800 ohm = 1.8 kohm
 Indicates number of zeros after effective number
 2-digit effective number

• Units: ohm

1 R 2 ⇒ 1.2 ohm
 1-digit effective number.
 2-digit effective number, decimal point indicated by R.

• Units: ohm

*** Capacity (electrolyte only)**

2 2 2 ⇒ 2200 μF
 Indicates number of zeros after effective number.
 2-digit effective number.

• Units: μF

2 R 2 ⇒ 2.2 μF
 1-digit effective number.
 2-digit effective number, decimal point indicated by R.

• Units: μF

Capacitors

Ex.: **CE 04W 1H 2R2 M BP**
 Type Shape and performance Dielectric strength Capacity Allowable error Others

CE : Aluminum foil electrolyte	DJ : 6.3V	F : ±1%	HS : High stability type
CA : Aluminum solid electrolyte	1A : 10V	G : ±2%	BP : Non-polar type
CS : Tantalum electrolyte	1C : 16V	J : ±5%	HR : Ripple-resistant type
CO : Film	1E : 25V	K : ±10%	DL : For charge and discharge
CK : Ceramic	1V : 35V	M : ±20%	HF : For assuring high frequency
CC : Ceramic	1H : 50V	Z : +80%	U : UL part
CP : Oil	2A : 100V	-20%	C : CSA part
CM : Mica	2B : 125V	P : +100%	W : UL-CSA type
CF : Metallized	2C : 160V	-0%	F : Lead wire forming
CH : Metallized	2D : 200V	C : ±0.25pF	
	2E : 250V	D : ±0.5pF	
	2H : 500V	-	
	2J : 630V		

*** Capacity (except electrolyte)**

2 2 2 ⇒ 2200 pF = 2200 μF = 0.0022 μF
 (More than 2) Indicates number of zeros after effective number.
 2-digit effective number.

• Units: μF

2 2 1 ⇒ 220 pF
 (0 or 1) Indicates number of zeros after effective number.
 2-digit effective number.

• Units: pF

• When the dielectric strength is indicated in AC, "AC" is included after the dielectric strength value.

KU-9335 DECK UNIT ASS'Y PARTS LIST

Ref. No.	Part No.	Part Name	Remarks	Ref. No.	Part No.	Part Name	Remarks
SEMICONDUCTORS GROUP				RESISTORS GROUP (Not included Carbon Film ±5%, 1/4W Type. Refer to the Schematic Diagram for those Parts.)			
IC301	263 0674 901	UPC4570G2-E2		D201~203	276 0616 907	1SS252T-77	
IC302	263 1022 905	LA2000M-TE-L		D301	276 0643 996	MTZJ5.6A T77	
IC303	263 0589 009	CXA1198AP		D302,303	276 0616 907	1SS252T-77	
IC304	262 1267 903	CXA1331M-T6		D304	276 0553 905	1SR35-200A	
IC305	263 0615 902	BA15218F(TAPE)		D307	276 0644 937	MTZJ9.1A T77	
IC306	263 0674 901	UPC4570G2-E2		D308	276 0616 907	1SS252T-77	
IC501	263 0402 005	BA6209		D401,402	393 9409 902	SEL-2410G(TPI)	
IC502	262 1867 002	HD404729C29FS	μ-com	D403	393 9401 900	SEL2210R(TPI)	
IC503	263 1010 001	BA178M06	Regulator +6V	D404~409	276 0616 907	1SS252T-77	
IC504	263 1023 001	BA178M08	Regulator +8V	D501	276 0635 904	MTZJ7.5CT77	
IC505	263 0511 006	NJM79M08FA	Regulator -8V	D502,503	276 0616 907	1SS252T-77	
TR101	275 0042 905	FET2SK373(Y)		D505~507,509	276 0616 907	1SS252T-77	
TR102	271 0238 908	Transistor 2SA1037K(S/R)		D510	276 0553 905	1SR35-200A	
TR103	269 0066 902	Transistor DTC323TK	Built in Resistor	D511	276 0616 907	1SS252T-77	
TR104	273 0384 900	Transistor 2SC2412K(S)		D512	276 0553 905	1SR35-200A	
TR106	273 0384 900	Transistor 2SC2412K(S)		D513,514	276 0616 907	1SS252T-77	
TR108	269 0066 902	Transistor DTC323TK	Built in Resistor	D516~521	276 0553 905	1SR35-200A	
TR109	273 0384 900	Transistor 2SC2412K(S)		D522~526	276 0635 904	MTZJ7.5CT77	
TR201	275 0042 905	FET 2SK373(Y)		D527	276 0553 905	1SR35-200A	
TR202	271 0238 908	Transistor 2SA1037K(S/R)		D529~531	276 0616 907	1SS252T-77	
TR203	269 0066 902	Transistor DTC323TK	Built in Resistor	D532	276 0635 904	MTZJ7.5CT77	
TR204	273 0384 900	Transistor 2SC2412K(S)		D533	276 0644 911	MTZJ7.5A T77	
TR206	273 0384 900	Transistor 2SC2412K(S)		D534,535	276 0616 907	1SS252T-77	
TR208	269 0066 902	Transistor DTC323TK	Built in Resistor				
TR209	273 0384 900	Transistor 2SC2412K(S)					
TR301	269 0083 901	Transistor DTA114EK	Built in Resistor	R101	247 0015 940	Chip Carbon 2.2 Mohm 1/10W	RM73B--225J
TR302	273 0384 900	Transistor 2SC2412K(S)		R102	247 0011 960	Chip Carbon 56 kohm 1/10W	RM73B--563J
TR303,304	269 0082 902	Transistor DTC114EK	Built in Resistor	R103	247 0005 905	Chip Carbon 100 ohm 1/10W	RM73B--101J
TR305,306	271 0192 905	Transistor 2SA933S(S)		R104	247 0013 926	Chip Carbon 270 kohm 1/10W	RM73B--274J
TR307,308	269 0082 902	Transistor DTC114EK	Built in Resistor	R105	247 0010 945	Chip Carbon 18 kohm 1/10W	RM73B--183J
TR309	271 0192 905	Transistor 2SA933S(S)		R106	247 0010 974	Chip Carbon 24 kohm 1/10W	RM73B--243J
TR310,311	273 0303 910	Transistor 2SC1740S(S)		R107	247 0009 985	Chip Carbon 10 kohm 1/10W	RM73B--103J
TR312~314	269 0082 902	Transistor DTC114EK	Built in Resistor	R108,109	247 0011 944	Chip Carbon 47 kohm 1/10W	RM73B--473J
TR315	269 0083 901	Transistor DTA114EK	Built in Resistor	R110	247 0009 914	Chip Carbon 5.1 kohm 1/10W	RM73B--512J
TR316~318	269 0082 902	Transistor DTC114EK	Built in Resistor	R111	247 0013 968	Chip Carbon 390 kohm 1/10W	RM73B--394J
TR322,323	273 0384 900	Transistor 2SC2412K(S)		R113	247 0018 905	Chip Carbon 0 ohm 1/10W	RM73B--0R0K
TR324	269 0083 901	Transistor DTA114EK	Built in Resistor	R114	247 0009 985	Chip Carbon 10 kohm 1/10W	RM73B--103J
TR325	269 0054 901	Transistor DTC144EK	Built in Resistor	R115	247 0005 905	Chip Carbon 100 ohm 1/10W	RM73B--101J
TR501	269 0088 906	Transistor DTC114TK	Built in Resistor	R116	247 0007 945	Chip Carbon 1 kohm 1/10W	RM73B--102J
TR502	272 0025 907	Transistor 2SB562(C)		R117	247 0009 927	Chip Carbon 5.6 kohm 1/10W	RM73B--562J
TR503	269 0088 906	Transistor DTC114TK	Built in Resistor	R118	247 0009 956	Chip Carbon 7.5 kohm 1/10W	RM73B--752J
TR504	272 0025 907	Transistor 2SB562(C)		R120,121	247 0007 945	Chip Carbon 1 kohm 1/10W	RM73B--102J
TR505	269 0054 901	Transistor DTC144EK	Built in Resistor	R123	247 0010 974	Chip Carbon 24 kohm 1/10W	RM73B--243J
TR506,507	271 0238 908	Transistor 2SA1037K(S/R)		R124	247 0006 988	Chip Carbon 560 ohm 1/10W	RM73B--561J
TR509	269 0083 901	Transistor DTA114EK	Built in Resistor	R125	247 0011 944	Chip Carbon 47 kohm 1/10W	RM73B--473J
TR510	273 0384 900	Transistor 2SC2412K(S)		R126	247 0012 927	Chip Carbon 100 kohm 1/10W	RM73B--104J
TR511	269 0054 901	Transistor DTC144EK	Built in Resistor	R127	247 0009 901	Chip Carbon 4.7 kohm 1/10W	RM73B--472J
TR512	269 0082 902	Transistor DTC114EK	Built in Resistor	R128	247 0012 927	Chip Carbon 100 kohm 1/10W	RM73B--104J
TR513	269 0054 901	Transistor DTC144EK	Built in Resistor	R129	247 0006 962	Chip Carbon 470 ohm 1/10W	RM73B--471J
TR514	271 0238 908	Transistor 2SA1037K(S/R)		R130	247 0014 967	Chip Carbon 1 Mohm 1/10W	RM73B--105J
TR515	269 0082 902	Transistor DTC114EK	Built in Resistor	R131	247 0007 974	Chip Carbon 1.3 kohm 1/10W	RM73B--132J
TR516	271 0238 908	Transistor 2SA1037K(S/R)		R132	247 0010 945	Chip Carbon 18 kohm 1/10W	RM73B--183J
TR518~521	269 0083 901	Transistor DTA114EK	Built in Resistor	R133	247 0008 915	Chip Carbon 2 kohm 1/10W	RM73B--202J
TR522,523	269 0054 901	Transistor DTC144EK	Built in Resistor	R137	247 0006 917	Chip Carbon 300 ohm 1/10W	RM73B--301J
TR524,525	269 0055 900	Transistor DTA144EK	Built in Resistor	R138	247 0009 901	Chip Carbon 4.7 kohm 1/10W	RM73B--472J
TR526	269 0088 906	Transistor DTC114TK	Built in Resistor	R139	247 0002 966	Chip Carbon 10 ohm 1/10W	RM73B--100J
TR527	273 0384 900	Transistor 2SC2412K(S)		R147	247 0007 945	Chip Carbon 1 kohm 1/10W	RM73B--102J
TR528	272 0025 907	Transistor 2SB562(C)		R201	247 0015 940	Chip Carbon 2.2 Mohm 1/10W	RM73B--225J
D101~103	276 0616 907	1SS252T-77		R202	247 0011 960	Chip Carbon 56 kohm 1/10W	RM73B--563J
				R203	247 0005 905	Chip Carbon 100 ohm 1/10W	RM73B--101J
				R204	247 0013 926	Chip Carbon 270 kohm 1/10W	RM73B--274J
				R205	247 0010 945	Chip Carbon 18 kohm 1/10W	RM73B--183J
				R206	247 0010 974	Chip Carbon 24 kohm 1/10W	RM73B--243J
				R207	247 0009 985	Chip Carbon 10 kohm 1/10W	RM73B--103J

CASSETTE DECK SECTION

Ref. No.	Part No.	Part Name	Remarks	Ref. No.	Part No.	Part Name	Remarks
R208,209	247 0011 944	Chip Carbon 47 kohm 1/10W	RM73B--473J	R376	247 0010 961	Chip Carbon 22 kohm 1/10W	RM73B--223J
R210	247 0009 914	Chip Carbon 5.1 kohm 1/10W	RM73B--512J	R378	247 0009 985	Chip Carbon 10 kohm 1/10W	RM73B--103J
R211	247 0013 968	Chip Carbon 390 kohm 1/10W	RM73B--394J	R379	247 0013 900	Chip Carbon 220 kohm 1/10W	RM73B--224J
R213	247 0018 905	Chip Carbon 0 ohm 1/10W	RM73B--0R0K	R380	247 0011 973	Chip Carbon 82 kohm 1/10W	RM73B--823J
R214	247 0009 985	Chip Carbon 10 kohm 1/10W	RM73B--103J	R381	247 0009 985	Chip Carbon 10 kohm 1/10W	RM73B--103J
R215	247 0005 905	Chip Carbon 100 ohm 1/10W	RM73B--101J	R382	247 0004 922	Chip Carbon 47 ohm 1/10W	RM73B--470J
R216	247 0007 945	Chip Carbon 1 kohm 1/10W	RM73B--102J	R383	247 0005 905	Chip Carbon 100 ohm 1/10W	RM73B--101J
R217	247 0009 927	Chip Carbon 5.6 kohm 1/10W	RM73B--562J	R384	247 0009 901	Chip Carbon 4.7 kohm 1/10W	RM73B--472J
R218	247 0009 956	Chip Carbon 7.5 kohm 1/10W	RM73B--752J	R386	247 0012 901	Chip Carbon 82 kohm 1/10W	RM73B--823J
R220	247 0007 945	Chip Carbon 1 kohm 1/10W	RM73B--102J	R387	247 0009 901	Chip Carbon 4.7 kohm 1/10W	RM73B--472J
R223	247 0010 974	Chip Carbon 24 kohm 1/10W	RM73B--243J	R401,402	247 0007 945	Chip Carbon 1 kohm 1/10W	RM73B--102J
R224	247 0006 988	Chip Carbon 560 ohm 1/10W	RM73B--561J	R403,404	247 0006 917	Chip Carbon 300 ohm 1/10W	RM73B--301J
R225	247 0011 944	Chip Carbon 47 kohm 1/10W	RM73B--473J	R405	247 0006 988	Chip Carbon 560 ohm 1/10W	RM73B--561J
R226	247 0012 927	Chip Carbon 100 kohm 1/10W	RM73B--104J	R406~409	247 0011 944	Chip Carbon 47 kohm 1/10W	RM73B--473J
R227	247 0009 901	Chip Carbon 4.7 kohm 1/10W	RM73B--472J	R503,504	247 0007 945	Chip Carbon 1 kohm 1/10W	RM73B--102J
R228	247 0012 927	Chip Carbon 100 kohm 1/10W	RM73B--104J	R505	247 0011 944	Chip Carbon 47 kohm 1/10W	RM73B--473J
R229	247 0006 962	Chip Carbon 470 ohm 1/10W	RM73B--471J	R506,507	247 0010 990	Chip Carbon 30 kohm 1/10W	RM73B--303J
R230	247 0014 967	Chip Carbon 1 Mohm 1/10W	RM73B--105J	R508,509	247 0011 944	Chip Carbon 47 kohm 1/10W	RM73B--473J
R231	247 0007 974	Chip Carbon 1.3 kohm 1/10W	RM73B--132J	R510	247 0005 905	Chip Carbon 100 ohm 1/10W	RM73B--101J
R232	247 0010 945	Chip Carbon 18 kohm 1/10W	RM73B--183J	R512	247 0009 985	Chip Carbon 10 kohm 1/10W	RM73B--103J
R233	247 0008 915	Chip Carbon 2 kohm 1/10W	RM73B--202J	R514~517	247 0009 985	Chip Carbon 10 kohm 1/10W	RM73B--103J
R237	247 0006 917	Chip Carbon 300 ohm 1/10W	RM73B--301J	R518	247 0009 901	Chip Carbon 4.7 kohm 1/10W	RM73B--472J
R238	247 0009 901	Chip Carbon 4.7 kohm 1/10W	RM73B--472J	R520,521	247 0009 901	Chip Carbon 4.7 kohm 1/10W	RM73B--472J
R239	247 0002 966	Chip Carbon 10 ohm 1/10W	RM73B--100J	R522~525	247 0008 928	Chip Carbon 2.2 kohm 1/10W	RM73B--222J
R247	247 0010 987	Chip Carbon 27 kohm 1/10W	RM73B--273J	R526	247 0014 967	Chip Carbon 1 Mohm 1/10W	RM73B--105J
R303	247 0009 901	Chip Carbon 4.7 kohm 1/10W	RM73B--472J	R527~533	247 0011 944	Chip Carbon 47 kohm 1/10W	RM73B--473J
R304	247 0007 945	Chip Carbon 1 kohm 1/10W	RM73B--102J	R534	247 0009 901	Chip Carbon 4.7 kohm 1/10W	RM73B--472J
R305	247 0012 927	Chip Carbon 100 kohm 1/10W	RM73B--104J	R535,536	247 0011 944	Chip Carbon 47 kohm 1/10W	RM73B--473J
R306	247 0009 985	Chip Carbon 10 kohm 1/10W	RM73B--103J	R537	247 0007 945	Chip Carbon 1 kohm 1/10W	RM73B--102J
R307	247 0007 945	Chip Carbon 1 kohm 1/10W	RM73B--102J	R542~546	247 0005 905	Chip Carbon 100 ohm 1/10W	RM73B--101J
R308	247 0012 943	Chip Carbon 120 kohm 1/10W	RM73B--124J	R548	247 0007 945	Chip Carbon 1 kohm 1/10W	RM73B--102J
R309	247 0009 985	Chip Carbon 10 kohm 1/10W	RM73B--103J	R549	247 0011 902	Chip Carbon 33 kohm 1/10W	RM73B--333J
R310	247 0010 990	Chip Carbon 30 kohm 1/10W	RM73B--303J	R550	247 0007 945	Chip Carbon 1 kohm 1/10W	RM73B--102J
R315	247 0007 945	Chip Carbon 1 kohm 1/10W	RM73B--102J	R551	247 0010 961	Chip Carbon 22 kohm 1/10W	RM73B--223J
R316	247 0008 960	Chip Carbon 3.3 kohm 1/10W	RM73B--332J	R552~554	247 0011 944	Chip Carbon 47 kohm 1/10W	RM73B--473J
R317	247 0007 945	Chip Carbon 1 kohm 1/10W	RM73B--102J	R556	247 0009 901	Chip Carbon 4.7 kohm 1/10W	RM73B--472J
R318	247 0008 960	Chip Carbon 3.3 kohm 1/10W	RM73B--332J	R558,559	247 0010 961	Chip Carbon 22 kohm 1/10W	RM73B--223J
R319	247 0009 985	Chip Carbon 10 kohm 1/10W	RM73B--103J	R560	247 0013 942	Chip Carbon 330 kohm 1/10W	RM73B--334J
R320	247 0007 945	Chip Carbon 1 kohm 1/10W	RM73B--102J	R561	247 0012 927	Chip Carbon 100 kohm 1/10W	RM73B--104J
R321	247 0008 960	Chip Carbon 3.3 kohm 1/10W	RM73B--332J	R562	247 0009 901	Chip Carbon 4.7 kohm 1/10W	RM73B--472J
R328	247 0010 903	Chip Carbon 12 kohm 1/10W	RM73B--123J	R564	247 0009 985	Chip Carbon 10 kohm 1/10W	RM73B--103J
R331	247 0011 960	Chip Carbon 56 kohm 1/10W	RM73B--563J	R600,601	247 0010 961	Chip Carbon 22 kohm 1/10W	RM73B--223J
R332	247 0012 930	Chip Carbon 110 kohm 1/10W	RM73B--114J	R602	247 0009 985	Chip Carbon 10 kohm 1/10W	RM73B--103J
R333	247 0011 944	Chip Carbon 47 kohm 1/10W	RM73B--473J	R603~605	247 0009 901	Chip Carbon 4.7 kohm 1/10W	RM73B--472J
R334	247 0012 930	Chip Carbon 110 kohm 1/10W	RM73B--114J	R606	247 0005 905	Chip Carbon 100 ohm 1/10W	RM73B--101J
R335	247 0011 957	Chip Carbon 51 kohm 1/10W	RM73B--513J	ΔR326	241 2315 912	Fusible 10 ohm 1/4W(NB)	RD14B2E100GFRS
R336	247 0012 998	Chip Carbon 200 kohm 1/10W	RM73B--204J	ΔR327	241 2313 985	Fusible 4.7 ohm 1/4W(NB)	RD14B2E4R7JFRS
R341	247 0012 927	Chip Carbon 100 kohm 1/10W	RM73B--104J	ΔR359,360	241 2377 921	Carbon Film 82 ohm 1/4W(NB)	RD14B2E820JNBS
R342	247 0011 986	Chip Carbon 88 kohm 1/10W	RM73B--683J	ΔR501,502	244 2050 904	Metal Oxide 22 ohm 1W(NB)	RS14B3A220JNBS(S)
R343	247 0011 960	Chip Carbon 56 kohm 1/10W	RM73B--563J	VR101	211 6095 907	Semi Fixed Resistor 1 kohm	V06QB102
R344	247 0012 969	Chip Carbon 150 kohm 1/10W	RM73B--154J	VR102	211 6095 952	Semi Fixed Resistor 100 kohm	V06QB104
R345	247 0011 957	Chip Carbon 51 kohm 1/10W	RM73B--513J	VR103	211 6095 910	Semi Fixed Resistor 10 kohm	V06QB103
R346	247 0011 986	Chip Carbon 68 kohm 1/10W	RM73B--683J	VR201	211 6095 907	Semi Fixed Resistor 1 kohm	V06QB102
R351	247 0010 974	Chip Carbon 24 kohm 1/10W	RM73B--243J	VR202	211 6095 952	Semi Fixed Resistor 100 kohm	V06QB104
R352	247 0011 944	Chip Carbon 47 kohm 1/10W	RM73B--473J	VR203	211 6095 910	Semi Fixed Resistor 10 kohm	V06QB103
R353	247 0010 974	Chip Carbon 24 kohm 1/10W	RM73B--243J	CAPACITORS GROUP			
R354,355	247 0012 914	Chip Carbon 91 kohm 1/10W	RM73B--913J	C101	257 0008 983	Chip Ceramic 1000 pF/50V	CK73B1H102K
R356	247 0012 969	Chip Carbon 150 kohm 1/10W	RM73B--154J	C102	257 0002 921	Chip Ceramic 10 pF/50V	CC73SL1H100D
R357	247 0012 927	Chip Carbon 100 kohm 1/10W	RM73B--104J	C103	257 0006 943	Chip Ceramic 560 pF/50V	CC73SL1H561J
R358	247 0010 974	Chip Carbon 24 kohm 1/10W	RM73B--243J				
R361	247 0009 901	Chip Carbon 4.7 kohm 1/10W	RM73B--472J				
R362	247 0007 945	Chip Carbon 1 kohm 1/10W	RM73B--102J				
R364,365	247 0009 985	Chip Carbon 10 kohm 1/10W	RM73B--103J				
R370	247 0010 961	Chip Carbon 22 kohm 1/10W	RM73B--223J				
R374	247 0009 901	Chip Carbon 4.7 kohm 1/10W	RM73B--472J				
R375	247 0009 985	Chip Carbon 10 kohm 1/10W	RM73B--103J				

Ref. No.	Part No.	Part Name	Remarks
C104	257 0004 961	Chip Ceramic 100 pF/50V	CC73SL1H101J
C105	254 4252 930	Electrolytic 100 μ F/10V	CE04W1A101M
C106	255 1256 903	Plastic Film 0.0075 μ F/50V	CQ92M1H752J(MRZ)
C107	257 0003 904	Chip Ceramic 22 pF/50V	CC73SL1H220J
C108	254 4258 905	Electrolytic 4.7 μ F/35V	CE04W1V4R7M
C109	257 0008 983	Chip Ceramic 1000 pF/50V	CK73B1H102K
C111	257 0005 986	Chip Ceramic 330 pF/50V	CC73SL1H331J
C112	257 0006 969	Chip Ceramic 680 pF/50V	CC73SL1H681J
C113	257 0005 902	Chip Ceramic 150 pF/50V	CC73SL1H151J
C114,115	254 4258 905	Electrolytic 4.7 μ F/35V	CE04W1V4R7M
C116	254 4260 935	Electrolytic 0.47 μ F/50V	CE04W1HR47M
C117,118	254 4260 948	Electrolytic 1 μ F/50V	CE04W1H010M
C120,121	257 0009 924	Chip Ceramic 2200 pF/50V	CK73B1H222K
C123	254 4278 943	Electrolytic 0.56 μ F/50V	CE04W1HR56M
C124	254 4260 922	Electrolytic 0.33 μ F/50V	CE04W1HR33M
C125~127	254 4258 905	Electrolytic 4.7 μ F/35V	CE04W1V4R7M
C128	257 0003 988	Chip Ceramic 47 pF/50V	CC73SL1H470J
C129	257 0006 927	Chip Ceramic 470 pF/50V	CC73SL1H471J
C130	257 0009 908	Chip Ceramic 1500 pF/50V	CK73B1H152K
C131	257 0012 966	Chip Ceramic 0.01 μ F/50V	CK73F1H103Z
C201	257 0008 983	Chip Ceramic 1000 pF/50V	CK73B1H102K
C202	257 0002 921	Chip Ceramic 10 pF/50V	CC73SL1H100D
C203	257 0006 943	Chip Ceramic 560 pF/50V	CC73SL1H561J
C204	257 0004 961	Chip Ceramic 100 pF/50V	CC73SL1H101J
C205	254 4252 930	Electrolytic 100 μ F/10V	CE04W1A101M
C206	255 1256 903	Plastic Film 0.0075 μ F/50V	CQ92M1H752J(MRZ)
C207	257 0003 904	Chip Ceramic 22 pF/50V	CC73SL1H220J
C208	254 4258 905	Electrolytic 4.7 μ F/35V	CE04W1V4R7M
C209	257 0008 983	Chip Ceramic 1000 pF/50V	CK73B1H102K
C211	257 0005 986	Chip Ceramic 330 pF/50V	CC73SL1H331J
C212	257 0006 969	Chip Ceramic 680 pF/50V	CC73SL1H681J
C213	257 0005 902	Chip Ceramic 150 pF/50V	CC73SL1H151J
C214,215	254 4258 905	Electrolytic 4.7 μ F/35V	CE04W1V4R7M
C216	254 4260 935	Electrolytic 0.47 μ F/50V	CE04W1HR47M
C217,218	254 4260 948	Electrolytic 1 μ F/50V	CE04W1H010M
C220,221	257 0009 924	Chip Ceramic 2200 pF/50V	CK73B1H222K
C223	254 4278 943	Electrolytic 0.56 μ F/50V	CE04W1HR56M
C224	254 4260 922	Electrolytic 0.33 μ F/50V	CE04W1HR33M
C225~227	254 4258 905	Electrolytic 4.7 μ F/35V	CE04W1V4R7M
C228	257 0003 988	Chip Ceramic 47 pF/50V	CC73SL1H470J
C229	257 0006 927	Chip Ceramic 470 pF/50V	CC73SL1H471J
C230	257 0009 908	Chip Ceramic 1500 pF/50V	CK73B1H152K
C301,302	254 4252 927	Electrolytic 47 μ F/10V	CE04W1A470M
C303	257 0014 935	Chip Ceramic 0.1 μ F/25V	CK73F1E104Z
C304	257 0008 983	Chip Ceramic 1000 pF/50V	CK73B1H102K
C305	257 0012 966	Chip Ceramic 0.01 μ F/50V	CK73F1H103Z
C306	257 0008 983	Chip Ceramic 1000 pF/50V	CK73B1H102K
C307	254 4252 943	Electrolytic 220 μ F/10V	CE04W1A221M
C308	254 4260 948	Electrolytic 1 μ F/50V	CE04W1H010M
C309	257 0009 924	Chip Ceramic 2200 pF/50V	CK73B1H222K
C310,311	254 4260 906	Electrolytic 0.1 μ F/50V	CE04W1H0R1M
C312	254 4252 930	Electrolytic 100 μ F/10V	CE04W1A101M
C313	255 1271 904	Plastic Film 0.01 μ F/200V	CQ92M2D103J
C314	257 0009 982	Chip Ceramic 6800 pF/50V	CK73B1H682K
C315	256 1034 979	Metalized 0.1 μ F/50V	CF93A1H104J
C316	254 4256 952	Electrolytic 220 μ F/25V	CE04W1E221M
C317	254 4258 918	Electrolytic 10 μ F/35V	CE04W1V100M
C318,319	254 4252 930	Electrolytic 100 μ F/10V	CE04W1A101M
C320	257 0012 966	Chip Ceramic 0.01 μ F/50V	CK73F1H103Z
C322	254 4327 904	Electrolytic 1000 μ F/6.3V	CE04W0J102M
C323,324	254 4254 909	Electrolytic 10 μ F/16V	CE04W1C100M
C326	254 4256 910	Electrolytic 22 μ F/25V	CE04W1E220M
C328	257 0004 961	Chip Ceramic 100 pF/50V	CC73SL1H101J
C329	254 4252 901	Electrolytic 22 μ F/10V	CE04W1A220M
C330	254 4260 948	Electrolytic 1 μ F/50V	CE04W1H010M

Ref. No.	Part No.	Part Name	Remarks	Ref. No.	Part No.	Part Name	Remarks
C331	257 0005 944	Chip Ceramic 220 pF/50V	CC73SL1H221J	C501,502	257 0014 935	Chip Ceramic 0.1 μ F/25V	CK73F1E104Z
C332	257 0014 935	Chip Ceramic 0.1 μ F/25V	CK73F1E104Z	C50			

CASSETTE DECK SECTION

WIRING DIAGRAM

1 2 3 4 5 6 7 8

A
B
C
D
E

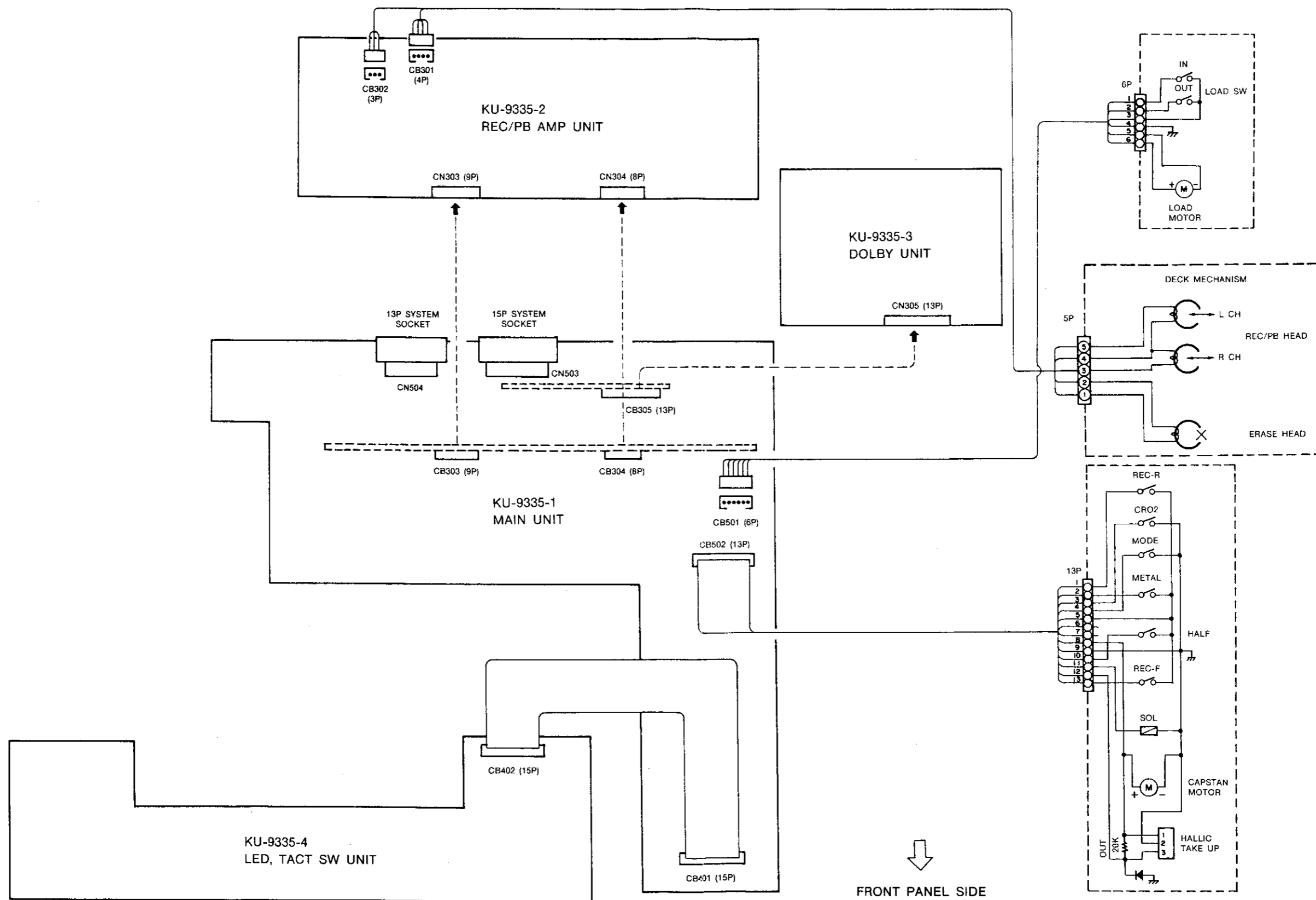

↓
FRONT PANEL SIDE

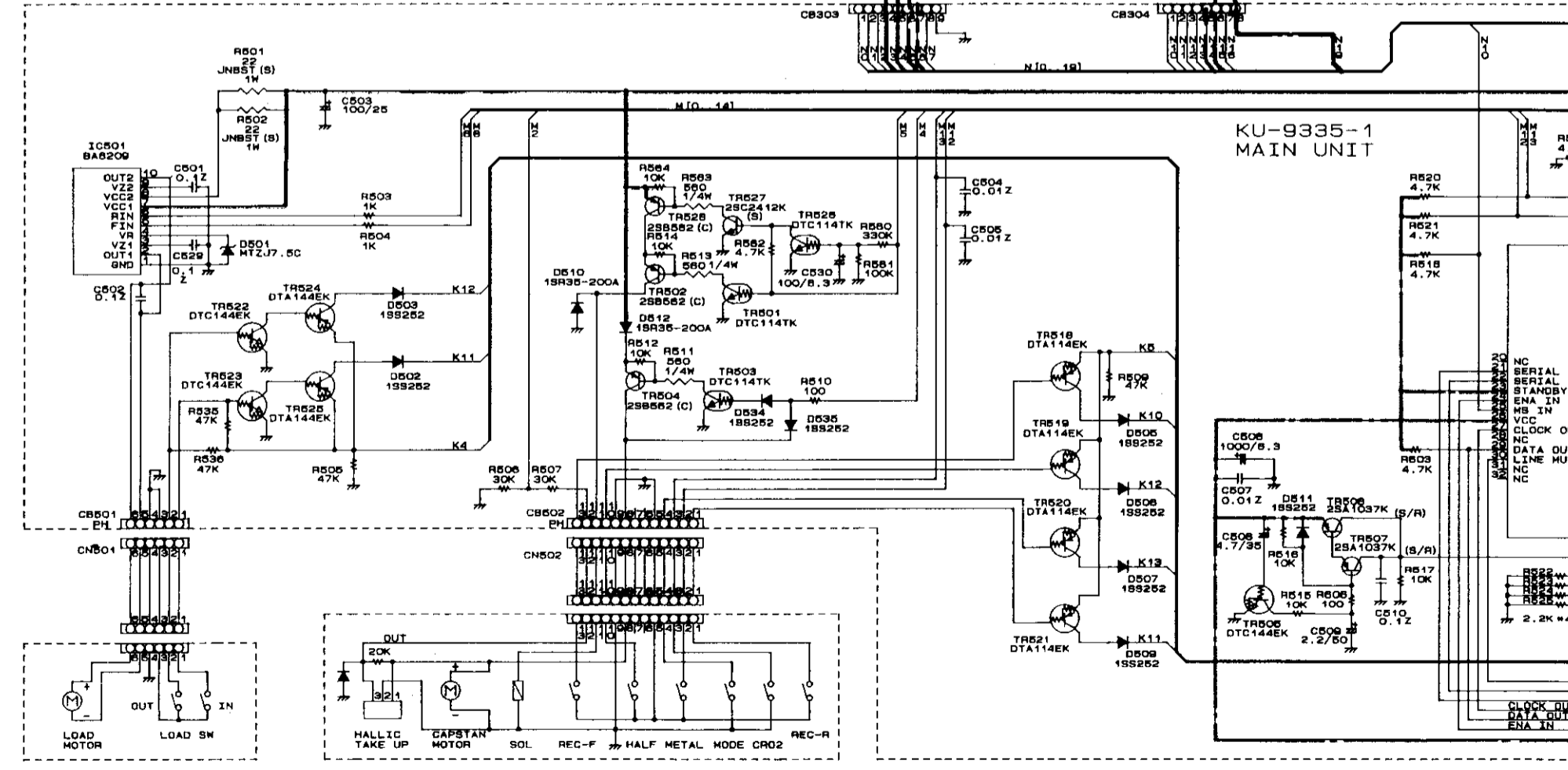
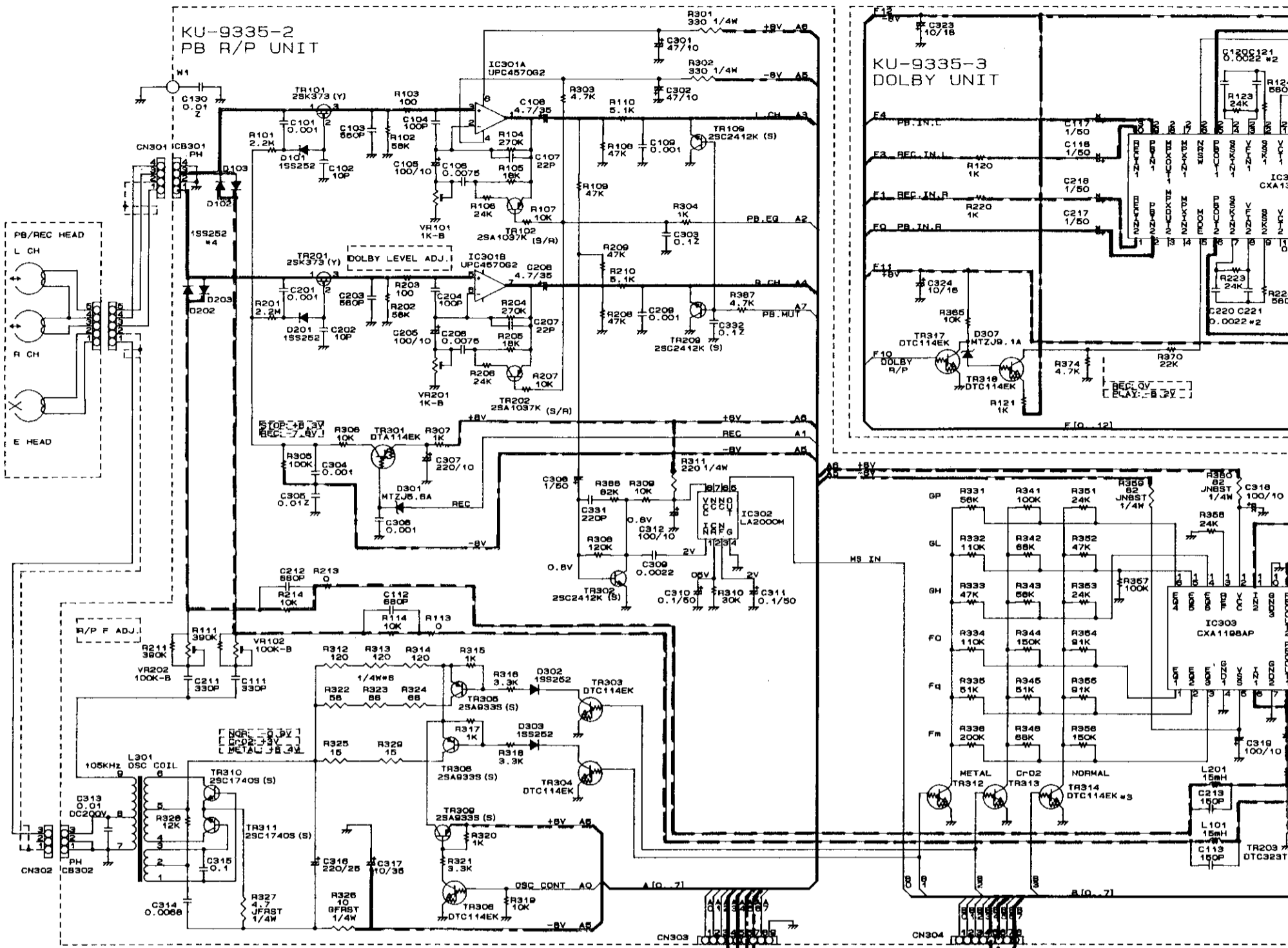

- +13.8V LINE
- - - +8V LINE
- - - -8V LINE
- +6V LINE
- PB LINE
- REC LINE

WARNING:
Parts marked with this symbol have critical characteristics. Use ONLY replacement parts recommended by the manufacturer.

CAUTION:
Before returning to service, check for leakage current. If defective, replace.
WARNING:
DO NOT REPAIR OR MODIFY.

SCHEMATIC DIAGRAM

5

6

7

8

9

10

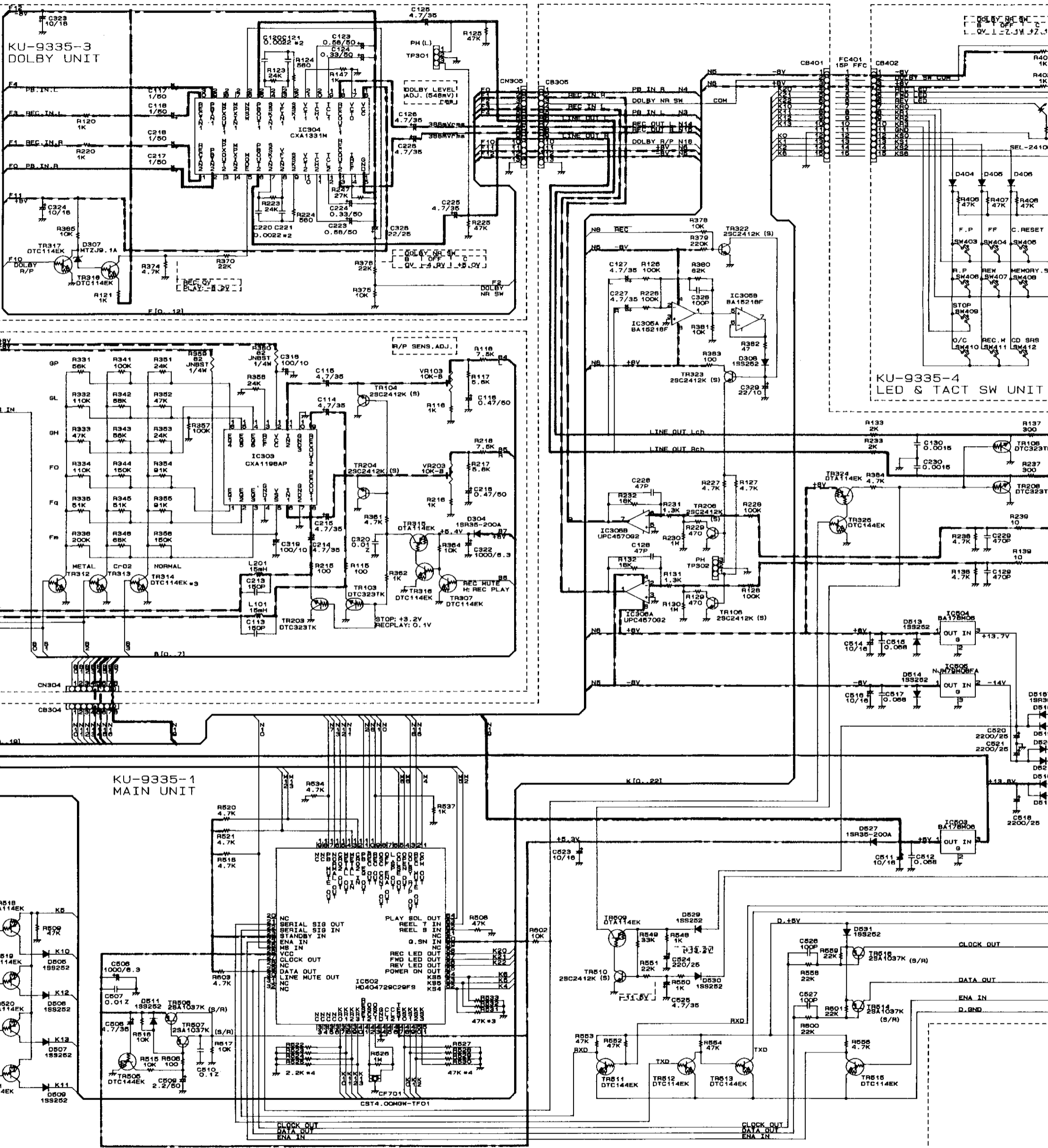

CAUTION:

Before returning the unit to the customer, make sure you make either (1) a leakage current check or (2) a line to chassis resistance check. If the leakage current exceeds 0.5 milliamps, or if the resistance from chassis to either side of the power cord is less than 240 Kohms, the unit is defective.

WARNING:

DO NOT return the unit to the customer until the problem is located and corrected.

NOTES

ALL RESISTANCE VALUES IN OHM K = ALL CAPACITANCE VALUES IN MICRO. EACH VOLTAGE AND CURRENT ARE MAXIMUM. CIRCUIT AND PARTS ARE SUBJECT TO CHANGE WITHOUT NOTICE.

with this symbol have critical characteristics. Replacement parts recommended by the manufacturer.

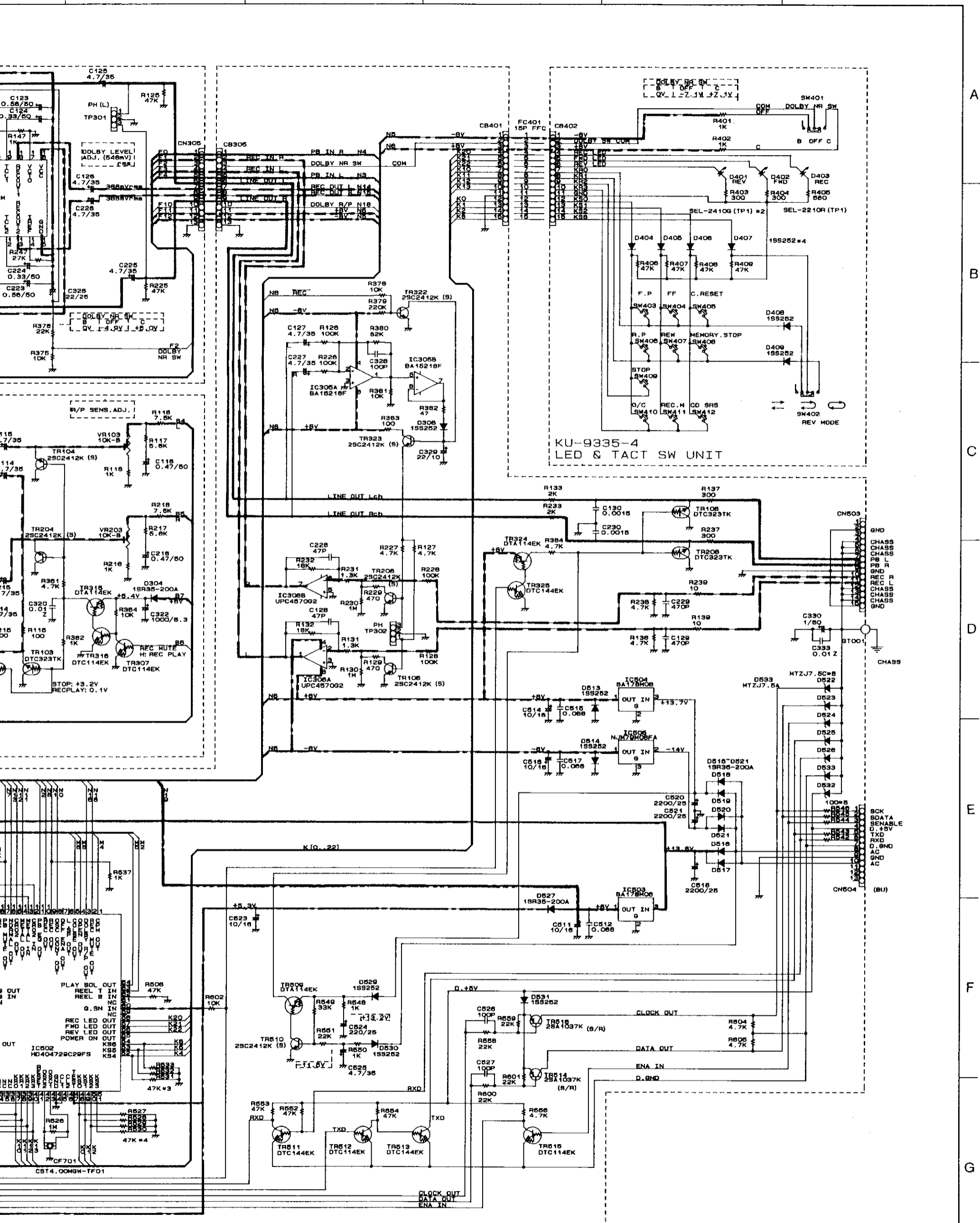

When returning the unit to the customer, make sure you make either (1) a leakage current check or (2) a line to chassis resistance check. If the leakage current exceeds 0.5 milliamperes, or if the resistance from chassis to either side of the power cord is less than 240 Kohms, the unit is not acceptable for return to the customer until the problem is located and corrected.

NOTES
 ALL RESISTANCE VALUES IN OHM K=1,000 OHM M=1,000,000 OHM
 ALL CAPACITANCE VALUES IN MICRO FARAD P=PICO-FARAD
 EACH VOLTAGE AND CURRENT ARE MEASURED AT NO SIGNAL INPUT CONDITION.
 CIRCUIT AND PARTS ARE SUBJECT TO CHANGE WITHOUT PRIOR NOTICE.

CASSETTE DECK SECTION

EXPLODED VIEW

PARTS LIST OF UDR-77 EXPLODED VIEW

Ref. No.	Part No.	Part Name	Remarks	Q'ty
1	KU- 9335	Deck Unit Ass'y		1 ^S
1-1	—	Main Unit		(1)
1-2	—	PB R/P Unit		(1)
1-3	—	Dolby Unit		(1)
1-4	—	LED & Tact SW Unit		(1)
2	212 1078 906	Slide Switch		2
3	254 4256 790	Chemicon 2200 μ F/25V	C518,520,521	3
4	205 0730 056	13 P System Socket(Bu)		1
5	204 8284 022	15 P System Socket		1
6	009 9056 007	15 P FFC		1
7	411 9115 316	Main Chassis		1
8	104 0237 308	Foot Ass'y		4
9	105 9235 126	Back Panel		1
10	449 9038 003	Mecha Holder(DR)		1
11	338 9031 001	ACLM 574A CASS/L MECH		1
12	412 2814 028	Card Spacer(L=10)		2
13	445 0048 016	Cord Holder(L=50)		1
14	412 3470 102	Spring Plate		1
15	412 3685 104	P.W.B. Bracket		1
16	146 9348 302	Inner Panel		1
17	113 9322 108	4 G Button		1
18	113 9330 006	6 G Button		1
19	113 1548 003	Select Knob		2
20	144 9236 104	Front Panel Ass'y		1
21	146 9350 109	Loader Panel(DR)		1
22	146 9346 207	Side Plate(R)		1
23	146 9347 206	Side Plate(L)		1
24	102 9043 018	Top Cover		1
★ 25	513 9390 013	Rating Sheet		1
SCREWS				
51	473 7002 018	Tapping Screw(S) 3×8		12
52	473 7015 018	Tapping Screw(S) 3×8	Black	17
53	473 7015 005	Tapping Screw(S) 3×6	Black	3
54	473 7500 044	Tapping Screw(P) 3×8	Black	2
55	473 7505 007	Tapping Screw(P) 2.6×8		7
56	473 7009 008	FH Tapping Screw(S) 3×6		2
PACKING & ACCESSORIES (Not included EXPLODED VIEW)				
71	505 0241 005	Cabinet Cover		1
72	503 9293 207	Cushion		1

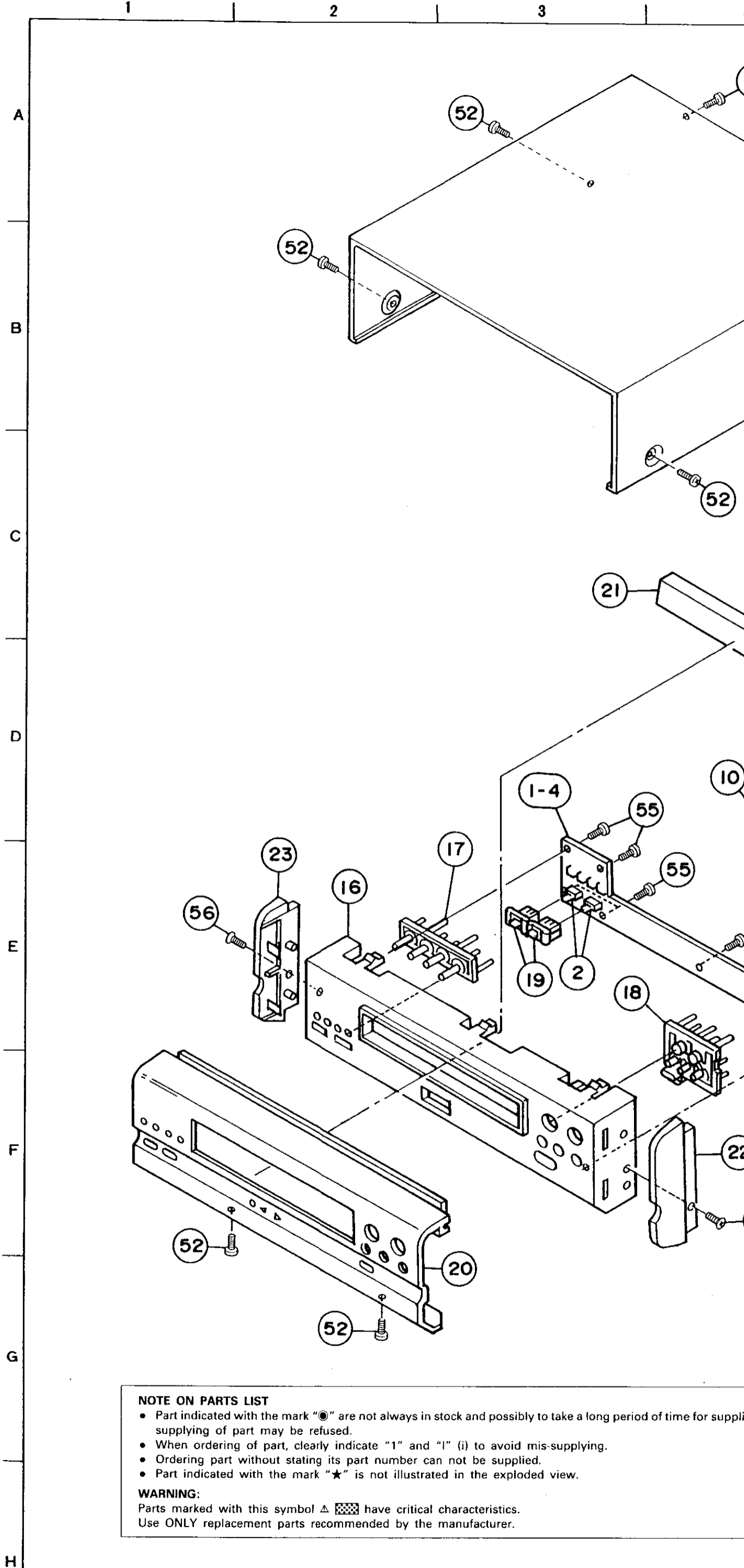

EXPLODED VIEW

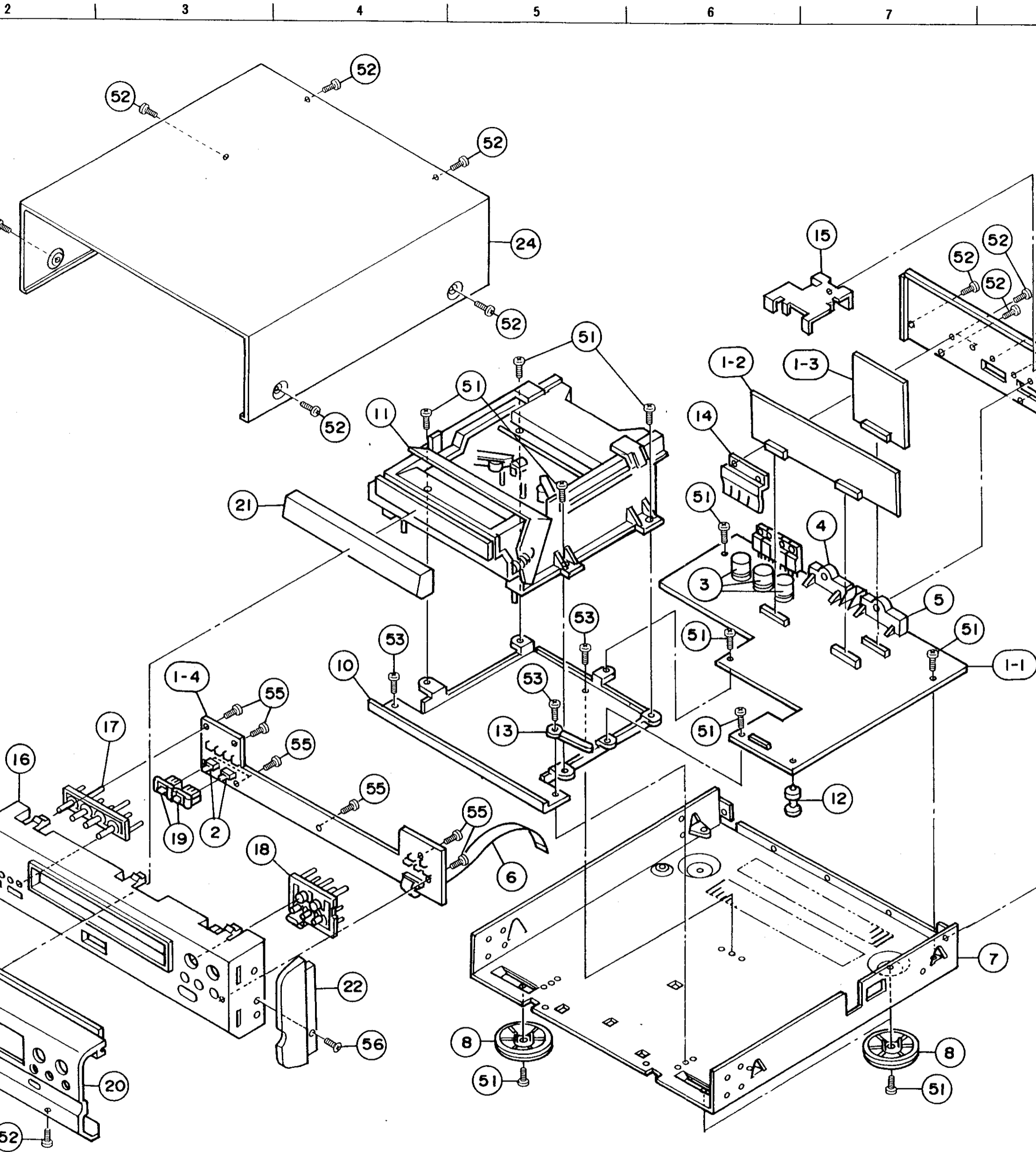

are not always in stock and possibly to take a long period of time for supplying, or in some case used.

indicate "1" and "1" (i) to avoid mis-supplying.

its part number can not be supplied.

"★" is not illustrated in the exploded view.

have critical characteristics.

recommended by the manufacturer.

52

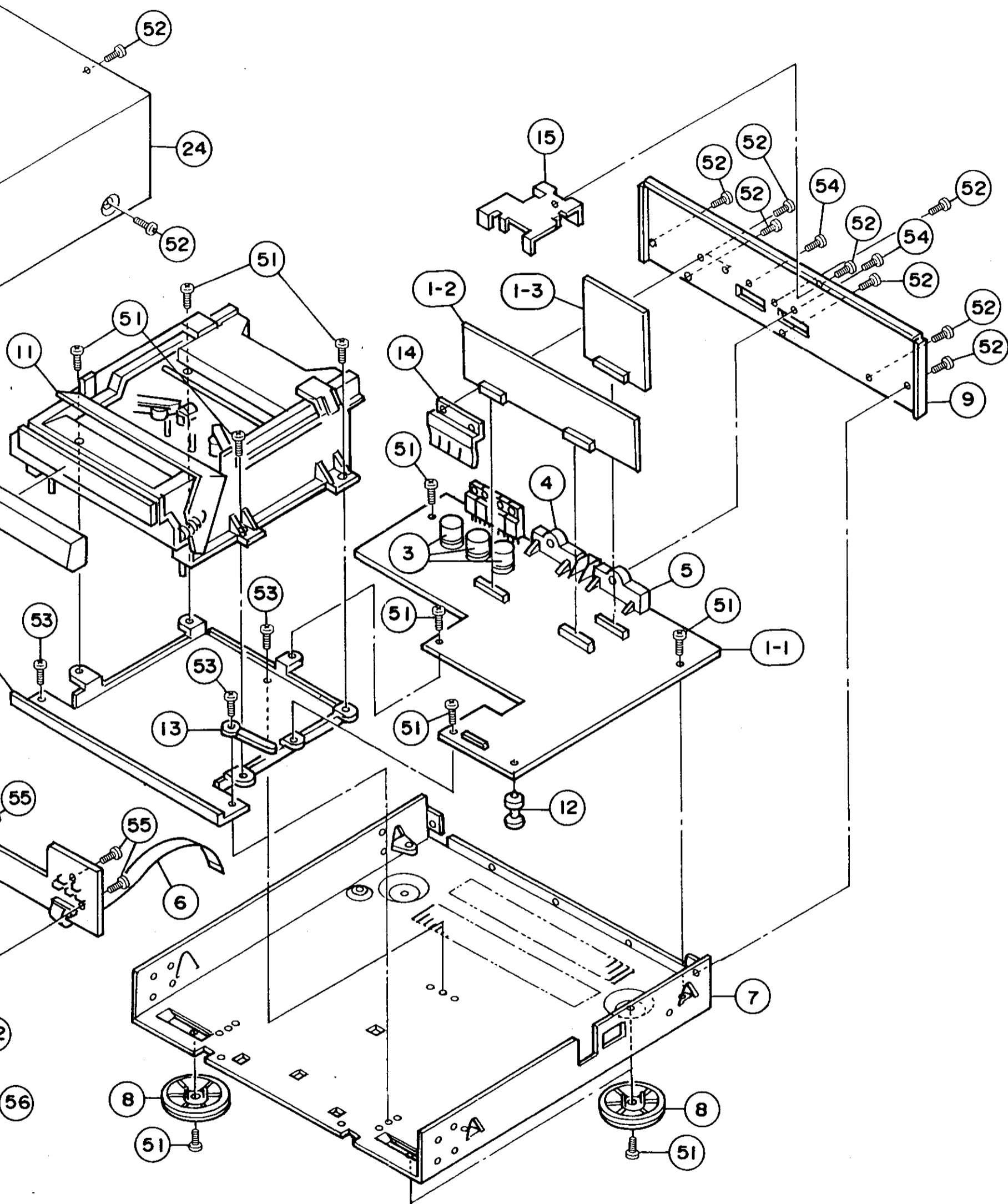

ing, or in some case

CASSETTE DECK SECTION

EXPLODED VIEW

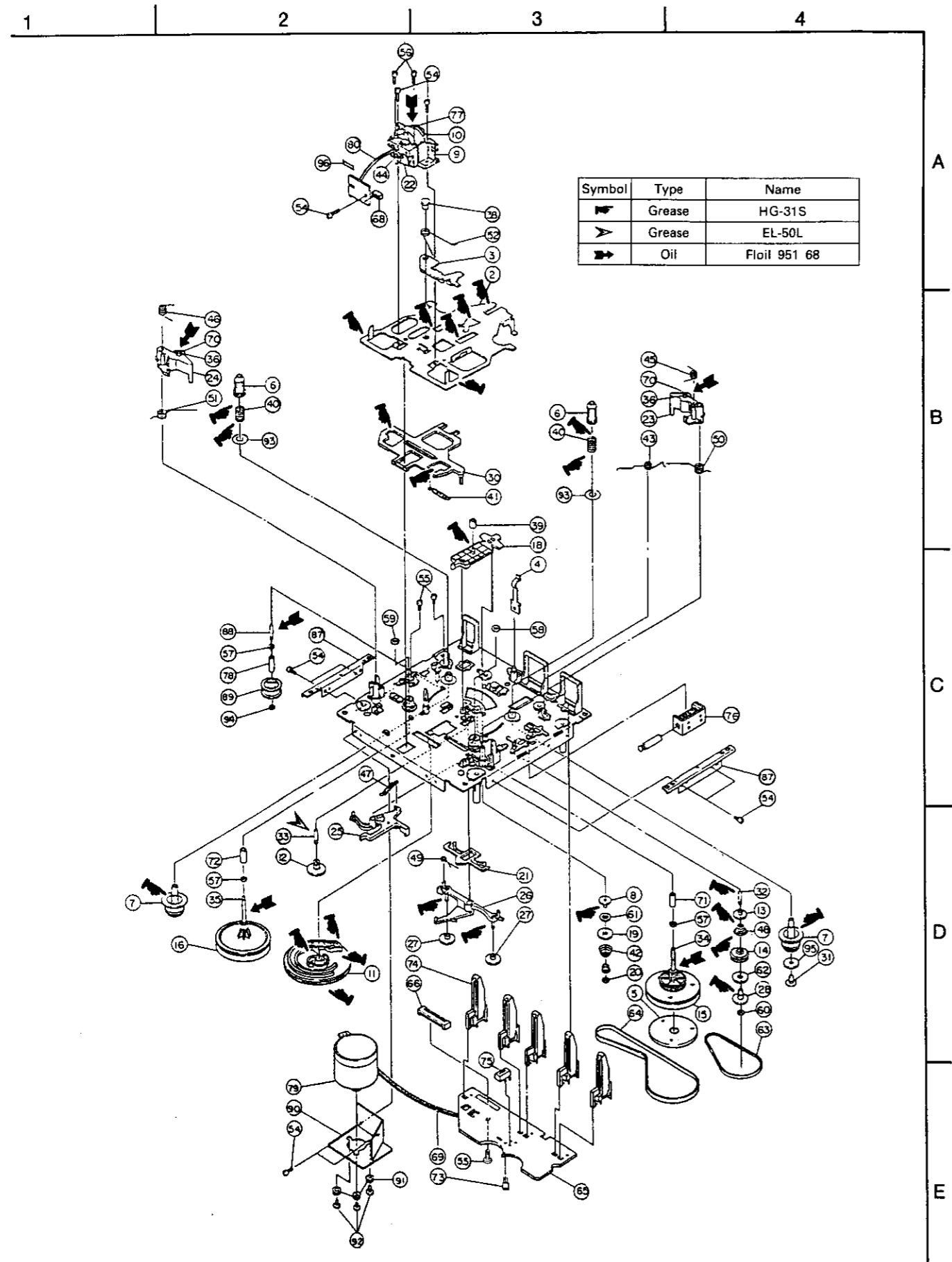

PARTS LIST OF CASSETTE MECHANISM (REC/PB)

No.	Part Name	Part Number	Description	Q'ty
1	CHASSIS MAIN	11112-00500BA		1
2	BASE HEAD	11105-00310BA		1
3	BASE SUB HEAD	11105-00420BA		1
4	PLATE SPRING	51299-12316XA		1
5	PLATE FLYWHEEL F	11143-00800BA		1
6	CHIP REEL	11110-00120AA		2
7	BASE REEL	11105-00330AA		2
8	BUSH P	11107-00220AA		1
9	BRACKET HEAD	11106-00650AA		1
10	GEAR HEAD	11128-00740AA		1
11	GEAR CAM	11128-00760AA		1
12	GEAR IDLER	11128-00780AA		1
13	BUSH C	11107-00230AA		1
14	PULLEY C	11145-00560AA		1
15	PULLEY F/W F	11145-00570AA		1
16	PULLEY F/W R	11145-00580AA		1
17	PULLEY MOTOR AD	11145-00720EB		1
18	ARM P	11102-01020AA		1
19	GEAR P	11128-00730AA		1
20	CAP P	11117-00090AA		1
21	LEVER BRAKE	11102-01030AA		1
22	GEAR DIR	11128-00750AA		1
23	ARM PINCH F	11102-01040AA		1
24	ARM PINCH R	11102-01050AA		1
25	ARM CAM LOCK	11102-01060AA		1
26	ARM RF	11102-01070AA		1
27	GEAR RF	11128-00770AA		2
28	CAP C	11117-00100AA		1
29	SPRING B/T R	51203-03098XB		1
30	LEVER AC	11134-01870AA		1
31	CAP MAGNET	11117-00120AA		1
32	SHAFT RF	11150-02260EA		1
33	SHAFT IDLER	11150-02270EA		1
34	SHAFT CAPSTAN F	11150-02291EA		1
35	SHAFT CAPSTAN R	11150-02301EA		1
36	SHAFT PINCH	11150-00130EA		2
37	PIN AZIMUTH	52017-00503XA		1
38	SHAFT BASE SUB	11150-02810EA		1
39	ROLLER P	11147-01780EA		1
40	SPRING B/T F	51203-03097XA		2
41	SPRING LEVER AC	51211-01026XA		1
42	SPRING P	51203-05106XB		1
43	SPRING BASE HEAD	51263-08046XA		1
44	SPRING DIR	51267-03036XA		1
45	SPRING PINCH F	51263-07056XA		1
46	SPRING PINCH R	51263-08056B		1
47	SPRING CAM LOCK	51211-03036XB		1
48	SPRING C	51203-06146XA		1
49	SPRING ARM RF	51264-03036XA		2
50	SPRING P/RETURN F	51263-03046XA		2

No.	Part Name	Part Number	Description	Q'ty
51	SPRING P/RETURN R	51263-03046XB		1
52	SPRING SUB	51272-10073BA		1
53	SCREW TAPPING	50032-16082EA	M1.6x8	2
54	SCREW TAPTITE	50262-20049EA	M2.0x4	4
55	SCREW EARTH	50432-20170EA		1
56	SCREW AZIMUTH	50432-20052BA		2
57	WASHER PLAIN	51000-02302BA	2.3x3.5x0.25	3
58	WASHER PLAIN	51010-01850AA	1.6x4x0.5	1
59	WASHER PLAIN	51010-01605AA	1.6x3.5x0.5	1
60	WASHER PLAIN	51010-01202AA	1.2x3.2x0.25	1
61	FELT P	11123-00312FA		1
62	FELT C	11123-00320FA		1
63	BELT SUB	51428-033AAPA	33.1x1.1x1.1	1
64	BELT M LA	51418-09905BA	99.0x3.2x0.5	1
65	PCB CONTROL 2103	11142-00270FA		1
66	CONNECTOR R/P	70219-30012LA	13P	1
67	SPRING EARTH	51201-02056XA		2
68	CONNECTOR HEAD	70219-30004EA	5P	1
69	WIRE MOTOR	70620-05002BM	2P-180	1
70	ROLLER PINCH	11147-00160FA		2
71	METAL FG F	51601-02206AA	CAPSTAN FWD	1
72	METAL FG R	51601-02020AA	CAPSTAN RVS	1
73	HALL IC	69801-99001ZA		1
74	SWITCH DETECT	70022-02055DA		5
75	SWITCH MODE	70018-04004AA		1
76	SOLENOID	79840-00009AA		1
77	HEAD R/P	71488-94044ZA	14 KHZ	1
78	METAL CYLN SUB	51601-02011AB	PULLEY SUB	1
79	MOTOR	71650-12006AA	AD2F	1
80	WIRE HEAD(BRN)	70620-01501CA	AWG36	1
81	WIRE HEAD(BLU)	70620-01501DA	AWG36	1
82	WIRE HEAD(GRN)	70620-01501GA	AWG36	1
83	WIRE HEAD(ORA)	70620-01501QA	AWG36	1
84	WIRE HEAD(RED)	70620-01501RA	AWG36	1
85	WIRE HEAD(WHT)	70620-01501WA	AWG36	1
86	WIRE HEAD(YEL)	70620-01501YA	AWG36	1
87	BRKT SIDE	11106-00970AA		2
88	SHAFT SUB	11150-02970EA		1
89	PULLEY SUB	11145-01030AC		1
90	BRKT MOTOR TOP	11106-00980AA		1
91	CUSHION MOTOR	11115-00020FA		3
92	SCREW M	50062-26041EA	MOTOR	3
93	WASHER B/T	51000-06025XA	6.0x11x0.25	2
94	WASHER PLAIN	51000-01602BA	1.6x3.2x0.25	1
95	PLATE MAGNET	11143-00970AA		1
96	WEDGE	59893-06200AB		1
97				
98				
99				

CASSETTE DECK SECTION

CASSETTE MECHANISM: ACLM-574A

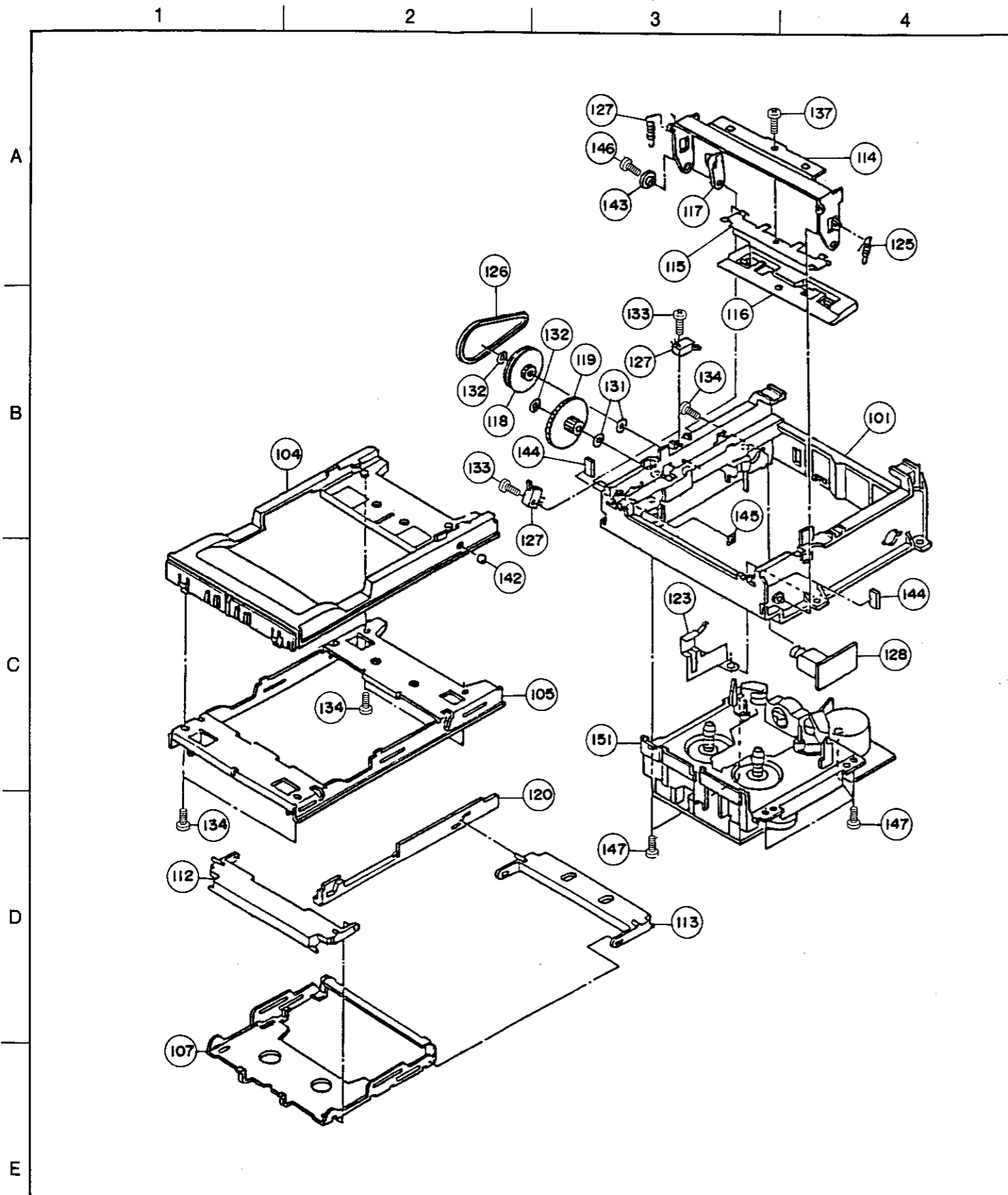

CASSETTE MECHANISM ACLM-574A PARTS LIST

No.	Parts No.	Description	Q'ty	
101	A1A001A	Flame Assy	1	
104	A1G002A	Tray	1	
105	A1P001A	Chassis	1	
107	A1A002B	Holder Assy	1	
112	A1G004A	Arm A	1	
113	A1G029A	Arm C	1	
114	A1P003A	Arm	1	
115	A1P004A	Retainer	1	
116	A1G006A	Plate	1	
117	A1G007A	Arm	1	
118	A1G008A	Pulley	1	
119	A1G009A	Gear	1	
120	A1G010A	Gear Luck	1	
123	A1P005A	Plate	1	
124	A1S001A	Spring A	1	
125	A1S002B	Spring B	1	
126	A1G011A	Beit	1	
127	S01W181	Switch MSS-8B	2	
128	A1A574A	Motor PCB Assy	1	W/6P Connector Pin
131	P21W405	PSW 2.1x4x0.5	2	
132	P21C405	PSW 2.1x4x0.5C	2	
133	N20B008	B Tite Screw M2x8BK	2	
134	N26B005	B Tite Screw M2.6x5BK	4	
135	M20N004	Screw M2x4	1	
137	S14N002	Screw M1.4x2BK	1	
142	A1H006A	Boul φ5	1	
143	A1H002A	Bush	1	
144	A1G015A	Buffer	2	
145	A1P007A	Nut	1	
146	S17N010	Screw M1.7x10BK	1	
147	M30P006	P Tite Screw 3x6BK	5	
148	A1G026A	Connector 5P-3P 4P PH	1	For Deck Head
149	A1G027A	Connector 13P-13P PH	1	For Deck
150	A1G028A	Connector 6P-6P PH	1	For Loader
151	ADR2174TB	Cassette Mechanism	1	