

DENON

Hi-Fi Personal Component System

SERVICE MANUAL PERSONAL COMPONENT SYSTEM

MODEL D-60

Europe Model

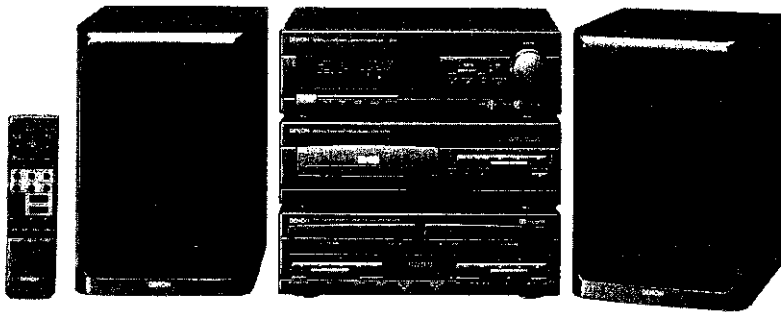

COMPACT
disc
DIGITAL AUDIO

• The D-60 Personal Component System consists of the following:

Receiver Section	UDRA-60
Remote Control Unit	RC-148
Cassette Deck Section	UDR-60
CD Section	UCD-60
Speaker Section	USC-60

MAIN FEATURES

- Full-fledged horizontal loading double cassette deck**
 - High quality deck with a performance and design above its class.
- Preset equalizer settings for selecting the desired equalization pattern**
 - Selection of equalization pattern suited for different types of music.
- SDB control**
 - The Super Dynamic Bass control circuit makes for clear bass sound.
- Editing functions**
 - Tracks on a CD can be selected automatically to fit onto sides A and B of a tape when recording.
- CD SRS function**
 - CDs can be recorded at the touch of a button.
- Three-piece separate configuration with three equal-sized units in a sleek design**
 - Freedom of layout for easy visual and operation quality.
- Easy-to-use remote control unit**
 - The simple, functionally organized remote control unit allows operation from a distance.

BEFORE USING

- Moving the system**
To prevent short-circuiting or damage of connection cords, be sure to unplug the power cord and disconnect all connection cords before moving the system.
In addition, always remove CDs before moving the system. If not, the CD may be scratched.
- Before turning the power on**
Check again that all connections are proper and that the connection cords are not damaged. Always set the power switch to the STANDBY position before disconnecting connection cords.
- Humming may be produced if the system is set near a TV set or other audio component or its connection cords. If this happens, try changing the position of the equipment and connection cords.
- Do not move the system abruptly from a cold place to a warm place, as this may cause dew (water droplets) to form in the set, preventing proper operation. If this happens, wait one hour before using the system.
- Be sure to keep this manual**
The illustrations used in this manual may differ from the actual system.

Check that the following parts are included in the package aside from the main unit:

① Operating Instructions	2
② FM Antenna	1
③ AM Loop Antenna	1
④ Remote Controller	1
⑤ R6P/AA batteries	2
⑥ Speaker Cord	2
⑦ FM Antenna adaptor	1

NIPPON COLUMBIA CO., LTD.

GENERAL SECTION-1

TABLE OF CONTENTS

General Section-1

- Main Features 1
- Before Using 1
- Specifications 3
- Operating Instructions 4~28

Receiver Section

- Disassembly Procedures 29~31
- Block Diagram 32, 33
- Adjustment 34, 35
- Semiconductors 36~40
- Microprocessor Documentation 41, 42
- Microprocessor Peripheral Wiring Diagram 43
- Wiring Diagram 44
- Schematic Diagram 45
- Exploded View, Parts List 46
- Remote Control Unit 47

Cassette Deck Section

- Disassembly Procedures 48
- Block Diagram 49
- Level Diagram 50
- Adjustment 51~53
- Semiconductors 54~57
- Microprocessor Documentation 58~60
- Microprocessor Peripheral Wiring Diagram 61
- Wiring Diagram 62
- Schematic Diagram 63
- Exploded View, Parts List 64
- Cassette Mechanism 65~70

CD Section

- Disassembly Procedures 71
- Block Diagram 72
- Laser Pickup 73, 74
- Service Points 74, 75
- Adjustment Method 76, 77
- Semiconductors 78~83
- Microprocessor Peripheral Wiring Diagram 84
- Wiring Diagram 85
- Disassembly of CD Mechanism 86
- Schematic Diagram 87
- Exploded View, Parts List 88

General Section-2

- Printed Wiring Board 89~95
- Printed Wiring Board Parts List 96~105

Speaker Section

- Schematic Diagram 106
- Exploded View, Parts List 106
- Network Ass'y 107
- Wire Forming 107

Only discs with the mark at the right can be played on this system.



Dolby noise reduction manufactured under license from Dolby Laboratories Licensing corporation. "DOLBY" and the double-D symbol (DD) are trademarks of Dolby Laboratories Licensing Corporation.

Receiver Unit	UDRA-60L
Cassette Deck Unit	UDR-60
CD Player Unit	UCD-60
Speaker System Unit	USC-60
: Top Cushion	503 1039 003
: Top Spacer	502 9126 009
: Top Spacer	502 9126 012
Space Cushion	502 9125 000
: (Master) Carton	501 9226 100
Envelope Sub Assy	GEN 2068
: Polycover	505 0178 000
: Inst. Manual	511 2361 001
: Inst. Manual	511 2361 014
Loop Antenna	231 0922 009
Remocon (RC-148)	499 0228 008
FM Ant. Assy	395 0019 025
FM Ant. Adaptor	529 0072 005

SPECIFICATIONS

■ Receiver Section (UDRA-60)

- **Power Amplifier Section**
 - Rated Output Power:** 30 W + 30 W (8 ohms 40 Hz – 20 kHz T.H.D. 0.5%)
 - Total harmonic distortion:** 0.1% at 1 kHz
- **Preamplifier Section**
 - Input sensitivity / impedance:** PHONO: 2.5 mV/47 kohms, LINE: 150 mV/10 kohms
 - Super Dynamic Bass:** ON/OFF (80 Hz + 8 dB)
 - Tone Control:** BASS: 100 Hz ± 8 dB TREBLE: 10 kHz ± 8 dB
- **FM Section**
 - Tuning frequency range:** 87.50 MHz ~ 108.00 MHz (50 kHz step)
 - Usable sensitivity:** 1.5 μV (14.8 dBf)
 - Signal to noise ratio (A-weighted):** Mono: 78 dB Stereo: 75 dB
 - Total harmonic distortion:** Mono: 0.1% Stereo: 0.3%
 - Frequency response:** 20 Hz – 15 kHz + 0.5 dB, –2 dB
 - Stereo separation:** 40 dB (1 kHz)
- **MW Section**
 - Tuning frequency range:** 522 kHz ~ 1611 kHz (9 kHz step)
 - Usable sensitivity:** 18 μV
 - Signal to noise ratio:** 52 dB
- **LW Section**
 - Tuning frequency range:** 153 kHz ~ 279 kHz (1 kHz step)
 - Usable sensitivity:** 35 μV
 - Signal to noise ratio:** 52 dB
- **Power supply:** AC 230 V, 50 Hz
- **Power consumption:** 80 W
- **Dimensions:** 270 (W) × 86.5 (H) × 248 (D) mm (10-5/8" × 3-13/32" × 9-49/64")
- **Weight:** 4 kg (8 lbs 13 oz)

■ CD Player Section (UCD-60)

- **Audio Section**
 - Sampling frequency:** 44.1 kHz
 - Frequency response:** 5 Hz ~ 20 kHz
 - Dynamic range:** 90 dB
 - Signal to noise ratio:** 90 dB
 - Total harmonic distortion:** 0.05% (1 kHz)
 - Output filter:** Digital
- **Dimensions:** 270 (W) × 86.5 (H) × 235 (D) mm (10-5/8" × 3-13/32" × 9-1/4")
- **Weight:** 1.9 kg (4 lbs 3 oz)

■ Cassette Deck Section (UDR-60)

- **Type:** Horizontal 4-track 2-channel Auto Reverse Double Cassette Deck
- **Head**
 - Record & playback:** Hard permalloy (P head & R/P head)
 - Erase:** Double gap ferrite head × 1
 - Tape speed:** 4.75 cm/S
 - Usable tapes:** Normal, chrome and metal tapes
- **Audio Section**
 - Frequency response:** 50 Hz ~ 16 kHz ± 3 dB (metal tape)
 - Signal to noise ratio:** 60 dB (Dolby B NR)
- **Dimensions:** 270 (W) × 86.5 (H) × 235 (D) mm (10-5/8" × 3-13/32" × 9-1/4")
- **Weight:** 3 kg (6 lbs 10 oz)

■ Speaker Section (USC-60)

- **Type:** 2-way Speaker System
- **Input impedance:** 8 ohms
- **Frequency response:** 50 Hz ~ 20 kHz
- **Max input power:** 50 W
- **Sound pressure level:** 89 dB (1 m • 1W)
- **Dimensions:** 172 (W) × 257 (H) × 235 (D) mm (6-25/32" × 10-1/8" × 9-1/4")
- **Weight:** 4 kg (8 lbs 13 oz)





■ Remote Control Unit (RC-148)

- **Type:** Infrared pulse
- **Number of buttons:** 26
- **Batterise:** R6P/AA type (two batteries)
- **Max. external dimensions:** 47 (W) × 173 (H) × 14 (D) mm (1-27/32" × 6-13/16" × 35/64")
- **Weight:** 100 g (approx. 3.5 oz) (including batteries)

* Maximum dimensions include controls, jacks, and covers. (W) = width, (H) = height, (D) = depth

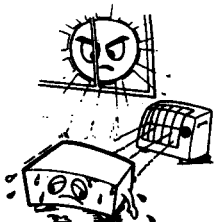
● For improvement purposes, specifications and functions are subject to change without advanced notice.

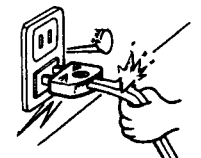
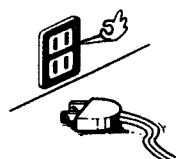
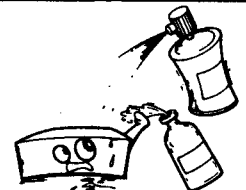
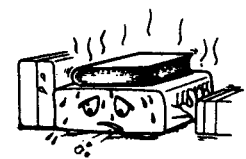
NOTE ON USE/HINWEISE ZUM GEBRAUCH/OBSERVATIONS RELATIVES A L'UTILISATION

 <ul style="list-style-type: none"> • Avoid high temperatures Allow for sufficient heat dispersion when installed on a rack. • Vermeiden Sie hohe Temperaturen Beachten Sie, daß eine zureichende Luftzirkulation gewährleistet wird, wenn das Gerät auf ein Regal gestellt wird. • Eviter des températures élevées Tenir compte d'une dispersion de chaleur suffisante lors de l'installation sur une étagère. 	 <ul style="list-style-type: none"> • Keep the set free from moisture, water, and dust. Halten Sie das Gerät von Feuchtigkeit, Wasser und Staub fern. • Protéger l'appareil contre l'humidité, l'eau et la poussière. 	 <ul style="list-style-type: none"> • Do not let foreign objects in the set. • Keine fremden Gegenstände in das Gerät kommen lassen. • Ne pas laisser des objets étrangers dans l'appareil.
 <ul style="list-style-type: none"> • Handle the power cord carefully. Hold the plug when unplugging the cord. • Gehen Sie vorsichtig mit dem Netzkabel um. Halten Sie das Kabel am Stecker, wenn Sie den Stecker herausziehen. • Manipuler le cordon d'alimentation avec précaution. Tenir la prise lors du débranchement du cordon. 	 <ul style="list-style-type: none"> • Unplug the power cord when not using the set for long periods of time. • Wenn das Gerät eine längere Zeit nicht verwendet werden soll, trennen Sie das Netzkabel vom Netzstecker. • Débrancher le cordon d'alimentation lorsque l'appareil n'est pas utilisé pendant de longues périodes. 	 <ul style="list-style-type: none"> • Do not let insecticides, benzene, and thinner come in contact with the set. • Lassen Sie das Gerät nicht mit Insektiziden, Benzin oder Verdünnungsmitteln in Berührung kommen. • Ne pas mettre en contact des insecticides, du benzène et un diluant avec l'appareil.
	 <p>*(For sets with ventilation holes)</p> <ul style="list-style-type: none"> • Do not obstruct the ventilation holes. • Die Belüftungsöffnungen dürfen nicht verdeckt werden. • Ne pas obstruer les trous d'aération. 	 <ul style="list-style-type: none"> • Never disassemble or modify the set in any way. • Versuchen Sie niemals das Gerät auseinander zu nehmen oder auf jegliche Art zu verändern. • Ne jamais démonter ou modifier l'appareil d'une manière ou d'une autre.

Irregularities

- If the system should smoke or produce strange smells, immediately set the power switch to the STANDBY position, unplug the power cord, and contact your store of purchase.

Unregelmäßigkeiten

- Sollte das Gerät Rauch produzieren oder eigenartig riechen, stellen Sie den Netzschalter sofort auf die Position STANDBY (Bereitschaft), ziehen Sie den Netzstecker heraus und kontaktieren Sie Ihren Händler.

Anomalies

- Si de la fumée sort de la chaîne ou des odeurs bizarres, placer l'interrupteur d'alimentation immédiatement sur la position de veille (STANDBY), débrancher le cordon d'alimentation et contacter le distributeur.

"SERIAL NO. _____

PLEASE RECORD UNIT SERIAL NUMBER ATTACHED TO THE REAR OF THE
CABINET FOR FUTURE REFERENCE"

FRONT PANEL/FRONT PLATTE/PANNEAU AVANT

RECEIVER
RECEIVER
RECEPTEUR

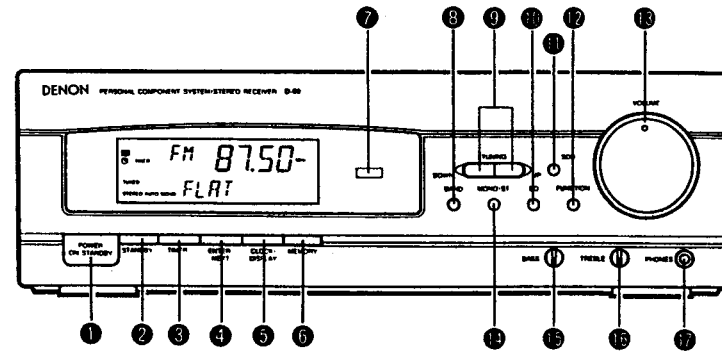

CD PLAYER
CD-SPIELER
LECTEUR CD

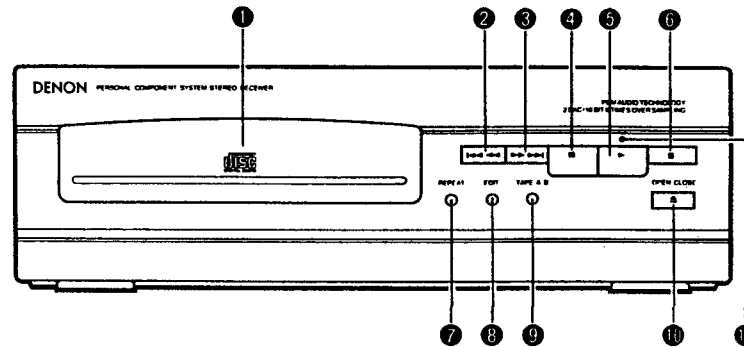

CASSETTE DECK
CASSETTENDECK
PLATINE CASSETTE

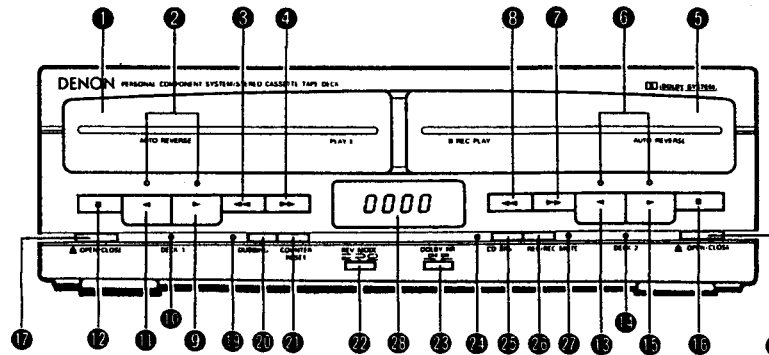

①

- * The D-60 Stereo Component System consists of the following:

Receiver Section	UDRA-60
CD Player Section	UCD-60
Cassette Deck Section	UDR-60
Speaker System Section	USC-60
Remote Control Unit	RC-148

EG-Konformitätserklärung



Die DENON Electronic GmbH
Halskestr. 32
4030 Ratingen 1

erklärt als Hersteller/Importeur, daß das in dieser Bedienungsanleitung beschriebene Gerät der Technischen Vorschrift 868/1989 nach Amtsblattverfügung im Amtsblatt des Bundesministers für Post und Telekommunikation entspricht.

Das Inverkehrbringen der vorliegenden Typenreihe ist der Prüfstelle der Bundesrepublik Deutschland (ZZF) fristgerecht angezeigt worden.

DENON-Electronic GmbH
Halskestr. 32, 4030 Ratingen 1

CLASS 1 LASER PRODUCT
LUOKAN 1 LASERLAITE
KLASS 1 LASERAPPARAT

ADVARSEL: USYNLIG LASERSTRÅLING VED ÅBNING, NÅR SIKKERHEDSAFBRYDERE ER UDE AF FUNKTION. UNGDÅ UDSÆTTELSE FOR STRÅLING.

VAROITUS! LAITTEEN KÄYTTÄMINEN MUULLA KUIN TÄSSÄ KÄYTTÖOHJEESSA MAINITULLA TAVALLA SAAJTAA ALTISTAA KÄYTTÄJÄN TURVALLISUUSLUOKAN 1 YLITÄVÄLLE NÄKYMÄTTÖMÄLLE LASERSÄTEILYLLE.

WARNING- OM APPARATEN ANVÄNDS PÅ ANNAT SÄTT ÄN I DENNA BRUKSANVISNING SPECIFICERATS, KAN ANVÄNDAREN UTSÄTTAS FÖR OSYNLIG LASERSTRÅLING SOM ÖVERSKRIDER GRÄNSEN FÖR LASERKLASS 1.

"CLASS 1
LASER PRODUCT"



- This compact disc player is capable of playing discs which have the mark at right.



CONTENTS

1	Main Features	4	9	Before Recording and Playback	17, 18
2	Before Using	4	10	Playing Cassette Tapes (Single Side Playback, Double Side Playback and Continuous Playback)	18, 19
3	Connections	5, 6	11	Convenient Functions	19
4	Part Names and Functions		12	Using the Timer	19~22
	• Receiver Section	7	13	Recording Cassette Tapes	22~24
	• CD Player Section	7	14	Unattended Recording	24
	• Cassette Deck Section	8	15	Connections to Other Components	24
	• Display Section	9, 10	16	Troubleshooting	25
5	Remote Control Unit	10, 11	17	Important Information	25
6	Setting the Current Time	11	18	Specifications	70
7	Listening to Radio Broadcasts	12, 13			
8	Playing CDs	13~16			

Check that the following parts are included in the package aside from the main unit:

①	Operating Instructions	2
②	FM Antenna	1
③	AM Loop Antenna	1
④	Remote Controller	1
⑤	R6P/AA batteries	2
⑥	Speaker Cord	2
⑦	FM Antenna adaptor	1

1 MAIN FEATURES

- Full-fledged horizontal loading double cassette deck
 - High quality deck with a performance and design above its class.
- Preset equalizer settings for selecting the desired equalization pattern
 - Selection of equalization pattern suited for different types of music.
- SDB control
 - The Super Dynamic Bass control circuit makes for clear bass sound.
- Editing functions
 - Tracks on a CD can be selected automatically to fit onto sides A and B of a tape when recording.
- CD SRS function
 - CDs can be recorded at the touch of a button.
- Three-piece separate configuration with three equal-sized units in a sleek design
 - Freedom of layout for easy visual and operation quality.
- Easy-to-use remote control unit
 - The simple, functionally organized remote control unit allows operation from a distance.

2 BEFORE USING

Note the following points before using the stereo components.

- Moving the system**
To prevent short-circuiting or damage of connection cords, be sure to unplug the power cord and disconnect all connection cords before moving the system. In addition, always remove CDs before moving the system. If not, the CD may be scratched.
- Before turning the power on**
Check again that all connections are proper and that the connection cords are not damaged. Always set the power switch to the STANDBY position before disconnecting connection cords.
- Humming may be produced if the system is set near a TV set or other audio component or its connection cords. If this happens, try changing the position of the equipment and connection cords.
- Do not move the system abruptly from a cold place to a warm place, as this may cause dew (water droplets) to form in the set, preventing proper operation. If this happens, wait one hour before using the system.
- Be sure to keep this manual.
The illustrations used in this manual may differ from the actual system.

3 CONNECTIONS

CAUTION

- Do not plug the power cord into the power outlet until all connections are completed. Connect properly as shown in the diagram.
- Check the right and left channels, and be sure to connect the speaker's L terminals to the amplifier's L terminals, the speaker's R terminals to the amplifier's R terminals.
- Be sure to insert the plugs securely. Incomplete connections can cause noise.
- This system includes digital circuitry, so it may cause problems with the colors on a TV. If so, turn the system's power switch off.

PREPARE

- 1 **Assembling the Loop Antenna**
Assemble the included AM loop antenna as shown in the diagram.

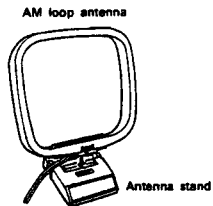

- 1 Undo the clasp.
- 2 Insert the AM loop antenna into the antenna stand.

- Note that if the input jacks selected with the FUNCTION selectors are open (if nothing is connected), the sound may leak to another component connected to different input jacks.
- Note that grouping connection cords (pin-plug cords) together with power cords or setting them near power transformers can cause noise.
- This system consists of precision components using microprocessors. Avoid using it in places where there is much external noise. The system may not operate properly if used in such places, but this is not a problem with the system. If it should function improperly, perform the desired operation once again.

- 2 **Connecting the System Connector Cord**
When connecting the system connector cord, press on the center of the connector plug until you hear a click. When disconnecting the system connector cord, press the sides of the connector plug towards the middle and pull.



NOTE

- Note that disconnecting by pulling on the cord can damage it.
- Keep the power cord unplugged when connecting the system connector cord.
- Note that connecting the system connector cord when the power cord is plugged into a power outlet may result in improper operation.

- 3 **Connecting the Included Antenna Adapter**
Connect the coaxial cable and antenna adapter using the procedure on the diagram below.

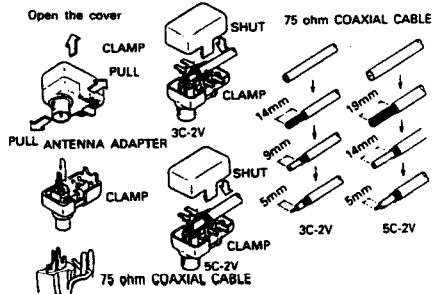

SYSTEM CONNECTIONS

Keep the FM and AM antenna wires away from the system connector wire to prevent noise from entering the antennas.

Speaker system connections
Connect the speaker system for the left channel (the left side as seen from the front) to the L terminals, the speaker system for the right channel to the R terminals. Connect the speaker systems before inserting the system connector.

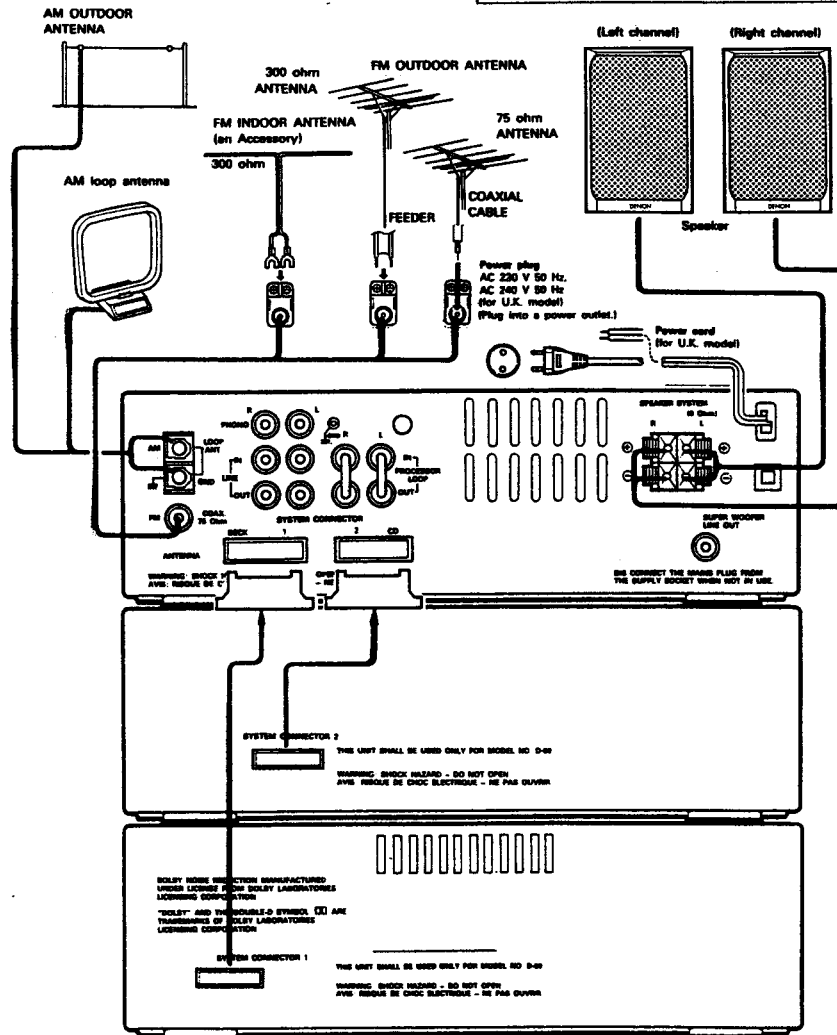

ANTENNA CONNECTIONS

Installing the AM Loop Antenna

Tune in an AM station (refer to Page 12), listen to the sound, then install the antenna in a position as far from the set as possible in which distortion and noise are minimum. In some cases it is better to connect with the polarities inverted. Good reception of AM stations is not possible if the loop antenna is not connected or if it is touching metal objects.

Connect the antenna to the FM terminals (refer to page 12), tune in an FM broadcast, then move the antenna to find a position in which distortion and noise are minimum. Secure the ends of the antenna in that position using tape, tacks, etc.

Refer to Page 5 for instructions on connecting the antenna terminal cords.

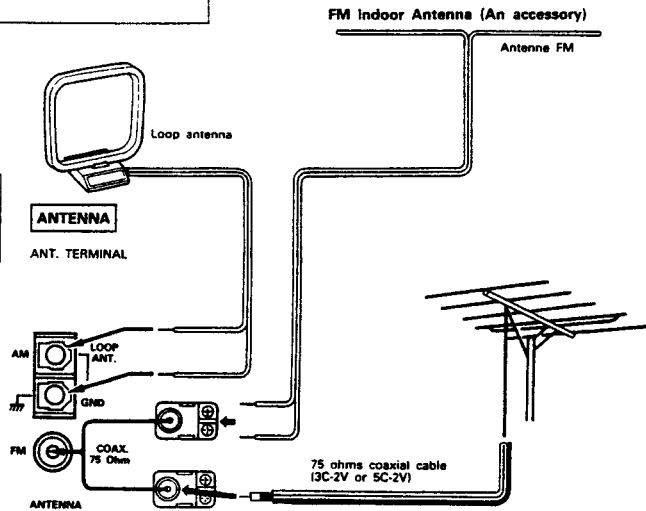

CAUTION

Use an outdoor antenna if reception is not good with the included antenna. Change the location, height, and direction of the antenna to find the position where reception is best, then fix the antenna in that position.

Places for Installing Outdoor Antennas

- Install the outdoor antenna facing a broadcast station's transmission antenna.
- When surrounded by buildings or hills, try changing the direction to obtain optimum reception.
- Do not install the antenna under power lines. It is extremely dangerous for the antenna to come into contact with a power line.
- Install away from roads or train tracks to prevent noise from cars and trains.
- Do not install the antenna too high, as it may be hit by lightning.

INSTALLING THE SETS

After completing the system connections and antenna connections, install the sets as shown on the diagrams below.

[Stacking]

CAUTION:
Set the receiver (UDRA-60) on the top.

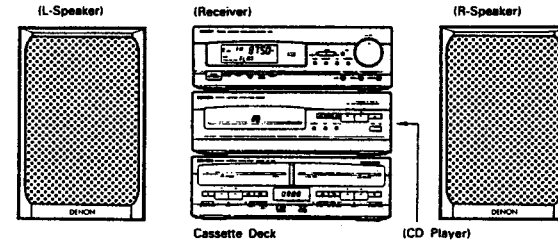

[Installing Side by Side]

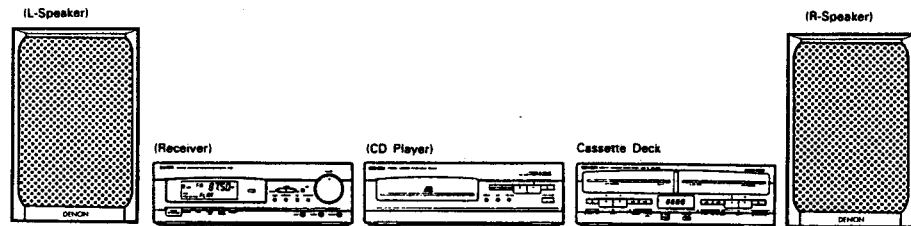

[Partial Stacking]

CAUTION:
Set the receiver (UDRA-60) on the top.

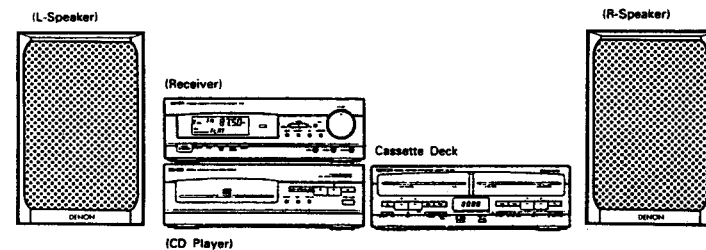

CAUTION:

- Do not plug the power cord into the power outlet until all connections are completed. Connect properly as shown in the diagram.
- This system includes digital circuitry, so it may cause problems with the colors on a TV. If so, turn the system's power switch off.

4 PART NAMES AND FUNCTIONS

RECEIVER

- 1 **POWER ON/STANDBY switch**
When pressed once, the power turns on and the display lights up. The set will begin to function normally approximately 4 to 5 seconds after the power is turned on. Press the button again to turn the power off.
- 2 **STANDBY (timer standby) button**
Press this button to turn the timer on. When pressed once, the standby indicator () appears on the display, and when pressed again, the standby indicator turns off. The timer will not function when the standby indicator is off.
- 3 **TIMER button**
This is used to set the timer.
- 4 **ENTER/NEXT button**
Use this to move on to the next step when setting the clock and timer.
- 5 **CLOCK/DISPLAY button**
Press once to display the time, once again to return to the previous display.
- 6 **MEMORY button**
Use this to store reception frequencies and modes at the preset channels.
- 7 **Remote control sensor**
This is where the signals from the remote control unit are received.
- 8 **BAND selector button**
Use this to switch between the FM, AM (MW) and AM (LW) bands. The band changes each time the button is pressed, and the currently set band is indicated on the display.
- 9 **TUNING UP and DOWN buttons**
Use these to tune in FM or AM (MW and LW) stations and when setting the clock and timer.
- 10 **PRESET EQ (equalizer) button**
Use this to switch the equalizer setting.

- 11 **SDB (Super Dynamic Bass) button**
Press this button for more powerful bass sound. Press again to turn the SDB function off.
- 12 **FUNCTION selectors**
Use these to select the program source.
- 13 **VOLUME control**
Use this control to adjust the volume. Turn clockwise () to increase the volume, counterclockwise () to decrease it.
- 14 **MONO/ST. (FM stereo mute/mono) selector button**

CAUTION:
This button will not function when receiving AM broadcasts.

(For FM reception)

STEREO: Use this mode to receive FM broadcasts in stereo. ("AUTO" appears on the display.) The muting circuit is activated to cut noise between stations.

MONO: In this mode, FM broadcasts are received in monaural, regardless of whether they are broadcast in monaural or stereo. Set to the mono mode if there is much noise in the stereo mute mode (with "AUTO" displayed) or if the signals are weak.

- 15 **BASS control**
Use this to adjust the bass.
- 16 **TREBLE control**
Use this to adjust the treble.
- 17 **PHONES jack**
When using headphones, plug them in here. The sound from the speakers is cut when headphones are plugged in. Use headphones equipped with a stereo mini-plug (3.5mm in diameter).



CD PLAYER

- 1 **Disc tray**
Load discs here.
- 2 **⏮ ⏪ (automatic/manual search reverse button)**
Press this button to move the pickup back to the beginning of the desired track. Press in the play or pause mode to move back a number of tracks equal to the number of times the button is pressed.
- 3 **⏩ ⏭ (automatic/manual search forward button)**
Press this button to move the pickup forward to the beginning of the desired track. Press in the play or pause mode to move forward a number of tracks equal to the number of times the button is pressed.
* The automatic search function is set if the button is released within 0.5 seconds, and the manual search function is set if the button is held in for more than 0.5 seconds.
- 4 **⏸ PAUSE button**
Press this button to stop playback temporarily. Press the PLAY button to resume playback.
- 5 **▶ PLAY button**
Press this button to start playing the disc. If pressed when the disc holder is open, the disc holder closes and playback begins.
- 6 **■ STOP button**
Press this button to stop playback.
- 7 **REPEAT button**
Press this button for repeat playback.
- 8 **EDIT button**
Press this button for edited recording (dividing the tracks to be recorded to fit onto sides A and B of a tape according to the tape's length).
- 9 **TAPE A/B button**
Press this button during editing to switch the display between the display for side A and the display for side B of the tape.
- 10 **⏏ OPEN/CLOSE button**
Press this to open and close the disc holder. The disc holder opens out when the button is pressed once, and closes when the button is pressed again. If a disc is loaded, the total number of tracks and total time of that disc appears on the display several seconds after the disc holder is closed.
- 11 **Disc play indicator**
This lights when a disc is playing, and flashes when in the pause mode.

CASSETTE DECK

- 1 Cassette tray: Deck 1**
The cassette tray opens out when the OPEN/CLOSE button ● is pressed. Insert the cassette tape with the side on which the tape is exposed facing away from you. To close the cassette tray, press the OPEN/CLOSE button ● again.
- 2 Tape direction indicators: Deck 1**
These indicate the direction of playback of the tape in Deck 1 as well as whether or not a tape is loaded. The indicators flash when the tape is being fast-forwarded or rewound. The tape direction indicators for Deck 2 remain off when the tape in Deck 1 is moving.
- 3 ◀ (rewind) button: Deck 1**
Press this to rewind the tape in Deck 1. Also, if pressed during playback in the ▶ (forward) direction, the tape is rewound to the beginning of the currently playing selection, and if pressed during playback in the ◀ (reverse) direction, the tape is forwarded to the beginning of the next selection (on the back side of the tape).
- 4 ▶▶ (fast-forward) button: Deck 1**
Press this to fast-forward the tape in Deck 1. Also, if pressed during playback in the ▶ (forward) direction, the tape is fast-forwarded to the beginning of the following selection, and if pressed during playback in the ◀ (reverse) direction, the tape is rewound to the beginning of the currently playing selection (on the back side of the tape).
- 5 Cassette tray: Deck 2**
When the OPEN/CLOSE button is pressed, the cassette tray opens out. Place the cassette tape in the tray with the side on which the tape is exposed facing the back. To close the cassette tray, press the OPEN/CLOSE button again.
- 6 Tape direction indicators: Deck 2**
These indicate the direction of playback of the tape in Deck 2 as well as whether or not a tape is loaded. The indicators flash when the tape is being fast-forwarded or rewound. The tape direction indicators for Deck 1 remain off when the tape in Deck 2 is moving.
- 7 ▶▶ (fast-forward) button: Deck 2**
Press this to fast-forward the tape in Deck 2. Also, if pressed during playback in the ▶ (forward) direction, the tape is fast-forwarded to the beginning of the following selection, and if pressed during playback in the ◀ (reverse) direction, the tape is rewound to the beginning of the currently playing selection (on the back side of the tape).
- 8 ◀◀ (rewind) button: Deck 2**
Press this to rewind the tape in Deck 2. Also, if pressed during playback in the ▶ (forward) direction, the tape is rewound to the beginning of the currently playing selection, and if pressed during playback in the ◀ (reverse) direction, the tape is forwarded to the beginning of the next selection (on the back side of the tape).
- 9 ▶ (forward play) button: Deck 1**
Press this button to begin playback in the forward direction on Deck 1.
- 10 Deck 1 indicator**
This indicator lights when Deck 1 is selected. This indicates the deck for which the counter is functioning. Normally, the indicator on the deck which has been operated lights.
- 11 ◀ (reverse play) button: Deck 1**
Press this button to begin playback in the reverse direction on Deck 1.
- 12 ■ (stop) button: Deck 1**
Press this button when the tape in Deck 1 is moving to stop the tape.
- 13 ◀ (reverse play) button: Deck 2**
Press this button to begin playback in the reverse direction on Deck 2.
- 14 Deck 2 indicator**
This indicator lights when Deck 2 is selected. This indicates the deck for which the counter is functioning. Normally, the indicator on the deck which has been operated lights.
- 15 ▶ (forward play) button: Deck 2**
Press this button to begin playback in the forward direction on Deck 2.
- 16 ■ (stop) button: Deck 2**
Press this button when the tape in Deck 2 is moving to stop the tape.

The tape direction indicators for Decks 1 and 2 (● and ●) also indicate whether or not cassette tapes are loaded. The indicators remain off if no cassette tape is loaded when in the stop mode.

- 17 ▲ OPEN/CLOSE button: Deck 1**
Press this button to open and close the cassette tray.
- 18 ▲ OPEN/CLOSE button: Deck 2**
Press this button to open and close the cassette tray.
- 19 Dubbing indicator**
This lights during dubbing.
- 20 DUBBING button**
Dubbing (copying) a tape from Deck 1 onto Deck 2 is possible simply by pressing this button.
- 21 COUNTER RESET button**
Press this button to reset the tape counter to '0000'.
- 22 REV. MODE switch**
Use this to set the reverse mode to one of the following modes:  (Single side mode),  (Double side [reverse] mode),  (continuous mode). Refer to Page 18.
- 23 DOLBY NR selector switch**
Use this switch to select the Dolby NR mode, ON, OFF. During playback, set this switch to the same mode in which the tape was recorded.
- 24 CD SRS indicator**
This lights during recording with the CD SRS function.

- 25 CD SRS (CD synchronized recording button)**
Use this button for CD synchronized recording. Refer to Page 22.

CD SRS button

This button is used for recording CDs (Page 22). Pay attention to the following:

- ① Recording begins on the tape as soon as this button is pressed, so be sure to wind up the leader tape beforehand.
- ② If this button is pressed while a CD is playing, the CD SRS indicator (●) lights but recording onto the tape does not begin. Stop the CD first before pressing this button.

- 26 REC/REC MUTE (recording/recording mute) button**
To record, press the REC/REC MUTE button, then press the ▶ or ◀ button.
If only the REC/REC MUTE button is pressed, the deck is set to the recording pause mode. If this button is pressed during recording, the recording mute mode is set for approximately 5 seconds, after which the deck is set to the recording pause mode. To resume recording, press the ▶ or ◀ button.

When the **REC/REC MUTE** button is pressed while the cassette deck is in the stop mode, a blank section of approximately 5 seconds is created on the tape, after which the deck is set to the recording pause mode. If the REC/REC MUTE button is held in, a blank section is created on the tape until the point where the button is released.

Recording pause mode

Recording of the CD begins if the CD player's PLAY key is pressed during the recording pause mode.

- 27 REC/REC MUTE indicator**
This lights when the recording or recording standby mode is set using the REC/REC MUTE button ●, and flashes during the recording mute mode.
- 28 Tape counter**
The tape counter functions for the deck whose indicator (● or ●) is lit.

NOTE

- After the power cord is plugged into an outlet, a mechanical sound is produced from the cassette deck when the power switch is turned on the first time only. This is the sound of the cassette mechanism being set to the proper operating position, and is not a problem with the deck.

RECEIVER DISPLAY

On this system, the receiver includes a multi-display. This display indicates various types of information for different modes depending on which section of the system is being used, as follows:

- When listening to the radio or when using the timer See diagram below.
- When listening to a CD Refer to Page 9.
- When listening to a tape Refer to Page 10.

This lights to indicate that the timer is set.

This lights when signals are received from the remote control unit.

This indicates the band being received (AM (MW and LW) or FM) and the preset number when presetting stations in the memory.

The reception frequency, function, time, and timer settings are displayed here.

NOTE:
 • The timer standby mark "⊖" will not light if the current time is not set.

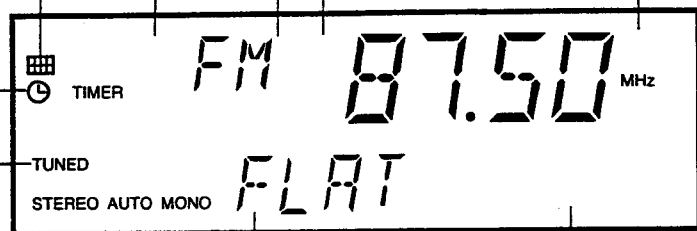

This lights when the station is tuned in properly.

When presetting stations in the memory : "MEMORY"
 When setting the timer times : "ON" or "OFF"
 When recalling a preset station : Preset number
 When the sleep timer is operating : "SLEEP"
 When an equalizer setting is selected : Equalizer mode
 During muting : "MUTING"
 * Normally the equalizer setting is displayed.

CD PLAYER DISPLAY

Tape type and remaining time display
 During the editing function, C-DD lights and the tape time is displayed.

These indicate the time display mode.
 TOTAL lights when the remaining time for all tracks is displayed.
 SINGLE lights when the remaining time per track is displayed.

Track number display
 DD is displayed when the disc data cannot be read properly.
 When a disc is loaded:
 • The total number of tracks is displayed in the stop mode.
 • The track number is displayed in the play and program modes.
 • [C or] is displayed when the innermost or outermost section of the disc is reached in the manual search mode.

Time display
 DDD is displayed when the disc data cannot be read properly.
 When a disc is loaded:
 • The elapsed playing time is displayed in the stop mode.
 • The elapsed time for the track currently playing is displayed in the play and pause modes.
 • The elapsed time for the programmed tracks is displayed in the program mode.

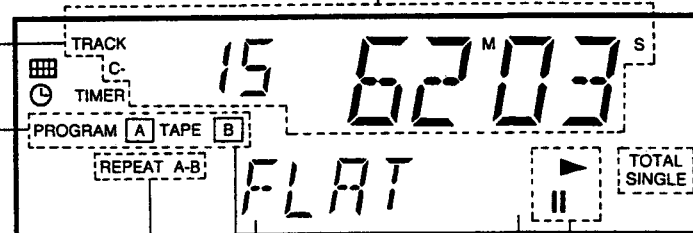

PROGRAM lights during the programmed search mode.

▶ PLAY lights when the disc is playing, and || PAUSE lights when in the pause mode.

The indicators switch as follows when the REPEAT button is pressed in the play mode:

- First press : REPEAT TRACK
- Second press : REPEAT ALL
- Third press : REPEAT [A]
- Fourth press : REPEAT [A]-[B]
- Fifth press : None Display

During editing operations: "REMAIN"
 During edited recording: "EDIT"
 When no disc is loaded, when the disc is loaded upside-down, or when the disc is heavily scratched or dirty : "NO DISC"

During the editing operation, "EDIT [A] TAPE" is displayed and the remaining time for side A of the tape is indicated on the time section of the display. When the TAPE SIDE A/B button is pressed, "[A]" turns off, "[B]" turns on, and the remaining time for side A of the tape is indicated in the same way. The ▶ PLAY indicator lights when a disc is playing, and the || PAUSE indicator lights when the pause mode is set.

CASSETTE DECK DISPLAY

RECEIVER SECTION

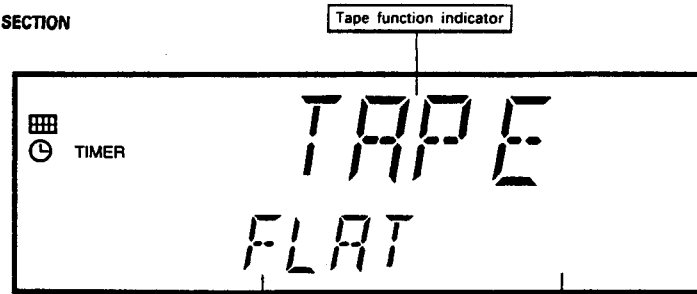

When an equalizer setting is selected: Equalizer mode
 When the sleep timer is operating: "SLEEP"
 During muting: "MUTING"
 * Normally the equalizer setting is displayed.

CASSETTE DECK SECTION

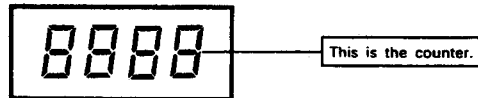

Remaining Tape Indicators

These indicators notify that the tape is reaching the end during recording and playback. The indicators differ according to the diameter of the tape hub.

This starts flashing when the tape is nearing the end during recording or playback, then stops flashing and remains lit once the end of the tape is reached.

* The approximate remaining time on the tape after the different sections of the tape counter start flashing one by one is as follows:

Hub diameter \ Tape length	Normal hub		Large hub	
	Playback in forward direction	Playback in reverse direction	Playback in forward direction	Playback in reverse direction
C-46	Approx. 5 minutes	Approx. 5 minutes	Approx. 1 minutes	Approx. 1 minutes
C-60	Approx. 5 minutes	Approx. 5 minutes	Approx. 1 minutes	Approx. 1 minutes
C-90	Approx. 6 minutes	Approx. 5 minutes	-	-

* There are no C-90 tapes with large hubs.

* Large hubs are hubs with a diameter of about 27mm. Note that if the hub is larger than this, there may be a major error in indicating the remaining time.

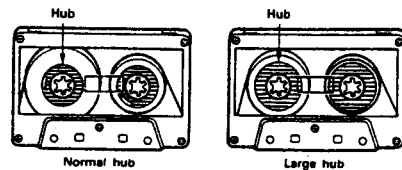

NOTE

The remaining tape times shown on the table at the right are only rough estimates. In addition, the tape end indication may not work when using cassettes with thick tapes or cassettes on which the diameter of the wound tape is large.

Dolby noise reduction manufactured under license from Dolby Laboratories Licensing Corporation. "DOLBY", the double-D symbol  is trademarks of Dolby Laboratories Licensing Corporation.

5 REMOTE CONTROL UNIT

The D-60 comes with a remote control unit (RC-148) for system control.

Cautions on Use

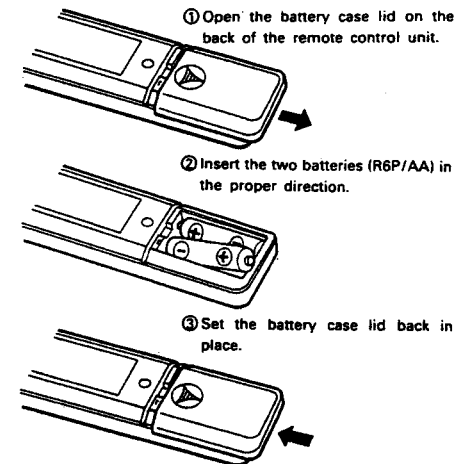

- Use R6P/AA batteries in the remote control unit.
- Replace the batteries with new ones after approximately one year of use, though this time depends on the frequency with which the remote control unit is operated.
- If the remote control unit does not function when operated from close to the main unit, replace the batteries with new ones, even if the previous batteries have been used for less than a year.
- Insert the new batteries in the proper "+" and "-" directions, following the marks on the remote control unit's battery compartment.
- To make the batteries last longer, remove them when not using the remote control unit for long periods of time.
- To prevent damage or leakage of battery fluid:
 - Do not use an old battery together with a new one.
 - Do not use two batteries of different types together.
 - Do not short-circuit, take apart, heat, or dispose of batteries in flames.
- If the battery fluid should leak, carefully wipe all the battery fluid off the inside of the battery compartment, then insert new batteries.

Inserting the Batteries



Remote Control Unit

CAUTIONS:

- The remote control unit may not function properly if the infrared sensor (remote control sensor) is exposed to direct sunlight or other strong light, or if there is an obstacle between the remote control unit and the remote control sensor.
- When adjusting the volume from the remote control unit, the volume will stop changing if the remote control transmitter is moved away from the remote control sensor. Press the button again to continue changing the volume.
- The "signal received" mark  does not light when the EQ key on the remote control unit is pressed.
- If  appears on the tuner's display due to incidental light even though the remote control unit has not been operated, it is best to move the set or place it in a different direction. However, this will not cause malfunction.
- Do not press buttons on the remote control unit and on the main unit at the same time. This will lead to malfunction.
- When the [MUTE] button on the remote control unit is pressed, the sound is muted and remains muted when the power switch is turned off then turned back on. In such cases, press the [MUTE] button on the remote control unit again.

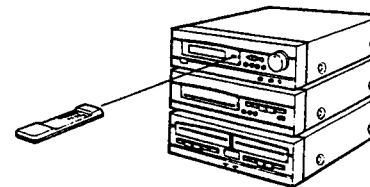

The remote control sensor is located on the right side of the display window on the receiver. Point the remote control unit at the sensor when using it, as shown in the diagram. The remote control unit will function from a maximum direct distance of approximately 7 meters. This distance will decrease, however, if there is an obstacle between the remote control unit and the sensor, or if used the remote control unit is used from an angle.

The "signal received" mark lights in the bottom corner of the receiver's display when signals are received from the remote control unit.

Part Names and Functions

POWER button

Press this to turn the power for the entire system on and off.

Operating the Cassette Decks

OPEN/CLOSE (▲)
Press this to open and close the cassette trays.

DECK 1/2
Press this to select the deck to be operated.

Stop button (■)
Press this to stop the tape.

Forward play button (▶)
Press this to play or record in the forward direction.

Reverse play button (◀)
Press this to play or record in the reverse direction.

REC/REC MUTE (recording mute button) (●)
To set to the recording mode when in the stop mode, press this button, then press either the "▶" or "◀" button. When pressed during the recording or recording pause mode, a blank section of approximately 5 seconds is created on the tape, after which the deck is set to the recording pause mode.

Rewind button (◀◀)
Press this to rewind the tape.

Fast-forward button (▶▶)
Press this to fast-forward the tape.

All operations marked [R] from the following page on are possible using the remote control unit.

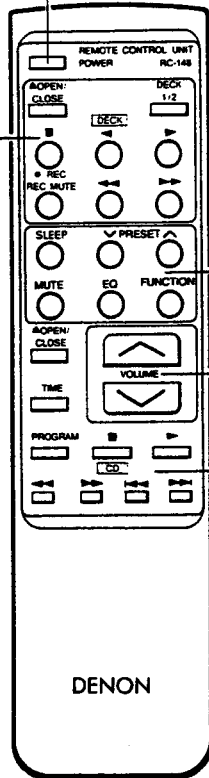

Operating the Receiver

SLEEP
Press this to set the sleep timer.

PRESET
Press these to tune in preset stations.

MUTE
When pressed once, the sound is muted, and when pressed again, the volume returns to the previous setting.

EQ
Press this to select an equalizer setting suitable for the type of music you are currently listening to.

FUNCTION (function selector)
Press this to switch the function between TUNER, TAPE, CD, PHONO and LINE.

VOLUME
Use these to adjust the volume. The volume decreases when the V button is pressed, and increases when the A button is pressed.

Operating the CD Player

OPEN/CLOSE (▲)
Press this to open and close the disc tray.

TIME
The time on the display switches as follows each time this button is pressed: Remaining time per track → Total remaining time → Elapsed time per track.

PROGRAM
Use this for programming tracks.

Stop button (■)
Press this to stop playback.

Play button (▶)
Press this to start playback.

Manual search reverse button (◀◀)
Manual search forward button (▶▶)
Use these to forward or reverse the CD.

Auto search reverse button (◀◀)
Auto search forward button (▶▶)
Use these to search for the beginning of the desired track.

NOTE:
If the open/close button on the remote control unit is pressed and the disc tray is opened or closed when no disc is loaded, the remote control operation is given priority, and nothing will happen when the play button or other buttons on the main unit are pressed. If this happens, press the open/close button on the main unit before using it.

6 SETTING THE CURRENT TIME

Setting the Current Time (The time is displayed in the 24-hour mode)

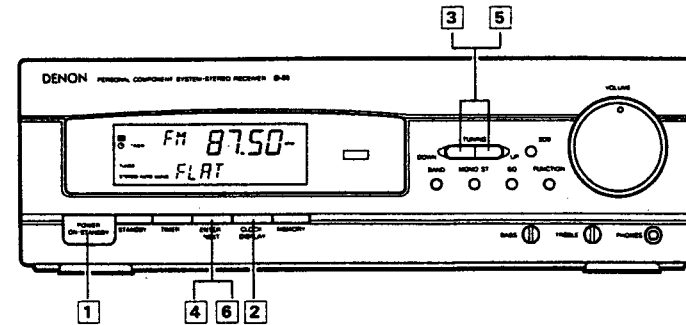

Example: Setting the time to 7:30 (The time is displayed in the 24-hour mode.)

1	Press the POWER ON/STANDBY button to turn the power on.		
2	Press the CLOCK/DISPLAY button, and hold it in for at least 3 seconds.		0:00
3	Use the UP and DOWN buttons to set the hours.		7:00
4	Press the ENTER/NEXT button.		7:00
5	Use the UP and DOWN buttons to set the minutes.		7:30
6	Press the ENTER/NEXT button at the sound of a time service's chime. The time display stops flashing, and the clock starts counting the time.		7:30

7 LISTENING TO RADIO BROADCASTS

TUNING

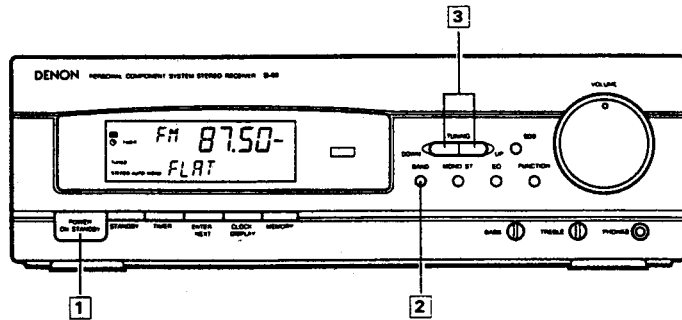

Presetting AM and FM stations

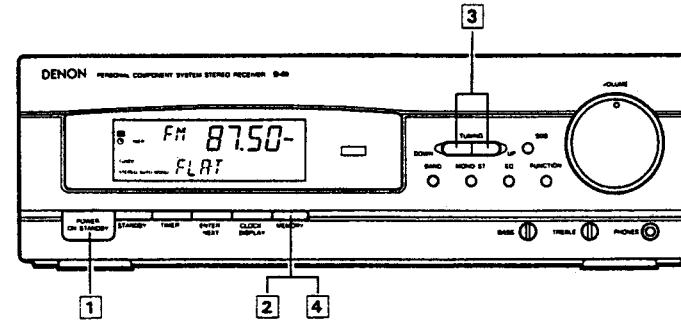

(Example: Tuning to FM 102.50 MHz)

1	Set the VOLUME control to the "MIN" position, then press the POWER ON/STANDBY button to turn the power on.		
2	Select the FM band with the BAND button.		
3	Use the UP and DOWN buttons to tune to 102.50 MHz.		

FM stereo reception

- Press the MONO/ST button to turn the "AUTO MONO" indicator on. When an FM stereo broadcast is received, the "STEREO" indicator lights and the broadcast is received in stereo.
- When the MONO/ST button is pressed and the "MONO" indicator is turned on, the "STEREO" indicator turns off and the broadcast is received in monaural.

Note:

Use the same operation to receive AM (MW or LW) stations.

Example: Presetting FM 102.50 MHz (currently tuned in) to preset button 3

1	Set the VOLUME control to the "MIN" position, then press the POWER ON/STANDBY button to turn the power on.		
2	Press the MEMORY button. The "MEMORY" indicator flashes.		
3	Use the UP and DOWN buttons to call out the number at which you want to preset the station. The preset number flashes.		
4	Press the MEMORY button while the preset number is flashing.		
<p>After 1 second, the preset number switches to the preset tone display.</p> <p>"MEMORY" flashes for 10 seconds.</p>			

Notes on Presetting

- When an FM station is preset, the auto or monaural mode is also set, so check the display before presetting the station.
- If a station is preset at a button at which another station has previously been preset, the previous station is cleared and the new station is preset.
- The preset memory is not cleared immediately if the power cord is unplugged, but will be cleared if the cord is left unplugged over a long period of time. If this happens, preset the stations again. The memory is backed up for 24 hours.

Listening to Preset Stations

Example: Listening to the FM station preset at button 3: (Remote Control only)

1	Press the FUNCTION button on the remote control unit to call out "TUNER".		
2	Use the PRESET buttons to call out "3".		

- Load the disc with the disc holder open.
- Press the OPEN/CLOSE button (▲) once to open the disc tray, once again to close it.
- Set the disc securely in the tray guide at the center of the disc holder.
To play 8cm discs, place the disc in the sunken part at the center of the disc holder.
- Load discs with the labelled side facing up, being careful not to touch the disc surface.

- The disc tray can also be closed by pressing the PLAY (▶) button.
In this case, playback automatically starts from the first track on the disc (or if tracks are programmed, the first programmed track).
- When the disc holder is closed, the disc turns automatically for several seconds, and the number of tracks and total playing time appear on the display.

Handling the Disc Tray

Do not turn off the power or push or pull the disc tray when it is moving, as this may damage it.

If the cord of a set of headphones, etc., gets caught in the disc tray when it is closed, press the OPEN/CLOSE button (▲) again.

- Never set objects other than CDs in the disc tray, as this can cause damage.

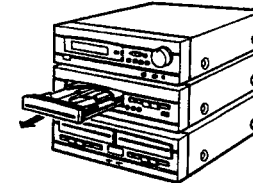

8 PLAYING CDs

Compact Discs

Discs which can be played



Only discs with this mark can be played.

- For CDVs, only the audio part is played (the video part is not played).

Disc	Remarks
CD	
CDV	Only the audio part is played.
CD single (8 cm)	

Loading Discs

When removing the disc from its case:

As shown in the diagram, grasp the disc along the edges, gently press down on the hole in the middle with a finger, and lift the disc. It should come out easily.



When setting the disc in the disc tray:

Always set the disc with the labelled side facing up. (Compact discs can only be played on one side.) For 8 cm CDs, set the disc in the sunken part in the middle of the tray.

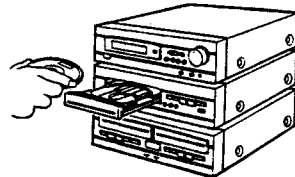

Cleaning Discs

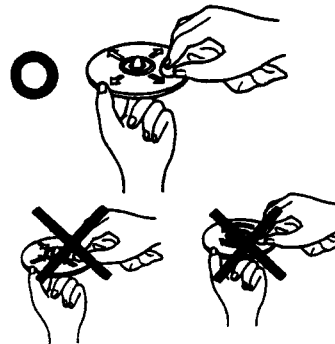

Dust, fingerprints, or spittle on the disc can cause noise or skipping.

If the disc is dirty or if the player does not work properly, clean the disc as follows:

- Hold the disc as shown in the diagram, with the signal surface facing up (the labelled side facing down).
- Using a soft cloth, wipe the disc gently from the inside towards the edges in straight lines (as shown by the arrows).

- Do not wipe from the edges towards the center or around the disc as you would wipe records.
- Do not use hard cloths or rub the disc, since this can scratch the signal surface.

Never use the following to clean discs:

- Solvents such as benzene or alcohol
- Cleaners containing abrasives
- Sprays or cleaner for records
- Anti-static products

Regular Playback

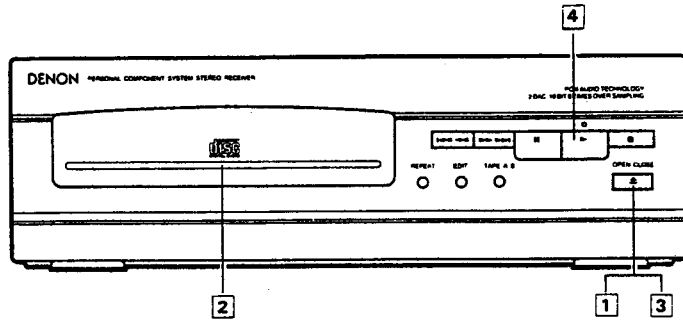

Example: Playing a CD with 15 tracks and a total playing time of 62 minutes 03 seconds, starting from track 1

1	Press the OPEN/CLOSE button. The disc tray opens.		
2	Set the CD in the disc tray. Refer to Page 13.		
3	Press the OPEN/CLOSE button. The disc tray closes. The display appears several seconds after the disc tray closes.		
4	Press the PLAY button.		
Operations marked R can also be performed using the remote control unit.			

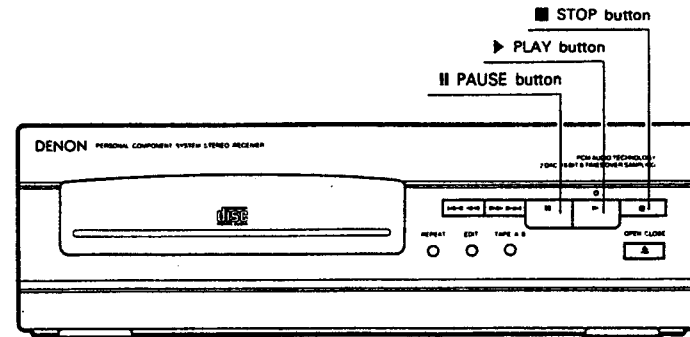

To stop playback temporarily:

Press the PAUSE button.		"▶ PLAY" turns off and " PAUSE" appears, and playback is paused at the point the button is pressed.
-------------------------	--	---

To resume playback:

Press the PLAY button.		" PAUSE" turns off and "▶ PLAY" appears, and playback is resumed at the point the button is pressed.
------------------------	--	--

To stop playback:

Press the STOP button.		
------------------------	--	--

NOTE:

- "00" is displayed on the track number section of the display for several seconds after the disc is set, while the data on the number of tracks, playing time, etc., is being read from the innermost section of the disc. After this, the number of tracks and total playing time appear.
- If no disc is loaded, if the disc is upside-down, or if the data on the innermost part of the disc cannot be read properly due to scratches or dirt.

Programmed Playback (remote control only)

NOTES

Use this function to set certain tracks to play in any order you want.

Example: Programming track 3 to play first, track 5 to play second CD with 25 tracks and a total playing time of 41 minutes, 37 seconds

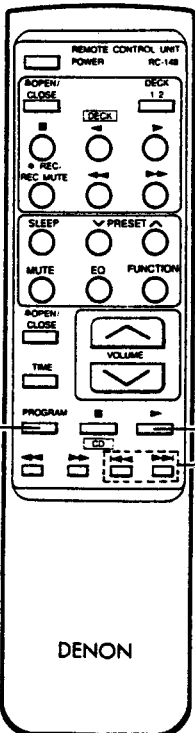
<p>1</p> <p>Press the PROGRAM button on the remote control unit.</p>		<p>TRACK 25 41' 37^s</p> <p>PROGRAM FLAT</p>
<p>2</p> <p>Press the ◀◀ or ▶▶ button to set track 3.</p>		<p>01 P - 03^s</p> <p>PROGRAM FLAT</p>
<p>3</p> <p>Press the PROGRAM button on the remote control unit.</p>		<p>TRACK 0 01' 14^s</p> <p>PROGRAM FLAT</p>
<p>4</p> <p>Press the ◀◀ or ▶▶ button to set track 5.</p>		<p>02 P - 05</p> <p>PROGRAM FLAT</p>
<p>5</p> <p>Press the PROGRAM button on the remote control unit.</p>		<p>TRACK 02 02' 37^s</p> <p>PROGRAM FLAT</p>
<p>6</p> <p>Press the ▶ (play) button.</p>		<p>TRACK 03 00' 01^s</p> <p>PROGRAM FLAT ▶</p>
<ul style="list-style-type: none"> • Set the program when the CD player is in the stop mode. • Programming is not possible when the CD is playing. • To change the track number continuously in step 4 above, press the ◀◀ or ▶▶ button. 		

- The numbers of the programmed tracks turn off once the tracks are played.
- The time display will read "— M — S" if a track with a number of 31 or greater is set in the program.
- With this set, up to 20 tracks with numbers between 1 to 99 can be set in the program.
- If you attempt to set a track number greater than the number of tracks on the disc, that track number will not be displayed when the button is pressed.
- Programming is also possible while the disc tray is open. In this case, track numbers greater than the number of tracks on the disc can be programmed, but these are ignored when the disc is played.
- No sound is produced for 4 seconds between tracks. This is so that 4-second blanks are created between tracks when programmed tracks are recorded on tapes.

- The entire program is cleared when the disc tray is opened or closed (by pressing the button).
- If you make a mistake when setting the program, either press the OPEN/CLOSE key or the STOP key twice and start over.
- Operations possible during programmed playback
The quick search, pause and skip monitor functions can be used during programmed playback. For the quick search function, to move to the beginning of the previous track, press the ◀◀ button once, then once again while the time display reads "DD M DD S". To move to the beginning of the following track, press the ▶▶ button once, regardless of the time display.

9 BEFORE RECORDING AND PLAYBACK

Cassette Tapes

■ Cautions on Handling

- C-120 cassette tapes
Avoid using 120-minute cassette tapes, as they have extremely thin tape which tends to get caught on the capstans or pinch rollers.
- Tape slack
If the tape is slack, it may get tangled or be damaged. Take up slack with a pencil, etc., before loading the cassette.

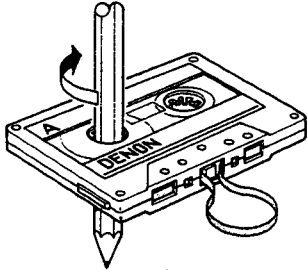

■ Protecting Cassette Tapes From Being Erased Accidentally

- Cassette tapes are equipped with accidental erasure prevention tabs. To protect recorded tapes from being erased accidentally, use a screwdriver, etc., and break these tabs off.
- To record on a cassette tape whose accidental erasure prevention tabs have been broken off, place a piece of cellophane tape over the hole.

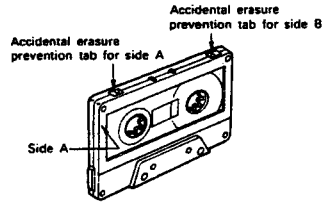

■ Cautions on Storing

- Avoid storing in the following places:
 - Hot, humid places
 - Dusty places
 - Places exposed to direct sunlight
 - Near magnetic forces (TVs, speakers, etc.)
- Store the cassette tape in a case equipped with stoppers to keep the tape from coming slack.

Using the Tape Counter

- Reset the counter to 0000 by pressing the COUNTER RESET button.
- The counter indicates the position of the tape for the deck indicated by the DECK 1 and DECK 2 indicators.
- If the playback mode is set directly after rewinding the tape in the recording or playback mode, the indication on the tape counter may differ slightly from the indication when recording or playback was actually started. To avoid this, set the deck to the stop mode first before setting the playback mode after rewinding the tape.

Auto Tape Selector Mechanism

This deck is equipped with an auto tape selector mechanism which uses the detection holes in the cassette halves to automatically set the recording bias and equalization best suited for that type of tape.

- Do not use ferrichrome tapes.
- Use metal tapes equipped with detection holes.

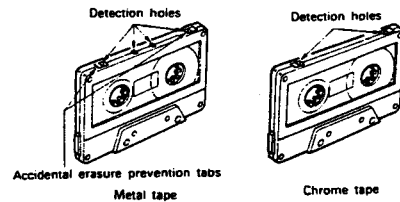

NOTES

- Set the cassette tape with the exposed side facing the inside of the set. Setting the cassette tape in the other direction can damage the set.
- Do not press the OPEN/CLOSE button during playback or recording. Always press the stop button before pressing the OPEN/CLOSE button.

Common for Deck 1 and Deck 2

• Loading

- ① Press the OPEN/CLOSE button (▲) to open the cassette tray.
- ② Set the tape in the cassette tray with the open side (on which tape is exposed) facing away from you.
- ③ Press the OPEN/CLOSE button again to close the tray.

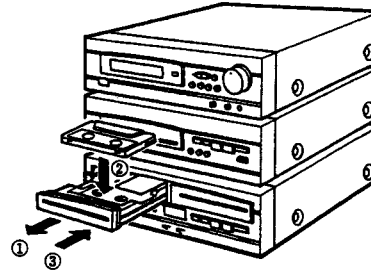

• Unloading

- ① Press the STOP button (■). (Deck 1 or Deck 2)
- ② Press the OPEN/CLOSE button (▲) to open the cassette tray.
- ③ Remove the cassette tape.

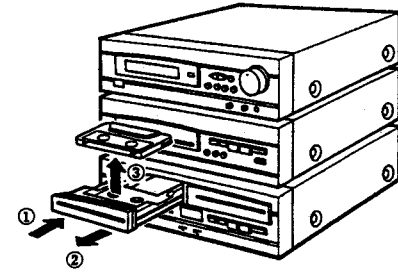

Check the following before recording or playing cassette tapes:

1. Is the head dirty? The sound quality will be poor if the head is dirty. Refer to Page 25.
2. Are the accidental erasure prevention tabs broken off? Recording is not possible if the accidental erasure prevention tabs broken off. Refer to Page 17.

Auto Reverse

This deck is equipped with an auto reverse mechanism, so cassette tapes can be played and recorded on both sides or played continuously without having to turn them over.

Direction of tape travel

This deck has two play buttons, one for the forward direction (front side) and another for the reverse direction (back side). The side being played can be changed during playback by pressing the opposite play button.

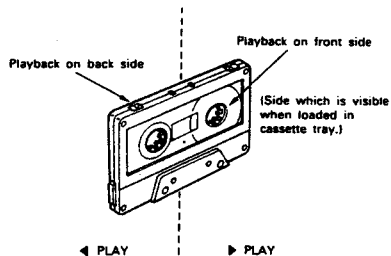

Reverse mode

Set the reverse mode switch (REV. MODE) as follows:

• **Single-side recording/playback mode** ()

In this position, only the front side or the back side of the cassette tape is played or recorded. (The tape stops automatically when the end of that side is reached.)

• **Double-side (reverse) recording/playback mode** ()

In this position, when the end of the front side is reached, recording or playback automatically switches to the back side and continues from there. (The tape stops automatically when the end of the back side is reached.)

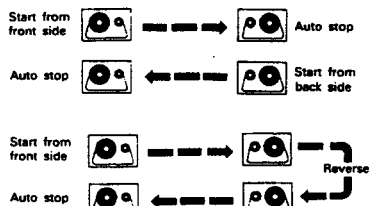

* If you start playing or recording from the back side, the tape will stop automatically at the end of the back side.

• **Continuous mode** ()

Playback continues until the STOP button is pressed, but stops automatically after both sides have been played five times.

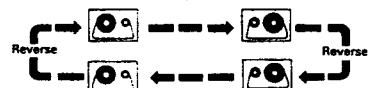

* The reverse recording/playback mode () is set automatically during recording.

• **Relay playback mode**

When tapes are loaded in both decks Playback continues from deck 1 onto deck 2, as shown on the diagram at the right.

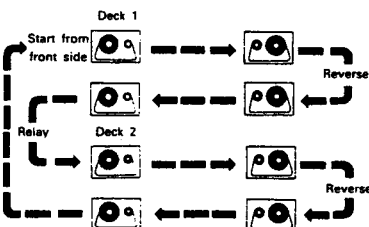

10 PLAYING CASSETTE TAPES (Single Side Playback, Double Side Playback and Continuous Playback)

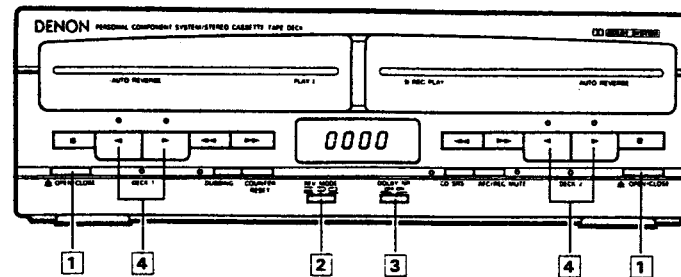

- For both Deck 1 and Deck 2
- When operating from the remote control unit, operation switches between Deck 1 and Deck 2 each time the DECK 1/2 button is pressed. The indicator for the selected deck (DECK 1 or DECK 2) lights.

<p>1</p> <p>Press the OPEN/CLOSE, and load a recorded tape into the tray. Refer to Page 17.</p>	<p>OPEN/CLOSE</p>
<p>2</p> <p>Set the reverse mode selector. Refer to Page 8.</p>	<p>Single side playback Double side playback Continuous playback</p> <p>REV. MODE</p>
<p>3</p> <p>Set the Dolby NR selector. Refer to Page 8.</p>	<p>DOLBY NR OFF ON</p> <p>Set the selector to "ON" for tapes recorded in Dolby NR.</p>
<p>4</p> <p>Press the play button (▶ or ◀).</p>	<p>▶ ◀</p> <p>Playback begins in the direction of the button which was pressed.</p>
<p>Press the button to stop playback. These operations can be performed from the remote control unit once tapes are loaded.</p>	
<p>Operations marked can also be performed using the remote control unit.</p>	

Using the MS (Music Search) Function

- Use this function to move to the beginning of the following selection or return to the beginning of the current selection. (For both Deck 1 and Deck 2)
- There must be blank spaces of at least 4 seconds between the selections on the tape for the search function to work.

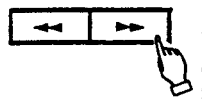
1	Press ▶ or ◀.		<ul style="list-style-type: none"> • In the rewind direction, playback starts from the beginning of the selection which is currently playing, and in the fast-forward direction, playback starts from the beginning of the following selection. • For the normal fast-forward or rewind operations, press the ■ stop button before pressing the ▶▶ or ◀◀ button. <p>The tape skips by a number of selections equal to the number of times the ▶▶ or ◀◀ button is pressed. For example:</p>
2	Press ▶▶ or ◀◀.		

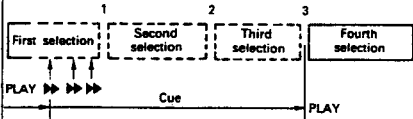

Operations marked **R** can also be performed using the remote control unit.

Display During the Music Search Operation

During the music search operation, the number of selections being skipped is indicated on the tape counter, and this number decreases each time a blank section is detected (for example, 3 → 2 → 1).

- When skipping back to a previous selection
- When skipping ahead to a following selection



11 CONVENIENT FUNCTIONS

Preset Equalizer Settings

This set includes preset equalizer settings which can be selected according to the type of music or application. There are six preset equalizer modes which can be called out easily either on the main unit or from the remote control unit. In addition, these modes are indicated on the receiver's display.

DISCO: Use this mode for strongly modulated sound.	SDB: Use this mode to create a more powerful bass sound.
VOCAL: Use this mode to create glossy vocals.	FLAT: Use this mode for straight, pure sound.
ROCK: Use this mode for powerful sound.	
BGM: Use this mode for easy listening.	

12 USING THE TIMER

Setting the Timer

Notes on Setting the Timer

- Always set the current time beforehand.
- Be sure to preset radio stations before setting the timer. (Refer to "Presetting AM and FM Stations" on Page 12.)
- Turn the standby switch off when not using the timer.

Types of Timers:

- TIMER:** This can be used to turn the power on and off at the same time each day. ("Good morning music")
- SLEEP TIMER:** This can be used to set the power to turn off in intervals of 10 minutes between 60 and 10 minutes, using the remote control unit. ("Good night music")

Power Failure

If there should be a power failure or if the power cord should be unplugged from the power outlet, "00:00" or the time at which the power failed flashes on the time display. If this happens, reset the current time. (Reset the current time and timer settings.)

Checking the Timer Settings

To check the timer settings, turn the receiver's power on then press the timer button. Next, press the ENTER/NEXT button repeatedly to display the following: Timer start mode → reception band, preset channel number and timer on time → timer off time.

Press the ENTER/NEXT button once again to return to the frequency display.

If the timer on or off times are not set, "00:00" flashes and the display does not switch to the next step.

Changing the Timer Settings

When timer setting operations are repeated, the old timer settings are cleared and the new ones are set.

Clearing the Timer Settings

Press the TIMER key once, then press it again while "F U N C" is displayed to clear the timer settings.

Cautions on Setting the Timer

The timer settings are given priority, so when the timer on time is reached, the function switches to that function set for the timer.

Setting the Timer

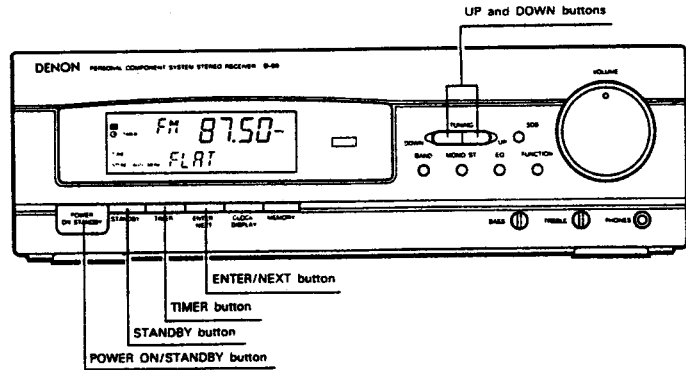

Example: Setting the timer to turn on at 12:35 and off at 12:56
Tuner (FM 102.50 MHz set at preset number "3")





1	Press the POWER ON/ STANDBY button to turn the power on.		
2	Press the TIMER button.		TIMER FUN C
3	Press the UP and DOWN buttons to display "TUNER:".		TIMER TUN ER
4	Press the ENTER/NEXT buttons.		TIMER FM 102.50 MHz AUTO MONO P - -
5	Press the UP and DOWN buttons to set the preset number. .		TIMER FM 102.50 MHz AUTO MONO P 3
6	Press the ENTER/NEXT buttons.		TIMER 00:00 MHz AUTO MONO ON

7	Use the UP and DOWN buttons to set hour at which the timer is to turn on.		TIMER 12:00 MHz AUTO MONO ON
8	Press the ENTER/NEXT button.		TIMER 12:00 MHz AUTO MONO ON
9	Use the UP and DOWN buttons to set minutes at which the timer is to turn on.		TIMER 12:35 MHz AUTO MONO ON
10	Press the ENTER/NEXT button.		TIMER 0:00 MHz AUTO MONO OFF
11	Use the UP and DOWN buttons to set hour at which the timer is to turn on.		TIMER 12:00 MHz AUTO MONO OFF
12	Press the ENTER/NEXT button.		TIMER 12:00 MHz AUTO MONO OFF
13	Use the UP and DOWN buttons to set minutes at which the timer is to turn on.		TIMER 12:56 MHz AUTO MONO OFF
14	Press the ENTER/NEXT button.		TIMER FM 102.50 MHz AUTO MONO FLAT
15	Press the STANDBY button.		TIMER FM 102.50 MHz AUTO MONO FLAT
16	Press the POWER ON/ STANDBY button.		TIMER 10.05

Press the POWER ON/STANDBY button.
When the STANDBY button is pressed and the mark is lit, the timer will function at the same times each day. To turn the timer off, press the STANDBY button to turn the mark off.

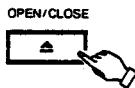

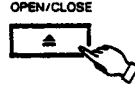

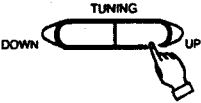
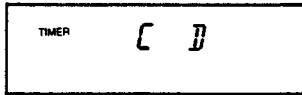

Ways to Use the Timer

Example: Waking up to the music of a compact disc

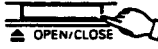
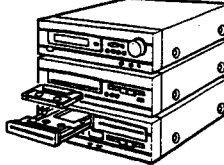
1	Press the receiver's POWER ON/STANDBY button to turn the power on.		
2	Press the CD player's OPEN/CLOSE button to open the disc tray. R		
3	Load the CD in the disc tray. Refer to Page 13.		
4	Press the CD player's OPEN/CLOSE button again to close the disc tray. R		
5	Press the receiver's TIMER buttons.		
6	Use the receiver's UP and DOWN buttons to display "CD".		
7	Follow steps 6 to 16 under "Setting the Timer" on Page 20.		
Operations marked R can also be performed using the remote control unit.			

Ways to Use the Timer

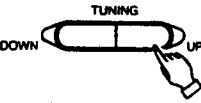
Example: Waking up to the music of a cassette tape

1	Press the receiver's POWER ON/STANDBY button to turn the power on.		
2	Press the cassette deck's OPEN/CLOSE button to open the tray. R		
3	Load the cassette tape in the tray. Refer to Page 17.		
4	Press the cassette deck's OPEN/CLOSE button again to close the tray. R		
5	Press the receiver's TIMER buttons.		
6	Use the receiver's UP and DOWN buttons to display "TAPE".		
7	Follow steps 6 to 16 under "Setting the Timer" on Page 20.		
<ul style="list-style-type: none"> • The tape will be played in the direction indicated by the tape direction indicators. Check that the tape direction and reverse mode settings are as desired. (Refer to "Using the Auto Reverse Function" on Page 18.) • When using the timer, the tape is played in direction indicated for Deck 2. 			
Operations marked R can also be performed using the remote control unit.			

Setting the Sleep Timer

Example: Setting the power to turn off in 30 minutes (remote control only)

1	Currently receiving FM 87.50 MHz		
2	Press the SLEEP button.		
3	Press the SLEEP button 3 times successively.		
4	The original display reappears after 5 seconds.		

To cancel the sleep timer:
Press the SLEEP button repeatedly until the display reads "0". The power turns off. Now press the POWER switch to turn the power back on.

NOTES

- If the sleep timer is set to turn the power off before the timer off time, the sleep timer is given priority, and the power turns off when the sleep timer time is reached.
- Do not press the TIMER STANDBY button after the power has been turned on with the timer. If this is done, the timer will not function properly.
- If the same time is set for the on time and off time, the power will not turn on even if the standby indicator is on.
- If the timer is set for an AM or FM station and the timer on time is reached while listening to another station, the station switches to the station which was set with the timer.

13 RECORDING CASSETTE TAPES

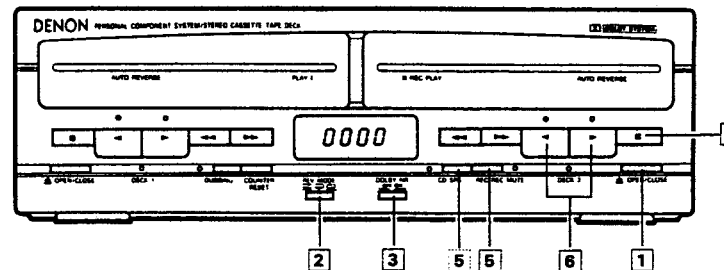

- Check that the accidental erasure prevention tabs on the tape onto which you want to record are intact. Recording is not possible if the accidental erasure prevention tabs are broken off. Refer to Page 17.

1	Press the OPEN/CLOSE button for Deck 2 and load the tape onto which you want to record. Refer to Page 17.							
2	Set the reverse mode selector. Refer to Page 18.							
3	Set the DOLBY NR selector. Refer to Page 8.	<p>Set to the "ON" position to record in Dolby NR.</p>						
4	<table border="1" style="width: 100%;"> <tr> <td style="width: 33%;">To record the radio:</td> <td style="width: 33%;">To record from a VDP or VCR:</td> <td style="width: 33%;">To record a CD:</td> </tr> <tr> <td> Press the receiver's band selector button. Select the station you want to record. </td> <td> Press the receiver's FUNCTION button and select PHONO or LINE. Start playback on the VDP or VCR. </td> <td> Set the disc in the CD player. Refer to Page 13. </td> </tr> </table>	To record the radio:	To record from a VDP or VCR:	To record a CD:	Press the receiver's band selector button. Select the station you want to record.	Press the receiver's FUNCTION button and select PHONO or LINE. Start playback on the VDP or VCR.	Set the disc in the CD player. Refer to Page 13. 	
To record the radio:	To record from a VDP or VCR:	To record a CD:						
Press the receiver's band selector button. Select the station you want to record.	Press the receiver's FUNCTION button and select PHONO or LINE. Start playback on the VDP or VCR.	Set the disc in the CD player. Refer to Page 13. 						
5	Press the REC/REC MUTE button. R	<p>The recording indicator lights.</p>						
6	Press the play button (▶ or ◀). (Recording starts) R	<p>The recording indicator lights.</p>						
To stop recording, press the ■ button. R								
Operations marked R can also be performed using the remote control unit.								

Edited Recording onto Sides A and B of a Tape (EDIT)





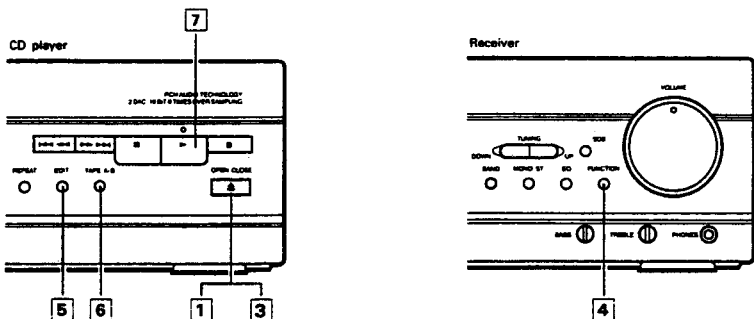

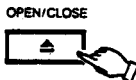
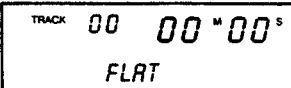
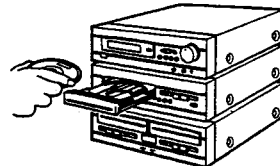
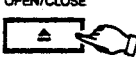
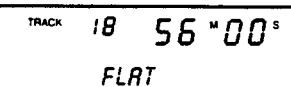

NOTES

- For discs containing 21 or more tracks, editing is not possible for track numbers 21 and up. (Editing is only possible for up to 20 tracks.)
- Editing is cancelled if the CD player's stop button (■) or OPEN/CLOSE button (▲) is pressed.
- Set the deck's reverse mode selector to the  position.
- Set the cassette tape onto which you want to record in Deck 2 with side A on the top when performing the editing operations. The beginning of the tape is searched for automatically before recording starts.
- Note that in some cases it is not possible to record all the tracks on the CD onto the tape, even if the tape is longer than the total playing time of the CD, due to the combination of the tracks being recorded onto sides A and B.

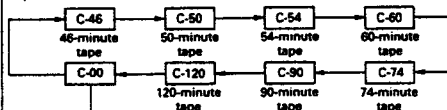

Automatic Edited Recording – Recording the CD's Tracks in Order

<p>1 Press the CD player's OPEN/CLOSE button to open the disc tray.</p>		
<p>2 Load the CD in the disc tray. Refer to Page 13.</p>		
<p>3 Press the CD player's OPEN/CLOSE button. The disc tray closes.</p> <p>The display appears several seconds after the disc tray closes.</p>		

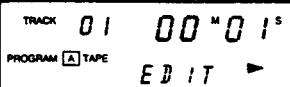
<p>4 Press the receiver's FUNCTION button to set the function to "CD".</p>		
<p>Press the EDIT button to select the length of the tape. Press the EDIT button four times when using a 60-minute (C-60) tape. (The tape length is the total time for sides A and B.)</p>		
<p>The display changes as follows each time the EDIT button is pressed:</p>  <p>When this is displayed, the desired recording time can be set.</p> <p>Example: For a 36-minute tape: Use the  or  button to set to "36".</p> <p>If you make a mistake, press the EDIT button to display "C00", then start over.</p>		
<p>6 Press the CD player's TAPE A/B button. The display switches between the display for sides A and B each time the button is pressed. (Use this to check the extra time on side B.)</p>		
<p>7 Press the CD player's (play) button.</p>		
<p>Operations marked R can also be performed using the remote control unit.</p>		
<p>NOTE: Only the CD player's STOP and OPEN/CLOSE keys and the cassette deck's STOP key will function during edited recording.</p>		

Programmed Edited Recording – Recording Certain Tracks in Any Order





- 1 Follow the instructions under "Programmed Playback" on Page 16 to program the tracks.
- 2 Perform steps 5 to 7 under "Automatic Edited Recording" on Page 23.

CAUTIONS

- When performing edited recording onto a tape which already contains a recording and which is longer than the set time, the previously recorded section after the newly recorded part of side B is not erased, so erase the tape before starting.
- When the editing function is used, a blank section of 4 seconds is created between all of the selections on the tape. Because of this, the times of the actual blank sections between the tracks on the disc and the blank sections between the selections on the tape are different, so the displayed time is slightly different from the actual remaining time on the tape.

14 UNATTENDED RECORDING

Example: Unattended recording of radio programs ("air check")

1	Press the receiver's POWER ON/STANDBY button to turn the power on.		
2	Press the Deck 2 OPEN/CLOSE button to open the tray. R		
3	Load the cassette tape onto which you want to record into the tray. Refer to Page 17.		
4	Press the Deck 2 OPEN/CLOSE button again to close the tray. R		
5	Press the receiver's TIMER button.		TIMER FUN C
6	Press the receiver's UP and DOWN button to display "AIR.CH".		TIMER AIR.CH
7	Perform steps 4 to 16 under "Setting the Timer" on Page 20.		
<ul style="list-style-type: none"> • When recording using the timer, the tape is played in direction indicated for Deck 2. 			

15 CONNECTIONS TO OTHER COMPONENTS

Connect as shown on the diagram below.

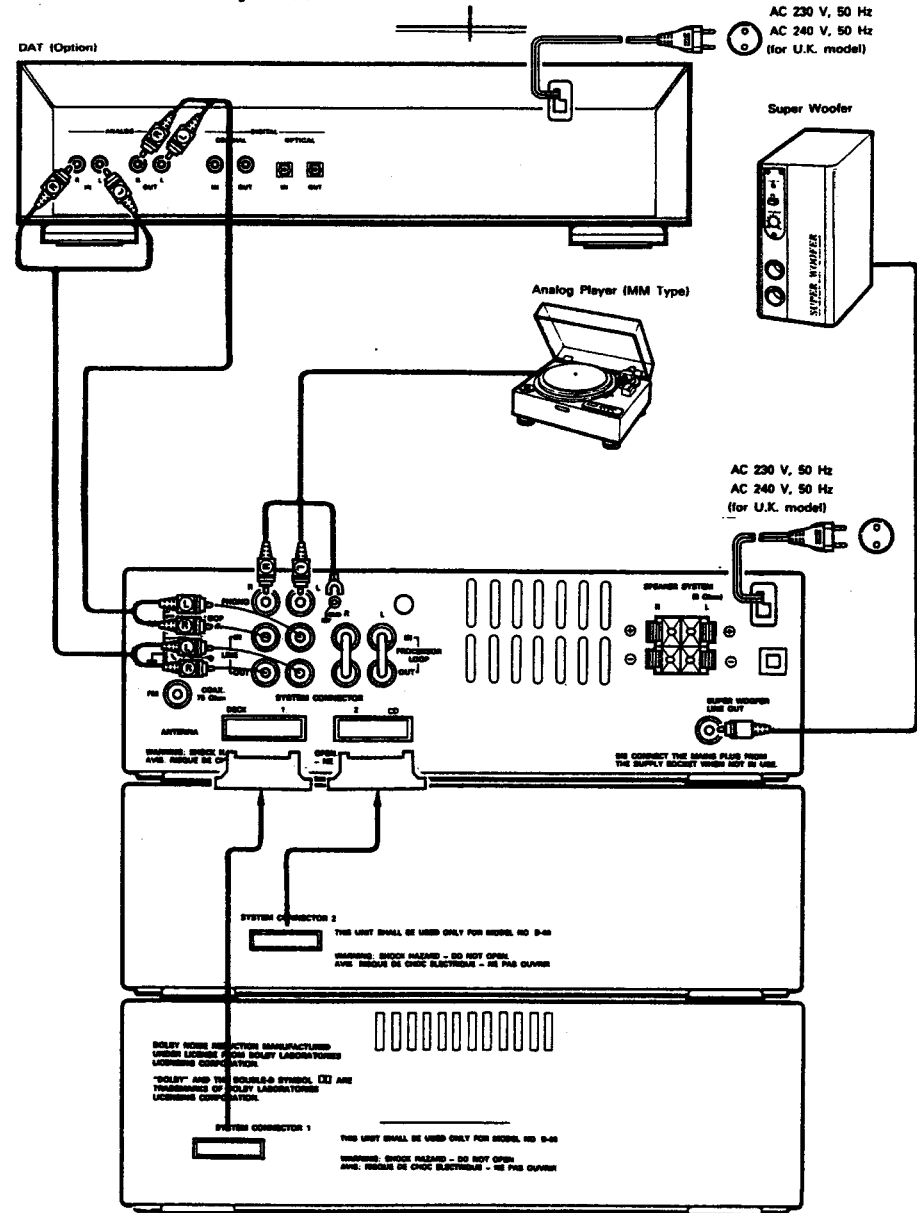

16 TROUBLESHOOTING

1. Check that connections are proper.
2. Check that you are operating the system according to the instructions in the manual. Check the following points if the system does not seem to be working properly. If the problem is not solved after checking these points carefully, the system may be malfunctioning. Turn the power off and contact your store of purchase or your nearest DENON service center or office.

	Symptom	Cause	Measures	See Page
Common	Power does not turn on when POWER button pressed.	<ul style="list-style-type: none"> • Power cord not plugged into outlet. 	<ul style="list-style-type: none"> • Plug cord into outlet properly. 	5
	No sound produced from speakers.	<ul style="list-style-type: none"> • VOLUME control set to minimum. • Headphones are connected. • Speaker cords not connected to speaker terminals. 	<ul style="list-style-type: none"> • Turn VOLUME control clockwise (\curvearrowright). • Disconnect headphones. • Connect speaker cords properly. 	7 7 5
	Trebles not produced or stereo effect not clear.	<ul style="list-style-type: none"> • Speaker's polarities (\oplus and \ominus) not matched. 	<ul style="list-style-type: none"> • Connect speaker cords properly. 	5
	Source other than the one desired is heard.	<ul style="list-style-type: none"> • Function selector buttons not set properly. 	<ul style="list-style-type: none"> • Set to desired function. 	7
Deck	Recording not performed when REC/REC MUTE button pressed.	<ul style="list-style-type: none"> • No cassette tape loaded. • Cassette tape's tabs broken off. 	<ul style="list-style-type: none"> • Load tape. • Apply cellophane tape over holes. 	17 17
	Sound is interrupted during playback or recording, or treble sound low.	<ul style="list-style-type: none"> • Heads dirty. • Tape stretched. 	<ul style="list-style-type: none"> • Clean. • Replace tape. 	25 -
	Wow is heavy during playback or recording.	<ul style="list-style-type: none"> • Capstans or pinch rollers dirty. 	<ul style="list-style-type: none"> • Clean. 	25
Receiver	Hissing noise heard during FM reception.	<ul style="list-style-type: none"> • Antenna not pointed in proper direction. • Signals weak. 	<ul style="list-style-type: none"> • Change direction of antenna. • Install outdoor antenna. 	6 5
	Hissing or scratchy noise heard during AM reception.	<ul style="list-style-type: none"> • Noise from TV or interference from other stations. 	<ul style="list-style-type: none"> • Turn TV off. • Set system in different direction. • Install outdoor antenna. 	- - 6
	Humming noise heard during AM reception.	<ul style="list-style-type: none"> • Signals over power cord modulated by power source frequency. 	<ul style="list-style-type: none"> • Plug in cord in opposite direction. • Install outdoor antenna. 	5 5
CD Player	Disc loaded but number of tracks not displayed.	<ul style="list-style-type: none"> • Disc loaded upside-down. • Disc dirty. • Non-standard disc loaded. 	<ul style="list-style-type: none"> • Reload disc. • Clean disc. • Replace with standard disc. 	13 13 13
	Operation not performed when buttons pressed, or playback stops in middle of track.	<ul style="list-style-type: none"> • Disc loaded upside-down. • Foreign object in disc holder. • Disc dirty. • Disc scratched. 	<ul style="list-style-type: none"> • Reload disc. • Remove disc and remove foreign object. • Clean disc. • Replace with non-scratched disc. 	13 13 13 -
	Sound skips.	<ul style="list-style-type: none"> • Dust, fingerprints, or spittle on disc. • Disc scratched. • Player set in shaky, unstable place. 	<ul style="list-style-type: none"> • Clean disc. • Replace with non-scratched disc. • Set player in stable place. 	13 - -

Normal operation may not be possible if there is dirt or other substances on the surface of the internal objective lens or sensor.

These parts must be cleaned periodically depending on the place of installation.

For details, contact your store of purchase.

Avoid using ultrasonic humidifiers nearby.

If ultrasonic humidifiers are used nearby, the calcium, etc., included in the water may be scattered into the air, causing white dust to accumulate on the surface of the objective lens or sensor, resulting in improper operation.

Condensation Water droplets (or condensation) may form on the optical lens or disc in the following cases:

- Just after a heater is turned on in the room.
- When the set is placed in a steamy or humid room.
- When the set is moved abruptly from a cold place to a warm room.

If Condensation Occurs

The signals on the disc cannot be read properly and the CD player may not operate properly.

To get rid of the condensation, turn the power on and let the set sit for about one hour. Operation should be normal after this.

This system consists of precision components using microprocessors. Avoid using it in places where there is much external noise. If used in such places, the system may not operate properly, but this is not a problem with the system. If the system does not operate properly, try performing the desired operation again.

17 IMPORTANT INFORMATION

- **Cleaning the Head**
After the cassette deck is used for a while, powder from tapes and dirt get on the head, decreasing the sound quality.

NOTE:

Some cleaning sets sold in stores have a polishing effect and can damage the head.

- **Demagnetizing the Head**

The head becomes magnetized after the deck is used over a long period of time or if the head is exposed to magnetic forces. This results in noise and reduced treble.

If the head is magnetized, use a cassette tape head demagnetizer (eraser), available in stores, and demagnetize it.

- For details, read the demagnetizer's operating instructions.

18 SPECIFICATIONS

■ Receiver Section (UDRA-60)

● Power Amplifier Section

Rated Output Power:

30 W Per channel, min. RMS, at 8 ohms from 40 Hz to 20 kHz with more than 0.5% total harmonic distortion.
0.1% at 1 kHz

Total harmonic distortion:

0.1% at 1 kHz

● Pre-amplifier Section

Input sensitivity / Impedance:

PHONO: 2.5 mV/47 kohms, LINE: 150 mV

Super Dynamic Bass:

80 Hz + 8 dB

Tone Control:

BASS: 100 Hz ± 8 dB TREBLE: 10 kHz ± 8 dB

● FM Section

Tuning frequency range:

87.50 MHz ~ 108.00 MHz (50 kHz step)

Usable sensitivity:

1.5 µV (14.8 dBf)

Signal to noise ratio (A-weighted):

Mono: 78 dB Stereo: 75 dB

Total harmonic distortion:

Mono: 0.1% Stereo: 0.3%

Frequency response:

20 Hz - 15 kHz + 0.5 dB, -2 dB

Stereo separation:

40 dB (1 kHz)

● MW Section

Tuning frequency range:

522 kHz ~ 1611 kHz (9 kHz step)

Usable sensitivity:

18 µV

Signal to noise ratio:

52 dB

● LW Section

Tuning frequency range:

153 kHz ~ 279 kHz (1 kHz step)

Usable sensitivity:

35 µV

Signal to noise ratio:

52 dB

● Power supply:

AC 230 V, 50 Hz

● Power consumption:

80 W

● Dimensions:

270 (W) × 86.5 (H) × 248 (D) mm (10-5/8" × 3-13/32" × 9-49/64")

● Weight:

4 kg (8 lbs 13 oz)

■ CD Player Section (UCD-60)

● Audio Section

Sampling frequency:

44.1 kHz

Frequency response:

5 Hz ~ 20 kHz

Dynamic range:

90 dB

Signal to noise ratio:

90 dB

Total harmonic distortion:

0.05% (1 kHz)

Output filter:

Digital

● Dimensions:

270 (W) × 86.5 (H) × 235 (D) mm (10-5/8" × 3-13/32" × 9-1/4")

● Weight:

1.9 kg (4 lbs 3 oz)

■ Cassette Deck Section (UDR-60)

● Type:

Horizontal 4-track 2-channel Auto Reverse Double Cassette Deck

● Head

Record & playback:

Hard permalloy (P head & R/P head)

Erase:

Double gap ferrite head × 1

Tape speed:

4.75 cm/S

Usable tapes:

Normal, chrome and metal tapes

● Audio Section

Frequency response:

50 Hz ~ 16 kHz ± 3 dB (metal tape)

Signal to noise ratio:

60 dB (Dolby B NR)

● Dimensions:

270 (W) × 86.5 (H) × 235 (D) mm (10-5/8" × 3-13/32" × 9-1/4")

● Weight:

3 kg (6 lbs 10 oz)

■ Speaker Section (USC-60)

● Type:

2-way Speaker System

Input impedance:

8 ohms

Frequency response:

50 Hz ~ 20 kHz

Max input power:

50 W

Sound pressure level:

89 dB (1 m · 1 W)

● Dimensions:

172 (W) × 257 (H) × 235 (D) mm (6-25/32" × 10-1/8" × 9-1/4")

● Weight:

4 kg (8 lbs 13 oz)

■ Remote Control Unit (RC-148)

● Type:

Infrared pulse

Number of buttons:

26

Batteries:

R6P/AA type (two batteries)

Max. external dimensions:

47 (W) × 173 (H) × 14 (D) mm (1-27/32" × 6-13/16" × 35/64")

● Weight:

100 g (approx. 3.5 oz) (including batteries)

* Maximum dimensions include controls, jacks, and covers. (W) = width, (H) = height, (D) = depth

● For improvement purposes, specifications and functions are subject to change without advanced notice.

18 TECHNISCHE DATEN

■ Empfänger-Abteilung (UDRA-60)

● Leistungsverstärker-Abteilung

Geschätzte Ausgangsleistung:

30 W pro Kanal, min. RMS, bei 8 ohm von 40 Hz bis 20 kHz und mehr als 0,5% totale harmonische Verzerrung.
0,1% bei 1 kHz

Totale harmonische Verzerrung:

0,1% bei 1 kHz

● Vorverstärker-Abteilung

Eingangsempfindlichkeit / Impedanz:

PHONO: 2,5 mV/47 kohm, LINE: 150 mV

Hochdynamischer Baß:

80 Hz + 8 dB

Tonkontrolle:

Baß (BASS): 100 Hz ± 8 dB Höhen (TREBLE): 10 kHz ± 8 dB

● FM-Abteilung

Empfangsfrequenzbereich:

87,50 MHz ~ 108,00 MHz (50 kHz Schritt)

Brauchbare Empfindlichkeit:

1,5 µV (14,8 dBf)

Signal / Rausch-Verhältnis

Mono: 78 dB Stereo: 75 dB

(A-Belastung):

Mono: 0,1% Stereo: 0,3%

Totale harmonische Verzerrung:

Mono: 0,1% Stereo: 0,3%

Frequenzgang:

20 Hz - 15 kHz + 0,5 dB, -2 dB

Stereo-Trennung:

40 dB (1 kHz)

● MW-Abteilung

Empfangsfrequenzbereich:

522 kHz ~ 1611 kHz (9 kHz Schritt)

Brauchbare Empfindlichkeit:

18 µV

Signal / Rausch-Verhältnis:

52 dB

● LW-Abteilung

Empfangsfrequenzbereich:

153 kHz ~ 279 kHz (1 kHz Schritt)

Brauchbare Empfindlichkeit:

35 µV

Signal / Rausch-Verhältnis:

52 dB

● Stromversorgung:

230 V Wechselstrom, 50 Hz

● Stromverbrauch:

80 W

● Abmessungen:

270 (B) × 86,5 (H) × 248 (T) mm

● Gewicht:

4 kg

■ CD-Spieler-Abteilung (UCD-60)

● Audio-Abteilung

Sampling Frequenz:

44,1 kHz

Frequenzgang:

5 Hz ~ 20 kHz

Dynamischer Bereich:

90 dB

Signal / Rausch-Verhältnis:

90 dB

Totale harmonische Verzerrung:

0,05% (1 kHz)

AusgangsfILTER:

Digital

● Abmessungen:

270 (B) × 86,5 (H) × 235 (T) mm

● Gewicht:

1,9 kg

■ Cassettendeck-Abteilung (UDR-60)

● Typ:

Horizontales doppeltes Cassettendeck, 4-Spur, 2-Kanal,

automatische Richtungsumschaltung

● Kopf

Aufnahme & Wiedergabe:

Hartes Permalloy (Wiedergabekopf & Aufnahme-/Wiedergabekopf)

Löschung:

Doppelspaltkopf × 1

Bandgeschwindigkeit:

4,75 cm/S

Bandarten:

Normal, Chrom und Metallbänder

● Audio-Abteilung

Frequenzgang:

50 Hz ~ 16 kHz ± 3 dB (Metallband)

Signal / Rausch-Verhältnis:

60 dB (Dolby B NR)

● Abmessungen:

270 (B) × 86,5 (H) × 235 (T) mm

● Gewicht:

3 kg

■ Lautsprecher-Abteilung (USC-60)

● Typ:

2-Stück Lautsprechersystem

Eingangsimpedanz:

8 ohm

Frequenzgang:

50 Hz ~ 20 kHz

Maximale Eingangsleistung:

50 W

Klangdruckpegel:

89 dB (1 m · 1 W)

● Abmessungen:

172 (B) × 257 (H) × 235 (T) mm

● Gewicht:

4 kg

■ Fernbedienung (RC-148)

● Typ:

Infrarot Impuls

Anzahl Tasten:

26

Batterien:

Typ R6P/AA (zwei Batterien)

Maximale äußere Abmessungen:

47 (B) × 173 (H) × 14 (T) mm

● Gewicht:

100 g (einschließlich Batterien)

* Max. Abmessungen einschließlich Regler, Buchsen und Abdeckungen. (B) = Breite, (H) = Höhe, (T) = Tiefe

● Änderungen der äußeren Aufmachung und technischen Daten zwecks Produktverbesserung sind möglich ohne Vorankündigung.

RECEIVER SECTION

DISASSEMBLY PROCEDURES

(Follow these procedures in reverse order to reassemble.)

1. Removing the top cover and front panel

- ① Remove the six screws fastening the top cover.
- ② Lift the top cover in the direction of the arrow.
The top cover is caught in the three ribs in the front panel, so lift it straight upwards.

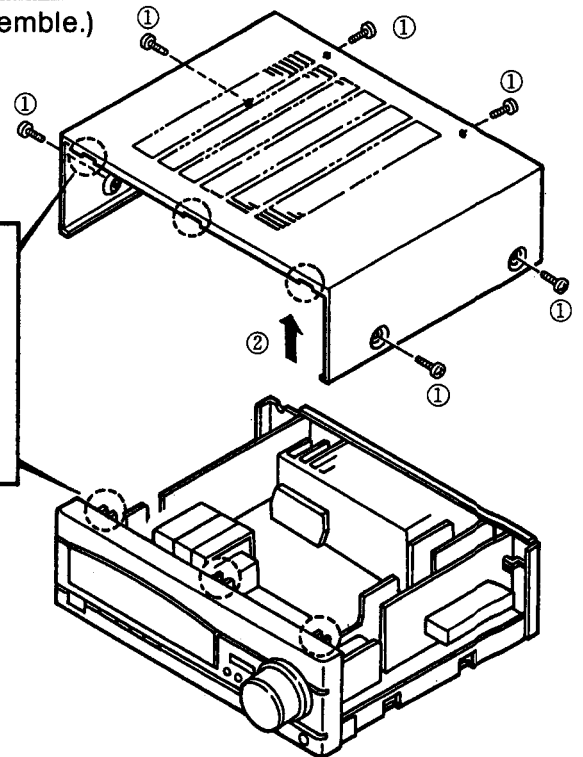
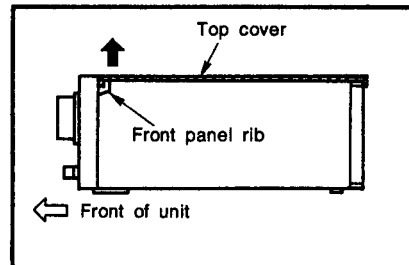

- ③ Remove the main volume knob assembly in the direction of the arrow, and remove the nut fastening the volume knob.
- ④ Remove the two knobs.
- ⑤ Disconnect connectors CN33A and CN5A connecting the amplifier unit and display unit, and disconnect the ground terminal.

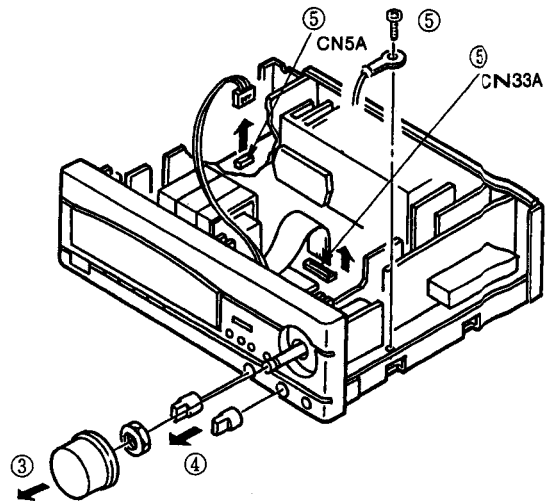

- ⑥ Set the unit up as shown in the diagram, then remove the two screws fastening the foot assembly.
- ⑦ Unlatch the hook of the front panel from the chassis and remove the front panel in the direction of the arrow.

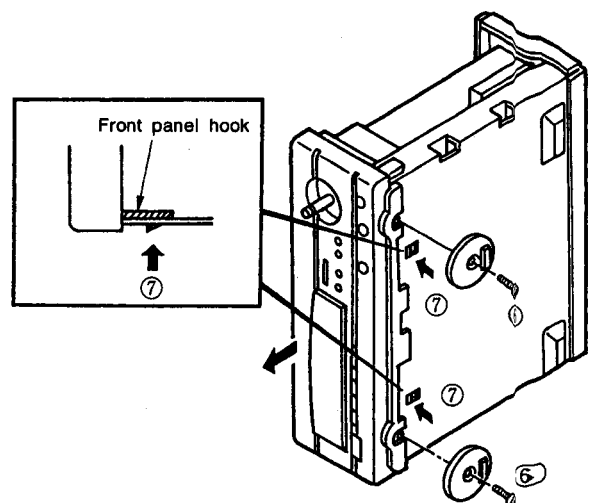

RECEIVER SECTION

2. Removing the printed wiring boards

TONE UNIT IU-2410B

- ① Remove the two screws fastening the tone unit, then remove the printed wiring board in the direction of the arrow.

DISPLAY UNIT KU-9260B-2

- ② Remove the three screws fastening the display unit, then remove the printed wiring board in the direction of the arrow.
- * Before removing the main unit's circuit boards, remove the two screws fastening the rear panel, then slide the rear panel in the direction of the arrow.

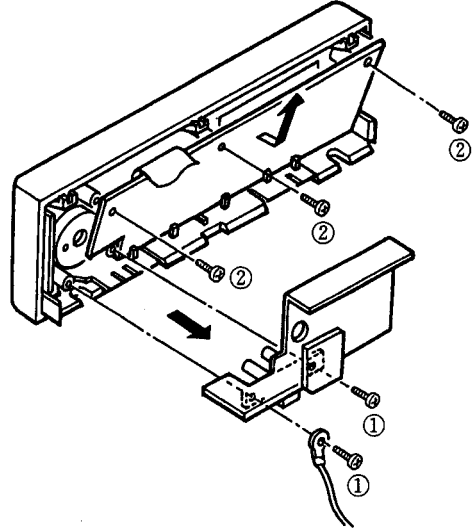

- * Before removing the main unit's circuit boards, remove the two screws fastening the rear panel, then slide the rear panel in the direction of the arrow.

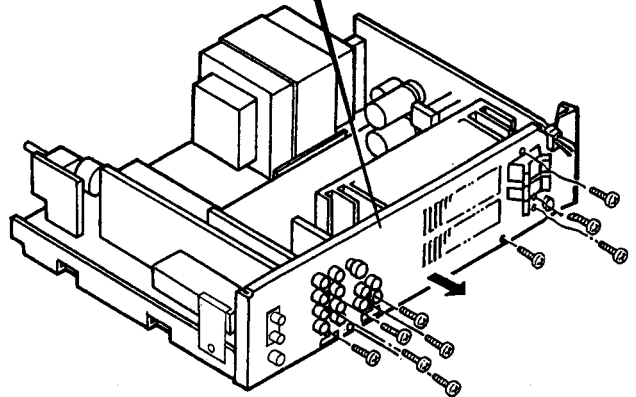
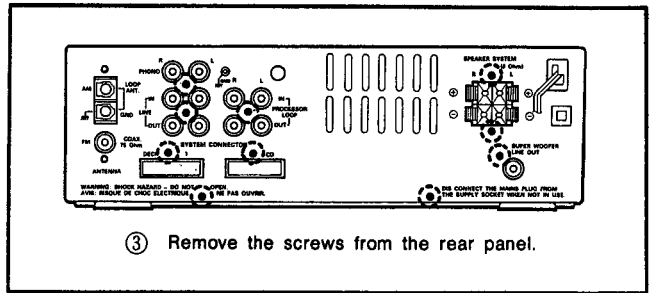

TUNER UNIT KU-9258B-1

- ① Remove the two screws which attach the tuner.
- ② Disconnect the tuner unit from the connector connecting it, then remove the printed wiring board in the direction of the arrow.

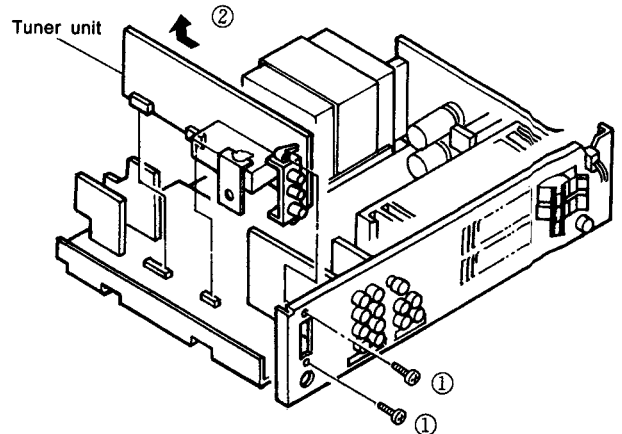

RECEIVER SECTION

EQ UNIT KU-9258B-2

- ① Disconnect the GRA-EQ unit from the connector connecting it, then remove the printed wiring board in the direction of the arrow.

MASTER VOLUME UNIT KU-9260B-4

- ② Disconnect the master volume unit from the connector connecting it, then remove the printed wiring board in the direction of the arrow.

INPUT UNIT IU-2410B-3

- ③ Disconnect the input unit from the connector connecting it, then remove the printed wiring board in the direction of the arrow.

PROCESSOR LOOP UNIT KU-9260B-6

- ④ Disconnect the processor loop unit from the connector connecting it, then remove the printed wiring board in the direction of the arrow.

POWER UNIT KU-9260B-3

- ① Remove the four screws fastening the power transformer.
- ② Disconnect the power unit from the connector connecting it, then remove the printed wiring board in the direction of the arrow.
- ③ Remove the solder on the terminals connecting the power transformer and power unit.
- ④ When reinstalling the transformer, line up the hooks in the transformer's bracket with the holes and install.

AMPLIFIER UNIT KU-9260B-1

- ① Remove the three screws fastening the radiator and chassis.
- ② Remove the two screws fastening the amplifier unit.
- ③ Unlatch the four PCB holders fastening the amplifier unit, using radio pliers, etc.
- ④ Slide the rear panel to the back and remove the amplifier unit in the direction of the arrow.

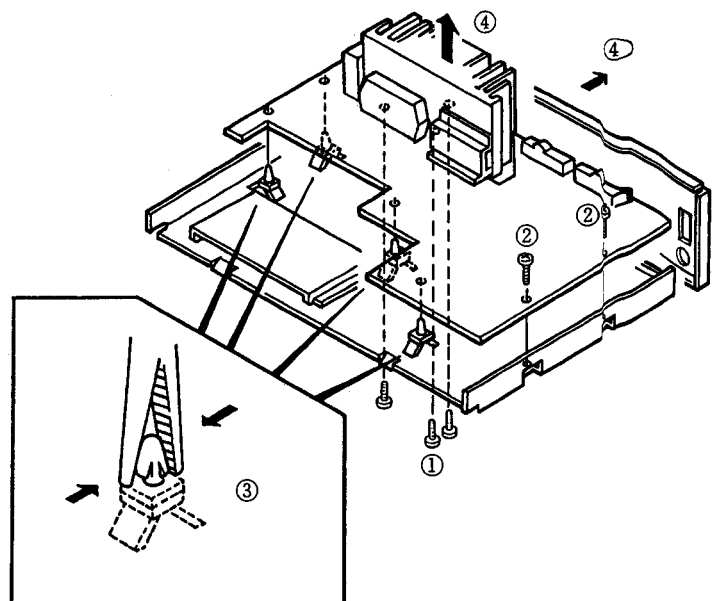
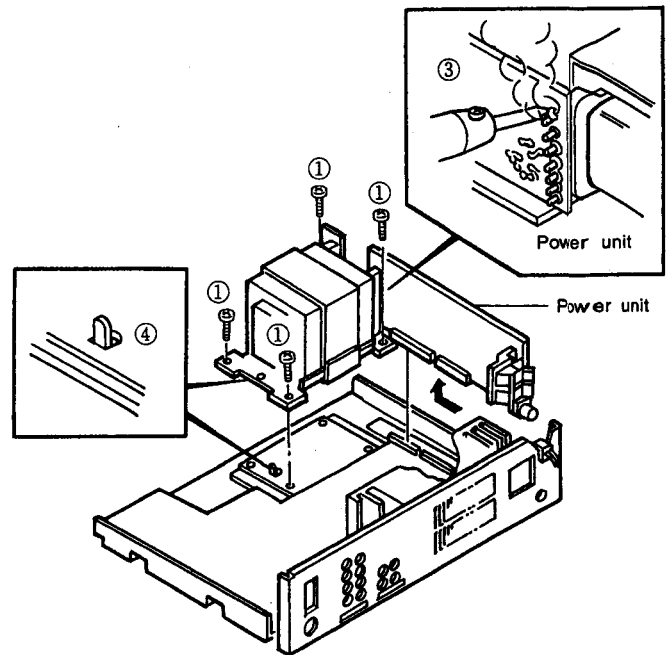
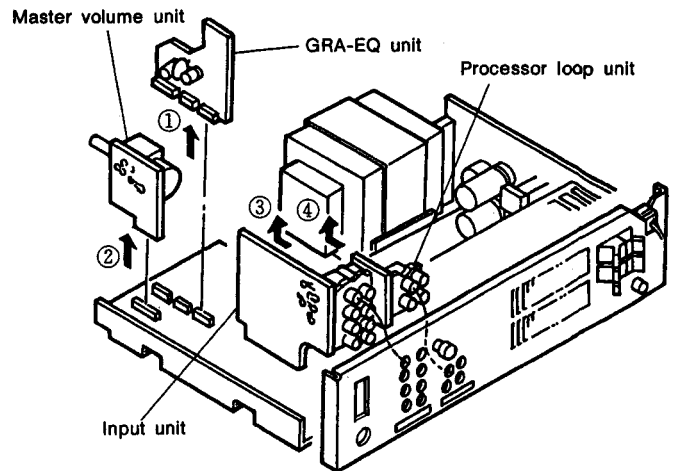

RECEIVER SECTION

BLOCK DIAGRAM
(TUNER SECTION)

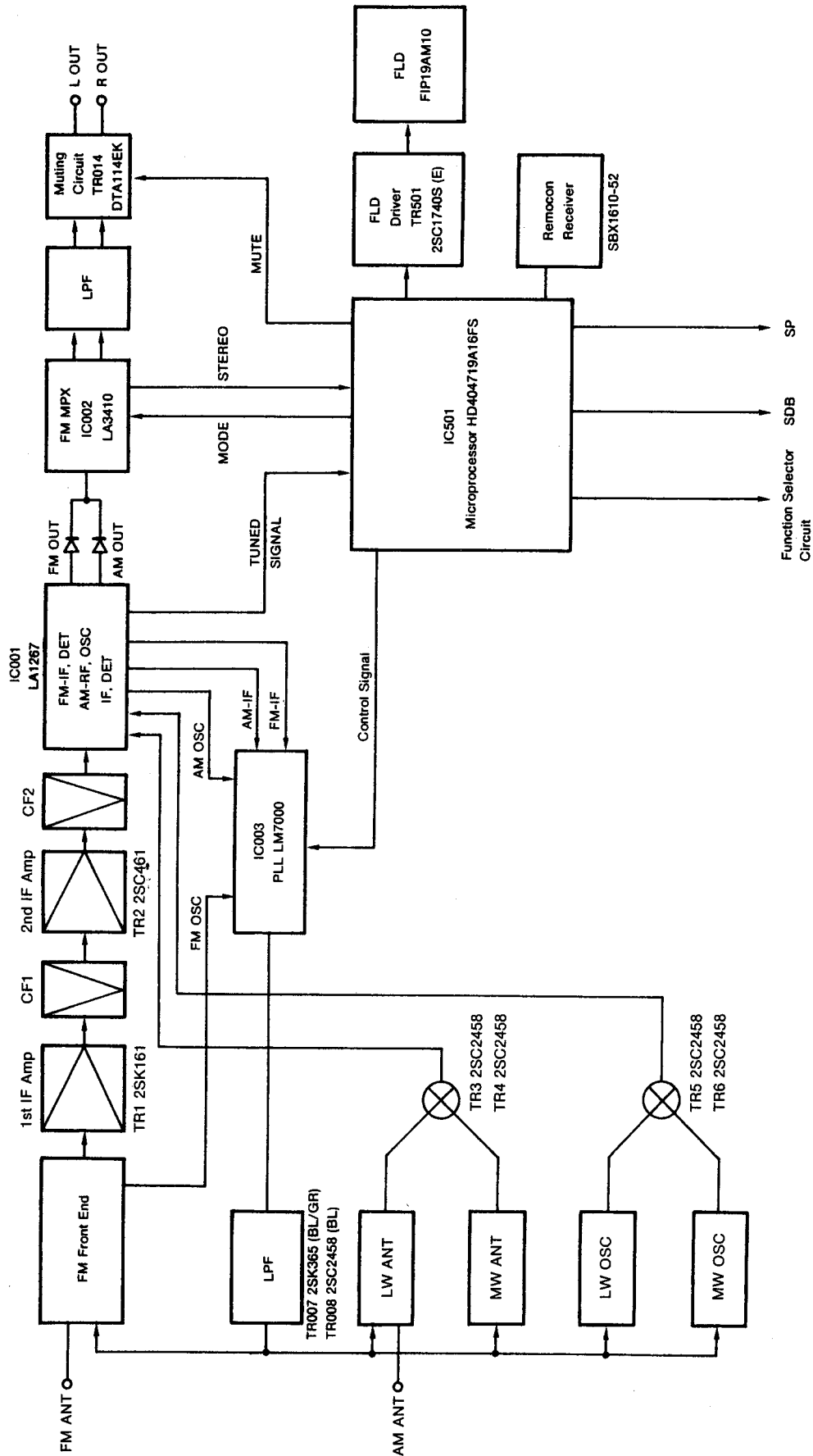

RECEIVER SECTION

(AMP SECTION)

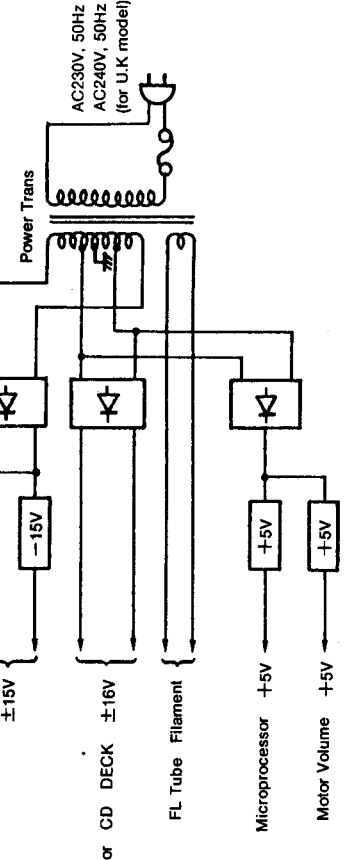
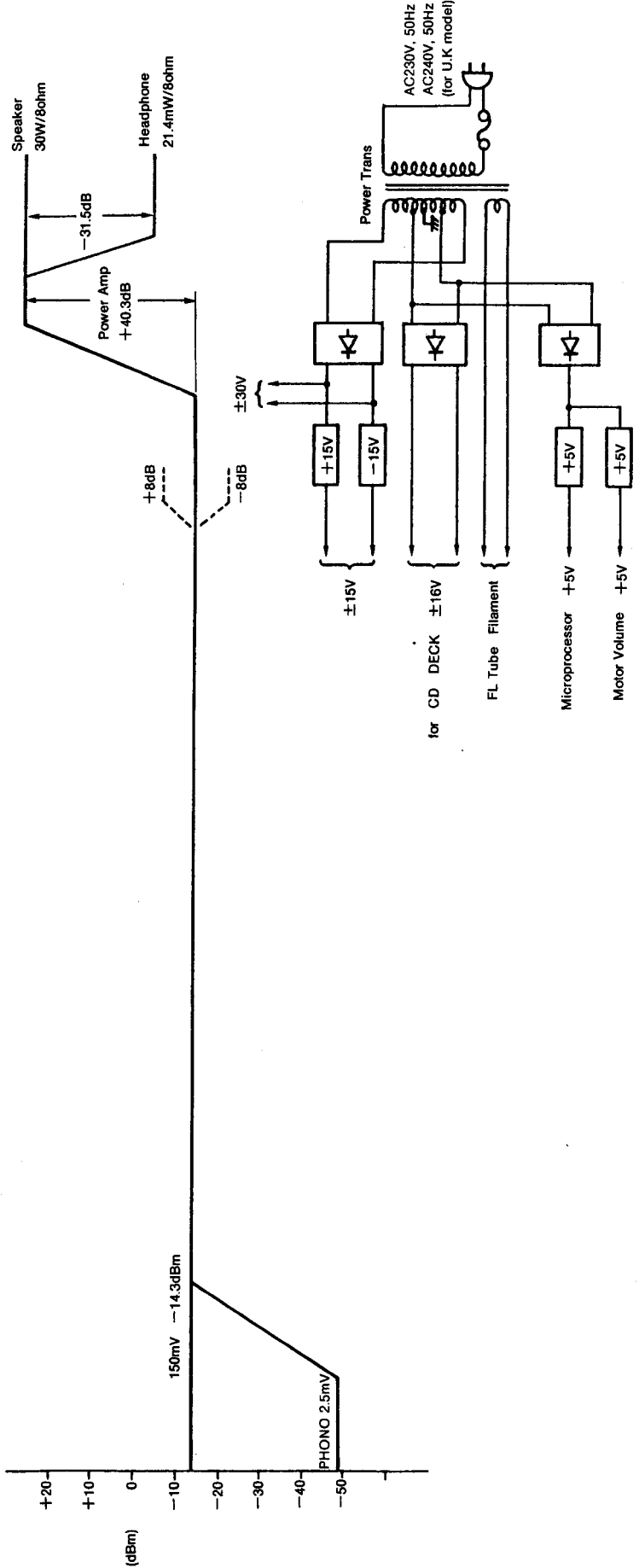
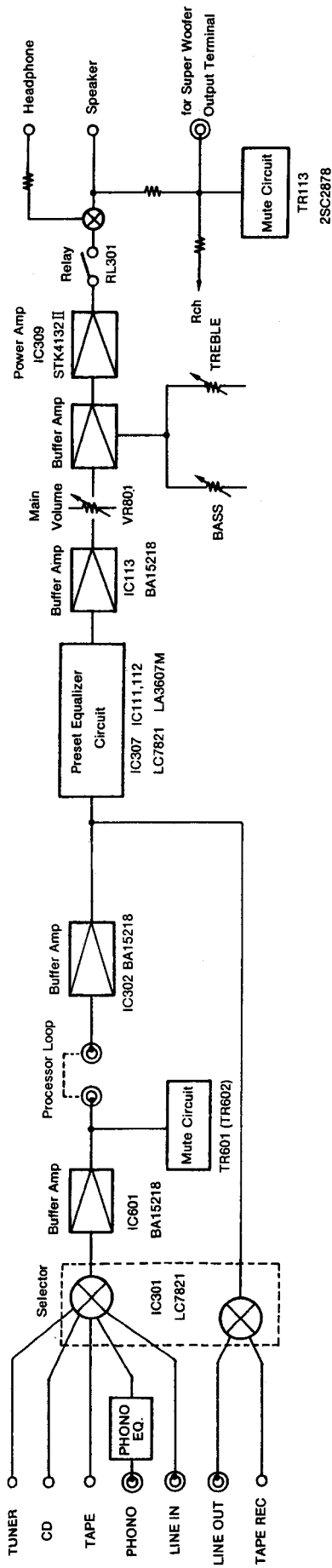

RECEIVER SECTION

ADJUSTMENTS

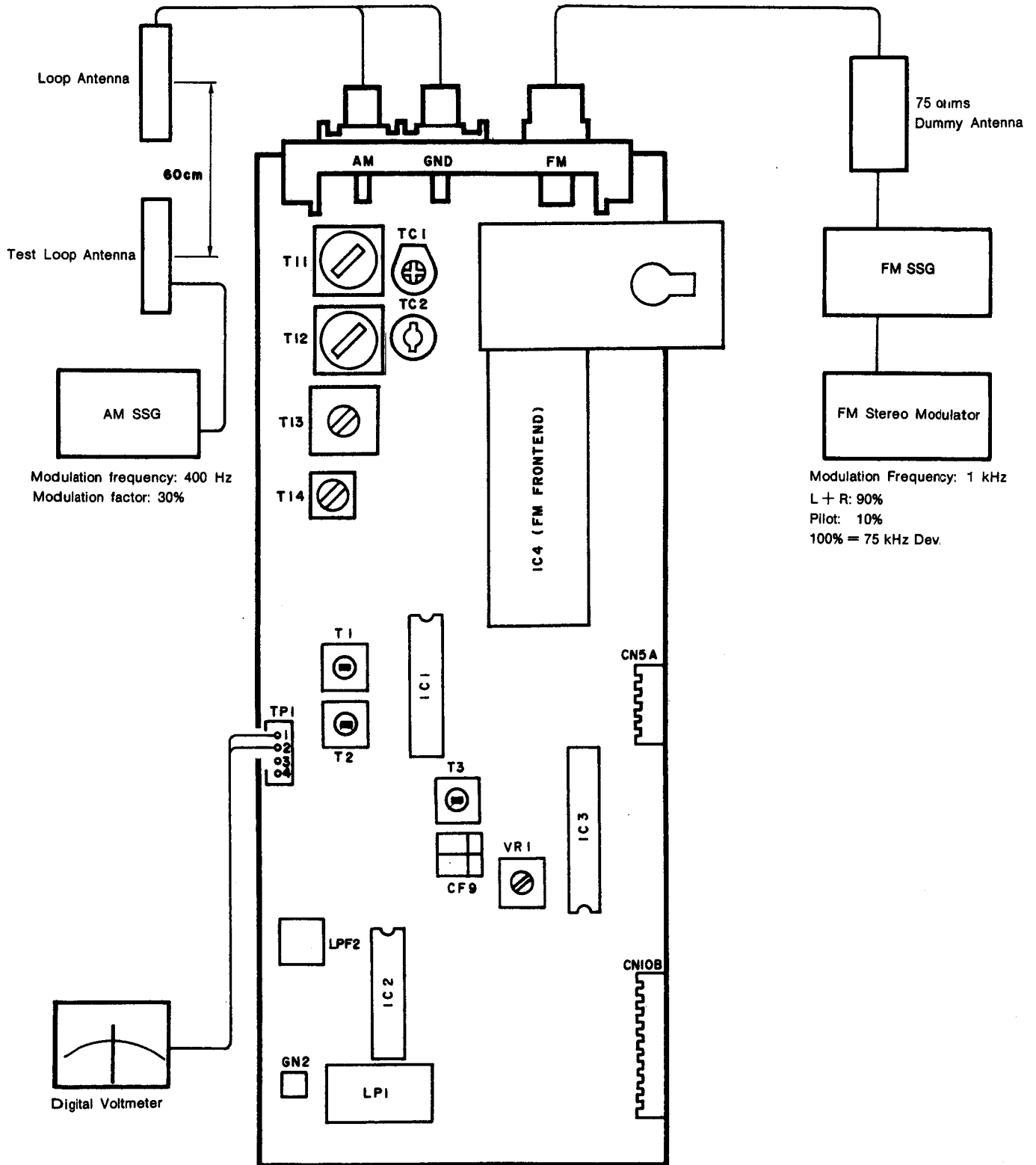

RECEIVER SECTION

KU-9258B-1 TUNER UNIT ASS'Y (Component Side)

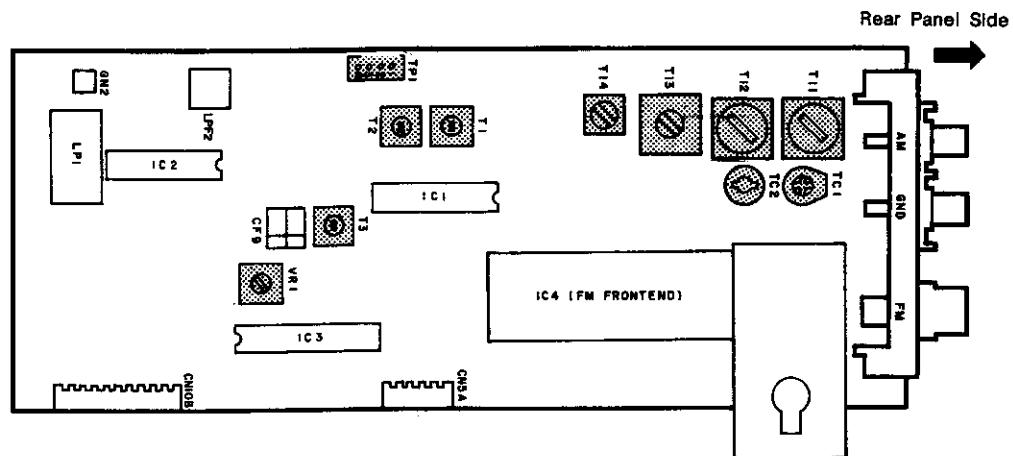

1. FM adjustment (BAND SELECTOR button: FM, STEREO / MONO MUTE button: AUTO)

Step	Adjustment item	Tuning point (Channel setting)	Input				Output		Adjustment location	Setting value	Notes	
			Measuring instrument	Frequency	Input level	Modulation	Connection location	Measuring instrument				Connection location
1	FM DC balance	98.00MHz	FM S.G.	98.00MHz	60dB μ	1kHz 75kHz DEV	FM antenna terminal	Digital voltmeter	⊕ TP-1 ① Pin ⊖ TP-1 ② Pin	T-1	0 \pm 50mV	Perform with monaural modulation signal
2	Distortion	"	"	"	"	"	"	Distortion factor meter	Output terminal	T-2	Minimum distortion	"
3 Repeat Steps 1 and 2.												
4	AUTO STOP level	98.00MHz	FM S.G.	98.00MHz	22dB μ	1kHz 75kHz DEV	FM antenna terminal	Check for the lighting of TUNED	Output terminal	VR-1	Input level 22dB μ \pm 4dB	(Level at which TUNED lights up) Level at which the output is provided

2. MW adjustment (BAND SELECT button: MW)

1	IF	Clear frequency (without a broadcast)	AM IF sweep	-	Level at which AGC is not applied	-	AM antenna terminal	Oscilloscope	⊕ TP-1 ④ Pin ⊖ TP-1 ③ Pin	T-3	Waveform maximum and symmetry	
2	Band edge	522kHz	-	-	-	-	-	Digital voltmeter	⊕ TP-⑤ Pin ⊖ G TP-1 ③ Pin	T-14	1.2V	No place to adjust
		1611kHz	-	-	-	-	-	-	-	-	Approx. 8.05V	
3	Tracking	603kHz	AM S.G.	603kHz	Level at which AGC is not applied	400Hz 30%	Loop antenna	VTVM	Output terminal	T-12	Maximum output	
4	Tracking	1404kHz	"	1404kHz	"	"	"	"	"	TC-2	Maximum output	
5 Repeat Steps 2 to 4, and set the output to maximum.												

3. LW adjustment (BAND SELECT button: LW)

1	IF	Clear frequency (without a broadcast)	AM IF sweep	-	Level at which AGC is not applied	-	AM antenna terminal	Oscilloscope	⊕ TP-1 ④ Pin ⊖ TP-1 ③ Pin	T-3	Waveform maximum and symmetry	
2	Band edge	153kHz	-	-	-	-	-	Digital voltmeter	⊕ TP-⑤ Pin ⊖ G TP-1 ③ Pin	T-13	1.2V	No place to adjust
		279kHz	-	-	-	-	-	-	-	-	Approx. 7V	
3	Tracking	163kHz	AM S.G.	163kHz	Level at which AGC is not applied	400Hz 30%	Loop antenna	VTVM	Output terminal	T-11	Maximum output	
4	Tracking	270kHz	"	270kHz	"	"	"	"	"	TC-1	Maximum output	
5 Repeat Steps 2 to 4, and set the output to maximum.												

Front End
Part number: 2160079005

No.	Name	No.	Name
1	ANT	5	Vt
2	ANT	6	+B
3	AGC	7	IF OUT
4	GND	8	OSC OUT

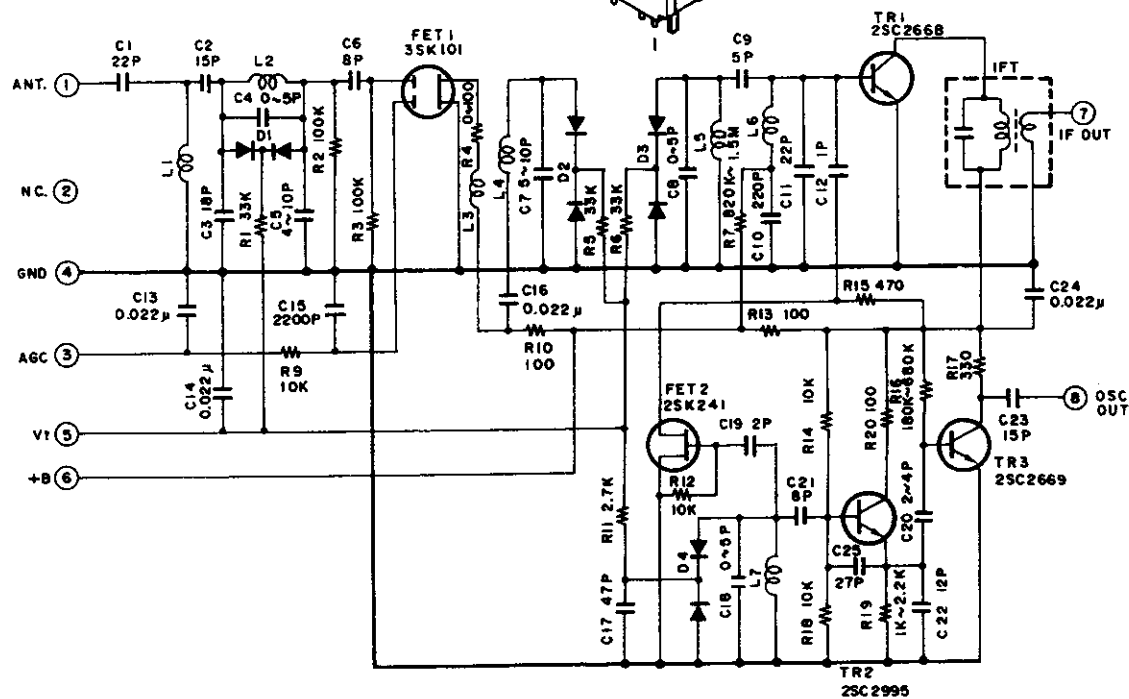
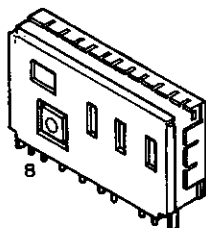

RECEIVER SECTION

SEMICONDUCTORS

IC's

LM7000 (IC003)

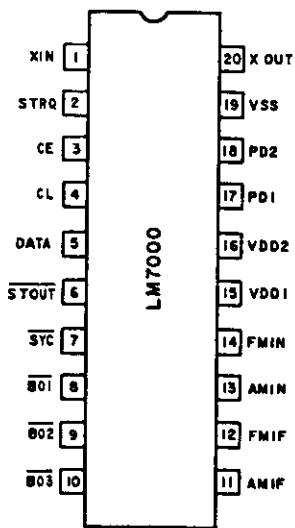
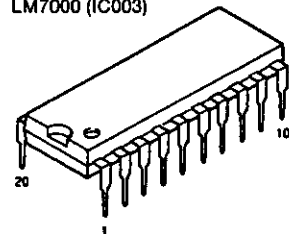

Pin Description

- SYC : Clock (400 kHz) for the controller
- XIN, XOUT : X'tal oscillator (7.2 MHz) with built-in feedback resistor
- FM IN, AM IN : Local oscillator signal input
- CE, CL, DATA : Data input
- B01, B02, B03 : Band data output. B01 can be set as the time base output (8 Hz).
- STRQ : IF counter request input
- STOUT : Auto research stop signal output
- VDD1, VDD2, VSS : Power supply (VDD2 is a back-up power supply)
- AMIF, FMIF : IF signal input
- PD1, PD2 : Charge pump output

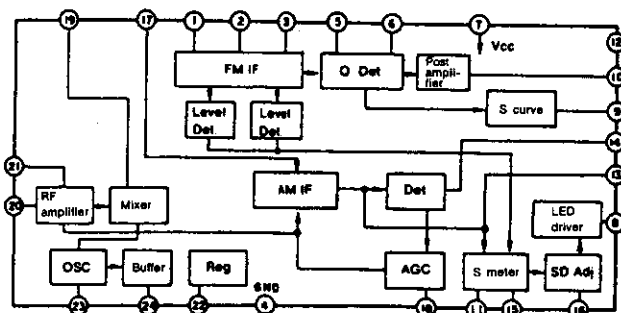

LA1267 (IC001)

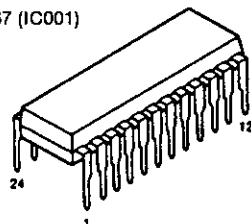

NJM78M06FA (S) (IC102)
NJM7805FA (S) (IC103)



- 1: Input
- 2: GND
- 3: Output

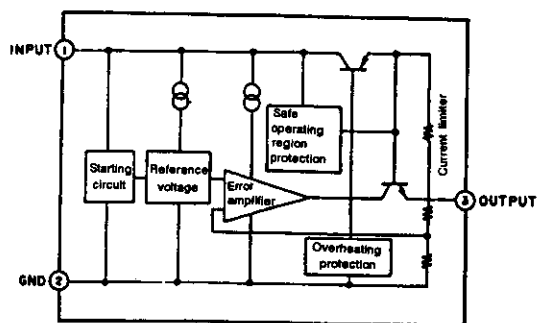

LA3410 (IC002)

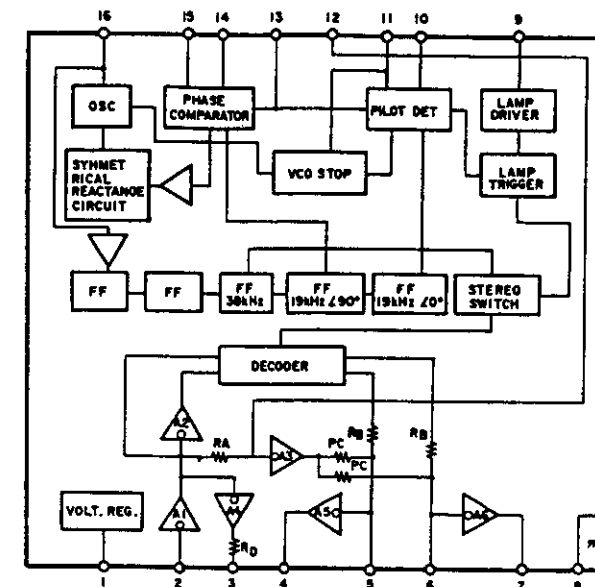
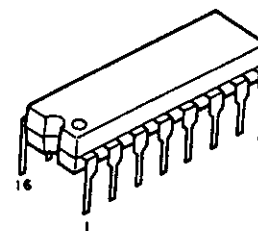

LC7821 (IC301, 307)

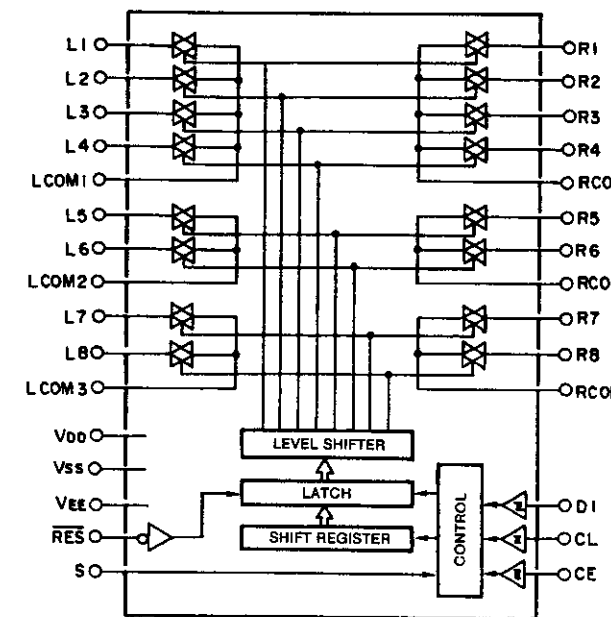
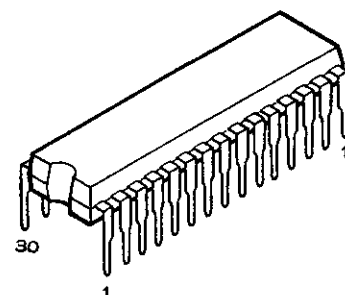

Pin Functions

Pin name	I/O	Internal equivalence circuit	Pin functions																					
V _{DD} , V _{SS} , V _{EE}			Power supply pins																					
L1~L8, R1~R8, LCOM1~LCOM4, BCOM1~RCOM4		See block diagram	Input/output pins of the analog switch																					
CL, DI, CE	I		Serial data input pins (Schmitt buffer) CL Clock input pin DI Data input pin CE Chip enable pin																					
S	I		Selection pins when two are used Setting the S pins to low and high will result in the addresses of the table below. <table border="1" style="margin-left: 20px;"> <thead> <tr> <th rowspan="2">Part name</th> <th rowspan="2">S pin</th> <th colspan="4">Address</th> </tr> <tr> <th>A₀</th> <th>A₁</th> <th>A₂</th> <th>A₃</th> </tr> </thead> <tbody> <tr> <td rowspan="3">LC7821</td> <td>L</td> <td>0</td> <td>1</td> <td>0</td> <td>1</td> </tr> <tr> <td>H</td> <td>1</td> <td>1</td> <td>0</td> <td>1</td> </tr> </tbody> </table>	Part name	S pin	Address				A ₀	A ₁	A ₂	A ₃	LC7821	L	0	1	0	1	H	1	1	0	1
Part name	S pin	Address																						
		A ₀	A ₁	A ₂	A ₃																			
LC7821	L	0	1	0	1																			
	H	1	1	0	1																			
	RES	I		Reset pin When the power is switched on the condition of the analog switches is be undetermined, but setting this pin to low level will set all analog switches off.																				

RECEIVER SECTION

LB1639 (IC801)

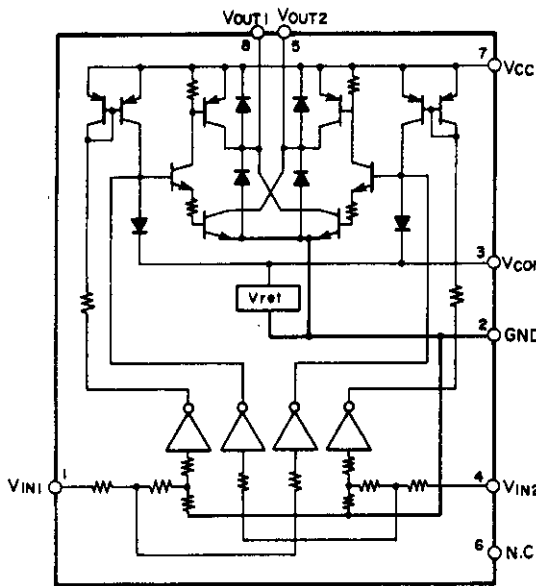
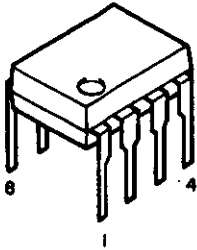

BA15218 (IC302~304,601)
NJM2068DDC (IC109,701)

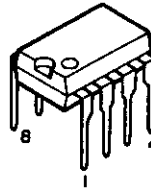

BA15218F (IC113)

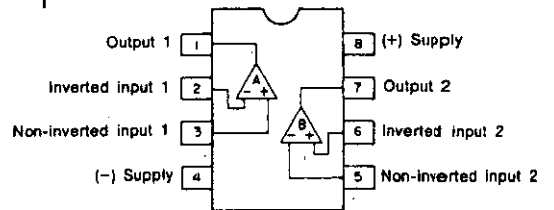
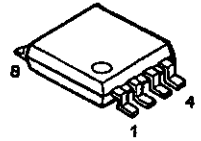

LA3607M (IC111,112)

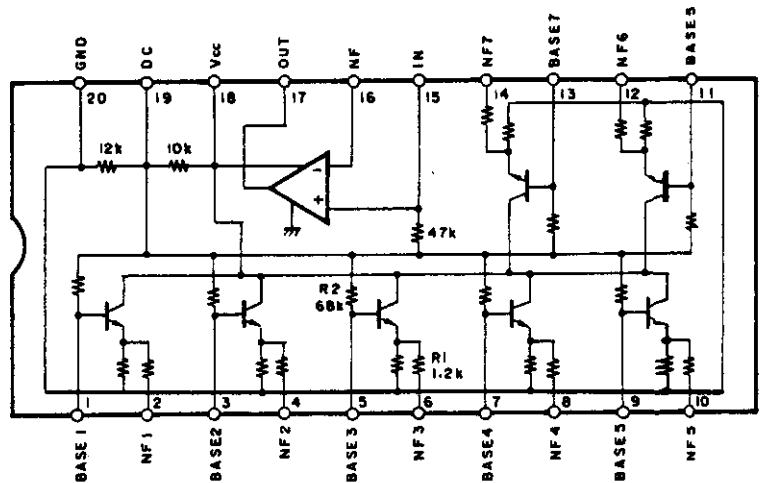
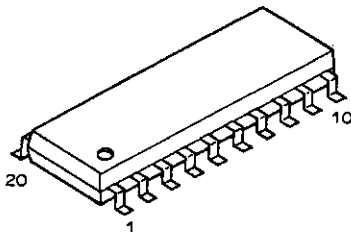

STK4152II (IC309)

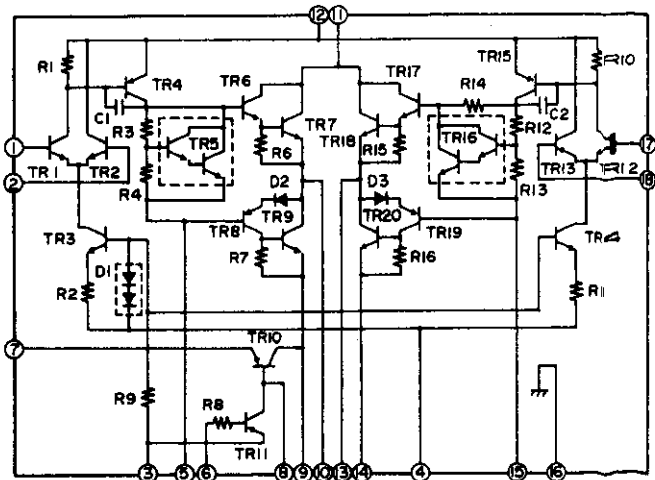
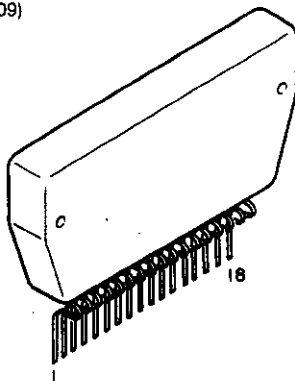

RECEIVER SECTION

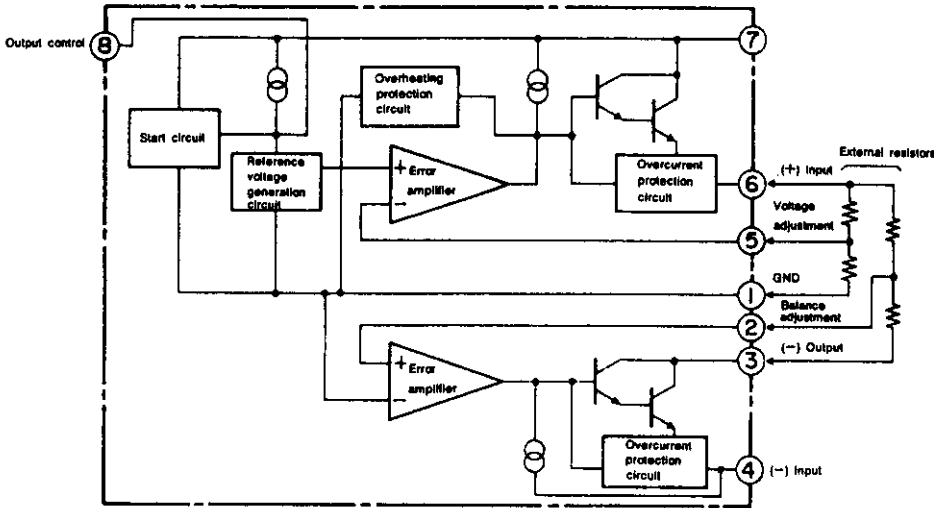

M5230L (IC101)

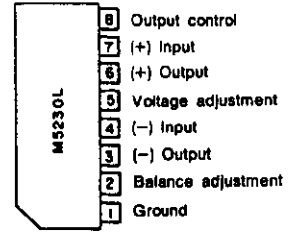
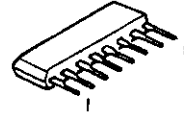

● Transistors

2SA988 (E/F)
2SC461 (C)
2SC2878 (A/B)

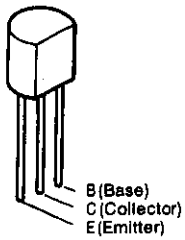

2SB647A (C)

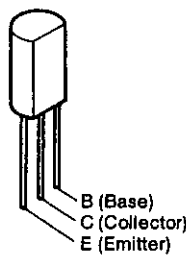

2SC1740S (E)
2SC2458 (BL)
2SA1048 (GR)

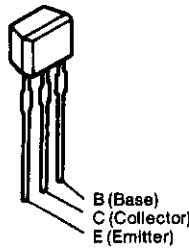

(FET)
2SK365 (BL/GR)

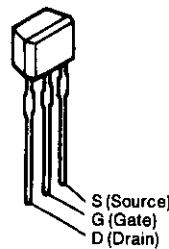

2SA1488 (Y/GR)
2SC3851 (Y/GR)

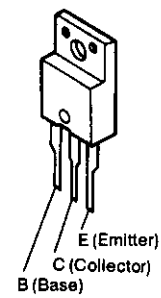

DTA144ES ... PNP Type
DTC114ES } NPN Type
DTC144ES
RN1241 (A/B)

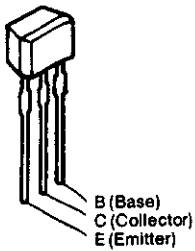

DTA144EK PNP Type

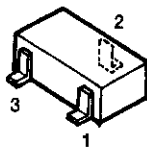

1: GND / Emitter
2: In / Base
3: Out / Collector

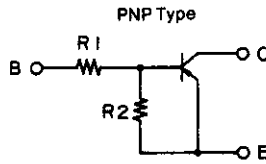

	R1	R2
DTA144EK	47k ohm	47k ohm
DTA144ES	47k ohm	47k ohm

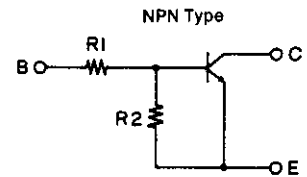

	R1	R2
DTC114ES	10k ohm	1.0k ohm
DTC144ES	47k ohm	4.7k ohm
RN1241(A/B)	5.6k ohm	—

(FET)
2SK381 (B)/(C)

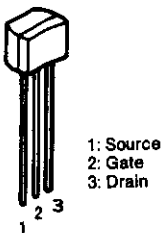

1: Source
2: Gate
3: Drain

2SB1328 (P)

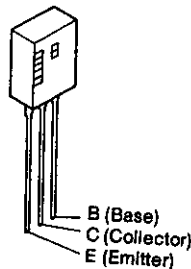

(FET)
2SK161 (GR)

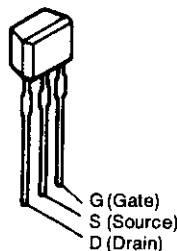

RECEIVER SECTION

● Diodes (including LED)

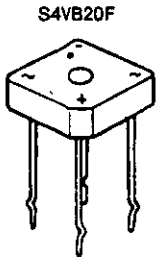
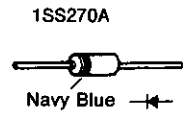
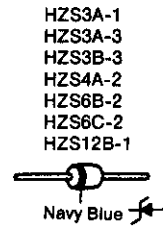
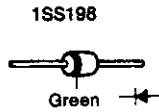
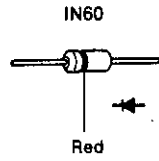
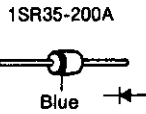

SLR-37MG (Green)
SLR-37VR (Red)

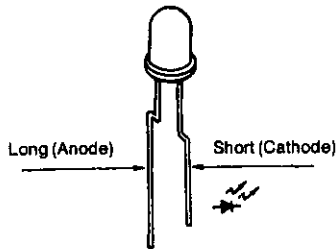

SVC321SPA-D-2
(Varactor)

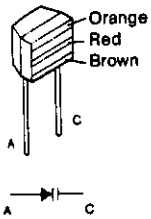

● Infrared Remote Control Sensor

SBX1610-52

Part No.: 499 0150 008

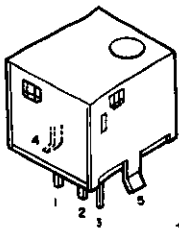

- 1. Vcc
- 2. Output
- 3. GND
- 4. Case fin
- 5. Case fin

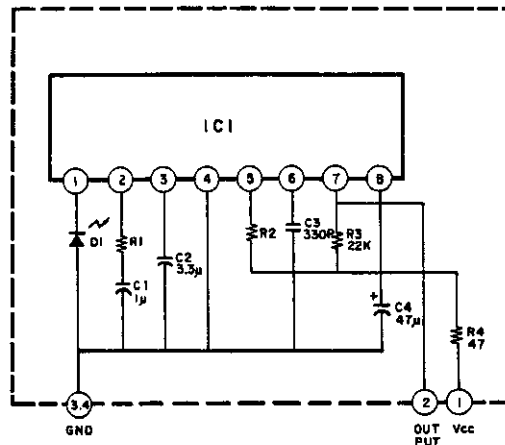

- IC1: CX20106A chip
- D1: PIN photodiode chip
- C1, C2, C4: Aluminum electrolytic capacitor
- C3: Ceramic SL characteristic, ±5%
- R1: Carbon film resistor for a adjustment
- R2: Carbon film resistor for b adjustment (Use ±1%)
- R (other than above): ±5%

* This unit is wholly used in the receiver section.

MICROPROCESSOR DOCUMENTATION

HD404719A16FS Part No.: 262 1571 204

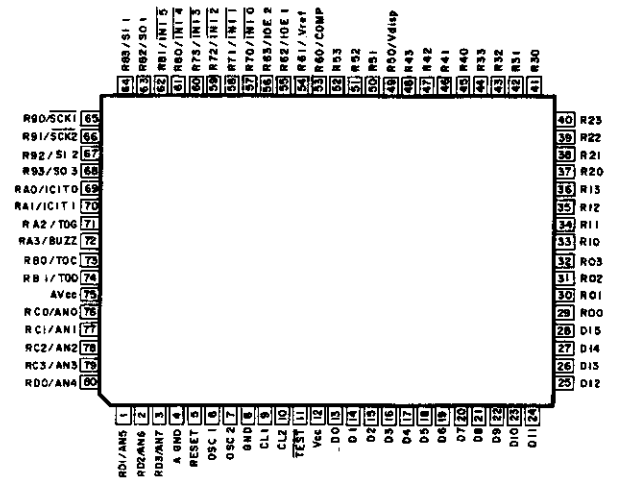
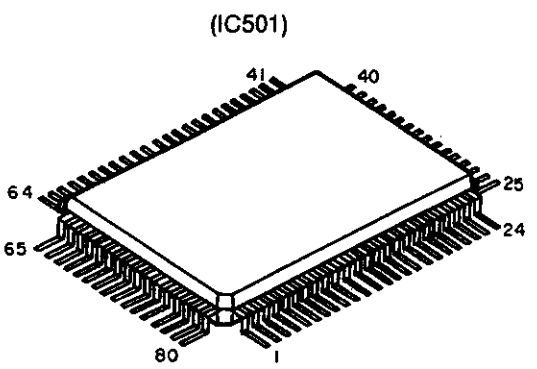

1. Overview

The functions of this microcomputer are made up of the following four pillars.

- a. Tuner functions
 - These functions perform the required control for the reception of FM and AM broadcasts.
- b. Auto Functions
 - Positioned at the heart of the system stereo, the auto functions perform serial communications with other components (such as the deck, CD, and amplifier) to provide overall control.
 - These functions decode the signals from the remote control and send them to each component of the system.
- c. Timer functions
 - Counts the clock of the 24-hour display.
- d. CD Display functions
 - Provides the CD operation displays.

Note 1: When buttons "ENTER/NEXT" and "MEMORY" of the wiring diagram are pressed simultaneously and the power cord is inserted into the power outlet, the frequencies used for the tracking adjustment will automatically be registered in the preset memory as indicated below.
Use this information for tuning and other procedures.

	P 1	P 2	P 3	P 4	P 5	P 6	P 7	P 8	P 9	P 10
MW	522	603	999	1098	1404	1611	153	163	270	279
LW										
	P 11	P 12	P 13	P 14	P 15	P 16	P 17	P 18	P 19	P 20
FM (MHz)	87.50	89.00	98.00	100.10	108.00	87.50	254	87.50	87.50	87.50
	P 21	P 22	P 23	P 24	P 25	P 26	P 27	P 28	P 29	P 30
AM (kHz)	522	522	522	522	522	522	522	522	522	522

2. Receiving Band Table

Band	Receiving frequency	Local oscillator frequency	IF frequency	Frequency division ratio	Comparison frequency	Step frequency	Other
FM	87.50~108.00 MHz	98.20~118.70 MHz	10.7 MHz	1/2	25 kHz	100 kHz	STEREO
MW	522~1611 kHz	972~2061 kHz	450 kHz	—	9 kHz	9 kHz	
LW	153~279 kHz	603~729 kHz	450 kHz	—	1 kHz	1 kHz	

3. Block Diagram

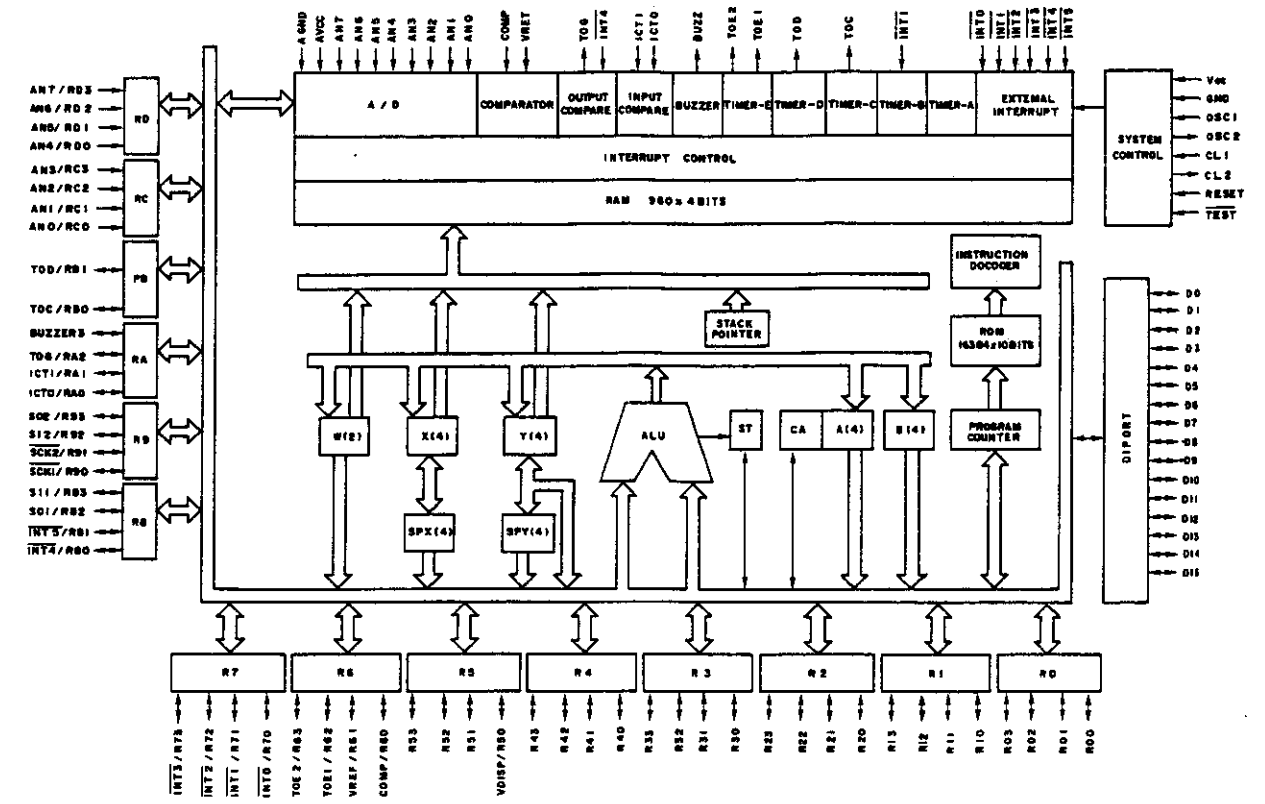

RECEIVER SECTION

4. IC HD404719A16FS Pin Description (See the Peripheral Wiring Diagram of Page 43.)

PIN NO.	Port Name	I/O	I	A	Function Name	U/D	Function
1	RD1/AN5	I	L	H	KR1	D	KEY RETURN pulse input pin.
2	RD2/AN6	I	L	H	KR2	D	KEY RETURN pulse input pin.
3	RD3/AN7	I	L	H	KR3	D	KEY RETURN pulse input pin.
4	AGND	-	-	-		-	Analog ground pin. Connect to ground.
5	RESET	I	L		RESET	D	System reset input pin of the microprocessor.
6	OSC1	I				-	System clock input pin of the microprocessor. (f=4 MHz)
7	OSC2	O				-	System clock output pin of the microprocessor. (f=4 MHz)
8	GND	-	-	-		-	Ground pin.
9	CL1	I				-	Input pin for the clock. (f=32.768 kHz)
10	CL2	O				-	Output pin for the clock. (f=32.768 kHz)
11	TEST	I				U	Connect to Vcc (pin 12).
12	Vcc	-	-	-		-	5 V power supply pin. (Back up)
13-28	D0-D15	O	L		T15-T0	(D)	Digit output pins for fluorescent tube drive.
29-32	R00-R03	O	L		t-p	(D)	Segment output pins for fluorescent tube drive.
33-36	R10-R13	O	L		n-j	(D)	Segment output pins for fluorescent tube drive.
37-40	R20-R23	O	L		h-e	(D)	Segment output pins for fluorescent tube drive.
41-44	R30-R33	O	L		d-a	(D)	Segment output pins for fluorescent tube drive.
45	R40	O	L		S.CLOCK	D	Serial clock output pin for the LC7821.
46	R41	O	L		S.DATA	D	Serial data output pin for the LC7821.
47	R42	O	L		S.CE	D	CE output pin for the LC7821.
48	R43	O	L	L	S.FUNC MUTE	D	This pin outputs the muting output when FUNCTION or TONE changes.
49	R50/Vdisp	I	-	-	Vdisp	-	Connect to -30V. This pin is for the mask option.
50	R51	I	-	-	NC	U	
51	R52	I	-	-	NC	U	
52	R53	I	H		REMOCON IN2	U	Remote control 2 input pin for room to room.
53	R60/COMP	O	H	L	POWER OFF	D	Control output pin at the time of POWER ON/OFF.
54	R61/Vref	O	H	L	RELAY	U	This output pin performs a toggle operation in synchronization with the POWER button and drives a relay which switches on and off the power of other equipment.
55	R62/TOE1	O	H	L	VOLUME DOWN	U	Output pin for the motor-drive volume control. Down is low level.
56	R63/TOE2	O	H	L	VOLUME UP	U	Output pin for the motor-drive volume control. Up is low level.
57	R70/INT0	I	H		SERIAL SIG IN	U	Input pin for serial communications.
58	R71/INT1	I	H		50/60 IN	U	50/60 Hz half wave rectified pulse input pin.
59	R72/INT2	I	H		REMOCON IN1	U	Input pin for remote control 1.
60	R73/INT3	I	H		SCK	U	Clock input pin for the CD display data.
61	R80/INT4	I	L	H	PROTECT IN	D	Input pin for switching the SP relay off for 4 seconds.
62	R81/INT5	O	H		SERIAL SIG OUT	U	Output pin for serial communications.
63	R82/SO1	O	H		S01	U	Data output pin for the CD display data.
64	R83/SI1	I	H		SI1	U	Data input pin for the CD display data.

PIN NO.	Port Name	I/O	I	A	Function Name	U/D	Function
65	R90/SCK1	O	L	H	KARAOKE	D	Outputs a high-level signal when the PRESET TONE is KARAOKE.
66	R91/SCK2	O	L		CLOCK	U	Clock output pin for the serial data when the data is sent to the programmable divider.
67	R92/SI2	O	L		ST.REQ	U	This output pin makes a request that the IF count operation to the programmable divider be started when, during auto tuning, a signal from the vicinity of the station is input from the detection IC.
68	R93/SO2	O	L		DATA	U	Serial data output pin for sending data to the programmable divider of the PLL IC.
69	RA0/ICT0	O	L		CE	U	This output pin is set to high level when sending data to the programmable divider, then returned to low level when the data transmission is completed in order to latch the register.
70	RA1/ICT1	O	L	L	MUTE	U	Control signal output pin for applying muting to the audio output of the tuner.
71	RA2/TOG	O	L	H	AUTO/MONO	D	Control signal output pin for the monaural/stereo switching pins of the FM MPX IC.
72	RA3/BUZZ	O	H		SCI ENABLE	U	ENABLE clock output pin for the CD display data.
73	RB0/TOC	O	L		CLOCK32K	U	Adjustment pin of the crystal. (4 Hz)
74	RB1/TOD	O	L	H	CD ON/OFF	D	Controls the power of the CD when the function is CD. High level when CD is selected.
75	AVCC	I	-	-			Connect to Vcc.
76	RCO/ANO	I	H	L	STOP IN	U	This input pin takes in the signal which is output from the programmable divider when the station has been tuned during auto tuning (i.e., when the IF count has reached the specified value).
77	RC1/AN1	I	H	L	STEREO IN	U	Input pin used for taking in the stereo display signal from the FM MPX IC and displaying it on the fluorescent tube.
78	RC2/AN2	I	H	L	TUNED IN	U	This pin takes in the signal when the synchronous circuit has been properly tuned. Low level when tuned.
79	RC3/AN3	I	H	L	SIGNAL IN	U	Input pin for detecting that a station is in the vicinity during auto tuning. (Active low)
80	RD0/AN4	I	H	L	KR0	D	KEY RETURN pulse input pin.

I/O Input/Output
I At time of initialization
A When active
U/D Pull Up/Pull Down

RECEIVER SECTION

MICROPROCESSOR PERIPHERAL WIRING DIAGRAM

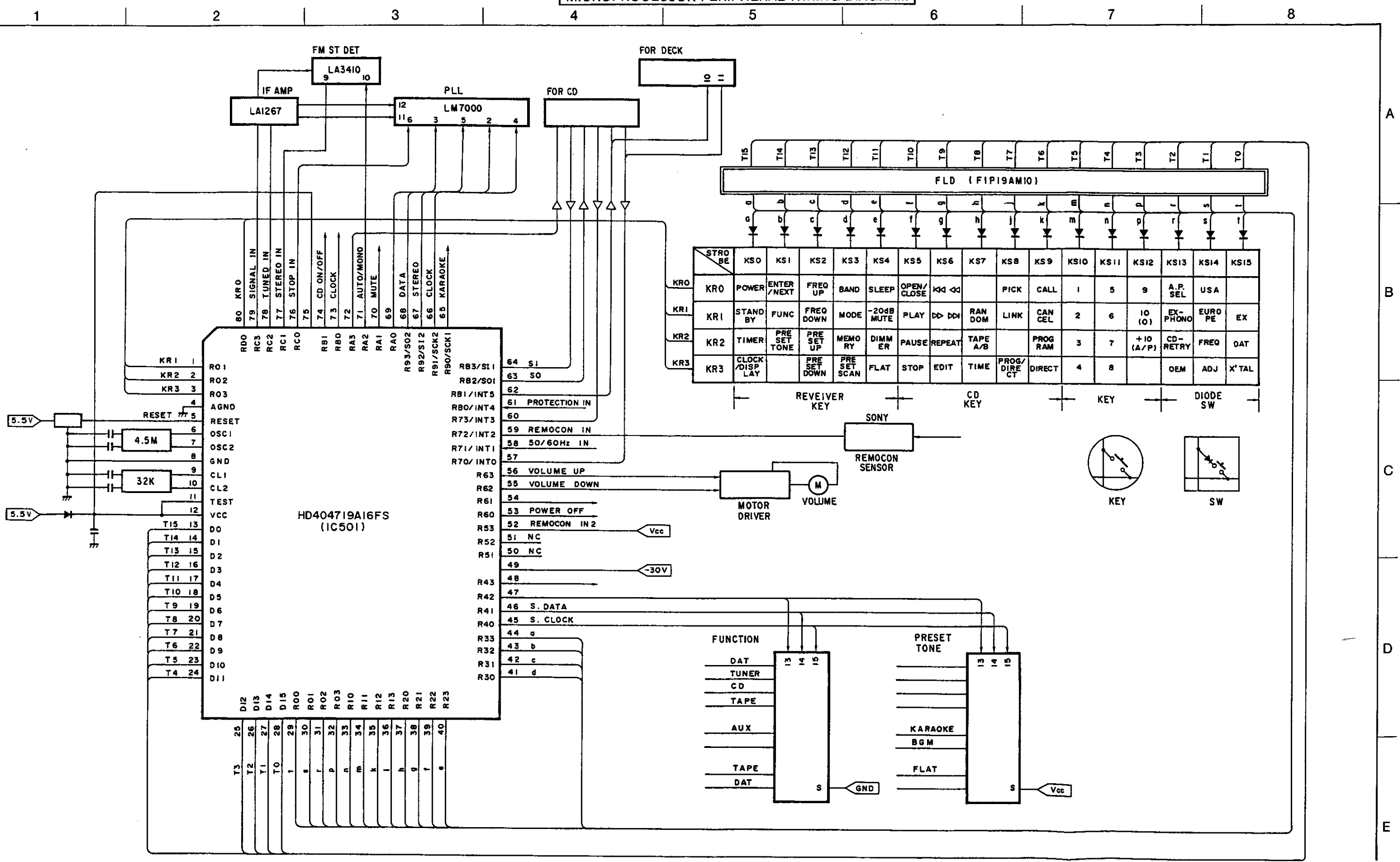

A
B
C
D
E

RECEIVER SECTION

WIRING DIAGRAM

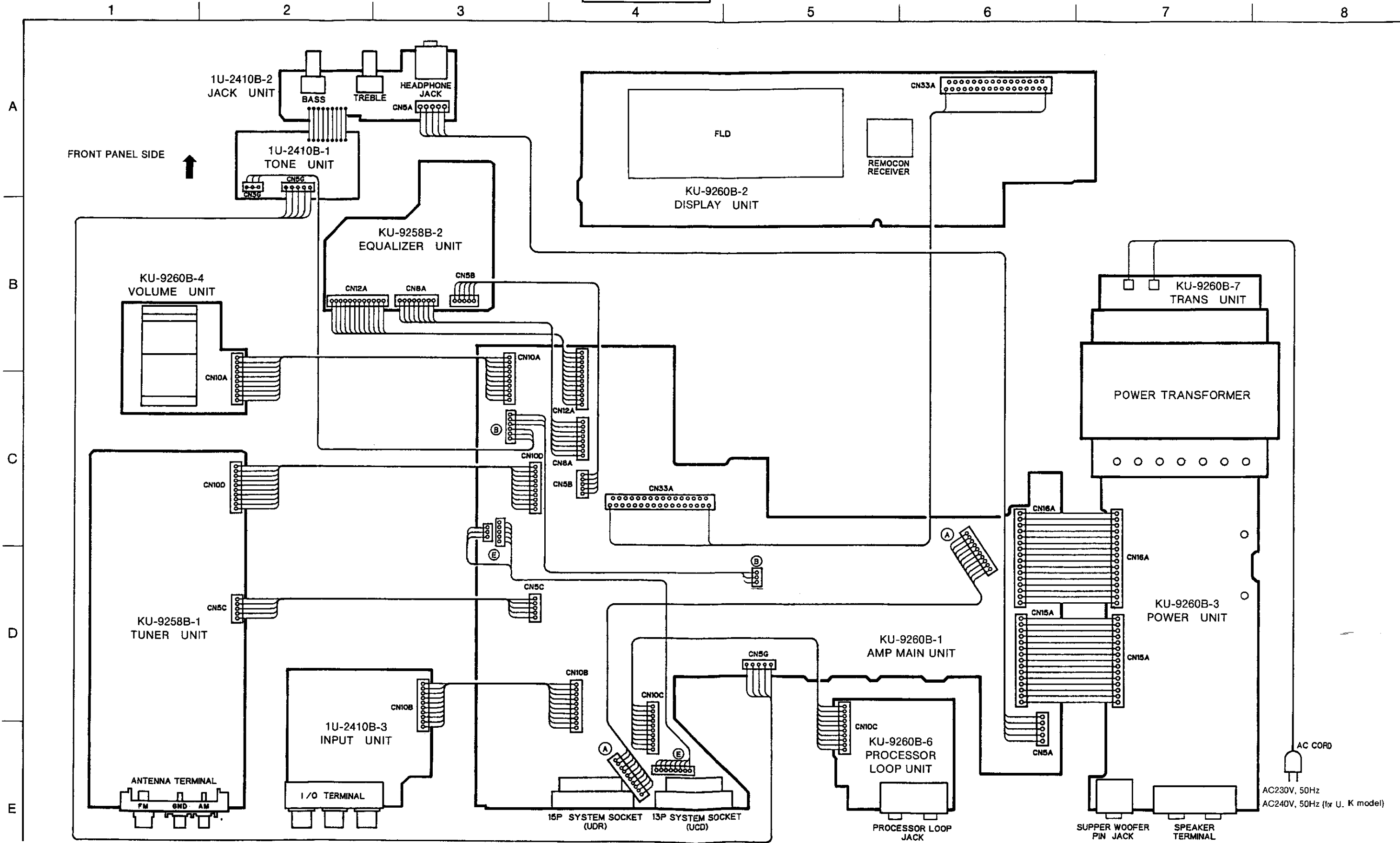

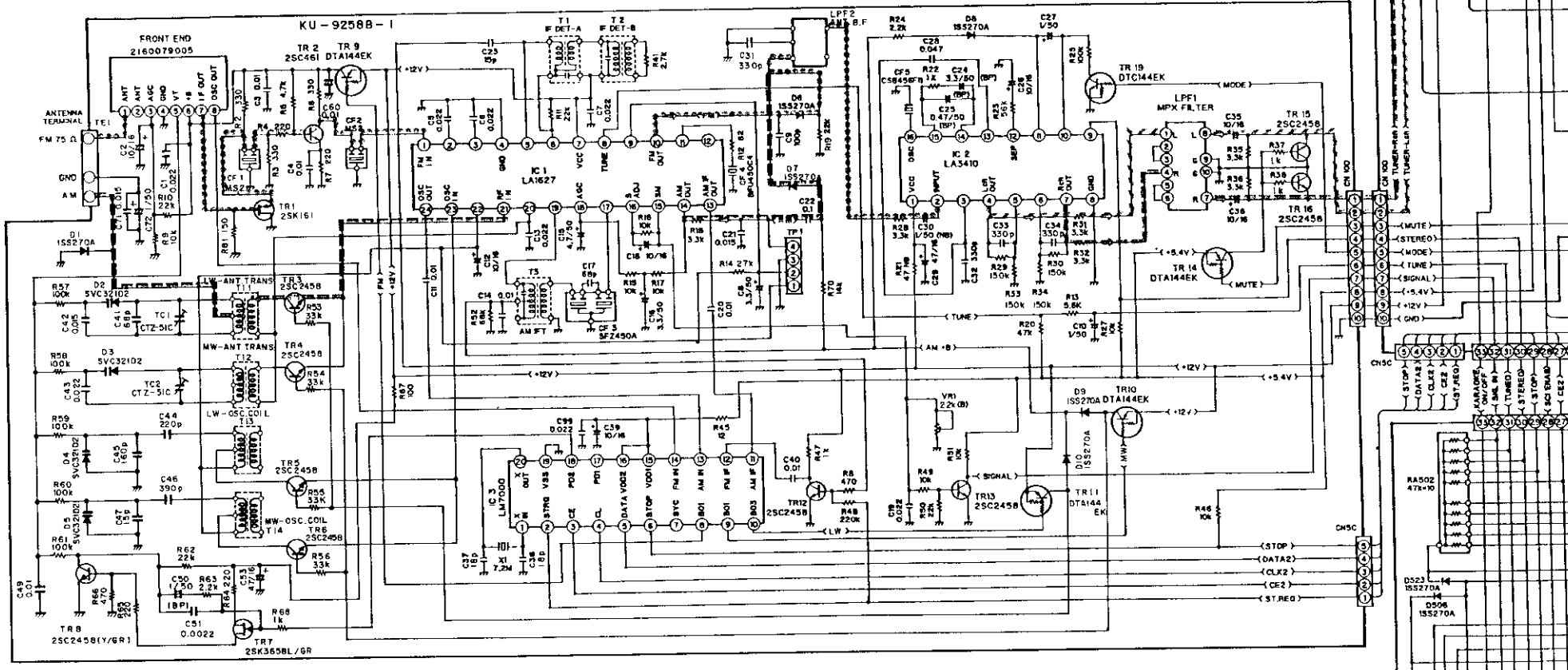
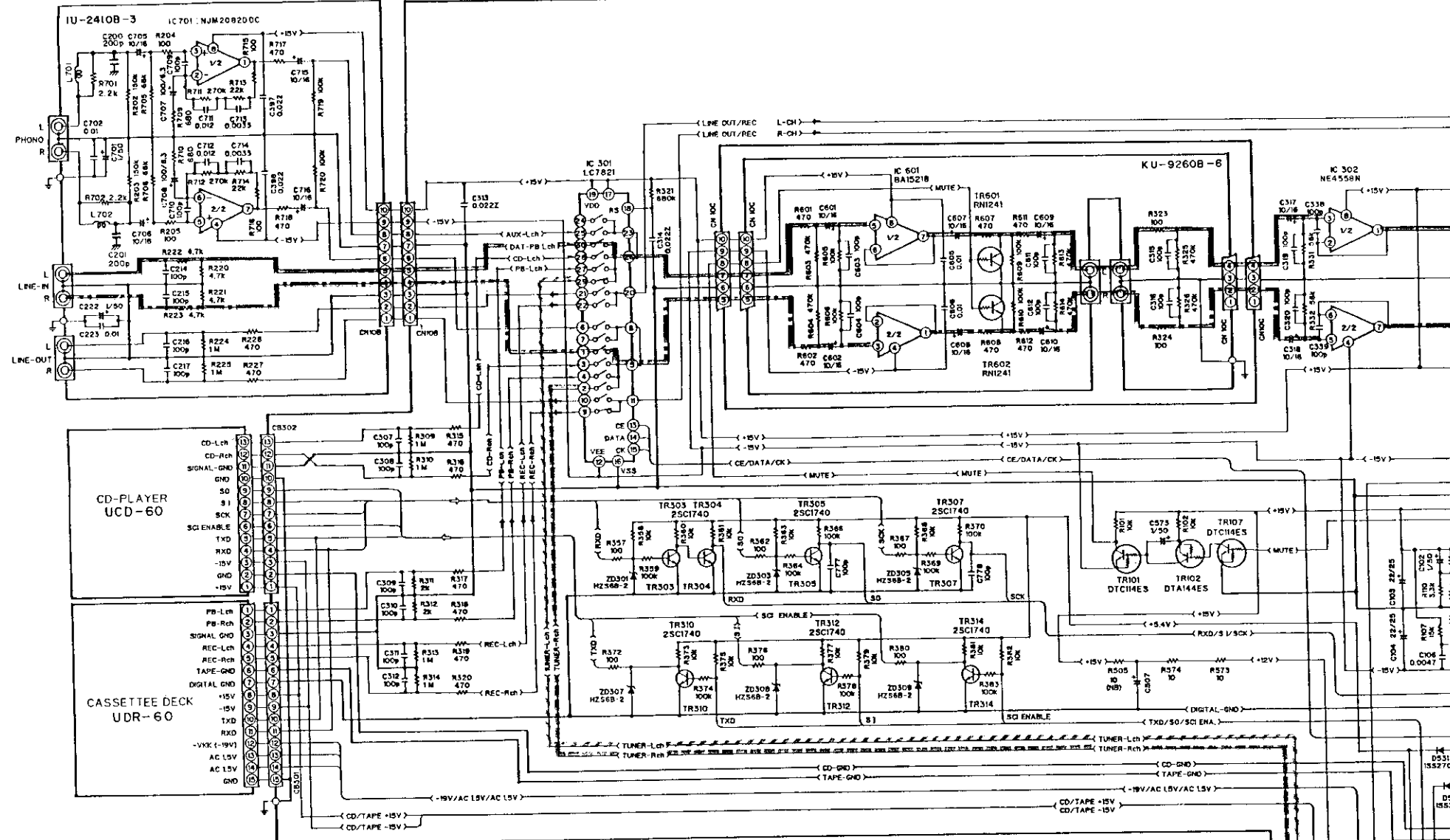

- FM, MW Lch SIGNAL LINE
- FM, MW Rch SIGNAL LINE
- FM SIGNAL LINE
- AM (LW) SIGNAL LINE
- Lch SIGNAL LINE
- Rch SIGNAL LINE

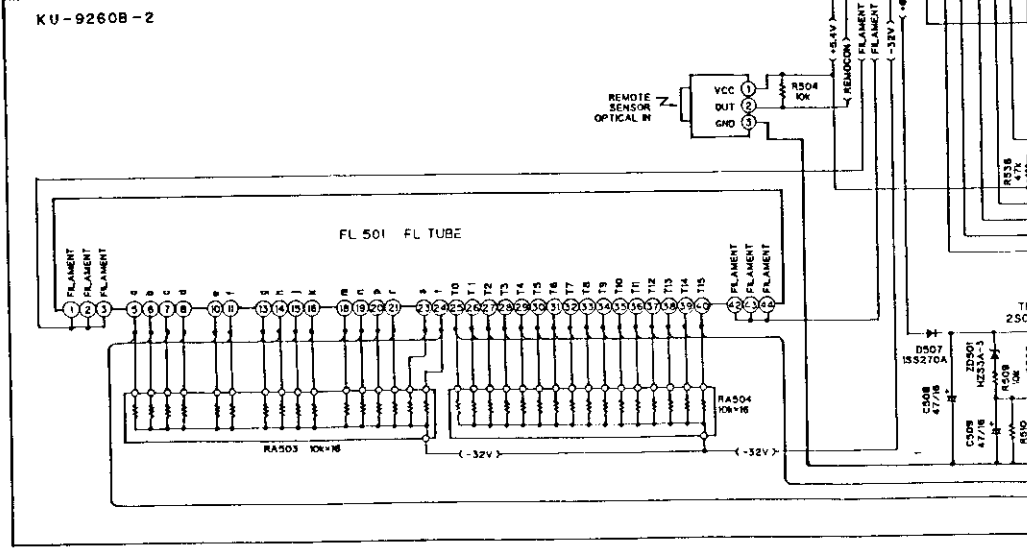

WARNING:
Parts marked with this symbol \triangle have critical characteristics. Use ONLY replacement parts recommended by the manufacturer.

CAUTION:
Before returning the defective current ex...
leakage current ex...
defective.

WARNING
DO NOT return the

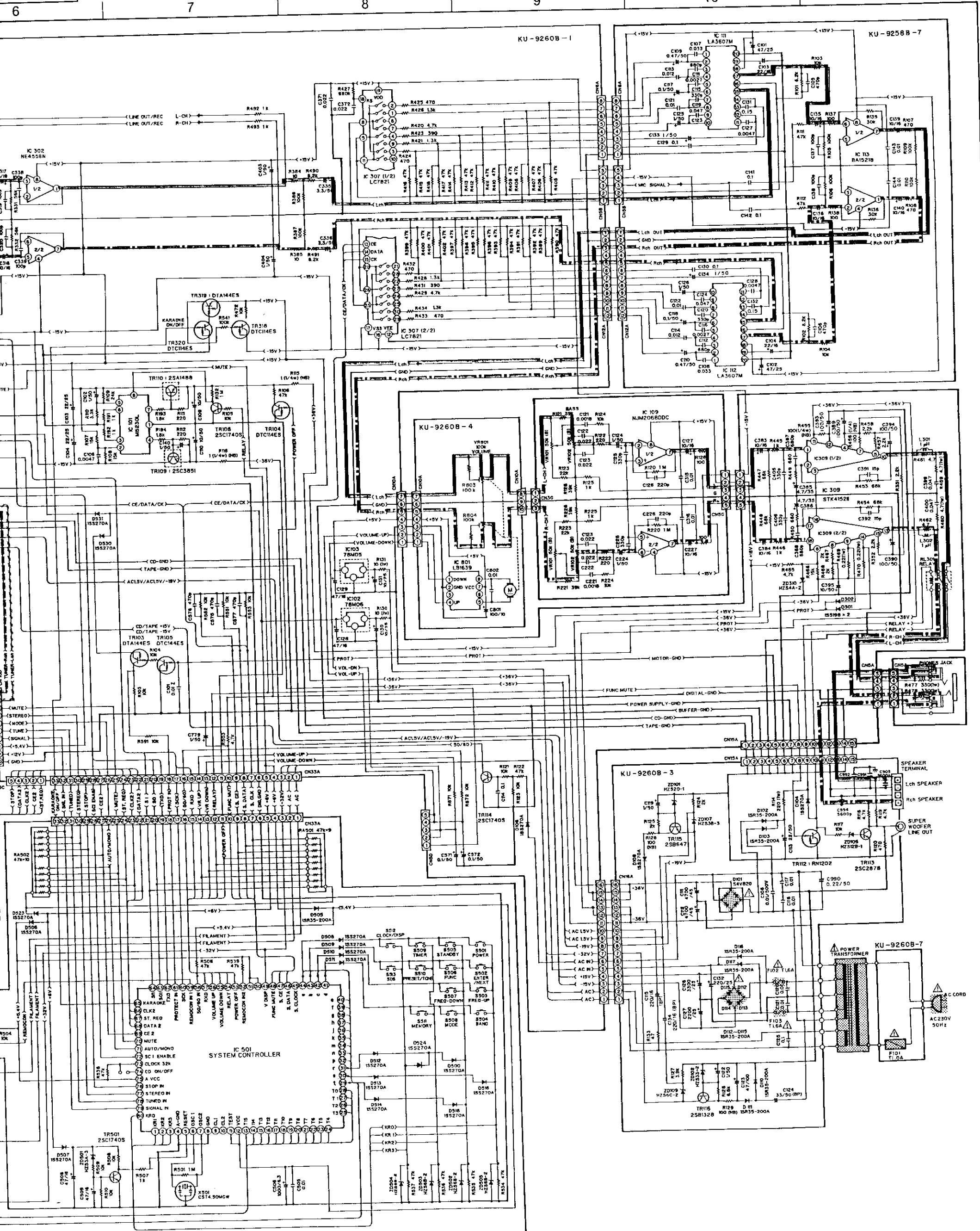

CAUTION:
Before returning the unit to the customer, make sure you make either (1) a leakage current check or (2) a line to chassis resistance check. If the leakage current exceeds 0.5 milliamps, or if the resistance from chassis to either side of the power cord is less than 240 kohms, the unit is defective.

WARNING
DO NOT return the unit to the customer until the problem is located and corrected.

NOTES
ALL RESISTANCE VALUES IN OHM K=1,000 OHM M=1,000,000 OHM
ALL CAPACITANCE VALUES IN MICRO FARAD P=MICRO-MICRO FARAD
EACH VOLTAGE AND CURRENT ARE MEASURED AT NO SIGNAL INPUT CONDITION.
CIRCUIT AND PARTS ARE SUBJECT TO CHANGE WITHOUT PRIOR NOTICE.

A
B
C
D
E
F
G

RECEIVER SECTION

PARTS LIST OF UDRA-60 EXPLODED VIEW

Ref. No.	Part No.	Part Name	Remarks	Q'ty
1	411 1158 232	Chassis		1
2	124 0079 007	Felt Sheet		2
3	417 0455 112	Radiator		1
4	412 3471 305	Trans Bracket		1
5	415 9016 019	P.C.B Holder		4
6	412 3470 005	Spring Plate		1
7	233 5947 001	Power Trans.		1
8	461 0723 003	Cushion		1
9	146 1349 215	Front Panel		1
10	143 0784 102	Window		1
11	113 1505 101	Timer Knob		1
12	113 1506 100	Function Knob		1
13	009 0066 009	33P FF Cable		1
14	412 3553 003	Tone Vol. Bracket		1
15	461 0722 004	Rubber Sheet		1
16	445 0056 008	Cord Bush		1
17	206 2073 002	AC Cord		1
18	415 0546 088	UL Tube (3.3) Black		1
19	-	-		-
20	105 1021 228	Rear Panel		1
21	205 0752 005	Short Pin		2
22	104 0258 002	Foot Ass'y		2
23	112 0707 101	Main VR Knob Ass'y		1
24	112 0708 100	Mic VR Knob		2
25	102 0508 028	Top Cover		1
26	414 9126 003	Shield Case		1
27	414 9127 002	Shield Bracket		1
28	414 9128 001	Shield Cover		1
31	KU- 9260 B-1	Amp Unit		1
32	KU- 9260 B-3	Power Unit		1
33	-	-		-
34	KU- 9260 B-2	Display Unit		1
35	1U- 2410 B1	Tone Unit		1
36	KU- 9260 B-4	Master Vol. Unit		1
37	KU- 9260 B-6	Processor Loop Unit		1
38	1U- 2410 B-3	Input Unit		1
39	KU- 9258 B-3	Tuner Unit		1
40	461 0723 045	Cushion		1
41	473 7500 044	Tapping Screw (P) 3X8	Black	10
42	473 7026 007	Tapping Screw (S) 4X6	Black	8
43	473 7002 021	Tapping Screw (S) 3X8	Black	11
44	473 8007 038	Cup Screw 3X14		2
45	473 8007 025	Cup Screw 3X8		2
46	473 7015 018	Tapping Screw (S) 3X8	Black	4
47	477 0064 107	Fixing Screw		6
48	477 0276 018	Earth Screw		1
51	216 9009 005	FM Front End	KU-9258B-1	1
52	205 0603 002	3P Ant. Terminal (DIN)	KU-9258B-1	1
53	204 8278 009	6P Pin Jack (S-GND)	1U-2410B-3	1
54	204 8266 008	4P Pin Jack (S-GND)	KU-9260B-6	1
55	204 8284 022	15P System Socket	KU-9260B-1	1
56	204 0730 056	13P System Socket (BU)	KU-9260B-1	1
57	265 0073 003	IS STK4152 II	KU-9260B-1	1
58	214 0154 005	Relay (VB24SMBU)	KU-9260B-1	1
59	393 4133 008	FLD (FIPI9AM10)	KU-9260B-2	1
60	499 0150 008	Regulator Receiver SBX 1610-52	KU-9260B-2	1
61	211 0749 107	Variable Resistor 100k ohm	KU-9260B-4 VR801	1
62	211 0766 009	Variable Resistor 50k ohm	1U-2410B	2
63	1U- 2410 B-2	Tone Vol. Unit	1U-2410B	1
64	204 8370 004	Head Phone Jack (D: 3.6)	1U-2410B	1
65	205 0592 029	4P Push Terminal	KU-9260B-3	1
66	-	-		-
67	KU- 9260 B	Trans AC Unit		1
68	KU- 9258 B-2	EQ. Unit		1
69	205 0736 005	33P FFC Base	KU-9260B-1	1
70	206 1015 029	Fuse 1.6AT	F101	1
71	206 1015 058	Fuse 1.6AT	F102 103	2
72	461 0723 029	Cushion		1
73	203 0288 052	1P Contact Ass'y		1
74	205 0071 016	Terminal Ass'y		1
75	477 0018 001	Washer (P-87)		1
76	204 8406 004	1P Pin Jack	KU-9260B-3	1
77	-	-		-
78	-	-		-
79	445 0033 005	Wire Clamp Base		4
80	GEN 7458	3T Lug Sub Ass'y		15
81	009 9033 004	1P Wire Ass'y		15
LABELS				
91	-	-		-
92	-	-		-
93	513 1581 008	Serial No. Sheet		1
94	-	-		-
PACKING & ACCESSORIES (Not included EXPLODED VIEW)				
101	505 0241 005	Cabinet Cover		1
102	-	-		-
103	503 1038 004	Cushion		1
104	-	-		-

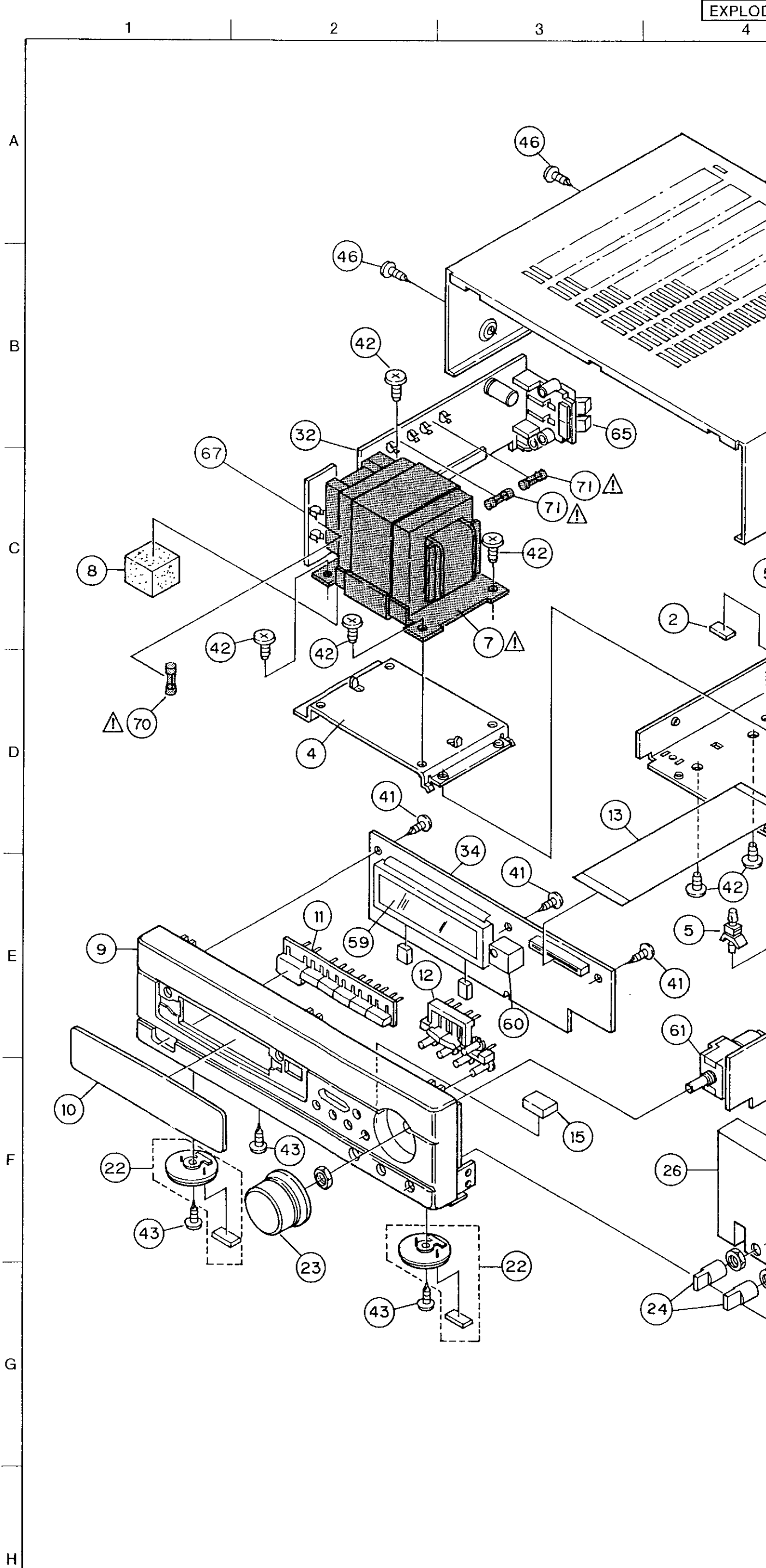

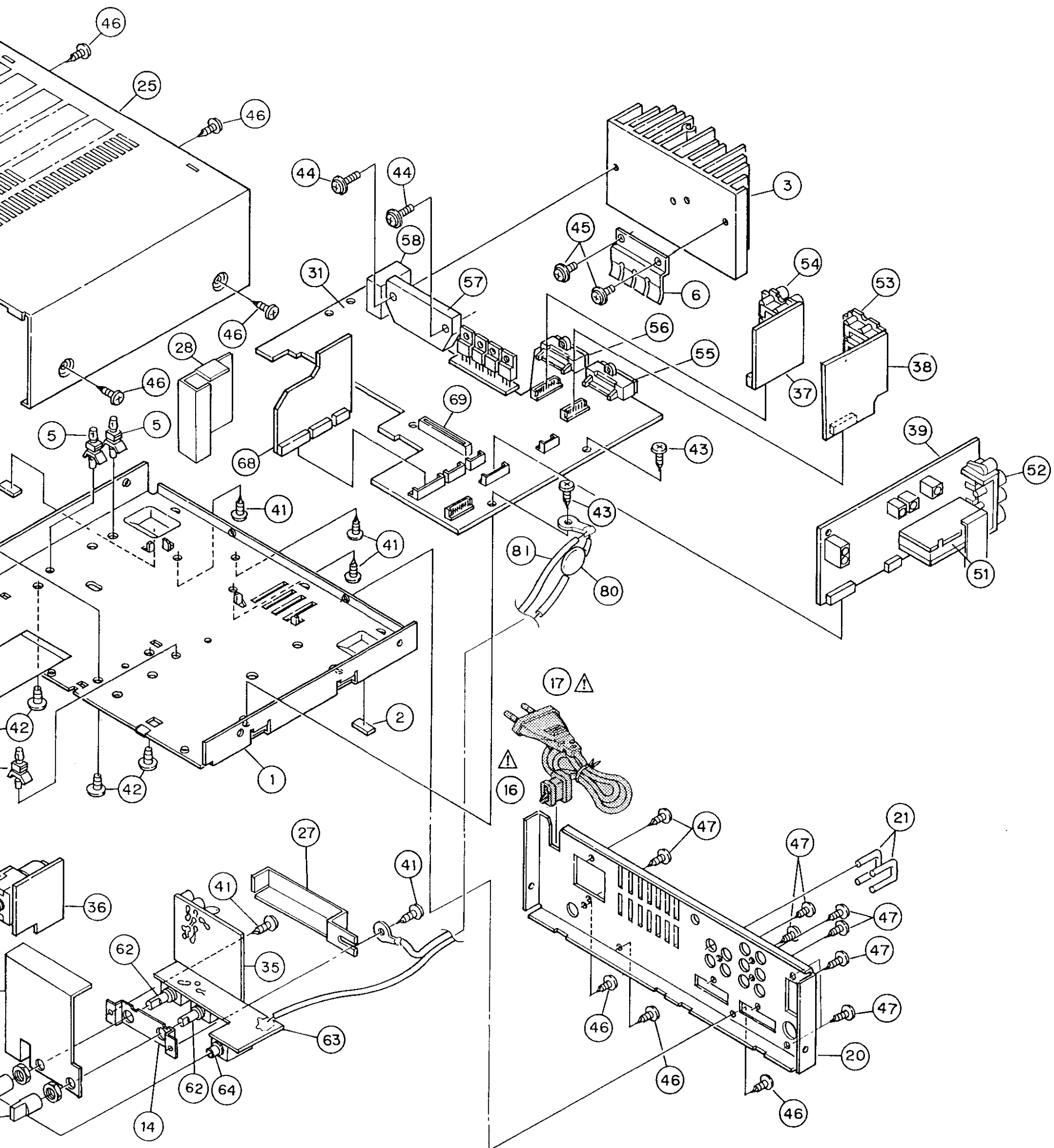
**NOTE FOR PARTS LIST**

- Part indicated with the mark "●" are not always in stock and possibly to take a long period of time for supplying, or in some case supplying of part may be refused.
- When ordering of part, clearly indicate "1" and "1" (i) to avoid mis-supplying.
- Ordering part without stating its part number can not be supplied.
- Part indicated with the mark "★" is not illustrated in the exploded view.

WARNING:

Parts marked with this symbol Δ  have critical characteristics. Use ONLY replacement parts recommended by the manufacturer.

REMOTE CONTROL UNIT

RECEIVER SECTION

(RC-148: Part No.: 3990156003)

1 2 3 4 5 6 7 8

● Schematic Diagram

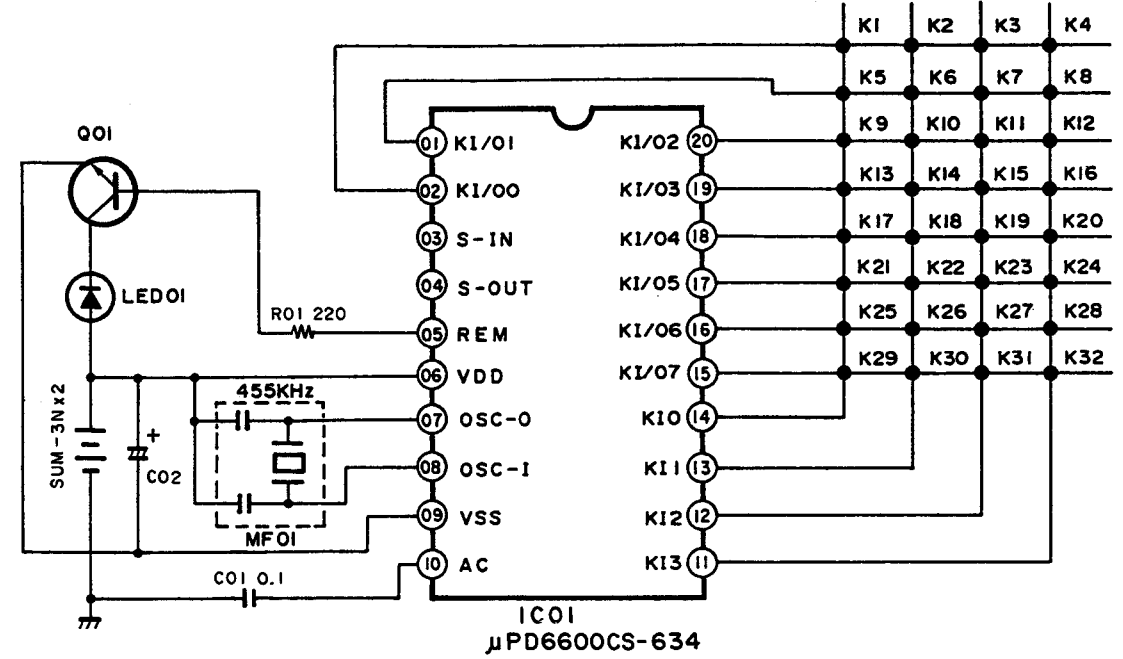

NOTES
 ALL RESISTANCE VALUES IN OHM K=1,000 OHM M=1,000,000 OHM
 ALL CAPACITANCE VALUES IN MICRO FARAD P=MICRO-MICRO FARAD
 EACH VOLTAGE AND CURRENT ARE MEASURED AT NO SIGNAL INPUT CONDITION.
 CIRCUIT AND PARTS ARE SUBJECT TO CHANGE WITHOUT PRIOR NOTICE.

Ref. No.	Part Name	Remarks
IC01	IC	μPD6600CS-634
Q01	Transistor	2SC3377 Q/R, 2SC2060 Q/R
LED01	Infrared LED	SE303ARF-C
C01	Ceramic Cap.	0.1 μF/25V
C02	Chemi Con.	47 μF/6.3V
MF01	Ceramic OSC.	CSU455PB
R01	Resistor	220Ω, 1/6W

KEY NO.	FUNCTION		
K 1	POWER ON/OFF	Receiver	○
K 2	VOLUME UP	Receiver	○
K 3	VOLUME DOWN	Receiver	○
K 4	SLEEP	Receiver	○
K 5	MUTING	Receiver	○
K 6	PRESET UP	Receiver	○
K 7	PRESET DOWN	Receiver	○
K 8	FUNCTION	Receiver	○
K 9	PRESET EQ	EQ	○
K10	AUTOMATIC SEARCH ►►	CD	○
K11	AUTOMATIC SEARCH ◄◄	CD	○
K12	MANUAL SEARCH ►►	CD	○
K13	MANUAL SEARCH ◄◄	CD	○
K14	PLAY ►	CD	○
K15	STOP ■	CD	○
K16	PROGRAM	CD	○
K17	TIME MODE	CD	○
K18	OPEN/CLOSE ▲	CD	○
K19	FF ►►	DECK	○
K20	REW ◄◄	DECK	○
K21	PLAY ►	DECK	○
K22	PLAY (REW) ◄	DECK	○
K23	STOP ■	DECK	○
K24	REC/REC MUTE ●	DECK	○
K25	SELECT 1/2	DECK	○
K26	OPEN/CLOSE ▲	DECK	○
K27	SP-A	Receiver	
K28	SP-B	Receiver	
K29	FLAT	EQ	
K30	PAUSE	CD	
K31	REC PAUSE	DECK	
K32	OPEN/CLOSE 2 ▲	DECK	

KEY NO.	System code					Data code					Expansion			Mask	Ruling	K	Remarks	
	C1	C2	C3	C4	C5	C6	C7	C8	C9	C10	C11	C12	C13					
K 1	0	0	1	1	0	0	0	0	0	1	0	1	0	0	0	0	POWER ON/OFF	Receiver
K 2	0	0	1	1	0	1	0	1	1	0	0	1	0	0	0	0	VOLUME UP	Receiver
K 3	0	0	1	1	0	0	0	1	1	0	0	1	0	0	0	0	VOLUME DOWN	Receiver
K 4	0	0	1	1	0	0	1	0	0	1	1	1	0	0	0	0	SLEEP	Receiver
K 5	0	0	1	1	0	1	1	0	1	0	0	1	0	0	0	0	MUTING	Receiver
K 6	0	0	1	1	0	0	1	1	0	0	1	0	0	0	0	0	PRESET UP	Receiver
K 7	0	0	1	1	0	1	1	1	1	0	0	1	0	0	0	0	PRESET DOWN	Receiver
K 8	0	0	1	1	0	1	1	1	1	1	0	1	0	0	0	0	FUNCTION	Receiver
K 9	0	0	0	1	0	0	0	1	1	0	1	1	1	0	0	0	PRESET EQ	EQ
K10	0	0	0	1	0	0	0	0	1	1	0	1	0	0	0	0	AUTOMATIC SEARCH ►►	CD
K11	0	0	0	1	0	1	0	0	1	1	0	1	0	0	0	0	AUTOMATIC SEARCH ◄◄	CD
K12	0	0	0	1	0	0	1	0	1	1	0	1	0	0	0	0	MANUAL SEARCH ►►	CD
K13	0	0	0	1	0	1	1	0	1	1	0	1	0	0	0	0	MANUAL SEARCH ◄◄	CD
K14	0	0	0	1	0	0	0	1	1	1	0	1	0	0	0	0	PLAY ►	CD
K15	0	0	0	1	0	0	1	1	1	1	0	1	0	0	0	0	STOP ■	CD
K16	0	0	0	1	0	1	0	1	1	0	0	1	0	0	0	0	PROGRAM	CD
K17	0	0	0	1	0	1	1	0	0	1	0	1	0	0	0	0	TIME MODE	CD
K18	0	0	0	1	0	0	0	0	0	1	0	1	0	0	0	0	OPEN/CLOSE ▲	CD
K19	0	0	1	0	0	0	1	0	1	1	0	1	0	0	0	0	FF ►►	DECK
K20	0	0	1	0	0	1	1	0	1	1	0	1	0	0	0	0	REW ◄◄	DECK
K21	0	0	1	0	0	0	0	1	1	1	0	1	0	0	0	0	PLAY ►	DECK
K22	0	0	1	0	0	1	1	1	0	1	0	1	0	0	0	0	PLAY (REW) ◄	DECK
K23	0	0	1	0	0	0	1	1	1	1	0	1	0	0	0	0	STOP ■	DECK
K24	0	0	1	0	0	1	1	1	1	1	0	1	0	0	0	0	REC/REC MUTE ●	DECK
K25	0	0	1	0	0	1	1	0	0	1	0	1	0	0	0	0	SELECT 1/2	DECK
K26	0	0	1	0	0	1	1	0	0	1	1	1	0	0	0	0	OPEN/CLOSE ▲	DECK
K27	0	0	1	1	0	0	1	0	1	0	1	1	0	0	0	0	SP-A	Receiver
K28	0	0	1	1	0	1	0	0	1	0	1	1	0	0	0	0	SP-B	Receiver
K29	0	0	0	1	0	1	1	1	1	0	0	1	1	0	0	0	FLAT	EQ
K30	0	0	0	1	0	1	0	1	1	1	0	1	0	0	0	0	PAUSE	CD
K31	0	0	1	0	0	1	0	1	1	1	0	1	0	0	0	0	REC PAUSE	DECK
K32	0	0	1	0	0	0	1	0	0	1	1	1	0	0	0	0	OPEN/CLOSE 2 ▲	DECK

● Transistors

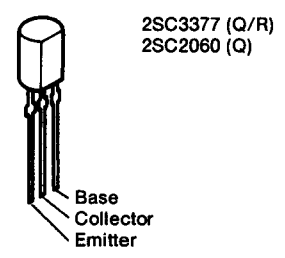

● Diodes

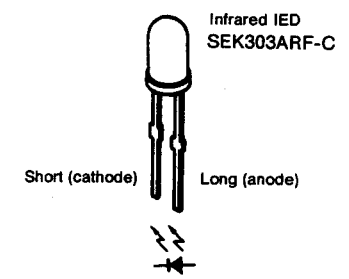

A
B
C
D
E

CASSETTE DECK SECTION

DISASSEMBLY PROCEDURES

(Follow these procedures in reverse order to reassemble.)

1. Removing the top cover and front panel

- ① Remove the six screws fastening the top cover.
- ② Lift the top cover in the direction of the arrow.
The top cover is caught in the three ribs in the front panel, so lift it straight upwards.

NOTE: The front panel hook will break if the top cover is not lifted straight upwards.

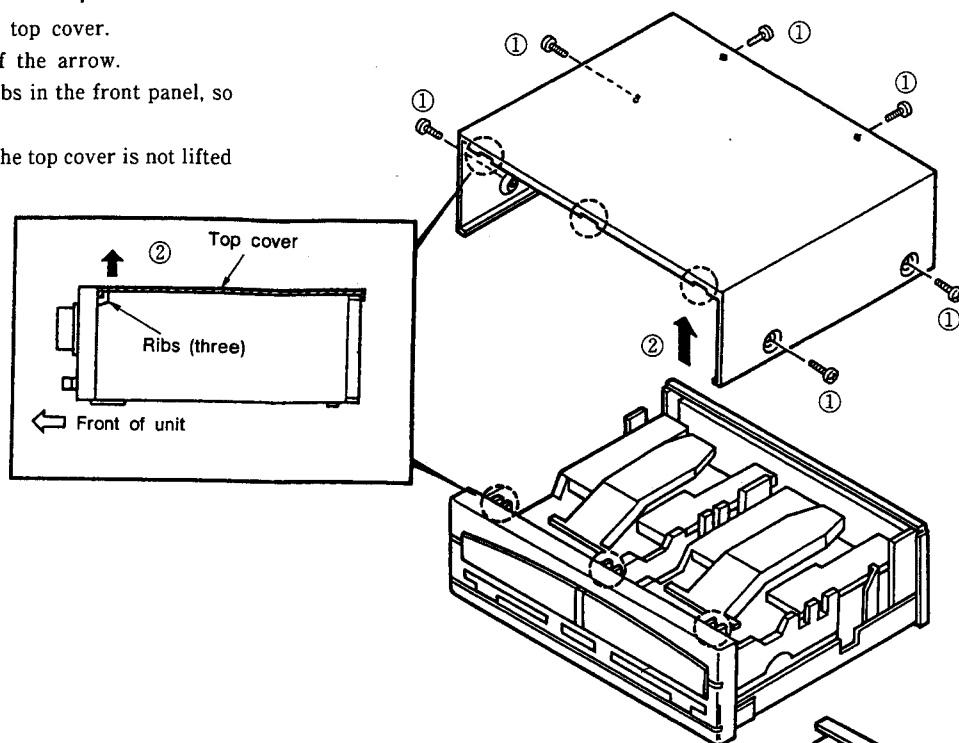

- ③ Set the unit up as shown in the diagram, then remove the two screws fastening the foot assembly.
- ④ Unlatch the hook of the front panel from the chassis and remove the front panel in the direction of the arrow.

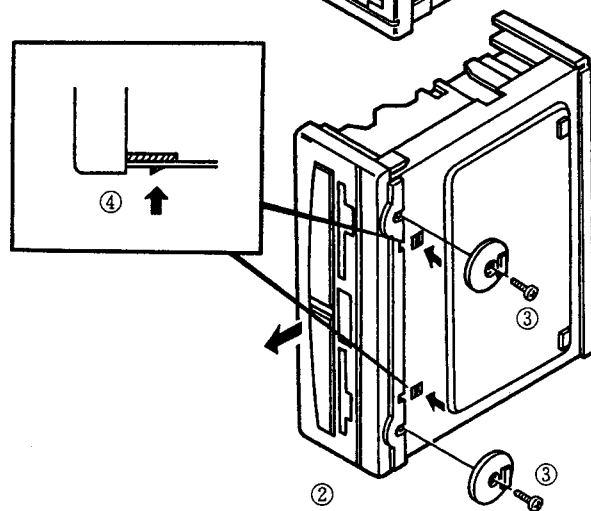

2. Removing the cassette mechanism unit

- ① Turn the main unit over as shown in the diagram and remove the two screws fastening the rear panel.
- ② Remove the eight screws fastening the cassette mechanism unit, then remove the cassette mechanism unit from the main chassis in the direction of the arrow.
- ③ When reinstalling the cassette mechanism unit, set the eight mechanism bosses into the main chassis.

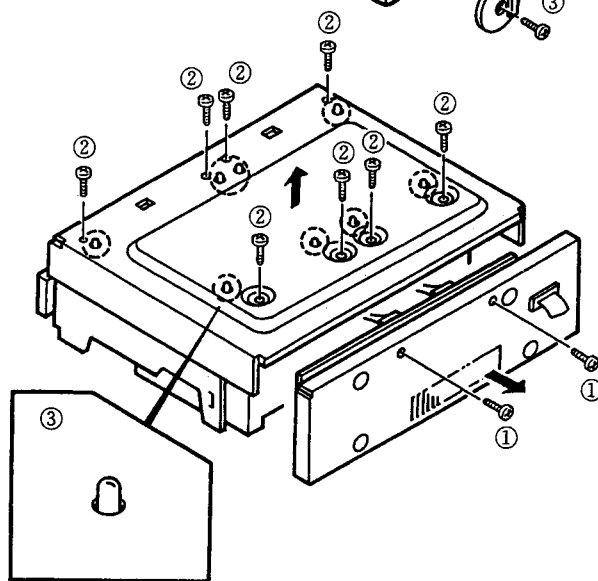

3. Removing the printed wiring boards

DECK DISPLAY UNIT KU-9257B-3

- ① Remove the eight screws fastening the deck display unit, then remove the printed wiring board in the direction of the arrow.

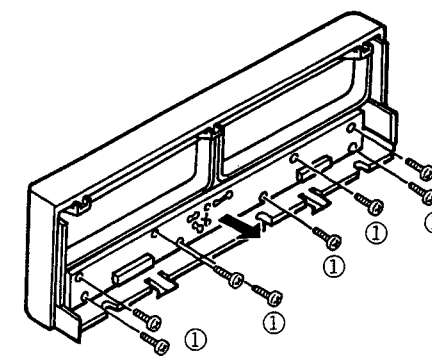

DECK UNIT (ANALOG) KU-9257B-1

- ① Remove the solder from the ground screw.
- ② Pressing down on the locking section of the connector, disconnect the wires in the direction of the arrow.
- ③ Unlatch the four PCB holders fastening the amplifier unit, using radio pliers, etc., then remove the circuit board in the direction of the arrow.

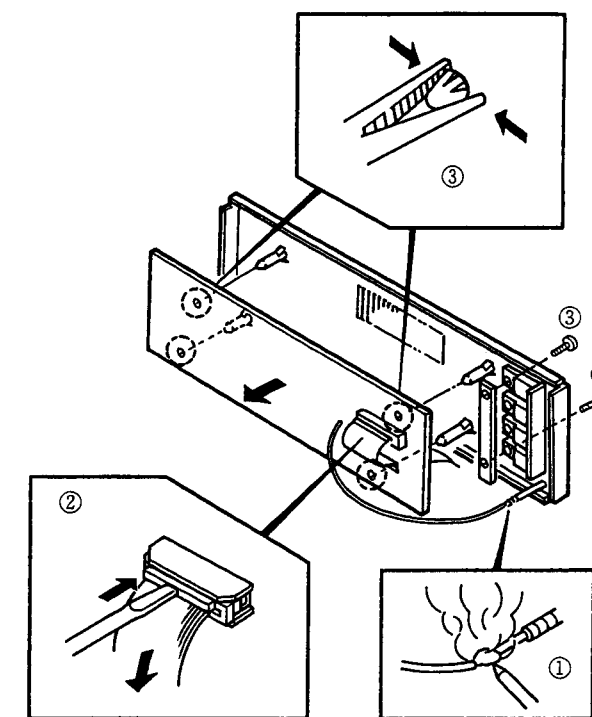

DECK UNIT (DIGITAL) KU-9257B-2

- ① Remove the main chassis. The deck unit (digital) is located under the insulating sheet.

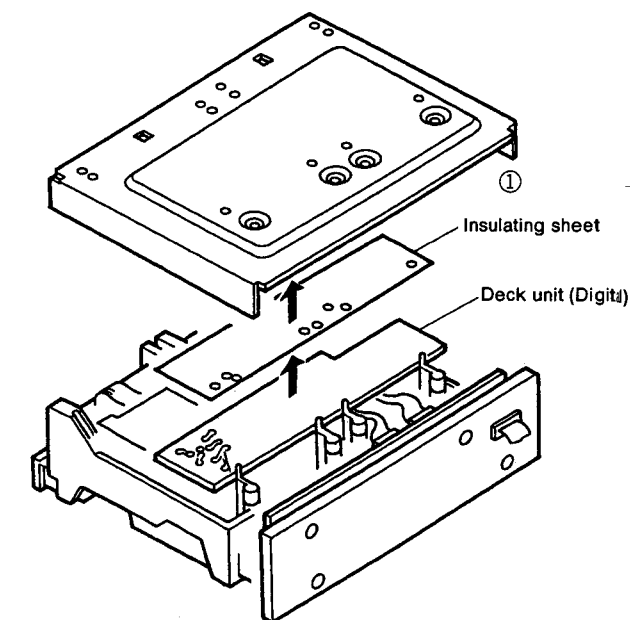

CASSETTE DECK SECTION

BLOCK DIAGRAM

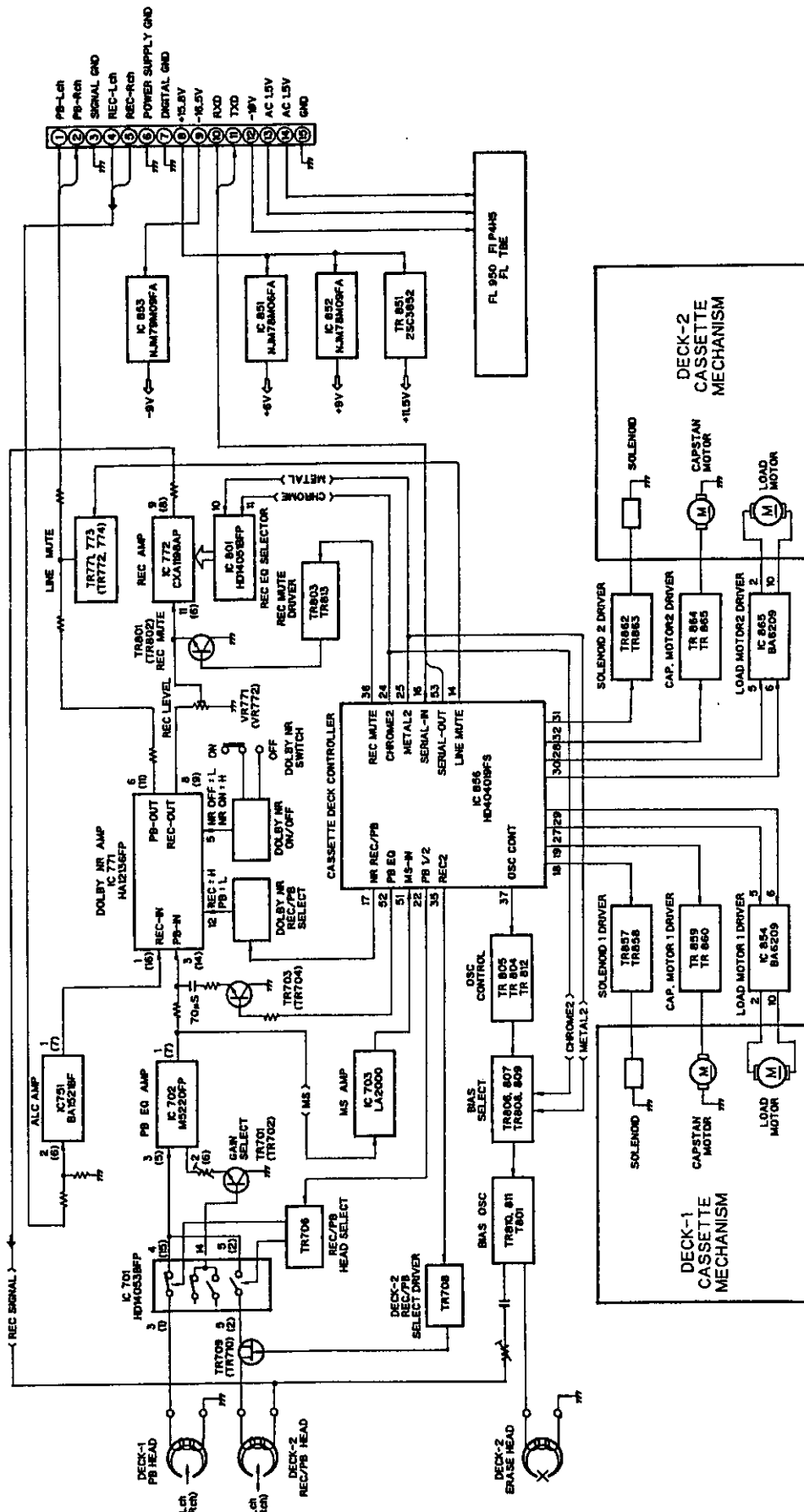

CASSETTE DECK SECTION

LEVEL DIAGRAM

(Playback)
 TCC-130 DOLBY B-TYPE
 400Hz 200nWb/m

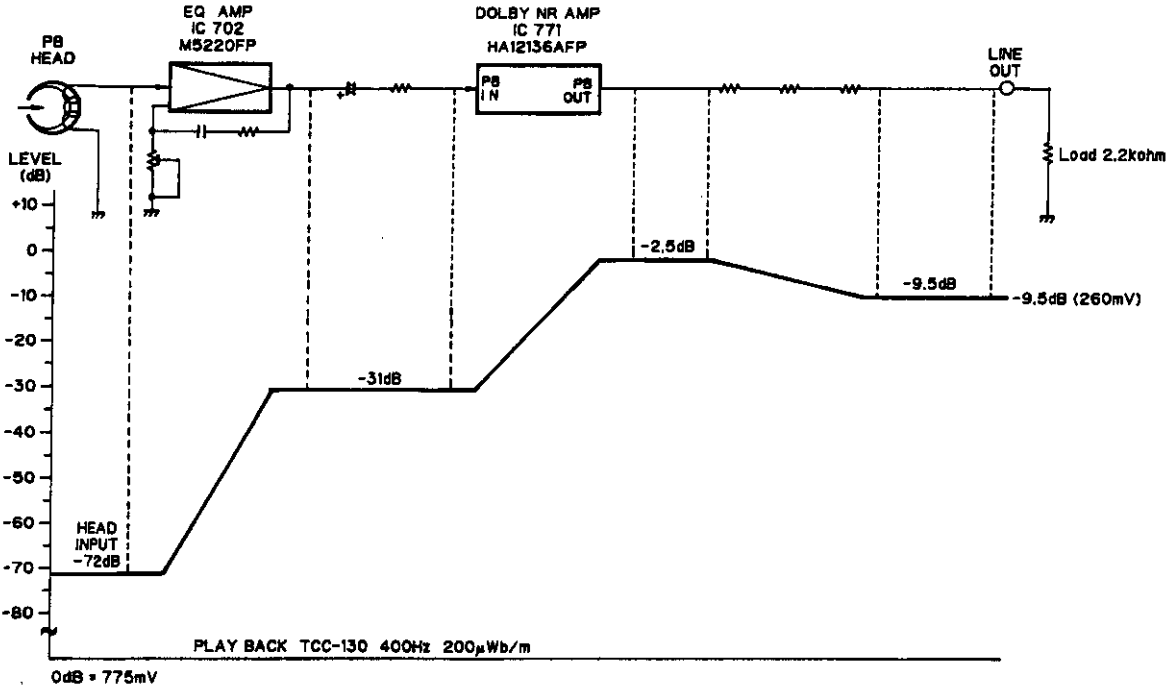

(Recording)
 INPUT FREQUENCY
 400Hz

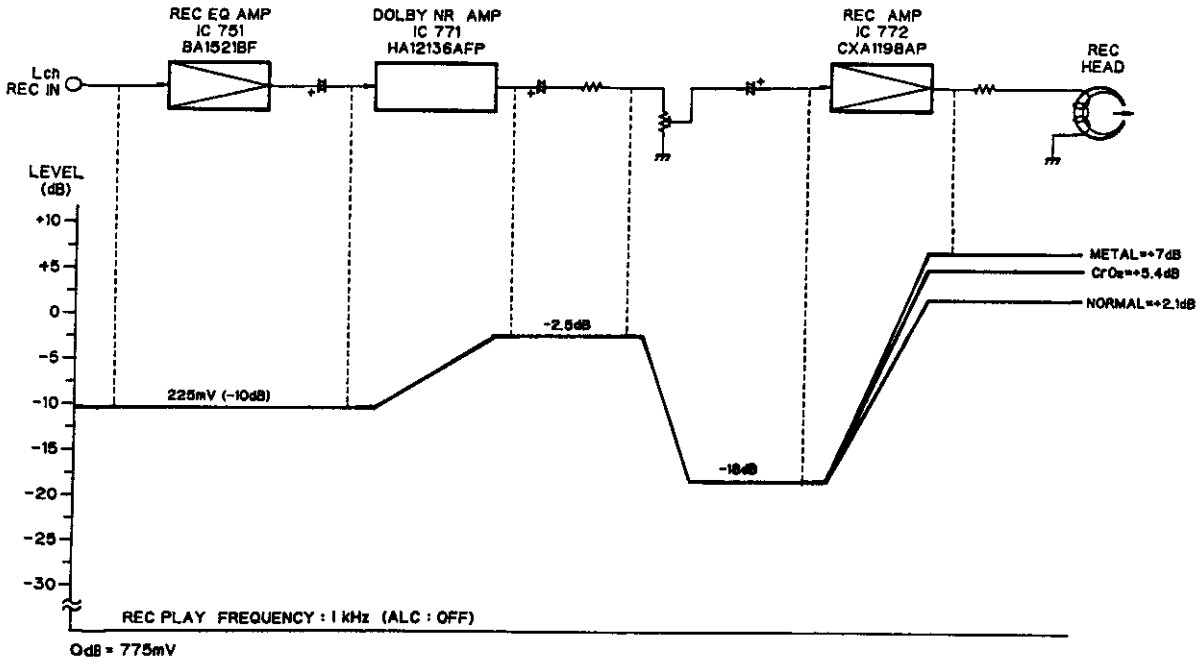

ADJUSTMENT

● Mechanism Measurements

Measurement item	Standard value	Remarks
Winding torque (PLAY)	35~70 gcm	SONY TW-2111 for forward, TW-2121 for reverse
Fast-forward and rewind torque	70~180 gcm	SONY TW-2231
Back tension torque	$2 \pm \frac{2}{13}$ gcm	SONY TW-2111 for forward, TW-2121 for reverse
Pinch roller pressure	270 ± 50 g	See diagram at right
Fast-forward and rewind time	110 ± 15 s	C-60

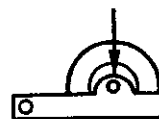

With the deck in the play mode, apply force with the tension gauge in the direction of the arrow and read the value at which the pinch roller stops rotating.

● ELECTRICAL ADJUSTMENTS

● Preparations Before Adjustments

1. Measuring Instruments Necessary for Adjustments

Screwdriver: Small flat-bladed screwdriver for variable resistors

- Low frequency oscillator
- Attenuator
- V.T.V.M.
- Oscilloscope
- Frequency counter
- Test tapes (TEAC MTT-111, MTT-114, MTT-150, DENON HDX/60, or equivalent)

● Adjustment notes

- ① Before adjusting, wipe the surface of the heads, the capstans, and the pinch rollers with a piece of gauze moistened with alcohol.
- ② Demagnetize the playback, recording, and erasure heads with a head eraser.
- ③ Completely demagnetize the adjustment screwdriver.
- ④ Adjust the attenuator for a recording input level of 22mV at the DAT/VTR P.B. Terminal.
- ⑤ Unless otherwise specified, set the switches at the following positions and use the P.B Terminal IN jacks for the input, and TP701 of the KU-9257B-1 (deck unit) for the output.
DOBLY NR SW: OFF
EQUALIZER SW: OFF
- ⑥ Use an alligator clip cord to short circuit TP-701 of the KU-9257B-1 deck board as shown in the diagram to the right and on Page 53.



2. Playback adjustments

2-1 Azimuth adjustment

Play back the (TEAC MTT-114) test tape and turn the azimuth adjustment screw to yield maximum values for the left and right channels.
Lock the screw.

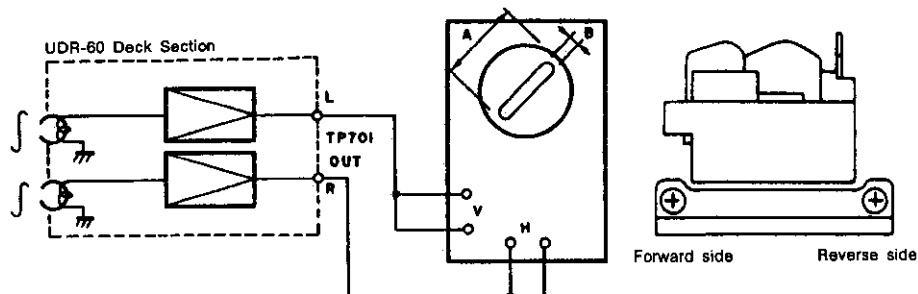

CASSETTE DECK SECTION

2-2 Tape speed check and adjustment

- Connect the frequency counter to TP-701.

- ① Play the test tape (MTT-111) on deck 1 and once tape transport has stabilized, adjust normal-speed-adjustment variable resistor (motor Variable Resistor) to yield $3,000 \text{ Hz} \pm 10 \text{ Hz}$.
- ② Using the same procedure on deck 2, adjust variable resistor (motor Variable Resistor).

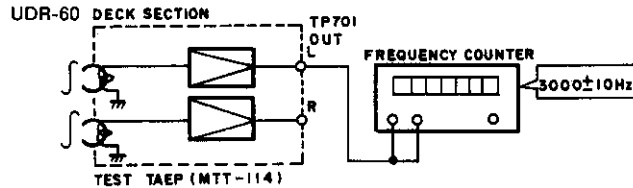

2-3 Playback level check and adjustment

Play a Dolby reference level tape (TEAC MTT-150) and check that the voltage of the left and right monitor outputs of TP-702 on the KU-9257B-1 deck board is within $580 \text{ mV} \pm 1 \text{ dB}$.

If it is not within this range, the playback level requires adjustment.

NOTE: When adjusting deck 1, the playback level of deck 2 also changes; therefore, the playback level of deck 2 should be readjusted.

- For deck 1, adjust: VR703 (Left channel), and VR704 (right channel)
- For deck 2, adjust: VR701 (Left channel), and VR702 (right channel)

Caution: Always adjust the playback level starting from the left deck first.

3. Recording adjustments (deck 2 only)

3-1 Overall frequency response adjustment for recording and playback

Load a blank DENON HDX/60 tape for adjustment purposes and record and play it back, adjusting the input attenuators of the 1 kHz and 10 kHz signals to yield a left and right monitor output voltage of 58 mV at TP702 of the KU-9257B-1 deck board. Adjust so that the 10 kHz level is about +0.5 dB with respect to 1 kHz, and the overall response is within the range shown in the diagram below.

- If the 10 kHz output is larger than the 1 kHz output, turn VR801 (left channel) and VR802 (right channel) counterclockwise, and if it is smaller, turn these controls clockwise.

3-2 Recording level check and adjustment

Load a blank DENON HDX/60 tape for adjustment purposes and check that the voltmeter indication is within the $58 \text{ mV} \pm 1 \text{ dB}$ range when a 1 kHz signal is recorded and played back.

If it is not within this range, the recording level requires adjustment.

- If the level at the time of playing back the recording is higher than at the time of recording, turn VR771 (left channel) and VR772 (right channel) counterclockwise, and if lower, turn these controls clockwise.

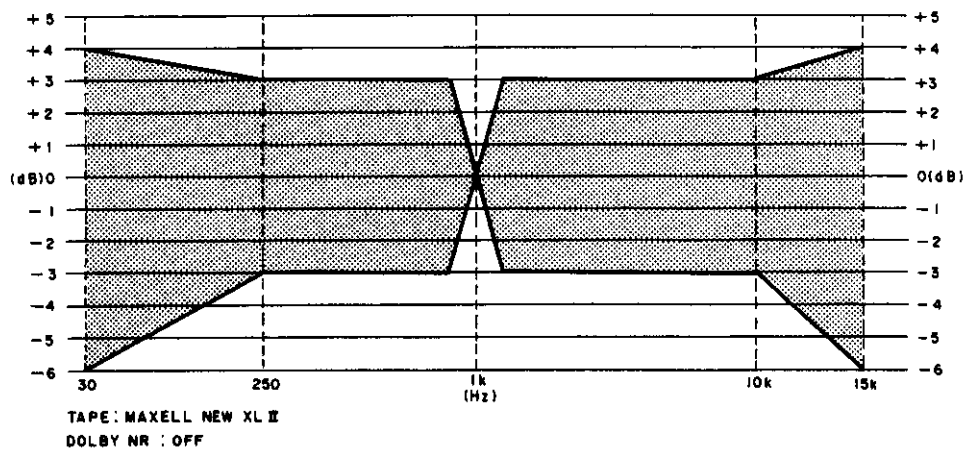

CASSETTE DECK SECTION

OUTLINE DIAGRAM OF ADJUSTMENT LOCATION

KU-9257B-1 DECK UNIT (ANALOG) ASS'Y (Component Side)

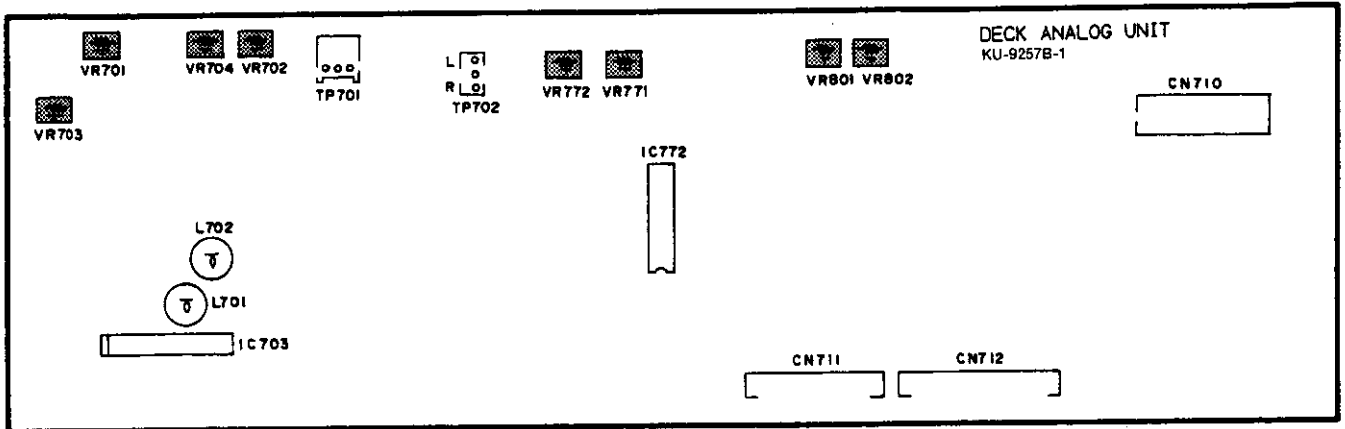

← FRONT PANEL SIDE

CASSETTE DECK SECTION

SEMICONDUCTORS

IC's

NJM78M06FA (S) (IC851)
NJM78M09FA (S) (IC852)
(Three-terminal positive constant voltage power supply)

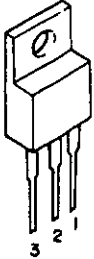

1: Output
2: GND
3: Input

BA6209 (IC854, 855)

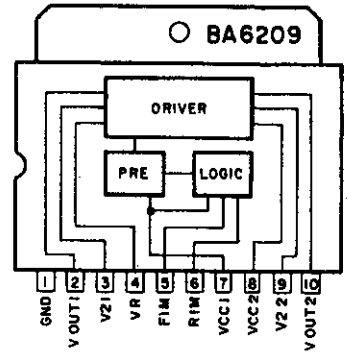
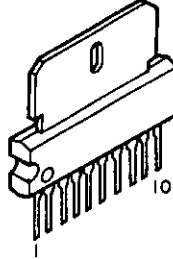

NJM79M09FA (IC853)
(Three-terminal negative constant voltage power supply)

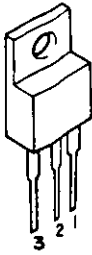

1: Output
2: Input
3: GND

CXA1198AP (IC772)

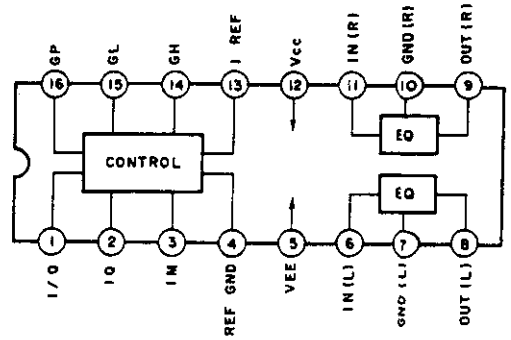
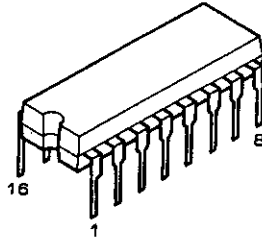

LA2000 (IC703)

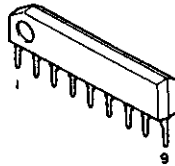

M5220FP (IC702)
BA15218FP (IC751,752)

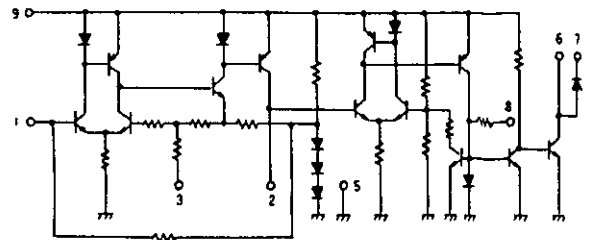
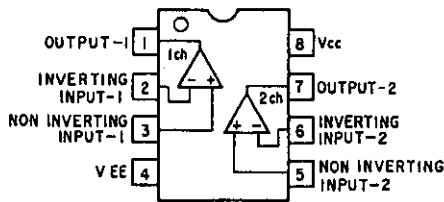
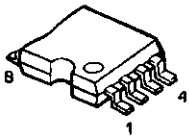

HD14051BFP (IC801)
HD14053BFP (IC701)

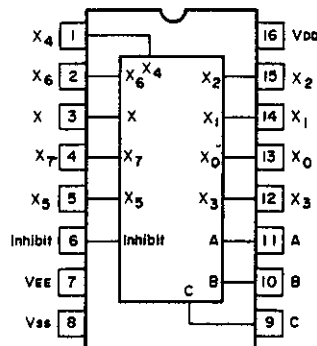
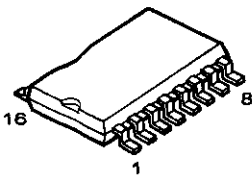

HD14051BFP

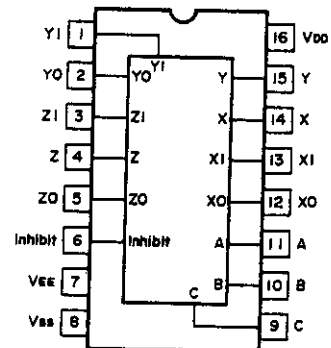

HD14053BFP

CASSETTE DECK SECTION

HA12136AFP (IC771)

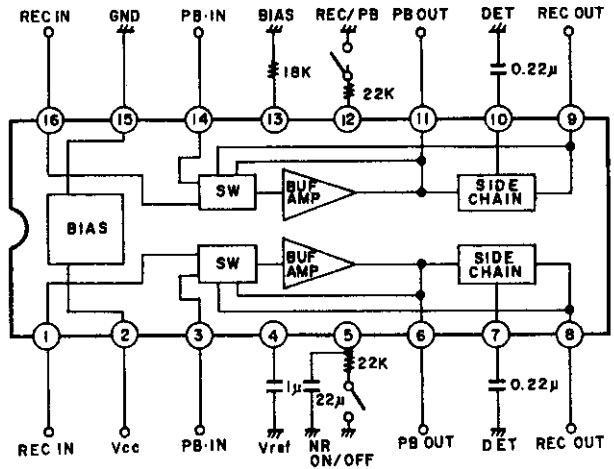
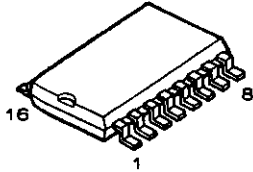

($T_a = 25^\circ\text{C}$, $V_{cc} = 12\text{V}$, at time of no signal, constant values in the table are standard values.)

Pin No.	Symbol	R (In)	V DC	Equivalent circuit	Notes
1.16	REC IN	56k ohm	6.0V		Recording (Encode) input
2	Vcc	-	12.0V		Power supply
3.14	PB IN	100k ohm	6.0V		Playback (Decode) input
4	VREF	-	6.0V		Reference voltage
5	NR ON/OFF	-	-		Mode control pin for NR ON/OFF "H" → NR ON "L" → NR OFF
6.11	PB OUT	-	6.0V		Playback (Decode) output

Pin No.	Symbol	R (In)	V DC	Equivalent circuit	Notes
7.10	DET	-	1.3V		Time constant pin for the level detector
8.9	REC OUT	-	6.0V		Recording (Encode) output
12	REC/PB	-	-		Mode control pin for REC/PC (Encode/Decode) "H" → REC (Encode) "L" → PB (Decode)
13	BIAS	-	1.0V		Reference current input pin for the active filters "H" → PB (Decode)
15	GND	-	0V		Ground

M62005L (IC857)

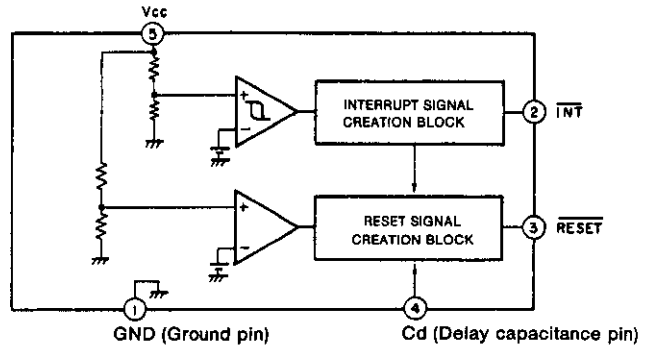
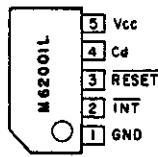
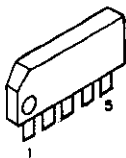

CASSETTE DECK SECTION

● **Transistors**

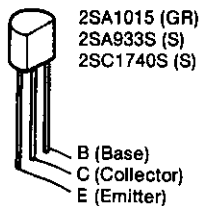

2SB562 (C)

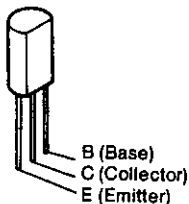

DTC114ES... NPN Type

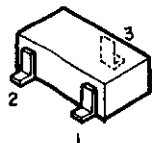
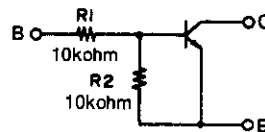
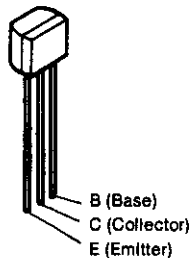

- 1: GND/Emitter
- 2: In/Base
- 3: Out/Collector

DTAEK Series

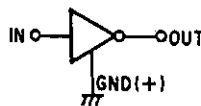
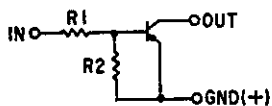

2SB1307M (Q)



- 1: Emitter
- 2: Collector
- 3: Base

	R1	R2
DTA114EK	10k ohm	10k ohm

- DTA114EK ... PNP Type
- DTC114EK
- DTC114TK
- DTC124EK ... NPN Type
- DTC144EK
- DTC323TK

DTCEK Series

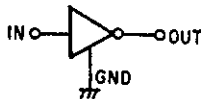
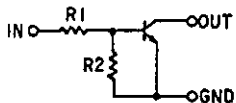

DTCTK Series

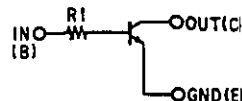

	R1	R2
DTC114EK	10k ohm	10k ohm
DTC124EK	4.7k ohm	4.7k ohm
DTC144EK	47k ohm	47k ohm

	R1
DTC114TK	1.0k ohm
DTC323TK	10k ohm

2SC3852

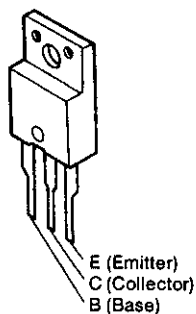

(Chip)
2SC2412K (S)

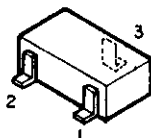

- 1: Emitter
- 2: Base
- 3: Collector

FET 2SK373 (Y)

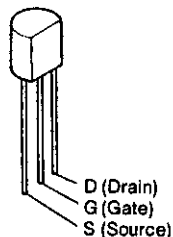

CASSETTE DECK SECTION

● Diodes (including LED)

HZS3B-2 HZS4A-1
HZS12A-1 HZS7B-3
HZS4C-1 HZS6C-2
HZS6A-1 HZS20-1



1SS270A



1SR35-200A



SLR-37VR (Red)
SLR-37MG (Green)

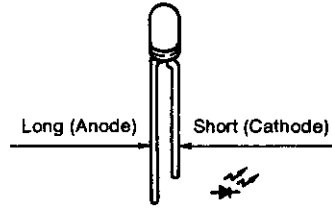

● FLD Ass'y (FIP4H5)

Part No.: 3934135006

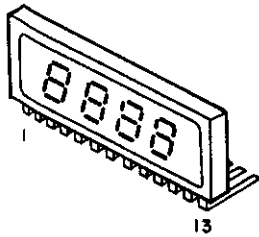

CASSETTE DECK SECTION

MICROPROCESSOR DOCUMENTATION

HD404019RB68FS: Part No.2621584107
 (CMOS 4-bit single chip microprocessor)
 (IC856)

- Major functions
 - Deck control
 1. Deck mechanism control use and signal circuits, control output
 2. Cuing operation, continuous playback
 3. CD synchro operation
 4. Auto function operation

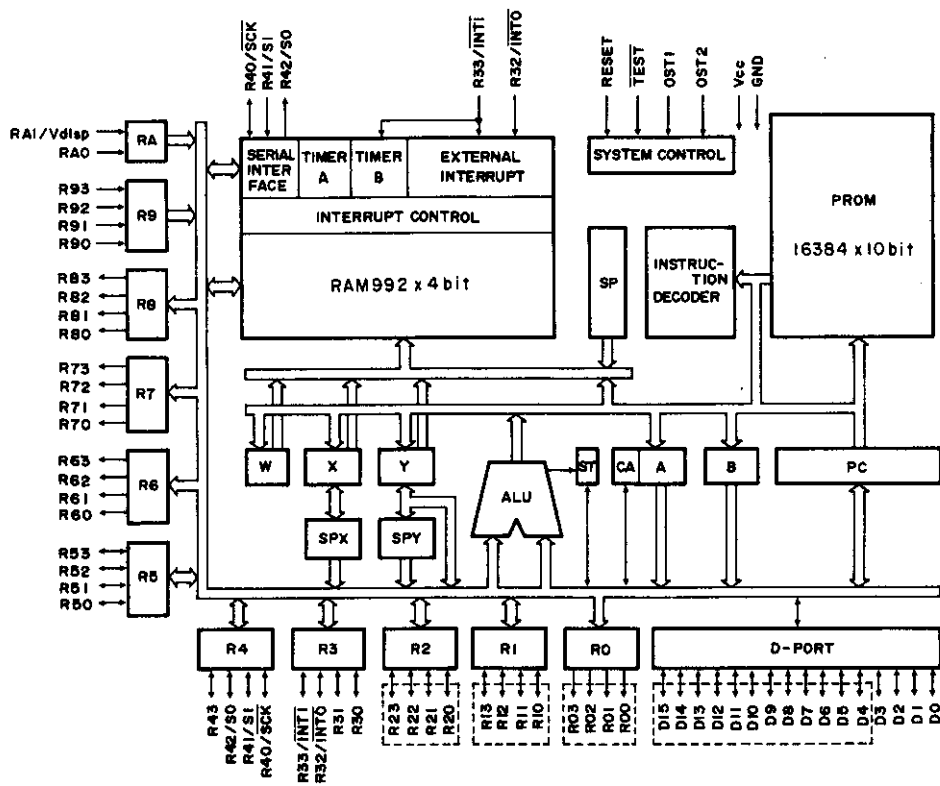
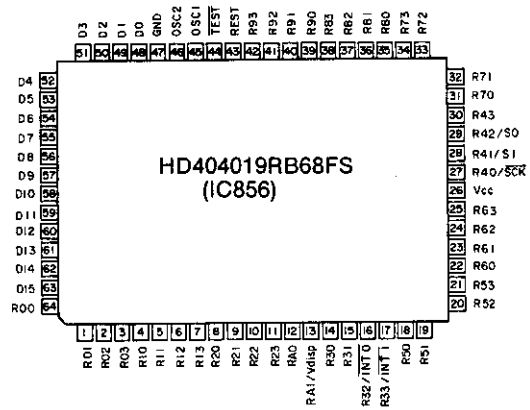
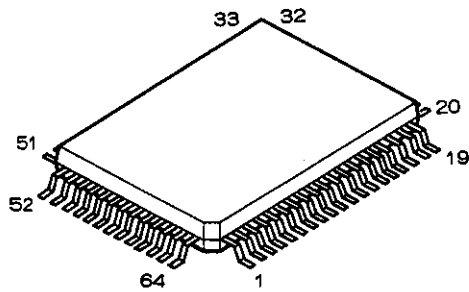

High withstand voltage terminal

CASSETTE DECK SECTION

● Pin Description

NO	Pin name	I/O	Signal name	Function
1	R01	O	T 1	Strobe signal output pin of the LED matrix. (Active high)
2	R02	O	T 2	Strobe signal output pin of the LED matrix. (Active high)
3	R03	O	T 3	Strobe signal output pin of the LED matrix. (Active high)
4	R10	O	L. SPEED 1 OUT	Control output pin for slowing down the loading speed of deck 1.
5	R11	O	L. SPEED 2 OUT	Control output pin for slowing down the loading speed of deck 2.
6	R12	I	Q. SENS 1 IN	QUICK SENSE input pin of deck 1. (Active low)
7	R13	I	Q. SENS 2 IN	QUICK SENSE input pin of deck 2. (Active low)
8	R20	O	RESET OUT	When the power is switched on, this pin outputs a high-level signal for 4 seconds after reset start up, then it outputs a low-level signal.
9	R21	O	CROM 2 OUT	An output pin which switches the recording equalizer of deck 2 to chrome. (Active high)
10	R22	O	METAL 2 OUT	An output pin which switches the recording equalizer of deck 2 to metal. (Active high)
11	R23	O	POWER ON/OFF OUT	This pin controls the on/off switching of the power. It is high level when power is on, and low level when power is off.
12	RA0	I	REEL T. 1 IN	Reel pulse input pin of the take-up side (right side) of deck 1.
13	RA1	I	REEL T. 2 IN	Reel pulse input pin of the take-up side (right side) of deck 2. There is a transition to the stop mode when a pulse continues for 2 seconds in the play or record modes, or for 1 second in the fast forward, rewind, cue, or review modes. Note that the 1 second following the start of tape transportation is not detected. The input pulse width is measured and if it falls below the determined value, the tape end display is shown.
14	R30	O	LINE MUTE OUT	Mute output pin of the playback output pins. (Active high) Outputs a low-level signal when deck 1 or deck 2 is in the play, record, record pause, record mute, or dubbing mode, and outputs a high-level signal at other times.
15	R31	I	STAND BY IN	This pin sets the standby mode of the microprocessor. The tape counter value and the directions of timer record and play, as well as other information is backed up by the input of this pin. (Active low)
16	R32	I	SERIAL IN	Serial communications input pin. (Active low)
17	R33	I	50/60 Hz IN	This pin takes in the power frequency of 50 Hz or 60 Hz.
18	R50	O	PLAY SOL 1 OUT	This pin outputs the pulse which drives the solenoid of mechanism 1. (Active high)
19	R51		CPM 1 OUT	This pin outputs the pulse which drives the capstan motor of mechanism 1. (Active high)
20	R52	O	HI-SP 1 OUT	Switching output for speeding up the rotation speed of the capstan motor of mechanism 1 at the time of high-speed dubbing.
21	R53	I	REEL S. 1 IN	Reel pulse input pin of the supply side (left side) of deck 1.
22	R60	O	PLAY 1/2 OUT	This output pin indicates which mechanism is in the play mode. Low level when mechanism 1 is playing. High level when mechanism 2 is playing.
23	R61	I	CROM 1 IN	Tape type detection switch input of mechanism 1. Low level for normal tape and high level for chrome or metal tape.
24	R62	I	CROM 2 IN	Tape type detection switch input of mechanism 2.
25	R63	I	METAL 2 IN	Tape type detection switch input of mechanism 2.
26	Vcc			Power supply input pin. Used for backup.
27	R40	O	OPEN 1 OUT	Output pin for opening the loader of mechanism 1. (Active high)
28	R41	O	OPEN 2 OUT	Output pin for opening the loader of mechanism 2. (Active high)
29	R42	O	CLOSE 1 OUT	Output pin for closing the loader of mechanism 1. (Active high)
30	R43	O	CLOSE 2 OUT	Output pin for closing the loader of mechanism 2. (Active high)
31	R70	O	PLAY SOL 2 OUT	This pin outputs the pulse which drives the solenoid of mechanism 2. (Active high)
32	R72	O	CPM CONT 2 OUT	This pin outputs the pulse which drives the capstan motor of mechanism 2. (Active high)
33	R73	O	HI-SP 2 OUT	Switching output for speeding up the rotation speed of the capstan motor of mechanism 2 at the time of high-speed dubbing.
34	R74	I	REEL S. 2 IN	Reel pulse input pin of the supply side (left side) of deck 2.
35	R80	O	REC 2 OUT	Record mode output pin of deck 1. High level in the record mode.

NO	Pin name	I/O	Signal name	Function
36	R81	O	REC MUTE 2 OUT	This output pin controls the muting of the recording amp input of deck 1.
37	R82	O	OSC CONT 2 OUT	This output pin controls the bias oscillation of deck 2.
38	R83	O	HI-SP REC OUT	This output pin is used to switch the time constant of the signal system at the time of high-speed dubbing.
39	R90	I	KR 0 IN	Key and switch input pin.
40	R91	I	KR 1 IN	Key and switch input pin.
41	R92	I	KR 2 IN	Key and switch input pin.
42	R93	I	KR 3 IN	Key and switch input pin.
43	RESET	I		Reset pin.
44	TEST	I		Connect to Vcc.
45	OSC1	I		System clock oscillation pin. 4 MHz
46	OSC2	O	R 5	System clock oscillation pin.
47	GND			Ground pin.
48	D 0	O	A	Fluorescent tube drive segment and key strobe output.
49	D 1	O	B	Fluorescent tube drive segment and key strobe output.
50	D 2	O	C	Fluorescent tube drive segment and key strobe output.
51	D 3	O	D	Fluorescent tube drive segment and key strobe output.
52	D 4	O	E	Fluorescent tube drive segment and key strobe output.
53	D 5	O	F	Fluorescent tube drive segment and key strobe output.
54	D 6	O	G	Fluorescent tube drive segment and key strobe output.
55	D 7	O	H	Key strobe output.
56	D 8	O	I	Key strobe output.
57	D 9	O	J	Key strobe output.
58	D10	O	LED 0	Output pin for mode display LED drive.
59	D11	O	LED 1	Output pin for mode display LED drive.
60	D12	O	LED 2	Output pin for mode display LED drive.
61	D13	O	PB EQ OUT	Output for switching the time constant of the playback amp. Low level for 120 μ s and high for 90 μ s.
62	D14	I	MS IN	Input pin of the between track detection signal from the IC used for between track detection. (Active low)
63	D15	O	SERIAL	Input pin for serial communications. (Active low)
64	R00	O	T 0	Strobe signal output pin of the LED matrix.

CASSETTE DECK SECTION

● Description of key inputs

Item	Key name	Description of function
1	F. PLAY 1,2	Commands the play mode in the forward direction. Commands the cue/revue mode with PLAY+REW/FF, or with FF/REW input during the play mode.
2	R. PLAY 1,2	Commands the play mode in the reverse direction. The transition to the cue/revue mode is the same as with F. PLAY.
3	FF 1,2	Commands fast winding of the tape to the right.
4	REW 1,2	Commands fast winding of the tape to the left.
5	REC/REC PAUSE 2	Commands the record mode. Commands the record pause mode when the deck is switched on from the stop mode. Commands the record mode when switched on simultaneously with PLAY. The "record conditions" must be satisfied.
6	REC/REC MUTE 2	Commands the record mode. Commands the record pause mode when the deck is switched on from the stop mode. Commands the record mute mode when switched on in the record or record pause mode. After 6 seconds of the record mute operation, there is a transition to the record pause mode. When there is key input again after 6 seconds have passed, the record mute mode is continued and there is a transition to the record pause mode when the key goes off.
7	STOP 1,2	Commands the stop mode. This key input will cause a transition to the stop mode, no matter what mode the deck is in. This key takes priority over all keys.
8	NORMAL DUBB	Commands the normal dubbing mode. The condition for reception for both decks 1 and 2 is that they are in the stop mode. CASS LOAD 1 and 2 are high level. ANTI REC FWD 2 is high level.
9	HI-SPEED DUBB	Commands the high-speed dubbing mode. The condition for reception is the same as that NORMAL DUBB.
10	CD SRS	A single touch commands recording synchronized with CD.
11	OPEN/CLOSE 1	This key opens and closes the loader of deck 1.
12	OPEN/CLOSE 2	This key opens and closes the loader of deck 2.
13	COUNTER RESET	This key resets the count value and display of the tape counter to "0000".
14	MEMORY STOP	This key causes the deck to stop when the count value of the tape counter reaches "0000" in the fast forward or rewind mode. Toggle operation.
15	SELECT 1/2	Changes the selection condition of the mechanism. Key input. The counter display also is switched with deck 1 and 2. The counter reset and memory stop functions are also switched accompanying this. Toggle operation. Deck 2 is set as the default.

Note: Key and Switch Input Processing

The key and switch inputs are always acanned and taken in. The minimum input width of the input is set at 30 ms, and a chattering prevention function must be supplied.

● Description of switch inputs

Item	Switch name	Description of function
1	REVERSE MODE REKVERSE CONTINUOUS	Command input switch for whether or not to reverse at the end of the tape during recording and playback (i.e., auto stop and quick sense input). When on, there is reversal at the end of side A, then side B is recorded or played back. See REVERSE MODE. When there is no switch input from either REVERSE or CONTINUOUS, the normal mode is set and there is no reversal.
2	TIMER PLAY	After the RESET input when the power is switched on, this input will cause a transition to the play mode from the mechanism and direction which are backed up in RAM. See TIMER PLAY.
3	TIMER REC	After the RESET input when the power is switched on, this input will cause a transition to the record mode from the mechanism and direction which are backed up in RAM. See TIMER REC.
4	QUICK SEL	This input switch takes in the QUICK SENSE input and judges whether or not to perform the reversing operation. Connection is made with a diode. When the diode is shorted, the reversing operation is performed. When the diode is open, the reversing operation is not performed.
5	POWER SEL	This input judges whether or not to perform the AUTO POWER ON/OFF operation. Connection is made with a diode. When the diode is shorted, the operation is performed. When the diode is open, the operation is not performed.
6	LOAD IN 1	This switch input indicates that the loader of deck 1 is closed. When the switch is shorted, the loader is closed. (The reading is high level.) When the switch is open, the loader is not closed.

Item	Switch name	Description of function
7	LOAD IN 2	This switch input indicates that the loader of deck 2 is closed.
8	LOAD OUT 1	This switch input indicates that the loader of deck 1 is open. When the switch is shorted, the loader is closed. (The reading is high level.) When the switch is open, the loader is not closed.
9	LOAD OUT 2	This switch input indicates that the loader of deck 2 is open.
10	LOAD SPEED 1	This switch input commands a slowing of the loading speed of deck 1.
11	LOAD SPEED 2	This switch input commands a slowing of the loading speed of deck 2.
12	CASSET LOAD 1	This switch input indicates whether a cassette tape is loaded in mechanism 1. When the switch is shorted, there is a tape. (The reading is high level.) When the switch is open, there is no tape. (The reading is low level.)
13	MODE SW 1	This switch input takes in the mode of mechanism 1. This switch input and the timer manage whether the transition between modes of the mechanism is performed properly.
14	CASSET LOAD 2	This switch input indicates whether a cassette tape is loaded in mechanism 2. When the switch is shorted, there is a tape. (The reading is high level.) When the switch is open, there is no tape. (The reading is low level.)
15	MODE SW 2	This switch input takes in the mode of mechanism 2. This switch input and the timer manage whether the transition between modes of the mechanism is performed properly.
16	ANTI REC F 2	This switch judges whether it is possible to record in the forward direction of deck 2. When the switch is shorted, it is possible. (The reading is high level.) When the switch is open, it is not possible. (The reading is low level.)
17	ANTI REC R 2	This switch judges whether it is possible to record in the reverse direction of deck 2. When the switch is shorted, it is possible. (The reading is high level.) When the switch is open, it is not possible. (The reading is low level.)
18	END SEL	Selection switch for whether or not the tape end indication is shown. Selection is by diode. When the diode is shorted, there is an indication. When the diode is open, there is no indication.

● Display

The unit is equipped with the following 2 types of display functions.

- Fluorescent tube tape counter display
- LED mode display

1. Fluorescent Tube Tape Counter Display

The reel pulses of each mechanism are counted and displayed here.

A tape end display is shown in the vicinity of the end of the tape.

For details, see the section covering the tape counter operation.

- Fluorescent tube used: NEC FIP4H5 4 digits, 7 segments
- Display timing: Display frequency Hz
On time per digit μs
Blanking time per digit μs

(A frequency for the display frequency is to be selected so as not to give rise to flickering under fluorescent lighting of 50 Hz and 60 Hz.)

Display Contents

Segment	Digit → Port ↓	T 0	T 1	T 2	T 3
		Thousands digit	Hundreds digit	Tens digit	Ones digit
A		a	a	a	a
B		b	b	b	b
C		c	c	c	c
D		d	d	d	d
E		e	e	e	e
F		f	f	f	f
G		g	g	g	g

2. LED Mode Display

- The REC LED indicates the REC mode. When the various mechanisms are:

A. in the record or record pause modes, the display lights up.

The timing for the lighting is according to the time chart.

B. in the record mute mode, the display blinks at an interval of 0.75 seconds. (The display-on and display-off periods are each 0.75 seconds.)

C. The display is off in other modes.

D. The REC LED is not to go off in the reverse modes.

- DUBBING LED

A. Blinks during dubbing.

During normal speed dubbing — Blinks at an interval of 0.75 seconds. (Display-on and display-off periods are each 0.75 seconds.)

During high-speed dubbing — Blinks at an interval of 0.30 seconds. (Display-on and display-off periods are each 0.30 seconds.)

B. Turns off when the dubbing mode is cancelled.

MICROPROCESSOR PERIPHERAL WIRING DIAGRAM

1 2 3 4 5 6 7 8

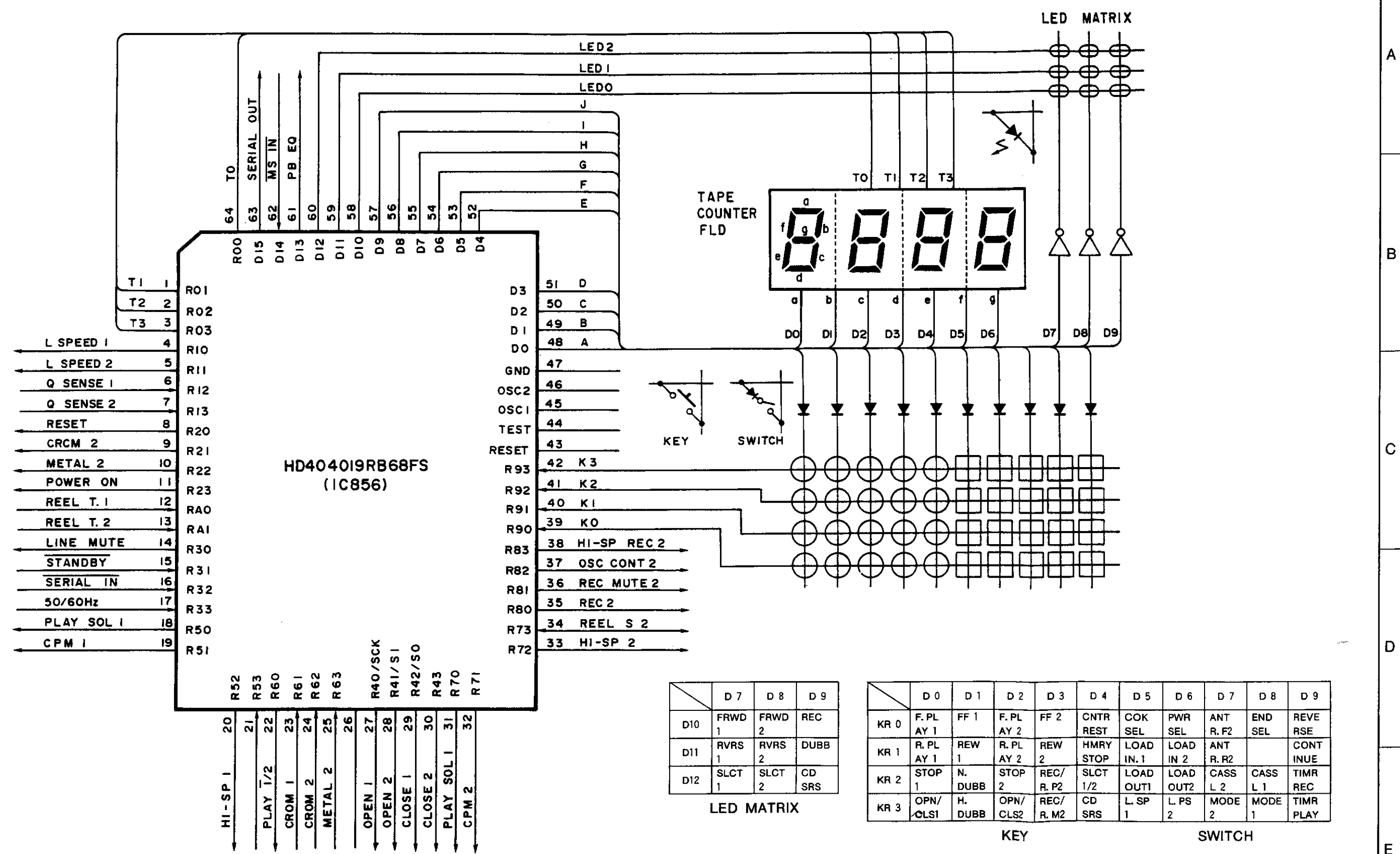

	D 7	D 8	D 9
D10	FRWD 1	FRWD 2	REC
D11	RVRS 1	RVRS 2	DUBB
D12	SLCT 1	SLCT 2	CD SRS

LED MATRIX

	D 0	D 1	D 2	D 3	D 4	D 5	D 6	D 7	D 8	D 9
KR 0	F. PL AY 1	FF 1	F. PL AY 2	FF 2	CNTR REST	COK SEL	PWR SEL	ANT R. F2	END SEL	REVE RSE
KR 1	R. PL AY 1	REW 1	R. PL AY 2	REW 2	HMRY STOP	LOAD IN. 1	LOAD IN 2	ANT R. R2		CONT INUE
KR 2	STOP 1	N. DUBB	STOP 2	REC/ R. P2	SLCT 1/2	LOAD OUT1	LOAD OUT2	CASS L 2	CASS L 1	TIMR REC
KR 3	OPN/ CLS1	H. DUBB	OPN/ CLS2	REC/ R. M2	CD SRS	L. SP 1	L. PS 2	MODE 2	MODE 1	TIMR PLAY

KEY

SWITCH

A
B
C
D
E

CASSETTE DECK SECTION

WIRING DIAGRAM

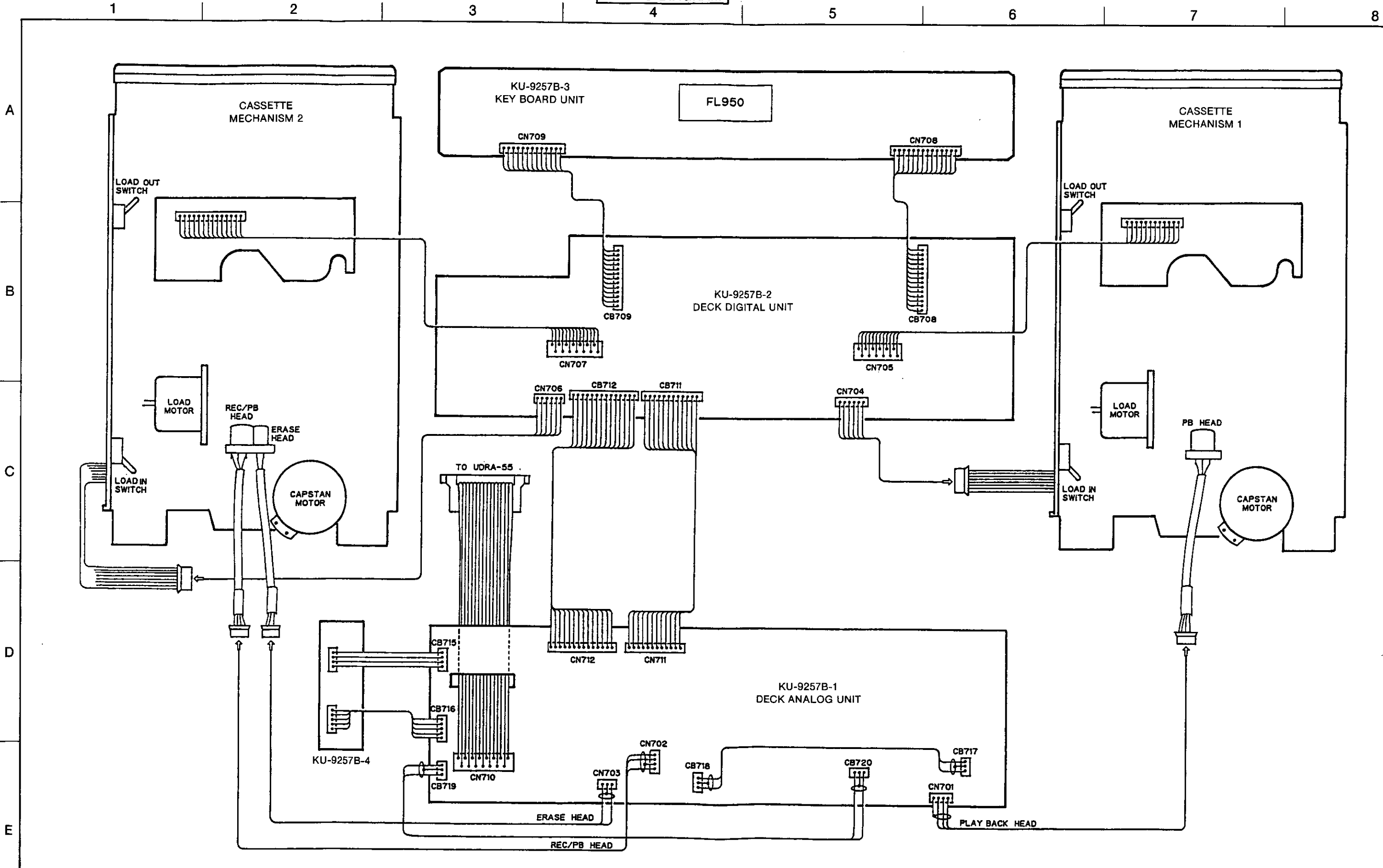

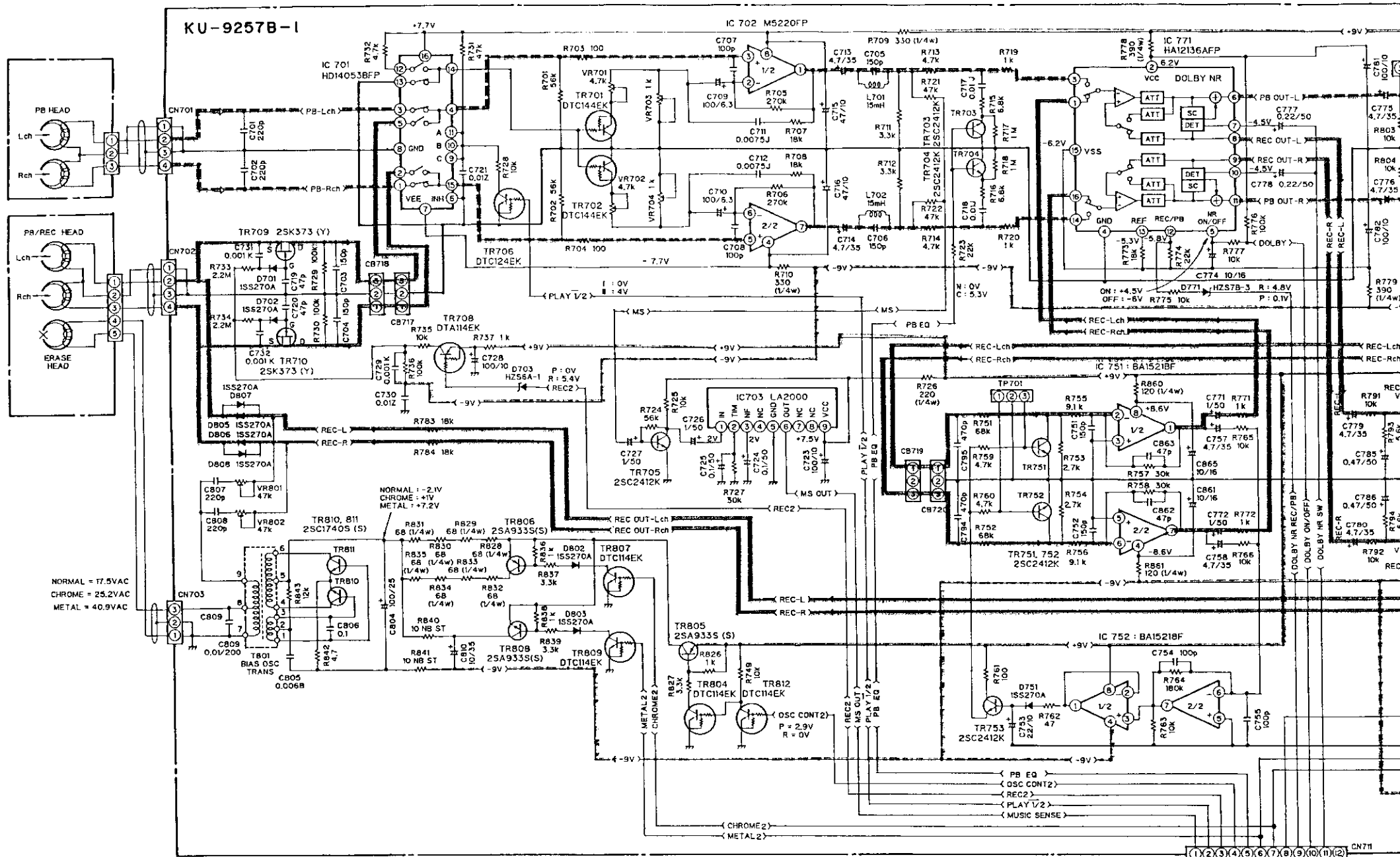

NORMAL = 17.5VAC
 CHROME = 25.2VAC
 METAL = 40.9VAC

- P.B SIGNAL LINE
- REC SIGNAL LINE
- TR LINE
- B LINE
- 11.5V LINE
- +9V LINE
- -9V LINE
- +6V LINE

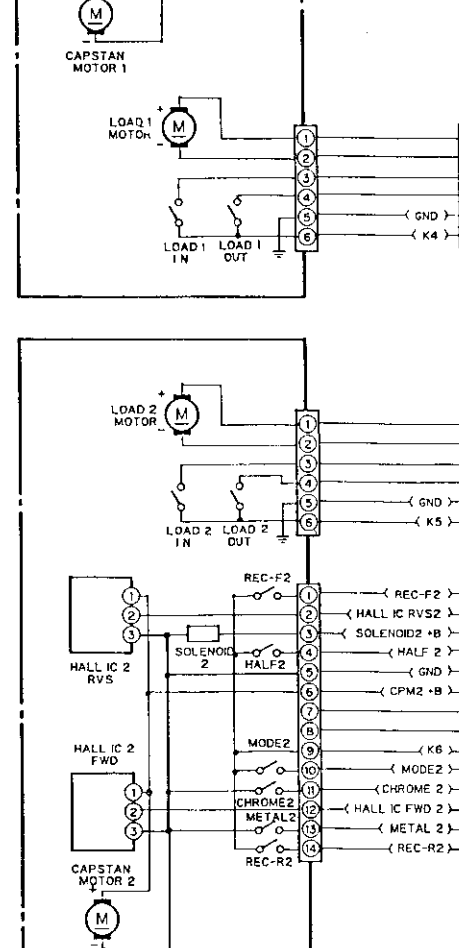
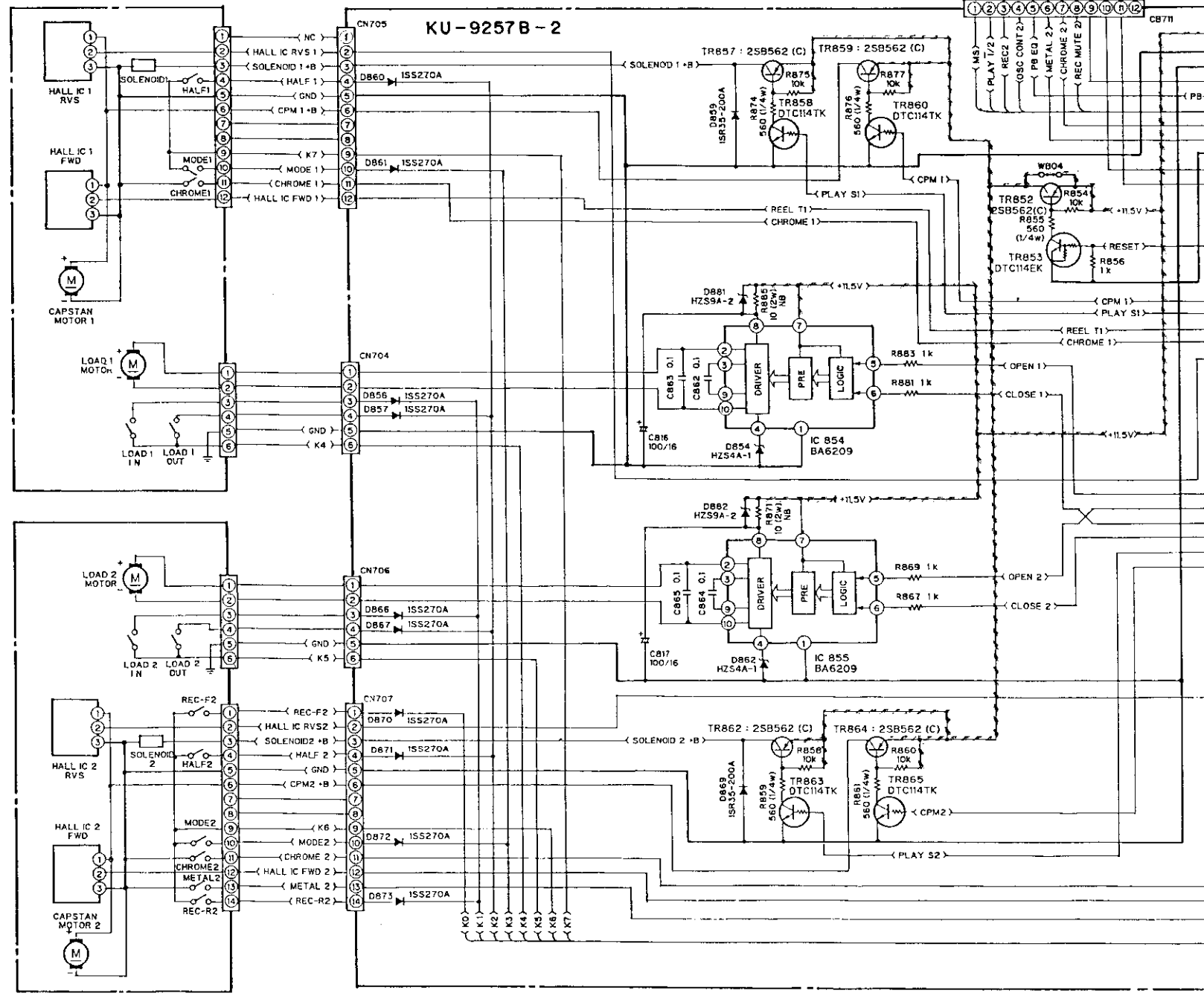

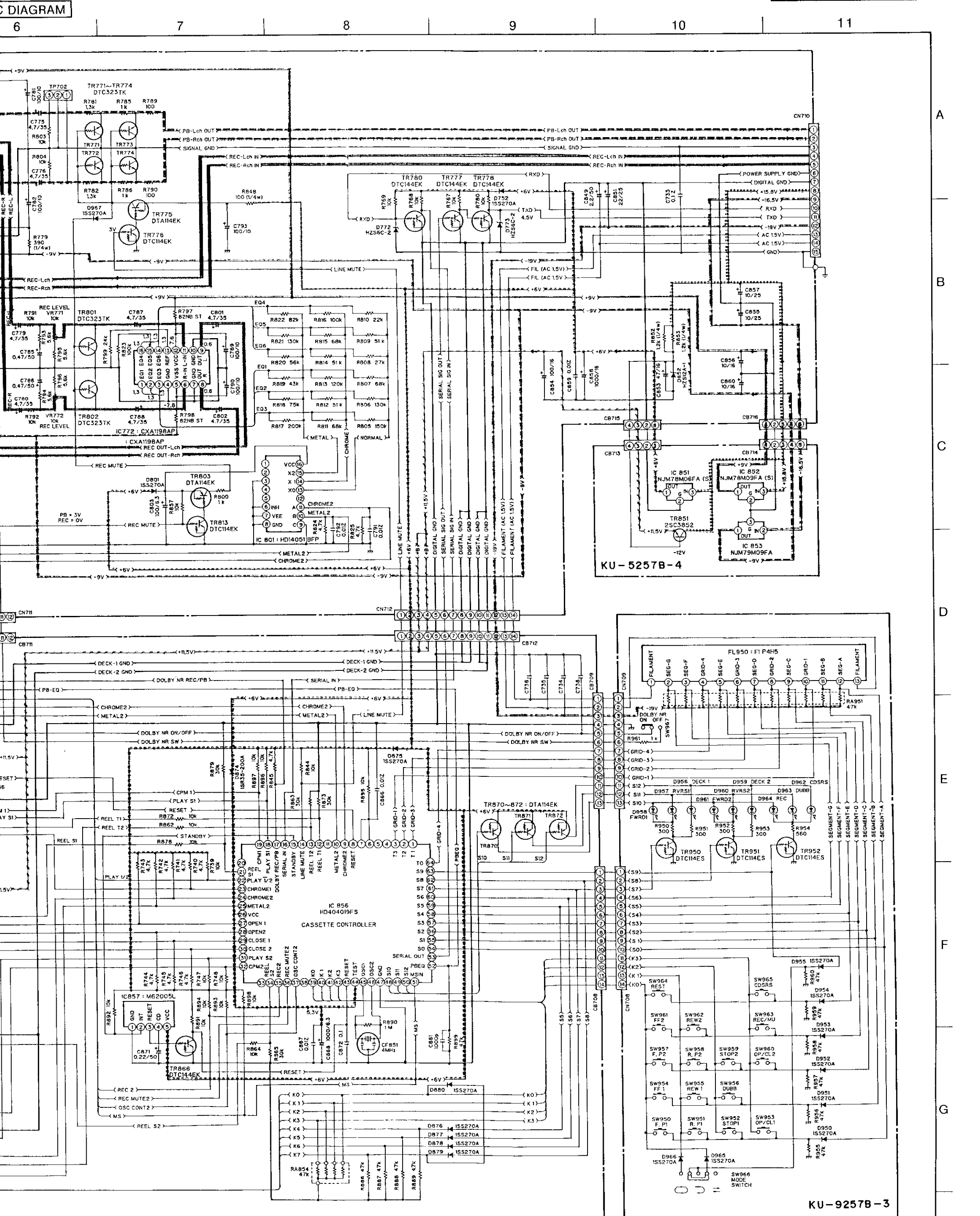

KU-5257B-4

KU-9257B-3

NOTES
 ALL RESISTANCE VALUES IN OHM K=1,000 OHM M=1,000,000 OHM
 ALL CAPACITANCE VALUES IN MICRO FARAD P=MICRO-MICRO FARAD
 EACH VOLTAGE AND CURRENT ARE MEASURED AT NO SIGNAL INPUT CONDITION.
 CIRCUIT AND PARTS ARE SUBJECT TO CHANGE WITHOUT PRIOR NOTICE.

WARNING:
 Parts marked with this symbol Δ have critical characteristics.
 Use ONLY replacement parts recommended by the manufacturer.

A
B
C
D
E
F
G
H

CASSETTE DECK SECTION

PARTS LIST OF UDR-60 EXPLODED

EXPLODED
4

Ref. No.	Part No.	Part Name	Remarks	Qty
1	102 0508 015	Top Cover		1
2	146 1362 111	Loader Panel (L)		1
3	146 1363 110	Loader Panel (R)		2
4	HM 55	Cassette Mecha Unit		1 ^S
5	146 1361 002	Front Panel		1
6	143 0790 002	Window		1
7	143 0787 002	Lens (A)		2
8	143 0788 001	Lens (B)		2
9	143 0789 000	Lens (C)		2
10	113 1512 000	Push Knob (R)		1
11	113 1513 009	Push Knob (L)		1
12	113 1514 008	Slide Knob		2
13	KU- 9257 B-3	Deck Display Unit		1
14	415 0657 008	Insulating Sheet		1
15	411 1160 204	Main Chassis		1
16	KU- 9257 B-2	Deck Unit (Digital)		1
17	124 0079 007	Felt Sheet		2
18	104 0258 002	Foot Assy		2
19	105 1026 333	Rear Panel		1
20	204 6332 057	15P System Conn. Cord BK		1
21	412 3492 106	TR Bracket		1
22	KU- 9257 B-4	Deck Unit (Reg-1)		1
23	KU- 9257 B-1	Deck Unit (Analog)		1
24	412 2741 036	P.W.B Holder H=10		2
25	412 2741 023	P.W.B Holder		2
26	412 2814 028	Card Spacer (L=10)		1
27	412 2814 015	Card Spacer (L=14)		1
28	477 0224 028	SP Washer		2
29	461 0724 002	Spacer		4
30				
31	393 4135 006	FLD (FIP4H5)	1U-2381A	1
32	212 9504 003	Slide Switch	1U-2381A	1
33	212 4423 008	Slide Switch	1U-2381A	1
34	477 0231 024	Washer φ 4 (S)		4
35	477 0224 002	SP Washer		2
36	263 0518 009	IC NJM79M09FA	1U-2380A	1
37	263 0586 002	IC NJM78M06FA	1U-2380A	1
38	263 0517 000	IC NJM78M09FA	1U-2380A	1
39	445 0033 005	Wire Clamp Band		1
SCREWS				
101	473 7002 021	Tapping Screw (S) 3×8	Black	8
102	473 7508 017	Tapping Screw (P) 3×10	Black	8
103	473 7505 007	Tapping Screw (P) 2.6×8		8
104	473 7015 018	Tapping Screw (S) 3×8	Black	4
105	477 0276 018	Earth Screw		1
106	475 2003 034	S. Washer M3 (BK)		1
PACKING & ACCESSORIES (Not included EXPLODED VIEW)				
71	513 1581 008	No. Sheet		1
72	505 0154 082	Cabinet Cover	600×600	1
73	513 1818 108	Unit Sheet		1
74	503 0998 116	Cushion		1
75				

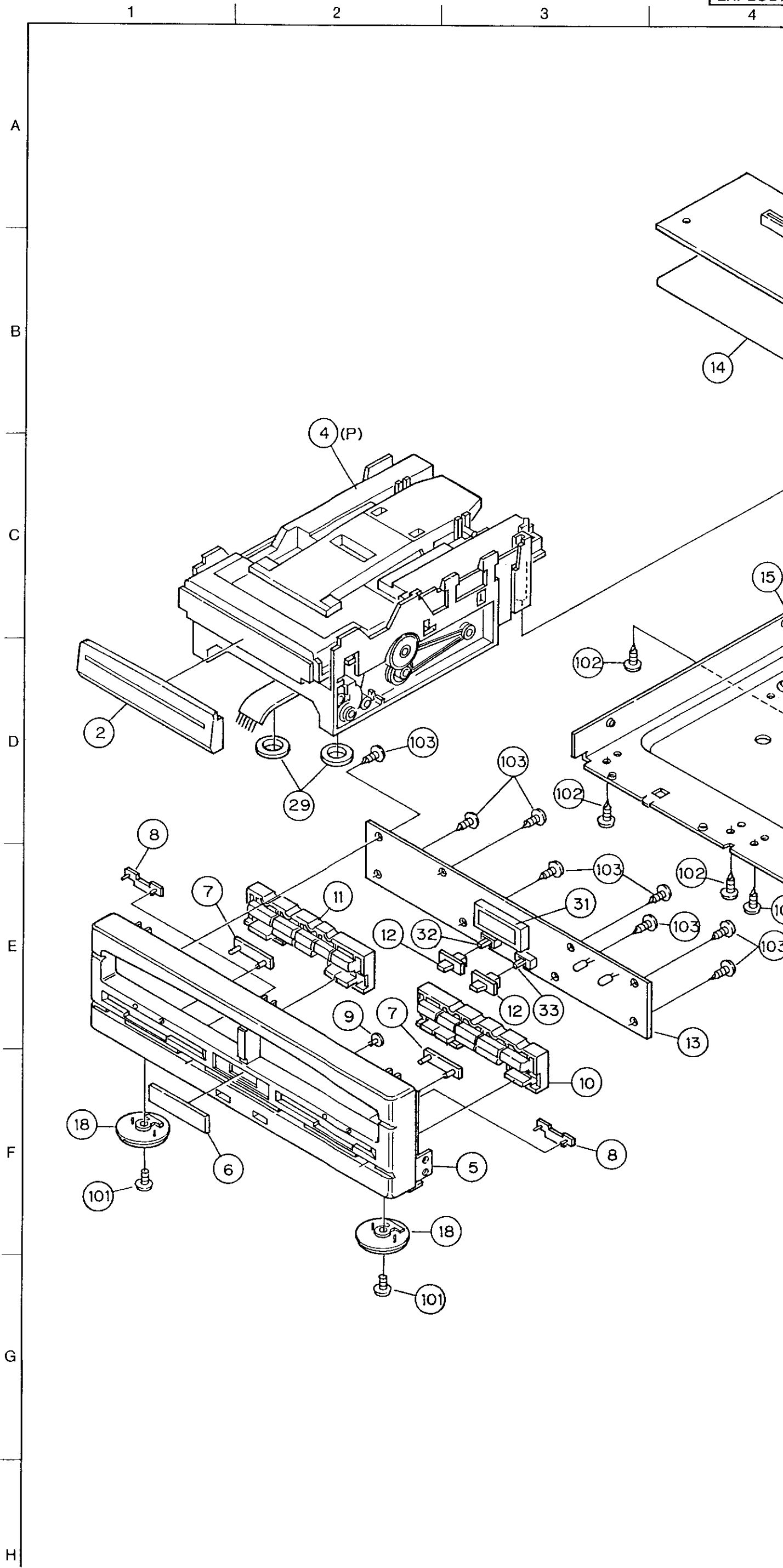

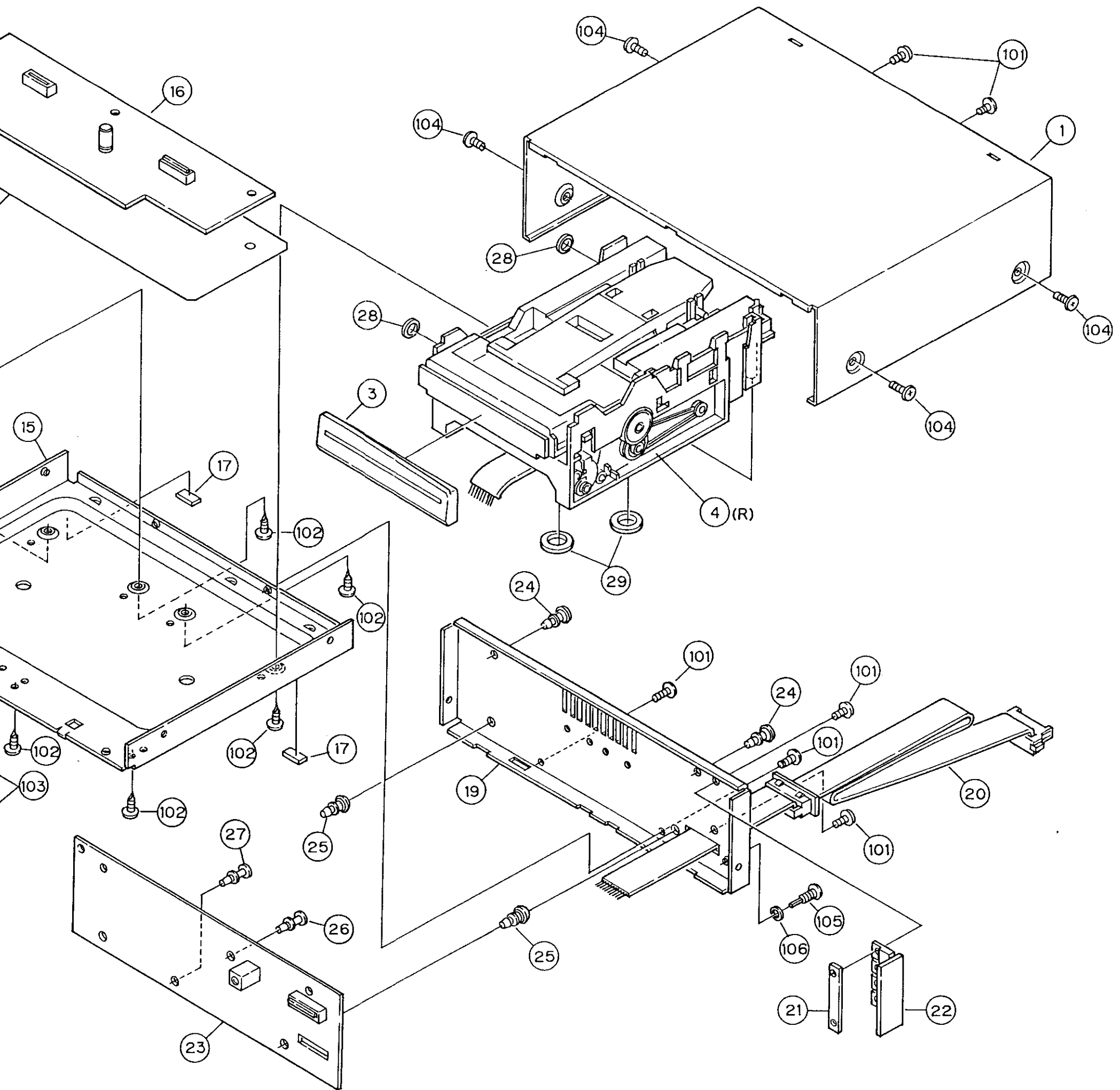

NOTE FOR PARTS LIST

- Part indicated with the mark "●" are not always in stock and possibly to take a long period of time for supplying, or in some case supplying of part may be refused.
- When ordering of part, clearly indicate "1" and "1" (i) to avoid mis-supplying.
- Ordering part without stating its part number can not be supplied.
- Part indicated with the mark "★" is not illustrated in the exploded view.

WARNING:
 Parts marked with this symbol  have critical characteristics.
 Use ONLY replacement parts recommended by the manufacturer.

CASSETTE DECK SECTION

CASSETTE MECHANISM HM-55

HM-55R UNIT PARTS LIST (REC/PB)

HM-55P UNIT PARTS LIST (PB ONLY)

Ref. No.	Part No.	Part Name	Remarks	Q'ty
● 1	411 1163 201	Loading Mecha Ass'y		1
● 2	411 1156 108	Mecha Base Ass'y		1
3	424 0183 000	Pulley Gear		1
4	423 0064 003	Belt		1
5	424 0182 001	Gear		1
6	475 1119 110	Slit Washer		1
7	433 0574 202	Push Lever		1
● 8	412 3467 102	Push Bracket		1
9	463 0708 008	Lever Spring		1
10	463 0709 007	Push Bracket SP.		1
11	433 0573 300	Clamper Arm		1
12	463 0710 106	Clamper SP.		1
13	431 0323 004	Clamper Press		2
14	463 0707 009	Clamper Press SP.		2
15	GEN 1919	Loader F. Sub Ass'y		1
16	217 0158 000	Loading Motor		1
17	421 0379 103	Motor Pulley		1
● 18	338 0151 003	CRF418 C. Mecha REC/PB		1
● 19	412 3468 208	Shield Bracket		1
● 20	412 3518 006	Shield Cover		1
● 21	KU- 9246	P.W. Board Ass'y		1
★ 22	203 8334 005	5P EH-3P4P PH Con. Cord		1
★ 23	203 0240 003	1P Connect Cord		1
24	203 0521 007	Earth Wire Ass'y		1
25	212 1077 004	Micro Slide SW		2
26	475 1161 003	Washer		1
27	477 0224 028	SP Washer		2
28	-	-		-
SCREWS				
51	473 8044 004	Special Screw		4
52	471 3201 011	Bind Screw 2.6×4		2
53	473 7002 005	Tapping Screw (P) 3×6		2
54	473 7500 015	Tapping Screw (P) 3×8		6

Ref. No.	Part No.	Part Name	Remarks	Q'ty
● 1	411 1163 201	Loading Mecha Ass'y		1
● 2	411 1156 108	Mecha Base Ass'y		1
3	424 0183 000	Pulley Gear		1
4	423 0064 003	Belt		1
5	424 0182 001	Gear		1
6	475 1119 110	Slit Washer		1
7	433 0574 202	Push Lever		1
● 8	412 3467 102	Push Bracket		1
9	463 0708 008	Lever Spring		1
10	463 0709 007	Push Bracket SP.		1
11	433 0573 300	Clamper Arm		1
12	463 0710 106	Clamper SP.		1
13	431 0323 004	Clamper Press		2
14	463 0707 009	Clamper Press SP.		2
15	GEN 1919	Loader F. Sub Ass'y		1
16	217 0158 000	Loading Motor		1
17	421 0379 103	Motor Pulley		1
● 18	338 0152 002	CRF419 C. Mecha PB		1
● 19	-	-		-
● 20	412 3518 006	Shield Cover		1
● 21	KU- 9246	P.W. Board Ass'y		1
★ 22	203 4856 008	3P EH-4P PH Con. Cord		1
★ 23	203 0240 003	1P Connect Cord		1
24	-	-		-
25	212 1077 004	Micro Slide SW		2
26	475 1161 003	Washer		1
27	-	-		-
● 28	412 3517 104	Shield Ring		1
SCREWS				
51	473 8044 004	Special Screw		4
52	471 3201 011	Bind Screw 2.6×4		2
53	-	-		-
54	473 7500 015	Tapping Screw (P) 3×8		6

P.W.B UNIT ASS'Y

Component Side

Pattern Side

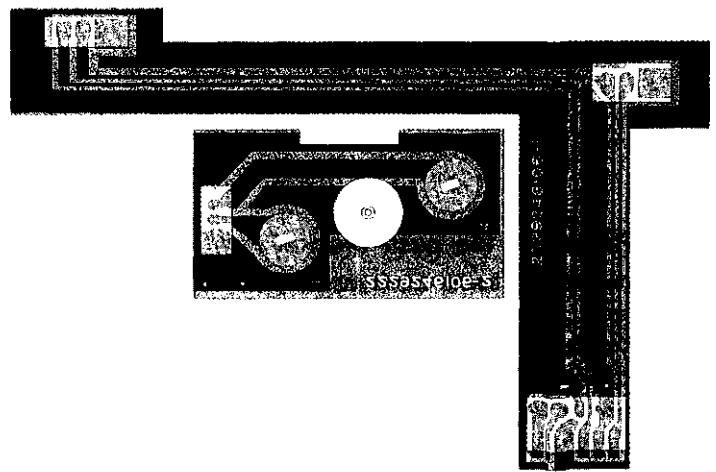
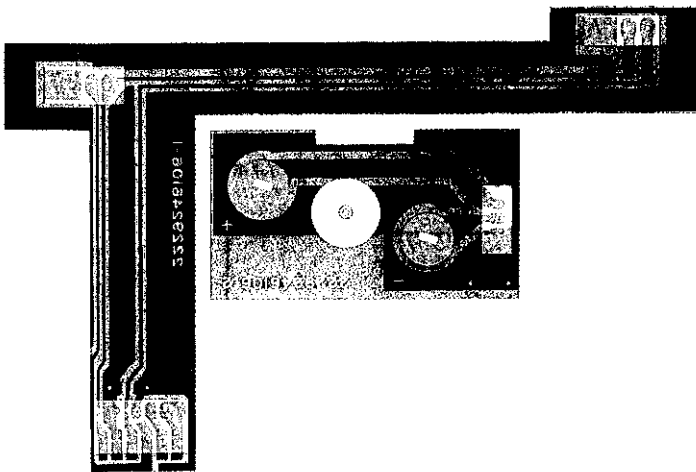

P.W.B. UNIT ASS'Y PARTS LIST

Ref. No.	Part No.	Part Name	Remarks	Q'ty
OTHER GROUP				
	-	(P.W. Board)		(1)
	205 0355 062	6P KR Con Base (L)		1
	209 0008 146	Jumper (L=5)		2
	205 0409 031	3P DIP Socket		2
	002 0042 006	3C R. Wire Ass'y		1
	212 1077 004	Micro Slide Switch		2
	475 1161 003	Washer		1

CASSETTE DECK SECTION

DISASSEMBLY PROCEDURES

(Follow these procedures in reverse order to reassemble.)

1. Removing the loader frame assembly

- ① Pull the loader frame assembly out forwards until it stops.
- ② Insert a screwdriver with a narrow tip into the section indicated with the arrow, then lift the hook and pull the loader frame assembly out forwards.

NOTE: When reinserting the loader frame assembly, be careful not to damage the micro slide switch.

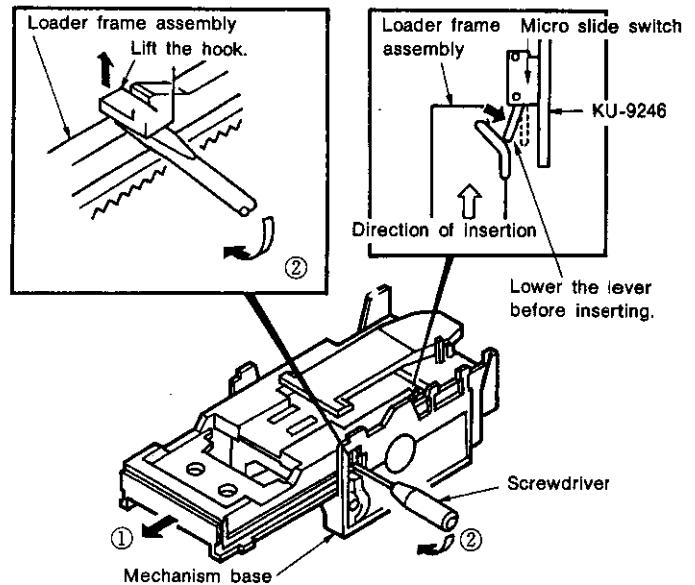

2. Removing the cassette mechanism

- ③ Remove the shield cover screw, then remove the shield cover.
- ④ Remove the five screws fastening the cassette mechanism.
- ⑤ Pressing the push bracket in the direction of the arrow...
- ⑥ ...lift the cassette mechanism up and off.

NOTE: The push bracket may be deformed if the cassette mechanism is lifted without pressing the push bracket in the direction of the arrow. (The same is true when reassembling.) A deformed push bracket cannot be used. After fastening the cassette mechanism with the screws, check that the push bracket moves (rotates) properly.

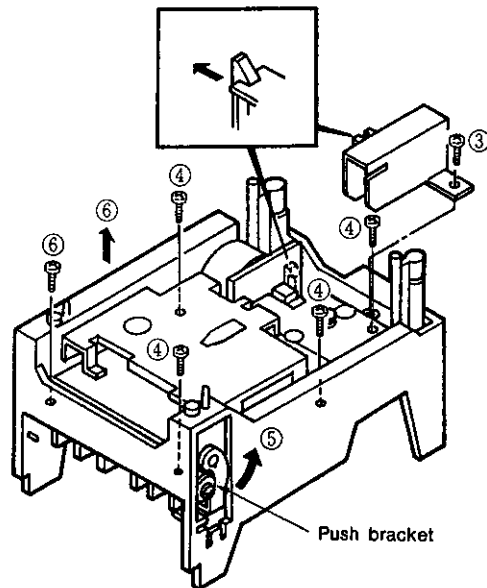

3. Removing the push bracket

Do this with the loader frame assembly and cassette mechanism removed.

- ⑦ Remove the two special screws.
- ⑧ Remove the lever spring.
- ⑨ Remove the push bracket spring using a spring catching rod, etc., through hole A.
- ⑩ Remove the push bracket.
 - (a) Disconnect first the left then the right push bracket bar ring from the mechanism base's push bracket boss.
 - (b) Bring out first the left then the right side from the mechanism base's push bracket insertion slot.

NOTE: Be careful not to deform the push bracket (do not forcibly disassemble or assemble it). A deformed push bracket cannot be used.

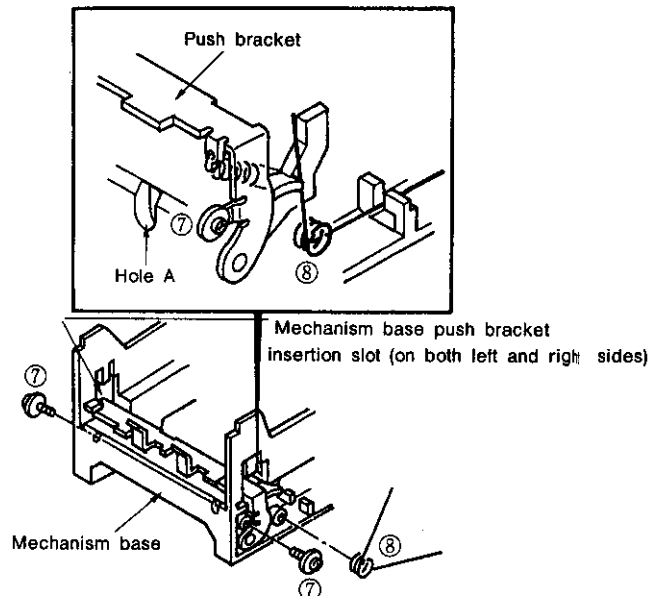

CASSETTE DECK SECTION

1 2 3 4 5 6 7 8

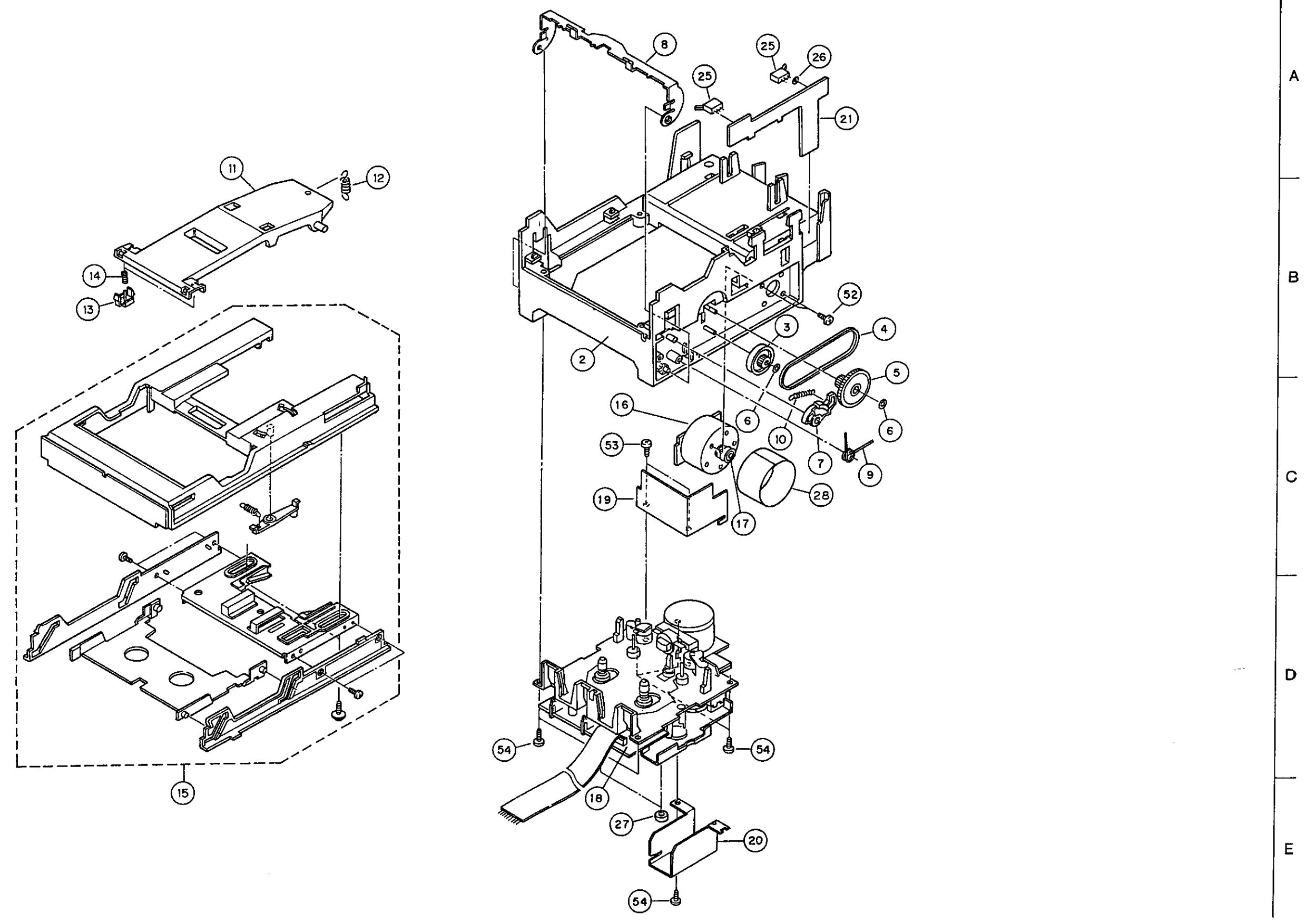

CASSETTE DECK SECTION

EXPLODED VIEW (REC/PB)

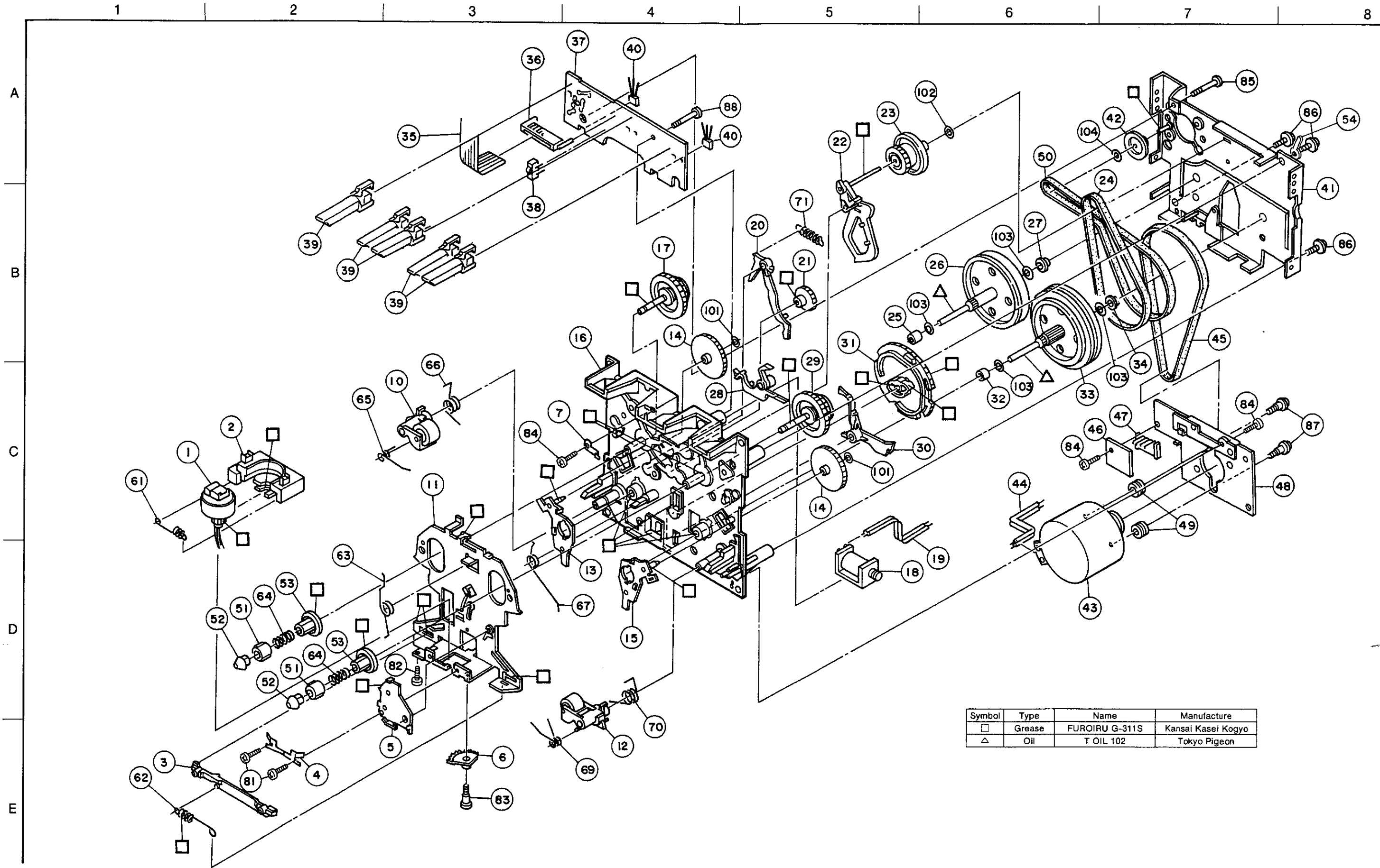

Symbol	Type	Name	Manufacture
□	Grease	FUROIURU G-311S	Kansai Kasei Kogyo
△	Oil	T OIL 102	Tokyo Pigeon

CASSETTE DECK SECTION

EXPLODED VIEW (PB ONLY)

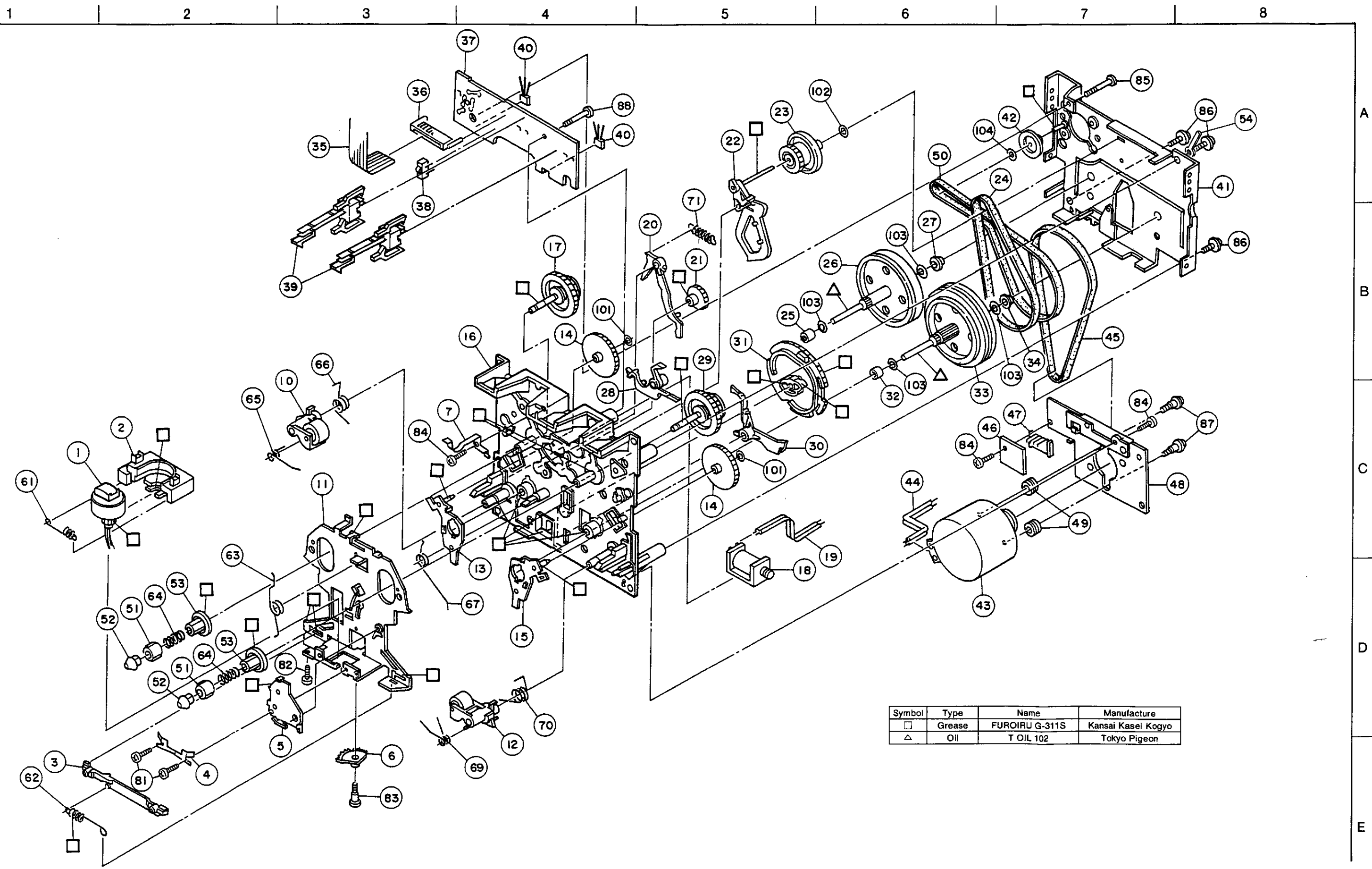

Symbol	Type	Name	Manufacture
□	Grease	FUOIRU G-311S	Kansai Kasei Kogyo
△	Oil	T OIL 102	Tokyo Pigeon

CASSETTE DECK SECTION

PARTS LIST OF CASSETTE MECHANISM (REC/PB) Parts No. 3380151003

Table with columns: Ref. No., Part No., Part Name, Remarks, Q'ty. Lists parts for cassette mechanism (REC/PB) including Ass'y Holder Head, Frame Head, Lever Head, Spring Azimuth, Ass'y Arm Assist, Gear Arm Head, Plate Stopper, Ass'y Pinch Arm L, Chassis Head, Ass'y Pinch Arm R, Ass'y Arm Play L, Gear Play, Ass'y Arm Play R, Chassis OS, Ass'y Sub Reel L, Solenoid, Wire, Arm RVS, Gear FF, Ass'y Arm FR, Ass'y Pulley FR, Belt FR, Metal, Ass'y Flywheel L, Metal, Arm Brake, Ass'y Sub Reel R, Arm Triger, Gear Cam, Metal, Ass'y Flywheel R, Metal, Wire (14P), Holder Wire, P.W.Board, Switch Mode, Switch (Leaf), Hall IC, Bracket FW, Pulley, Ass'y Moter, Wire, Belt Main, P.W.Board, Housing, Bracket Motor, Rubber Cushion, Belt, Reel A, Reel B, Pulley Reel, Keep Wire, and various Springs.

PARTS LIST OF CASSETTE MECHANISM (PB ONLY) Part No. 3380152002

Table with columns: Ref. No., Part No., Part Name, Remarks, Q'ty. Lists parts for cassette mechanism (PB ONLY) including Ass'y Holder Head, Frame Head, Lever Head, Spring Azimuth, Ass'y Arm Assist, Gear Arm Head, Plate Stopper, Ass'y Pinch Arm L, Chassis Head, Ass'y Pinch Arm R, Ass'y Arm Play L, Gear Play, Ass'y Arm Play R, Chassis OS, Ass'y Sub Reel L, Solenoid, Wire, Arm RVS, Gear FF, Ass'y Arm FR, Ass'y Pulley FR, Belt FR, Metal, Ass'y Flywheel L, Metal, Arm Brake, Ass'y Sub Reel R, Arm Triger, Gear Cam, Metal, Ass'y Flywheel R, Metal, Wire (12P), Holder Wire, P.W.Board, Switch Mode, Switch (Leaf), Hall IC, LB9051A, Bracket FW, Pulley, Ass'y Moter, Wire, Belt Main, P.W.Board, Housing, Bracket Motor, Rubber Cushion, Belt, Reel A, Reel B, Pulley Reel, Keep Wire, and various Springs.

DISASSEMBLY PROCEDURES

(Follow these procedures in reverse order to reassemble.)

1. Removing the top cover and front panel

- ① Remove the six screws fastening the top cover.
- ② Lift the top cover in the direction of the arrow. The top cover is caught in the three ribs in the front panel, so lift it straight upwards.

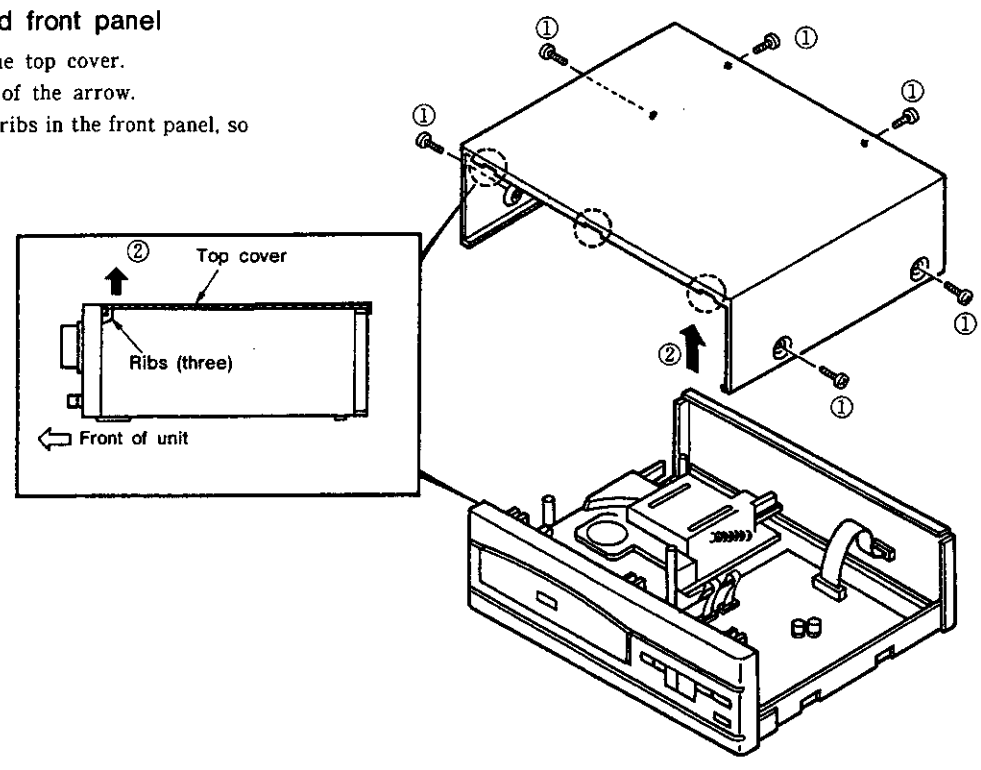

- ③ Set the unit up as shown in the diagram, then remove the two screws fastening the foot assembly.
- ④ Unlatch the hook of the front panel from the chassis and remove the front panel in the direction of the arrow.

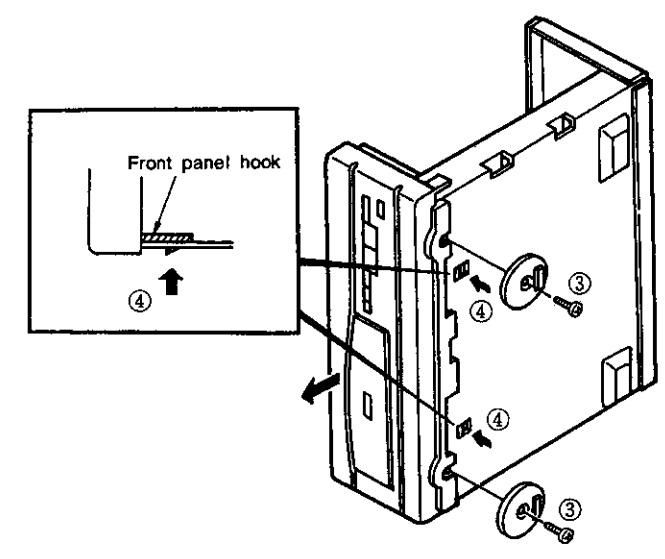

2. Removing the printed wiring boards

CD SWITCH UNIT KU-9258B-4

- ① Remove the three screws fastening the CD switch unit, then remove the printed wiring board in the direction arrow.

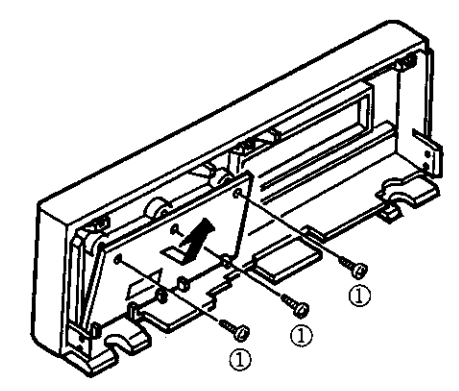

CD UNIT KU-9258B-3

- ① Remove the two screws fastening the CD unit.
- ② Pressing on the two mechanism holder hooks fastening the CD unit, lift the printed wiring board up in the direction of the arrow.
- ③ Pressing down on the locking section of the connector, disconnect the wires in the direction of the arrow.

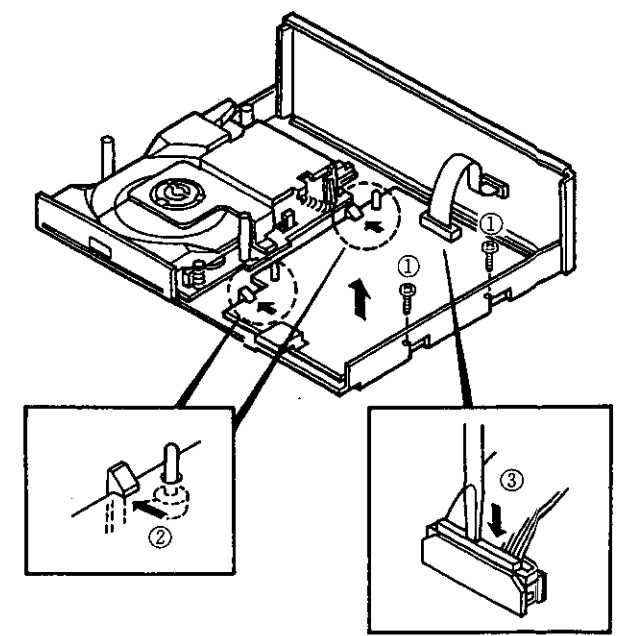

CD MECHANISM UNIT

- ① Remove the three screws fastening the CD mechanism unit. Disconnect the connectors connecting the mechanism and CD unit.

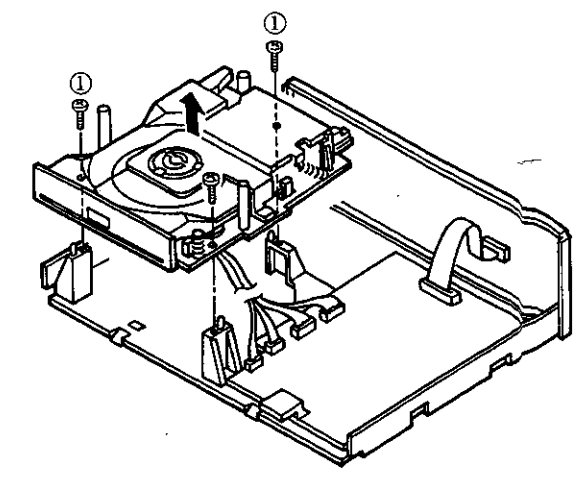

BLOCK DIAGRAM

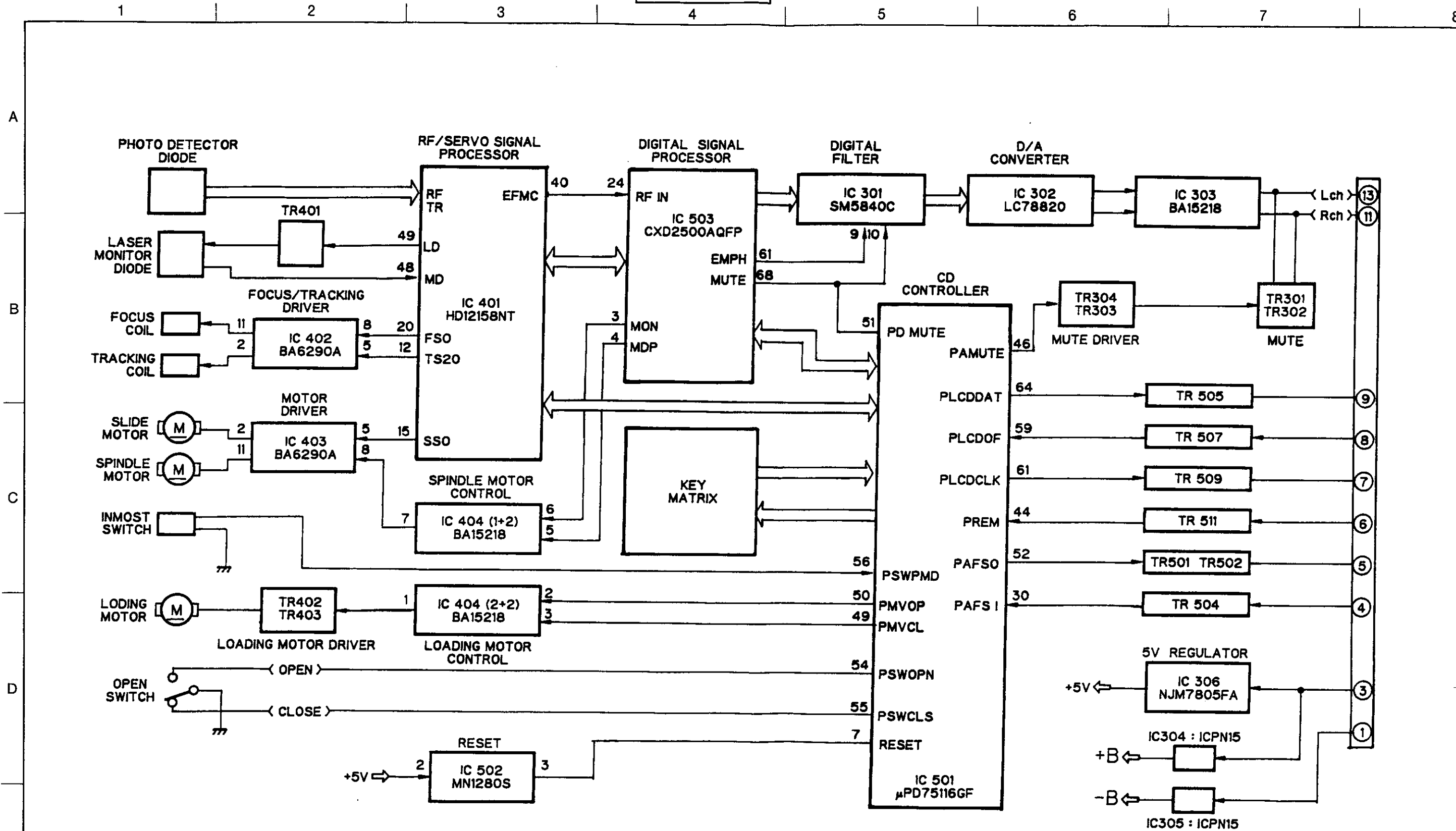

LASER PICKUP

Connections Diagram

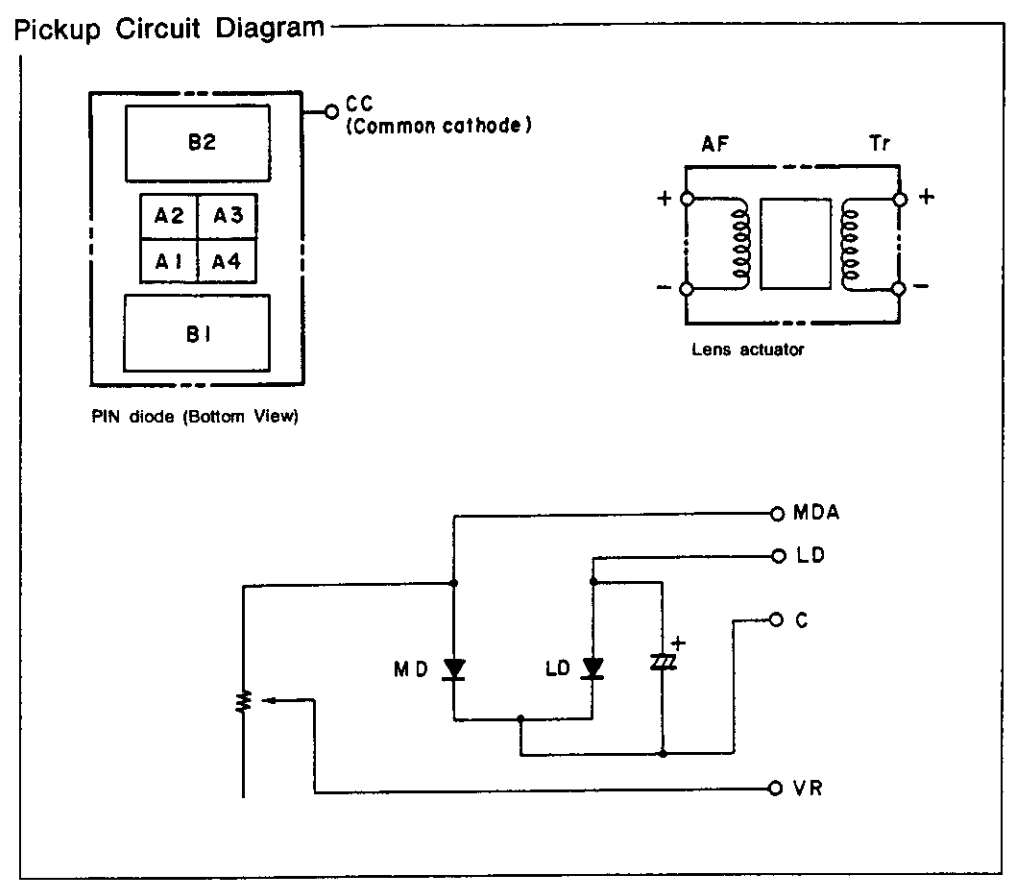

Laser Drive Basic Circuit Diagram

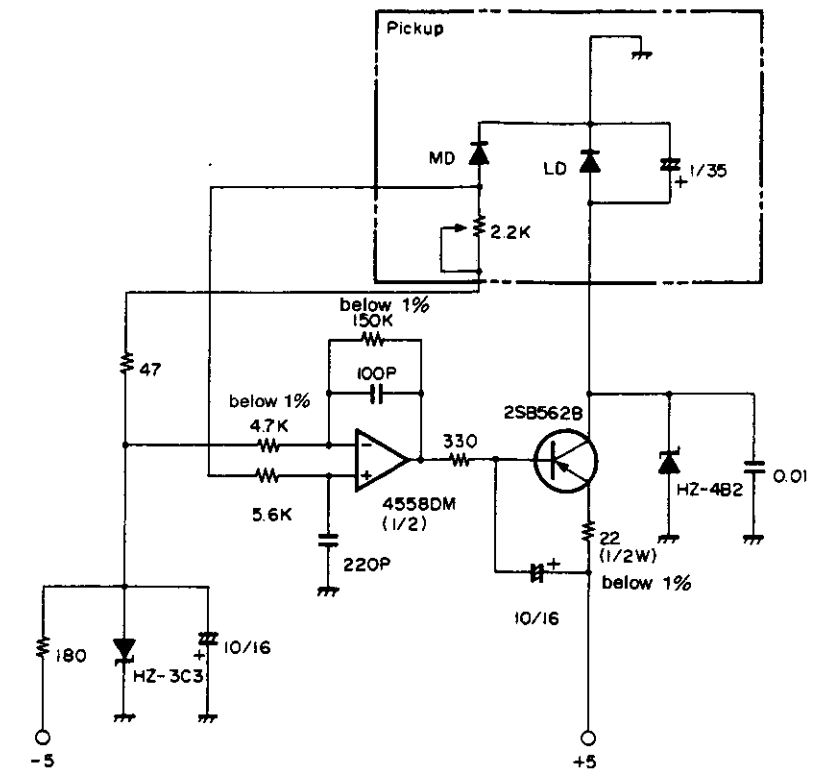

Measurement Circuit Diagram

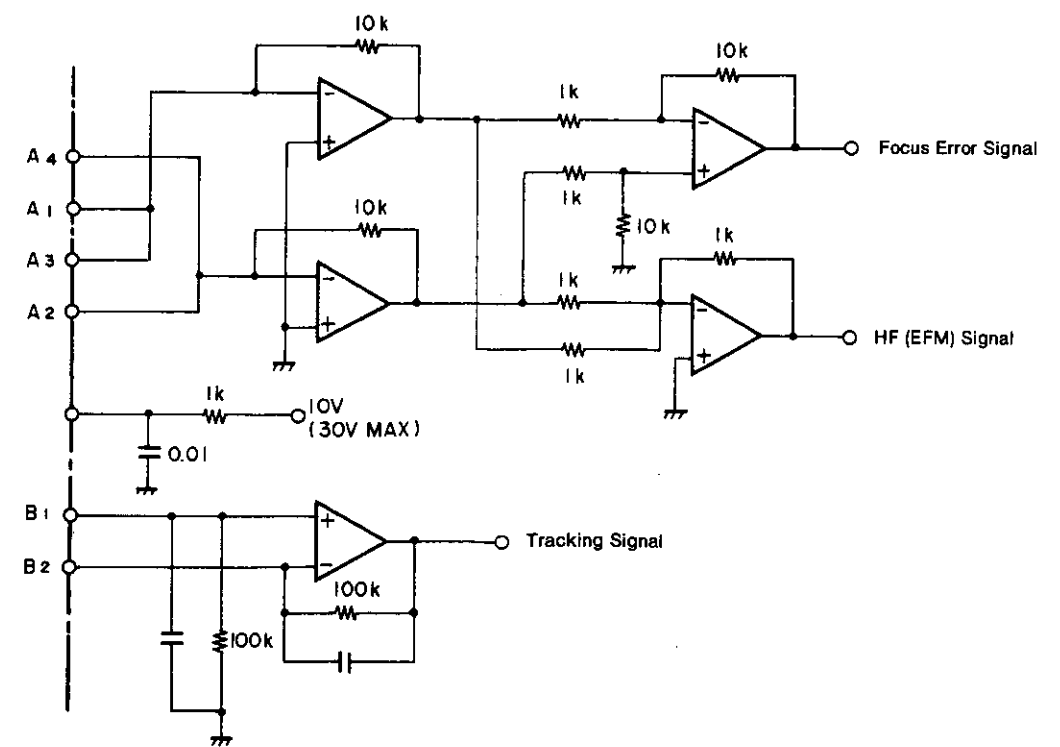

1. PD connector

PH pin post 7 pins (Type number B7B-PH-K-S manufactured by Nippon Atchaku Tanshi Hanbai K.K.)

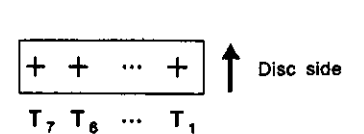

Tn	1	2	3	4	5	6	7
Item	A ₃	A ₄	A ₂	A ₁	CC	B ₁	B ₂

2. LD actuator connector

PH pin post 8 pins (Type number B8B-PH-K-S manufactured by Nippon Atchaku Tanshi Hanbai K.K.)

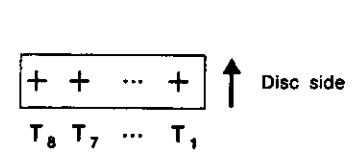

Tn	1	2	3	4	5	6	7	8
Item	C	LD	MDA	VR	TR+	TR-	AF-	AF+

CD SECTION

● Precautions in Use

Read the following carefully before handling.

1. Laser control circuit

The light output of the laser diode (LD) is greatly affected by temperature, so a built-in monitor photodiode should be used in the LD to supplement the light output.

In order to get rid of the dispersion of the monitor photodiode, the semiconductor resistor accompanying the pickup has been adjusted so that the mirror surface level of the HF signal becomes 250 mV when the measurement circuit of this manual and the basic laser drive circuit are used. When designing a new laser drive circuit, note that the life of the laser will be shortened when the mirror level of the HF signal becomes 275 mV with this measuring circuit.

2. Wiring

Be sure to use the specified connectors for the wiring.

Note that the eye pattern may deteriorate when there is a microprocessor or other digital noise source in the vicinity from the photodiode to the harness.

Note that a poor connection related to the LD and actuator connector will cause deterioration of the laser, and so there should not be any looseness of connectors.

● Precautions in Handling

This mechanism has been precisely assembled and adjusted at a special factory. It should not be disassembled or adjusted without good reason. Pay attention to the following points related to handling.

1. General items

(1) Storage

Avoid storage in places with high temperatures and high humidity, and in places exposed to a lot of dust.

(2) Handling

The unit has been precisely adjusted and care should be taken so as not to expose the unit to shocks through dropping or careless handling.

2. Semiconductor laser (LD)

(1) Protection of the eyes from the laser

The output of the LD is via an objective lens and is a maximum of 400 μ W, but reaches approximately 1.3×10^4 W/cm² in places where there is condensed light. After being condensed by the objective lens, the beam widens and so is all right at a distance of 30 cm or further, but during operation the LD should never be allowed to be viewed directly or through another lens or mirror since this is dangerous.

(2) Destruction by surge currents or static electricity

When a large current flows through the LD, even for a very short period, the strong light which the LD generates itself will advance the deterioration of the LD or destroy it.

Wire a switch into the LD drive circuit or provide another method of preventing the flow of surge currents. Also, when handled without care, the LD can be destroyed instantly by the application of static electricity from the body. Therefore, when handling the LD, be sure to ground your body and ground the measuring instruments, jigs, and tools. It is also desirable to use a grounding mat on the work bench and floor.

3. Lens actuator

(1) The actuator section uses a strong magnetic circuit, so that when magnetic bodies come too close, their characteristics are altered.

Also be careful not to allow foreign matter to enter from the cover gap.

(2) Lens cleaning

Dust or dirt adhering to the objective lens will change the performance.

To clean, blow the dirt away with clean air from an air blower.

4. Handling

Be sure not to contact the lens when handling the LD.

Note that direct contact of the body or other objects with the circuit of the LD board will cause deterioration to occur, so sufficient care should be taken.

SERVICE POINTS

1. Parts replacement of the tray mechanism (Figs. 1 and 2)

(1) Removal of the tray

Open the tray and use a flat-bladed screwdriver to press the stopper portions of Fig. 1 (one each in the left and right locations) in the direction of the black arrow, then remove in the direction of the white arrow.

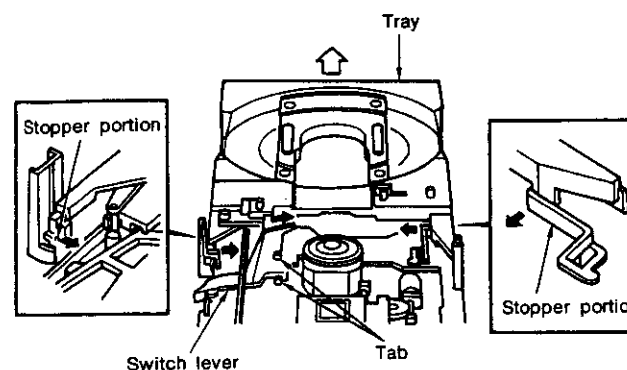

Fig. 1

(2) Mounting of the tray (Figs. 1, 2, and 3)

Rotate the switch lever in the direction of the arrow, set the latches of the tray as illustrated in Fig. 2, then align the rails of the tray in the grooves of the loading plate, and insert so that the pinch lever pins of the switch lever enter into the rack grooves. Push in the tray while pressing the stopper portion inside a little.

(Check that the latches are in the positions illustrated in Fig. 2.)

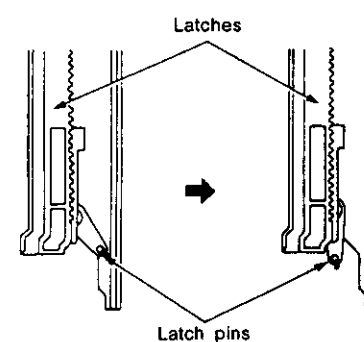

Fig. 2

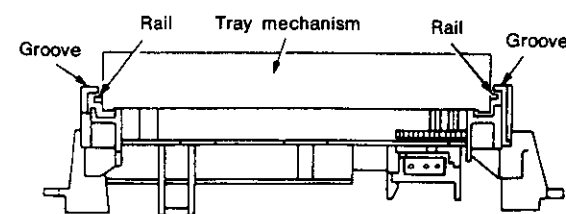

Fig. 3

(3) Replacement of the disc holder (Fig. 4)

With the tray removed, remove tabs D and E of the disc receptacle of Fig. 4, then lift up and off.

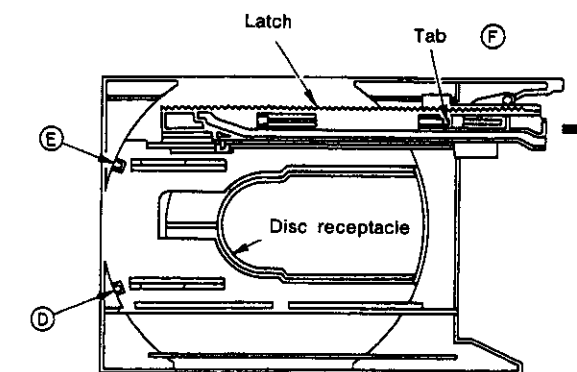

Fig. 4

(4) Replacement of the latches (Fig. 4)

Set the latches into the condition of Fig. 4, lift the latch tab (F) up about 1 mm with a flat-bladed screwdriver and remove the rack in the direction of the arrow.

(5) Removal of the loading motor and switches (Fig. 5)

Remove the belt from the loading motor, then remove the 3 tabs. Remove the fixed tabs from the various switches.

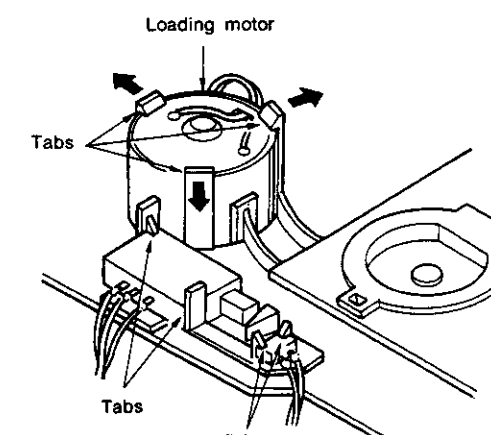

Fig. 5

(6) Replacement of the belt

Replace the belt with the tray removed.

(7) Replacement of the clamber (Fig. 6)

Hook the elongated holes of the clamber onto the C arm, bend the elongated hole sections and attach.

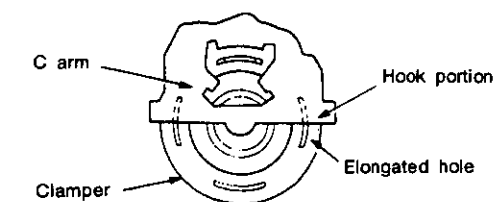

Fig. 6

(8) Replacement of the switch lever (Fig. 1)

Remove the tabs of the bottom side (in 2 locations).

2. Removal of the unit mechanism (Fig. 7)

After removing the loading mechanism, remove the tab of the bottom surface (in one location) as illustrated in Fig. 7.

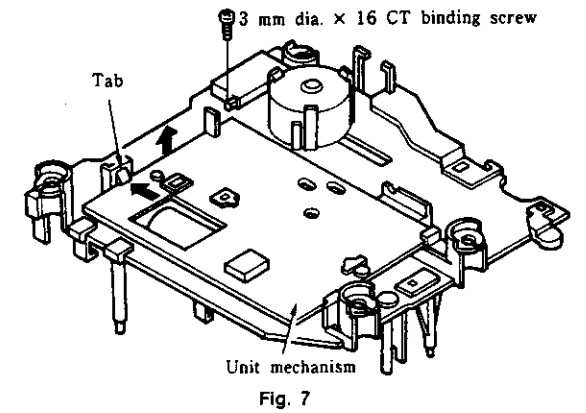

(1) To replace the DC motor (D2) and the turntable, follow the procedure below

- 1) Pull the turntable (plastic) off vertically from the unit plate.
 - 2) When fitting on the servicing turntable (metal), make a height adjustment. (Fig. 8)
- Do not exert excessive force to the shaft of the DC motor (D2) at this time.

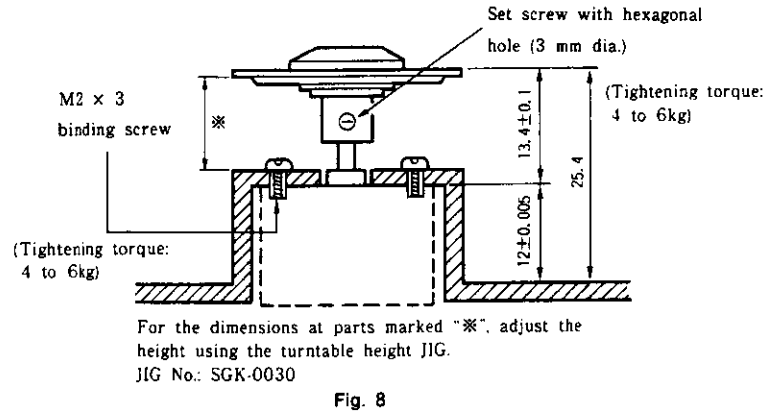

3) At the time of service replacement of the DC motor (D2), do not apply excessive force in direction B. When part C of the unit plate is misshapen, it will cause eye pattern deterioration. (Fig. 9)

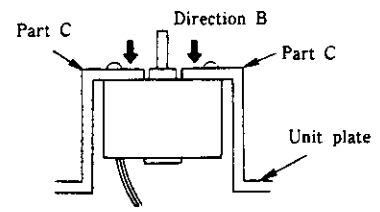

Fig. 9

NOTE:

- Motor replacement or turntable replacement method
Remove the pressure-fitted turntable, and remove the motor screws.
- Do not reuse a turntable (plastic) that has been removed once.

(2) When disassembling and assembling the unit mechanism, assemble with wiring resembling that of Fig. 10

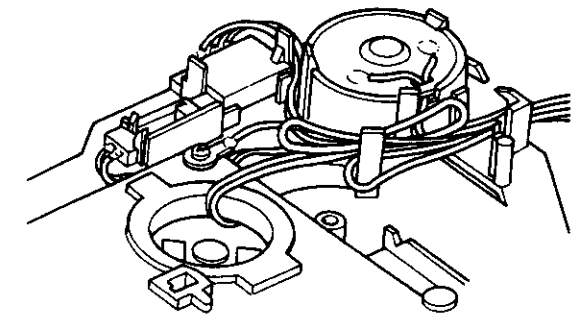

Fig. 10

3. Inspection of the objective lens (Fig. 11)

Handle so as not to get dirt or dust on the objective lens of the lens actuator section. Note that when used for a long period, dirt or dust may have adhered to the objective lens. Try cleaning the surface of the objective lens with a dry, clean cotton swab. If the dirt still does not come off, moisten the cotton swab with a small amount of water and wipe. When doing this, be careful not to get water on any parts other than the lens.

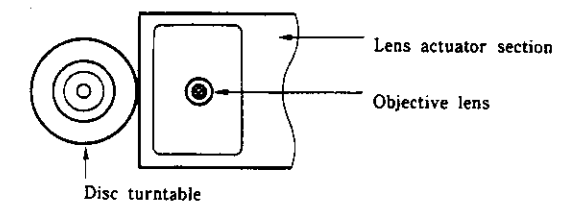

Fig. 11

4. Inspection for laser breakdown

The laser is normally driven with a current of 30 to 80 mA. If this laser drive current value is measured at 120 mA or higher in the circuit, the laser may be thought to be faulty. (The current value is measured by taking the voltage (0.99 to 3.3 V) across both ends of R401, which is 33 ohms).

5. Precautions at time of servicing (Fig. 12)

(1) Semiconductor laser

The semiconductor laser is very susceptible to static electricity destruction and surge currents. Be careful never to touch the terminals of the semiconductor laser and the terminals of the flexible board with your hands or a tool. As illustrated in Fig. 12, the current and light intensity characteristics increase abruptly once the threshold current value is exceeded.

Also note that this threshold current differs a little from laser to laser. In view of this, when replacing the unit mechanism or any work that involves setting the amount of light of the laser, be sure to turn the adjustment control VR401 fully in the counterclockwise direction, and then raise it to the specified value.

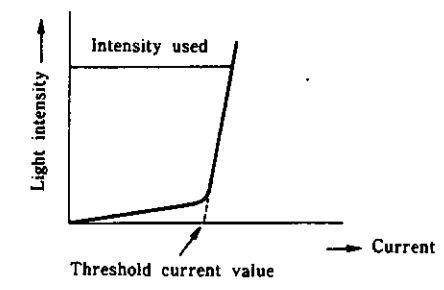

Fig. 12

(2) Handling the unit mechanism (Fig. 13)

When handling the pickup mechanism and the unit mechanism, use a ground ring such as the one illustrated in Fig. 13. (A ground ring can be constructed using ordinary lead wire.)

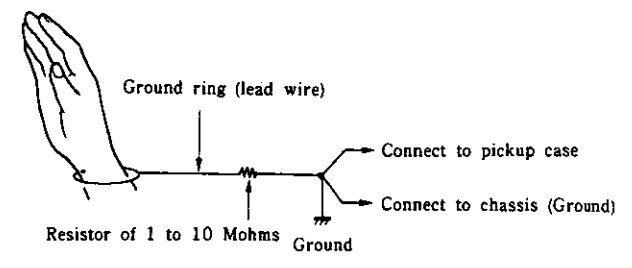

Fig. 13

6. Inspection of the actuator (Fig. 14)

Check the resistance value of the actuator coil. It is normal if the values are as follows:

- Focusing coil 30 ohms
- Tracking coil 10 ohms

If the coils are open or shorted, the actuator may be thought to be broken. Also, a 1.5 V battery can be used to observe if the lens moves.

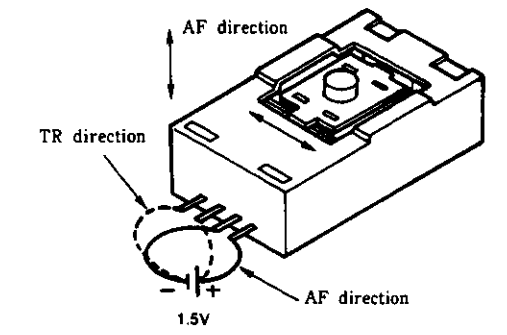

Fig. 14

CD SECTION

ADJUSTMENT METHOD

The microprocessor contained in this unit incorporates a service program which allows a wide variety of service adjustments to be conducted easily by using the operation buttons.

1. Method of starting the service program

Switch on the AC power while simultaneously pressing the ▶ PLAY switch and the ▲ OPEN/CLOSE switch of the CD unit (UCD-60). After doing this, release your hand from the switches and press the STANDBY (POWER) switch of the receiver unit (UDRA-60). When all power has been switched on there will be a transition to the service program. At this time the display section of the receiver unit (UDRA-60) display tube will indicate "01".

2. Operation functions when the service program is operating

Operation button	Operation function	Description
▲ OPEN/CLOSE	Opens and closes the disc holder.	<ul style="list-style-type: none"> ● Opening and closing takes place when the rotation of the disc has stopped. ● Other operation buttons are performed when the opening and closing operation is completed.
■ STOP	Stops system operation.	<ul style="list-style-type: none"> ● Track number display becomes 01. ● Press when an adjustment has been completed or is redone.
▶ PLAY	Operates the focus servo and rotates the disc.	<ul style="list-style-type: none"> ● Press at the time of the tracking offset adjustment. ● After the operation is completed, the track number display becomes 02.
⏸ PAUSE	Operates the focus servo, tracking servo, slide servo, and the spindle servo.	<ul style="list-style-type: none"> ● When the play button has been pressed, the tracking servo and slide servo are operated. ● After the operation is completed the track number display becomes 03.
Other buttons	Operation is not normal.	<ul style="list-style-type: none"> ● Do not operate buttons other than the above. ● When a button is operated by mistake, immediately turn the power switch off.

NOTE: Do not use the remote control while the service program is operating.

3. Adjustment method

(1) Measuring instruments required in the adjustment

- ① Dual-trace oscilloscope
- ② Oscilloscope

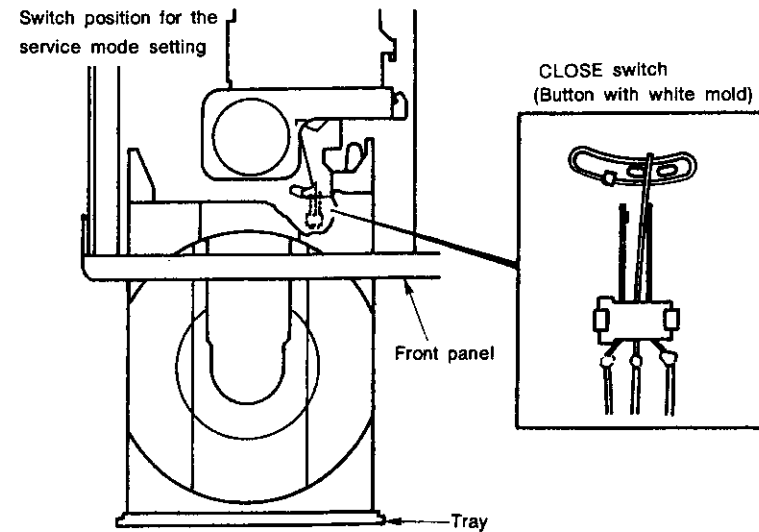

OUTLINE DIAGRAM OF ADJUSTMENT LOCATIONS

KU-9258B-3 CD UNIT ASS'Y

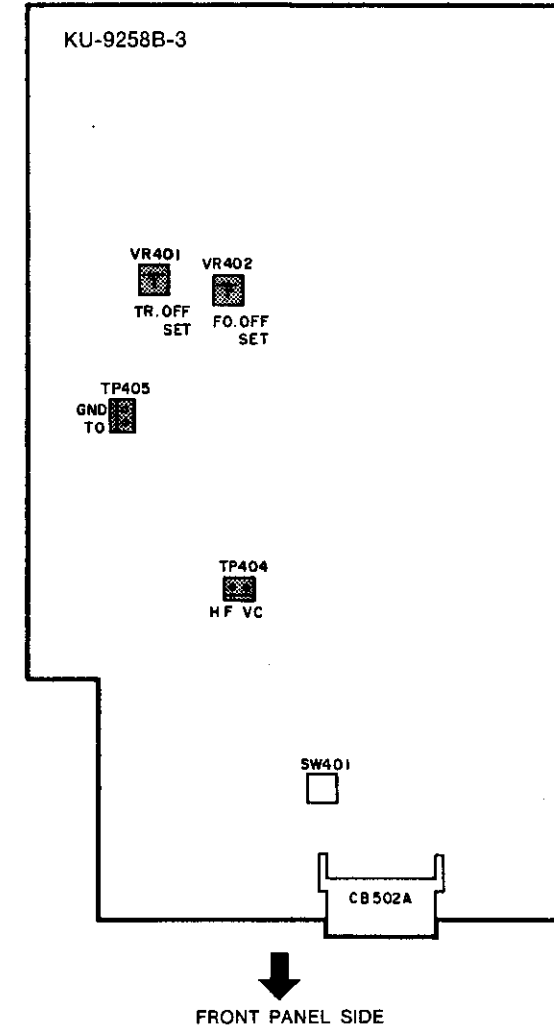

(2) Adjustment preparation

1.	Start the service program	
2.	Set the adjustment control (VR401, 402) to the position illustrated.	<p>VR401 (T-OFFSET)</p> <p>VR402 (F-OFFSET)</p> <p>90°</p>
3.	Adjustment step	<p>1. Tracking offset</p> <p>2. Focus offset</p>

(3) Tracking offset adjustment

Wiring Diagram

Oscilloscope (DC range)		Adjustment location	Check items	Adjustment procedure
V	H	(Control)	DC Voltmeter	
0.2V/div	1~2ms/div	VR401	<p>A=B</p>	<ol style="list-style-type: none"> ▶ OPEN/CLOSE Press the OPEN/CLOSE button and place an adjustment disc in the disc holder. ▶ OPEN/CLOSE Press the OPEN/CLOSE button again and close the disc holder. ▶ PLAY Press the PLAY button and check that the display indicates "02". Adjust the VR401 "T-OFFSET" control and set the upper and lower amplitude of the waveform to be equal.

(4) Focus offset Adjustment

Wiring diagram

Oscilloscope		Adjustment location	Check items
V	H	Control	Oscilloscope
50mV/div or 20mV/div	0.2 μ/div or 0.5 μ/div	VR402	<p>EFM waveform</p> <p>Adjust for the minimum pitch.</p> <p>EFM waveform</p>

Adjustment Procedure

- Press the **|| PAUSE** button.
- Check that the display of the track number indicates "03".
- Adjust VR402 ("F-OFFSET") so that the eye pattern jitter is minimum.

CD SECTION

SEMICONDUCTORS

● IC's
HA12158NT (IC401)

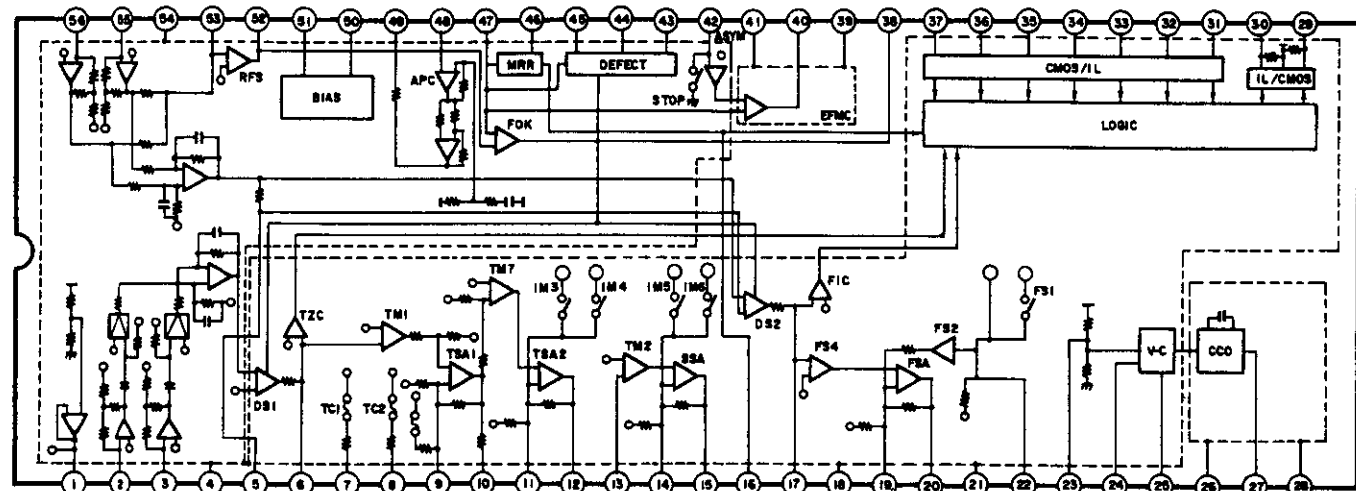
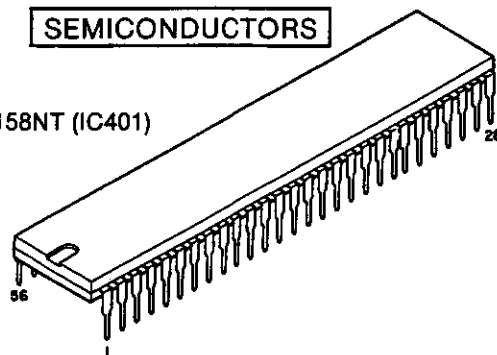

● Pin function table

Pin No.	Symbol	I/O	Function	Pin No.	Symbol	I/O	Function
1	VREF	O	Reference voltage output	29	COUT	O	Track count signal output
2	TR1	I	TR1 (I/V conversion amplifier) input	30	SENS	O	FZC and TZC signal output
3	TR2	I	TR2 (I/V conversion amplifier) input	31	XRST	I	Reset signal output
4	PG	GND	Preamplifier block ground	32	DIRC	I	Direct control signal output
5	FH	O	Focus error hold signal output	33	XLT	I	Data transfer signal input
6	TE	I/O	Track error signal output, TMI input	34	DATA	I	Data signal input
7	TG1	I	TG1 switch	35	CLK	I	Data sync clock input
8	TG2	I	TG2 switch	36	LMSW	I	Limit switch input
9	TS1	I	TSA1 ⊖ input	37	LDSW	I	Laser switch input
10	TS10	O	TSA1 output	38	FOK	O	FOK comparator output
11	TS2	I	TSA2 ⊖ input	39	GEFM	GND	EFM comparator ground
12	TS20	O	TSA2 output	40	EFMC	O	EFM comparator output
13	TM2	I	TM2 input	41	VEFM	Vcc	EFM comparator Vcc
14	SS	I	SSA ⊖ input	42	DSLCL	I	Data slice level control input
15	SSO	O	SSA output	43	DFIN	I	Defect comparator input
16	MIRR	O	Mirror comparator output	44	DFO	O	Defect signal output
17	FE	I/O	Focus error signal output, FSA input	45	DFH	O	Defect hold signal output
18	SG	GND	Servo block ground	46	MIRH	O	Error hold signal output
19	FS	I	SSA ⊖ input	47	EFMI	I	EFM signal output
20	FSA	O	FSA input	48	MD	I	APC amplifier input
21	SVCC	Vcc	Servo block Vcc	49	LD	O	APC amplifier output
22	FUD	O	Focus up/down voltage output	50	BYPS	O	Capacitor connection pin for ripple filter
23	VCR	I/O	VCO reference voltage	51	ISET	O	Reference current setting
24	PDIN	I	VCO control voltage input	52	RFO	O	RFS output
25	FRA	O	VCO free-run frequency setting	53	RF	I	RFS ⊖ input
26	VVcc	Vcc	VCO Vcc	54	PVcc	Vcc	Pre-block Vcc
27	VCO	O	VCO output	55	RF1	I	RF1 (I/V conversion block) input
28	VGND	GND	VCO ground	56	RF2	I	RF2 (I/V conversion block) input

SM5840CS (IC301)

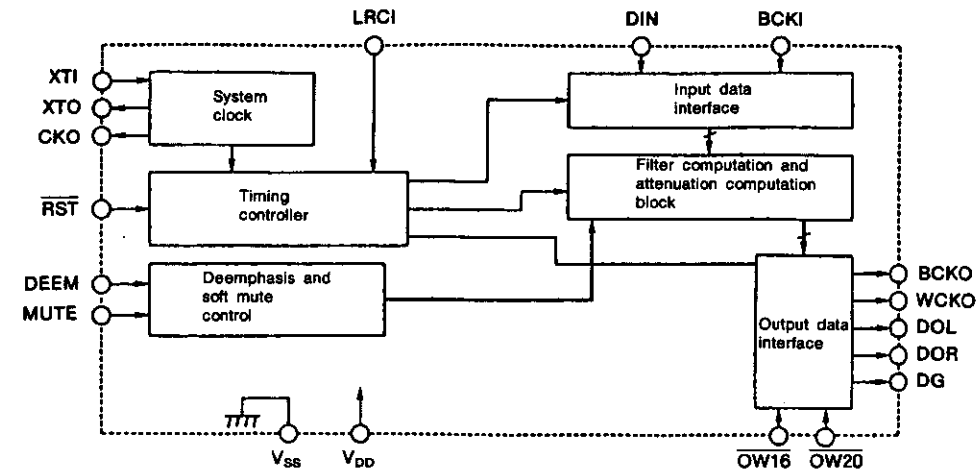
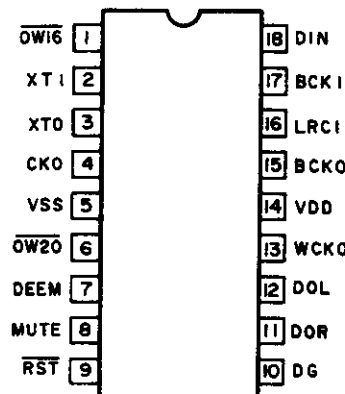
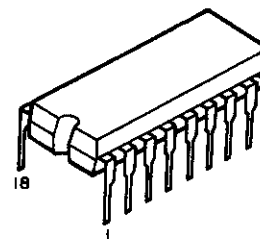

● SM5840CS Pin Description

Pin number DIP	Pin name	i/o	Function
1	OW16	ip	Selection pin 1 for number of output bits (NOTE) NS-ON : Noise shaper on NS-OFF : Noise shaper off Setting OW16 H 18bit output (NS-ON) 20bit output (NS-ON) L 16bit output (NS-ON) 18bit output (NS-ON)
2	XTI	i	Oscillator input pin
3	XTO	o	Oscillator output pin
4	CKO	o	Oscillator output clock (Frequency is the same as XTI)
5	Vss	-	Ground pin
	(N.C.)		
6	OW20	ip	Selection pin 2 for number of output bits (NOTE) See the column of OW16. (When OW20 is low level : 18 bits or 20 bits) (When OW20 is high level : 18 bits or 16 bits)
7	DEEM	ip	Deemphasis signal input (When DEM is low level : Deemphasis is off) (When DEM is high level : Deemphasis is on)
8	MUTE	ip	Mute signal input (When MUTE is low level : Soft mute is off) (When MUTE is high level : Soft mute is on)
9	RST	ip	System reset (Initialization)
10	DG	o	Degitch output
11	DOR	o	Right channel data output
12	DOL	o	Left channel data output
13	WCKO	o	Output word clock
14	VDD	-	Supply pin (5 V : Standard)
	(N.C.)		
	(N.C.)		
15	BCKO	o	Output bit clock
16	LRCI	ip	Clock of the input data sample rate (fs)
17	BCKI	ip	Input bit clock
18	DIN	ip	Input data

i : Input pin ip : Input pin with pull-up resistor o : Output pin

LC78820M (IC302)

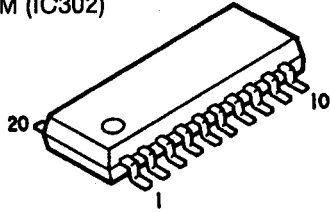

BA15218F (IC303, 404)

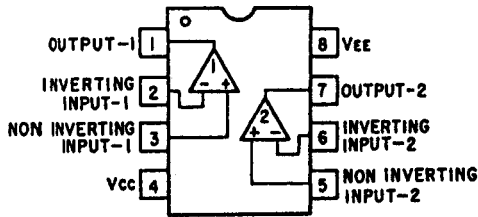
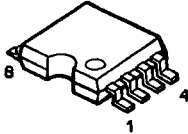

NJM78M05FA (IC306)

(Three-terminal positive constant voltage power supply)

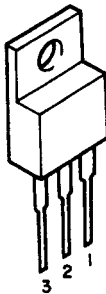

1: Output
2: GND
3: Input

MN1280S (IC502)

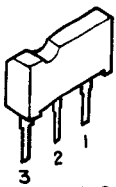

1: Output
2: VDD
3: GND

BA6290A (IC402, 403)

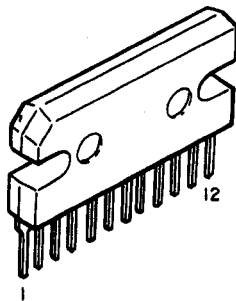

● LC78820M Pin Description

Pin No.	Name	Description of Function/Operation
1	CH1OUT	Channel 1 output pin. (Left channel)
2	VrefH1	High-level reference voltage input pin 1.
3	VrefH2	High-level reference voltage input pin 2. See (3) for example of applicable circuit.
4	VDD	+5 V supply pin.
5	WCLK	Word clock input pin. Produces the internal signal which latches the digital audio data, (DATAL and DATAR).
6	DATAL	Digital audio data input pin (left channel). Input as bit serial from the MSB side. Data is in the form of 2s complement.
7	DATAR	Digital audio data input pin (right channel). Input as bit serial from the MSB side. Data is in the form of 2s complement.
8	BCLK	Bit clock input pin. This clock is used for reading the digital audio data into the LSI in bit serial.
9	SYSCLK	System clock input pin. This is the main clock used for operating the LSI. This pin becomes the interface switching pin depending on the mode, (either mode 1 or 2). (See the timing chart.)
10	VDD	+5 V supply pin.
11	TSTOUT	Test output pin. It should normally be left open.
12	TST1	Test input pin. It should normally be connected to GND.
13	MODE1	Interface switching pins. See the timing chart.
14	MODE2	
15	GND	Ground pin.
16	VrefL1	Low-level reference voltage input pin 1.
17	GND	Ground pin.
18	VrefL2	Low-level reference voltage input pin 2. See (3) for example of applicable circuit.
19	NC	No connection.
20	CH2OUT	Channel 2 output pin. (Right channel)

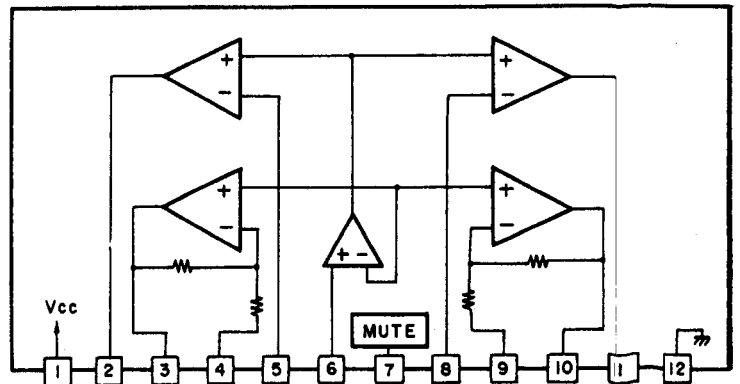

ICP-N15 (IC304, 305) IC Protector



CD SECTION

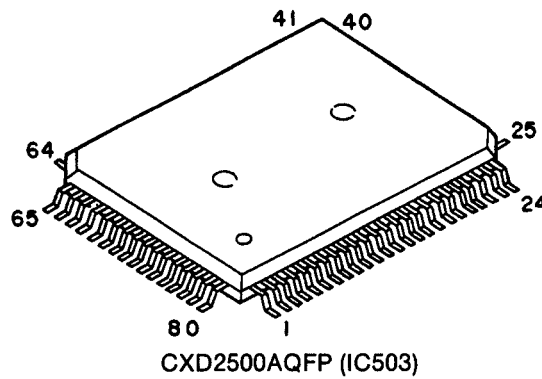

● CXD2500AQFP Pin Function Table

Pin no.	Pin symbol	I/O		Pin description
		I	O	
1	FOK	I		Focus OK input pin. Used in SENS output and the servo auto sequencer.
2	FSW	O	Z,0	Output filter switching output of the spindle motor.
3	MON	O	1,0	On-off control output of the spindle motor.
4	MDP	O	1,Z,0	Servo control of the spindle motor.
5	MDS	O	1,Z,0	Servo control of the spindle motor.
6	LOCK	O	1,0	Samples GFS at 460 Hz. When GFS is "H", H is output. L is output when there is "L", 8 times in succession.
7	NC		—	
8	VCOO	O	1,0	Oscillation circuit output for analog EFM PLL.
9	VCOI	I		Oscillation circuit output for analog EFM PLL. $f_{LOCK} = 8.6436$ MHz.
10	TEST	I		Test pin, always grounded.
11	PDO	O	1,Z,0	For charge pump used with analog EFM PLL.
12	V _{SS}			Ground
13	NC		—	
14	NC		—	
15	NC		—	
16	VPCO	O	1,Z,0	PLL charge pump output used for vari-pitch.
17	VCKI	O		Clock input f_{CENTER} from the external VCO for varipitch equals 16.9344 MHz.
18	FILO	O	Analog	Filter output (slave = digital PLL) for master PLL.
19	FILI	I		Filter input for master PLL.
20	PCO	O	1,Z,0	Charge pump output for master PLL.
21	A _{VSS}			Analog ground.
22	CLTV	I		VCO control voltage input for master.
23	A _{VDD}			Analog supply (+5 V)
24	RF	I		EFM signal input
25	TEST2	I		Grounded
26	TEST3	I		Grounded
27	ASYO	O	1,0	EFM full-swing output. (L = V _{SS} , H = V _{DD})
28	TEST4	I		Grounded
29	NC		—	
30	PSSL	I		Switching input for the audio data output mode. Serial output with "L" and parallel output with "H".
31	WDCK	O	1,0	D/A interface for 48-bit slot. Word clock $f = 2F_s$.
32	LRCK	O	1,0	D/A interface for 48-bit slot. LR clock $f = F_s$.
33	V _{DD}			Supply (+5 V)

Pin no.	Pin symbol	I/O		Pin description
34	DA16	O	1,0	DA16 (MSB) output when PSSL = 1. Serial data of the 48-bit slot when PSSL = 0. (2s' COMP, MSB first.)
35	DA15	O	1,0	DA15 output when PSSL = 1. Bit clock of the 48-bit slot when PSSL = 0.
36	DA14	O	1,0	DA14 output when PSSL = 1. Serial data of the 64-bit slot when PSSL = 0. (2s' COMP, LSB first.)
37	DA13	O	1,0	DA13 output when PSSL = 1. Bit clock of the 64-bit slot when PSSL = 0.
38	DA12	O	1,0	DA12 output when PSSL = 1. LR clock of the 64-bit slot when PSSL = 0.
39	DA11	O	1,0	DA11 output when PSSL = 1. GTOP output when PSSL = 0.
40	DA10	O	1,0	DA10 output when PSSL = 1. XUGF output when PSSL = 0.
41	DA09	O	1,0	DA09 output when PSSL = 1. XPLCK output when PSSL = 0.
42	DA08	O	1,0	DA08 output when PSSL = 1. GFS output when PSSL = 0.
43	DA07	O	1,0	DA07 output when PSSL = 1. RFCK output when PSSL = 0.
44	DA06	O	1,0	DA06 output when PSSL = 1. C2P0 output when PSSL = 0.
45	DA05	O	1,0	DA05 output when PSSL = 1. XRAOF output when PSSL = 0.
46	DA04	O	1,0	DA04 output when PSSL = 1. MNT3 output when PSSL = 0.
47	DA03	O	1,0	DA03 output when PSSL = 1. MNT2 output when PSSL = 0.
48	DA02	O	1,0	DA02 output when PSSL = 1. MNT1 output when PSSL = 0.
49	DA01	O	1,0	DA01 output when PSSL = 1. MNT0 output when PSSL = 0.
50	APTR	O	1,0	Control output for aperture correction. "H" with Rch.
51	APTL	O	1,0	Control output for aperture correction. "H" with Lch.
52	Vss			Ground
53	XTAI	I		16.9344 MHz x'tal oscillator circuit input. Or 33.8688 MHz input.
54	XTAO	O	1,0	16.9344 MHz x'tal oscillator circuit input.
55	XTSL	I		X'tal selection input pin. "L" when the x'tal is 16.9344 MHz and "H" when the x'tal is 33.8688 MHz.
56	FSTT	O	1,0	2/3 frequency division output of pins 53 and 54. Does not change with vary-pitch.
57	C4M	O	1,0	4.2336 MHz output. Changes simultaneously when varypitch is applied.
58	C16M	O	1,0	16.9344 MHz output. Changes simultaneously when varypitch is applied.
59	MD2	I		Digital-Out on/off control. H when on and L when off.
60	DOUT	O	1,0	Digital-out output pin.
61	EMPH	O	1,0	When the playback disc has emphasis, "H" is output. "L" is output when there is no emphasis.
62	WFCK	O	1,0	WFCK (Write Frame Clock) output.
63	SCOR	O	1,0	"H" output when either sub code sync S0 or S1 is detected.
64	SBSO	O	1,0	Sub P through W serial output.
65	EXCK	I		Clock input for SBSO read-out use.
66	SQSO	O	1,0	SubQ 80 bit and PCM peak level data 16-bit output.
67	SQCK	I		Clock input for SQSO read-out use.
68	MUTE	I		Mute L is cancelled with H.
69	SENS	-	1,Z,0	SENS output. Output to CPU.
70	XRST	I		System set. Reset with "L".
71	DATA	I		Serial data input from CPU.
72	XLAT	I		Latch input from CPU. Latches serial data on the fall.
73	VDD			Supply (+5 V)
74	CLOK	I		Serial data transfer clock input from CPU.
75	SEIN	I		Sense input from SSP.
76	CNIN	O		Count signal input of number of track jumps.
77	DATO	O	1,0	Serial data output to SSP.
78	XLTO	O	1,0	Serial data latch output to SSP. Latches on the fall.
79	CLKO	O	1,0	Serial data transfer clock output to SSP.
80	MIRR	I		Mirror signal input. Used in jumps of 128 tracks or more with an auto sequencer.

CD SECTION

μ PD75116GF-F70-3BE (IC501)

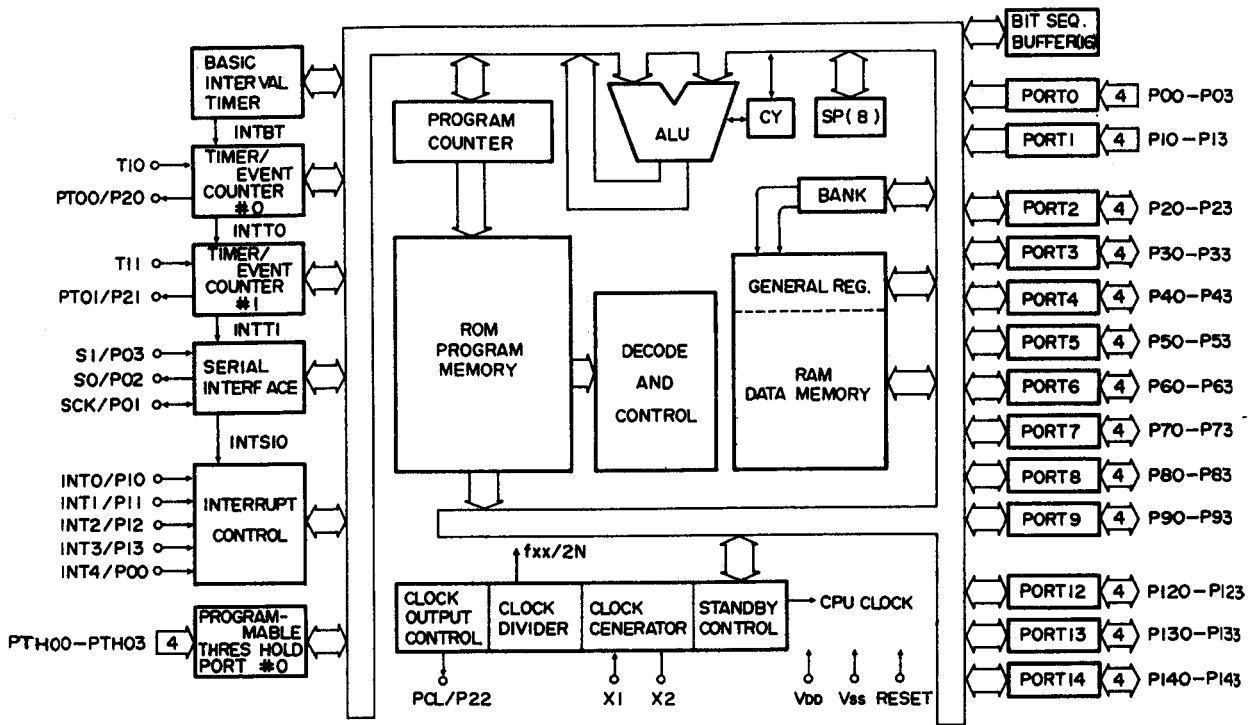
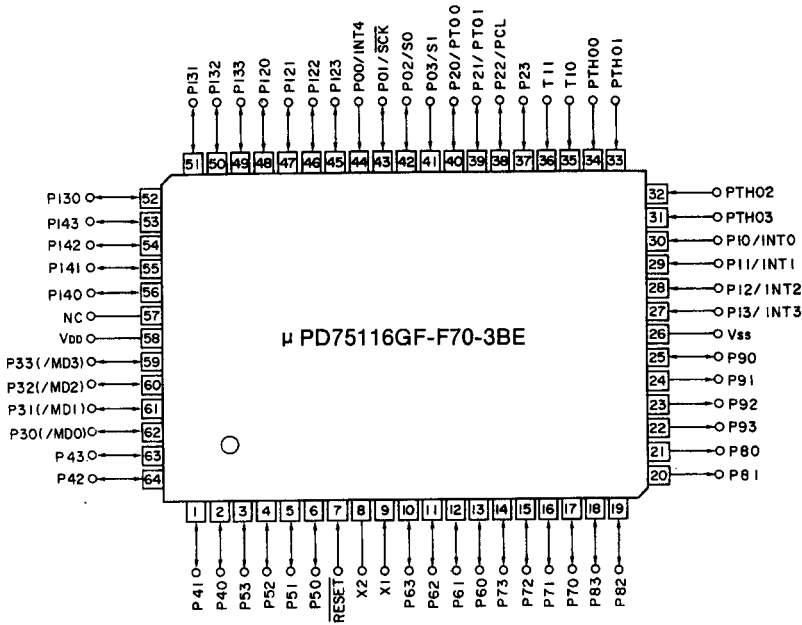
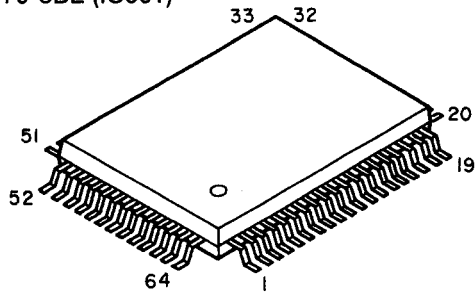

● IC Pin Description

No.	Part name	Function name	Function	I/O	I	A
1	P41	POWER ON/OFF OUT	Output that controls power on/off switching.	O	H	L
2	P40	DSP RESET	Reset signal output for DSP.	O	L	H
3	P53	DIGITAL OFF OUT	Output that controls digital on/off switching.	O	L	H
4	P52	STANDBY OUT	Output that controls power on/off switching.	O	L	H
5	P51	KS9	Key scan.	O	L	H
6	P50	KS8	Key scan.	O	L	H
7	RESET			I		
8	X2			O		
9	X1			I		
10	P63	KS7	Key scan.	O	L	H
11	P62	KS6	Key scan.	O	L	H
12	P61	KS5	Key scan.	O	L	H
13	P60	KS4	Key scan.	O	L	H
14	P73	KS3	Key scan.	O	L	H
15	P72	KS2	Key scan.	O	L	H
16	P71	KS1	Key scan.	O	L	H
17	P70	KS0	Key scan.	O	L	H
18	P83	NC		O		
19	P82	NC		O		
20	P81	NC		O		
21	P80	PLAY	Outputs a high-level signal during play mode.	O	L	H
22	P93	INITIAL	Test pin.	O	-	
23	P92	EDIT	Test pin.	O	-	
24	P91	SEARCH	Test pin.	O	-	
25	P90	PDOUT	Digital output control pin.	O	-	
26	VSS			-		
27	P13/INT3	50/60 IN	Commercial power supply pulse input pin.	I	H	-
28	P12/INT2	PGFS	Revolution synchronous signal input from DSP.	I	L	H
29	P11/INT1	PSCOR	Sub-code synchronous signal input.	I	L	-
30	P10/INT0	SERIAL SIG IN	Auto function input.	I	H	-
31	PTH03	KR1	Key return.	I	L	H
32	PTH02	KR2	Key return.	I	L	H
33	PTH01	KR3	Key return.	I	L	H
34	PTH00	KR4	Key return.	I	L	H
35	T10	PSENSE	Servo condition detection signal input.	I	H	-
36	T11	RESET IN	Pin for reset detection.	I	H	-
37	P23	DATA	Servo control signal and data output for D and F.	O	H	-
38	P22/PCL	XLT	Servo control signal latch output.	O	H	LP
39	P21/PT01	CLK	Servo control signal and clock output for D and F.	O	H	-
40	P20/PT00	PLASER	Laser on/off control output.	O	H	L
41	P03/SI	PSUBQ	Sub-code data input.	I	H	-
42	P02/SO	NC		O		
43	P01/SCK	PSQCK	Clock output for sub-code reading.	O	H	-
44	P00/INT4	SCI ENABLE	Enable pin for display data reception.	I	H	-
45	P123	LATCH	Latch output for D and F.	O	H	LP
46	P122	A.MUTE	Audio mute output.	O	H	H
47	P121	EMPHA	Signal output with emphasis control.	O	H	L
48	P120	PDIRC	Servo control signal output.	O	H	LP
49	P133	PMVCL	Loader drive signal.	O	H	L
50	P132	PMVOP	Loader drive signal.	O	H	L
51	P131	PDMUT	Mute output for the LSI.	O	H	H
52	P130	SERIAL SIG OUT	Auto function output.	O	H	-
53	P143	PFOK	Focus OK signal output.	I	L	H
54	P142	PSWOPN	Loader open position detection.	I	H	L
55	P141	PSWCLS	Loader open position detection.	I	L	L
56	P140	PSWPMD	Pickup inner track position detection.	I	-	L
57	NC		No connection.			
58	VDD	VDD	Connect to 5V.	-		
59	P33/MD3	SI	Data input pin for display data reception.	I	H	-
60	P32/MD2	A.P.SEL IN	Selects the auto power on/off function.	I	-	-
61	P31/MD1	SCK	Clock output pin for display data transmission.	I	H	-
62	P30/MD0	CD ON/OFF	Digital on/off control input.	I	L	H
63	P43	NC		O		
64	P42	SO	Data output pin for display data transmission.	O	H	-

I = Initial, A = Active

● Transistors

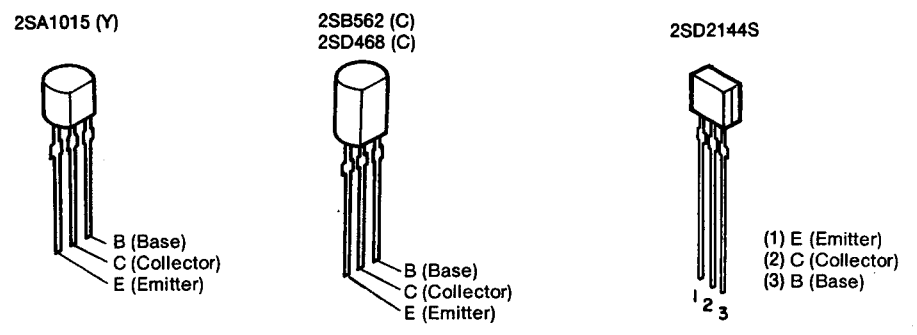

Digital Transistor (Built in Resistors)

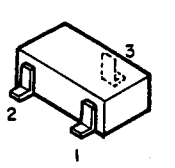

1: GND / Emitter
2: Out / Collector
3: In / Base

DTA114EK ... PNP Type
DTC114EK } NPN Type
DTC144EK (Chip)

DTAEK Series

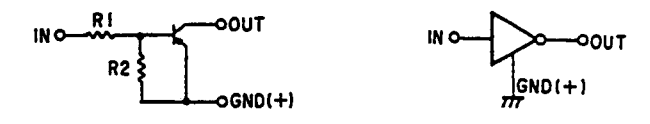

	R1	R2
DTA114EK	10k ohm	10k ohm

DTCEK Series

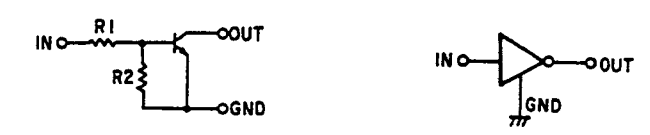

	R1	R2
DTC114EK	10k ohm	10k ohm
DTC144EK	47k ohm	47k ohm

● Diodes (included LED)

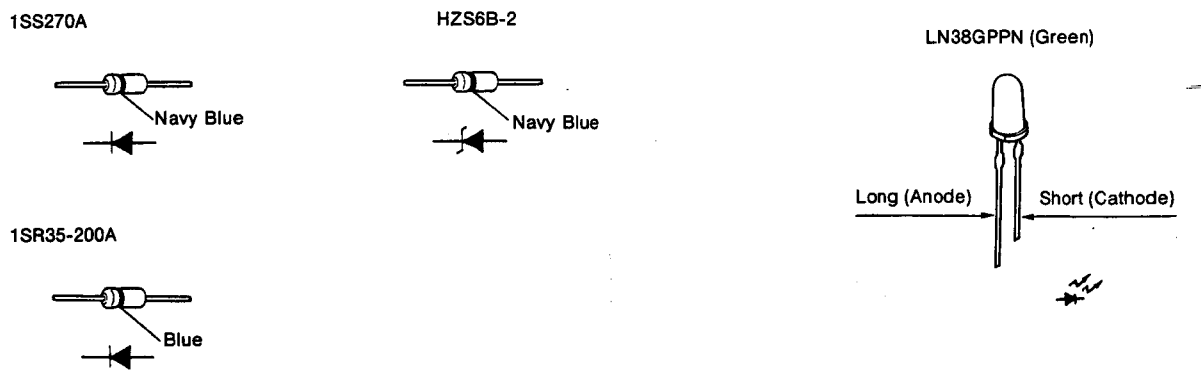

MICROPROCESSOR PERIPHERAL WIRING DIAGRAM

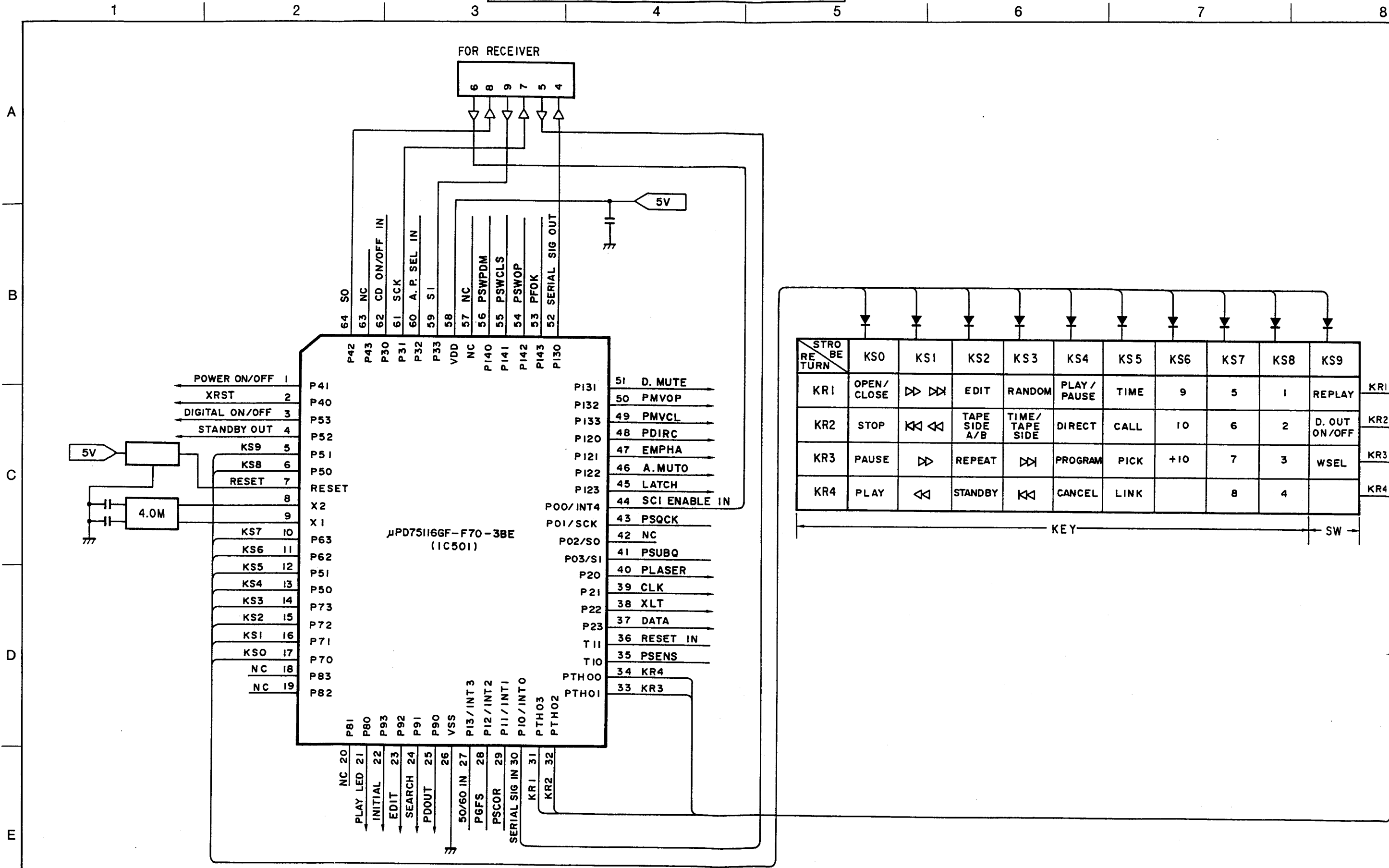

STRO RE TURN	KS0	KS1	KS2	KS3	KS4	KS5	KS6	KS7	KS8	KS9	
KR1	OPEN/ CLOSE	▷▷	EDIT	RANDOM	PLAY/ PAUSE	TIME	9	5	1	REPLAY	KR1
KR2	STOP	◁◁	TAPE SIDE A/B	TIME/ TAPE SIDE	DIRECT	CALL	10	6	2	D. OUT ON/OFF	KR2
KR3	PAUSE	▷	REPEAT	◁	PROGRAM	PICK	+10	7	3	WSEL	KR3
KR4	PLAY	◁	STANDBY	◁◁	CANCEL	LINK		8	4		KR4

KEY → SW

WIRING DIAGRAM

1 2 3 4 5 6 7 8

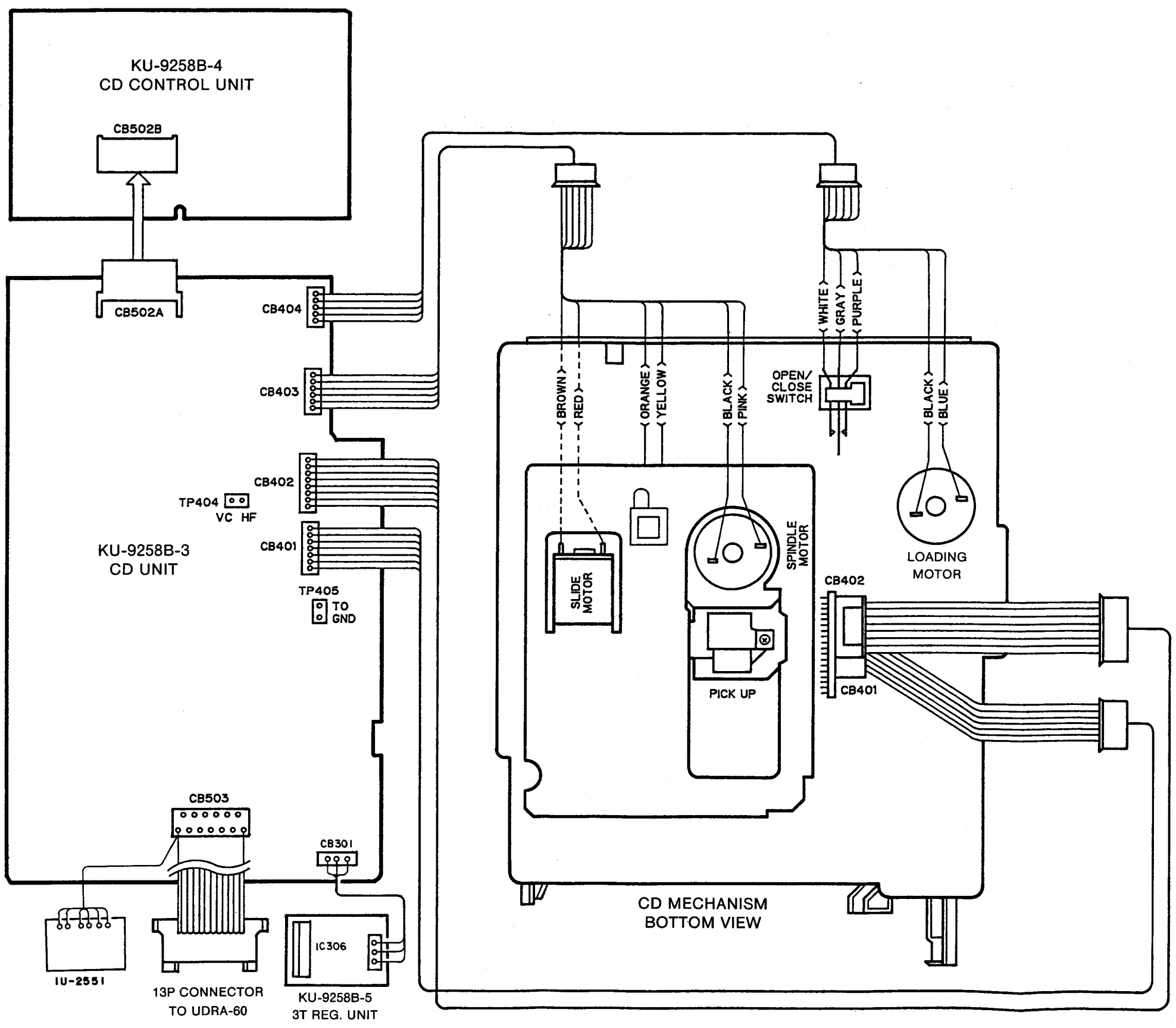

A
B
C
D
E

CD SECTION

DISASSEMBLY OF CD MECHANISM

Part No.: 337 0017 005

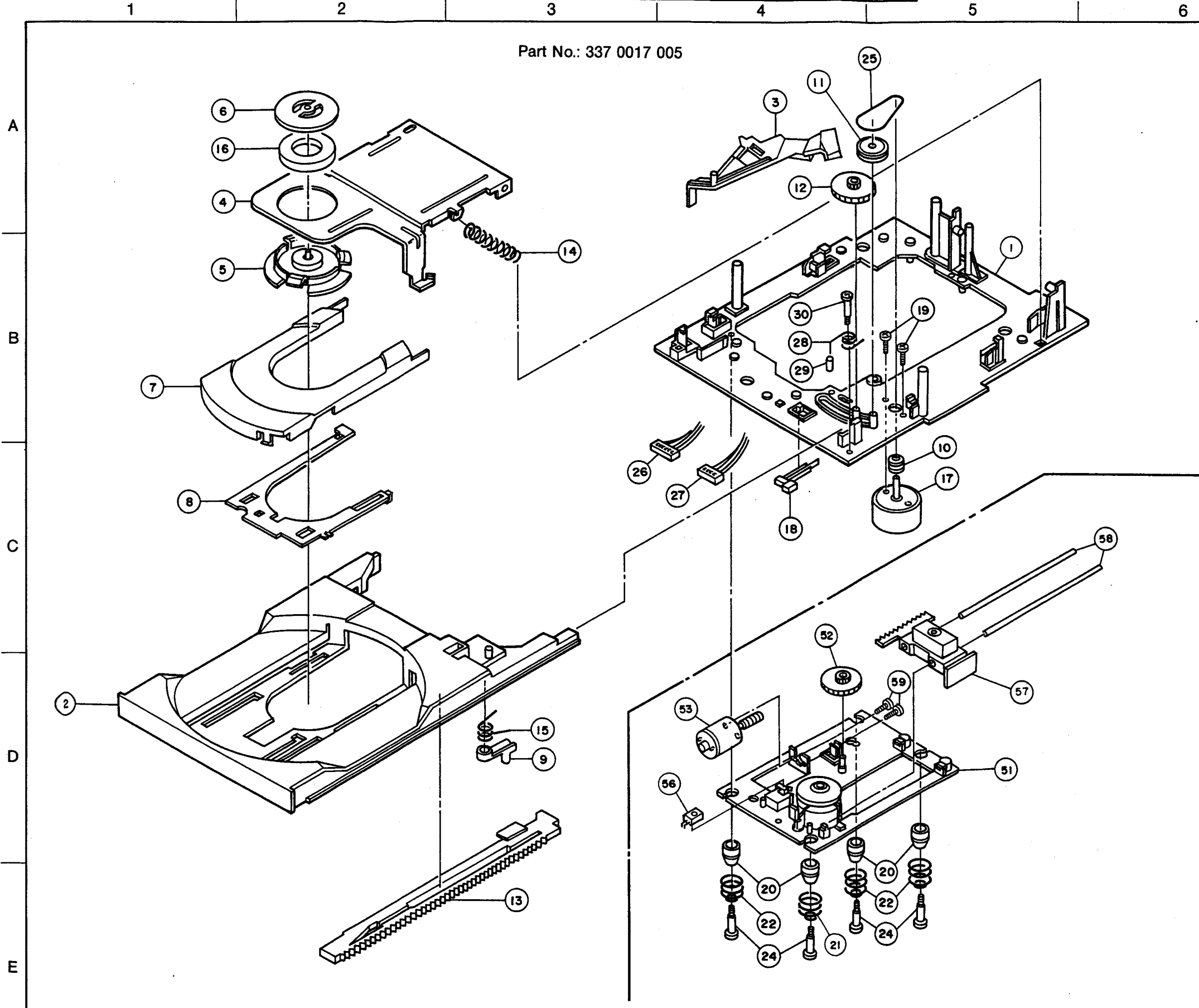

CD MECHANISM PARTS LIST

Ref. No.	Part No.	Part Name	Remarks	Q'ty
1	9KA 81A2 95	Loading Plate Ass'y OS		1
1-1	9KA —	Loading Plate		1
2	9KA 81G9 73	Tray 201		1
3	9KA 81G9 74	Switch Lever		1
4	9KA 81P4 62	Clamper Arm		1
5	9KA 81G9 75	Clamper		1
6	9KA 81P4 63	Clamper Plate		1
7	9KA 81G9 76	Disc Holder		1
8	9KA 81G9 77	Lifter Cam		1
9	9KA 81G9 78	Latch		1
10	9KA 81G2 35	Motor Pulley	Mold	1
11	9KA 81G1 22	Pulley Gear		1
12	9KA 81G1 23	Gear 3		1
13	9KA 81G5 81	Rack 11B		1
14	9KA 81S0 59	Clamp Spring		1
15	9KA 81S0 60	Latch Spring		1
16	9KA 82G0 57	Clamper Magnet		1
17	9KM 01T0 94	Motor	MDN-4RA3EZAS	1
18	9KS 01W0 51	Leaf Switch	LSC122338	1
19	9KM 20S0 04	Tams Screw	M2X4	2
20	9KA 82G0 56	Float Cushion M3		4
21	9KA 81S0 66	Float Spring M3A		1
22	9KA 81S0 67	Float Spring M3B		3
23	—	—		—
24	9KA 81H0 85	Fixing Screw C		4
25	9KA 82G1 80	Belt 1.4X18.1		1
26	9KA 82G1 23	Connector Cord	CNW6PM3	1
27	9KA 82G1 24	Connector Cord	CNW5PM3	1
28	9KA 81S0 71	Tray Spring 201		1
29	9KA 82G1 84	UL Tube 2X5.5		1
30	9KA 82H0 35	Floater Screw RM		1
31	—	—		—
32	—	—		—
51	9KA 81A3 33	Spindle Motor (T/T) Ass'y	Including Motor, T/T	1
51-1	—	Unit Plate M3G2		1
52	9KA 81G9 66	Slide Gear T		1
53	9KA 81A2 90	Feed Motor Ass'y		1
53-1	—	F. Motor	RD-050Y	1
53-2	—	Warm Gear T		1
54	9KA 81A2 93	Turn Table Ass'y		1
54-1	—	Turn Table Plate		1
55	9KM 01T0 94	Motor	MDN-4RA3EZAS	1
56	9KS 01W0 56	Switch	SW-SPPB-11	1
57	9KA 81G7 49	Pickup M3	HOPM3TR	1
58	9KA 81H1 07	Guide Bar		2
59	9KM 20N0 03	Pan Screw	M2X3	4
60	—	—		—
61	—	—		—
62	—	—		—

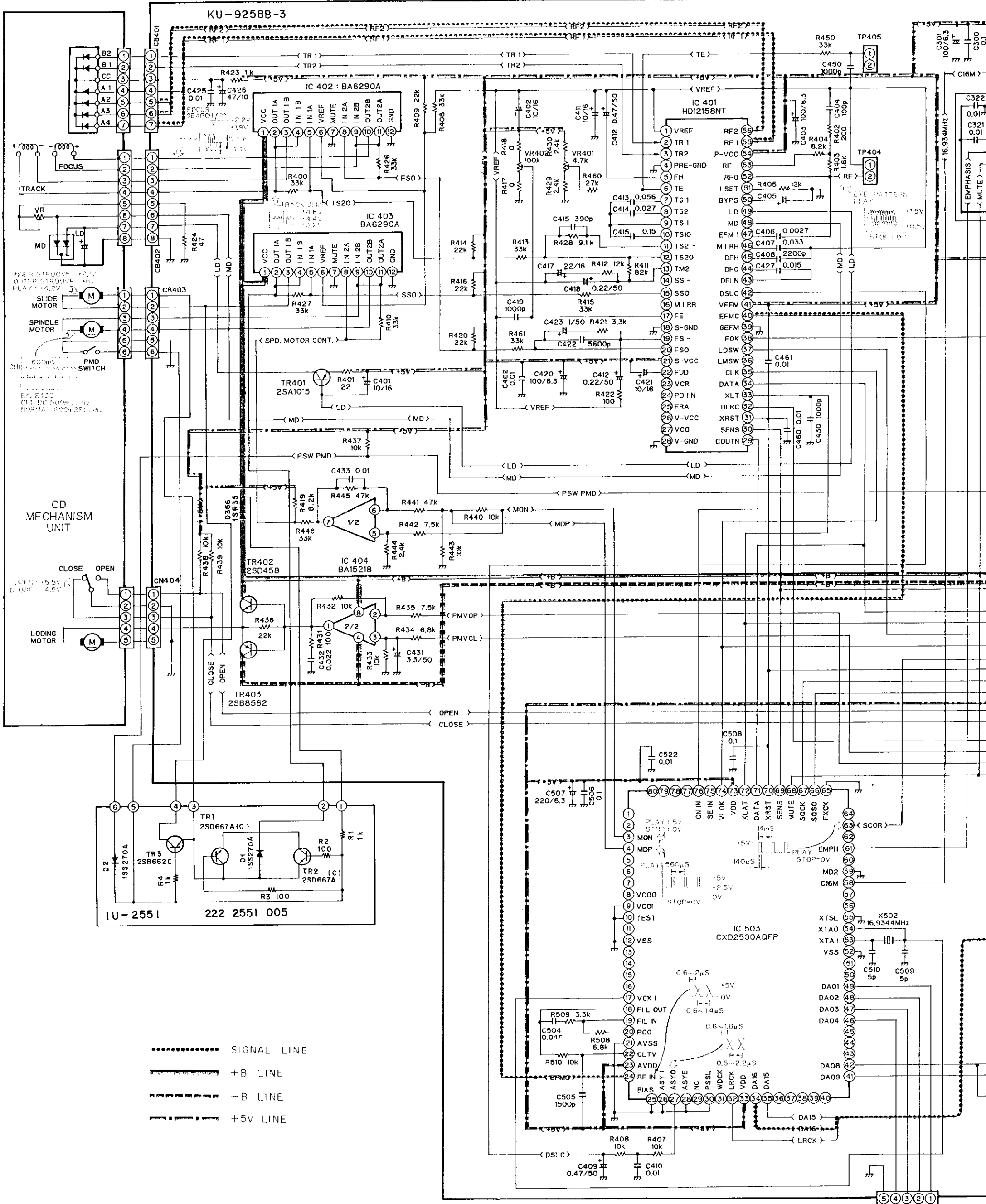

..... SIGNAL LINE
 --- +B LINE
 --- -B LINE
 --- +5V LINE

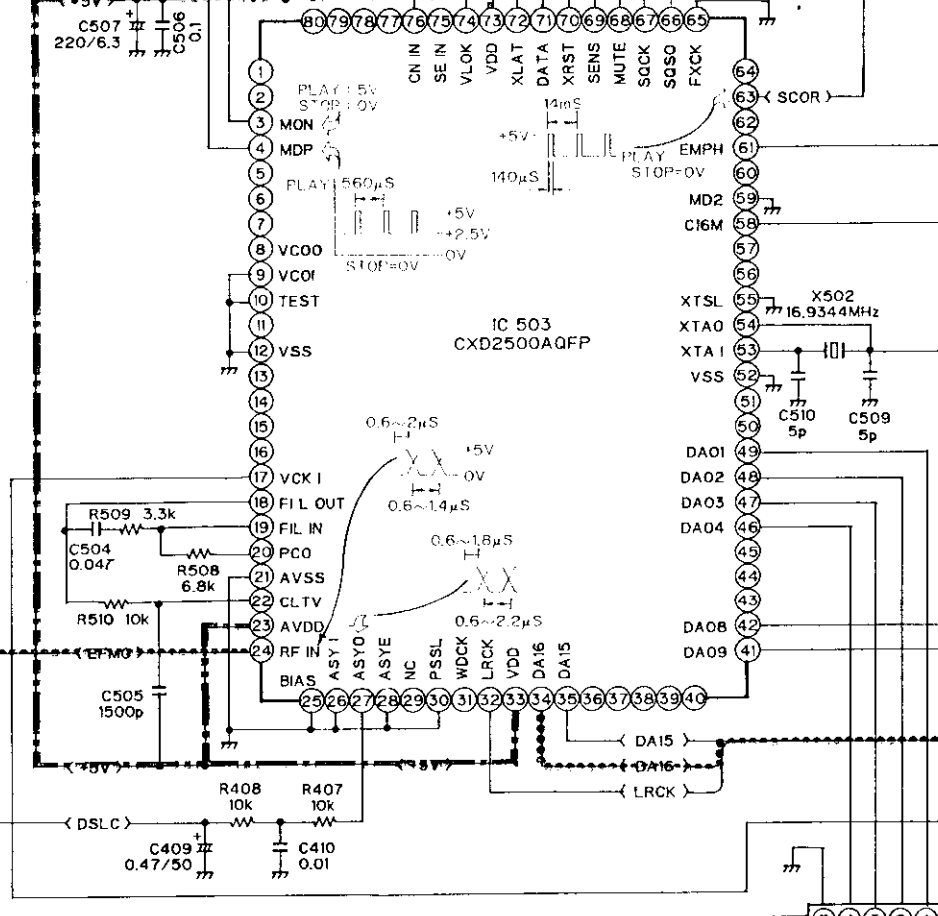
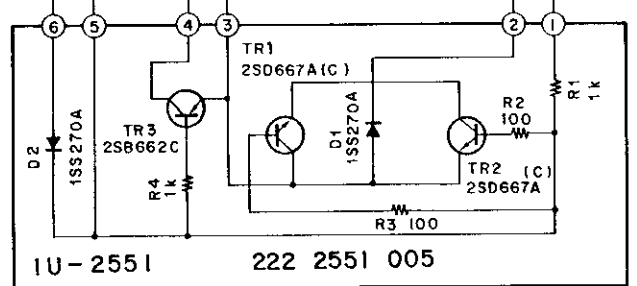

5 4 3 2 1

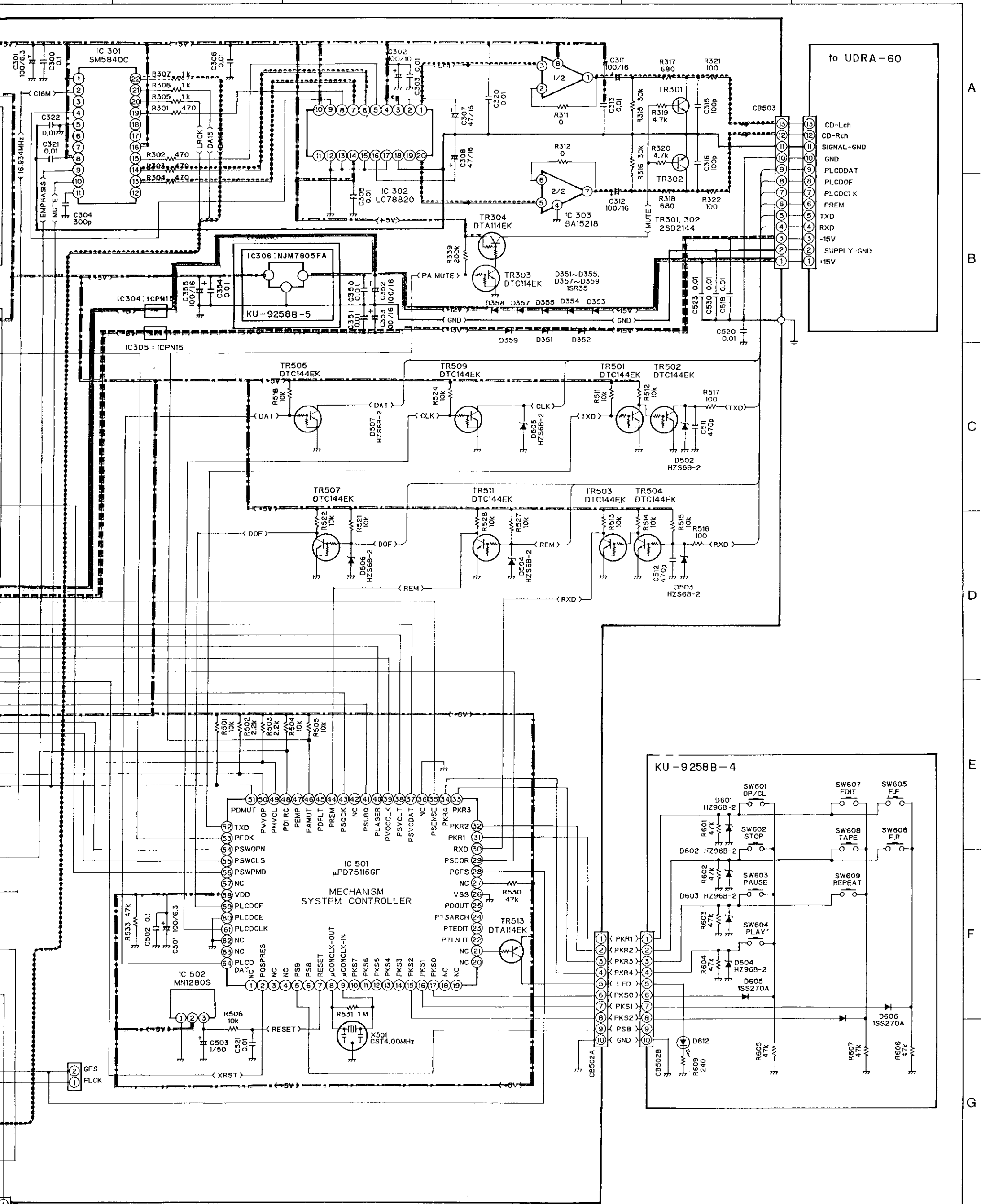

WARNING:
Parts marked with this symbol have critical characteristics.
Use ONLY replacement parts recommended by the manufacturer.

NOTES
ALL RESISTANCE VALUES IN OHM K=1,000 OHM M=1,000,000 OHM
ALL CAPACITANCE VALUES IN MICRO FARAD P=MICRO-MICRO FARAD
EACH VOLTAGE AND CURRENT ARE MEASURED AT NO SIGNAL INPUT CONDITION.
CIRCUIT AND PARTS ARE SUBJECT TO CHANGE WITHOUT PRIOR NOTICE.

A
B
C
D
E
F
G
H

CD SECTION

EXPLO

PARTS LIST OF UCD-60 EXPLODED

Ref. No.	Part No.	Part Name	Remarks	Q'ty
1	411 1158 203	Chassis		1
2	124 0079 007	Felt Sheet		1
3	105 1026 317	Rear Panel		1
4	103 1538 100	Mecha Holder (A)		1
5	103 1539 002	Mecha Holder (B)		1
6	337 0017 005	CD Mecha Unit		1
7	146 1348 106	Front Panel		1
8	143 0783 006	Lens		1
9	113 1507 002	Play Knob		1
10	104 0258 002	Foot Ass'y		2
11	GEN 1975	Loader Panel (C) Ass'y		1
12	102 0508 015	Top Cover		1
13	204 6333 030	13P System Conn. Cord		1
14	KU- 9258 B-3	CD Unit		1
15	KU- 9258 B-4	CD SW. Unit		1
16	461 0577 071	Rubber Sheet		1
17	393 9509 006	LED LN38GP PN	D612	1
18	204 2307 028	7P PH-PH Conn. Cord		1
19	204 2306 032	8P PH-PH Conn. Cord		1
20	KU- 9258 B-5	CD REG. Unit		1
21	1U- 2551	SLD Cont. Unit		1 ^S
SCREWS				
51	473 7002 021	Tapping Screw (S) 3x8		8
52	473 7500 044	Tapping Screw (P) 3x8	Black	8
53	473 7015 018	Tapping Screw (S) 3x8	Black	4
54				
PACKING & ACCESSORIES (Not included EXPLODED VIEW)				
71	505 0248 008	Cabinet Cover	600x600	1
72	513 1818 111	Unit Sheet		1
73	503 9236 002	Cushion		1
74	513 1581 008	Serial No. Sheet		1

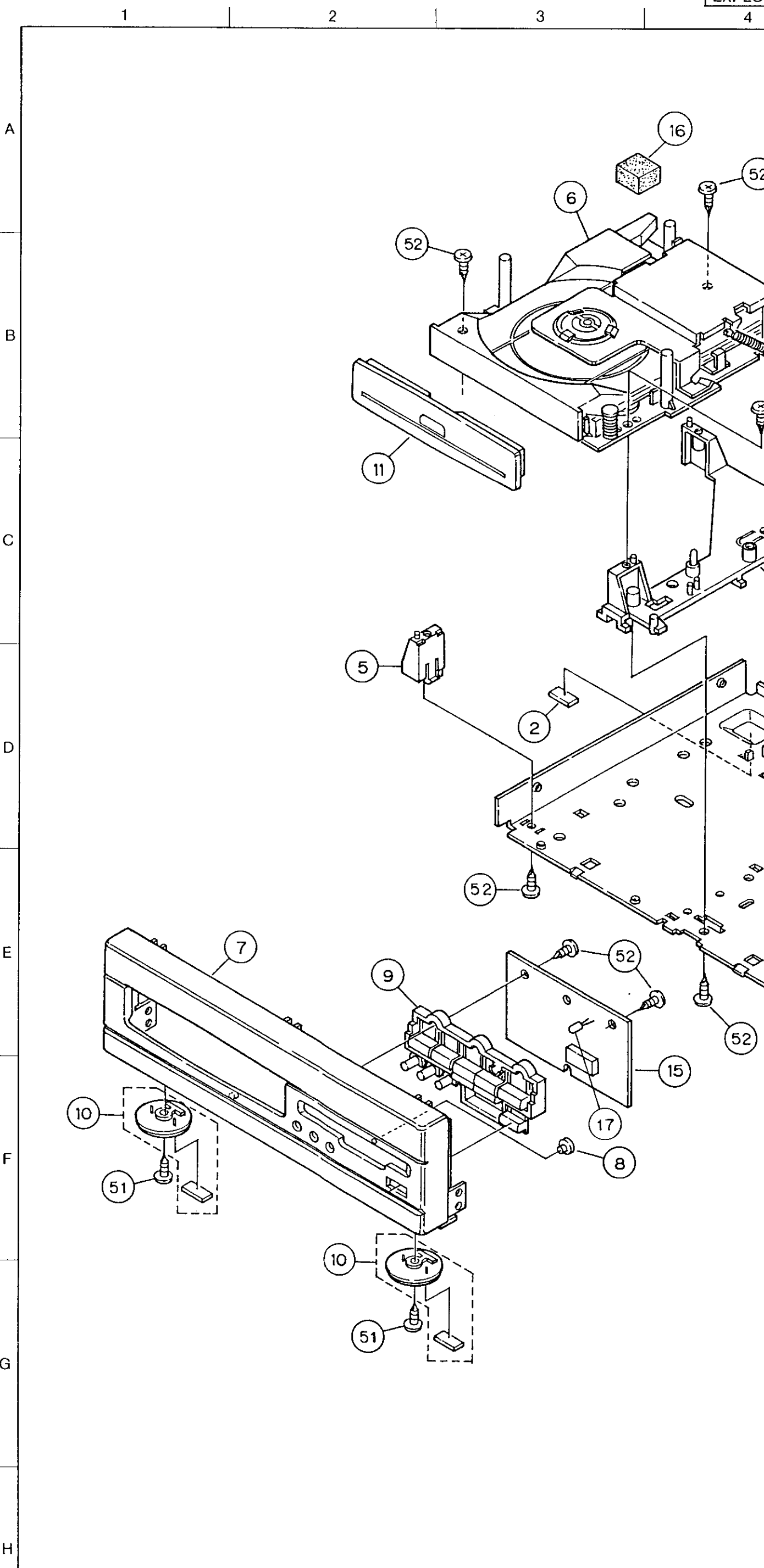

EXPLODED VIEW

4

5

6

7

8

9

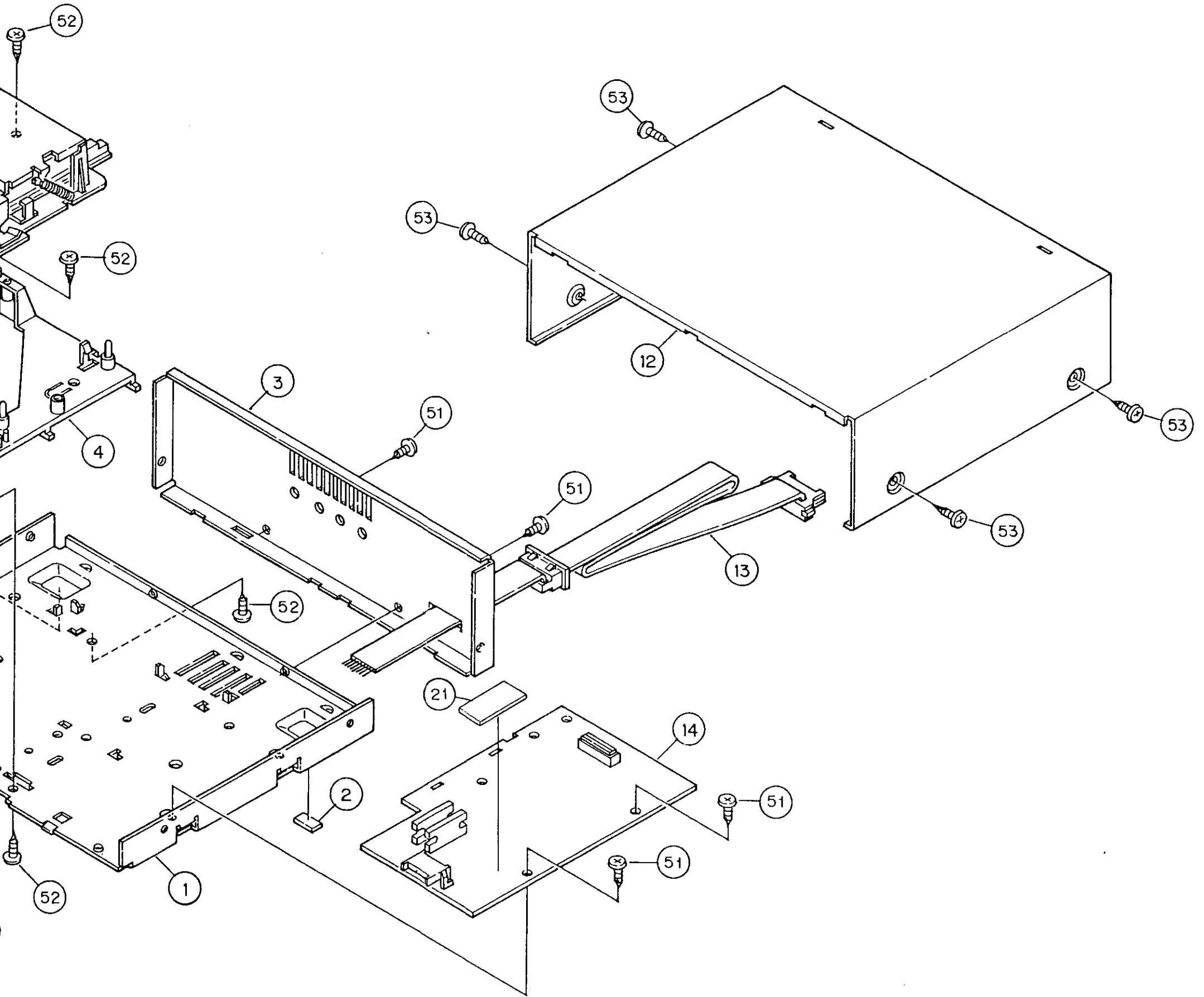

NOTE FOR PARTS LIST

- Part indicated with the mark "●" are not always in stock and possibly to take a long period of time for supplying, or in some case supplying of part may be refused.
- When ordering of part, clearly indicate "1" and "1" (i) to avoid mis-supplying.
- Ordering part without stating its part number can not be supplied.
- Part indicated with the mark "★" is not illustrated in the exploded view.

WARNING:

Parts marked with this symbol Δ  have critical characteristics. Use ONLY replacement parts recommended by the manufacturer.

GENERAL SECTION-2

PRINTED WIRING BOARD

1U-2410B P.W.B. UNIT (3) This unit is wholly used in the receiver section.

Component Side

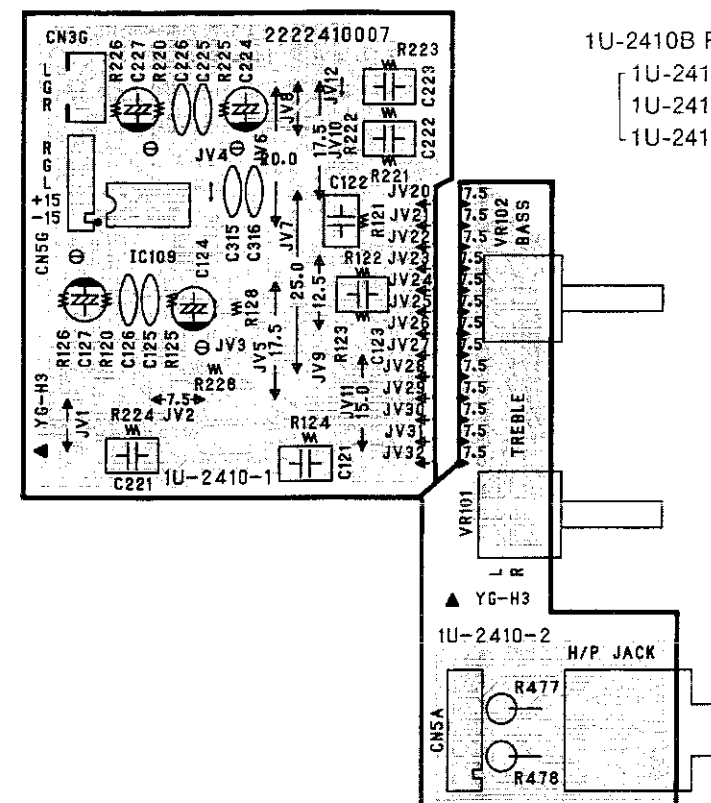

1U-2410B P.W.B. UNIT
 1U-2410-1 TONE Unit
 1U-2410-2 TONE VOL. Unit
 1U-2410-3 INPUT Unit

Pattern Side

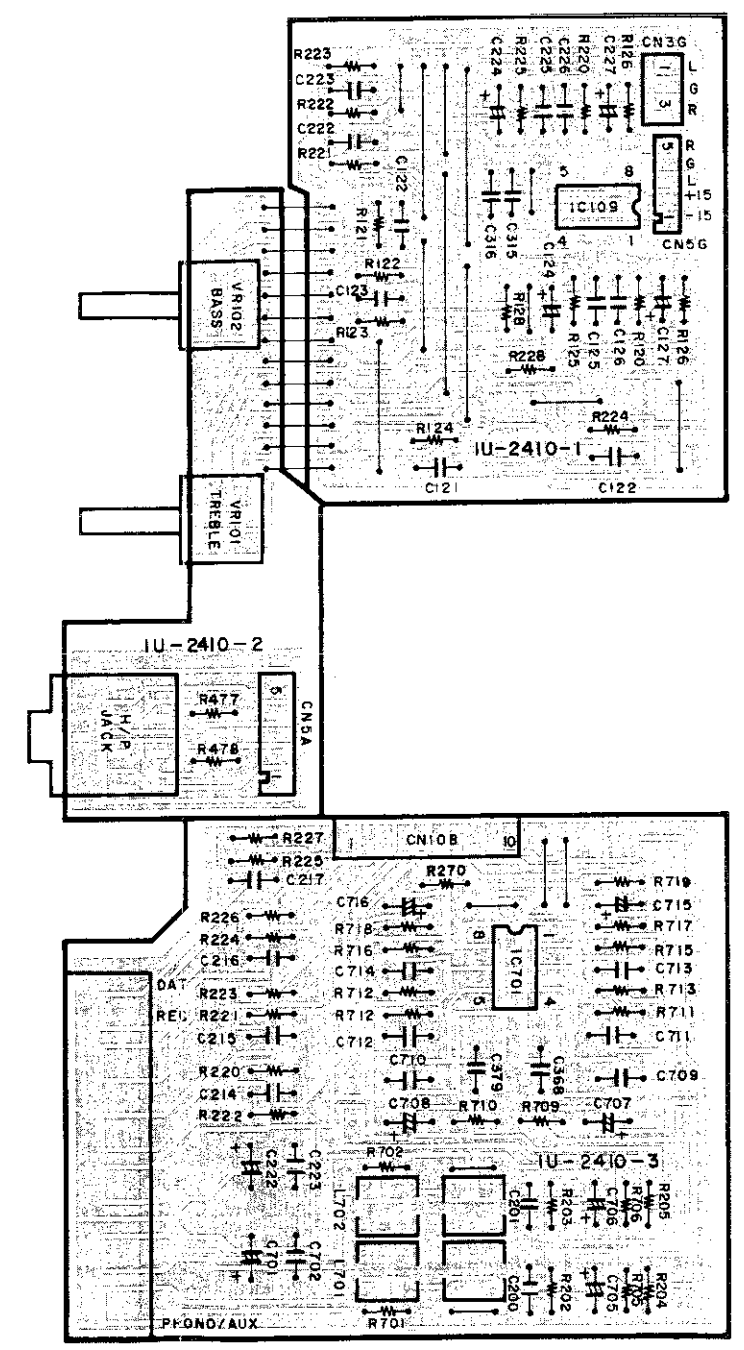

1U-2528 RESET UNIT This unit is wholly used in the cassette deck section.

Component Side

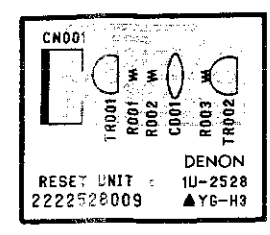

Pattern Side

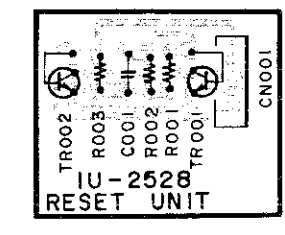

1U-2551 SLD CONT. UNIT This unit is wholly used in the CD player section.

Component Side

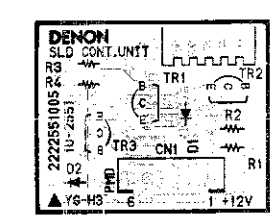

Pattern Side

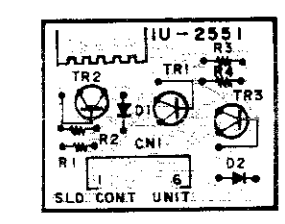

A
B
C
D
E

GENERAL SECTION-2

1 2 3 4 5 6 7 8

Component Side KU-9257B DECK UNIT ASS'Y

A

B

C

D

E

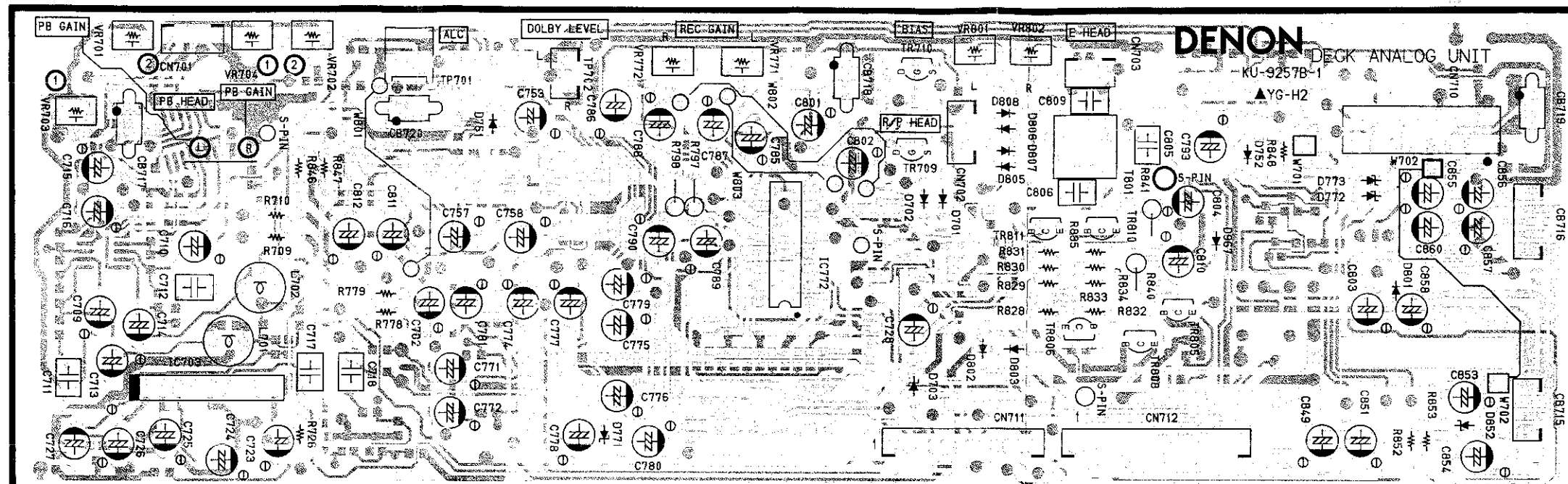

This unit is wholly used in the Cassette Deck Section.

- KU-9257B DECK UNIT ASS'Y
- KU-9257B DECK ANALOG Unit
- KU-9257B DECK DIGITAL Unit
- KU-9257B DECK DISPLAY Unit
- KU-9257B DECK REG. Unit

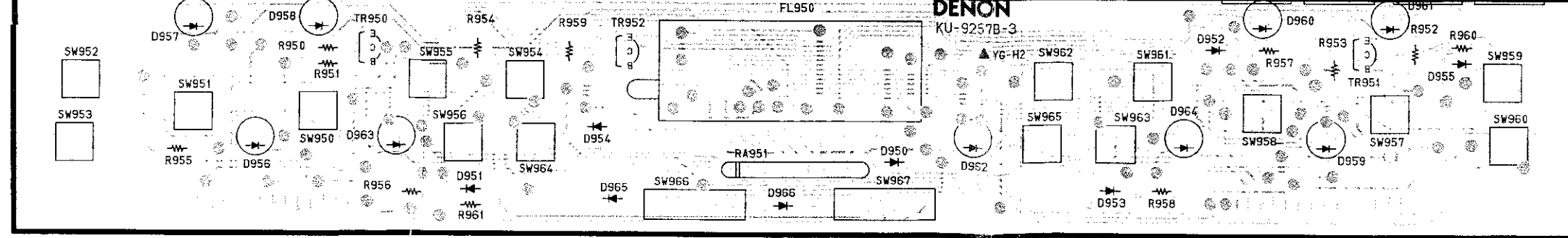
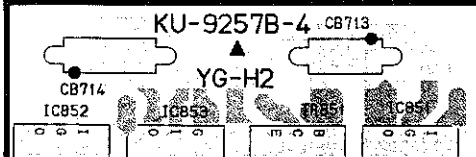
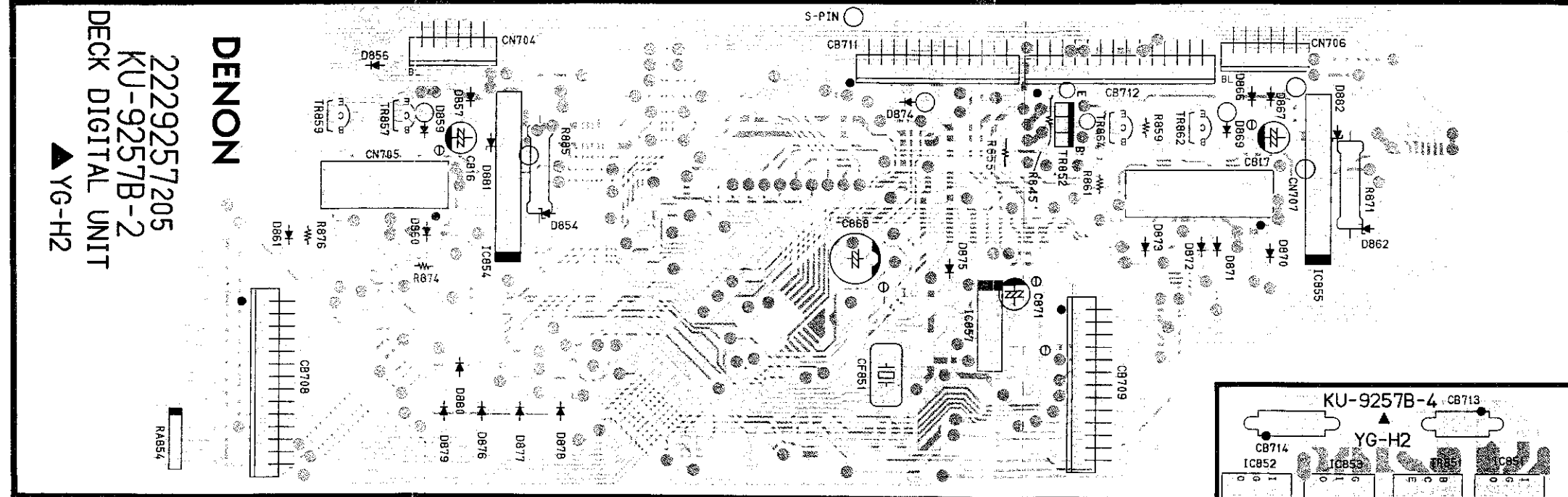

GENERAL SECTION-2

1 2 3 4 5 6 7 8

Pattern Side

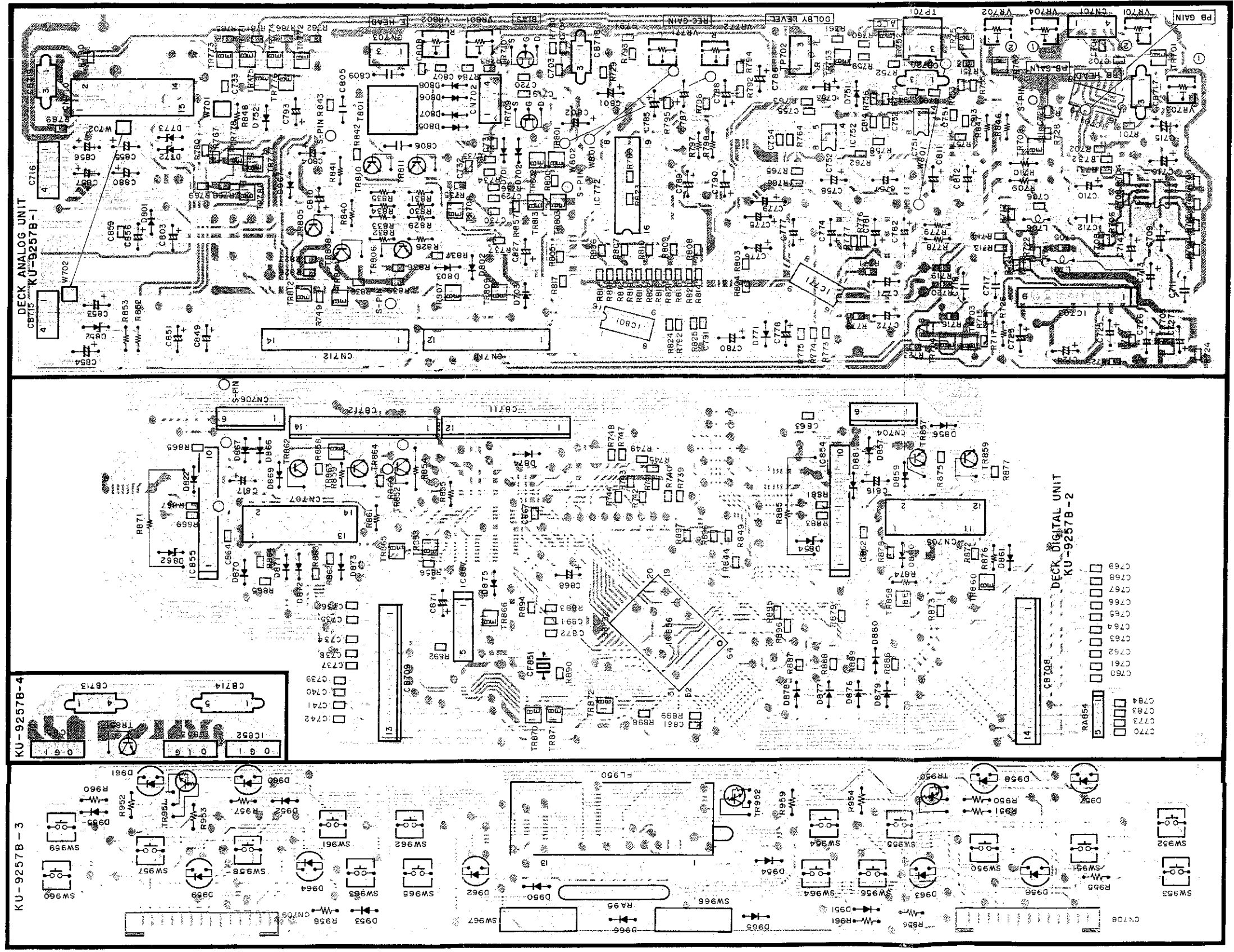

A
B
C
D
E

GENERAL SECTION-2

1 2 3 4 5 6 7 8

Component Side KU-9258B TU/EQ/CD UNIT ASS'Y

A
B
C
D
E

KU-9258B TU/EQ/CD unit 1 is divided as follows.

1	2	3	4	5
R	R	C	C	C

NOTE: R: Receiver Section
 C: CD Player Section
 KU-9258B TU/EQ/CD UNIT
 KU-9258B TUNER Unit
 KU-9258B GRA. EQ. Unit
 KU-9258B CD Unit
 KU-9258B CD CONTROL Unit
 KU-9258B CD REGULATOR Unit

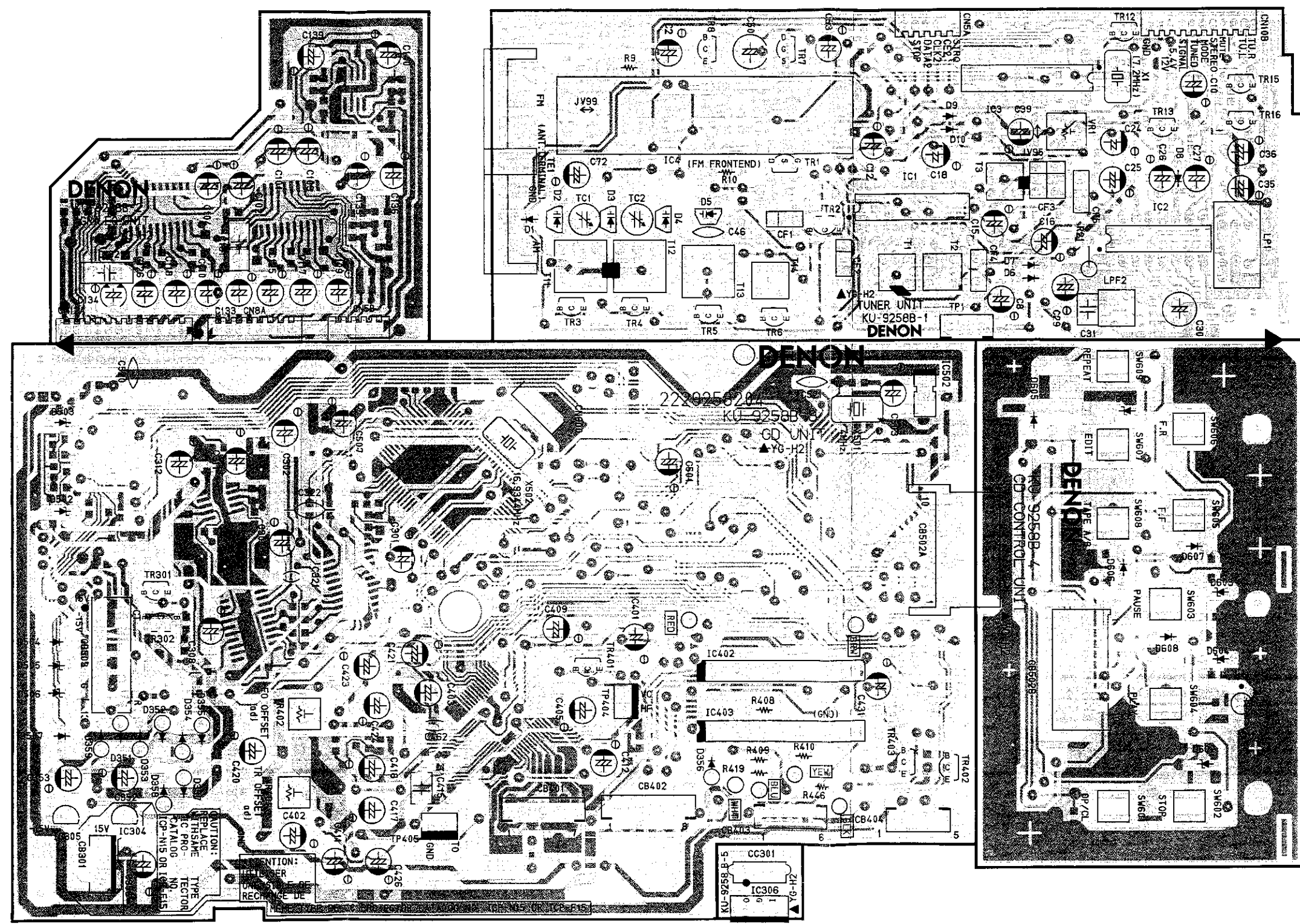

1

2

3

4

5

6

7

8

Pattern Side

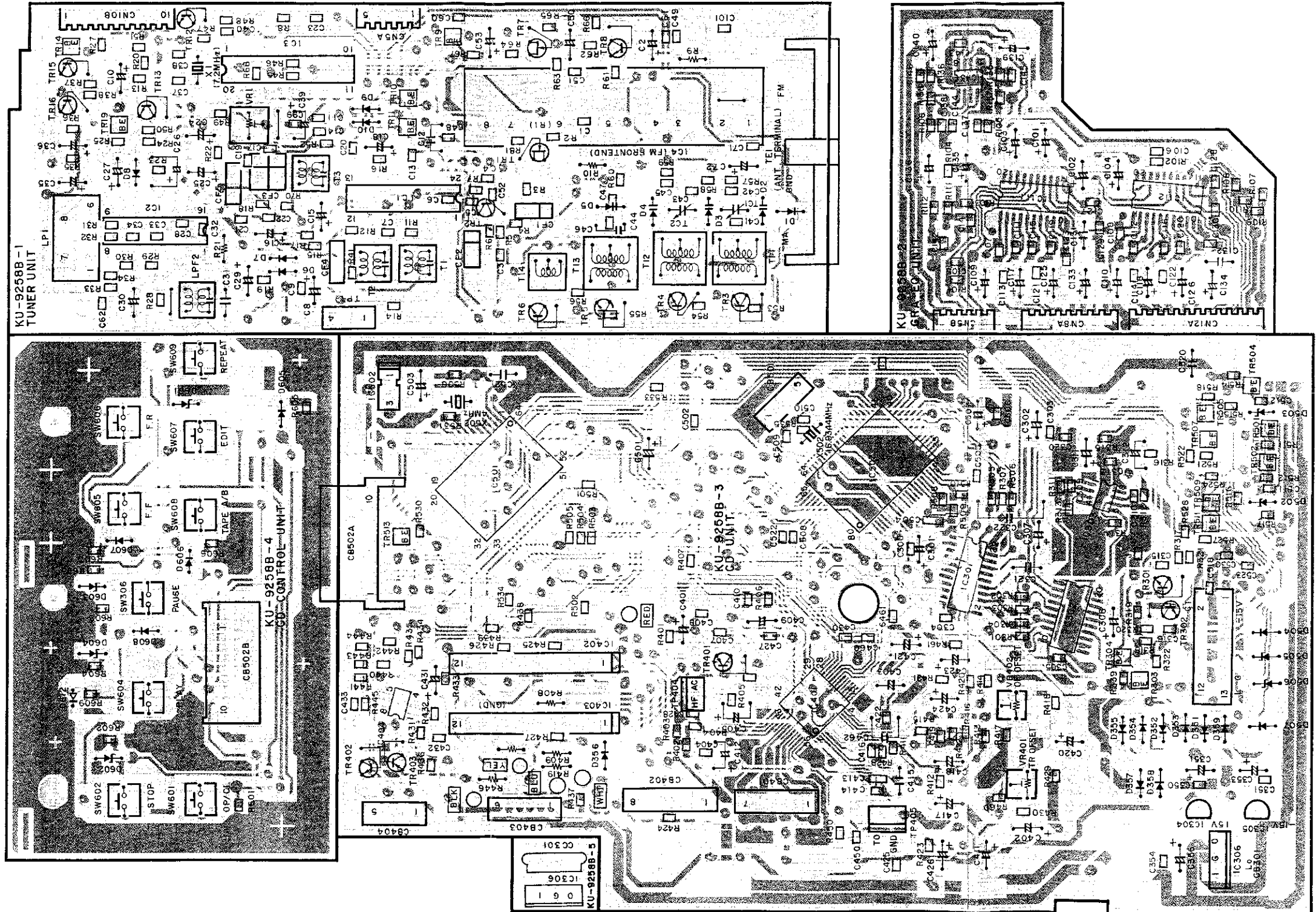

A

B

C

D

E

GENERAL SECTION-2

1 2 3 4 5 6 7 8

Component Side KU-9260B AMP UNIT ASS'Y

A

B

C

D

E

This unit is wholly used in the Receiver (Amplifier) Section.

KU-9260B AMP. UNIT

- KU-9260B-1 Amp. Unit
- KU-9260B-2 Display Unit
- KU-9260B-3 Power Supply Unit
- KU-9260B-4 Master Vol-Unit
- KU-9260B-5 None Use
- KU-9260B-6 Processor Loop Unit
- KU-9260B-7 Trans Terminal Unit
- KU-9260B-8 None Use
- KU-9260B-9 None Use

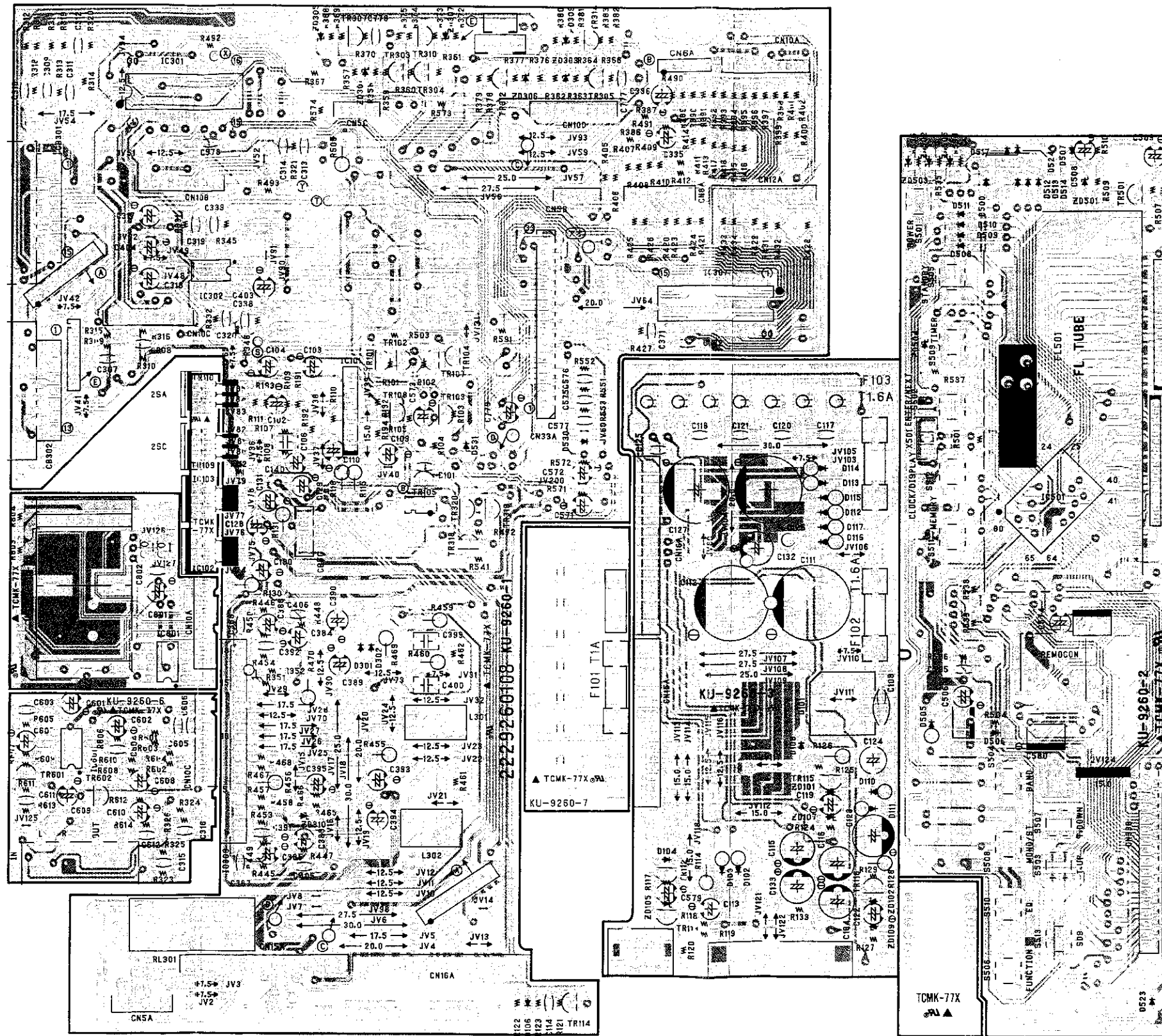

GENERAL SECTION-2

1 2 3 4 5 6 7 8

Pattern Side

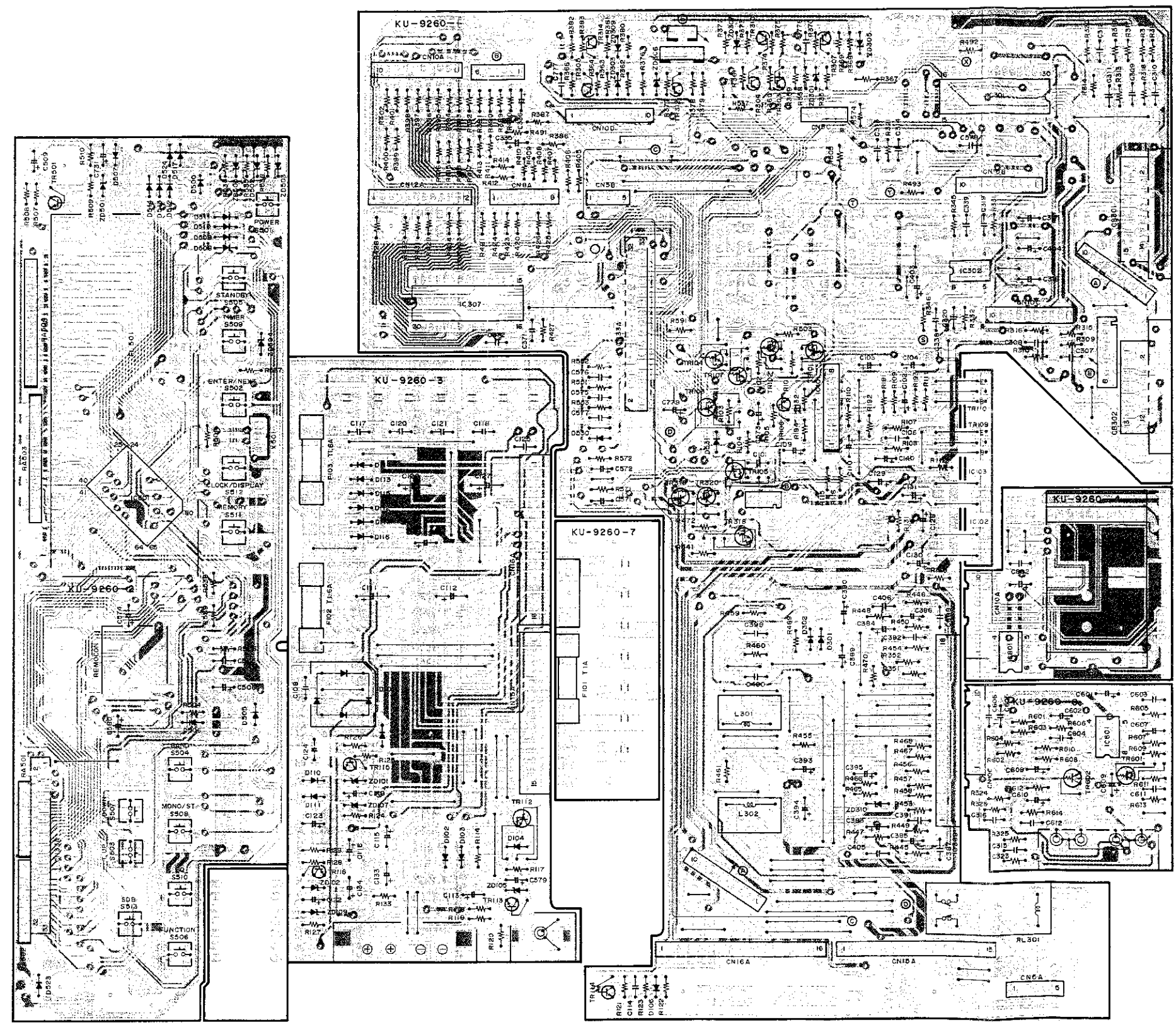

A
B
C
D
E

GENERAL SECTION-2

NOTE ON PARTS LIST

- Part indicated with the mark "⊙" are not always in stock and possibly to take a long period of time for suppling, or in some case supplying of part may be refused.
- When ordering of part, clearly indicate "1" and "1" (i) to avoid mis-supplying.
- Ordering part without stating its part number can not be supplied.
- Part indicated with the mark "★" is not illustrated in the exploded view.
- Not including Carbon Film ±5%, 1/4W Type in the P.W. Board parts list. (Refer to the Schematic Diagram for those parts.)

WARNING:

Parts marked with this symbol Δ have critical characteristics. Use ONLY replacement parts recommended by the manufacturer.

Resistors

Ex.: RN 14K 2E 182 G FR
 Type Shape and performance Power Resistance Allowable error Others

RD : Carbon Film	2B : 1/8W	F : ±1%	P : Pulse-resistant type
RC : Composition	2E : 1/4W	G : ±2%	NL : Low noise type
RS : Metallic oxide Film	2H : 1/2W	J : ±5%	NB : Non-burning type
RW : Winding	3A : 1W	K : ±10%	FR : Fuse-resistor
RN : Metal film	3D : 2W	M : ±20%	F : Lead wire forming
RK : Metal mixture	3F : 3W		
	3H : 5W		

Resistance

1 8 2 ⇒ 1800 ohm = 1.8 kohm
 Indicates number of zeros after effective number
 2-digit effective number

Units: ohm

1 R 2 ⇒ 1.2 ohm
 1-digit effective number.
 2-digit effective number, decimal point indicated by R.

Units: ohm

Capacity (electrolyte only)

2 2 R ⇒ 2200 μF
 Indicates number of zeros after effective number.
 2-digit effective number.

Units: μF

2 R 2 ⇒ 2.2 μF
 1-digit effective number.
 2-digit effective number, decimal point indicated by R.

Units: μF

Capacitors

Ex.: CE 04W 1H 2R2 M BP
 Type Shape and performance Dielectric strength Capacity Allowable error Others

CE : Aluminum foil electrolyte	0J : 6.3V	F : ±1%	HS : High stability type
CA : Aluminum solid electrolyte	1A : 10V	G : ±2%	BP : Non-polar type
CS : Tantalum electrolyte	1C : 16V	J : ±5%	HR : Ripple-resistant type
CO : Film	1E : 25V	K : ±10%	DL : For charge and discharge
CK : Ceramic	1V : 35V	M : ±20%	HF : For assuring high frequency
CC : Ceramic	1H : 50V	Z : +80%	U : UL part
CP : Oil	2A : 100V	-20%	C : CSA part
CM : Mica	2B : 125V	P : +100%	W : UL-CSA type
CF : Metallized	2C : 160V	-0%	F : Lead wire forming
CH : Metallized	2D : 200V	C : ±0.25pF	
	2E : 250V	D : ±0.5pF	
	2H : 500V	= : Others	
	2J : 630V		

Capacity (except electrolyte)

2 R 2 ⇒ 2200pF = 2200 μF = 0.002 μF
 (More than 2) Indicates number of zeros after effective number.
 2-digit effective number.

Units: μF

2 2 1 ⇒ 220pF
 (0 or 1) Indicates number of zeros after effective number.
 2-digit effective number.

Units: pF

When the dielectric strength is indicated in AC, "AC" is included after the dielectric strength value.

KU-9257B DECK UNIT PARTS LIST

Ref. No.	Part No.	Part Name	Remarks	Ref. No.	Part No.	Part Name	Remarks
SEMICONDUCTORS GROUP							
IC701	262 1211 904	IC HD14053BFP		TR872	269 0083 901	Transister DTA114EK	Chip Built in R.
IC702	263 0700 008	IC M5220FP		TR950	269 0020 906	Transister DTC114ES	Built in Resistor
IC703	263 0621 006	IC LA2000		TR951	269 0020 906	Transister DTC114ES	Built in Resistor
IC201	262 1471 003	IC M50959-35		TR952	269 0020 906	Transister DTC114ES	Built in Resistor
IC751	263 0615 902	IC BA15218F		D701	276 0432 903	Diode 1SS270A	
IC752	263 0615 902	IC BA15218F		D702	276 0432 903	Diode 1SS270A	
IC771	263 0823 008	IC HA12136AFP		D703	276 0461 903	Zener Diode HZS6A-1	6V
IC772	263 0589 009	IC CXA1198AP		D751	276 0049 914	Diode 1S2076A	
IC801	262 1266 001	IC HD14051BFP		D752	276 0432 903	Diode 1SS270A	
IC851	263 0792 003	IC NJM78M06FA (S)	Regulator +6V	D771	276 0465 925	Zener Diode HZS7B-3	7V
IC852	263 0816 002	IC NJM78M09FA (S)	Regulator +9V	D772	276 0463 914	Zener Diode HZS6C-2	6V
IC853	263 0518 009	IC NJM79M09FA	Regulator -9V	D773	276 0463 914	Zener Diode HZS6C-2	6V
IC854	263 0402 005	IC BA6209		D801	276 0049 914	Diode 1S2076A	
IC855	263 0402 005	IC BA6209		D802	276 0049 914	Diode 1S2076A	
IC856	262 1584 204	IC HD404019RB83FS	μ-Com.	D803	276 0049 914	Diode 1S2076A	
IC857	263 0822 009	IC M62005L		D805	276 0432 903	Diode 1SS270A	
TR701	269 0054 901	Transister DTC144EK	Chip Built in R.	D806	276 0432 903	Diode 1SS270A	
TR702	269 0054 901	Transister DTC144EK	Chip Built in R.	D807	276 0432 903	Diode 1SS270A	
TR703	273 0384 900	Transister 2SC2412K (S)	Chip	D808	276 0432 903	Diode 1SS270A	
TR704	273 0384 900	Transister 2SC2412K (S)	Chip	D852	276 0473 904	Zener Diode HZS12A-1	12V
TR705	273 0384 900	Transister 2SC2412K (S)	Chip	D854	276 0455 906	Zener Diode HZS4A-1	4V
TR706	269 0102 905	Transister DTC124EK	Chip Built in R.	D856	276 0432 903	Diode 1SS270A	
TR708	269 0083 901	Transister DTA114EK	Chip Built in R.	D857	276 0432 903	Diode 1SS270A	
TR709	275 0042 905	N-FET 2SK373 (Y)		D859	276 0553 905	Diode 1SR35-200A	
TR710	275 0042 905	N-FET 2SK373 (Y)		D860	276 0432 903	Diode 1SS270A	
TR751	273 0384 900	Transister 2SC2412K (S)	Chip	D861	276 0432 903	Diode 1SS270A	
TR752	273 0384 900	Transister 2SC2412K (S)	Chip	D862	276 0455 906	Zener Diode HZS4A-1	4V
TR753	273 0384 900	Transister 2SC2412K (S)	Chip	D866	276 0432 903	Diode 1SS270A	
TR771	269 0066 902	Transister DTC323TK	Chip Built in R.	D867	276 0432 903	Diode 1SS270A	
TR772	269 0066 902	Transister DTC323TK	Chip Built in R.	D869	276 0553 905	Diode 1SR35-200A	
TR773	269 0066 902	Transister DTC323TK	Chip Built in R.	D870	276 0432 903	Diode 1SS270A	
TR774	269 0066 902	Transister DTC323TK	Chip Built in R.	D871	276 0432 903	Diode 1SS270A	
TR775	269 0083 901	Transister DTA114EK	Chip Built in R.	D872	276 0432 903	Diode 1SS270A	
TR776	269 0082 902	Transister DTC114EK	Chip Built in R.	D873	276 0432 903	Diode 1SS270A	
TR777	269 0054 901	Transister DTC144EK	Chip Built in R.	D874	276 0553 905	Diode 1SR35-200A	
TR778	269 0054 901	Transister DTC144EK	Chip Built in R.	D875	276 0432 903	Diode 1SS270A	
TR780	269 0054 901	Transister DTC144EK	Chip Built in R.	D876	276 0432 903	Diode 1SS270A	
TR801	269 0066 902	Transister DTC323TK	Chip Built in R.	D877	276 0432 903	Diode 1SS270A	
TR802	269 0066 902	Transister DTC323TK	Chip Built in R.	D878	276 0432 903	Diode 1SS270A	
TR803	269 0083 901	Transister DTA114EK	Chip Built in R.	D879	276 0432 903	Diode 1SS270A	
TR804	269 0082 902	Transister DTC114EK	Chip Built in R.	D880	276 0432 903	Diode 1SS270A	
TR805	271 0192 905	Transister 2SA933S (S)		D881	276 0467 910	Zener Diode HZS9A-2	9V
TR806	271 0192 905	Transister 2SA933S (S)		D882	276 0467 910	Zener Diode HZS9A-2	9V
TR807	269 0082 902	Transister DTC114EK	Chip Built in R.	D950	276 0432 903	Diode 1SS270A	
TR808	271 0192 905	Transister 2SA933S (S)		D951	276 0432 903	Diode 1SS270A	
TR809	269 0082 902	Transister DTC114EK	Chip Built in R.	D952	276 0432 903	Diode 1SS270A	
TR810	273 0303 910	Transister 2SC1740S (S)		D953	276 0432 903	Diode 1SS270A	
TR811	273 0303 910	Transister 2SC1740S (S)		D954	276 0432 903	Diode 1SS270A	
TR812	269 0082 902	Transister DTC114EK	Chip Built in R.	D955	276 0432 903	Diode 1SS270A	
TR813	269 0082 902	Transister DTC114EK	Chip Built in R.	D956	393 9507 008	LED SLR-37MG	Green
TR851	273 0330 006	Transister 2SC3852		D957	393 9507 008	LED SLR-37MG	Green
TR852	272 0121 005	Transister 2SB1307M (Q)		D958	393 9507 008	LED SLR-37MG	Green
TR853	269 0082 902	Transister DTC114EK	Chip Built in R.	D959	393 9507 008	LED SLR-37MG	Green
TR857	272 0025 907	Transister 2SB562 (C)		D960	393 9507 008	LED SLR-37MG	Green
TR858	269 0088 906	Transister DTC114TK	Chip Built in R.	D961	393 9507 008	LED SLR-37MG	Green
TR859	272 0025 907	Transister 2SB562 (C)		D962	393 9508 007	LED SLR-37VR	Red
TR860	269 0088 906	Transister DTC114TK	Chip Built in R.	D963	393 9508 007	LED SLR-37VR	Red
TR862	272 0025 907	Transister 2SB562 (C)		D964	393 9508 007	LED SLR-37VR	Red
TR863	269 0088 906	Transister DTC114TK	Chip Built in R.	D965	276 0432 903	Diode 1SS270A	
TR864	272 0025 907	Transister 2SB562 (C)		D966	276 0432 903	Diode 1SS270A	
TR865	269 0088 906	Transister DTC114TK	Chip Built in R.	D967	276 0432 903	Diode 1SS270A	
TR870	269 0083 901	Transister DTA114EK	Chip Built in R.	RESISTORS GROUP (Not included Carbon Film ±5%, 1/4W Type. Refer to the Schematic Diagram for those parts.)			
TR871	269 0083 901	Transister DTA114EK	Chip Built in R.	R701	247 0011 960	Chip Carbon 56k ohm 1/10W	RM73B--56J
				R702	247 0011 960	Chip Carbon 56k ohm 1/10W	RM73B--56J

GENERAL SECTION-2

Ref. No.	Part No.	Part Name	Remarks	Ref. No.	Part No.	Part Name	Remarks
R703	247 0005 905	Chip Carbon 100 ohm 1/10W	RM73B--101J	R774	247 0010 961	Chip Carbon 22k ohm 1/10W	RM73B--223J
R704	247 0005 905	Chip Carbon 100 ohm 1/10W	RM73B--101J	R775	247 0009 985	Chip Carbon 10k ohm 1/10W	RM73B--103J
R705	247 0013 926	Chip Carbon 270k ohm 1/10W	RM73B--274J	R776	247 0012 927	Chip Carbon 100k ohm 1/10W	RM73B--104J
R706	247 0013 926	Chip Carbon 270k ohm 1/10W	RM73B--274J	R777	247 0009 985	Chip Carbon 10k ohm 1/10W	RM73B--103J
R707	247 0010 945	Chip Carbon 18k ohm 1/10W	RM73B--183J	R780	247 0009 985	Chip Carbon 10k ohm 1/10W	RM73B--103J
R708	247 0010 945	Chip Carbon 18k ohm 1/10W	RM73B--183J	R781	247 0007 974	Chip Carbon 1.3k ohm 1/10W	RM73B--132J
R711	247 0008 960	Chip Carbon 3.3k ohm 1/10W	RM73B--332J	R782	247 0007 974	Chip Carbon 1.3k ohm 1/10W	RM73B--132J
R712	247 0008 960	Chip Carbon 3.3k ohm 1/10W	RM73B--332J	R783	247 0010 945	Chip Carbon 18k ohm 1/10W	RM73B--183J
R713	247 0009 914	Chip Carbon 5.1k ohm 1/10W	RM73B--512J	R784	247 0010 945	Chip Carbon 18k ohm 1/10W	RM73B--183J
R714	247 0009 914	Chip Carbon 5.1k ohm 1/10W	RM73B--512J	R785	247 0007 945	Chip Carbon 1k ohm 1/10W	RM73B--102J
R715	247 0009 956	Chip Carbon 7.5k ohm 1/10W	RM73B--752J	R786	247 0007 945	Chip Carbon 1k ohm 1/10W	RM73B--102J
R716	247 0009 956	Chip Carbon 7.5k ohm 1/10W	RM73B--752J	R789	247 0005 905	Chip Carbon 100 ohm 1/10W	RM73B--101J
R717	247 0014 967	Chip Carbon 1M ohm 1/10W	RM73B--105J	R790	247 0005 905	Chip Carbon 100 ohm 1/10W	RM73B--101J
R718	247 0014 967	Chip Carbon 1M ohm 1/10W	RM73B--105J	R791	247 0009 985	Chip Carbon 10k ohm 1/10W	RM73B--103J
R719	247 0007 945	Chip Carbon 1k ohm 1/10W	RM73B--102J	R792	247 0009 985	Chip Carbon 10k ohm 1/10W	RM73B--103J
R720	247 0007 945	Chip Carbon 1k ohm 1/10W	RM73B--102J	R793	247 0009 927	Chip Carbon 5.6k ohm 1/10W	RM73B--562J
R721	247 0011 944	Chip Carbon 47k ohm 1/10W	RM73B--473J	R794	247 0009 927	Chip Carbon 5.6k ohm 1/10W	RM73B--562J
R722	247 0011 944	Chip Carbon 47k ohm 1/10W	RM73B--473J	R795	247 0009 927	Chip Carbon 5.6k ohm 1/10W	RM73B--562J
R723	247 0010 961	Chip Carbon 22k ohm 1/10W	RM73B--223J	R796	247 0009 927	Chip Carbon 5.6k ohm 1/10W	RM73B--562J
R724	247 0011 960	Chip Carbon 56k ohm 1/10W	RM73B--563J	R799	247 0010 974	Chip Carbon 24k ohm 1/10W	RM73B--243J
R725	247 0009 985	Chip Carbon 10k ohm 1/10W	RM73B--103J	R800	247 0007 945	Chip Carbon 1k ohm 1/10W	RM73B--102J
R727	247 0010 990	Chip Carbon 30k ohm 1/10W	RM73B--303J	R803	247 0009 985	Chip Carbon 10k ohm 1/10W	RM73B--103J
R728	247 0009 985	Chip Carbon 10k ohm 1/10W	RM73B--103J	R804	247 0009 985	Chip Carbon 10k ohm 1/10W	RM73B--103J
R729	247 0012 927	Chip Carbon 100k ohm 1/10W	RM73B--104J	R805	247 0012 969	Chip Carbon 150k ohm 1/10W	RM73B--154J
R730	247 0012 927	Chip Carbon 100k ohm 1/10W	RM73B--104J	R806	247 0012 956	Chip Carbon 130k ohm 1/10W	RM73B--134J
R731	247 0011 944	Chip Carbon 47k ohm 1/10W	RM73B--473J	R807	247 0011 986	Chip Carbon 68k ohm 1/10W	RM73B--683J
R732	247 0009 901	Chip Carbon 4.7k ohm 1/10W	RM73B--472J	R808	247 0010 974	Chip Carbon 24k ohm 1/10W	RM73B--243J
R733	247 0015 940	Chip Carbon 2.2M ohm 1/10W	RM73B--225J	R809	247 0011 944	Chip Carbon 47k ohm 1/10W	RM73B--473J
R734	247 0015 940	Chip Carbon 2.2M ohm 1/10W	RM73B--225J	R810	247 0010 961	Chip Carbon 22k ohm 1/10W	RM73B--223J
R735	247 0009 985	Chip Carbon 10k ohm 1/10W	RM73B--103J	R811	247 0011 986	Chip Carbon 68k ohm 1/10W	RM73B--683J
R736	247 0012 927	Chip Carbon 100k ohm 1/10W	RM73B--104J	R812	247 0011 957	Chip Carbon 51k ohm 1/10W	RM73B--513J
R737	247 0007 945	Chip Carbon 1k ohm 1/10W	RM73B--102J	R813	247 0012 943	Chip Carbon 120k ohm 1/10W	RM73B--124J
R739	247 0009 985	Chip Carbon 10k ohm 1/10W	RM73B--103J	R814	247 0011 957	Chip Carbon 51k ohm 1/10W	RM73B--513J
R740	247 0009 901	Chip Carbon 4.7k ohm 1/10W	RM73B--472J	R815	247 0011 986	Chip Carbon 68k ohm 1/10W	RM73B--683J
R741	247 0009 901	Chip Carbon 4.7k ohm 1/10W	RM73B--472J	R816	247 0012 901	Chip Carbon 82k ohm 1/10W	RM73B--823J
R742	247 0009 901	Chip Carbon 4.7k ohm 1/10W	RM73B--472J	R817	247 0012 998	Chip Carbon 200k ohm 1/10W	RM73B--204J
R743	247 0009 901	Chip Carbon 4.7k ohm 1/10W	RM73B--472J	R818	247 0011 957	Chip Carbon 51k ohm 1/10W	RM73B--513J
R744	247 0009 901	Chip Carbon 4.7k ohm 1/10W	RM73B--472J	R819	247 0012 927	Chip Carbon 100k ohm 1/10W	RM73B--104J
R745	247 0009 901	Chip Carbon 4.7k ohm 1/10W	RM73B--472J	R820	247 0011 957	Chip Carbon 51k ohm 1/10W	RM73B--513J
R746	247 0009 901	Chip Carbon 4.7k ohm 1/10W	RM73B--472J	R821	247 0012 930	Chip Carbon 110k ohm 1/10W	RM73B--114J
R747	247 0009 985	Chip Carbon 10k ohm 1/10W	RM73B--103J	R822	247 0012 914	Chip Carbon 91k ohm 1/10W	RM73B--913J
R748	247 0009 985	Chip Carbon 10k ohm 1/10W	RM73B--103J	R823	247 0012 927	Chip Carbon 100k ohm 1/10W	RM73B--104J
R749	247 0009 985	Chip Carbon 10k ohm 1/10W	RM73B--103J	R824	247 0009 901	Chip Carbon 4.7k ohm 1/10W	RM73B--472J
R751	247 0011 986	Chip Carbon 68k ohm 1/10W	RM73B--683J	R825	247 0009 901	Chip Carbon 4.7k ohm 1/10W	RM73B--472J
R752	247 0011 986	Chip Carbon 68k ohm 1/10W	RM73B--683J	R826	247 0007 945	Chip Carbon 1k ohm 1/10W	RM73B--102J
R753	247 0008 944	Chip Carbon 2.7k ohm 1/10W	RM73B--272J	R827	247 0008 960	Chip Carbon 3.3k ohm 1/10W	RM73B--332J
R754	247 0008 944	Chip Carbon 2.7k ohm 1/10W	RM73B--272J	R836	247 0007 945	Chip Carbon 1k ohm 1/10W	RM73B--102J
R755	247 0009 972	Chip Carbon 9.1k ohm 1/10W	RM73B--912J	R837	247 0008 960	Chip Carbon 3.3k ohm 1/10W	RM73B--332J
R756	247 0009 972	Chip Carbon 9.1k ohm 1/10W	RM73B--912J	R838	247 0007 945	Chip Carbon 1k ohm 1/10W	RM73B--102J
R757	247 0010 990	Chip Carbon 30k ohm 1/10W	RM73B--303J	R839	247 0008 960	Chip Carbon 3.3k ohm 1/10W	RM73B--332J
R758	247 0010 990	Chip Carbon 30k ohm 1/10W	RM73B--303J	R842	247 0001 983	Chip Carbon 4.7 ohm 1/10W	RM73B--4R7K
R759	247 0009 901	Chip Carbon 4.7k ohm 1/10W	RM73B--472J	R843	247 0010 903	Chip Carbon 12k ohm 1/10W	RM73B--123J
R760	247 0009 901	Chip Carbon 4.7k ohm 1/10W	RM73B--472J	R844	247 0009 985	Chip Carbon 10k ohm 1/10W	RM73B--103J
R761	247 0005 905	Chip Carbon 100 ohm 1/10W	RM73B--101J	R845	247 0009 901	Chip Carbon 4.7k ohm 1/10W	RM73B--472J
R762	247 0004 922	Chip Carbon 47 ohm 1/10W	RM73B--470J	R856	247 0007 945	Chip Carbon 1k ohm 1/10W	RM73B--102J
R763	247 0009 985	Chip Carbon 10k ohm 1/10W	RM73B--103J	R857	247 0009 985	Chip Carbon 10k ohm 1/10W	RM73B--103J
R764	247 0012 985	Chip Carbon 180k ohm 1/10W	RM73B--184J	R858	247 0009 985	Chip Carbon 10k ohm 1/10W	RM73B--103J
R765	247 0009 985	Chip Carbon 10k ohm 1/10W	RM73B--103J	R860	247 0009 985	Chip Carbon 10k ohm 1/10W	RM73B--103J
R766	247 0009 985	Chip Carbon 10k ohm 1/10W	RM73B--103J	R862	247 0009 985	Chip Carbon 10k ohm 1/10W	RM73B--103J
R767	247 0009 985	Chip Carbon 10k ohm 1/10W	RM73B--103J	R863	247 0010 990	Chip Carbon 30k ohm 1/10W	RM73B--303J
R768	247 0009 985	Chip Carbon 10k ohm 1/10W	RM73B--103J	R864	247 0009 985	Chip Carbon 10k ohm 1/10W	RM73B--103J
R769	247 0009 985	Chip Carbon 10k ohm 1/10W	RM73B--103J	R865	247 0010 990	Chip Carbon 30k ohm 1/10W	RM73B--303J
R771	247 0007 945	Chip Carbon 1k ohm 1/10W	RM73B--102J	R867	247 0007 945	Chip Carbon 1k ohm 1/10W	RM73B--102J
R772	247 0007 945	Chip Carbon 1k ohm 1/10W	RM73B--102J	R869	247 0007 945	Chip Carbon 1k ohm 1/10W	RM73B--102J
R773	247 0010 945	Chip Carbon 18k ohm 1/10W	RM73B--183J	R872	247 0009 985	Chip Carbon 10k ohm 1/10W	RM73B--103J

GENERAL SECTION-2

Ref. No.	Part No.	Part Name	Remarks	Ref. No.	Part No.	Part Name	Remarks
R873	247 0010 990	Chip Carbon 30k ohm 1/10W	RM73B--303J	C729	257 0008 983	Chip Ceramic 1000pF/50V	CK73B1H102K
R875	247 0009 985	Chip Carbon 10k ohm 1/10W	RM73B--103J	C730	257 0012 966	Chip Ceramic 0.01µF/50V	CK73F1H103Z
R877	247 0009 985	Chip Carbon 20k ohm 1/10W	RM73B--103J	C731	257 0008 983	Chip Ceramic 1000pF/50V	CK73B1H102K
R878	247 0009 985	Chip Carbon 10k ohm 1/10W	RM73B--103J	C732	257 0008 983	Chip Ceramic 1000pF/50V	CK73B1H102K
R879	247 0010 990	Chip Carbon 30k ohm 1/10W	RM73B--303J	C733	257 0014 935	Chip Ceramic 0.1µF/25V	CK73F1E104Z
R881	247 0007 945	Chip Carbon 1k ohm 1/10W	RM73B--102J	C751	257 0005 902	Chip Ceramic 150pF/50V	CC73SL1H151J
R883	247 0007 945	Chip Carbon 1k ohm 1/10W	RM73B--102J	C752	257 0005 902	Chip Ceramic 150pF/50V	CC73SL1H151J
R886	247 0011 944	Chip Carbon 47k ohm 1/10W	RM73B--473J	C753	254 4302 932	Electrolytic 22µF/10V	CE04W1A220M (SRE)
R887	247 0011 944	Chip Carbon 47k ohm 1/10W	RM73B--473J	C754	257 0004 961	Chip Ceramic 100pF/50V	CC73SL1H101J
R888	247 0011 944	Chip Carbon 47k ohm 1/10W	RM73B--473J	C755	257 0004 961	Chip Ceramic 100pF/50V	CC73SL1H101J
R889	247 0011 944	Chip Carbon 47k ohm 1/10W	RM73B--473J	C757	254 4304 927	Electrolytic 4.7µF/35V	CE04W1V4R7M (SRE)
R890	247 0014 967	Chip Carbon 1M ohm 1/10W	RM73B--105J	C758	254 4304 927	Electrolytic 4.7µF/35V	CE04W1V4R7M (SRE)
R892	247 0009 985	Chip Carbon 10k ohm 1/10W	RM73B--103J	C771	254 4305 968	Electrolytic 1µF/50V	CE04W1H010M (SRE)
R893	247 0009 985	Chip Carbon 10k ohm 1/10W	RM73B--103J	C772	254 4305 968	Electrolytic 1µF/50V	CE04W1H010M (SRE)
R894	247 0009 985	Chip Carbon 10k ohm 1/10W	RM73B--103J	C774	254 4299 906	Electrolytic 100µF/16V	CE04W1C100M (SRE)
R895	247 0009 985	Chip Carbon 10k ohm 1/10W	RM73B--103J	C775	254 4304 927	Electrolytic 4.7µF/35V	CE04W1V4R7M (SRE)
R896	247 0009 985	Chip Carbon 10k ohm 1/10W	RM73B--103J	C776	254 4304 927	Electrolytic 4.7µF/35V	CE04W1V4R7M (SRE)
R897	247 0009 985	Chip Carbon 10k ohm 1/10W	RM73B--103J	C777	254 4305 926	Electrolytic 0.22µF/50V	CE04W1HR22M (SRE)
R898	247 0009 985	Chip Carbon 10k ohm 1/10W	RM73B--103J	C778	254 4305 926	Electrolytic 0.22µF/50V	CE04W1HR22M (SRE)
R899	247 0011 944	Chip Carbon 47k ohm 1/10W	RM73B--473J	C779	254 4304 927	Electrolytic 4.7µF/35V	CE04W1V4R7M (SRE)
R901	247 0008 928	Chip Carbon 2.2k ohm 1/10W	RM73B--222J	C780	254 4304 927	Electrolytic 4.7µF/35V	CE04W1V4R7M (SRE)
R902	247 0008 928	Chip Carbon 2.2k ohm 1/10W	RM73B--222J	C781	254 4302 974	Electrolytic 100µF/10V	CE04W1A101M (SRE)
R903	247 0008 928	Chip Carbon 2.2k ohm 1/10W	RM73B--222J	C782	254 4302 974	Electrolytic 100µF/10V	CE04W1A101M (SRE)
R904	247 0008 928	Chip Carbon 2.2k ohm 1/10W	RM73B--222J	C785	254 4305 942	Electrolytic 0.47µF/50V	CE04W1HR47M (SRE)
△R797	241 2377 921	Carbon Film 82 ohm 1/4W (NB)	RD14B2E820JNBS	C786	254 4305 942	Electrolytic 0.47µF/50V	CE04W1HR47M (SRE)
△R798	241 2377 921	Carbon Film 82 ohm 1/4W (NB)	RD14B2E820JNBS	C787	254 4304 927	Electrolytic 4.7µF/35V	CE04W1V4R7M (SRE)
△R840	241 2375 907	Carbon Film 10 ohm 1/4W (NB)	RD14B2E100JNBS	C788	254 4304 927	Electrolytic 4.7µF/35V	CE04W1V4R7M (SRE)
△R841	241 2375 907	Carbon Film 10 ohm 1/4W (NB)	RD14B2E100JNBS	C789	254 4302 974	Electrolytic 100µF/10V	CE04W1A101M (SRE)
△R871	244 0074 021	Metal Oxide 10 ohm 2W	RS14B3D100JNBF	C790	254 4302 974	Electrolytic 100µF/10V	CE04W1A101M (SRE)
△R885	244 0074 021	Metal Oxide 10 ohm 2W	RS14B3D100JNBF	C791	257 0012 966	Chip Ceramic 0.01µF/50V	CK73F1H103Z
VR701,702	211 8005 021	Semi Fixed 4.7k ohm	V06QB472	C792	257 0012 966	Chip Ceramic 0.01µF/50V	CK73F1H103Z
VR703,704	211 6070 003	Semi Fixed 1k ohm	V06QB472	C793	254 4302 974	Electrolytic 100µF/10V	CE04W1A101M (SRE)
VR771,772	211 6070 029	Semi Fixed 10 k ohm	V06QB103	C794	257 0008 941	Chip Ceramic 470pF/50V	CK73B1H471K
VR801,802	211 8005 005	Semi Fixed 47 k ohm	V06QB473	C795	257 0008 941	Chip Ceramic 470pF/50V	CK73B1H471K
RA951	246 2079 004	Resistor Array 47k ohm×11	RK99=2B473JP11 (S)	C801	254 4304 927	Electrolytic 4.7µF/35V	CE04W1V4R7M (SRE)
CAPACITORS GROUP				C802	254 4304 927	Electrolytic 4.7µF/35V	CE04W1V4R7M (SRE)
C701	257 0006 927	Chip Ceramic 470pF/50V	CC73SL1H471J	C803	254 4300 963	Electrolytic 100µF/6.3V	CE04W0J101M (SRE)
C702	257 0006 927	Chip Ceramic 470pF/50V	CC73SL1H471J	C804	254 4256 949	Electrolytic 100µF/25V	CE04W1E101M
C703	257 0005 986	Chip Ceramic 330pF/50V	CC73SL1H331J	C805	255 1210 907	Plastic Film 0.0068µF/50V	CQ93M1H682J
C704	257 0005 986	Chip Ceramic 330pF/50V	CC73SL1H331J	C806	256 1034 979	Metalized 0.1µF/50V	CF93A1H104J
C705	257 0005 902	Chip Ceramic 150pF/50V	CC73SL1H151J	C807	257 0005 944	Chip Ceramic 220pF/50V	CC73SL1H221J
C706	257 0005 902	Chip Ceramic 150pF/50V	CC73SL1H151J	C808	257 0005 944	Chip Ceramic 220pF/50V	CC73SL1H221J
C707	257 0004 961	Chip Ceramic 470pF/50V	CC73SL1H101J	C809	255 1253 003	Plastic Film 0.01µF/200V	CQ92M201 03J
C708	257 0004 961	Chip Ceramic 470pF/50V	CC73SL1H101J	C810	254 4304 943	Electrolytic 10µF/35V	CE04W1V100M (SRE)
C709	254 4300 963	Electrolytic 100µF/6.3V	CE04W0J101M (SRE)	C811	254 4299 906	Electrolytic 10µF/16V	CE04W1C100M (SRE)
C710	254 4300 963	Electrolytic 100µF/6.3V	CE04W0J101M (SRE)	C812	254 4299 906	Electrolytic 10µF/16V	CE04W1C100M (SRE)
C711	255 1256 903	Plastic Film 0.0075µF/50V	CQ93M1H752J (MRZ)	C813	257 0003 988	Chip Ceramic 47pF/50V	CC73SL1H470J
C712	255 1256 903	Plastic Film 0.0075µF/50V	CQ93M1H752J (MRZ)	C814	257 0003 988	Chip Ceramic 47pF/50V	CC73SL1H470J
C713	254 4304 927	Electrolytic 4.7µF/35V	CE04W1V4R7M (SRE)	C816	254 4193 947	Electrolytic 100µF/16V	CE04W1C101M (SRA)
C714	254 4304 927	Electrolytic 4.7µF/35V	CE04W1V4R7M (SRE)	C817	254 4193 947	Electrolytic 100µF/16V	CE04W1C101M (SRA)
C715	254 4302 958	Electrolytic 47µF/10V	CE04W1A470M (SRE)	C849	254 4305 984	Electrolytic 2.2µF/50V	CE04W1HR22M (SRE)
C716	254 4302 958	Electrolytic 47µF/10V	CE04W1A470M (SRE)	C851	254 4303 957	Electrolytic 22µF/25V	CE04W1E220M (SRE)
C717	255 1212 905	Plastic Film 0.01µF/50V	CQ93M1H103J	C853	254 4299 964	Electrolytic 47µF/16V	CE04W1C470M (SRE)
C718	255 1212 905	Plastic Film 0.01µF/50V	CQ93M1H103J	C854	254 4193 947	Electrolytic 100µF/16V	CE04W1C101M (SRA)
C719	257 0003 988	Chip Ceramic 47pF/50V	CC73SL1H470J	C855	254 4303 931	Electrolytic 10µF/25V	CE04W1E100M (SRE)
C720	257 0003 988	Chip Ceramic 47pF/50V	CC73SL1H470J	C856	254 4299 906	Electrolytic 10µF/16V	CE04W1C100M (SRE)
C721	257 0012 966	Chip Ceramic 0.01µF/50V	CK73F1H103Z	C857	254 4303 931	Electrolytic 10µF/25V	CE04W1E100M (SRE)
C722	254 4302 974	Electrolytic 100µF/10V	CE04W1A101M (SRE)	C858	254 4254 080	Electrolytic 1000µF/16V	CE04W1C102M
C723	254 4302 974	Electrolytic 100µF/10V	CE04W1A101M (SRE)	C859	257 0012 966	Chip Ceramic 0.01µF/50V	CK73F1H103Z
C724	254 4305 900	Electrolytic 0.1µF/50V	CE04W1H0R1M (SRE)	C860	254 4299 906	Electrolytic 10µF/16V	CE04W1C100M (SRE)
C725	254 4305 900	Electrolytic 0.1µF/50V	CE04W1H0R1M (SRE)	C861	257 0008 983	Chip Ceramic 1000pF/50V	CK73B1H102K
C726	254 4305 968	Electrolytic 1µF/50V	CE04W1H010M (SRE)	C862	257 0014 935	Chip Ceramic 0.1µF/25V	CK73F1E104Z
C727	254 4305 968	Electrolytic 1µF/50V	CE04W1H010M (SRE)	C863	257 0014 935	Chip Ceramic 0.1µF/25V	CK73F1E104Z
C728	254 4302 974	Electrolytic 100µF/10V	CE04W1A101M (SRE)	C864	257 0014 935	Chip Ceramic 0.1µF/25V	CK73F1E104Z
				C865	257 0014 935	Chip Ceramic 0.1µF/25V	CK73F1E104Z

GENERAL SECTION-2

KU-9258B-1,2 TUNER, EQ SECTION PARTS LIST

Ref. No.	Part No.	Part Name	Remarks	Ref. No.	Part No.	Part Name	Remarks
C866	257 0012 966	Chip Ceramic 0.01µF/50V	CK73F1H103Z	SEMICONDUCTORS GROUP			
C867	257 0012 966	Chip Ceramic 0.01µF/50V	CK73F1H103Z				
C868	254 4327 904	Electrolytic 1000µF/6.3V	CE04W0J102M (SRE)				
C871	254 4305 023	Electrolytic 0.22µF/50V	CE04W1HR22M (SRE)				
OTHER GROUP				Q'ty			
L701,702	—	(P.W.Board)		IC001	263 0421 002	IC LA1267	
	235 0020 945	Inductor 153J		IC002	263 0584 004	IC LA3410	
	212 5604 910	Tact Switch		IC003	262 0703 002	IC LM7000	
CF851	399 9018 003	Ceramic Vibrator	CST4.00 MGW	IC201	262 1471 003	IC M50959-359SP	
T801	231 9805 004	105 kHz OSC Coil		IC004	216 0079 005	FM Front End	
SW966	212 4423 008	Slide Switch		IC111	263 0699 902	IC LA3607M-TP	
SW967	212 9504 003	Slide Switch		IC112	263 0699 902	IC LA3607M-TP	
FL950	393 4135 006	FLD FIP4H5		IC113	263 0615 902	IC BA15218F	
	461 0496 026	Spacer		TR001	275 0051 909	N-FET 2SK161 (GR)	
TP701	205 0355 033	3P KR Conn. Base (L)		TR002	273 0025 926	Transister 2SC461 (C)	
TP702	205 0546 033	3P Pin Post		TR003	273 0317 906	Transister 2SC2458 (BL)	
CB717,718 719,720	205 0409 031	3P Dip Socket		TR004	273 0317 906	Transister 2SC2458 (BL)	
CB713	205 0409 044	4P Dip Socket		TR005	273 0317 906	Transister 2SC2458 (BL)	
CB714	205 0409 057	5P Dip Socket		TR006	273 0317 906	Transister 2SC2458 (BL)	
CN705	205 0553 026	12P Trap Conn. Base		TR007	275 0053 907	N-FET 2SK365 (BL/GR)	
CN710	205 0554 054	15P Trap Conn. Base		TR008	273 0317 906	Transister 2SC2458 (BL)	
CN707	205 0554 041	14P Trap Conn. Base		TR009	269 0055 900	Transister DTA144EK	Chip Built in R.
CN703	205 0343 032	3P Conn. Base (KR-PH)		TR010	269 0055 900	Transister DTA144EK	Chip Built in R.
CN701,702	205 0343 045	4P Conn. Base (KR-PH)		TR011	269 0055 900	Transister DTA144EK	Chip Built in R.
CB715	205 0343 045	4P Conn. Base (KR-PH)		TR012	273 0317 906	Transister 2SC2458 (BL)	
CB716	205 0343 058	5P Conn. Base (KR-PH)		TR013	273 0317 906	Transister 2SC2458 (BL)	
CN711	205 0375 026	12P Conn. Base (KR-PH)		TR014	269 0055 900	Transister DTA144EK	Chip Built in R.
CN709	205 0375 039	13P Conn. Base (KR-PH)		TR015	273 0317 906	Transister 2SC2458 (BL)	
CN708~712	205 0375 042	14P Conn. Base (KR-PH)		TR016	273 0317 906	Transister 2SC2458 (BL)	
	203 6379 017	4P PH Conn. Cord		TR019	269 0054 901	Transister DTC144EK	Chip Built in R.
CB713	203 6379 004	4P PH Conn. Cord		D001	276 0432 903	Diode 1SS270A	
CB714	203 8337 002	5P PH Conn. Cord		D002	276 0302 004	Varactor SVC321SPA-D-2	
CN704~706	204 0370 002	5P PH-SAN Conn. Cord		D003	276 0302 004	Varactor SVC321SPA-D-2	
CB711	204 6343 004	12P KR-DS Conn. Cord		D004	276 0302 004	Varactor SVC321SPA-D-2	
CB709	204 6340 007	13P KR-DS Conn. Cord		D005	276 0302 004	Varactor SVC321SPA-D-2	
CB708	204 6341 006	14P KR-DS Conn. Cord		D006	276 0432 903	Diode 1SS270A	
CB712	204 6342 005	14P KR-DS Conn. Cord		D007	276 0432 903	Diode 1SS270A	
W801,802 803	209 0220 063	Vinyle Wire	L=50	D008	276 0432 903	Diode 1SS270A	
W702	209 0220 050	Vinyle Wire	L=90	D009	276 0432 903	Diode 1SS270A	
	001 9052 007	Vinyle Wire Gray	L=30	D010	276 0432 903	Diode 1SS270A	
W701	203 0307 001	1P Connector Cord	L=100	RESISTORS GROUP (Not included Carbon Film ±5% 1/4W Type. Refer to the Schematic Diagram for these Parts.)			
CB717,718	204 0009 014	2C Shield Wire	L=150	R002	247 0006 920	Chip Carbon 330 ohm 1/10W	RM 73B--331J
CB719,720	204 0009 027	2C Shield Wire	L=240	R003	247 0006 920	Chip Carbon 330 ohm 1/10W	RM 73B--331J
	205 0452 017	Style Pin		R004	247 0005 989	Chip Carbon 220 ohm 1/10W	RM 73B--221J
				R005	247 0009 901	Chip Carbon 4.7k ohm 1/10W	RM 73B--472J
				R006	247 0006 920	Chip Carbon 330 ohm 1/10W	RM 73B--331J
				R007	247 0005 989	Chip Carbon 220 ohm 1/10W	RM 73B--221J
				R008	247 0006 962	Chip Carbon 470 ohm 1/10W	RM 73B--471J
				R009	241 2400 995	Carbon Film 10k ohm 1/4W	RD 14B2E103J (5)
				R010	241 2401 978	Carbon Film 22k ohm 1/4W	RD 14B2E223J (5)
				R011	247 0010 961	Chip Carbon 22k ohm 1/10W	RM 73B--223J
				R012	247 0004 980	Chip Carbon 82 ohm 1/10W	RM 73B--820J
				R013	247 0009 927	Chip Carbon 5.6k ohm 1/10W	RM 73B--562J
				R014	247 0010 987	Chip Carbon 27k ohm 1/10W	RM 73B--273J
				R015	247 0009 985	Chip Carbon 10k ohm 1/10W	RM 73B--103J
				R016	247 0009 985	Chip Carbon 10k ohm 1/10W	RM 73B--103J
				R017	247 0009 985	Chip Carbon 10k ohm 1/10W	RM 73B--103J
				R018	247 0008 960	Chip Carbon 3.3k ohm 1/10W	RM 73B--332J
				R019	247 0010 961	Chip Carbon 22k ohm 1/10W	RM 73B--223J
				R020	247 0011 944	Chip Carbon 47k ohm 1/10W	RM 73B--473J
				R022	247 0007 945	Chip Carbon 1k ohm 1/10W	RM 73B--102J
				R023	247 0011 960	Chip Carbon 56k ohm 1/10W	RM 73B--563J
				R024	247 0008 928	Chip Carbon 2.2k ohm 1/10W	RM 73B--222J
				R025	247 0012 927	Chip Carbon 100k ohm 1/10W	RM 73B--104J
				R027	247 0009 985	Chip Carbon 10k ohm 1/10W	RM 73B--103J
				R028	247 0008 960	Chip Carbon 3.3k ohm 1/10W	RM 73B--332J
				R029	247 0012 969	Chip Carbon 150k ohm 1/10W	RM 73B--154J

GENERAL SECTION-2

Ref. No.	Part No.	Part Name	Remarks	Ref. No.	Part No.	Part Name	Remarks
R030	247 0012 969	Chip Carbon 150k ohm 1/10W	RM73B--154J	C009	257 0004 961	Chip Ceramic 100pF/50V	CC73SL1H101J
R031	247 0008 960	Chip Carbon 3.3k ohm 1/10W	RM73B--332J	C010	254 4260 948	Electrolytic 1μF/50V	CE04W1H010M
R032	247 0008 960	Chip Carbon 3.3k ohm 1/10W	RM73B--332J	C011	257 0010 900	Chip Ceramic 0.01μF/50V	CK73B1H103K
R033	247 0012 969	Chip Carbon 150k ohm 1/10W	RM73B--154J	C012	254 4254 909	Electrolytic 10μF/16V	CE04W1C100M
R034	247 0012 969	Chip Carbon 150k ohm 1/10W	RM73B--154J	C013	257 0010 942	Chip Ceramic 0.022μF/50V	CK73B1H223K
R035	247 0008 960	Chip Carbon 3.3k ohm 1/10W	RM73B--332J	C014	257 0010 900	Chip Ceramic 0.01μF/50V	CK73B1H103K
R036	247 0008 960	Chip Carbon 3.3k ohm 1/10W	RM73B--332J	C015	254 4260 977	Electrolytic 4.7μF/50V	CE04W1H4R7M
R037	247 0007 945	Chip Carbon 1k ohm 1/10W	RM73B--102J	C016	254 4260 964	Electrolytic 3.3μF/50V	CE04W1H3R3M
R038	247 0007 945	Chip Carbon 1k ohm 1/10W	RM73B--102J	C017	257 0004 929	Chip Ceramic 68pF/50V	CC73SL1H680J
R041	247 0008 944	Chip Carbon 2.7k ohm 1/10W	RM73B--272J	C018	254 4254 909	Electrolytic 10μF/16V	CE04W1C100M
R045	247 0002 982	Chip Carbon 12 ohm 1/10W	RM73B--120J	C019	257 0010 942	Chip Ceramic 0.022μF/50V	CK73B1H223K
R046	247 0009 985	Chip Carbon 10k ohm 1/10W	RM73B--103J	C020	257 0010 900	Chip Ceramic 0.01μF/50V	CK73B1H103K
R047	247 0007 945	Chip Carbon 1k ohm 1/10W	RM73B--102J	C021	257 0010 926	Chip Ceramic 0.015μF/50V	CK73B1H153K
R048	247 0013 900	Chip Carbon 220k ohm 1/10W	RM73B--224J	C022	257 1013 993	Chip Ceramic 0.1μF/25V	CK73B1E104K
R049	247 0009 985	Chip Carbon 10k ohm 1/10W	RM73B--103J	C023	257 0002 963	Chip Ceramic 15pF/50V	CC73SL1H150J
R050	247 0010 961	Chip Carbon 22k ohm 1/10W	RM73B--223J	C024	254 3056 933	Electrolytic 3.3μF/50V	CE04D1H3R3MBP
R051	247 0009 985	Chip Carbon 10k ohm 1/10W	RM73B--103J	C025	254 3056 904	Electrolytic 0.47μF/50V	CE04D1HR47MBP
R052	247 0011 986	Chip Carbon 68k ohm 1/10W	RM73B--683J	C026	254 4254 909	Electrolytic 10μF/16V	CE04W1C100M
R053	247 0011 902	Chip Carbon 33k ohm 1/10W	RM73B--333J	C027	254 4260 948	Electrolytic 1μF/50V	CE04W1H010M
R054	247 0011 902	Chip Carbon 33k ohm 1/10W	RM73B--333J	C028	257 1011 982	Chip Ceramic 0.047μF/50V	CK73B1H473K
R055	247 0009 985	Chip Carbon 10k ohm 1/10W	RM73B--103J	C029	254 4254 938	Electrolytic 47μF/16V	CE04W1C470M
R056	247 0009 985	Chip Carbon 10k ohm 1/10W	RM73B--103J	C030	254 3056 917	Electrolytic 1μF/50V	CE04D1H010MBP
R057	247 0012 927	Chip Carbon 100k ohm 1/10W	RM73B--104J	C031	255 4201 984	Plastic Film 560pF/50V	CQ93P1H561J
R058	247 0012 927	Chip Carbon 100k ohm 1/10W	RM73B--104J	C032	257 0005 986	Chip Ceramic 330pF/50V	CC73SL1H331J
R059	247 0012 927	Chip Carbon 100k ohm 1/10W	RM73B--104J	C033	257 0005 986	Chip Ceramic 330pF/50V	CC73SL1H331J
R060	247 0012 927	Chip Carbon 100k ohm 1/10W	RM73B--104J	C034	257 0005 986	Chip Ceramic 330pF/50V	CC73SL1H331J
R061	247 0007 945	Chip Carbon 1k ohm 1/10W	RM73B--102J	C035	254 4254 909	Electrolytic 10μF/16V	CE04W1C100M
R062	247 0010 961	Chip Carbon 22k ohm 1/10W	RM73B--223J	C036	254 4254 909	Electrolytic 10μF/16V	CE04W1C100M
R063	247 0008 928	Chip Carbon 2.2k ohm 1/10W	RM73B--222J	C037	257 0002 989	Chip Ceramic 18pF/50V	CC73SL1H180J
R064	247 0005 989	Chip Carbon 220 ohm 1/10W	RM73B--221J	C038	257 0002 989	Chip Ceramic 18pF/50V	CC73SL1H180J
R065	247 0005 989	Chip Carbon 220 ohm 1/10W	RM73B--221J	C039	254 4254 909	Electrolytic 10μF/16V	CE04W1C100M
R066	247 0006 962	Chip Carbon 470 ohm 1/10W	RM73B--471J	C040	257 0010 900	Chip Ceramic 0.01μF/50V	CK73B1H103K
R067	247 0005 905	Chip Carbon 100 ohm 1/10W	RM73B--101J	C041	257 0004 929	Chip Ceramic 68pF/50V	CC73SL1H680J
R068	247 0007 945	Chip Carbon 1k ohm 1/10W	RM73B--102J	C042	257 0010 926	Chip Ceramic 0.015μF/50V	CK73B1H153K
R070	247 0011 944	Chip Carbon 47k ohm 1/10W	RM73B--473J	C043	257 0010 942	Chip Ceramic 0.022μF/50V	CK73B1H223K
R081	247 0005 947	Chip Carbon 150 ohm 1/10W	RM73B--151J	C044	257 0005 944	Chip Ceramic 220pF/50V	CC73SL1H221J
R101	247 0009 969	Chip Carbon 8.2k ohm 1/10W	RM73B--822J	C045	257 0005 915	Chip Ceramic 160pF/50V	CC73SL1H161J
R102	247 0009 969	Chip Carbon 8.2k ohm 1/10W	RM73B--822J	C046	255 4201 942	Plastic Film 390pF/50V	CQ93P1H391J
R103	247 0009 985	Chip Carbon 10k ohm 1/10W	RM73B--103J	C047	257 0002 963	Chip Ceramic 15pF/50V	CC73SL1H150J
R104	247 0009 985	Chip Carbon 10k ohm 1/10W	RM73B--103J	C048	257 0010 900	Chip Ceramic 0.01μF/50V	CK73B1H103K
R105	247 0012 927	Chip Carbon 100k ohm 1/10W	RM73B--104J	C049	257 0010 900	Chip Ceramic 0.01μF/50V	CK73B1H103K
R106	247 0012 927	Chip Carbon 100k ohm 1/10W	RM73B--104J	C050	254 3056 917	Electrolytic 1μF/50V	CE04D1H010MBP
R107	247 0006 962	Chip Carbon 470 ohm 1/10W	RM73B--471J	C051	257 0010 942	Chip Ceramic 0.022μF/50V	CK73B1H223K
R108	247 0006 962	Chip Carbon 470 ohm 1/10W	RM73B--471J	C053	254 4254 938	Electrolytic 47μF/16V	CE04W1C470M
R109	247 0012 969	Chip Carbon 100k ohm 1/10W	RM73B--104J	C060	257 0012 966	Chip Ceramic 0.01μF/50V	CK73F1H103Z
R110	247 0012 969	Chip Carbon 100k ohm 1/10W	RM73B--104J	C061	257 0012 966	Chip Ceramic 0.01μF/50V	CK73F1H103Z
R111	247 0011 944	Chip Carbon 47k ohm 1/10W	RM73B--473J	C071	257 0010 926	Chip Ceramic 0.015μF/50V	CK73B1H153K
R112	247 0011 944	Chip Carbon 47k ohm 1/10W	RM73B--473J	C072	254 4260 948	Electrolytic 1μF/50V	CE04W1H010M
R135	247 0010 958	Chip Carbon 20k ohm 1/10W	RM73B--203J	C099	257 0010 926	Chip Ceramic 0.015μF/50V	CK73B1H153K
R136	247 0010 958	Chip Carbon 20k ohm 1/10W	RM73B--203J	C101	254 4256 936	Electrolytic 47μF/25V	CE04W1E470M
R137	247 0005 905	Chip Carbon 100 ohm 1/10W	RM73B--101J	C102	254 4256 936	Electrolytic 47μF/25V	CE04W1E470M
R138	247 0005 905	Chip Carbon 100 ohm 1/10W	RM73B--101J	C103	254 4254 912	Electrolytic 22μF/16V	CE04W1C220M
				C104	254 4254 912	Electrolytic 22μF/16V	CE04W1C220M
				C105	257 0006 927	Chip Ceramic 470pF/50V	CC73SL1H471J
				C106	257 0006 927	Chip Ceramic 470pF/50V	CC73SL1H471J
				C107	257 1011 966	Chip Ceramic 0.033μF/50V	CK73B1H333K
				C108	257 1011 966	Chip Ceramic 0.033μF/50V	CK73B1H333K
				C109	254 4260 935	Electrolytic 0.47μF/50V	CE04W1H47M
				C110	254 4260 935	Electrolytic 0.47μF/50V	CE04W1H47M
				C111	257 0006 969	Chip Ceramic 680pF/50V	CC73SL1H681J
				C112	257 0006 969	Chip Ceramic 680pF/50V	CC73SL1H681J
				C113	257 0010 913	Chip Ceramic 0.012μF/50V	CK73B1H123K
				C114	257 0010 913	Chip Ceramic 0.012μF/50V	CK73B1H123K
				C115	257 0009 937	Chip Ceramic 2700pF/50V	CK73B1H272K
				C116	257 0009 937	Chip Ceramic 2700pF/50V	CK73B1H272K
VR001	211 6087 915	Semi Fixed VR. 22k ohm	V06PB223				
CAPACITORS GROUP							
C001	257 0010 942	Chip Ceramic 0.022μF/50V	CK73B1H223K				
C002	254 4254 909	Electrolytic 10μF/16V	CE04W1C100M				
C003	257 0010 900	Chip Ceramic 0.01μF/50V	CK73B1H103K				
C004	257 0010 900	Chip Ceramic 0.01μF/50V	CK73B1H103K				
C005	257 0010 942	Chip Ceramic 0.022μF/50V	CK73B1H223K				
C006	257 0010 942	Chip Ceramic 0.022μF/50V	CK73B1H223K				
C007	257 0010 942	Chip Ceramic 0.022μF/50V	CK73B1H223K				
C008	254 4260 964	Electrolytic 3.3μF/50V	CE04W1H3R3M				

GENERAL SECTION-2

KU-9258B-3,4,5 CD UNIT PARTS LIST

Ref. No.	Part No.	Part Name	Remarks	Ref. No.	Part No.	Part Name	Remarks
C117	254 4260 906	Electrolytic 0.1µF/50V	CE04W1H0R1M	SEMICONDUCTORS GROUP			
C118	254 4260 906	Electrolytic 0.1µF/50V	CE04W1H0R1M	IC201	262 1471 003	IC M50959-359SP	
C119	257 0005 986	Chip Ceramic 330pF/50V	CC73SL1H331J	IC301	262 1397 909	IC SM5840CS-L1	
C120	257 0005 986	Chip Ceramic 330pF/50V	CC73SL1H331J	IC302	262 1419 900	IC LC78820M	
C121	257 0010 900	Chip Ceramic 0.01µF/50V	CK73B1H103K	IC303	263 0615 902	IC BA15218F	
C122	257 0010 900	Chip Ceramic 0.01µF/50V	CK73B1H103K	IC304	268 0073 905	IC ICP-N15T	IC Protector
C123	257 1011 982	Chip Ceramic 0.047µF/50V	CK73B1H473K	IC305	268 0073 905	IC ICP-N15T	IC Protector
C124	257 1011 982	Chip Ceramic 0.047µF/50V	CK73B1H473K	IC306	263 0809 006	IC NJM78M05FA (S)	Regulator +5V
C125	254 4260 948	Electrolytic 1µF/50V	CE04W1H010M	IC401	263 0821 000	IC HA12158	
C126	254 4260 948	Electrolytic 1µF/50V	CE04W1H010M	IC402	263 0750 003	IC BA6290A	
C127	257 0009 966	Chip Ceramic 4700pF/50V	CK73B1H472K	IC403	263 0750 003	IC BA6290A	
C128	257 0009 966	Chip Ceramic 4700pF/50V	CK73B1H472K	IC404	263 0615 902	IC BA15218F	
C129	257 1013 993	Chip Ceramic 0.1µF/25V	CK73B1E104K	IC501	262 1572 300	IC µPD75116GF-G16-3BE	µ-com
C130	257 1013 993	Chip Ceramic 0.1µF/25V	CK73B1E104K	IC502	262 0678 001	IC MN1280-S	
C131	256 1034 092	Metalized 0.15µF/50V	CF93A1H154J	IC503	262 1514 009	IC CXD2500AQ	
C132	256 1034 092	Metalize 0.15µF/50V	CF93A1H154J	TR301	274 0160 907	Transister 2SD2144STPU	
C133	254 4260 948	Electrolytic 1µF/50V	CE04W1H010M	TR302	274 0160 907	Transister 2SD2144STPU	
C134	254 4260 948	Electrolytic 1µF/50V	CE04W1H010M	TR303	269 0082 902	Transister DTC114EK	Chip Built in R.
C135	254 4254 909	Electrolytic 10µF/16V	CE04W1C100M	TR304	269 0083 901	Transister DTA114EK	Chip Built in R.
C136	254 4254 909	Electrolytic 10µF/16V	CE04W1C100M	TR401	271 0102 908	Transister 2SA1015 (Y)	
C137	257 0004 961	Chip Ceramic 100pF/50V	CC73SL1H101J	TR402	274 0144 907	Transister :BC368	
C138	257 0004 961	Chip Ceramic 100pF/50V	CC73SL1H101J	TR403	272 0101 902	Transister :BC369	
C139	254 4254 909	Electrolytic 10µF/16V	CE04W1C100M	TR501	269 0054 901	Transister DTC144EK	Chip Built in R.
C140	254 4254 909	Electrolytic 10µF/16V	CE04W1C100M	TR502	269 0054 901	Transister DTC144EK	Chip Built in R.
C141	257 0014 935	Chip Ceramic 0.1µF/25V	CK73F1E104Z	TR504	269 0054 901	Transister DTC144EK	Chip Built in R.
C142	257 0014 935	Chip Ceramic 0.1µF/25V	CK73F1E104Z	TR505	269 0054 901	Transister DTC144EK	Chip Built in R.
C143	257 0012 966	Chip Ceramic 0.01µF/50V	CK73F1H103Z	TR507	269 0054 901	Transister DTC144EK	Chip Built in R.
C144	257 0012 966	Chip Ceramic 0.01µF/50V	CK73F1H103Z	TR509	269 0054 901	Transister DTC144EK	Chip Built in R.
C145	257 0004 961	Chip Ceramic 100pF/50V	CC73SL1H101J	TR511	269 0054 901	Transister DTC144EK	Chip Built in R.
C146	257 0004 961	Chip Ceramic 100pF/50V	CC73SL1H101J	TR513	269 0083 901	Transister DTA114EK	Chip Built in R.
TC001	213 0041 063	Trimmer Condenser		D351	276 0553 905	Diode 1SR35-200A	
TC002	213 0034 009	Trimmer Condenser (CTZ-51C)		D352	276 0553 905	Diode 1SR35-200A	
OTHER GROUP				D353	276 0553 905	Diode 1SR35-200A	
CF001,002	261 0064 007	(P.W.Board) FM C.Filter	SFT10.7MS2	D354	276 0553 905	Diode 1SR35-200A	
CF003	261 0046 009	AM C.Filter	SFZ450A	D355	276 0553 905	Diode 1SR35-200A	
CF004	261 0101 009	:AM C.Filter	BFU450C4N	D356	276 0553 905	Diode 1SR35-200A	
CF005	261 0103 007	:Ceramic Vibrator	CSB456F11	D357	276 0553 905	Diode 1SR35-200A	
LP001	232 9002 004	MPX Filter (ABW-07)		D358	276 0553 905	Diode 1SR35-200A	
LP002	232 0152 005	Ant Birdle Filter		D359	276 0553 905	Diode 1SR35-200A	
T001	231 2905 008	FM IF Det (A)		D502	276 0462 915	Zener Diode HZS6B-2	6V
T002	231 2906 007	FM IF Det (B)		D503	276 0462 915	Zener Diode HZS6B-2	6V
T003	231 3903 009	AM IFT		D504	276 0462 915	Zener Diode HZS6B-2	6V
T012	231 0923 008	MW Ant. Trans		D505	276 0462 915	Zener Diode HZS6B-2	6V
T014	231 1130 007	MW OSC Coil		D506	276 0462 915	Zener Diode HZS6B-2	6V
T011	231 1133 004	LW Ant. Trans		D507	276 0462 915	Zener Diode HZS6B-2	6V
T013	231 1135 002	LW OSC Coil		D601	276 0462 915	Zener Diode HZS6B-2	6V
X001	399 0075 003	Crystal Vibrator (7.2MHz)		D602	276 0462 915	Zener Diode HZS6B-2	6V
TE001	205 0603 002	3P Ant. Terminal (DIN)		D603	276 0462 915	Zener Diode HZS6B-2	6V
	414 9123 103	Earth Plate		D604	276 0462 915	Zener Diode HZS6B-2	6V
	001 9032 030	Copper Wire (L=20)		D605	276 0432 903	Diode 1SS270A	
	001 9032 0314	Copper Wire (L=35)		D606	276 0432 903	Diode 1SS270A	
CN5A,5B	205 0536 072	5P Conn. Socket		D607	276 0432 903	Diode 1SS270A	
CN8A	205 0536 001	8P Conn. Socket		D608	276 0432 903	Diode 1SS270A	
CN10B	205 0536 056	10P Conn. Socket		D612	393 9509 006	LED LN38GPPN	Green
CN12A	205 0536 027	12P Conn. Socket		RESISTORS GROUP (Not included Carbon Film ±5% 1/4W Type. Refer to the Schematic Diagram for those Parts.)			
TP001	205 0343 045	4P Conn. Base (KR-PH)		R301	247 0006 962	Chip Carbon 470 ohm 1/10W	RM 73B--471J
CN001	204 0398 000	6P PH Conn. Cord B-IN		R302	247 0006 962	Chip Carbon 470 ohm 1/10W	RM 73B--471J
				R303	247 0006 962	Chip Carbon 470 ohm 1/10W	RM 73B--471J
				R304	247 0006 962	Chip Carbon 470 ohm 1/10W	RM 73B--471J
				R305	247 0007 945	Chip Carbon 1k ohm 1/10W	RM 73B--102J
				R306	247 0007 945	Chip Carbon 1k ohm 1/10W	RM 73B--102J
				R307	247 0007 945	Chip Carbon 1k ohm 1/10W	RM 73B--102J
				R312	247 0018 905	Chip Carbon 0 ohm 1/10W	RM 73B--OR0K

GENERAL SECTION-2

Ref. No.	Part No.	Part Name	Remarks	Ref. No.	Part No.	Part Name	Remarks
R315	247 0010 990	Chip Carbon 30k ohm 1/10W	RM73B--303J	R511	247 0009 985	Chip Carbon 10k ohm 1/10W	RM73B--103J
R316	247 0010 990	Chip Carbon 30k ohm 1/10W	RM73B--303J	R512	247 0009 985	Chip Carbon 10k ohm 1/10W	RM73B--103J
R317	247 0007 903	Chip Carbon 680 ohm 1/10W	RM73B--681J	R514	247 0009 985	Chip Carbon 10k ohm 1/10W	RM73B--103J
R318	247 0007 903	Chip Carbon 680 ohm 1/10W	RM73B--681J	R515	247 0009 985	Chip Carbon 10k ohm 1/10W	RM73B--103J
R319	247 0009 901	Chip Carbon 4.7k ohm 1/10W	RM73B--472J	R516	247 0005 905	Chip Carbon 100 ohm 1/10W	RM73B--101J
R320	247 0009 901	Chip Carbon 4.7k ohm 1/10W	RM73B--472J	R517	247 0005 905	Chip Carbon 100 ohm 1/10W	RM73B--101J
R321	247 0005 905	Chip Carbon 100 ohm 1/10W	RM73B--101J	R518	247 0009 985	Chip Carbon 10k ohm 1/10W	RM73B--103J
R322	247 0005 905	Chip Carbon 100 ohm 1/10W	RM73B--101J	R521	247 0009 985	Chip Carbon 10k ohm 1/10W	RM73B--103J
R339	247 0012 998	Chip Carbon 200k ohm 1/10W	RM73B--204J	R522	247 0009 985	Chip Carbon 10k ohm 1/10W	RM73B--103J
R401	247 0003 949	Chip Carbon 22 ohm 1/10W	RM73B--220J	R524	247 0009 985	Chip Carbon 10k ohm 1/10W	RM73B--103J
R402	247 0005 976	Chip Carbon 200 ohm 1/10W	RM73B--201J	R527	247 0009 985	Chip Carbon 10k ohm 1/10W	RM73B--103J
R403	247 0008 902	Chip Carbon 1.8k ohm 1/10W	RM73B--182J	R528	247 0009 985	Chip Carbon 10k ohm 1/10W	RM73B--103J
R404	247 0009 969	Chip Carbon 8.2k ohm 1/10W	RM73B--822J	R530	247 0011 944	Chip Carbon 47k ohm 1/10W	RM73B--473J
R405	247 0010 903	Chip Carbon 12k ohm 1/10W	RM73B--123J	R531	247 0014 967	Chip Carbon 1M ohm 1/10W	RM73B--105J
R406	247 0009 985	Chip Carbon 10k ohm 1/10W	RM73B--103J	R533	247 0011 944	Chip Carbon 47k ohm 1/10W	RM73B--473J
R407	247 0009 985	Chip Carbon 10k ohm 1/10W	RM73B--103J	R534	247 0011 944	Chip Carbon 47k ohm 1/10W	RM73B--473J
R408	245 2370 946	Metal Film 33k ohm 1/4W	RN14K2E333F (5)	R601	247 0011 944	Chip Carbon 47k ohm 1/10W	RM73B--473J
R409	245 2370 904	Metal Film 22k ohm 1/4W	RN14K2E223F (5)	R602	247 0011 944	Chip Carbon 47k ohm 1/10W	RM73B--473J
R410	245 2370 946	Metal Film 33k ohm 1/4W	RN14K2E333F (5)	R603	247 0011 944	Chip Carbon 47k ohm 1/10W	RM73B--473J
R411	247 0012 901	Chip Carbon 82k ohm 1/10W	RM73B--823J	R604	247 0011 944	Chip Carbon 47k ohm 1/10W	RM73B--473J
R412	247 0010 903	Chip Carbon 12k ohm 1/10W	RM73B--123J	R605	247 0011 944	Chip Carbon 47k ohm 1/10W	RM73B--473J
R413	247 0011 902	Chip Carbon 33k ohm 1/10W	RM73B--333J	R606	247 0011 944	Chip Carbon 47k ohm 1/10W	RM73B--473J
R414	247 0010 961	Chip Carbon 22k ohm 1/10W	RM73B--223J	R607	247 0011 944	Chip Carbon 47k ohm 1/10W	RM73B--473J
R415	247 0011 902	Chip Carbon 33k ohm 1/10W	RM73B--333J	R608	247 0011 944	Chip Carbon 47k ohm 1/10W	RM73B--473J
R416	247 0010 961	Chip Carbon 22k ohm 1/10W	RM73B--223J	R609	247 0005 992	Chip Carbon 240 ohm 1/10W	RM73B--241J
R419	245 2369 902	Metal Film 8.2k ohm 1/4W	RN14K2E822F (5)	VR401	211 6087 931	Semi Fixed VR 4.7k ohm	V06PB472
R420	247 0010 961	Chip Carbon 22k ohm 1/10W	RM73B--223J	VR402	211 6087 928	Semi Fixed VR 100k ohm	V06PB472
R421	247 0008 960	Chip Carbon 3.3k ohm 1/10W	RM73B--332J	CAPACITORS GROUP			
R422	247 0005 905	Chip Carbon 100 ohm 1/10W	RM73B--101J	C300	257 0011 996	Chip Ceramic 0.1µF/25V	CK73B1E1 04K
R423	247 0007 945	Chip Carbon 1k ohm 1/10W	RM73B--102J	C301	254 4252 930	Electrolytic 100µF/10V	CE04W1A1 101M
R424	247 0004 922	Chip Carbon 470 ohm 1/10W	RM73B--470J	C302	254 4252 930	Electrolytic 100µF/10V	CE04W1A1 101M
R425	247 0011 902	Chip Carbon 33k ohm 1/10W	RM73B--333J	C303	257 0010 900	Chip Ceramic 0.01µF/50V	CK73B1H1 103K
R426	247 0011 902	Chip Carbon 33k ohm 1/10W	RM73B--333J	C304	257 0005 973	Chip Ceramic 300pF/50V	CC73SL1H 301J
R427	247 0011 902	Chip Carbon 33k ohm 1/10W	RM73B--333J	C305	257 0010 900	Chip Ceramic 0.01µF/50V	CK73B1H1 103K
R428	247 0009 972	Chip Carbon 9.1k ohm 1/10W	RM73B--912J	C307	254 4254 938	Electrolytic 47µF/16V	CE04W1C1 470M
R429	247 0008 931	Chip Carbon 2.4k ohm 1/10W	RM73B--242J	C308	254 4254 938	Electrolytic 47µF/16V	CE04W1C1 470M
R430	247 0008 931	Chip Carbon 2.4k ohm 1/10W	RM73B--242J	C311	254 6172 005	Electrolytic 100µF/16V	CE04W1C1 101M (RA2)
R431	247 0005 905	Chip Carbon 100 ohm 1/10W	RM73B--101J	C312	254 6172 005	Electrolytic 100µF/16V	CE04W1C1 101M (RA2)
R432	247 0009 985	Chip Carbon 10k ohm 1/10W	RM73B--103J	C313	257 0010 900	Chip Ceramic 0.01µF/50V	CK73B1H1 03K
R433	247 0009 985	Chip Carbon 10k ohm 1/10W	RM73B--103J	C315	257 0004 961	Chip Ceramic 100pF/50V	CC73SL1H 101J
R434	247 0009 943	Chip Carbon 6.8k ohm 1/10W	RM73B--682J	C316	257 0004 961	Chip Ceramic 100pF/50V	CC73SL1H 101J
R435	247 0009 956	Chip Carbon 7.5k ohm 1/10W	RM73B--752J	C320	257 0012 966	Chip Ceramic 0.01µF/50V	CK73F1H1 03Z
R436	247 0010 961	Chip Carbon 22k ohm 1/10W	RM73B--223J	C321	253 1146 907	Ceramic 0.01µF/50V	CK45F1H1 03Z
R437	247 0009 985	Chip Carbon 10k ohm 1/10W	RM73B--103J	C322	253 1024 003	Ceramic 0.01µF/50V	CK45F1H1 03Z
R438	247 0009 985	Chip Carbon 10k ohm 1/10W	RM73B--103J	C350	257 0010 900	Chip Ceramic 0.01µF/50V	CK73B1H1 03K
R439	247 0009 985	Chip Carbon 10k ohm 1/10W	RM73B--103J	C351	257 0010 900	Chip Ceramic 0.01µF/50V	CK73B1H1 03K
R440	247 0009 985	Chip Carbon 10k ohm 1/10W	RM73B--103J	C352	254 4256 949	Electrolytic 100µF/25V	CE04W1E1 01M
R441	247 0011 944	Chip Carbon 47k ohm 1/10W	RM73B--473J	C353	254 4256 949	Electrolytic 100µF/25V	CE04W1E1 01M
R442	247 0009 956	Chip Carbon 7.5k ohm 1/10W	RM73B--752J	C354	257 0010 900	Chip Ceramic 0.01µF/50V	CK73B1H1 03K
R443	247 0009 985	Chip Carbon 10k ohm 1/10W	RM73B--103J	C356	254 4254 941	Electrolytic 100µF/16V	CE04W1C1 01M
R444	247 0008 931	Chip Carbon 2.4k ohm 1/10W	RM73B--242J	C401	254 4254 909	Electrolytic 10µF/16V	CE04W1C1 00M
R445	247 0011 944	Chip Carbon 47k ohm 1/10W	RM73B--473J	C402	254 4254 909	Electrolytic 10µF/16V	CE04W1C1 00M
R446	245 2370 946	Metal Film 33k ohm 1/4W	RN14K2E333F (5)	C403	254 4250 929	Electrolytic 100µF/6.3V	CE04W0J1 01M
R450	247 0011 902	Chip Carbon 33k ohm 1/10W	RM73B--333J	C404	257 0004 961	Chip Ceramic 100pF/50V	CC73SL1H 101J
R460	247 0010 987	Chip Carbon 27k ohm 1/10W	RM73B--273J	C405	254 4254 909	Electrolytic 10µF/16V	CE04W1C1 00M
R461	247 0011 902	Chip Carbon 33k ohm 1/10W	RM73B--333J	C406	257 1010 938	Chip Ceramic 2700pF/50V	CK73B1H2 72K
R501	247 0009 985	Chip Carbon 10k ohm 1/10W	RM73B--103J	C407	257 1011 966	Chip Ceramic 0.033µF/50V	CK73B1H3 33K
R502	247 0008 928	Chip Carbon 2.2k ohm 1/10W	RM73B--222J	C408	257 0009 924	Chip Ceramic 2200pF/50V	CK73B1H2 22K
R503	247 0008 928	Chip Carbon 2.2k ohm 1/10W	RM73B--222J	C409	254 4260 935	Electrolytic 0.47µF/50V	CE04W1H3 47M
R504	247 0009 985	Chip Carbon 10k ohm 1/10W	RM73B--103J	C410	257 0010 900	Chip Ceramic 0.01µF/50V	CK73B1H1 03K
R505	247 0009 985	Chip Carbon 10k ohm 1/10W	RM73B--103J	C411	254 4254 909	Electrolytic 10µF/16V	CE04W1C1 00M
R506	247 0009 985	Chip Carbon 10k ohm 1/10W	RM73B--103J	C412	254 4260 935	Electrolytic 0.47µF/50V	CE04W1H3 47M
R508	247 0009 943	Chip Carbon 6.8k ohm 1/10W	RM73B--682J	C413	257 1011 995	Chip Ceramic 0.056µF/50V	CK73B1H5 56K
R509	247 0008 960	Chip Carbon 3.3k ohm 1/10W	RM73B--332J	C414	257 0010 955	Chip Ceramic 0.027µF/50V	CK73B1H2 27K
R510	247 0009 985	Chip Carbon 10k ohm 1/10W	RM73B--103J				

GENERAL SECTION-2

KU-9260B AMP UNIT PARTS LIST

Ref. No.	Part No.	Part Name	Remarks	Ref. No.	Part No.	Part Name	Remarks
C415	256 1034 995	Metalized 0.15µF/50V	CF93A1H154J	SEMICONDUCTORS GROUP			
C416	257 0006 901	Chip Ceramic 390pF/50V	CC73SL1H391J	IC101	263 0646 007	IC M5230L	
C417	254 4254 912	Electrolytic 22µF/16V	CE04W1C220M	IC102	263 0793 002	IC NJM78M06FA(S)	Regulator +6V
C418	254 4260 919	Electrolytic 0.22µF/50V	CE04W1HR22M	IC103	263 0809 006	IC NJM78M05FA(S)	Regulator +5V
C419	257 0008 983	Chip Ceramic 1000pF/50V	CK73B1H102K	IC201	262 1471 003	IC M50959-359SP	
C420	254 4250 929	Electrolytic 100µF/6.3V	CE04W0J101M	IC301	262 1277 008	IC LC7821	
C421	254 4254 909	Electrolytic 10µF/16V	CE04W1C100M	IC302	263 0611 003	IC :NE4558N	
C422	257 0009 979	Chip Ceramic 5600pF/50V	CK73B1H562K	IC307	262 1277 008	IC LC7821	
C423	254 4260 948	Electrolytic 1µF/50V	CE04W1H010M	IC309	265 0073 003	IC STK4152II	
C424	254 4260 919	Electrolytic 0.22µF/50V	CE04W1HR22M	IC501	262 1571 204	IC HD404719A16FS	µ-com.
C425	257 0010 900	Chip Ceramic 0.01µF/50V	CK73B1H103K	IC601	263 0611 003	IC :NE4558N	
C426	254 4252 927	Electrolytic 47µF/10V	CE04W1A470M	IC801	263 0476 002	IC LB1639	
C427	257 0010 926	Chip Ceramic 0.015µF/50V	CK73B1H153K	TR101	269 0020 906	Transister DTC114E	Built in Resistor
C430	257 0008 983	Chip Ceramic 1000pF/50V	CK73B1H102K	TR102	269 0093 904	Transister DTA144E	Built in Resistor
C431	254 4260 964	Electrolytic 3.3µF/50V	CE04W1H3R3M	TR103	269 0093 904	Transister DTA144E	Built in Resistor
C432	257 0010 942	Chip Ceramic 0.022µF/50V	CK73B1H223K	TR104	269 0020 906	Transister DTC114E	Built in Resistor
C433	257 0010 900	Chip Ceramic 0.01µF/50V	CK73B1H103K	TR105	269 0020 906	Transister DTC114E	Built in Resistor
C450	257 0008 983	Chip Ceramic 1000pF/50V	CK73B1H102K	TR107	269 0020 906	Transister DTC114E	Built in Resistor
C460	257 0012 966	Chip Ceramic 0.01µF/50V	CK73F1H103Z	TR108	273 0388 906	Transister 2SC1740S(E)	
C461	257 0012 966	Chip Ceramic 0.01µF/50V	CK73F1H103Z	TR109	273 0338 008	Transister 2SC3851 (F)/(G)	
C462	253 1146 907	Ceramic 0.01µF/50V	CK45F1H103Z	TR110	271 0206 008	Transister 2SA1488 (F)/(G)	
C501	254 4250 929	Electrolytic 100µF/6.3V	CE04W0J101M	TR112	269 0020 906	Transister DTC114E	Built in Resistor
C502	257 0011 996	Chip Ceramic 0.1µF/25V	CK73B1E104K	TR113	273 0253 918	Transister 2SC2878 (A/B)	
C503	254 4260 948	Electrolytic 1µF/50V	CE04W1H010M	TR114	273 0388 906	Transister 2SC1740S(E)	
C504	257 1011 982	Chip Ceramic 0.047µF/50V	CK73B1H473K	TR115	272 0053 908	Transister 2AB647A (D)	
C505	257 0009 908	Chip Ceramic 1500pF/50V	CK73B1H152K	TR116	272 0107 906	Transister 2SB1328 (F)	
C506	257 0011 996	Chip Ceramic 0.1µF/25V	CK73B1E104K	TR303	273 0388 906	Transister 2SC1740S(E)	
C507	254 4250 932	Electrolytic 220µF/6.3V	CE04W0J221M	TR304	273 0388 906	Transister 2SC1740S(E)	
C508	257 0011 996	Chip Ceramic 0.1µF/25V	CK73B1E104K	TR305	273 0388 906	Transister 2SC1740S(E)	
C509	257 0001 977	Chip Ceramic 5pF/50V	CC73SL1H5R0C	TR307	273 0388 906	Transister 2SC1740S(E)	
C510	257 0001 977	Chip Ceramic 5pF/50V	CC73SL1H5R0C	TR310	273 0388 906	Transister 2SC1740S(E)	
C511	257 0006 927	Chip Ceramic 470pF/50V	CC73SL1H471J	TR312	273 0388 906	Transister 2SC1740S(E)	
C512	257 0006 927	Chip Ceramic 470pF/50V	CC73SL1H471J	TR314	273 0388 906	Transister 2SC1740S(E)	
C518	257 0012 966	Chip Ceramic 0.01µF/50V	CK73F1H103Z	TR318	269 0020 906	Transister DTC114E	Built in Resistor
C520	253 1146 907	Ceramic 0.01µF/50V	CK45F1H103Z	TR319	269 0093 904	Transister DTA144E	Built in Resistor
C521	253 1146 907	Ceramic 0.01µF/50V	CK45F1H103Z	TR320	269 0020 906	Transister DTC114E	Built in Resistor
C522	257 0012 966	Chip Ceramic 0.01µF/50V	CK73F1H103Z	TR501	273 0388 906	Transister 2SC1740S(E)	
C523	257 0012 966	Chip Ceramic 0.01µF/50V	CK73F1H103Z	TR601	269 0107 900	Transister RN1241 (AB)	Built in Resistor
C530	257 0012 966	Chip Ceramic 0.01µF/50V	CK73F1H103Z	TR602	269 0107 900	Transister RN1241 (AB)	Built in Resistor
OTHER GROUP							
		(P.W.Board)					(1)
	212 5604 910	Tact Switch					9
X501	399 9018 003	Ceramic Vibrator	CST 4.00 MGW	D102	276 0553 905	Diode 1SR35-200A	
X502	399 0115 002	Ceramic Vibrator	CSA16.93MX	D103	276 0553 905	Diode 1SR35-200A	
				D104	276 0432 903	Diode 1SS270A	
CC301	205 0185 038	3P Wire Holder		D106	276 0432 903	Diode 1SS270A	
CB404	205 0343 058	5P Conn. Base (KR-PH)		D108	276 0432 903	Diode 1SS270A	
CB403	205 0343 061	6P Conn. Base (KR-PH)		D110	276 0553 905	Diode 1SR35-200A	
CB401	205 0343 074	7P Conn. Base (KR-PH)		D111	276 0553 905	Diode 1SR35-200A	
CB402	205 0343 087	8P Conn. Base (KR-PH)		D112	276 0553 905	Diode 1SR35-200A	
TP404,405	205 0133 022	2P NH Conn. Base		D113	276 0553 905	Diode 1SR35-200A	
CB301	205 0233 032	3P NH Conn. Base		D114	276 0553 905	Diode 1SR35-200A	
CB502A	205 0726 099	10P Bottom Socket		D115	276 0553 905	Diode 1SR35-200A	
CB502B	205 0727 098	10P Bottom Plug		D116	276 0553 905	Diode 1SR35-200A	
CB503	205 0741 003	13P Trap Conn. Base		D117	276 0553 905	Diode 1SR35-200A	
CC301	203 4493 089	3P EH Conn. Cord	L=100	D301	276 0503 900	Diode 1SS198	
				D302	276 0503 900	Diode 1SS198	
				D500	276 0531 901	Diode 1SS254	
				D505	276 0553 905	Diode 1SR35-200A	
				D506	276 0432 903	Diode 1SS270A	
				D507	276 0531 901	Diode 1SS254	
				D508	276 0531 901	Diode 1SS254	
				D509	276 0531 901	Diode 1SS254	
				D510	276 0531 901	Diode 1SS254	
				D511	276 0531 901	Diode 1SS254	

GENERAL SECTION-2

Ref. No.	Part No.	Part Name	Remarks	Ref. No.	Part No.	Part Name	Remarks
D512	276 0531 901	Diode 1SS254		C120	253 1181 904	Ceramic 0.01 μF/50V	CK45F1H103Z
D513	276 0531 901	Diode 1SS254		C121	253 1181 904	Ceramic 0.01 μF/50V	CK45F1H103Z
D514	276 0531 901	Diode 1SS254		C122	254 4260 948	Electrolytic 1 μF/50V	CE04W1H010M
D517	276 0531 901	Diode 1SS254		C123	254 4264 012	Electrolytic 47 μF/100V	CE04W2A470M
D523	276 0531 901	Diode 1SS254		C124	254 3056 975	Electrolytic 33 μF/50V	CE04D1H330MBP (Bipole)
D524	276 0531 901	Diode 1SS254		C125	253 9031 920	BC Ceramic 0.1 μF/25V	CK45-1E104K
D530	276 0432 903	Diode 1SS270A		C126	254 4257 702	Electrolytic 3300 μF/25V	CE04W1E332MC
D531	276 0432 903	Diode 1SS270A		C127	254 4256 790	Electrolytic 2200 μF/25V	CE04W1E222MC
ZD101	276 0479 908	Zener Diode HZS20-1	20V	C128	254 4254 938	Electrolytic 47 μF/16V	CE04W1C470M
ZD102	276 0484 919	Zener Diode HZS33-2	33V	C129	254 4254 938	Electrolytic 47 μF/16V	CE04W1C470M
ZD105	276 0474 903	Zener Diode HZS12B-1	12V	C130	254 4256 907	Electrolytic 10 μF/25V	CE04W1E100M
ZD107	276 0453 924	Zener Diode HZS3B-3	3V	C131	254 4256 907	Electrolytic 10 μF/25V	CE04W1E100M
ZD109	276 0463 914	Zener Diode HZS6C-2	6V	C132	254 4256 952	Electrolytic 220 μF/25V	CE04W1E221M
ZD301	276 0462 915	Zener Diode HZS6B-2	6V	C134	254 3058 708	Electrolytic 220 μF/16V	CE04D1C221MBPC (Bipole)
ZD303	276 0462 915	Zener Diode HZS6B-2	6V	C140	254 4260 948	Electrolytic 1 μF/50V	CE04W1H010M
ZD305	276 0462 915	Zener Diode HZS6B-2	6V	C307	253 4538 949	Ceramic 100pF/50V	CC45SL1H101J
ZD307	276 0462 915	Zener Diode HZS6B-2	6V	C308	253 4538 949	Ceramic 100pF/50V	CC45SL1H101J
ZD308	276 0462 915	Zener Diode HZS6B-2	6V	C309	253 4538 949	Ceramic 100pF/50V	CC45SL1H101J
ZD309	276 0462 915	Zener Diode HZS6B-2	6V	C310	253 4538 949	Ceramic 100pF/50V	CC45SL1H101J
ZD310	276 0455 919	Zener Diode HZS4A-2	4V	C311	253 4538 949	Ceramic 100pF/50V	CC45SL1H101J
ZD501	276 0452 925	Zener Diode HZS3A-3	3V	C312	253 4538 949	Ceramic 100pF/50V	CC45SL1H101J
ZD502	276 0462 915	Zener Diode HZS6B-2	6V	C313	253 1181 917	Ceramic 0.022 μF/50V	CK45F1H223Z
ZD503	276 0462 915	Zener Diode HZS6B-2	6V	C314	253 1181 917	Ceramic 0.022 μF/50V	CK45F1H223Z
ZD504	276 0462 915	Zener Diode HZS6B-2	6V	C315	253 4538 949	Ceramic 100pF/50V	CC45SL1H101J
ZD505	276 0462 915	Zener Diode HZS6B-2	6V	C316	253 4538 949	Ceramic 100pF/50V	CC45SL1H101J
RESISTORS GROUP (Not included Carbon Film ±5%, 1/4W Type. Refer to the Schematic Diagram for those Parts.)				C317	254 4254 909	Electrolytic 10 μF/16V	CE04W1C100M
ΔR114	244 2052 960	Metal Oxide 220 ohm 1W (NB)	RS14B3A221JNBS (S)	C318	254 4254 909	Electrolytic 10 μF/16V	CE04W1C100M
ΔR115	241 2387 908	Carbon Film 1 ohm 1/4W (NB)	RD14B2E010JNBS	C319	253 4538 949	Ceramic 100pF/50V	CC45SL1H101J
ΔR116	241 2387 908	Carbon Film 1 ohm 1/4W (NB)	RD14B2E010JNBS	C320	253 4538 949	Ceramic 100pF/50V	CC45SL1H101J
ΔR126	241 2377 947	Carbon Film 100 ohm 1/4W (NB)	RD14B2E101JNBS	C335	254 4260 964	Electrolytic 3.3 μF/50V	CE04W1H3R3M
ΔR129	241 2377 947	Carbon Film 100 ohm 1/4W (NB)	RD14B2E101JNBS	C336	254 4260 964	Electrolytic 3.3 μF/50V	CE04W1H3R3M
ΔR130	244 2043 937	Metal Oxide 10 ohm 1W (NB)	RS14B3A100JNBS (S)	C338	253 4538 949	Ceramic 100pF/50V	CC45SL1H101J
ΔR131	244 2043 937	Metal Oxide 10 ohm 1W (NB)	RS14B3A100JNBS (S)	C339	253 4538 949	Ceramic 100pF/50V	CC45SL1H101J
ΔR455	241 2377 947	Carbon Film 100 ohm 1/4W (NB)	RD14B2E101JNBS	C371	253 1181 917	Ceramic 0.022 μF/50V	CK45F1H223Z
ΔR456	241 2377 947	Carbon Film 100 ohm 1/4W (NB)	RD14B2E101JNBS	C372	253 1181 917	Ceramic 0.022 μF/50V	CK45F1H223Z
ΔR459	244 2051 987	Metal Oxide 4.7 ohm 1W (NB)	RS14B3A4R7JNBS (S)	C383	254 4254 909	Electrolytic 10 μF/16V	CE04W1C100M
ΔR460	244 2051 987	Metal Oxide 4.7 ohm 1W (NB)	RS14B3A4R7JNBS (S)	C384	254 4254 909	Electrolytic 10 μF/16V	CE04W1C100M
ΔR469	244 2043 982	Metal Oxide 0.22 ohm 1W (NB)	RS14B3AR22JNBS (S)	C385	254 4258 905	Electrolytic 4.7 μF/35V	CE04W1V4R7M
ΔR470	244 2043 982	Metal Oxide 0.22 ohm 1W (NB)	RS14B3AR22JNBS (S)	C386	254 4258 905	Electrolytic 4.7 μF/35V	CE04W1V4R7M
ΔR505	241 2375 907	Carbon Film 10 ohm 1/4W (NB)	RD14B2E100JNBS	C387	253 1180 905	Ceramic 680pF/50V	CK45B1H68 1K
VR801	211 0749 107	Variable VR 100k ohm	V1620V20FB104T	C388	253 1180 905	Ceramic 680pF/50V	CK45B1H68 1K
RA501	246 2080 006	Resistor Array 47k ohm×9	RK99==473JP9	C389	254 4261 921	Electrolytic 100 μF/50V	CE04W1H101M
RA502	246 2043 027	Resistor Array 47k ohm×10	RK99==473JP10	C390	254 4261 921	Electrolytic 100 μF/50V	CE04W1H101M
RA503	246 2081 018	Resistor Array 10k ohm×16	RK99==103JP16	C391	253 4536 941	Ceramic 15pF/50V	CC45SL1H1 50J
RA504	246 2081 018	Resistor Array 10k ohm×16	RK99==103JP16	C392	253 4536 941	Ceramic 15pF/50V	CC45SL1H1 50J
CAPACITORS GROUP				C393	254 4261 921	Electrolytic 100 μF/50V	CE04W1H101M
C101	253 1181 904	Ceramic 0.01 μF/50V	CK45F1H103Z	C394	254 4261 921	Electrolytic 100 μF/50V	CE04W1H101M
C102	254 4260 948	Electrolytic 1 μF/50V	CE04W1H010M	C395	254 4260 980	Electrolytic 10 μF/50V	CE04W1H100M
C103	254 4256 910	Electrolytic 22 μF/25V	CE04W1E220M	C399	256 1034 937	Metalized 0.047 μF/50V	CF93A1H473J
C104	254 4256 910	Electrolytic 22 μF/25V	CE04W1E220M	C400	256 1034 937	Metalized 0.047 μF/50V	CF93A1H473J
C106	254 4260 045	Electrolytic 1 μF/50V	CE04W1H010M	C403	254 4260 948	Electrolytic 1 μF/50V	CE04W1H010M
C108	253 1053 003	Ceramic 0.01 μF/500V	CK45E2H103P	C404	254 4260 948	Electrolytic 1 μF/50V	CE04W1H010M
C109	254 4260 980	Electrolytic 10 μF/50V	CE04W1H100M	C405	253 1179 961	Ceramic 330pF/50V	CK45B1H3 1K
C110	254 4260 980	Electrolytic 10 μF/50V	CE04W1H100M	C406	253 1179 961	Ceramic 330pF/50V	CK45B1H3 1K
C111	254 4424 700	Electrolytic 4700 μF/45V	CE04W==472MC	C505	253 1181 904	Ceramic 0.01 μF/50V	CK45F1H103Z
C112	254 4424 700	Electrolytic 4700 μF/45V	CE04W==472MC	C506	254 4250 068	Electrolytic 1000 μF/6.3V	CE04W0J0 2M
C113	254 4260 993	Electrolytic 22 μF/50V	CE04W1H220M	C508	254 4254 938	Electrolytic 47 μF/16V	CE04W1C47 0M
C114	253 9031 920	BC Ceramic 0.1 μF/25V	CK45-1E104K	C509	254 4254 938	Electrolytic 47 μF/16V	CE04W1C47 0M
C115	254 3058 708	Electrolytic 220 μF/16V	CE04D1C221MBPC (Bipole)	C571	254 4260 906	Electrolytic 0.1 μF/50V	CE04W1H3FR1M
C117	253 1181 904	Ceramic 0.01 μF/50V	CK45F1H103Z	C572	254 4260 906	Electrolytic 0.1 μF/50V	CE04W1H3FR1M
C118	253 1181 904	Ceramic 0.01 μF/50V	CK45F1H103Z	C573	254 4260 948	Electrolytic 1 μF/50V	CE04W1H31 0M
C119	254 4260 948	Electrolytic 1 μF/50V	CE04W1H010M	C574	254 4258 057	Electrolytic 100 μF/35V	CE04W1V0 1M
				C575	253 1179 987	Ceramic 470pF/50V	CK45B1H7 1K
				C576	253 1179 987	Ceramic 470pF/50V	CK45B1H7 1K
				C577	253 1179 987	Ceramic 470pF/50V	CK45B1H7 1K

GENERAL SECTION-2

Ref. No.	Part No.	Part Name	Remarks	Ref. No.	Part No.	Part Name	Remarks	Qty
C578	253 1180 921	Ceramic 1000pF/50V	CK45B1H102K	205 0452 017	Style Pin			1
C579	254 4260 977	Electrolytic 4.7μF/50V	CE04W1H4R7M	205 0343 032	3P Conn. Base (KR-PH)			1
C580	254 4258 060	Electrolytic 220μF/35V	CE04W1V221M	205 0343 058	5P Conn. Base (KR-PH)			2
C601	254 4193 905	Electrolytic 10μF/16V	CE04W1C100M (SRA)	204 2529 000	8P PH-SAN Conn. Cord			1
C602	254 4193 905	Electrolytic 10μF/16V	CE04W1C100M (SRA)	203 0419 067	1P SIN Conn. Assy			1
C603	253 4538 949	Ceramic 100pF/50V	CC45SL1H101J	203 0383 067	1P SIN Conn. Assy			1
C604	253 4538 949	Ceramic 100pF/50V	CC45SL1H101J	203 0385 023	1P SIN Conn. Assy			1
C605	253 1181 904	Ceramic 0.01μF/50V	CK45F1H103Z	204 0376 006	6P SAN-PH Conn. Cord			1
C606	253 1181 904	Ceramic 0.01μF/50V	CK45F1H103Z					
C607	254 4193 905	Electrolytic 10μF/16V	CE04W1C100M (SRA)					
C608	254 4254 909	Electrolytic 10μF/16V	CE04W1C100M					
C609	254 4254 909	Electrolytic 10μF/16V	CE04W1C100M					
C610	254 4254 909	Electrolytic 10μF/16V	CE04W1C100M					
C611	253 4538 949	Ceramic 100pF/50V	CC45SL1H101J					
C612	253 4538 949	Ceramic 100pF/50V	CC45SL1H101J					
C777	253 4538 949	Ceramic 100pF/50V	CC45SL1H101J					
C778	253 4538 949	Ceramic 100pF/50V	CC45SL1H101J					
C779	254 4260 948	Electrolytic 1μF/50V	CE04W1H010M					
C801	254 4252 930	Electrolytic 100μF/10V	CE04W1A101M					
C802	253 1181 904	Ceramic 0.01μF/50V	CK45F1H103Z					
C990	256 1049 702	Metalized 0.22μF/250V	CF93B2E224K					
C991	253 1005 006	Ceramic 1500pF/50V	CK45B1H152K					
C992	253 1005 006	Ceramic 1500pF/50V	CK45B1H152K					
C993	253 1063 006	Ceramic 5600pF/50V	CK45B1H562K					
C994	253 1063 006	Ceramic 5600pF/50V	CK45B1H562K					
C995	256 1044 008	Metalized 0.22μF/100V	CF93B2A224K (GU)					
C996	256 1044 008	Metalized 0.22μF/100V	CF93B2A224K (GU)					
OTHER GROUP								
		(P.W.Board)						(1)
	125 9002 007	UL Tube (L=10)	for C991,992					2
	125 9002 010	UL Tube (L=5)	for C993,994					4
	125 9006 075	UL Tube (L=20)	for D524					1
X501	399 9025 009	Ceramic Vibrator	CST4.50 MGW					1
FL501	393 4133 008	FLD (FIP19AM10)						1
	499 0150 008	Remocon Receiver	SBX1610-52					1
	461 0496 026	Spacer						1
	461 0415 007	Rubber Sheet	for C995,996					4
SW501~513	212 5604 910	Tact Switch						13
ΔF501	206 1015 029	Fuse 1A						1
ΔF502,493	206 1015 059	Fuse 1.5A						2
RL301	202 0040 909	Fuse Clip						6
L301,302	214 0154 005	Relay(VB24SMBU)						1
	235 0068 004	Inductor 1mH						2
	204 8266 008	4P Pin Jack (S-GND)						1
	204 8406 004	1P Pin Jack						1
	205 0592 029	4P Push Terminal						1
CB301	204 8284 022	15P System Socket						1
CB302	205 0730 056	13P System Socket (BU)						1
CN33A,33B	205 0736 005	33P FFC Base						2
	205 0606 025	2P Wrapping Terminal						1
CN5B,5C	205 0535 073	5P Conn. Base						2
	205 0739 057	15P Conn. Socket						1
CN10A,10B 10C,10D	205 0535 057	10P Conn. Base						4
	205 0739 060	16P Conn. Socket						1
CN5A	205 0233 058	5P EH Conn. Base						1
CN15A	205 0740 059	15P Conn. Base						1
CN16A	205 0740 062	16P Conn. Base						1
CN8A	205 0535 002	8P Conn. Base						1
CN12A	205 0535 028	12P Conn. Base						1
CN10A,10C	205 0536 056	10P Conn. Socket						2
	204 2285 027	10P DA-DA Conn. Cord						1
	203 0469 033	1P Contact Assy						1
	203 0469 046	1P Contact Assy						1
	203 0497 018	1P Contact Assy						1

1U-2410B P.W.B. UNIT (3) PARTS LIST

This unit is wholly used in the receiver section.

Ref. No.	Part No.	Part Name	Remarks
SEMICONDUCTORS GROUP			
IC109	263 0609 002	IC NJM2068DDC	
IC701	263 0743 007	IC NJM2082DD	
RESISTORS GROUP			
R120	241 2405 974	Carbon Film 1M ohm 1/4W	RD14B2E105J (5)
R121	241 2402 935	Carbon Film 39k ohm 1/4W	RD14B2E393J (5)
R122	241 2397 901	Carbon Film 220 ohm 1/4W	RD14B2E221J (5)
R123	241 2401 978	Carbon Film 22k ohm 1/4W	RD14B2E223J (5)
R124	241 2400 995	Carbon Film 10k ohm 1/4W	RD14B2E103J (5)
R125	241 2398 955	Carbon Film 1k ohm 1/4W	RD14B2E102J (5)
R126	241 2396 928	Carbon Film 100 ohm 1/4W	RD14B2E101J (5)
R128	241 2402 935	Carbon Film 39k ohm 1/4W	RD14B2E393J (5)
R202	241 2403 976	Carbon Film 150k ohm 1/4W	RD14B2E154J (5)
R203	241 2403 976	Carbon Film 150k ohm 1/4W	RD14B2E154J (5)
R204	241 2396 928	Carbon Film 100 ohm 1/4W	RD14B2E101J (5)
R205	241 2396 928	Carbon Film 100 ohm 1/4W	RD14B2E101J (5)
R220	241 2405 974	Carbon Film 1M ohm 1/4W	RD14B2E105J (5)
R220	241 2405 974	Carbon Film 1M ohm 1/4W	RD14B2E105J (5)
R220	241 2400 911	Carbon Film 4.7k ohm 1/4W	RD14B2E472J (5)
R221	241 2400 911	Carbon Film 4.7k ohm 1/4W	RD14B2E472J (5)
R221	241 2402 935	Carbon Film 39k ohm 1/4W	RD14B2E393J (5)
R222	241 2400 911	Carbon Film 4.7k ohm 1/4W	RD14B2E472J (5)
R222	241 2397 901	Carbon Film 220 ohm 1/4W	RD14B2E221J (5)
R223	241 2400 911	Carbon Film 4.7k ohm 1/4W	RD14B2E472J (5)
R223	241 2401 978	Carbon Film 22k ohm 1/4W	RD14B2E223J (5)
R224	241 2400 995	Carbon Film 10k ohm 1/4W	RD14B2E103J (5)
R224	241 2405 974	Carbon Film 1M ohm 1/4W	RD14B2E105J (5)
R225	241 2398 955	Carbon Film 1k ohm 1/4W	RD14B2E102J (5)
R225	241 2405 974	Carbon Film 1M ohm 1/4W	RD14B2E105J (5)
R226	241 2397 972	Carbon Film 470 ohm 1/4W	RD14B2E471J (5)
R226	241 2396 928	Carbon Film 100 ohm 1/4W	RD14B2E101J (5)
R227	241 2397 972	Carbon Film 470 ohm 1/4W	RD14B2E471J (5)
R228	241 2402 935	Carbon Film 39k ohm 1/4W	RD14B2E393J (5)
R701	241 2399 938	Carbon Film 2.2k ohm 1/4W	RD14B2E222J (5)
R702	241 2399 938	Carbon Film 2.2k ohm 1/4W	RD14B2E222J (5)
R705	241 2402 993	Carbon Film 68k ohm 1/4W	RD14B2E683J (5)
R706	241 2402 993	Carbon Film 68k ohm 1/4W	RD14B2E683J (5)
R709	241 2398 913	Carbon Film 680 ohm 1/4W	RD14B2E681J (5)
R710	241 2398 913	Carbon Film 680 ohm 1/4W	RD14B2E681J (5)
R711	241 2404 933	Carbon Film 270k ohm 1/4W	RD14B2E274J (5)
R712	241 2404 933	Carbon Film 270k ohm 1/4W	RD14B2E274J (5)
R713	241 2401 978	Carbon Film 22k ohm 1/4W	RD14B2E223J (5)
R714	241 2401 978	Carbon Film 22k ohm 1/4W	RD14B2E223J (5)
R715	241 2396 928	Carbon Film 100 ohm 1/4W	RD14B2E101J (5)
R716	241 2396 928	Carbon Film 100 ohm 1/4W	RD14B2E101J (5)
R717	241 2397 972	Carbon Film 470 ohm 1/4W	RD14B2E471J (5)
R718	241 2397 972	Carbon Film 470 ohm 1/4W	RD14B2E471J (5)
R719	241 2403 934	Carbon Film 100k ohm 1/4W	RD14B2E104J (5)
R720	241 2403 934	Carbon Film 100k ohm 1/4W	RD14B2E104J (5)
ΔR477	244 2055 941	Metal Oxide 330 ohm 1/4W	RS14B3A33J (NS)
ΔR478	244 2055 941	Metal Oxide 330 ohm 1/4W	RS14B3A33J (NS)
VR101	211 0766 009	Variable VR 50k ohm	V0920V15FB503
VR102	211 0766 009	Variable VR 50k ohm	V0920V15FB503
CAPACITORS GROUP			
C121	255 1203 901	Plastic Film 0.0018μF/50V	CQ93M1H182J
C122	255 1216 901	Plastic Film 0.022μF/50V	CQ93M1H223J
C123	255 1216 901	Plastic Film 0.022μF/50V	CQ93M1H223J
C124	254 4260 948	Electrolytic 1μF/50V	CE04W1H010M
C125	253 4448 903	Ceramic 330pF/50V	CC45SL1H331J
C126	253 4444 907	Ceramic 220pF/50V	CC45SL1H221J
C127	254 4254 909	Electrolytic 10μF/16V	CE04W1C100M
C200	253 4443 908	Ceramic 200pF/50V	CC45SL1H201J
C201	253 4443 908	Ceramic 200pF/50V	CC45SL1H201J
C214	253 4436 902	Ceramic 100pF/50V	CC45SL1H101J
C215	253 4436 902	Ceramic 100pF/50V	CC45SL1H101J
C216	253 4436 902	Ceramic 100pF/50V	CC45SL1H101J
C217	253 4436 902	Ceramic 100pF/50V	CC45SL1H101J
C221	255 1203 901	Plastic Film 0.0018μF/50V	CQ93M1H182J
C222	255 1216 901	Plastic Film 0.022μF/50V	CQ93M1H223J
C222	254 4260 948	Electrolytic 1μF/50V	CE04W1H010M
C223	255 1216 901	Plastic Film 0.022μF/50V	CQ93M1H223J
C223	253 1181 907	Ceramic 0.01μF/50V	CK45F1H103Z

Ref. No.	Part No.	Part Name	Remarks
C224	254 4260 948	Electrolytic 1μF/50V	CE04W1H010M
C225	253 4448 903	Ceramic 330pF/50V	CC45SL1H331J
C226	253 4444 907	Ceramic 220pF/50V	CC45SL1H221J
C227	254 4254 909	Electrolytic 10μF/16V	CE04W1C100M
C315	253 1146 907	Ceramic 0.01μF/50V	CK45F1H103Z
C316	253 1146 907	Ceramic 0.01μF/50V	CK45F1H103Z
C397	253 1181 917	Ceramic 0.022μF/50V	CK45F1H223Z
C398	253 1181 917	Ceramic 0.022μF/50V	CK45F1H223Z
C701	254 4260 948	Electrolytic 1μF/50V	CE04W1H010M
C702	253 1146 907	Ceramic 0.01μF/50V	CK45F1H103Z
C705	254 4254 909	Electrolytic 10μF/16V	CE04W1C100M
C706	254 4254 909	Electrolytic 10μF/16V	CE04W1C100M
C707	254 4250 929	Electrolytic 100μF/6.3V	CE04W0J101M
C708	254 4250 929	Electrolytic 100μF/6.3V	CE04W0J101M
C711	255 1213 904	Plastic Film 0.012μF/50V	CQ93M1H123J
C712	255 1213 904	Plastic Film 0.012μF/50V	CQ93M1H123J
C713	255 1206 908	Plastic Film 0.0033μF/50V	CQ93M1H332J
C714	255 1206 908	Plastic Film 0.0033μF/50V	CQ93M1H332J
C715	254 4254 909	Electrolytic 10μF/16V	CE04W1C100M
C716	254 4254 909	Electrolytic 10μF/16V	CE04W1C100M
OTHER GROUP			
		(P.W.Board)	(1)
L701,			

SPEAKER SECTION

EXPLODED VIEW

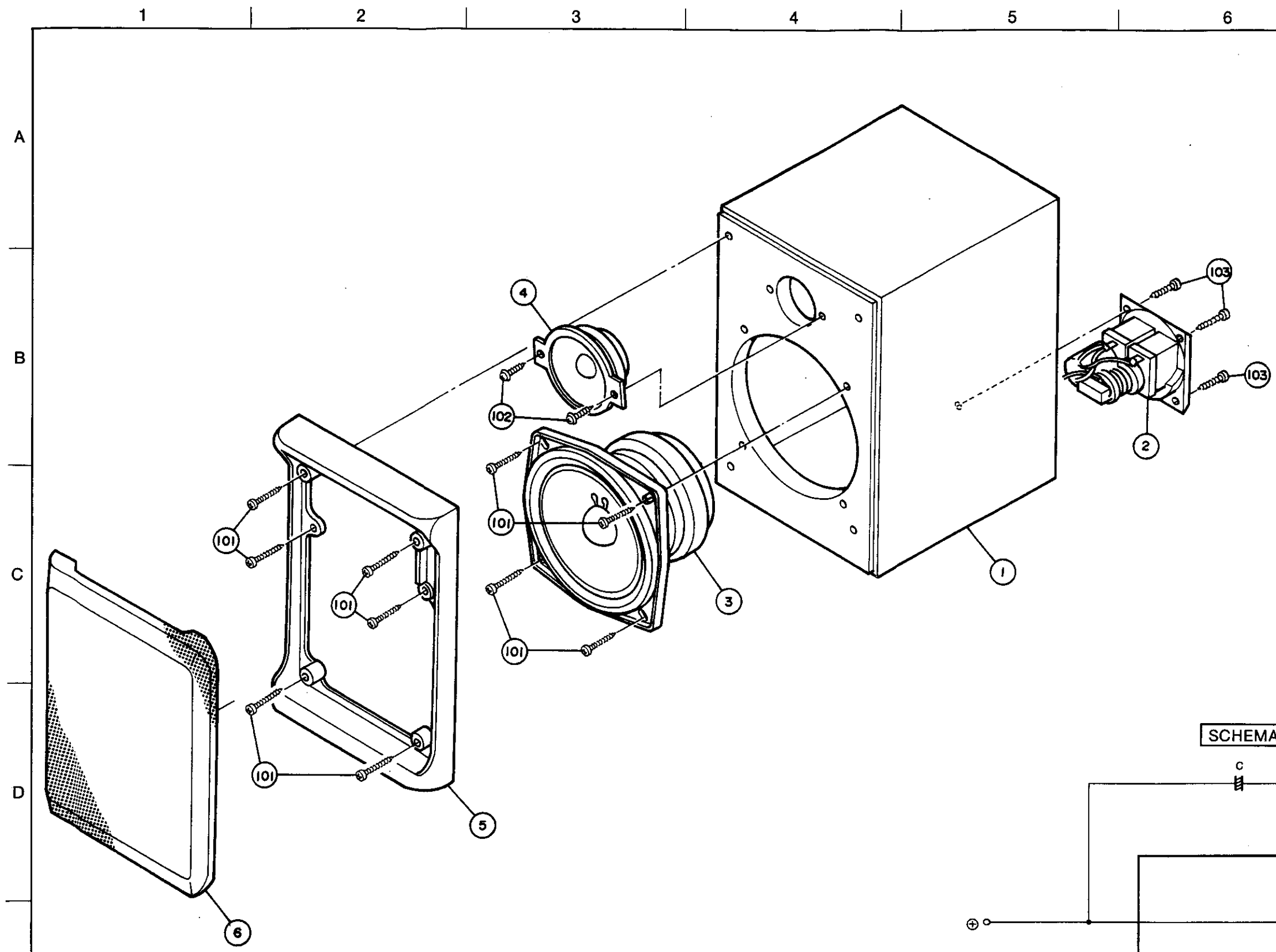

PARTS LIST OF USC-60 EXPLODED VIEW

Ref. No.	Part No.	Part Name	Remarks	Qty
1	GEN 7422	Cabinet Sub Ass'y		2
2	349 9017 009	Network Ass'y		2
3	302 9019 008	12RW19 Speaker Ass'y	Woofer	2
4	304 9020 006	50RT42 Speaker Ass'y	Tweeter	2
5	146 9258 007	Front Panel		2
6	103 9161 003	Grille Board Ass'y		2
★ 7	513 9291 002	Rating Sheet		1
8				
9				
SCREWS				
101	473 0410 021	Tapping Screw (1) 4x20		20
102	473 0309 022	Tapping Screw (1) 3x16		4
103	473 0306 038	Tapping Screw (1) 3x12	Black	8
PACKING & ACCESSORIES (Not included EXPLODED VIEW)				
51	504 9118 013	Stylen Paper	950x260	2
52	505 9122 015	Poly Cover		2
53	505 9119 002	Envelope		1
54	009 9022 015	Output Cord Ass'y	ℓ = 2m	2
55	503 9228 007	Cushion (Top)		1
56	503 9229 006	Cushion (Bottom)		1
57	513 9284 006	Serial No. Sheet		2
Network Ass'y (Part No.; 349 9017 009)				
71	205 0585 007	2P Terminal		2 ^S
72	009 9026 011	1P Wire Ass'y (RD) ℓ = 250	for Woofer (+)	2
73	009 9027 010	1P Wire Ass'y (BK) ℓ = 250	for Woofer (-)	2
74	009 9028 019	1P Wire Ass'y (OR) ℓ = 270	for Tweeter (+)	2
75	009 9029 018	1P Wire Ass'y (BU) ℓ = 290	for Tweeter (-)	2
76	254 3067 061	Chemicon 2.7μF/50V (Bipole)	CE04P1H2R7KBP (SIL)	2
77	239 9005 057	Choke Coil 0.4mH	Put on Cabi.	2
78	243 2058 013	Wire Wound Resistor 3.3 ohm, 5W	RW98A3H3R3K	2

SCHEMATIC DIAGRAM

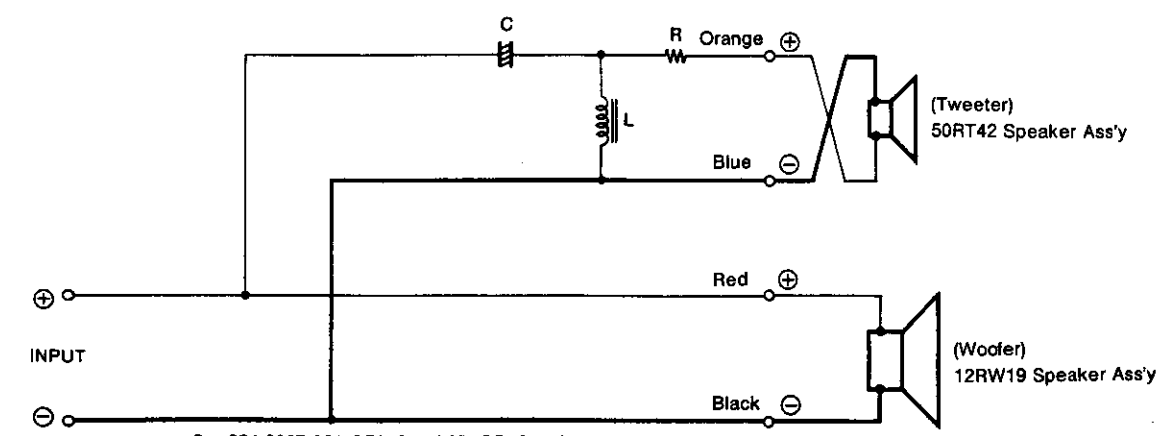

C: 254 3067 061 CE04P1H2R7KBP (SIL) 2.7μF/50V (Bipole)
 R: 243 2058 013 RW98A3H3R3K 3.3 ohm, 5W
 L: 239 9005 057 Choke Coil 0.4mH

SPEAKER SECTION

NETWORK Ass'y

(349 9017 009)

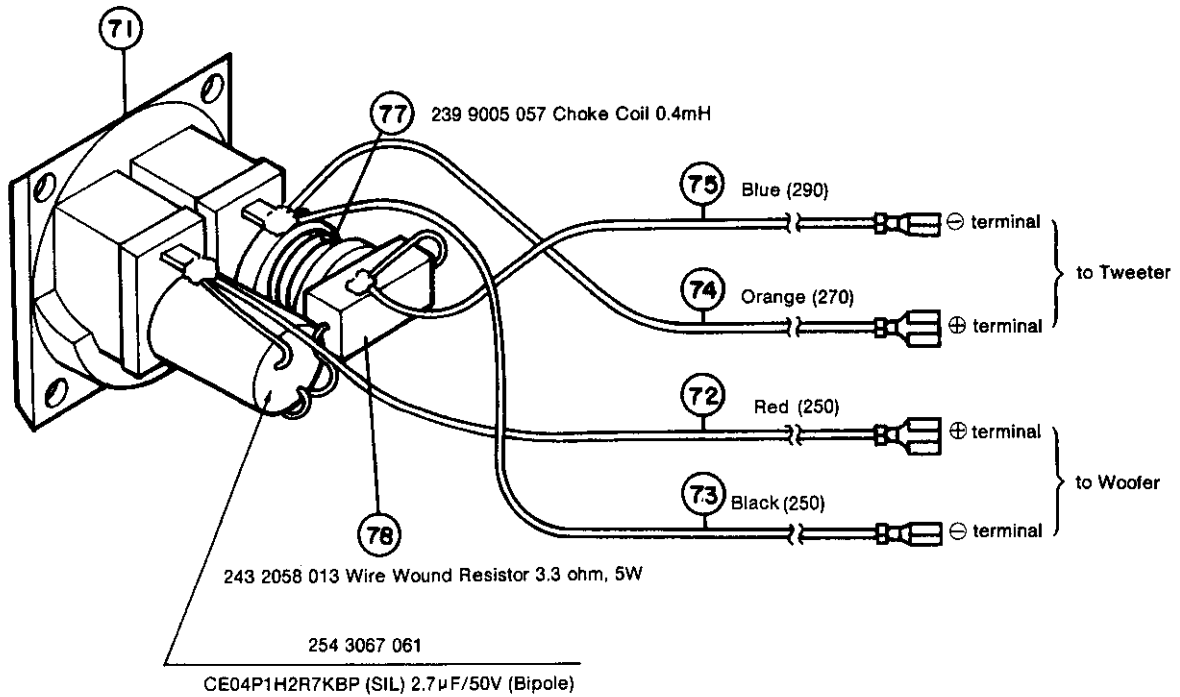

WIRE FORMING

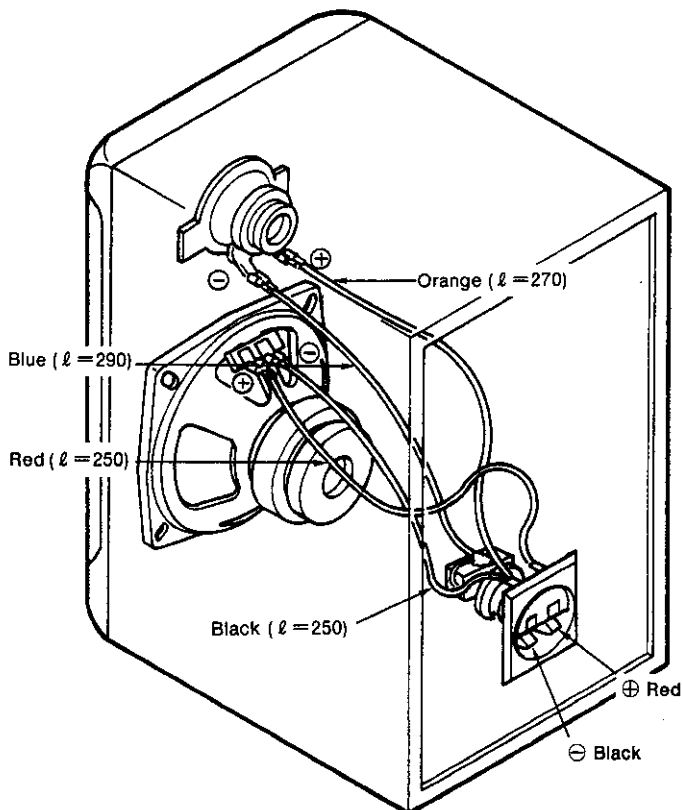

- ① Set the network assembly so that the red pin (+) is at the right, then fasten it using the four 3×12 tapping screws (1).
- ② For the tweeter, connect the orange lead wire to the (+) side (ℓ = 270mm), the blue lead wire to the (-) side. (ℓ = 290mm)
- ③ For the woofer, connect the red lead wire to the (+) side, the black lead wire to the (-) side. (ℓ = 250mm)