

JVC

SERVICE MANUAL

STEREO INTEGRATED AMPLIFIER

MODEL A-X900B



Contents

	Page		Page
Safety Precautions	1-1	5. Removal Procedures.....	1-7
Service Precautions.....	1-1	5-(1) Tone P.C. Board section.....	1-7
Features.....	1-2	5-(2) Gm selector knob replacement.....	1-8
1. Specifications.....	1-2	5-(3) Power transistor section.....	1-8
2. Servicing Method For AWG # 20 Wires		6. Adjustment Procedures.....	1-9
With Clamping Terminals.....	1-3	7. A-X900B Schematic Diagram.....	1-10
3. Names and Functions of Controls.....	1-4	8. Wiring Diagram	1-12
4. Descriptions of Technology	1-6	9. Block Diagram	1-13
■ Gm volume control circuit.....	1-6	Parts List.....	Separate-volume Insertion
■ Gm volume control used in this unit	1-6		
■ Gm selection circuit	1-7		

Safety Precautions

1. The design of this product contains special hardware, many circuits and components specially for safety purposes. For continued protection, no changes should be made to the original design unless authorized in writing by the manufacturer. Replacement parts must be identical to those used in the original circuits. Service should be performed by qualified personnel only.
2. Alterations of the design or circuitry of the product should not be made. Any design alterations or additions will void the manufacturer's warranty and will further relieve the manufacturer of responsibility for personal injury or property damage resulting therefrom.
3. Many electrical and mechanical parts in the product have special safety-related characteristics. These characteristics are often not evident from visual inspection nor can the protection afforded by them necessarily be obtained by using replacement components rated for higher voltage, wattage, etc. Replacement parts which have these special safety characteristics are identified in the parts list of Service manual. Electrical components having such features are identified by shading on the schematics and by (Δ) on the parts list in Service manual. The use of a substitute replacement which does not have the same safety characteristics as the recommended replacement part shown in the parts list in Service manual may create shock, fire, or other hazards.
4. The leads in the products are routed and dressed with ties, clamps, tubings, barriers and/or the like to be separated from live parts, high temperature parts, moving parts and/or sharp edges for the prevention of electric shock and fire hazard.
When service is required, the original lead routing and dress should be observed, and they should be confirmed to be returned to normal, after reassembling.

Service Precautions

1. Before repairing, be sure to discharge the large electrolytic capacitors across a resistor of about 100 ohms/1 watt.
- **When disassembling**
1. When replacing a power transistor or IC, be sure to apply silicone grease to the section of a new transistor or IC which is in close contact with the heatsink, then mount it.
 2. Copper screws (red) are used for improved sound quality.
Be sure to use specified screws.
 3. When removing or stretching wires on the P. C. Board, be sure to restore them to their original routing as far as possible.
 4. When connecting a remote switch, insert it from above as shown in Fig. 2. In this case, press it in sufficiently in order to prevent it from floating during operation.

5. Leakage current check
(Safety for electrical shock hazard)
After reassembling the product, always perform an isolation check on the exposed metal parts of the Products (antenna terminals, knobs, metal cabinet, screw heads, headphone jack, control shafts, etc.) to be sure the product is safe to operate without danger of electrical shock.
Do not use a line isolation transformer during this check.
 - Plug the AC line cord directly into the AC outlet. Using a "Leakage Current Tester", measure the leakage current from each exposed metal part of the cabinet, particularly any exposed metal part having a return path to the chassis, to a known good earth ground. Any leakage current must not exceed 0.5 mA AC (r.m.s.).
 - Alternate check method.
Plug the AC line cord directly into the AC outlet. Use an AC voltmeter having 1,000 ohms per volt or more sensitivity in the following manner. Connect a 1500 ohms 10W resistor paralleled by a 0.15 μ F AC-type capacitor between an exposed metal part and a known good earth ground. Measure the AC voltage across the resistor with the AC voltmeter.
Move the resistor connection to each exposed metal part, particularly any exposed metal part having a return path to the chassis, and measure the AC voltage across the resistor. Now, reverse the plug in the AC outlet and repeat each measurement. Any voltage measured must not exceed 0.75V AC (r.m.s.). This corresponds to 0.5 mA AC (r.m.s.).

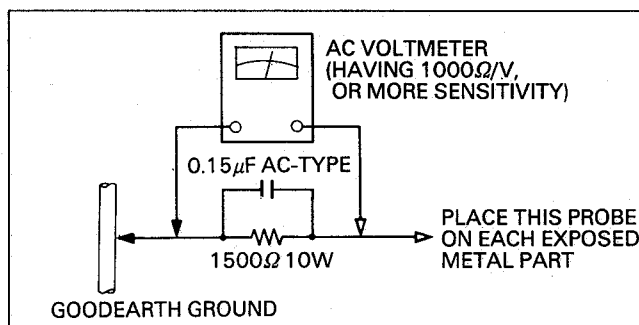

Fig. 1

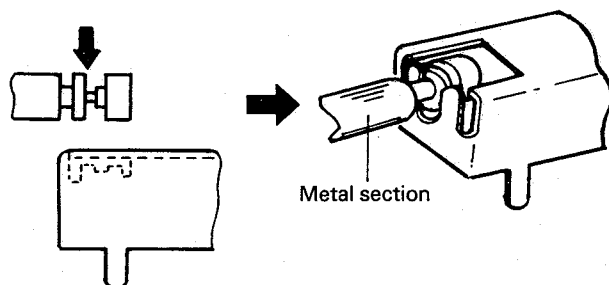

Fig. 2

Note: Set the switch to OFF, then mount or demount it holding the metal section shown above.

Features

- **High S/N ratio achieved through the world's first employment of Gm selector and Gm volume control**
Combined use of the Gm selector and the Gm control Volume enables the practical noise level to be extremely reduced, thus permitting extended dynamic range relative to low output level and making effective use of the merits of a digital system even at micro output level.
- **Dynamic "Super-A" amplifier with Gm driver**
The dynamic "Super-A" amplifier greatly improves the dynamic characteristics regardless of the effect of the load because of current-voltage conversion amplification. The digital sound is played back at high fidelity with an exciting, lively feel.
- **Various I/O terminals for diversified program sources**
DAD only input terminals, TAPE and other terminals are independently attached to the rear or front panel, thus meeting diversified program source requirements.
- **PHONO (MC/MM), DAD, TUNER, AUX, TAPE-1/2 and TAPE-3 jacks on the rear and front panels**
- **High power from large capacity power supply: 120W + 120W**
- **Simple 2-amplifier configuration**
High-gain MC/MM EQ amplifier + high-gain power amplifier.

1. Specifications

OVERALL CHARACTERISTICS

- 120 watts per channel, min. RMS, both channels driven, into 8 ohms from 20 Hz to 20 kHz, with no more than 0.003% total harmonic distortion.**
- 125 watts per channel, min. RMS, both channels driven, into 8 ohms at 1 kHz with no more than 0.0005% total harmonic distortion.**
- 130 watts per channel, min. RMS, both channels driven, into 8 ohms at 1 kHz with no more than 0.7% total harmonic distortion.**
- Total harmonic distortion**
DAD, IN → SP. OUT : 0.003% (20 Hz – 20 kHz, 8 ohms) at 120 watts
- PHONO (MM) IN → SP. OUT**
: 0.007% (20 Hz – 20 kHz, 8 ohms) at 120 watts at VOLUME –30 dB
- Intermodulation distortion**
DAD, IN → SP. OUT : 0.001% (60 Hz: 7 kHz = 4 : 1, 8 ohms) at 120 watts
- Power band width**
DAD, IN → SP. OUT : 7 Hz – 60 kHz (IHF, 0.05%, 8 ohms both channels driven)
- Frequency response**
DAD, TAPE-1, 2, 3, AUX, TUNER : 3 Hz – 100 kHz +0, –3 dB (8 ohms)
- Damping factor** : 80 (1 kHz, 8 ohms)
- Input terminals**
Input sensitivity/impedance (1 kHz)
PHONO (MM) : 2.5 mV/47 kohms
PHONO (MC) : 200 μ V/100 ohms
DAD, TAPE-1, 2, 3, AUX, TUNER : 200 mV/39 kohms

Signal to noise ratio

- | | |
|----------------------------|---|
| PHONO (MM) | : 85 dB/80 dB |
| PHONO (MC) | : 69 dB (250 μ V input) |
| TUNER, DAD | : 109 dB/85 dB |
| AUX | : 109 dB/85 dB |
| TAPE-1, 2, 3 ('66 IHF/DIN) | : 109 dB/85 dB |
| PHONO (MM) | : 83 dB (Rec Out) |
| PHONO (MC) | : 75 dB (Rec Out) |
| TUNER | : 91 dB (Speaker Out) |
| AUX | : 91 dB (Speaker Out) |
| TAPE-1, 2, 3 ('78 IHF) | : 91 dB (Speaker Out) |
| Tone controls | : TREBLE: \pm 8 dB (10 kHz)
BASS : \pm 8 dB (100 Hz) |
| Subsonic filter | : 18 Hz (–6 dB/oct) |
| Loudness control | : 100 Hz, +4 dB |
| Muting level | : –20 dB |

EQUALIZER

- PHONO overload capacity**
PHONO (MM) : 150 mV (1 kHz, 0.002% THD)
PHONO (MC) : 11 mV (1 kHz, 0.003% THD)
- PHONO RIAA deviation**
PHONO (MM) : \pm 0.2 dB (20 Hz – 20 kHz)
PHONO (MC) : same as above
- Total harmonic distortion**
PHONO (MM) : 0.002% (at 7V output, 20 Hz – 20 kHz)
PHONO (MC) : 0.008% (at 7V output, 20 Hz – 20 kHz)

GENERAL

- | | |
|-------------------|--|
| Power source | : See page 3 |
| Power consumption | : See page 3 |
| Dimensions | : 149 (H) x 435 (W) x 406 (D) mm
5-7/8" (H) x 17-1/8" (W) x 16" (D) |
| Weight (net) | : 12.5 kg (27.5 lbs) |

Design and specifications subject to change without notice.

IHF: Initials of the Institute of High Fidelity in the U.S.A.

Power Specifications

Areas	Line voltage & frequency	Power consumption
U.S.A.	AC 120V~, 60 Hz	410 watts, 550 VA
Canada		
Continental Europe	AC 110/120/220/240V~ selectable, 50/60 Hz	250 watts
U.K.		
Australia		
Other Areas	AC 110/120/220/240V~, selectable, 50/60 Hz	250 watts

2. Servicing Method For AWG # 20 Wires With Clamping Terminals

- 1) Application objective → Confirmation of safety
Used to prevent breakage/disconnection troubles of primary and secondary wires within P. C. Boards (or between P. C. Boards). Even when wire breakage/disconnection has actually occurred, a safe air-gap distance between the primary wire and the secondary wire/possibly contacting metal surface can be maintained because the terminal retains the wire sheathing.
- 2) Type of wire used
 - ① 1015 AWG- # 20 (single-coated)
 - ② 1672 AWG- # 20 (double-coated)
- 3) Servicing precautions
 - ① The structural design of this terminal causes its catch to hook onto the P. C. Board, preventing the wire from being easily pulled out. As shown in the figure, use cutting pliers or a similar tool to cut off the ends of the terminal and wire; then remove the remaining terminal clip by melting the soldering.

- 2. Insert the wire until its sheathing contacts section "A" of the terminal and pressure-fit the terminal clamp at three sections of (a), (b) and (c) (section (c) is especially important to assure safety. Exercise particular care to achieve secure clamping).

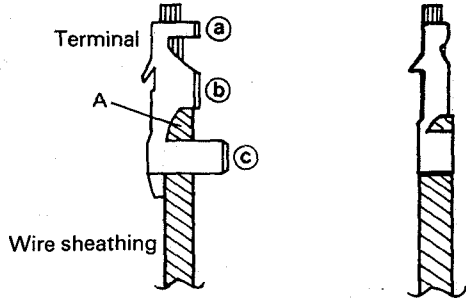

Fig. 4

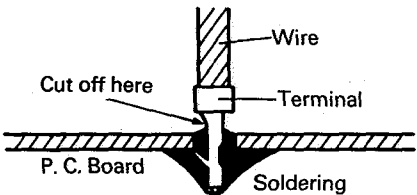

Fig. 3

- ③ Part No., and name
Parts No. : 5298T
Name : CRIMP PIN

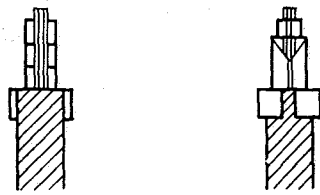
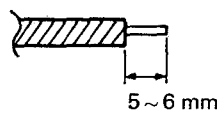

Fig. 5

- ② Prior to soldering the wire onto the P. C. Board, confirm safety by pressure-fitting the terminal to the wire by observing the following procedures.

- 1. Strip off the wire 5 ~ 6 mm from its end.



3. Names and Functions of Controls

1 POWER switch

Press in to turn the power of the unit ON. The POWER indicator placed just above the switch will light. Press again to turn OFF.

2 PHONES jack

Plug the headphones into the jack for private listening.
Note: Plugging in the headphones does not switch off the speaker sound. To listen only through the headphones, set the SPEAKERS switch to OFF.

3 REC SELECTOR

TUNER: Set to this position to listen to another program source while recording a broadcast program.

OFF: Set to this position when not recording or dubbing.

SOURCE: Set to this position to record from source connected to the PHONO, TUNER, DAD, or AUX terminals.

S ▶ 1 ▶ 2/3: Set to this position when dubbing from the tape deck connected to the TAPE-1 terminals to the tape deck connected to the TAPE-2 or -3 terminals, or when recording from the source selected by a source selector button to the tape deck connected to the TAPE-1 terminals.

2 ▶ 1: Set to this position when dubbing from the tape deck connected to the TAPE-2 terminals to the tape deck connected to the TAPE-1 terminals.

3 ▶ 1: Set to this position when dubbing from the tape deck connected to the TAPE-3 terminals to the tape deck connected to the TAPE-1 terminals.

4 TAPE SELECTOR

2: Set to this position to listen to the tape deck connected to the TAPE-2 terminals.

1: Set to this position to listen to the tape deck connected to the TAPE-1 terminals.

3: Set to this position to listen to the tape deck connected to the TAPE-3 terminals.

5 TAPE MONITOR switch

Press in to listen to a tape deck. The indicator located just above the switch will light. In this case, select the required tape deck with the TAPE SELECTOR.

Notes: ● When the indicator is lit, it is not possible to listen to records or radio broadcasts. For this purpose, press this switch again to switch off the indicator.

- When monitoring the recording on the 3-head tape deck (when recording while checking the recording condition upon playback of recorded sounds), press in this switch to light the indicator.

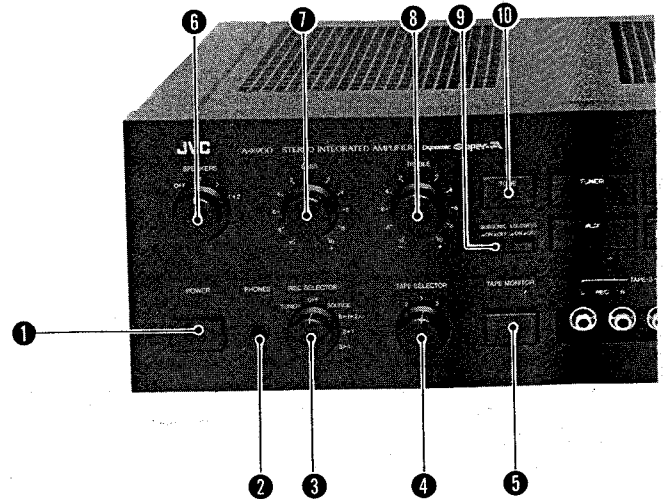

Fig. 1

6 SPEAKERS switch

OFF: Set to this position to switch off the speaker sound for listening through the headphones.

1: Set to this position to listen to the speakers connected to SPEAKERS terminals 1.

2: Set to this position to listen to the speakers connected to SPEAKERS terminals 2.

1 + 2: Set to this position to listen to both speaker systems simultaneously.

Note: Use the speakers with impedance of 8 ohms or more (16 ohms if the 1 + 2 position is used) at the rated speaker impedance of this amplifier is 8 ohms (16 ohms when the 1 + 2 position is used). Speakers with an impedance down to 4 ohms (8 ohms when the 1 + 2 position is used) may be used, in which case the temperature rise of cabinet may not satisfy BS 415 or IEC 65.

Be sure to provide good ventilation, especially when speakers with an impedance of 4 ohms (8 ohms when the 1 + 2 position is used) are used.

7 BASS control

Turn to the right to boost bass response and to the left to decrease bass response.

8 TREBLE control

Turn to the right to boost treble response and to the left to decrease treble response.

9 SUBSONIC switch

ON (■): Press in (■) to eliminate the ultra-low frequency noise when you feel it is annoying.

OFF (□): Normally, set to this position.

10 TONE switch

ON: Press in to ON when adjusting the tone with the BASS and TREBLE controls. The indicators located just above these controls will light.

OFF: Press again to OFF to hear the standard sound (with flat response).

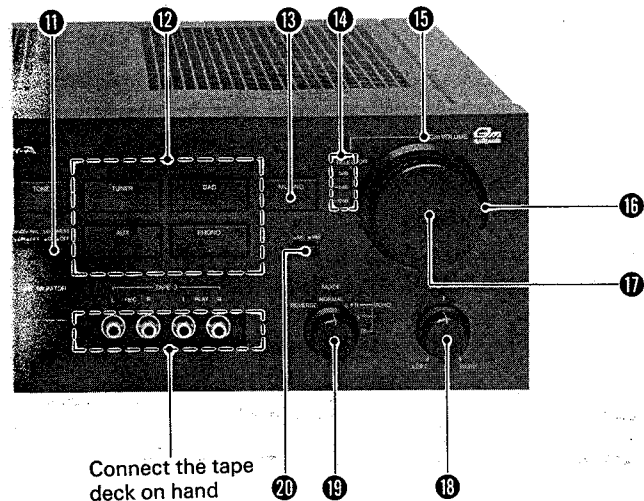

fig. 7

LOUDNESS switch

ON (L): Press in (L) to listen at low volume. You can enjoy powerful play even at low volume.

OFF (□): Press again (□) to eliminate the loudness effect.

Source selector switches

Press the switch corresponding to the required source. The indicator located just above this button will light.

DAD: Press this switch to listen to the DAD (digital source).

PHONO: Press this switch to listen to records.

TUNER: Press this switch to listen to radio broadcasts.

AUX: Press this switch to listen to the source connected to the AUX terminals.

MUTING switch

Press to mute the sound (-20 dB); the right MUTING indicator will light. Use this button when answering the telephone, for example. Pressing again returns the volume level to that adjusted with the Gm VOLUME control.

GM SELECTOR

Setting the Gm selector to -6 dB divides the volume at 0 dB by 4 while setting it to -12 dB divides it by 16. As the Gm selector is turned from 0 dB to -6 dB and -12 dB, residual noise becomes progressively less.

Use the Gm selector together with the Gm VOLUME control.

Protection indicator

The indicator flickers for a few seconds immediately after the unit power is turned ON. However, when operation becomes stable, the condition of the indicator changes from flickering to permanently lit.

In addition, while the indicator is flickering, no sound is emitted from the speakers.

When the protection circuit works during operation, the condition of the indicator changes from lit to flickering to indicate there is an abnormality in the unit.

At this time, turn OFF the power, then remove the case (speaker cord short, etc.) so that the protection circuit is released.

16 Gm SELECTOR switch

The residual noise in the unit is reduced in the order of "0 dB", "-6 dB" and "-12 dB" positions.

Use this switch at an appropriate volume in combination with the Gm VOLUME control.

0 dB: Set to this position when listening at high volume.

-6 dB: Set to this position when listening at medium volume. In this position, the volume is about 1/4 that at "0 dB" position.

-12 dB: Set to this position when listening at low volume. In this position, the volume is about 1/16 that at "0 dB" position.

17 Gm VOLUME control

Controls the volume to speakers or headphones.

In addition, the scale indicates in dB the amount of attenuation with the reference of the maximum volume.

■ Gm VOLUME control

This control system varies the amplification degree differently from a conventional attenuation system. Thus, even when the volume is decreased, high S/N ratio and low distortion rate are obtained with no increase in residual noise.

18 BALANCE control

Balances the volume between the left and right speaker sounds. Usually, set it to the center click position.

19 MODE switch

REVERSE: Set to this position when playing back with the L-ch and R-ch signals reversed.

NORMAL: Normally, set to this position.

MONO L + R: Set to this position when playing back the mixed L- and R-channel signal from both channels.

MONO L: Set to this position when playing back only the L-channel signal from both channels.

MONO R: Set to this position when playing back only the R-channel signal from both channels.

20 MC. MM

MC (moving coil) (L):

Press in (L) when using an MC cartridge whose output is less than 0.5 mV.

MM (moving magnet) (R):

Set to this position when using an MM cartridge or a high-output MC cartridge whose output is more than 0.5 mV.

4. Description of Technology

■ Gm Volume control circuit

In a stereo amplifier, the VR has the important function of determining the playback sound volume.

In a conventional system, the volume is adjusted by attenuating by a VR the level of the input signal applied to the amplifier with a specified voltage gain as shown in Fig. 8. In this system, when the VR is set to the max. volume position, the input signal is applied directly to the amplifier, permitting favorable response. However, although the level of the input signal to the amplifier lowers as the volume is decreased by the VR, the level of the noise emitted from the amplifier does not change and the S/N ratio is degraded with increase of the VR noise as the volume is decreased.

In the Gm volume control circuit used in this unit, the volume is adjusted by varying the voltage gain of the amplifier to remove the drawback in a conventional system.

As shown in Fig. 9, the Gm volume control circuit has a circuit configuration in which the I/O terminals (A) and (B) for the bridged transistors (Q1 - 4) and constant current circuits (C.C.1 - 2) are placed opposite each other.

The input signal to terminal (A), for which the voltages almost equal to its signal voltage appear at the emitters of Q1 and Q2, is output in the form of current from the

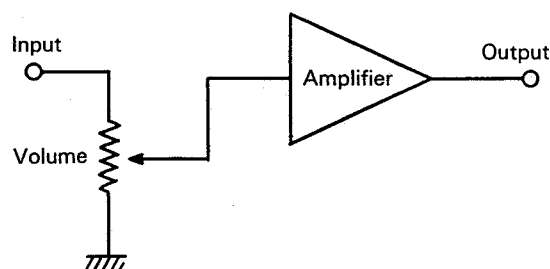

Fig. 8

collectors of Q1 and Q2 and then output to r from the collectors of cascade connected Q3 and Q4. Voltage gain A_v in this circuit is expressed as:

$$A_v \left(= \frac{e_o}{e_i} \right) = - \frac{r}{R_1 + (R_v - r)} \quad (1)$$

When r changes from 0 to R_v , the values in the denominator and numerator of expression (1) vary according to the VR set position, i.e. the gain of the amplifier varies. Thus, the greatest dynamic range and the best S/N ratio are obtained at all times.

■ Gm volume control circuit used in this unit

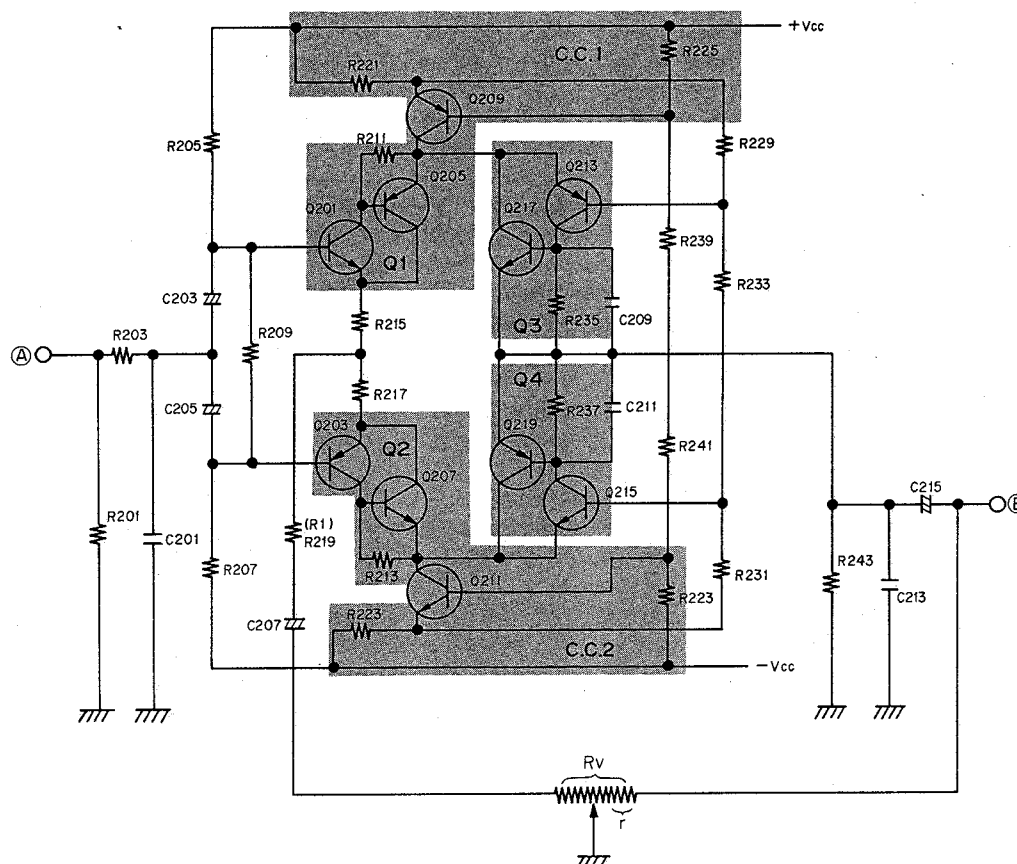

Fig. 9

■ Gm selector circuit

The Gm volume control circuit requires "phase inversion between I/O voltages" and "power amplification for driving speakers". Accordingly, in this unit, an inversion type main amplifier is connected after the Gm volume control circuit.

In the circuit shown in Fig. 10, the voltage gain is adjusted by changing the input resistance by selecting a suitable one from input resistors R259, R261 and R251 (0 dB, -6 dB and -12 dB). Point Ⓐ in Fig. 10 is the imaginary ground point. Thus, the input signal voltage is converted into a current proportional to the reciprocal number of the input resistance value. Then, it is converted into a voltage with feedback impedance (Z) again. In this manner, voltage amplification is performed.

In this unit, as the voltage gain of the main amplifier is controlled in the above manner, the characteristics are improved as follows:

- (1) Residual noise is reduced.
- (2) The basic characteristics are upgraded since the excessive gain is turned to the increase of the NFB amount.

Fig. 11 shows the noise characteristic in the unit. It can be seen that the S/N ratio is improved more than 20 dB at a practical VR position as compared with conventional systems.

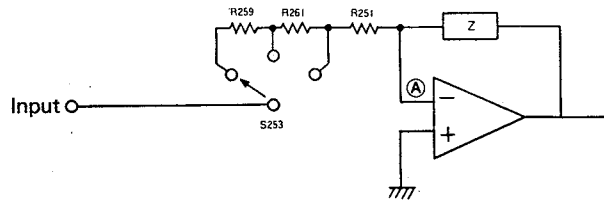

Fig. 10

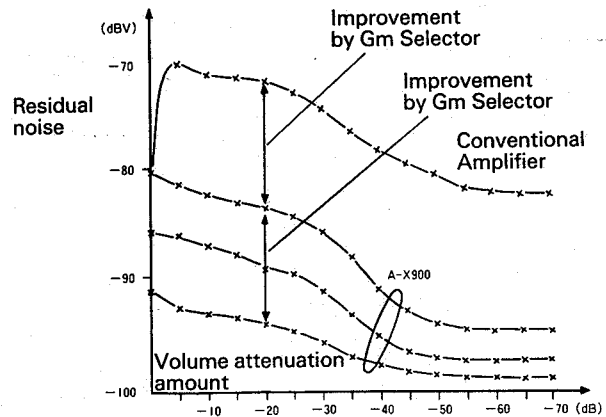

Fig. 11

5. Removal Procedures

5-(1) Tone P.C. Board section

Remove 4 screws (2 on each cover side) and 3 screws on the rear panel. Then, remove the metal cover.

1. Remove 3 screws from the upper part of the front panel and 3 screws from the lower part.
2. Remove the front panel. Pull out the volume knob, and remove the nut (Fig. 12).

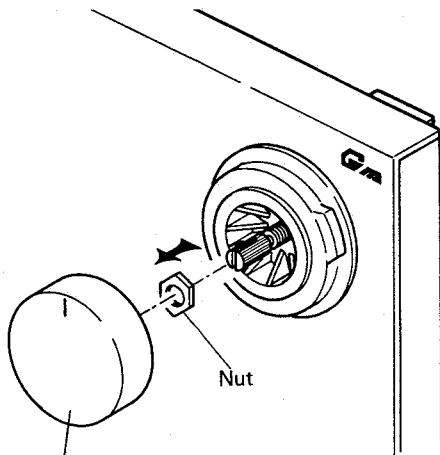

Fig. 12

3. Pull out the treble and bass knobs and remove their nuts (Fig. 13).
4. Remove the screws on both sides of the tone switch and remove the tone P.C. Board (Fig. 13).

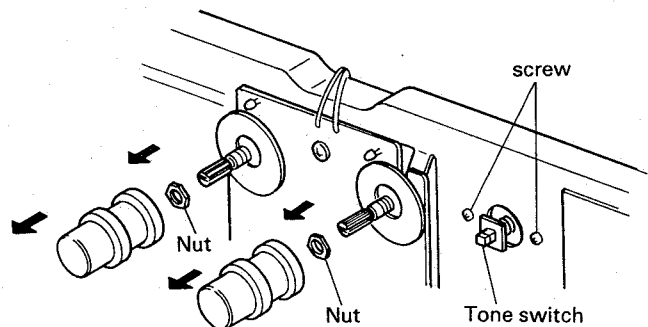

Fig. 13

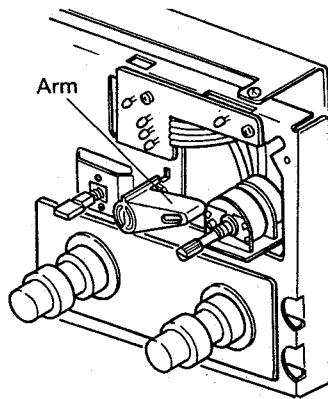

Fig. 14

NOTES: Install in the reverse order to removal.

When installing the front panel;

- ① Set each L.E.D. in the proper position.
- ② Position the arm horizontally as shown in Fig. 14, and install the master volume knob so that its pointer indicates the -12 dB position.

5-(2) Gm Selector knob replacement

1. Remove the front panel (Refer to 5-1.).
2. Peel off the bond fixing 2 speed nuts inside the front panel.

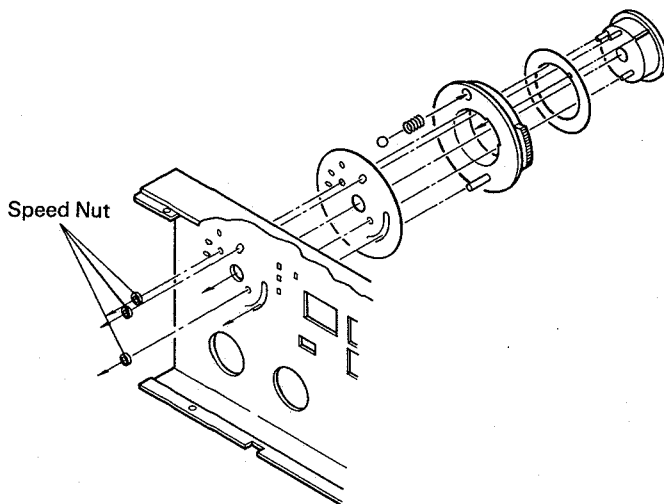

Fig. 15

3. Holding the Gm Selector knob assembly on the front panel to prevent it coming apart (ball bearing, etc.), remove 3 speed nuts and then the Gm Selector knob (Fig. 15).

5-(3) Power Transistor Section

1. Remove 5 screws from the bottom cover.
2. Remove the bottom cover (Fig. 16).

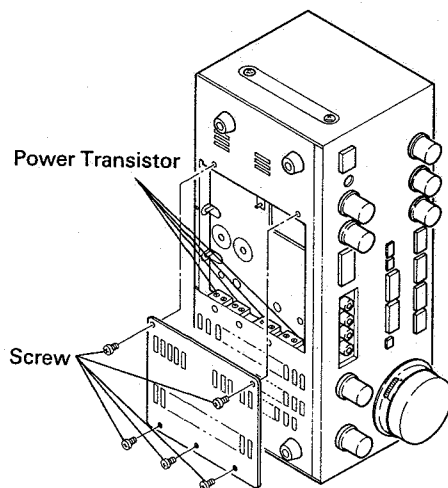

Fig. 16

6. Adjustment Procedures

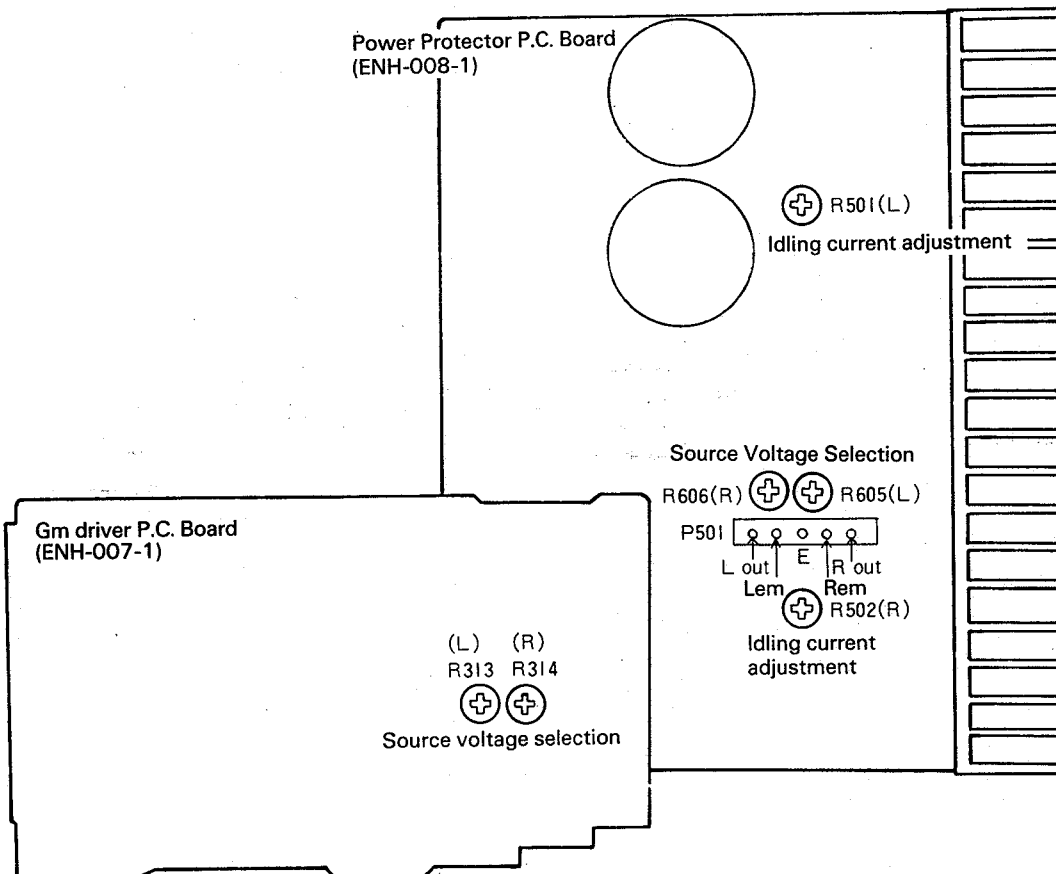

Fig. 17

■ Idling current adjustment

- (1) Before turning ON the power, turn the semi-fixed resistors (R501 for L channel and R502 for R channel) on the power amplifier P.C. Board fully counterclockwise.
- (2) After turning ON the power, adjust the voltages between L out (-) and Lem (+) and between R out (-) and Rem (+) in P501 with semi-fixed resistors R501 and R502.
 - { When adjusting 1 minute after power ON: 5 mV
 - { When adjusting 10 minutes after power ON: 11 mV

■ Center voltage adjustment

Adjust the voltages between the following terminals to 0 ± 1 mV with R313 (L channel) and R314 (R channel).

- { E (ground) - L out in P501: R313
- { E (ground) - R out in P501: R314

■ Voltage selector circuit adjustment

- (1) Before turning ON the power, turn the semi-fixed resistors (R605 for L channel and R606 for R channel) on the power amplifier P.C. Board fully counterclockwise.
- (2) After turning ON the power, apply a 20 Hz sine wave to either the L or R channel input, connect a 7-ohm dummy load (distributed by JVC Stereo Division) as the speaker load, and adjust the Gm volume control so that 34V output is obtained. At this time, decrease the input level of the other channel by the BALANCE control.
- (3) Slowly turn the semi-fixed resistor (R605 for L channel or R606 for R channel) clockwise and stop it at a position where the output waveform begins to be clipped on the oscilloscope.
- (4) Change the load from 7 ohms to 8 ohms and check the output waveform is not clipped. This adjustment is performed for both channels, separately.

Note: When performing measurements in these adjustments, be sure to disconnect the probe and enclosure (metal case) of the measuring instrument from the ground of the amplifier unit (A-X900) and the ground of any other measuring instrument so that measurements can be made with the instrument electrically independent.

7. A-X900B Schematic Diagram

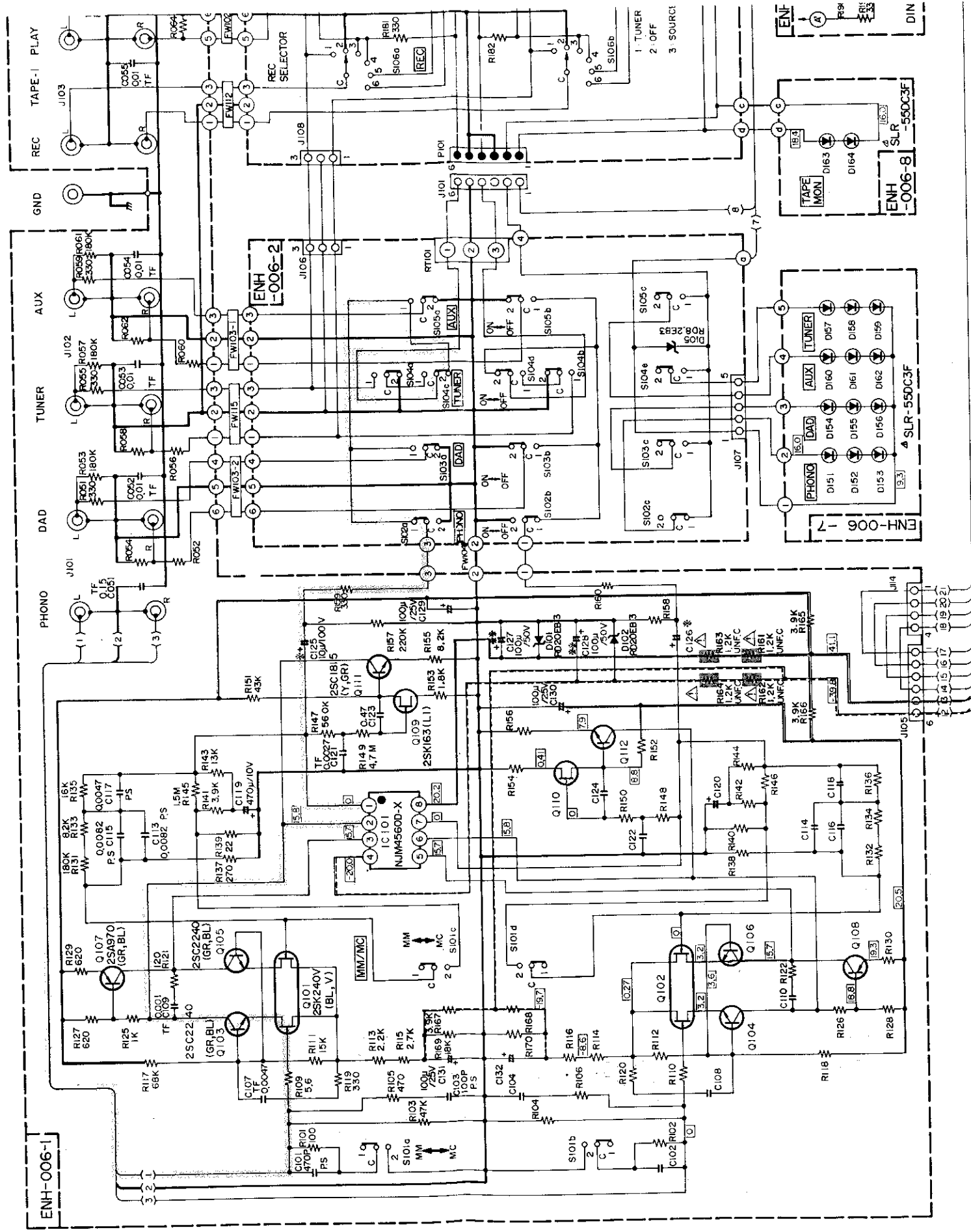

Note:

1. — indicates B (+).
2. - - - indicates B (-).
3. [Symbol] indicates the signal path.
4. The voltage measured by a multi-meter (inner resistance: 20 kΩ/V) at non-signal condition is shown in the following form.
Example: 0.3 (Unit: V)
5. In the transistor parts and the measured voltage figures, only one channel is indicated when left and right channels are identical.
The parts marked Δ ([Symbol]) are important for safety reasons.
6. As this diagram gives only reference circuits, the circuit and the circuit constant are subject to change without notice due to technical improvement.
7. Indicator connection is shown in the right-hand figure.

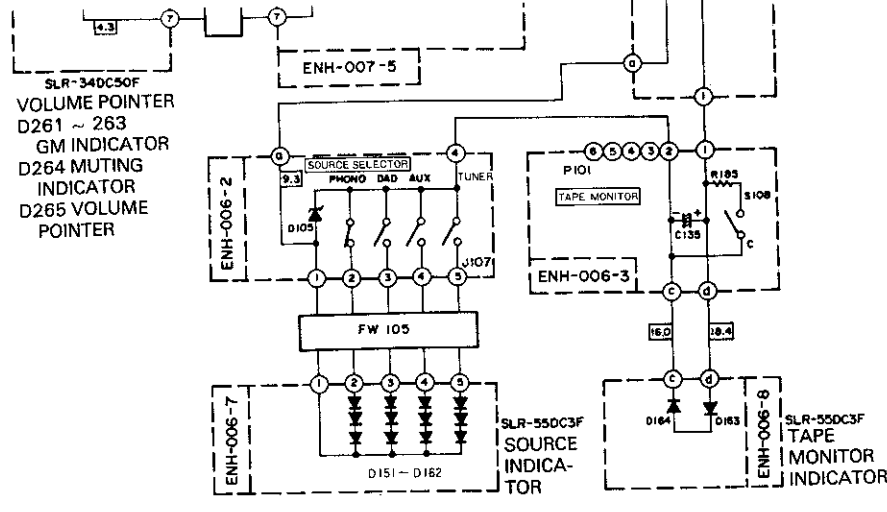

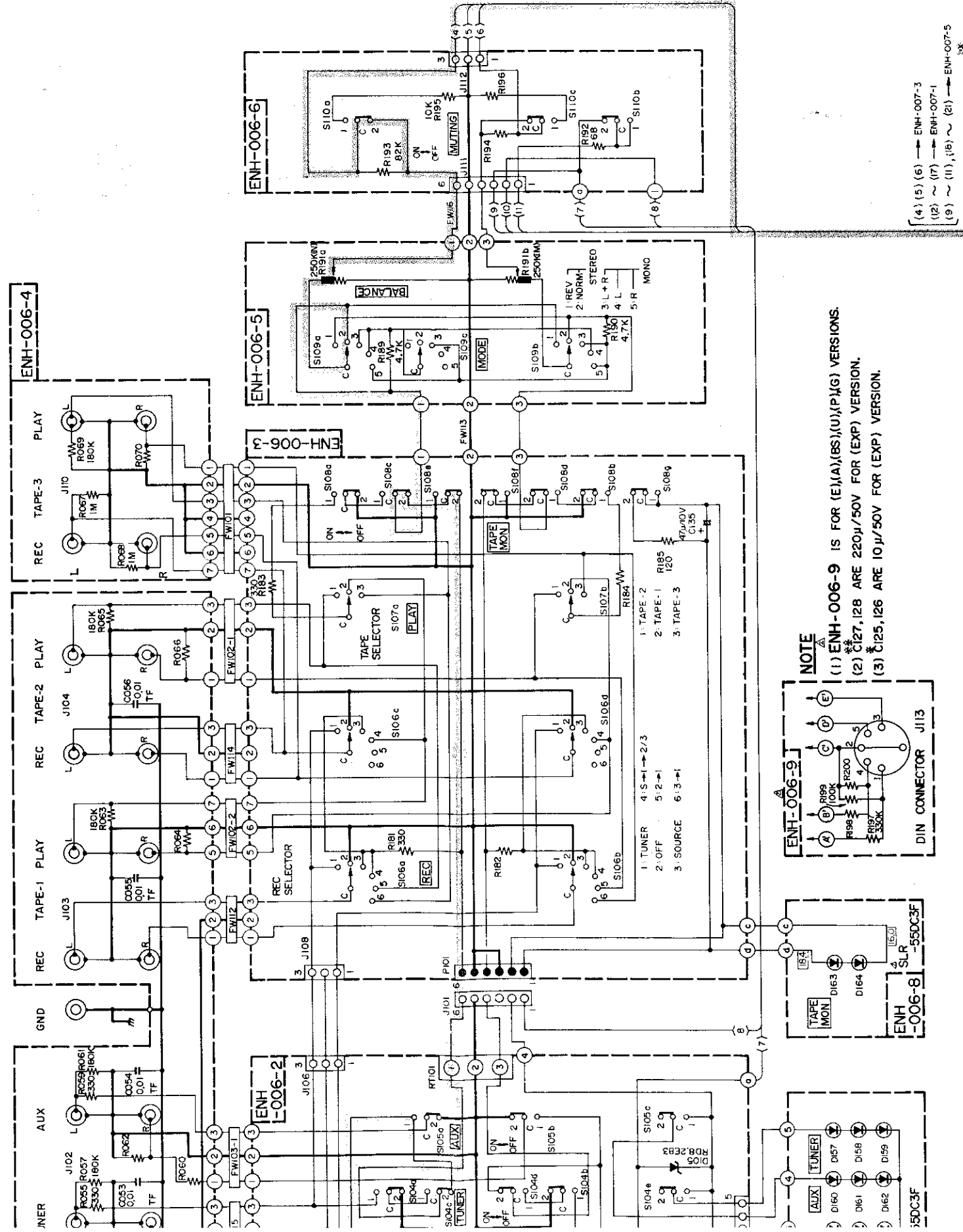

NOTE
 (1) ENH-006-9 IS FOR (E),(A),(BS),(U),(P),(G) VERSIONS.
 (2) C127, 128 ARE 220µ/50V FOR (EXP) VERSION.
 (3) C125, 126 ARE 10µ/50V FOR (EXP) VERSION.

(4) (5) (6) → ENH-007-3
 (12) ~ (17) → ENH-007-1
 (9) ~ (11), (16) ~ (21) → ENH-007-5

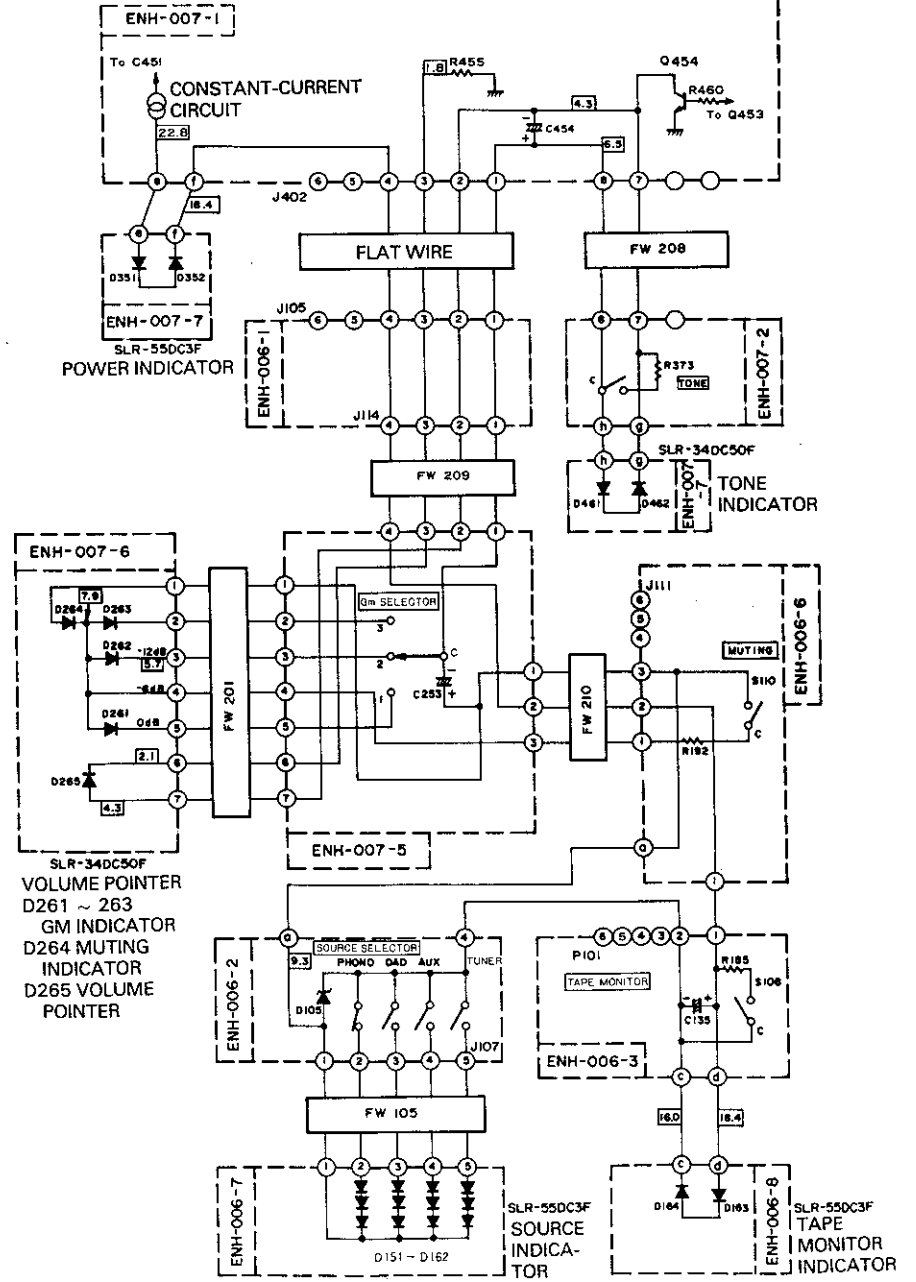

X (14) (15) (16) — ENH-006-6 (1) (10) (11) — ENH-006-6 (12) — ENH-006-1

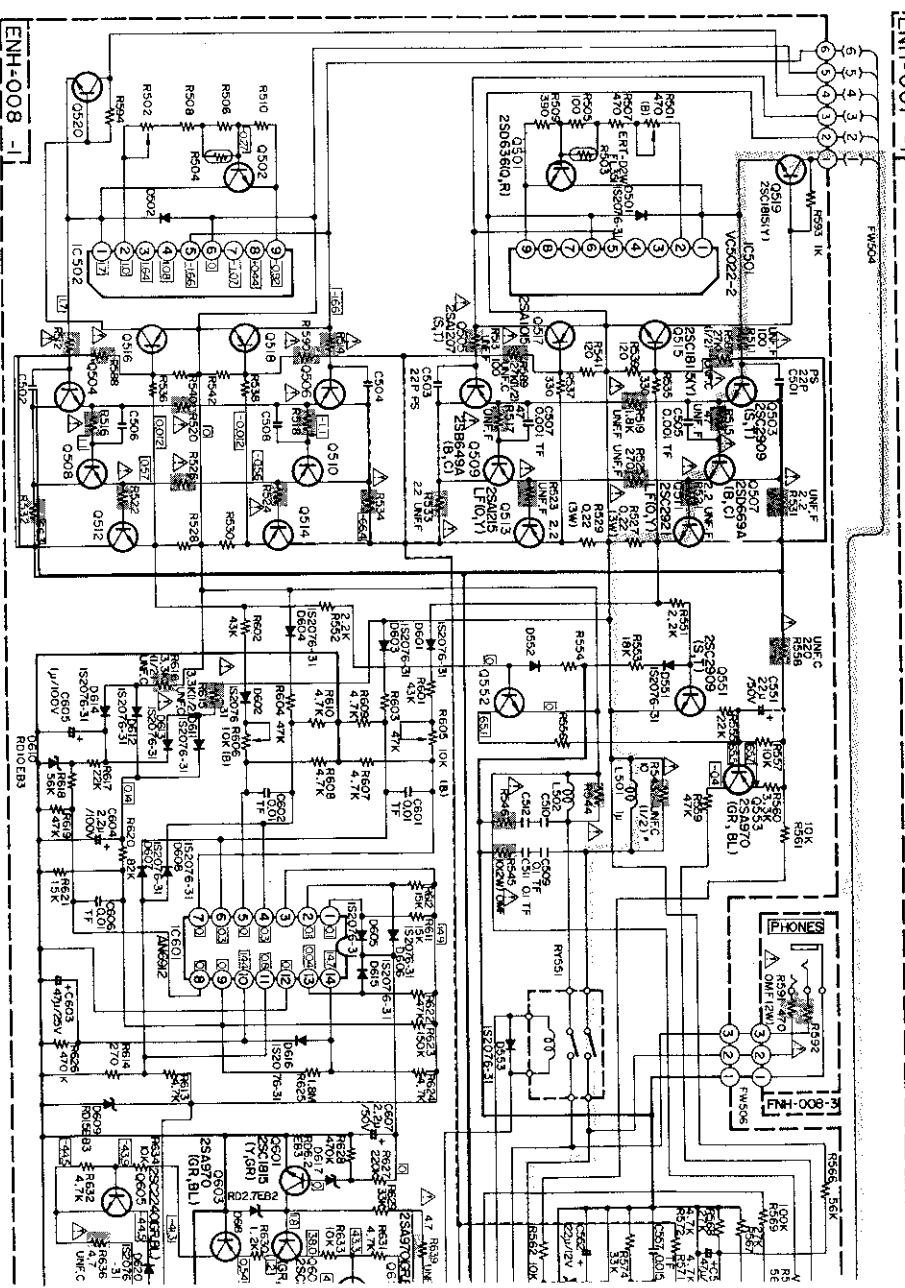
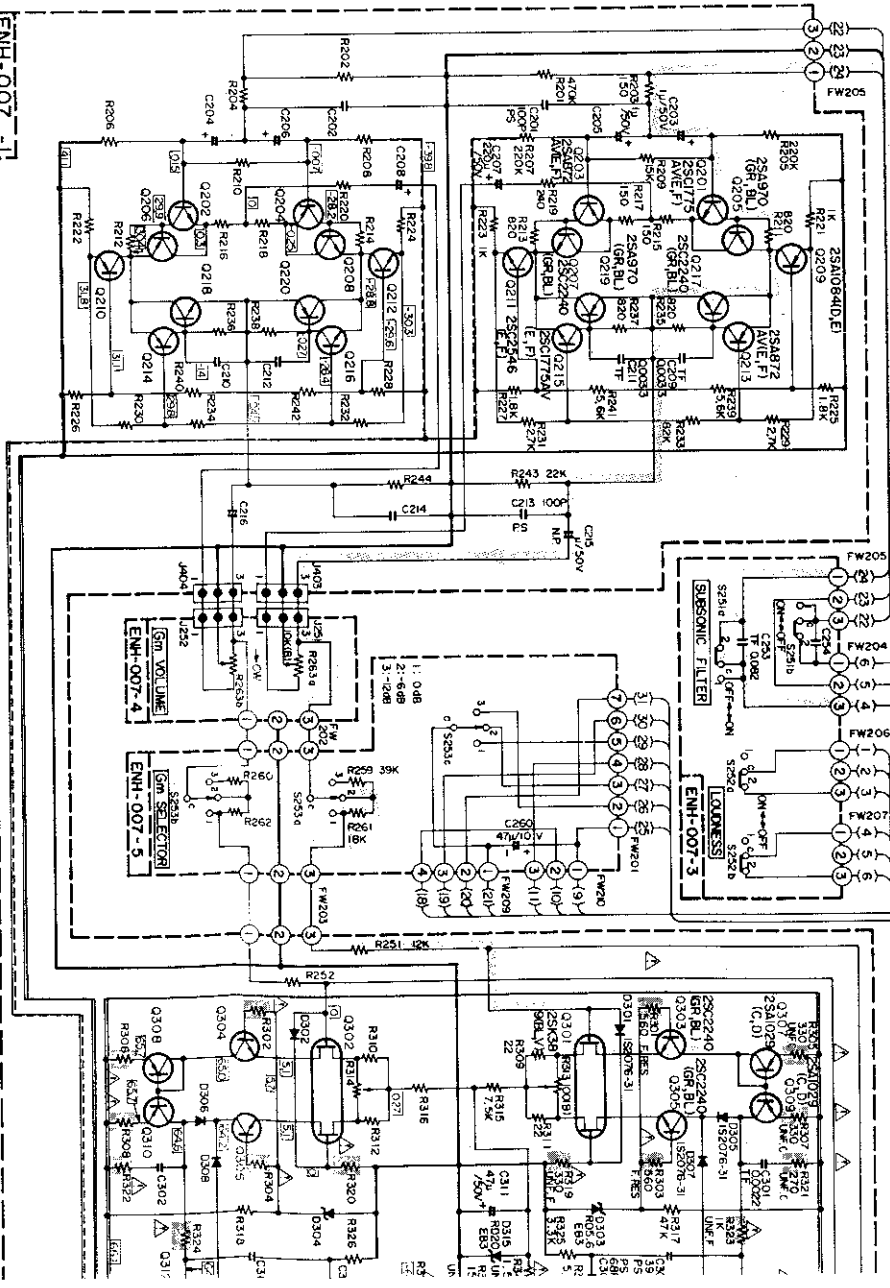

(E), (A), (BS) (E) FOR EUROPE : ~ 220V, 50HZ
 (A) FOR AUSTRALIA : ~ 240V, 50HZ
 (BS) FOR UK : ~ 240V, 50HZ

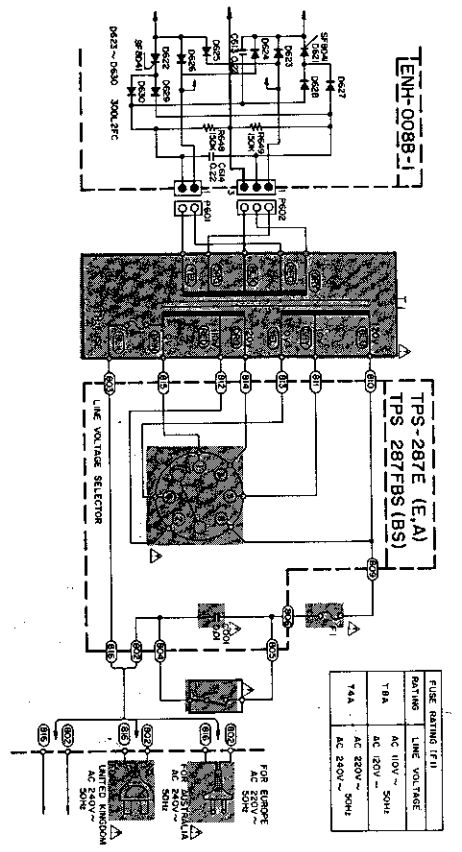

FUSE RATING (F1)	
RATING	LINE VOLTAGE
T8A	AC 110V ~ 200V
T4A	AC 220V ~ 240V

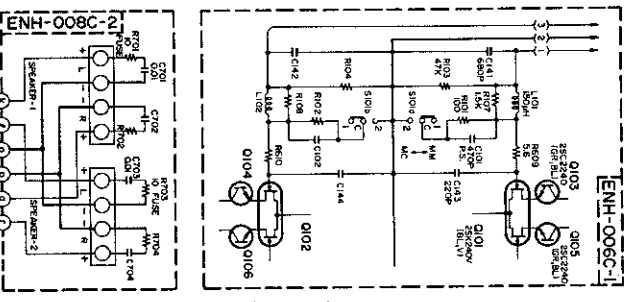

(G) FOR WEST GERMANY : 220V, 50HZ

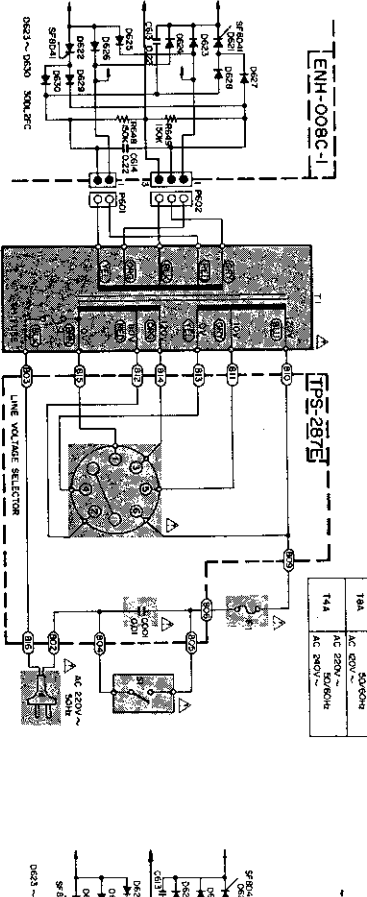

FUSE RATING (F1)	
RATING	LINE VOLTAGE
T8A	AC 110V ~ 200V
T4A	AC 220V ~ 240V

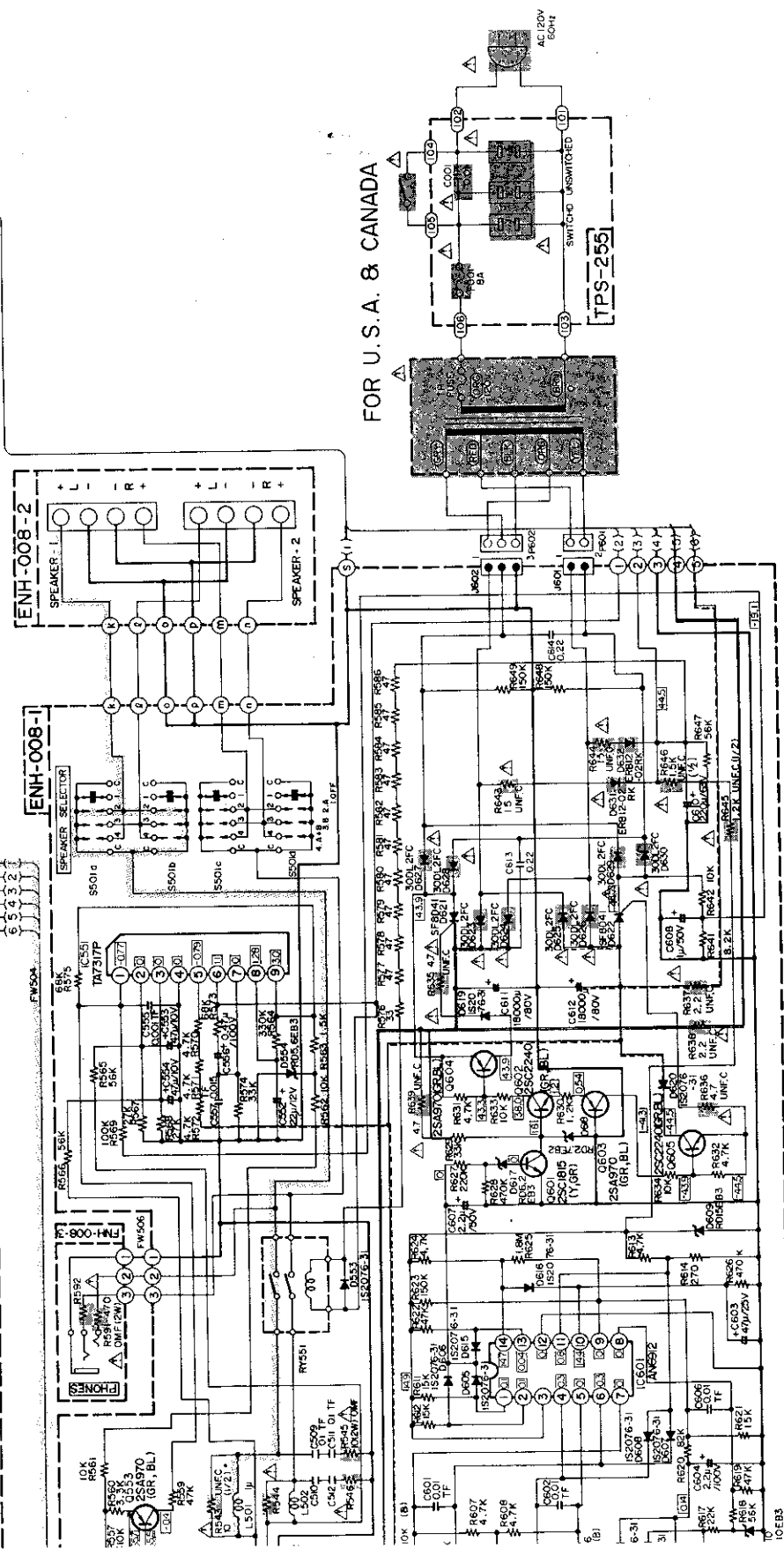
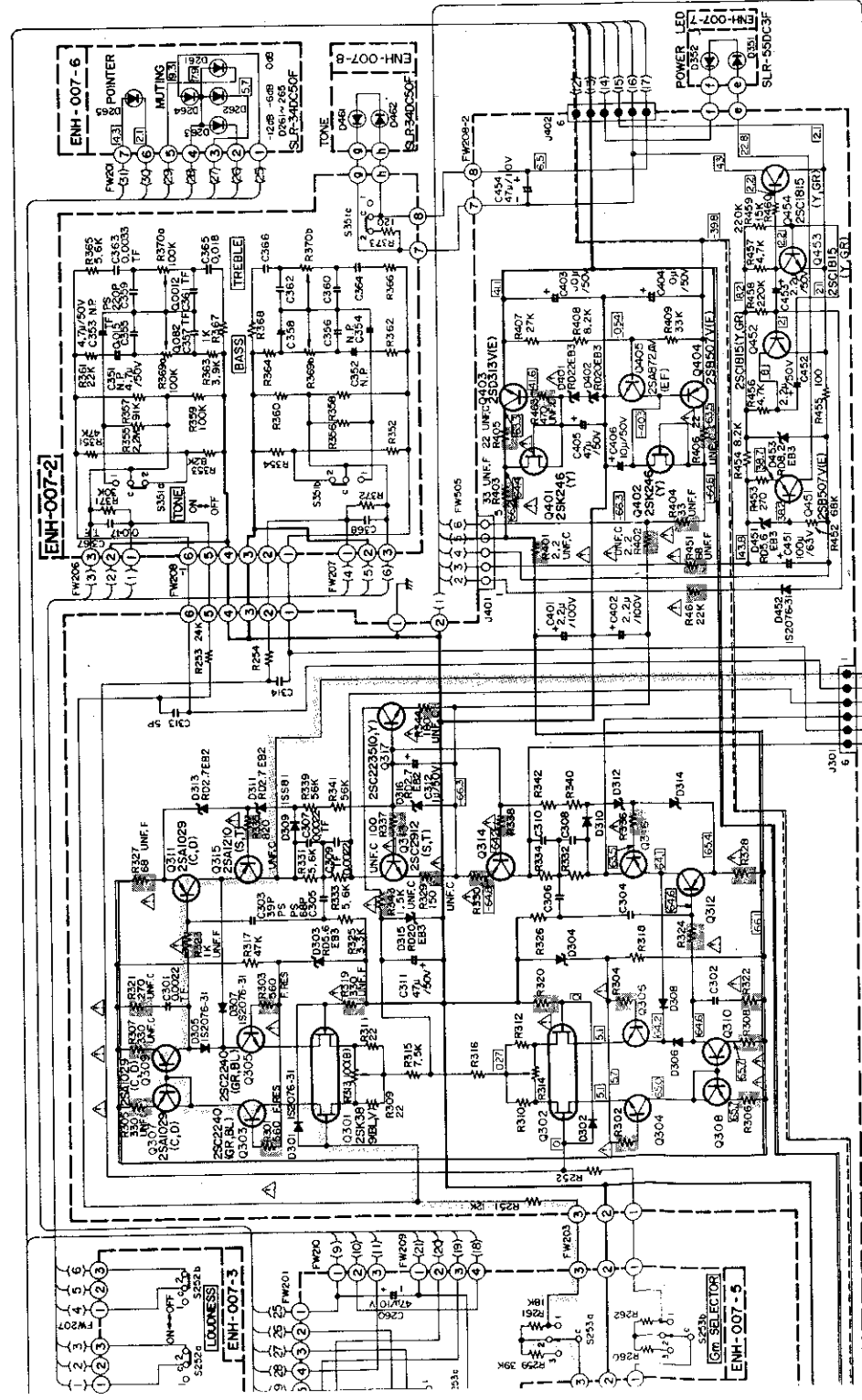

FOR U.S.A. & CANADA

(U), (P) (U) FOR OTHER COUNTRIES
(P) FOR PACEX

ANY : 220V, 50HZ

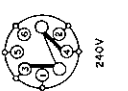
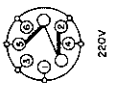
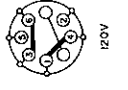
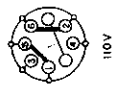
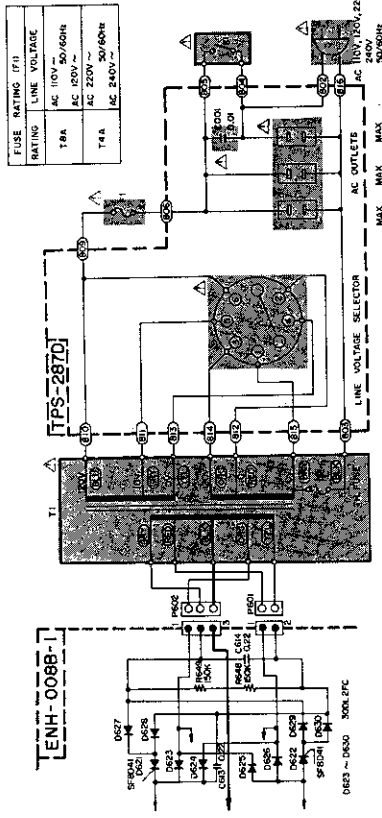
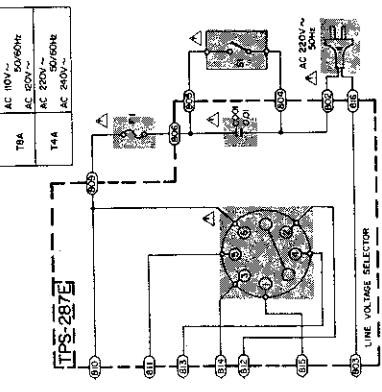

TOP VIEW

8. Wiring Diagram

For U.S.A., Canada

For U.K., Australia, Europe, Germany

U.S. Military Market, other Countries

Except U.S.A., Canada

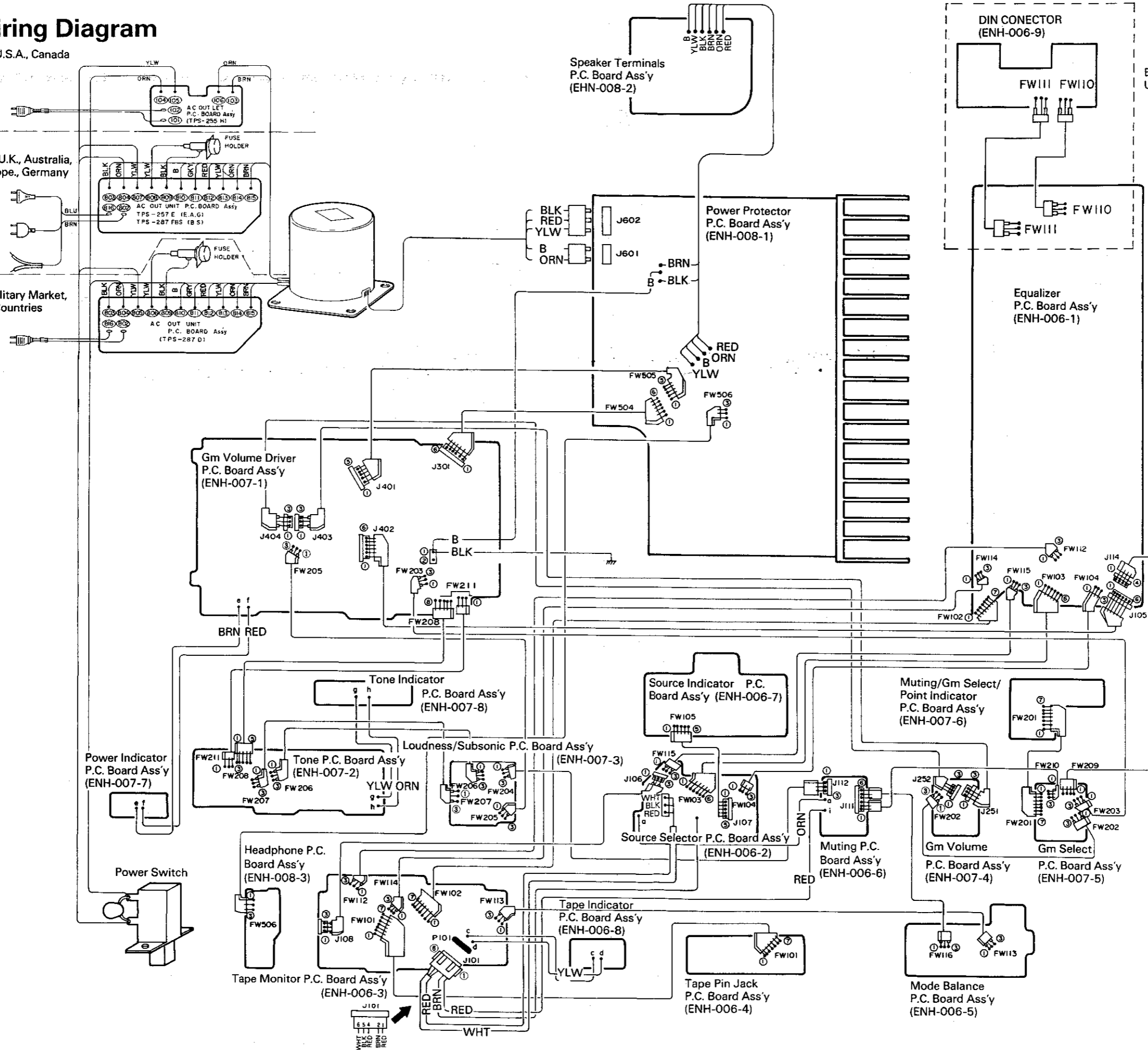

- Note:**
 BLK: BLACK
 BRN: BROWN
 RED: RED
 ORN: ORANGE
 B: BLUE
 GRY: GRAY
 WHT: WHITE
 YLW: YELLOW

Note:
 Two flat wires (F116, 210) connect J111 as below.

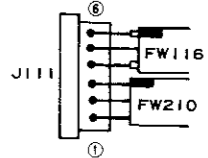

Fig. 18

9. Block Diagram

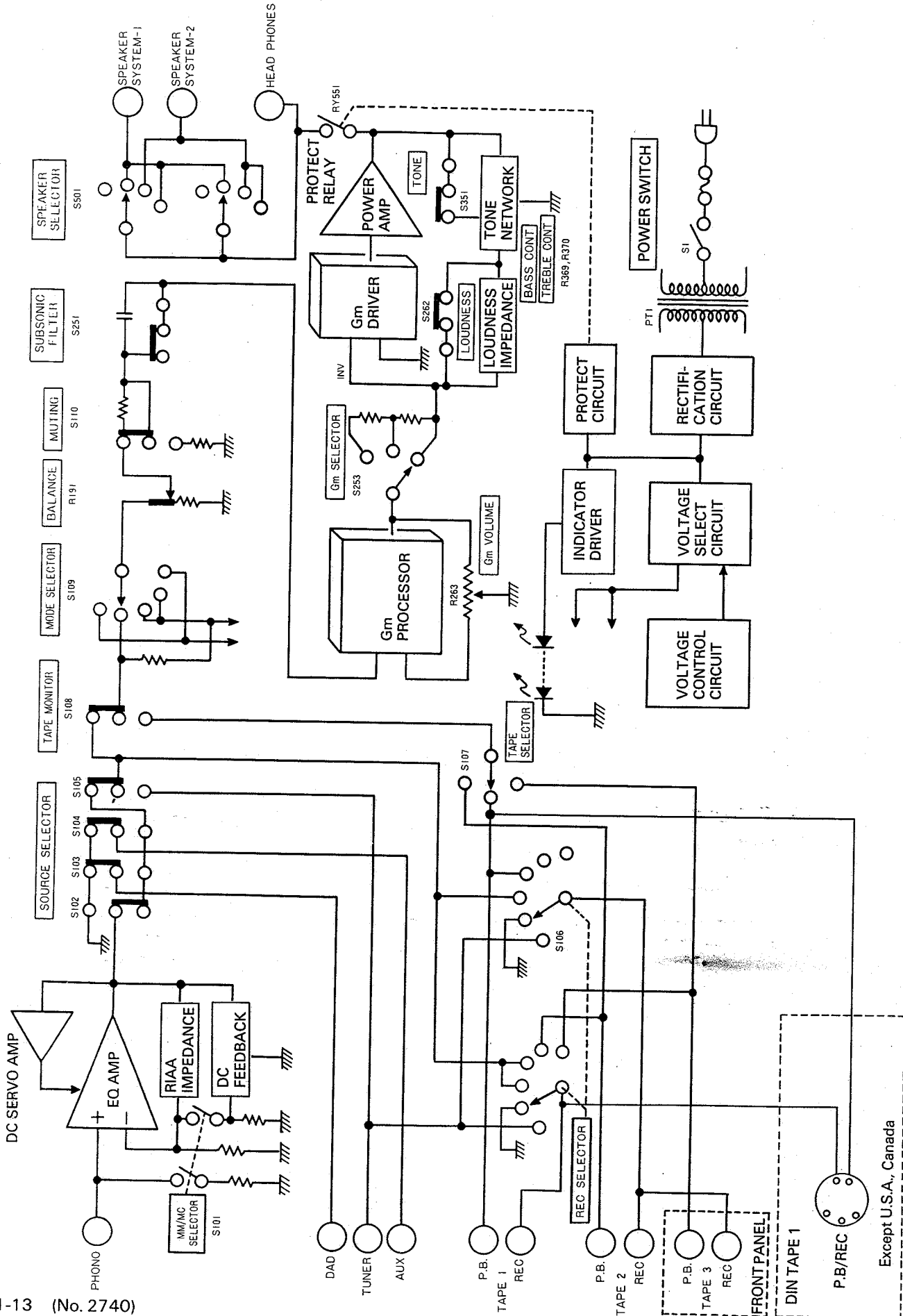

Fig. 19

PARTS LIST

Contents

1. Main Parts Locations.....	2-2
2. Exploded View and Part Numbers List	2-3
3. Printed Circuit Board Ass'y and Parts List.....	2-6
3-(1) ENH-006 Equalizer P.C. Board Ass'y	2-6
3-(2) ENH-007 Gm Volume Driver P.C. Board Ass'y	2-10
3-(3) ENH-008 Power Amplifier P.C. Board Ass'y	2-14
3-(4) TPS-255 AC Outlet P.C. Board Ass'y.....	2-18
3-(5) TPS-287 Voltage Selector P.C. Board Ass'y.....	2-18
4. Packing Materials and Part Numbers	2-19
5. Accessories List	2-20

I. Main Parts Locations

Front View

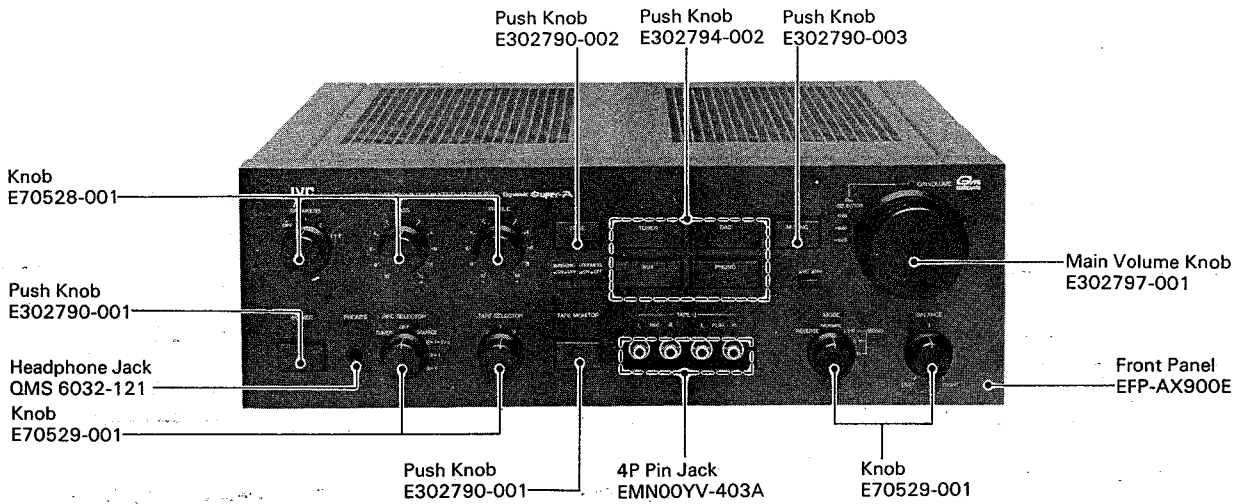

Top View

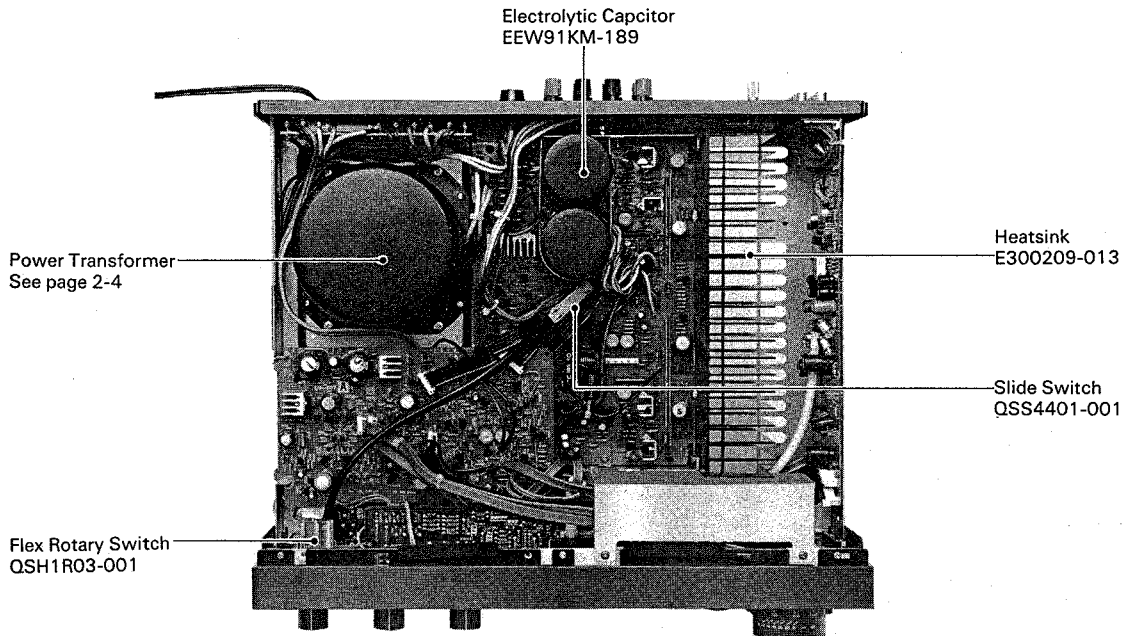

Rear View

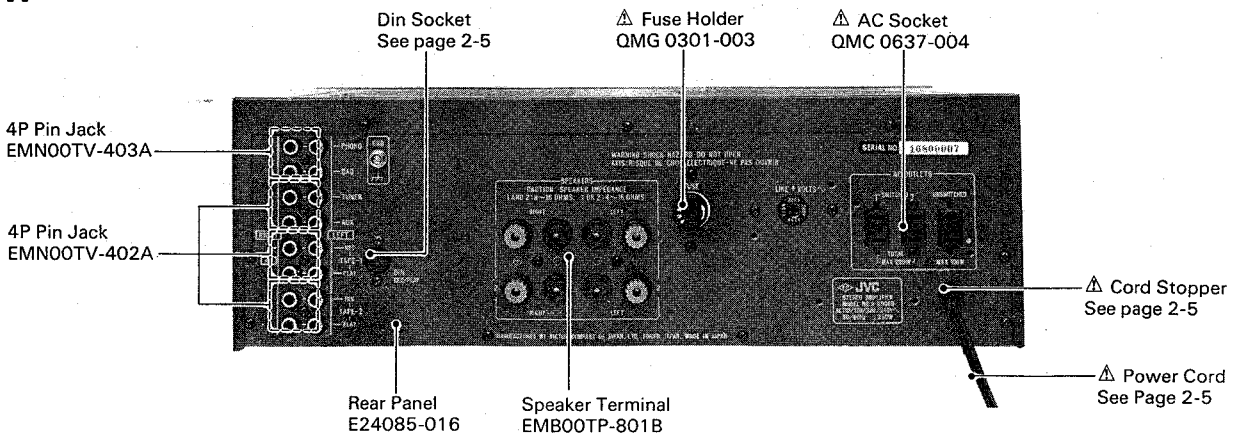

The Marks for Designated Areas

J..... U. S. A.
 C..... Canada
 E..... Europe
 G..... West Germany
 A..... Australia
 P, PG..... U. S. Military Market
 BS..... U. K.
 U..... Other Countries

No mark indicates all areas.

No.	Part Number	Part Name	Q'ty	Description	Area
1	EFP-AX900E	Front Panel Ass'y	1		
2	E10710-006	Chassis Base	1		
3	E10887-001	Front Bracket	1		
4	E24507-001	Metal Cover	1		
5	E24085-016	Rear Panel	1		J, C
6	E24085-018	Rear Panel	1		U, P
6	E24085-017	Rear Panel	1		E, A, BS, G
6	ETP4300-01JA	Power Transformer	1		J, C
6	ETP4300-01FA	Power Transformer	1		E, G, A, U, P
6	ETP4300-01FABS	Power Transformer	1		BS
7	E302098-001	Bottom Cover	1		
8	E302797-001	M. Volume Knob	1		
9	E302934-001	Knob Bush	1		
10	E70531-001	Spacer (A)	1		
11	E302799-001	Knob Ring Ass'y	1		
12	E66722-025	Spring	1		
13	E68428-004	Steel Ball	1		
14	E71463-001	Spacer (B)	1		
15	E302790-004	Push Knob Ass'y	2	POWER, TAPE	
16	E70913-001	JVC Mark	1		
17	E302802-001	Pin Jack Cover	1	Accessory	
18	SDSB3008MCP	Tapping Screw	3	Front Panel	
19	E70978-001	Mark	1		
20	E70527-003	Knob Escutcheon	1	MC. MM	
21	E70527-002	Knob Escutcheon	1	Sub. & Loud.	
22	E302794-002	Push Knob Ass'y	1		
23	E302790-006	Push Knob Ass'y	1	MUTING	
24	SSST 3008Z	Screw	2		
25	E302790-005	Push Knob Ass'y	1	TONE	
26	E302804-001	S. Fitting (R)	1		
27	E302804-002	S. Fitting (L)	1		
28	E60912-003	Speed Nut	1		
29	EX0070010N50S	Spacer	2	Front Panel	
30	E66052-001	Special Screw	3	Front Panel	
31	E60912-003	Speed Nut	3		
32	E70529-002	Knob	4	MODE, BALANCE	
33	E70533-001	Arm	1		
34	E71260-002	Spacer	2		
35	SBSB3008M	Tapping Screw	49		
36	E65119-001	Special Screw	10		
37	E70077-001	Screw	2		
38	E69805-004	Push Knob	3	SUB., LOUD.	
39	E302803-001	Escutcheon	1	Pin Jack	
40	QVZ1709-011	Variable	2	BASS, TREBLE	
41	E70528-003	Knob	3		
42	E70535-001	LED Holder	2	Power, T.Monitor	
43	E302805-001	LED Holder	2	LED-Source	
44	QST2241-E02	Push Switch	1	SUB, LOUD.	
45	QST5462-E01	Push Switch	1	TUN., DAD, AUX, PH.	
46	QST5102-E03	Push Switch	1	MUTING	
47	QSR6223-201	Rotary Switch	1	Gm Selector	
48	QVZ1224-001	Variable	1	Gm Volume	
49	QSP 1110-310	Push Switch	1	Power	J, C
49	QSP 1106-002	Push Switch	1	Power	U, P, E, A, G
49	QSP 1106-002BS	Push Switch	1	Power	BS

No.	Part Number	Part Name	Q'ty	Description	Area
50	E70534-001	Push Shaft	2	(Large)	
51	E70534-002	Push Shaft	2	(Small)	
52	QSR6346-252	Rotary Switch	1	REC SELE.	
53	QSR6223-252	Rotary Switch	1	TAPE SELE.	
54	QST5102-E04	Push Switch	1	TAPE MONI.	
55	QMS6302-121	Headphone Jack	1		
56	E61660-004	Special Screw	4		
57	QSS4201-504	Slide Switch	1		
58	E302942-001	Shield Bracket	1		
59	QSH1R03-001	Flex Rotary SW	1	SPEAKER	
60	ENH-006	EQ. Circuit Board Unit	1	See page 2-6	
61	QSH1P07-004	Flex Push	1		
62	QST5101-E02	Push Switch	1	Tone	
63	ENH-008-1	Power Amp. Circuit Board Unit	1	See page 2-14	
64	ENH-007-1	Gm Volume Circuit Board Unit	1	See page 2-10	
65	ENH-006-9	DIN Circuit Board Unit	1	See page 2-6	
66	EX0120005R20S	Spacer	2		
68	E47227-008	Foot	4		
69	SBSB3010M	Tapping Screw	4		
70	E65119-005	Special Screw	1		
71	E65389-004	Screw	4		
73	TPS-255H	AC Outlet Unit	1	See page 2-18	J, C
74	QMF61U1-8R0	Fuse	1		J, C
75	EMB00TP-801C	SPK. Terminal Unit	1		
76	SDSB 3008M	Screw	4		
77	E03623-003	DIN Socket	1		
78	E70078-001	GND Terminal	1		
79	QMP1200-200	Power Cord	1		J
79	QMP1900-200	Power Cord	1		C
79	QMP3900-200	Power Cord	1		E, G
80	QMP2560-244	Power Cord	1		A
80	QMP9017-008BS	Power Cord	1		BS
80	QMP7600-200	Power Cord	1		U, P
80	QHS3876-162	Cord Stopper	1		J, C, U, P, E, A, G
80	QHS3876-162BS	Cord Stopper	1		BS
81	E65778-007	Spacer	2		
82	QHW4110-001	Wiring Clamp	1		
83	QVD7A7M-1F5V	Variable	1	BALANCE	
84	QSR6345-252	Rotary Switch	1	MODE	
85	E69999-002	Bushing	1		
86	E3400-356	Felt Spacer	1		
87	EMN00YV-403A	4 pin Jack	1	TAPE-3	
88	E302102-001	Heatsink Bracket	1		
89	E302806-001	Heatsink Bracket	1		
90	E303494-001	Bracket	1		
91	E65778-008	Spacer	2		
92	E300209-013	Heatsink	1		
93	EMN00TV-403A	4 pin Jack Ass'y	1	PHONO, DAD	
94	EMN00TV-402A	4 pin Jack Ass'y	1	TUN, AUX, TA.-1, TA.-2	
95	TPS-287	P.Circuit Board Unit	1	See page 2-18	U, P, E, A, G, BS
96	E302104-002	AC Cover	1		E, A, BS, G
97	E48729-009	Plastic Rivet	1		E, A, BS, G
98	QSR0085-001U	Voltage Selector	1		
98	QSR0085-001UBS	Voltage Selector	1		BS
99	E69589-001	Spacer	1		J
100	E50670-003	Wire Clamp	1		
101	E65494-002	Plate	1		E, A, BS, G
102	E66341-002	Plate	1		
103	E69291-001	Fuse Cover	1		
104	QMF51A2-8ROL	Fuse	1		P
104	QMF51A2-4ROS	Fuse	1		U, E, A, G
104	QMF51A2-4ROBS	Fuse	1		BS
105	E3400-355	Felt Space	1		

△ : Safety Parts

(S) and (B) in the Description Column indicate silver and black versions.

2. Exploded View and Part Numbers List

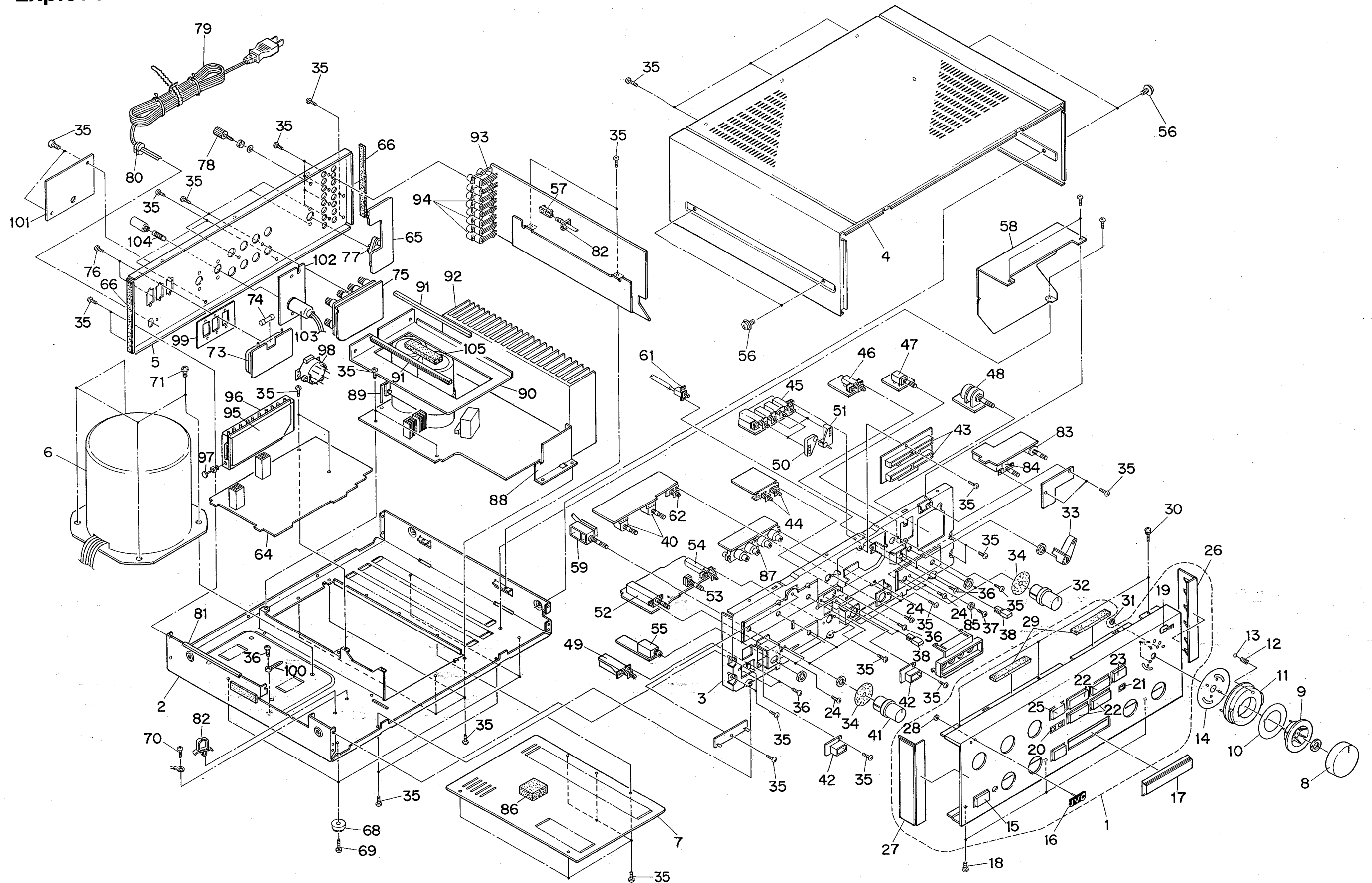

Fig. 1

3. Printed Circuit Board Ass'y and Parts List

3-(1) ENH-006 □ Equalizer P. C. Board Ass'y

Note: ENH-006 □ varies according to the areas employed. See note (1) when placing an order.

Note (1)

Designated Areas	P.C. Board Ass'y
U.S.A., Canada	ENH-006 D
West Germany	ENH-006 C
Europe, Australia U.S. Military Market U.K., Other Countries	ENH-006 B

Note (2)

The symbols (赤、黒、白etc.) on P.C. Board surface are factory process only.

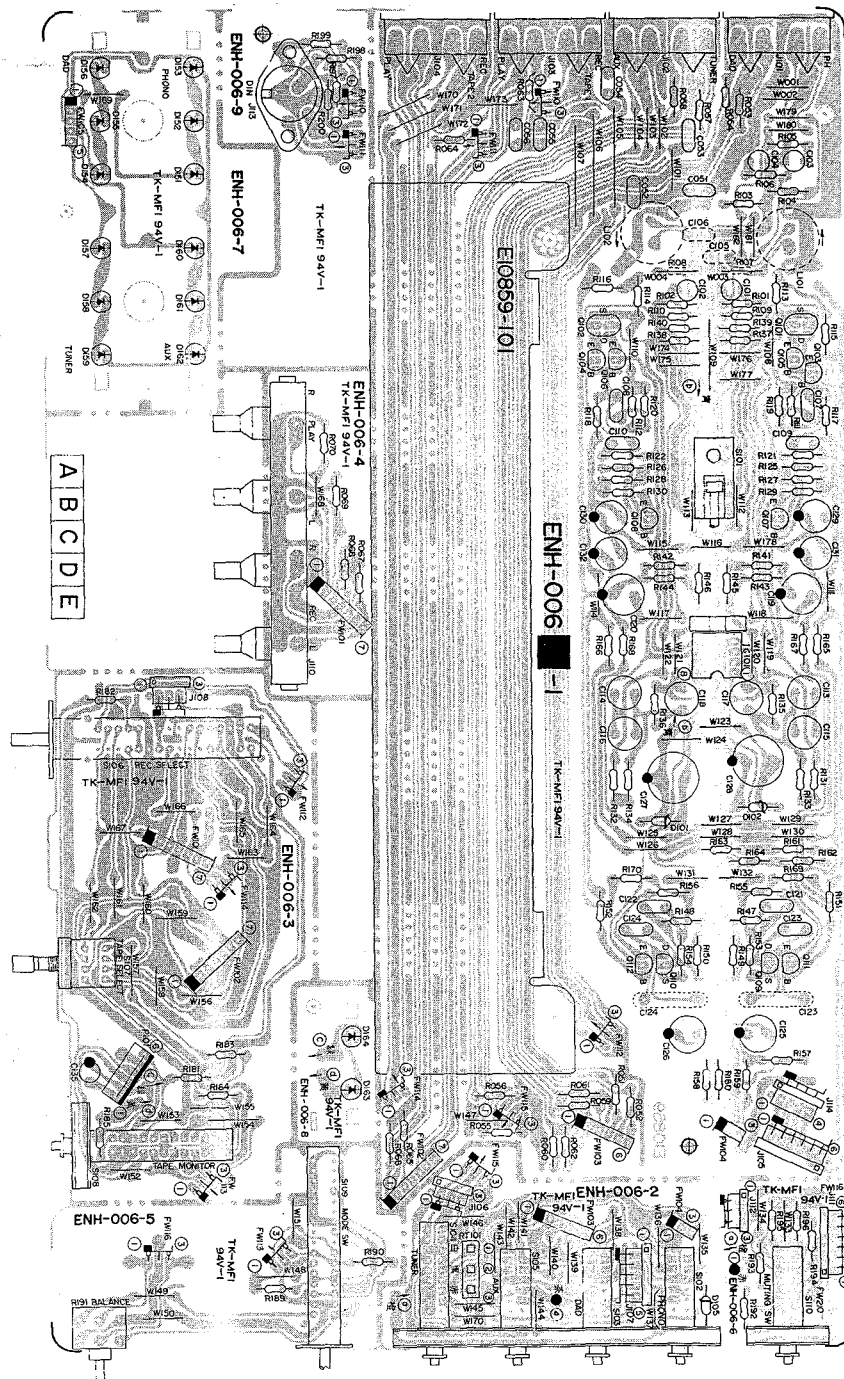
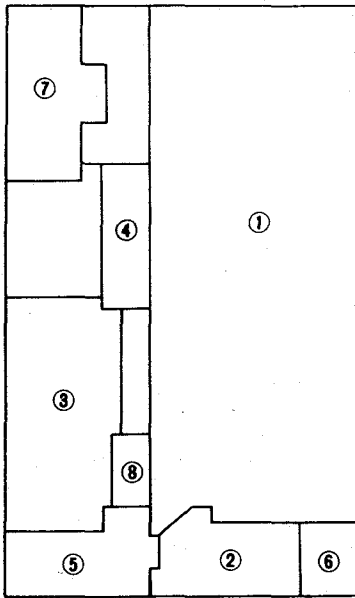

Fig. 2

Each Individual P.C. Board Location



- ① ENH-006-1 Equalizer P. C. Board Ass'y
- ② ENH-006-2 Source Selector P. C. Board Ass'y
- ③ ENH-006-3 Tape Monitor P. C. Board Ass'y
- ④ ENH-006-4 Tape Pin Jack P. C. Board Ass'y
- ⑤ ENH-006-5 Mode Balance P. C. Board Ass'y
- ⑥ ENH-006-6 Muting P. C. Board Ass'y
- ⑦ ENH-006-7 Source Indicator P. C. Board Ass'y
- ⑧ ENH-006-8 Tape Indicator P. C. Board Ass'y
- ⑨ ENH-006-9 DIN Connector P.C. Board Ass'y

Fig. 3

Transistors

Item No.	Part Number	Description	Description		□
			Material	Maker	
Q101	2SK240V (BL, V)	F.E.T.		Toshiba	
Q102	2SK240V (BL, V)	F.E.T.		Toshiba	
Q103	2SC2240 (GR, BL)	Silicon		Toshiba	
Q104	2SC2240 (GR, BL)	Silicon		Toshiba	
Q105	2SC2240 (GR, BL)	Silicon		Toshiba	
Q106	2SC2240 (GR, BL)	Silicon		Toshiba	
Q107	2SA970 (GR, BL)	Silicon		Toshiba	
Q108	2SA970 (GR, BL)	Silicon		Toshiba	
Q109	2SK163 (L1)	F.E.T.		NEC	
Q110	2SK163 (L1)	F.E.T.		NEC	
Q111	2SC1815 (Y, GR)	Silicon		Toshiba	
Q112	2SC1815 (Y, GR)	Silicon		Toshiba	

Diodes

Item No.	Part Number	Description	Description		□
			Material	Maker	
D101	RD20EB3	Zener		NEC	
D102	RD20EB3	Zener		NEC	
D105	RD8.2EB3	Zener		NEC	
D151	SLR-55DC3F	L.E.D		Rohm	
D152	SLR-55DC3F	L.E.D		Rohm	
D153	SLR-55DC3F	L.E.D		Rohm	
D154	SLR-55DC3F	L.E.D		Rohm	
D155	SLR-55DC3F	L.E.D		Rohm	
D156	SLR-55DC3F	L.E.D		Rohm	
D157	SLR-55DC3F	L.E.D		Rohm	
D158	SLR-55DC3F	L.E.D		Rohm	
D159	SLR-55DC3F	L.E.D		Rohm	
D160	SLR-55DC3F	L.E.D		Rohm	
D161	SLR-55DC3F	L.E.D		Rohm	
D162	SLR-55DC3F	L.E.D		Rohm	
D163	SLR-55DC3F	L.E.D		Rohm	
D164	SLR-55DC3F	L.E.D		Rohm	

ICs

Item No.	Part Number	Description	Description		□
			Material	Maker	
IC101	NJM4560D-X			JRC	

△: Safety Parts

The column marked with □ indicates the area.

Parts without character in the column are used commonly regardless of delivery area.

Capacitors

Item No.	Part Number	Description			□
C051	QFV81HJ-154	T. Film	0.15M	50V	
C052	QFV71HJ-103	T. Film	0.01M	50V	
C053	QFV71HJ-103	T. Film	0.01M	50V	
C054	QFV71HJ-103	T. Film	0.01M	50V	
C055	QFV71HJ-103	T. Film	0.01M	50V	
C056	QFV71HJ-103	T. Film	0.01M	50V	
C101	QFS81HJ-471	Poly	470P	50V	
C102	QFS81HJ-471	Poly	470P	50V	
C103	QFS81HJ-101	Poly	100P	50V	D
C104	QFS81HJ-101	Poly	100P	50V	D
C107	QFV81HJ-472	T. Film	4700P	50V	
C108	QFV71HJ-472	T. Film	4700P	50V	
C109	QFV71HJ-102	T. Film	1000P	50V	
C110	QFV71HJ-102	T. Film	1000P	50V	
C113	QFS81HG-822	Poly	8200P	50V	
C114	QFS81HG-822	Poly	8200P	50V	
C115	QFS81HG-822	Poly	8200P	50V	
C116	QFS81HG-822	Poly	8200P	50V	
C117	QFS81HG-472	Poly	4700P	50V	
C118	QFS81HG-472	Poly	4700P	50V	
C119	QET51AM-477	Electro	470M	10V	
C120	QET51AM-477	Electro	470M	10V	
C121	QFV71HJ-272	T. Film	2700P	50V	
C122	QFV71HJ-272	T. Film	2700P	50V	
C123	QFV71HJ-474	T. Film	0.47M	50V	
C124	QFV71HJ-474	T. Film	0.47M	50V	
C125	QET61HM-106	Electro	10M	50V	
C126	QET61HM-106	Electro	10M	50V	
C127	QET51HM-227	Electro	220M	50V	
C128	QET51HM-227	Electro	220M	50V	
C129	QET61EM-107Z	Electro	100M	25V	
C130	QET61EM-107Z	Electro	100M	25V	
C131	QET61EM-107Z	Electro	100M	25V	
C132	QET61EM-107Z	Electro	100M	25V	
C135	QET61AM-476Z	Electro	47M	10V	
C141	QCS21HJ-681	Ceramic	680p	50V	C
C142	QCS21HJ-681	Ceramic	680p	50V	C
C143	QCS21HJ-221	Ceramic	220p	50V	C
C144	QCS21HJ-221	Ceramic	220p	50V	C

Resistors

Item No.	Part Number	Description			□
R051	QRD141J-331S	Carbon	330	1/4W	
R052	QRD141J-331S	Carbon	330	1/4W	
R053	QRD141J-184S	Carbon	180K	1/4W	
R054	QRD141J-184S	Carbon	180K	1/4W	
R055	QRD141J-331S	Carbon	330	1/4W	
R056	QRD141J-331S	Carbon	330	1/4W	
R057	QRD141J-184S	Carbon	180K	1/4W	
R058	QRD141J-184S	Carbon	180K	1/4W	
R059	QRD141J-331S	Carbon	330	1/4W	
R060	QRD141J-331S	Carbon	330	1/4W	
R061	QRD141J-184S	Carbon	180K	1/4W	
R062	QRD141J-184S	Carbon	180K	1/4W	
R063	QRD141J-184S	Carbon	180K	1/4W	
R064	QRD141J-184S	Carbon	180K	1/4W	
R065	QRD141J-184S	Carbon	180K	1/4W	

Item No.	Part Number	Description			□
R066	QRD141J-184S	Carbon	180K	1/4W	
R067	QRD141J-105S	Carbon	1M	1/4W	
R068	QRD141J-105S	Carbon	1M	1/4W	
R069	QRD141J-184S	Carbon	180K	1/4W	
R070	QRD141J-184S	Carbon	180K	1/4W	
R101	QRD141J-101S	Carbon	100	1/4W	
R102	QRD141J-101S	Carbon	100	1/4W	
R103	QRD141J-473S	Carbon	47K	1/4W	
R104	QRD141J-473S	Carbon	47K	1/4W	
R105	QRD141J-471S	Carbon	330	1/4W	D
R106	QRD141J-471S	Carbon	470	1/4W	D
R107	QRD141J-152S	Carbon	1.5K	1/4W	C
R108	QRD141J-152S	Carbon	1.5K	1/4W	C
R109	QRD141J-5R6S	Carbon	5.6	1/4W	
R110	QRD141J-5R6S	Carbon	5.6	1/4W	
R111	QRD148J-153S	Carbon	15K	1/4W	
R112	QRD141J-153S	Carbon	15K	1/4W	
R113	QRD141J-222S	Carbon	2.2K	1/4W	
R114	QRD141J-222S	Carbon	2.2K	1/4W	
R115	QRD148J-272S	Carbon	2.7K	1/4W	
R116	QRD141J-272S	Carbon	2.7K	1/4W	
R117	QRD148J-683S	Carbon	68K	1/4W	
R118	QRD141J-683S	Carbon	68K	1/4W	
R119	QRD141J-331S	Carbon	330	1/4W	
R120	QRD141J-331S	Carbon	330	1/4W	
R121	QRD141J-121S	Carbon	120	1/4W	
R122	QRD141J-121S	Carbon	120	1/4W	
R125	QRD141J-102S	Carbon	1K	1/4W	
R126	QRD141J-102S	Carbon	1K	1/4W	
R127	QRD141J-621S	Carbon	620	1/4W	
R128	QRD141J-621S	Carbon	620	1/4W	
R129	QRD141J-621S	Carbon	620	1/4W	
R130	QRD141J-621S	Carbon	620K	1/4W	
R131	QRD141J-184S	Carbon	180K	1/4W	
R132	QRD141J-184S	Carbon	180K	1/4W	
R133	QRD141J-822S	Carbon	8.2K	1/4W	
R134	QRD141J-822S	Carbon	8.2K	1/4W	
R135	QRD141J-163S	Carbon	16K	1/4W	
R136	QRD141J-163S	Carbon	16K	1/4W	
R137	QRD141J-271S	Carbon	270	1/4W	
R138	QRD141J-271S	Carbon	270	1/4W	
R139	QRD141J-220S	Carbon	22	1/4W	
R140	QRD141J-220S	Carbon	22	1/4W	
R141	QRD141J-392S	Carbon	3.9K	1/4W	
R142	QRD141J-392S	Carbon	3.9K	1/4W	
R143	QRD141J-133S	Carbon	13K	1/4W	
R144	QRD141J-133S	Carbon	13K	1/4W	
R145	QRD141J-155S	Carbon	1.5M	1/4W	
R146	QRD141J-155S	Carbon	1.5M	1/4W	
R147	QRD141J-564S	Carbon	560	1/4W	
R148	QRD141J-564S	Carbon	560K	1/4W	
R149	QRD148J-475S	Carbon	4.7M	1/4W	
R150	QRD148J-475S	Carbon	4.7M	1/4W	
R151	QRD141J-433S	Carbon	43K	1/4W	
R152	QRD141J-433S	Carbon	43K	1/4W	
R153	QRD141J-182S	Carbon	1.8K	1/4W	
R154	QRD141J-182S	Carbon	1.8K	1/4W	
R155	QRD141J-822S	Carbon	8.2K	1/4W	
R156	QRD141J-822S	Carbon	8.2K	1/4W	
R157	QRD141J-224S	Carbon	220K	1/4W	

△: Safety Parts

The column marked with □ indicates the area.

Parts without character in the column are used commonly regardless of delivery area.

Resistors

Item No.	Part Number	Description	<input type="checkbox"/>
R158	QRD141J-224S	Carbon 220K 1/4W	
R159	QRD141J-331S	Carbon 330 1/4W	
R160	QRD141J-331S	Carbon 330 1/4W	
R161 Δ	QRD145J-122S	UNF. Carbon 1.2K 1/4W	
R162 Δ	QRD145J-122S	UNF. Carbon 1.2K 1/4W	
R163 Δ	QRD145J-122S	UNF. Carbon 1.2K 1/4W	
R164 Δ	QRD145J-122S	UNF. Carbon 1.2K 1/4W	
R165	QRD141J-392S	Carbon 3.9K 1/4W	
R166	QRD141J-392S	Carbon 3.9K 1/4W	
R167	QRD141J-392S	Carbon 3.9K 1/4W	
R168	QRD141J-392S	Carbon 3.9K 1/4W	
R169	QRD141J-183S	Carbon 18K 1/4W	
R170	QRD141J-183S	Carbon 18K 1/4W	
R181	QRD141J-331S	Carbon 330 1/4W	
R182	QRD141J-331S	Carbon 330 1/4W	
R183	QRD141J-331S	Carbon 330 1/4W	
R184	QRD141J-331S	Carbon 330 1/4W	
R185	QRD141J-121S	Carbon 120 1/4W	
R189	QRD141J-472S	Carbon 4.7K 1/4W	
R190	QRD141J-472S	Carbon 4.7K 1/4W	
R191	QVD7A7M-1F5V	Variable	
R192	QRD141J-680S	Carbon 68 1/4W	
R193	QRD141J-823S	Carbon 82K 1/4W	
R194	QRD141J-823S	Carbon 82K 1/4W	
R195	QRD141J-103S	Carbon 10K 1/4W	
R196	QRD141J-103S	Carbon 10K 1/4W	
R197	QRD141J-334S	Carbon 330K 1/4W	C, D
R198	QRD141J-334S	Carbon 330K 1/4W	C, D
R199	QRD141J-104S	Carbon 100K 1/4W	C, D
R200	QRD141J-104S	Carbon 100K 1/4W	C, D

Others

Item No.	Part Number	Description	<input type="checkbox"/>
	E43727-002	Tab	
	E43727-002	Tab	
	E10859-101	Circuit Board	
	E302099-001	Shield Bracket	
	QHW4110-001	Wire Clamp	
	E302805-001	LED Holder	
	E70535-001	LED Holder	
	E33754-001	Tie Band	
	SBSB3008Z	Screw	
	E03532-001	Shield Case	C
J101	EMN00TV-403A	Pin Jack Ass'y	
J102	EMN00TV-402A	Pin Jack Ass'y	
J103	EMN00TV-402A	Pin Jack Ass'y	
J104	EMN00TV-402A	Pin Jack Ass'y	
J105	E04365-006	6P Connector	
J106	E04365-003	3P Socket	
J107	E04365-005	F.W. Socket	
J108	E04365-003	3P Socket	
J110	EMN00YV-403A	Pin Jack Ass'y	
J111	E04365-006	6P Connector	
J112	E04365-003	3P Socket	
J113	E03623-003	DIN Socket	C
J114	E04365-004	Jumper Socket	
P101	QMV5005-006	6P Plug Ass'y	
S101	QSS4201-504	Slide Switch	
S102	QST5462-E01	Push Switch	
S103	QST5462-E01	Push Switch	
S104	QST5462-E01	Push Switch	
S105	QST5462-E01	Push Switch	
S106	QSR6346-252	Rotary Switch	
S107	QSR6223-252	Rotary Switch	
S108	QST5102-E04	Push Switch	
S109	QSR6345-252	Rotary Switch	
S110	QST5102-E03	Push Switch	
RT101	E67764-003	Terminal	

Coils

Item No.	Part Number	Description	<input type="checkbox"/>
L101	EQL0111-151	Inductor	C
L102	EQL0111-151	Inductor	C

Δ : Safety Parts

The column marked with indicates the area.

Parts without character in the column are used commonly regardless of delivery area.

3-(2) ENH-007B Gm Volume Driver P. C. Board Ass'y

Note: The symbols (赤、黒、白etc.) on P.C. Board surface are factory process only.

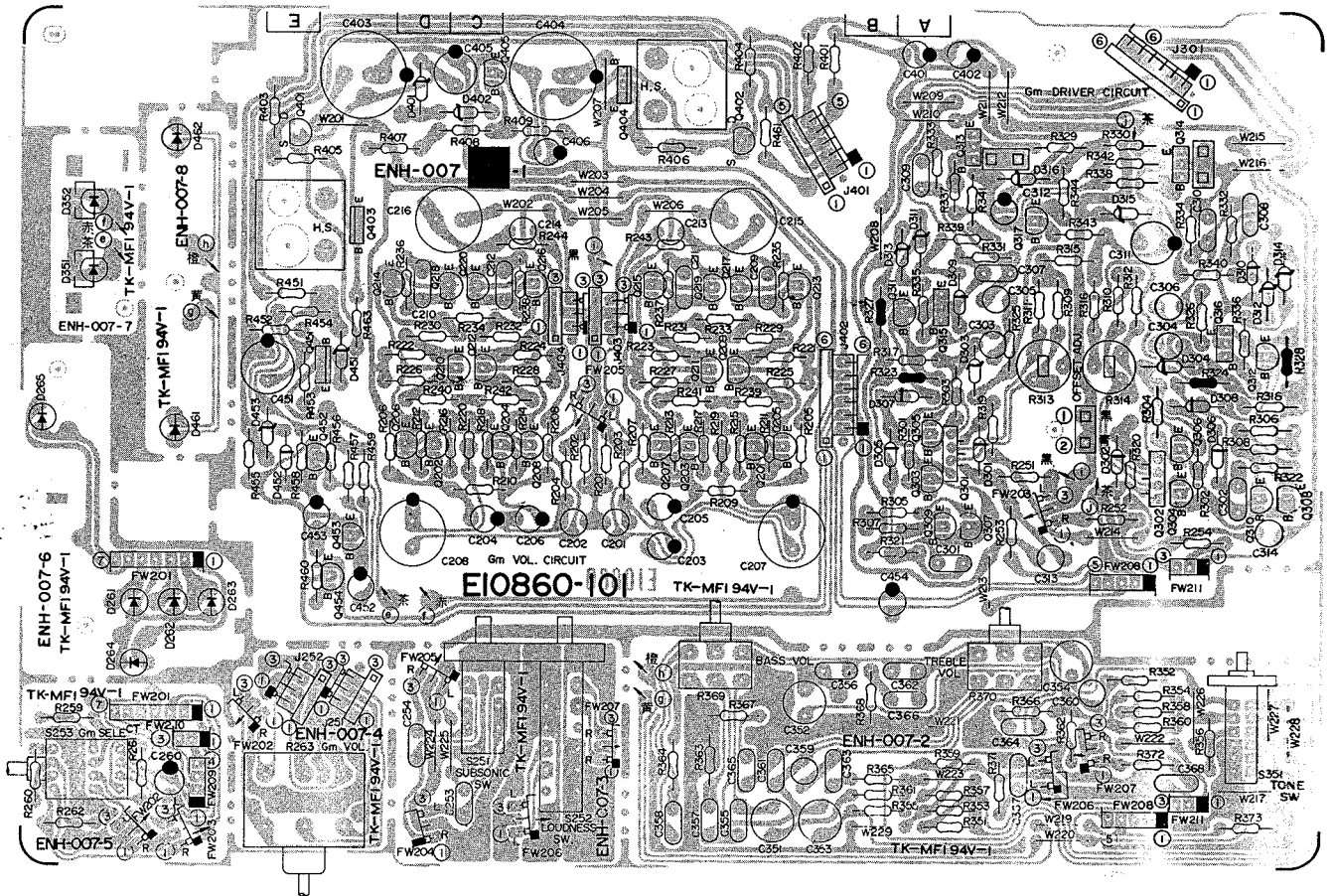

Fig. 4

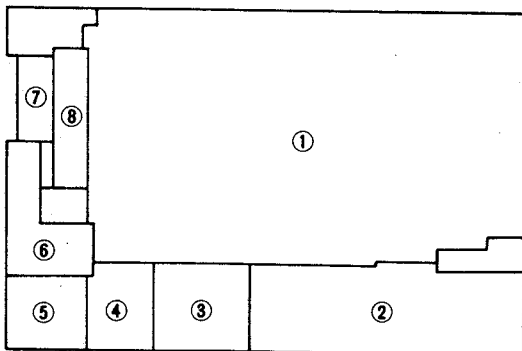

Fig. 5

- ① ENH-007-1 Gm Volume Driver P.C. Board Ass'y
- ② ENH-007-2 Tone P.C. Board Ass'y
- ③ ENH-007-3 Loudness and Subsonic P.C. Board Ass'y
- ④ ENH-007-4 Gm Volume P.C. Board Ass'y
- ⑤ ENH-007-5 Gm Selector P.C. Board Ass'y
- ⑥ ENH-007-6 Muting, Gm Selector and Point Indicator P.C. Board Ass'y
- ⑦ ENH-007-7 Power Indicator P.C. Board Ass'y
- ⑧ ENH-007-8 Tone Indicator P.C. Board Ass'y

Transistors

Item No.	Part Number	Description		□
			Maker	
Q201	2SC1775AV (E, F)	Silicon	Hitachi	
Q202	2SC1775AV (E, F)	Silicon	Hitachi	
Q203	2SA872AV (E, F)	Silicon	Hitachi	
Q204	2SA872AV (E, F)	Silicon	Hitachi	
Q205	2SA970 (GR, BL)	Silicon	Toshiba	
Q206	2SA970 (GR, BL)	Silicon	Toshiba	
Q207	2SC2240 (GR, BL)	Silicon	Toshiba	
Q208	2SC2240 (GR, BL)	Silicon	Toshiba	
Q209	2SA1084 (D, E)	Silicon	Hitachi	
Q210	2SA1084 (D, E)	Silicon	Hitachi	
Q211	2SC2546 (E, F)	Silicon	Hitachi	
Q212	2SC2546 (E, F)	Silicon	Hitachi	
Q213	2SA872AV (E, F)	Silicon	Hitachi	
Q214	2SA872AV (E, F)	Silicon	Hitachi	
Q215	2SC1775AV (E, F)	Silicon	Hitachi	
Q216	2SC1775AV (E, F)	Silicon	Hitachi	
Q217	2SC2240 (GR, BL)	Silicon	Toshiba	
Q218	2SC2240 (GR, BL)	Silicon	Toshiba	
Q219	2SA970 (GR, BL)	Silicon	Toshiba	
Q220	2SA970 (GR, BL)	Silicon	Toshiba	
Q301	2SK389 (BL, V)	F.E.T.	Toshiba	
Q302	2SK389 (BL, V)	F.E.T.	Toshiba	
Q303	2SC2240 (GR, BL)	Silicon	Toshiba	
Q304	2SC2249 (GR, BL)	Silicon	Toshiba	
Q305	2SC2240 (GR, BL)	Silicon	Toshiba	
Q306	2SC2240 (GR, BL)	Silicon	Toshiba	
Q307	2SA1029 (C, D)	Silicon	Hitachi	
Q308	2SA1029 (C, D)	Silicon	Hitachi	
Q309	2SA1029 (C, D)	Silicon	Hitachi	
Q310	2SA1029 (C, D)	Silicon	Hitachi	
Q311	2SA1029 (C, D)	Silicon	Hitachi	
Q312	2SA1029 (C, D)	Silicon	Hitachi	
Q313	2SC2912 (S, T)	Silicon	Sanyo	
Q314	2SC2912 (S, T)	Silicon	Sanyo	
Q315	2SA1210 (S, T)	Silicon	Sanyo	
Q316	2SA1210 (S, T)	Silicon	Sanyo	
Q317	2SC2235 (O, Y)	Silicon	Toshiba	
Q401	2SK246 (Y)	F.E.T.	Toshiba	
Q402	2SK246 (Y)	F.E.T.	Toshiba	
Q403	2SD313V (E)	Silicon	Sanyo	
Q404	2SB507V (E)	Silicon	Sanyo	
Q405	2SA872AV (E, F)	Silicon	Hitachi	
Q451	2SB507V (E)	Silicon	Sanyo	
Q452	2SC1815 (Y, GR)	Silicon	Toshiba	
Q453	2SC1815 (Y, GR)	Silicon	Toshiba	
Q454	2SC1815 (Y, GR)	Silicon	Toshiba	

Diodes

Item No.	Part Number	Description		□
			Maker	
D261	SLR-34DC50F	L.E.D.	Rohm	
D262	SLR-34DC50F	L.E.D.	Rohm	
D263	SLR-34DC50F	L.E.D.	Rohm	
D264	SLR-34DC50F	L.E.D.	Rohm	
D265	SLR-34DC50F	L.E.D.	Rohm	

Item No.	Part Number	Description		□
			Maker	
D301	1S2076-31	Silicon	Hitachi	
D302	1S2076-31	Silicon	Hitachi	
D303	RD5.6EB3	Zener	NEC	
D304	RD5.6EB3	Zener	NEC	
D305	1S2076-31	Silicon	Hitachi	
D306	1S2076-31	Silicon	Hitachi	
D307	1S2076-31	Silicon	Hitachi	
D308	1S2076-31	Silicon	Hitachi	
D309	1SS81	Silicon	Hitachi	
D310	1SS81	Silicon	Hitachi	
D311	RD2.7EB2	Zener	NEC	
D312	RD2.7EB2	Zener	NEC	
D313	RD2.7EB2	Zener	NEC	
D314	RD2.7EB2	Zener	NEC	
D315	RD20EB3	Zener	NEC	
D316	RD2.7EB2	Zener	NEC	
D351	SLR-55DC3F	L.E.D.	Rohm	
D352	SLR-55DC3F	L.E.D.	Rohm	
D401	RD22EB3	Zener	NEC	
D402	RD20EB3	Zener	NEC	
D451	RD5.6EB2	Zener	NEC	
D452	1S2076-31	Silicon	Hitachi	
D453	RD8.2EB3	Zener	NEC	
D461	SLR-34DC50F	L.E.D.	Rohm	
D462	SLR-34DC50F	L.E.D.	Rohm	

Capacitors

Item No.	Part Number	Description			□
C201	QFS81HJ-101	Poly	100P	50V	
C202	QFS81HJ-101	Poly	100P	50V	
C203	QET51HM-105	Electro	1M	50V	
C204	QET61HM-105	Electro	1M	50V	
C205	QET61HM-105	Electro	1M	50V	
C206	QET61HM-105	Electro	1M	50V	
C207	QET51HM-227	Electro	220M	50V	
C208	QET51HM-227	Electro	220M	50V	
C209	QFV71HJ-332	T. Film	3300P	50V	
C210	QFV71HJ-332	T. Film	3300P	50V	
C211	QFV71HJ-332	T. Film	3300P	50V	
C212	QFV71HJ-332	T. Film	3300P	50V	
C213	QFS81HJ-101	Poly	100P	50V	
C214	QFS81HJ-101	Poly	100P	50V	
C215	QEN51HM-106E	Non Pole	10M	50V	
C216	QEN51HM-106E	Non Pole	10M	50V	
C253	QFV71HJ-823	T. Film	0.082M	50V	
C254	QEV71HJ-823	T. Film	0.082M	50V	
C260	QET61AM-476	Electro	47M	10V	
C301	QFV71HJ-222	T. Film	2200P	50V	
C302	QFV71HJ-222	T. Film	2200P	50V	
C303	QFS82BJ-390	Poly	39P	125V	
C304	QFS82BJ-390	Poly	39P	125V	
C305	QFS82BJ-680	Poly	68P	125V	
C306	QFS82BJ-680	Poly	68P	125V	
C307	QFV71HJ-222	T. Film	2200P	50V	
C308	QFV71HJ-222	T. Film	2200P	50V	
C309	QFV71HJ-222	T. Film	2200P	50V	
C310	QFV71HJ-222	T. Film	2200P	50V	
C311	QET61HM-476	Electro	47M	50V	

△: Safety Parts

The column marked with □ indicates the area.

Parts without character in the column are used commonly regardless of delivery area.

Capacitors

Item No.	Part Number	Description	□
C312	QET61HM-105	Electro 1M 50V	
C313	QFS82BJ-5R0	Poly 5.0P 125V	
C314	QFS82BJ-5R0	Poly 5.0P 125V	
C351	QEN61HM-475	Non Pole 4.7M 50V	
C352	QEN61HM-475	Non Pole 4.7M 50V	
C353	QEN61HM-475	Non Pole 4.7M 50V	
C354	QEN51HM-475	Non Pole 4.7M 50V	
C355	QFV71HJ-153	T. Film 0.015M 50V	
C356	QFV71HJ-153	T. Film 0.015M 50V	
C357	QFV71HJ-823	T. Film 0.082M 50V	
C358	QFV71HJ-823	T. Film 0.082M 50V	
C359	QFS81HJ-221	Poly 220P 50V	
C360	QFS81HJ-221	Poly 220P 50V	
C361	QFV71HJ-122	T. Film 1200P 50V	
C362	QFV71HJ-122	T. Film 1200P 50V	
C363	QFV71HJ-332	T. Film 3300P 50V	
C364	QFV71HJ-332	T. Film 3300P 50V	
C365	QFV71HJ-183	T. Film 0.018M 50V	
C366	QFV71HJ-183	T. Film 0.018M 50V	
C367	QFV71HJ-473	T. Film 4.047M 50V	
C368	QFV71HJ-473	T. Film 0.047M 50V	
C401	QET52AM-225	Electro 2.2M 100V	
C402	QET52AM-225	Electro 2.2M 100V	
C403	QET51HM-107E	Electro 100M 50V	
C404	QET51HM-107E	Electro 100M 50V	
C405	QET61HM-476	Electro 47M 50V	
C406	QET61HJ-106	Electro 10M 50V	
C451	QET51JM-107	Electro 100M 63V	
C452	QET61HM-225	Electro 100M 50V	
C453	QET61HM-225	Electro 2.2 50V	
C454	QET61AM-476	Electro 47M 10V	

Resistors

Item No.	Part Number	Description	□
R201	QRD141J-474S	Carbon 470K 1/4W	
R202	QRD141J-474S	Carbon 470K 1/4W	
R203	QRD141J-151S	Carbon 150 1/4W	
R204	QRD141J-151S	Carbon 150 1/4W	
R205	QRD141J-224S	Carbon 220K 1/4W	
R206	QRD141J-224S	Carbon 220K 1/4W	
R207	QRD141J-224S	Carbon 220K 1/4W	
R208	QRD141J-224S	Carbon 220K 1/4W	
R209	QRD141J-153S	Carbon 15K 1/4W	
R210	QRD141J-153S	Carbon 15K 1/4W	
R211	QRD141J-821S	Carbon 820 1/4W	
R212	QRD141J-821S	Carbon 820 1/4W	
R213	QRD141J-821S	Carbon 820 1/4W	
R214	QRD141J-821S	Carbon 820 1/4W	
R215	QRD141J-151S	Carbon 150 1/4W	
R216	QRD141J-151S	Carbon 150 1/4W	
R217	QRD141J-151S	Carbon 150 1/4W	
R218	QRD141J-151S	Carbon 150 1/4W	
R219	QRD141J-241S	Carbon 240 1/4W	
R220	QRD141J-241S	Carbon 240K 1/4W	
R221	QRD141J-102S	Carbon 1K 1/4W	
R222	QRD141J-102S	Carbon 1K 1/4W	
R223	QRD141J-102S	Carbon 1K 1/4W	

Item No.	Part Number	Description	□
R224	QRD141J-102S	Carbon 1K 1/4W	
R225	QRD141J-182S	Carbon 1.8K 1/4W	
R226	QRD141J-182S	Carbon 1.8K 1/4W	
R227	QRD141J-182S	Carbon 1.8K 1/4W	
R228	QRD141J-182S	Carbon 1.8K 1/4W	
R229	QRD141J-272S	Carbon 2.7K 1/4W	
R230	QRD141J-272S	Carbon 2.7K 1/4W	
R231	QRD141J-272S	Carbon 2.7K 1/4W	
R232	QRD141J-272S	Carbon 2.7K 1/4W	
R233	QRD141J-823S	Carbon 82K 1/4W	
R234	QRD141J-823S	Carbon 82K 1/4W	
R235	QRD141J-821S	Carbon 820 1/4W	
R236	QRD141J-821S	Carbon 820 1/4W	
R237	QRD141J-821S	Carbon 820 1/4W	
R238	QRD141J-821S	Carbon 820 1/4W	
R239	QRD141J-562S	Carbon 5.6K 1/4W	
R240	QRD141J-562S	Carbon 5.6K 1/4W	
R241	QRD141J-562S	Carbon 5.6K 1/4W	
R242	QRD141J-562S	Carbon 5.6K 1/4W	
R243	QRD141J-223S	Carbon 22K 1/4W	
R244	QRD141J-223S	Carbon 22K 1/4W	
R251	QRD141J-123S	Carbon 12K 1/4W	
R252	QRD141J-123S	Carbon 12K 1/4W	
R253	QRD141J-243S	Carbon 24K 1/4W	
R254	QRD141J-243S	Carbon 24K 1/4W	
R259	QRD141J-393S	Carbon 39K 1/4W	
R260	QRD141J-393S	Carbon 39K 1/4W	
R261	QRD141J-183S	Carbon 18K 1/4W	
R262	QRD141J-183S	Carbon 18K 1/4W	
R263	QVZ1224-001	Variable	
R301	△ QRZ0062-561	Fusible 560 1/4W	
R302	△ QRZ0062-561	Fusible 560 1/4W	
R303	△ QRZ0062-561	Fusible 560 1/4W	
R304	△ QRZ0062-561	Fusible 560 1/4W	
R305	△ QRD145J-331S	UNF Carbon 330 1/4W	
R306	△ QRD145J-331S	UNF Carbon 330 1/4W	
R307	△ QRD145J-331S	UNF Carbon 330 1/4W	
R308	△ QRD145J-331S	UNF Carbon 330 1/4W	
R309	QRD141J-220S	Carbon 22 1/4W	
R310	QRD141J-220S	Carbon 22 1/4W	
R311	QRD141J-220S	Carbon 22 1/4W	
R312	QRD141J-220S	Carbon 22 1/4W	
R313	QVP4A0B-101	Variable	
R314	QVP4A0B-101	Variable	
R315	QRD141J-752S	Carbon 7.5K 1/4W	
R316	QRD141J-752S	Carbon 7.5K 1/4W	
R317	QRD141J-473S	Carbon 47K 1/4W	
R318	QRD141J-473S	Carbon 47K 1/4W	
R319	△ QRZ0062-331	Fusible 330 1/4W	
R320	△ QRZ0062-331	Fusible 330 1/4W	
R321	△ QRD145J-271S	UNF Carbon 270 1/4W	
R322	△ QRD145J-271S	UNF Carbon 270 1/4W	
R323	△ QRZ0062-102	Fusible 1K 1/4W	
R324	△ QRZ0062-102	Fusible 1K 1/4W	
R325	QRD141J-332S	Carbon 3.3K 1/4W	
R326	QRD141J-332S	Carbon 3.3K 1/4W	
R327	△ QRZ0062-680	Fusible 68 1/4W	
R328	△ QRZ0062-680	Fusible 68 1/4W	
R329	△ QRD145J-151S	UNF Carbon 150 1/4W	
R330	△ QRD145J-151S	UNF Carbon 150 1/4W	

△ : Safety Parts

The column marked with □ indicates the area.

Parts without character in the column are used commonly regardless of delivery area.

Resistors

Item No.	Part Number	Description	□
R331	QRD141J-562S	Carbon 5.6K 1/4W	
R332	QRD141J-562S	Carbon 5.6K 1/4W	
R333	QRD141J-562S	Carbon 5.6K 1/4W	
R334	QRD141J-562S	Carbon 5.6K 1/4W	
R335	△ QRD145J-821S	UNF. Carbon 820 1/4W	
R336	△ QRD145J-821S	UNF. Carbon 820 1/4W	
R337	△ QRD145J-101S	UNF. Carbon 100 1/4W	
R338	△ QRD145J-101S	UNF. Carbon 100 1/4W	
R339	QRD141J-563S	Carbon 56K 1/4W	
R340	QRD141J-563S	Carbon 56K 1/4W	
R341	QRD141J-563S	Carbon 56K 1/4W	
R342	QRD141J-562S	Carbon 56K 1/4W	
R343	△ QRD145J-152S	UNF. Carbon 1.5K 1/4W	
R344	△ QRD145J-181S	UNF. Carbon 180 1/4W	
R351	QRD141J-473S	Carbon 47K 1/4W	
R352	QRD141J-473S	Carbon 47K 1/4W	
R353	QRD141J-822S	Carbon 8.2K 1/4W	
R354	QRD141J-822S	Carbon 8.2K 1/4W	
R355	QRD148J-225S	Carbon 2.2M 1/4W	
R356	QRD148J-225S	Carbon 2.2M 1/4W	
R357	QRD141J-913S	Carbon 91K 1/4W	
R358	QRD141J-913S	Carbon 91K 1/4W	
R359	QRD141J-104S	Carbon 100K 1/4W	
R360	QRD141J-104S	Carbon 100K 1/4W	
R361	QRD141J-223S	Carbon 22K 1/4W	
R362	QRD141J-223S	Carbon 22K 1/4W	
R363	QRD141J-392S	Carbon 3.9K 1/4W	
R364	QRD141J-392S	Carbon 3.9K 1/4W	
R365	QRD141J-562S	Carbon 5.6K 1/4W	
R366	QRD141J-562S	Carbon 5.6K 1/4W	
R367	QRD141J-102S	Carbon 1K 1/4W	
R368	QRD141J-102S	Carbon 1K 1/4W	
R369	QVZ1709-011	Variable	
R370	QVZ1709-011	Variable	
R371	QRD141J-303S	Carbon 30K 1/4W	
R372	QRD141J-303S	Carbon 30K 1/4W	
R373	QRD141J-121S	Carbon 120K 1/4W	
R401	△ QRD145J-2R2S	UNF. Carbon 2.2 1/4W	
R402	△ QRD145J-2R2S	UNF. Carbon 2.2 1/4W	
R403	△ QRZ0062-330	Fusible 33 1/4W	
R404	△ QRZ0062-330	Fusible 33 1/4W	
R405	△ QRD145J-220S	UNF. Carbon 22 1/4W	
R406	△ QRD145J-220S	UNF. Carbon 22 1/4W	
R407	QRD141J-273S	Carbon 27K 1/4W	
R408	QRD141J-822S	Carbon 8.2K 1/4W	
R409	QRD141J-333S	Carbon 33K 1/4W	
R452	QRD141J-683S	Carbon 68K 1/4W	
R453	QRD141J-271S	Carbon 270 1/4W	
R454	QRD141J-822S	Carbon 8.2K 1/4W	
R455	QRD141J-101S	Carbon 100 1/4W	
R456	QRD141J-472S	Carbon 4.7K 1/4W	
R457	QRD141J-472S	Carbon 4.7K 1/4W	
R458	QRD141J-224S	Carbon 220K 1/4W	
R459	QRD141J-224S	Carbon 220K 1/4W	
R460	QRD141J-153S	Carbon 15K 1/4W	
R461	△ QRZ0062-680	Fusible 68 1/4W	
R463	△ QRD145J-471S	UNF. Carbon 470 1/4W	

Others

Item No.	Part Number	Description	□
	E67764-002	Terminal Ass'y	
	E10860-101	Circuit Board	
	E70535-001	LED Holder	
	E33754-001	Tie Band	
	SBSB3008CC	Screw	
J251	E70945-H25	Heat Sink	
J252	E04365-003	3P Socket	
J301	E04365-006	6P Connector	
J401	E04365-005	F.W. Socket	
J402	E04365-006	6P Socket	
J403	E04365-003	3P Socket	
J404	E04365-003	3P Socket	
S251	QST2241-E02	Push Switch	
S252	QST2241-E02	Push Switch	
S253	QSR6223-201	Rotary Switch	
S351	QST5101-E02	Push Switch	

△: Safety Parts

The column marked with □ indicates the area.

Parts without character in the column are used commonly regardless of delivery area.

3-(3) ENH-008 □ Power Amplifier P. C. Board Ass'y

Note: The symbols (赤、黒、白etc.) on P.C. Board surface are factory process only.

Designated Areas	P.C. Board Ass'y
West Germany	ENH-008 C
All other Countries	ENH-008 B

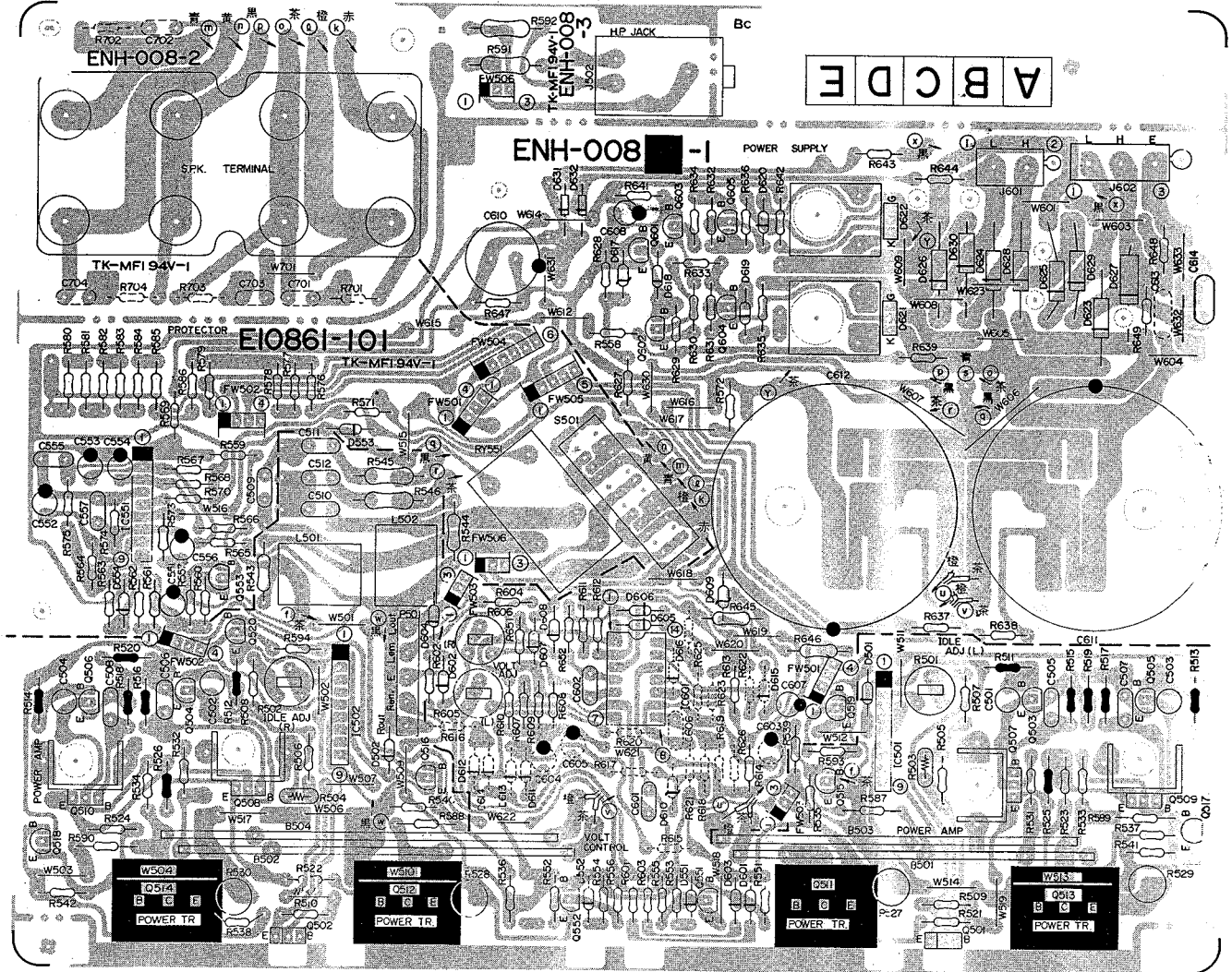

Fig. 6

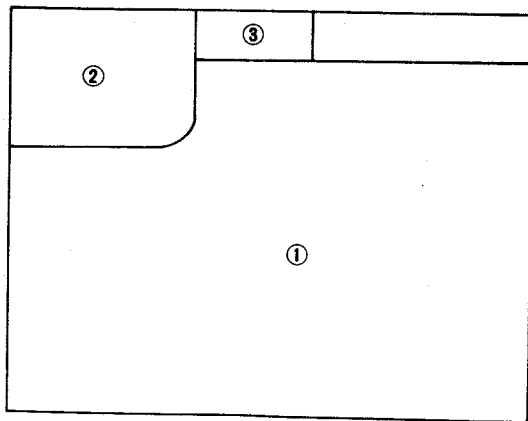

Fig. 7

- ① ENH-008-1 Power Protector P.C. Board Ass'y
- ② ENH-008-2 Speaker P.C. Board Ass'y
- ③ ENH-008-3 Headphone P.C. Board Ass'y

Transistors

Item No.	Part Number	Description	Description		□
			Maker		
Q501	2SD636 (Q, R)	Silicon	Hitachi		
Q502	2SD636 (Q, R)	Silicon	Matsushita		
Q503	2SC2909 (S, T)	Silicon	Sanyo		
Q504	2SC2909 (S, T)	Silicon	Sanyo		
Q505	2SA1207 (S, T)	Silicon	Sanyo		
Q506	2SA1207 (S, T)	Silicon	Sanyo		
Q507	2SD669A (B, C)	Silicon	Hitachi		
Q508	2SD669A (B, C)	Silicon	Hitachi		
Q509	2SB649A (B, C)	Silicon	Hitachi		
Q510	2SB649A (B, C)	Silicon	Hitachi		
Q511	2SC2921LF (O, Y)	Silicon	Sanken		
Q512	2SC2921LF (O, Y)	Silicon	Sanken		
Q513	2SA1215LF (O, Y)	Silicon	Sanken		
Q514	2SA1215LF (O, Y)	Silicon	Sanken		
Q515	2SC1815 (Y)	Silicon	Toshiba		
Q516	2SC1815 (Y)	Silicon	Toshiba		
Q517	2SA1015 (Y)	Silicon	Toshiba		
Q518	2SA1015 (Y)	Silicon	Toshiba		
Q519	2SC1815 (Y)	Silicon	Toshiba		
Q520	2SC1815 (Y)	Silicon	Toshiba		
Q551	2SC2909 (S, T)	Silicon	Sanyo		
Q552	2SC2909 (S, T)	Silicon	Sanyo		
Q553	2SA970 (GR, BL)	Silicon	Toshiba		
Q601	2SC1815 (Y, GR)	Silicon	Toshiba		
Q602	2SC2240 (GR, BL)	Silicon	Toshiba		
Q603	2SA970 (GR, BL)	Silicon	Toshiba		
Q604	2SA970 (GR, BL)	Silicon	Toshiba		
Q605	2SC2240 (GR, BL)	Silicon	Toshiba		

ICs

Item No.	Part Number	Description	Description		□
			Maker		
IC501	VC5022-2		Sanyo		
IC502	VC5022-2		Sanyo		
IC551	TA7317P		Toshiba		
IC601	AN6912		Matsushita		

Diodes

Item No.	Part Number	Description	Description		□
			Maker		
D501	1S2076-31	Silicon	Hitachi		
D502	1S2076-31	Silicon	Hitachi		
D551	1S2076-31	Silicon	Hitachi		
D552	1S2076-31	Silicon	Hitachi		
D553	1S2076-31	Silicon	Hitachi		
D554	RD5.6EB3	Zener	NEC		
D601	1S2076-31	Silicon	Hitachi		
D602	1S2076-31	Silicon	Hitachi		
D603	1S2076-31	Silicon	Hitachi		
D604	1S2076-31	Silicon	Hitachi		
D605	1S2076-31	Silicon	Hitachi		
D606	1S2076-31	Silicon	Hitachi		
D607	1S2076-31	Silicon	Hitachi		

Item No.	Part Number	Description	Description		□
			Maker		
D608	1S2076-31	Silicon	Hitachi		
D609	RD15EB3	Zener	NEC		
D610	RD10EB3	Zener	NEC		
D611	1S2076-31	Silicon	Hitachi		
D612	1S2076-31	Silicon	Hitachi		
D613	1S2076-31	Silicon	Hitachi		
D614	1S2076-31	Silicon	Hitachi		
D615	1S2076-31	Silicon	Hitachi		
D616	1S2076-31	Silicon	Hitachi		
D617	RD6.2EB3	Zener	NEC		
D618	RD2.7EB2	Zener	NEC		
D619	1S2076-31	Silicon	Hitachi		
D620	1S2076-31	Silicon	Hitachi		
D621	SF8D41		Toshiba		
D622	SF8D41		Toshiba		
D623	△ 30DL2FC	Silicon	Nippon Inter		
D624	△ 30DL2FC	Silicon	Nippon Inter		
D625	△ 30DL2FC	Silicon	Nippon Inter		
D626	△ 30DL2FC	Silicon	Nippon Inter		
D627	△ 30DL2FC	Silicon	Nippon Inter		
D628	△ 30DL2FC	Silicon	Nippon Inter		
D629	△ 30DL2FC	Silicon	Nippon Inter		
D630	△ 30DL2FC	Silicon	Nippon Inter		
D631	△ ERB12-02RKL1	Silicon	Fujidenki		
D632	△ ERB12-02RKL1	Silicon	Fujidenki		

Capacitors

Item No.	Part Number	Description		□
C501	QFS82BJ-220	Poly	22	
C502	QFS82BJ-220	Poly	22	
C503	QFS82BJ-220	Poly	22	
C504	QFS82BJ-220	Poly	22	
C505	QFV71HJ-102	T. Film	0.001M 50V	
C506	QFV71HJ-102	T. Film	0.001M 50V	
C507	QFV71HJ-102	T. Film	0.001M 50V	
C508	QFV71HJ-102	T. Film	0.001M 50V	
C509	QFV71HJ-104	T. Film	0.1M 50V	
C510	QFV71HJ-104	T. Film	0.1M 50V	
C511	QFV71HJ-104	T. Film	0.1M 50V	
C512	QFV71HJ-104	T. Film	0.1M 50V	
C513	QFV71HJ-103	T. Film	0.01M 50V	C
C514	QFV71HJ-103	T. Film	0.01M 50V	C
C515	QFV71HJ-103	T. Film	0.01M 50V	C
C516	QFV71HJ-103	T. Film	0.01M 50V	C
C551	QET61HM-226	Electro	22M 50V	
C552	QET61CM-226	Electro	22U 16V	
C553	QET61AM-476	Electro	47M 10V	
C554	QET61AM-476	Electro	47M 10V	
C555	QFV71HJ-102	T. Film	0.001M 50V	
C556	QET52AM-474	Electro	0.47M 100V	
C557	QFV71HJ-153	T. Film	0.015M 50V	
C601	QFV71HJ-103	T. Film	0.01M 50V	
C602	QFV71HJ-103	T. Film	0.01M 50V	
C603	QET61EM-476	Electro	47M 25V	
C604	QET52AM-225	Electro	2.2M 100V	
C605	QET52AM-105	Electro	1M 100V	
C606	QFV71HJ-103	Electro	0.01M 50V	

△: Safety Parts

The column marked with □ indicates the area.

Parts without character in the column are used commonly regardless of delivery area.

Capacitors

Item No.	Part Number	Description	□
C607	QET61HM-225	Electro 2.2M 50V	
C608	QET61HM-105	Electro 1M 50V	
C609	QET51JM-107	Electro 100 63V	
C610	QET51JM-227	Electro 220M 63V	
C611	EEW91KM-189	Electro 18000M 80V	
C612	EEW91KM-189	Electro 18000M 80V	
C613	QFZ0074-104	M. Mylar 0.1M 250V	
C614	QFZ0074-224	M. Mylar 0.22M 250V	

Resistors

Item No.	Part Number	Description	□
R501	QVP4A0B-471	Variable 470 0.1W	
R502	QVP4A0B-471	Variable 470 0.1W	
R503	ERT-D2WFL351S	Thermister 350	
R504	ERT-D2WFL351S	Thermister 350	
R505	QRD141J-101S	Carbon 100 1/4W	
R506	QRD141J-101S	Carbon 100 1/4W	
R507	QRD141J-471S	Carbon 470 1/4W	
R508	QRD141J-471S	Carbon 470 1/4W	
R509	QRD141J-391S	Carbon 390 1/4W	
R510	QRD141J-391S	Carbon 490 1/4W	
R511	△ QRZ0062-101	Fusible 100 1/4W	
R512	△ QRZ0062-101	Fusible 100 1/4W	
R513	△ QRZ0062-101	Fusible 100 1/4W	
R514	△ QRZ0062-101	Fusible 100 1/4W	
R515	△ QRZ0062-470	Fusible 47 1/4W	
R516	△ QRZ0062-470	Fusible 47 1/4W	
R517	△ QRZ0062-470	Fusible 47 1/4W	
R518	△ QRZ0062-470	Fusible 47 1/4W	
R519	△ QRZ0062-182	Fusible 1.8K 1/4W	
R520	△ QRZ0062-182	Fusible 1.8K 1/4W	
R521	△ QRZ0061-2R2	Fusible 2.2 1/4W	
R522	△ QRZ0061-2R2	Fusible 2.2 1/4W	
R523	△ QRZ0061-2R2	Fusible 2.2 1/4W	
R524	△ QRZ0061-2R2	Fusible 2.2 1/4W	
R525	△ QRZ0062-271	Fusible 270 1/4W	
R526	△ QRZ0062-271	Fusible 270 1/4W	
R527	ERZ0001-R22	Emitter 0.22 3W	
R528	ERZ0001-R22	Emitter 0.22 3W	
R529	ERZ0001-R22	Emitter 0.22 3W	
R530	ERZ0001-R22	Emitter 0.22 3W	
R531	△ QRZ0061-2R2	Fusible 2.2 1/4W	
R532	△ QRZ0061-2R2	Fusible 2.2 1/4W	
R533	△ QRZ0061-2R2	Fusible 2.2 1/4W	
R534	△ QRZ0061-2R2	Fusible 2.2 1/4W	
R535	QRD141J-331S	Carbon 330 1/4W	
R536	QRD141J-331S	Carbon 330 1/4W	
R537	QRD141J-331S	Carbon 330 1/4W	
R538	QRD141J-331S	Carbon 330 1/4W	
R539	QRD141J-121S	Carbon 120 1/4W	
R540	QRD141J-121S	Carbon 120 1/4W	
R541	QRD141J-121S	Carbon 120 1/4W	
R542	QRD141J-121S	Carbon 120 1/4W	
R543	△ QRD125J-100	Fusible 10 1/2W	
R544	△ QRD125J-100	Fusible 10 1/2W	
R545	△ QRG022J-100A	O.M. Film 10 2W	

Item No.	Part Number	Description	□
R546	△ QRG022J-100A	O.M. Film 10 2W	
R547	△ QRZ0062-100	Fusible 10 1/4W	
R548	△ QRZ0062-100	Fusible 10 1/4W	C
R549	△ QRZ0062-100	Fusible 10 1/4W	C
R550	△ QRZ0062-100	Fusible 10 1/4W	C
R551	QRD141J-222S	Carbon 2.2K 1/4W	C
R552	QRD141J-222S	Carbon 2.2K 1/4W	
R553	QRD141J-183S	Carbon 18K 1/4W	
R554	QRD141J-183S	Carbon 18K 1/4W	
R555	QRD141J-223S	Carbon 22K 1/4W	
R556	QRD141J-223S	Carbon 22K 1/4W	
R557	QRD141J-103S	Carbon 10K 1/4W	
R558	△ QRD145J-221S	UNF. Carbon 220 1/4W	
R559	QRD141J-473S	Carbon 47K 1/4W	
R560	QRD141J-332S	Carbon 3.3K 1/4W	
R561	QRD141J-103S	Carbon 10K 1/4W	
R562	QRD141J-103S	Carbon 10K 1/4W	
R563	QRD141J-152S	Carbon 1.5K 1/4W	
R564	QRD141J-334S	Carbon 330K 1/4W	
R565	QRD141J-563S	Carbon 56K 1/4W	
R566	QRD141J-563S	Carbon 56K 1/4W	
R567	QRD141J-273S	Carbon 27K 1/4W	
R568	QRD141J-273S	Carbon 27K 1/4W	
R569	QRD141J-104S	Carbon 100K 1/4W	
R570	QRD141J-472S	Carbon 4.7K 1/4W	
R571	QRD141J-472S	Carbon 4.7K 1/4W	
R572	QRD141J-472S	Carbon 4.7K 1/4W	
R573	QRD141J-683S	Carbon 68K 1/4W	
R574	QRD141J-333S	Carbon 33K 1/4W	
R575	QRD141J-683S	Carbon 68K 1/4W	
R576	QRD141J-330S	Carbon 33 1/4W	
R577	QRD141J-470S	Carbon 47 1/4W	
R578	QRD141J-470S	Carbon 47 1/4W	
R579	QRD141J-470S	Carbon 47 1/4W	
R580	QRD141J-470S	Carbon 47 1/4W	
R581	QRD141J-470S	Carbon 47 1/4W	
R582	QRD141J-470S	Carbon 47 1/4W	
R583	QRD141J-470S	Carbon 47 1/4W	
R584	QRD141J-470S	Carbon 47 1/4W	
R585	QRD141J-470S	Carbon 47 1/4W	
R586	QRD141J-470S	Carbon 47 1/4W	
R587	△ QRD125J-273	UNF. Carbon 27K 1/2W	
R588	△ QRD125J-273	UNF. Carbon 27K 1/2W	
R589	△ QRD125J-273	UNF. Carbon 27K 1/2W	
R590	△ QRD125J-273	UNF. Carbon 27K 1/2W	
R591	△ QRG022J-471A	O.M. Film 470 2W	
R592	△ QRG022J-471A	O.M. Film 470 2W	
R593	QRD141J-102S	Carbon 1K 1/4W	
R594	QRD141J-102S	Carbon 1K 1/4W	
R601	QRD141J-433S	Carbon 43K 1/4W	
R602	QRD141J-433S	Carbon 43K 1/4W	
R603	QRD141J-473S	Carbon 47K 1/4W	
R604	QRD141J-473S	Carbon 47K 1/4W	
R605	QVP4A0B-103	Variable 10K 0.1W	
R606	QVP4A0B-103	Variable 10K 0.1W	
R607	QRD141J-472S	Carbon 4.7K 1/4W	
R608	QRD141J-472S	Carbon 4.7K 1/4W	
R609	QRD141J-472S	Carbon 4.7K 1/4W	
R610	QRD141J-472S	Carbon 4.7K 1/4W	
R611	QRD141J-153S	Carbon 15K 1/4W	

△: Safety Parts

The column marked with □ indicates the area.

Parts without character in the column are used commonly regardless of delivery area.

Resistors

Item No.	Part Number	Description	<input type="checkbox"/>
R612	QRD141J-153S	Carbon 15K 1/4W	
R613	QRD141J-472S	Carbon 4.7K 1/4W	
R614	QRD141J-271S	Carbon 270 1/4W	
R615 Δ	QRD125J-332	UNF. Carbon 3.3K 1/2W	
R616 Δ	QRD125J-332	UNF. Carbon 3.3K 1/2W	
R617	QRD141J-223S	Carbon 22K 1/4W	
R618	QRD141J-563S	Carbon 56K 1/4W	
R619	QRD141J-473S	Carbon 47K 1/4W	
R620	QRD141J-823S	Carbon 82K 1/4W	
R621	QRD141J-153S	Carbon 15K 1/4W	
R622	QRD141J-473S	Carbon 47K 1/4W	
R623	QRD141J-154S	Carbon 150K 1/4W	
R624	QRD141J-472S	Carbon 4.7K 1/4W	
R625	QRD141J-185S	Carbon 1.8M 1/4W	
R626	QRD141J-474S	Carbon 470K 1/4W	
R627	QRD141J-224S	Carbon 220K 1/4W	
R628	QRD141J-474S	Carbon 470K 1/4W	
R629	QRD141J-333S	Carbon 33K 1/4W	
R630	QRD141J-122S	Carbon 1.2K 1/4W	
R631	QRD141J-472S	Carbon 4.7K 1/4W	
R632	QRD141J-472S	Carbon 4.7K 1/4W	
R633	QRD141J-103S	Carbon 10K 1/4W	
R634	QRD141J-103S	Carbon 10K 1/4W	
R635 Δ	QRD145J-4R7S	UNF. Carbon 4.7K 1/4W	
R636 Δ	QRD145J-4R7S	UNF. Carbon 4.7K 1/4W	
R637 Δ	QRD145J-2R2S	UNF. Carbon 2.2K 1/4W	
R638 Δ	QRD145J-2R2S	UNF. Carbon 2.2K 1/4W	
R639 Δ	QRD145J-4R7S	UNF. Carbon 4.7K 1/4W	
R641	QRD141J-822S	Carbon 8.2K 1/4W	
R642	QRD141J-103S	Carbon 10K 1/4W	
R643 Δ	QRD145J-150S	UNF. Carbon 15 1/4W	
R644 Δ	QRD145J-150S	UNF. Carbon 15 1/4W	
R645 Δ	QRD125J-122	UNF. Carbon 1.2K 1/2W	
R646 Δ	QRD125J-152	UNF. Carbon 1.5K 1/2W	
R647	QRD141J-563S	Carbon 56K 1/4W	
R648	QRD141J-154S	Carbon 150K 1/4W	
R649	QRD141J-154S	Carbon 150K 1/4W	

Others

Item No.	Part Number	Description	<input type="checkbox"/>
	E67764-105	Terminal	
	E10861-101	Circuit Board	
	E03798-002	Bus Bar	
	E03798-003	Bus Bar	
	E302101-001	Heat Sink Bracket	
	E302806-001	Heat Sink Bracket	
	E302807-001	E. Capacitor Holder	
	SBSB3008CC	Screw	
	SBSE3012CC	Screw (for P. Transistor)	
	E300209-013	Heat Sink	
	E70306-002	Heat Sink	
	E70945-H25	Heat Sink	
	EX0025010N30	Spacer	
J501	EMB00TP-801C	Speaker Terminal	
J502	QMS6302-121	Headphone Jack	
J601	E04362-002	2P Plug Ass'y	
J602	E04362-003	3P Plug Ass'y	
P501	E03628-5UD	5 Pin Plug	
S501	QSS4401-001	Slide Switch	
RY551	ESK5D24-214	Relay	

Coils

Item No.	Part Number	Description	<input type="checkbox"/>
L501	EQL0003-1R0	Choke Coil 1 μ H	
L502	EQL0003-1R0	Choke Coil 1 μ H	

Δ : Safety Parts

The column marked with indicates the area.

Parts without character in the column are used commonly regardless of delivery area.

3-(4) TPS-255 H AC Outlet P. C. Board Ass'y

Note: The symbols (赤、黒、白 etc.) on P.C. Board surface are factory process only.

■ for U.S.A., Canada

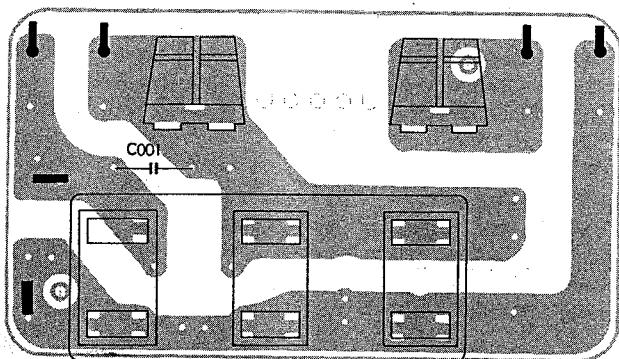

Fig. 8

Capacitor

Item No.	Part Number	Description	<input type="checkbox"/>
C001	△ QCZ9019-103	Ceramic 0.01M	

Others

Item No.	Part Number	Description	<input type="checkbox"/>
△	E66003-005	Circuit Board	
	QMC0637-004	3P AC Socket	
	E03675-004	Fuse Clip	
	E43727-001	Tab	
	E65508-001	Tab	

△:Safety Parts

3-(5) TPS-287 □ AC Outlet P. C. Board Ass'y

Note: The symbols (赤、黒、白 etc.) on P.C. Board surface are factory process only.

The Marks for Designated Areas

E Australia, Europe, West Germany

FBS.. U. K.

D..... U.S. Military Market, Other Countries

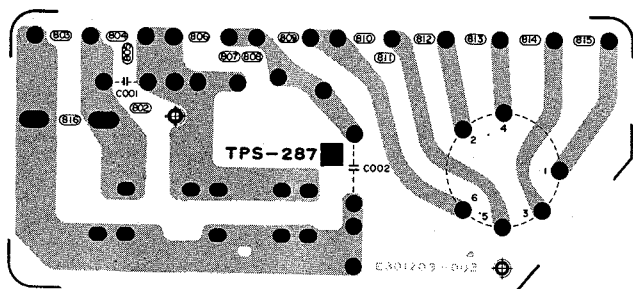

Fig. 9

Capacitors

Item No.	Part Number	Description	<input type="checkbox"/>
C001	△ QCZ9019-103	Ceramic 0.01M	E, D FBS
	QFZ9010-103BS	M. Poly 0.01M	

Others

Item No.	Part Number	Description	<input type="checkbox"/>
△	E301203-001	Circuit Board	E, D FBS E, D FBS
	E301203-001BS	Circuit Board	
	QSR0085-001U	Voltage Selector	
	QSR0085-001UBS	Voltage Selector	
	E67448-001	Holder	
	SBSB3008Z	Tapping Screw	
	E43727-002	Tab	
	E65508-002	Tab	

△:Safety Parts

The column marked with □ indicates the area.

Parts without character in the column are used commonly regardless of delivery area.

4. Packing Materials and Parts Numbers

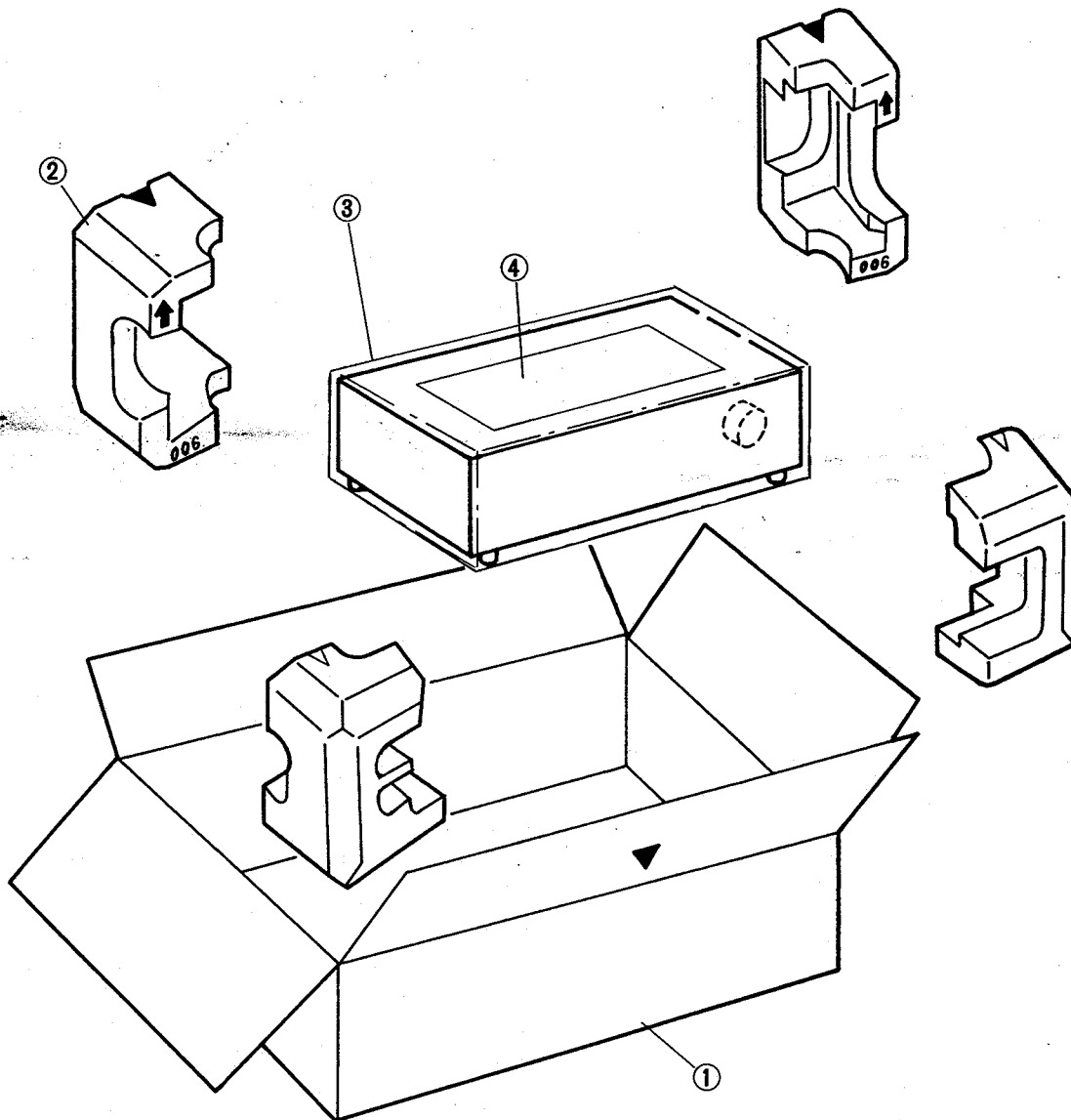

Fig. 10

No.	Part Number	Part Name	Q'ty	Description	Area
1	PK-AX900E	Packing Case	1	E300382-341	
2	NZ-AX900	Packing Pad	1	E24600-005 (Front)	
	NZ-AX900	Packing Pad	1	E24600-006 (Back)	
3	E34033-012	Envelope	1		J, C, U, P, E, A, G
	E34033-012B	Envelope	1		BS
4	E35497-013	Caution Sheet (110V)	1		U, P
	E35497-014	Caution Sheet (120V)	1		U, P
	E35497-015	Caution Sheet (220V)	1		E, G, P, U
	E35497-016	Caution Sheet (240V)	1		A, BS, U, P
	E302237-004	Sheet Ass'y	1		
	E35246-001	Serial Label	2		J, C, U, P, A, BS
	E35246-004	Serial Label	2		E
	E35246-006	Serial Label	2		G

The Marks for Designated Areas

J.....	U. S. A.	P.....	U. S. Military Market
C.....	Canada	BS.....	U. K.
E.....	Europe	A.....	Australia
G.....	West Germany	U.....	Other Countries

5. Accessories List

The Marks for Designated Areas

J..... U. S. A.	P..... U. S. Military Market
C..... Canada	BS..... U. K.
E..... Europe	A..... Australia
G..... West Germany	U..... Other Countries

Part Name	Part Number	Area
Instruction Book	E30580-1153A	J, C, U, P, E, A, G
Instruction Book	E30580-1153ABS	BS
Warranty Card	BT20048A	J, P
JVC Service Information Card	BT20046B	J, P
F.T.Z. Information Card	BT20054-006A	G
Envelope (for Warranty Card)	E66416-003	J
Pin Jack Cover	E302802-001	
Protect Sheet (150 x 140)	E36997-088	
JVC Safety Instruction Sheet	BT20044D	J
Warranty Card	BT20025G	C
Fuse (T8A/250V)	QMF51A2-8R0L	U
Fuse (T4A/250)	QMF51A2-4R0S	P
Fuse Label (T8A)	E67142-T8R0	U, P
Fuse Label (T4A)	E67142-T4R0	U, P
Envelope (for Fuse)	E64208-001	U, P
Warranty Card	BT20029C	A
Warranty Card	BT20060	BS
Envelope	E41202-2	J, C, U, P, E, A, G
Envelope	E41202-2B	BS
EEC Agency	BT20066	BS, G
Service Center List	BT20071	C
Warranty Card	BT20064	G