

SERVICE MANUAL

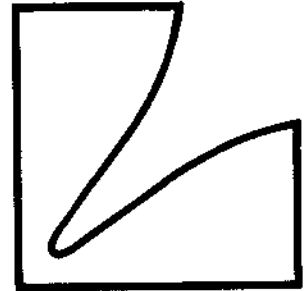

Digital Synthesized AM/FM Stereo Tuner
TV JAPAN ONLY

T-117/T-117L
T-03/T-03L

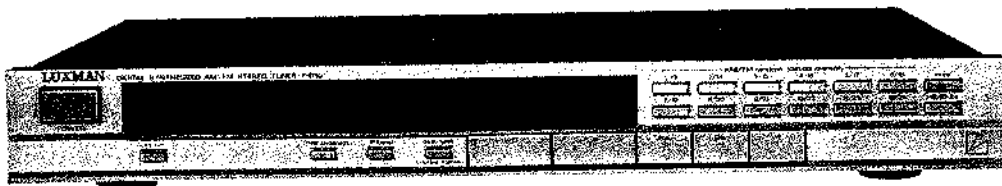

T-03L



T-117

Contents

Specifications	3
Parts Locations and Disassembly Instructions	4
Adjustment Procedures	8
Adjustment Locations	16
Block Diagram	17
FM Tuner Schematic Diagram	19
TV Tuner Schematic Diagram	21
Schematic Diagram Switch. Display(1/3)(JA/EK/SD/UZ model)	23
Schematic Diagram Main(2/3)(JA model)	27
Schematic Diagram main(3/3)(EK/SD/UZ model)	31
Parts Layout on P.C.B. Boards and Wiring Diagram	35
Electrical Parts List	45
Cabinet Assembly Parts List	54
Exploded View(Cabinet)	55
Packing Method View	57
Packing Assembly Parts List	58
Semi-Conductor Lead Identifications	59

Specifications

<FM RADIO>

Intermediate Frequency	10.7MHz
Frequency Range	76.1~89.9MHz(JA Model Only) 87.5~108MHz(SD, EK Model) 87.9~107.9MHz(UZ Model Only)
Usable Sensitivity	13dBf(JA, EK, UZ Model) 16dBf(SD Model Only)
(Mono 3% T.H.D)	
Signal to Noise Ratio(Stereo)	70dB
Image Response Ratio	70dB
IF Response Ratio	96dB
Distortion(1KHz, Stereo)	0.2%
Stereo Separation(1KHz)	40dB
Frequency Response(30Hz ~15KHz)	±1.5dB
Quieting Sensitivity(Stereo, 50dB S/N)	45dBf
Output Level(Mono)	700mV±3dB

<AM(MW) RADIO>

Intermediate Frequency	450KHz
Frequency Range	522~1611KHz(JA, SD, EK Model) 530~1620KHz(UZ Model Only)
Usable Sensitivity(20dB S/N)	76.2dBf
Signal to Noise Ratio	42dB
Image Response Ratio(1KHz)	30dB
IF Response Ratio	40dB
Distortion	1%
Frequency Response(120Hz~2KHz)	±3dB
Output Level	210mV±3dB

<LW RADIO> (SD Model Only)

Intermediate Frequency	450KHz
Frequency Range	153 ~ 281KHz
Usable Sensitivity(20dB S/N)	89.2dBf
Image Response Ratio	25dB
IF Response Ratio	27dB
Distortion	1%
Output Level	210mV±3dB
S/N Ratio	42dB

<TV> (JA Model Only)

Intermediate Frequency	54.25MHz
Channel Range	1 ~ 62ch
Usable Sensitivity(30dB S/N)	2ch: 20dBf 32ch: 25dBf
Signal to Noise Ratio	2ch Mono: 48dB Stereo: 45dB Main: 48dB Sub: 48dB 32ch Mono: 40dB Stereo: 40dB Main: 40dB Sub: 40dB
Frequency Response(50Hz ~10KHz)	±1.5dB
Distortion(2ch, 1KHz, Stereo)	1.8%
Channel Separation(1KHz)	Stereo 25dB Main-Sub 40dB Sub-Main 45dB
Output Level	700mV±3dB

<GENERAL>

Power Supply	100V, 50/60Hz(JA Model Only) 220V, 50Hz(SD, EK Model) 120V, 60Hz(UZ Model Only)
Power Consumption	15W
Semiconductors	

24IC's 59 Transistors, 8 FET's, 73 Diodes, 10 Zener Diodes
(JA Model Only)
21IC's 57 Transistors, 6 FET's, 62 Diodes, 10 Zener Diodes
(SD Model Only)
21IC's 49 Transistors, 3 FET's, 59 Diodes, 10 Zener Diodes
(EK Model Only)
21IC's 50 Transistors, 6 FET's, 61 Diodes, 10 Zener Diodes
(UZ Model Only)

Dimensions	453(W)×62(H)×323(D) mm
Weight	3.8Kg

Parts Locations and Disassembly Instructions

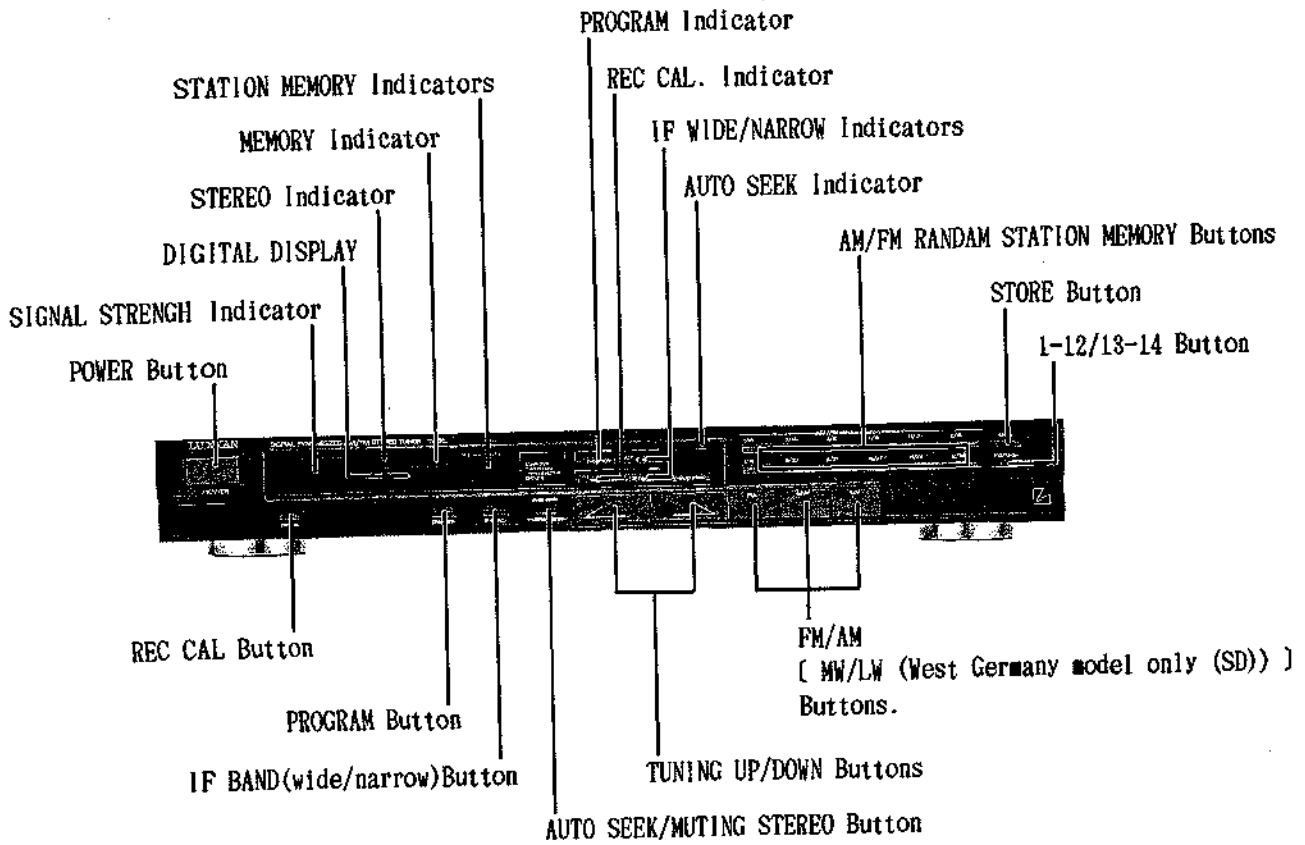

Figure 1

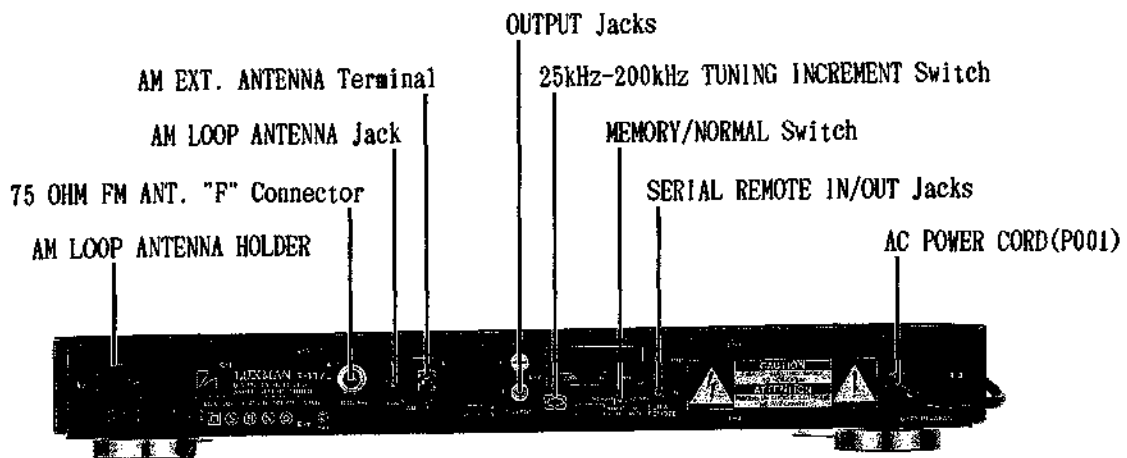
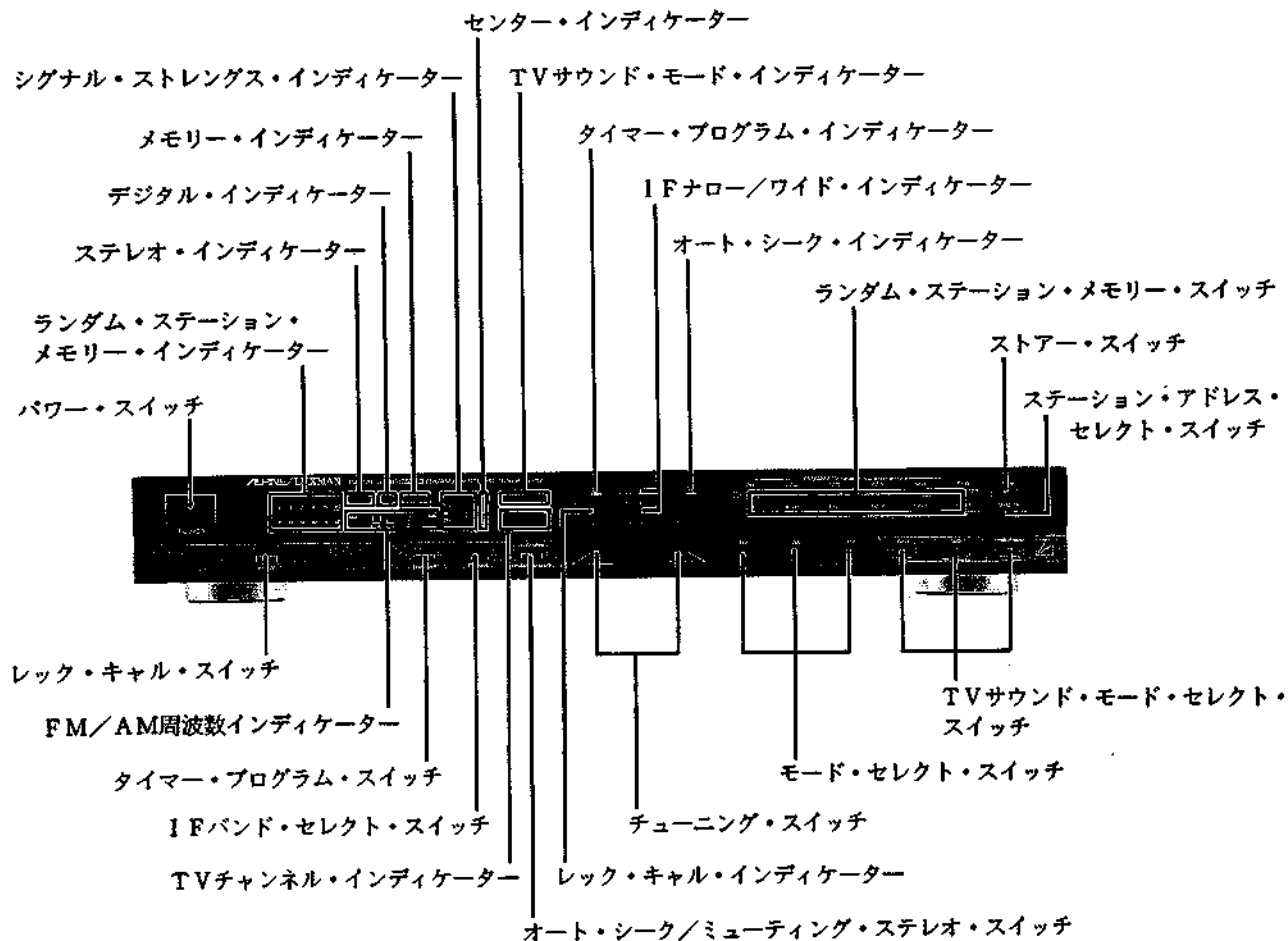
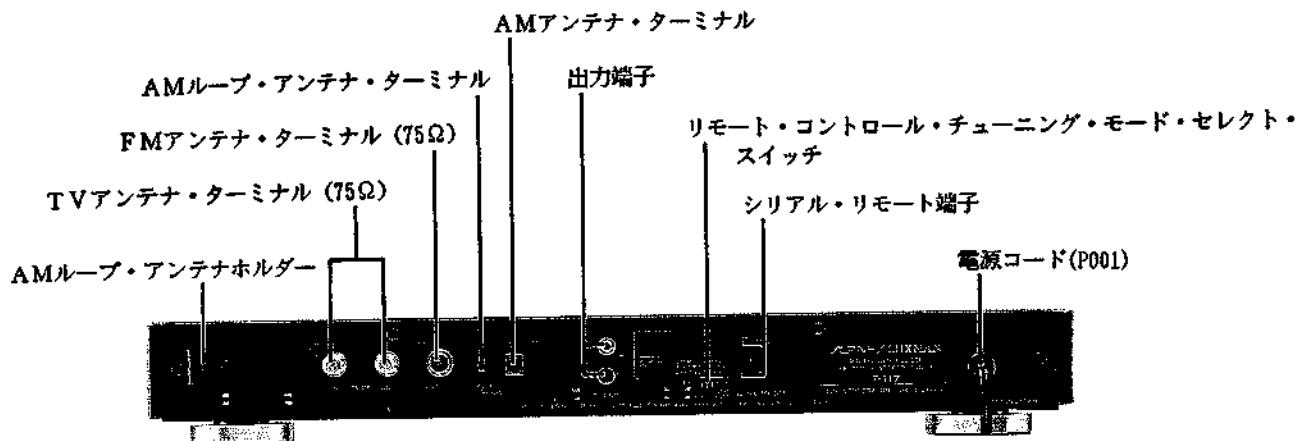

Figure 2

• Japanese model only (JA)



< 3 図 >



< 4 図 >

1. Removal of Top Cover

- (1) Remove six screws marked "○" as shown in Figure 5 and 6.
- (2) Pull out the Top cover in the direction of the arrow as shown in Figure 3.

1. 上蓋の外し方

- (1) 6本のネジ "○" を外します。(5, 6図参照)
- (2) 矢印の方向に引き上げれば、上蓋は外すことができます。(3図参照)

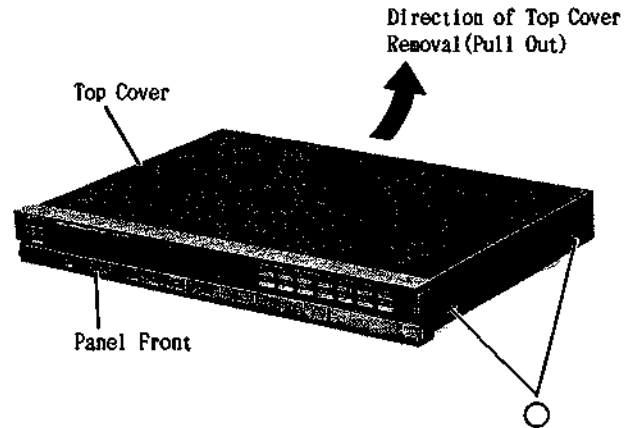

Figure 5
< 5図 >

2. Removal of Main P.C. Board

- (1) After removal of Top cover, remove eleven screws marked "※" as shown in Figure 6 and 7.
- (2) Disconnect all wires from the Main P.C. Board.
- (3) Main P.C. Board can be removed by pulling it forward.

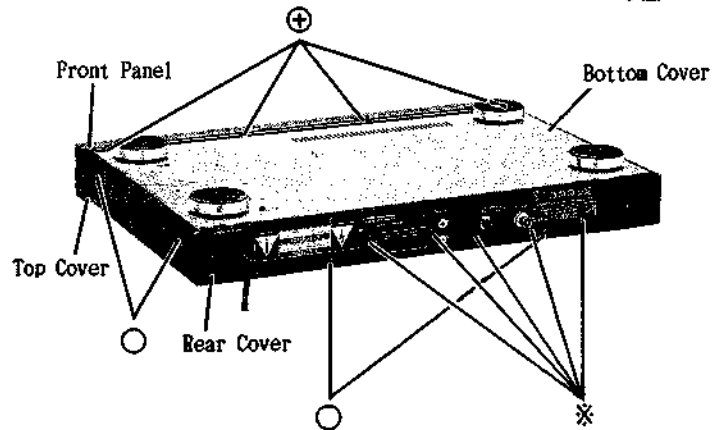

Figure 6
< 6図 >

2. メイン基板の外し方

- (1) 上蓋を外してから11本のネジ "※" を外します。(6, 7図参照)
- (2) メイン基板から出ているすべてのリードを外します。
- (3) メイン基板を手前に引いて外します。

3. Removal of Front Panel

- (1) Remove six screws marked "⊕" as shown in Figure 6 and 7.
- (2) Front panel can be removed by pulling it forward. But when the panel is engaged tightly, pull the panel end little by little, and the panel will be removed easily.

3. フロント・パネルの外し方

- (1) 上蓋を外してから、6本のネジ "⊕" を外します。(6, 7図参照)
- (2) フロント・パネルを手前に引いて外します。パネルを外すときパネルはセットにしっかりと取りついておりますので、パネルの両端を持って少しずつ引くようにして外してください。

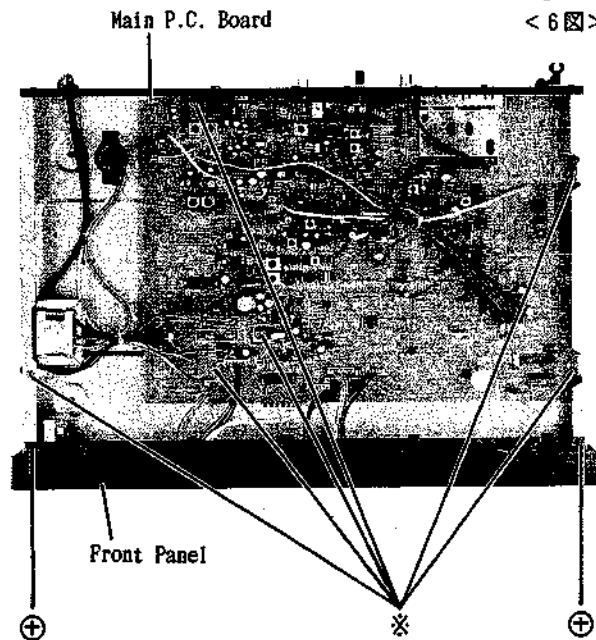

Figure 7
< 7図 >

4. Removal of Front Frame

- (1) After removal of Front Panel, remove eight hooks(a) as shown in Figure 8 and 9.
- (2) Unplug all the connectors from the display P.C. board and switch P.C. board. The front frame will be removed together with the P.C. boards.

4. フロント・フレームの外し方

- (1) フロント・パネルを外してから、8個のホック(a)を外します。(8、9図参照)
- (2) ディスプレイ基板、スイッチ基板から出ている全てのコネクタを外しますと、各基板と一緒にフロント・フレームは外れます。

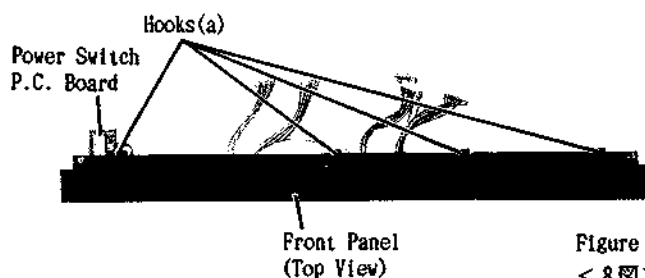

Figure 8
< 8図 >

5. Removal of Display P.C. Board

- (1) After removal of Front Frame, remove three screws marked "◎" as shown in Figure 10.
- (2) Remove three hooks(b) as shown in Figure 10.

5. ディスプレイ基板の外し方

- (1) フロント・パネルを外してから、3本のネジ "◎" を外します。(10図参照)
- (2) 3個のツメ(b)を外しますと、ディスプレイ基板は外れます。

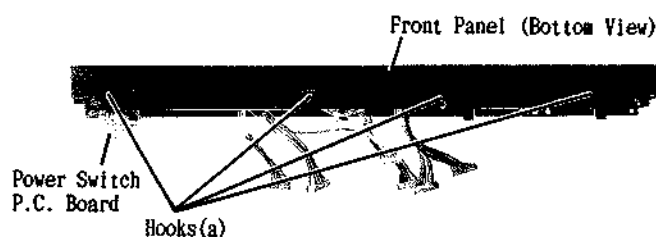

Figure 9
< 9図 >

6. Removal of Switch P.C. Board

- (1) After removal of Front Frame, remove three screws marked "□" as shown in Figure 10.
- (2) Remove eight hooks(c) as shown in Figure 10.

6. スイッチ基板の外し方

- (1) フロント・フレームを外してから、3本のネジ "□" を外します。(10図参照)
- (2) 8個のツメ(c)を外しますと、スイッチ基板は外れます。

7. Removal of Power Switch P.C. Board

- (1) After removal of Front Frame, remove two screws marked "回" as shown in Figure 10.

7. パワースイッチ基板の外し方

- (1) フロントフレームを外してから、2本のネジ "回" を外しますと、パワースイッチ基板は外れます。(10図参照)

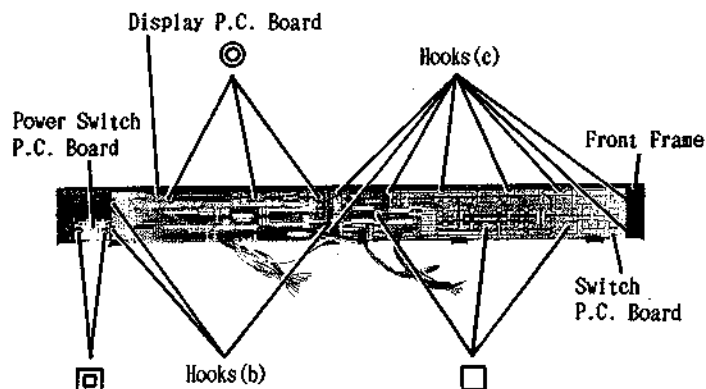

Figure 10
< 10図 >

Adjustment Procedures

MW(SD Model Only) . AM(EK/UZ Model)

(1) Connection

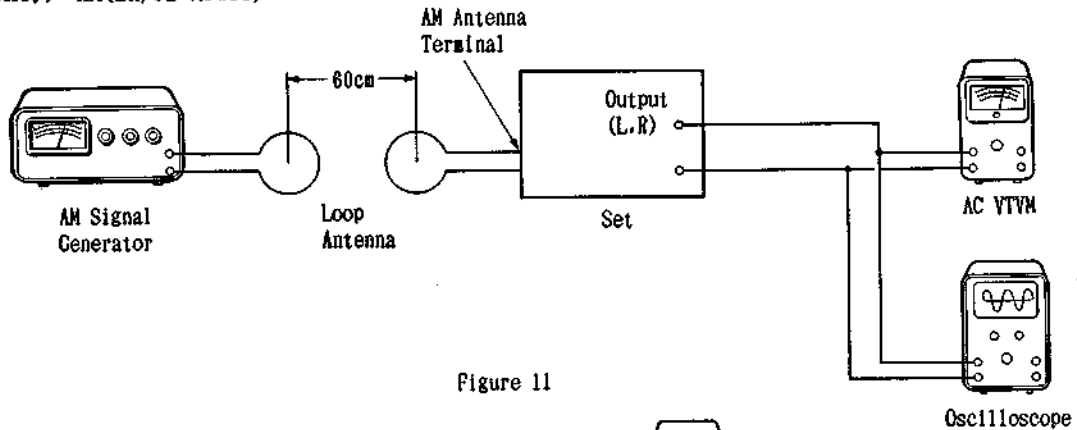

Figure 11

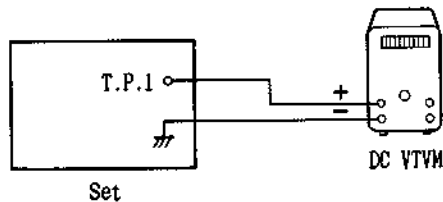

Figure 12

(2) Control Setting

Power Switch.....ON
FM/AM/(MW/LW) Switch.....AM(MW)
others.....OFF

(3) Adjustment(EK.SD.UZ Model)

step	Description	Signal Generator	Dial Control	Adjust Points	Test Points	Connection	Remarks
1	Vf Adjustment		603KHz(EK.SD)	L306	TPI	Figure 12	Adjust Vf to $2.2 \pm 0.1V$ at L306
			600KHz(UZ)	VC304			Adjust Vf to $7.1 \pm 0.1V$ at VC304
2	Sensitivity Adjustment	603KHz(EK.SD)	603KHz(EK.SD)	L302	Output (L,R)	Figure 11	Adjust the output to maximum at L302
		600KHz(UZ)	600KHz(UZ)	VC302			Adjust the output to maximum at VC304
3	SIG IND & MUTE level Adjustment	1008KHz(EK.SD) 1000KHz(UZ) 55dBm (400Hz, 30%)	1008KHz(EK.SD) 1000KHz(UZ)	VR302 VR301 VR501	Output (L,R)	Figure 11	Set VR501 to the position which is slightly turned counterclockwise from horizontal. Adjust the level to $55dBm \pm 12dB$ at VR302 with the MUTE switch set to ON. Adjust the level to $75 +20, -10 dBm$ at both VR501 and VR301 so that one or two elements of SIG IND light up. Note: For the section marked with *, refer to VR501 shown in Fig. 21.

調整方法

AM(JA Model Only)

(1) 接続図

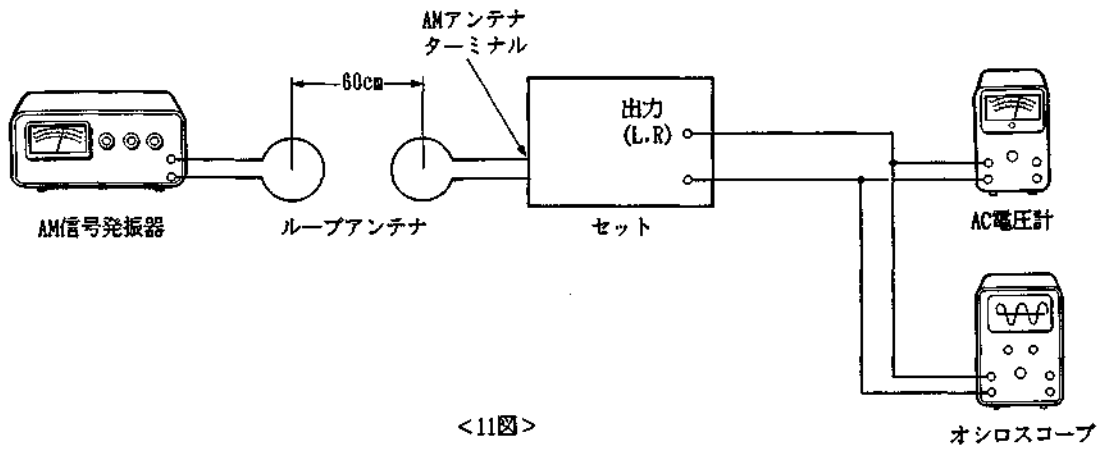

<11図>

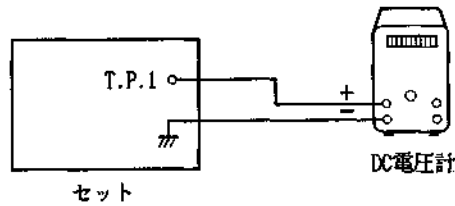

<12図>

(2) スイッチ類のセット位置

電源スイッチ.....ON
FM/AM/TVスイッチ.....AM
その他.....OFF

(8) 調整方法 (JAモデル)

順序	調整項目	発振器周波数	受信周波数	調整箇所	テストポイント	接続図	調整方法
1	V f 調整		603KHz	L306	T.P.1	12図	L306で $2.2 \pm 0.1V$ に調整
			1404KHz	VC304			VC304で $7.1 \pm 0.1V$ に調整
2	感度調整	603KHz 60dBm (400Hz, 30%)	603KHz	L302	出力(L,R)	11図	L302で出力最大に調整
		1404KHz 60dBm (400Hz, 30%)	1404KHz	VC302			VC302で出力最大に調整
3	SIG. IND & MUTE レベル調整	1008KHz 55dBm (400Hz, 30%)	1008KHz	VR302 VR301 VR501	出力(L,R)	11図	VR501を水平より少し反時計方向より設定し、MUTE-SW ON状態でVR302で $55dBm \pm 1dB$ に調整、この時SIG. INDが1~2点灯する様VR301とVR501で $75 \pm 20, -10dBm$ に調整 (注) *印は21図のVR501を参照願います。

LW(SD Model Only)

(1) Connection

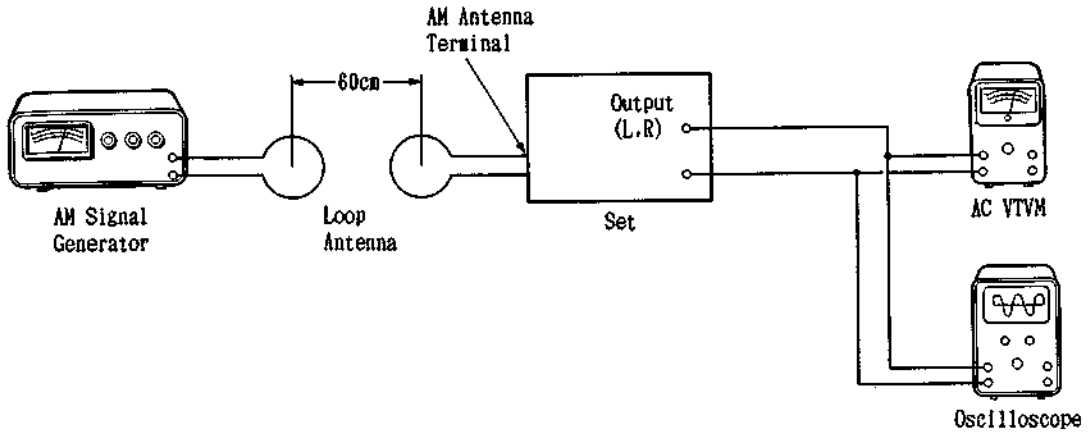

Figure 13

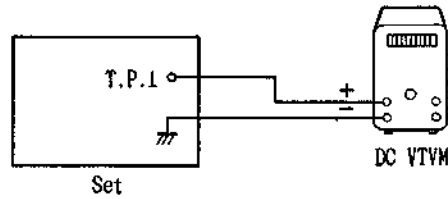

Figure 14

(2) Control Setting

Power Switch.....ON
 FM/AM/(MW/LW) Switch.....LW
 others.....OFF

(3) Adjustment

step	Description	Signal Generator	Dial Control	Adjust Points	Test Points	Connection	Remarks
1	Vf Adjustment		180KHz	L305	TP1	Figure 14	Adjust Vf to $2.4 \pm 0.1V$ at L305
			261KHz	VC303			Adjust Vf to $5.3 \pm 0.1V$ at VC303
2	Sensitivity Adjustment	180KHz.90dBm (400Hz.30%)	180KHz	L301	Output (L,R)	Figure 13	Adjust the output to maximum at L301
		261KHz.90dBm (400Hz.30%)	261KHz	VC301			Adjust the output to maximum at VC301

FM(SD/EK/UZ Model)

(1) Dummy Antenna

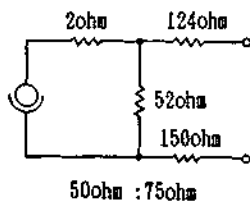

Figure 15

(2) Connector

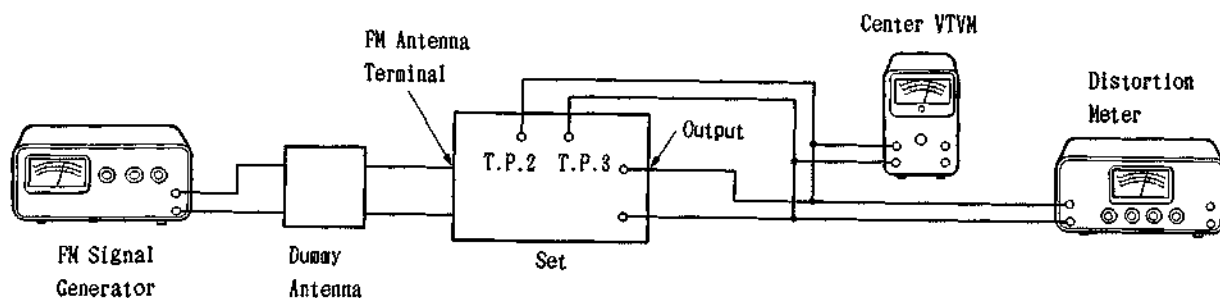

Figure 16

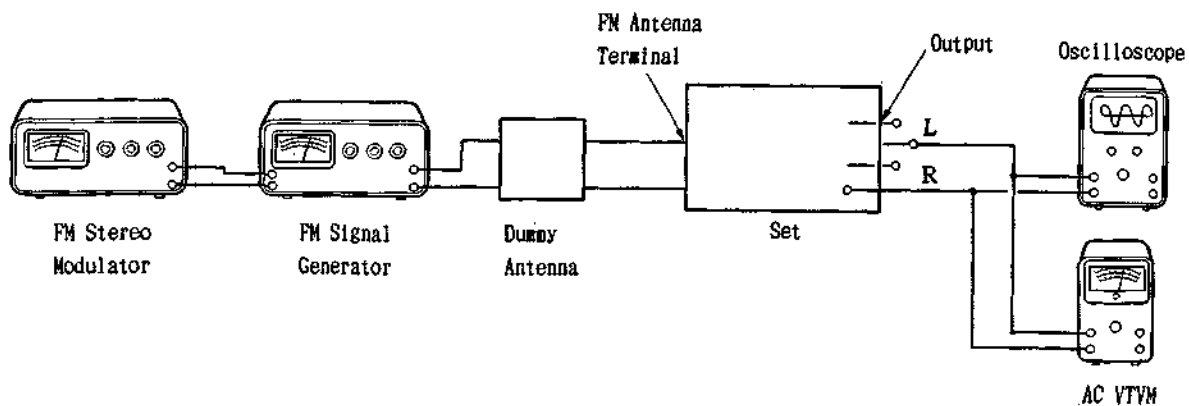

Figure 17

(3) Control Setting

Power Switch.....ON
FM/AM/(HW/LW) Switch.....FM
others.....OFF

(4) Adjustment (EK, SD, UZ model)

step	Description	Signal Generator	Dial Control	Adjust Points	Test Points	Connection	Remarks
1	IF Adjustment	98.1MHz 65dBf Non Modulation	98.1MHz	L105	T.P.2 T.P.3	Figure 16	Adjust the level to $0 \pm 20mV$ at L105
2	Mono Distortion Adjustment	98.1MHz 36dBf 1KHz, 75KHz Deviation	98.1MHz	VR204 L206 L205 L101 L208 L209	Output (L,R)	Figure 18	Turn VR202 fully clockwise and VR201 fully counterclockwise. Adjust the output to 700mV at VR404. Turn VR204 fully counterclockwise and turn it clockwise little by little until the distortion will lower twice. AT this position adjust the distortion to minimum. Readjust VR404 to 700mV and adjust the distortion to minimum at L206, L205, L101, L208 and L209 in this order.
3	STEREO Distortion Adjustment	98.1MHz 36dBf 1KHz, 75KHz Deviation	98.1MHz	L104	Output (L,R)	Figure 16	Adjust the distortion to minimum at L104.
4	Pulse Detection Output Adjustment	98.1MHz 36dBf 1KHz, 75KHz Deviation	98.1MHz	VR404	Output (L,R)	Figure 16	Adjust the output to 700mV +0.5dB at VR404 with the REC CAL switch set to ON.
5	PLL Detection Output Distortion Adjustment	98.1MHz 36dBf 1KHz, 75KHz Deviation	98.1MHz	VR201 VR203 L202	Output (L,R)	Figure 16	Turn VR201 fully clockwise. Adjust the output to 700mV +0.5dB at VR203. Adjust the distortion to minimum at L202.
6	PUL/pulse Detection Output Switching Level Adjustment	98.1MHz 36dBf 1KHz, 75KHz Deviation	98.1MHz	VR201	Output (L,R)	Figure 16	Adjust at VR201 so that the output level is varied from 700mV $\pm 0.5dB$ to 700mV +1.5dB.
7	PLL Detection Output Adjustment	98.1MHz 36dBf 1KHz, 75KHz Deviation	98.1MHz	VR203	Output (L,R)	Figure 16	Adjust the output to 700mV +1.5dB at VR203 with the REC CAL switch set to ON.
8	SIG IND Light Adjustment	98.1MHz 19dBf (EK, UZ) 22dBf (SD)	98.1MHz	VR103 VR102	Output (L,R)	Figure 16	Turn VR103 fully counterclockwise. Adjust at VR102 so that the first element of SIG IND lights up
9	IF NARROW Again Adjustment	98.1MHz 66dBf 1KHz, 75KHz Deviation L(R) signal	98.1MHz	VR101	Output (L,R)	Figure 16	Adjust at VR101 so that SIG IND lights up, with the NARROW switch set to ON.
10	Separation Adjustment	98.1MHz 66dBf 1KHz, 75KHz Deviation L(R) signal	98.1MHz	VR401 VC401 VR402 VC402	Output (L,R)	Figure 17	Receive an L-channel to minimum at VR401 and VC401. (Adjust the waveform leaking to L-channel to minimum at VR402 and VC402.)

FM(JA Model Only)

(1) ダミーアンテナ

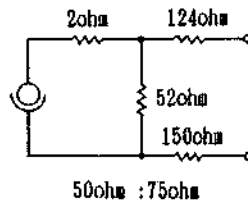

<15図>

(2) 接続図

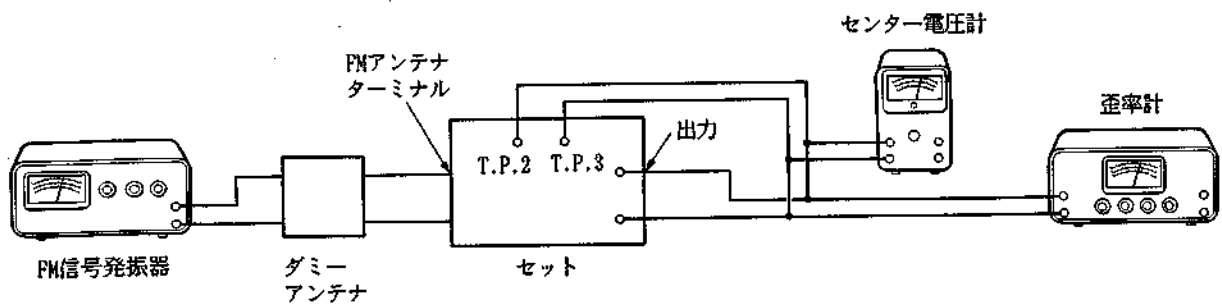

<16図>

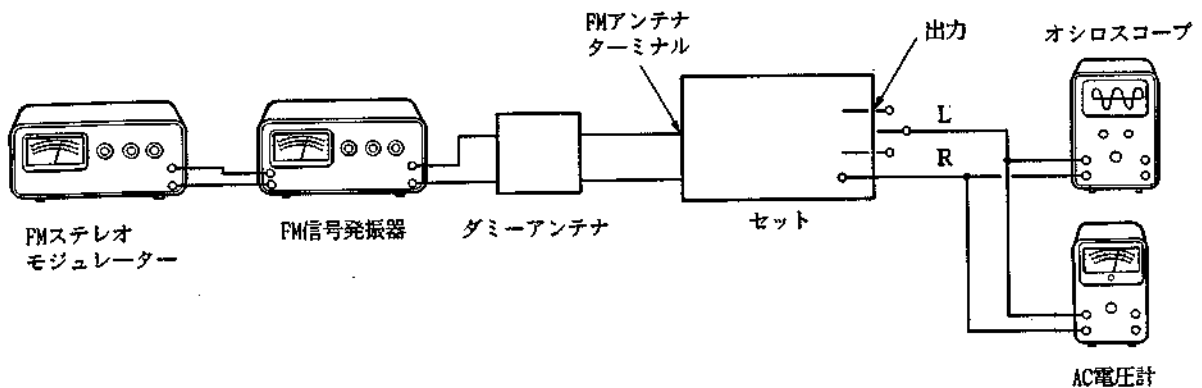

<17図>

(3) スイッチ類のセット位置

- 電源スイッチ.....ON
- FM/AM/TVスイッチ.....FM
- その他.....OFF

(4) 調整方法 (JAモデル)

順 序	調整項目	発振器周波数	受信周波数	調整箇所	テスト ポイント	接続図	調 整 方 法
1	1F調整	84MHz 65dBf Non Modulation	84MHz	L105	T.P.2 T.P.3	16図	L105で $0 \pm 20\text{mV}$ に調整
2	モノラル歪調整	84MHz 36dBf 1KHz, 75KHz Deviation	84MHz	VR204 L206 L205 L101 L208 L209	出力 (L,R)	16図	VR202 を時計方向, VR201 を反時計方向に廻し切り, VR404 で出力を700mVに設定し, VR204 を反時計方向に廻し切り, 少しずつ戻し歪が2度目に小さくなる所で最小にする。VR404 を再度700mVに設定し, L206, L205, L101, L208, L209の順で歪を最小にする。
3	ステレオ歪調整	84MHz 36dBf 1KHz, 75KHz Deviation	84MHz	L104	出力 (L,R)	16図	L104で歪を最小にする。
4	パルス検波 出力調整	84MHz 36dBf 1KHz, 75KHz Deviation	84MHz	VR404	出力 (L,R)	16図	レック・キャル・スイッチ-ON VR404 で700mV+1.5dB に調整
5	PLL 検波 出力歪調整	84MHz 36dBf 1KHz, 75KHz Deviation	84MHz	VR201 VR203 L202	出力 (L,R)	16図	VR201 を時計方向に廻し切り, VR203 で出力を700mV+0.5dB に調整し, L202で歪を最小にする。
6	PLL/パルス 検波出力 切換レベル調整	84MHz 36dBf 1KHz, 75KHz Deviation	84MHz	VR201	出力 (L,R)	16図	VR201 で700mV+0.5dB から 700mV+1.5dB に変化する様調整
7	PLL 検波 出力調整	84MHz 36dBf 1KHz, 75KHz Deviation	84MHz	VR203	出力 (L,R)	16図	レック・キャル・スイッチ-ON VR203 で700mV+1.5dB に調整
8	SIG IND 点灯調整	84MHz 19dBf 1KHz, 75KHz Deviation	84MHz	VR103 VR102	出力 (L,R)	16図	VR103 を反時計方向に廻し切り, VR102 でシグナル・インディケータ 第1灯が点灯する様調整
9	1F, NARROW ゲイン調整	84MHz 19dBf 1KHz, 75KHz Deviation	84MHz	VR101	出力 (L,R)	16図	NARROW SW-ON VR101 でシグナル・インディケータ が点灯する様調整
10	セパレーション 調整	84MHz 60dBf 1KHz, 75KHz Deviation L(R)信号	84MHz	VR401 VC401 VR402 VC402	出力 (L,R)	17図	Lchを受信し, Rchへのもれ波形 をVR401, VC401 で最小にする。 (Rchも同様にVR402, VC402 で 最小にする)

TV(JA Model Only)

(1) 接続図

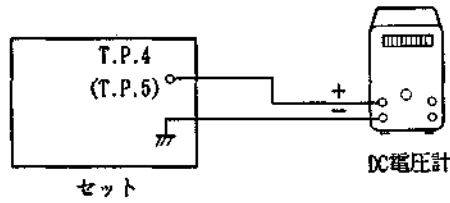

<18図>

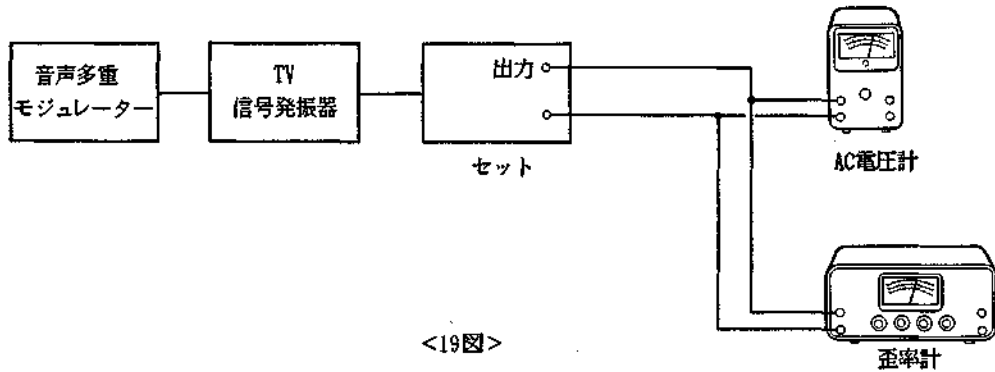

<19図>

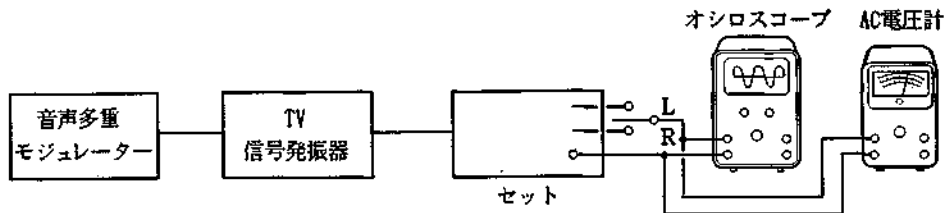

<20図>

(2) スイッチ類のセット位置

電源スイッチ.....ON
FM/AM/TVスイッチ.....TV
その他.....OFF

(3) 調整方法 (JAモデル)

順序	調整項目	発振器周波数	受信周波数	調整箇所	テストポイント	接続図	調整方法
1	AGC 電圧調整	2ch 101.75MHz 75dB μ 1KHz, 25KHz Deviation	2ch 101.75MHz	VR104	T.P.4	18図	VR104 で $4\pm 1.0V$ に調整
2	感度調整	2ch 101.75MHz 20dB μ Non Modulation	2ch 101.75MHz	L604	出力	19図	L604 で歪を最小に調整
3	FILTER調整	2ch 101.75MHz 64dB μ ステレオ	2ch 101.75MHz	VR701	T.P.5	18図	VR701 で電圧を最大に調整
4	セパレーション調整	2ch 101.75MHz L(R)信号 1KHz, 25KHz Deviation	2ch 101.75MHz	VR702	出力	20図	VR702 で L \rightarrow R, R \rightarrow L の もれが同一になる様調整

Adjustment Locations

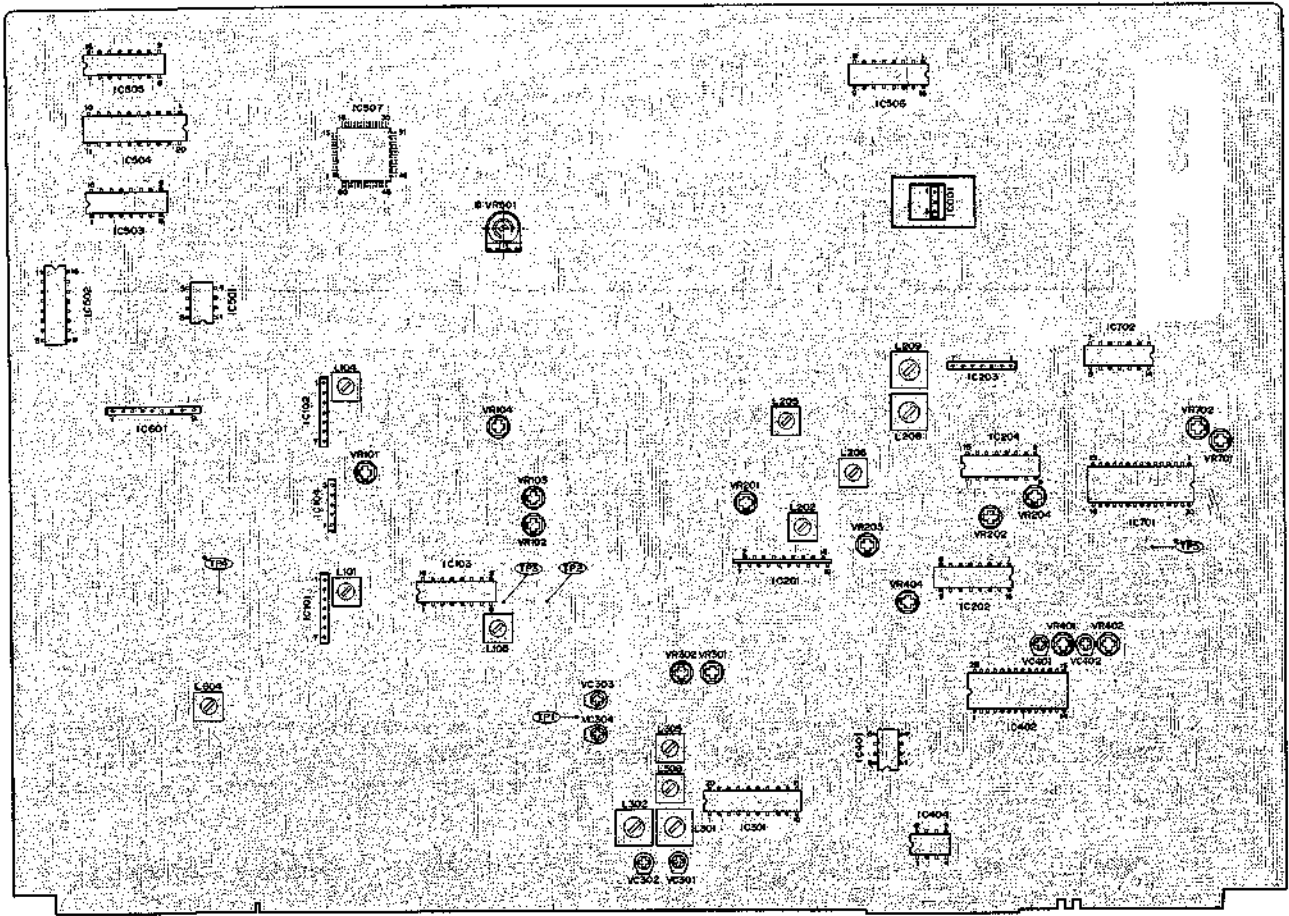

Note: e-For Japanese model only (JA)
 ■ For North American model only (US)
 * For German/France model only (E1)
 * For Canada/France model only (T-03E3)
 * For West Germany model only (T-117L, S04)
 * For West Germany model only (T-03L, S01)
 Others *Common

Figure 21
<21 [] >

Block Diagram

(SD/EK/UZ Model1)

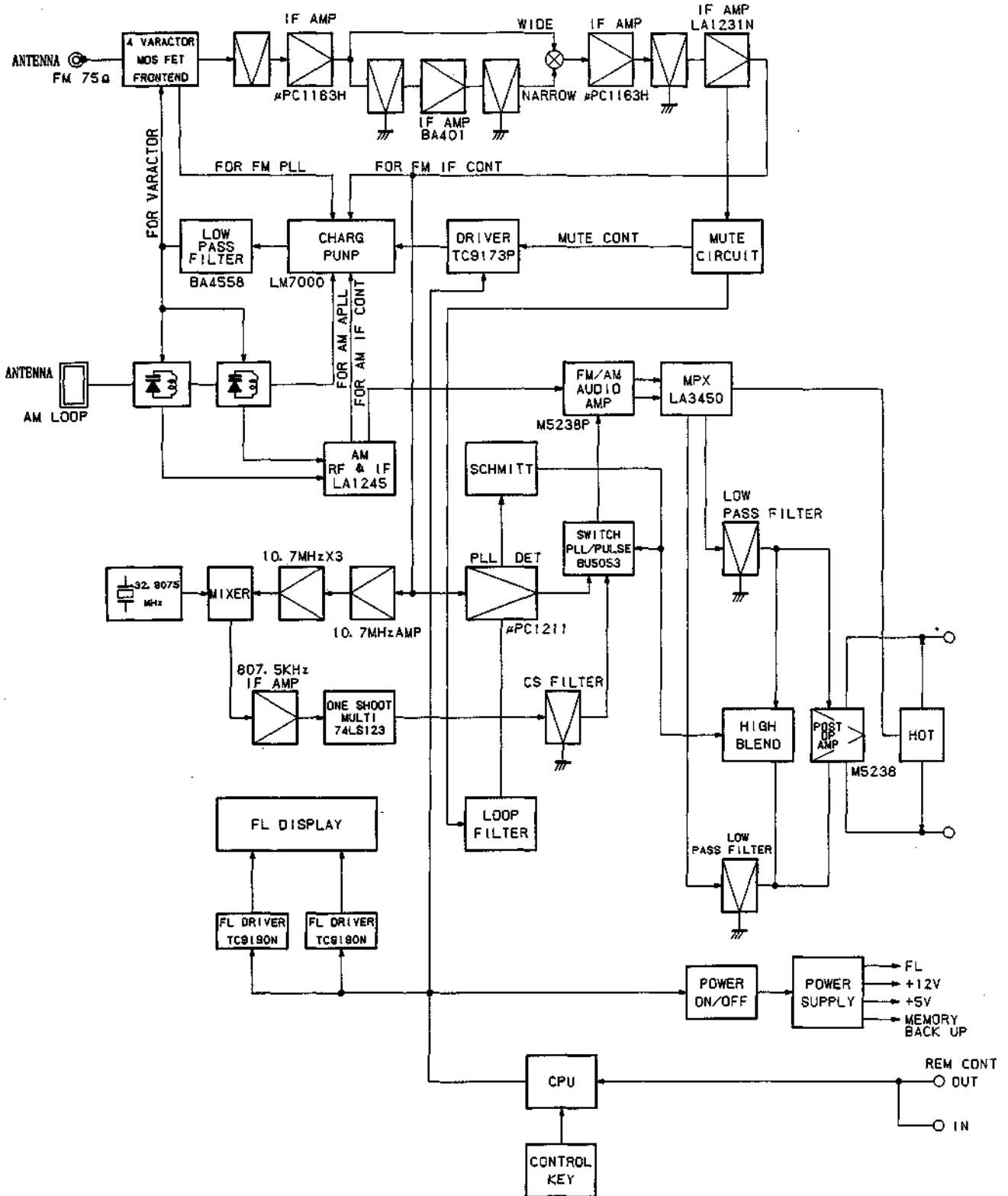

Block Diagram

(JA Model Only)

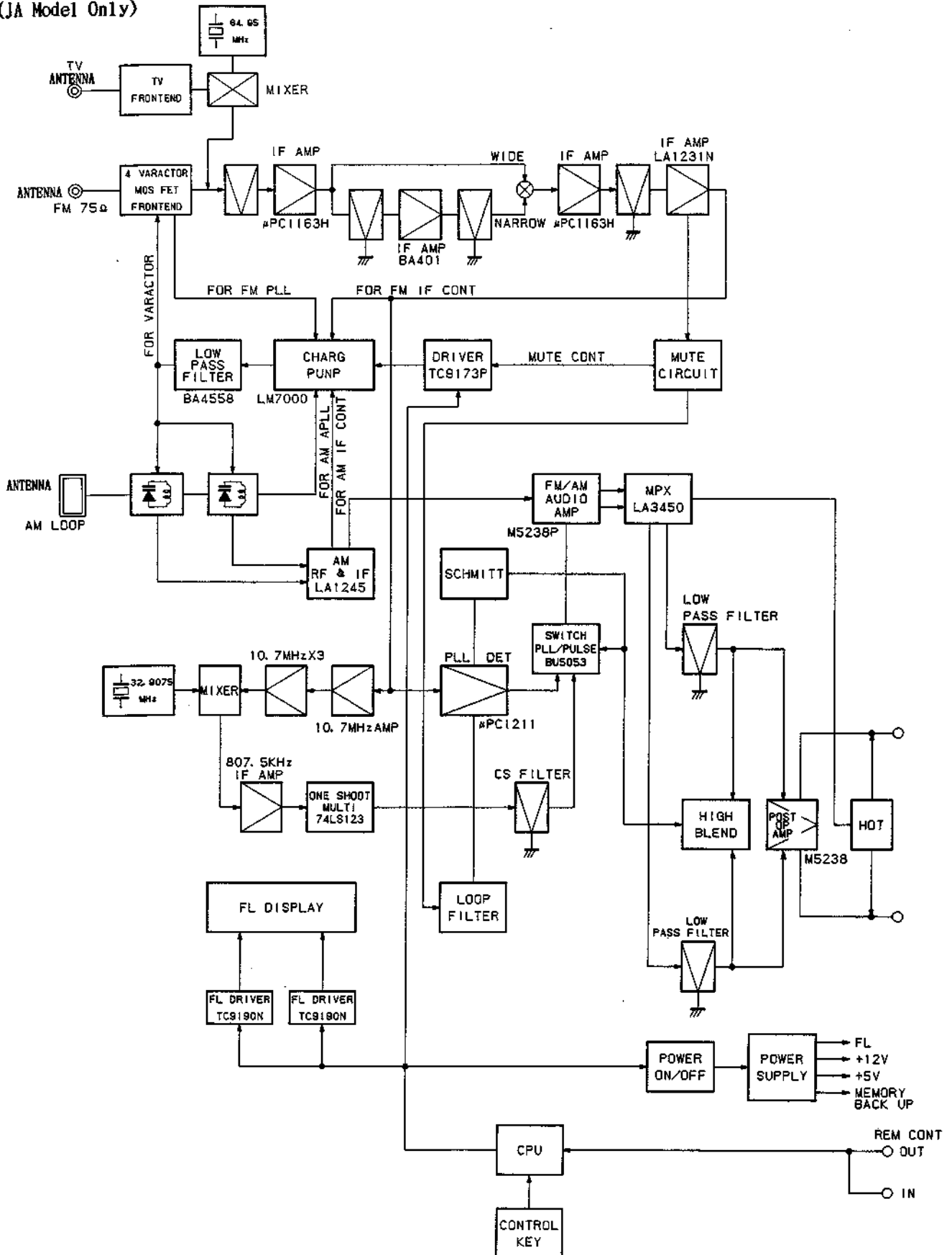

FM Tuner Schematic Diagram

FM TUNER(EK, UZ Model only)

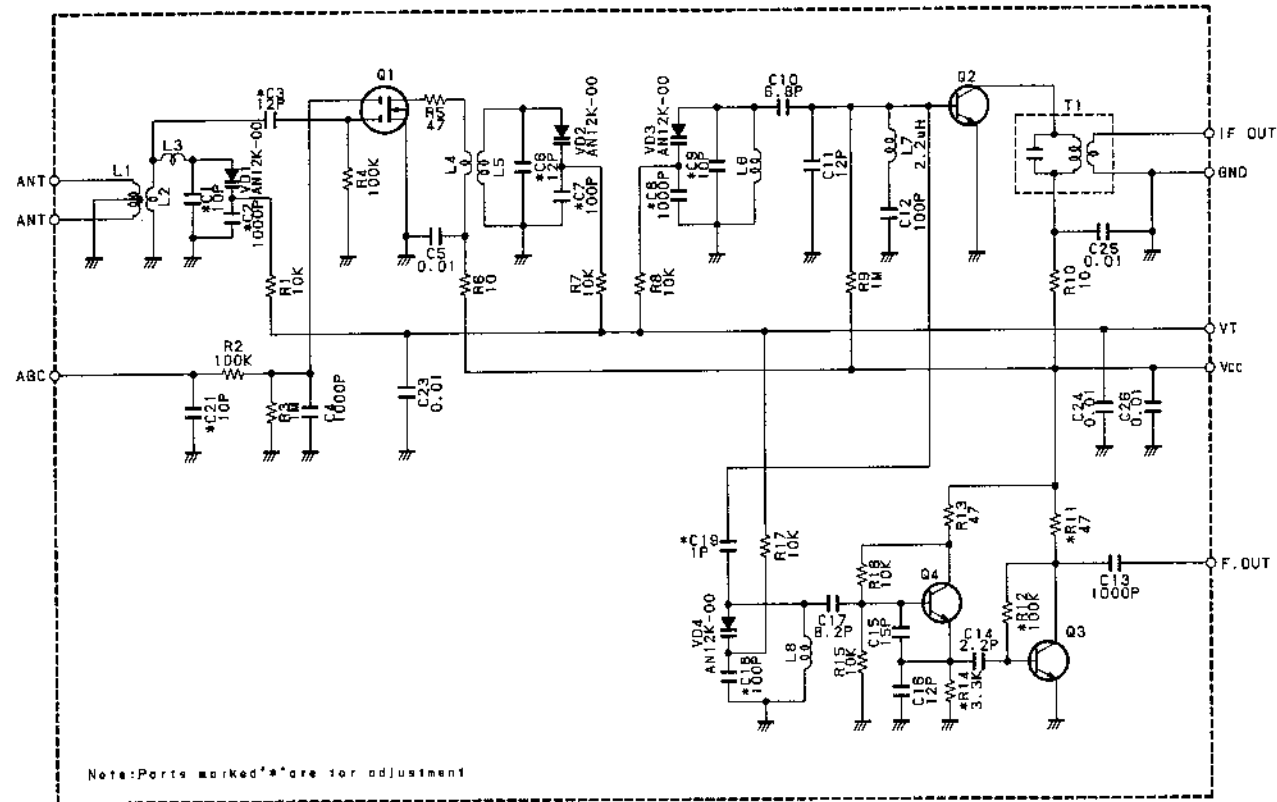

FM チューナー(JA Model only)

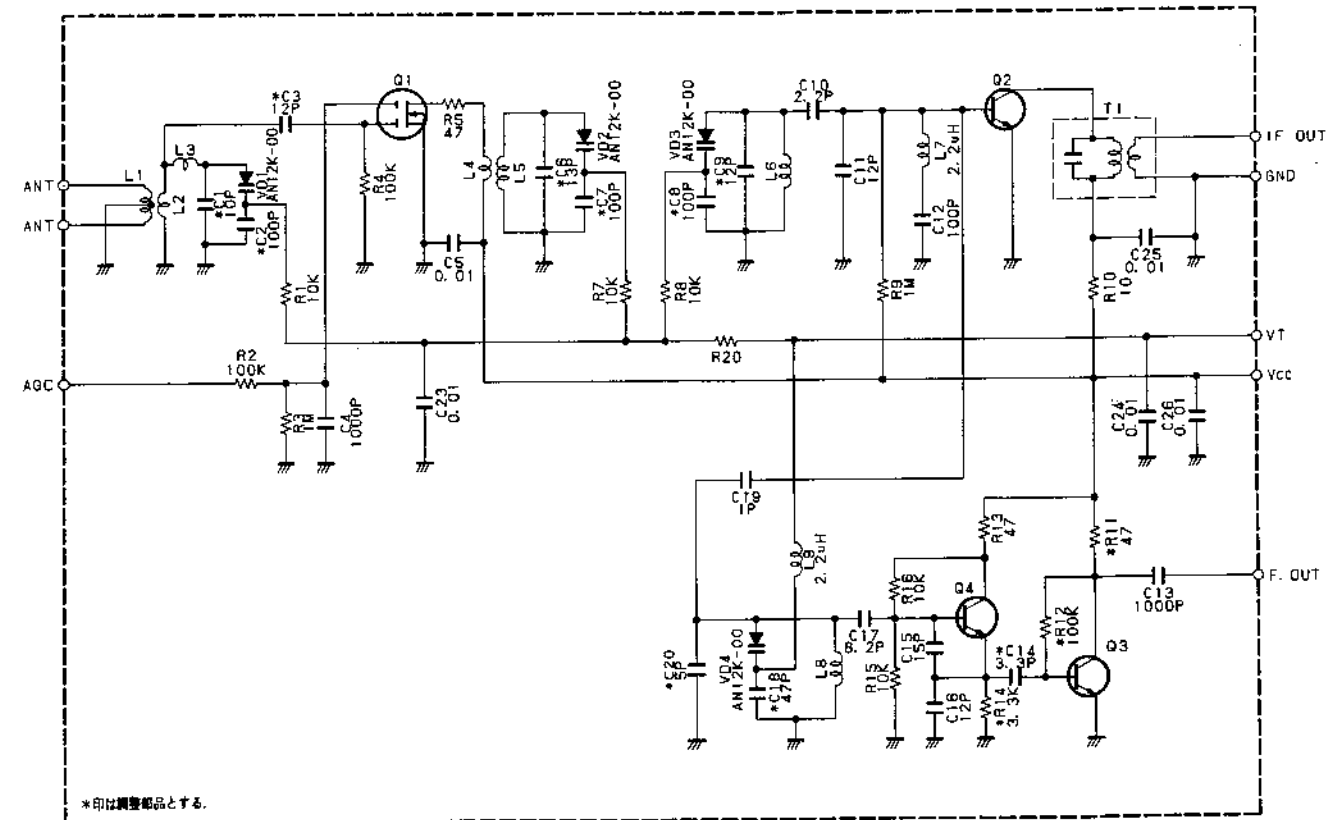

FM TUNER(SD Model only)

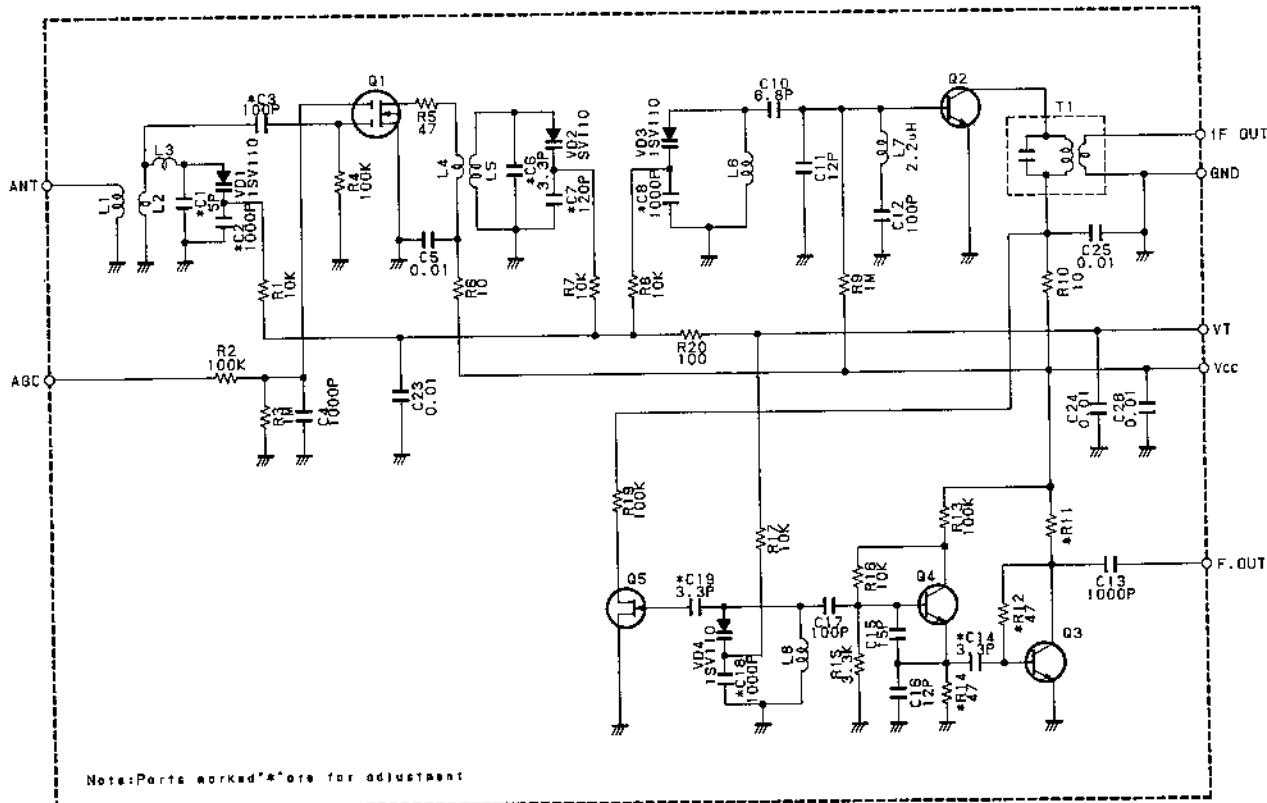

T-117/T-117L
T-03/T-03L

TV Tuner Schematic Diagram (JA model only)

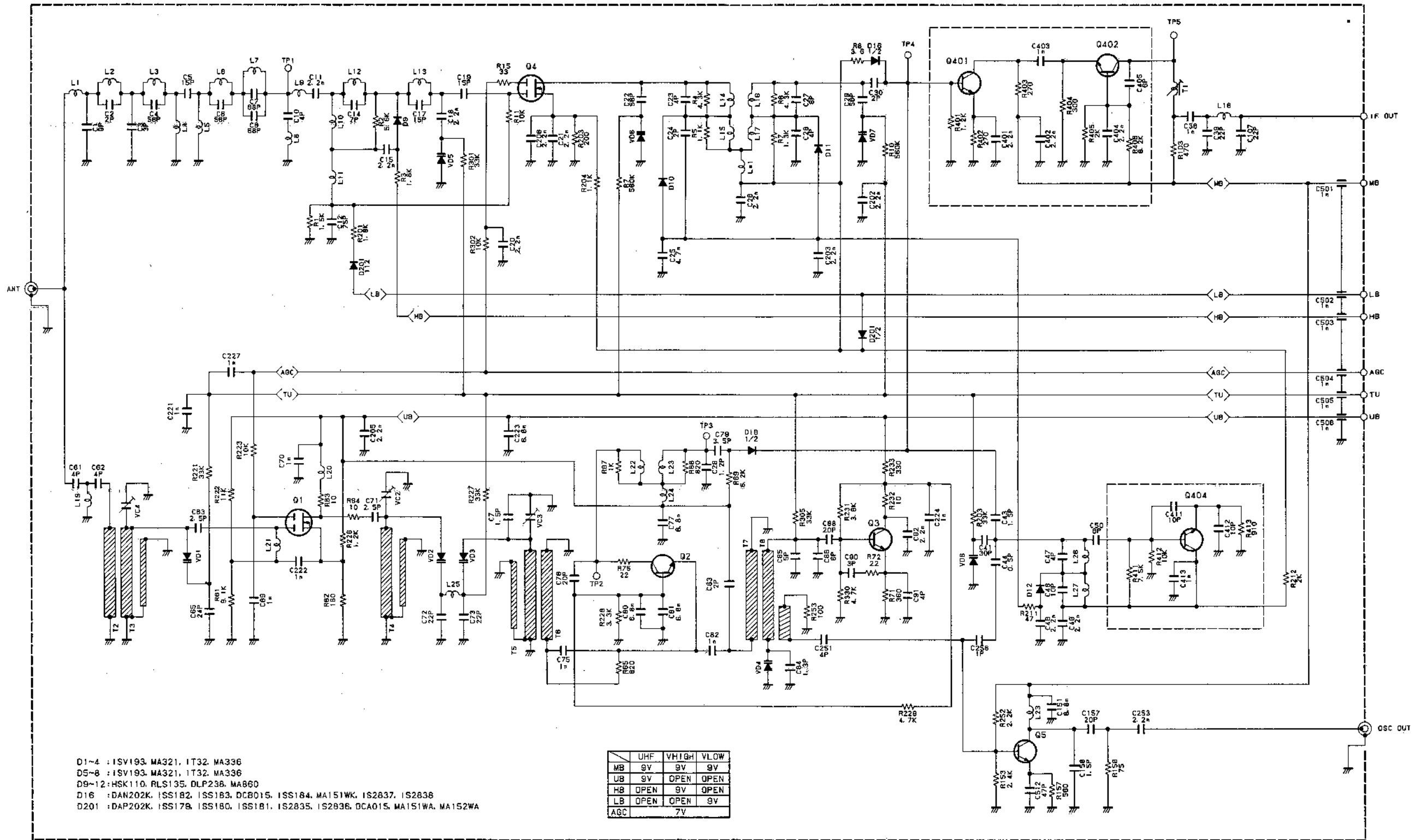

Schematic Diagram Switch, Display (1/3)

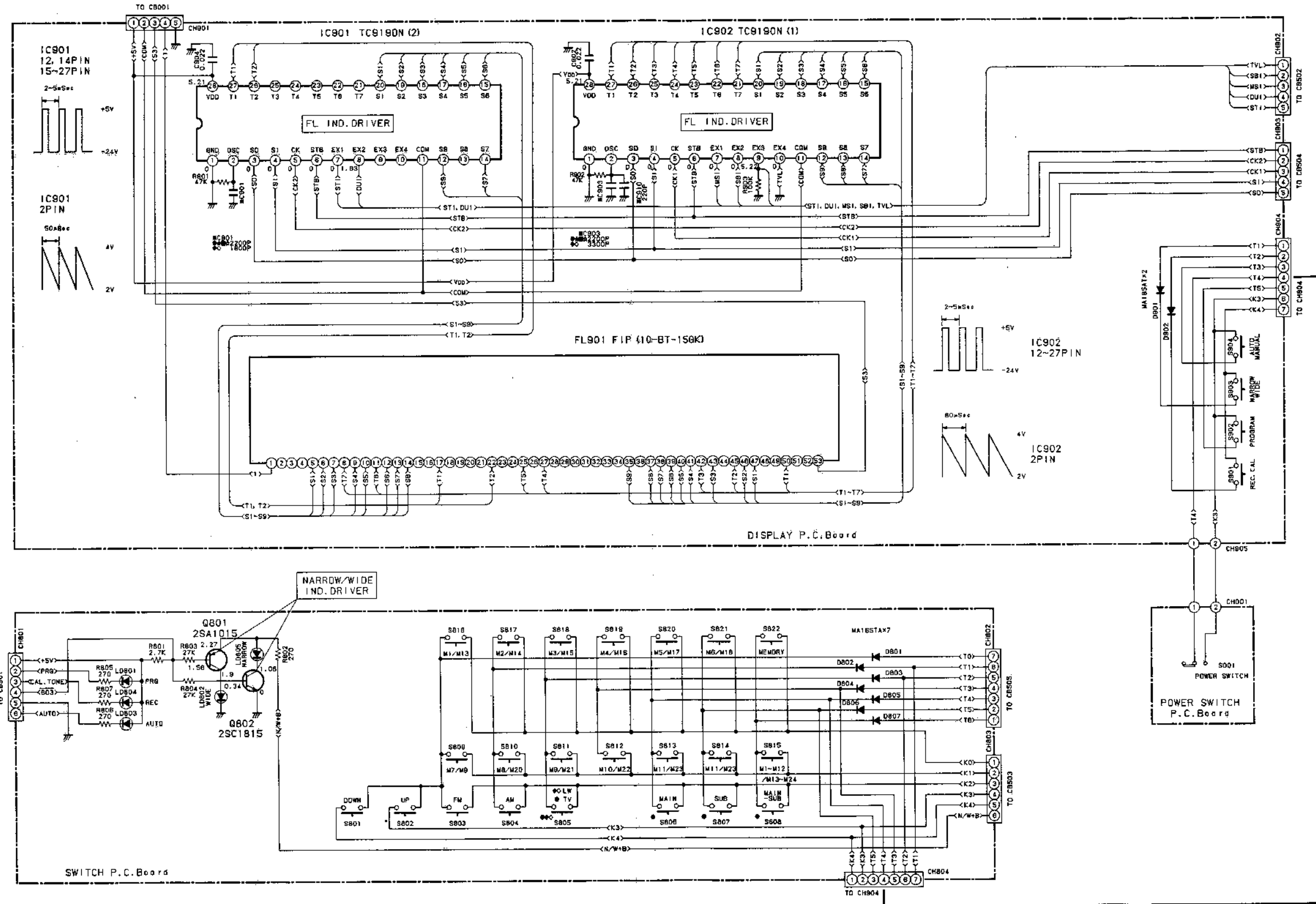

- : For Japanese model only (JA)
- ★ : For General Foreign model only (EK)
- ☆ : For General Foreign model only (T-03 EK)
- : For North American model only (UZ)
- ◆ : For West Germany model only (T-117L SD)
- ◇ : For West Germany model only (T-03L SD)
- Others : Common

T-117/T-117L
T-03/T-03L

Schematic Diagram Main (2/3) (JA model)

IC	IC001	IC001	IC101	IC104	IC102	IC501	IC201	IC202	IC401	IC203	IC402			
Transistor (Q)	Q302	Q303	Q118	Q008	Q008	Q003	Q201	Q112	Q205	Q206	Q212	Q213	Q208	Q209
	Q1002	Q1001	Q004	Q007	Q010	Q001	Q108	Q115	Q113	Q207	Q214	Q210		

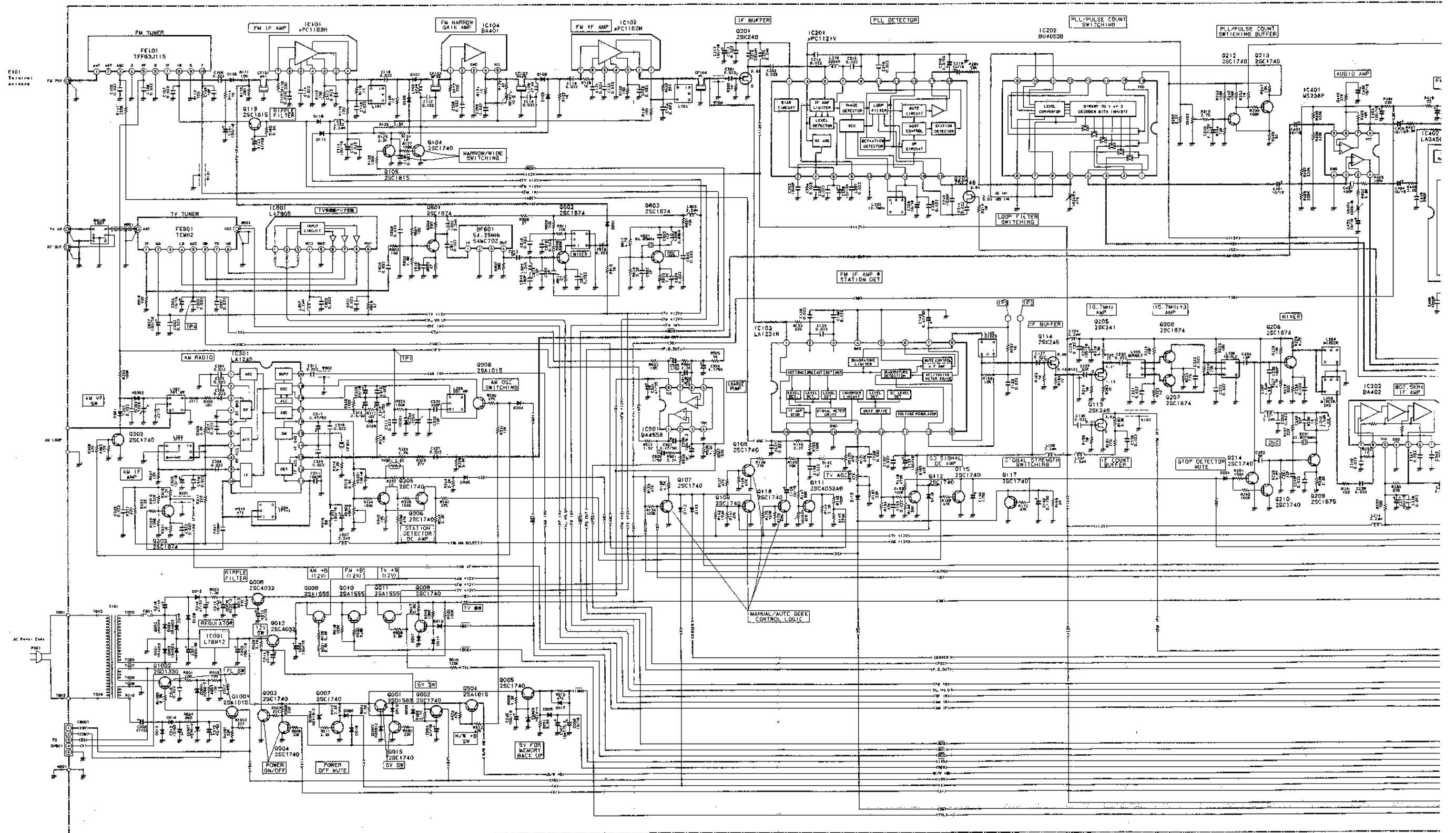

IC401 IC203 IC402 IC204 IC701 IC404 IC502 IC503 IC506 IC504 IC505 IC507 Q118 Q501 Q505 Q509 Q403 Q402 Q409 Q404 Q408 Q407 Q405 Q411 Q410 Q406 Q211 Q210 Q209 Q208

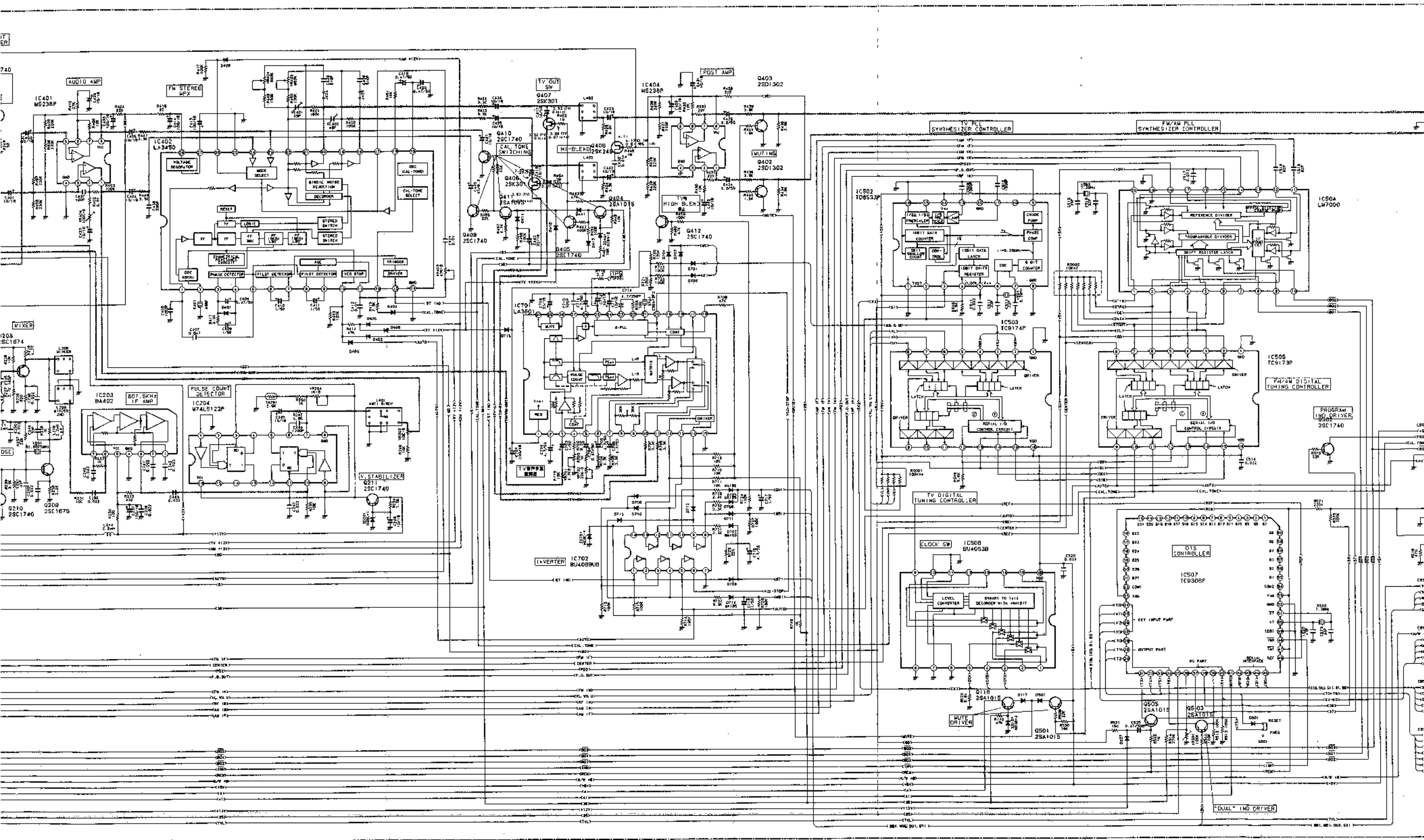

T-117

Schematic Diagram Main (3/3) (EK/SD/UZ model)

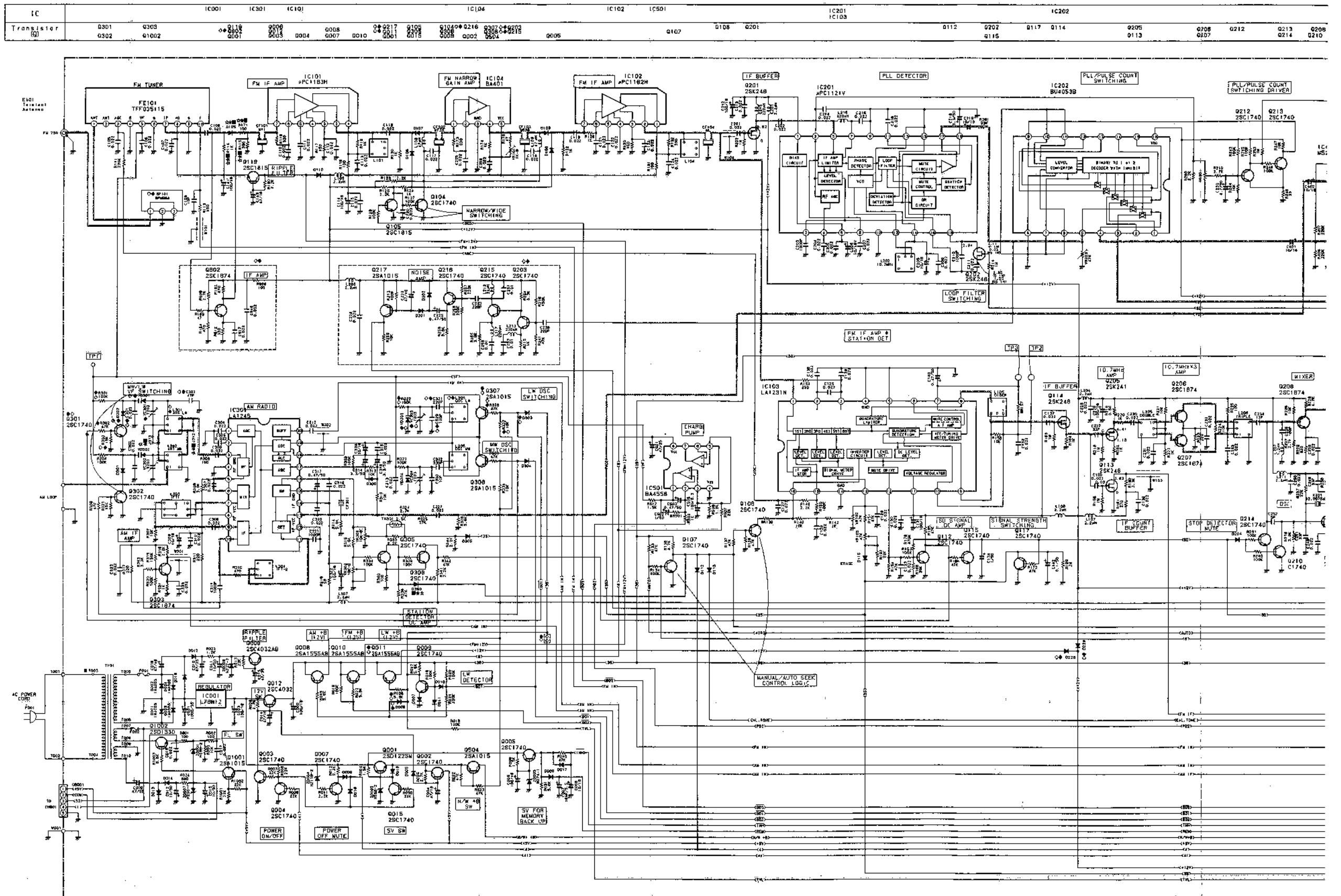

#1: Not Used

Part No.	Value	Part No.	Value	Part No.	Value
R157	2.2Kohm	10Kohm			
R130	30Kohm	22Kohm			
R501	2.2Kohm	10Kohm			
C428	510P	510P			
C429	510P	510P			

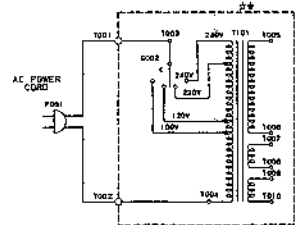
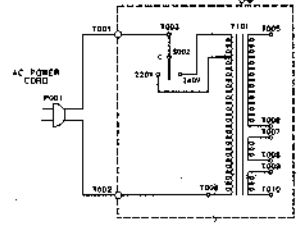

IC401 IC203 IC402 IC204 IC404 IC504 IC505 IC506 IC507 DS02 DS10

Q206 Q207 Q212 Q213 Q214 Q208 Q210 Q209 Q211 Q401 Q408 Q411 Q404 Q405 Q418 Q501 Q402 DS05 DS03

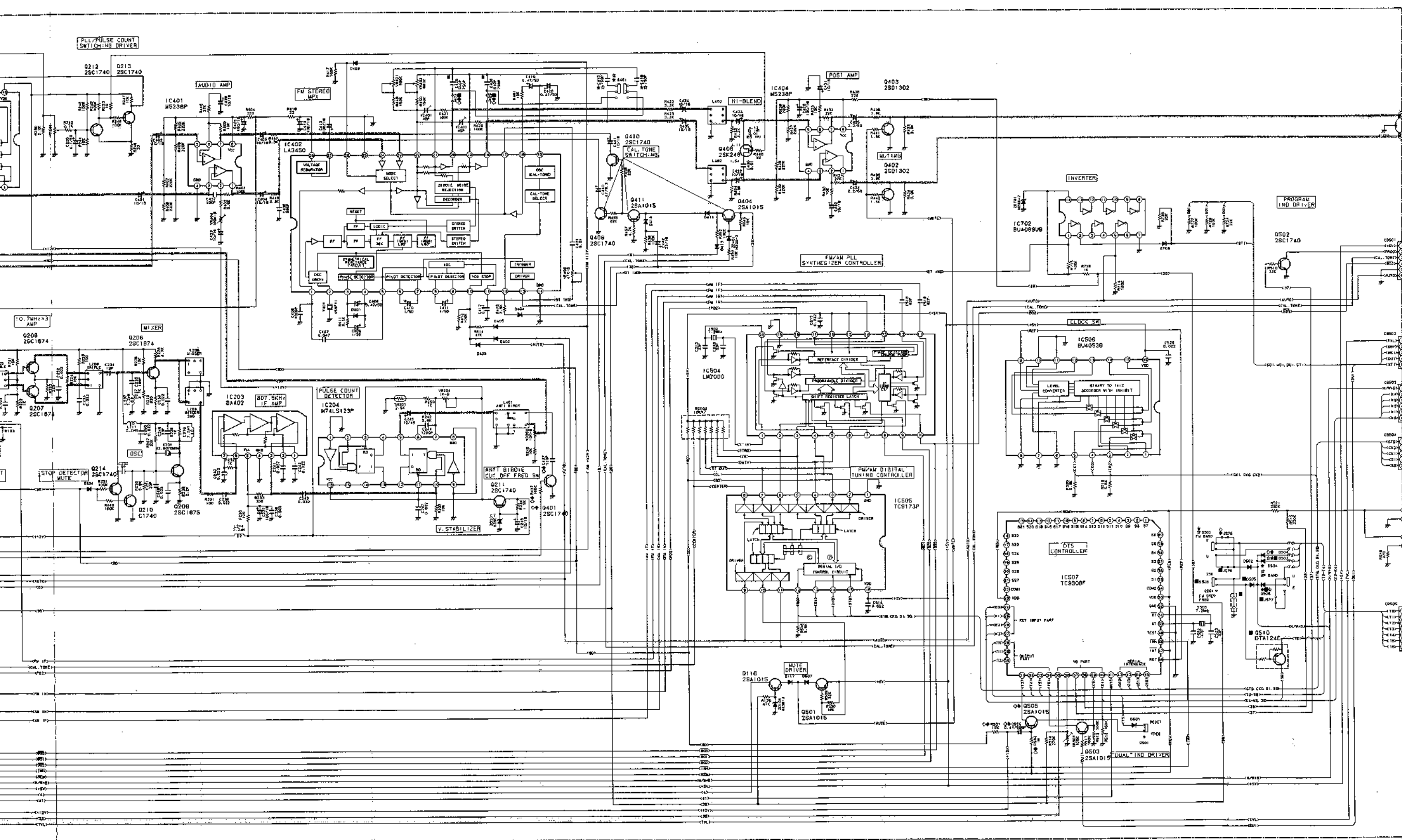

★ : For General Foreign model only (EK) ■ : For North American model only (UZ) ◆ : For West Germany model only (T-117L SD)
 ☆ : For General Foreign model only (T-03 EK) ◇ : For West Germany model only (T-08L SD) Others: Common

**T-117L, T-03/
T-03L**

Parts Lagout on P.C. Boards and Wiring Diagram

SWITCH P.C. Board/DISPLAY P.C. Board/POWER SWITCH P.C.Board /FL SWITCH P.C.Board (JA Model only)

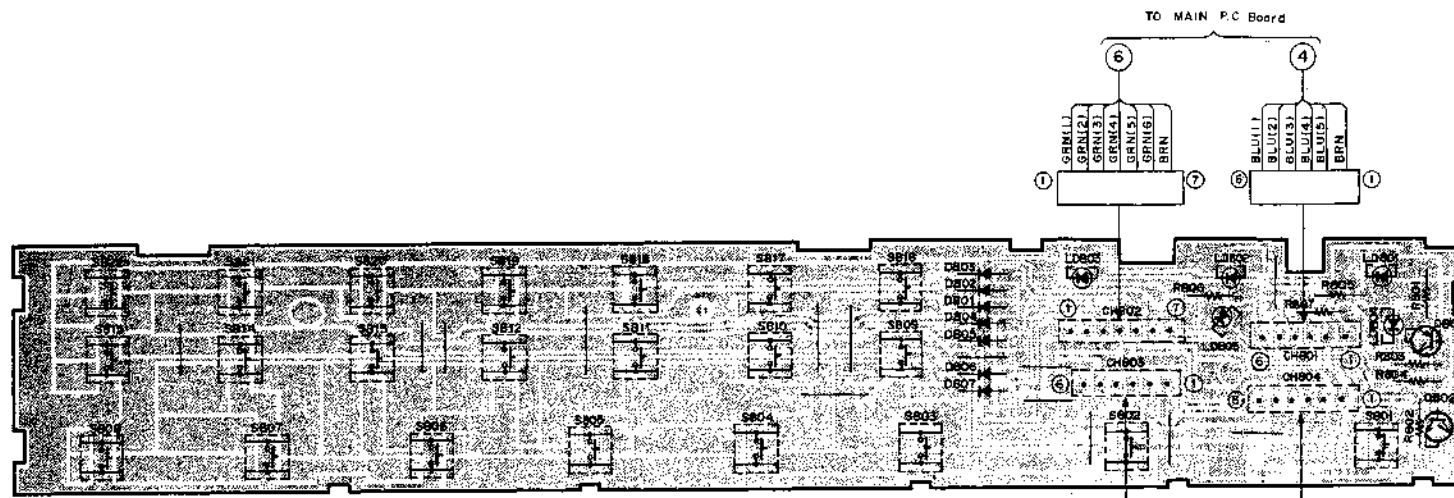

SWITCH P.C. Board

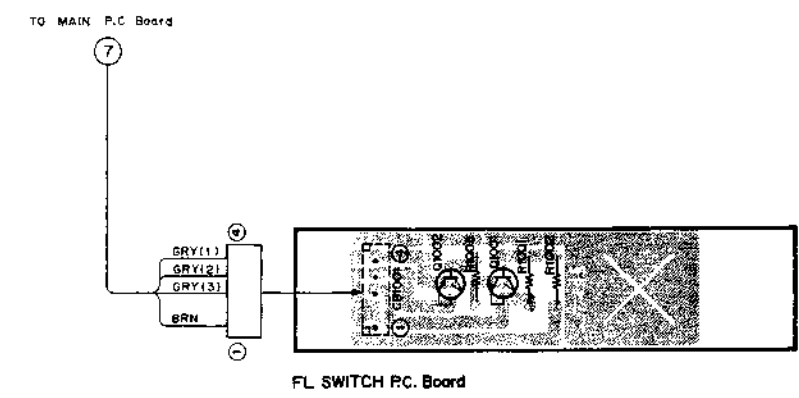

FL SWITCH P.C. Board

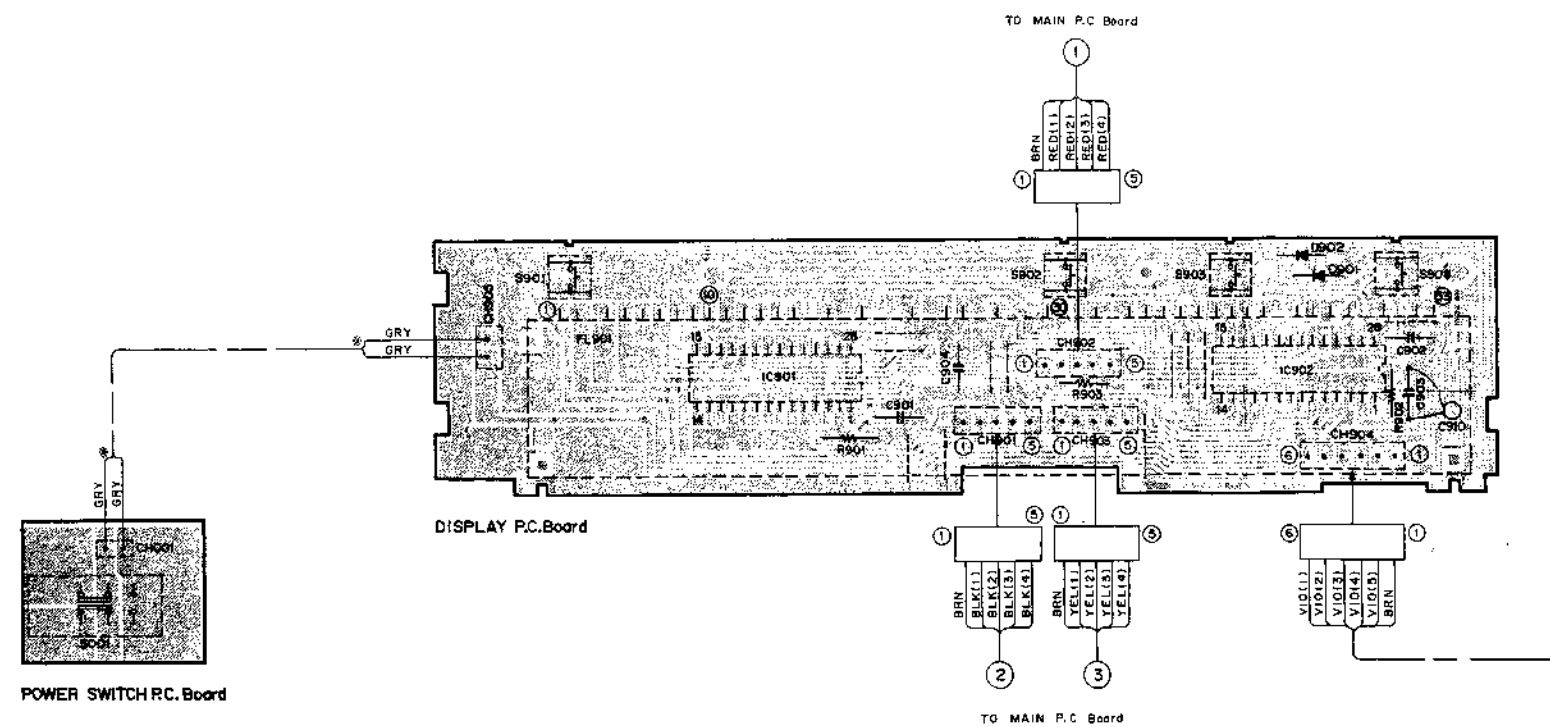

DISPLAY P.C. Board

POWER SWITCH P.C. Board

SWITCH P.C. Board/DISPLAY P.C. Board/POWER SWITCH P.C.Board /FL SWITCH P.C.Board (EK/SD/UZ Model only)

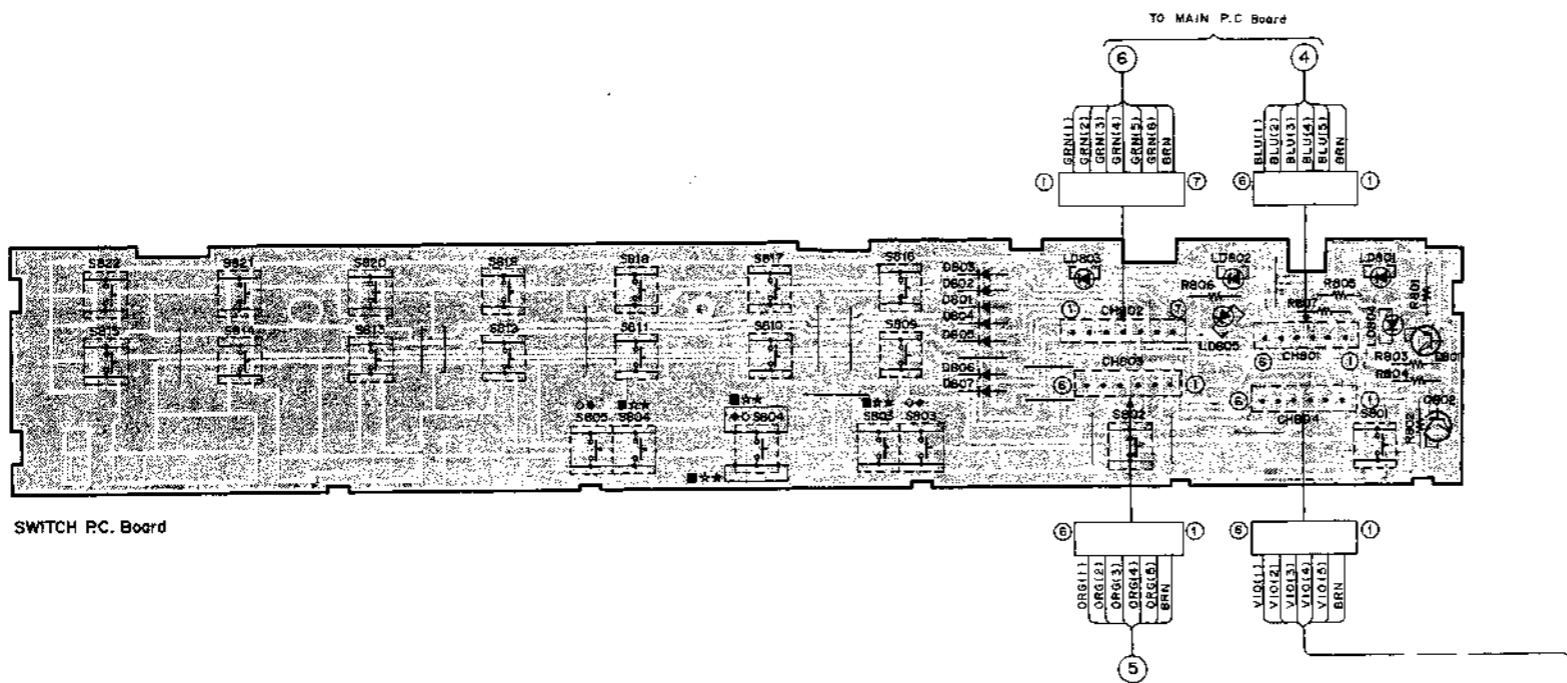

SWITCH P.C. Board

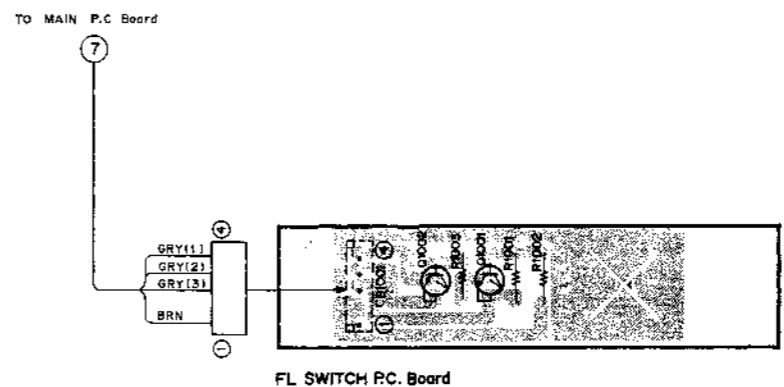

FL SWITCH P.C. Board

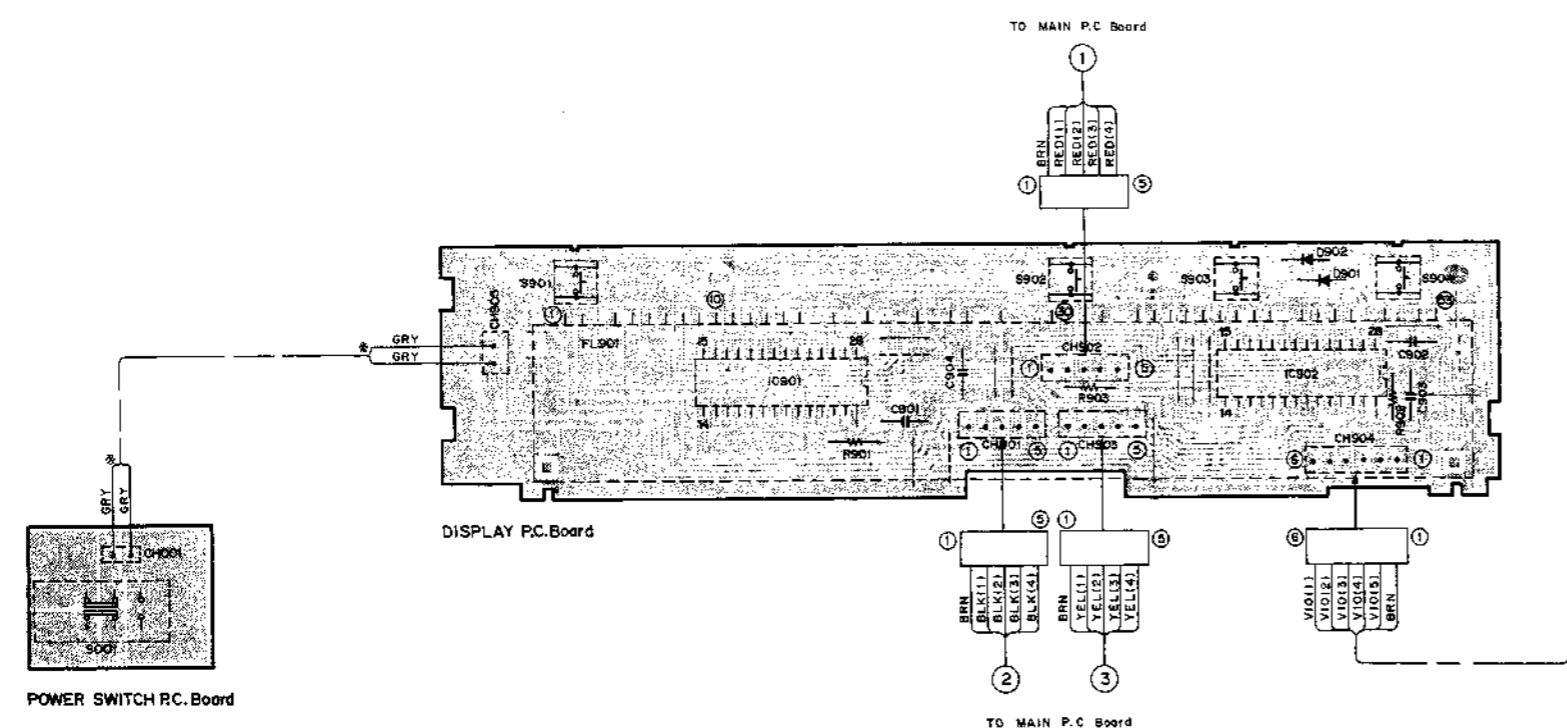

DISPLAY P.C. Board

POWER SWITCH P.C. Board

MAIN P.C. Board (JA Model only)

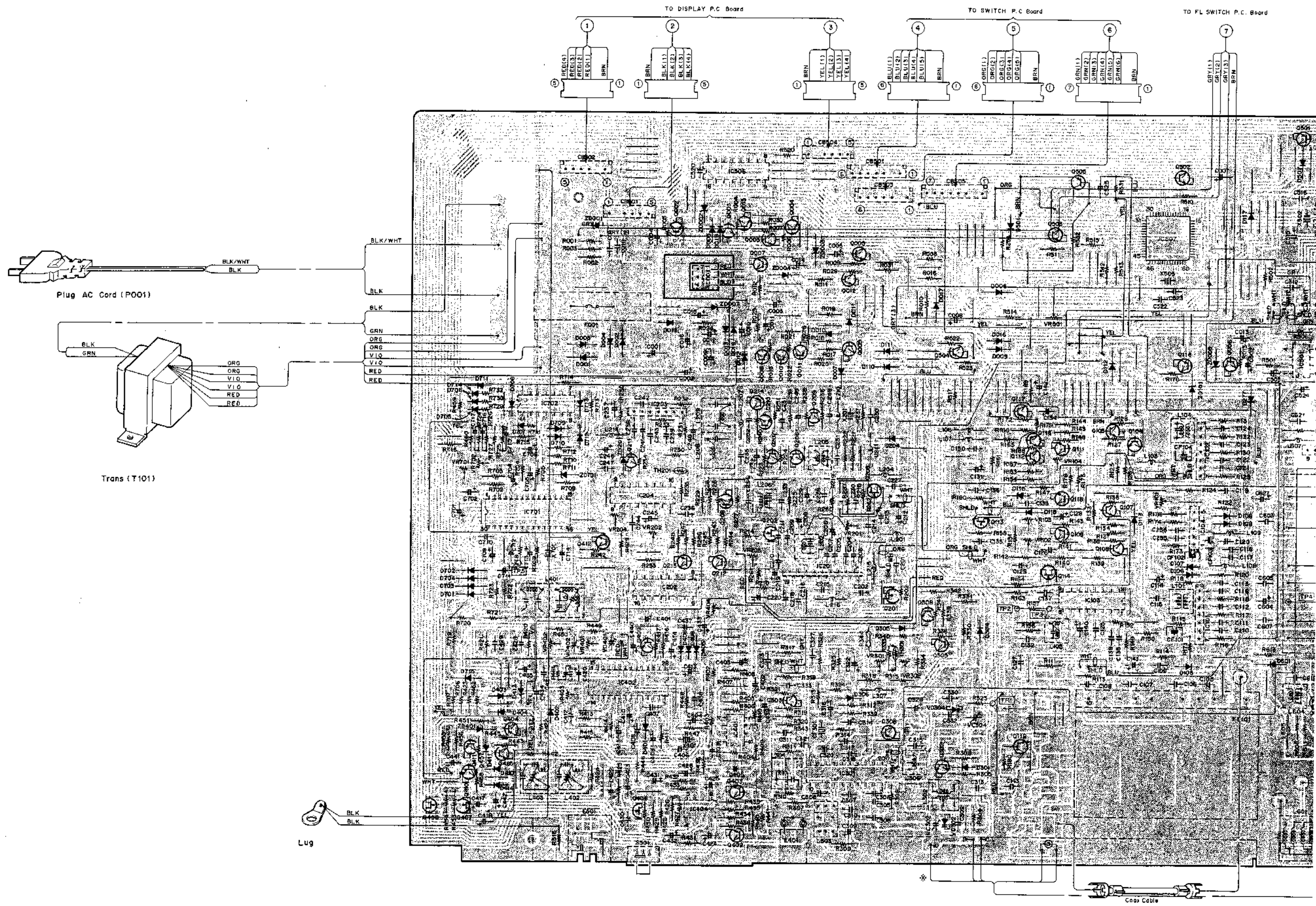

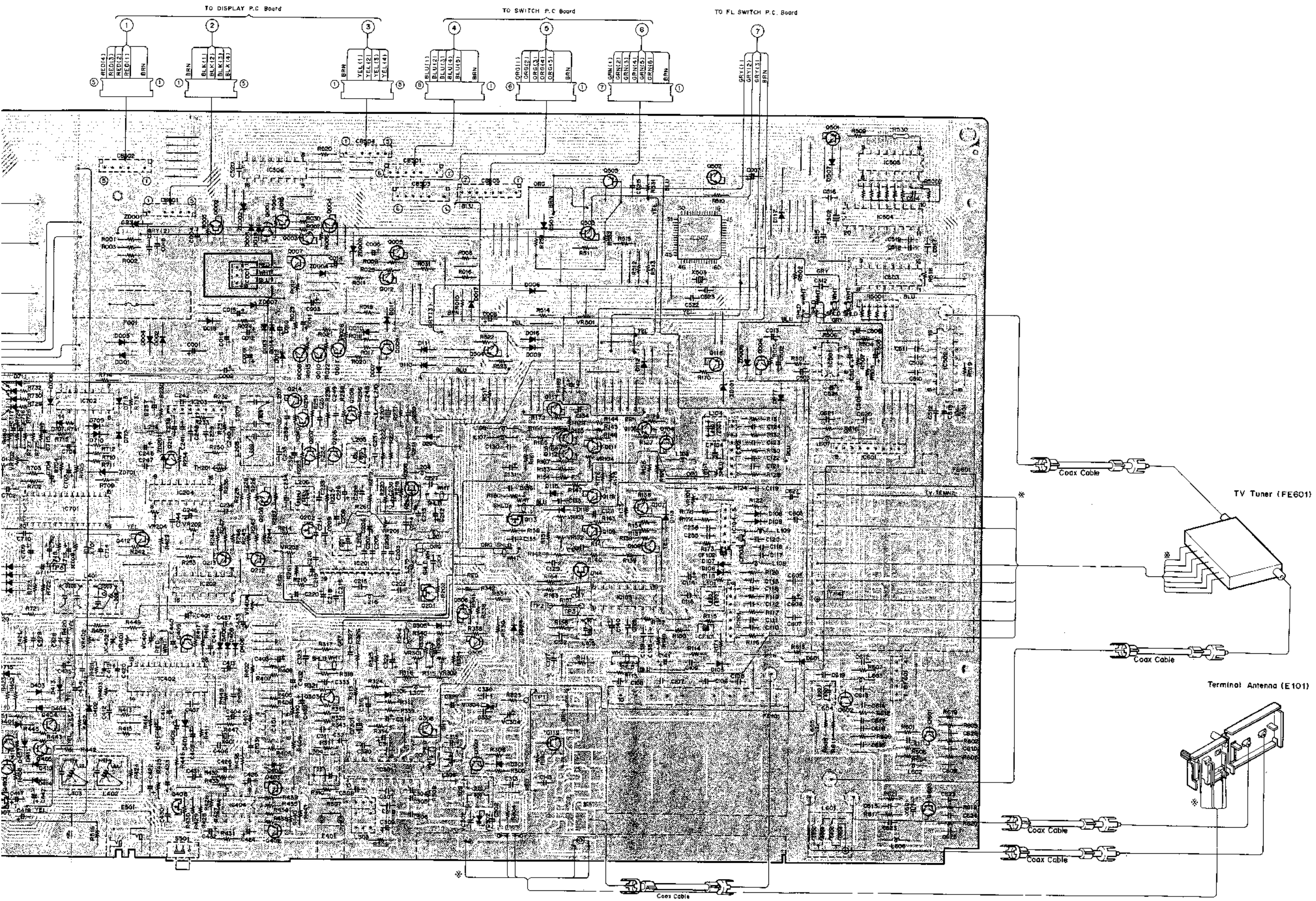

MAIN P.C. Board (EK/SD/UZ Model only)

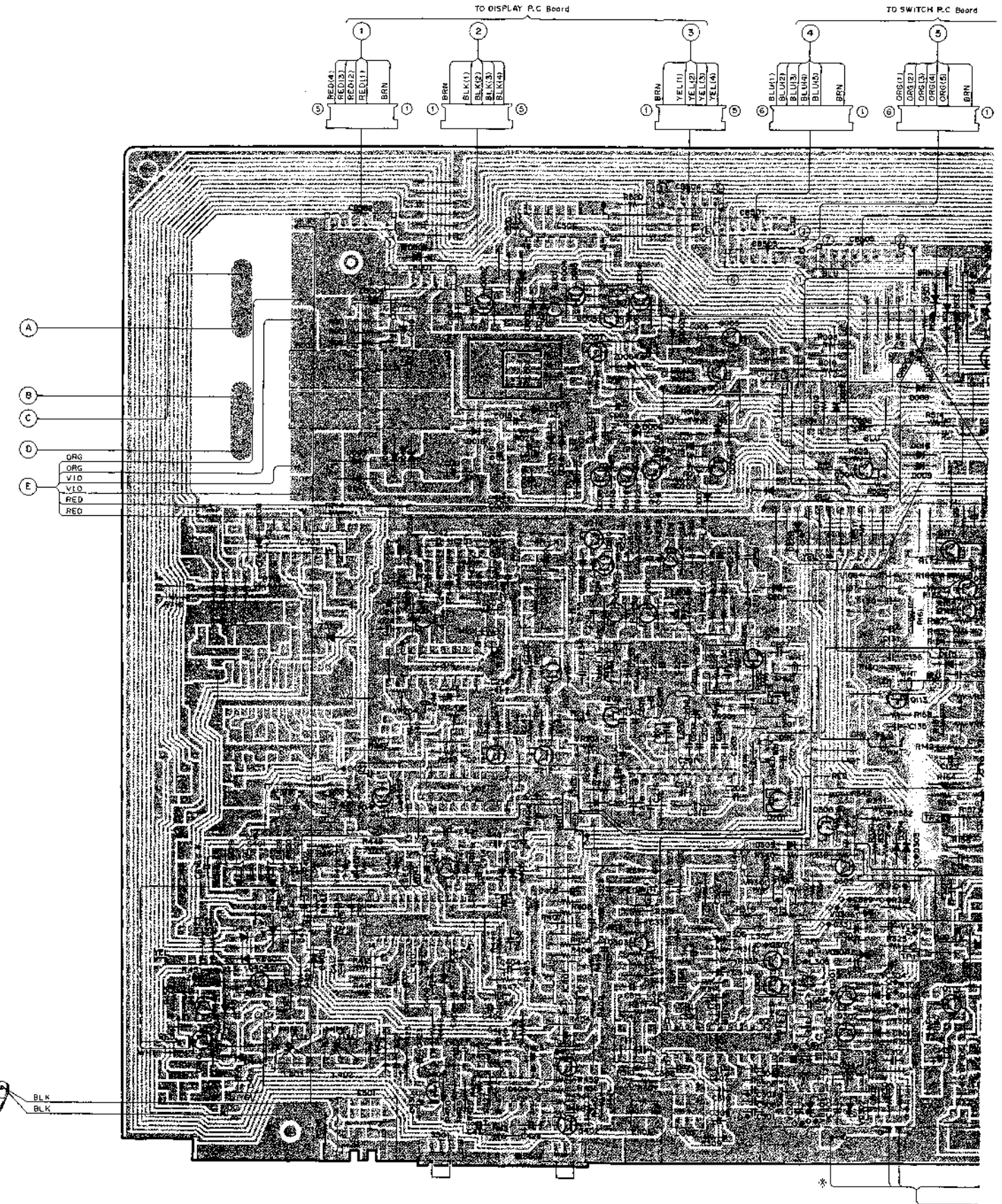
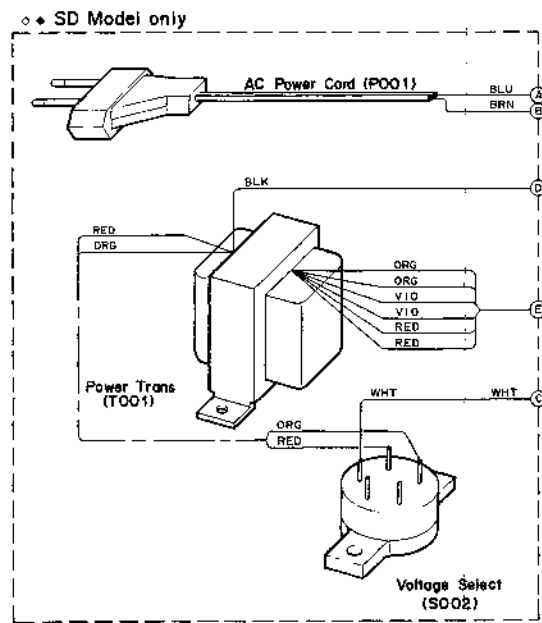
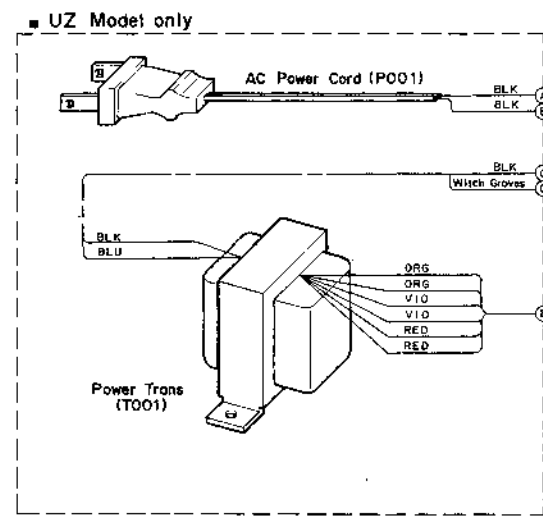
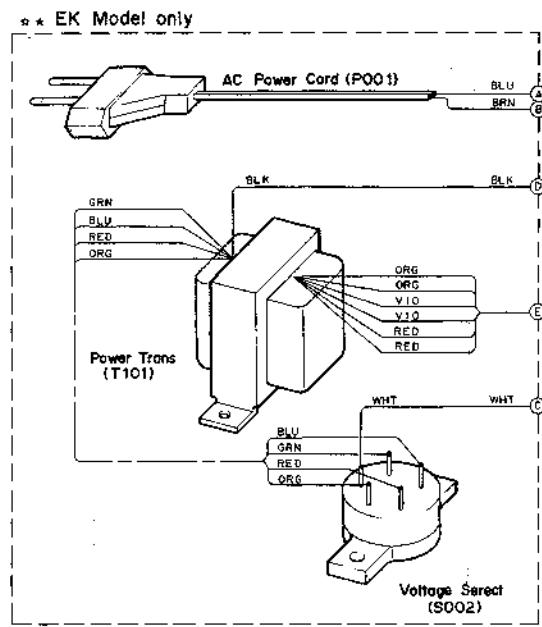

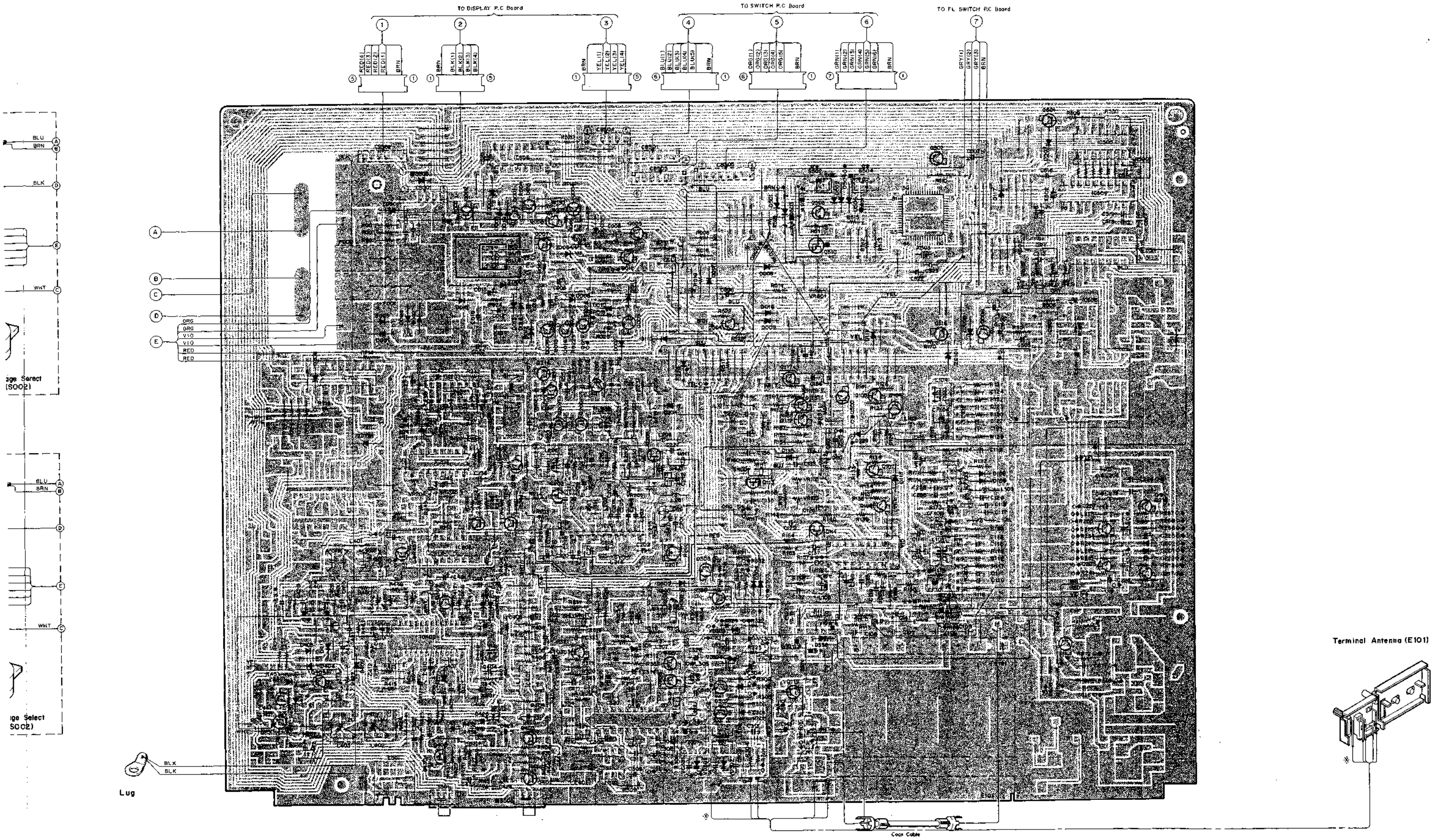

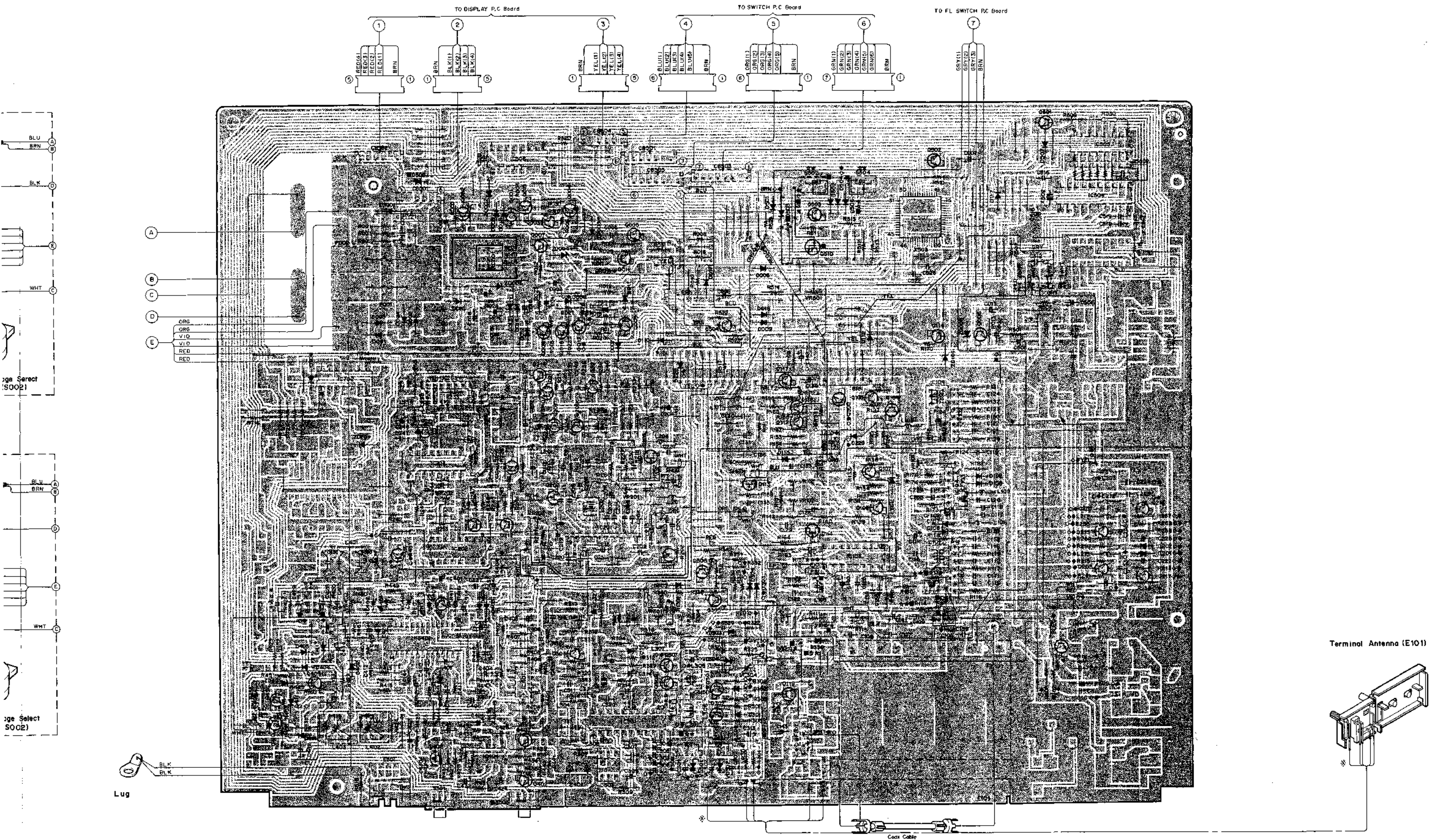

Electrical Parts List

Resistor: Carbon resistors under 1/4 watts are not mentioned in the parts list, please confirm them by schematic diagram.
 μ F=microfarads. pF=picofarads

Abbreviations			Symbol No.	Part No.	Description
RES.-Resistor	PP.-Polypropylene		Q004	48T81103F01	2SC1740
CER.-Ceramic	MYL.-Mylar		or	48T81101F01	2SC1815
CAP.-Capcitor	ELY.-Electrolytic		Q005	48T81103F01	2SC1740
TR.-TransistoR	POLY.-Polystrol		or	48T81101F01	2SC1815
			Q006	48T82761F01	2SC4032AB
			Q007	48T81103F01	2SC1740
			or	48T81101F01	2SC1815
			Q008	48T82910F01	2SA1555AB
			Q009	48T81103F01	2SC1740
			or	48T81101F01	2SC1815
			Q010	48T82910F01	2SA1555AB
			Q011	48T82910F01	2SA1555AB
			Q011	48T82910F01	2SA1555AB
			Q011	48T82910F01	2SA1555AB
			Q012	48T82761F01	2SC4032AB
			Q015	48T81103F01	2SC1740
			or	48T81101F01	2SC1815
			Q104	48T81103F01	2SC1740
			Q105	48T81103F01	2SC1740
			Q107	48T81103F01	2SC1740
			Q108	48T81103F01	2SC1740
			Q109	48T81103F01	2SC1740
			or	48T81101F01	2SC1815
			Q111	48T82761F01	2SC4032AB
			Q112	48T81103F01	2SC1740
			or	48T81101F01	2SC1815
			Q113	48T86948F01	FET. 2SK246
			Q114	48T86948F01	FET. 2SK246
			Q115	48T81103F01	2SC1740
			or	48T81101F01	2SC1815
			Q116	48T81102F01	2SA1015
			or	48T81104F01	2SA983A
			Q117	48T81103F01	2SC1740
			or	48T81101F01	2SC1815
			Q118	48T81103F01	2SC1740
			or	48T81101F01	2SC1815
			Q119	48T81101F01	2SC1815
			Q201	48T86948F01	FET. 2SK246
			Q202	48T86948F01	FET. 2SK246
			Q203	48T81103F01	2SC1740
			or	48T81101F01	2SC1815
			Q203	48T81103F01	2SC1740
			or	48T81101F01	2SC1815
			Q205	48T83926F03	2SK241
			Q206	48S40732P02	2SC1674
			Q207	48S40732P02	2SC1674
			Q208	48S40732P02	2SC1674
			Q209	48S44580J03	2SC1675

Main P.C. Board		
IC's		
IC001	51T86583F07	L78N12
IC101	51T84601F01	μ PC1183H
IC102	51T84601F01	μ PC1183H
IC103	51T50885F01	LA1231N
IC104	51T72216F01	BA401
IC201	51T84606F01	μ PC1211V
IC202	51T89181F01	BU4053B
IC203	51T62863F01	BA402
IC204	51T56594F01	M74LS123P
IC301	51T53323F01	LA1245
IC401	51T80136F01	M5238P
IC402	51T84610F01	LA3450
IC404	51T80136F01	M5238P
IC501	51T85380F01	BA4558
IC502	51T84659F01	TD8352P
IC503	51T84657F01	TC9174P
IC504	51T84660F01	LM7000
IC505	51T84658F01	TC9173P
IC506	51T89181F01	BU4053B
IC507	51T92066F01	TC9306F
IC601	51T84694F01	LA7905
IC701	51T84611F01	LA3801
IC702	51T68998F01	BU4069UB
Transistors		
Q001	48T90204F03	2SD1563
Q001	48T83085F01	2SD1225M
Q001	48T83085F01	2SD1225M
Q001	48T83085F01	2SD1225M
Q001	48T83085F01	2SD1225M
Q001	48T83085F01	2SD1225M
Q002	48T81103F01	2SC1740
or	48T81101F01	2SC1815
Q003	48T81103F01	2SC1740
or	48T81101F01	2SC1815

Note: ● : For Japanese model only (JA) ■ : For North American model only (UZ)
 ★ : For General Foreign model only (EK) ◆ : For West Germany model only (T-117L SD)
 ☆ : For General Foreign model only (T-03 EK) ◇ : For West Germany model only (T-03L SD) Others : Common

Symbol No.	Part No.	Description	Symbol No.	Part No.	Description
Q210	48T81103F01	2SC1740	Q403	48T57305F01	2SD1302
or	48T81101F01	2SC1815	Q404	48T81102F01	2SA1015
Q211	48T81108F01	2SC1740	or	48T81104F01	2SA933A
or	48T81101F01	2SC1815	● Q405	48T81103F01	2SC1740
Q212	48T81108F01	2SC1740	● or	48T81101F01	2SC1815
or	48T81101F01	2SC1815	Q406	48T66948F01	FET. 2SK246
Q213	48T81103F01	2SC1740	● Q407	48T52122F02	FET. 2SK301
or	48T81101F01	2SC1815	● Q408	48T52122F02	FET. 2SK301
Q214	48T81108F01	2SC1740	Q409	48T57305F01	2SD1302
or	48T81101F01	2SC1815	Q410	48T81103F01	2SC1740
◇ Q215	48T81108F01	2SC1740	or	48T81101F01	2SC1815
◇ or	48T81101F01	2SC1815	Q411	48T81102F01	2SA1015
◆ Q215	48T81103F01	2SC1740	or	48T81104F01	2SA933A
◆ or	48T81101F01	2SC1815	● Q412	48T81103F01	2SC1740
◆ Q216	48T81108F01	2SC1740	● or	48T81101F01	2SC1815
◆ or	48T81101F01	2SC1815	Q501	48T81102F01	2SA1015
◇ Q216	48T81103F01	2SC1740	or	48T81104F01	2SA933A
◇ or	48T81101F01	2SC1815	Q502	48T81103F01	2SC1740
◆ Q217	48T81102F01	2SA1015	or	48T81101F01	2SC1815
◆ or	48T81104F01	2SA933A	Q503	48T81102F01	2SA1015
◇ Q217	48T81102F01	2SA1015	or	48T81104F01	2SA933A
◇ or	48T81104F01	2SA933A	Q504	48T81102F01	2SA1015
◆ Q301	48T81103F01	2SC1740	or	48T81104F01	2SA933A
◆ or	48T81101F01	2SC1815	● Q505	48T81102F01	2SA1015
◇ Q301	48T81103F01	2SC1740	◇ Q505	48T81102F01	2SA1015
◇ or	48T81101F01	2SC1815	◆ Q505	48T81102F01	2SA1015
Q302	48T81103F01	2SC1740	■ Q510	48T62964F03	DTA124E
or	48T81101F01	2SC1815	● Q601	48S40732P02	2SC1674
Q303	48S40732P02	2SC1674	● Q602	48S40732P02	2SC1674
Q305	48T81103F01	2SC1740	◆ Q602	48S40732P02	2SC1674
or	48T81101F01	2SC1815	◇ Q602	48S40732P02	2SC1674
Q306	48T81103F01	2SC1740	● Q603	48S44580J03	2SC1675
or	48T81101F01	2SC1815	Diodes		
◆ Q307	48T81102F01	2SA1015	D001	48S40477U01	1N4003
◆ or	48T81104F01	2SA933A	D002	48S40477U01	1N4003
◇ Q307	48T81102F01	2SA1015	D003	48S40477U01	1N4003
◇ or	48T81104F01	2SA933A	D004	48S40477U01	1N4003
Q308	48T81102F01	2SA1015	D005	48T44813F01	MA1657A
or	48T81104F01	2SA933A	D006	48T44813F01	MA1657A
◆ Q401	48T81103F01	2SC1740	D007	48T44813F01	MA1657A
◆ or	48T81101F01	2SC1815	◆ D008	48T44813F01	MA1657A
◇ Q401	48T81103F01	2SC1740	◇ D008	48T44813F01	MA1657A
◇ or	48T81101F01	2SC1815	D009	48T44813F01	MA1657A
Q402	48T57305F01	2SD1302			

Note: ● : For Japanese model only (JA) ■ : For North American model only (UZ)
★ : For General Foreign model only (EK) ◆ : For West Germany model only (T-117L SD)
☆ : For General Foreign model only (T-03 EK) ◇ : For West Germany model only (T-03L SD) Others : Common

Symbol No.	Part No.	Description			Symbol No.	Part No.	Description		
	D010	48T44813F01	MA165TA			D402	48T44813F01	MA165TA	
	D011	48T44813F01	MA165TA			D403	48T44813F01	MA165TA	
	D012	48T44813F01	MA165TA			D404	48T44813F01	MA165TA	
	D013	48T44813F01	MA165TA			D405	48T44813F01	MA165TA	
	D014	48T44813F01	MA165TA			● D406	48T44813F01	MA165TA	
	D016	48T44813F01	MA165TA			D409	48T44813F01	MA165TA	
	D017	48T44813F01	MA165TA			● D410	48T44813F01	MA165TA	
	D018	48T44813F01	MA165TA			D411	48T44813F01	MA165TA	
	D019	48T44813F01	MA165TA			D413	48T44813F01	MA165TA	
●	D105	48T44813F01	MA165TA			D414	48T44813F01	MA165TA	
■	D105	48T44813F01	MA165TA			D501	48T44813F01	MA165TA	
☆	D105	48T44813F01	MA165TA			■ D502	48T44813F01	MA165TA	
★	D105	48T44813F01	MA165TA			★ D502	48T44813F01	MA165TA	
	D106	48T44813F01	MA165TA			◆ D502	48T44813F01	MA165TA	
	D107	48T44813F01	MA165TA			◇ D502	48T44813F01	MA165TA	
	D108	48T44813F01	MA165TA			☆ D502	48T44813F01	MA165TA	
	D109	48T44813F01	MA165TA			■ D503	48T44813F01	MA165TA	
	D110	48T44813F01	MA165TA			★ D503	48T44813F01	MA165TA	
●	D111	48T44813F01	MA165TA			☆ D503	48T44813F01	MA165TA	
	D112	48T44813F01	MA165TA			◆ D504	48T44813F01	MA165TA	
	D113	48T44813F01	MA165TA			◇ D504	48T44813F01	MA165TA	
	D115	48T44813F01	MA165TA			■ D505	48T44813F01	MA165TA	
	D117	48T44813F01	MA165TA			■ D506	48T44813F01	MA165TA	
●	D118	48T44813F01	MA165TA			★ D506	48T44813F01	MA165TA	
◆	D201	48T44813F01	MA165TA			☆ D508	48T44813F01	MA165TA	
◇	D201	48T44813F01	MA165TA			D507	48T44813F01	MA165TA	
◆	D202	48T44813F01	MA165TA			● D601	48T44813F01	MA165TA	
◇	D202	48T44813F01	MA165TA			● D701	48T44813F01	MA165TA	
	D204	48T44813F01	MA165TA			● D702	48T44813F01	MA165TA	
●	D227	48T44813F01	MA165TA			● D703	48T44813F01	MA165TA	
◆	D228	48T44813F01	MA165TA			● D704	48T44813F01	MA165TA	
◇	D228	48T44813F01	MA165TA			● D705	48T44813F02	MA165	
◆	D229	48T44813F02	MA165			● D706	48T44813F02	MA165	
◇	D229	48T44813F02	MA165			● D707	48T44813F02	MA165	
	D301	48T44813F01	MA165TA			D708	48T44813F01	MA165TA	
◆	D302	48T44813F01	MA165TA			● D709	48T44813F01	MA165TA	
◇	D302	48T44813F01	MA165TA			● D710	48T44813F01	MA165TA	
◆	D303	48T44813F01	MA165TA			● D711	48T44813F01	MA165TA	
◇	D303	48T44813F01	MA165TA			● D712	48T44813F01	MA165TA	
	D304	48T44813F01	MA165TA			● D713	48T44813F01	MA165TA	
	D305	48T44813F01	MA165TA			● D714	48T44813F02	MA165	
	D306	48T44813F01	MA165TA			● D715	48T44813F01	MA165TA	
■	D350	48T44813F02	MA165			ZD001	48T52739F38	Zener HZ6B-2	
★	D350	48T44813F02	MA165			ZD002	48T52739F38	Zener HZ6B-2	
	D401	48T44813F01	MA165TA			ZD003	48T52739F43	Zener HZ7A-1	

Note: ● : For Japanese model only (JA) ■ : For North American model only (UZ)
 ☆ : For General Foreign model only (EK) ◆ : For West Germany model only (T-117L SD)
 ☆ : For General Foreign model only (T-03 EK) ◇ : For West Germany model only (T-03L SD) Others : Common

Symbol No.	Part No.	Description		
	ZD004	48T52739F85	Zener HZ11B-2	
	ZD007	48T52739F97	Zener HZ30-1	
	ZD008	48T52739F95	Zener HZ27-2	
	ZD101	48T52739F11	Zener HZ3B-2	
	ZD201	48T52739F40	Zener HZ6C-1	
●	ZD401	48T52739F53	Zener HZ9A-2	
■	ZD701	48T52739F40	Zener HZ6C-1	
★	ZD701	48T52739F35	Zener HZ6A-2	
◆	ZD701	48T52739F35	Zener HZ8A-2	
☆	ZD701	48T52739F35	Zener HZ8A-2	
◇	ZD701	48T52739F35	Zener HZ8A-2	
◆	VD301	48T52826F01	Varactor SVC321SP-A2	
◇	VD301	48T52826F01	Varactor SVC321SP-A2	
	VD302	48T52826F01	Varactor SVC321SP-A2	
◆	VD303	48T52826F01	Varactor SVC321SP-A2	
◇	VD303	48T52826F01	Varactor SVC321SP-A2	
	VD304	48T52826F01	Varactor SVC321SP-A2	
Switches				
★	S401	40T72577F01	Slide SSSS22	
☆	S401	40T72577F01	Slide SSSS22	
	S501	40T84689F01	Slide SSSJ1(C)	
★	S502	40T72576F01	Slide SSSS21	
☆	S502	40T72576F01	Slide SSSS21	
■	S503	40T84689F01	Slide SSSJ1	
★	S504	40T72576F01	Slide SSSS21	
☆	S504	40T72576F01	Slide SSSS21	
Filters				
◆	BF101	91T74482F01	BPMB6A	
◇	BF101	91T74482F01	BPMB6A	
●	BF601	91T84593F01	SAP54MC70Z	
	CF101	91T84593F01	SFE10.7MXX	
	CF102	91T84593F01	SFE10.7MS3G	
	CF103	91T84599F01	SFE10.7MS3G	
	CF104	91T51131F02	SFE10.7 ML-A	
	CF301	91T80378F01	CER. BPU450C4N	
	L401	91T84809F01	ANT. BIRDY	
	L402	91T66943F01	NPX	
	L403	91T66943F01	NPX	

Symbol No.	Part No.	Description		
Crystal/Ceramic Locks				
	X201	48T84608F02	NDK 32.9075MHZ	
●	X501	48T84664F01	3.2M NDK	
	X502	48T84663F01	7.2M NDK	
	X503	48T84663F01	7.2M NDK	
●	X601	48T84595F01	NDK 64.95MHZ	
	X401	91T63469F03	Ceramic Lock 458F11	
●	X701	91T84612F01	Ceramic Lock CSB472F2	
Capacitors				
	C001	23S41198U66	ELY. 1000 μ F/35V	
	C002	23S40657F14	ELY. 100 μ F/16V	
	C003	23S40657F14	ELY. 100 μ F/16V	
	C004	23S40657F13	ELY. 47 μ F/16V	
	C005	23S40657F14	ELY. 100 μ F/16V	
	C007	23T74513F06	ELY. 18 μ F/5.5V	
	C008	23S40657F10	ELY. 10 μ F/16V	
	C009	23S40657F28	ELY. 47 μ F/35V	
	C010	23S40657F26	ELY. 47 μ F/35V	
	C011	23S40657F32	ELY. 10 μ F/50V	
	C012	23S40657F32	ELY. 10 μ F/50V	
	C013	23S40657F28	ELY. 47 μ F/35V	
	C014	23S40657F13	ELY. 47 μ F/16V	
	C015	23S40657F32	ELY. 10 μ F/50V	
	C016	23S40657F13	ELY. 47 μ F/16V	
	C017	08S40805F21	CER. 0.022 μ F	
	C018	08S40805F21	CER. 0.022 μ F	
	C105	08S40805F21	CER. 0.022 μ F	
	C106	08S40805F21	CER. 0.022 μ F	
	C107	08S40805F21	CER. 0.022 μ F	
	C108	21S40655F11	CER. 10pF	
	C109	08S40805F21	CER. 0.022 μ F	
	C110	08S40805F21	CER. 0.022 μ F	
	C111	08S40805F21	CER. 0.022 μ F	
	C112	08S40805F21	CER. 0.022 μ F	
	C113	08S40805F21	CER. 0.022 μ F	
	C114	23S40657F14	ELY. 100 μ F/16V	
	C115	08S40805F21	CER. 0.022 μ F	
	C116	08S40805F21	CER. 0.022 μ F	
	C117	08S40805F21	CER. 0.022 μ F	
	C118	08S40805F21	CER. 0.022 μ F	
	C119	08S40805F21	CER. 0.022 μ F	
	C120	08S40805F21	CER. 0.022 μ F	
	C121	08S40805F21	CER. 0.022 μ F	
	C122	08S40805F21	CER. 0.022 μ F	

Note: ● : For Japanese model only (JA) ■ : For North American model only (UZ)
 ★ : For General Foreign model only (EK) ◆ : For West Germany model only (T-117L SD)
 ☆ : For General Foreign model only (T-03 EX) ◇ : For West Germany model only (T-03L SD) Others : Common
 When replacing varactor diodes, VD301 ~ VD304, always diode with the same rank.

Symbol No.	Part No.	Description	Symbol No.	Part No.	Description
	C123	08S40805F21 CER. 0.022 μ F	◇	C224	08S40805F21 CER. 0.022 μ F
	C124	08S40805F21 CER. 0.022 μ F	◆	C225	23S40657F27 ELY. 0.47 μ F/50V
	C125	08S40805F21 CER. 0.022 μ F	◇	C226	23S40657F27 ELY. 0.47 μ F/50V
	C126	08S40805F21 CER. 0.022 μ F	◆	C226	21S40655F27 CER. 220pF
	C127	08S40805F21 CER. 0.022 μ F	◇	C226	21S40655F27 CER. 220pF
●	C128	23S40657F10 ELY. 10 μ F/16V		C227	21S40655F17 CER. 33pF
	C129	08S40805F21 CER. 0.022 μ F		C228	08S40805F21 CER. 0.022 μ F
	C130	08S40805F21 CER. 0.022 μ F		C229	23S40657F14 ELY. 100 μ F/16V
	C131	23S40857F14 ELY. 100 μ F/16V		C230	08S40805F21 CER. 0.022 μ F
	C132	08S40805F21 CER. 0.022 μ F		C231	08S40805F21 CER. 0.022 μ F
	C133	08S40805F21 CER. 0.022 μ F		C232	08S40805F21 CER. 0.022 μ F
	C134	23S40657F28 ELY. 1 μ F/50V		C233	08S40805F21 CER. 0.022 μ F
	C135	08S40805F21 CER. 0.022 μ F		C234	21S40655F12 CER. 12pF
	C136	08S40805F21 CER. 0.022 μ F		C235	21S40655F28 CER. 180pF
	C137	08S40805F21 CER. 0.022 μ F		C236	08S40805F21 CER. 0.022 μ F
	C138	08S40805F21 CER. 0.022 μ F		C237	23S40657F14 ELY. 100 μ F/16V
	C139	08S40805F21 CER. 0.022 μ F		C238	08S40805F21 CER. 0.022 μ F
	C140	23S40657F27 ELY. 0.47 μ F/50V		C239	08S40805F21 CER. 0.022 μ F
	C141	23S40657F14 ELY. 100 μ F/16V		C240	08S40805F21 CER. 0.022 μ F
	C142	23T42478F18 ELY. 0.1 μ F/50V		C241	08S40805F21 CER. 0.022 μ F
	C143	23S41198U27 ELY. 47 μ F/16V		C242	08S40805F21 CER. 0.022 μ F
	C201	08S40805F21 CER. 0.022 μ F		C243	08S40805F21 CER. 0.022 μ F
	C202	08S40805F21 CER. 0.022 μ F		C244	08S40805F08 CER. 1200pF
	C203	08S40805F07 CER. 1000pF		C245	23S40657F10 ELY. 10 μ F/16V
	C204	08S40805F21 CER. 0.022 μ F		C246	23S40657F10 ELY. 10 μ F/16V
	C205	08S40805F21 CER. 0.022 μ F		C247	08S40805F21 CER. 0.022 μ F
	C206	23S40657F10 ELY. 10 μ F/16V		C248	21S40655F17 CER. 33pF
	C207	08S40805F21 CER. 0.022 μ F		C249	08S40805F21 CER. 0.022 μ F
	C208	23S40657F10 ELY. 10 μ F/16V		C250	08S40805F21 CER. 0.022 μ F
	C209	08S40805F21 CER. 0.022 μ F		C251	21S40655F17 CER. 33pF
	C210	08S40805F07 CER. 1000pF		C252	21S40655F08 CER. 5pF
	C211	08S40805F21 CER. 0.022 μ F	◆	C253	08S40656F13 MYL. 0.01 μ F
	C212	23S40657F14 ELY. 100 μ F/16V	◇	C253	08S40656F13 MYL. 0.01 μ F
	C213	08S40805F21 CER. 0.022 μ F		C255	08S40805F21 CER. 0.022 μ F
	C214	08S40805F21 CER. 0.022 μ F		C256	08S40805F21 CER. 0.022 μ F
	C215	08S40805F21 CER. 0.022 μ F	◆	C257	08S40656F13 MYL. 0.01 μ F
	C216	08S40805F21 CER. 0.022 μ F	◇	C257	08S40656F13 MYL. 0.01 μ F
	C218	23S40657F30 ELY. 3.3 μ F/50V	◆	C258	08S40656F13 MYL. 0.01 μ F
	C219	23T43247F09 ELY. 10 μ F/16V	◇	C258	08S40656F13 MYL. 0.01 μ F
	C220	23S40657F31 ELY. 4.7 μ F/50V	◆	C301	08S40805F21 CER. 0.022 μ F
◆	C222	23S40657F13 ELY. 47 μ F/16V	◇	C301	08S40805F21 CER. 0.022 μ F
◇	C222	23S40657F13 ELY. 47 μ F/16V		C302	08S40805F21 CER. 0.022 μ F
◆	C223	21S40655F27 CER. 220pF	◆	C303	21S40655F19 CER. 47pF
◇	C223	21S40655F27 CER. 220pF	◇	C303	21S40655F19 CER. 47pF
◆	C224	08S40805F21 CER. 0.022 μ F		C304	08S40805F21 CER. 0.022 μ F

Note: ● : For Japanese model only (JA) ■ : For North American model only (UZ)
 ★ : For General Foreign model only (EK) ◆ : For West Germany model only (T-117L SD)
 ☆ : For General Foreign model only (T-03 EK) ◇ : For West Germany model only (T-03L SD) Others : Common

Symbol No.	Part No.	Description	Symbol No.	Part No.	Description
	C305	08S40805F21 CER. 0.022 μ F	●	C417	23S40657F10 ELY. 10 μ F/16V
	C306	08S40805F21 CER. 0.022 μ F	●	C418	23S40657F10 ELY. 10 μ F/16V
	C307	08S40805F21 CER. 0.022 μ F		C419	23T43247P04 ELY. 0.47 μ F/50V
	C308	08S40805F21 CER. 0.022 μ F		C420	23S40657F27 ELY. 0.47 μ F/50V
	C309	23S40657F10 ELY. 10 μ F/16V		C421	08S40856F13 MYL. 0.01 μ F
	C310	08S40805F21 CER. 0.022 μ F		C422	23S40657F10 ELY. 10 μ F/16V
	C311	08S40805F07 CER. 1000pF		C423	23S40657F10 ELY. 10 μ F/16V
	C312	08S40805F21 CER. 0.022 μ F		C424	23S40657F29 ELY. 2.2 μ F/50V
	C313	08S40805F21 CER. 0.022 μ F		C425	23S40657F29 ELY. 2.2 μ F/50V
	C314	23S40657F30 ELY. 3.3 μ F/50V		C426	23S40657F14 ELY. 100 μ F/16V
	C315	08S40805F21 CER. 0.022 μ F	◆	C427	21S40655F24 CER. 120pF
	C316	23S40657F30 ELY. 3.3 μ F/50V	◇	C427	21S40655F24 CER. 120pF
	C317	23S40657F27 ELY. 0.47 μ F/50V	●	C428	08T52448F06 PP. 510pF
	C318	08S40805F21 CER. 0.022 μ F	■	C428	08T52448F10 PP. 750pF
	C320	08S40805F21 CER. 0.022 μ F	★	C428	08T52448F06 PP. 510pF
	C321	08S40805F07 CER. 1000pF	◆	C428	08T52448F06 PP. 510pF
	C322	23S40657F14 ELY. 100 μ F/16V	☆	C428	08T52448F06 PP. 510pF
	C323	08S40805F21 CER. 0.022 μ F	◇	C428	08T52448F06 PP. 510pF
	C327	08S40805F21 CER. 0.022 μ F	●	C429	08T52448F06 PP. 510pF
	C328	23S40657F10 ELY. 10 μ F/16V	■	C429	08T52448F10 PP. 750pF
◆	C329	21S40655F24 CER. 120pF	★	C429	08T52448F06 PP. 510pF
◇	C329	21S40655F24 CER. 120pF	◆	C429	08T52448F06 PP. 510pF
	C330	21S40655F11 CER. 10pF	☆	C429	08T52448F06 PP. 510pF
◆	C331	21S40655F27 CER. 220pF	◇	C429	08T52448F06 PP. 510pF
◇	C331	21S40655F27 CER. 220pF		C430	08S40856F13 MYL. 0.01 μ F
	C332	21S40655F29 CER. 330pF		C431	23S40657F10 ELY. 10 μ F/16V
	C333	08S40805F21 CER. 0.022 μ F		C432	23S40657F10 ELY. 10 μ F/16V
	C401	23S40657F10 ELY. 10 μ F/16V		C433	23S40657F10 ELY. 10 μ F/16V
	C402	23S40657F10 ELY. 10 μ F/16V		C434	23S40657F10 ELY. 10 μ F/16V
	C403	23S40657F14 ELY. 100 μ F/16V		C435	23S40657F10 ELY. 10 μ F/16V
	C404	23S40657F10 ELY. 10 μ F/16V		C437	21S40655F23 CER. 100pF
	C405	23S40657F10 ELY. 10 μ F/16V		C438	08T52448F07 PP. 580pF
	C406	08S40805F07 CER. 1000pF		C439	23S40657F10 ELY. 10 μ F/16V
	C407	08S40856F21 MYL. 0.047 μ F		C440	23S40657F02 ELY. 47 μ F/6.3V
	C408	23S40657F27 ELY. 0.47 μ F/50V		C441	23S40657F10 ELY. 10 μ F/16V
	C409	23S40657F28 ELY. 1 μ F/50V		C442	23S40657F11 ELY. 22 μ F/16V
	C410	23S40657F28 ELY. 1 μ F/50V		C501	23S40657F26 ELY. 47 μ F/35V
	C411	23S40657F28 ELY. 1 μ F/50V		C502	23S40657F28 ELY. 1 μ F/50V
	C412	08S40856F13 MYL. 0.01 μ F		C503	23S40657F27 ELY. 0.47 μ F/50V
	C413	23S40657F14 ELY. 100 μ F/16V	●	C504	23S40657F27 ELY. 0.47 μ F/50V
	C414	23S40657F14 ELY. 100 μ F/16V	●	C505	23S40657F28 ELY. 1 μ F/50V
★	C415	08T52448F10 PP. 750pF	●	C506	23S40657F03 ELY. 100 μ F/6.3V
☆	C415	08T52448F10 PP. 750pF	●	C509	08S40805F07 CER. 1000pF
★	C416	08T52448F10 PP. 750pF	●	C510	08S40805F07 CER. 1000pF
☆	C416	08T52448F10 PP. 750pF	●	C511	08S40805F21 CER. 0.022 μ F

Note: ● : For Japanese model only (JA) ■ : For North American model only (UZ)
 ★ : For General Foreign model only (EK) ◆ : For West Germany model only (T-117L SD)
 ☆ : For General Foreign model only (T-03 EK) ◇ : For West Germany model only (T-03L SD) Others : Common

Symbol No.	Part No.	Description	Symbol No.	Part No.	Description
● C512	21S40655F17	CER. 33pF	● C704	23S40657F27	ELY. 0.47 μ F/50V
● C513	21S40655F17	CER. 33pF	● C705	23S40657F31	ELY. 4.7 μ F/50V
C514	08S40805F21	CER. 0.022 μ F	● C706	23S40657F31	ELY. 4.7 μ F/50V
C515	21S40655F17	CER. 33pF	● C709	23S40657F12	ELY. 33 μ F/16V
C516	21S40655F17	CER. 33pF	● C710	08T42081U12	POLY. 300pF
C517	08S40805F21	CER. 0.022 μ F	● C711	23S40657F31	ELY. 4.7 μ F/50V
C518	21S40655F22	CER. 82pF	● C712	23S40657F10	ELY. 10 μ F/16V
C519	21S40655F22	CER. 82pF	● C713	23S40657F10	ELY. 10 μ F/16V
C520	08S40805F21	CER. 0.022 μ F	● C714	23T42477F09	ELY. B.P 4.7 μ F/25V
C522	21S40655F19	CER. 47P	● C715	23T43247F08	ELY. 4.7 μ F/25V
C523	21S40655F17	CER. 33pF	● C716	23T43247F05	ELY. 1 μ F/50V
● C524	23S40657F31	ELY. 4.7 μ F/50V	● C717	23T43247F05	ELY. 1 μ F/50V
● C525	23T41386F39	ELY. B.P 0.47 μ F/50V	◆ VC301	20T47503F02	Trimmer TZ03 (RED)
◆ C525	23T41386F39	ELY. B.P 0.47 μ F/50V	◇ VC301	20T47503F02	Trimmer TZ03 (RED)
◇ C525	23T41386F39	ELY. B.P 0.47 μ F/50V	VC302	20T47503F02	Trimmer TZ03 (RED)
● C603	08S40805F21	CER. 0.022 μ F	◆ VC303	20T47503F02	Trimmer TZ03 (RED)
● C604	23S40657F10	ELY. 10 μ F/16V	◇ VC303	20T47503F02	Trimmer TZ03 (RED)
● C605	08S40805F21	CER. 0.022 μ F	VC304	20T47503F02	Trimmer TZ03 (RED)
● C607	08S40805F21	CER. 0.022 μ F	VC401	20T47503F03	Trimmer TZ03 (YEL.)
● C609	08S40805F21	CER. 0.022 μ F	VC402	20T47503F03	Trimmer TZ03 (YEL.)
● C610	21S40655F26	CER. 180pF	Coils		
● C611	08S40805F21	CER. 0.022 μ F	L101	24T84602F01	1FT. 10.7MHA (BLK)
● C612	21S40655F06	CER. 5pF	L103	24T50508F14	IND. 2.2 μ H
● C613	21S40655F26	CER. 180pF	L104	24T84602F01	1FT. 10.7MHA (BLK)
● C614	21S40655F13	CER. 15pF	L105	24T84605F01	D1SCR.
● C615	21S40655F03	CER. 2pF	L106	24T50508F14	IND. 2.2 μ H
● C616	08S40805F21	CER. 0.022 μ F	L107	24T50508F14	IND. 2.2 μ H
◆ C616	08S40805F21	CER. 0.022 μ F	L108	24T50508F30	IND. 47 μ H
◇ C616	08S40805F21	CER. 0.022 μ F	L109	24T50508F30	IND. 47 μ H
● C617	08S40805F21	CER. 0.022 μ F	L201	24T50508F14	IND. 2.2 μ H
◆ C617	08S40805F21	CER. 0.022 μ F	L202	24T84607F01	VCO 10.7MHZ
◇ C617	08S40805F21	CER. 0.022 μ F	◆ L203	24T50508F14	IND. 2.2 μ H
● C618	08S40805F21	CER. 0.022 μ F	◇ L203	24T50508F14	IND. 2.2 μ H
● C619	08S40805F21	CER. 0.022 μ F	L204	24T50508F14	IND. 2.2 μ H
● C620	08S40805F21	CER. 0.022 μ F	L205	24T74509F01	10.7DOUBLER (BLK)
● C621	08S40805F21	CER. 0.022 μ F	L206	24T74510F01	32.1TRIPLER
● C622	21S40655F03	CER. 2pF	L207	24T50508F11	IND. 1.2 μ H
● C623	21S40655F11	CER. 10pF	L208	24T74511F01	0.8MIXER
● C624	08S40805F21	CER. 0.022 μ F	L209	24T80074F01	0.8MIXER 2ND
● C625	08S40805F21	CER. 0.022 μ F	L210	24T50508F14	IND. 2.2 μ H
● C626	08S40805F21	CER. 0.022 μ F	L211	24T50508F14	IND. 2.2 μ H
● C627	23S40657F14	ELY. 100 μ F/16V			
● C701	23S40657F14	ELY. 100 μ F/16V			
● C702	23S40657F31	ELY. 4.7 μ F/50V			
● C703	23S40657F28	ELY. 1 μ F/50V			

Note: ● : For Japanese model only (JA) ■ : For North American model only (UZ)
 ★ : For General Foreign model only (EK) ◆ : For West Germany model only (T-117L SD)
 ☆ : For General Foreign model only (T-03 EK) ◇ : For West Germany model only (T-03L SD) Others : Common

Symbol No.	Part No.	Description			Symbol No.	Part No.	Description		
◆	L212	24T50508F38	IND. 220 μ H		Jack				
◇	L212	24T50508F38	IND. 220 μ H		●	E401	09T84616F01	Plate phone T5855	
◆	L213	24T50508F38	IND. 220 μ H		■	E401	09T84616F01	Plate phone T5855	
◇	L213	24T50508F38	IND. 220 μ H		★	E401	09T84616F01	Plate phone T5855	
	L214	24T50508F14	IND. 2.2 μ H		◆	E401	09T84616F01	Plate phone T5855	
	L215	24T50508F38	IND. 220 μ H		☆	E401	09T84616F02	Plate phone T5855	
	L216	24T50508F38	IND. 220 μ H		◇	E401	09T84616F02	Plate phone T5855	
◆	L217	24T50508F38	IND. 220 μ H		E501	09T84124F01	Head phone MINI W		
◇	L217	24T50508F38	IND. 220 μ H		Station Switch P.C. Board				
◆	L301	24T90785F01	Trans. LW ANT		Transistors				
◇	L301	24T90785F01	Trans. LW ANT		Q801	48T81102F01	2SA1015		
	L302	24T90784F01	Trans. MW ANT		or	48T81104F01	2SA993A		
	L303	24T67274F01	SFL450B-3 (WHT)		Q802	48S43525F02	2SC1815		
	L304	24T53327F01	AM IP (BLK)		Diodes				
◆	L305	24T57627F01	Trans. LW OSC (BLK)		D801	48T44813F01	MA165TA		
◇	L305	24T57627F01	Trans. LW OSC (BLK)		D802	48T44813F01	MA165TA		
	L306	24T53328F01	Trans. AM OSC		D803	48T44813F01	MA165TA		
	L307	24T50508F14	IND. 2.2 μ H		D804	48T44813F01	MA165TA		
●	L601	24T84590F01	BALUN. 75-75		D805	48T44813F01	MA165TA		
●	L602	24T50508F14	IND. 2.2 μ H		D806	48T44813F01	MA165TA		
●	L603	24T50508F11	IND. 1.2 μ H		D807	48T44813F01	MA165TA		
●	L604	24T84596F01	1FT. 10.7MHZ (BLK)		Switches				
●	L605	24T50508F14	IND. 2.2 μ H		S801	40T84654F01	SKHHQW (DOWN)		
●	L606	24T50508F08	IND. 0.88 μ H		S802	40T84654F01	SKHHQW (UP)		
●	L607	24T50508F14	IND. 2.2 μ H		S803	40T84654F01	SKHHQW (FM)		
Resistors/Thermistors					S804	40T84654F01	SKHHQW (AM)		
●	R5001	51T51133F02	Block 100K ohm x4		●	S805	40T84654F01	SKHHQW (TV)	
	R5002	51T51133F03	Block 10K ohm x7		◆	S805	40T84654F01	SKHHQW (LW)	
	VR101	18T42748F07	SOL V 1K ohm		◇	S805	40T84654F01	SKHHQW (LW)	
	VR102	18T42748F17	SOL V 47K ohm		●	S806	40T84654F01	SKHHQW (MAIN)	
	VR103	18T42748F17	SOL V 47K ohm		●	S807	40T84654F01	SKHHQW (SUB)	
●	VR104	18T42748F17	SOL V 47K ohm		●	S808	40T84654F01	SKHHQW (MAIN-SUB)	
	VR201	18T42748F13	SOL V 10K ohm		S809	40T84654F01	SKHHQW (M7/M9)		
	VR202	18T42748F13	SOL V 10K ohm		S810	40T84654F01	SKHHQW (M8/M20)		
	VR203	18T42748F17	SOL V 47K ohm		S811	40T84654F01	SKHHQW (M9/M21)		
	VR204	18T42748F07	SOL V 1K ohm		S812	40T84654F01	SKHHQW (M10/M22)		
	VR301	18T42748F13	SOL V 10K ohm		S813	40T84654F01	SKHHQW (M11/M23)		
	VR302	18T42748F13	SOL V 10K ohm		S814	40T84654F01	SKHHQW (M12/M24)		
	VR401	18T42748F24	SOL V 680K ohm		S815	40T84654F01	SKHHQW (M1~M12/M13~M24)		
	VR402	18T42748F24	SOL V 680K ohm		S816	40T84654F01	SKHHQW (M1/M13)		
	VR403	18T42748F17	SOL V 47K ohm		S817	40T84654F01	SKHHQW (M2/M14)		
	VR404	18T42748F19	SOL VR 100K ohm		S818	40T84654F01	SKHHQW (M3/M15)		
	VR501	18C42061J18	VARIABLE 100K ohm						
●	VR701	18T42748F11	VOL. 4.7K-B						
●	VR702	18T42748F15	SOL V 22K ohm						
	TH201	48T57369F13	Thermistor 2.5K ohm						
	TH301	48T57369F13	Thermistor 2.5K ohm						

Note: ● : For Japanese model only (JA) ■ : For North American model only (UZ)
 ★ : For General Foreign model only (EK) ◆ : For West Germany model only (T-117L SD)
 ☆ : For General Foreign model only (T-03 EK) ◇ : For West Germany model only (T-03L SD) Others : Common

Symbol No.	Part No.	Description		
S819	40T84654F01	SKHHQW (M4/M16)		
S820	40T84654F01	SKHHQW (M5/M17)		
S821	40T84654F01	SKHHQW (M6/M18)		
S822	40T84654F01	SKHHQW (MEMORY)		
FL/Display P.C. Board				
IC's				
IC901	51T84655F01	TC9190N		
IC902	51T84655F01	TC9190N		
Diodes				
D901	48T44813F01	MA165TA		
D902	48T44813F01	MA165TA		
Switches				
S901	40T84654F01	SKHHQW (REC. CAL)		
S902	40T84654F01	SKHHQW (PROG)		
S903	40T84654F01	SKHHQW (1F BAND)		
S904	40T84654F01	SKHHQW (AUTO SEEK)		
Capacitors				
● C901	08T65480F53	CER. 2200P		
■ C901	08T65480F52	CER. 1800P		
◆ C901	08T65480F53	CER. 2200P		
★ C901	08T65480F53	CER. 2200P		
☆ C901	08T65480F53	CER. 2200P		
◇ C901	08T65480F52	CER. 1800P		
C902	08T65480F82	CER. 0.022 μ F		
● C903	08T65480F53	CER. 2200pF		
◆ C903	08S85480F55	CER. 3300P		
■ C903	08T65480F53	CER. 2200P		
★ C903	08T65480F53	CER. 2200P		
☆ C903	08T65480F53	CER. 2200P		
◇ C903	08S85480F55	CER. 3300P		
C904	08T65480F82	CER. 0.022 μ F		
● C910	21C45322G25	CER. 220P		
FL Switch P.C. Board				
Transistors				
Q1001	48T81102F01	2SA1015		
Q1002	48T57337F03	2SD1330		

Symbol No.	Part No.	Description		
Miscellaneous				
● E101	09T84167F01	Terminal, Antenna		
■ E101	09T84167F02	Terminal, Antenna Mult		
★ E101	09T84167F02	Terminal, Antenna Mult		
◆ E101	09T84167F02	Terminal, Antenna Mult		
☆ E101	09T84167F02	Terminal, Antenna Mult		
◇ E101	09T84167F02	Terminal, Antenna Mult		
● F001	65T55050F08	Fuse, MF60NE 1A-125V		
■ F001	65T52486F08	Fuse, MF61NM 1A-125V		
★ F001	65T42077U13	Fuse, Senko T-500mA		
◆ F001	65T42077U13	Fuse, Senko T-500mA		
☆ F001	65T42077U13	Fuse, Senko T-500mA		
◇ F001	65T42077U13	Fuse, Senko T-500mA		
■ F002	65T52486F01	Fuse, MF61NM 0.5A-125V		
★ F002	65T42077U10	Fuse, Senko T-250mA		
◆ F002	65T42077U10	Fuse, Senko T-250mA		
☆ F002	65T42077U10	Fuse, Senko T-250mA		
◇ F002	65T42077U10	Fuse, Senko T-250mA		
FL901	65T84168F01	Meter, FL 10-BT-15GK		
LD801	48T66616F02	LED, SLR-54VR3 (RED)		
LD802	48T66616F02	LED, SLR-54VR3 (RED)		
LD803	48T66616F02	LED, SLR-54VR3 (RED)		
LD804	48T66616F02	LED, SLR-54VR3 (RED)		
LD805	48T66616F02	LED, SLR-54VR3 (RED)		
● P001	28T86771F01	AC Power Cord		
■ P001	28T40916U01	AC Power Cord		
★ P001	28T43812P03	AC Power Cord		
◆ P001	28T43812P04	AC Power Cord		
☆ P001	28T43812P03	AC Power Cord		
◇ P001	28T43812P04	AC Power Cord		
S001	40T84872P01	Switch, Push SPUL12 (Power)		
★ S002	40T80258F03	Switch, Volt Select 2C		
◆ S002	40T80258F03	Switch, Volt Select 2C		
☆ S002	40T80258F01	Switch, Volt Select 4C		
◇ S002	40T80258F03	Switch, Volt Select 2C		
● T101	25T84662F01	Power Trans		
■ T101	25T84662F04	Power Trans		
★ T101	25T84662F03	Power Trans		
◆ T101	25T84662F02	Power Trans		
☆ T101	25T84662F03	Power Trans		
◇ T101	25T84662F02	Power Trans		

Note: ● : For Japanese model only (JA) ■ : For North American model only (UZ)
 ★ : For General Foreign model only (EK) ◆ : For West Germany model only (T-117L SD)
 ☆ : For General Foreign model only (T-03 EK) ◇ : For West Germany model only (T-03L SD) Others : Common

Cabinet Assembly Parts List

Note: The parts without part numbers are not supplied.

Symbol No.	IN-dex	Part No.	Description	Symbol No.	IN-dex	Part No.	Description
●	1	15D81388F01	Cover, Top	●	27	09T58943F09	Holder, Wire 2P
■	1	15D81388F01	Cover, Top	■	28	07A83876F01	Support, FL
★	1	15D81388F01	Cover, Top	●	31	64D83791F01	Panel, Front
◆	1	15D81388F01	Cover, Top	■	31	64D83791F02	Panel, Front
☆	1	15D81388F02	Cover, Top	★	31	64D83791F02	Panel, Front
◇	1	15D81388F02	Cover, Top	◆	31	64D83791F03	Panel, Front
	2	75S72374F66	Cushion, Rubber	☆	31	64D83791F05	Panel, Front
	3	03S40038U01	Screw, W/washer (M4x8)	◇	31	64D83791F04	Panel, Front
	4	03A82468F01	Screw, Blind (M3x10)	●	32	77T84591F01	TV, Tuner TEM2. (FE601)
	7	03C42723U01	Screw, Cup (M3x6)	●	33	77T84597F01	FM, Tuner TFFG3J115 (FE101)
●	8	01A80230F01	Assembly, Trannleg	■	33	77T84597F03	FM, Tuner TFFG3U114A (FE101)
■	8	01A80230F01	Assembly, Trannleg	★	33	77T84597F03	FM, Tuner TFFG3U114A (FE101)
◆	8	01A80230F01	Assembly, Trannleg	◇	33	77T84597F02	FM, Tuner TFFG3E127A (FE101)
★	8	75T57059F01	PAD Trannleg	☆	33	77T84597F03	FM, Tuner TFFG3U114A (FE101)
◇	8	75T57059F01	PAD Trannleg	◇	33	77T84597F02	FM, Tuner TFFG3E127A (FE101)
☆	8	75T57059F01	PAD Trannleg	☆	33	77T84597F03	FM, Tuner TFFG3U114A (FE101)
●	9	75A67064F01	Felt	◇	33	77T84597F02	FM, Tuner TFFG3E127A (FE101)
■	9	75A67064F01	Felt	●	34	09T51960F01	Holder, Fuse
◆	9	75A67064F01	Felt	■	34	09T51960F01	Holder, Fuse
	10	03S44206G20	Screw, Pan (M4x12)	★	34	09T51410F01	Holder, Fuse (Semko)
●	11	15C83802F01	Cover, Rear	◆	34	09T51410F01	Holder, Fuse (Semko)
■	11	15C83802F05	Cover, Rear	☆	34	09T51410F01	Holder, Fuse (Semko)
★	11	15C83802F02	Cover, Rear	◇	34	09T51410F01	Holder, Fuse (Semko)
◆	11	15C83802F03	Cover, Rear	●	35	55T84876F01	Lock, Antenna Holder
☆	11	15C83802F07	Cover, Rear	●	36	01T84592F02	Assembly, Coax Cable RCA
◇	11	15C83802F06	Cover, Rear	●	37	01T84592F01	Assembly, Coax Cable
	12	03S71031F04	Screw, Blind (M3x8)	●	38	01T84592F03	Assembly, Coax Cable 8.1M
	15	03C42723U02	Screw, Cup (M3x8)		40	43T93516F01	Spacer P.C. Board
	16	03S71031F02	Screw, Blind (M2.6x8)	★	41	03D40014G49	Screw, W/washer (M3x8)
	17	04A53398F01	Washer, Nylon (M2.6)	◆	41	03D40014G49	Screw, W/washer (M3x8)
●	18	01C84628F01	Assembly, Frame Front	☆	41	03D40014G49	Screw, W/washer (M3x8)
■	18	01C90598F01	Assembly, Frame Front	◇	41	03D40014G49	Screw, W/washer (M3x8)
★	18	01C90598F01	Assembly, Frame Front	★	42	47C64899F44	Shaft
◆	18	01C90791F01	Assembly, Frame Front	◆	42	47C64899F44	Shaft
☆	18	01C92304F01	Assembly, Frame Front	☆	42	47C64899F44	Shaft
◇	18	01C92203F01	Assembly, Frame Front	◇	42	47C64899F44	Shaft
●	21	36B70885F07	Knob, Power	●	44	14S66709F01	Insulator, Transistor
■	21	36B70885F07	Knob, Power				
★	21	36B70885F07	Knob, Power				
◆	21	36B70885F07	Knob, Power				
☆	21	36B70885F08	Knob, Power				
◇	21	36B70885F08	Knob, Power				
	22	03S44206G40	Screw, Blind (M3x4)				
	23	43B41625J02	Support Cord				
	24	29A41814G01	Lug				

Note: ● : For Japanese model only (JA) ■ : For North American model only (UZ)
 ★ : For General Foreign model only (EK) ◆ : For West Germany model only (T-117L SD)
 ☆ : For General Foreign model only (T-03 EK) ◇ : For West Germany model only (T-03L SD) Others : Common

Exploded View (Cabinet)

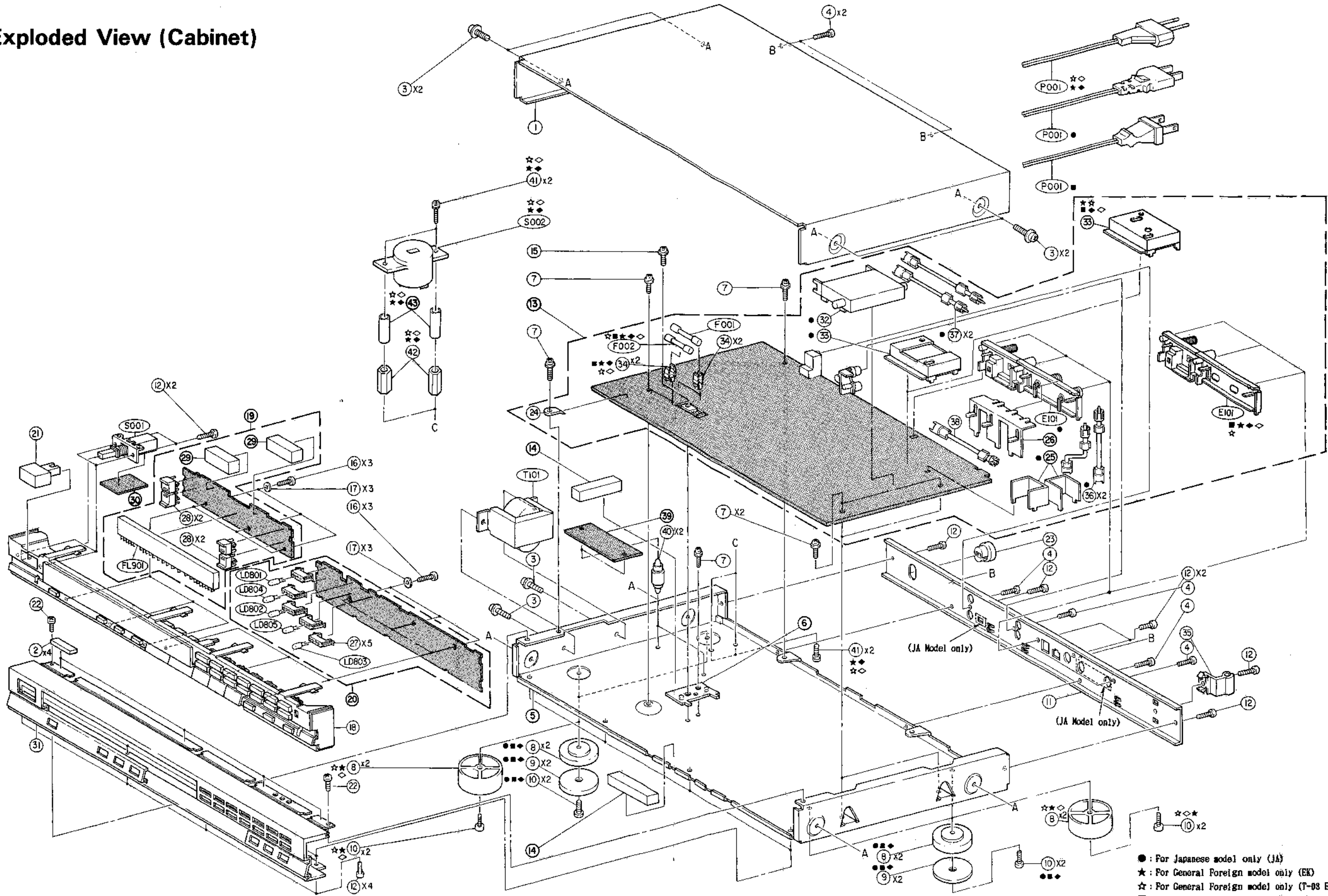

- : For Japanese model only (JA)
- ★ : For General Foreign model only (EK)
- ☆ : For General Foreign model only (T-03 EK)
- : For North American model only (UZ)
- ◆ : For West Germany model only (T-117L SD)
- ◇ : For West Germany model only (T-03L SD)
- Others : Common

Packing Method View

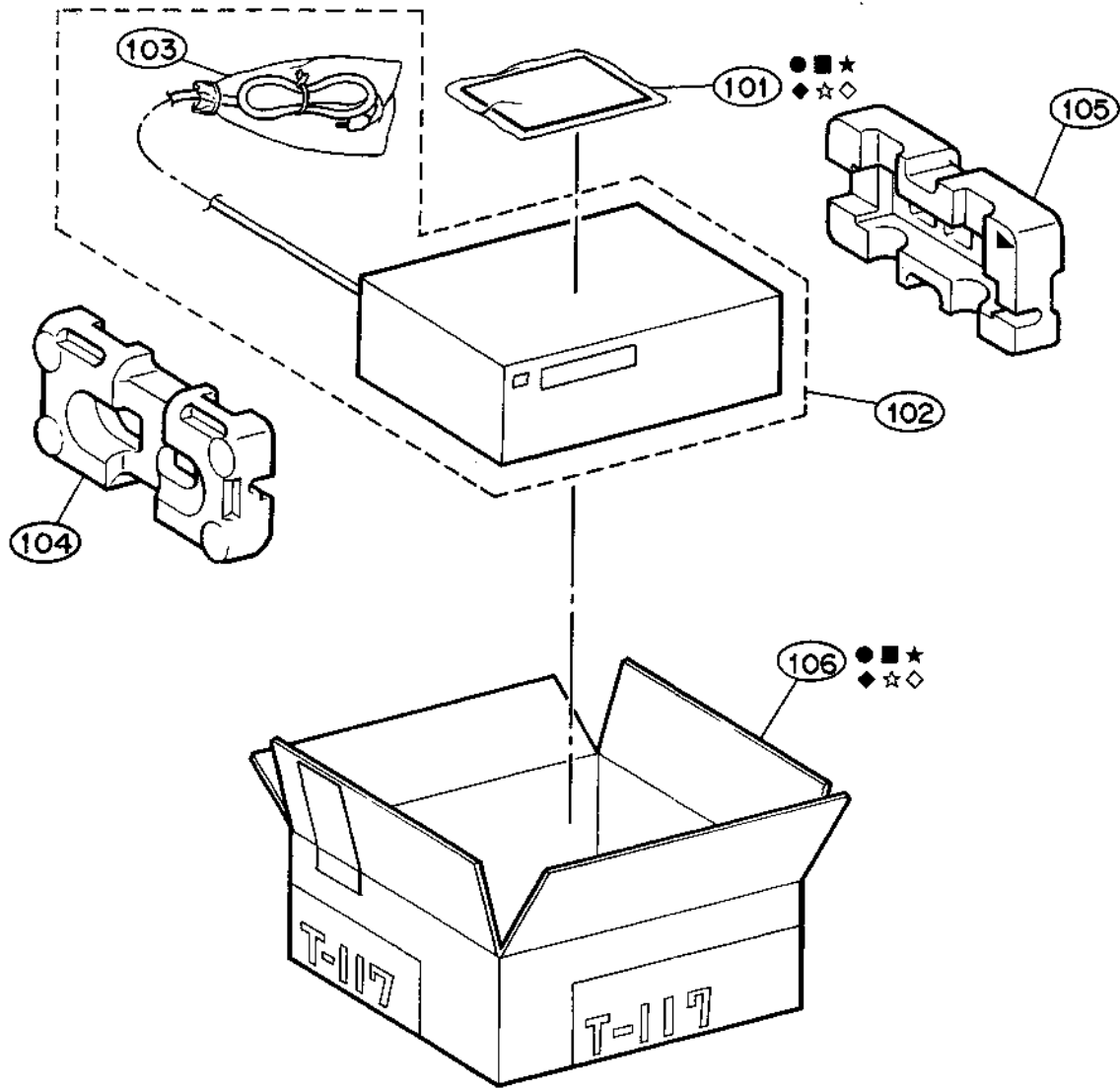

Packing Assembly Parts List

Symbol No.	Part No.	Description	Symbol No.	Part No.	Description
●	101-1	68P83132F28	Owner's Manual		
■	101-1	68P83132F29	Owner's Manual		
★	101-1	68P83132F30	Owner's Manual		
◆	101-1	68P83132F30	Owner's Manual		
☆	101-1	68P83710F10	Owner's Manual		
◇	101-1	68P83710F10	Owner's Manual		
●	101-2	85T90254F01	Antenna, FM		
■	101-2	85T90254F02	Antenna, FM		
★	101-2	85T90254F02	Antenna, FM		
◆	101-2	85T90254F02	Antenna, FM		
☆	101-2	85T90254F02	Antenna, FM		
◇	101-2	85T90254F02	Antenna, FM		
	101-3	85T84674F01	Antenna, AM		
	101-4	28T84675F01	Plug, F-Type (FM)		
●	101-5	09T71169F01	Plug, TV, Antenna		
■	101-5	09T71169F01	Plug, TV, Antenna		
★	101-5	09T71169F01	Plug, TV, Antenna		
◆	101-5	09T71169F01	Plug, TV, Antenna		
	101-6	28T70621F03	Plug, Output		
	101-7	01T82091F01	Assy, Mini Plug Cord		
☆	101-8	28T67847F01	Plug Audio Cable		
◇	101-8	28T67847F01	Plug Audio Cable		
	102	56B40442T07	Packing, Front Frame		
	103	56B40238G08	Sack, Polyethylene		
	104	56D81391F01	Packing, Tray		
	105	56D81391F02	Packing, Tray		
●	108	56S71001F38	Carton, Packing		
■	108	56S83833F15	Carton, Packing		
★	108	56S83833F15	Carton, Packing		
◆	108	56S83833F18	Carton, Packing		
☆	108	56S83833F20	Carton, Packing		
◇	108	56S83833F19	Carton, Packing		

Note: ● : For Japanese model only (JA) ■ : For North American model only (UZ)
 ★ : For General Foreign model only (EK) ◆ : For West Germany model only (T-117L SD)
 ☆ : For General Foreign model only (T-03 EK) ◇ : For West Germany model only (T-03L SD) Others : Common

Semi-Conductor Lead Identifications

L78N12: IC001

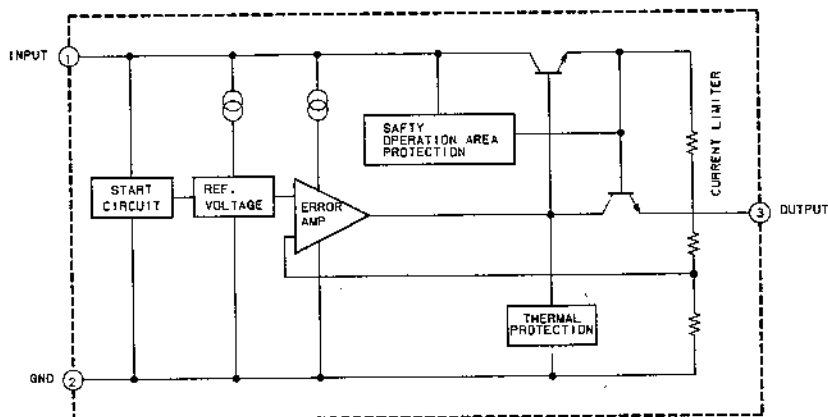
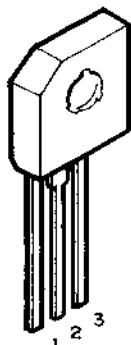

μ PC1163H: IC101, 102

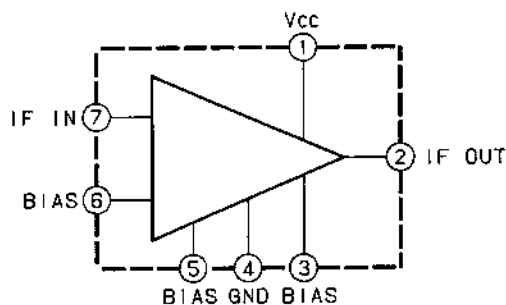
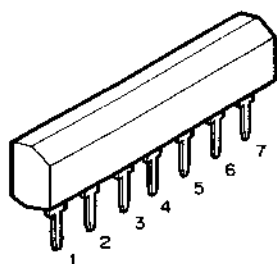

LA1231N: IC103

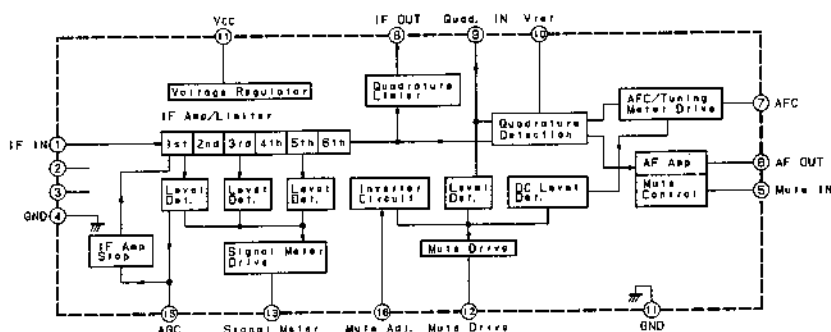
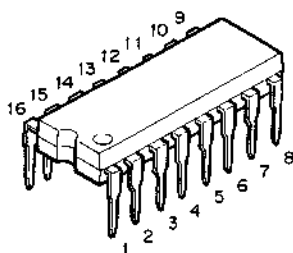

BA401: IC104

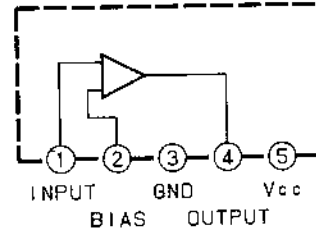
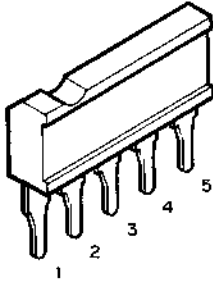

μ PC1211V: IC201

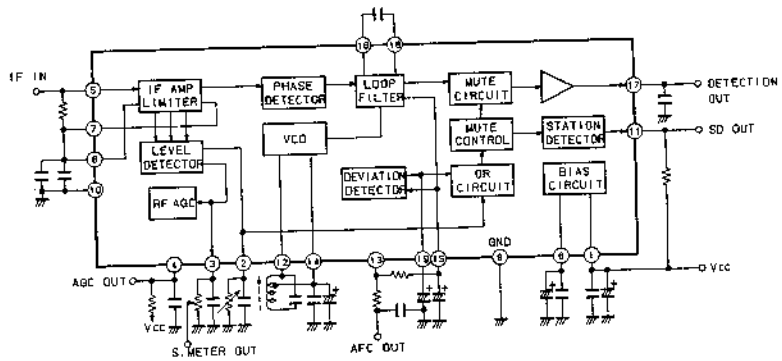
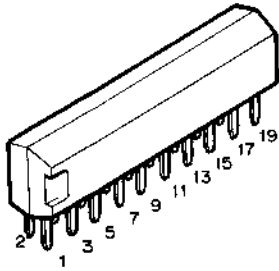

BU4053B: IC202.506

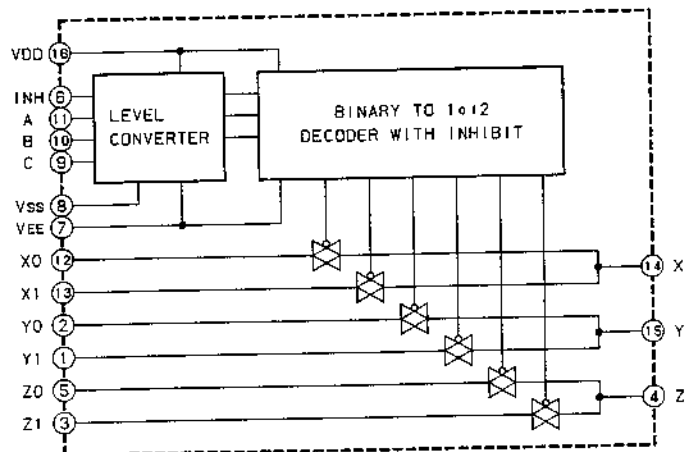
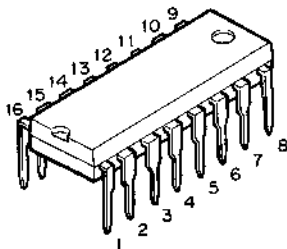

BA402:1C203

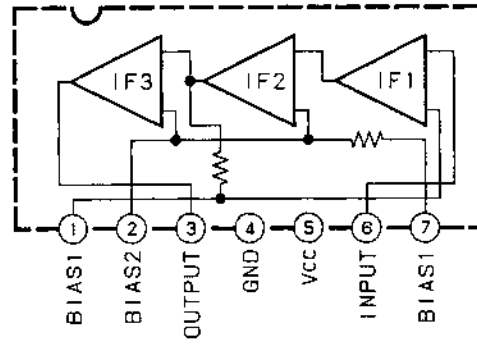
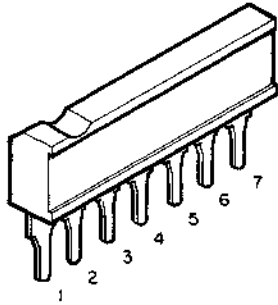

M74LS123P:1C204

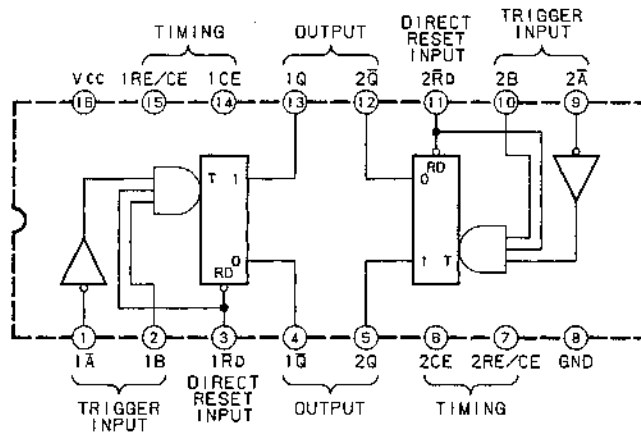
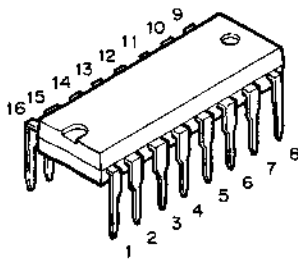

LA1245:1C301

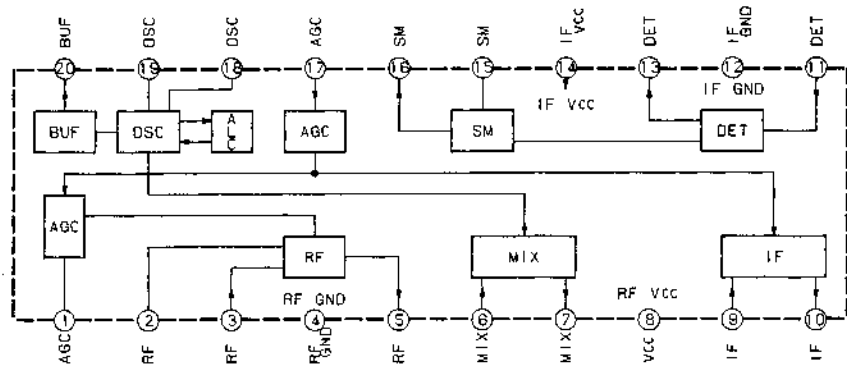
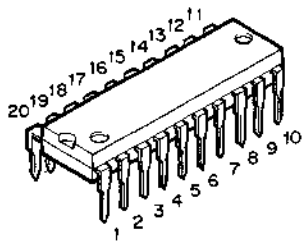

M5238P: IC401.404

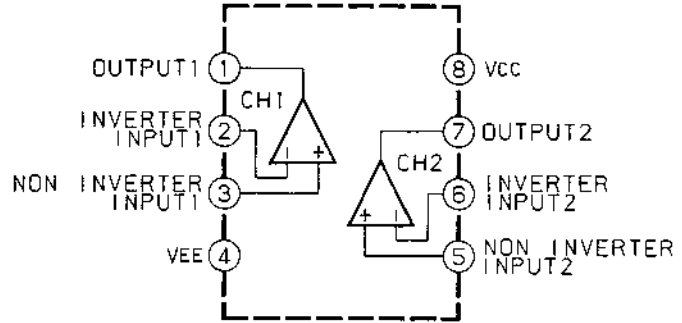
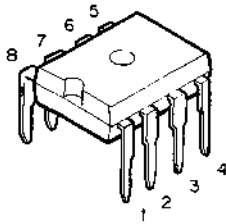

LA3450: IC402

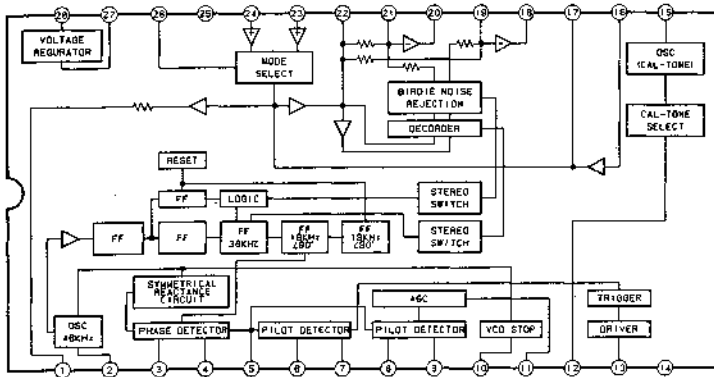
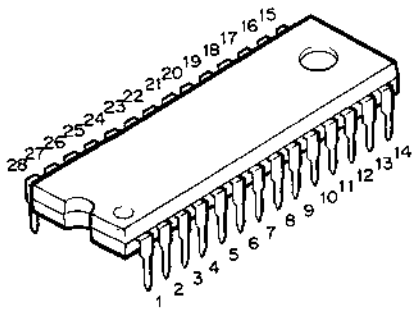

Pin No	DESCRIPTION
1	COMPOSITE AMP OUT
2	OSC
3	LOOP FILTER
4	LOOP FILTER
5	PLL IN
6	PILOT SYNC DETECT FILTER
7	PILOT SYNC DETECT FILTER
8	PILOT SYNC DETECT FILTER
9	PILOT SYNC DETECT FILTER
10	VCO STOP
11	PILOT CANCEL
12	CAL-TONE CONTROL
13	STEREO INDICATOR
14	GND
15	CAL-TONE OSC OUT
16	CAL-TONE IN
17	PILOT CANCEL IN
18	POST AMP OUT
19	POST AMP IN
20	POST AMP OUT
21	POST AMP IN
22	SEPARATION ADJ
23	AM IN
24	FM IN
25	SIGNAL GND
26	AM/FM SELECT
27	V REF
28	POWER SUPPLY

BA4558: IC501

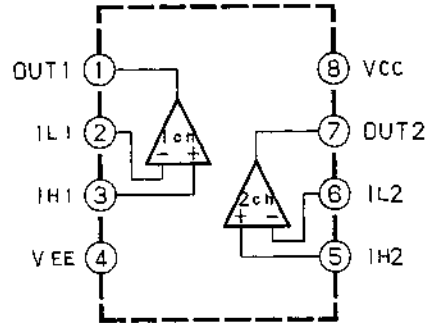
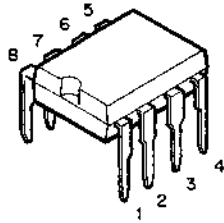

TD6352P: IC502 ●

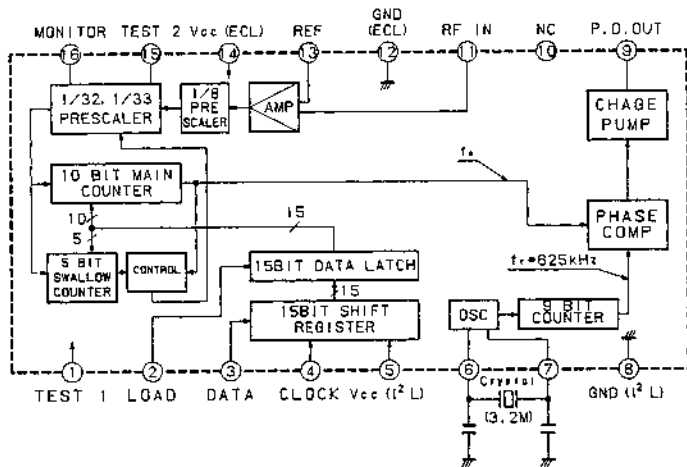
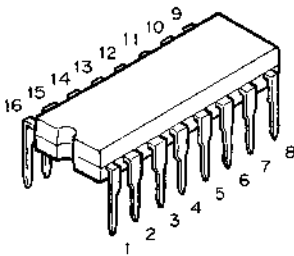

TC9173P: IC505

TC9174P: IC503 ●

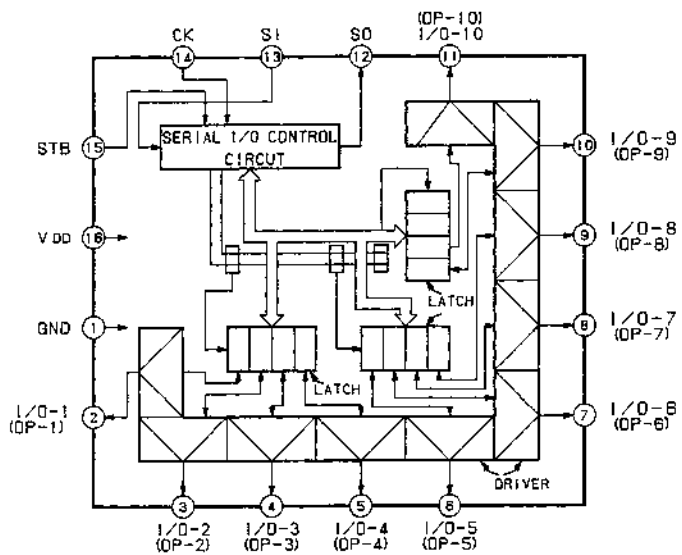
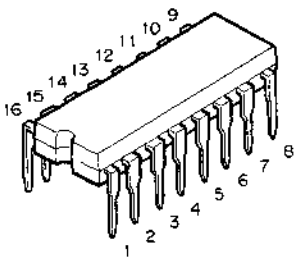

Note: ● : For Japanese model only (JA) ■ : For North American model only (UZ)
 ★ : For General Foreign model only (EK) ◆ : For West Germany model only (T-117L SD)
 ☆ : For General Foreign model only (T-03 EK) ◇ : For West Germany model only (T-03L SD) Others : Common

LM7000:IC504

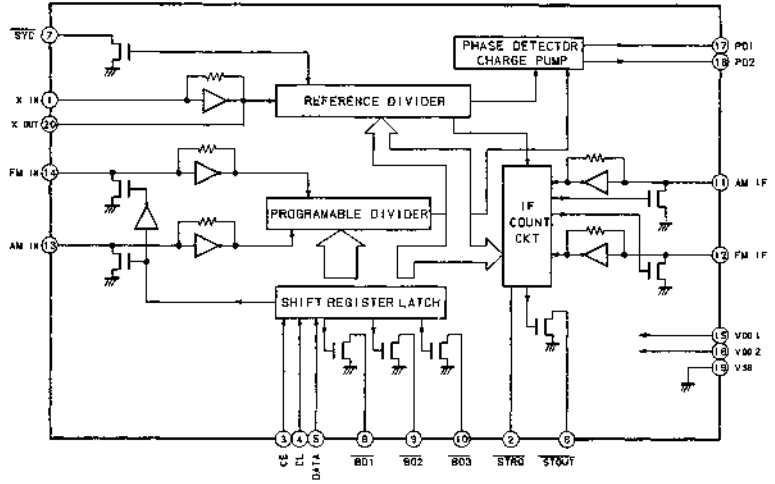
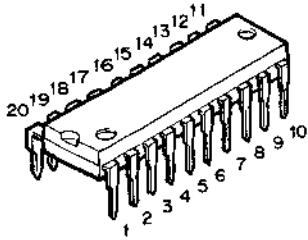

TC9306F:IC507 (1/2)

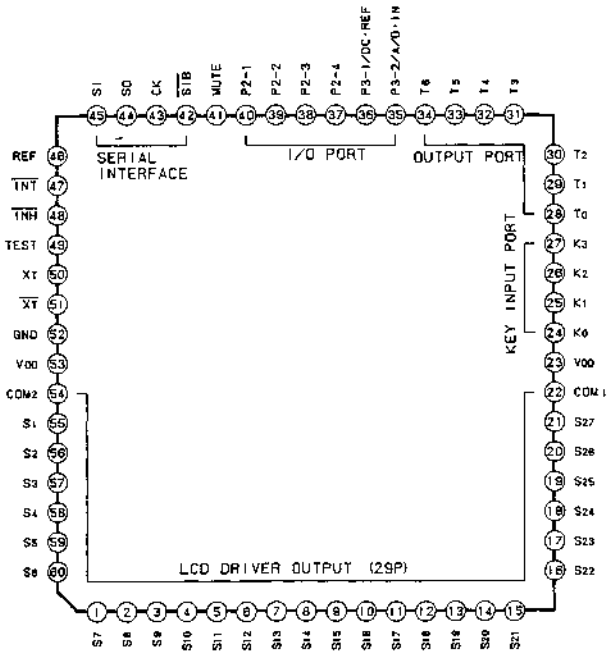
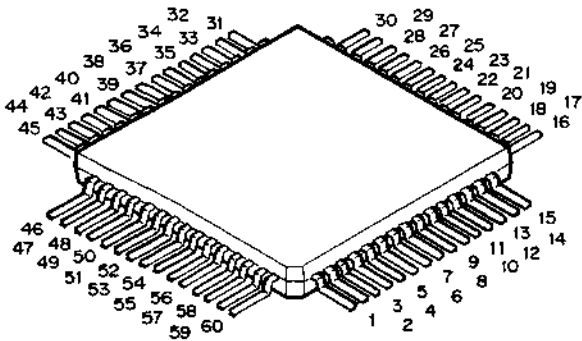

TC9306F:IC507 (2/2)

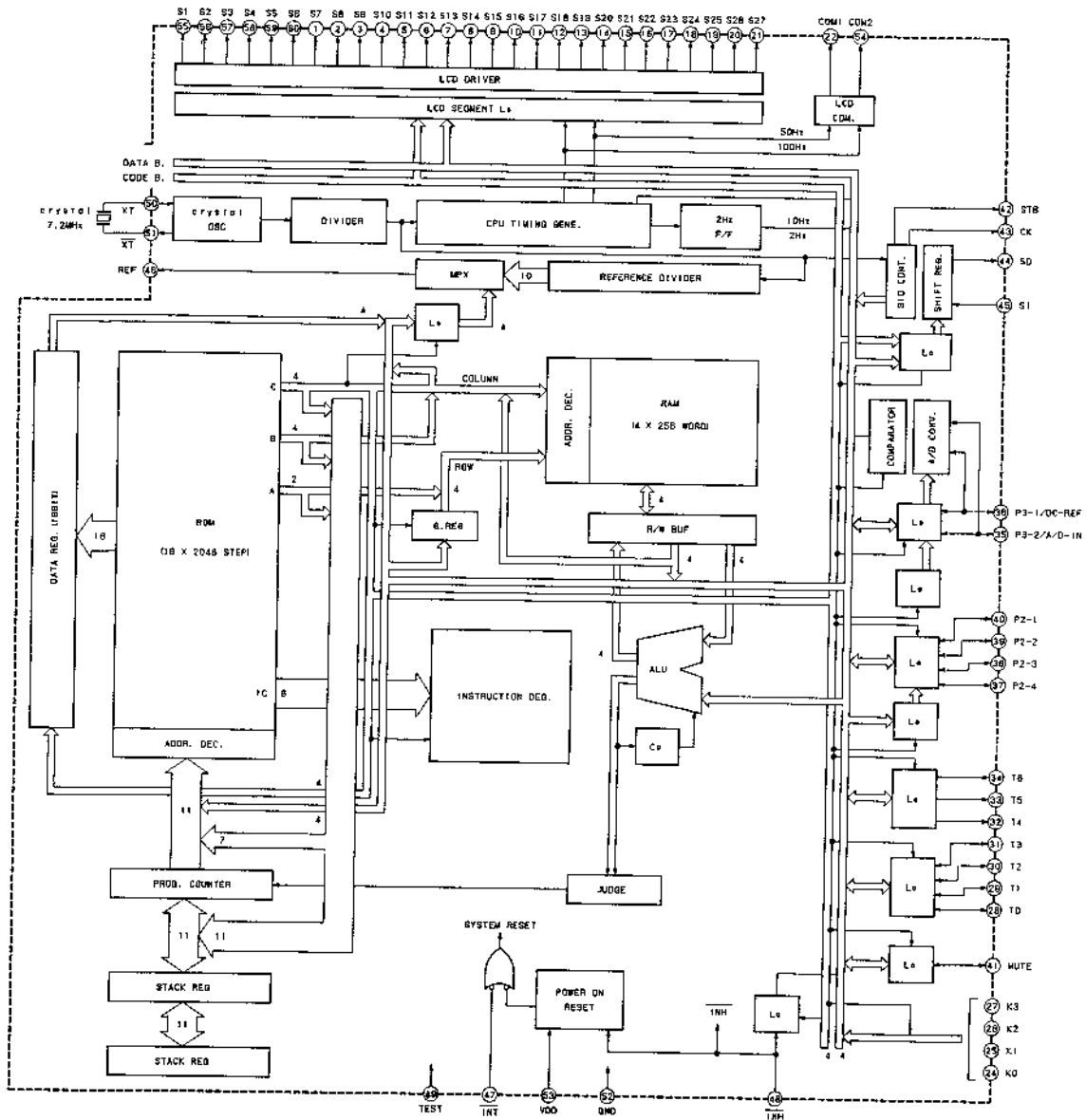

LA7905: IC601 ●

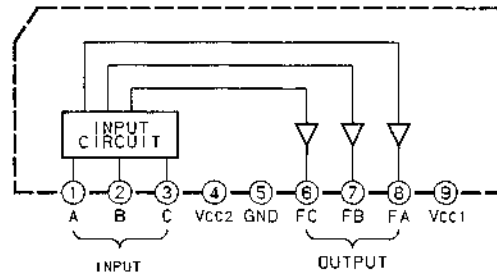
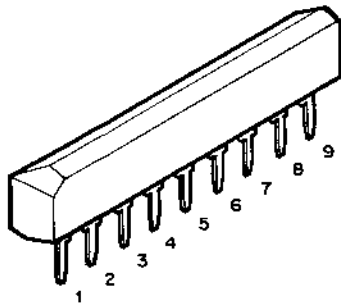

LA3801: IC701 ●

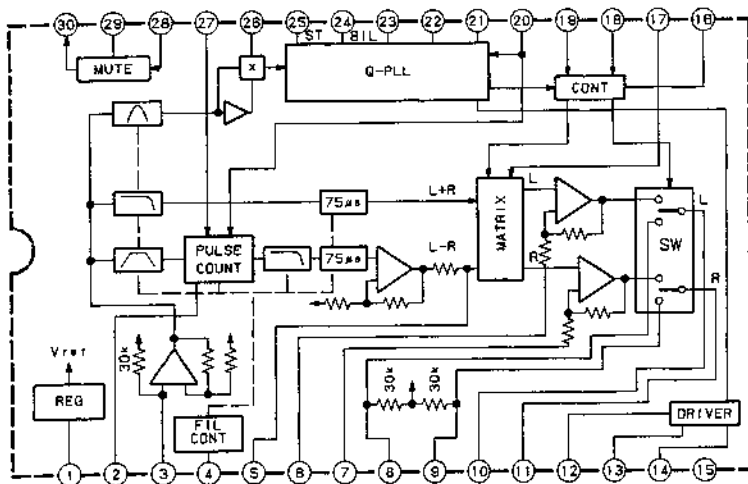
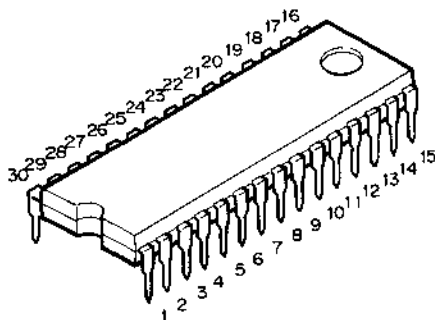

Pin No	DESCRIPTION
1	Vcc
2	PULSE COUNT BIAS
3	TV IN
4	FILTER ADJ.
5	SEPALATION ADJ.
6	L CH (MAIN) GAIN
7	R CH (SUB) GAIN
8	FM (L) IN
9	FM (R) IN
10	AM (L) OUT
11	AM (R) OUT
12	ST IND.
13	BIL. (MAIN) IND.
14	BIL. (SUB) IND.
15	GND
16	TV/FM
17	PALARTY
18	BIL. (MAIN)
19	BIL. (SUB)
20	VCO-STOP
21	CERAMIC FILTER
22	PLL LPF
23	PLL LPF
24	BIL. SYNCHRONOUS DETECTION LPF
25	ST SYNCHRONOUS DETECTION LPF
26	AM DETECTION LPF
27	PULSE COUNT LPF
28	MUTE IN
29	Vcc ON/OFF MUTE
30	MUTE DRIVE

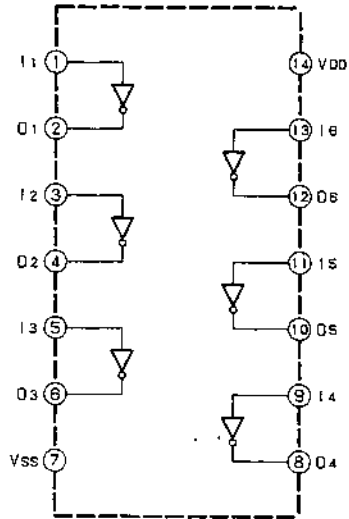
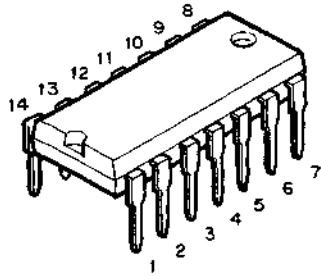

Note: ● : For Japanese model only (JA) ■ : For North American model only (UZ)
 ★ : For General Foreign model only (EK) ◆ : For Vest Germany model only (T-117L SD)
 ☆ : For General Foreign model only (T-03 EK) ◇ : For Vest Germany model only (T-03L SD) Others : Common

BU4069UB: 1C702



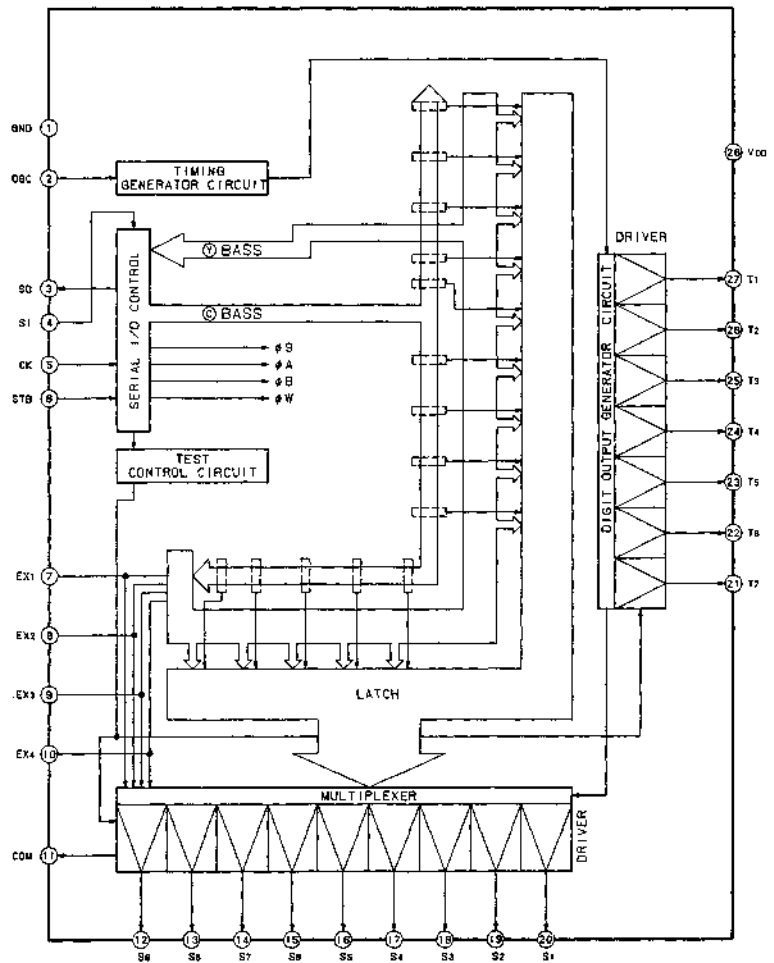
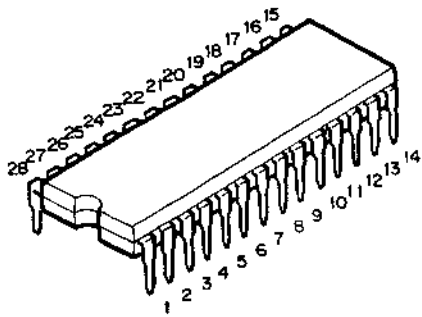

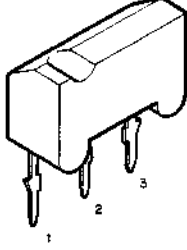
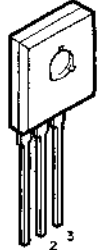
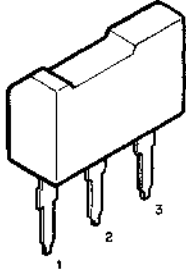
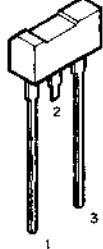
TC9190N: 1C901.902

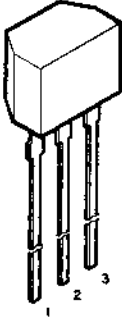

<p>2SD1330:Q1002</p>  <p>1. Emitter 2. Collector 3. Base</p>	<p>2SD1563:Q001●</p>  <p>1. Emitter 2. Collector 3. Base</p>
<p>2SD1225M:Q001 ☆★◇◆■</p>  <p>1. Emitter 2. Collector 3. Base</p>	<p>2SA1555AB:Q008,010,011●◇◇ 2SC4032AB:Q006,012,111●</p>  <p>1. Emitter/GND 2. Collector/OUT 3. Base/IN</p>
<p>2SA1015:Q1001,505 ●◇◇</p> <p>2SA1015: } Q116,308,404,411,501,503,504,217◇◇ 2SA933A: } Q307◇◇,801,116</p> <p>2SC1740: } Q002,003,004,005,007,009,015,104,105,107,108,109●,112,115,117,118●,210,211,212,213, 2SC1815: } Q214,302,305,306,405●,410,412●,502,203◇◇,215◇◇,216◇◇,301◇◇,401◇◇</p> <p>2SC1815:Q119,802</p> <p>2SC1674:Q206,207,208,303,601●,602●◇◇</p> <p>2SC1675:Q209,603●</p> <p>2SD1302:Q402,403,409</p>  <p>1. Emitter 2. Collector 3. Base</p>	

Note: ● : For Japanese model only (JA) ■ : For North American model only (UZ)
 ★ : For General Foreign model only (EX) ◆ : For West Germany model only (T-117L SD)
 ☆ : For General Foreign model only (T-03 EK) ◇ : For West Germany model only (T-03L SD) Others : Common

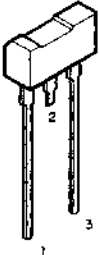
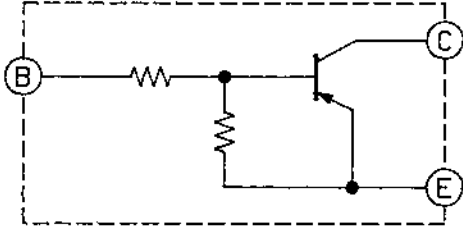
<p>2SK246:Q113.114.201.202.408</p>  <p>1. Source 2. Gate 3. Drain</p>	<p>2SK241:Q205</p>  <p>1. Drain 2. Source 3. Gate</p>
<p>2SK301:Q407●, 408●</p>  <p>1. Drain 2. Gate 3. Source</p>	
<p>DTA124EL:Q510■</p>  <p>1. Emitter 2. Collector 3. Base</p> 	

Note: ● : For Japanese model only (JA) ■ : For North American model only (UZ)
 ★ : For General Foreign model only (EK) ◆ : For West Germany model only (T-117L SD)
 ☆ : For General Foreign model only (T-03 EK) ◇ : For West Germany model only (T-03L SD) Others : Common

MEMO

A series of horizontal dashed lines for writing, spanning the width of the page.