

# SERVICE MANUAL

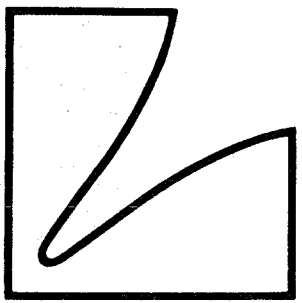

## FREQUENCY SYNTHESIZED AM FM STEREO TUNER T-230/T-230L/T-400

T-230/T-230L

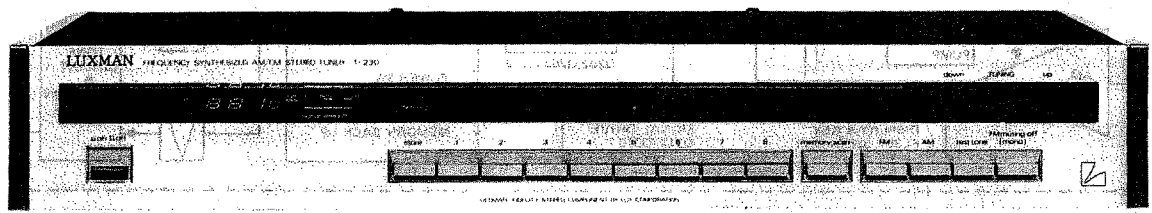

# Contents

Block Diagram .....	1
Adjustment Locations .....	2
Alignment Procedure .....	3
調整手順書 .....	4
Exploded View .....	5
Exploded View Parts List .....	6
Packing Material Parts List .....	7
Radio PCB Parts List .....	8, 9, 10, 11, 12
Synthesizer PCB Parts List .....	13, 14
Ass'y Power Trans PCB Parts List .....	15, 16
Memory PCB Parts List .....	16
Store PCB Parts List .....	17
UP&DOWN PCB Parts List .....	17
Destinations' Parts List (T-230) .....	18
Remarks .....	18
IC Handling Guide .....	19
Schematic Diagram(A) .....	20
Schematic Diagram(B) .....	21
Specifications .....	22
規格 .....	22

T-230/T-230L

## Block Diagram

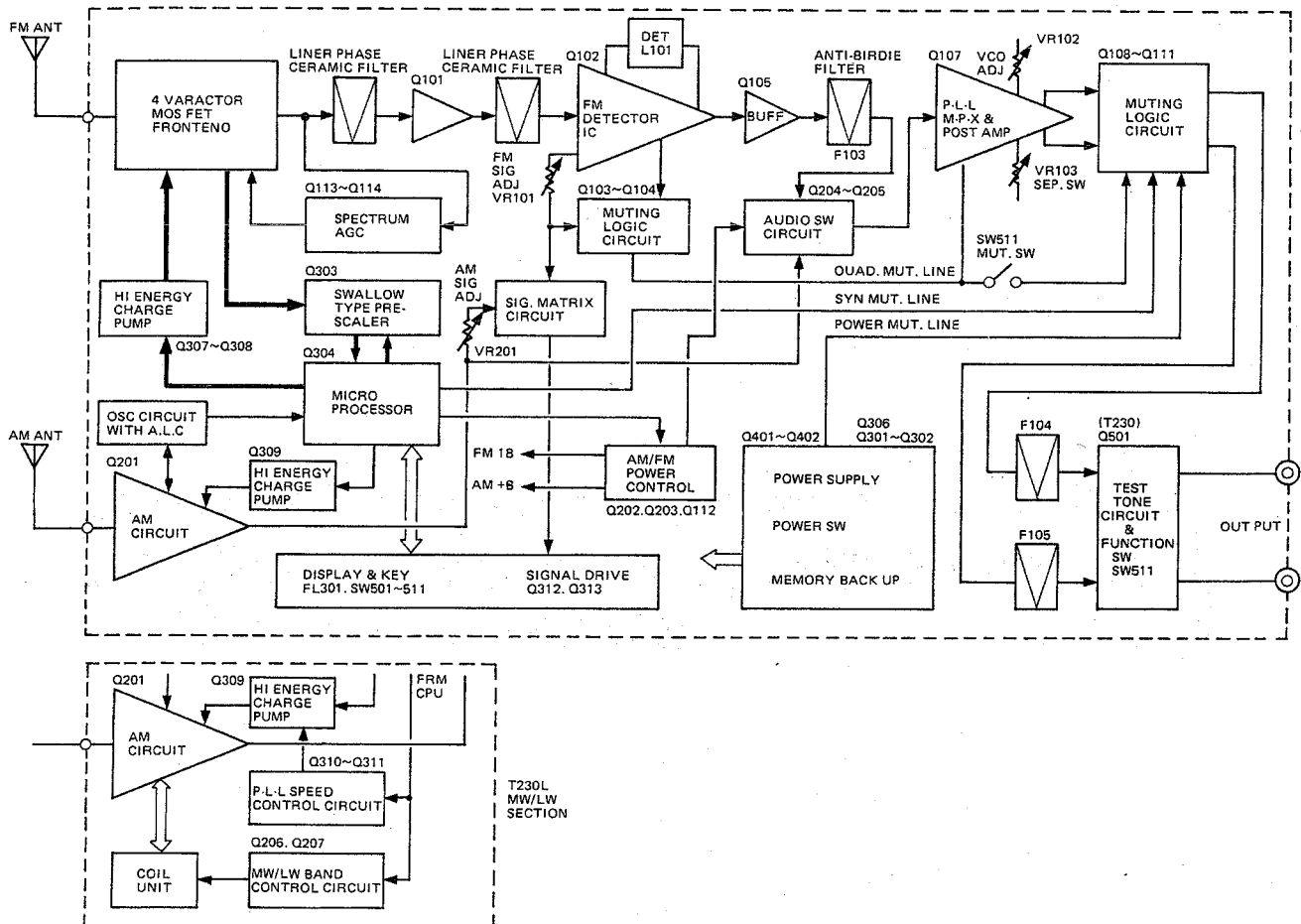

# Adjustment Locations

CP101	Check Pin	L101	FM DET
CP102	//	L201	LW OSC Coil (T-230L)
CP103	//	L202	AM OSC
CP104	//	L203	LW ANT Coil (T-230L)
CP105	//	L204	AM ANT
VR101	FM Muting	L205	AM IFT
VR102	VOC	L206	AM IFT
VR103	FM Stereo Separation	CT201	LW OSC Trimmer (T-230L)
VR201	AM Signal LED	CT202	AM OSC
VR501	Test Tone (T-230, T-400)	CT203	LW ANT Trimmer (T-230L)
IFT	FM Stereo Distortion	CT204	AM ANT

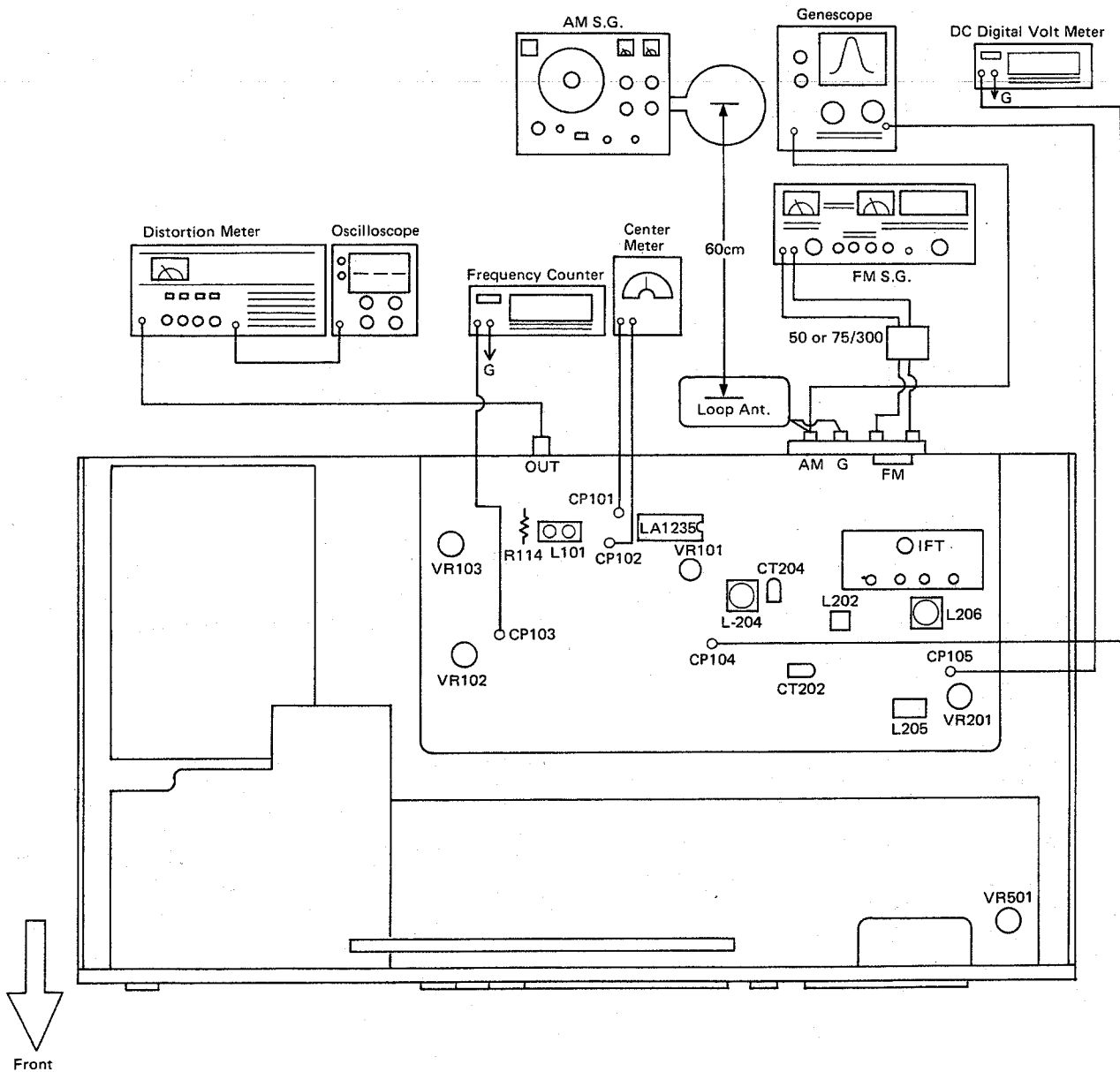

T-230/T-230L

# Alignment Procedure

Prior to each adjustment, set VR's and SW's as follows:

1. Muting Off Sw: Depressed
2. Test Tone Sw: Extruded
3. VR101 (FM Muting): Center position
4. VR102 (VCO): //
5. VR103 (FM Separation): //
6. VR201 (AM Signal): //

## 1) AM Section

1. Set the function SW at AM.
2. Connect input and output of the sweep generator to CP105 and AM ANT. Terminal respectively. (Make output of the generator scope 20 to 50dB, watching the waveform to set the value.)
3. Adjust L205 and L206 to obtain a flat and symmetric and single-peak waveform at 450KHz.
4. Connect a digital voltmeter in between CP104 and the ground.
5. Adjust L202 and CT202 to obtain 2.0V at 603KHz and 7V at 1404KHz. Repeat this procedure 2 or 3 times to obtain the designated value.
6. Make the receiving frequency 603KHz (American Type 600KHz) and send signal of 60dB/M, 603KHz (American Type 600KHz) 400Hz 30% modulation from the signal generator through the loop antenna and adjust L204 to obtain the maximum output, connecting the indicated loop antenna to the unit.
7. Make the receiving frequency 1404KHz (American Type 1400KHz) and send signal of 1404KHz (American Type 1400KHz) from the signal generator same as the above procedure 6 and adjust CT204 to obtain the maximum output.
8. Repeat the procedures. 6 & 7, 2 or 3 times and adjust to obtain the maximum output respectively at 603KHz (American Type 600 KHz) and 1404KHz (American Type 1400KHz). Then, confirm at 1088KHz to meet the specs on the separate sheep.
9. Adjust VR201 to make 5 dots of the signal strength FL light at 1008KHz, 400Hz 30% modulation, 80dB/M.
10. Confirm that the receiving frequency range remains within the following; 522KHz—1611KHz.

## 2) LW Section

1. In case of the T-230L, following should be additionally done; Connect a digital voltmeter to CP104 and adjust L201 and CT201 to obtain 155KHz, 2.0V and 481KHz, 7.0V respectively.
2. Adjust L203 to obtain the maximum output, receiving the output of 182KHz, 400Hz, 30% modulation, 65dB/M from the signal generator.
3. Adjust CT203 to obtain the maximum output, receiving the output of 264KHz, 400Hz, 30% modulation, 65dB/M from the signal generator.
4. Receive the signal of 227KHz, 400Hz, 30% modulation and confirm to meet the specs on the separate sheep.
5. Confirm that the receiving frequency range remains within the following: 155KHz—281KHz.

## 3) FM Section

1. Set the function SW at FM.
2. Set the signal generator at 98.1MHz, mono, 1KHz 100% modulation, 3mV output and tune the unit at 98.1MHz.
3. Connect the center meter to CP101 and CP102 and adjust the primary core of L101 (which is close to LA1235) to make the center meter read 'zero'.
4. Make the output of the signal generator about 1-2uV and adjust frequency of the signal generator to make the waveform virtually symmetric on its peak and according to the adjusted frequency cut off the diode on the synthesizer P. C. B. as per indication mentioned below:
  - a) about -25KHz D305, D306
  - b) about -50KHz D306
  - c) about +25KHz D305
  - d) about +50KHz non
  - e) within  $\pm 10$ KHz non
5. Make the output of the signal generator 3mV again and adjust the secondary core of L101 (close to R114) to make distortion minimum and the primary core of L101 to make the center meter read 'zero' respectively. Repeat this procedure 2 or 3 times.
6. Make the muting off SW extruded and adjust VR101 to make the waveform appear perfectly at 5uV output from the signal generator. Also confirm that the indication FL of the center meter is lit.
7. Confirm that the dots of the signal strength FL are gradually lit when output of the signal generator is increased and that 5 dots are lit at about 1mV output.
8. Connect a frequency counter in between CP103 and the chassis of the unit and adjust VR102 to obtain 76KHz $\pm$ 10Hz.
9. Set the signal generator at Stereo L or R modulation (1KHz) with output of 3mV. At this time confirm the stereo indication FL is lit. (While also confirm that the stereo indication FL is unlit when the Mono SW is depressed.)
10. Turn the IFT of the front-end to make stereo distortion minimum, after which confirm the above step 5 & 6 and if those are off the points, readjust.
11. Adjust VR103 to obtain stereo separation at more than 45dB on both channels balanced.
12. Adjust VR501 to obtain output of -6dB at output voltage of Mono 1KHz when the test tone SW is depressed.
13. Confirm that the receiving frequency range remains from 87.50MHz to 108.00MHz.

## 調整手順書

各調整に入る前に、VR、SWを下記の状態にしておく。

1. Muting off SW：押し込んだ状態
2. Test tone SW：飛び出した状態
3. VR101 (FM Muting)：中央
4. VR102 (VCO)：中央
5. VR103 (FM Separation)：中央
6. VR201 (AM Signal)：中央

### <AM>

1. Function SWをAMにする。
2. スイープジェネレーターの入出力をそれぞれCP105とAM ANT.ターミナルに接続する。
3. L205、L206でそれぞれ450KHzで平坦かつ単峰特性が得られる様に調整する。
4. CP104対アース間に、デジタルボルトメーター (DCV) を接続する。
5. 603KHzで2.0V、1404KHzで7Vとなる様に、それぞれL202、CT202で調整する。この操作を指定値になる様に2～3度繰り返す。
6. セットの受信周波数を603KHzにし、SGから60dB/m、603KHz、400Hz、30%mod.の信号をループアンテナを用いて送り、セットに指定のループアンテナをつなぎ、最高出力が得られる様にL204を調整する。
7. セットの受信周波数を、1404KHzにし、SGから1404KHzの信号を6と同様に送信し、最高出力が得られる様にCT204を調整する。
8. 6、7. を2～3度繰り返し、603KHz、1404KHzでそれぞれ最高出力が得られる様にした後、1008KHzにし、それぞれのスペックを満足する事を確認する。
9. 1008KHz、400Hz、30%mod、80dB/mでSignal Strength FLが5灯点灯する様にVR201を調整する。
10. 受信周波数範囲が522KHz～1611KHzの範囲内である事を確認する。

### <FM>

1. Function SWをFMにする。
2. FM、SGを84MHz、mono、1KHz、100%mod、3mV、出力とする。セットをそれぞれ84MHzにする。
3. センタメーターをCP101、CP102につなぎ、L101の一次コア (LA1235に近い方) でセンタメーターの指示を零に合わせる。
4. 次にSGの出力を $1\mu\sim 2\mu\text{V}$ 程度にし、波形のつぶれ方が上下対称となる様にSGの周波数をずらせる。ずらせた周波数により、シンセサイザー基板上のダイオードを指示通りカットする。

(a) -25KHz	程度	D305
(b) -50KHz	程度	—
(c) +25KHz	程度	D305、D306
(d) +50KHz	程度	D306
(e) $\pm 10\text{KHz}$	以内	—
5. 再度SG出力を3mVにし、L101の二次側のコア (R114側) を回して歪が最小になる様に、またL101の一次側コアを回してセンタメーターが零になる様、2～3度繰り返す。
6. Muting off SWを飛び出した状態にし、SG出力 $5\mu\text{V}$ で波形が、完全に出る様に、VR101を調整する。この時、センターIND. FLが点灯している事も、確認の事。
7. SG出力をすだいに上げて行った時、Signal Strength FLが1個、2個……と点灯する事をさらに1mV前後で5灯点灯する事を確認する。
8. CP103とシャーシ間に、周波数カウンターを持続し、VR102で76KHz、 $\pm 10\text{Hz}$ になる様に調整する。
9. SGをstereo L or R変調 (1KHz) し、出力を3mVとする。この時、stereo IND. FLが点灯している事を確認する。(またmono SWを押し込めばFLが消灯する事を確認する)
10. stereo歪が最小となる様に、フロントエンドのIFTを回す。その後、5、6. を再確認し、ずれていれば再調整する。
11. Stereo Separationが両CHとも、バランスに45dB以上とれる様にVR103を調整する。
12. Test tone SWを押し込んだ時、mono 1KHzの出力電圧の-6dBの出力となる様に、VR501を調整する。
13. 受信範囲が76.1MHz～89.9MHzの範囲内である事を確認する。

# Exploded View

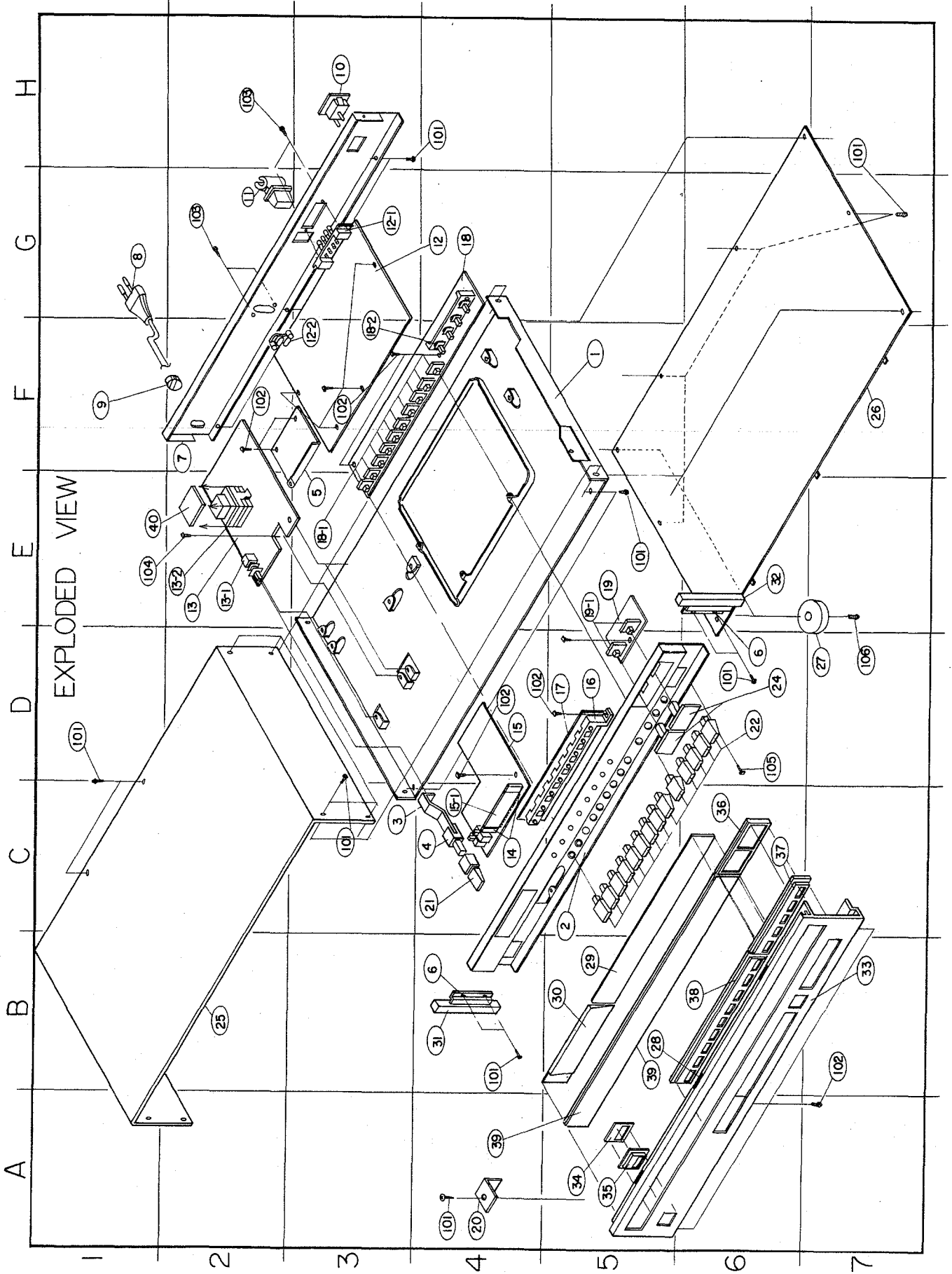

1000 17000 L

# Exploded View Parts List

Index	Symbol No.	T-230 Stock No.	T-230L Stock No.	T-400 Stock No.	Description
F5	1	27D56857F01	27D56857F01	27D56857F01	Chas, Main
B4	2	27D57284F01	27D57284F01	27D57284F01	Chas, Front
C4	3	45A57292F01	45A57292F01	45A57292F01	Lever, Knob
C4	4	45B56865F01	45B56865F01	45B56865F01	Lever, Knob 1223
E3	5	07A57316F01	07A57316F01	07A57316F01	Bkt, PCB
C4, E5	6	07A58271F01	07A58271F01	07A58271F01	Bkt, Side Panel
F1	7	15C56858F03	15C56858F07	15C56858F08	Cover, Rear (A, S)
		15C56858F04	Non Use	Non Use	Cover, Rear (UP)
C1	8	28T43812P04	28T43812P04	28T43851U01	Cord, AC Plug (A, S)
		28T55335F01	Non Use	Non Use	Cord, AC Plug (UP)
F1	9	43B41625J02	43B41625J02	43B41625J02	Suppor, Cord
H3	10	09T51080F01	09T51080F01	Non Use	Connector, ANT (A, S)
H2	11	55T51079F01	55T51079F01	55T51079F01	Lock, ANT. Holder
G4	12	01V58500F74	01V58700F97	01V58700F87	Ass'y, Radio P. C. B. (A, S)
		01V59200F99	Non Use	Non Use	Ass'y, Radio PCB (UP)
G3	12-1	09T51122F01	09T51122F01	09T51122F01	Terminal, ANT
F2	12-2	09T50231F01	09T50231F01	09T50231F01	Plate, Phone 2P
E2	13	01V58500F75	01V58700F98	01V58700F88	Ass'y, Power Trans (A, S)
		01V59300F01	Non Use	Non Use	Ass'y, Power Trans (UP)
E2	13-1	40T57645F01	40T57645F01	40T57645F01	SW, Push SUF12 (Short)
E2	13-2	25T57254F01	25T57254F01	25T57254F02	Power, Trans (A, S)
		25T57254F04	Non Use	Non Use	Power, Trans (UP)
C4	14	15A57286F01	15A57286F01	15A57286F01	Cover, 1052
C4	15	01V58500F76	01V58700F99	01V58700F89	Ass'y, SYN. P. C. B. (A, S)
		01V59300F02	Non Use	Non Use	Ass'y, SYN. P. C. B. (UP)
C4	15-1	65T53335F01	65T53335F01	65T53335F01	FL Meter FIP8RM4
C5	16	07B57285F01	07B57285F01	07B57285F01	Frame, LED
C5	17	01V58500F77	01V58500F77	01V58500F77	Ass'y, Memory P. C. B.
F4	18	01V58500F78	01V58800F01	01V58700F90	Ass'y, Store P. C. B.
F3	18-1	40T51081F01	45T51081F01	40T51081F01	SW, Tact
F4	18-2	40T57065F01	40T57064F01	40T57065F01	SW, Push SUL-4Key
E5	19	01V58500F79	01V58500F79	01V58500F79	Ass'y, UP & DOWN P. C. B.
E5	19-1	40T51081F01	40T51081F01	40T51081F01	SW, Tact
A5	20	07A57945F01	07A57945F01	07A57945F01	Bkt, 1400
C4	21	36A56639F02	36A56639F02	36A56639F02	Knob, push 1171
D6	22	36A56640F01	36A56640F01	36A56640F01	Knob, Push 1189
C5	23	36A57277F01	36A57277F01	36A57277F01	Knob, Push 1195
C6	24	36A57278F01	36A57278F01	36A57278F01	Knob, Push 1196
C2	25	15C56855F01	15C56855F01	15C56855F01	Cover, Top
F7	26	15B56856F01	15B56856F01	15B56856F01	Cover, Bottom
E7	27	75A52969F01	75A52969F01	75A52969F01	Pad, Trann-Leg
B6	28	14S53018F42	14S53018F42	14S53018F42	Insulator, 50X5
B5	29	61B57283F01	61B57283F01	61B57283F01	Crystal, IND. 1072
B4	30	61B57737F01	61B57737F01	61B57737F01	Crystal, IND. 1073
B4	31	07B56848F01	07B56848F01	07B56848F01	Frame, Panel Side L
E6	32	07B56849F01	07B56849F01	07B56849F01	Frame, Panel Side R
B7	33	64C57276F01	64C57276F02	64C57276F03	Panel, Front
A5	34	61A56641F01	61A56641F01	61A56641F01	Crystal, Indicator
A5	35	43A56628F01	43A56628F01	43A56628F01	Spacer, Power
C6	36	07B57279F01	07B57279F01	07B57279F01	Frame, Knob 1159
B4, C6	37	07B57280F01	07B57280F01	07B57280F01	Frame, Knob 1160
B5	38	07B57281F01	07B57281F01	07B57281F01	Frame, Knob 1161
C7	39	61B57282F01	61B57282F01	61B57282F01	Crystal, IND. 1122
E2	40	43A58041F01	43A58041F01	43A58041F01	SPacer, 1195
A2, B4	101	03S44205G01	03S44205G01	03S44205G01	Scr, T-Tite M3X8
E4, F2	102	03C42723U01	03C42723U01	03C42723U01	Scr, Cup M3X6
G2	103	03S40012G41	03S40012G41	03S40012G41	Scr, TPG M3X8
E2	104	03S40036U02	03S40036U02	03S40036U02	Scr, T-Tite M3X8
C6	105	03C40014G04	03C40014G04	03C40014G04	Scr, MCH M3X6
E7	106	03S40036U10	03S40036U10	03S40036U10	Scr, T-Tite M3X10

T-230/T-230L

# Packing Material Parts List

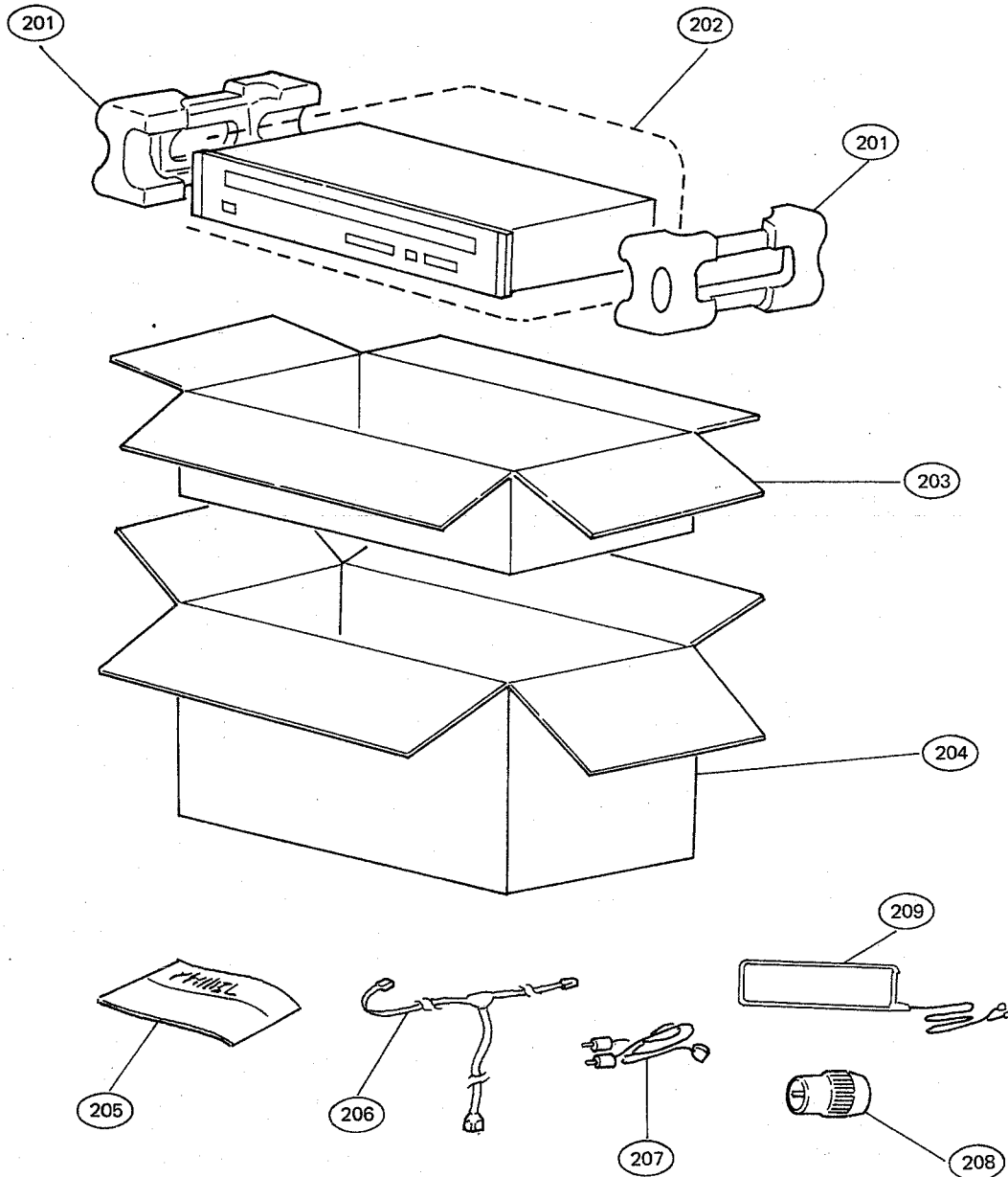

T-230/T-230L

Symble No.	T-230 Stock No.	T-230L Stock No.	T-400 Stock No.	Description
201	56D56866F01	56D56866F01	56D56866F01	PKG. Tray
202	56B40230G34	56B40230G34	56B40230G34	Sack. Poly
203	56C53420F41	56C53420F45	56C53420F46	Carton, PKG
204	56C53420F31	56C53420F31	Non Use	Carton, Bluk PKG
205	ME0251	ME0251	MA0162	Manual
206	85T51069F01	85T51069F01	85T53411F01	Antenna, FM
207	28C42374J02	28C42374J02	28C42374J02	Cord, Output
208	28T51066F01	28T51066F01	Non Use	Plug, Antenna (A, S)
209	85T51078F01	85T51078F01	85T51078F01	Antenna, Loop



# Radio PCB Parts List

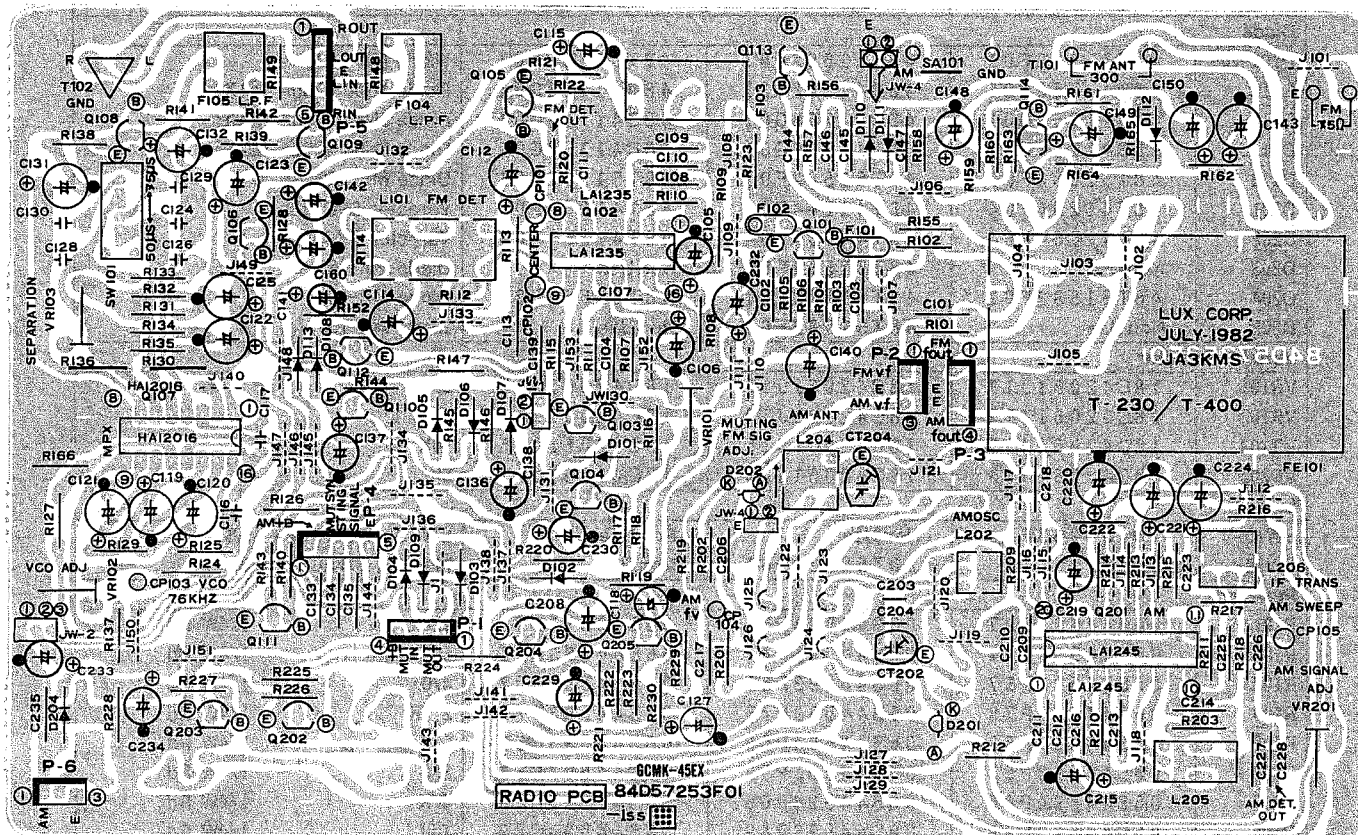

T-230/T-230L

Symble No.	T-230 Stock No.	T-230L Stock No.	T-400 Stock No.	Description
<b>Front End</b>				
FE101	77T51132F01	77T51132F01	77T53422F01	Front End
<b>Terminal</b>				
T101	09T51122F01	09T51122F01	09T51122F01	Terminal, ANT
T102	09T50231F01	09T50231F01	09T50231F01	Plate, P phone 2P
<b>Filter</b>				
F101	91T51130F01	91T51130F01	91T51130F01	Filter, CER SFE 10.7MM
F102	91T51130F01	91T51130F01	91T51130F01	Filter, CER SFE 10.7MM
F103	91T51083F01	91T51083F01	91T51083F01	Filter, Anti Birdy
F104	91T51124F01	91T51124F01	91T51124F01	Filter, MPX LA1209 (A, S)
F105	91T53325F01	Non Use	Non Use	Filter, LA1196 (U, P)
	91T51124F01	91T51124F01	91T51124F01	Filter, MPX LA1209 (A, S)
	91T53325F01	Non Use	Non Use	Filter, LA1196 (U, P)
<b>Coil</b>				
L101	24T51128F01	24T51128F01	24T51128F01	Trans, FM DET LA1457
L201	Non Use	24T57627F01	Non Use	Coil, LW OSC
L202	24T53326F01	24T53326F01	24T53326F01	Trans, AM OSC
L203	Non Use	24T56892F01	Non Use	Coil, LW ANT
L204	24T51125F01	24T51125F01	24T51125F01	Trans, ANT (AM) LA1210
L205	24T51126F01	24T51126F01	24T51126F01	Trans, IF (450KHz)
L206	24T53327F01	24T53327F01	24T53327F01	Trans, IF
<b>Trimmer</b>				
CT201	Non Use	20T47503F02	Non Use	TZ03 (RED)
CT202	20T47503F02	20T47503F02	20T47503F02	TZ03 (RED)
CT203	Non Use	20T47503F02	Non Use	TZ03 (RED)
CT204	20T47503F02	20T47503F02	20T47503F02	TZ03 (RED)

Symble No.	T-230 Stock No.	T-230L Stock No.	T-400 Stock No.	Description	
<b>Diode</b>					
D101-109	48T51582F01	48T51582F01	48T51582F01	Diode MA-150	
D110	48B41768G01	48B41768G01	48B41768G01	Diode 1N60 (75uA MAX)	
D111	48B41768G01	48B41768G01	48B41768G01	Diode 1N60 (75uA MAX)	
D112	48B41768G01	48B41768G01	48B41768G01	Diode 1N60 (75uA MAX)	
D113	48T51582F01	48T51582F01	48T51582F01	Diode MA-150	
D201	48T41264F04	48T41264F04	48T41264F04	Varactor SVC321A	
D202	48T41264F04	48T41264F04	48T41264F04	Varactor SVC321A	
D203	Non Use	48T51582F01	Non Use	Diode MA-150	
D204	48T51582F01	48T51582F01	48T51582F01	Diode MA-150	
D205	Non Use	48T51582F01	Non Use	Diode MA-150	
<b>Variable Resistor</b>					
VR101	18C42061J13	18C42061J13	18C42061J13	5K	
VR102	18C42061J12	18C42061J12	18C42061J12	2K	
VR103	18C42061J15	18C42061J15	18C42061J15	50K	
VR201	18C42061J13	18C42061J13	18C42061J13	5K	
<b>Switch</b>					
SW101	40T51963F01	Non Use	Non Use	SW, Slide SW343-1 (AS)	
SW201	Non Use	80T52120F01	Non Use	Magnet, SWE016401-S	
<b>Resistor</b>					
R101	06S44593P97	06S44593P97	06S44593P97	22K	1/4W Rd
R102	06S44593P41	06S44593P41	06S44593P41	100	1/4W Rd
R103	06S44593P57	06S44593P57	06S44593P57	470	1/4W Rd
R104	06S44593P75	06S44593P75	06S44593P75	2.7K	1/4W Rd
R105	06S44593P53	06S44593P53	06S44593P53	330	1/4W Rd
R106	06S44593P53	06S44593P53	06S44593P53	330	1/4W Rd
R107	06S44594P06	06S44594P06	06S44594P06	47K	1/4W Rd
R108	06S44593P89	06S44593P89	06S44593P89	10K	1/4W Rd
R109	06S44594P12	06S44594P12	06S44594P12	82K	1/4W Rd
R110	06S44593P53	06S44593P53	06S44593P53	330	1/4W Rd
R111	06S44593P41	06S44593P41	06S44593P41	100	1/4W Rd
R112	06S44593P83	06S44593P83	06S44593P83	5.6K	1/4W Rd
R113	06S44593P95	06S44593P95	06S44593P95	18K	1/4W Rd
R114	06S44593P73	06S44593P73	06S44593P73	2.2K	1/4W Rd
R115	06S44593P81	06S44593P81	06S44593P81	4.7K	1/4W Rd
R116	06S44593P81	06S44593P81	06S44593P81	4.7K	1/4W Rd
R117	06S44593P89	06S44593P89	06S44593P89	10K	1/4W Rd
R118	06S44594P06	06S44594P06	06S44594P06	47K	1/4W Rd
R119	06S44594P06	06S44594P06	06S44594P06	47K	1/4W Rd
R120	06S44593P41	06S44593P41	06S44593P41	100	1/4W Rd
R121	06S44593P89	Non Use	Non Use	10K	1/4W Rd
	Non Use	06S44593P87	06S44593P87	8.2K	1/4W Rd
R122	06S44593P73	06S44593P73	06S44593P73	2.2K	1/4W Rd
R123	06S44593P89	06S44593P89	06S44593P89	10K	1/4W Rd
R124	06S44594P22	Non Use	Non Use	220K	1/4W Rd
	Non Use	06S44594P14	06S44594P14	100K	1/4W Rd
R125	06S44593P83	Non Use	Non Use	5.6K	1/4W Rd
	Non Use	06S44593P85	06S44593P85	6.8K	1/4W Rd
R127	06S44593P89	06S44593P89	06S44593P89	10K	1/4W Rd
R128	06S44593P81	06S44593P81	06S44593P81	4.7K	1/4W Rd
R129	06S44593P65	06S44593P65	06S44593P65	1K	1/4W Rd
R130	06S44593P99	06S44593P99	06S44593P99	27K	1/4W Rd
R131	06S44593P71	06S44593P71	06S44593P71	1.8K	1/4W Rd
R132	06S44594P06	06S44594P06	06S44594P06	47K	1/4W Rd
R133	06S44593P53	06S44593P53	06S44593P53	330	1/4W Rd
R134	06S44593P71	06S44593P71	06S44593P71	1.8K	1/4W Rd
R135	06S44593P99	06S44593P99	06S44593P99	27K	1/4W Rd
R136	06S44594P06	06S44594P06	06S44594P06	47K	1/4W Rd
R137	06S44593P89	06S44593P89	06S44593P89	10K	1/4W Rd
R138	06S44593P77	06S44593P77	06S44593P77	3.3K	1/4W Rd

T-230/T-230L

T-230/T-230I

Symble No.	T-230 Stock No.	T-230L Stock No.	T-400 Stock No.	Description	
R139	06S44593P77	06S44593P77	06S44593P77	3.3K	1/4W Rd
R140	06S44594P06	06S44594P06	06S44594P06	47K	1/4W Rd
R141	06S44593P97	06S44593P97	06S44593P97	22K	1/4W Rd
R142	06S44593P97	06S44593P97	06S44593P97	22K	1/4W Rd
R143	06S44594P06	06S44594P06	06S44594P06	47K	1/4W Rd (A, S)
	06S44593P97	Non Use	Non Use	22K	1/4W Rd (UP)
R144	06S44594P14	06S44594P14	06S44594P14	100K	1/4W Rd
R145	06S44594P06	06S44594P06	06S44594P06	47K	1/4W Rd
R146	06S44594P30	06S44594P30	06S44594P30	470K	1/4W Rd
R147	06S4459P14	06S44594P14	06S44594P14	100K	1/4W Rd
R148	06S44593P77	06S44593P77	06S44593P77	3.3K	1/4W Rd
R149	06S44593P77	06S44593P77	06S44593P77	3.3K	1/4W Rd
R150	Non Use	06S44593P41	Non Use	100	1/4W Rd
R151	Non Use	06S44593P41	Non Use	100	1/4W Rd
R152	06S44593P81	06S44593P81	06S44593P81	4.7K	1/4W Rd
R153	Non Use	Non Use	06S44593P93	15K	1/4W Rd
R154	Non Use	Non use	06S44593P99	47K	1/4W Rd
R155	06S44593P69	06S44593P69	06S44593P69	1.5K	1/4W Rd
R156	06S44594P26	06S44594P26	06S44594P26	330K	1/4W Rd
R157	06S44593P77	06S44593P77	06S44593P77	3.3K	1/4W Rd
R158	06S44594P14	06S44594P14	06S44594P14	100K	1/4W Rd
R159	06S44593P75	06S44593P75	06S44593P75	2.7K	1/4W Rd
R160	06S44594P30	06S44594P30	06S44594P30	470K	1/4W Rd
R161	06S44594P06	06S44594P06	06S44594P06	47K	1/4W Rd
R162	06S44594P02	06S44594P02	06S44594P02	33K	1/4W Rd
R163	06S44593P77	06S44593P77	06S44593P77	3.3K	1/4W Rd
R164	06S44594P12	06S44594P12	06S44594P12	82K	1/4W Rd
R165	06S44594P02	06S44594P02	06S44594P02	33K	1/4W Rd
R166	06S44594P02	06S44594P02	06S44594P02	33K	1/4W Rd
R190	06S44593P49	Non Use	Non Use	220	1/4W Rd (UP)
R202	06S44594P14	06S44594P14	06S44594P14	100K	1/4W Rd
R202	06S44594P30	06S44594P30	06S44594P30	470K	1/4W Rd
R203	06S44593P89	06S44593P89	06S44593P89	10K	1/4W Rd
R204	Non Use	06S44593P89	Non Use	10K	1/4W Rd
R205	Non Use	06S44593P95	Non Use	22K	1/4W Rd
R206	Non Use	06T55177F59	Non Use	560	1W Rf
R207	Non Use	06S44594P02	Non Use	47K	1/4W Rd
R208	Non Use	06S44593P89	Non Use	10K	1/4W Rd
R209	06S44593P41	06S44593P41	06S44593P41	100	1/4W Rd
R210	06S44593P69	06S44593P69	06S44593P69	1.5K	1/4W Rd
R211	06S44593P57	06S44593P57	06S44593P57	470	1/4W Rd
R212	06S44593P41	06S44593P41	06S44593P41	100	1/4W Rd
R213	06S44593P53	06S44593P53	06S44593P53	330	1/4W Rd
R214	06S44593P89	06S44593P89	06S44593P89	10K	1/4W Rd
R215	06S44593P89	06S44593P89	06S44593P89	10K	1/4W Rd
R216	06S44593P41	06S44593P41	06S44593P41	100	1/4W Rd
R217	06S44593P75	06S44593P75	06S44593P75	2.7K	1/4W Rd
R218	06S44593P99	06S44593P99	06S44593P99	27K	1/4W Rd
R219	06S44593P89	06S44593P89	06S44593P89	10K	1/4W Rd
R220	06S44593P89	06S44593P89	06S44593P89	10K	1/4W Rd
R221	06S44594P02	06S44594P02	06S44594P02	33K	1/4W Rd
R222	06S44594P02	06S44594P02	06S44594P02	33K	1/4W Rd
R223	06S44593P73	06S44593P73	06S44593P73	2.2K	1/4W Rd
R224	06S44593P65	06S44593P65	06S44593P65	1K	1/4W Rd
R225	06S44593P65	06S44593P65	06S44593P65	1K	1/4W Rd
R226	06S44593P85	06S44593P85	06S44593P85	6.8K	1/4W Rd
R227	06S44594P06	06S44594P06	06S44594P06	47K	1/4W Rd
R228	06S44594P06	06S44594P06	06S44594P06	47K	1/4W Rd

Symble No.	T-230 Stock No.	T-230L Stock No.	T-400 Stock No.	Description	
R229	06S44594P24	06S44594P24	06S44594P24	270K	1/4W Rd
R230	06S44594P22	06S44594P22	06S44594P22	220K	1/4W Rd
(Capacitor)					
C101	08S44505P61	08S44505P61	08S44505P61	10000pF	Ce
C102					
-104	08S44505P63	08S44505P63	08S44505P63	22000pF	Ce
C105	23T51235F01	23T51235F01	23T51235F01	0.47uF	50V E1
C106	23T51235F11	23T51235F11	23T51235F11	4.7uF	25V E1
C107					
-110	08S44505P63	08S44505P63	08S44505P63	22000pF	Ce
C111	08S44505P37	08S44505P37	08S44505P37	100pF	Ce
C112	23T51235F03	23T51235F03	23T51235F03	1uF	50V E1
C113	08S44505P63	08S44505P63	08S44505P63	22000pF	Ce
C114	23T51235F44	23T51235F44	23T51235F44	100uF	16V E1
C115	23T51235F38	23T51235F38	23T51235F38	47uF	16V E1
C116	08T52448F13	08T52448F13	08T52448F13	0.0010	Pp
C117	08S442F21	08S41442F21	08S41442F21	0.047uF	My
C118	Non Use	23T51235F24	23T51235F24	22uF	16V E1
C119	23T51235F03	23T51235F03	23T51235F03	1uF	50V E1
C120	23T51235F08	23T51235F08	23T51235F08	3.3uF	50V E1
C121	23T51235F08	23T51235F08	23T51235F08	3.3uF	50V E1
C122	23T51235F38	Non Use	Non Use	47uF	16V E1
	Non Use	23T51235F24	23T51235F24	22uF	16V E1
C123	23T51235F44	23T51235F44	23T51235F44	100uF	16V E1
C124	08T52448F13	08T52448F13	08T52448F13	1000pF	Pp (A, S)
	08T52448F17	Non Use	Non Use	1500pF	Pp (UP)
C125	23T51235F24	23T51235F24	23T51235F24	22uF	16V E1
C126	08T52448F19	Non Use	Non Use	0.0018	Pp
	Non Use	08T52448F13	08T52448F13	0.0010	Pp
C127	23T51235F16	23T51235F16	23T51235F16	10uF	16V E1
C128	08T52448F13	08T52448F13	08T52448F13	1000pF	Pp (A, S)
	08T52448F17	Non Use	Non Use	1500pF	Pp (UP)
C129	08T52448F07	Non Use	Non Use	560pF	Pp (A, S)
C130	08T52448F07	Non Use	Non Use	560pF	Pp (A, S)
C131	23T51235F08	23T51235F08	23T51235F08	3.3uF	50V E1
C132	23T51235F08	23T51235F08	23T51235F08	3.3uF	50V E1
C133	08S44505P63	08S44505P63	08S44505P63	22000pF	Ce
C134	08S44505P63	08S44505P63	08S44505P63	22000pF	Ce
C135	08S44505P63	08S44505P63	08S44505P63	22000pF	Ce
C136	23T51235F11	23T51235F11	23T51235F11	4.7uF	25V E1
C137	23S40657F52	23S40657F52	23S40657F52	220uF	16V E1
C138	08S44505P63	08S44505P63	08S44505P63	22000pF	Ce
C139	08S44505P63	08S44505P63	08S44505P63	22000pF	Ce
D140	23S40657F52	23S40657F52	23S40657F52	220uF	16V E1
C141	23T51235F16	23T51235F16	23T51235F16	10uF	16V E1
C142	23T51235F16	23T51235F16	23T51235F16	10uF	16V E1
C143	23T51235F16	23T51235F16	23T51235F16	10uF	16V E1
C144	08S44505P63	08S44505P63	08S44505P63	22000pF	Ce
C145	08S44505P49	08S44505P49	08S44505P49	1000pF	Ce
C146	08S44505P63	08S44505P63	08S44505P63	22000pF	Ce
C147	08S44505P49	08S44505P49	08S44505P49	1000pF	Ce
C148	23T51235F01	23T51235F01	23T51235F01	0.47uF	50V E1
C149	23T51235F03	23T51235F03	23T51235F03	1uF	50V E1
C150	23T51235F16	23T51235F16	23T51235F16	10uF	16V E1
C160	Non Use	23T51235F38	23T51235F38	47uF	16V E1
C161	Non Use	23T51235F08	Non Use	3.3uF	50V E1
	Non Use	23T51234F09	23T51234F09	4.7uF	25V E1
C201	Non Use	08T42081U09	Non Use	220pF	Pe

T-230/T-230L

Symble No.	T-230 Stock No.	T-230L Stock No.	T-400 Stock No.	Description
C202	Non Use	08T42081U03	Non Use	120pF Pe
C203	08T52448F01	08T52448F01	08T52448F01	0.00033 Pp
C204	21S40655F11	21S40655F11	21S40655F11	10pF Ce
C205	Non Use	21S40655F19	Non Use	47pF Ce
C206	08S44505P61	08S44505P61	08S44505P61	10000pF Ce
C207	Non Use	23T51235F31	Non Use	33uF 16V E1
C208	Non Use	23T51235F16	23T5123F16	10uF 16V E1
	Non Use	23T51235F44	Non Use	100uF 16V E1
C209				
-214	08S44505P63	08S44505P63	08S44505P63	22000pF Ce
C215	23T51235F16	23T51235F16	23T51235F16	10uF 16V E1
C216	08S44505P63	08S44505P63	08S44505P63	22000pF Ce
C217	08S44505P61	08S44505P61	08S44505P61	10000pF Ce
C218	08S44505P63	08S44505P63	08S44505P63	22000pF Ce
C219	23T51235F03	23T51235F03	23T51235F03	1uF 50V E1 (A, S)
	23T51235F11	Non Use	Non Use	4.7uF 50V E1 (U, P)
C220	23T51235F08	23T51235F08	23T51235F08	3.3uF 50V E1
C221	23T52135F01	23T52135F01	23T52135F01	0.47uF 50V E1
C222	08S44505P63	08S44505P63	08S44505P63	22000pF Ce
C223	08S44505P63	08S44505P63	08S44505P63	22000pF Ce
C224	23T51235F44	23T51235F44	23T51235F44	100uF 16V E1
C225	08S44505P49	08S44505P49	08S44505P49	1000pF Ce
C226	08S44505P53	08S44505P53	08S44505P53	2200pF Ce
C227	08S44505P53	08S44505P53	08S44505P53	2200 P F Ce
C228	08S44505P63	08S44505P63	08S44505P63	22000pF Ce
C229	23T51235F16	23T51235F16	23T51235F16	10uF 16V E1
C230	23T51235F05	23T51235F05	23T51235F05	2.2uF 50V E1
C231	23T51235F16	Non Use	Non Use	10uF 16V E1
C232	23T51235F11	23T51235F11	23T51235F11	4.7uF 25V E1
C233	23T51235F38	23T51235F38	23T51235F38	47uF 16V E1
C234	23T51235F03	23T51235F03	23T5123F03	1uF 50V E1
C235	08S44505P63	08S44505P63	08S44505P63	22000pF Ce
C236	Non Use	08S44505P63	Non Use	22000pF Ce
(Transistor & IC)				
Q101	48S44580J03	48S44580J03	48S44580J03	2SC1675
Q102	51T51095F01	51T51095F01	51T51095F01	LA1235
Q103	48S43525F02	48S43525F02	48S43525F02	2SC1815Y
Q104	48S43525F02	48S43525F02	48S43525F02	2SC1815Y
Q105	48S43525F02	48S43525F02	48S43525F02	2SC1815Y
Q106	48S43525F02	48S43525F02	48S43525F02	2SC1815Y
Q107	51T56889F01	51T56889F01	51T56889F01	HA12016
Q108	48T51878F01	48T51878F01	48T51878F01	2SC2878 A,B
Q109	48T51878F01	48T51878F01	48T51878F01	2SC2878 A,B
Q110	48T51118F01	48T51118F01	48T51118F01	2SA1015Y
Q111	48S43525F02	48S43525F02	48S43525F02	2SC1815Y
Q112	48T51118F01	48T51118F01	48T51118F01	2SA1015Y
Q113	48S44580J03	48S44580J03	48S44580J03	2SC1675
Q114	48S43525F02	48S43525F02	48S43525F02	2SC1815Y
Q201	51T53323F01	51T53323F01	51T53323F01	LA1245
Q202	48T51118F01	48T51118F01	48T51118F01	2SA1015Y
Q203	48S43525F02	48S43525F02	48S43525F02	2SC1815Y
Q204	48S43525F02	48S43525F02	48S43525F02	2SC1815Y
Q205	48S43525F02	48S43525F02	48S43525F02	2SC1815Y
Q206	Non Use	48T51118F01	Non Use	2SA1015Y
Q207	Non Use	48S43525F02	Non Use	2SC1815Y

# Synthesizer PCB Parts List

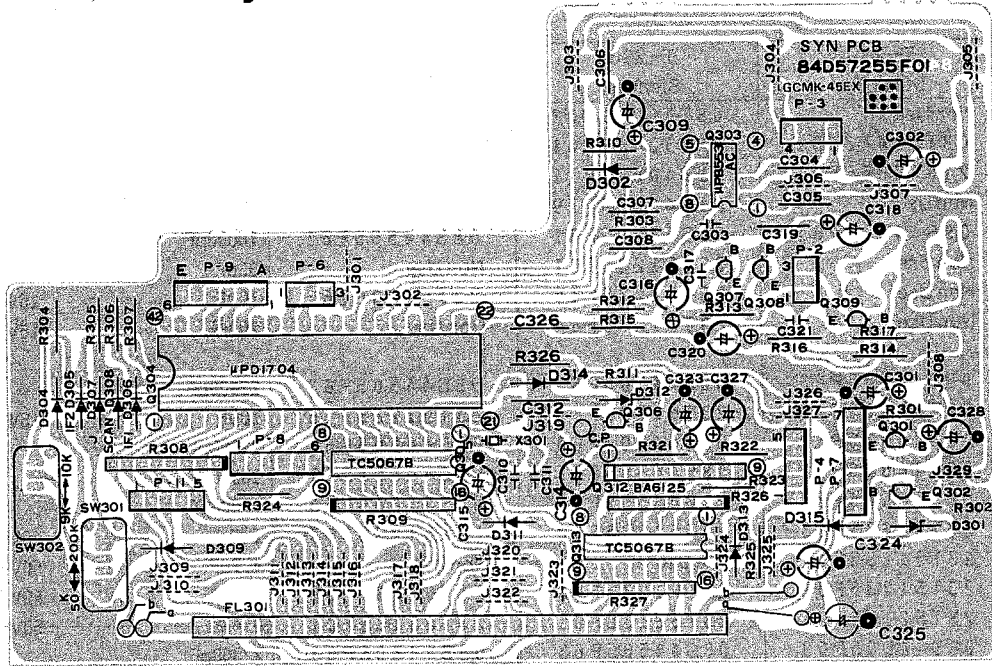

Symble No.	T-230 Stock No.	T-230L Stock No.	T-400 Stock No.	Description
(FL Meter)				
FL301	65T53335F01	65T53335F01	65T53335F01	FIP8BM4
(Crystal)				
X301	48T55072F01	48T55072F01	48T55072F01	(4.5MHz)-M
(Switch, Slide)				
SW301	40T51963F01	Non Use	Non Use	SW343-1, (FM-SW) (A, S)
SW302	40T51963F01	NonUUuse	Non Use	SW343-1, (AM-SW) (A, S)
(Diode)				
D301	48T52739F36	48T52739F36	48T52739F36	Zener, HZ6A-3
D302	48T51582F01	48T51582F01	48T51582F01	MA-150
D303	Non Use	48T51582F01	Non Use	MA-150
D304	48T51582F01	48T51582F01	Non Use	MA-150 (A, S)
D305	48T51582F01	48T51582F01	48T51582F01	MA-150
D306	48T51582F01	48T51582F01	48T51582F01	MA-150
D307	Non Use	Non Use	48T51582F01	MA-150
D309	48T51582F01	Non Use	Non Use	MA-150
D311	48T51582F01	48T51582F01	48T51582F01	MA-150
D312	48T52739F35	48T52739F35	48T52739F35	Zener, HZ6A-2
D313	48T51582F01	48T51582F01	48T51582F01	MA-150
D314	48T51582F01	48T51582F01	48T51582F01	MA-150
D315	48T51582F01	48T51582F01	48T51582F01	MA-150
(Transistor & IC)				
Q301	48T55874F01	Non Use	Non Use	2SC2060 R, Q
	48T55181F01	48T55181F01	48T55181F01	2SC1740 R, S
Q302	48T43015U01	Non Use	Non Use	2SC2120-Y
	Non Use	48T55874F01	48T55874F01	2SC2060 R, Q
Q303	51T43271F01	51T43271F01	51T43271F01	IC, UPB553AC
Q304	51T52357F01	51T52357F01	51T52357F01	IC, UPB1704C-534
Q305	51T53316F01	51T53316F01	51T53316F01	IC, TC5067BP
Q306	48T55181F01	48T55181F01	48T55181F01	2SC1740 R, S
Q307	48T55181F01	48T55181F01	48T55181F01	2SC1740 R, S
Q308	48T55181F01	48T55181F01	48T55181F01	2SC1740 R, S
Q309	48T55181F01	48T55181F01	Non Use	2SC1740 R, S
	Non Use	48T55348F01	48T55348F01	2SC1645B
Q310	Non Use	48T51118F01	Non Use	2SA1015Y
Q311	Non Use	48T55181F01	Non Use	2SC1740
Q312	51T51086F01	51T51086F01	51T51086F01	IC BA6125
Q313	51T53316F01	51T53316F01	51T53316F01	IC TC5067BP

# Synthesizer PCB Parts List

Symble No.	T-230 Stock No.	T-230L Stock No.	T-400 Stock No.	Description	
<b>(Capacitor)</b>					
C301	23T51235F38	23T51235F38	23T51235F38	47uF	16V E1
C302	23T51235F16	23T51235F16	23T51235F16	10uF	16V E1
C303	21S40655F11	21S40655F11	21S40655F11	10pF	Ce
C304	08S44505P63	08S44505P63	08S44505P63	22000pF	Ce
C305	08S44505P63	08S44505P63	08S44505P63	22000pF	Ce
C306	08S44505P63	08S44505P63	08S44505P63	22000pF	Ce
C307	08S44505P41	08S44505P41	08S44505P41	220pF	Ce
C308	08S44505P63	08S44505P63	08S44505P63	22000pF	Ce
C309	23T51235F21	Non Use	Non Use	10uF	100V E1 (A, S)
	23T51235F24	23T51235F24	23T51235F24	22uF	16V E1
C310	21S40655F15	21S40655F15	21S40655F15	22pF	Ce
C311	21S40655F15	21S40655F15	21S40655F15	22pF	Ce
C312	08S44505P63	08S44505P63	08S44505P63	22000pF	Ce
C313	23T51234F68	23T51234F68	23T51234F68	470uF	10V E1
C314	23T51235F16	Non Use	Non Use	10uF	16V E1
C315	23T51235F21	Non Use	Non Use	10uF	100V E1 (A, S)
	23T51235F24	23T51235F24	23T51235F24	22uF	16V E1
C316	23T51235F13	23T51235F13	23T51235F13	4.7uF	50V E1
C317	08S40805F21	08S40805F21	08S40805F21	22000pF	Ce
C318	23T51235F01	23T51235F01	23T51235F01	0.47uF	50V E1
C319	08S44505P63	08S44505P63	08S44505P63	22000pF	Ce
C320	23T51235F13	23T51235F13	23T51235F13	4.7uF	50V E1
C321	08S40805F21	08S40805F21	08S40805F21	22000pF	Ce
C322	Non Use	23T51235F05	Non Use	2.2uF	50V E1
C323	23T51235F03	23T51235F03	23T51235F03	1uF	50V E1
C324	23T51235F47	23T51235F47	23T51235F47	220uF	10V E1
C325	23T51235F38	23T51235F38	23T51235F38	47uF	16V E1
C326	08S40805F07	Non Use	Non Use	1000pF	Ce
	Non Use	08S44505P49	08S44505P49	1000pF	Ce
C327	23T51235F03	23T51235F03	23T51235F03	1uF	50V E1
C328	23T51235F38	23T51235F38	23T51235F38	47uF	16V E1
<b>(Resistor)</b>					
R301	06S44593P89	06S44593P89	06S44593P89	10K	1/4W Rd
R302	06S44593P73	06S44593P73	06S44593P73	2.2K	1/4W Rd
R303	06S44594P22	06S44594P22	06S44594P22	220K	1/4W Rd
R304	06S44594P14	06S44594P14	06S44594P14	100K	1/4W Rd
R305	06S44594P14	06S44594P14	06S44594P14	100K	1/4W Rd
R306	06S44594P14	06S44594P14	06S44594P14	100K	1/4W Rd
R307	06S44594P14	06S44594P14	06S44594P14	100K	1/4W Rd
R308	51T51133F01	51T51133F01	51T51133F01	Network, Res.	
R309	51T51133F01	51T51133F01	51T51133F01	Network, Res.	
R310	06S44594P06	06S44594P06	06S44594P06	47K	1/4W Rd
R311	06S44593P73	06S44593P73	06S44593P73	2.2K	1/4W Rd
R312	06S44593P65	06S44593P65	06S44593P65	1K	1/4W Rd
R313	06S44593P59	06S44593P59	06S44593P59	560	1/4W Rd
R314	06S44593P81	06S44593P81	06S44593P81	4.7K	1/4W Rd
R315	06S44593P65	06S44593P65	06S44593P65	1K	1/4W Rd
R316	06S44593P73	06S44593P73	06S44593P73	2.2K	1/4W Rd
R317	06S44593P89	06S44593P89	06S44593P89	10K	1/4W Rd
R318	Non Use	06S44593P97	Non Use	22K	1/4W Rd
R319	Non Use	06S44593P97	Non Use	22K	1/4W Rd
R320	Non Use	06S44594P06	Non Use	47K	1/4W Rd
R321	06S44594P06	06S44594P06	06S44594P06	47K	1/4W Rd
R322	06S44593P89	06S44593P89	06S44593P89	10K	1/4W Rd
R323	06S44593P89	06S44593P89	06S44593P89	10K	1/4W Rd
R324	06S44594P06	06S44594P06	06S44594P06	47K	1/4W Rd
R325	06S44594P06	06S44594P06	06S44594P06	47K	1/4W Rd
R326	06S44593P89	06S44593P89	06S44593P89	10K	1/4W Rd
	51T51133F01	51T51133F01	51T51133F01	Network, Res.	
R327	51T51133F01	51T51133F01	51T51133F01	Network, Res.	

T-230/T-230L

# Ass'y Power Trans PCB Parts List

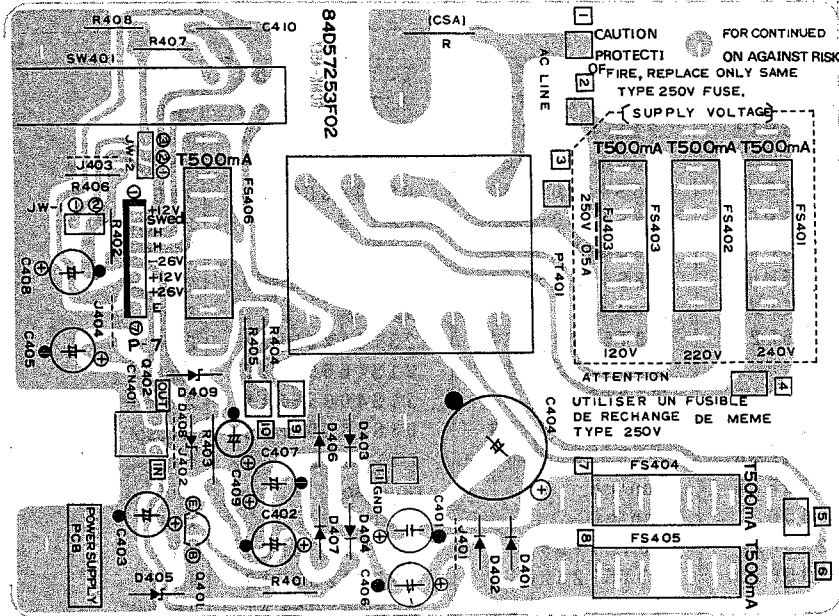

Symble No.	T-230 Stock No.	T-230L Stock No.	T-400 Stock No.	Description
<b>(Trans, Power)</b>				
PT401	25T57254F01 25T57254F04	25T57254F01 Non Use	25T57254F02 Non Use	Trans, Power (A, S) Trans, Power (UP)
<b>(Switch)</b>				
SW401	40T57645F01	40T57645F01	40T57645F01	SW, Push SUF (Short)
<b>(Fuse)</b>				
F402	65T42077U13	65T42077U13	Non Use	Fuse, Semko T-500mA (A, S)
F403	65T52486F01	Non Use	65T55050F05	Fuse, 0.5A (UP)
F404	65T42077U08	65T42077U08	Non Use	Fuse, Semko T-160mA (A, S)
F405	65T42077U08	65T42077U08	Non Use	Fuse, Semko T-160mA (A, S)
F406	65T42077U13 65T52486F01	65T42077U13 Non Use	Non Use 65T55050F05	Fuse, Semko T-500mA (A, S) Fuse, 0.5A (UP)
<b>(Holder, Fuse)</b>				
F402	09T51410F01	09T51410F01	Non Use	Holder, Fuse (A, S)
F403	09T51960F01	Non Use	09T51960F01	Holder, Fuse (UP)
F404	09T51410F01	09T51410F01	Non Use	Holder, Fuse (A, S)
F405	09T51410F01	09T51410F01	Non Use	Holder, Fuse (A, S)
F406	09T51410F01 09T51960F01	09T51410F01 Non Use	Non Use 09T51960F01	Holder, Fuse (A, S) Holder, Fuse (UP)
<b>(Semi Conductor)</b>				
Q401	48S43525F02	48S43525F02	48S43525F02	TR 2SC1815Y
Q402	51T56583F07	51T56583F07	51T56583F07	IC, Voltage L78V 12V
<b>(Diode)</b>				
D401	48T55186F01	48T55186F01	48T55186F01	SI GP10D
D402	48T55186F01	48T55186F01	48T55186F01	SI GP10D
D403	48T55186F01	48T55186F01	48T55186F01	SI GP10D
D404	48T55186F01	48T55186F01	48T55186F01	SI GP10D
D405	48T52739F94	48T52739F94	48T52739F94	Zener, HZ27-1
D406	48T55186F01	48T55186F01	48T55186F01	SI GP10D
D407	48T55186F01	48T55186F01	48T55186F01	SI GP10D
D408	48T52739F92	48T52739F92	48T52739F92	Zener, HZ24-2
D409	48T52739F36	48T52739F36	48T52739F36	Zener, HZ6A-3



Symble No.	T-230 Stock No.	T-230L Stock No.	T-400 Stock No.	Description	
<b>(Capacitor)</b>					
C401	23T51235F41	23T51235F41	23T51235F41	47uF	50V E1
C402	Non Use	23T51234F41	23T51234F41	47uF	63V E1
C403	23T51235F39	23T51235F39	23T51235F39	47uF	25V E1
C404	23T51234F79	23T51234F79	23T51234F79	1000uF	35V E1
C405	23S40657F52	23S40657F52	23S40657F52	220uF	16V E1
C406	23T51235F41	23T51235F41	23T51235F41	47uF	50V E1
C407	Non Use	23T51234F41	23T51234F41	47uF	63V E1
C408	23T51235F03	23T51235F03	23T51235F03	1uF	50V E1
C409	23T51235F39	23T51235F39	23T51235F39	47uF	25V E1
C410	08S44505P63	08S44505P63	08S44505P63	22000pF	Ce
<b>(Resistor)</b>					
R401	06S44593P89	06S44593P89	06S44593P89	10K	1/4W Rd
R402	06S44594P10	06S44594P10	06S44594P10	68K	1/4W Rd
R403	06D40801G73	06D40801G73	06D40801G73	2.7K	1/2W Rd
R404	06S44593P49	06S44593P49	06S44593P49	220	1/4W Rd
R405	06S44593P49	06S44593P49	06S44593P49	220	1/4W Rd
R406	06S44593P99	06S44593P99	06S44593P99	27K	1/4W Rd

## Memory PCB Parts List

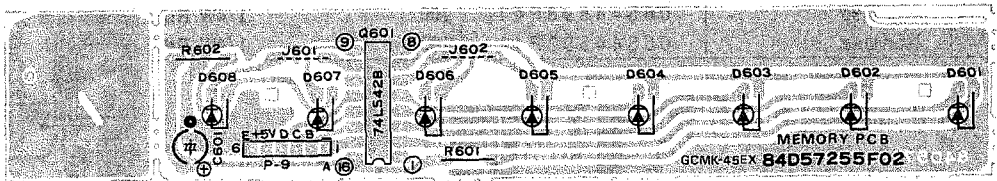

Symble No.	T-230 Stock No.	T-230L Stock No.	T-400 Stock No.	Description	
<b>(Diode)</b>					
D601	48T57256F01	48T57256F01	48T57256F01	LED, SLC26URS	
D602	48T57256F01	48T57256F01	48T57256F01	LED, SLC26URS	
D603	48T57256F01	48T57256F01	48T57256F01	LED, SLC26URS	
D604	48T57256F01	48T57256F01	48T57256F01	LED, SLC26URS	
D605	48T57256F01	48T57256F01	48T57256F01	LED, SLC26URS	
D606	48T57256F01	48T57256F01	48T57256F01	LED, SLC26URS	
D607	48T57256F01	48T57256F01	48T57256F01	LED, SLC26URS	
D608	48T57256F01	48T57256F01	48T57256F01	LED, SLC26URS	
<b>(Resistor)</b>					
R601	06S44593P57	06S44593P57	06S44593P57	470	1/4W Rd
R602	06S44593P57	06S44593P57	06S44593P57	470	1/4W Rd
<b>(Transistor)</b>					
Q601	51T53321F01	51T53321F01	51T53321F01	IC, M74LS42P	
<b>(Capacitor)</b>					
C601	23T51235F16	23T51235F16	23T51235F16	10uF	16V E1

# Store PCB Parts List

Symble No.	T-230 Stock No.	T-230L Stock No.	T-400 Stock No.	Description
<b>(Switch)</b>				
SW501				
-SW510	40T51081F01	40T51081F01	40T51081F01	SW, TACT
SW511	40T57065F01	40T57064F01	40T57065F01	SW, PUSH SUL-4KEY
<b>(Variable, Resistor)</b>				
VR501	18C42061J14	Non Use	18C42061J14	10K-B
<b>(Diode)</b>				
D501				
-D510	48T51881F01	48T51881F01	48T51881F01	DS442-BT
<b>(Transistor)</b>				
Q501	48S43525F02	Non Use	48S43525F02	2SC1815Y
<b>(Capacitor)</b>				
C501	08S44505P63	08S44505P63	08S44505P63	22000pF Ce
C503	23T51235F16	Non Use	23T51235F16	10uF 16V E1
C504	08S40656F17	Non Use	08S40656F17	0.022uF My
C505	08S40656F17	Non Use	08S40656F17	0.022uF My
C506	08S40656F17	Non Use	08S40656F17	0.022uF My
C507	23T51235F16	Non Use	23T51235F16	10uF 16V E1
C508	Non Use	23T51234F15	Non Use	10UF 25V E1
	Non Use	Non Use	23T51235F16	10uF 16V E1
C509	23T51235F03	Non Use	23T51235F03	1uF 50V E1
<b>(Resistor)</b>				
R501	06S44593P81	Non Use	06S44593P81	4.7K 1/4W Rd
R502	06S44593P81	Non Use	06S44593P81	4.7K 1/4W Rd
R503	06S44593P91	Non Use	06S44593P91	12K 1/4W Rd
R504	06S44594P12	Non Use	06S44594P12	82K 1/4W Rd
R505	06S44593P65	Non Use	06S44593P65	1K 1/4W Rd
R506	06S44593P81	Non Use	06S44593P81	4.7K 1/4W Rd
R507	06S44593P69	Non Use	06S44593P69	1.5K 1/4W Rd
R508	06S44593P41	Non Use	06S44593P41	100 1/4W Rd
R509	06S44593P41	Non Use	06S44593P41	100 1/4W Rd

# UP&DOWN PCB Parts List

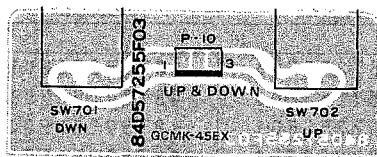

Symble No.	T-230 Stock No.	T-230L Stock No.	T-400 Stock No.	Description
<b>(Switch)</b>				
SW701	40T51081F01	40T51081F01	40T51081F01	SW, TACT
SW702	40T51081F01	40T51081F01	40T51081F01	SW, TACT

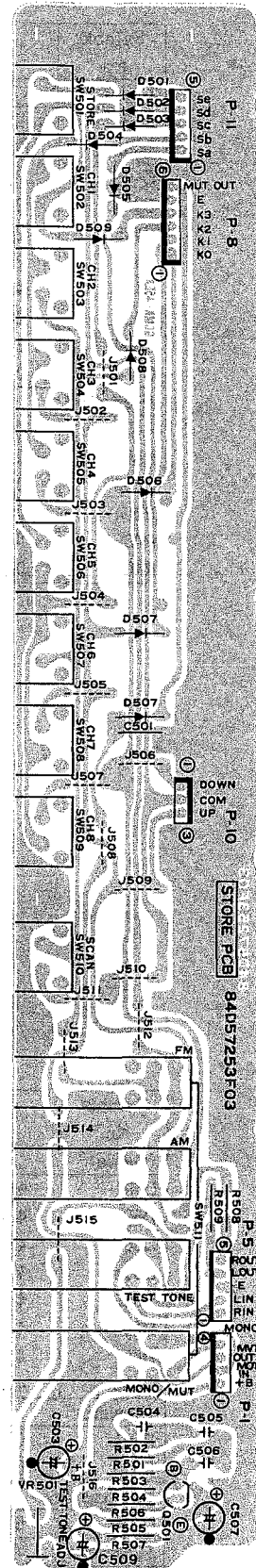

## Destinations' Parts List (T-230)

Symbol No.	Description	Power Source		
		AL (220V) Europe	AK (220V) Europe	UQ (120V) Canada
13-2	Trans,Power	25T57254F01	25T57254F01	25T57254F04
F402,406	Fuse	65T42077U13 (T-500mA)	65T42077U13 (T-500mA)	Non Use
F403		Non Use	Non Use	65T52486F31 (0.5A)
F404,405		65T42077U08 (T-160mA)	65T42077U08 (T-160mA)	Non Use
F402,404 F405,406	Holder,Fuse	09T51410F01	09T51410F01	Non Use
F403		Non Use	Non Use	09T51960F01
7	Cover,Rear.	15C56858F03	15C56858F03	15C56858F04
10	Conector ANT.	09T51080F01	09T51080F01	Non Use
8	Plug,Cord	28T43812P04	28T43812P04	28T55335F01
C124,128	Capacitor (75u sec/50u sec)	08T52448F13 (1000pF)	08T52448F13 (1000pF)	08T52448F17 (1500pF)

\*T-230L AK(220)-Type Only, for Europe

\*T-400 J(100V)-Type Only, for Japan

### Remarks

**Capacitor;** EL.....Electrolytic, Capacitor  
 Ce.....Ceramic, Capacitor  
 My.....Mylar, Capacitor  
 Mi.....Mica, Capacitor  
 Pe.....Polyethelen, Capacitor  
 Po.....Polystyrene, Capacitor  
 Pp.....Polypropylene, Capacitor  
 LR.....Low Leak, Capacitor  
 BP.....Bi-Polar, Capacitor

**Resistor;** Rd.....Carbon, Resistor  
 Rm....Metal Film, Resistor  
 Rc.....Cement, Resistor

T-230/T-230L

# IC Handling Guide

LA-1235 (MONOLITHIC LINEAR IC)

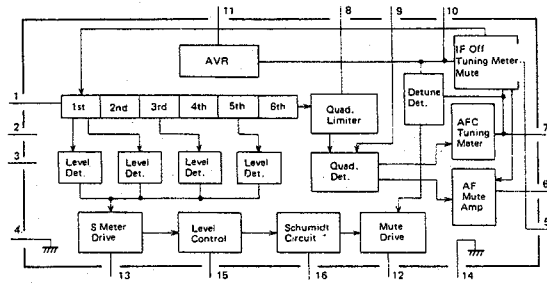

HA-12016 (FM STEREO MULTIPLEX DECODER)

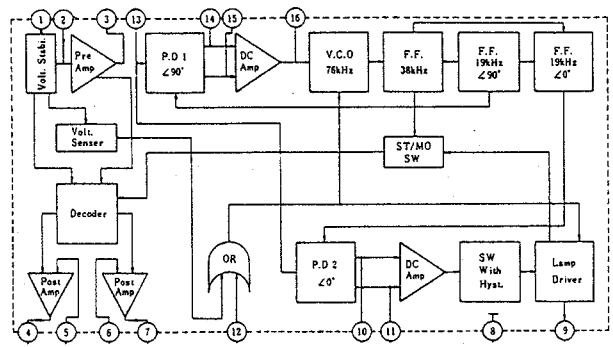

BA-6125 (LED LINEAR LEVEL METER DRIVE)

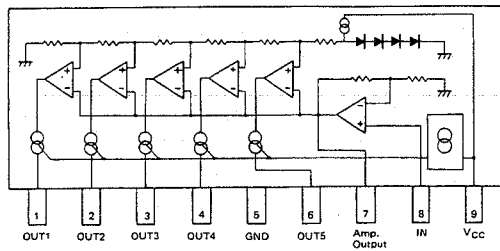

μPC1704 (SYNTHESIZER IC)

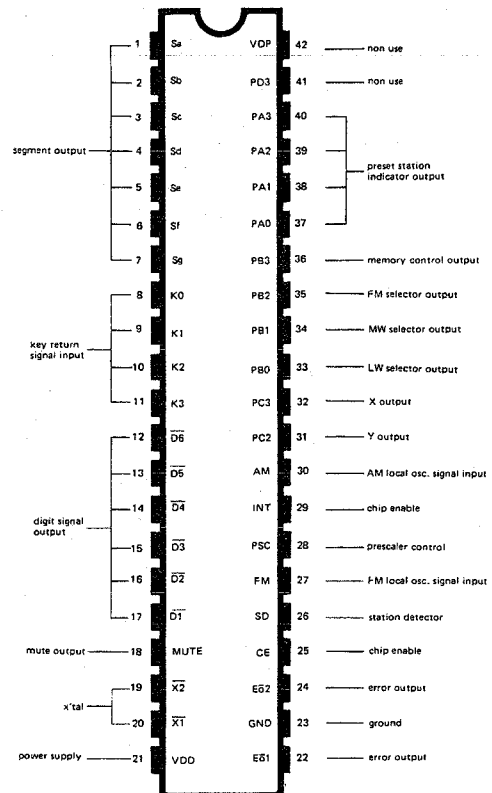

LA-1245 (AM IC)

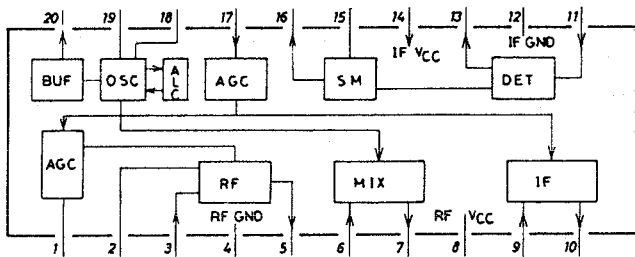

μPB553AC (150MHz PRESCALER)

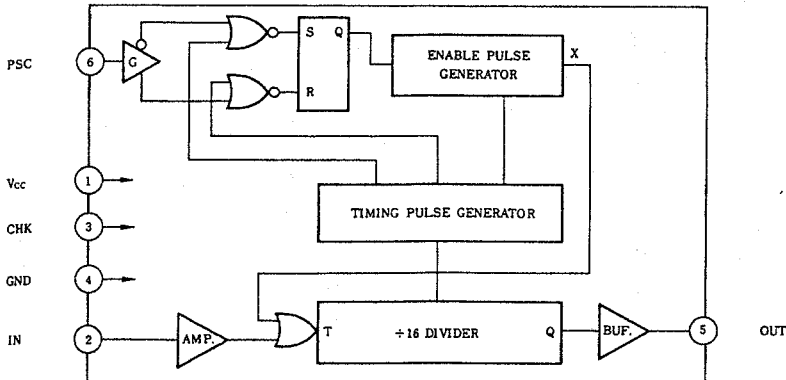

T-230/T-230L

# Schematic Diagram(A)

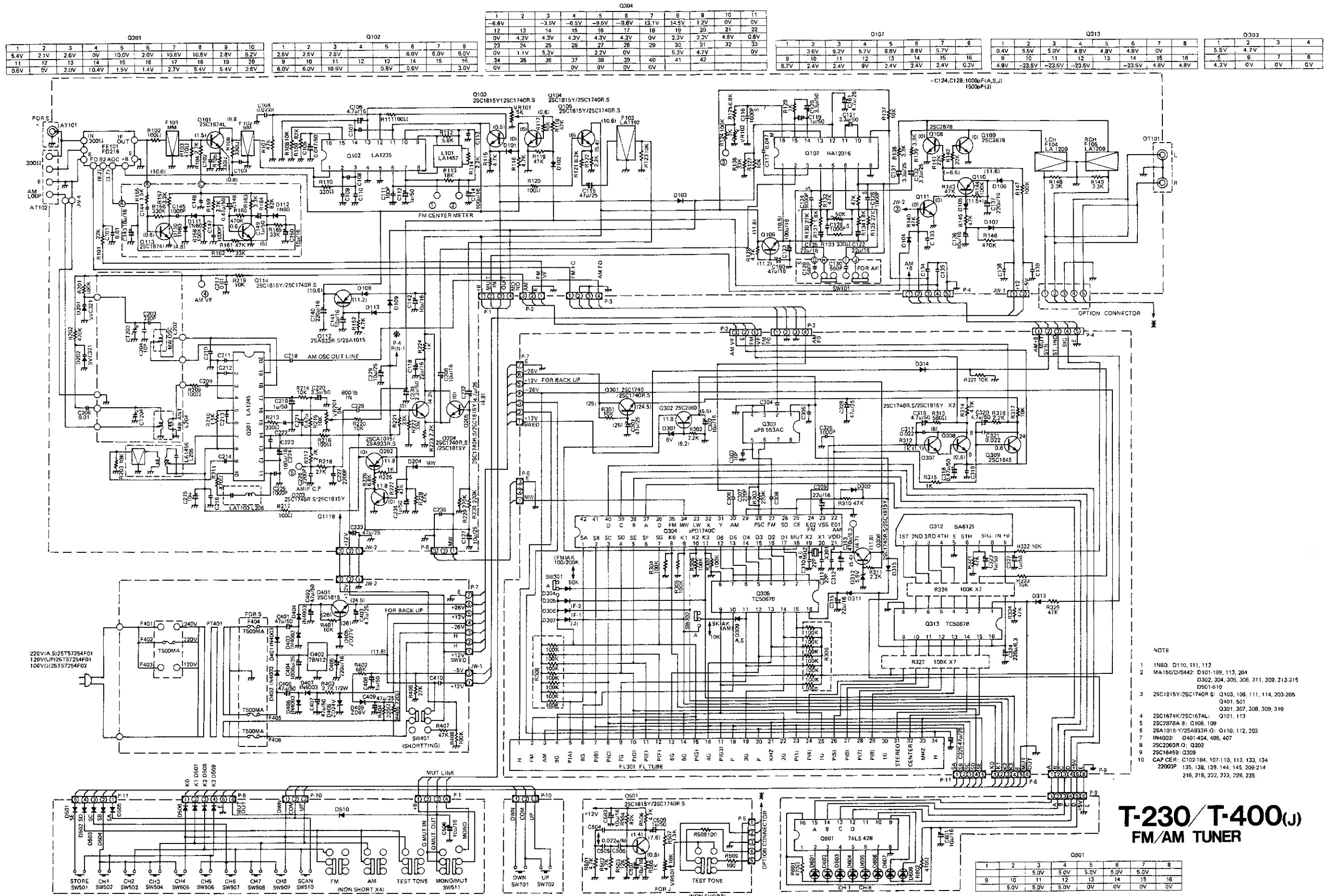

**T-230/T-400(J)**  
FM/AM TUNER

# Schematic Diagram(B)

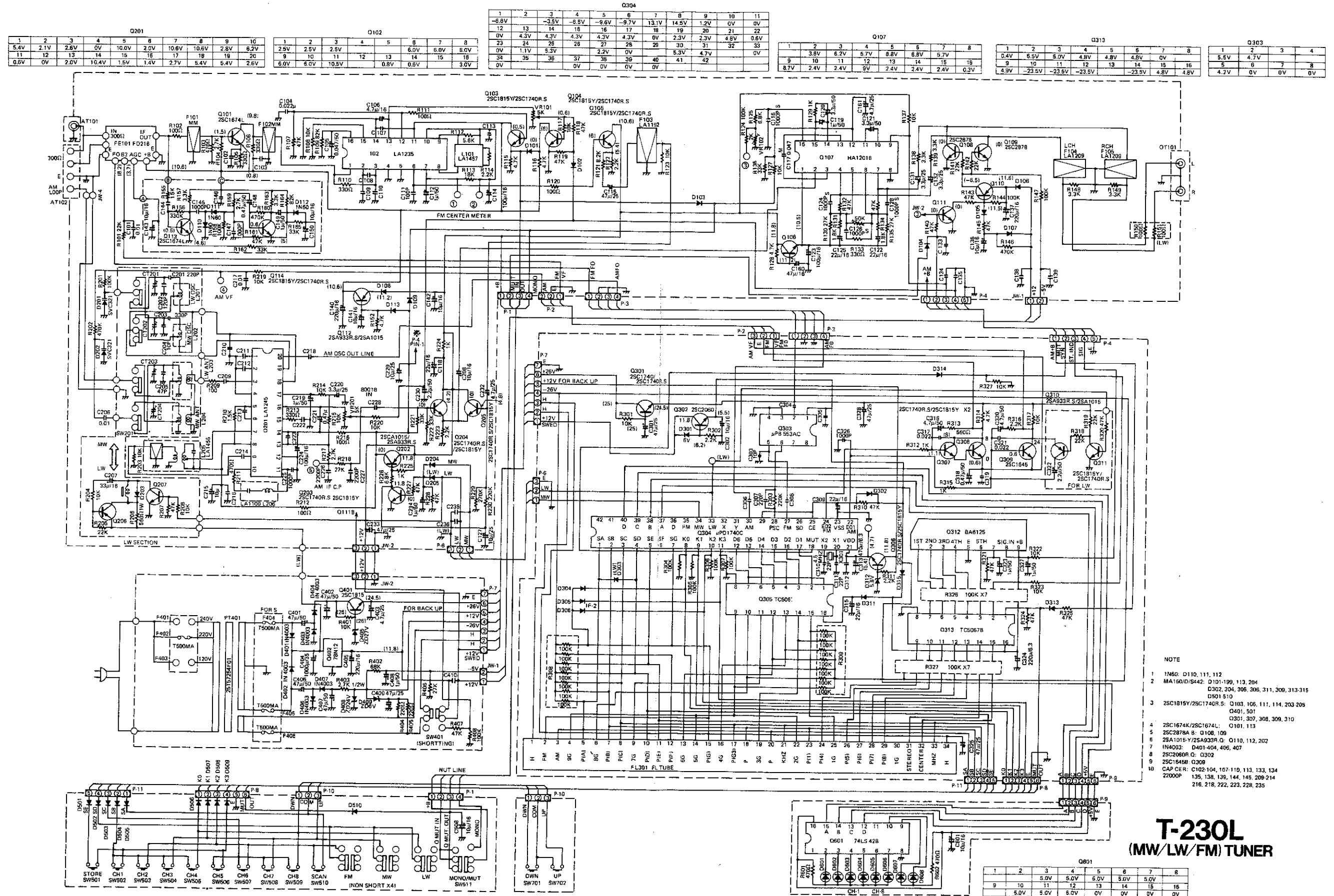

1	2	3	4	5	6	7	8	9	10
5.4V	2.1V	2.6V	0V	10.0V	2.0V	10.6V	10.6V	2.8V	6.2V
11	12	13	14	15	16	17	18	19	20
0.8V	0V	2.0V	10.4V	1.5V	1.4V	2.7V	5.4V	5.4V	2.6V

1	2	3	4	5	6	7	8
2.5V	2.5V	2.5V		6.0V	6.0V	6.0V	
9	10	11	12	13	14	15	16
6.0V	6.0V	10.5V		0.8V	0.6V		3.0V

1	2	3	4	5	6	7	8	9	10	11
-8.8V		-3.5V	-6.5V	-8.6V	-9.7V	13.1V	14.5V	1.2V	0V	0V
12	13	14	15	16	17	18	19	20	21	22
0V	4.3V	4.3V	4.3V	4.3V	4.3V	0V	2.3V	2.3V	4.8V	0.6V
23	24	25	26	27	28	29	30	31	32	33
0V	1.1V	5.3V		2.2V	0V		6.3V	4.7V		0V
34	35	36	37	38	39	40	41	42		
0V	0V	0V	0V	0V	0V	0V	0V	0V		

1	2	3	4	5	6	7	8
	3.8V	6.2V		5.7V	8.8V	8.8V	5.7V
9	10	11	12	13	14	15	16
8.7V	2.4V	2.4V	9V	2.4V	2.4V	2.4V	0.3V

1	2	3	4	5	6	7	8
0.4V	6.5V	6.0V	4.8V	4.8V	4.8V	0V	0V
9	10	11	12	13	14	15	16
4.3V	-23.5V	-23.5V	-23.5V	-23.5V	4.8V	4.8V	

1	2	3	4
5.5V	4.7V		
5	6	7	8
4.2V	0V	0V	0V

- NOTE
- 1 IN6G: D110, 111, 112
  - 2 MA150/D/S42: D101-199, 113, 204  
D302, 304, 305, 306, 311, 309, 313-315  
D501-510
  - 3 2SC1815Y/2SC1740R-S: Q103, 105, 111, 114, 203, 205  
Q401, 501  
Q301, 307, 308, 309, 310
  - 4 2SC1674K/2SC1674L: Q101, 113
  - 5 2SC2878A-B: Q108, 109
  - 6 2SA1015-Y/2SA933R-Q: Q110, 112, 202
  - 7 IN4003: D401-404, 406, 407
  - 8 2SC2969R-Q: Q302
  - 9 2SC1545B: Q309
  - 10 CAP CER: C102-104, 107-110, 113, 133, 134  
2200P 135, 138, 139, 144, 145, 209-214  
216, 218, 222, 223, 228, 235

## T-230L (MW/LW/FM) TUNER

1	2	3	4	5	6	7	8
		5.0V	5.0V	5.0V	5.0V	5.0V	
9	10	11	12	13	14	15	16
	5.0V	5.0V	5.0V	0V	0V	0V	0V

SPECIFICATIONS

<b>&lt; FM Section &gt;</b>	
Usable Sensitivity :	75 ohms/300 ohms
50 dB Quieting Sensitivity :	75 ohms/300 ohms
S/N Ratio at 65 dBf :	75 ohms/300 ohms
Frequency Response :	20 Hz - 15 kHz (±0.5 dB)
Distortion at 65 dBf :	1.75 μV/3.5 μV (16.0 dBf)
	77 dB/75 dB
	20 Hz - 15 kHz (±0.5 dB)
mono/stereo	100Hz
	0.1%
	0.1%
mono	1kHz
	0.2%
	0.1%
stereo	100Hz
	0.15%
	0.3%
	1.5 dB
Capture Ratio at 65 dBf :	
Alternate Channel Selectivity :	75kHz deviation
	40kHz deviation
	Spurious Response Ratio :
	100 dB
	100 dB
	IF Response Ratio :
	Image Response Ratio :
	AM Suppression Ratio :
	Stereo Separation :
	100Hz
	45dB
	50dB
	1kHz
	10kHz
	5 μV
Muting Threshold :	
Output Level :	100% MOD, 700 mV
<b>&lt; AM Section &gt;</b>	
Usable Sensitivity :	53 dB/m
Image Response Ratio :	45 dB
IF Response Ratio :	50 dB
Distortion :	0.3%
S/N Ratio :	50 dB
Output Level :	250 mV
<b>&lt; General &gt;</b>	
Power Consumption :	7W
Dimensions :	453 (W) × 229 (D) × 77 (H) mm
Net	3.0 kgs (6.6 lbs.)
Gross	4.0 kgs (8.8 lbs.)

Specifications and appearance design subject to change without notice.

規格

<b>〈FMセクション〉</b>	
1H F 実用感度	75Ω/300Ω
S/N 50dB 感度	1.75μV/3.5μV (16dBf)
MONO	75Ω/300Ω
STEREO	75Ω/300Ω
比 MONO/STEREO	80dB/76dB
周波数特性	20～15,000Hz (±0.5dB以内)
歪	100Hz
(WIDE)	1kHz
歪	6kHz
STEREO	100Hz
	0.08%
	0.15%
	0.08%
	1kHz
	0.08%
	6kHz
	0.08%
	100Hz
	80dB
	70dB (±400kHz)
	55dB (±300kHz)
	100dB
	100dB
	AM 抑圧比
	キヤッチャ比
	ステレオ・セパレーション
	100Hz
	45dB
	50dB
	1kHz
	30dB
	700mV
<b>〈AMセクション〉</b>	
1H F 実用感度	53dB/m
歪率	0.3%
S/N 比	50dB
1×10 <sup>-5</sup> 妨害比	45dB
出力電圧	250mV
<b>〈その他〉</b>	
電源電圧	100V (50Hz/60Hz)
消費電力	7W
外形寸法	453(幅)×229(奥行)×77(高)mm
重量	3.0kg
	正味

★規格および外観は改良のため予告なしに変更することがあります。