

SERVICE MANUAL

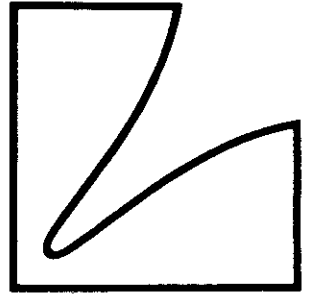

DIGITAL FREQUENCY SYNTHESIZED AM FM STEREO TUNER **T-115**

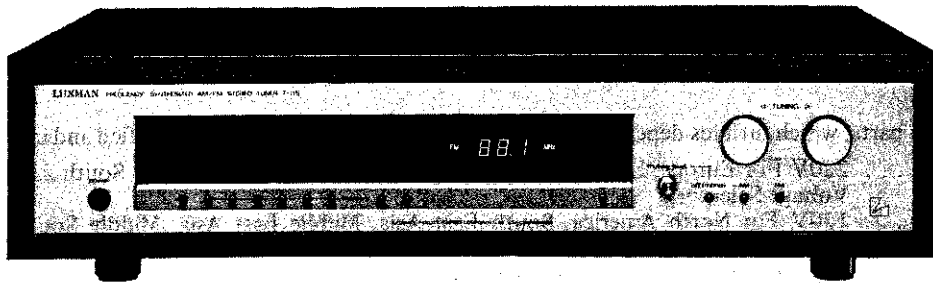

CONTENTS

- BLOCK DIAGRAM 1
- ALIGNMENT PROCEDURE 2 · 3 · 4
- REPLACEMENT PARTS LIST 5
- EXPLODED VIEW 6
- Exploded view parts list 7
- PCB PARTS LIST 9 · 10 · 11 · 12
- T-115 SCHEMATIC DIAGRAM 13
- STANDARD CURVES 14
- SPECIFICATIONS 15

NOTE

In this manual the parts, which differes depending on destination and mains voltage, are classified and indicated as follow.

- E —
 - EK 220V For Europe, South Asia, East Asia, Middle East Asia, Middle South America (With Line Voltage Selector).
 - EZ 120V For North America, South East Asia, Middle East Asia, Middle South America (With Line Voltage Selector).
- S —
 - SK 220V For Europe, South East Asia, South America.
 - SG 240V For England, Oceania.
 - SB 240V For Australia.
- U —
 - U 120V For North America.
 - UW 120V For Canada.
- J 100V For Japan.

BLOCK DIAGRAM

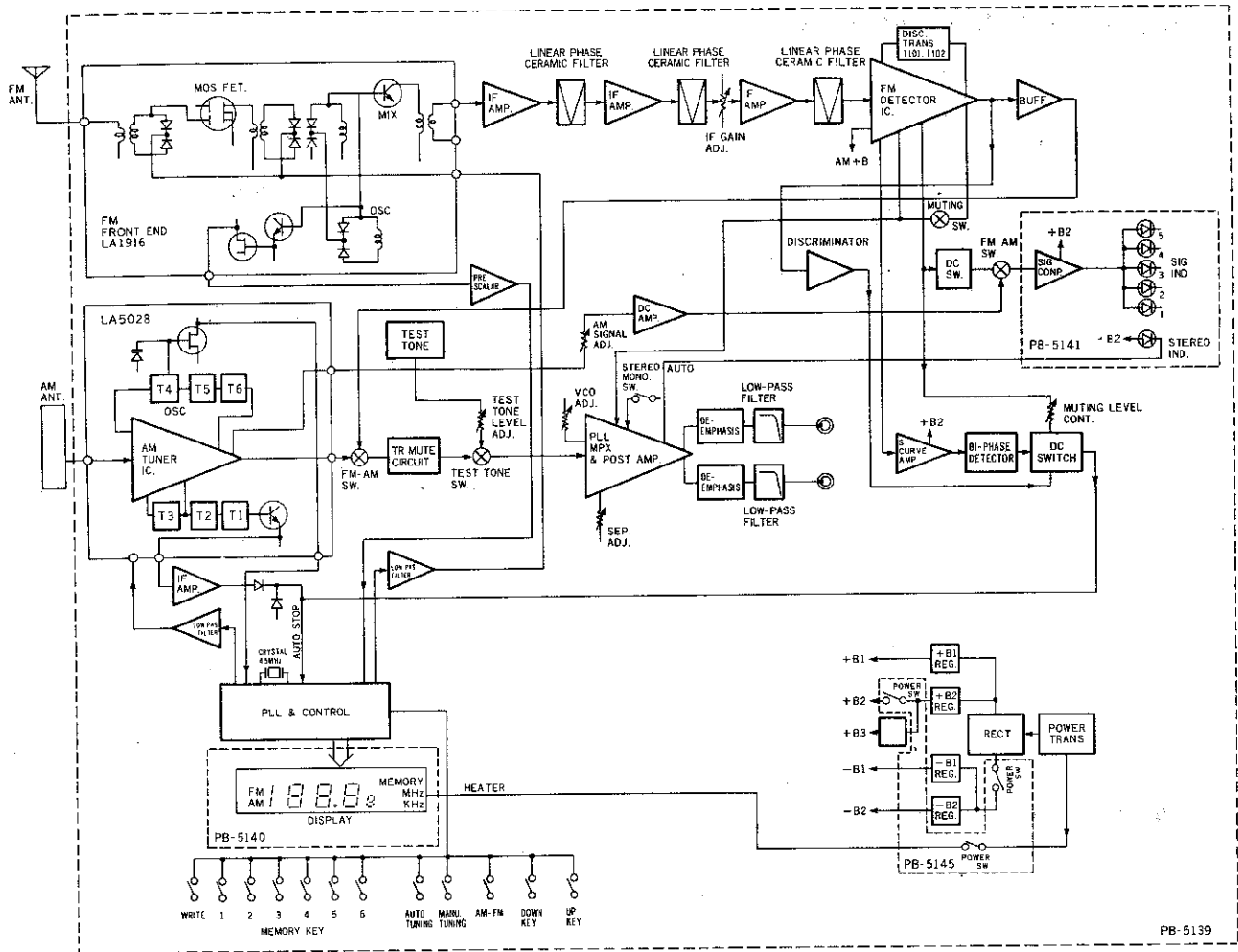

[μPB 5330]

BLOCK DIAGRAM

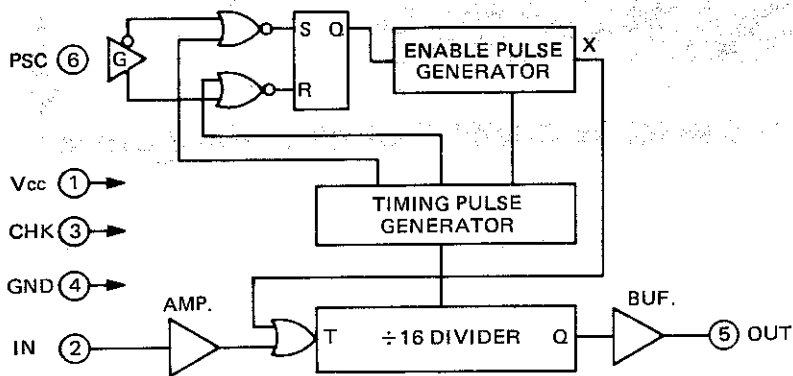

PIN CONNECTION

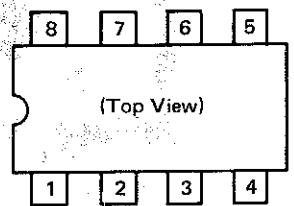

Pin No.	
1	Vcc
2	IN
3	CHK
4	GND
5	OUT
6	PSC
7	NC
8	NC

TIMING CHART

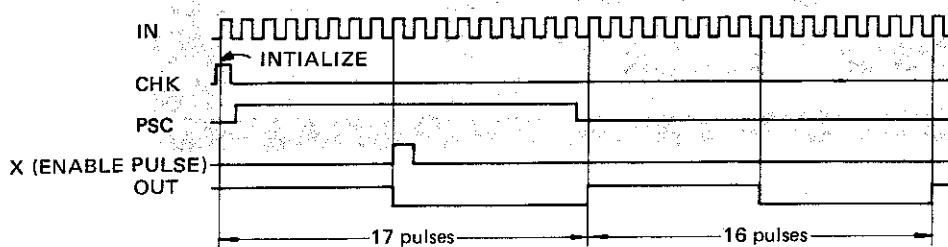

ALIGNMENT PROCEDURE

Adjustment Point on PCB

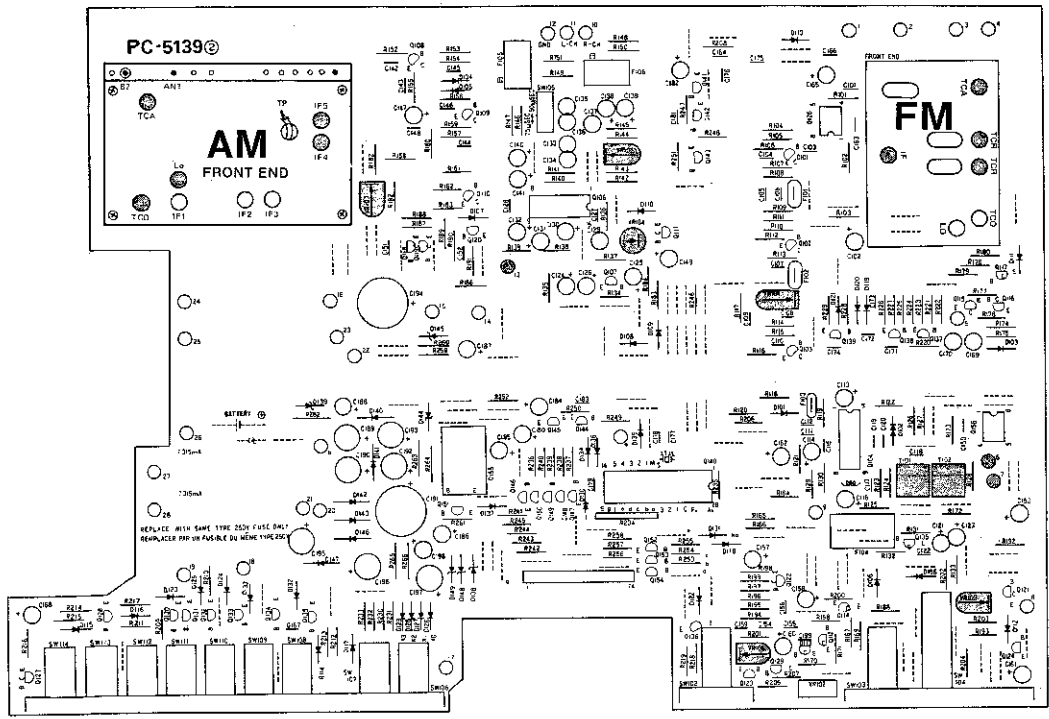

Switches & Terminal

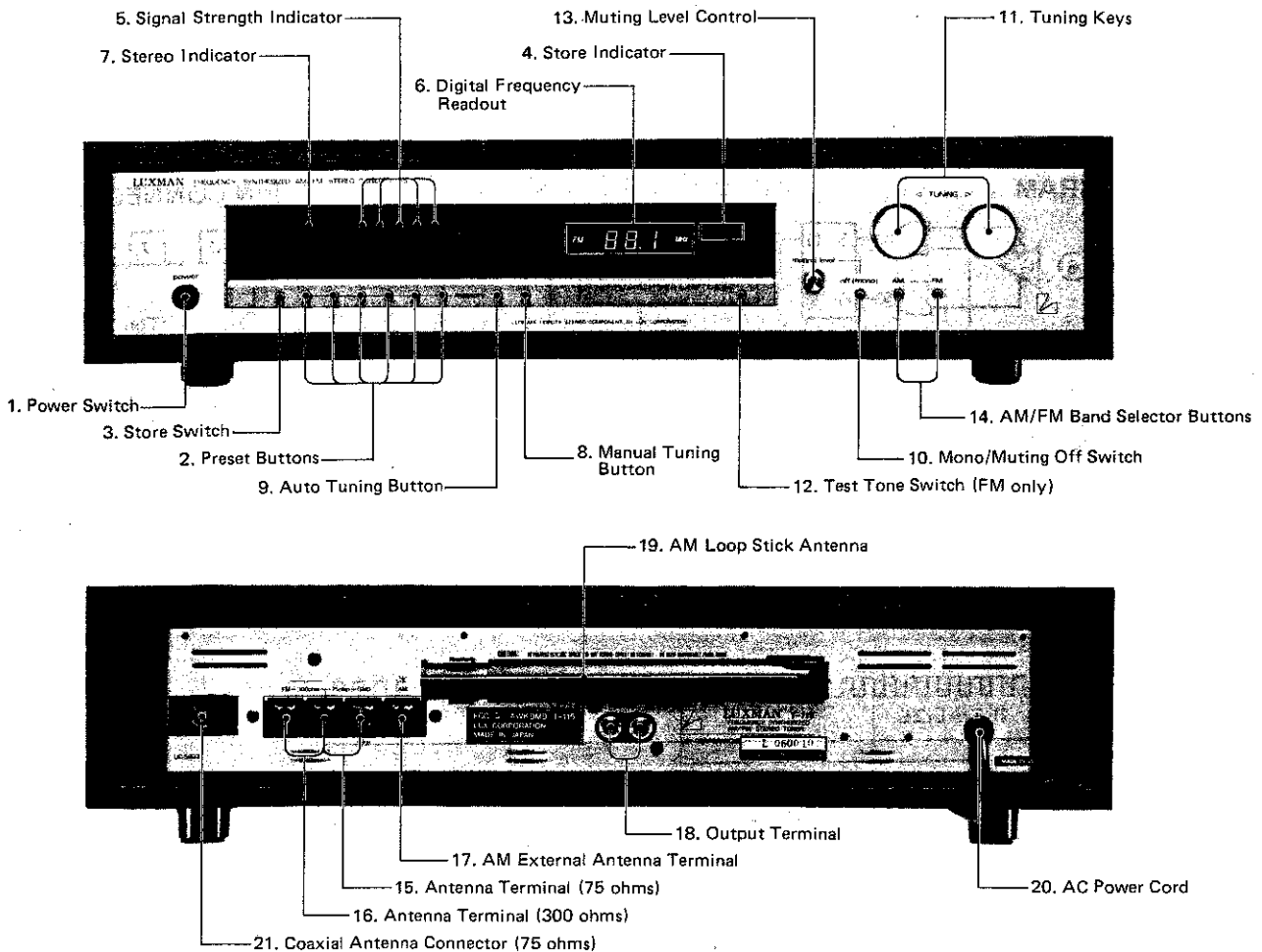

1) Test equipment required and connection method.

Oscilloscope
 AC Voltmeter
 Distortion Analyzer
 FM Signal Generator FM-SG --- Connect to the Antenna terminal through matching network. (Balun)
 MPX Generator ----- Connect to the FM-SG
 Galvanometer ($\pm 100 \mu\text{A}$)
 Frequency Counter

Connect all the testing equipments as per Fig. 1:

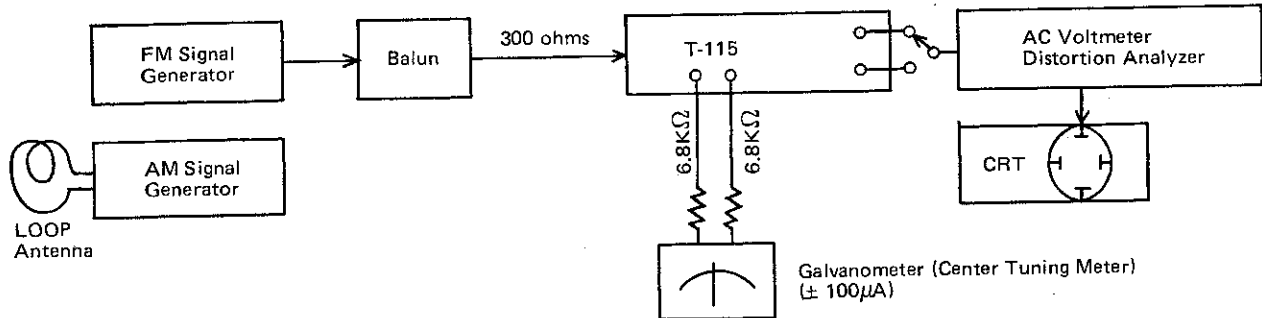

Fig. 1

FM SECTION

2) Pre-Setting of VR's

- VR101: Turn clockwise to the maximum for IF gain adjustment.
- VR103: Turn counter-clockwise to the maximum for signal strength level.
- VR104: Turn to the center position for MPX VCO adjustment.
- VR105: Turn to the center position for MPX separation adjustment.

3) Setting of Front Panel Function

- Muting Theshold VR: Turn counter-clockwise to the maximum
- Manual Tuning Switch: ON (manual)
- AM/FM Function Switch: FM
- Muting Switch: OFF
- Test Tone Switch: OFF

4) FM Discriminator, Distortion Adjustment

- 1) Set Signal Generator at 98MHz with output, 1mV Non-modulation.
- 2) Tune the T-115 at 98MHz.
- 3) Connect $\pm 100 \mu\text{A}$ Galavanometer having 6.8K ohm resistor in series to pin (6) and Pin (7) on PC5139.
- 4) Confirm the 1KHz signal coming at the output terminal of the T-115.
- 5) Adjust T101, FM Transformer to null point of above Meter.
- 6) Adjust T102, FM Transformer to make distortion minimum.
- 7) Repeat the above procedures 4 and 5 three or four times to obtain the "null" point of Center Tuning Meter and minimum distortion at the same time.

5) FM Tracking Adjustment

- 8) Set Signal Generator at 108MHz, output $2 \mu\text{V}$, 1KHz 100% modulation and tune the T-115 at 108 MHz.
- 9) Turn TCA, TCR the trimmers of the front-end to obtain maximum output level and sensitivity.
- 10) Adjust IF coil of the front-end to make the maximum output and sensitivity

6) FM Muting and Signal Strength Adjustment

- 11) Set Signal Generator at 98MHz, 1KHz 100% modulation and tune T115 at 98MHz.
- 12) Push Muting Sw. at "ON" and set output of Signal Generator to $5 \mu\text{V}$ and adjust VR101 to appear the signal of 1KHz at the tuner output.
- 13) Adjust VR103 to make 5th L.E.D. of signal strength indicator light at $300 \mu\text{V}$ output of Signal Generator.
- 14) Make output of Signal Generator null and confirm L.E.D. unlit.

7) MPX Adjustment

- 15) Connect frequency counter between check pin 13 and ground.
- 16) Set Signal Generator at 98MHz non-modulation, output 1mV and adjust VR104 to get VCO frequency 19KHz^{+0}_{-10} Hz on frequency counter reading.
- 17) Make left or right stereo modulation at 1KHz 90%, pilot signal 10%, with Signal Generator and adjust VR105 to make separation maximum and balanced on left and right channels.

8) Test Tone Level Adjustment

- 18) Set Signal Generator at 98MHz, output 1mV, 400Hz 100% modulation and tune the T115 at 98MHz.
- 19) Note output level of the T115 at output terminal.
- 20) Push tone switch "ON" and adjust VR106 to make -6dB level against output level noted step 19.

AM SECTION**9) AM PLL Adjustment**

- 21) Connect DC Voltmeter to terminal B 2 of AM front-end and ground.
- 22) Tune the T115 at 1404KHz/E,S, 1400KHz/U and Adjust TCO to obtain $15.5\text{V} \pm 0.05\text{V}$ reading on meter.
- 23) Tune the T115 at 603KHz/E,S, 600KHz/U and adjust L0 to obtain $2.5\text{V} \pm 0.05\text{V}$ reading on meter.
- 24) Repeat step 22 and 23 so as to get accurate PLL adjustment.

10) AM IF Adjustment

- 25) Connect the output of 450KHz Sweep Generator to the ANT 1 terminal.
- 26) Connect the input of Sweep Generator to TP terminal and set the output of Sweep Generator to 40-50dB.
- 27) Adjust IF1-IF3 so as to obtain maximum symmetrical single peak response.

11) AM Tracking Adjustment

- 28) Set Signal Generator at 1404KHz/E,S, 1400KHz/U, 400Hz 30% modulation, field strength approx. 1404KHz/E,S, 1400KHz/U.
- 29) Adjust TCA to get maximum tuner output.
- 30) Change Signal Generator frequency and receiving frequency on tuner both at 603KHz/ES, 600KHz/U.
- 31) Adjust the bar antenna to obtain maximum tuner output.
- 32) Repeat steps 28-31 as necessary to obtain maximum sensitivity on band.
- 33) Set Signal Generator at 1008KHz/Es, 1000KHz/U, 400Hz 30% modulation, field strength 80dB/m and tune the T115 at 1008KHz/ES, 1000KHz/U.
- 34) Adjust VR107 to make 5th L.E.D. of signal strength indicator light.

12) AM Auto-Scanning IF peak adjustment

- 35) Connect Oscilloscope to IF Out terminal of AM front-end.
- 36) Set Signal Generator at 1008KHz/ES, 1000KHz/U, 400Hz 30% modulation, output level 20-40dB and tune the T115 at 1008KHz/ES, 1000KHz/U.
- 37) Adjust IF 4 and IF5 to obtain maximum level on Oscilloscope.
- 38) Confirmation
 - a) L.E.D.'s of Signal Strength Indicator not to light at no signal input and to light in order from 1st to 5th according to input signal of T-115.
 - b) Muting level to vary from 10 to $300\mu\text{V}$ with muting threshold VR.
 - c) Stereo indication L.E.D. to light upon stereo reception.
 - d) Pre-set tuning on right function and memory store as well.
 - e) Memory frequency not to change or store, by ON-OFF operation of Power Sw.
 - f) To scan between 87.50MHz and 108.00MHz under auto-tuning at no signal input.
 - g) To automatically stop under auto-tuning when the signal in the procedure 16 is given.
 - h) To start scanning when Tuning Button is continuously pressed for a few seconds and to stop when Tuning Button is released under manual-tuning.
 - i) Tuning frequency to increase or decrease by every 50KHz at FM and 9KHz at AM on one push of UP-DOWN key under manual tuning.
 - j) Receiving frequency not to be less than 87.50MHz and more than 108.00MHz.

REPLACEMENT PARTS LIST

Packing Material

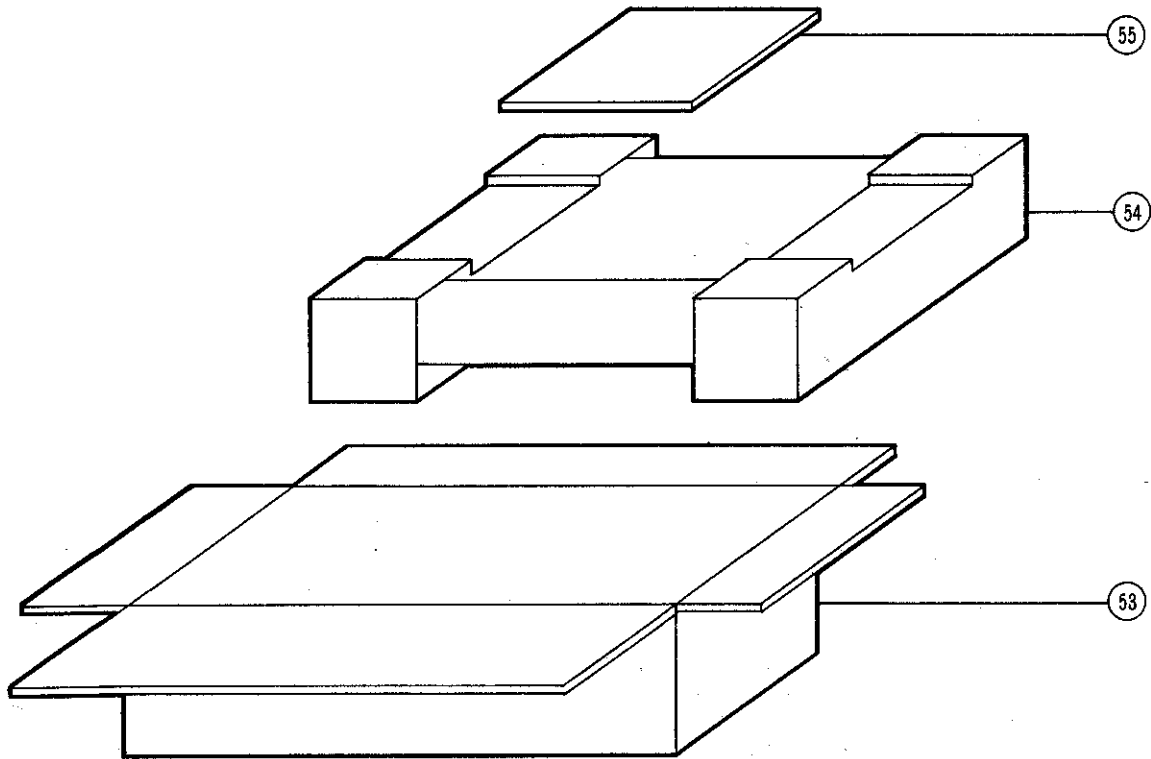

EXPLODED VIEW

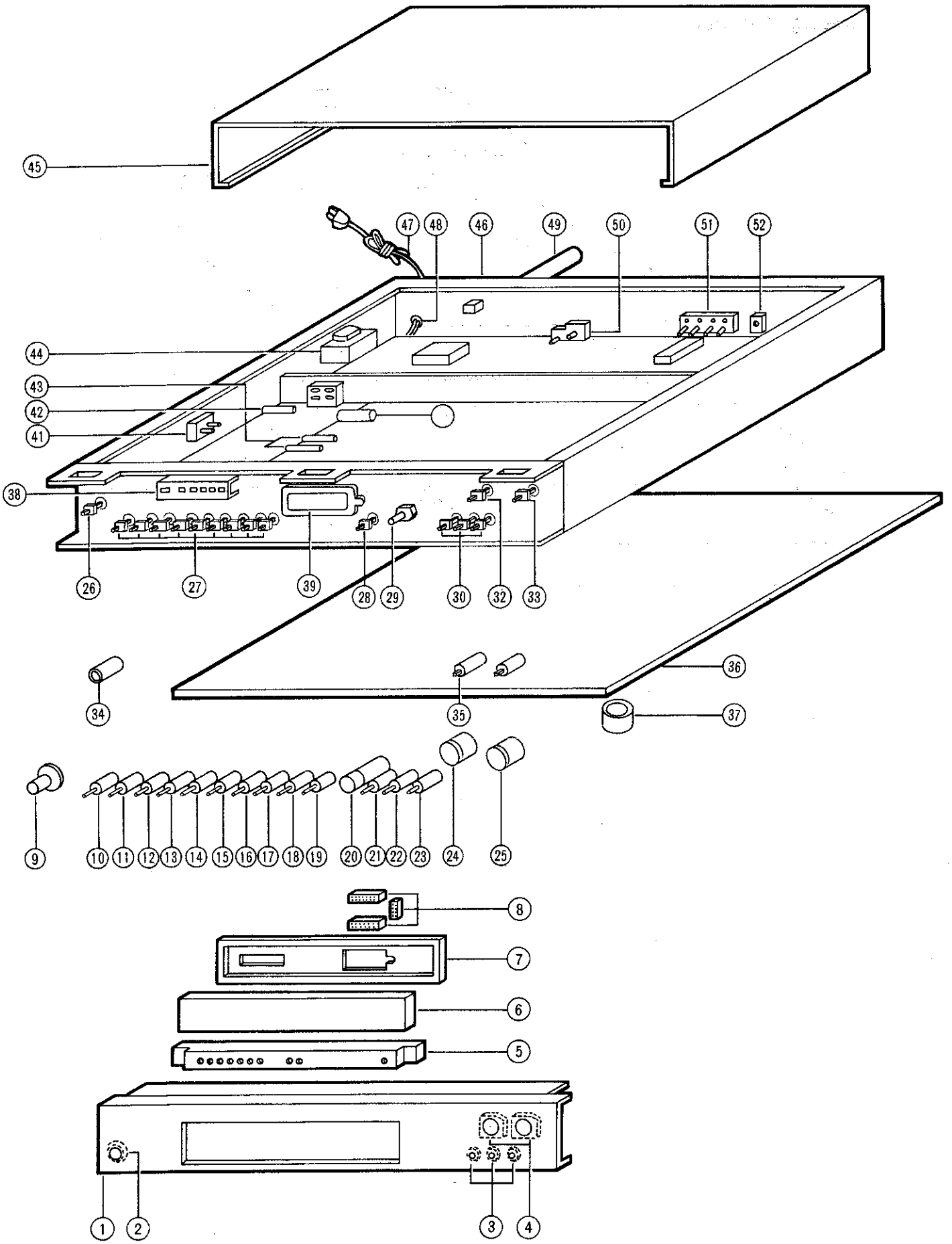

Exploded view parts list

SYMBOL NO.	STOCK NO.	DESCRIPTION
[Front Panel Ass'y Parts List]		
1	WA5064	Front Panel
2	WE1089	Protector -Power-
3	WE1086	Protector -Muting Off, AM, FM-
4	WE1056	Protector -Tuning-
5	WD5020	Escutcheon
6	WU5008	Dial Acryl
7	UL5004	Masking Plate
8	WZ5067	Sponge
[Knob Parts List]		
9	WJ1133	Power
10	WJ1134BL	Store
11	WJ1140	Memory 1
12	WJ1140	Memory 2
13	WJ1140	Memory 3
14	WJ1140	Memory 4
15	WJ1140	Memory 5
16	WJ1140	Memory 6
17	WJ1140	Auto
18	WJ1140	Manual
19	WJ1140	Test Tone
20	WH1076	Muting Level (EK, EZ, J, SK, SG)
	WH1076B	Muting Level (U)
21	WJ1140	Muting Off
22	WJ1140	AM
23	WJ1140	FM
24	WK1123	Tuning (EK, EZ, J, SK, SG)
	WK1123B	Tuning (U)
25	WK1123	Tuning (EK, EZ, J, SK, SG)
	WK1123B	Tuning (U)
[Switch & VR Parts List]		
26	SP5051	Power SW (EK, EZ, SK, SG)
	SP0113	Power SW (U, J)
27	SP5049	Push SW -Memory, Audio, Manual-
28	SP0162	Push SW -Test Tone-
29	RV5070	VR121 50KB VR102 -Muting Level-
30	SP5062	Push SW -Muting off, AM, FM-
32	SP5050	Push SW SWH12H -Tuning -
33	SP5050	Push SW SWH12H -Tuning -
[Mechanism & Electrolytic Parts List]		
34	UZ5032	Extension Shaft
35	UZ1124	Extension Shaft

SYMBOL NO.	STOCK NO.	DESCRIPTION
36	UE1103	Bottom Plate
37	WN1019	Foot (U)
	WN0007	Foot (EK, EZ, J, SK, SG)
38	UL5005	Masking Plate
39	TT5010	Display Tube FIP708
40	TA5001	Battery 50FT-3-1 (J)
		Battery 50MA 3.6V (U)
41	AC0054	Voltage Select Socket
	AC0014	Voltage Select Plug
42	BF0071	Fuse ULCS-MF61M-0.2A (EZ, U)
	BF0108	Fuse MF60NR-0.2A (EK, J)
	BF0201	Fuse 5 x 20 0.1A (T) (SK, SG)
43	BF0113	Fuse MF60NR 1A (EK, EZ, J, SK, SG)
	BF0204	Fuse 5 x 20 0.315A (T) (SK, SG)
44	PT5102	Power Trans P-2518 (J)
	PT5103	Power Trans P-2535 (U)
	PT5104	Power Trans P-2536 (SK, SG)
	PT5105	Power Trans P-2537 (E)
45	UG1024	Bonnet
	WB1078	Wooden Case (U)
[Rear Panel Ass'y Parts List]		
46	UC5033	Rear Panel
47	BK0018	AC Cord (EZ, U)
	BK0022	AC Cord (EK, SK)
	BK0023	AC Cord (SG)
	BK0027	AC Cord (UW)
	BK0036	AC Cord (SB)
48	BU0036	Cord Stopper (SB)
	BU0033	Cord Stopper (EK, EZ, U, SK)
	BU0039	Cord Stopper (SB, SG, UW)
49	LA1132A	Bar Antenna
50	AT5017	2P Pin Jack
51	AT0121	ANT Terminal
52	AS0156	Coaxial ANT Connector
[Packing Material Parts List]		
53	XA5116B	Carton (EK, EZ, SK, SG)
	XA5116A	Carton (U)
	XA5116BJ	Carton (J)
54	XB1041	Pad (EK, EZ, J, SK, SG)
	XB1036A	Pad (U)
[Owner's Manual Parts List]		
54	ME5018	Owner's Manual (EK, EZ, SK, SG)
	ME5021	Owner's Manual (U)
	MA5066	Owner's Manual (J)

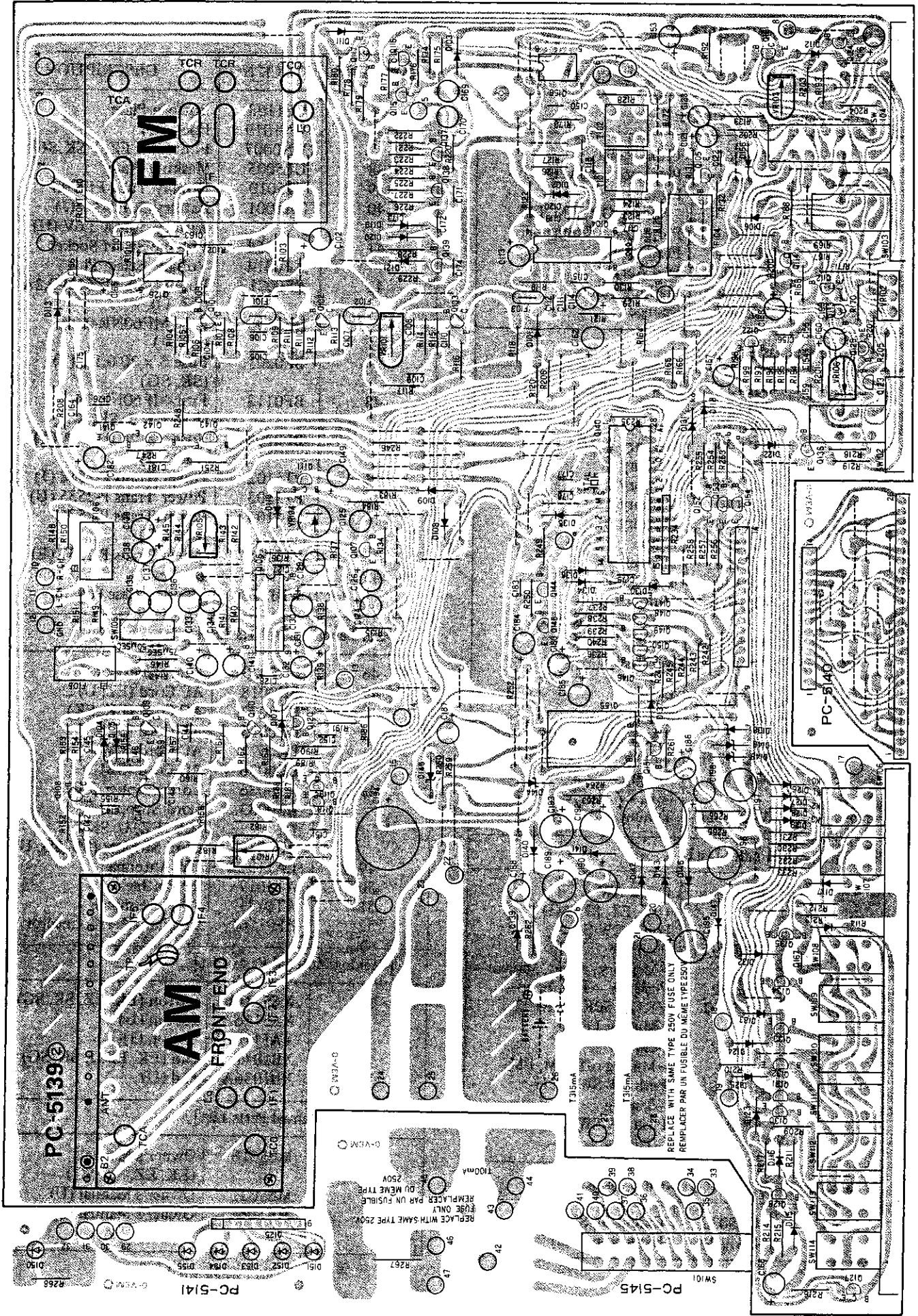

P.C.B. parts list

REMARKS

Capacitor: My Mylar, El . . Electrolytic, St . . .Styrol, Ce . . .Ceramic
 Mi Mica, Ta . . Tantalum, Lp . . .Line pass (AC Cap.)
 TmTrimmer, Ac . . .Ac Capacitor, Fi . . .Film Cap.
 Resistor: Rd Carbon, Rc . . .Cement, Rm . .Metal Film, Rf . . .Flame proof
 Ro Oxid Metal,
 ± 5%, 0.25W, unless specified otherwise.

SYMBOL NO.	STOCK NO.	DESCRIPTION	REMARK
[Capacitor]			
C101	CK0157T	0.04μF 25WV Ce	
C102	CE1721T	100μ 16 El	
C103	CK0155T	0.01μ 50 Ce	
C104	CK0157T	0.04μ 25 Ce	
C105	CK0157T	0.04μ 25 Ce	
C106	CK0155T	0.01μ 50 Ce	
C107	CC0038T	50P 50 Ce	
C108	CK0155T	0.01μ 50 Ce	
C109	CK0157T	0.04μ 25 Ce	
C111	CK0157T	0.04μ 25 Ce	
C112	CK0157T	0.04μ 25 Ce	
C113	CK1717T	10μ 16 El	
C114	CE1749T	0.47μ 50 El	
C115	CC0007T	100P 50 Ce	
C116	CE1749T	0.47μ 50 El	
C117	CK0157T	0.04μ 25 Ce	
C118	CK0157T	0.04μ 25 Ce	
C119	CK0157T	0.04μ 25 Ce	
C120	CK0157T	0.04μ 25 Ce	
C121	CE1718	0.04μ 25 Ce	
C122	CK0109	470P 50 Ce	
C123	CE1718T	22μ 16 El	
C124	CE1718T	22μ 16 El	
C125	CE1719T	33μ 16 El	
C126	CE1717T	10μ 16 El	
C127	CK0155T	0.01μ 50 Ce	
C128	CQ0009T	0.047μ 50 My	
C129	CQ5078	470P 50 St	E, S, U
C130	CE1750T	1μ 50 El	
C131	CE1752T	3.3μ 50 El	
C132	CS0019	0.22μ 35 Ta	
C133	CQ1402	1800P 50 St	
	CQ1428	1200P 50 St	
C134	CQ1402	1800P 50 St	
	CQ1428	1200P 50 St	
C135	CQ1419	620P 50 St	
C136	CQ1419	620P 50 St	
C137	CQ5078	470P 50 St	
C138	CE1717T	10μ 16 El	
C139	CE1717T	10μ 16 El	
C140	CE1751T	2.2μ 50 El	
C141	CE1751T	2.2μ 50 El	
C142	CK0157T	0.04μ 25 Ce	
C143	CK0157T	0.04μ 25 Ce	
C144	CK0157T	0.04μ 25 Ce	
C145	CK0157T	0.04μ 25 Ce	
C146	CK0157T	0.04μ 25 Ce	
C147	CE1751T	2.2μ 50 El	
C148	CK0157T	0.04μ 25 Ce	
C149	CE1750T	1μ 50 El	

SYMBOL NO.	STOCK NO.	DESCRIPTION	REMARK
C150	CK0159	0.1μF 25WV Ce	
C151	CK0155T	0.01μ 50 Ce	
C152	CK0155T	0.01μF 50WV Ce	
C153	CE1749	0.47μ 50 El	
C154	CQ0013	0.022μ 50 My	
C155	CQ0013T	0.022μ 50 My	
C156	CQ0013T	0.022μ 50 My	
C157	CE1717T	10μ 16 El	
C158	CE1717T	10μ 16 El	
C159	CQ0013T	0.022μ 50 My	
C160	CE1717T	10μ 16 El	
C161	CE1751T	2.2μ 50 El	
C162	CE1751T	2.2μ 50 El	
C163	CK0155T	0.01μ 50 Ce	
C164	CC0009T	220P 16 Ce	
C165	CE1720T	47μ 16 El	
C166	CK01571	0.04μ 25 Ce	
C167	CK0155T	0.01μ 50 Ce	
C168	CE0785	0.47μ 50 El	
C169	CQ1410	220P 50 St	
C170	CQ1410	220P 50 St	
C171	CQ0026T	0.01μ 50 My	
C172	CC0007T	100P 50 Ce	
C174	CK0157T	0.04μ 25 Ce	
C175	CK0155T	0.01μ 50 Ce	
C176	CC038T	50P 50 Ce	
C177	CC0006T	47P 50 Ce	
C178	CC0006T	47P 50 Ce	
C179	CK0157	0.04μ 25 Ce	
C180	CE1715	1000μ 10 El	
C181	CQ1337	0.22μ 50 My	
C182	CE0787	2.2μ 50 El	
C183	CQ0011T	0.033μ 50 My	
C184	CE0787	2.2μ 50 El	
C185	CE1720T	47μ 16 El	
C186	CE1721T	100μ 16 El	
C187	CE1732T	100μ 25 El	
C188	CE1742T	47μ 35 El	
C189	CE1758	100μ 50 El	
C190	CE1743	100μ 35 El	
C191	CE1736	1000μ 25 El	
C192	CE1733	220μ 25 El	
C193	CE1721T	100μ 16 El	
C194	CE1726	2200μ 16 El	
C195	CE1743	100μ 35 El	
C196	CE1758	100μ 50 El	
C197	CE1744	220μ 35 El	
C198	CE1717T	10μ 16 El	
C199	CK0157T	0.04μ 25 Ce	

SYMBOL NO.	STOCK NO.	DESCRIPTION	REMARK
[Diode]			
D101	TD0132T	1S2472	
D102	TV0030	VARISTOP KB265C4	
D103	TD0132T	1S2472	
D104	TD0018	1K188FM-1	
D105	TD0018	1K188FM-1	
D106	TD0132T	1S2472	
D107	TD0132T	1S2472	
D108	TD0132T	1S2472	
D109	TD0132T	1S2472	
D110	TD0132T	1S2472	
D111	TD0132T	1S2472 TP	
D112	TD0132T	1S2472	
D113	TD0132T	1S2472	
D115	TD0132T	1S2472	
D116	TD0132T	1S2472	
D117	TD0132T	1S2472	
D118	TD0132T	1S2472	
D119	TD0132T	1S2472	J, E, S
D120	TD0132T	1S2472	J, E, S
D121	TD0132T	1S2472	J, E, S
D122	TD0132T	1S2472	
D123	TD0132T	1S2472	
D123	TD0132T	1S2472	
D124	TD0132T	1S2472	
D125	TD0132T	1S2472	
D126	TD0197	US1070	
D127	TD0197	US1070	J, E, S
D128	TD0132T	1S2472	
D129	TD0132T	1S2472	
D130	TD0132T	1S2472	
D131	TD0132T	1S2472	
D132	TD0132T	1S2472	
D134	TD0132T	1S2472	
D135	TD0132T	1S2472	
D136	TD0132T	1S2472	
D137	TD0132T	1S2472	
D138	TD5026T	ZENER WZ-065	
D139	TD0152T	ZENER WZ-270	
or	TD0152	ZENER WZ-270	
D140	TD0002	IN4002	
D141	TD0002	IN4002	
D142	TD0002	IN4002	
D143	TD0002	IN4002	
D144	TD0079T	ZENER WZ-140	
D145	TD0178	ZENER WZ-032 3.2V	
D146	TD0002	IN4002	
D147	TD0002	IN4002	
D148	TD0143	ZENER BZ-240 24V	
D149	TD0043T	ZENER WZ-130 T8	
D151	TD0217	LED SE1123R	
D152	TD0217	LED SE1123R	
D153	TD0217	LED SE1123R	
D154	TD0217	LED SE1123R	
D155	TD0217	LED SE1123R	
D156	TD0132T	1S2472	
D213	TD0132T	1S2472	

SYMBOL NO.	STOCK NO.	DESCRIPTION	REMARK
[Filter, FM transformer]			
F101	LA1830	FM ceramic filter KMFC89M11	J
	LA1829	FM ceramic filter KMFC112M12	E, S
	LA1186	Ceramic filter, SFE10.7MLA	U
F102	LA1830	FM ceramic filter KMFC89M11	J
	LA1186	Ceramic filter SFE10.7MLA	U
	LA1829	FM ceramic filter KMFC112M12	E, S
F103	CK0155	Capacitor 0.01UF 50WV ceramic HE70	J
	LA1829	FM ceramic filter KMFC112M12	E, S
	LA1186	Ceramic filter SFE10.7MLA	U
F104	LA1192	Anti-bardi filter Lux-1192	
F105	LA1196	Low-pass filter BL-30HJ	
F106	LA1196	Low-pass filter BL-30HJ	
T101	LA5021	FM transformer	
T102	LA5022	FM transformer	
[Transistor, IC]			
Q101	TR0092	2SC1674	
Q102	TR0019	2SC1923	
Q103	TR0019	2SC1923	
Q104	TR0099	LA123INS	
Q105	TR0029	2SC945	
Q106	TC0094	IC UPC1161C	
Q107	TR0029	2SC945	
Q108	TR0029	2SC945	
Q109	TR0029	2SC945	
Q111	TR0029	2SC945	
Q112	TR0029	2SC945	
Q113	TR0029	2SC945	
Q114	TR0029	2SC945	
Q115	TR0029	2SC945	
Q116	TR0029	2SC945	
Q117	TR0043	2SA733	
Q118	TR0029	2SC945	
Q119	TR0029	2SC945	
Q120	TR0043	2SA733	
Q120	TR0029	2SC945	
Q121	TR0043	2SA733	
Q122	TR0029	2SC945	
Q123	TR0029	2SC945	
Q124	TR0029	2SC945	
Q125	TC0085	IC BA656	
Q126	TC5033	IC BA656	
Q127	TR0029	2SC945	
Q128	TR0029	2SC945	
Q129	TR0029	2SC945	
Q130	TR0029	2SC945	
Q131	TR0029	2SC945	

SYMBOL NO.	STOCK NO.	DESCRIPTION	REMARK
Q132	TR0029	2SC945	
Q133	TR0029	2SC945	
Q134	TR0029	2SC945	
Q135	TR0029	2SC945	
Q136	TR0029	2SC945	
Q137	TR0029	2SC945	
Q138	TR0029	2SC945	
Q139	TR0029	2SC945	
Q140	TC5034	IC UPD 1703C	
Q141	TR0029	2SC945	
Q142	TR0029	2SC945	
Q143	TR0029	2SC945	
Q144	TR0029	2SC945	
Q145	TR0029	2SC945	
Q146	TR0043	2SA733	
Q147	TR0043	2SA733	
Q148	TR0043	2SA733	
Q149	TR0043	2SA733	
Q150	TR0043	2SA733	
Q151	TR0029	2SC945	
Q152	TR0029	2SC945	
Q153	TR0029	2SC945	
Q154	TR0029	2SC945	
Q155	TR5012	2SD880	
Q156	TC5002	IC NJM4558D	

[Resistor]
Unless Otherwise Specified 1/4W Carbon type

R101	RB0398T	12K	
R102	RB0406T	27K	
R103	RB0332T	22	
R104	RB0364T	470	
R105	RB0390T	5.6K	
R106	RB0344T	68	
R107	RB0360T	330	
R108	RB0348T	100	
R109	RB0364T	470	
R110	RB0382T	2.7K	
R111	RB0348T	100	
R112	RB0364T	470	
R113	RB0360T	330	
R114	RB0388T	4.7K	
R115	RB0414T	56K	
R116	RB0344T	68	
R117	RB0348T	100	
R118	RB0360T	330	
R119	RB0364T	470	
R120	RB0416T	68K	
R121	RB0414T	56K	
R122	RB0396T	10K	
R123	RB0394T	8.2K	
R124	RB0356T	220	
R125	RB0406T	27K	
R126	RB0348T	100	
R127	RB0412T	47K	
R128	RB0378T	1.8K	
R129	RB0404T	22K	
R130	RB0396	10K	S, only
R131	RB0364	470	
	RB0396	10K	S, only

SYMBOL NO.	STOCK NO.	DESCRIPTION	REMARK
R132	RB0388T	4.7K	
R133	RB0388T	4.7K	
R134	RB0384T	3.3K	
R135	RB0396T	10K	
R136	RB0400T	15K	
R137	RB0400T	15K	
R138	RB0372T	1K	
R139	RB0378T	1.8K	
R140	RB0412T	47K	
R141	RB0412T	47K	
R142	RB0404T	22K	
R143	RB0404T	22K	
R144	RB0390T	5.6K	
R145	RB0390T	3.3K	
R146	RB0384T	3.3K	
R147	RB0384T	3.3K	
R148	RB0384T	3.3K	
R149	RB0384T	220	
R150	RB0356T	220	
R151	RB0356T	15K	
R152	RB0400T		
R153	RB0420T	100K	
R154	RB0380T	2.2K	
R155	RB0348T	100	
R156	RB0340T	47	
R157	RB0372T	1K	
R158	RB0332T	22	
R159	RB0412T	47K	
R160	RB0372T	1K	
R161	RB0396T	10K	
R162	RB0412T	47K	
R163	RB0404T	22K	
R164	RB0432T	330K	
R165	RB0436T	470K	
R166	RB0420T	100K	
R168	RB0416T	68K	
R169	RB0374T	1.2K	
R170	RB0396T	10K	
R171	RB0404T	22K	
R172	RB0422T	120K	
R173	RB0416T	68K	
R174	RB0388T	4.7K	
R175	RB0388T	4.7K	
R176	RB0388T	4.7K	
R177	RB0388T	4.7K	
R178	RB0404T	22K	
R179	RB0396T	10K	
R180	RB0384T	3.3K	
R182	RB0396T	10K	
R182	RB0382T	2.7K	
R183	RB0436T	470K	
R184	RB0404T	22K	
R186	RB0392T	6.8K	
R187	RB0418T	82K	
R188	RB0396T	10K	
R188	RB0388T	4.7K	
R189	RB0386T	3.9K	
R190	RB0420T	100K	
R191	RB0348T	100	
R192	RB0396T	10K	
R193	RB0388T	4.7K	

SYMBOL NO.	STOCK NO.	DESCRIPTION	REMARK
R194	RB0388T	4.7K	
R195	RB0388T	4.7K	
R196	RB0398T	12K	
R197	RB0418T	82K	
R198	RB0384T	3.3K	
R199	RB0388T	4.7K	
R200	RB0372T	1K	
R201	RB0414T	56K	
R202	RB0408	33K	S, only
	RB0380	2.2K	
R203	RB0396T	10K	
R205	RB0398T	12K	
R206	RB0428T	220K	
R207	RB0374T	1.2K	
R208	RB0428T	220K	
R209	RB0396T	10K	
R210	RB0412T	47K	
R211	RB0420T	100K	
R212	RB0396T	10K	
R213	RB0396T	10K	
R214	RB0388T	4.7K	
R215	RB0420T	100K	
R216	RB0420T	100K	
R217	RB0388T	4.7K	
R218	RB0408T	33K	
R218	RB0452T	2.2M	
R219	RB0420T	100K	
R220	RB0372T	1K	J, E, S
R221	RB0404T	22K	J, E, S
R222	RB0404T	22K	J, E, S
R223	RB0380	2.2K	J, E
R224	RB0372T	1K	J, E, S
R225	RB0396T	10K	
R226	RB0360T	330	J, E, S
R227	RB0384T	3.3K	J, E, S
R228	RB0432T	330K	J, E, S
R229	RB0384T	3.3K	J, E, S
R230	RB0408T	33K	
R231	RB0408T	33K	
R232	RB0408T	33K	
R233	RB0408T	33K	
R234	RK7001	100K x 4, Resistor Array	
R235	RB0412T	47K	
R236	RB0412T	47K	
R237	RB0412T	47K	
R238	RB0412T	47K	
R239	RB0412T	47K	
R240	RB0412T	47K	
R241	RB0420T	100K	
R242	RB0420T	100K	
R243	RB0420T	100K	
R244	RB0420T	100K	
R245	RB0420T	100K	
R246	RB0388T	4.7K	
R247	RB0374T	1.2K	
R248	RB0382T	2.7K	
R249	RB0388T	4.7K	
R250	RB0384T	3.3K	
R251	RB0396T	10K	
R252	RB0396T	10K	

SYMBOL NO.	STOCK NO.	DESCRIPTION	REMARK
R253	RB0412T	47K	
R254	RB0412T	47K	
R255	RB0412T	47K	
R256	RB0420T	100K	
R257	RB0420T	100K	
R258	RB0420T	100K	
R259	RB0332T	22	
R260	RB0332T	22	
R261	RB0372T	1K	
R262	RD2594	3.3K 1/2W	
R263	RD2574	470 1/2W	
R264	RD2574	470 1/2W	
R265	RD2586	1.5K 1/2W	
R266	RD2590	2.2K 1/2W	
R268	RB0396T	10K	
[Switch]			
SW101	SP5051	Power	
SW102	SP0162	Test tone	
SW103	SP5062	Muting off	
SW104	SP5062	AM/FM	
SW105	SS0012	De-Emphasis	
SW106	SP5049	Manual	
SW107	SP5049	Auto	
SW108	SP5049	Memory 6	
SW109	SP5049	Memory 5	
SW110	SP5049	Memory 4	
SW111	SP5049	Memory 3	
SW112	SP5049	Memory 2	
SW113	SP5049	Memory 1	
SW114	SP5049	Store	
[Potentiometer]			
VR101	RT0054	300	B
VR103	RT0052	20K	B
VR104	RT0025	4.7K	B
VR105	RT0109	500K	B
VR106	RT0086	10K	B
VR107	RT0052	20K	B

STANDARD CURVES

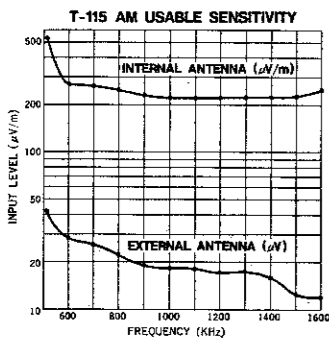
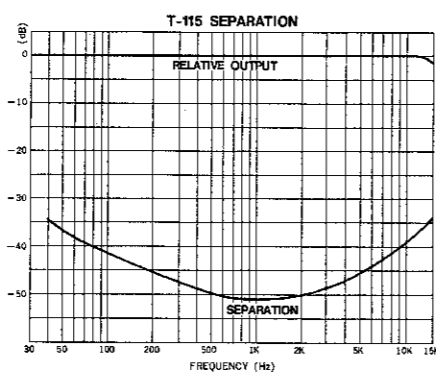
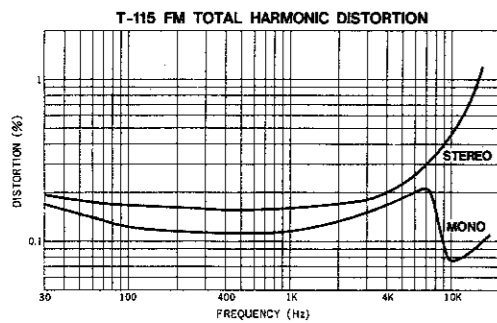
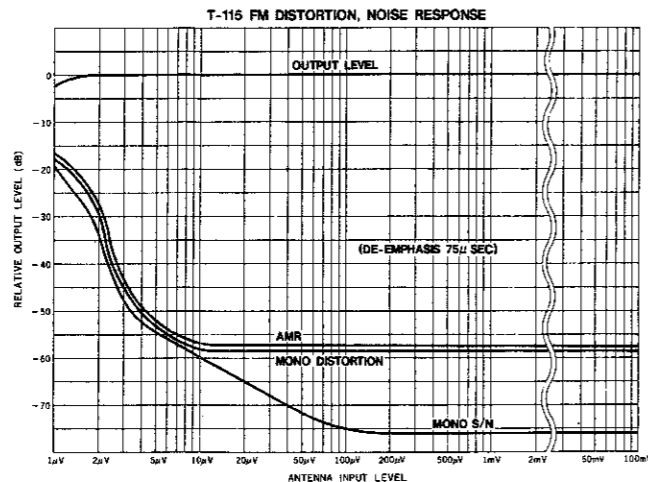
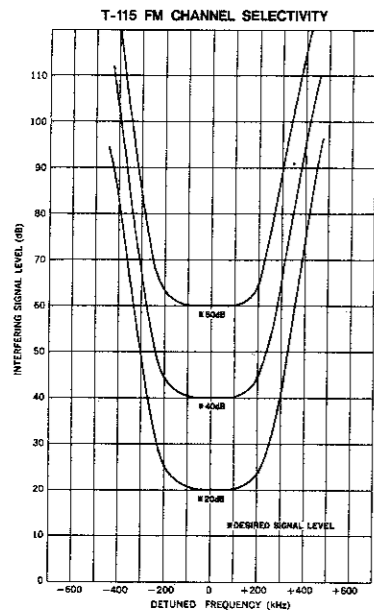

SPECIFICATIONS

<FM SECTION> (IEEE/IHF Standard)

	[MONO]	[STEREO]
Usable Sensitivity:	10.3dBf (1.8 μV)	
50dB Quieting Sensitivity:	15.6dBf (3.3 μV)	
Signal-to-Noise Ratio at 65dBf:	76dB	
Frequency Response:	30Hz - 15KHz (-1dB)	
Distortion at 65dBf:		
100Hz	0.12%	0.3%
1kHz	0.15%	0.3%
6kHz	0.2%	0.4%
Capture Ratio at 65dBf:	1.4dB	
Adjacent Channel Selectivity:	10dB	
Alternate Channel Selectivity ± 400kHz:	75dB	
Spurious Response Ratio:	85dB	
IF Response Ratio:	85dB	
Image Response Ratio:	70dB	
AM Suppression Ratio:	56dB	
Stereo Separation:	56dB	40dB
		45dB
		39dB
Subcarrier Product Ratio:	62dB	
SCA Rejection Ratio:	60dB	
Muting Threshold:	10 μV - 300mV (variable)	
Output Level:	800mV	

<AM SECTION>

Usable Sensitivity at 1MHz, 400Hz 30% mod.:	200 μV/m
Image Response Ratio at 1MHz:	50dB
IF Response Ratio at 1MHz:	40dB
Signal-to-Noise Ratio at 1MHz, 10 m V/m, 400Hz 30% mod.:	50dB
Distortion at 1MHz, 10m V/m, 400Hz/30% mod.:	0.5%

<GENERAL>

Power Consumption:	10W
Dimensions:	438 (W) x 312 (D) x 85 (H) mm (17-1/4" x 12-9/32" x 3-11/32")
Weight:	Net 5kgs (11.0 lbs.) Gross 6kgs (13.2 lbs.)

Specifications and appearance design subject to change without notice.

LUX CORPORATION, JAPAN

1-1, 1-CHOME, SHINSENRI-NISHIMACHI, TOYONAKA-SHI, OSAKA 565
PHONE: 06-834-0004 CABLE: LUXMAN TOYONAKA TELEX: J63694

Printed in Japan