

SERVICE MANUAL

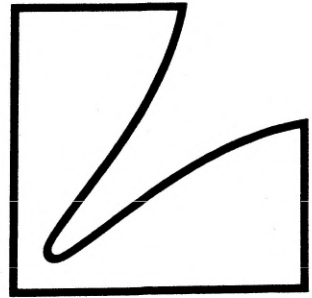

AM/FM
STEREO TUNER

T-1
(T-1L)

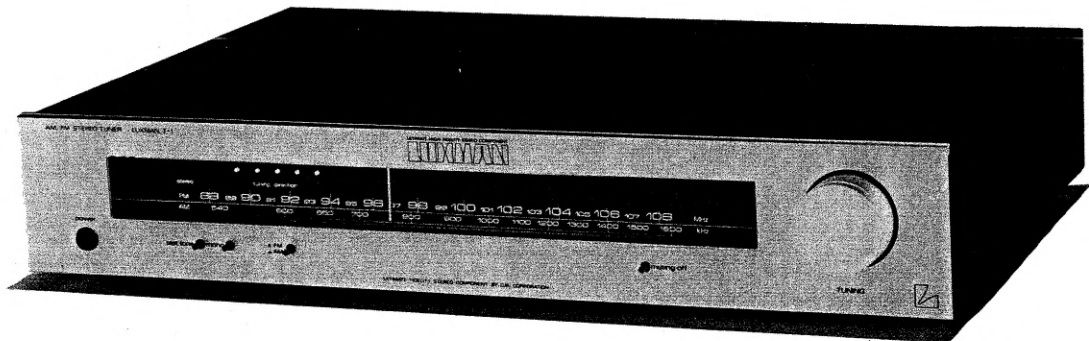

[T-1]

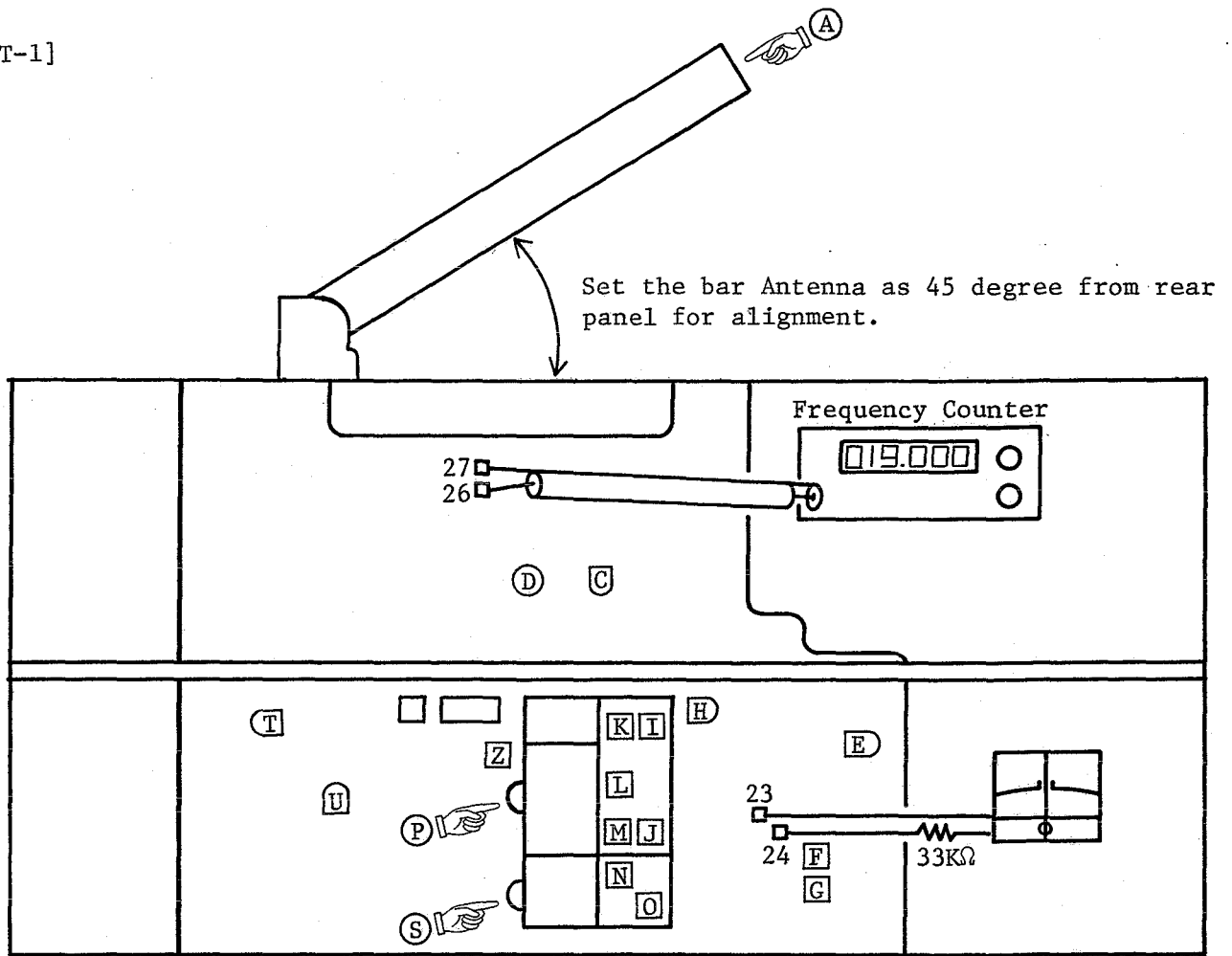

(Fig. - 1)

[T-1L]

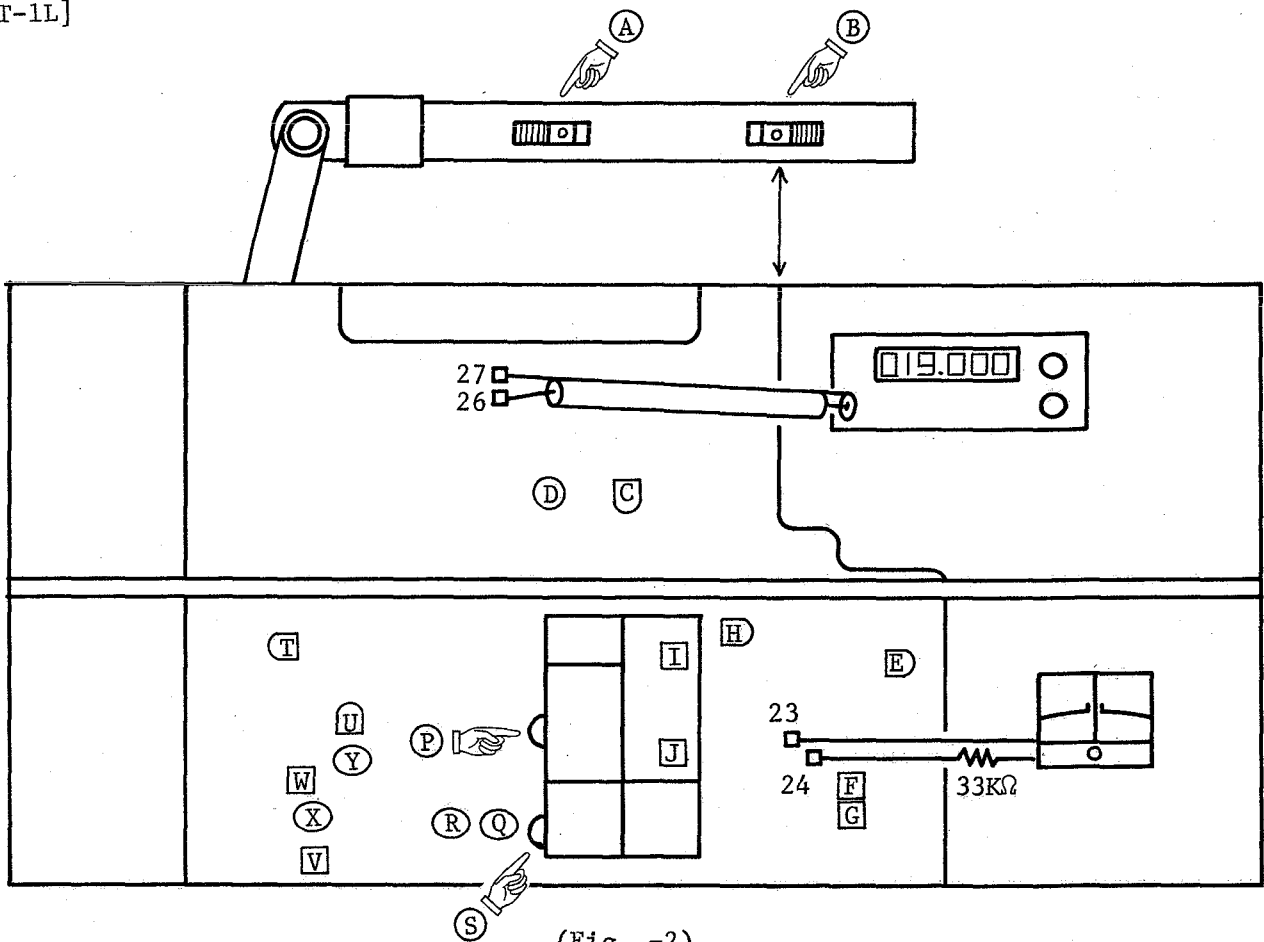

(Fig. -2)

ALIGNMENT PROCEDURES

[Test Equipment Required]

- 1) Oscilloscope
- 2) AC Volt Meter
- 3) Distortion Analyzer
- 4) FM Signal Generator (hereinafter referred to as FMSG)
- 5) Multiplex Generator
- 6) AM Signal Generator (hereinafter referred to as AMSG)
- 7) Frequency Counter
- 8) Galvanometer (-100uA, hereinafter referred to as GM)

[Connection Method of Test Equipment]

Oscilloscope	
AC Volt Meter	----- Connect to output terminal.
Distortion Analyzer	
FMSG	----- Connect to antenna terminal through matching network.
AMSG	----- Connect to loop stick antenna.

[Setup of Tuner]

Power Switch	----- Pushed on Position
Test Tone Switch	----- Pushed back Position
Mono/Stereo Switch	----- Pushed back Position
AM/FM Switch	----- Pushed back Position
Muting Switch	----- Pushed on Position
Tuning Knob	----- Check endmost starting point and tune to 108MHz.
GM (+100uA)	----- Connect Resistor 33k ohms in series to Print Terminals "23" and "24" on PB1322.

FM SECTION

[FM Tracking Adjustment]

This adjustment is necessary only in case of frontend change as all units are perfectly aligned before delivery.

1) Setup of FMSG

FMSG	108MHz
Output Level	Minimum
Modulation	+75kHz

- 2) Tune receiving frequency to 108MHz and confirm nothing is received.
- 3) Adjust "F" (T101) to let pointer of GM indicate center.
- 4) Set output level of FM SG at 2uV and tune frequency to 108MHz.
- 5) Adjust "I" of frontend to let pointer of GM indicate center.
- 6) Adjust "P" and "S" to make noise minimum.
- 7) Set FMSG at 89MHz.
- 8) Set receiving frequency of this unit in the vicinity of 89MHz and tune to let pointer of GM indicate center on receiving signal of FMSG.
- 9) In this case confirm that pointer is within plus or minus 2 calibrations on dial scale of GM.
- 10) If pointer would indicate more than plus or minus 2 calibrations, move and

adjust coil "K" of frontend to let it indicate center.

- 11) Move and adjust coils "M" and "O" to make noise minimum.
- 12) Repeat steps 1 - 11 to obtain correct tuning on dial scale.

[Muting Threshold Level]

- 1) Setup of FMSG

Frequency	98MHz
Output Level	6uV

- 2) Adjust "H" (VR101) to let output power disappear at position of muting switch pushed.

[T.H. Distortion]

- 1) Setup of FMSG.

Frequency	98MHz
Output Level	1mV

- 2) Adjust "G" (T102) to make T.H.D. minimum.

[Test Tone Output Level]

- 1) Setup of FMSG

Frequency	98MHz
Output Level	1mV

- 2) Record tuner output level.
- 3) Push tone switch and adjust "T" (VR105) to make output level at -6dB.

[MPX]

- 1) Setup of FMSG

Frequency	98MHz
Output Level	1mV
Modulation	Audio: 65.5kHz (90%) Pilot: 7.5kHz (10%)

- 2) Make modulation of FMSG off.
Connect Frequency Counter to Pin "26" on PB1322 and "27" (GND) and adjust "D" (VR103) to make frequency 19kHz +0Hz to -10Hz.
- 3) Disconnect Frequency Counter.
- 4) Give rated modulation to FMSG.
- 5) Adjust "C" (VR104) to obtain the maximum balanced separation between right and left channels.

AM SECTION

[AM - MW]

- 1) Setup of AMSG

Frequency	1400kHz
Output Level	50 - 70dB
Modulation	30% at 400Hz

2) Setup of TUNER

AM Bar Antenna Take out at 45 degrees from Rear Panel
AM/FM Selector
 Switch Push

[AM - MW Tracking]

- 1) Set frequency on AMSG and receiving frequency on Tuner both at 1400kHz.
- 2) Adjust "L" and "Z" on Fig. 1 to make noise minimum when Tuner receives signal of SG.
- 3) Set frequency of AMSG at 600kHz.
- 4) Adjust "A" and "N" on Fig. 1 to make noise minimum when Tuner receives signal of SG.
- 5) Repeat above steps 1 - 4 to obtain correct tuning on dial scale.

[Signal Strength Indication Adjustment]

- 1) Set frequency on AMSG at 1,000kHz and output level at 80dB.
- 2) Adjust "U" (VR106) on Fig. 1 to make 5 pcs. of Signal Strength Indicator LED light.

[AM - LW Tracking Adjustment --- T-1L only]

- 1) Set bar antenna of Tuner as per Fig. 2.
- 2) Set frequency of AMSG at 300kHz and modulation at 30%.
- 3) Set receiving frequency of Tuner at 300kHz.
- 4) Adjust "V" (TC503) and "Q" (TC501) to make noise minimum when Tuner receives signal of SG.
- 5) Set frequency of AMSG at 180kHz and receiving frequency of Tuner at 180kHz.
- 6) Adjust "B" and "W" (T501) to make noise minimum when Tuner receives signal of SG.
- 7) Repeat above steps 2 - 6 to obtain correct tuning on dial scale.
- 8) After adjustment, fix coil of bar antenna by adhesive, etc.

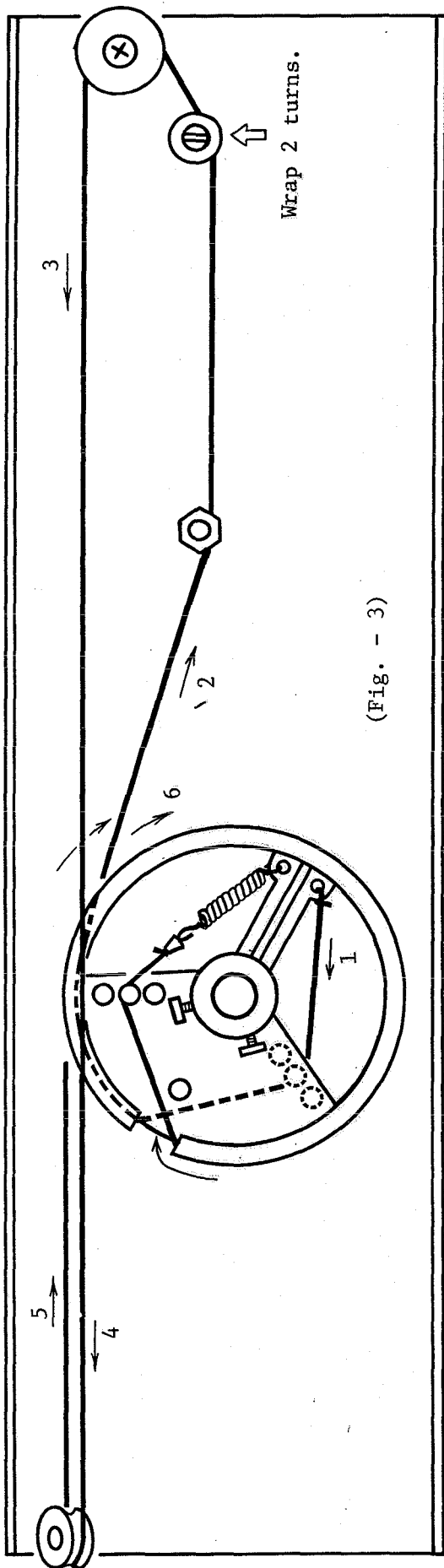

(Fig. - 3)

DIAL STRINGING PROCEDURES

- 1) Bring the variable capacitor into a state where the drum is turned to its maximum clockwise.
- 2) Tie end of new dial cord to one end of dial spring. Connect other end of dial spring of bottom See Fig. 3.
- 3) Run the dial cord through the slot in the rim of the dial drum in order as per step 1 - 8 in Fig. 3. Stretch the cord in such a tension as the spring length is elongated by 1.5 times that of the original state.
- 4) Crush eyelet and make knot. Then, cut cord leaving 5mm.
- 5) Turn the dial drum 2 or 3 times clockwise and counter-clockwise to confirm it rotates smoothly.
- 6) Fix the knot of the cord with the bond.

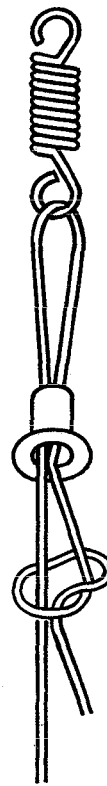

Eylet Dial Spring

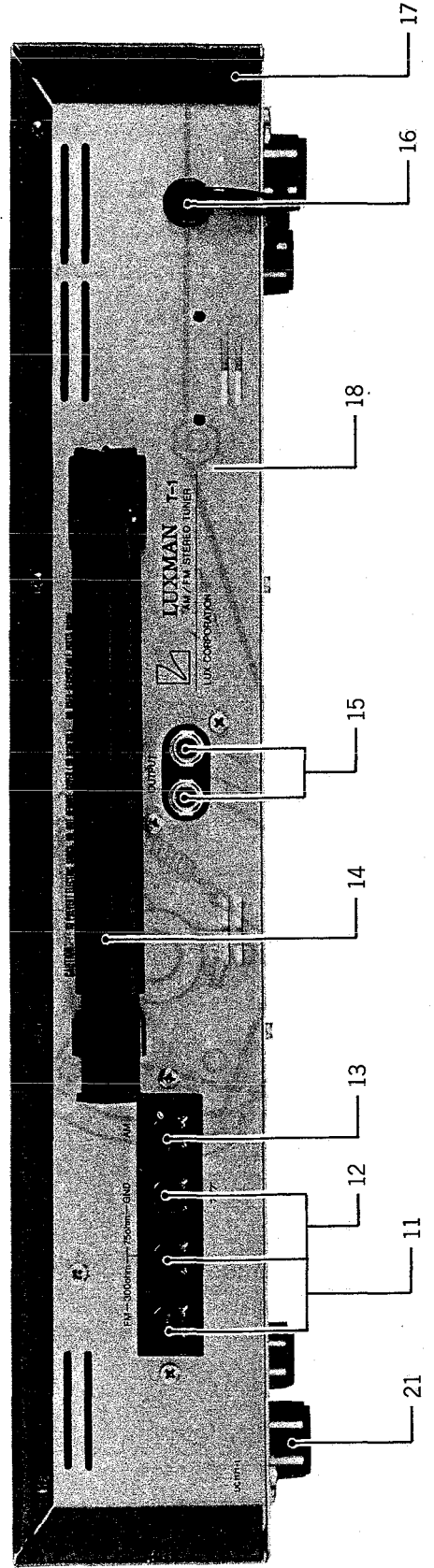
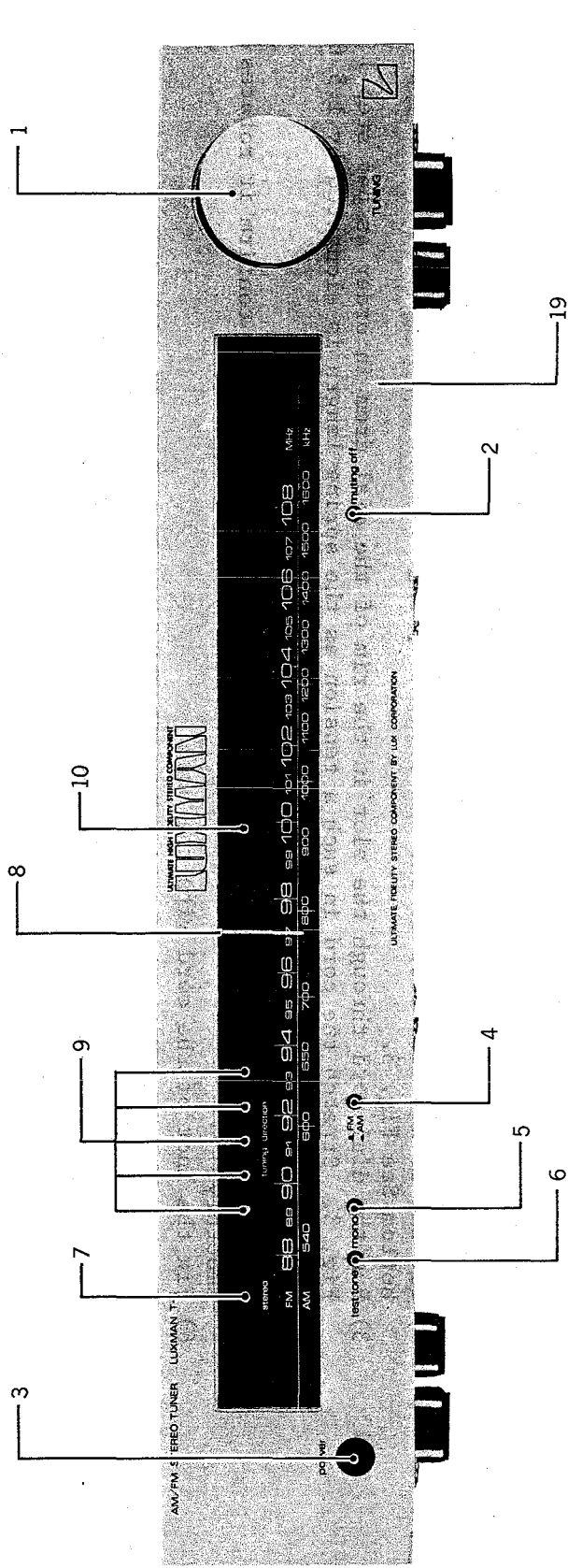

Replacement Parts List

SYMBOL NO.	PARTS NO.	DESCRIPTION AND SPECIFICATION		
C101	CK0155	Capacitor	0.01 μ F	50WV Ceramic HE70
C102	CK0157	Capacitor	0.04 μ F	25WV Ceramic C10
C103	CK0157	Capacitor	0.04 μ F	25WV Ceramic C10
C104	CK0155	Capacitor	0.01 μ F	50WV Ceramic HE70
C105	CC0038	Capacitor	5pF	50WV Ceramic HE40
C106	CK0155	Capacitor	0.01 μ F	50WV Ceramic HE70
C107	CK0155	Capacitor	0.01 μ F	50WV Ceramic HE70
C108	CK0157	Capacitor	0.04 μ F	25WV Ceramic C10
C109	CK0157	Capacitor	0.04 μ F	25WV Ceramic C10
C110	CK0157	Capacitor	0.04 μ F	25WV Ceramic C10
C111	CE0851	Capacitor	2.2 μ F	50WV U-electrolytic Radial
C112	CE0817	Capacitor	10 μ F	16WV U-electrolytic Radial
C113	CK0157	Capacitor	0.04 μ F	25WV Ceramic C10
C114	CK0157	Capacitor	0.04 μ F	25WV Ceramic C10
C115	CE0851	Capacitor	2.2 μ F	50WV U-electrolytic Radial
C116	CC0007	Capacitor	100pF	50WV Ceramic HE50
C117	CK0157	Capacitor	0.4 μ F	25WV Ceramic C10
C118	CE0849	Capacitor	0.47 μ F	50WV U-electrolytic Radial
C119	CK0157	Capacitor	0.04 μ F	25WV Ceramic C10
(C119)	CK0157	Capacitor	0.04 μ F	25WV Ceramic C10
C120	CE0821	Capacitor	100 μ F	16WV U-electrolytic Radial
C121S	CE0818	Capacitor	22 μ F	16WV U-electrolytic Radial
C122S	CK0109	Capacitor	470pF	50WV Ceramic HE40
C123	CE0818	Capacitor	22 μ F	16WV U-electrolytic Radial
C124	CE0819	Capacitor	33 μ F	16WV U-electrolytic Radial
C125	CE0818	Capacitor	22 μ F	16WV U-electrolytic Radial
C126	CK0155	Capacitor	0.01 μ F	50WV Ceramic HE70
C127	CQ0009	Capacitor	0.047 μ F	50WV Mylar YM92
C128	CQ0170	Capacitor	470pF	50WV styrol CQ09 Radial +/-5%
C129	CE0852	Capacitor	3.3 μ F	50WV U-electrolytic Radial
C130	CE0850	Capacitor	1 μ F	50WV U-electrolytic Radial
C131	CS0019	Capacitor	0.22 μ F	35WV Tantalum CS15
C132	CE0817	Capacitor	10 μ F	16WV U-electrolytic Radial
C133	CE0817	Capacitor	10 μ F	16WV U-electrolytic Radial
C134	CQ0269	Capacitor	120pF	50WV Styrol CQ09 Radial +/-5%
C135	CE0817	Capacitor	10 F	16WV U-electrolytic Radial
C136	CQ0067	Capacitor	1200pF	50WV Styrol CQ09 Radial +/-5%
C137	CQ0067	Capacitor	1200pF	50WV Styrol CQ09 Radial +/-5%
C138	^U _{EZ} CQ0210	Capacitor	620pF	50WV Styrol CQ09 Radial +/-5%
C139	^U _{EZ} CQ0210	Capacitor	620pF	50WV Styrol CQ09 Radial +/-5%
C140	CE0851	Capacitor	2.2 μ F	50WV U-electrolytic Radial
C141	CE0851	Capacitor	2.2 μ F	50WV U-electrolytic Radial
C142	CE0852	Capacitor	3.3 μ F	50WV U-electrolytic Radial
C143	CE0850	Capacitor	1 μ F	50WV U-electrolytic Radial
C144	CE0852	Capacitor	3.3 μ F	50WV U-electrolytic Radial
C145	CK0157	Capacitor	0.04 μ F	25WV Ceramic C10
C146	CE0852	Capacitor	3.3 μ F	50WV U-electrolytic Radial
C147	CE0817	Capacitor	10 μ F	16WV U-electrolytic Radial
C148	CK0155	Capacitor	0.01 μ F	50WV Ceramic HE70
C149	CK0155	Capacitor	0.01 μ F	50WV Ceramic HE70
C151	CK0157	Capacitor	0.04 μ F	25WV Ceramic C10
C152	CK0157	Capacitor	0.04 μ F	25WV Ceramic C10
C153	CK0157	Capacitor	0.04 μ F	25WV Ceramic C10
C154	CK0157	Capacitor	0.04 μ F	25WV Ceramic C10
C155	CK0157	Capacitor	0.04 μ F	25WV Ceramic C10
C156	CE0817	Capacitor	10 μ F	16WV U-electrolytic Radial
C157	CQ0013	Capacitor	0.022 μ F	50WV Mylar YM92

SYMBOL NO.	PARTS NO.	DESCRIPTION AND SPECIFICATION		
C158	CQ0013	Capacitor	0.022 μ F	50WV Mylar YM92
C159	CQ0013	Capacitor	0.022 μ F	50WV Mylar YM92
C160	CE0817	Capacitor	10 μ F	16WV U-electrolitic Radial
C161	CE0817	Capacitor	10 μ F	16WV U-electrolitic Radial
C162	CE0817	Capacitor	10 μ F	16WV U-electrolitic Radial
C163	CQ0013	Capacitor	0.022 μ F	50WV Mylar YM92
C164	CC0038	Capacitor	5pF	50WV Ceramic HE40
C165	CC0080	Capacitor	15pF	50WV Ceramic HE40
C166	CC0004	Capacitor	22pF	50WV Ceramic HE40
C167	CQ0172	Capacitor	330pF	50WV Styrol CQ09 Radial +/-5%
C168	CK0156	Capacitor	0.022 μ F	25WV Ceramic HE75
C169	CK0156	Capacitor	0.022 μ F	25WV Ceramic HE75
C170	CK0156	Capacitor	0.022 μ F	25WV Ceramic HE75
C171	CK0156	Capacitor	0.022 μ F	25WV Ceramic HE75
C172	CE0821	Capacitor	100 μ F	16WV U-electrolitic Radial
C173	CK0113	Capacitor	1000pF	50WV Ceramic HE50
C174	CE0817	Capacitor	10 μ F	16WV U-electrolitic Radial
C175	CK0155	Capacitor	0.01 μ F	50WV Ceramic HE70
C176	CK0157	Capacitor	0.04 μ F	25WV Ceramic C10
C177	CK0157	Capacitor	0.04 μ F	25WV Ceramic C10
C178	CE0817	Capacitor	10 μ F	16WV U-electrolitic Radial
C179	CE0852	Capacitor	3.3 μ F	50WV U-electrolitic Radial
C180	CK0155	Capacitor	0.01 μ F	50WV Ceramic HE70
C181	CK0130	Capacitor	4700pF	50WV Ceramic HE80
C182	CK0157	Capacitor	0.04 μ F	25WV Ceramic C10
C183	CE0836	Capacitor	1000 μ F	25WV U-electrolitic Radial
C184	CE0846	Capacitor	470 μ F	35WV U-electrolitic Radial
C185	CE0833	Capacitor	220 μ F	25WV U-electrolitic Radial
C186	CE0821	Capacitor	100 μ F	16WV U-electrolitic Radial
C187	CE0817	Capacitor	10 μ F	16WV U-electrolitic Radial
C189	CK0157	Capacitor	0.04 μ F	25WV Ceramic C10
C191E	CU0033	Capacitor	0.022 μ F	250WV Linepass PME
C191S	CU0041	Capacitor	0.022 μ F	250WV Linepass PME
C191U	CU0076			
C192E	CU0033	Capacitor	0.022 μ F	250WV Linepass PME
C192S	CU0041	Capacitor	0.022 μ F	250WV Linepass PME
C193	CK0157	Capacitor	0.04 μ F	25WV Ceramic C10
C194	CK0155	Capacitor	0.01 μ F	50WV Ceramic HE70
C195	CK0155	Capacitor	0.01 μ F	50WV Ceramic HE70
C196	CK0155	Capacitor	0.01 μ F	50WV Ceramic HE70
C197	CK0157	Capacitor	0.04 μ F	25WV Ceramic C10
D101	TD0197	Diode	US1070	
D102	TD0197	Diode	US1070	
D103	TD0197	Diode	US1070	
D104	TD0197	Diode	US1070	
D105	TD0197	Diode	US1070	
D106	TD0197	Diode	US1070	
D107	TD0203	LED SEL1112R		
D108	TD0203	LED SEL1112R		
D109	TD0203	LED SEL1112R		
D110	TD0203	LED SEL1112R		
D111	TD0203	LED SEL1112R		
D112	TD0203	LED SEL1112R		
D113	TD0168	D SISY-20		
D114	TD0168	D SISY-20		
D115	TD0197	Diode	US1070	
D116	TD0079	Diode Zener	WZ140	14V
D117	TD0079	Diode Zener	WZ140	14V
D118	TV0030	Diode Varistor	KB265-C4	
D119	TD0197	Diode	US1070	

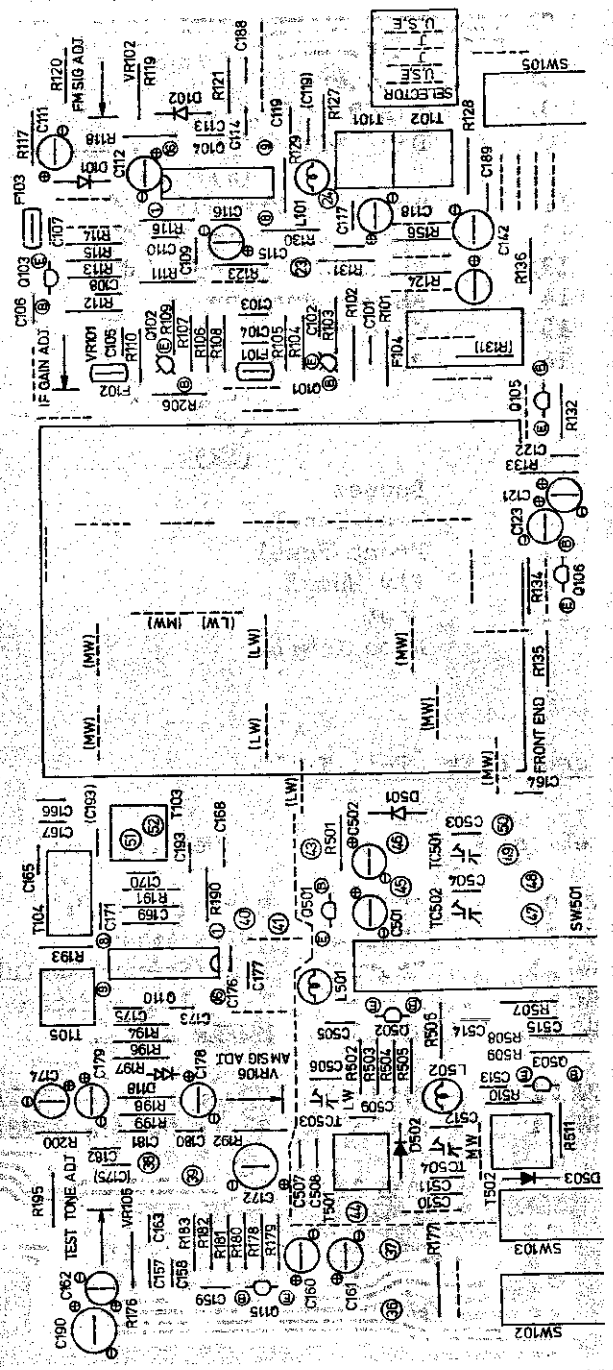
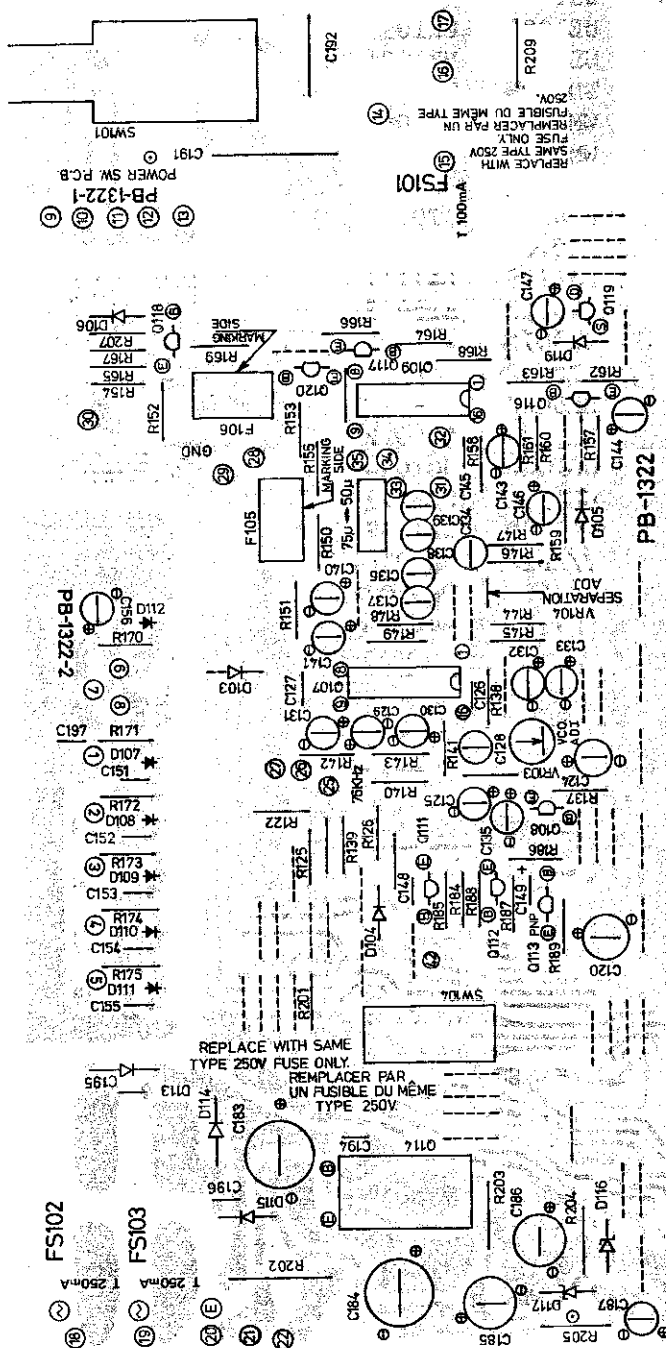

Parts List

Ref. No.	Description	T-1	T-1L
1	Knob (tuning) (UC, UZ, EK, SK) (J)	WH1104 WH1103	WH1104 -
2	Knob (Muting)	WJ1140	WJ1140
3	Knob (Power)	WJ1133	WJ1133
4	Knob (AM/FM)	WJ1140	WJ1140
5	Knob (Mono/Stereo)	WJ1140	WJ1140
6	Knob (test tone)	WJ1140	WJ1140
7	Protector	UE1093	UE1093
8	Pointer	UZ1191	UZ1191
9	L.E.D. (SEL1112R)	TD0203	TD0203
10	Dial Scale (UC, UZ, EK, SK) (J)	WM1061 WM1060	WM1062 -
11	Antenna terminal (FM)	AT0121	AT0121
12	Antenna terminal (FM)	AT0121	AT0121
13	Antenna terminal (AM)	AT0121	AT0121
14	AM Bar Antenna	LA1129	LA1117
15	Output terminal	AT5017	AT5017
16	Power Cord (J) (UC, UZ) (EK) (SK)	BK0015 BK0018 BK0022 BK0022	- - - BK0022
17	Bonnet	UG1024	UG1024
18	Rear Panel	UC1171	UC1173
19	Front Panel	WA1200	WA1202
20	Fly Wheel	UX1014	UX1014
21	Foot	WN0007	WN0007
4'	Knob (MW/LW)	-	WJ1140

Parts List T-1, T-1L

Ref. No.	Code	Description	Remarks
SW105	SP0162	Muting Switch	
SW104	SP0164	AM/FM Switch	
SW103	SP0163	Mono/Stereo Switch	
SW102	SP0163	Test Tone Switch	
SWa ~ f	SP0150	MW/LW Switch	T-1L
SW101	SP0151	Power Switch SDU1P	E, S
SW101	SP0152	Power Switch SDU3P	U, J
	PT2472	Power Trans Former	U
	PT2473	"	S
	PT2474	"	E
	PT2471	"	J
	PT2519	"	(220V only)
	LA1923	Front End (FF111U22)	E, S, U
	LA1922	" (FF111J15)	J
PL	AL0039	Lamp	

SYMBOL NO.	PARTS NO.	DESCRIPTION AND SPECIFICATION			
F104S	LA1192	Anti-bardie Filter	Lux-1192		
F105	LA1196	Low-pass Filter	BL-30HJ		
F106	LA1196	Low-pass Filter	BL-30HJ		
L101	LA1173	CHOKe Coil	S-220J		
Q101	TR0092	Transistor	2SC1674		
Q102	TR0019	Transistor	2SC1923		
Q103	TR0019	Transistor	2SC1923		
Q104	TC0099	IC	LA1231NS		
Q105	TR0198	Transistor	2SC1815		
Q106	TR0198	Transistor	2SC1815		
Q107	TC0094	IC	UPC1161C		
Q108	TR0198	Transistor	2SC1815		
Q109	TC0173	IC	BA685		
Q110	TC0021	IC	HA1197		
Q111	TR0198	Transistor	2SC1815		
Q112	TR0198	Transistor	2SC1815		
Q113	TR0087	Transistor	2SA1015		
Q114	TR5012	Transistor	2SD880		
Q115	TR0198	Transistor	2SC1815		
Q116	TR0198	Transistor	2SC1815		
Q117	TR0198	Transistor	2SC1815		
Q118	TR0198	Transistor	2SC1815		
Q119	TF0030	FET	2SK117Y		
Q120	TR0198	Transistor	2SC1815		
R101	RB0364	Resistor	470 OHM	0.25W +/-5%	Carbon RD25S
R102	RB0390	Resistor	5.6K OHM	0.25W +/-5%	Carbon RD25S
R103	RB0344	Resistor	68 OHM	0.25W +/-5%	Carbon RD25S
R104	RB0360	Resistor	330 OHM	0.25W +/-5%	Carbon RD25S
R105	RB0348	Resistor	100 OHM	0.25W +/-5%	Carbon RD25S
R106	RB0348	Resistor	100 OHM	0.25W +/-5%	Carbon RD25S
R107	RB0364	Resistor	470 OHM	0.25W +/-5%	Carbon RD25S
R108	RB0382	Resistor	2.7K OHM	0.25W +/-5%	Carbon RD25S
R108	RB0364	Resistor	470 OHM	0.25W +/-5%	Carbon RD25S
R110	RB0360	Resistor	330 OHM	0.25W +/-5%	Carbon RD25S
R111	RB0348	Resistor	100 OHM	0.25W +/-5%	Carbon RD25S
R112	RB0388	Resistor	4.7K OHM	0.25W +/-5%	Carbon RD25S
R113	RB0414	Resistor	56K OHM	0.25W +/-5%	Carbon RD25S
R114	RB0344	Resistor	68 OHM	0.25W +/-5%	Carbon RD25S
R115	RB0360	Resistor	330 OHM	0.25W +/-5%	Carbon RD25S
R116	RB0364	Resistor	470 OHM	0.25W +/-5%	Carbon RD25S
R117	RB0416	Resistor	68K OHM	0.25W +/-5%	Carbon RD25S
R118	RB0400	Resistor	15K OHM	0.25W +/-5%	Carbon RD25S
R119	RB0406	Resistor	27K OHM	0.25W +/-5%	Carbon RD25S
R120	RB0412	Resistor	47K OHM	0.25W +/-5%	Carbon RD25S
R121	RB0348	Resistor	100 OHM	0.25W +/-5%	Carbon RD25S
R122	RB0396	Resistor	10K OHM	0.25W +/-5%	Carbon RD25S
R123	RB0414	Resistor	56K OHM	0.25W +/-5%	Carbon RD25S
R124	RB0404	Resistor	22K OHM	0.25W +/-5%	Carbon RD25S
R125	RB0396	Resistor	10K OHM	0.25W +/-5%	Carbon RD25S
R126	RB0396	Resistor	10K OHM	0.25W +/-5%	Carbon RD25S
R127	RB0394	Resistor	8.2K OHM	0.25W +/-5%	Carbon RD25S
R128	RB0378	Resistor	1.8K OHM	0.25W +/-5%	Carbon RD25S
R129	RB0356	Resistor	220 OHM	0.25W +/-5%	Carbon RD25S
R130	RB0406	Resistor	27K OHM	0.25W +/-5%	Carbon RD25S
R131E	RB0364	Resistor	470 OHM	0.25W +/-5%	Carbon RD25S
R131J	RB0364	Resistor	470 OHM	0.25W +/-5%	Carbon RD25S
R131S	RB0396	Resistor	10K OHM	0.25W +/-5%	Carbon RD25S
R131U	RB0364	Resistor	470 OHM	0.25W +/-5%	Carbon RD25S

SYMBOL NO.	PARTS NO.	DESCRIPTION AND SPECIFICATION			
R132S	RB0396	Resistor	10K OHM	0.25W +/-5%	Carbon RD25S
R133	RB0388	Resistor	4.7K OHM	0.25W +/-5%	Carbon RD25S
R134E	RB0402	Resistor	18K OHM	0.25W +/-5%	Carbon RD25S
R134J	RB0402	Resistor	18K OHM	0.25W +/-5%	Carbon RD25S
R134S	RB0392	Resistor	6.8K OHM	0.25W +/-5%	Carbon RD25S
R134U	RB0402	Resistor	18K OHM	0.25W +/-5%	Carbon RD25S
R135E	RB0406	Resistor	27K OHM	0.25W +/-5%	Carbon RD25S
R135J	RB0406	Resistor	27K OHM	0.25W +/-5%	Carbon RD25S
R135S	RB0408	Resistor	33K OHM	0.25W +/-5%	Carbon RD25S
R135U	RB0406	Resistor	27K OHM	0.25W +/-5%	Carbon RD25S
R136	RB0396	Resistor	10K OHM	0.25W +/-5%	Carbon RD25S
R137	RB0384	Resistor	3.3K OHM	0.25W +/-5%	Carbon RD25S
R138E	RB0404	Resistor	22K OHM	0.25W +/-5%	Carbon RD25S
R138J	RB0404	Resistor	22K OHM	0.25W +/-5%	Carbon RD25S
R138S	RB0400	Resistor	15K OHM	0.25W +/-5%	Carbon RD25S
R138U	RB0404	Resistor	22K OHM	0.25W +/-5%	Carbon RD25S
R141	RB0400	Resistor	15K OHM	0.25W +/-5%	Carbon RD25S
R142	RB0378	Resistor	1.8K OHM	0.25W +/-5%	Carbon RD25S
R143	RB0372	Resistor	1K OHM	0.25W +/-5%	Carbon RD25S
R144	RB0404	Resistor	22K OHM	0.25W +/-5%	Carbon RD25S
R145	RB0404	Resistor	22K OHM	0.25W +/-5%	Carbon RD25S
R146	RB0390	Resistor	5.6K OHM	0.25W +/-5%	Carbon RD25S
R147	RB0390	Resistor	5.6K OHM	0.25W +/-5%	Carbon RD25S
R148	RB0412	Resistor	47K OHM	0.25W +/-5%	Carbon RD25S
R149	RB0412	Resistor	47K OHM	0.25W +/-5%	Carbon RD25S
R150	RB0384	Resistor	3.3K OHM	0.25W +/-5%	Carbon RD25S
R151	RB0384	Resistor	3.3K OHM	0.25W +/-5%	Carbon RD25S
R152	RB0384	Resistor	3.3K OHM	0.25W +/-5%	Carbon RD25S
R153	RB0384	Resistor	3.3K OHM	0.25W +/-5%	Carbon RD25S
R154	RB0356	Resistor	220 OHM	0.25W +/-5%	Carbon RD25S
R155	RB0356	Resistor	220 OHM	0.25W +/-5%	Carbon RD25S
R156	RB0398	Resistor	12K OHM	0.25W +/-5%	Carbon RD25S
R157	RB0388	Resistor	4.7K OHM	0.25W +/-5%	Carbon RD25S
R158	RB0412	Resistor	47K OHM	0.25W +/-5%	Carbon RD25S
R159	RB0388	Resistor	4.7K OHM	0.25W +/-5%	Carbon RD25S
R160	RB0412	Resistor	47K OHM	0.25W +/-5%	Carbon RD25S
R161	RB0412	Resistor	47K OHM	0.25W +/-5%	Carbon RD25S
R162	RB0412	Resistor	47K OHM	0.25W +/-5%	Carbon RD25S
R163	RB0412	Resistor	47K OHM	0.25W +/-5%	Carbon RD25S
R164	RB0412	Resistor	47K OHM	0.25W +/-5%	Carbon RD25S
R165	RB0396	Resistor	10K OHM	0.25W +/-5%	Carbon RD25S
R166	RB0412	Resistor	47K OHM	0.25W +/-5%	Carbon RD25S
R167	RB0436	Resistor	470K OHM	0.25W +/-5%	Carbon RD25S
R168	RB0364	Resistor	470 OHM	0.25W +/-5%	Carbon RD25S
R169	RB0410	Resistor	39K OHM	0.25W +/-5%	Carbon RD25S
R170	RB0396	Resistor	10K OHM	0.25W +/-5%	Carbon RD25S
R171	RB0378	Resistor	1.8K OHM	0.25W +/-5%	Carbon RD25S
R172	RB0378	Resistor	1.8K OHM	0.25W +/-5%	Carbon RD25S
R173	RB0378	Resistor	1.8K OHM	0.25W +/-5%	Carbon RD25S
R174	RB0378	Resistor	1.8K OHM	0.25W +/-5%	Carbon RD25S
R175	RB0378	Resistor	1.8K OHM	0.25W +/-5%	Carbon RD25S
R176	RB0414	Resistor	56K OHM	0.25W +/-5%	Carbon RD25S
R177	RB0372	Resistor	1K OHM	0.25W +/-5%	Carbon RD25S
R178	RB0388	Resistor	4.7K OHM	0.25W +/-5%	Carbon RD25S
R179	RB0372	Resistor	1K OHM	0.25W +/-5%	Carbon RD25S
R180	RB0418	Resistor	82K OHM	0.25W +/-5%	Carbon RD25S
R181	RB0398	Resistor	12K OHM	0.25W +/-5%	Carbon RD25S
R182	RB0388	Resistor	4.7K OHM	0.25W +/-5%	Carbon RD25S
R183	RB0388	Resistor	4.7K OHM	0.25W +/-5%	Carbon RD25S
R184	RB0392	Resistor	6.8K OHM	0.25W +/-5%	Carbon RD25S
R185	RB0416	Resistor	68K OHM	0.25W +/-5%	Carbon RD25S

SYMBOL NO.	PARTS NO.	DESCRIPTION AND SPECIFICATION			
R186	RB0386	Resistor	3.9K OHM	0.25W +/-5%	Carbon RD25S
R187	RB0420	Resistor	100K OHM	0.25W +/-5%	Carbon RD25S
R188	RB0348	Resistor	100 OHM	0.25W +/-5%	Carbon RD25S
R189	RB0388	Resistor	4.7K OHM	0.25W +/-5%	Carbon RD25S
R190	RB0324	Resistor	10 OHM	0.25W +/-5%	Carbon RD25S
R191	RB0376	Resistor	1.5K OHM	0.25W +/-5%	Carbon RD25S
R192	RB0356	Resistor	220 OHM	0.25W +/-5%	Carbon RD25S
R193	RB0390	Resistor	5.6K OHM	0.25W +/-5%	Carbon RD25S
R194	RB0360	Resistor	330 OHM	0.25W +/-5%	Carbon RD25S
R195	RB0348	Resistor	100 OHM	0.25W +/-5%	Carbon RD25S
R196	RB0396	Resistor	10K OHM	0.25W +/-5%	Carbon RD25S
R197	RB0396	Resistor	10K OHM	0.25W +/-5%	Carbon RD25S
R198	RB0382	Resistor	2.7K OHM	0.25W +/-5%	Carbon RD25S
R199	RB0400	Resistor	15K OHM	0.25W +/-5%	Carbon RD25S
R200E	RB0392	Resistor	6.8K OHM	0.25W +/-5%	Carbon RD25S
R200J	RB0392	Resistor	6.8K OHM	0.25W +/-5%	Carbon RD25S
R200S	RB0386	Resistor	3.9K OHM	0.25W +/-5%	Carbon RD25S
R200U	RB0392	Resistor	6.8K OHM	0.25W +/-5%	Carbon RD25S
R201	RB0372	Resistor	1K OHM	0.25W +/-5%	Carbon RD25S
R202	RS3069	Resistor	82 OHM	1W +/-5%	FLAME PROOF
R203	RD2574	Resistor	470 OHM	0.5W +/-5%	Carbon RD1/2
R204	RD0470	Resistor	470 OHM	0.25W +/-5%	Carbon RD1/4S
R205	RD2574	Resistor	470 OHM	0.5W +/-5%	Carbon RD1/2
R206	RB0348	Resistor	100 OHM	0.25W +/-5%	Carbon RD25S
R207	RB0412	Resistor	47K OHM	0.25W +/-5%	Carbon RD25S
R209	RD0100	Resistor	2.2M OHM	0.25W +/-5%	Carbon RD1/2
T101	LA5021	FM Transformer	LUX5021		
T102	LA5022	FM Transformer	LUX5022		
T103	LA1073	AM Transformer	LUX-1073		
T104	LA1098	AM Transformer	FSN-1067		
T105	LA1100	AM Transformer	LA-1100		
VR101	RT0054	SEMI Fixed Resistor	300 OHM B		KVSF8-7PNFX
VR102	RT0052	SEMI Fixed Resistor	20K OHM B		KVSF8-7PNFX
VR103	RT0025	SEMI Fixed Resistor	4.7K OHM B		SR19R
VR104	RT0109	SEMI Fixed Resistor	500K OHM B		KVSF8-7PNFX
VR105	RT0086	SEMI Fixed Resistor	10K OHM B		KVSF8-7PNFX
VR106	RT0051	SEMI Fixed Resistor	5K OHM B		KVSF8-7PNFX

	FS101	FS102	FS103
S	T 100mA	T 250mA	T 250mA
J	0.2A	0.5A	0.5A
U	0.2A	0.5A	0.5A
E	EK: 0.1A EZ: 0.2A	0.5A	0.5A

Parts List T1-L Only

Ref. No.	Code	Description				
C503	CC0004	22pF	50V ± 10%	T501	LA1095	LW TRANS FORMER
C505	CC0005	33pF	50V ± 10%	T502	LA1073	AM TRANS FORMER
C506	CC0006	47pF	50V ± 10%			
C507	CQ0205	150pF	50V ± 5%	Q502	TR0092	2SC1674
C508	CC0004	22pF	50V ± 10%	Q503	TR0092	2SC1674
C509	CC0156	0.022μF	25V			
C510	CQ0172	330pF	50V ± 5%	D502	TD0018	1K-188FM
C511	CC0080	15pF	50V ± 10%	D503	TD0018	1K-188FM
C512	CC0012	10pF	50V ± 10%			
C513	CK0156	0.022μF	25V	R502	RB0324	10 Ω 1/4w ± 5%
C514	CK0156	0.022μF	25V	R503	RB0382	2.7K
C515	CK0156	0.022μF	25V	R504	RB0340	47
				R505	RB0394	8.2K
TC501	CT0008	20pF	TRIMMER	R506	RB0412	47K
TC502	CT0008	20pF	TRIMMER	R507	RB0408	33K
TC503	CT0008	20pF	TRIMMER	R508	RB0394	8.2K
TC504	CT0008	20pF	TRIMMER	R509	RB0382	2.7K
				R510	RB0324	10
				R511	RB0340	47

SPECIFICATIONS

[FM SECTION](IEEE/IHF Standard)	(MONO)	(STEREO)
Usable Sensitivity:	10.8dBf(1.9μV)	
50dB Quieting Sensitivity:	16.0dBf(3.5μV)	
Signal-to-Noise Ratio at 65dBf:	75dB(IHF A weighted)	
Frequency Response:	-1dB(30Hz-15kHz)	
Distortion at 65dBf:	100Hz	0.15% 0.3%
	1kHz	0.15% 0.3%
	6kHz	0.3% 0.5%
Capture Ratio at 65dBf:	1.4dB	
Adjacent Channel Selectivity:	10dB	
Alternate Channel Selectivity ±400kHz:	75dB	
Spurious Response Ratio:	80dB	
IF Response Ratio:	90dB	
Image Response Ratio:	55dB	
AM Suppression Ratio:	55dB	
Stereo Separation:	100Hz	40dB
	1kHz	45dB(38dB with birdie filter)
	10kHz	38dB

Subcarrier Product Ratio:	62dB
SCA Rejection Ratio:	60dB
Muting Threshold:	5μV
Output Level:	700mV
[AM SECTION]	
Usable Sensitivity at 1MHz, 400Hz 30% mod:	220μV/m
Image Response Ratio at 1MHz:	50dB
IF Response Ratio at 1MHz:	40dB
Signal-to-Noise Ratio at 1MHz, 10mV/m,	
	400Hz 30% mod:
Distortion at 1MHz, 10mV/m, 400Hz 30% mod:	0.5%
[GENERAL]	
Power Consumption:	7W
Dimensions:	438(W)×312(D)×85(H)mm
	(17-1/4"×12-9/32"×3-11/32")
Weight:	Net 5.0kgs(11.0 lbs.)
	Gross 6.0kgs(13.2 lbs.)

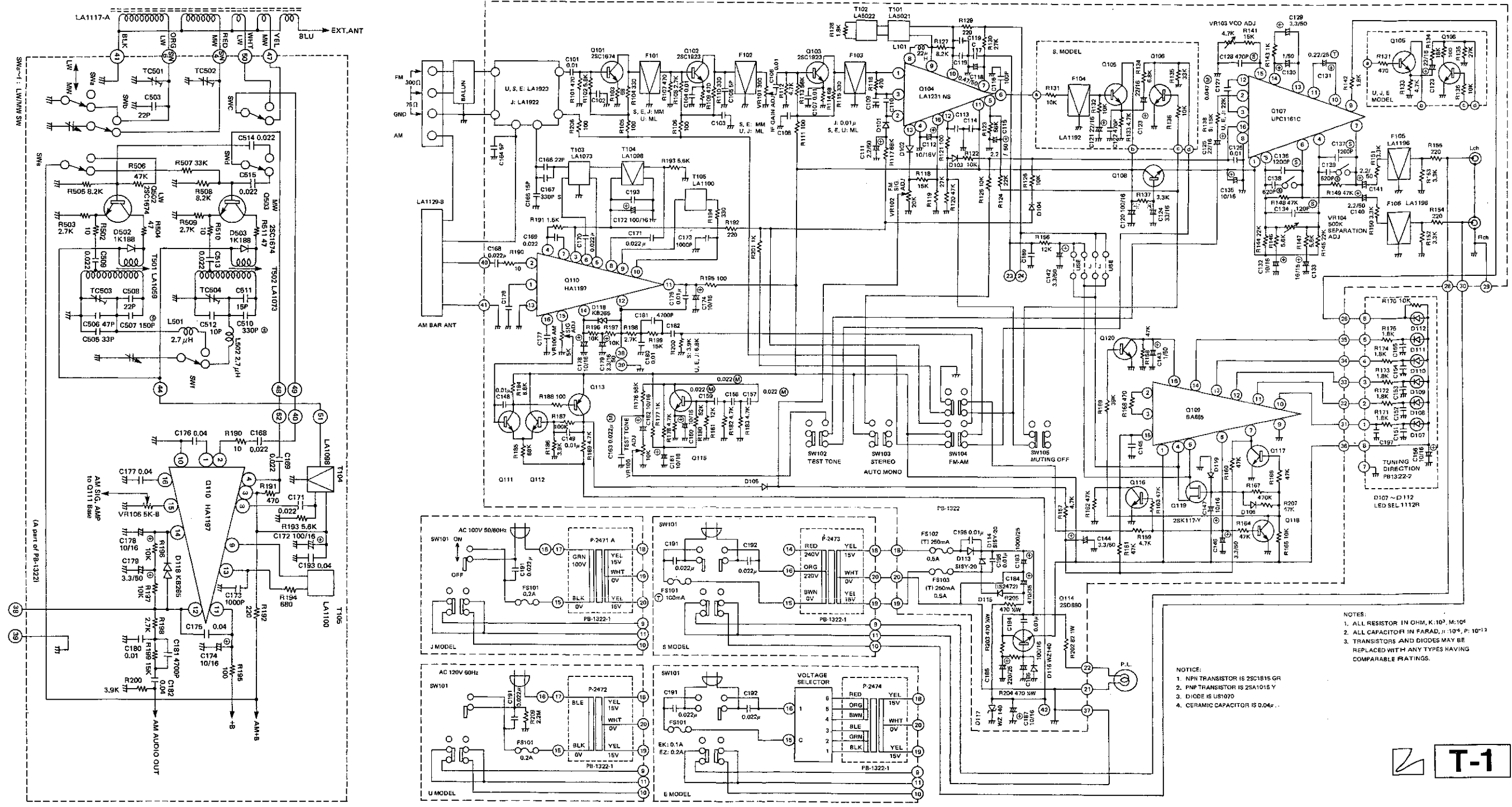
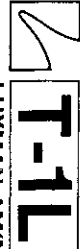

NOTES:
 1. ALL RESISTOR IN OHM, K. 10³, M. 10⁶
 2. ALL CAPACITOR IN FARAD, μ. 10⁻⁶, P. 10⁻¹²
 3. TRANSISTORS AND DIODES MAY BE REPLACED WITH ANY TYPES HAVING COMPARABLE RATINGS.

NOTICE:
 1. NPN TRANSISTOR IS 2SC1815 GR
 2. PNP TRANSISTOR IS 2SA1015 Y
 3. DIODE IS 1S1070
 4. CERAMIC CAPACITOR IS 0.04μ

