

SERVICE MANUAL

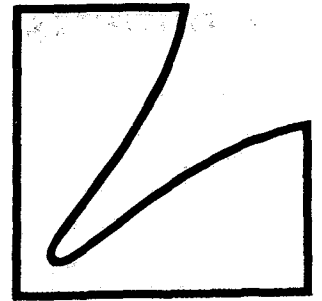

AM/FM Tuner-Amplifier **R-5030**

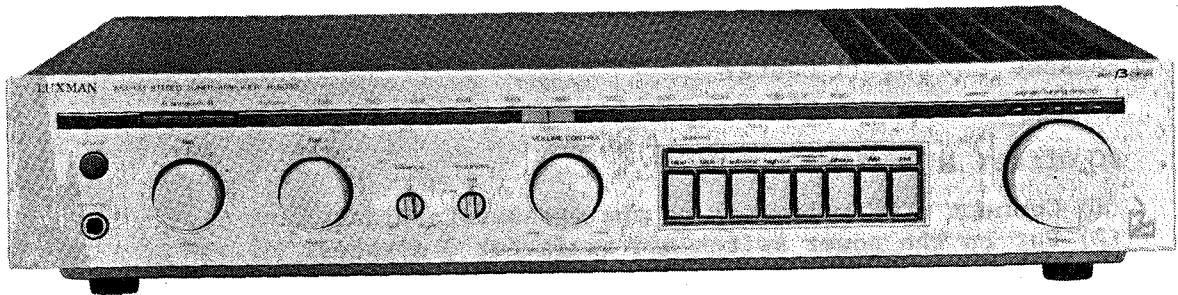

Contents

Alignment Procedures	1 ~ 4
Exploded View	5
Exploded Parts List	6
PB-1396 Parts List	7 ~ 10
PB-1377 Parts List	11 ~ 13
PB-1397 Parts List	13
PB-1378 Parts List	13
PB-1391 Parts List	13
Schematic Diagram Audio (UC)	14
Schematic Diagram Audio	15
Schematic Diagram RF	16
Schematic Diagram RF (UC)	17
Specifications	18
Specifications (UC)	19

Receiver Alignment Procedures

This unit was already aligned at the factory prior to shipment but in case that re-alignment is necessary for any reasons such as replacement of the front-end, etc., please make alignment with the following procedures:

Audio Section Alignment

1. Set the switches of this unit as follows:

Volume Control : Minimum
 Tone Control : Flat
 Speaker Selector : A
 Balance : Center
 Loudness : Off

2. DC Offset Adjustment

- (1) Connect a DC voltmeter to the speaker terminals.
- (2) Put on the power switch and await for 3 minutes.
- (3) Adjust the semi-fixed resistors, VR803a (L-ch) and VR803b (R-ch) on the PB-1377 to make the DC voltmeter connected to the speaker terminals read 0V.

3. Idling Current Adjustment

- (1) Put off the power switch.
- (2) Remove the fuses, F801a (L-ch) and F801b (R-ch) from the PB-1377 and connect an DC voltmeter to the terminals. (Be careful about the right connection to the positive and negative terminals of the DC voltmeter. See Fig. 1.)
- (3) Put on the power switch and await for 3 minutes.
- (4) Adjust the semi-fixed resistors, VR804a (L-ch) and VR804b (R-ch) on the PB-1377 to make the DC voltmeter connected to the fuse terminals read 50mA.

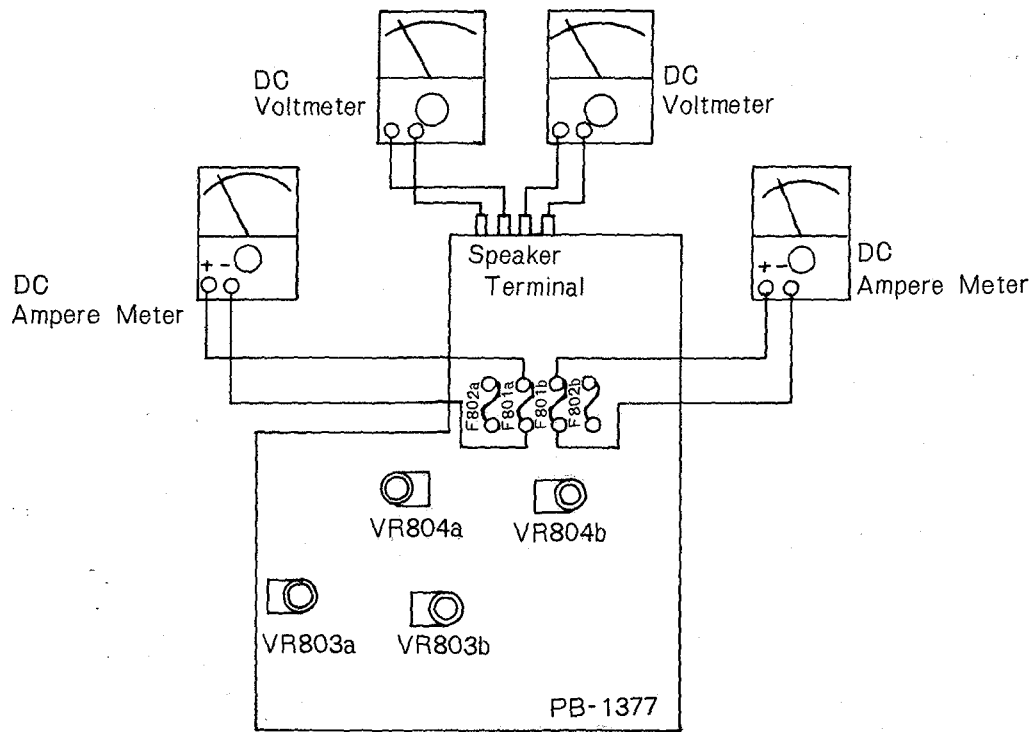

-----Fig. 1.-----

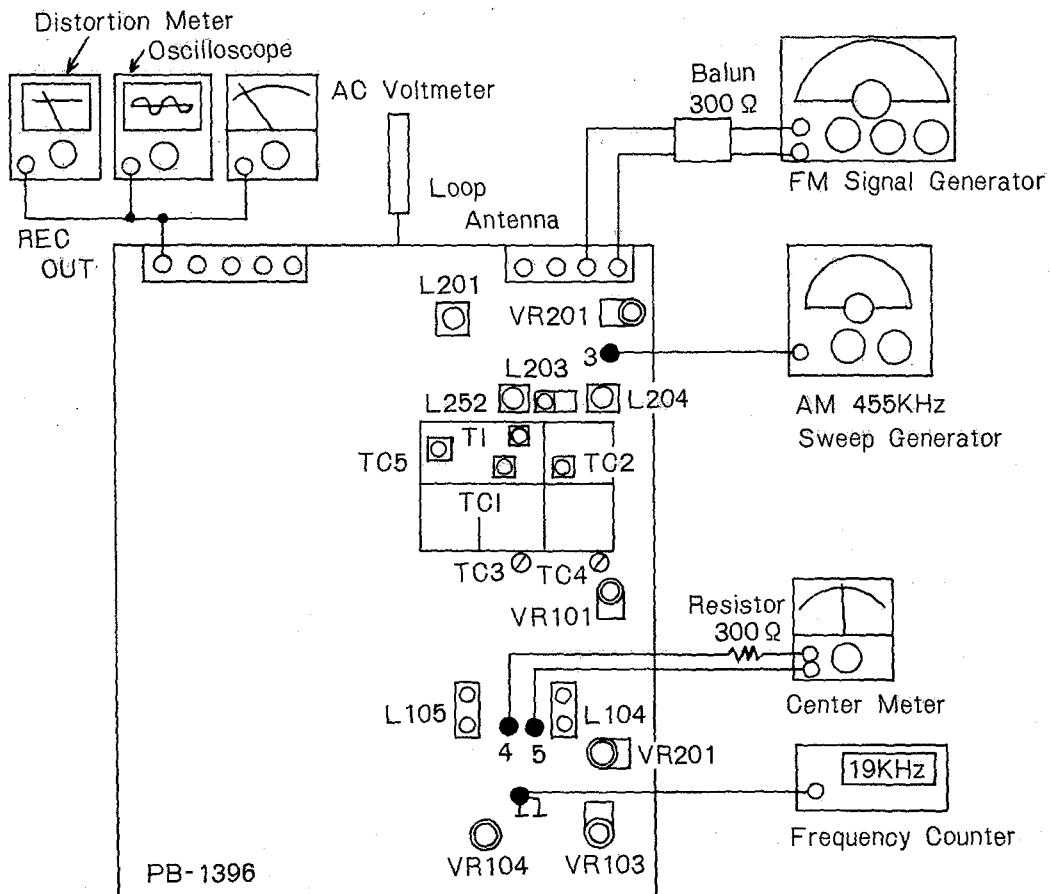

-----Fig. 2.-----

AM Alignment

1. Set the switches of this unit as follows:

- Subsonic : Off
- High Cut : Off
- Mono : Off
- Tape : Off
- AM : On

2. AM IF Adjustment

- (1) Connect a 455KHz sweep generator to No. 3 terminal on the PB-1396. (See Fig. 2.)
- (2) Connect a AC voltmeter and an oscilloscope to REC OUT.
- (3) Adjust the IF coils, L203 and L204 to make the AC voltmeter read maximum and also to make the wave form on the oscilloscope ideal. (See Fig. 3.)

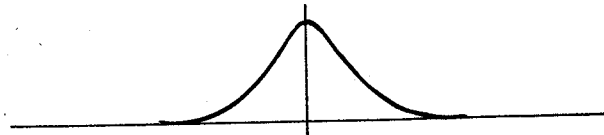

(4) Disconnect the 455KHz sweep generator.

3. AM Tracking and Sensitivity Adjustment

- (1) Set the loop antenna of this unit at a right angle to the rear panel.
- (2) Set an AM signal generator at 50cm away from the center of the loop antenna.
- (3) Make output of the AM signal generator at 1,400KHz and set the dial pointer at 1,400KHz on the dial scale by the tuning knob. Adjust the local oscillator trimmer capacitor, TC2 and the trimmer capacitor for sensitivity adjustment, TC1 to make REC OUT output maximum.
- (4) Make output of the AM signal generator at 600KHz and set the dial pointer at 600KHz on the dial scale by the tuning knob. Adjust the local oscillator trimmer coil on PB-1396, L252 and the trimmer coil for sensitivity adjustment, L201 to make REC OUT output maximum.
- (5) Repeat adjustment as per the foregoing step, (3) & (4) for a few times and confirm that the tracking meets as rated.

4. AM Strength Adjustment

- (1) Make output of the AM signal generator 100dB/m, 1,000KHz and make this unit receive the foregoing 1,000KHz.
- (2) Adjust the semi-fixed resistor on the PB-1396, VR201 to make all of 5 signal strength L.E.D.'s light up.

FM Alignment

1. Set the switches of this unit as follows:

- Low Cut : Off
- High Cut : Off
- Tape : Off
- Mono : On
- FM : On

2. FM IF Adjustment

- (1) Connect an FM signal generator to the 300-ohm FM antenna terminal of this unit through the 300-ohm balun.
- (2) Connect the center meter through the 300-ohm resistor to the terminal Nos. 4 & 5 on the PB-1396. (See Fig. 2.)
- (3) Connect an AC voltmeter, an oscilloscope and a distortion meter to REC OUT of this unit. (See Fig. 2.)
- (4) Make this unit receive at the tuning point where no station is available and adjust the IF primary coil, L104 on the PB-1396 to make the center meter read 0 (zero).
- (5) Make output of the FM signal generator 98MHz, modulation 1KHz and 100% monaural, 60dB.
- (6) Tune this unit at ± 0 on the center meter with the signal specified in the foregoing step (5).
- (7) Adjust the IF secondary coil, L104 on the PB-1396 to make distortion minimum.
- (8) Repeat adjustment as per the foregoing steps, (4)-(7) for a few times and confirm that the specs meet.

3. FM Tracking and Sensitivity Adjustment

- (1) Make output of an FM signal generator 108MHz, 6 dB and set the dial pointer at 108MHz on the dial scale by the tuning knob. Adjust the local oscillator trimmer capacitor, TC5 and the trimmer capacitor for sensitivity adjustment, TC3 and TC4 to make output maximum.
- (2) Set the unit at 88MHz on the dial scale and activate the FM signal generator to make the center meter read 0 (zero).

4. FM Signal Strength Adjustment

- (1) Make output of an FM signal generator 98MHz, 60dB and tune this unit at ± 0 on the center meter.
- (2) Adjust the semi-fixed resistor, VR102 on the PB-1396 to make all of 5 signal strength L.E.D.'s light up.

5. FM MPX and Muting Adjustment

- (1) Connect a frequency counter to the terminal No. 11 on the PB-1396.
- (2) Make output of an FM signal generator 60dB, modulation 0 (zero).
- (3) Put off the mono switch.
- (4) Adjust the semi-fixed resistor, VR104 on the PB-1396 to make frequency 19KHz \pm 0-10Hz.
- (5) Make output of the FM signal generator 12dB, modulation 1KHz 100% monaural.
- (6) Turn the semi-fixed resistor, VR101 on the PB-1396 to the endmost of the counter-clockwise position to confirm that no signal appears and then, turn the semi-fixed resistor, VR101 clockwise and adjust it to make signal come out.
- (7) Put on the mono switch.
- (8) Make output of the FM signal generator 60dB.
- (9) Confirm that the center meter read 0 (zero) and if it is slipped out, adjust the IF primary coil, L104 on the PB-1396.
- (10) Make output of the FM signal generator 60dB.
- (11) Confirm that distortion is minimum. If it is slipped out, adjust the IF secondary coil, L104 on the PB-1396.
- (12) Confirm the foregoing steps (9)-(13) and repeat adjustment unless those would not meet rated specs.
- (13) Make the FM signal generator at stereo modulation.
- (14) Put off the mono switch.
- (15) Adjust the semi-fixed resistor, VR103 on the PB-1396 to make stereo separation both at right and left channels well balanced.
- (16) Adjust the IF coil of the frontend, T1 to make stereo distortion minimum.
- (17) Confirm the steps (6)-(16) and repeat adjustment unless those would not meet rated steps.

EXPLODED VIEW R-5030

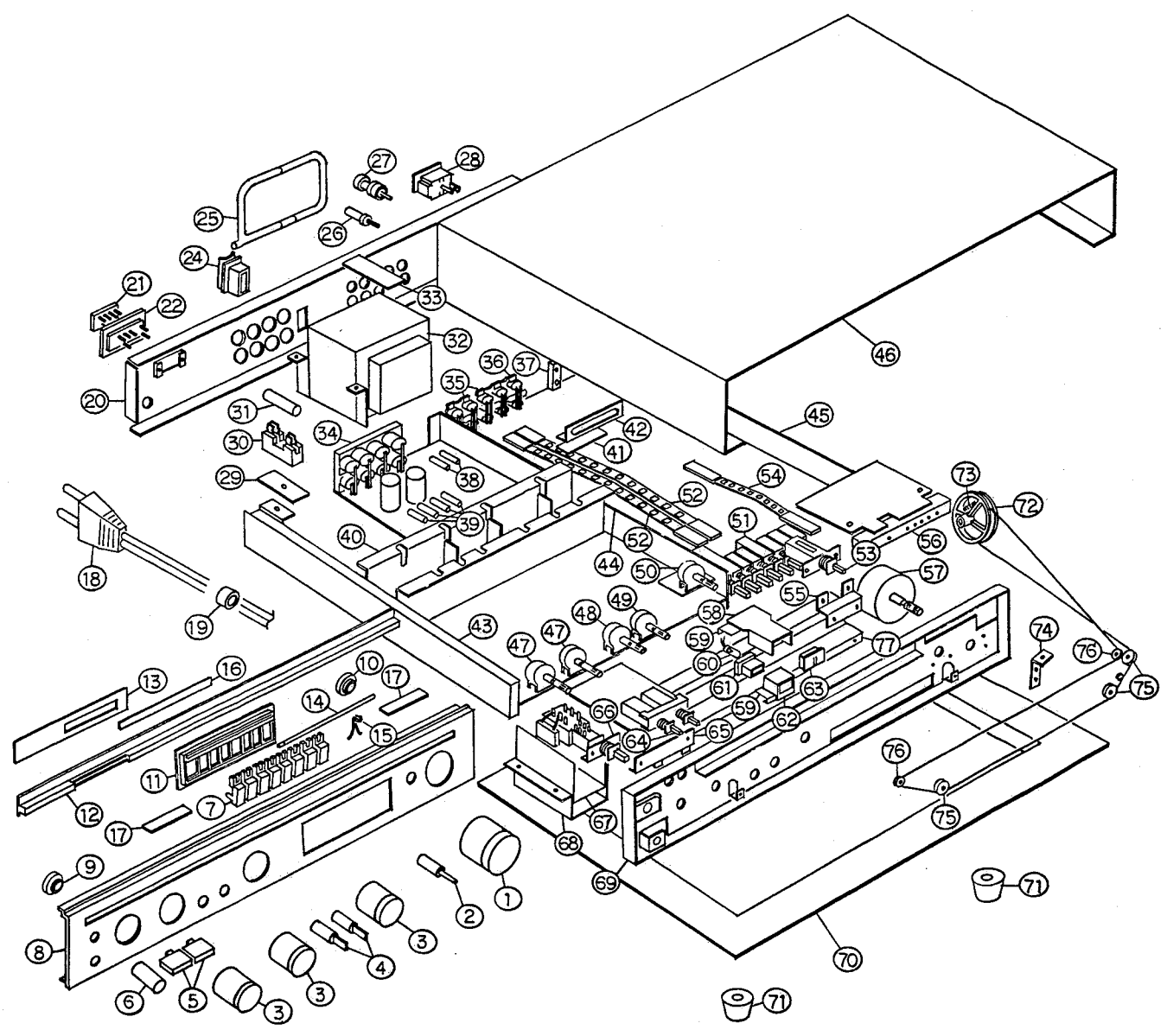

Exploded View Parts List

Remarks:

- U: 120V for North America (With C.A.T. Switch)
 S — SK: 220V for Europe, South-East Asia
 SD: 220V for West Germany
 SG: 240V for England, Australia
 E — EK: 220V (With Line Voltage Selector) for South-East Asia, Europe
 EG: 240V (With Line Voltage Selector) for England, Australia
 EZ: 120V (With Line Voltage Selector) for South-East Asia, Middle-East Asia

Symbol No.	Stock No.	Description	Symbol No.	Stock No.	Description
1	36R51142F02-0	Knob, Control	35	09T51123F01-0	Phono, Plate
2	36R43798U02-A	Knob, Memory (U)	36	09T51123F02-0	Phono, Plate 2P
3	36R51143F01-0	Knob, Control	37	09T51122F01-0	Terminal, ANT
4	36B51053F01-A	Knob, Rotary VR.		09T52574F01	Terminal, ANT 2P (SD)
5	36B51051F03-A	Knob, Push 17	38	65T42077U14-0	Fuse, 0.63AT (S)
6	36R51144F01-0	Knob, Power SW		65T52486F18-0	Fuse 2A (E, U)
7	36B51517F01-A	Knob, 1167	39	65T42077U18	Fuse, 1.6AT (S)
8	64D51137F02-A	Panel, Front		65T52486F19-0	Fuse, 2.5A (E, U)
	64D51137F03-0	Panel, Front (U)	40	07C51055F01-B	Heat Sink
9	07R47364F01-0	Knob, Power 1089	41	43A52566F01-0	Spacer, 1165
10	07R51137F01-0	Frame, Knob (U)	42	07A51524F01-0	Bkt., Wire
11	07C51532F01-C	Frame, Knob	43	07C51057F01-A	Bkt., L
12	34B51531F01-A	Dial, Scale	44	05C51058F01-A	Bkt., C
13	15A51518F01-A	Cover, 1194	45	07C51059F02-0	Bkt., R
14	47A51682F01-0	Shaft, Knob	46	15D51063F01-A	Cover, Top
15	41A51799F01-A	Spring, Knob	47	18T51112F01-0	VR, Rotary 50KCx2
16	43A52336F01-0	Spacer, 1160	48	18T51111F01-0	VR, Rotary 250KMN
17		Non Use	49	18T51109F01-0	VR, Rotary 100KAx2
18	28T43812P02-A	Plug, AC Cord (SK, EK, SD)	50	18T51110F01-0	VR, Rotary 100KBx2
	28T55003F01	Plug, AC Cord (SG, EG)	51	40T51535F01-0	SW, Push SUFR8P
	28T40916U01-0	Plug, AC Cord (EZ, U)	52	45T51965F01-A	Wire, Flex SWR1234
19	43B41625J02-0	Support, Cord	53	40T51536F01-0	SW, Push SUFR1P (U)
	43B41625J04	Support, Cord (SG, EG)	54	45T52098F01-A	Wire, Flex SWR1144 (U)
20	15D51060F05	Cover, Rear (SD)	55	07A51526F01-0	Bkt., SW (U)
	15D51060F06-B	Cover, Rear (SK, SG)	56	15A51519F01-C	Cover, LED
	15D51060F07	Cover, Rear (E)	57	49A51521F01-A	Wheel, 1017
	15D51060F08-B	Cover, Rear (U)	58	07A51851F01-0	Bkt., Scale
21	09T51830F01	Plug, SW P2120 (E)	59	43A51523F01-B	Spacer, 1303
22	09T51831F01	Socket, SW M1615 (E)	60	65T51537F01-A	Lamp, Pilot 12V75mA
23	15A51044F01-0	Cover, 1101 (E)	61	43A51529F01-D	Bushing, Rubber
24	55T51079F01-A	Lock, ANT Holder	62	07A51527F01-C	Frame, 1301
25	85T51078F01-0	Antenna, Loop	63	34A51528F01-B	Indicator, Scale
26	09T51075F01-0	Terminal, GND	64	40T51534F01-0	SW, Push SUL2
27	28T51067F01-0	Plug, Short Phono	65	07A51525F01-A	Bkt., SW
28	09T51080F01-0	Connector, ANT (SK, SG)	66	40T51072F01-0	SW, Power SDU4PS(E, S)
	09T52560F01	Plug, ANT P2132A (SD)		40T52994F01-0	SW, Power (U)
29	43A51453F01-0	Spacer, Fuse	67	14A51034F01-A	Indicator, Power SW
30	09T51074F01-0	Holder, Fuse (S)	68	26A51041F01-A	Shield, SW
	09T51828F01-0	Holder, Fuse (E,U)	69	27D51533F01-C	Chassis, Front
31	65T42077U18	Fuse 1.6AT (S)	70	15D51062F01-C	Cover, Bottom
	65T52486F18	Fuse 2A (EK, EG)	71	75A43532P01-A	Pad, Trannleg
	65T52486F22-0	Fuse 3.5A (EZ, U)	72	49A51551F01-0	Drum, Dial
32	25T51073F01-0	Trans, Power (S)	73	41A51552F01-0	Spring, Drum
	25T51829F01	Trans, Power (E)	74	07A51522F01-A	Bkt., Pulley
	25T52990F01-0	Trans, Power (U)	75	49A51550F01-0	Pulley, 13
33	43A51798F01-0	Spacer, 1154	76	49A51576F01-A	Pulley, 75
34	09T51101F01-0	Terminal, SP	77	07B51530F01-B	Bkt., Dial

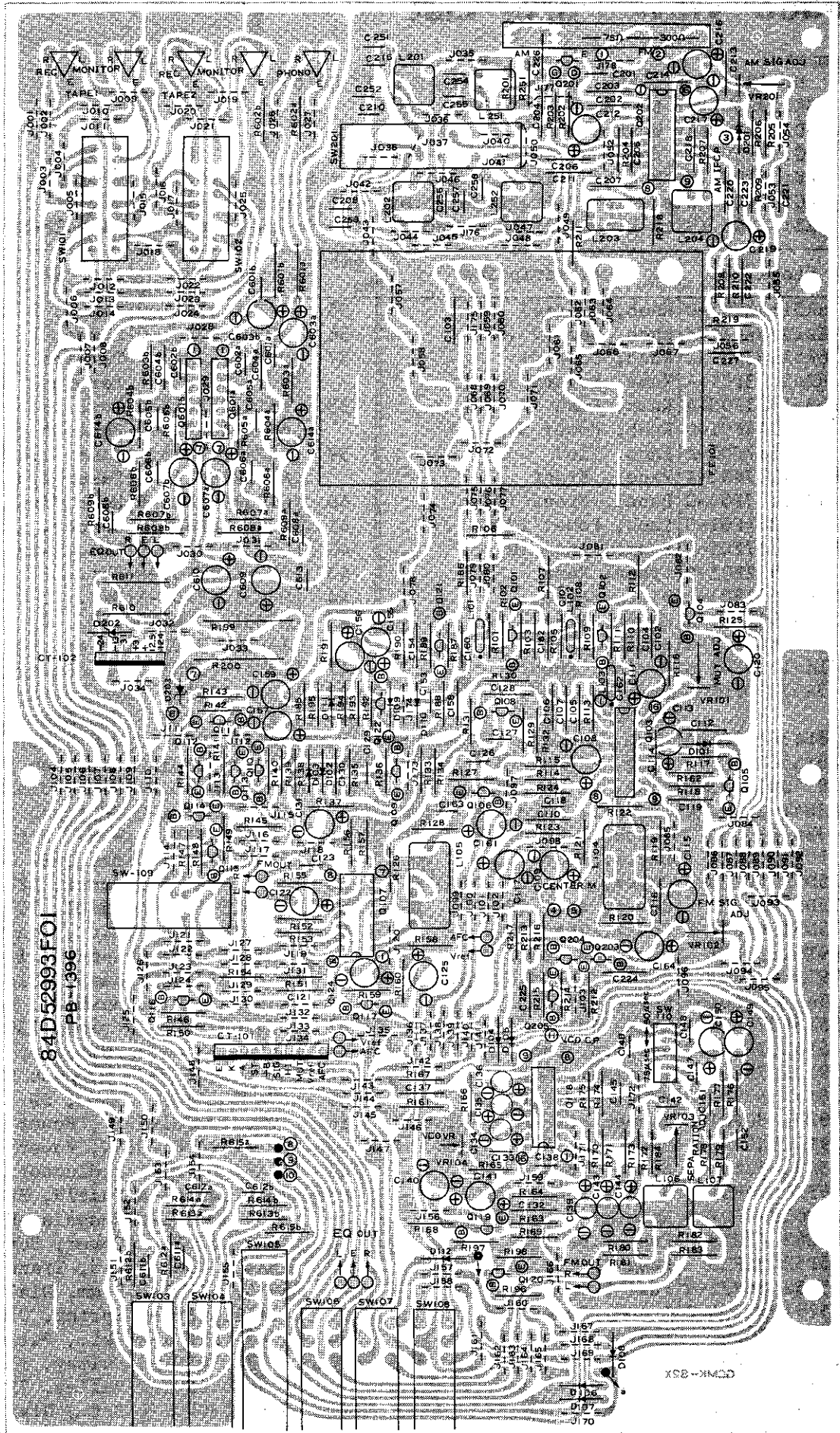

PB-1396 Parts List

Symbol No.	Stock No.	Description	Symbol No.	Stock No.	Description
(Transistor & IC)			(Semi-Fixed Resistor)		
Q101	48T47524F01	Tr, 2SC1923	L203	24T51126F01-0	Trans, IF (450KHz)
Q102	48T47524F01	Tr, 2SC1923	L204	24T51543F01-0	Trans, AM LA-1100
Q103	51T51095F01-0	IC, LA1235	(Switch)		
Q104	48T43525F02	Tr, 2SC1815Y	VR101	18C42061J22-A	20KB
Q105	48T43525F02	Tr, 2SC1815Y	VR102	18C42061J14-0	10KB
Q106	48T43525F02	Tr, 2SC1815Y (U)	VR103	18C42061J17-B	200KB
Q107	51T51696F01-0	IC, TC4016BP (U)	VR104	18C41732G03-L	4.7KB
Q108	48T43525F02	Tr, 2SC1815Y (U)	VR201	18C42061J14-0	10KB
Q109	48T43525F02	Tr, 2SC1815Y (U)	(Frontend)		
Q110	48T51118F01	Tr, 2SA1015Y (U)	SW101	40T51964F01-0	SW, Slide
Q111	48T51118F01	Tr, 2SA1015Y (U)	SW102	40T51964F01-0	SW, Slide *
Q112	48T43525F02	Tr, 2SC1815Y (U)	SW103~108	40T51535F01-0	SW, Push SUFR8P
Q113	48T43525F02	Tr, 2SC1815Y (U)	SW109	40T52097F01-0	SW, Slide SSR22352D (U)
Q114	48T51118F01	Tr, 2SA1015Y (U)	(Resistor)		
Q115	48T43525F02	Tr, 2SC1815Y (U)	FE101	77T51544F01-0	FF212U81
Q116	48T43525F02	Tr, 2SC1815Y (U)	R101	06S44593P57	470 1/4WV Rd
Q117	48T43525F02	Tr, 2SC1815Y	R102	06S44593P75	2.7K 1/4WV Rd
Q118	51T51094F01-0	IC, uPC1235C	R103	06S44593P41	100 1/4WV Rd
Q119	48T43525F02	Tr, 2SC1815Y	R104	06S44593P41	100 1/4WV Rd (U)
Q120	48T43525F02	Tr, 2SC1815Y	R105	06S44593P53	330 1/4WV Rd
Q121	48T47524F01	Tr, 2SC1923	R106	06S44593P41	100 1/4WV Rd
Q122	48T43525F02	Tr, 2SC1815Y	R107	06S44593P41	100 1/4WV Rd
Q202	51T51096F01-0	IC, LA1240	R108	06S44593P57	470 1/4WV Rd
Q203	48T43525F02	Tr, 2SC1815Y	R109	06S44593P75	2.7K 1/4WV Rd
Q204	48T43525F02	Tr, 2SC1815Y	R110	06S44593P57	470 1/4WV Rd
Q205	48T51118F01	Tr, 2SA1015Y	R111	06S44593P53	330 1/4WV Rd
Q601a,b	51T51093F01-0	IC, M5213L	R112	06S44593P41	100 1/4WV Rd
(Diode)			R113	06S44593P53	330 1/4WV Rd
D101	48T51087F01	KB265C4 Varistor	R114	06S44594P06	47K 1/4WV Rd
D102	48B41768G01	1N60 Silicon	R115	06S44593P89	10K 1/4WV Rd
D103	48B41768G01	1N60 Silicon	R116	06S44594P12	82K 1/4WV Rd
D104	48T51881F01	DS442-BT Silicon	R117	06S44594P06	47K 1/4WV Rd
D105	48T51881F01	DS442-BT Silicon	R118	06S44593P33	47 1/4WV Rd
D106	48T51881F01	DS442-BT Silicon	R119	06S44593P83	5.6K 1/4WV Rd
D107	48T51881F01	DS442-BT Silicon	R120	06S44593P73	2.2K 1/4WV Rd
D108	48T51881F01	DS442-BT Silicon	R121	06S44593P99	27K 1/4WV Rd
D109	48B41768G01	1N60 Silicon	R122	06S44593P49	220 1/4WV Rd
D110	48B41768G01	1N60 Silicon	R123	06S44593P83	5.6K 1/4WV Rd
D111	48T41768G01	1N60 Silicon	R124	06S44593P49	220 1/4WV Rd (U)
D112	48T51881F01	DS442-BT Silicon	R125	06S44593P81	4.7K 1/4WV Rd
D201	48T51087F01	KB265C4 Varistor	R126	06S44593P89	10K 1/4WV Rd (U)
D202	48T40150U65	HZ12B-2 Zener	R127	06S44593P81	4.7K 1/4WV Rd (U)
(Coil)			R128	06S44593P89	10K 1/4WV Rd
L101	91T51130F01-0	Filter, Ser. SFE10.7MM	R129	06S44593P65	1K 1/4WV Rd
L102	91T51130F01-0	Filter, Ser. SFE10.7MM	R130	06S44593P97	22K 1/4WV Rd (U)
L103	91T51131F01-0	Filter, Ser. SFE10.7ML	R131	06S44593P97	22K 1/4WV Rd (U)
L104	24T51128F01-0	Trans, FM DET	R132	06S44593P73	2.2K 1/4WV Rd (U)
L105	91T51083F01-0	Filter, Anti Birdy	R133	06S44593P71	1.8K 1/4WV Rd (U)
L106	91T51124F01-0	Filter, MPX	R134	06S44593P87	8.2K 1/4WV Rd (U)
L107	91T51124F01-0	Filter, MPX	R135	06S44593P65	1K 1/4WV Rd (U)
L201	24T51125F01-0	Trans, ANT. (AM)	R136	06S44593P77	3.3K 1/4WV Rd (U)
L202	24T51542F01-0	Trans, AM LUX-1073			

Symbol No.	Stock No.	Description	Symbol No.	Stock No.	Description
R137	06S44594P14	100K 1/4WV Rd (U)	R197	06S44593P91	12K 1/4WV Rd
R138	06S44593P89	10K 1/4WV Rd (U)	R198	06S44594P22	220K 1/4WV Rd
R139	06S44593P81	4.7K 1/4WV Rd (U)	R199	06T51108F12	680 2WV Rm
R140	06S44594P06	47K 1/4WV Rd (U)	R200	06T51108F23	560 2WV Rm
R141	06S44593P97	22K 1/4WV Rd (U)	R201	06S44593P49	220 1/4WV Rd
R142	06S44593P97	22K 1/4WV Rd (U)	R204	06S44593P69	1.5K 1/4WV Rd
R143	06S44594P06	47K 1/4WV Rd (U)	R205	06S44593P89	10K 1/4WV Rd
R144	06S44593P97	22K 1/4WV Rd (U)	R206	06S44593P89	10K 1/4WV Rd
R145	06S44594P06	47K 1/4WV Rd (U)	R207	06S44593P53	330 1/4WV Rd
R146	06S44594P06	47K 1/4WV Rd (U)	R208	06S44593P41	100 1/4WV Rd
R147	06S44593P89	10K 1/4WV Rd (U)	R209	06S44593P77	3.3K 1/4WV Rd
R148	06S44593P97	22K 1/4WV Rd (U)	R210	06S44593P81	4.7K 1/4WV Rd
R149	06S44593P89	10K 1/4WV Rd (U)	R211	06S44593P49	220 1/4WV Rd
R150	06S44593P67	1.2K 1/4WV Rd (U)	R212	06S44593P85	6.8K 1/4WV Rd
R151	06S44594P06	47K 1/4WV Rd (U)	R213	06S44594P10	68K 1/4WV Rd
R152	06S44594P18	150K 1/4WV Rd (U)	R214	06S44593P41	100 1/4WV Rd
R153	06S44593P89	10K 1/4WV Rd (U)	R215	06S44594P14	100K 1/4WV Rd
R154	06S44594P24	270K 1/4WV Rd (U)	R216	06S44593P79	3.9K 1/4WV Rd
R155	06S44594P14	100K 1/4WV Rd (U)	R217	06S44593P81	4.7K 1/4WV Rd
R156	06S44594P14	100K 1/4WV Rd (U)	R218	06S44593P83	5.6K 1/4WV Rd
R157	06S44593P89	10K 1/4WV Rd (U)	R219	06S44593P65	1K 1/4WV Rd
R158	06S44593P89	10K 1/4WV Rd	R601a,b	06D40801G75	3.3K 1/2WV Rd
R159	06S44593P49	220 1/4WV Rd	R602a,b	06S44594P10	68K 1/4WV Rd
R160	06S44593P77	3.3K 1/4WV Rd	R603a,b	06S44594P22	220K 1/4WV Rd
R161	06S44594P06	47K 1/4WV Rd	R604a,b	06S44594P53	330 1/4WV Rd
R162	06S44593P93	15K 1/4WV Rd	R605a,b	06S44594P22	220K 1/4WV Rd
R163	06S44593P89	10K 1/4WV Rd	R606a,b	06S44593P95	18K 1/4WV Rd
R164	06S44594P14	100K 1/4WV Rd	R607a,b	06S44593P57	470 1/4WV Rd
R165	06S44593P93	15K 1/4WV Rd	R608a,b	06D40801G63	1K 1/2WV Rd
R166	06S44593P65	1K 1/4WV Rd	R609a,b	06S44594P22	220K 1/4WV Rd
R167	06S44593P67	1.2K 1/4WV Rd	R610	06T51108F17	680 1/2WV Rd
R168	06S44593P77	3.3K 1/4WV Rd	R611	06T51108F17	680 1/2WV Rd
R169	06S44593P97	22K 1/4WV Rd	R612a,b	06S44594P38	1M 1/4WV Rd
R170	06S44593P97	22K 1/4WV Rd	R613a,b	06 44593P77	3.3K 1/4WV Rd
R171	06S44593P97	22K 1/4WV Rd	R614a,b	06S44594P38	1M 1/4WV Rd
R172	06S44593P83	5.6K 1/4WV Rd	R615a,b	06S44593P85	6.8K 1/4WV Rd
R173	06S44593P83	5.6K 1/4WV Rd	(Capacitor)		
R174	06S44594P06	47K 1/4WV Rd	C101	08S44505P63	0.022µF 16WV Ce
R175	06S44594P06	47K 1/4WV Rd	C102	08S44505P63	0.022µF 16WV Ce
R176	06S44593P67	1.2K 1/4WV Rd	C103	08S44505P63	0.022µF 16WV Ce
R177	06S44593P67	1.2K 1/4WV Rd	C104	08S44505P63	0.022µF 16WV Ce
R178	06S44593P65	1K 1/4WV Rd	C105	08S44505P63	0.022µF 16WV Ce
R179	06S44593P65	1K 1/4WV Rd	C106	08S44505P63	0.022µF 16WV Ce
R180	06S44593P81	4.7K 1/4WV Rd	C107	08S44505P63	0.022µF 16WV Ce
R181	06S44593P49	220 1/4WV Rd	C108	23T51235F16	10µF 16WV E1
R182	06S44593P81	4.7K 1/4WV Rd	C109	23T51235F01	0.47µF 50WV E1
R183	06S44593P49	220 1/4WV Rd	C110	08S44505P63	0.022µF 16WV Ce
R184	06S44593P41	100 1/4WV Rd	C111	23T51235F01	0.47µF 50WV E1
R185	06S44594P02	33K 1/4WV Rd	C112	08S44505P63	0.022µF 16WV Ce
R186	06S44593P65	1K 1/4WV Rd	C113	23T51235F01	0.47µF 50WV E1
R187	06S44594P26	330K 1/4WV Rd	C114	08S44505P63	0.022µF 16WV Ce
R188	06S44593P77	3.3K 1/4WV Rd	C115	23T51235F44	100µF 16WV E1
R189	06S44594P14	100K 1/4WV Rd	C116	08S44505P63	0.022µF 16WV Ce
R190	06S44593P75	2.7K 1/4WV Rd	C117	23T51235F08	3.3µF 50WV E1
R191	06S44594P06	47K 1/4WV Rd	C118	21S40655F23	100pF 50WV Ce
R192	06S44594P30	470K 1/4WV Rd	C119	08S44505P63	0.022µF 16WV Ce
R193	06S44593P77	3.3K 1/4WV Rd	C120	23T51235F01	0.47µF 50WV E1
R194	06S44594P14	100K 1/4WV Rd	C121	23T51235F16	10µF 16WV E1 (U)
R195	06S44594P02	33K 1/4WV Rd	C122	23T51235F03	1µF 50WV E1 (U)
R196	06S44593P97	22K 1/4WV Rd	C123	08S40856F21	0.047µF 50WV My (U)

Symbol No.	Stock No.	Description	Symbol No.	Stock No.	Description
C124	23T51235F24	22 μ F 16WV E1	C160	08S44505P63	0.022 μ F 16WV Ce
C125	23T51235F16	10 μ F 16WV E1	C161	23T51235F44	100 μ F 16WV E1
C126	08T42081U15	390pF PP (U)	C162	08S44505P63	0.022 μ F 16WV Ce
C127	08T42081U15	390pF PP (U)	C202	08S44505P63	0.022 μ F 16WV Ce
C128	08S44505P49	1000pF 50WV Ce (U)	C203	08S44505P63	0.022 μ F 16WV Ce
C129	21C45322G33	0.047 μ F 25WV Ce (U)	C205	08S44505P63	0.022 μ F 16WV Ce
C130	08S44505P61	0.01 μ F 25WV Ce (U)	C206	08S44505P63	0.022 μ F 16WV Ce
C131	23T51235F01	0.47 μ F 50WV E1 (U)	C207	08S44505P63	0.022 μ F 16WV Ce
C132	08S44505P63	0.022 μ F 16WV Ce	C210	21S40655F13	15pF Ce
C133	08T44481F05	470pF PP	C211	08S44505P63	0.022 μ F 16WV Ce
C134	23T51235F03	1 μ F 50WV E1	C212	23T51235F38	47 μ F 16WV E1
C135	23T51234F07	3.3 μ F 50WV E1	C213	08S44505P63	0.022 μ F 16WV Ce
C136	23T51236F02	0.22 μ F 50WV E1 LR	C214	08S44505P63	0.022 μ F 16WV Ce
C137	08S44505P63	0.022 μ F 16WV Ce	C215	21S40655F06	5pF 50WV Ce
C138	08S40656F21	0.047 μ F 50WV My	C216	23T51235F16	10 μ F 16WV E1
C139	23T51235F16	10 μ F 16WV E1	C217	23T51235F13	4.7 μ F 50WV E1
C140	23T51235F16	10 μ F 16WV E1	C218	08S44505P49	1000pF 50WV Ce
C141	23T51235F38	47 μ F 16WV E1	C219	23T51235F38	47 μ F 16WV E1
C142	08T42081U19	100pF PP	C221	08S44505P63	0.022 μ F 16WV Ce
C142	08T42081U03	120pF PP (U)	C212	23T51236F02	0.22 μ F 50WV E1 LR
C143	23T51234F14	10 μ F 16WV E1	C213	08S44505P63	0.022 μ F 16WV Ce
C144	23T51235F16	10 μ F 16WV E1	C214	08S44505P61	0.01 μ F 25WV Ce
C145	08S40656F01	1000pF My	C215	08S44505P61	0.01 μ F 25WV Ce
C145	08S40656F03	1500pF My (U)	C216	08S44505P63	0.022 μ F 16WV Ce
C146	08S40656F01	1000pF My	C217	08S44505P63	0.022 μ F 16WV Ce
C146	08S40656F03	1500pF My (U)	C601a,b	21S40655F30	470pF 50WV Ce
C147	21S40655F32	680pF Ce	C602a,b	21S40655F19	47pF Ce
C148	21S40655F32	680pF Ce	C603a,b	23T51236F06	2.2 μ F 50WV E1 LR
C149	23T51235F05	2.2 μ F 50WV E1	C604a,b	08S44505P49	1000pF 50WV Ce
C150	23T51234F05	2.2 μ F 50WV E1	C605a,b	08S40656F14	0.012 μ F 50WV My
C151	08S40656F11	6800pF 50WV My	C606	08S40656F08	3900pF 50WV My
C152	08S40656F11	6800pF 50WV My	C607	23T51236F05	1 μ F 50WV E1 LR
C153	21S40655F23	100pF 50WV Ce	C608	21S40655F23	100pF 50WV Ce
C154	08S44505P49	1000pF Ce	C609	23T51234F54	220 μ F 25WV E1
C155	23T51235F01	0.47 μ F 50WV E1	C610	23T51234F54	220 μ F 25WV E1
C156	23T51235F03	1 μ F 50WV E1	C611a,b	08S44505P26	0.12 μ F 50WV My
C157	23T51235F16	10 μ F 16WV E1	C612a,b	08S40656F10	5600pF 50WV My
C158	08S44505P63	0.022 μ F 16WV Ce	C613	21C45322G33	0.047 μ F 25WV Ce
C159	23T51235F16	10 μ F 16WV E1	C614a,b	23T51235F24	22 μ F 16WV E1

Remarks:

Capacitor: E1... Electrolytic, Ce... Ceramic, My... Mylar, PP... Polypropylene

Resistor: Rd... Carbon, Rm... Metal Film

(U) : 120V for North America (With C.A.T. Switch)

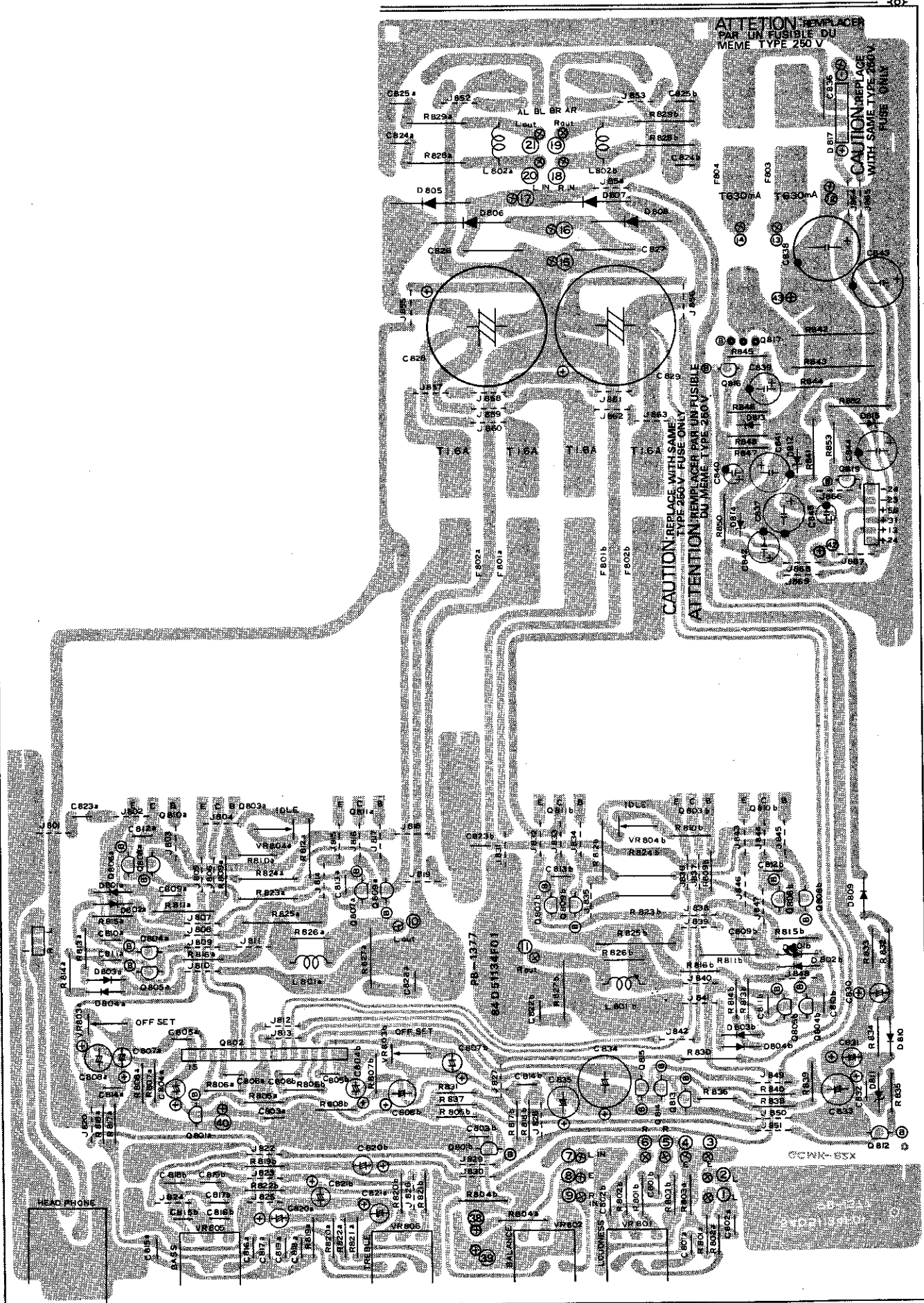

ATTENTION - REMPLACER
PAR UN FUSIBLE DU
MEME TYPE 250 V

CAUTION - REPLACE
WITH SAME TYPE 360V
FUSE ONLY

CAUTION - REPLACE WITH SAME
TYPE 360V FUSE ONLY
ATTENTION - REMPLACER PAR UN FUSIBLE
DU MEME TYPE 360V

GC1NR-55X

PB-1377 Parts List

Symbol No.	Stock No.	Description	Symbol No.	Stock No.	Description
(Transistor & IC)			R811a,b	06T51108F03	33 1/2WV Rm
Q801a,b	48T51118F01	Tr, 2SA1015Y	R812a,b	06T51108F03	33 1/2WV Rm
Q802	51T51114F01-0	IC, STK-3042	R813a,b	06S44593P93	15K 1/4WV Rd
Q803a,b	48T43525F02	Tr, 2SC1815Y	R814a,b	06S44593P93	15K 1/4WV Rd
Q804a,b	48T43525F02	Tr, 2SC1815Y	R815a,b	06S44593P53	330 1/4WV Rd
Q805a,b	48T51118F01	Tr, 2SA1015Y	R816a,b	06S44593P53	330 1/4WV Rd
Q806a,b	48T43525F02	Tr, 2SC1815Y	R817a,b	06S44593P87	8.2K 1/4WV Rd
Q807a,b	48T51118F01	Tr, 2SA1015Y	R818a,b	06S44594P06	47K 1/4WV Rd
Q808a,b	48T51120F01	Tr, 2SC2235Y	R819a,b	06S44593P87	8.2K 1/4WV Rd
Q809a,b	48T51119F01	Tr, 2SA965Y	R820a,b	06S44593P71	1.8K 1/4WV Rd
Q810a,b	48T51071F01	Tr, 2SC2577Y	R821a,b	06S44593P53	330 1/4WV Rd
Q811a,b	48T51070F01	Tr, 2SA1102Y	R822a,b	06S44593P69	1.5K 1/4WV Rd
Q812	48T51121F01	Tr, 2SA992E	R823a,b	06T51108F08	2.2K 1/4WV Rm
Q813	48T51121F01	Tr, 2SA992E	R824a,b	06T51108F05	150 1/2WV Rm
Q814	48T51121F01	Tr, 2SA992E	R825a,b	06T51107F01	0.22 2WV Rc
Q815	48T51119F01	Tr, 2SA965Y	R826a,b	06S44593P17	10 1/4WV Rd
Q816	48T43525F02	Tr, 2SC1815Y	R827a,b	06T51108F02	10 1/2WV Rm
Q817	48T42620F02	Tr, 2SD880Y	R830	06T51108F04	47 1/2WV Rm
(Diode)			R831	06S44594P16	120K 1/4WV Rd
D801a,b	48T51117F01	1S1555 Silicon	R832	06S44593P65	1K 1/4WV Rd
D802a,b	48T51117F01	1S1555 Silicon	R833	06S44593P89	10K 1/4WV Rd
D803a,b	48T51117F01	1S1555 Silicon	R834	06S44594P26	330K 1/4WV Rd
D804a,b	48T51117F01	1S1555 Silicon	R835	06S44594P06	47K 1/4WV Rd
D805	48T51115F01	S3V20 Silicon	R836	06S44593P89	10K 1/4WV Rd
D806	48T51115F01	S3V20 Silicon	R837	06S44593P89	10K 1/4WV Rd
D807	48T51115F01	S3V20 Silicon	R838	06S44593P97	22K 1/4WV Rd
D808	48T51115F01	S3V20 Silicon	R839	06S44594P14	100K 1/4WV Rd
D809	48T40477U01	1N4003 Silicon	R840	06S44593P65	1K 1/4WV Rd
D810	48T40477U01	1N4003 Silicon	R841	06T51108F06	390 1/2WV Rm
D811	48T40150U77	HZ18-2 Zener	R842	06T51108F19	150 2WV Rm
D812	48T40150U86	HZ24-2 Zener	R843	06T51108F19	150 2WV Rm
D813	48T40150U31	HZ6B-1 Zener	R844	06S44593P63	820 1/4WV Rd
D815	48T40150U86	HZ24-2 Zener	R845	06S44593P63	820 1/4WV Rd
D817	48T51116F01	SLVB10 Bridge	R846	06S44593P71	1.8K 1/4WV Rd
(Variable Resistor)			R847	06S44593P89	10K 1/4WV Rd
VR801	18T51109F01-0	100KA x 2 Loudness	R848	06S44593P89	10K 1/4WV Rd
VR802	18T51111F01-0	250KMN x 2 Balance	R852	06T51108F22	270 1/2WV Rm
VR803a,b	18C42061J15-B	50KB Semi-Fixed	R853	06S40150T65	1K 1/4WV Rd
VR804a,b	18C42061J23-A	500B Semi-Fixed	(Capacitor)		
VR805	18T51112F01-0	50KC x 2 Bass	C801a,b	08S40656F04	1800pF 50WV My
VR806	18T51112F01-0	50KC x 2 Treble	C802a,b	08S40656F19	0.033μF 50WV My
(Coil)			C803a,b	21S40655F23	100pF Ce
L801a,b	24T51105F01-0	Coil, Choke	C804a,b	23T51236F04	0.47μF 50WV E1 LR
(Terminal)			C805a,b	21S40655F28	270pF Ce
	09T51101F01-0	Terminal, SP	C806a,b	21S40655F25	150pF Ce
(Jack)			C807a,b	23T51235F03	1μF 50WV E1
	09T51106F01-0	Jack, HP	C808a,b	23T51234F37	47μF 16WV E1
(Resistor)			C809a,b	08S40805F22	0.04μF Ce
R801a,b	06S44593P71	1.8K 1/4WV Rd	C810a,b	21S40655F30	470pF Ce
R802a,b	06S44593P81	4.7K 1/4WV Rd	C811a,b	21S40655F30	470pF Ce
R803a,b	06S44593P83	5.6K 1/4WV Rd	C812a,b	21S40655F20	56pF Ce
R804a,b	06D40801G57	560 1/2WV Rd	C813a,b	21S40655F17	33pF Ce
R805a,b	06S44593P89	10K 1/4WV Rd	C814a,b	08T51104F01	15pF My
R806a,b	06S44593P67	1.2K 1/4WV Rd	C815a,b	08S40656F11	6800pF 50WV My
R807a,b	06S44594P08	56K 1/4WV Rd	C816a,b	08S40656F19	0.033μF 50WV My
R808a,b	06S44593P57	470 1/4WV Rd	C817a,b	08S44503P23	0.068μF 50WV My
R809a,b	06S44593P85	6.8K 1/4WV Rd	C818a,b	08S40656F08	3900pF 50WV My
R810a,b	06S44593P69	1.5K 1/4WV Rd	C819a,b	08S40656F17	0.022μF 50WV My

Symbol No.	Stock No.	Description	Symbol No.	Stock No.	Description
C820a,b	23T51235F13	4.7μF 50WV E1	C834	23T51234F56	220μF 50WV E1
C821a,b	23T51235F24	22μF 16WV E1	C835	23T51235F41	47μF 50WV E1
C822a,b	08S40656F21	0.047μF 50WV My	C836	08T51103F01	0.01μF 500WV Ce
C823a,b	08S40805F22	0.047μF 50WV Ce	C837	23T51234F54	220μF 25WV E1
C826	08T43867F01	0.01μF 250WV Ac	C838	23T51234F79	1000μF 35WV E1
C827	08T43867F01	0.01μF 250WV Ac	C839	23T51235F44	100μF 16WV E1
C828	23T51102F01	6800μF 50WV E1	C840	23T51235F37	47μF 10WV E1
C829	23T51102F01	6800μF 50WV E1	C841	23T51234F53	220μF 16WV E1
C830a,b	23T51235F19	10μF 50WV E1	C842	23T51235F47	220μF 10WV E1
C831	23T51235F19	10μF 50WV E1	C843	23T51234F71	470μF 35WV E1
C832	21C45322G31	0.01μF Ce	C844	23T51234F54	220μF 25WV E1
C833	23T51235F13	4.7μF 50WV E1	C845	23T51235F25	22μF 16WV E1

PB-1397 Parts List

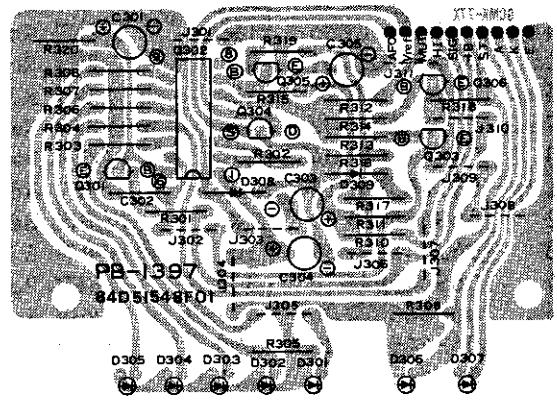

Symbol No.	Stock No.	Description
(Transistor & IC & FET)		
Q301	48T43525F02	Tr, 2SC1815Y
Q302	51T51541F01-0	IC, BA685
Q303	48T43525F02	Tr, 2SC1815Y
Q304	48T51539F01	FET, 2SK117Y
Q305	48T43525F02	Tr, 2SC1815Y
Q306	48T43525F02	Tr, 2SC1815Y
(Resistor)		
R301	06344594P04	39K 1/4WV Rd
R302	06S44593P57	470 1/4WV Rd
R303	06S44593P67	1.2K 1/4WV Rd
R304	06S44593P67	1.2K 1/4WV Rd
R305	06S44594P06	47K 1/4WV Rd (U)
R306	06S44593P67	1.2K 1/4WV Rd
R307	06S44593P67	1.2K 1/4WV Rd
R308	06S44593P67	1.2K 1/4WV Rd
R309	06S44593P89	10K 1/4WV Rd
R310	06S44593P81	4.7K 1/4WV Rd
R311	06S44594P06	47K 1/4WV Rd
R312	06S44593P81	4.7K 1/4WV Rd
R313	06S44594P06	47K 1/4WV Rd
R314	06S44594P06	47K 1/4WV Rd
R315	06S44594P06	47K 1/4WV Rd
R316	06S44594P30	470K 1/4WV Rd
R317	06S44594P06	47K 1/4WV Rd
R318	06S44593P89	10K 1/4WV Rd
R319	06S44594P06	47K 1/4WV Rd
R320	06S44594P06	47K 1/4WV Rd

Symbol No.	Stock No.	Description
(Diode & LED)		
D301	48T51540F01	LN26RP (red) LED
D302	48T51540F01	LN26RP (red) LED
D303	48T51540F01	LN26RP (red) LED
D304	48T51540F01	LN26RP (red) LED
D305	48T51540F01	LN26RP (red) LED
D306	48T51540F01	LN26RP (red) LED
D307	48T51540F01	LN26RP (red) LED (U)
D308	48T51881F01	DS442-BT Silicon
D309	48T51881F01	DS442-BT Silicon
(Capacitor)		
C301	23T51235F03	1μF 50WV E1
C302	08S44505P63	0.022μF 16WV Ce
C303	23T51235F08	3.3μF 50WV E1
C304	23T51235F31	33μF 16WV E1
C305	23T51235F08	3.3μF 50WV E1

PB-1378-1 Parts List

Symbol No.	Stock No.	Description
(Switch)		
SW704,5	40T51534F04-0	SW., Push SUL2
(Resistor)		
R705a,b	06T51108F11	220 2WV Rm

PB-1391 Parts List

Symbol No.	Stock No.	Description
(Variable Resistor)		
VR901	18T51110F01-0	100KB x 2 Volume

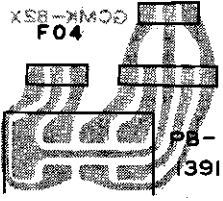
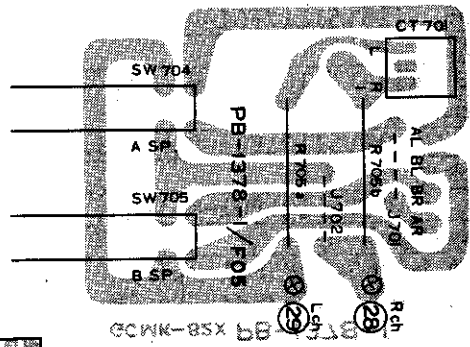

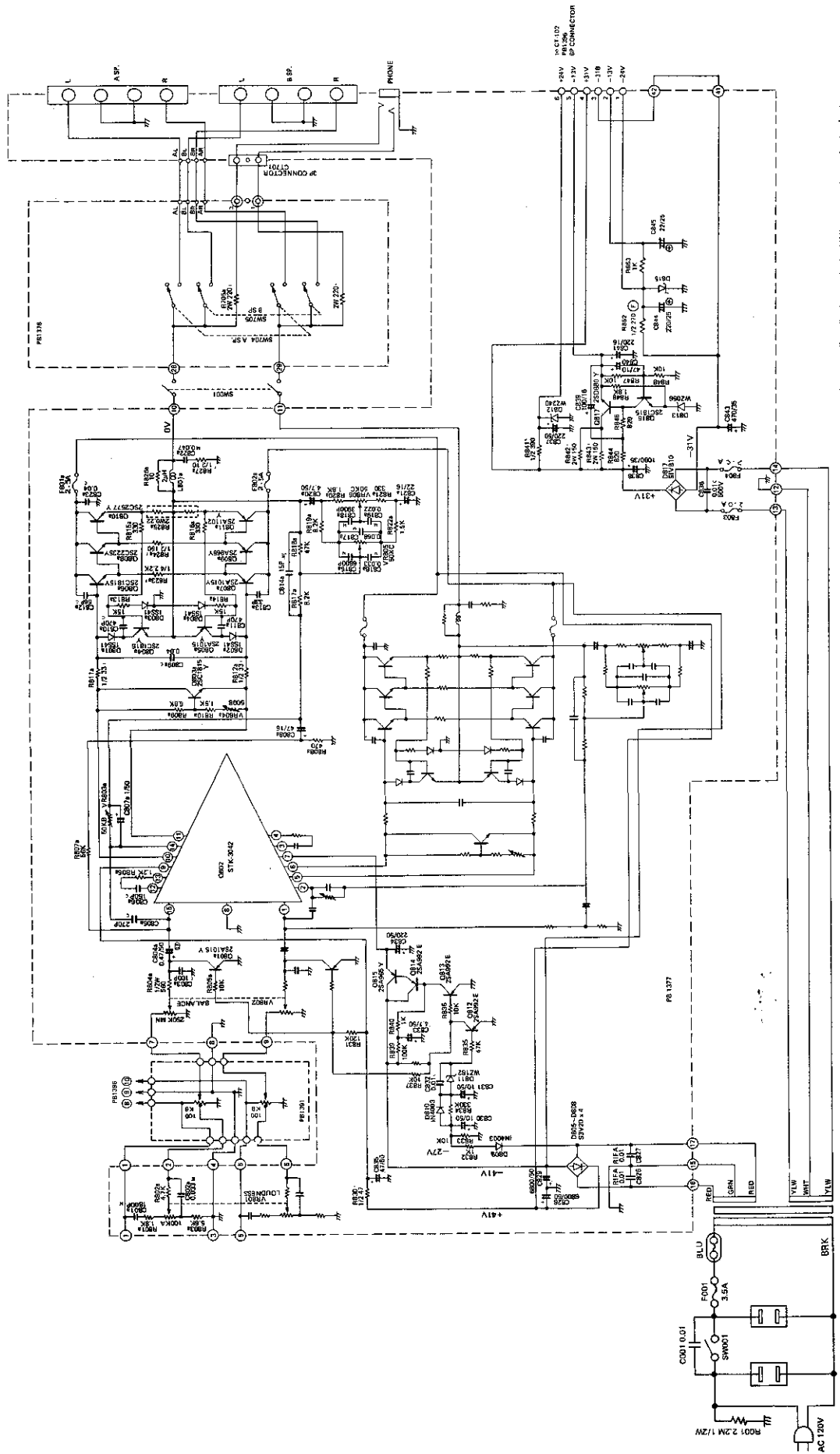

1. Unless otherwise specified, all resistors are in ohms. 1/4 Watt, all capacitors are in micro farads.
2. Transistors and diodes are in the same order as they appear in the schematic.
3. Data for component manufacturers, LUSMAN received through to after the circuit or specification.

R-5030 AUDIO SECTION With C.A.T. Switch

52590F01

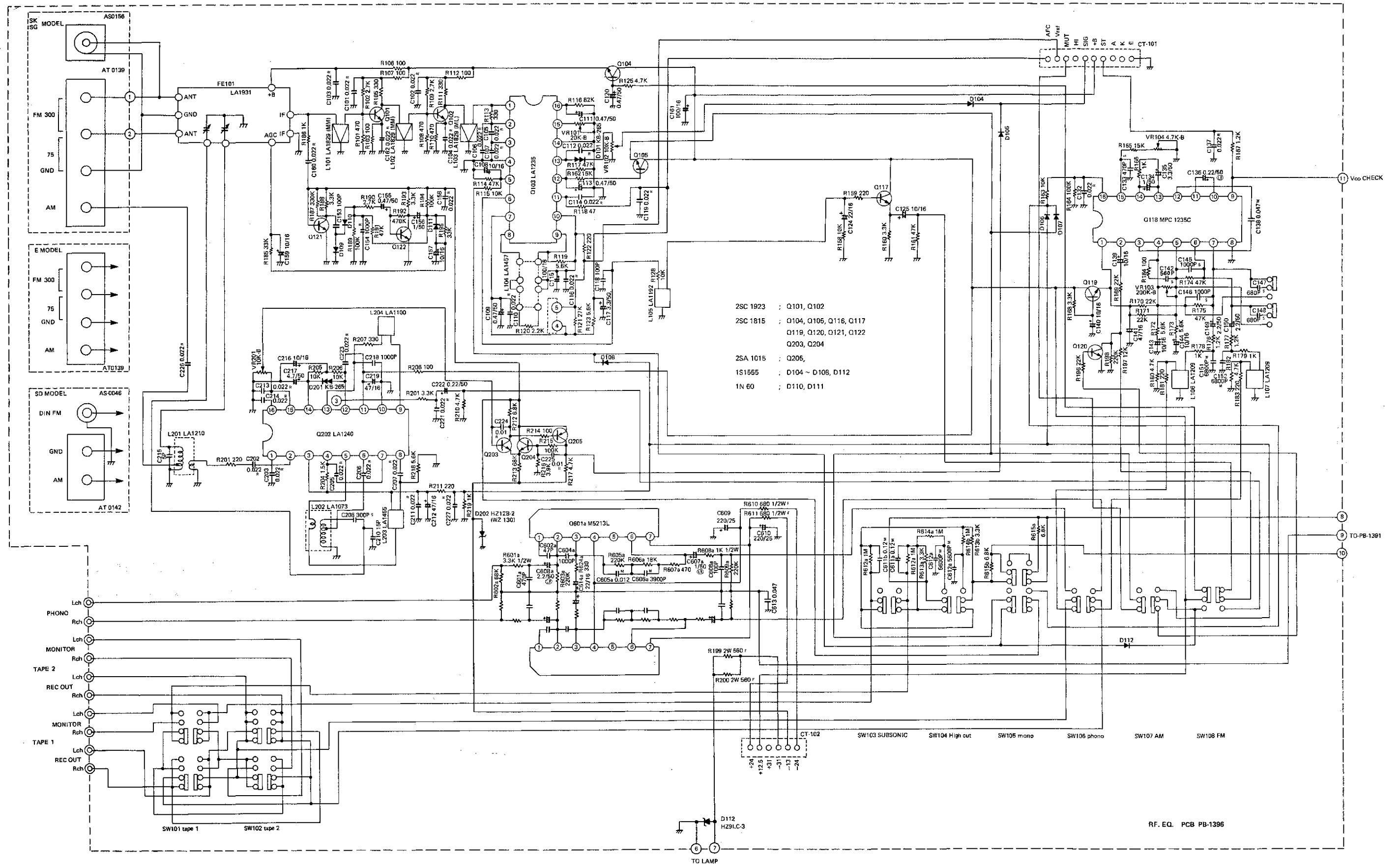

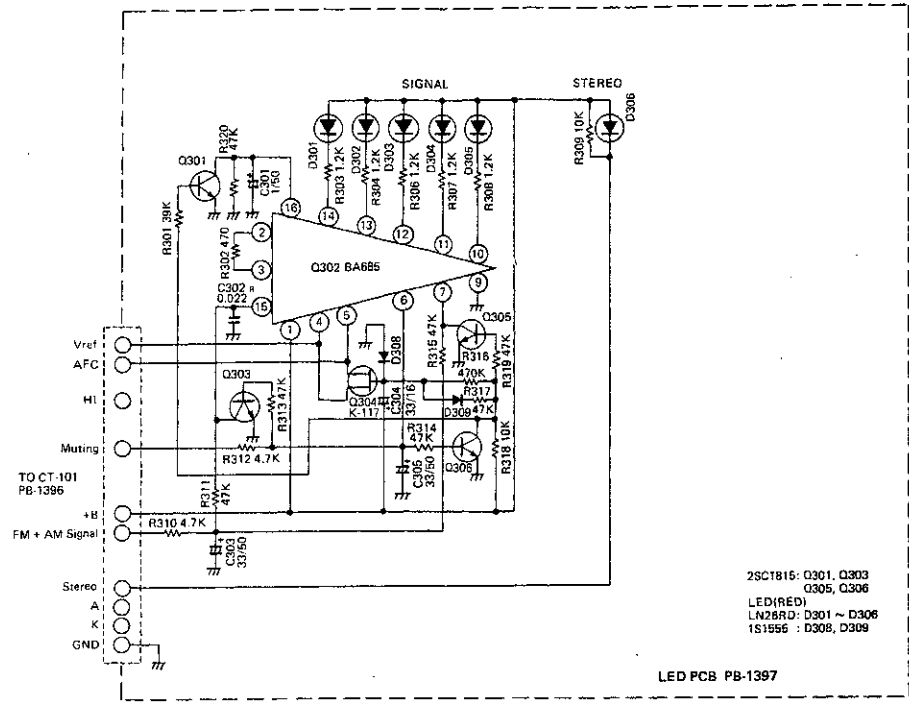
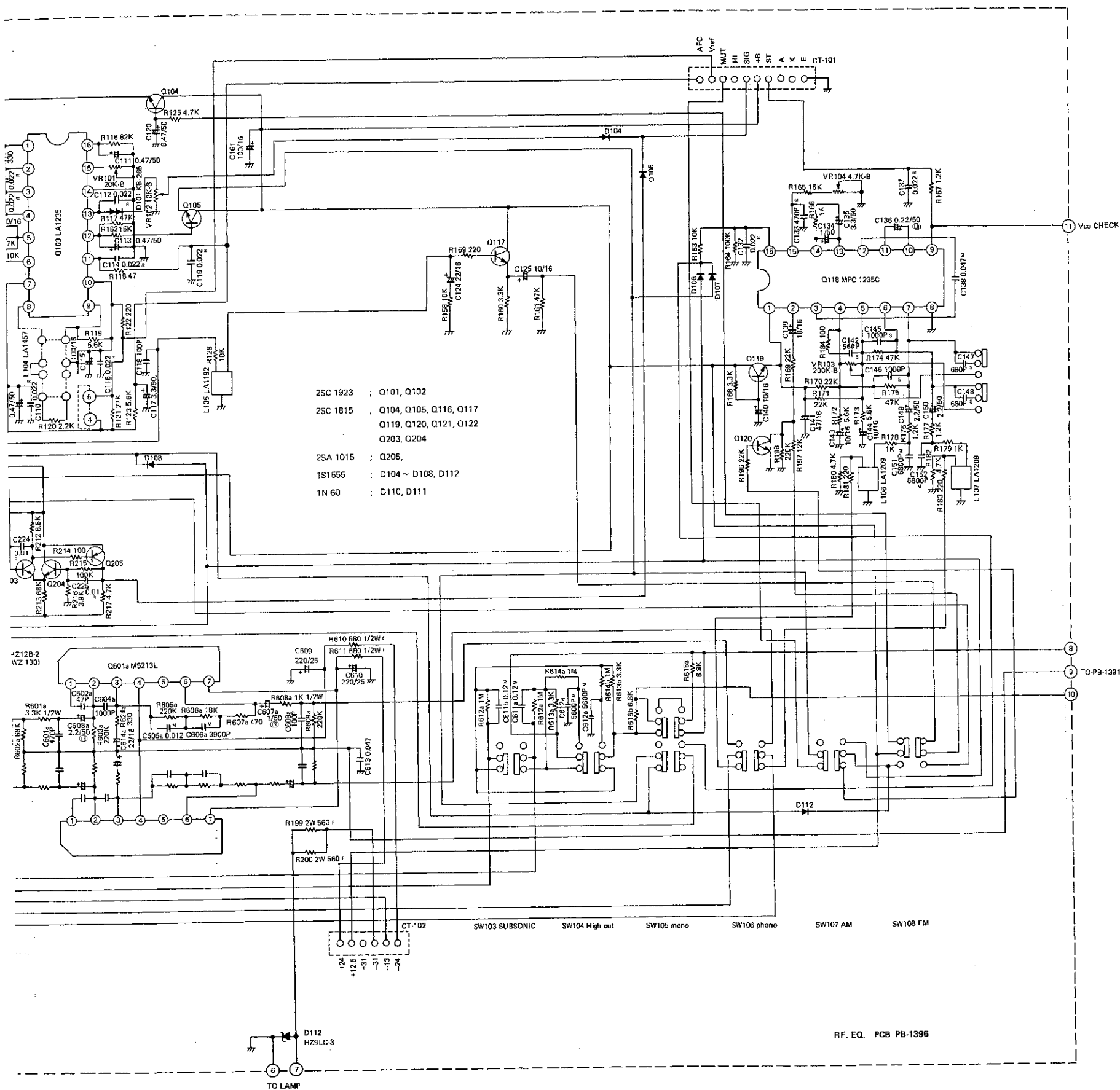

- NOTES
1. ALL RESISTORS IN OHMS, K : 10³, M : 10⁶
 2. ALL CAPACITORS IN FARAD μ : 10⁻⁶, P : 10⁻¹²
 3. TRANSISTORS AND DIODES MAY BE REPLACED WITH ANYTYPES HAVING COMPARABLE RATINGS.
 4. DUE TO CONTINUED RESEARCH FOR IMPROVEMENT LUX RESERVES THE RIGHT TO ALTER THE CIRCUITS AND SPECIFICATIONS WITHOUT NOTICE

R-5030 RF, EQ SECTION

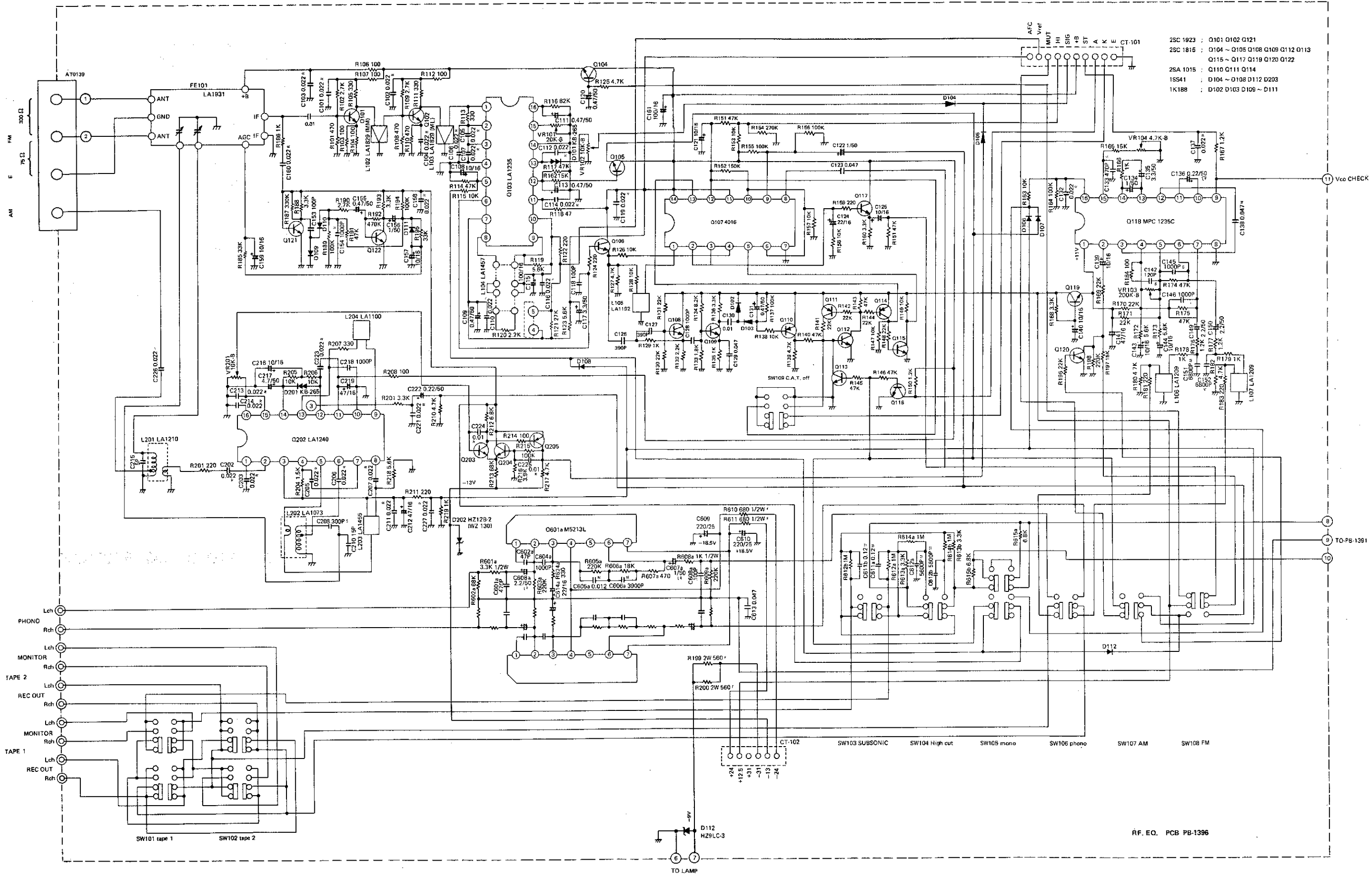

- 2SC 1923 : Q101 Q102 Q121
- 2SC 1815 : Q104 ~ Q105 Q108 Q109 Q112 Q113
- Q115 ~ Q117 Q119 Q120 Q122
- 2SA 1015 : Q110 Q111 Q114
- 1SS41 : D104 ~ D108 D112 D203
- 1K188 : D102 D103 D109 ~ D111

TO C
PB 1:
FM +.

TO-PB-1391

RF. EQ. PCB PB-1396

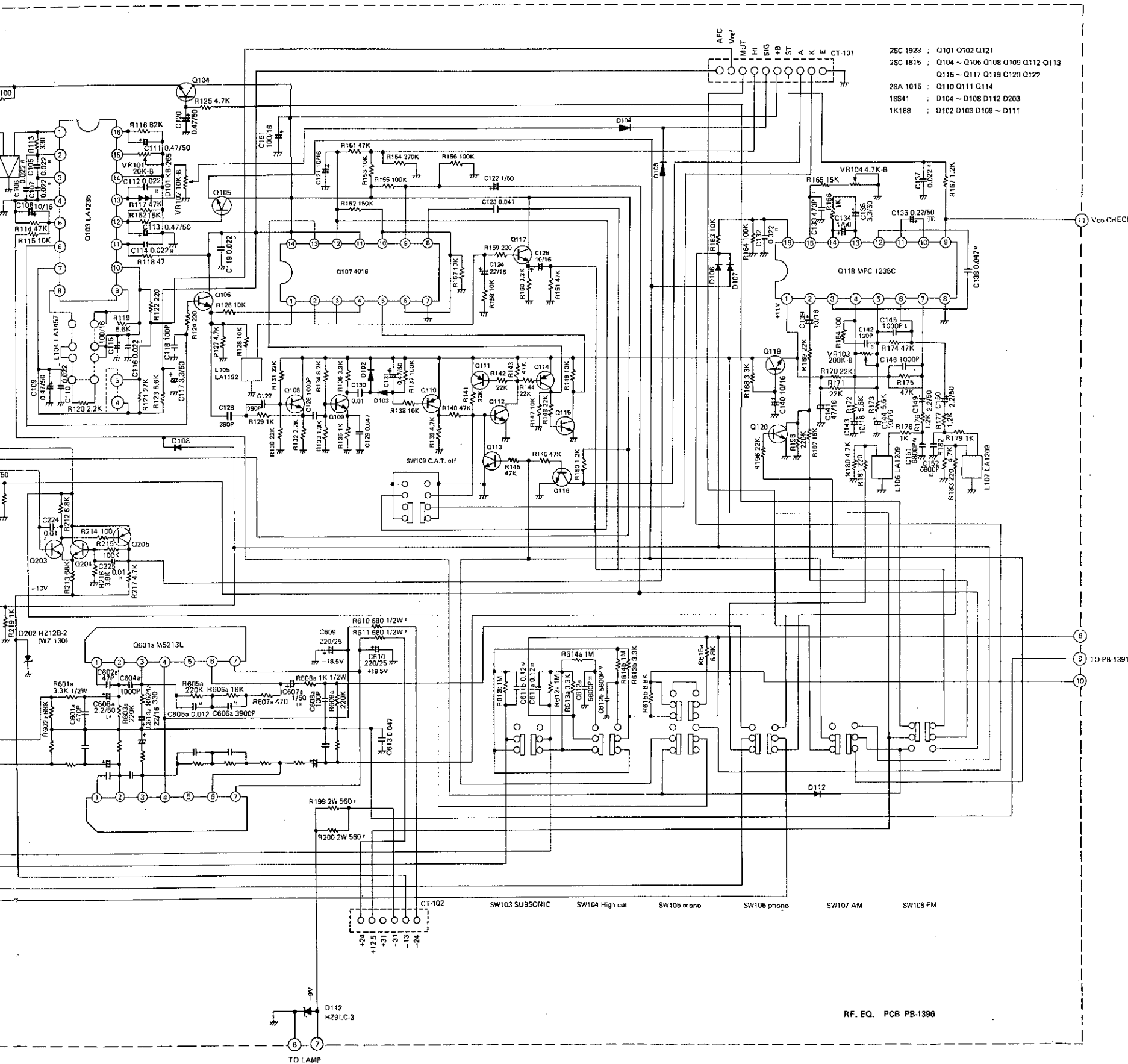

2SC 1923 : Q101 Q102 Q121
 2SC 1815 : Q104 ~ Q105 Q108 Q109 Q112 Q113
 Q115 ~ Q117 Q119 Q120 Q122
 2SA 1015 : Q110 Q111 Q114
 1S541 : D104 ~ D108 D112 D203
 1K188 : D102 D103 D109 ~ D111

RF. EQ. PCB PB-1396

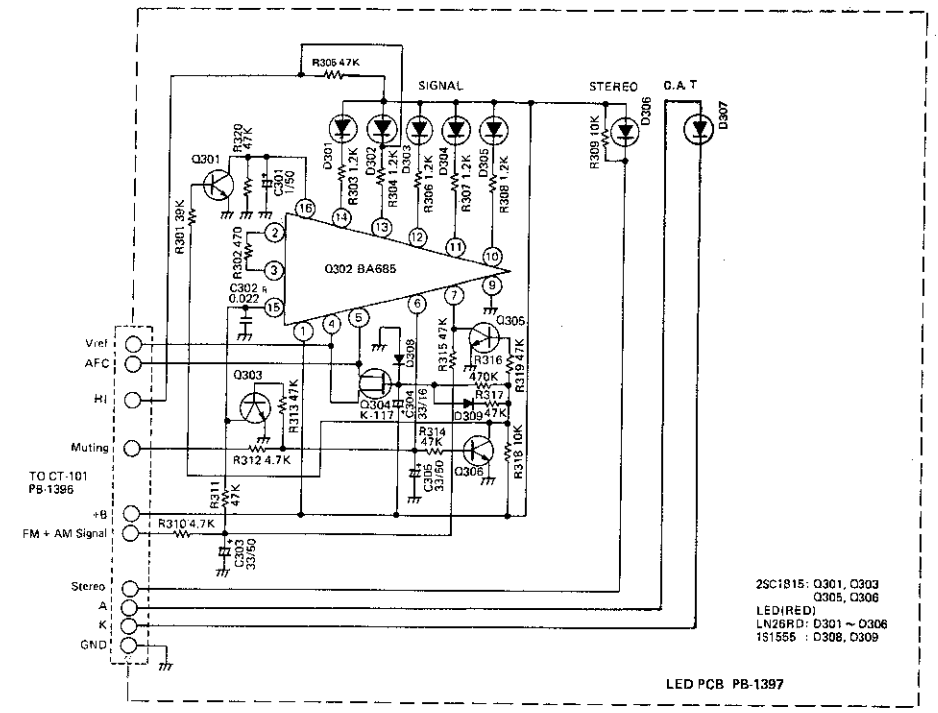

2SC1815 : Q301, Q302
 Q305, Q306
 LED (RED)
 LN2690 : Q301 ~ Q306
 1S1555 : D308, Q309

LED PCB PB-1397

NOTES

1. ALL RESISTORS IN OHMS, K : 10³, M : 10⁶
2. ALL CAPACITORS IN FARAD μ : 10⁻⁶, P : 10⁻¹²
3. TRANSISTORS AND DIODES MAY BE REPLACED WITH ANYTYPES HAVING COMPARABLE RATINGS.
4. DUE TO CONTINUED RESEARCH FOR IMPROVEMENT LUX RESERVES THE RIGHT TO ALTER THE CIRCUITS AND SPECIFICATIONS WITHOUT NOTICE

**R-5030 RF, EQ SECTION
(With C.A.T. Switch)**

Specifications

With C.A.T. Switch

Audio Section

Power Output:	35W minimum continuous per channel both channels driven into 8 ohms with no more than 0.03% total harmonic distortion.
Rated I.M.:	No more than 0.03% (8 ohms, 35W/ch, 60Hz: 7kHz = 4 : 1)
Frequency Response:	10Hz - 70kHz (<u>+1dB</u>)
Input Sensitivity:	2.2mV (phono) 150mV (monitor)
Input Impedance:	50k ohms (phono) 35k ohms (monitor)
Phono Overload Voltage:	150mV
S/N Ratio:	77dB (phono, IHF-A weighted, 5mV) 102dB (monitor, IHF-A weighted)
Residual Noise:	0.5mV
Tone Control:	Bass +7dB at 100Hz -10dB Treble +7dB at 10kHz -10dB
Filters:	Subsonic 30Hz (6dB/oct.) High Cut 7kHz (6dB/oct.)
Crosstalk:	70dB (monitor at 1kHz)
Loudness Control:	+8dB at 100Hz, +7.5dB at 10kHz (Loudness control: max., VR: -30dB)

FM Section

Usable Sensitivity:	Mono 10.3dBf (1.8 μ V)
50dB Quietening Sensitivity:	Mono 14.8dBf (3.0 μ V) (50 μ sec)
S/N Ratio at 65dBf:	82dB
Muting Threshold:	3 μ V
Frequency Response:	(30Hz - 15kHz) (<u>+1dB</u>)
Distortion at 65dBf:	(mono) (stereo)
100Hz:	0.15% 0.2%
1kHz:	0.12% 0.2%
6kHz:	0.3% 0.3%
Capture Ratio at 65dBf:	1.5dB
Image Response Ratio:	55dB
IF Response Ratio:	90dB
AM Suppression Ratio:	60dB
Stereo Separation:	42dB (100Hz) 48dB (1kHz), 42dB (10kHz)
Spurious Response Ratio:	80dB
Alternate Channel Selectivity:	65dB (<u>+400kHz</u>)
SCA Rejection Ratio:	60dB

AM Section

IHF Usable Sensitivity (1MHz):	500 μ V/m (loop ant.)
Image Response Ratio at 1MHz:	45dB
S/N Ratio:	58dB
Distortion:	0.5%

General

Dimensions:	438(W) x 384(D) x 85(H)mm (17.5" x 15.4" x 3.4")
Weight:	Net 7.7kgs (17.0 lbs.)

Specifications and appearance design subject to change without notice.

Specifications

Audio Section

Power Output:	38W minimum continuous per channel both channels driven into 8 ohms with no more than 0.04% total harmonic distortion
Rated I.M.:	No more than 0.04% (8 ohms, 38W/ch, 60Hz: 7kHz = 4 : 1)
Frequency Response:	10Hz - 70Hz (± 1 dB)
Input Sensitivity:	2.2mV (phono) 150mV (monitor)
Input Impedance:	50k ohms (phono) 35k ohms (monitor)
Phono Overload Voltage:	150mV
S/N Ratio:	77dB (phono, IHF-A weighted, 5mV) 102dB (monitor, IHF-A weighted)
Residual Noise:	0.5mV
Tone Control:	Bass +7dB at 100Hz -10dB Treble +7dB at 10kHz -10dB
Filters:	Subsonic 30Hz (6dB/oct.) High Cut 7kHz (6dB/oct.)
Crosstalk:	70dB (monitor at 1kHz)
Loudness Control:	+8dB at 100Hz, +7.5dB at 10kHz (Loudness control: max., VR: -30dB)

FM Section

Usable Sensitivity:	Mono 10.3dBf (1.8 μ V)
50dB Quieting Sensitivity:	Mono 14.8dBf (3.0 μ V) (50 μ sec)
S/N Ratio at 65dBf:	82dB
Muting Threshold:	3 μ V
Frequency Response:	(30Hz - 15kHz) (± 1 dB)
Distortion at 65dBf:	(mono) (stereo)
100Hz:	0.15% 0.25%
1kHz:	0.12% 0.2%
6kHz:	0.3% 0.3%
Capture Ratio at 65dBf:	1.5dB
Image Response Ratio:	55dB
IF Response Ratio:	90dB
AM Suppression Ratio:	60dB
Stereo Separation:	42dB (100Hz) 48dB (1kHz), 32dB (10kHz)
Spurious Response Ratio:	80dB
Alternate Channel Selectivity:	79dB (± 400 kHz)
SCA Rejection Ratio:	60dB
Adjacent Channel Selectivity:	60dB (40kHz dev. ± 300 kHz)

AM Section

IHF Usable Sensitivity (1MHz):	500 μ V/m (loop ant.)
Image Response Ratio at 1MHz:	45dB
S/N Ratio:	58dB
Distortion:	0.5%

General

Dimensions:	438(W) x 384(D) x 85(H)mm (17.5" x 15.4" x 3.4")
Weight:	Net 7.7kgs (17.0 lbs.)

Specifications and appearance design subject to change without notice.

LUX CORPORATION, JAPAN

1-1, 1-CHOME, SHINSENRI-NISHIMACHI, TOYONAKA-SHI, OSAKA 565
PHONE: 06-834.0004 TELEX: 5287106 LUXELE J

Printed in Japan.