

SERVICE MANUAL

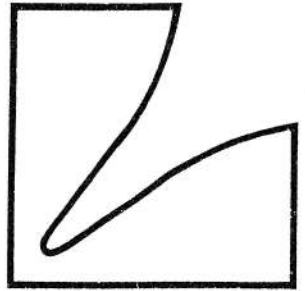

Stereo Integrated Amplifier

LV-103U

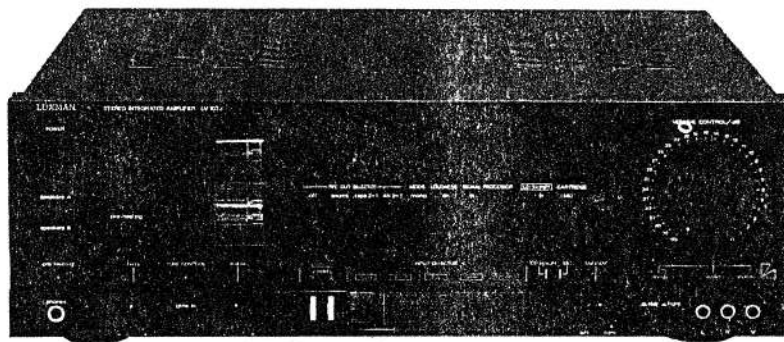

Contents

Specifications	2
Parts Locations and Disassembly Instructions	3 to 10
Adjustment Procedures	10 to 11
Adjustment Locations	11
Block Diagram	12
Schematic Diagram (JM/UK Model)	13 to 16
Schematic Diagram (AM Model)	17 to 20
Parts Layout on P.C. Board & Wiring Diagram	21 to 24
Electrical Parts List	28 to 35
Parts List by the Destination	36 to 38
Packing Method View	39
Packing Assembly Parts List	39
Cabinet Assembly Parts List	40
Exploded View (Cabinet)	41 to 42
Semiconductor Lead Identifications	45 to 48

Specifications

Power-Output(0.25% THD at 20Hz~20kHz)	50W
Head-phones Output(50W/8ohm-1kHz)	520mV±10%
Input Sensitivity(1kHz)	CD:150mV±15%, Tuner:150mV±15%, Tape-1,2:150mV ± 15%, AV-1,2:150mV ± 15%, Adaptor:150mV ±15%, Phono(MM):2mV±15%, Phono(MC):150μV ±15%
Input impedance(1kHz)	CD:47Kohm±15%, Tuner:47Kohm ±15%, Tape-1,2:47Kohm±15%, AV-1,2:47Kohm ± 15%, Adaptor:47Kohm±15%, Phono(MM):47Kohm ±15%, Phono(MC):100ohm ±15%
Frequency Response	CD:10-100kHz +0.6-2dB, Tuner:10-100kHz +0.6-2dB, Tape-1,2:10-100kHz +0.6-2dB Phono(MM):100Hz 13.09±0.5dB, Phono(MC):10kHz -13.74 ±0.5dB
Signal to Noise Ratio(Input Shorted)	CD:80dB, Tuner:80dB, Tape-1,2:80dB, AV-1,2:80dB, Adaptor:80dB, Phono(MM):50.5dB, Phono(MC):42.5dB
Cross Talk(10kHz)	CD:45dB, Tuner:45dB, Tape:45dB, AV:45dB, Adaptor:45dB, Phono:40dB
Tone Control Bass (100Hz)	±6 ±2dB
Treble(10kHz)	±6 ±2dB
Power Supply	100V, 50/60Hz(JM Model Only), 120V,60Hz(UN/UL Model Only), 220V, 50Hz(AM Model Only)
Power Consumption	170W(JM Model Only), 2.2A(UN/UL Model Only), 3.1A(AM Model Only)
Semiconductors	7ICs .43Transistors, 10FETs, 14Zener Diodes, 33Diodes, 2Vacuum Tubes
Dimension	438(W) × 148(H) × 353(D)mm
Weight	10Kg

NOTE: Due to continuing product improvement, specifications and design are subject to change.

Parts Locations and Disassembly Instructions

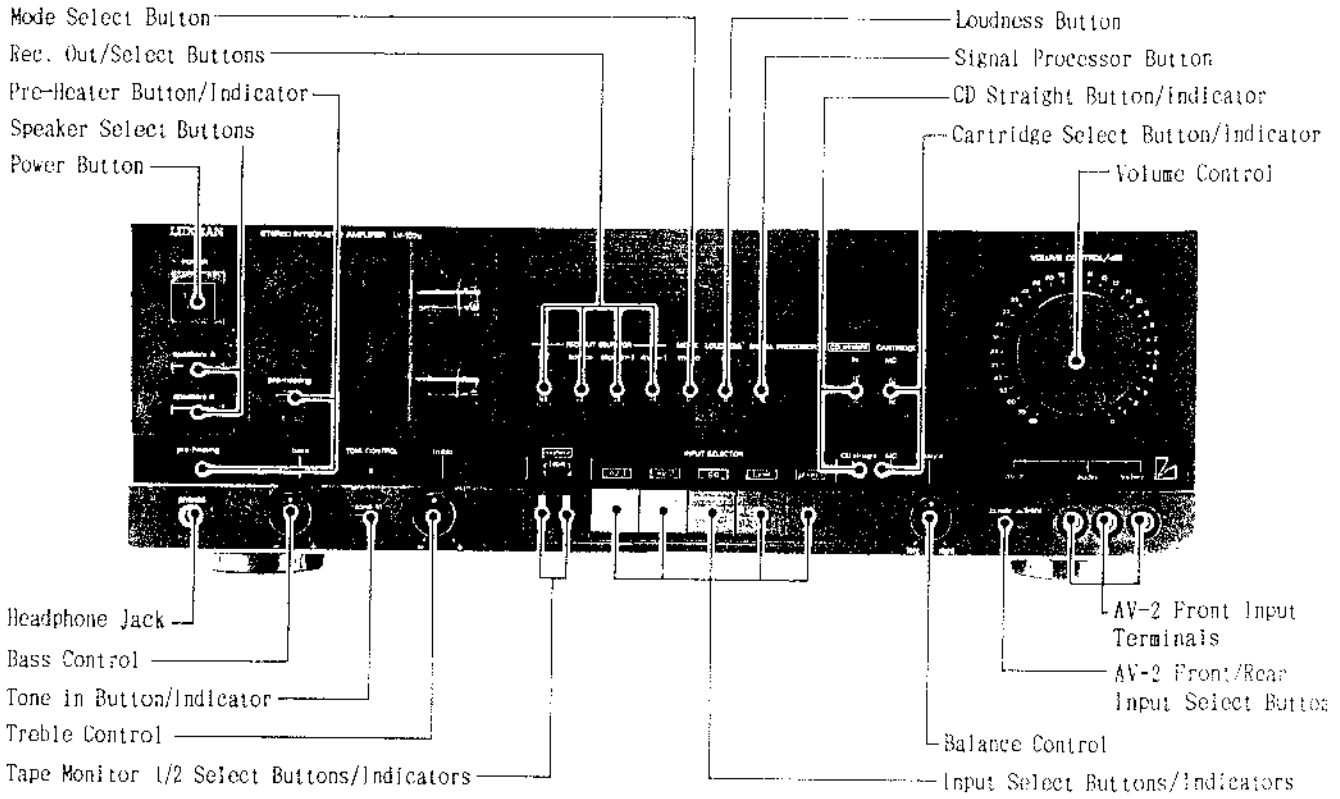

Figure 1
< 1 [X] >

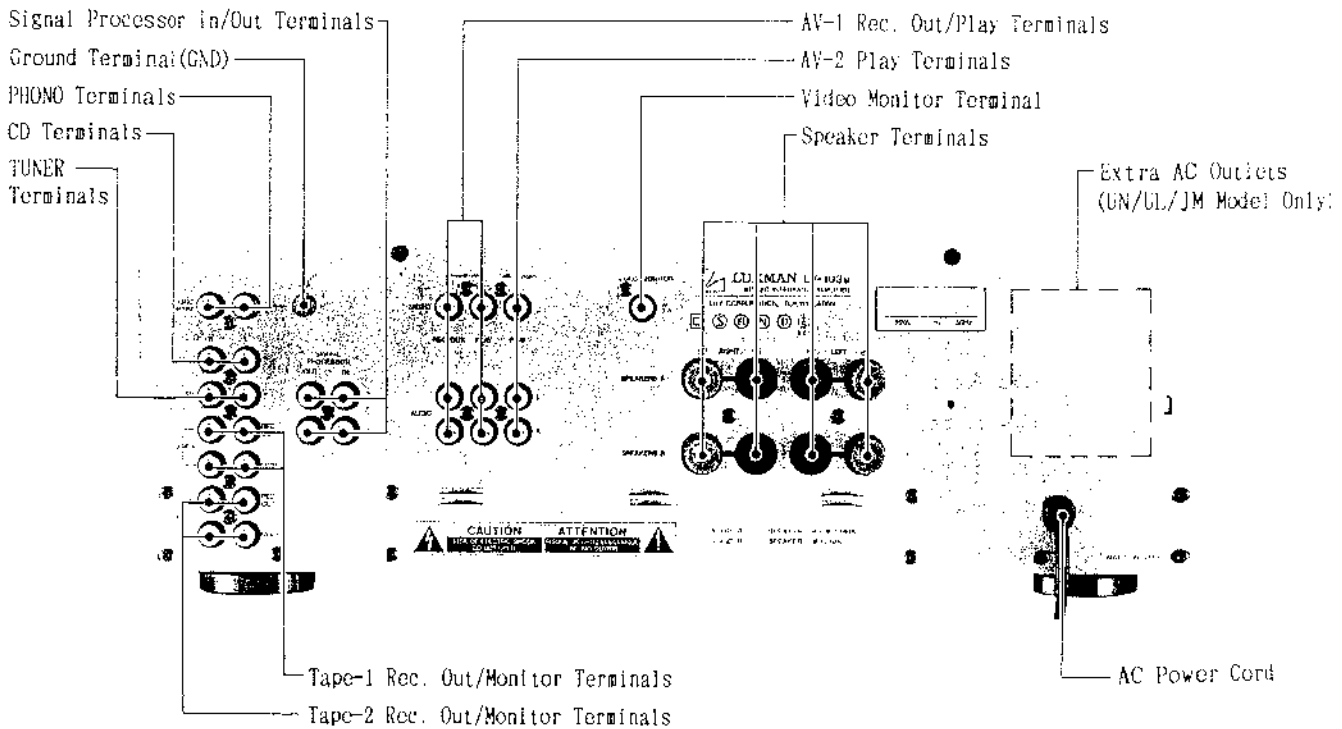

Figure 2
< 2 [X] >

1. Removal of Top Cover

- (1) Remove six screws marked "O" as shown in Figure 3 and 4.
- (2) Pull out the Top cover in the direction of the arrow as shown in Figure 3.

1. 上蓋の外し方

- (1) 6本のネジ "O" を外します。(3, 4図参照)
- (2) 矢印の方向に引き上げれば、上蓋は外すことができます。(3図参照)

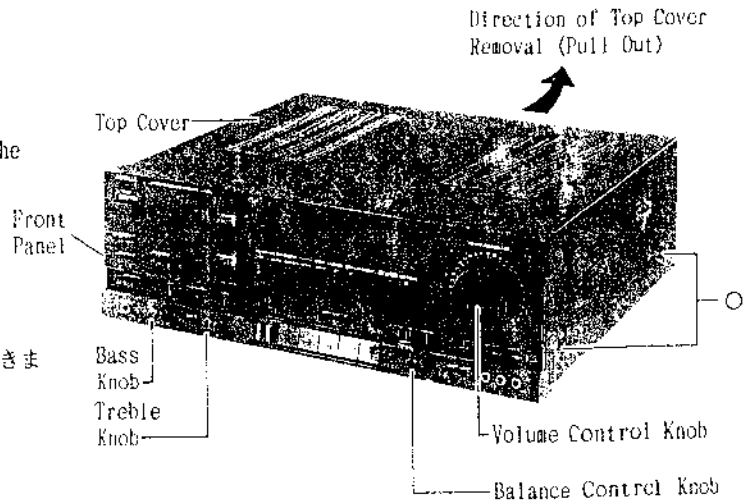

Figure 3
< 3図 >

2. Removal of Front Panel

- (1) Remove the volume control knob as shown in Figure 3.
- (2) Remove three screws marked "⊕" as shown in Figure 5.
- (3) Front panel can be removed by pulling it forward. But when the panel is engaged tightly, pull the panel end little by little, and the panel will be removed easily.

2. フロント・パネルの外し方

- (1) 上蓋を外してから、ボリューム・コントロール・ツマミを外します。(3図参照)
- (2) 3本のネジ "⊕" を外します。(5図参照)
- (3) フロント・パネルを手前に引いて外します。パネルを外すときパネルはセットにしっかりと取り付けられていますので、パネルの両端を持って少しづつ引くようにして外してください。

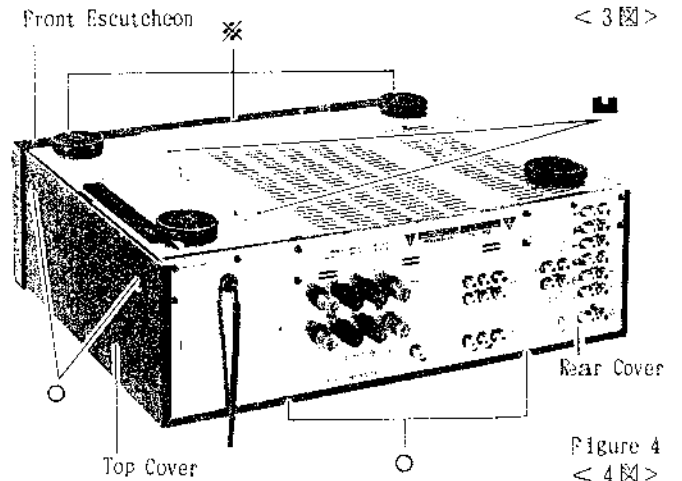

Figure 4
< 4図 >

3. Removal of Front Escutcheon

- (1) After removal of Front Panel, remove three control knobs (bass, treble, balance), remove two hooks (a), and remove six screws marked "※" as shown in Figure 3, 4 and 6.
- (2) Disconnect all wires from the Front Escutcheon.
- (3) The Front Escutcheon with Function LED, Tone and Headphone P.C. Boards can be removed completely.

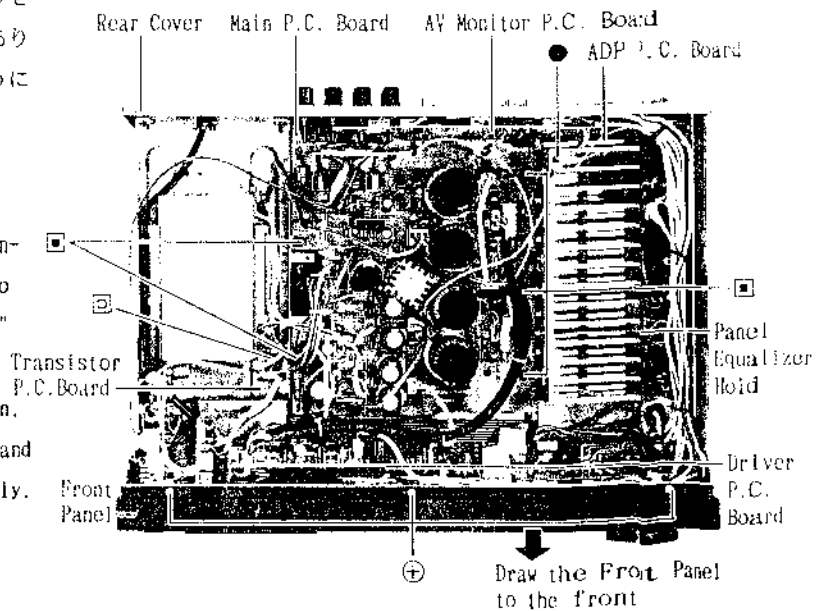

Figure 5
< 5図 >

3. 前面飾り板の外し方

- (1) フロント・パネルを外した後、3個のコントロール・ツマミ（バス、トレブル、バランス）と、2本のフック(a)、それに6本のネジ“※”を外します。
（3、4、6図参照）
- (2) つぎに前面飾り板から出ているすべてのリード線を外します。
- (3) 前面飾り板には、ファンクション基板、トーン基板及びヘッドホン基板がついていますので、これらの基板も一緒に外れます。

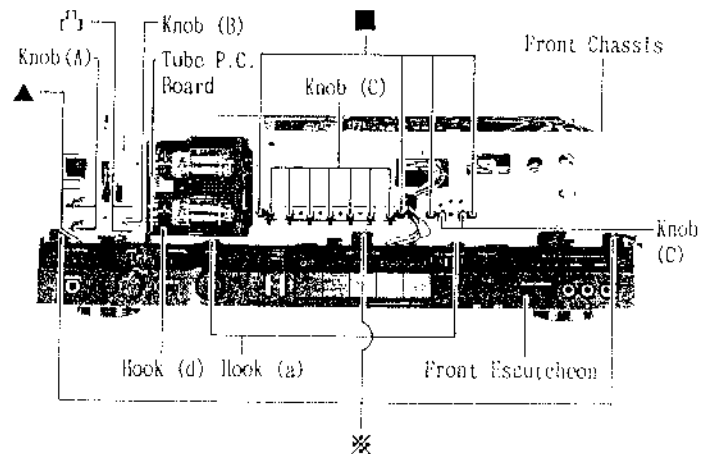

Figure 6
< 6図 >

4. Removal of Function LED P.C. Board

- (1) After removal of Front Escutcheon, remove four hooks (b) as shown in Figure 7.

4. ファンクションLED基板の外し方

- (1) 前面飾り板を外した後、4本のフック(b)を外しますと、ファンクションLED基板は外れます。
（7図参照）

5. Removal of Tone Control LED P.C. Board

- (1) After removal of Front Escutcheon, remove two hooks (c) as shown in Figure 7.

5. トーン・コントロール・LED基板の外し方

- (1) 前面飾り板を外した後、2本のフック(c)を外しますと、トーン・コントロール・LED基板は外れます。
（7図参照）

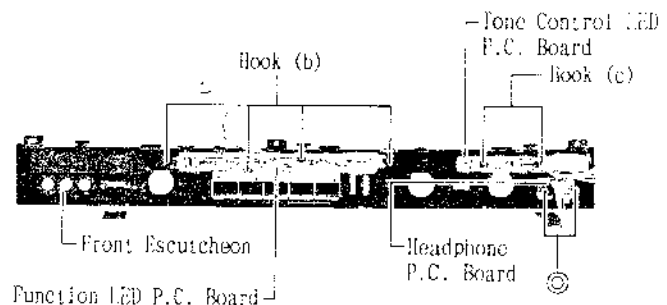

Figure 7
< 7図 >

6. Removal of Headphone P.C. Board

- (1) After removal of Front Escutcheon, remove two screws marked "◎" as shown in Figure 7.

6. ヘッド・ホン基板の外し方

- (1) 前面飾り板を外した後、2本のネジ“◎”を外しますと、ヘッド・ホン基板は外れます。
（7図参照）

7. Removal of Front Chassis

- (1) After removal of Front Escutcheon, remove seven screws marked "☆" as shown in Figure 8.
- (2) Remove Front Chassis upward and then proceed to Items 7-1~7-10.

7. 前面シャーシの外し方

- (1) 前面飾り板を外した後、7本のネジ"☆"を外します。(8図参照)
- (2) 上部前面シャーシを外し、7-1~7-10項の基板の外し方を進めます。

7-1. Removal of Driver P.C. Board

- (1) Remove two screws marked "◆" as shown in Figure 8.
- (2) Disconnect all wires from the Driver P.C. Board

7-1. ドライバー基板の外し方

- (1) 2本のネジ"◆"を外します。(8図参照)
- (2) ドライバー基板から出ているすべてのリード線を外しますと、ドライバー基板は外れます。

7-2. Removal of Transistor P.C. Board

- (1) Remove a screw marked "回" as shown in Figure 5.
- (2) Disconnect all wires from the Transistor P.C. Board.

7-2. トランジスタ基板の外し方

- (1) 1本のネジ"回"を外します。(5図参照)
- (2) トランジスタ基板から出ているすべてのリード線を外しますと、トランジスタ基板は外れます。

7-3. Removal of AC P.C. Board

- (1) Remove three knobs (A) and remove four screws marked "▲" as shown in Figure 6.
- (2) Disconnect all wires from the AC P.C. Board.

7-3. AC基板の外し方

- (1) 3個のつまみ(A)を外し、4本のネジ"▲"を外します。(6図参照)
- (2) AC基板から出ているすべてのリード線を外しますと、AC基板は外れます。

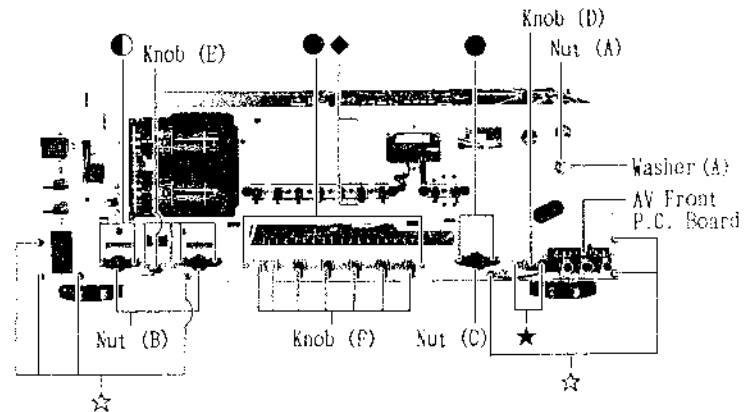

Figure 8
< 8図 >

7-4. Removal of Heat-Up Switch P.C. Board

- (1) Remove one Knob (B) and remove two screws marked "凸" as shown in Figure 6.
- (2) Disconnect all wires from the Heat up Switch P.C. Board.

7-4. ヒート・アップ・スイッチ基板の外し方

- (1) ツマミ(B) 1個を外し、2本のネジ"凸"を外します。(6図参照)
- (2) ヒート・アップ・スイッチ基板から出ているすべてのリード線を外しますと、ヒート・アップ・スイッチ基板は外れます。

7-5. Removal of Tube P.C. Board

- (1) Remove two screws marked "■" as shown in Figure 9.
- (2) Remove one hook (d) as shown in Figure 6.
- (3) Disconnect all wires from the Tube P.C. Board.

7-5. チューブ基板の外し方

- (1) 2本のネジ"■"を外します。(9図参照)
- (2) フック(d) 1本を外します。(6図参照)
- (3) チューブ基板から出ているすべてのリード線を外しますと、チューブ基板は外れます。

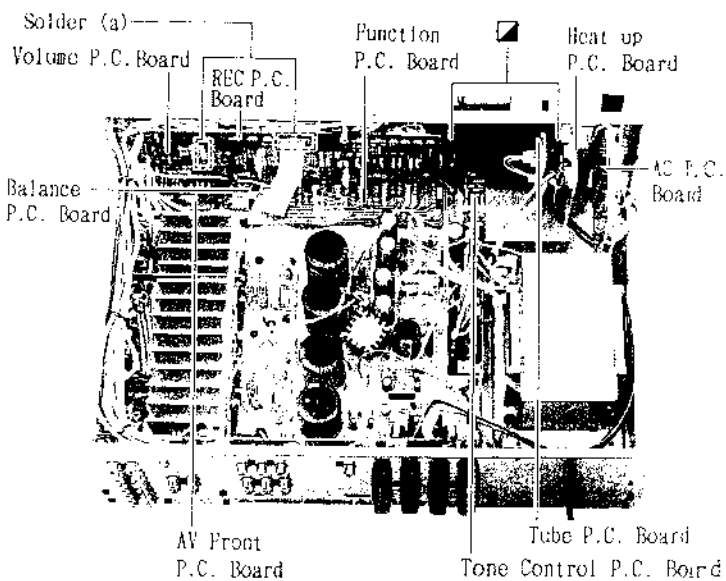

Figure 9
< 9図 >

7-6. Removal of REC P.C. Board

- (1) Remove four screws marked "■" and remove nine knobs (c) as shown in Figure 6.
- (2) Remove two solders (a) as shown in Figure 9.
- (3) Disconnect all wires from the REC P.C. Board.

7-6. REC基板の外し方

- (1) 4本のネジ"■"と9個のツマミ(c)を外します。(6図参照)
- (2) 半田付け(a)を2ヶ所外します。(9図参照)
- (3) REC基板から出ているすべてのリード線を外しますと、REC基板は外れます。

7-7. Removal of Volume P.C. Board

- (1) Remove one nut (A) and one washer (A) shown in Figure 8.
- (2) Disconnect all wires from the Volume P.C. Board.

7-7. ボリューム基板の外し方

- (1) ナット(A) 1個とワッシャー(A) 1個を外します。
(8図参照)
- (2) ボリューム基板から出ているすべてのリード線を外しますと、ボリューム基板は外れます。

7-8. Removal of Tone Control P.C. Board

- (1) Remove one knob (E) and six screws marked "●" as shown in Figure 8.
- (2) Remove two nuts (B) as shown in Figure 8.
- (3) Disconnect all wires from the Tone Control P.C. Board.

7-8. トーン・コントロール基板の外し方

- (1) ツマミ(E)1個と6本のネジ"●"を外します。
(8図参照)
- (2) ナット(B) 2個を外します。(8図参照)
- (3) トーン・コントロール基板から出ているすべてのリード線を外しますと、トーン・コントロール基板は外れます。

7-9. Removal of Function P.C. Board and Balance P.C. Board

- (1) Remove seven knobs (F) and remove five screws marked "●" as shown in Figure 5, 8.
- (2) Remove one nut (c) as shown in Figure 8.
- (3) Disconnect all wires from the Function P.C. Board and Balance P.C. Board.

7-9. ファンクション基板とバランス基板の外し方

- (1) 7個のツマミ(F) と5本のネジ"●"を外します。
(8図参照)
- (2) ナット(c) 1個を外します。(8図参照)
- (3) ファンクション基板とバランス基板から出ているすべてのリード線を外しますと、ファンクション基板とバランス基板は外れます。

7-10. Removal of AV Front P.C. Board

- (1) Remove one knob (D) and remove two screws marked "★" as shown in Figure 8.
- (2) Disconnect all wires from the AV Front P.C. Board.

7-10. AV・フロント基板の外し方

- (1) ツマミ(D) 1個を外し、次に2本のネジ"★"を外します。(8図参照)
- (2) AV・フロント基板から出ているすべてのリード線を外しますと、AV・フロント基板は外れます。

8. Removal of Equalizer P.C. Board

- (1) Remove six screws marked "⊗" as shown in Figure 10 and 11.
- (2) Remove the equalizer hold panel as shown in Figure 5.
- (3) Disconnect all wires from the equalizer P.C. Board.

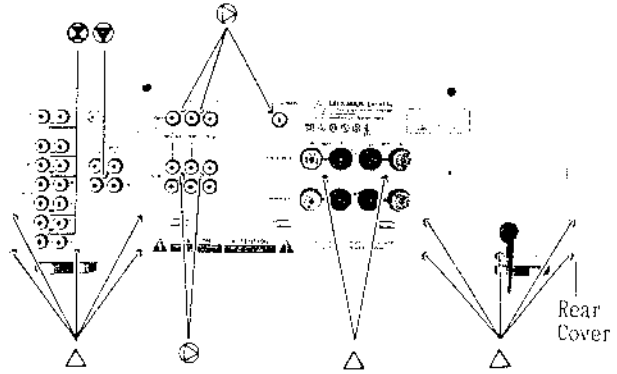

Figure 10
<10図>

8. イコライザー基板の外し方

- (1) 6本のネジ“⊗”を外します。(10, 11図参照)
- (2) イコライザー基板の保持板を外します。(5図参照)
- (3) イコライザー基板から出ているすべてのリード線を外しますと、イコライザー基板は外れます。

9. Removal of Rear Cover

- (1) Remove twelve screws marked "△" as shown in Figure 10.
- (2) Disconnect all wires from the AC Outlet, AV Monitor and ADP P.C. Board.
- (3) The rear cover with AV Monitor and Adapter P.C. Board can be removed completely.

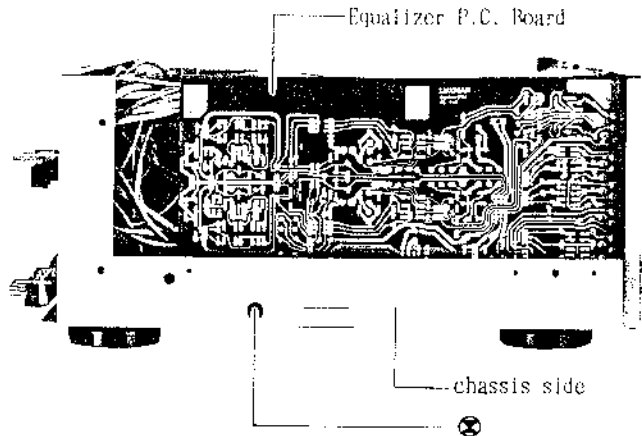

Figure 11
<11図>

9. 後面カバーの外し方

- (1) 12本のネジ“△”を外します。(10図参照)
- (2) ACアウトレット、AV・モニター基板及びアダプター基板から出ているすべてのリード線を外します。
- (3) 後面カバーにはAV・モニター基板とアダプター基板がついていますので、これらの基板を一緒に外すことができます。

10. Removal of AV Monitor P.C. Board

- (1) Remove five screws marked "⊗" as shown in Figure 10.

10. AV・モニター基板の外し方

- (1) 5本のネジ“⊗”を外しますと、AV・モニター基板は外れます。(10図参照)

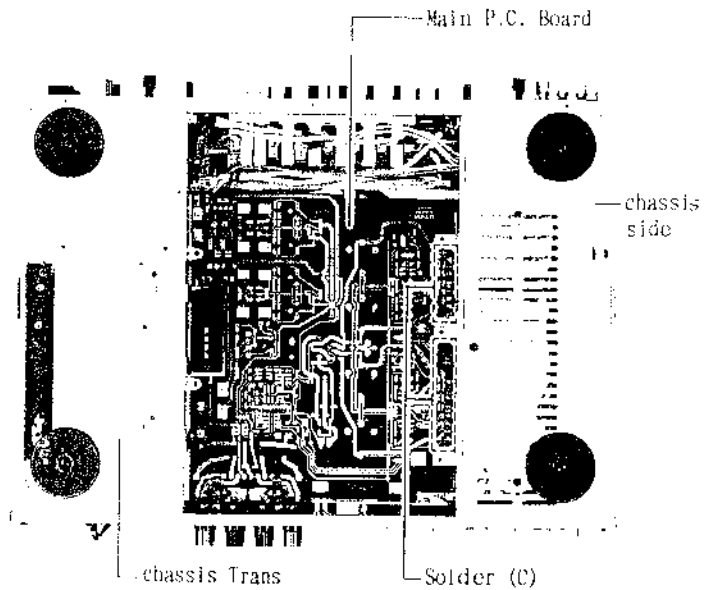

Figure 12
<12図>

11. Removal of ADP P.C. Board

- (1) Remove one screw marked "⊙" as shown in Figure 10.

11. アダプター基板の外し方

- (1) ネジ "⊙" 1本を外しますと、アダプター基板は外れます。(10図参照)

12. Removal of Bottom Chassis

- (1) Remove two screws marked "■" as shown in Figure 4.

12. 底蓋の外し方

- (1) 2本のネジ "■" を外しますと、底蓋は外れます。(4図参照)

13. Removal of Main P.C. Board

- (1) Remove five screws marked "□" and two solders (c) as shown in Figure 5. 12.
 (2) Disconnect all wires from the Main P.C. Board.

13. メイン基板の外し方

- (1) 5本のネジ "□" と半田付け(C) 2ヶ所を外します。(5. 12図参照)
 (2) メイン基板から出ているすべてのリード線を外しますと、メイン基板は外れます。

Adjustment Procedures

1. Connection

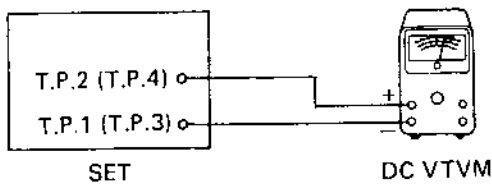

Figure 13

3. Adjustment Procedure

- (1) Idling Adjustment (Figure 13.14)

Adjust VR7301 (VR7302) until 65mV is obtained between T.P.1 (T.P.3) and T.P.2 (T.P.4).

Note: This adjustment should be made approx 5 minutes after the power on.

2. Control Settings

- Power Switch ON
 Volume Control Minimum
 (fully counterclockwise)
 Treble Control Center Position
 Bass Control Center Position
 Balance Control Center Position
 Others OFF

調整方法

1. 接続図

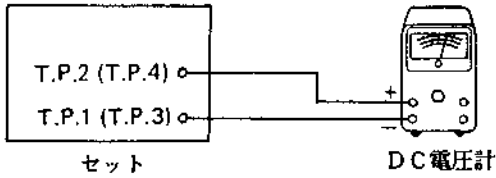

<13図>

3. 調整方法

(1) アイドリング調整 (13図、14図参照)

・国内向

TP1 (TP3)、TP2 (TP4) 間の電圧が65mVになる様に、VR7301 (VR7302) で調整します。

(注) : この調整は電源を入れて5分以上たってから行ってください。

2. スイッチ類の位置

電源スイッチ ON

ボリューム調整つまみ 最小

(反時計方向いっぱいに戻す)

トレブル/バス/バランス調整つまみ 中央位置

他のスイッチ OFF

Adjustment Locations

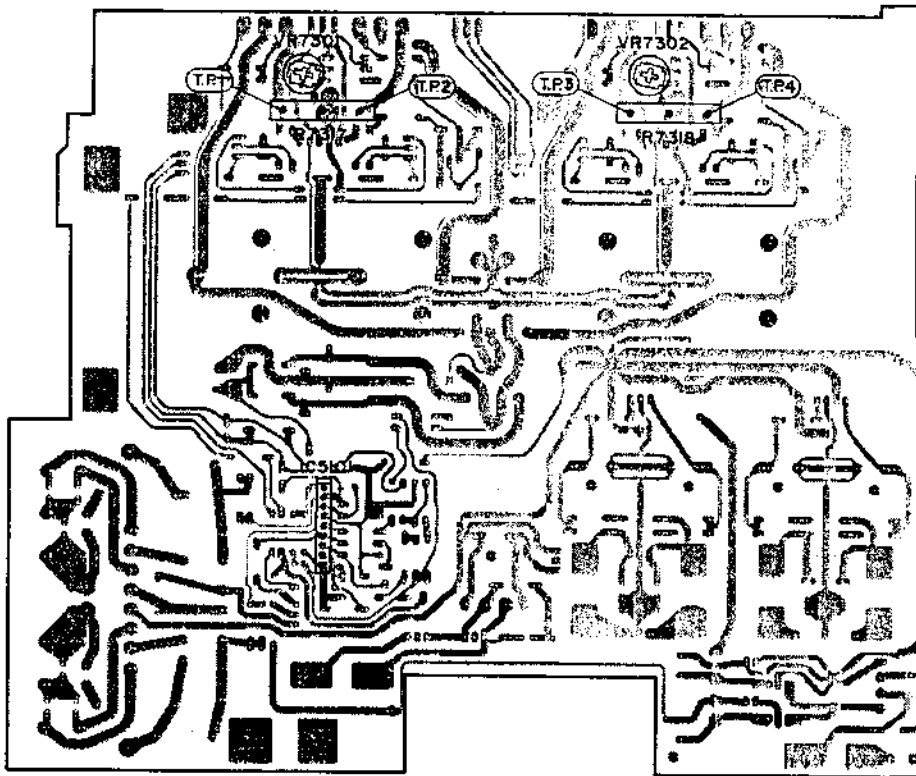

Main P.C. Board (Component Side)

メイン基板 (部品取付側)

Figure 14

<14図>

Block Diagram

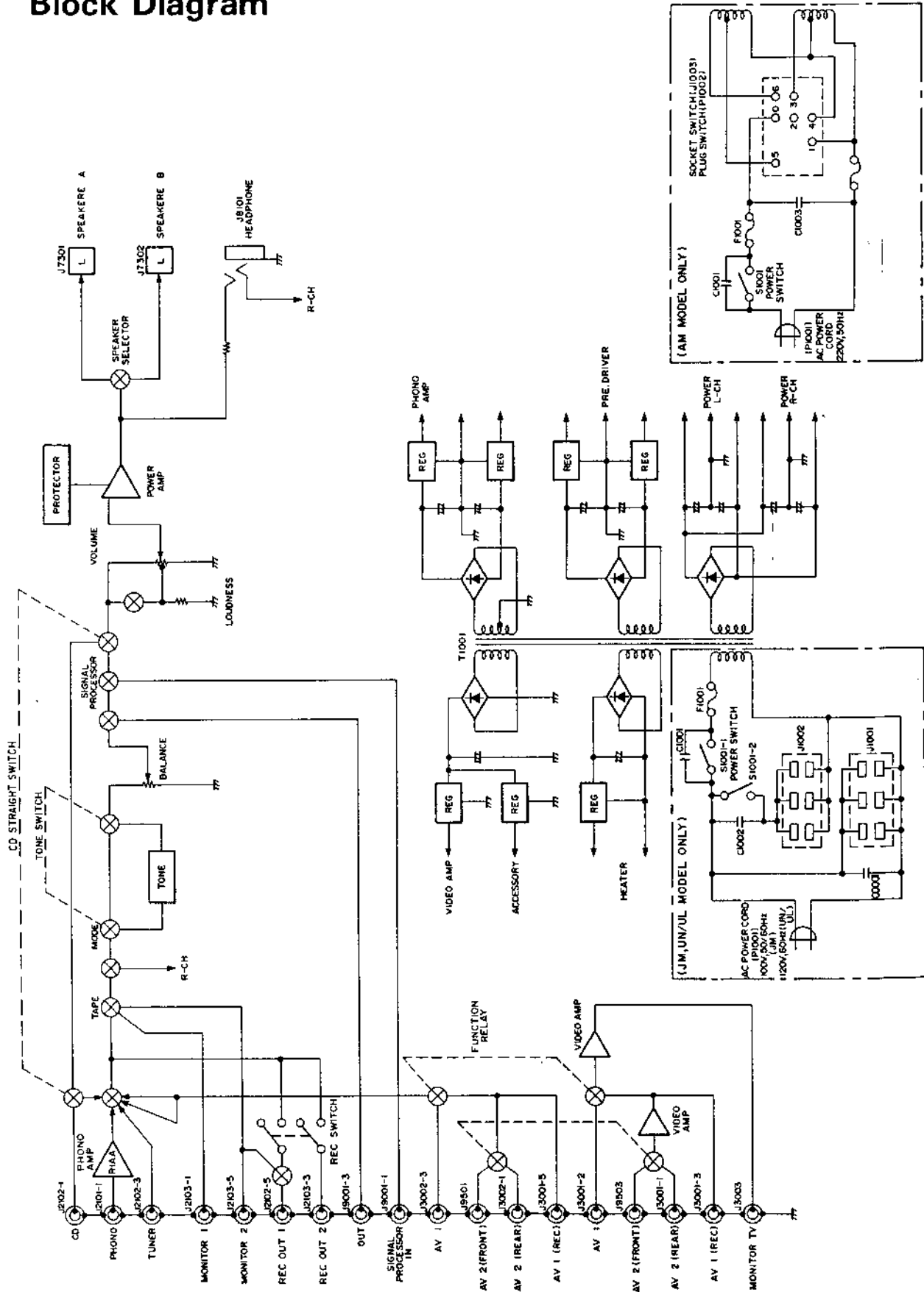

Schematic Diagram (JM/UN/UL model)

IC's	IC3001										IC2101									
TRANSISTORS(Q)	Q117	Q2101	Q112	Q3001	Q113	Q115	Q1501	Q101	Q107	Q104	Q7107	Q7108	Q7102	Q7109	Q4901	Q7305	Q7308	Q7301		
	Q118	Q1109	Q110	Q3002	Q114	Q116	Q1502	Q103	Q106	Q102	Q7101	Q7106	Q7108	Q7110	Q4902	Q7307	Q7306	Q7311		
	Q3003	Q3004	Q1111	Q2102				Q105	Q108		Q7103	Q7104				Q7309	Q7310	Q7303		

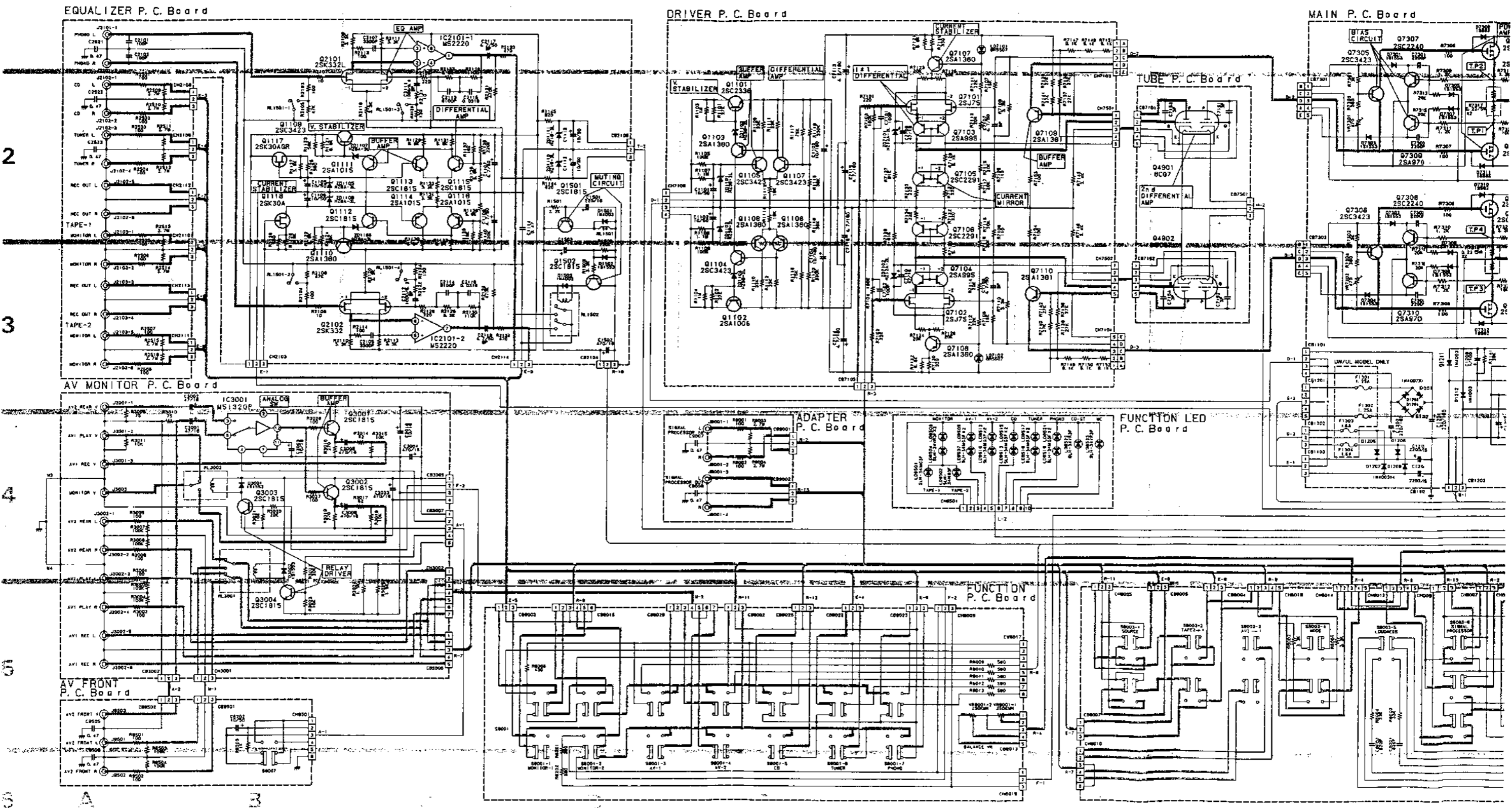

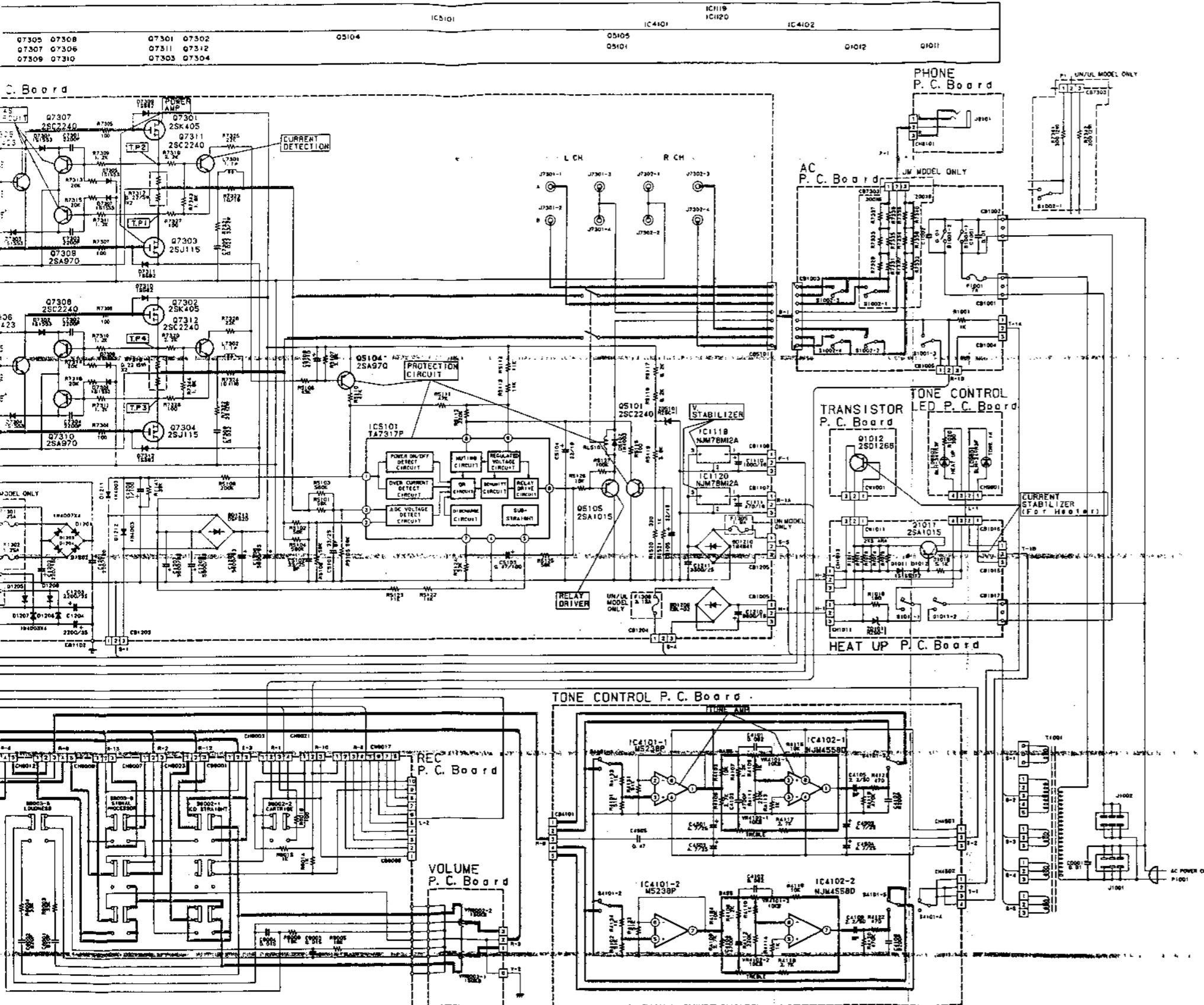

	C	B	E
Q101	0.2V	7V	7.7V
Q102	7.7V	6.2V	5.5V
Q103	126V	100.5V	99.9V
Q104	-126V	-100.5V	-99.9V
Q105	0V	62.5V	63.1V
Q106	0V	-62.5V	-63.1V
Q107	62.5V	37.4V	36.8V
Q108	-62.5V	-37.4V	-36.8V
Q109	30.5V	22.8V	22V
Q110	-30.5V	-22.8V	-22V
Q111	0V	16.3V	16.9V
Q112	0V	-16.3V	-16.9V
Q113	17V	5.6V	5V
Q114	-17V	-5.6V	-5V
Q115	16.9V	5.6V	5V
Q116	-16.9V	-5.6V	-5V
Q3001	12.1V	5.6V	5.1V
Q3002	12.1V	5.6V	5.1V
Q3003	0.1V	0.8V	0V
Q3004 (AV-1)	12.1V	0V	0V
Q3004 (Front)	0.1V	0.8V	0V
Q5101	1.3V	0.3V	0V
Q5104	-0.7V	49.3V	49.3V
Q5105	0V	4.2V	3.6V
Q7103-1	-95V	-12.8V	-12V
Q7103-2	-95V	-12.8V	-12V
Q7104-1	-95V	-12.8V	-12V
Q7104-2	-95V	-12.8V	-12V
Q7105-1	-95V	-96.7V	-99.3V
Q7105-2	-98.7V	-96.7V	-99.3V
Q7106-1	-95V	-12.8V	-12V
Q7106-2	-98.7V	-96.7V	-99.3V
Q7107	30V	98.7V	99.3V
Q7108	30V	98.7V	99.3V
Q7109	-99.9V	-3V	-2.4V
Q7110	-99.9V	-3V	-2.4V
Q7305	2V	-1.8V	-2.4V
Q7308	2V	-1.8V	-2.4V
Q7307	2V	0V	0V
Q7308	2V	0V	0V
Q7309	-2.4V	0V	0V
Q7310	-2.4V	0V	0V
Q7311	49.3V	0V	0V
Q7312	49.3V	0V	0V

	D	G	S
Q1117	30.5V	5.6V	6.3V
Q1118	-5.6V	-30.5V	-29.8V
Q2101	10.6V	0V	0.2V
Q2102	10.6V	0V	0.2V
Q7101-1	-12V	0V	-0.3V
Q7101-2	-12V	0V	-0.3V
Q7102-1	-12V	0V	-0.3V
Q7102-2	-12V	0V	-0.3V
Q7301	49.3V	2V	0V
Q7302	49.3V	2V	0V
Q7303	-49.3V	-2.4V	0V
Q7304	-49.3V	-2.4V	0V

	P	G	K	P	G	K
Q4901	-3V	55V	-92V	-3V	-95V	-92V
Q4902	-3V	-55V	-92V	-3V	-95V	-92V

IC1119	
1	12.1V
2	0V
3	16.2V

IC3001	
1	—
2	12.1V
3	4.4V
4	12.1V
5	4.3V
6	—
7	0V
8	—
9	—
10	—
11	5V
12	5.6V
13	—
14	4.4V
15	4.3V
16	4.4V

IC4101	
1	0V
2	0V
3	0V
4	-14.4V
5	0V
6	0V
7	0V
8	14.4V

IC1120	
1	12.1V
2	0V
3	16.2V

IC2101	
1	0V
2	16.6V
3	16.6V
4	-22V
5	16.6V
6	16.6V
7	0V
8	22V

IC4102	
1	0V
2	0V
3	0V
4	-14.3V
5	0V
6	0V
7	0V
8	14.3V

IC5101	
1	-0.7V
2	0V
3	0V
4	0V
5	-0.8V
6	6.3V
7	0V
8	1.3V
9	5.1V

NOTES:
 1. All resistance values are in ohms. K = 1,000
 2. All capacitance values are in microfarads. P = $\frac{1}{1,000,000}$

Voltage Measuring Conditions
 • Power Supply Voltage: AC100V (JM model only)
 AC120V (UN/UL model only)
 • Measuring Meter: Digital Volt Meter
 • Measuring point reference: Between Ground
 • Measuring conditions: No Signal Input

Schematic Diagram (AM model)

IC's	IC3001						IC2101						Q101-Q108						Q7101-Q7108		Q4901-Q4902		Q7301-Q7310		
TRANSISTORS(Q)	Q1117 Q1118 Q3003 Q3004	Q2101 Q1109 Q1111 Q2102	Q1112 Q3002 Q1114 Q2102	Q3001 Q3002	Q1113 Q1114 Q1115 Q1116	Q1501 Q1502	Q1101 Q1103 Q1105	Q1107 Q1106 Q1108	Q1104 Q1102	Q7107 Q7101 Q7103	Q7105 Q7106 Q7104	Q7102 Q7108	Q7109 Q7110	Q4901 Q4902	Q7305 Q7307 Q7309	Q7308 Q7306 Q7310	Q7301 Q7311 Q7303								

EQUALIZER P. C. Board

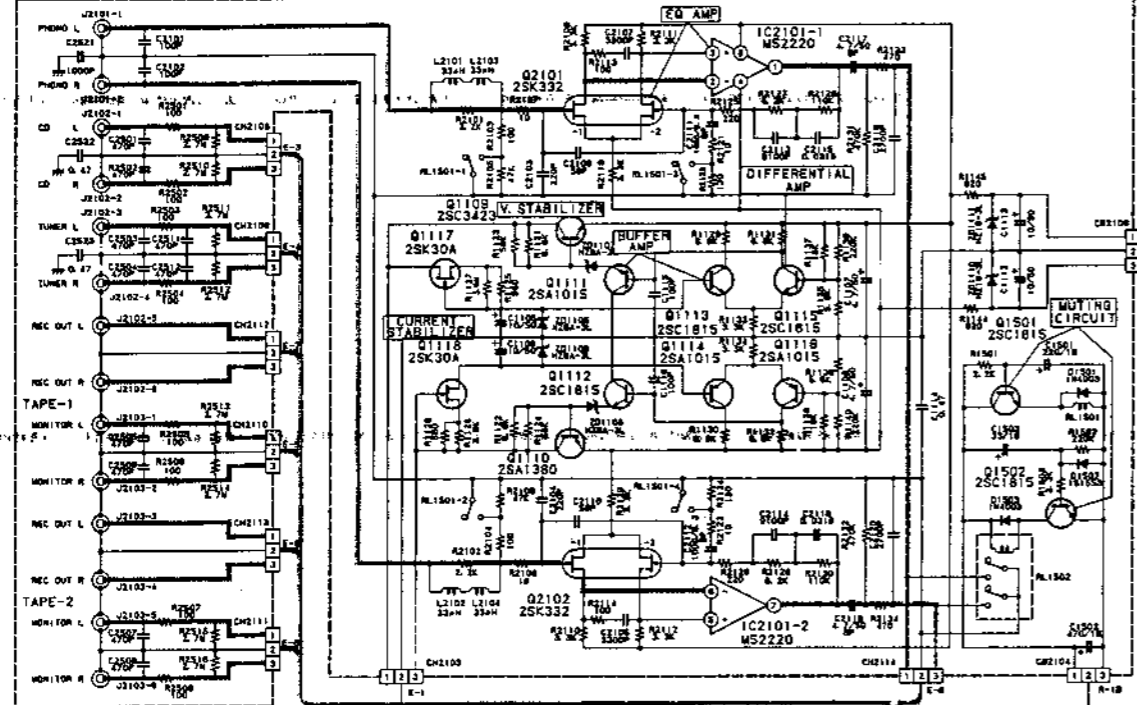

DRIVER P. C. Board

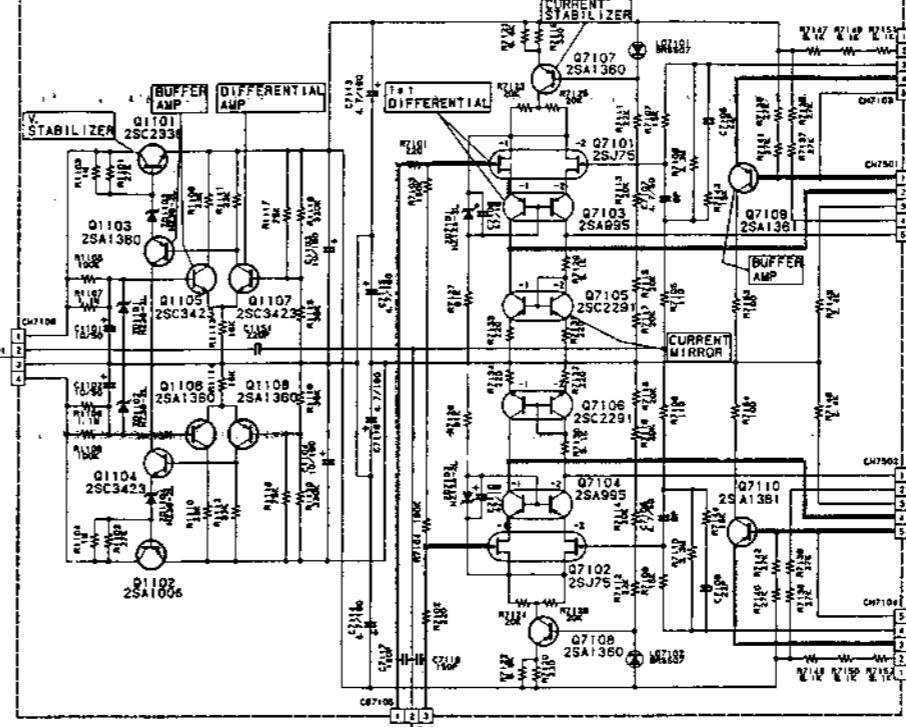

MAIN P. C. Board

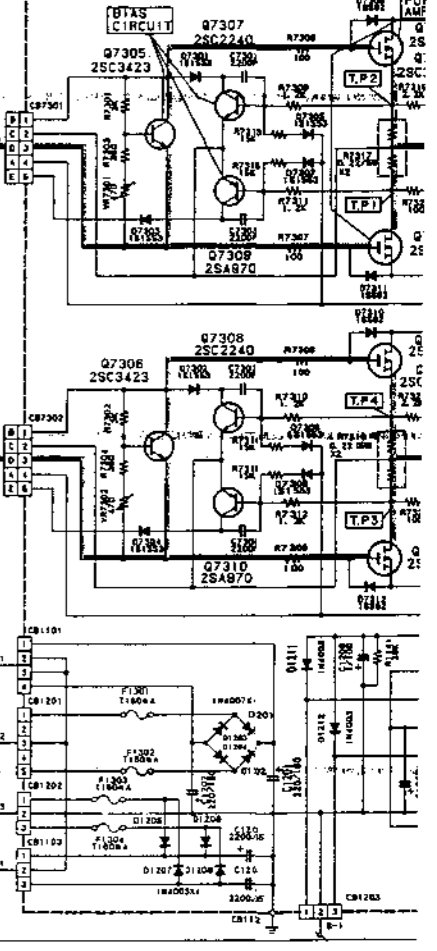

AV MONITOR P. C. Board

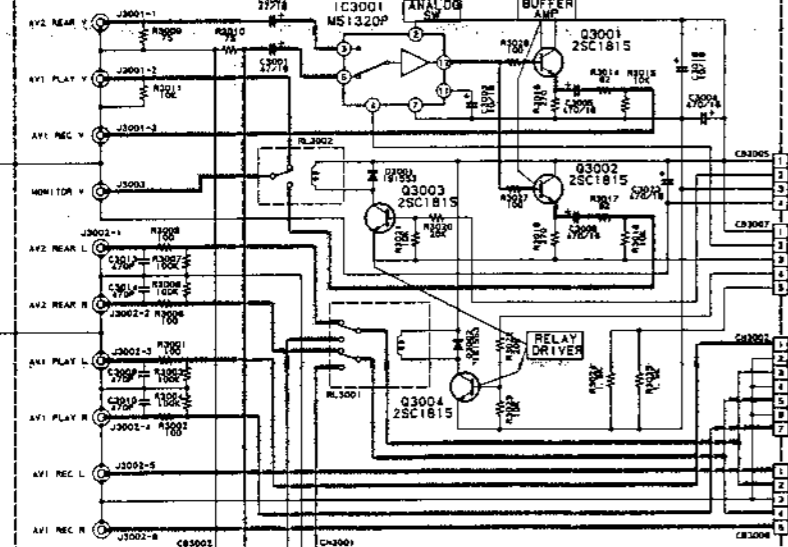

ADAPTER P. C. Board

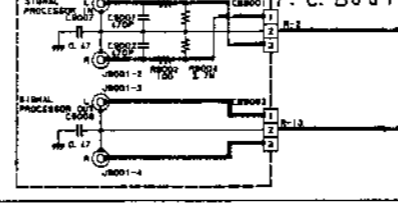

FUNCTION LED P. C. Board

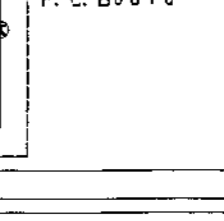

AV FRONT P. C. Board

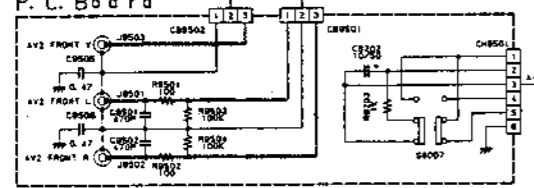

FUNCTION P. C. Board

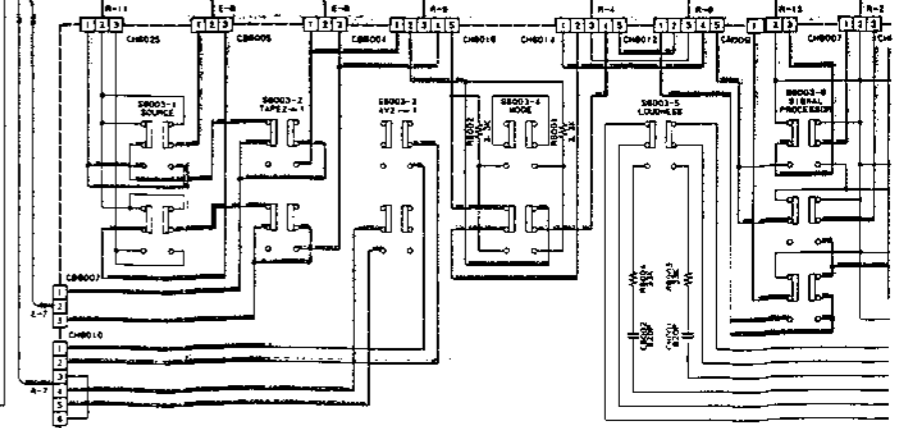
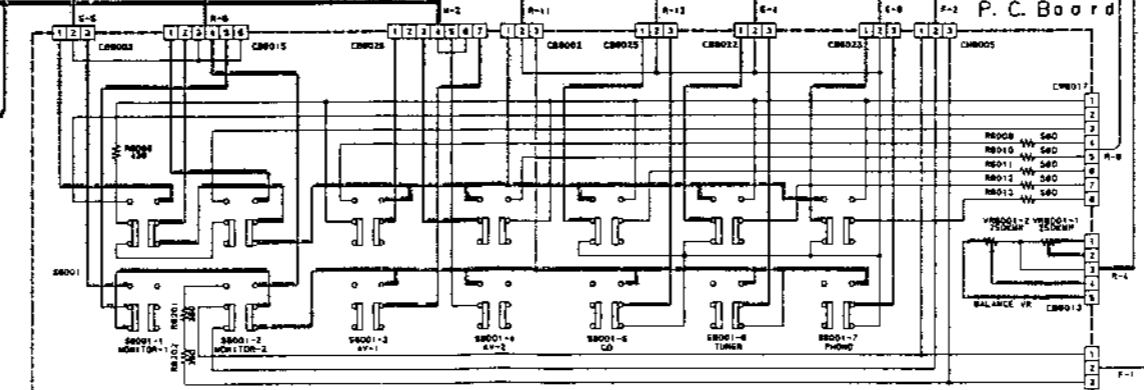

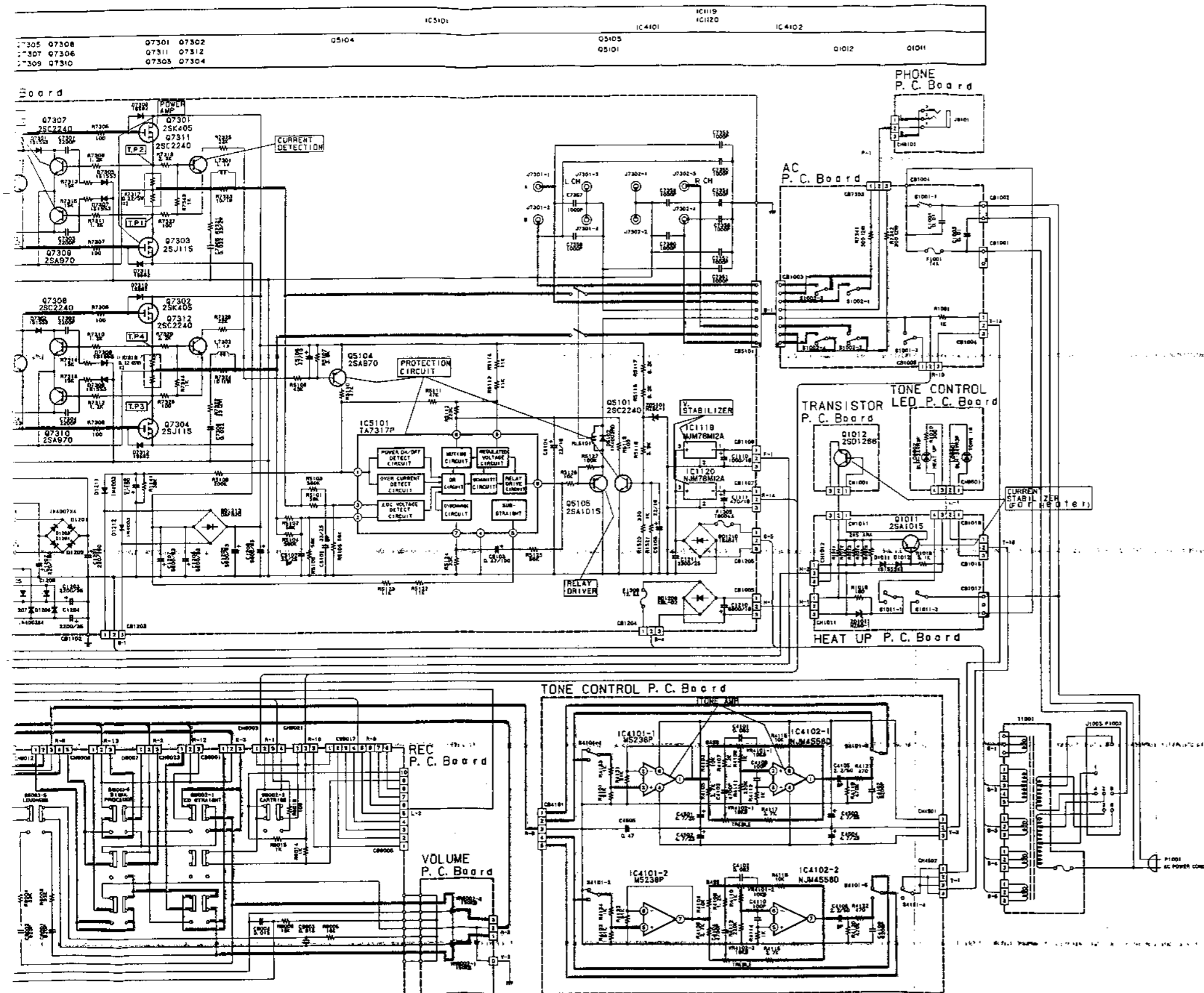

	C	B	E
Q1101	6.2V	7.1V	7.7V
Q1102	7.7V	6.2V	5.5V
Q1103	126V	100.5V	99.9V
Q1104	-126V	-100.5V	-99.9V
Q1105	0V	62.5V	63.1V
Q1106	0V	-62.5V	-63.1V
Q1107	62.5V	37.4V	36.8V
Q1108	-62.5V	-37.4V	-36.8V
Q1109	30.5V	22.6V	22V
Q1110	-30.5V	-22.6V	-22V
Q1111	0V	16.3V	16.9V
Q1112	0V	-16.3V	-16.9V
Q1113	17V	5.6V	5V
Q1114	-17V	-5.6V	-5V
Q1115	16.9V	5.6V	5V
Q1116	-16.9V	-5.6V	-5V
Q3001	12.1V	5.8V	5.1V
Q5002	12.1V	5.8V	5.1V
Q5003	0.1V	0.8V	0V
Q5004 (AV-1)	12.1V	0V	0V
Q5004 (Froot)	12.1V	0V	0V
Q5101	1.2V	0.3V	0V
Q5104	-0.1V	49.3V	49.3V
Q5105	0V	4.2V	3.6V
Q7103-1	-95V	-12.6V	-12V
Q7103-2	-95V	-12.6V	-12V
Q7104-1	-95V	-12.6V	-12V
Q7104-2	-95V	-12.6V	-12V
Q7105-1	-95V	-98.7V	-99.3V
Q7105-2	-98.7V	-98.7V	-99.3V
Q7106-1	-95V	-12.6V	-12V
Q7106-2	-98.7V	-98.7V	-99.3V
Q7107	30V	98.7V	99.3V
Q7108	30V	98.7V	99.3V
Q7109	-99.3V	-3V	-2.4V
Q7110	-99.3V	-3V	-2.4V
Q7805	2V	-1.6V	-2.4V
Q7806	2V	-1.6V	-2.4V
Q7807	2V	0V	0V
Q7808	2V	0V	0V
Q7809	-2.4V	0V	0V
Q7810	-2.4V	0V	0V
Q7811	49.3V	0V	0V
Q7812	49.3V	0V	0V

	D	C	S
Q1117	38.5V	5.6V	6.3V
Q1118	-5.6V	-30.5V	-29.8V
Q2101	10.6V	0V	0.2V
Q2102	10.6V	0V	0.2V
Q7101-1	-12V	0V	-0.3V
Q7101-2	-12V	0V	-0.3V
Q7102-1	-12V	0V	-0.3V
Q7102-2	-12V	0V	-0.3V
Q7301	49.3V	2V	0V
Q7302	49.3V	2V	0V
Q7303	-49.3V	-2.4V	0V
Q7304	-49.3V	-2.4V	0V

	P	G	K	P	G	K
Q4901	-3V	95V	-92V	-3V	-95V	-92V
Q4902	-3V	-95V	-92V	-3V	-95V	-92V

IC1119	
1	12.1V
2	0V
3	16.2V

IC5001	
1	—
2	12.1V
3	4.4V
4	17.1V
5	4.3V
6	—

IC4101	
1	0V
2	0V
3	0V
4	-14.4V
5	0V
6	0V
7	0V
8	14.4V

IC1120	
1	12.1V
2	0V
3	16.2V

IC2101	
1	0V
2	16.6V
3	10.6V
4	-22V
5	10.6V
6	10.6V
7	0V
8	22V

IC4102	
1	0V
2	0V
3	0V
4	-14.3V
5	0V
6	0V
7	0V
8	13.9V

IC5101	
1	-0.7V
2	0V
3	0V
4	0V
5	-0.6V
6	0.3V
7	0V
8	1.3V
9	3.1V

NOTES:
 1. All resistance values are in ohms. K = 1,000
 2. All capacitance values are in microfarads. P = $\frac{1}{1,000,000}$

Voltage Measuring Conditions
 • Power Supply Voltage: AC 220V
 • Measuring Meter: Digital Volt Meter
 • Measuring point reference: Between Ground
 • Measuring Conditions: No Signal Input

Parts Layout on P.C. Boards and Wiring Diagram

Note: In this diagram is (JM) for Japanese, (UN) for Canadian, (UL) for North American and (AM) for European model.

- | | |
|---------------|---------------------|
| BLU.....Blue | RED.....Red |
| GRN.....Green | YEL.....Yellow |
| BLK.....Black | VIO.....Violet |
| GRY.....Gray | BLK/WHT-Black/White |
| WHT.....White | SHLD.....Shield |

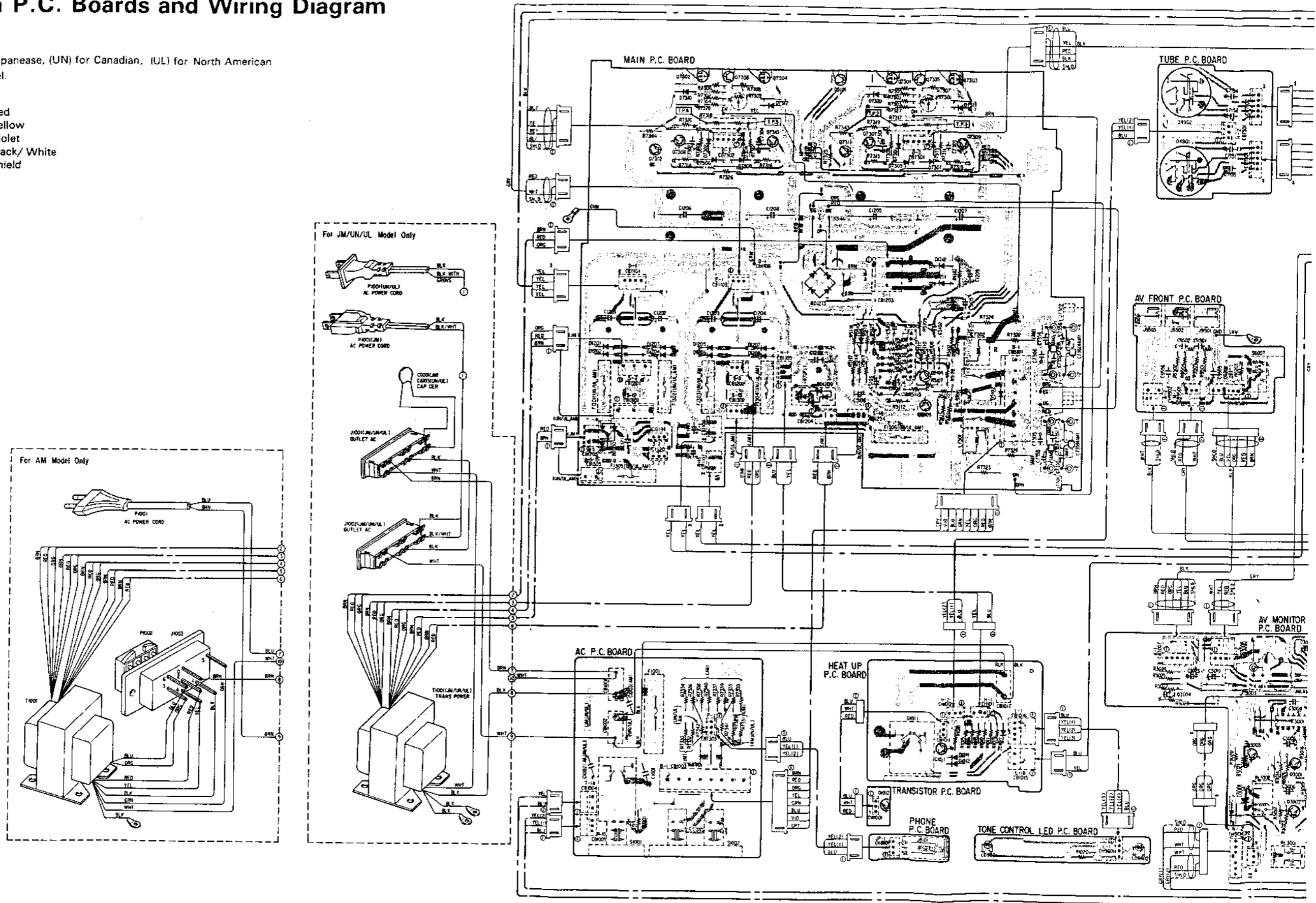

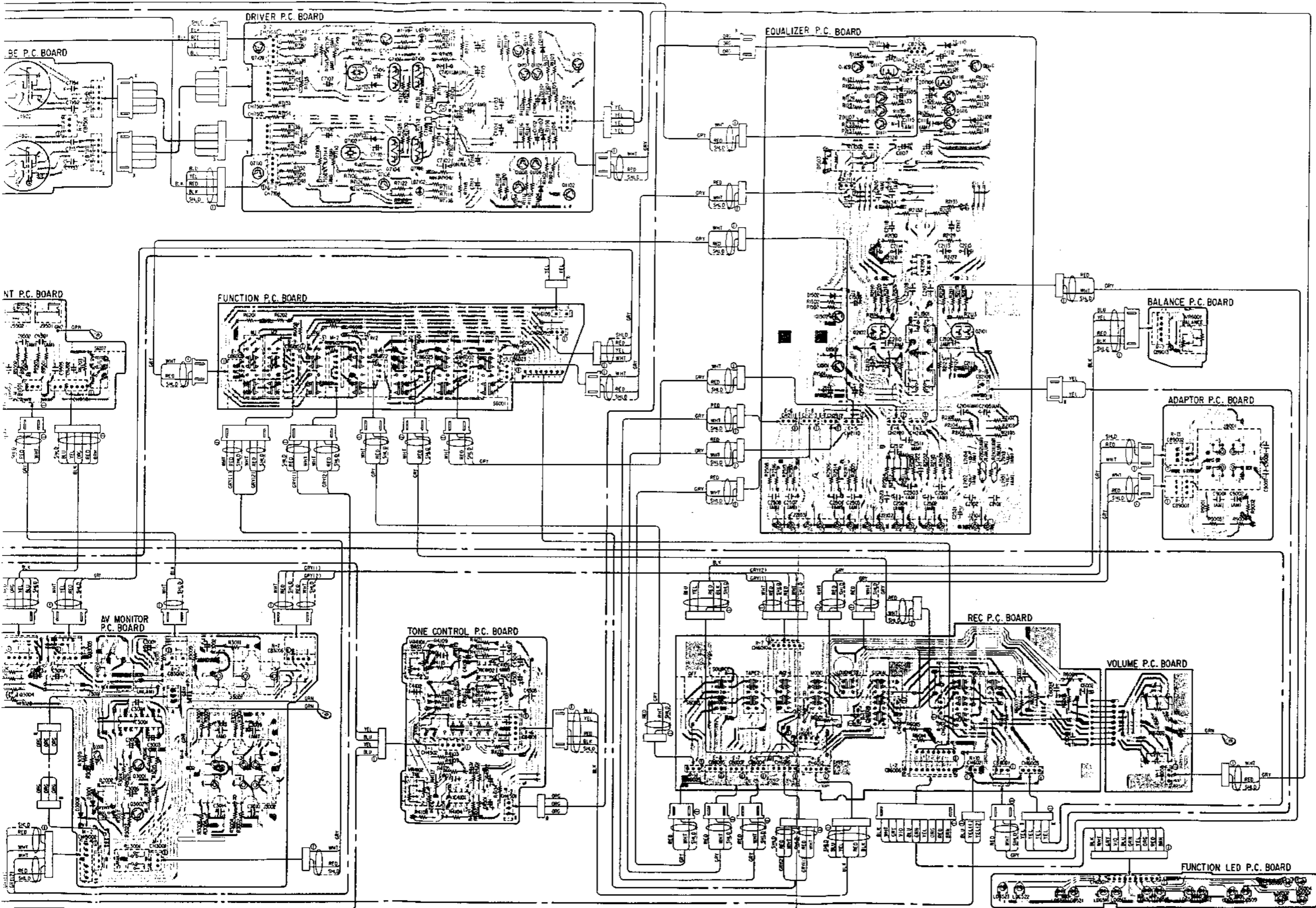

LV-103U LV-103U

• Abbreviation of Electrolytic Words

CAPACITOR	→	CAP
CARBON FILM	→	CF
CERAMIC	→	CER
CHIP	→	CP
CONNECTOR	→	CONN
ELECTROLYTIC	→	ELY
METAL FILM	→	MF
METAL OXIDE FILM	→	MO
METAL PLATE	→	MP
MYLAR	→	MYL
POLYPROPYLENE	→	PP
POLYSTYROL	→	POLY
RESISTOR	→	RES
TANTALUM	→	TAN
TRANSFORMER	→	TRANS
TRANSISTOR	→	TR

Electrical Parts List

Resistors: Carbon resistors under 1/4 watts are not mentioned in the parts list, please confirm them by schematic diagram.
 uF = microfarads, pF = picofarads

Symbol No.	Part No.	Description		
Main P.C.Board				
IC's				
IC1119	51T72375F01	NUM78M12A		
IC1120	51T72375F01	NUM78M12A		
IC6101	51T67437F01	TA7317P		
Transistors				
Q5104	48T52545F02	2SA970		
Q5105	48T81102F01	2SA1015		
Q7307	48T53301F02	2SC2240		
Q7308	48T53301F02	2SC2240		
Q7309	48T52545F02	2SA970		
Q7310	48T52545F02	2SA970		
Q7311	48T53301F02	2SC2240		
Q7312	48T53301F02	2SC2240		
Diodes				
D1201	48S40477U07	IN4007		
D1202	48S40477U07	IN4007		
D1203	48S40477U07	IN4007		
D1204	48S40477U07	IN4007		
D1205	48S40477U01	IN4003		
D1206	48S40477U01	IN4003		
D1207	48S40477U01	IN4003		
D1208	48S40477U01	IN4003		
D1211	48S40477U01	IN4003		
D1212	48S40477U01	IN4003		
D5102	48S40477U01	IN4003		
D7301	48T71195F01	1S1553		
D7302	48T71195F01	1S1553		
D7303	48T71195F01	1S1553		
D7304	48T71195F01	1S1553		
D7305	48T71195F01	1S1553		
D7306	48T71195F01	1S1553		
D7307	48T71195F01	1S1553		
D7308	48T71195F01	1S1553		
D7309	48T73079F02	1SS82TD		
D7310	48T73079F02	1SS82TD		
D7311	48T73079F02	1SS82TD		
D7312	48T73079F02	1SS82TD		
BD1209	48T71451F01	Bridge, KBL-02		
BD1210	48T61415F03	Bridge, 1G4B41		

Symbol No.	Part No.	Description		
BD1213	48T67435F01	Bridge, D5FB20		
* ZD5101	48T40150J25	Zener, HZ5C-1		
▲ ZD5101	48T52739F31	Zener, HZ5C-1		
■ ZD5101	48T62739F31	Zener, HZ5C-1		
Relay				
RL5101	80T53350F01	G2Z-222P-US		
Coils				
L7301	24T74614F01	Inductor, 1.1μH		
L7302	24T74614F01	Inductor, 1.1μH		
Jacks				
J7301-1 2 J7301-4	09T81893F02	Terminal, SP T5957L		
J7302-1 2 J7302-4	09T81893F01	Terminal, SP T5957		
Capacitors				
* C1110	23T00136L33	ELY 1000pF/16V		
▲ C1110	23T00137L49	ELY 1000pF/16V		
■ C1110	23T00137L49	ELY 1000pF/16V		
* C1111	23T00138L24	ELY 470pF/16V		
* C1201	23T00137L46	ELY 220pF/160V		
▲ C1201	23T00137L46	ELY 220pF/160V		
■ C1201	23T00137L46	ELY 220pF/160V		
* C1202	23T00137L45	ELY 220pF/160V		
▲ C1202	23T00137L45	ELY 220pF/160V		
■ C1202	23T00137L45	ELY 220pF/160V		
* C1203	23T00136L58	ELY 2200pF/35V		
▲ C1203	23T00137L47	ELY 2200pF/35V		
■ C1203	23T00137L47	ELY 2200pF/35V		
* C1204	23T00136L58	ELY 2200pF/35V		
▲ C1204	23T00137L47	ELY 2200pF/35V		
■ C1204	23T00137L47	ELY 2200pF/35V		
* C1205	23T00145L04	ELY 5800pF/63V		
C1206	23T00146L04	ELY 5600pF/63V		
C1207	23T00146L04	ELY 5800pF/63V		
C1208	23T00146L04	ELY 5800pF/63V		
C1209	23T00138L72	ELY 1pF/100V		
* C1210	23T00142L08	ELY 6800pF/16V		
▲ C1210	23T00142L38	ELY 6800pF/16V		

Note: * For Japanese model only (JM) ▲ For Canadian model only (UN)/North American model only (UL)
 ■ For European model only (AM) Others: Common

Symbol No.	Part No.	Description		
● C1210	23T00142L38	ELY 8800pF/18V		
● C1211	23T00137L44	ELY 3300pF/25V		
▲ C1211	23T00137L48	ELY 3300pF/25V		
● C1211	23T00137L48	ELY 3300pF/25V		
● C5101	23T00140L25	ELY 33pF/25V		
C5102	23T00140L25	ELY 33pF/25V		
C5103	23T00138L71	ELY 0.47pF/100V		
C5104	23T00138L18	ELY 22pF/16V		
C5105	23T00138L18	ELY 22pF/16V		
C5106	23T00138L11	ELY 47pF/10V		
C7301	08T52448F21	PP 2200pF		
C7302	08T52448F21	PP 2200pF		
C7303	08T52448F21	PP 2200pF		
C7304	08T52448F21	PP 2200pF		
C7305	08T52448F45	PP 0.022pF		
C7306	08T52448F45	PP 0.022pF		
■ C7351	08T57851F24	TF 1000pF		
■ C7352	08T57851F24	TF 1000pF		
■ C7353	08T57851F24	TF 1000pF		
■ C7354	08T57851F24	TF 1000pF		
■ C7355	08T57851F24	TF 1000pF		
■ C7356	08T57851F24	TF 1000pF		
■ C7357	08T50579F26	TF 1000pF		
■ C7358	08T50579F26	TF 1000pF		
■ C7359	08T50579F26	TF 1000pF		
● C7360	08T50579F26	TF 1000pF		
Resistors				
R7305	06T69013F41	Fuse, 100 Ohm 1/4W		
R7306	06T69013F41	Fuse, 100 Ohm 1/4W		
R7307	06T69013F41	Fuse, 100 Ohm 1/4W		
R7308	06T69013F41	Fuse, 100 Ohm 1/4W		
R7317	06T67397F01	MP 0.22 Ohm 5W		
R7318	06T67397F01	MP 0.22 Ohm 5W		
R7321	06T00007L29	MO 33 Ohm 2W		
R7322	06T00007L29	MO 33 Ohm 2W		
R7323	06T00008L17	MO 10 Ohm 1W		
R7324	06T00008L17	MO 10 Ohm 1W		
VR7301	18B44064J01	Variable 470 Ohm 1/2W		
VR7302	18B44064J01	Variable 470 Ohm 1/2W		
Equalizer P.C. Board				
IC				
IC2101	51T00038L01	M5220P		

Note: * For Japanese model only (JMJ) ▲ For Canadian model only (IUN)/North American model only (ULI)
 ■ For European model only (IAM) Others: Common

Symbol No.	Part No.	Description		
Transistors				
Q1108	48T64376F01	2SC3423		
Q1110	48T64375F01	2SA1360		
Q1111	48T81102F01	2SA1015		
Q1112	48T81101F01	2SC1815		
Q1113	48T81101F01	2SC1815		
Q1114	48T81102F01	2SA1015		
Q1115	48T81101F01	2SC1815		
Q1116	48T81102F01	2SA1015		
Q1117	48T52152F01	2SK30A		
Q1118	48T52152F01	2SK30A		
Q1501	48T81101F01	2SC1815		
Q1502	48T81101F01	2SC1815		
Q2101	48T72887F02	2SK332		
Q2102	48T72887F02	2SK332		
Diodes				
D1501	48S40477J01	1N4003		
D1502	48T71195F01	1S1553		
D1503	48S40477J01	1N4003		
ZD1105	48T52741F03	Zener, HZ6A-3L		
ZD1106	48T52741F03	Zener, HZ6A-3L		
ZD1107	48T52741F03	Zener, HZ6A-3L		
ZD1108	48T52741F03	Zener, HZ6A-3L		
ZD1110	48T52741F51	Zener, HZ16-3L		
ZD1111	48T52741F51	Zener, HZ16-3L		
Inductors				
● L2101	24T83130F02	Coil, 33pH		
● L2102	24T83130F02	Coil, 33pH		
● L2103	24T83130F02	Coil, 33pH		
● L2104	24T83130F02	Coil, 33pH		
Capacitors				
C1105	23T00138L49	ELY 10pF/50V		
C1106	23T00138L49	ELY 10pF/50V		
C1107	23T00138L52	ELY 47pF/50V		
C1108	23T00138L52	ELY 47pF/50V		
C1112	23T00138L49	ELY 10pF/50V		
C1113	23T00138L49	ELY 10pF/50V		
C1114	08T57851F21	TF 0.47pF		

Symbol No.	Part No.	Description		
● C1115	08T81196F34	CER 100pF		
● C1116	08T81196F34	CER 100pF		
● C1501	23T00138L22	ELY 220pF/16V		
▲ C1501	23T00138L21	ELY 100pF/16V		
▲ C1501	23T00138L22	ELY 220pF/16V		
C1502	23T00138L24	ELY 470pF/16V		
C1503	23T00138L19	ELY 33pF/16V		
C2101	08T81196F34	Mica 100pF		
C2102	08T81196F34	Mica 100pF		
■ C2103	08T55119F42	Mica 220pF		
■ C2104	08T55119F42	Mica 220pF		
C2107	08T52448F25	PP 3300pF		
C2108	08T52448F25	PP 3300pF		
● C2109	21S40655F20	CER 56pF		
● C2110	21S40655F20	CER 56pF		
C2111	23T00153L01	ELY 1000pF/6.3V		
C2112	23T00153L01	ELY 1000pF/6.3V		
C2113	08T52448F36	PP 9100pF		
C2114	08T52448F36	PP 9100pF		
C2115	08T71458F39	PP 0.0318pF		
C2116	08T71458F39	PP 0.0318pF		
C2117	23T00140L39	ELY 4.7pF/50V (BP)		
C2118	23T00140L39	ELY 4.7pF/50V (BP)		
■ C2119	08T57851F29	TF 2700pF		
■ C2120	08T57851F29	TF 2700pF		
■ C2501	08S40805F05	CER 470pF		
■ C2502	08S40805F05	CER 470pF		
■ C2503	08S40805F05	CER 470pF		
■ C2504	08S40805F05	CER 470pF		
■ C2505	08S40805F05	CER 470pF		
■ C2506	08S40805F05	CER 470pF		
■ C2507	08S40805F05	CER 470pF		
■ C2508	08S40805F05	CER 470pF		
■ C2511	08S40805F05	CER 470pF		
■ C2512	08S40805F05	CER 470pF		
● C2521	08T57851F21	TF 0.47pF		
▲ C2521	08T57851F21	TF 0.47pF		
▲ C2521	08T57851F24	TF 1000pF		
C2522	08T57851F21	TF 0.47pF		
C2523	08T57851F21	TF 0.47pF		
Relays				
● RL1501	80T72831F01	G8A-434P-12VDC		
● RL1502	80T00048L01	RZ-12W		
▲ RL1502	80T83717F02	DS2Y-S-DC12V		

Note: * For Japanese model only (JMJ) ▲ For Canadian model only (IUN)/North American model only (ULI)
 ■ For European model only (IAM) Others: Common

Symbol No.	Part No.	Description		
● RL1502	80T83717F02	DS2Y-S-DC12V		
Jacks				
J2101-1 2	09T81363F01	Plate, Phone (Phone)		
J2101-2				
J2102-1 2	09T81364F01	Plate, Phone (CD, Tuner)		
J2102-4				
J2103-1 2	09T81364F01	Plate, Phone (Tape 1, Tape 2)		
J2103-6				
Driver P.C. Board				
Transistors				
Q1101	48T62642F01	2SC2336		
Q1102	48T62641F01	2SA1006		
Q1103	48T64375F01	2SA1360		
Q1104	48T64376F01	2SC3423		
Q1105	48T64376F01	2SC3423		
Q1106	48T64376F01	2SA1360		
Q1107	48T64376F01	2SC3423		
Q1108	48T64375F01	2SA1360		
Q7101	48T62284F02	FET, 2SJ75		
Q7102	48T62284F02	FET, 2SJ75		
Q7103	48T72597F01	2SA995		
Q7104	48T72597F01	2SA995		
Q7105	48T72598F01	2SC2291		
Q7106	48T72598F01	2SC2291		
Q7107	48T64375F01	2SA1360		
Q7108	48T64375F01	2SA1360		
Q7109	48T71448F01	2SA1361		
Q7110	48T71448F01	2SA1361		
Diodes/LEDs				
ZD1101	48T52741F74	Zener, HZ36-2L		
ZD1102	48T52741F74	Zener, HZ36-2L		
ZD1103	48T52741F74	Zener, HZ36-2L		
ZD1104	48T52741F74	Zener, HZ36-2L		
ZD7101	48T52741F38	Zener, HZ12A-2L		
ZD7102	48T52741F38	Zener, HZ12A-2L		
LD7101	48T52953F03	LED, BR5507S (RED)		
LD7102	48T52953F03	LED, BR5507S (RED)		

Symbol No.	Part No.	Description		
Capacitors				
C1101	23T00138L49	ELY 10 μ F/50V		
C1102	23T00138L49	ELY 10 μ F/50V		
C1103	23T00138L86	ELY 10 μ F/160V		
C1104	23T00138L86	ELY 10 μ F/160V		
C1151	08T81198F42	Mica 220pF		
C7105	08T81642F12	Mica 22pF		
C7106	08T81642F12	Mica 22pF		
C7101	08T81198F34	Mica 100pF		
C7101	08T81198F34	Mica 100pF		
C7102	08T81198F34	Mica 100pF		
C7102	08T81198F34	Mica 100pF		
C7107	23T00140L39	ELY 4.7 μ F/50VBP		
C7108	23T00140L39	ELY 4.7 μ F/50VBP		
C7109	23T00138L20	ELY 47 μ F/16V		
C7110	23T00138L20	ELY 47 μ F/16V		
C7113	23T00138L85	ELY 4.7 μ F/160V		
C7114	23T00138L85	ELY 4.7 μ F/160V		
C7115	23T00138L85	ELY 4.7 μ F/160V		
C7116	23T00138L85	ELY 4.7 μ F/160V		
C7117	08T81642F31	Mica 150pF		
C7118	08T81642F31	Mica 150pF		
Resistors				
R7134	08T89013F41	Fuse, 100 Ohm 1/4W		
R7154	08T89013F41	Fuse, 100 Ohm 1/4W		
AV Monitor P.C Board				
IC				
IC3001	51T80995F01	M51320P		
Capacitors				
C3001	23S57007F15	ELY 47 μ F/16V		
C3002	23S57007F15	ELY 47 μ F/16V		
C3003	23S57007F09	ELY 10 μ F/16V		
C3004	23S40657F62	ELY 470 μ F/16V		
C3005	23S40657F62	ELY 470 μ F/16V		
C3006	23S40657F62	ELY 470 μ F/16V		
C3008	08S40805F05	CER 470pF		
C3010	08S40805F05	CER 470pF		
C3013	08S40805F05	CER 470pF		

Note *: For Japanese model only (JM) * : For Canadian model only (IUN)/North American model only (IUL)
 ■ : For European model only (IAM) Others: Common

Symbol No.	Part No.	Description		
C3014	08S40805F05	CER 470pF		
C3019	23S57007F09	ELY 10 μ F/16V		
C3023	23S40657F62	ELY 470 μ F/16V		
Transistors				
Q3001	48S43525F03	2SC1815		
Q3001	48T81101F01	2SC1815		
Q3001	48T81101F01	2SC1815		
Q3002	48S43525F03	2SC1815		
Q3002	48T81101F01	2SC1815		
Q3002	48T81101F01	2SC1815		
Q3002	48T81101F01	2SC1815		
Q3002	48T81101F01	2SC1815		
Q3003	48S43525F03	2SC1815		
Q3003	48T81101F01	2SC1815		
Q3003	48T81101F01	2SC1815		
Q3003	48T81101F01	2SC1815		
Q3004	48S43525F03	2SC1815		
Q3004	48T81101F01	2SC1815		
Q3004	48S43525F05	2SC1815		
Diodes				
D3001	48T71195F01	1S1553		
D3002	48T71195F01	1S1553		
Relays				
RL3001	80T73904F02	FBR42NGD12-P		
RL3002	80T82335F01	G2E-1645A		
Jacks				
J3001-1)	09T81368F01	Plate, Phone (AV-1, -2)		
J3001-3)	09T81368F01	Plate, Phone (AV-1, -2)		
J3002-1)	09T81367F01	Plate, Phone (AV-1, -2)		
J3002-6)	09T81370F01	Plate, Phone (Monitor)		
J3003	09T81370F01	Plate, Phone (Monitor)		
Tone Control P.C Board				
IC's				
IC4101	51T80130F01	M5238P		
IC4102	51T52383F01	NJM4558D		

Symbol No.	Part No.	Description		
Switch				
S4101-1)	40T81347F01	Push, SUL 122A (TONE)		
S4101-5)				
Capacitors				
C4101	08T57851F12	TF 0.082 μ F		
C4102	08T57851F12	TF 0.082 μ F		
C4103	08T52448F28	PP 4700pF		
C4104	08T52448F29	PP 4700pF		
C4105	23T00140L37	ELY 2.2 μ F/50V (BP)		
C4106	23T00140L37	ELY 2.2 μ F/50V (BP)		
C4107	08T52448F35	PP 8200pF		
C4108	08T52448F35	PP 8200pF		
C4109	08T81642F27	Mica 100pF		
C4110	08T81642F27	Mica 100pF		
C4501	23T00138L28	ELY 4.7 μ F/25V		
C4502	23T00138L28	ELY 4.7 μ F/25V		
C4503	23T00138L28	ELY 4.7 μ F/25V		
C4504	23T00138L28	ELY 4.7 μ F/25V		
C4505	08T57851F21	TF 0.47 μ F		
Volume				
VR4101	18T67394F01	Control 10KB x 2 (BASS)		
VR4102	18T67394F01	Control 10KB x 2 (TREBLE)		
REC P.C Board				
Switches				
S6002	40T82248F01	Push, SPEC2 (CD STRAIGHT, CARTRIDGE)		
S6003	40T81349F01	Push, SPEC7 (SOURCE, TAPE2 → 1, AV2 → 1 MODE, LOUD, SIGNAL PROCESSOR)		
Capacitors				
C6001	08T52448F11	PP 820pF		
C6002	08T52448F11	PP 820pF		
C6003	08T52448F41	PP 0.015 μ F		

Note *: For Japanese model only (JM) * : For Canadian model only (IUN)/North American model only (IUL)
 ■ : For European model only (IAM) Others: Common

Symbol No.	Part No.	Description		
C6003	08T57851F03	PP 0.015 μ F		
C6003	08T57851F03	PP 0.015 μ F		
C6004	08T52448F41	PP 0.015 μ F		
C6004	08T57851F03	PP 0.015 μ F		
C6004	08T57851F03	PP 0.015 μ F		
Function P.C. Board				
Switch				
S6001-1)	40T81348F01	Push, SUL 702A (MONITOR-1, 2, AV-1, 2, CD, TUNER, PHONE)		
S6001-2)				
S6001-3)				
Function LED P.C. Board				
LEDs				
LD6501	48T60947F04	SLH-34MG3F (GRN)		
LD6502	48T60947F04	SLH-34MG3F (GRN)		
LD6504	48T60947F05	SLH-34VR3F (RED)		
LD6508	48T60947F05	SLH-34VR3F (RED)		
LD6507	48T60947F04	SLH-34MG3F (GRN)		
LD6509	48T60947F04	SLH-34MG3F (GRN)		
LD6510	48T60947F04	SLH-34MG3F (GRN)		
LD6512	48T60947F04	SLH-34MG3F (GRN)		
LD6513	48T60947F04	SLH-34MG3F (GRN)		
LD6515	48T60947F04	SLH-34MG3F (GRN)		
LD6516	48T60947F04	SLH-34MG3F (GRN)		
LD6517	48T60947F04	SLH-34MG3F (GRN)		
LD6519	48T60947F04	SLH-34MG3F (GRN)		
LD6521	48T60947F04	SLH-34MG3F (GRN)		
LD6522	48T60947F05	SLH-34VR3F (RED)		
LD6523	48T60947F05	SLH-34VR3F (RED)		
AV Front P.C. Board				
Switch				
S6007	40T81348F01	Push, SUL 121A (AV-2)		

Symbol No.	Part No.	Description		
Jacks				
J9501	09T67396F01	Plate, PH 573-01-510		
J9502	09T67396F01	Plate, PH 573-01-510		
J9503	09T67396F01	Plate, PH 573-01-510		
Capacitors				
C6202	23T00138L49	ELY 10 μ F/50V		
C9501	08S40805F05	CER 470pF		
C9502	08S40805F05	CER 470pF		
C9505	08T57851F21	TF 0.47 μ F		
C9506	08T57851F21	TF 0.47 μ F		
Heat-up P.C. Board				
Transistor				
Q1011	48T81102F01	2SA1016		
Diodes				
D1011	48T71195F01	151553		
D1012	48T71195F01	151553		
ZD1011	48T52739F31	Zener, 1/2 5C-1		
Switches				
* S1011-1	40T81345F01	Push, SDS 2.5		
-2				
▲ S1011-1	40T83286F01	Push, SDS 2.5		
-2				
■ S1011-1	40T81345F01	Push, SDS 2.5 (PRE-HEATING)		
-2				
AC P.C. Board				
Switches				
* S1001-1	40T81983F02	Push, SDU 3P		
2				
S1001-3				
▲ S1001-1	40T81983F02	Push, SDU 3P		
2				
S1001-3				
■ S1001-1	40T81983F02	Push, SDU 3P (POWER)		
2				
S1001-3				
S1002-1	40T67388F01	Push, SUL 231A (SPEAKER A,B)		
2				
S1002-4				

Note: * : For Japanese model only (JM) ▲ : For Canadian model only (UN)/North American model only (UL)
 ■ : For European model only (EM) Others: Common

Symbol No.	Part No.	Description		
Capacitors				
C1001	08T57437F11	CER 0.01 μ F		
* C1002	08T57437F11	CER 0.01 μ F		
▲ C1002	08T57437F11	CER 0.01 μ F		
■ C1003	08T57437F11	CER 0.01 μ F		
Resistors				
▲ R7341	06T00007L52	MO 200 2W		
■ R7341	06T00007L52	MO 300 2W		
▲ R7342	06T00007L52	MO 300 2W		
■ R7342	06T00007L52	MO 300 2W		
Adapter P.C. Board				
Jacks				
J901-1	09T81385F01	Plate, Phone (Signal Processor)		
2				
J901-4				
Capacitors				
■ C9001	08S40805F05	CER 470pF		
■ C9002	08S40805F05	CER 470pF		
C9007	08T57851F21	TF 0.47 μ F		
C9008	08T57851F21	TF 0.47 μ F		
Tube P.C. Board				
Capacitors				
C7151	08T81196F03	Mica, 3pF		
C7152	08T81196F03	Mica, 3pF		
C7153	08T81196F03	Mica, 3pF		
C7154	08T81196F03	Mica, 3pF		
Miscellaneous				
* C0001	08T57437F11	CAP, CER 0.01 μ F		
▲ C0001	08T57437F11	CAP, CER 0.01 μ F		
* F1001	65T55050F18	Fuse, NR60 7A-125V		
▲ F1001	65T85292F02	Fuse, GGL 7A-250V		

Symbol No.	Part No.	Description		
* F1001	65T42077U22	Fuse, Semko T-4A		
▲ F1301	65T86926F14	Fuse, 51NM 1.25A-125V		
■ F1301	65T42077U08	Fuse, Semko T-160mA		
▲ F1302	65T86926F14	Fuse, 51NM 1.25A-125V		
■ F1302	65T42077U08	Fuse, Semko T-160mA		
▲ F1303	65T86926F15	Fuse, 51NM 1.6A-125V		
■ F1303	65T42077U08	Fuse, Semko T-160mA		
▲ F1304	65T86926F15	Fuse, 51NM 1.6A-125V		
■ F1304	65T42077U08	Fuse, Semko T-160mA		
▲ F1305	65T86926F15	Fuse, 51NM 1.6A-125V		
■ F1305	65T42077U15	Fuse, Semko T-600mA		
▲ F1306	65T86926F18	Fuse, 51NM 3.15A-125V		
■ F1306	65T42077U20	Fuse, Semko T-2.5A		
* J1001	09T67405F02	Outlet, AC		
▲ J1001	09T67405F02	Outlet, AC		
* J1002	09T67405F02	Outlet, AC		
▲ J1002	09T67405F02	Outlet, AC		
■ J1003	09T51831F01	Socket Switch M-1615		
J8101	09T86672F01	Jack, Headphone		
LD8601	48T80947F05	LED, SLH-34VR3F (RED)		
LD9602	48T80947F05	LED, SLH-34VR3F (RED)		
* P1001	28T67434F01	AC Power Cord (12A)		
▲ P1001	28T55335F02	AC Power Cord (12A)		
■ P1001	28T43812P05	AC Power Cord (12A)		
■ P1002	08T51830F01	Plug, Switch P-2120		
Q1012	48T56031F01	TR, 2SD1266		
* Q4901	65T00091L03	Vacuum Tube (6CG7)		
▲ Q4901	65T00091L01	Vacuum Tube (6CG7)		
■ Q4901	65T00091L01	Vacuum Tube (6CG7)		
* Q4902	65T00091L03	Vacuum Tube (6CG7)		
▲ Q4902	65T00091L01	Vacuum Tube (6CG7)		
■ Q4902	65T00091L01	Vacuum Tube (6CG7)		
Q5101	48T53301F02	TR, 2SC3423		
Q7301	48T67399F03	FET, 2SK405		
Q7302	48T67399F03	FET, 2SK405		
Q7303	48T67399F03	FET, 2SJ115		
Q7304	48T67399F03	FET, 2SJ115		
Q7305	48T64376F01	TR, 2SC3423		
Q7306	48T64376F01	TR, 2SC3423		
* T1001	25T81357F01	Trans, Power		
▲ T1001	25T81357F03	Trans, Power		
■ T1001	25T81357F02	Trans, Power		
VR6001-1	18T82249F01	Volume Control 250K (Balance)		
2				
VR6001-2				
VR6002-1	18T71727F02	Volume Control 150K \times 2		
2				
VR6002-2				

Note: * : For Japanese model only (JM) ▲ : For Canadian model only (UN)/North America model only (UL)
 ■ : For European model only (EM) Others: Common

Parts List by the Destination

Sym- bol No.	Description	POWER SOURCE		
		JM# 100V	UN/UL# 120V	AM# 220V
		Japanese	Canadian/North American	European
C0001	CAP	08T57437F11	08T57437F11	Not Used
C1002	CAP	08T57437F11	08T57437F11	Not Used
C1003	CAP	Not Used	Not Used	08T57437F11
C1110	CAP	23T00138L33	23T00137L49	23T00137L49
C1115	CAP	Not Used	Not Used	08T81196F34
C1116	CAP	Not Used	Not Used	08T81196F34
C1151	CAP	Not Used	Not Used	08T81196F42
C1201	CAP	23T00137L45	23T00137L46	23T00137L46
C1202	CAP	23T00137L45	23T00137L46	23T00137L46
C1203	CAP	23T00138L58	23T00137L47	23T00137L47
C1204	CAP	23T00138L58	23T00137L47	23T00137L47
C1210	CAP	23T00142L08	23T00142L38	23T00142L38
C1211	CAP	23T00137L44	23T00137L48	23T00137L48
C1501	CAP	23T00138L22	23T00138L21	23T00138L22
C2103	CAP	Not Used	Not Used	08T55119F42
C2104	CAP	Not Used	Not Used	08T55119F42
C2109	CAP	Not Used	Not Used	21S40655F20
C2110	CAP	Not Used	Not Used	21S40655F20
C2119	CAP	Not Used	Not Used	08T57851F29
C2120	CAP	Not Used	Not Used	08T57851F29
C2501	CAP	Not Used	Not Used	08S40805F05
C2502	CAP	Not Used	Not Used	08S40805F05
C2503	CAP	Not Used	Not Used	08S40805F05
C2504	CAP	Not Used	Not Used	08S40805F05
C2505	CAP	Not Used	Not Used	08S40805F05
C2506	CAP	Not Used	Not Used	08S40805F05
C2507	CAP	Not Used	Not Used	08S40805F05
C2508	CAP	Not Used	Not Used	08S40805F05
C2511	CAP	Not Used	Not Used	08S40805F05
C2512	CAP	Not Used	Not Used	08S40805F05
C2521	CAP	08T57851F21	08T57851F21	08T57851F24
C3009	CAP	Not Used	Not Used	08S40805F05
C3010	CAP	Not Used	Not Used	08S40805F05
C3013	CAP	Not Used	Not Used	08S40805F05
C3014	CAP	Not Used	Not Used	08S40805F05
C4109	CAP	Not Used	Not Used	08T61642F27
C4110	CAP	Not Used	Not Used	08T61642F27
C6003	CAP	08T52448F41	08T57851F03	08T57851F03
C6004	CAP	08T52448F41	08T57851F03	08T57851F03
C7101	CAP	08T81196F34	08T8119F34	Not Used
C7102	CAP	08T81196F34	08T8119F34	Not Used
C7105	CAP	Not Used	Not Used	08T61642F12
C7106	CAP	Not Used	Not Used	08T61642F12
C7117	CAP	Not Used	Not Used	08T61642F31
C7118	CAP	Not Used	Not Used	08T61642F31

Note: * : For Japanese model only (JM) * : For Canadian model only (UN)/North American model only (UL)

* : For European model only (AM) Others: Common 36

Sym- bol No.	Description	POWER SOURCE		
		JM# 100V	UN/UL# 120V	AM# 220V
		Japanese	Canadian/North America	European
C7351	CAP	Not Used	Not Used	08T57851F24
C7352	CAP	Not Used	Not Used	08T57851F24
C7353	CAP	Not Used	Not Used	08T57851F24
C7354	CAP	Not Used	Not Used	08T57851F24
C7355	CAP	Not Used	Not Used	08T57851F24
C7356	CAP	Not Used	Not Used	08T57851F24
C7357	CAP	Not Used	Not Used	08T50579F26
C7358	CAP	Not Used	Not Used	08T50579F26
C7359	CAP	Not Used	Not Used	08T50579F26
C7360	CAP	Not Used	Not Used	08T50579F26
C9001	CAP	Not Used	Not Used	08S40805F05
C9002	CAP	Not Used	Not Used	08S40805F05
C9501	CAP	Not Used	Not Used	08S40805F05
C9502	CAP	Not Used	Not Used	08S40805F05
F1001	Fuse	65T55050F18	65T65292F02	65T42077U22
F1301	Fuse	Not Used	65T66926F14	65T42077U08
F1302	Fuse	Not Used	65T66926F14	65T42077U08
F1303	Fuse	Not Used	65T66926F15	65T42077U08
F1304	Fuse	Not Used	65T66926F15	65T42077U08
F1305	Fuse	Not Used	65T66926F15	65T42077U15
F1306	Fuse	Not Used	65T66926F18	65T42077U20
J1001	Outlet, AC	09T67405F02	09T67405F02	Not Used
J1002	Outlet, AC	09T67406F02	09T67405F02	Not Used
J1003	Socket, Switch	Not Used	Not Used	09T51831F01
L2101	Inductor	Not Used	Not Used	24T83130F02
L2102	Inductor	Not Used	Not Used	24T83130F02
L2103	Inductor	Not Used	Not Used	24T83130F02
L2104	Inductor	Not Used	Not Used	24T83130F02
P1001	AC Power Cord	28T67434F01	28T56335F02	28T43812P05
P1002	Plug, Switch	Not Used	Not Used	05T51830F01
Q3001	TR	48S43525F03	48T81101F01	48T81101F01
Q3002	TR	48S43525F03	48T81101F01	48T81101F01
Q3003	TR	48S43525F03	48T81101F01	48T81101F01
Q3004	TR	48S43525F03	48T81101F01	48S43525F05
Q4901	Vacuum Tube	65T00091L03	65T00091L01	65T00091L01
Q4902	Vacuum Tube	65T00091L03	65T00091L01	65T00091L01
R7341	RES	Not Used	06T00007L52	06T00007L52
R7342	RES	Not Used	06T00007L52	06T00007L52
RL1502	Reray	80T00048L01	80T83717F02	80T83717F02
S1001	Switch	40T61963F02	40T61963F02	40T68579F01
S1011	Switch	40T81345F01	40T83288F01	40T81345F01
T1001	Trans. Power	25T81357F01	25T81357F03	25T81357F02
ZD5101	Diode, Zener	48T40150U25	48T52739F31	48T52739F31
13	Cover, Rear	15C81265F02	15C81265F08	15C81265F04
18	Label, Fuse	54B62266F01	54B62266F52	54B62266F54

Note: * : For Japanese model only (JM) * : For Canadian model only (UN)/North American model only (UL)

* : For European model only (AM) Others: Common 37

Sym- bol No.	Description	POWER SOURCE		
		JM● 100V	UN/UL▲ 120V	AM■ 220V
		Japanese	Canadian/North American	European
27	Holder, Fuse	09T51960F01	09T51960F01	Not Used
64	Assembly, Front Panel	01V81800F24	01V83600F92	01V83600F92
73	Bush, Cap	43T53136F01	43T53136F01	Not Used
79	Label, Fuse	Not Used	54B62266F49	Not Used
80	Label, Fuse	Not Used	54B62266F50	Not Used
81	Label, Fuse	Not Used	54B62266F51	Not Used
82	Holder, Fuse	Not Used	09T45548F01	09T45548F01
101	Owners Manual	68P80130F58	68P81707F58	68P80707F59
103	Carton, Packing	56S71001F75	56S71001F89	56S71001F89

Note: * : For Japanese model only (JM) ▲ : For Canadian model only (UN)/North American model (UL)
 ● : For European model only (AM) Others: Common

Packing Method View

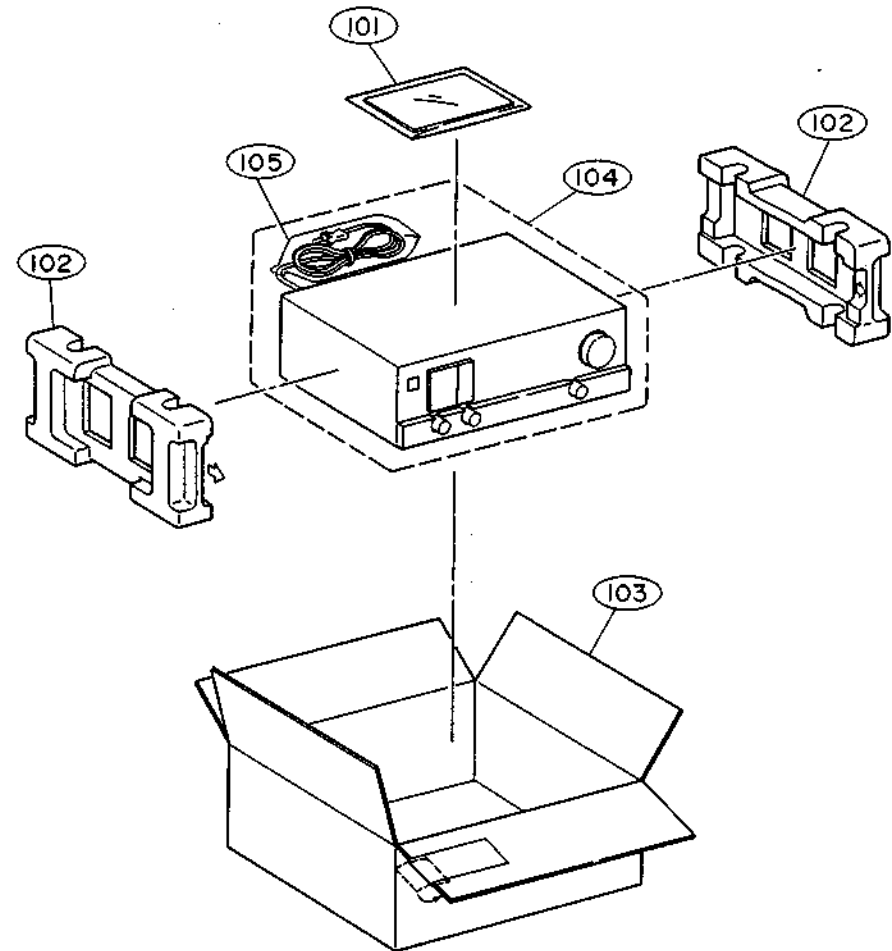

Packing Assembly Parts List

Symbol No.	Part No.	Description		
* 101	68P80130F58	Owners, Manual		
▲ 101	68P81707F58	Owners, Manual		
■ 101	68P80707F59	Owners, Manual		
102	56D67465F01	Packing, Tray		
■ 103	56S71001F75	Carton, Packing		

Symbol No.	Part No.	Description		
▲ 103	56S71001F89	Carton, Packing		
■ 103	56S71001F89	Carton, Packing		
104	56B40442T17	Packing, Front Frame		
105	56B40230G08	Sack, Polyethylene		

Note: * : For Japanese model only (JM) ▲ : For Canadian model only (UN)/North American model only (UL)
 ■ : For European model only (AM) Others: Common

Cabinet Assembly Parts List

Note: The parts without part number are not supplied.

Symbol No.	Index	Part No.	Description			Symbol No.	Index	Part No.	Description		
1	5-A	01B81332F01	Assy., Escutcheon, Knob			48		03S40018G08	Screw, Tapping (M3 x 8)		
3	2-A	15D67323F01	Cover, Top			51	2-G	07R51148F01	Support, Tr.		
5		36A67337F01	Knob, Tone Volume			53	3-E	75A67341F01	Cushion, Tube		
7	3-B	36A67330F01	Knob, Power			58	5-A	41A88570F01	Spring, Volume		
8	3-B	36A67331F01	Knob, Push (SPI)			59	4-H	75A82703F01	Cushion, Rubber		
9	4-C	36A81266F01	Knob, Push (SPI)			60	3-B	03S71031F05	Screw, Countersink (M3 x 8)		
10		36A67333F01	Knob, Push (SPI)			62		29A41814G01	Lug		
11	4-C	36A67334F01	Knob, Push (AV)			63		75A67063F03	Trans-Leg		
12	4-B	36B67336F01	Knob, Main Volume			64	3-A	01V81600F24	Assy., Front Panel		
13	2-H	15C81265F02	Cover, Rear			64	3-A	01V83600F92	Assy., Front Panel		
13	2-H	15C81265F06	Cover, Rear			64	3-A	01V83600F92	Assy., Front Panel		
14	4-C	43A67342F01	Spacer, Switch			66		29C41045P06	Lug, Board-In 50 mm		
15	3-F	03C40121T18	Screw, W/Double Washer (M3 x 10)			68	2-D	09T64527F02	Socket, Tube 9 Pin		
17	2-E	07C67318F01	Frame, Tube			69	1-H	29T66964F01	Terminal GND		
18	3-C	54B62266F01	Label, Fuse 7A-125V			70	3-B	14S81481F12	Insulator, Cover		
18	3-C	54B62266F52	Label, Fuse 7A-125V			73	1-F	43T53136F01	Bush, Cap		
18	3-C	54B62266F54	Label, Fuse 7A-125V			73	1-F	43T53136F01	Bush, Cap		
19		03A82468F01	Screw, Bind (M3 x 10)			74	1-F	43B41625J02	Support Cord		
20	3-C	03D40014G04	Screw, W/Washer (M3 x 8)			77	3-F	14A63125F01	Insulator, SP Terminal "B"		
21		03S71031F04	Screw, Bind (M3 x 8)			78	4-E	84D81371F09	Panel, AV Front Hold		
22	2-F	75A82303F01	Cushion, Rubber			79	4-E	54B62266F49	Label, Fuse		
23	6-C	03S40012G98	Screw, Countersink (M3 x 8)			80	4-E	54B62266F50	Label, Fuse		
24	1-H	28T51067F01	Plug, Short Phone			81	3-F	54B62266F51	Label, Fuse		
25	5-C	01V81600F19	Assy., Panel, Function LED.			82		09T45548F01	Holder, Fuse		
26	5-C	07B67320F01	Frame, LED			82		09T45548F01	Holder, Fuse		
27	2-C	09T51960F01	Holder, Fuse								
27	2-C	09T51960F01	Holder, Fuse								
28		29C41045P05	Lug, Wrap 54 mm								
31		07A81270F01	Bracket, Volt								
32	4-C	15A69033F01	Guide, Volume								
33	5-B	14S58462F59	Insulator, Cover								
34		75A67064F01	Felt								
36		03S44205G28	Screw, Bind (M4 x 14)								
38		03C40121T17	Screw, W/Double Washer (M3 x 8)								
41	3-E	47A82106F01	Shaft, P.C. Board								
42		03S40036U01	Screw, W/Washer (M4 x 8)								
43	3-E	47A81448F01	Shaft, Panel								
47	4-C	04S40070G23	Washer Flat (M3.3)								

Note: * : For Japanese model only (JM) Δ : For Canadian model only (UN)/North American model only (UL)

■ : For European model only (AM) Others: Common

Exploded View (Cabinet)

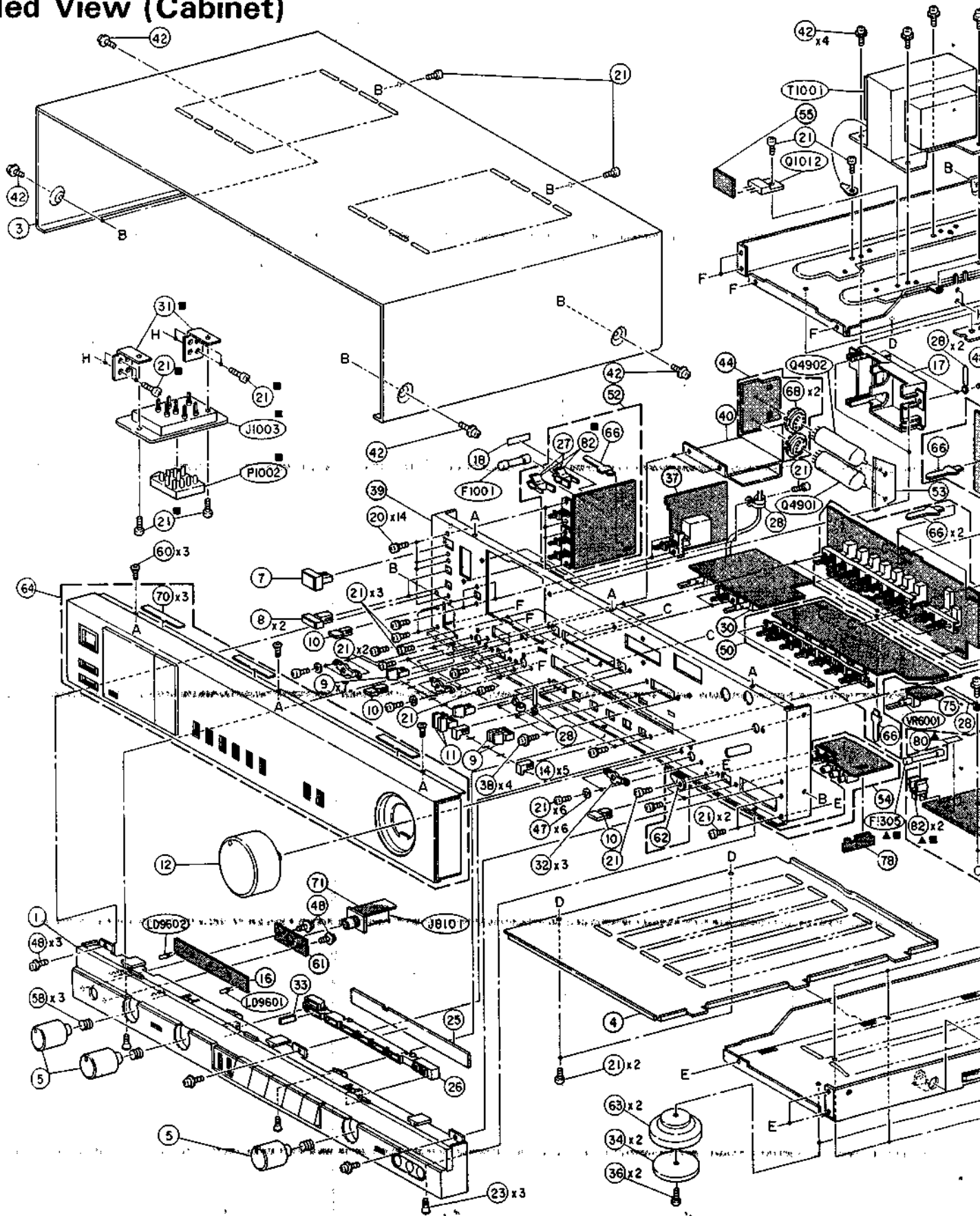

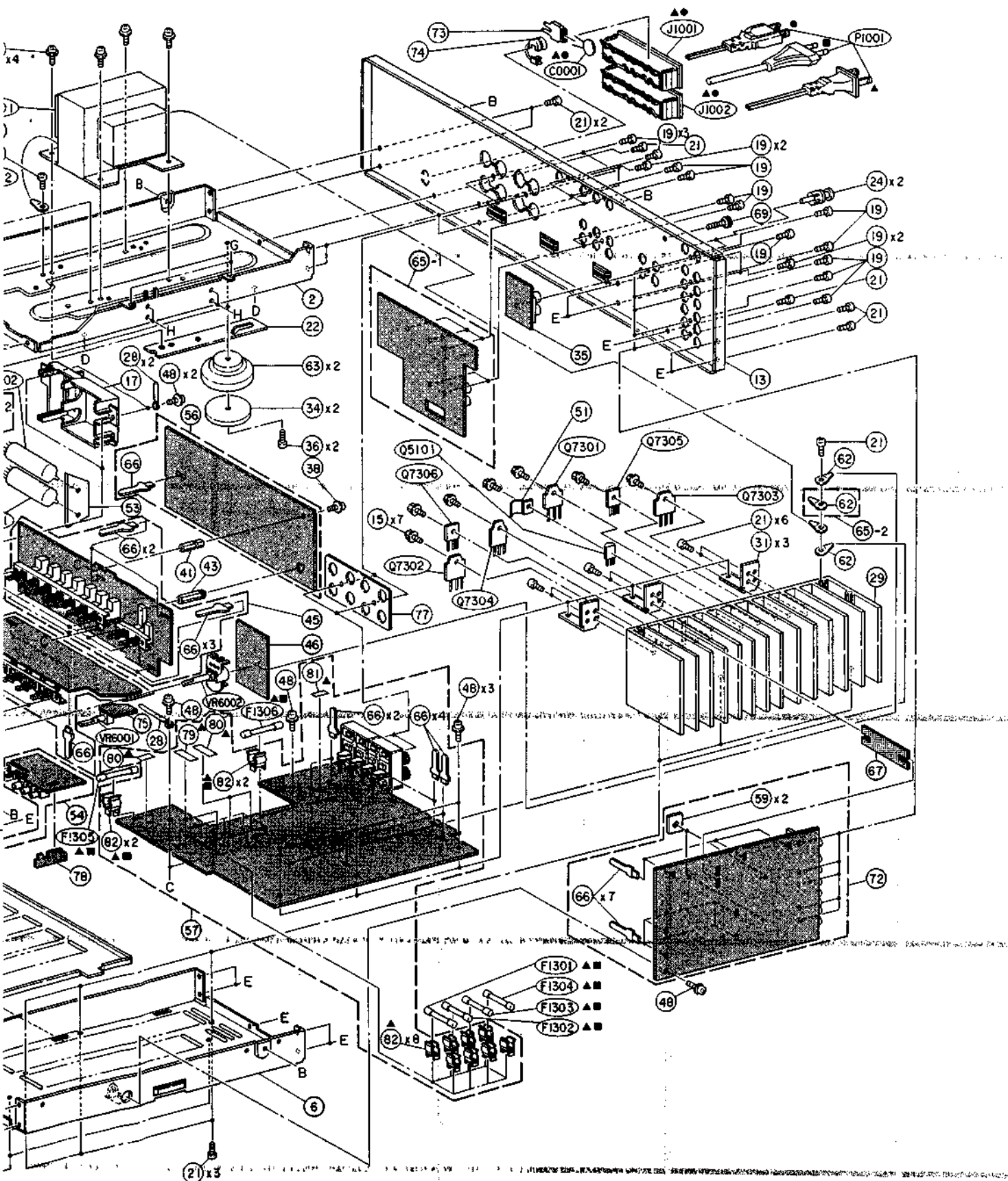

- : For Japanese model only (JM)
- ▲: For Canadian model only (UN)/
North American model only (UL)
- : For European model only (AM)

G

Semi-Conductor Lead Identifications

NJM78M12A: IC1119, 1120



1. Output
2. Common
3. Input

M5220P: IC2101
M5298P: IC4101

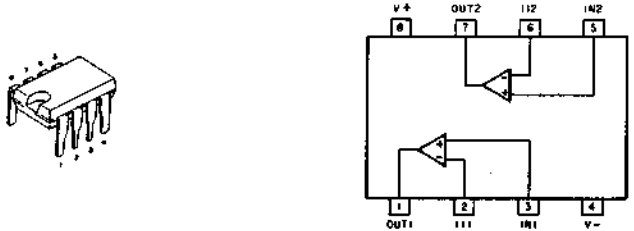

M51320P: IC3001

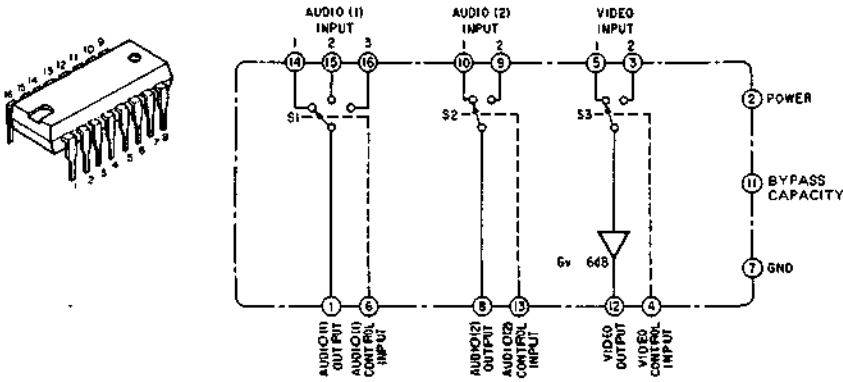

NJM4558D: 1C4102

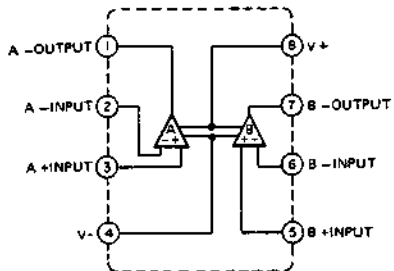
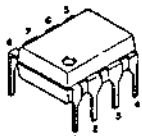

2SA970: Q5104, 7309, 7310
 2SC2240: Q5101, 7307, 7308, 7311, 7312
 2SA1015: Q1101, 1111, 1114, 1116, 5105
 2SC1815: Q1112, 1113, 1115, 1501, 1502,
 3001, 3002, 3003, 3004



TA7317P: 1C5101

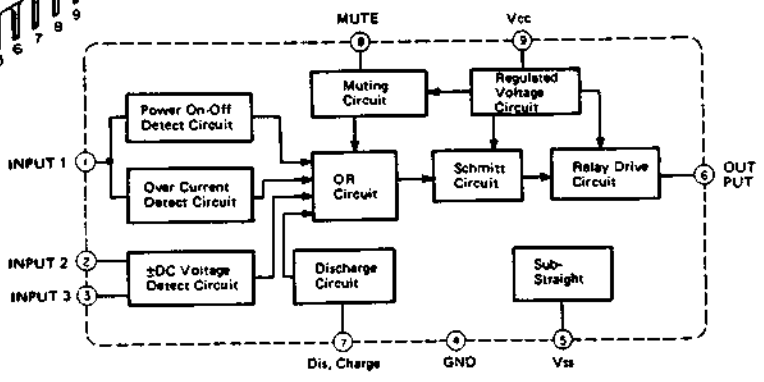
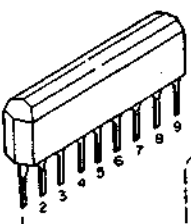

2SD1226: Q1012

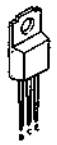

2SA1006: Q1102
 2SC2836: Q1101





2SC3423: Q1104, 1105, 1107, 1109, 7305, 7306
 2SA1360: Q1103, 1106, 1108, 1110, 7107, 7108
 2SA1361: Q7109, 7110



2SK30A: Q1117, 1118

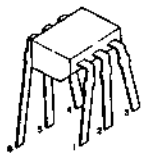
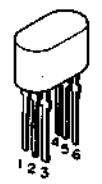
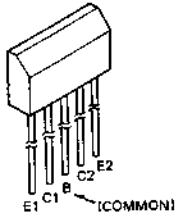

<p>2SK332:Q2101, 2102</p>  <p>1. Source 2. Gate 3. Drain 4. Drain 5. Gate 6. Source</p>	<p>2SJ75:Q7101, 7102</p>  <p>1. Drain 1 2. Gate 1 3. Source 1 4. Drain 2 5. Gate 2 6. Source 2</p>
<p>2SA995: Q7103, 7104 2SC2291:Q7105, 7106</p>  <p>E1 C1 B C2 E2 (COMMON)</p>	<p>2SJ115:Q7303, 7304 2SK405:Q7301, 7302</p>  <p>1. Gate 2. Drain 3. Source</p>

LUX CORPORATION, JAPAN
 1-1-8 Nishi Gotanda, Shinagawa-ku, Tokyo, 141 JAPAN
 Phone: 03-494-1101 Telex: 8927-61