

SERVICE MANUAL

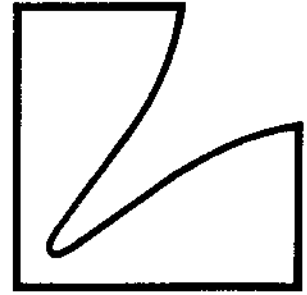

Compact Disc Player

D-113D

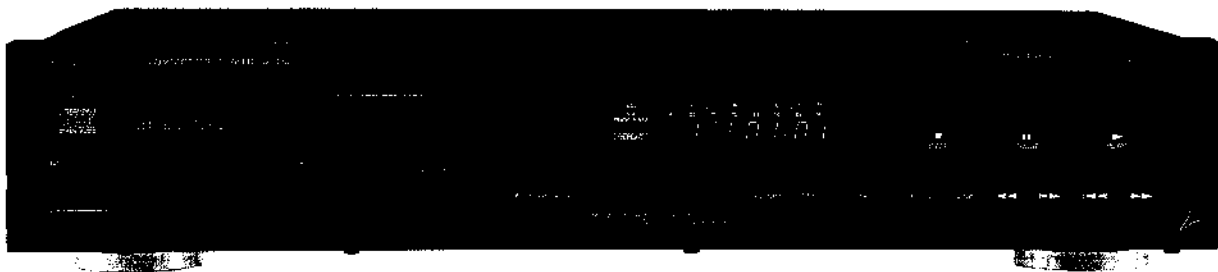

Destination	West German model	North American model	Canadian model	Japanese model
Serial Number	Before 80418600-B (AD)	Before 80620000-B (UZ)	Before □□□□□□□□-□ (UQ)	No Classification (JB)
	After 80820601-C (AE)	After 80821601-C (UV)	After □□□□□□□□-□ (UR)	

Contents

Specification	2
Controls & Switches Front Panel	3 to 4
Jacks & Terminals Rear Panel	5
Operation Guidelines	6 to 7
Disassembly Instructions	8 to 13
<Cabinet Section>	8
<Service Notes>	9 to 10
<CD Mechanism Section>	11 to 13
Adjustment Procedures	14 to 15
Adjustment Locations	16
Block Diagram	17
Packing Assembly Parts List	18
Packing Method View	18
Schematic Diagram	19 to 21
Parts Layout on P, C. Boards and Wiring Diagram	22 to 24
Electrical Parts List	25 to 27
Cabinet Assembly Parts List	28
Exploded View (Cabinet)	29 to 30
Exploded View (CD Mechanism)	31 to 32
CD Mechanism Assembly Parts List	33
Semi-conductor Lead Identification	34 to 37

Specifications

CD SECTION

System	Optical (Compact Disc System)
Quantizing Bit Number	16 Bit Linear System
Channels	2 Channel Stereo
Pick-up	Semiconductor Laser Pick-up
Digital Output Voltage	0.5V _{p-p} /75 ohm
Frequency Response	20~20kHz +1dB, -2dB
T.H.D (1kHz)	0.001%
S/N Ratio	85dB
Dynamic Range	83dB
Separation (1kHz)	75dB
Power Supply	AC120/220/240V, 50Hz (AD model only) AC120V, 60Hz (UZ, UQ model only) AC100V, 50/60Hz (JB model only)
Power Consumption	12W
Semiconductors	12 IC's, 17 Transistors 23 Diodes, 1 Zener Diodes
Dimensions (W × H × D)	438 × 85 × 314mm
Weight	4.4kg

COMPACT DISC

Track Pitch	1.6 μm
Modulation Frequency	44.1kHz
Transfer Rate	4.3218M Bit/Sec
Dimension	120 × 1.2mm (AD/UZ/UQ models only) 80 × 1.2mm (JB/AE/UV/UR models only)

NOTE: Due to continuing product improvement, specifications and design are subject to change without notice.

CONTROLS & SWITCHES — FRONT PANEL

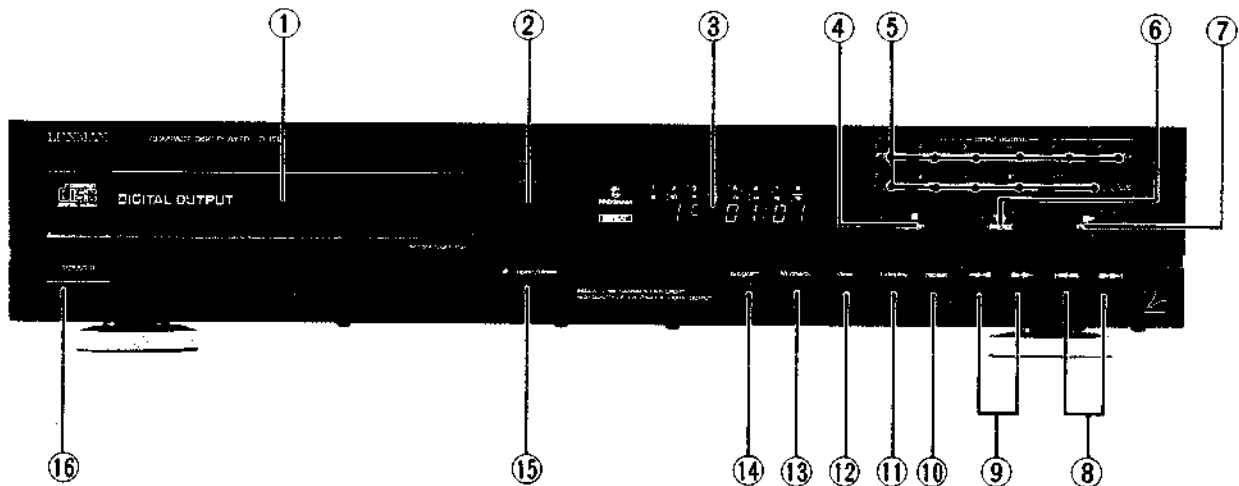

1. DISC TRAY

Place discs on this tray, label side up. A light touch on the tray, when open, will cause it to retrack back into the unit ready for play. Pressing "play" button or any "Direct Access" button will also close tray and go into immediate play operation.

NOTE: To place an 8 cm single CD on the disc tray, align the edge of the disc with the groove for the 8 cm single CD on the disc tray.

2. REMOTE SENSOR

When using the hand held remote control, it must be pointed toward this sensor to activate operational functions.

3. VACUUM FLUORESCENT DISPLAY

Track, index, time and programming functions are all simultaneously shown in this display. Refer to "operation guidelines" for details.

4. STOP Button

One press of this button will stop playback and return the pick-up to the beginning of the disc. A second push will clear (reset) all memory contents.

5. DIRECT ACCESS SELECT Buttons

Use for immediate play of any track from 1 to 99 or, in conjunction with the "program" button, select up to 16 tracks in any order for programmed operation.

6. PAUSE Button and Indicator

Press this button to temporarily cease playback or to cue up a track or segment for recording, etc. To resume playback, press the "pause" button again or press the play button.

NOTE: Fast Forward/Backward scan and skip operations (items #8 and 9) are still operable in the "pause" mode.

7. PLAY button and Indicator

Press play when loading a disc for immediate playback beginning at track 1 and for starting a programmed sequence. The indicator will light until play is cancelled.

NOTE: The indicator will blink during programming operations.

8. FORWARD/BACKWARD SKIP Buttons (▶▶, ◀◀)

These buttons allow one to "skip" forward or backward over any track in one track increments.

Pressing backward (◀◀) once will cause return to the beginning of the current track; a second immediate push will cause a skip back to the preceding track.

Pressing forward (▶▶) will cause the player to skip forward, one track at a time for each successive push. When the last selection is reached, the next push will return the pick-up to the first track.

CONTROLS & SWITCHES — FRONT PANEL

9. FAST FORWARD/BACKWARD SCAN Buttons

When pressed, these buttons provide fast forward or backward scan within a track (music) selection. To more than double these scan speeds, press the "pause" button (item #6) first.

10. REPEAT Button

In normal play mode, press this button to repeat all tracks on a disc.

In programmed play mode, pressing this button will repeat only those programmed.

Pressing the "repeat" button a second time, will cancel the repeat function.

11. t-DISPLAY Button

Each push of this button selects one of 2 disc timing displays as follows:

"Single Elapsed" — Time elapsed since beginning of current track. This occurs with "REMAIN" indicator OFF.

"Total Remain" — Play time remaining on entire disc. This occurs with "REMAIN" indicator ON.

NOTE 1. When in programmed play mode, the remaining time displayed will be that of the selections programmed, not the entire disc.

NOTE 2. If the Skip or Scan Buttons (items # 8 and 9) are used during programmed playback, the remaining time display will turn off.

12. CLEAR Button

This function allows track by track clearing, in sequence, of any programmed track, beginning with the last track programmed. With each push of this button, the next track to be cleared will appear in the Track No. Display and the red frame around the last programmed track No. will disappear.

NOTE: "Clear" operates only in the "Stop" mode.

13. M-CHECK Button

Use this button to check the order of the selections that have been programmed. With each successive push of this button, the track numbers that have been programmed will be shown to the left and the programme order to the right, in the track display area (the time portion of the display will turn off).

NOTE: "M-Check operates only in the "Stop" mode.

14. PROGRAM Button

Use this button in conjunction with the "Direct Access" Select buttons (item #5) to program up to 16 track selections in any random order. To clear program contents, press this button again or press the "stop" button twice.

15. OPEN/CLOSE Button

Press to open or close the disc tray (See also item #1).

16. POWER BUTTON

Press this button to turn power on and off to the unit. If disc is already loaded into the tray when power is turned on, the unit will automatically start playback, beginning with track #1.

JACKS & TERMINALS — REAR PANEL

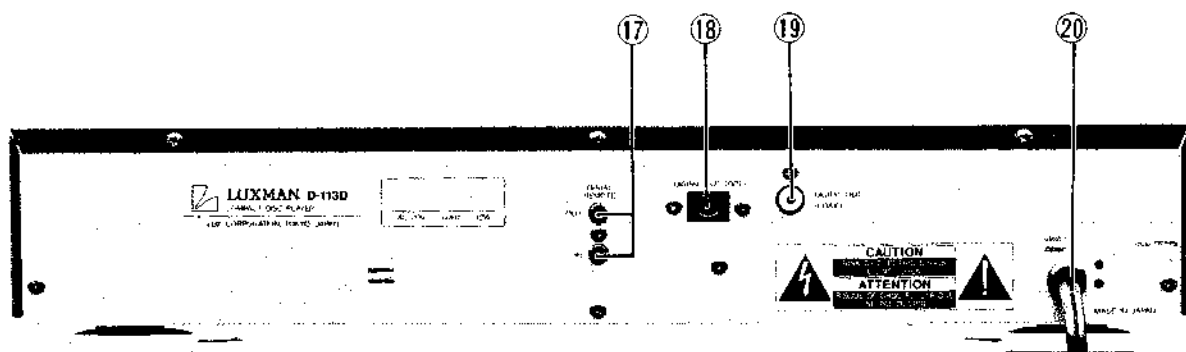

17. SERIAL REMOTE IN/OUT Jacks

Use these jacks for a simple and convenient connection of other Luxman components for Remote Control operation. Connect the Serial Remote In and Out jacks to the Serial Remote Out and In jacks, respectively, on other Luxman components (in daisy chain fashion), for a unified remote control system. See CONNECTION GUIDELINES, page 9.

NOTE: Turn the power off before connecting these jacks.

18. DIGITAL OUTPUT — (OPT.)

Use this digital output, with the supplied fiber optic connecting cable, for connection to a matching amplifier (such as the Luxman LV-113 or LV-117) that has an optical input jack.

NOTE: When not using this jack, leave the dummy plug (supplied) inserted.

19. DIGITAL OUTPUT TERMINAL

Use this digital output, with the supplied video patch cord, for connection to a matching amplifier having a patch cord (coax) phono jack type digital input (such as the Luxman LV-113 or LV-117).

20. AC POWER CORD

Insert the polarized AC plug of the D-113D into any 120 volt AC/60 Hz wall outlet, or, preferably, into the switched outlet of the amplifier or receiver used with it.

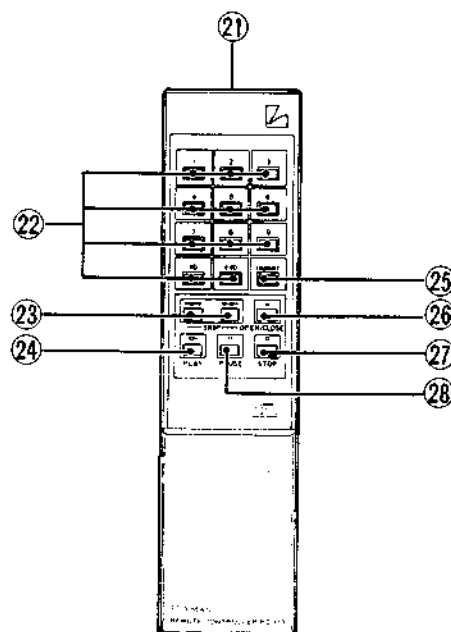

REMOTE CONTROLLER RD-113

NOTE: Operation is the same as for the buttons on the front panel.

21. TRANSMISSION WINDOW

22. DIRECT ACCESS Button

23. Forward/Backward Skip Buttons

24. PLAY Button

25. REPEAT Button

26. OPEN/CLOSE Button

27. STOP Button

28. PAUSE Button

OPERATION GUIDELINES

INITIAL SET-UP

Turn the power on to the component to be used. Turn the volume of the amplifier fully down, then adjust it to a suitable level just prior to playback.

Push the Open/Close Button on the D-113D and set a disc on the disc tray, label side up.

NOTE: To place an 8 cm single CD on the disc tray, align the edge of the disc with the groove for the 8 cm single CD on the disc tray.

NORMAL PLAY

1. After the disc is loaded, press the Play Button.
2. Playback will begin from the first track number, continuing on through the remaining tracks. As each track is completed, the number corresponding to it on the display will turn off.

NOTE: If the Repeat function is on, these numbers, on the display, will not turn off.

3. Playback automatically stops after the last track on the disc is played (unless in Repeat mode).

Examples:

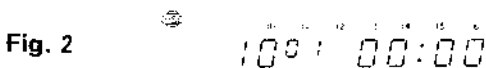
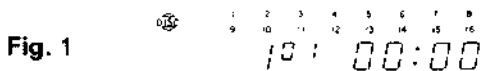

In Figure 1, all the track numbers are displayed and the track about to be played is displayed as 1 near the "DISC" () symbol.

In Figure 2, the tracks 1 through 9 have already been played back, and track 10 is currently in playback. The number 10 is displayed near the "DISC" symbol ().

Direct Access

1. Use the Direct Access Select Buttons (item #5) to specify a desired track.
2. All track numbers before this track will be cleared from the display, and playback will begin immediately.
3. Playback will stop automatically after the last track is played (unless in Repeat mode).

NOTE: If the Repeat function is on, the pickup will move to the desired track and begin playback, then continue through all the tracks remaining on the disc. It will then go back to the beginning of the disc and into continuous repeat.

Direct Access to the 10th Track

Press either Direct Access Select Button "10" or "+10" and the Play Button.

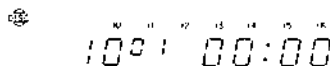

Direct Access From the 11th Track to the 19th Track.

Press the Direct Access Select Buttons "+10" and a number from 1 through 9.

Example: For direct access to the 17th track, press "+10" and "7".



Direct Access to the 20th Track

Press the Direct Access Select Buttons "+10" and "10" or "+10" twice and the PLAY button.

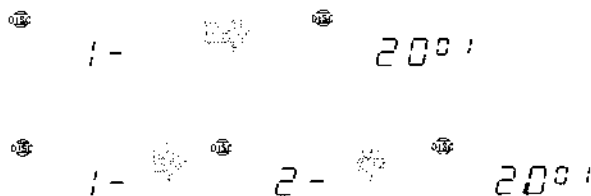

Direct Access to the 21st Track and Above.

Press the Direct Access Select Button "+10" twice, then press a number from 1 through 9.

Example: For direct access to track 26, press "+10", "+10" and "6".

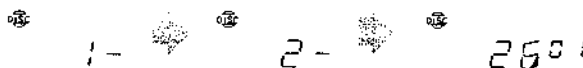

OPERATION GUIDELINES

NOTE:

Direct Access will be cancelled if a Direct Access Select Button other than "+10", the Play Button, or the Pause Button is not pressed within 4 seconds after pressing "+10".

The "+10" Button will not operate with discs containing 10 or fewer tracks.

PROGRAMMED PLAY OPERATIONS

Programming

1. Press the Program Button. "PROGRAM" will appear on the display. Choose a track number using the Direct Access Select Buttons. A red frame will light around that track number, and every other track number you program subsequently.

NOTE: For programming a track number higher than 10 on the disc, follow the instructions under "DIRECT ACCESS" for selecting the track number.

2. A maximum of 16 tracks can be programmed. If an attempt is made to program a 17th track, "FULL" will appear on the display for approximately 4 seconds, indicating that no more tracks can be programmed.
3. Programmed playback will begin immediately after the Play Button is pressed, beginning with the first track placed in memory.

NOTE: Programming can only be done in the Stop mode.

Example for Programming Tracks 11, 3, 5, 15 and 16

1. Press the Program Button.
2. Specify tracks 11, 3, 5, 15 and 16 using the Direct Access Select Buttons. (Press "+10" — "1", "3", "5", "+10" — "5", and "+10" — "6").

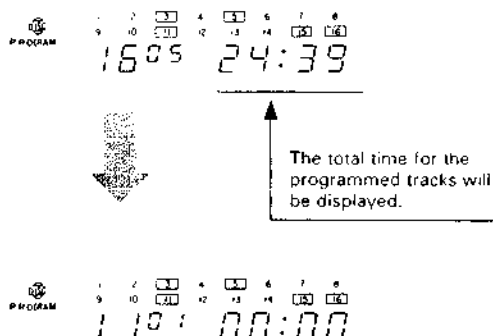

3. Press "PLAY" Button.
4. Playback stops once all programmed tracks have been played.
5. The red frame around each track number will disappear as that track is played. All remaining tracks will have a frame around them.

NOTE: If the Repeat Button has been pressed, "REPEAT" will be displayed and the frames around the track numbers will re-appear when the sequence repeats. Only those tracks programmed will be repeated.

Memory Check — Refer to Item #13

Clearing Programs

1. To clear program from memory, you must be in Stop mode. Simply press the Clear Button once for each track number you wish to clear.

NOTE: Clearing will begin with the last track programmed.

2. To clear the entire program, either press the program button a second time or press the Stop (reset) Button twice.

Repeat

When the Repeat Button is pressed during normal playback, all tracks on the disc will be repeated continuously.

If the Repeat Button is pressed during programmed playback, all programmed tracks will be repeated continuously.

If the Repeat Button is pressed during Signal Play, that track will be repeated continuously.

To cancel the Repeat mode, press the Repeat Button a second time and playback will continue to the end of the disc then stop, or press the Stop (reset) Button and playback will stop immediately.

TIMER PLAY

If a disc is already loaded into the Disc Tray when power is turned on by a timer, the unit will automatically start playback, beginning with track #1.

Disassembly Instructions

<Cabinet Section>

1. Removal of CD Mechanism

- (1) After removal of the top cover, open the disc tray as shown in Figure 1.
- (2) Remove the panel tray in the arrow direction as shown in Figure 1.
- (3) Remove four screws marked "O" as shown in Figure 2.
- (4) Disconnect all connectors from the CD Mechanism.

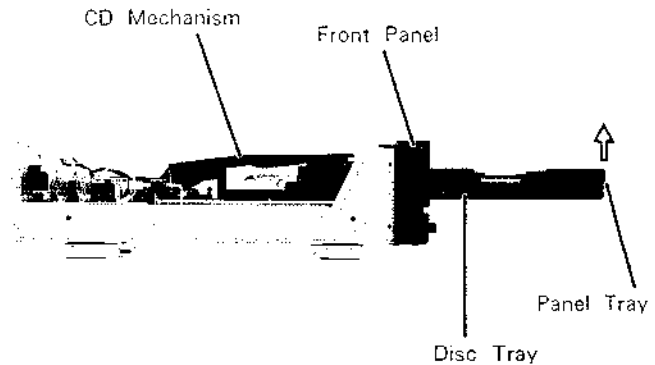

Figure 1

<1図>

1. CDメカニズムの外し方

- (1) 上蓋を外した後、ディスプレイをオープンにします。(1図参照)
- (2) トレイ・パネルを矢印の方向に外します。(1図参照)
- (3) 4本のネジ (O印) を外します。(2図参照)
- (4) CDメカニズムから出ている全てのコネクタを外します。

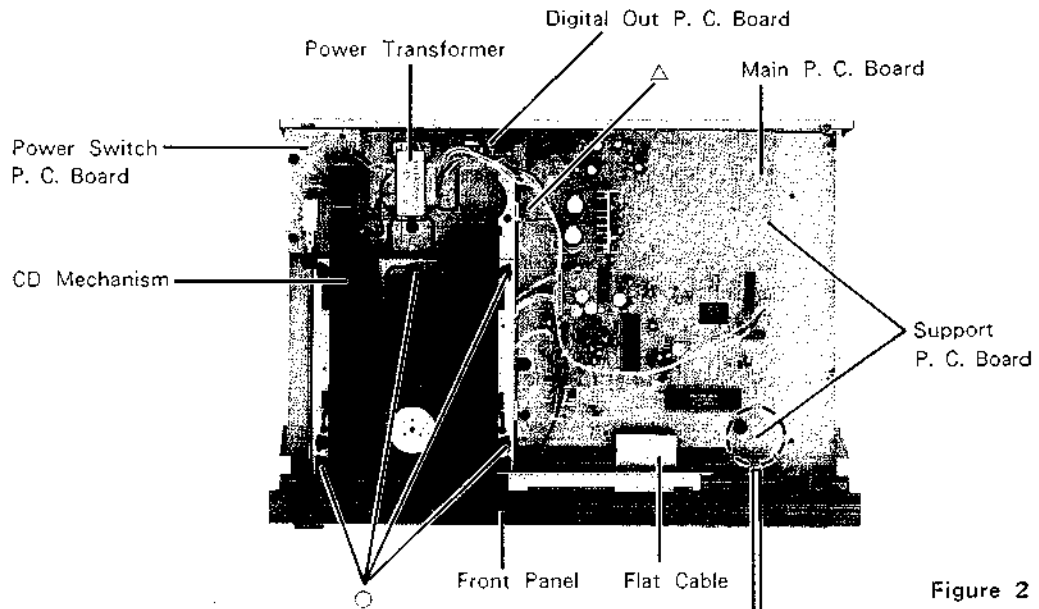

Figure 2

<2図>

2. Removal of FL/KEY Board P. C. Board

- (1) After removal of the tray panel, remove the front panel by disconnecting the flat cable from Main P. C. Board as shown in Figure 2.
- (2) Remove a screw marked "x" as shown in Figure 4.
- (3) Remove thirteen hooks as shown in Figure 4.

2. FL/KEY Board基板の外し方

- (1) トレイパネルを外した後、メイン基板から出ているフラットケーブルを外し、フロントパネルを外します。(2図参照)
- (2) 1本のネジ (x印) を外します。(4図参照)
- (3) 13ヶ所のフックを外します。(4図参照)

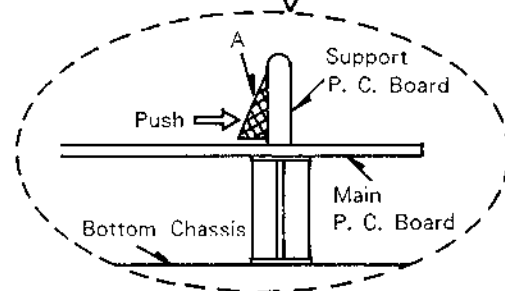

Figure 3

<3図>

3. Removal of Main P. C. Board

- (1) After removal of the top cover, remove three screws marked "△" as shown in Figures 2 and 5.
- (2) Remove two P. C. Board supports from Main P. C. Board as shown in Figure 2, by pushing the point "A" as shown in Figure 3.
- (3) Disconnect all wires from Main P. C. Board.

3. メイン基板の外し方

- (1) 上蓋を外した後、3本のネジ(△印)を外します。(2、5図参照)
- (2) 3図のようにA部を押してメイン基板から2本の基板サポートを外します。(3図参照)
- (3) メイン基板から出ている全てのワイヤーを外します。

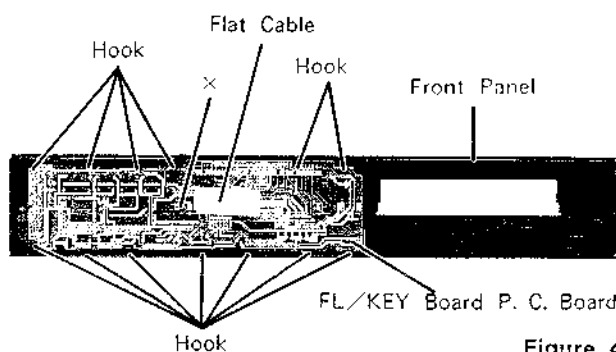

Figure 4
<4図>

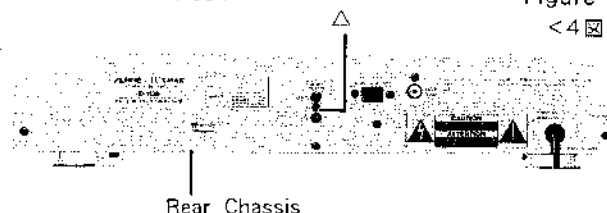

Figure 5
<5図>

<Service Notes>

1. Notes on Laser Diode Emission and Focus Search Operation Check

(1) Caution when checking Laser Diode emission.

The laser beam on this model is concentrated so as to be focused on the disc reflective surface by the objective lens in the optical pick-up block. Therefore, when checking the laser diode emission, observe from more than 30 cm away from the objective lens.

(2) Check of the Laser Diode And Focus Search Operation

With no disc loaded and the disc tray closed, when switching the power on, check that the operation as shown in the below Figure 6 is performed, by observing the objective lens.

- ①Optical pick-up moves in outer-circle and inner-circle directions.
- ②Laser beam emits spreadingly.
- ③The objective lens perform up-and-down three times.

1. レーザーダイオードおよびフォーカスサーチ動作の確認

(1) レーザーダイオードの発光確認時の注意

本機のレーザー光は、光学系ピックアップ内の対物レンズによってディスクの反射面上に焦点を結ぶように集光されています。したがって、レーザーダイオードの発光を確認する時は、対物レンズより30cm以上目を離して下さい。

(2) レーザーダイオードおよびフォーカスサーチ動作のチェック方法

ディスクを入れないでディスクトレイが閉じた状態から、POWERスイッチをONさせた時、対物レンズおよび光学系ピックアップを見て、下記の様な動作が行なわれるか確認する。(6図参照)

- ①光学系ピックアップが外周方向に動き、また内周方向に動く。
- ②レーザー光の拡散した、赤い色が見える。
- ③対物レンズの上下運動。(3回)

Remove the Clamp Arm
(See Disassembly Instruction of Clamp Arm)
クランプアームを取り除く
(クランプアームの分解方法の項参照)

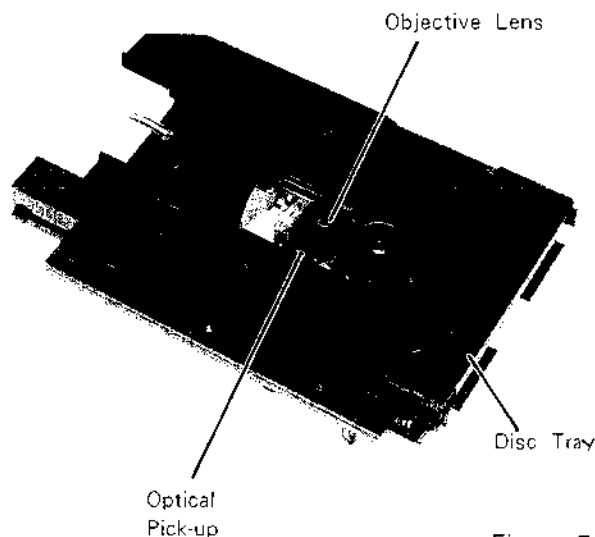

Figure 6
<6図>

2. Caution For Electrostatic Breakdown

[Notes on Handling The Base Unit (KSS-152A)]

The laser diode in the optical pick-up block may suffer electrostatic breakdown because of the potential difference generated by the charged electrostatic load, etc., on clothing and the human body.

The following notes are examples for reference purposes :

- ① Perform repair with ground ring on the hands and a conductive gum mat.
- ② Grasp the slide base when handling.
- ③ When removing the pick-up arm shortcircuit by soldering as shown in the Figure 7 below and then remove the connector.
- ④ When mounting the pick-up arm, after inserting the connector, remove the soldered shortcircuiting.

Notes : For making and removing the shortcircuit, be sure to use an iron with its metal part grounded or its insulation resistance is higher than 10M ohms (DC 500V), and the tip temperature is lower than 320°C. The soldering and desoldering should be made quickly.

2. 静電破壊についての注意

[KSS-152A (光学系ピックアップ) 取扱時の注意]

光学系ピックアップ内のレーザーダイオードは、衣服や人体に帯電した静電荷等で電位差を生じることにより、静電破壊することがあります。静電破壊に対する注意として下記のことに十分注意して取扱ってください。

- ① 取扱い時には、人体アースおよびアースマットを用いて接地してから作業を行ってください。
- ② 取扱いは、スライドベースを持って行って下さい。
- ③ 取りはずす時、7図のように半田ショートさせてから、コネクタを外して下さい。
- ④ 取付け時、コネクタを差し込んだ後、半田ショートの部分を開放して下さい。

注意) 半田ショートおよび開放時には、金属部分を接地させた半田ゴテか、もしくは通電5分後の絶縁抵抗が10MΩ以上 (DC500V) のもので、コテ先温度が320℃以下の半田ゴテかを使用してすみやかに行って下さい。

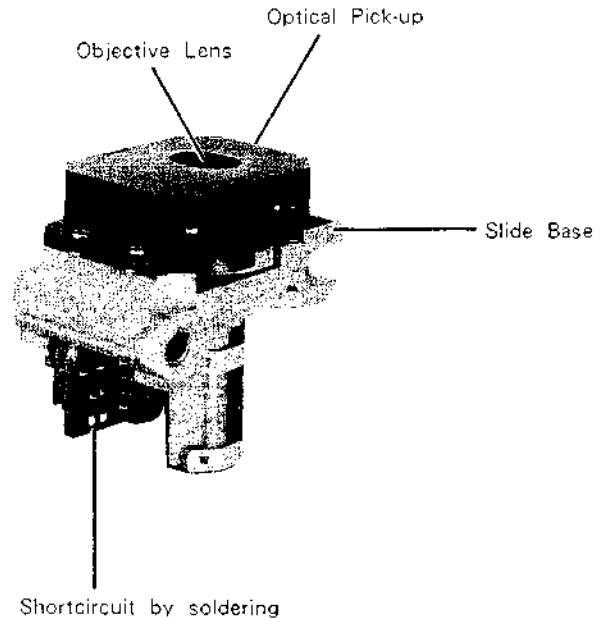

Figure 7

< 7 図 >

<CD Mechanism Section>

1. Removal of Disc Tray

- (1) Pull out the disc tray in the arrow direction by pressing slant position of the disc tray as shown in Figures 8 and 9.
- (2) After disengaging one claw (A), remove the switch arm as shown in Figure 10.
- (3) Spread two claws (B) toward outside at the both sides of the disc tray and draw out the disc tray as shown in Figure 9.

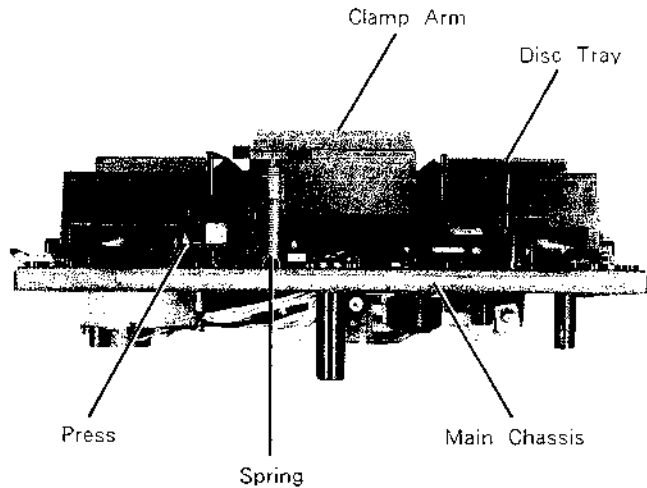

Figure 8

<8図>

1. ディスクトレイの外し方

- (1) ディスクトレイの斜線部分を押し、ディスクトレイを矢印方向に引き出す。(8、9図参照)
- (2) 爪 (A) を外し、スイッチアームを外します。(10図参照)
- (3) ディスクトレイ両サイドの爪 (B) を両外側に押し広げてディスクトレイを引き抜きます。(9図参照)

2. Removal of Clamp Arm

- (1) Remove one spring between the main chassis and the clamp arm as shown in Figure 8.
- (2) After pulling out the disc tray forward, remove the clamp arm by pressing one claw (C) as shown in Figure 9.

2. クランプアームの外し方

- (1) メインシャーシとクランプアームとを止めているバネを外します。(8図参照)
- (2) ディスクトレイを前面に引き出した後爪 (C) を押しながらクランプアームを外します。(9図参照)

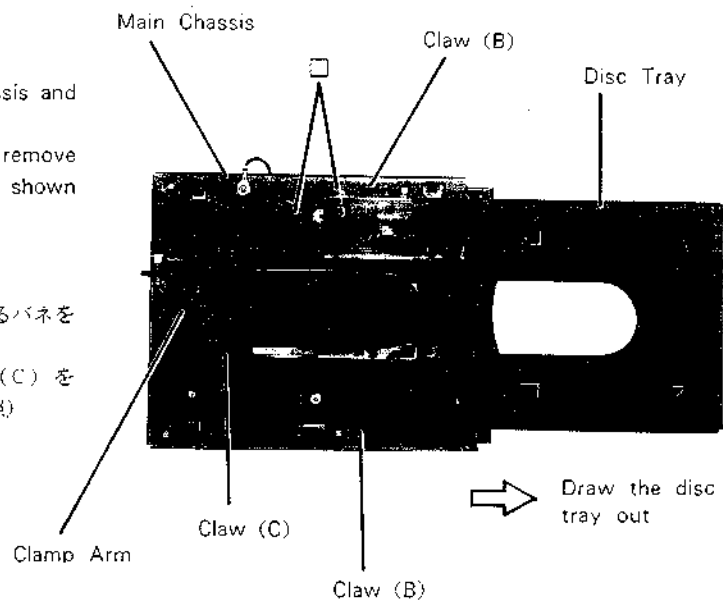

Figure 9

<9図>

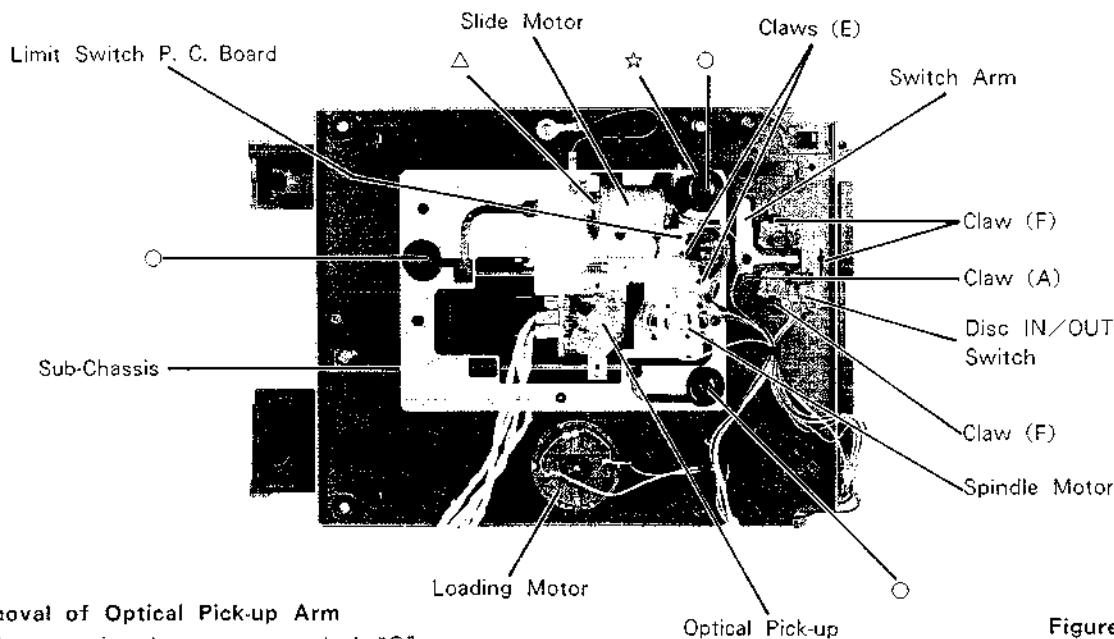

Figure 10
<10図>

3. Removal of Optical Pick-up Arm

(1) After removing three screws marked "○", remove the sub-chassis as shown in Figure 10.

Note: When three screws are removed, three springs (one is black) appear under the damper bush. When assembling the sub-chassis put the black spring into the place marked "☆".

(2) While pressing two claws (D) in toward pull out two shafts in the arrow direction as shown in Figure 12.

3. 光学系ピックアップの外し方

- (1) 3本のネジ (○印) を外し、サブシャーシを外します。
注意 3本のネジを外すとそれぞれのダンパーブッシュの下に3本のバネ (内1本が黒色) があります。サブシャーシ取り付け時には、黒色バネを"☆"色の部分に入れて取り付けて下さい。(10図参照)
- (2) 2ヶ所の爪 (D) を両方共に内側に押しながら、2本のシャフトを矢印の方向に引き抜きます。(12図参照)

4. Removal of Spindle Motor

(1) By grasping plastic part, lift the disc table straight up without applying pressure to metal part.

Note: For assembling the disc table, insert the disc table with pressure so that the height from the disc table top to the sub-chassis surface becomes 19.9 ± 0.1 mm in Figure 13.

(2) Remove two screws marked "×" as shown in Figure 12.

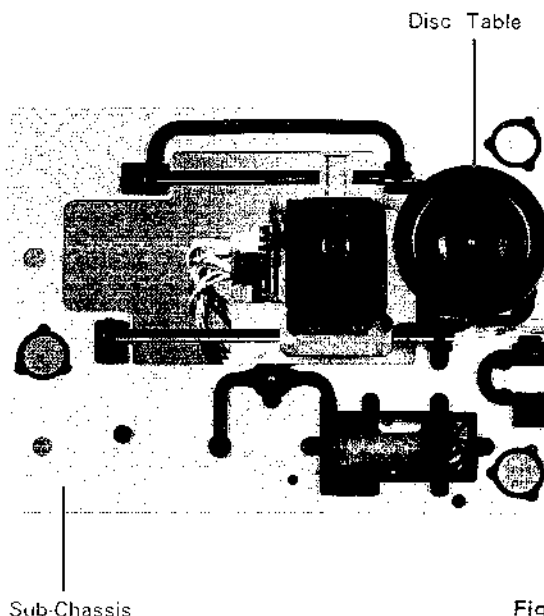

Figure 11
<11図>

4. スピンドルモーターの外し方

(1) ディスクテーブルを金属部分に負荷をかけないで樹脂の部分をつかみまっすぐ上に引き抜きます。

注意 ディスクテーブルの組立て時、サブシャーシ上面からディスクテーブルの上表面までの高さ 19.9 ± 0.1 mm の位置に圧入して下さい。(13図参照)

(2) 2本のネジ (×印) を外します。(12図参照)

5. Removal of Slide Motor

- (1) Remove one screw marked "△" and lift up the motor as shown in Figure 10.

5. スライドモーターの外し方

- (1) 1本のネジ (△印) を外し、上に持ち上げます。
(10図参照)

6. Removal of Loading Motor

- (1) Remove one belt and two screws marked "□" as shown in Figure 9.

6. ローディングモーターの外し方

- (1) ベルトを外し、2本のネジ (□印) を外します。
(9図参照)

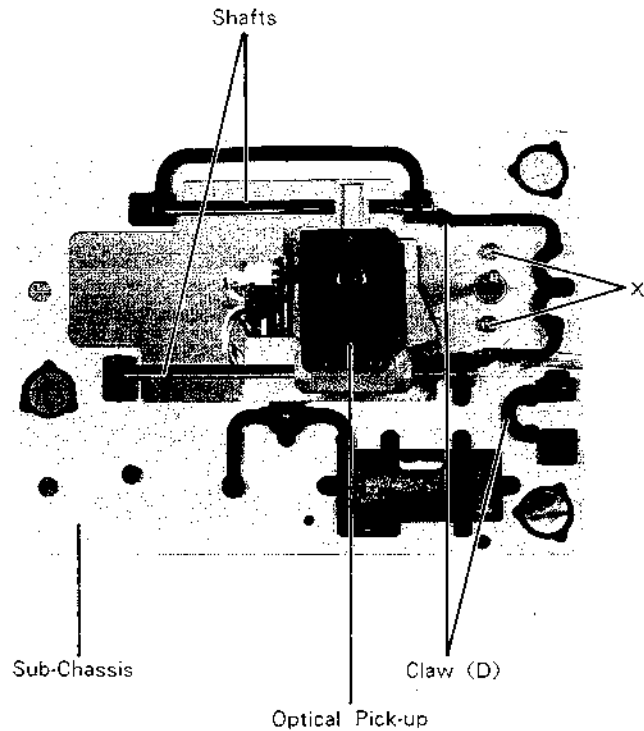

Figure 12
<12図>

7. Removal of Limit Switch P. C. Board

- (1) Remove two claws marked "E" as shown in Figure 10.

7. リミットスイッチ基板の外し方

- (1) 2ヶ所の爪 (E) を外します。(10図参照)

8. Removal of Disc IN/OUT Switch P. C. Board

- (1) Remove three claws marked "F" as shown in Figure 10.

8. ディスク IN/OUT スイッチ基板の外し方

- (1) 3ヶ所の爪 (F) を外します。(10図参照)

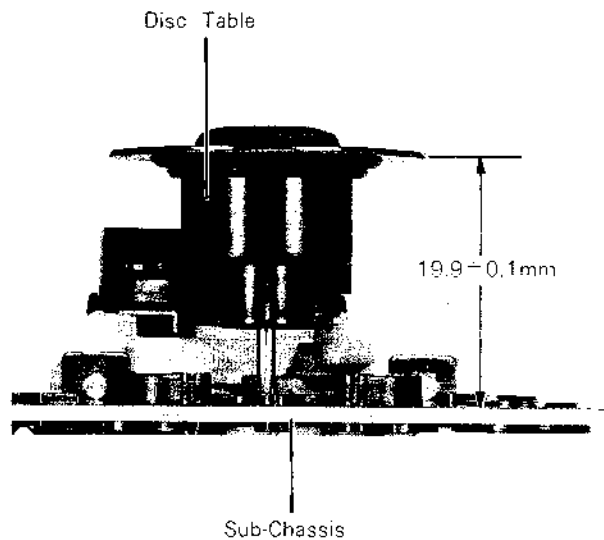

Figure 13
<13図>

Adjustment Procedures

1. Compact Disc Section

(1) Connections

(1) 接続図

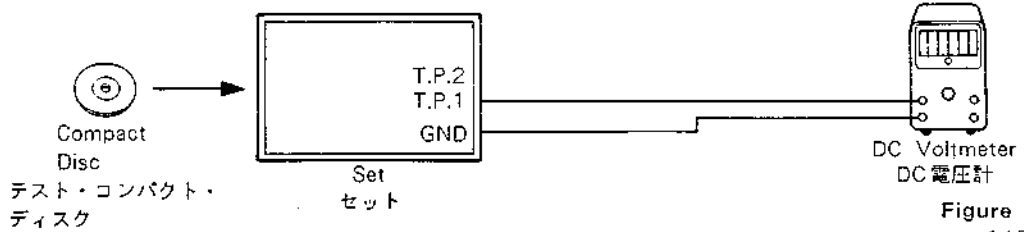

Figure 14

<14図>

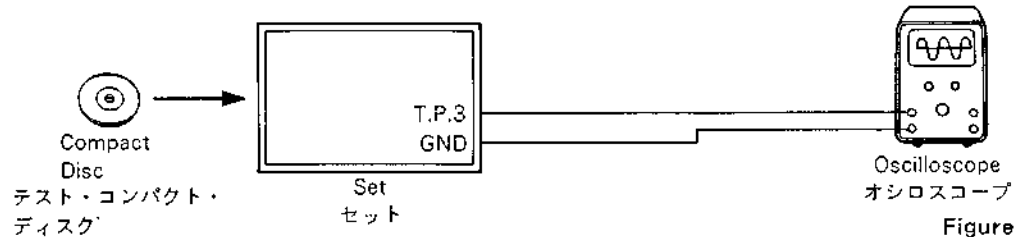

Figure 15

<15図>

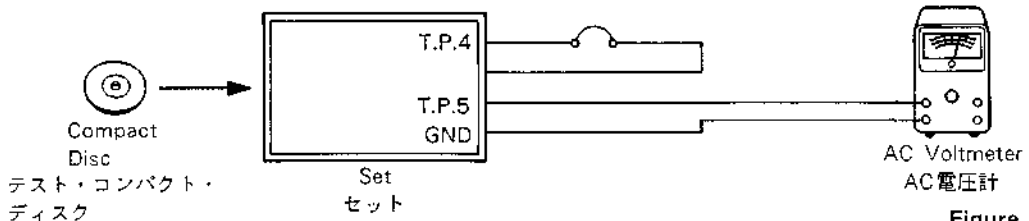

Figure 16

<16図>

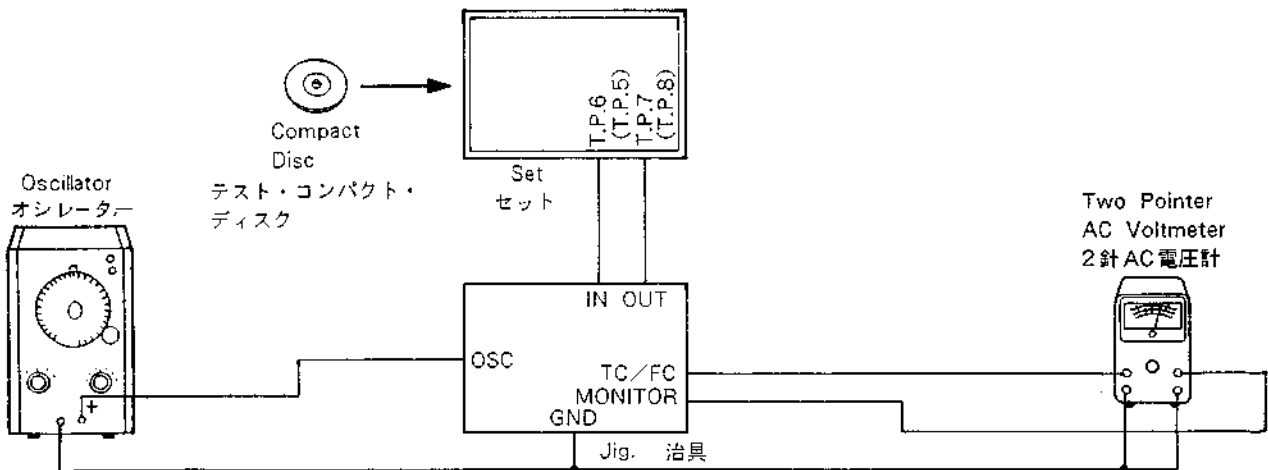

Figure 17

<17図>

(2) Control Settings

Power SwitchON
Play SwitchON
OthersOFF

(3) Adjustment Procedures

Step	Description	Connections	Oscillator	Test Point	Adjustment
1	VCO Adjustment	Figure 14	-	T.P.1	Take measurement of the voltage at the T.P.1. Then adjust VR1303 so that the output voltage at the T.P.2 becomes $1/2$ of the voltage at the T.P.1.
2	Focus Bias Adjustment	Figure 15	-	T.P.3	Adjust VR1202 so that the waveform of output at the T.P.3 becomes maximum as shown on Fig. 18.
3	Tracking Error Balance Adjustment	Figure 16	-	T.P.4 T.P.5	After shortcircuiting T.P.4 and turning VR1301 fully counterclockwise, adjust VR1201 so that the voltage is $0V \pm 50mV$. After the adjustment set VR1301 to its center position.
4	Tracking Gain Adjustment	Figure 17	1kHz 200mV	T.P.6 T.P.7	Adjust VR1302 so that both arms of the voltmeter come at the same position.
5	Focus Gain Adjustment	Figure 17	1kHz 200mV	T.P.5 T.P.8	Adjust VR1301 so that both arms of the voltmeter come at the same position.

(2) スイッチ類のセット位置

電源スイッチON
 プレイスイッチON
 その他のスイッチOFF

(3) 調整方法

順序	調整項目	接続図	オシレーター	テストポイント	調整方法
1	VCO調整	14図	-	T.P.1	T.P.1の電圧を測定します。次にT.P.2の出力電圧がT.P.1の電圧の $1/2$ になる様にVR1303で調整します。
2	フォーカスバイアス調整	15図	-	T.P.3	T.P.3の出力が波形が図18の様に最大になる様にVR1202で調整します。
3	トラッキングエラーバランス調整	16図	-	T.P.4 T.P.5	T.P.4をショートしてVR1301を反時計方向にしどりきり、T.P.5の出力電圧が $0V \pm 50mV$ になる様にVR1201で調整します。 調整後、VR1301を中央付近にもどす事。
4	トラッキングゲイン調整	17図	1kHz 200mV	T.P.6 T.P.7	2針AC電圧計の針が重なる様にVR1302で調整します。
5	フォーカスゲイン調整	17図	1kHz 200mV	T.P.5 T.P.8	2針AC電圧計の針が重なる様にVR1301で調整します。

Note : Test CD

For the VCO adjustment, use the 4th track on the EIAJ CD.
 For the other adjustments than VCO, use the 1st track on the EIAJ CD.

※テストCD

EIAJ CD (4曲目) → VCO調整
 EIAJ CD (1曲目) → VCO以外の調整

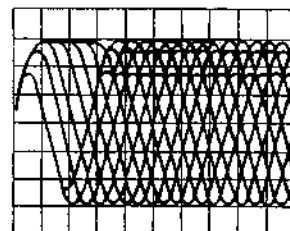
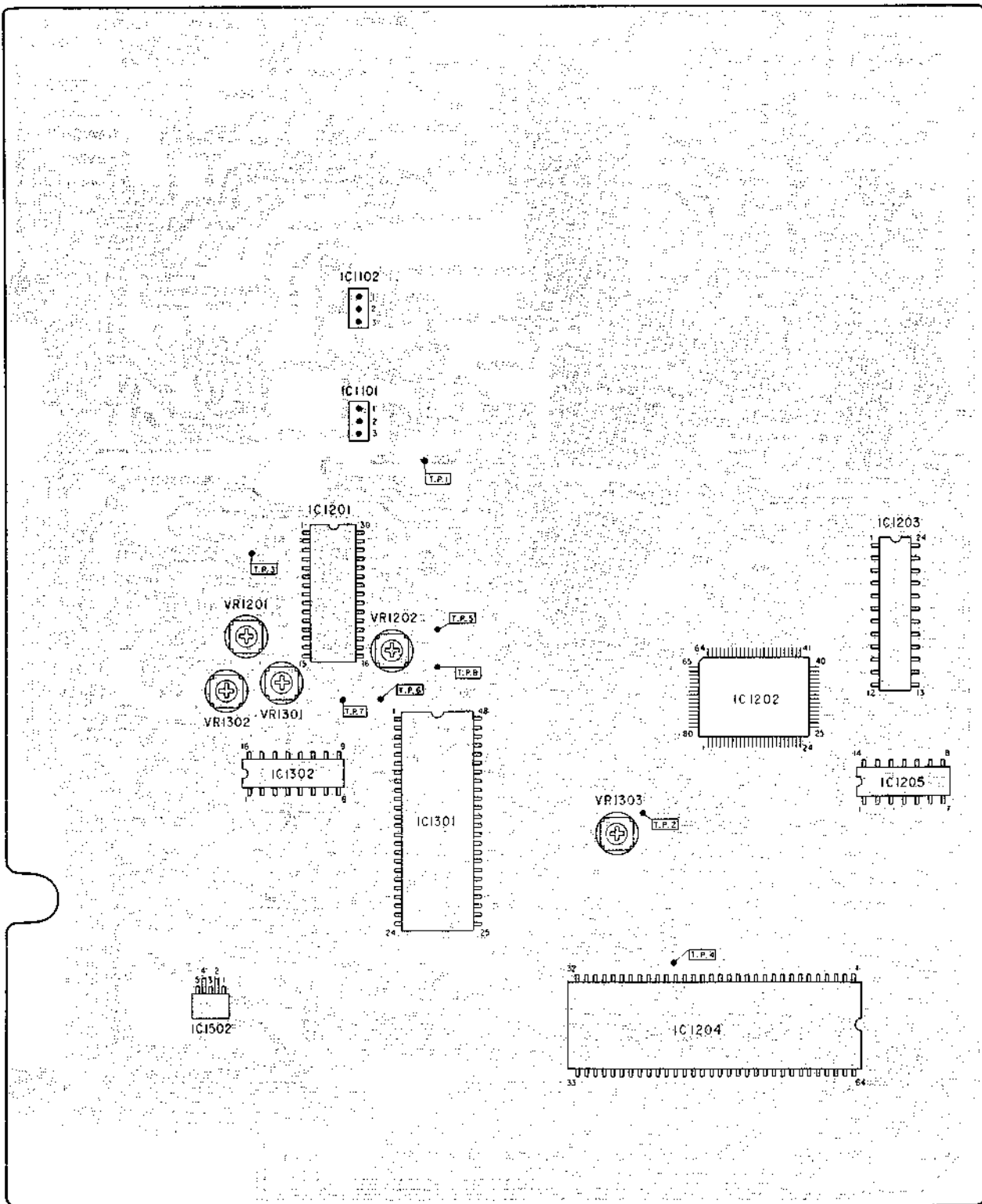

Figure 18
 < 18図 >

Adjustment Locations



Main P. C. Board

Block Diagram

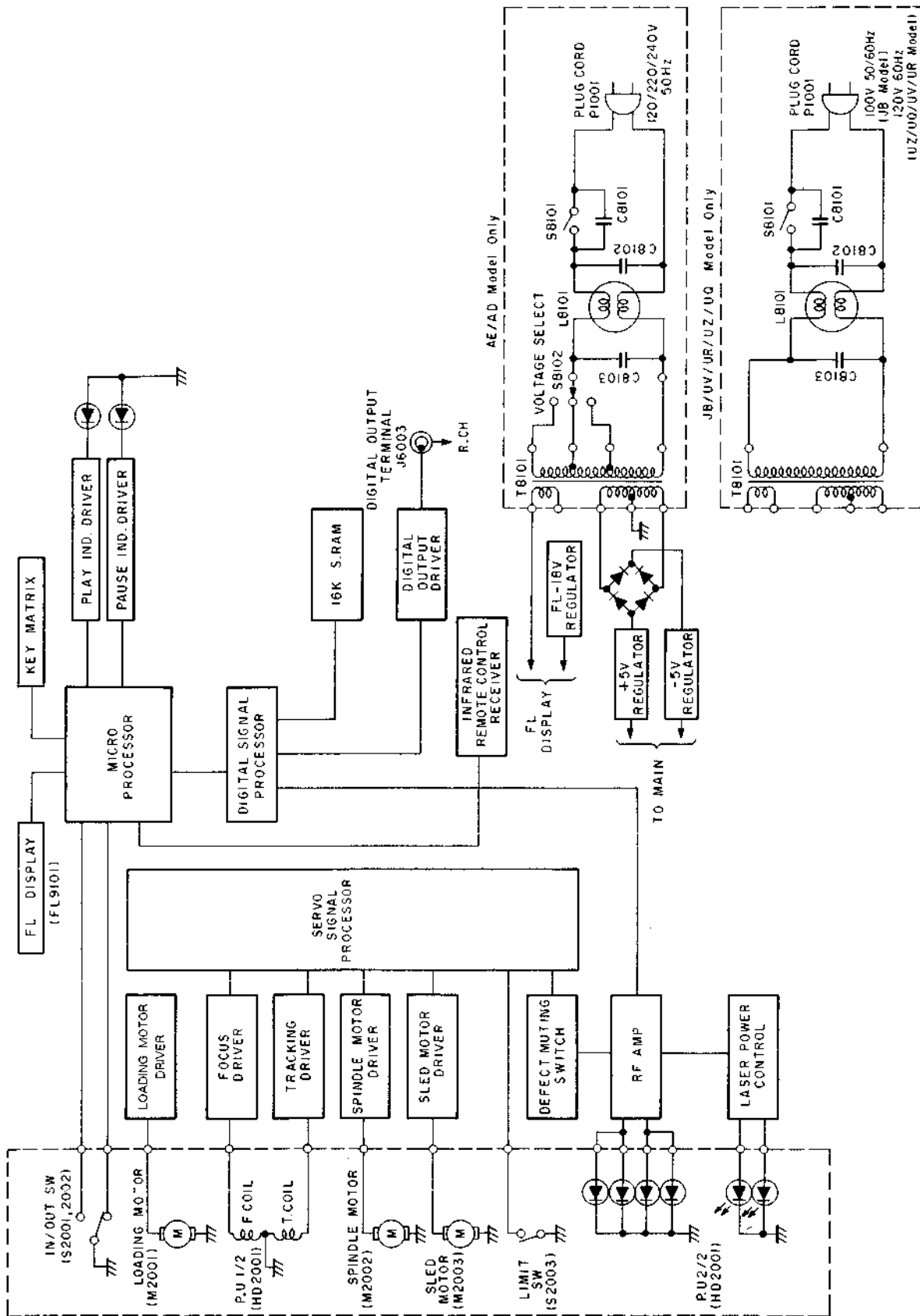

Packing Assembly Parts List

Symbol No.	Part No.	Description	Symbol No.	Part No.	Description	
■	101-1	68P83710F51 Owner's Manual	101-4	60T81756F01	Battery, UM-4UC	
▲	101-1	68P83710F53 Owner's Manual	101-5	01T84773F01	Fiber, TOCP172-150CB	
●	101-1	68P83710F53 Owner's Manual	101-6	28T71168F01	Cord, Video	
○	101-1	68P83710F53 Owner's Manual	▲	102	56S10005W04	Carton, Packing
△	101-1	68P83710F53 Owner's Manual	●	102	56S10005W04	Carton, Packing
×	101-1	68P83710F52 Owner's Manual	■	102	56S83833F51	Carton, Packing
※	101-1	68P83710F52 Owner's Manual	○	102	56S10005W04	Carton, Packing
	101-2	01T82091F01 Assy., Mini Plug Cord	△	102	56S10005W04	Carton, Packing
●	101-3	01T90545F01 Unit, Remocon (RD113)	※	102	56S10005W04	Carton, Packing
▲	101-3	01T90545F01 Unit, Remocon (RD113)	×	102	56S10005W04	Carton, Packing
■	101-3	01T90545F02 Unit, Remocon (RD113JA)	103	56D90648F01	Tray, Packing	
○	101-3	01T90545F01 Unit, Remocon (RD113)	104	56D90649F01	Tray, Packing	
△	101-3	01T90545F01 Unit, Remocon (RD113)	105	56B40230G23	Sack, Polyethylene	
×	101-3	01T90545F01 Unit, Remocon (RD113)	106	56B40230G08	Sack, Polyethylene	
※	101-3	01T90545F01 Unit, Remocon (RD113)				

Notes: ● : For West Germany model only (AD), ■ : For Japanese model only (JB), ▲ : For Canadian model only (UQ),
○ : For West Germany model only (AE), △ : For Canadian model only (UR), × : For North American model only (UZ),
※ : For North American model only (UV), Others: Common.

Packing Method View

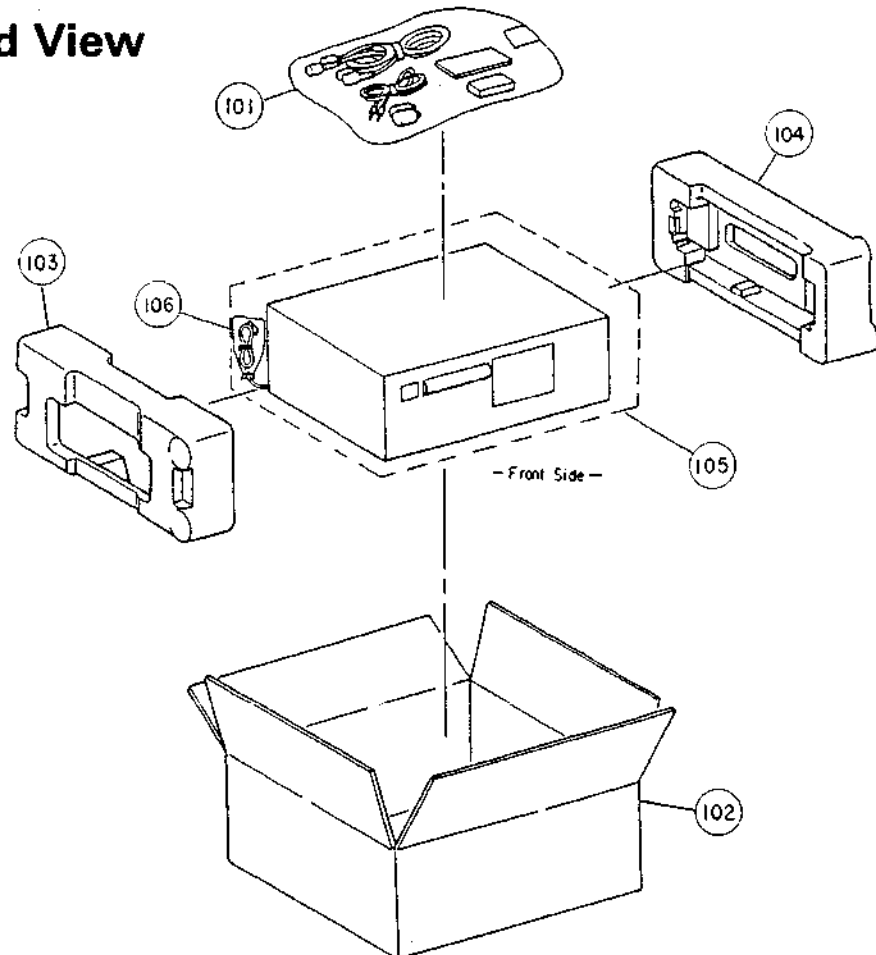

Schematic Diagram

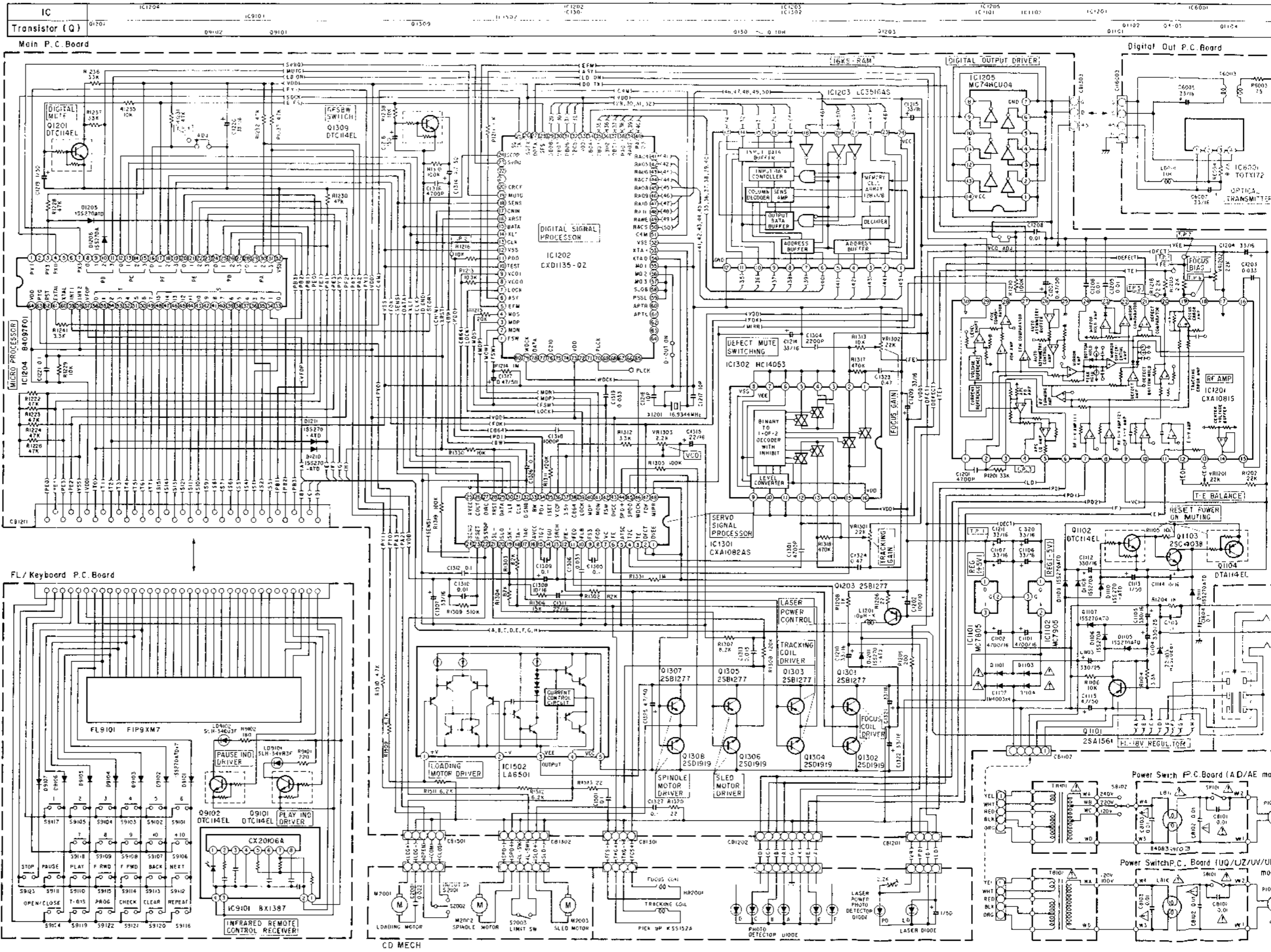

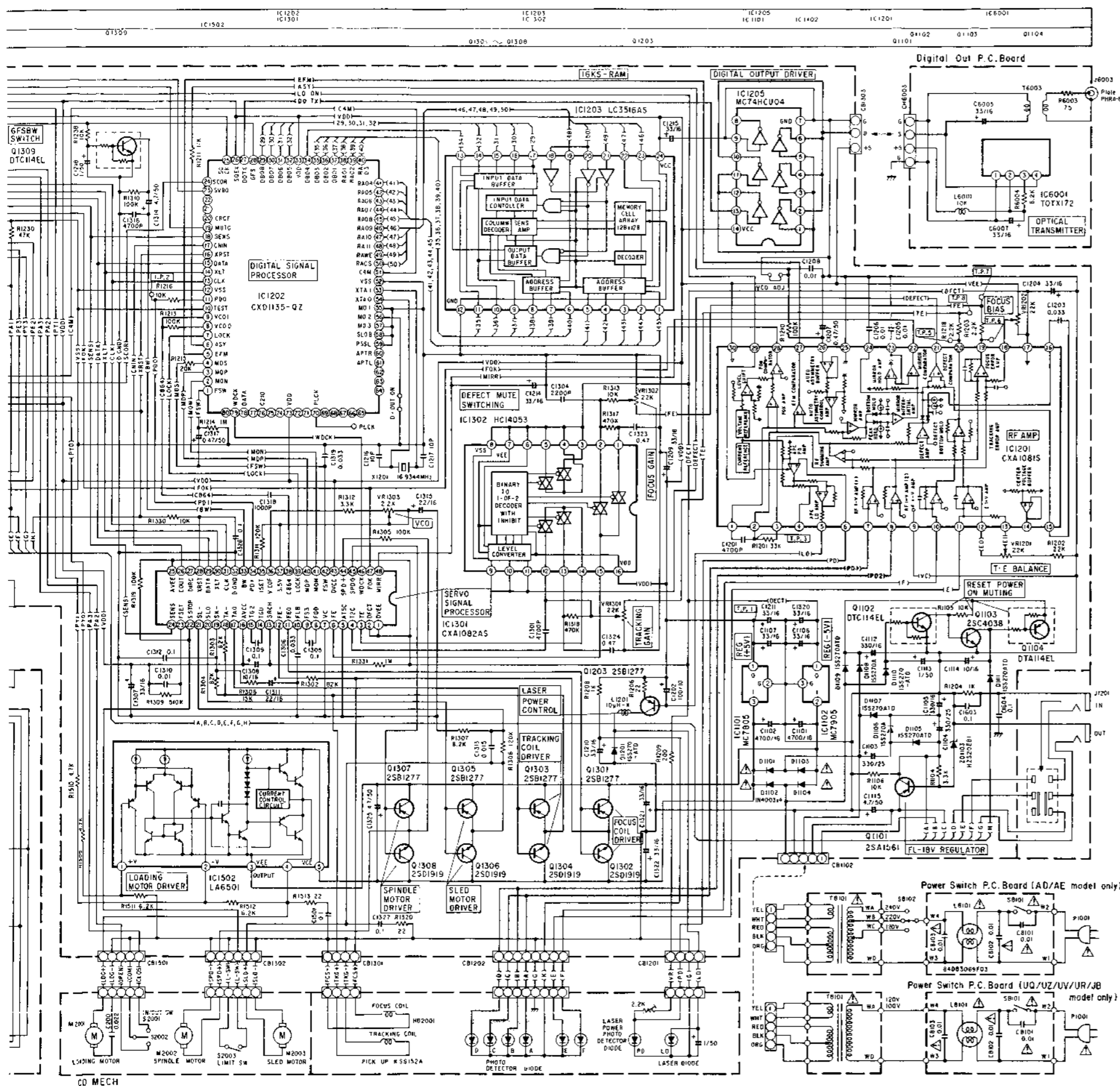

	F	T	B
Q1101	-17.14	106	18.45V
Q1102	05	26	7.2V
Q1103	00	10.35	06
Q1104	10.55	-55	10.25
Q1201	00	2.85	2.85
Q1203	3.85	1.75	3.4V
Q1301	06	-11.1	0.94
Q1302	00	10.25	0.94
Q1303	00	-11.1	-0.35
Q1304	00	10.25	-0.41
Q1305	00	-11.1	1.04
Q1306	00	10.25	1.04
Q1307	00	-11.1	1.04
Q1308	00	10.25	1.04
Q1309	00	00	2.77V
Q1310	00	8.81V	00
Q1312	00	3.05V	00

	F	T	B
1	0V	15	5V
2	0V	18	4V
3	5V	15	24
4	5V	15	24
5	5V	20	0V
6	0V	21	0V
7	0V	22	0V
8	0V	23	0V
9	5V	25	0V
10	0V	26	0V
11	0V	27	0V
12	5V	28	0V
13	5V	29	0V
14	4V	30	0V
15	5V	31	0V
16	5V	32	0V

	F	T	B
1	5V	11	-5V
2	0V	11	-5V
3	10.25	11	0V

	F	T	B
1	0V	16	-2.5V
2	1V	17	-5V
3	0V	18	0.1V
4	5V	19	0V
5	3.4V	20	0V
6	5V	21	-5V
7	0V	22	0V
8	0V	23	-1.9V
9	0V	24	-1V
10	0V	25	0V
11	0V	26	3.5V
12	0.8V	27	2.5V
13	-0.5V	28	5V
14	0V	29	0V
15	-2V	30	5V

	F	T	B
1	2.4V	0	5V
2	2.35V	0	5V
3	2.16V	10	2.55V
4	2.53V	11	2.48V
5	2.49V	12	2.49V
6	2.24V	13	2.52V
7	0V	14	5V

	F	T	B
1	5V	25	-5V
2	5V	26	0.1V
3	0V	27	5V
4	0V	28	5V
5	0V	29	4.5V
6	0V	30	5V
7	0V	31	5V
8	0V	32	5V
9	0V	33	2.5V
10	0V	34	2.5V
11	0V	35	2.77V
12	0V	36	2.4V
13	0V	37	3.5V
14	0V	38	2V
15	0V	39	5V

	F	T	B
1	0V	41	2.5V
2	0V	42	2.5V
3	0V	43	2.5V
4	0V	44	2.5V
5	0V	45	2.5V
6	2.5V	46	2.5V
7	5V	47	2.5V
8	2.5V	48	0V
9	0V	49	0V
10	0V	50	2.5V
11	0V	51	0V
12	0V	52	0V
13	0V	53	5V
14	0V	54	2V
15	0V	55	0V
16	0.14V	56	0V
17	0.15V	57	0V
18	0.10V	58	0V
19	0.15V	59	0V
20	2.10V	60	2.5V

	F	T	B
1	0V	41	5V
2	0V	42	5V
3	0V	43	5V
4	0V	44	5V
5	0V	45	5V
6	0V	46	5V
7	0V	47	5V
8	0V	48	5V
9	0V	49	5V
10	0V	50	5V
11	0V	51	5V
12	0V	52	5V
13	0V	53	5V
14	0V	54	5V
15	0V	55	5V

	F	T	B
1	5V	51	5V
2	0V	52	5V
3	-11V	53	5V
4	0V	54	5V
5	10.2V	55	5V

	F	T	B
1	2.5V	13	0V
2	2.5V	14	0V
3	2.5V	15	0V
4	2.5V	16	0V
5	2.5V	17	0V
6	2.5V	18	2.7V
7	2.5V	19	3V
8	2.5V	20	2.7V
9	0V	21	4.4V
10	0.1V	22	2.4V
11	0V	23	2.5V
12	0V	24	5V

(Measuring Conditions)
 • Power Supply Voltage: 120/220/240V 50Hz(AD/AE)
 • 120V 60Hz(UQ/UZ/LV/LK)
 • 100V 50/60Hz(JR)
 • Measuring Meter: Digital Multi Voltmeter
 • Measuring Point Reference: Between Ground
 • Measuring Condition: No Signal Input
 • CB In Play Condition

CAUTION:
 The Δ mark, the symbol numbers in the schematic diagram designate components which have special characteristics important for safety and should be replaced only with types identical to those in the original circuit or specified in the parts list.

NOTES:
 1. All resistance values are in ohms. K = 1,000
 2. All capacitance values are in microfarads. P = $\frac{1}{1,000,000}$

D-113 D

Parts Layout on P.C. Boards and Wiring Diagram

FL/Keyboard P.C. Board

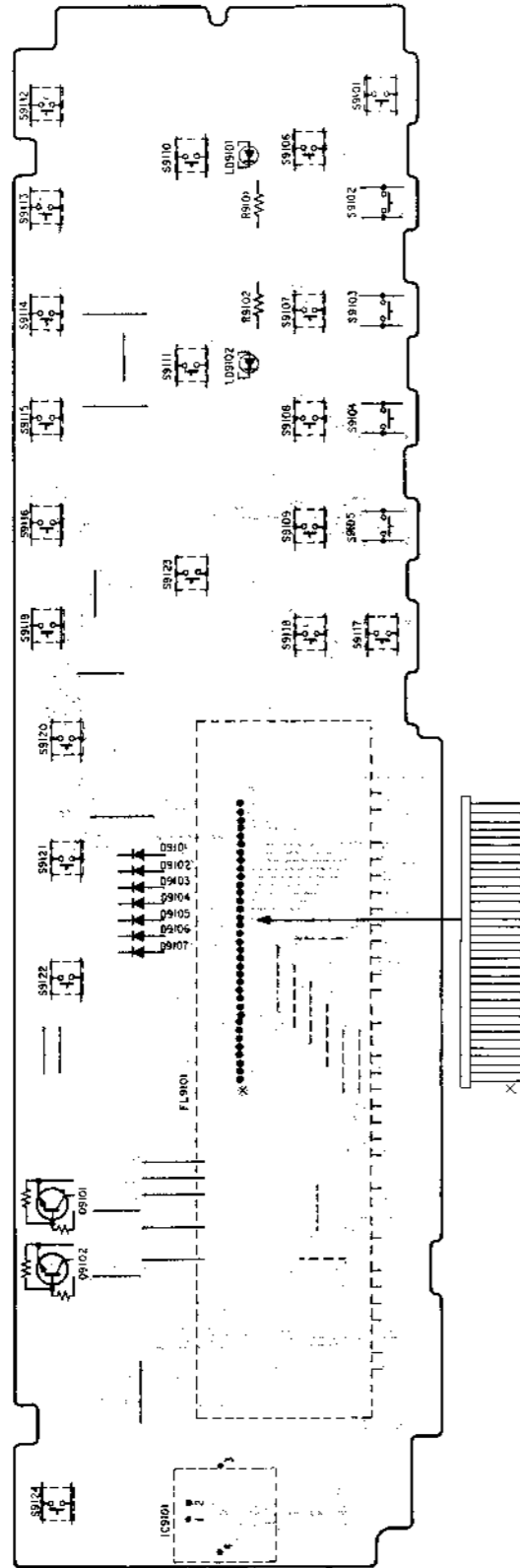

Main P.C. Board

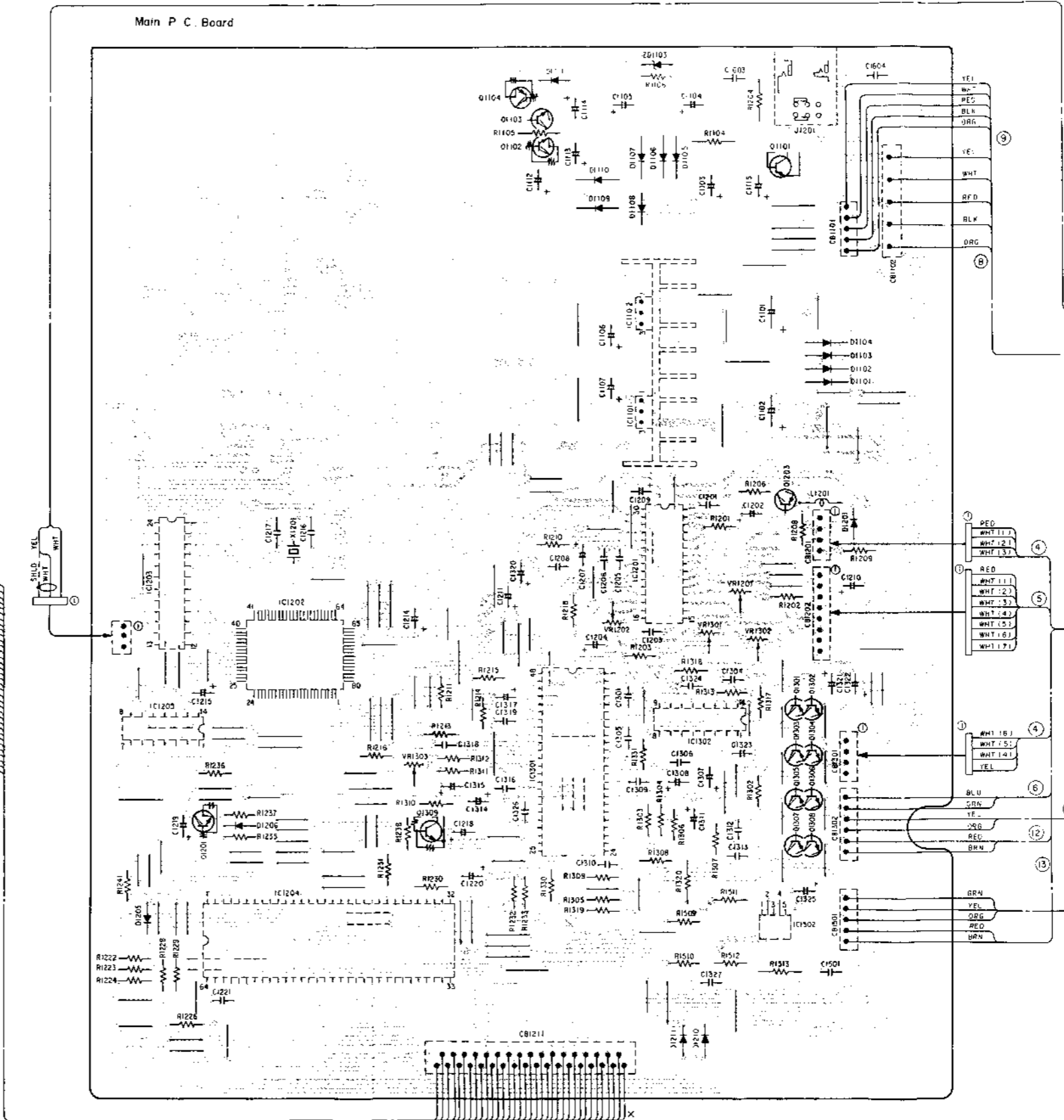

Digital Out P.C. Board

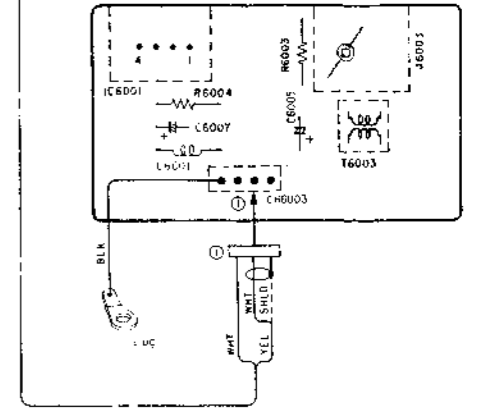

IN/Out Switch P.C. Board

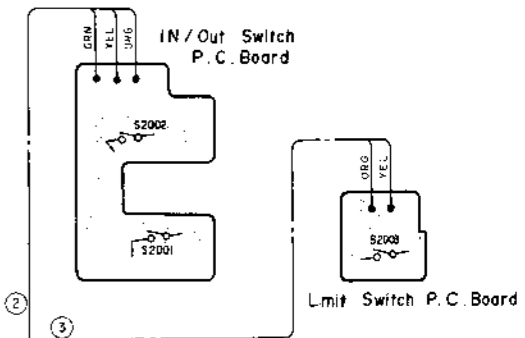

Limit Switch P.C. Board

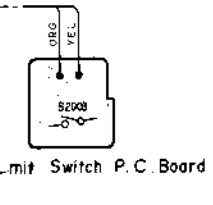

Power Switch P.C. Board

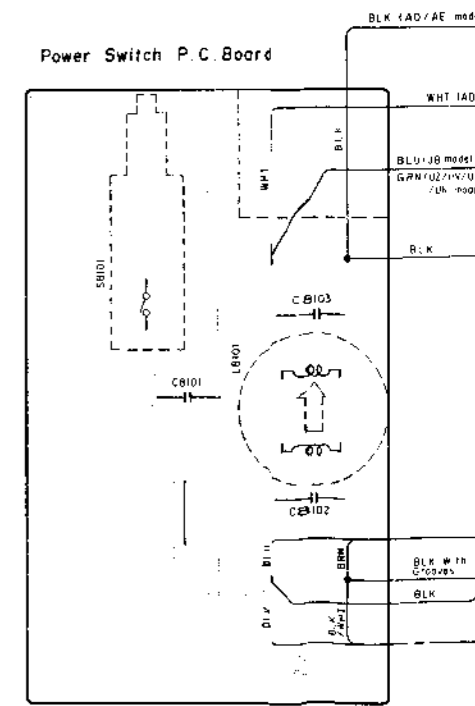

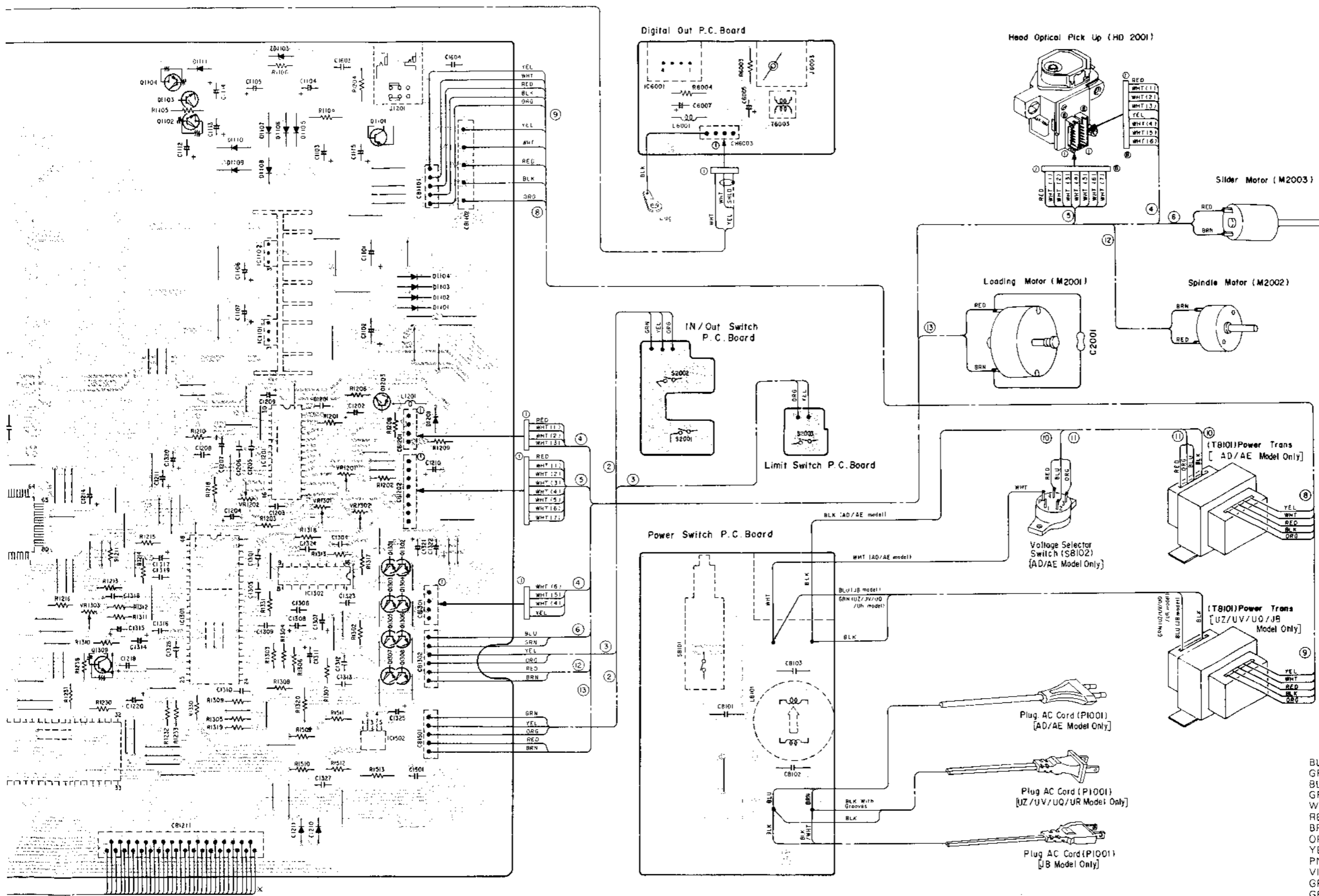

BLU	Blue
GRN	Green
BLK	Black
GRY	Gray
WHT	White
RED	Red
BRN	Brown
ORG	Orange
YEL	Yellow
PNK	Pink
VIO	Violet
GRN/WHT	Green/White
GRY/WHT	Gray/White
GRY/YEL	Gray/Yellow
GRN/YEL	Green/Yellow
SHLD	Shield

Electrical Parts List

Resistor : Carbon resistors under 1/4 watts are not mentioned in the parts list, please confirm them by schematic diagram.
 uF = microfarads. pF = picofarads

Abbreviations					Symbol No.	Part No.	Description		
RES. = Resistor CAP. = Capacitor C.F. = Carbon Film ELY. = Electrolytic M.F. = Metal Film CER. = Ceramic M.O. = Metal Oxide Film MYL. = Mylar M.P. = Metal Plate TAN. = Tantalum TR. = Transistor POLY. = Polystyrol TRANS. = Transformer PP. = Polypropylene CP. = Chip PLT. = Polyethylene					Symbol No.	Part No.	Description		
Main P. C. Board									
IC's									
IC1101	51T94884F01	MC7805			D1101	48S40477U01	IN4003		
IC1102	51T94885F01	MC7905			D1102	48S40477U01	IN4003		
IC1201	51T84721F01	CXA1081S			D1103	48S40477U01	IN4003		
IC1202	51T84719F01	CXD1135QZ			D1104	48S40477U01	IN4003		
or	51T84720F01	CXD1125QZ			D1105	48T84758F01	1SS270ATD		
					or	48T58583F01	1SS176		
IC1203	51T84723F01	LC3516AS			D1106	48T84758F01	1SS270ATD		
or	51T80623F02	CXK5816SP			or	48T58583F01	1SS176		
IC1204	51T84097F01	84097F01			D1107	48T84758F01	1SS270ATD		
IC1205	51T94890F01	MC74HCU04			or	48T58583F01	1SS176		
IC1301	51T84722F01	CXA1082AS			D1108	48T84758F01	1SS270ATD		
					or	48T58583F01	1SS176		
IC1302	51T94886F01	MC14053			D1109	48T84758F01	1SS270ATD		
IC1502	51T90889F01	LA6501			or	48T58583F01	1SS176		
Transistors					D1110	48T84758F01	1SS270ATD		
Q1101	48T82757F01	2SA1561			or	48T58583F01	1SS176		
Q1102	48T82763F02	DTC114EL			D1111	48T84758F01	1SS270ATD		
Q1103	48T82758F01	2SC4038			or	48T58583F01	1SS176		
Q1104	48T82762F02	DTA114EL			D1201	48T84758F01	1SS270ATD		
Q1201	48T82763F02	DTC114EL			or	48T58583F01	1SS176		
Q1203	48T82759F01	2SB1277			D1205	48T84758F01	1SS270ATD		
Q1301	48T82759F01	2SB1277			or	48T58583F01	1SS176		
Q1302	48T83275F01	2SD1919			D1206	48T84758F01	1SS270ATD		
Q1303	48T82759F01	2SB1277			or	48T58583F01	1SS176		
Q1304	48T83275F01	2SD1919			D1210	48T84758F01	1SS270ATD		
Q1305	48T82759F01	2SB1277			or	48T58583F01	1SS176		
Q1306	48T83275F01	2SD1919			D1211	48T84758F01	1SS270ATD		
Q1307	48T82759F01	2SB1277			or	48T58583F01	1SS176		
Q1308	48T83275F01	2SD1919			ZD1103	48T68697F60	Zener. HZS20EB1		
Q1309	48T82763F02	DTC114EL			Coil/Crystal/Jack				
					L1201	24T50508F22	Coil, Inductor 10 u H		
					X1201	48T84727F01	AT-51 16.9344M		
					J1201	09T84124F01	Jack, Headphone Mini W		
					Capacitors				
					C1101	23T00135L34	ELY., 4700 u F/16V		
					C1102	23T00135L34	ELY., 4700 u F/16V		
					C1103	23S40657F65	ELY., 330 u F/25V		
					C1104	23S40657F65	ELY., 330 u F/25V		
					C1105	23S40657F61	ELY., 330 u F/16V		

Symbol No.	Part No.	Description			Symbol No.	Part No.	Description		
C1106	23T00138L19	ELY., 33 μ F/16V			C1501	08T57705F79	MYL., 0.1 μ F		
C1107	23T00138L19	ELY., 33 μ F/16V			C1603	08T57298F01	CER., 0.1 μ F		
C1112	23S40657F61	ELY., 330 μ F/16V			C1604	08T57298F01	CER., 0.1 μ F		
C1113	23T00138L45	ELY., 1 μ F/50V			Resistors (All resistors are variable unless otherwise noted.)				
C1114	23T00138L17	ELY., 10 μ F/16V			VR1201	18C41732G08	22k ohm (T.E.BALANCE)		
C1115	23T00138L48	ELY., 4.7 μ F/50V			VR1202	18C41732G08	22k ohm (FOCUS BIAS)		
C1201	08T57705F63	MYL., 4700pF			VR1301	18C41732G08	22k ohm (T.GAIN)		
C1202	23T00138L12	ELY., 100 μ F/10V			VR1302	18C41732G08	22k ohm (F.GAIN)		
C1203	08T57705F73	MYL., 0.033 μ F			VR1303	18C41732G18	2.2k ohm (VCO)		
C1204	23T00138L19	ELY., 33 μ F/16V			Digital Out P. C. Board				
C1205	08T57705F67	MYL., 0.01 μ F			IC/Coil/Transformer/Capacitors				
C1206	08T57705F67	MYL., 0.01 μ F			IC6001	51T84772F01	TOTX172		
C1207	23T00138L44	ELY., 0.47 μ F/50V			L6001	24T50508F22	Coil, Inductor 10 μ H		
C1208	08T57705F67	MYL., 0.01 μ F			T6003	25T94882F01	TRANS., Puls		
C1209	23T00138L19	ELY., 33 μ F/16V			C6005	23T00138L19	CAP., ELY., 33 μ F/16V		
C1210	23T00138L19	ELY., 33 μ F/16V			C6007	23T00138L19	CAP., ELY., 33 μ F/16V		
C1211	23T00138L19	ELY., 33 μ F/16V			Power Switch P. C. Board				
C1214	23T00138L19	ELY., 33 μ F/16V			Coil/Switch/Capacitors				
C1215	23T00138L19	ELY., 33 μ F/16V			LB101	24T82315F01	Coil, FLT. 160mH		
C1216	08T55260F13	CER., 10pF			S8101	40T84122F01	Switch, SDDLE 9 (Power)		
C1217	08T55260F13	CER., 10pF			C8101	08T57437F09	CER., 0.01 μ F		
C1218	23T00138L45	ELY., 1 μ F/50V			C8102	08T57437F09	CER., 0.01 μ F		
C1219	23T00138L45	ELY., 1 μ F/50V			C8103	08T57437F09	CER., 0.01 μ F		
C1220	23T00138L19	ELY., 33 μ F/16V			FL/Key Board P. C. Board				
C1221	08T57298F01	CER., 0.1 μ F			IC/Transistors				
C1301	08T57705F63	MYL., 4700pF			IC9101	51T84120F01	BX1387		
C1304	08T57705F59	MYL., 2200pF			Q9101	48T82763F02	TR., DTC114EL		
C1305	08T57705F79	MYL., 0.1 μ F			Q9102	48T82763F02	TR., DTC114EL		
C1306	08T57705F73	MYL., 0.033 μ F							
C1307	23T00138L19	ELY., 33 μ F/16V							
C1308	23T00138L17	ELY., 10 μ F/16V							
C1309	08T57705F79	MYL., 0.1 μ F							
C1310	08T57705F67	MYL., 0.01 μ F							
C1311	23T00138L18	ELY., 22 μ F/16V							
C1312	08T57705F79	MYL., 0.1 μ F							
C1313	08T57705F69	MYL., 0.015 μ F							
C1314	23T00138L48	ELY., 4.7 μ F/50V							
C1315	23T00138L18	ELY., 22 μ F/16V							
C1316	08T57705F63	MYL., 4700pF							
C1317	23T00138L44	ELY., 0.47 μ F/50V							
C1318	08T57705F55	MYL., 1000pF							
C1319	08T57705F73	MYL., 0.033 μ F							
C1320	23T00138L19	ELY., 33 μ F/16V							
C1321	23T00138L19	ELY., 33 μ F/16V							
C1322	23T00138L19	ELY., 33 μ F/16V							
C1323	08T57851F21	T.F., 0.47 μ F							
C1324	08T57851F21	T.F., 0.47 μ F							
C1325	23T00138L48	ELY., 4.7 μ F/50V							
C1326	08T57298F01	CER., 0.1 μ F							
C1327	08T57705F79	MYL., 0.1 μ F							

Symbol No.	Part No.	Description			Symbol No.	Part No.	Description		
Diodes									
D9101	48T84758F01	1SS270ATD			S9121	40T83324F01	Tact. SKHHAP (CHECK)		
or	48T58583F01	1SS176			S9122	40T83324F01	Tact. SKHHAP (PROG)		
D9102	48T84758F01	1SS270ATD			S9123	40T83324F01	Tact. SKHHAP (STOP)		
or	48T58583F01	1SS176			S9124	40T83324F01	Tact. SKHHAP (OPEN/CLOSE)		
D9103	48T84758F01	1SS270ATD			Miscellaneous				
or	48T58583F01	1SS176			C2001	08S40154T63	Capacitor, Ceramic 0.022 μ F		
D9104	48T84758F01	1SS270ATD			FL9101	65T83067F01	FL, Display		
or	48T58583F01	1SS176			HD2001	88T96209F01	Head, Optical Pick-Up		
D9105	48T84758F01	1SS270ATD			J6003	09T84775F02	Plate, PHRA-B		
or	48T58583F01	1SS176			M2001	01V11200W42	Assy., Loading Motor		
D9106	48T84758F01	1SS270ATD			M2001	01V94700F74	Assy., Slider Motor		
or	48T58583F01	1SS176			M2003	59T81431F01	Assy., Spindle Motor		
D9107	48T84758F01	1SS270ATD			○ P1001	28T43812P04	Plug, AC Cord		
or	48T58583F01	1SS176			△ P1001	28T70972F01	Plug, AC Cord		
LD9101	48T60947F05	LED, SLH-34VR3F (RED)			× P1001	28T70972F01	Plug, AC Cord		
LD9102	48T60947F07	LED, SLH-34DU3F (ORG)			※ P1001	28T70972F01	Plug, AC Cord		
Switches									
S9101	40T83324F01	Tact. SKHHAP (6)			● P1001	28T43812P04	Plug, AC Cord		
S9102	40T83324F01	Tact. SKHHAP (5)			■ P1001	28T66771F01	Plug, AC Cord		
S9103	40T83324F01	Tact. SKHHAP (4)			▲ P1001	28T70972F01	Plug, AC Cord		
S9104	40T83324F01	Tact. SKHHAP (3)			S2001	40T71025F01	Switch, Detecto (IN)		
S9105	40T83324F01	Tact. SKHHAP (2)			S2002	40T71025F01	Switch, Detector (OUT)		
S9106	40T83324F01	Tact. SKHHAP (+10)			S2003	40T71025F01	Switch, Defector (Limit)		
S9107	40T83324F01	Tact. SKHHAP (10)			○ S8102	40T80258F02	Switch, Voltage Select		
S9108	40T83324F01	Tact. SKHHAP (9)			● S8102	40T80258F02	Switch, Voltage Select		
S9109	40T83324F01	Tact. SKHHAP (8)			▲ T8101	25T95001F01	TRANS., Power		
S9110	40T83324F01	Tact. SKHHAP (PLAY)			● T8101	25T95065F01	TRANS., Power		
S9111	40T83324F01	Tact. SKHHAP (PAUSE)			■ T8101	25T95257F01	TRANS., Power		
S9112	40T83324F01	Tact. SKHHAP (NEXT)			○ T8101	25T95065F01	TRANS., Power		
S9113	40T83324F01	Tact. SKHHAP (BACK)			△ T8101	25T95001F01	TRANS., Power		
S9114	40T83324F01	Tact. SKHHAP (F.FWD)			× T8101	25T95001F01	TRANS., Power		
S9115	40T83324F01	Tact. SKHHAP (F.BWD)			※ T8101	25T95001F01	TRANS., Power		
S9116	40T83324F01	Tact. SKHHAP (REPEAT)							
S9117	40T83324F01	Tact. SKHHAP (1)							
S9118	40T83324F01	Tact. SKHHAP (7)							
S9119	40T83324F01	Tact. SKHHAP (T-DIS)							
S9120	40T83324F01	Tact. SKHHAP (CLEAR)							

Notes : ● : For West German model only (AD), ■ : For Japanese model only (JB), ▲ : For Canadian model only (UQ),
○ : For West German model only (AE), △ : For Canadian model only (UR), × : For North American model only (UZ),
※ : For North American model only (UV), Others : Common.

Cabinet Assembly Parts List

NOTE: The parts without part numbers are not supplied.

Symbol No.	Index	Part No.	Description	Symbol No.	Index	Part No.	Description
■	1	4-A 64D83886F09	Panel, Front	●	35	2-C 64B83869F01	Panel, Tray
▲	1	4-A 64D83886F11	Panel, Front	▲	35	2-C 64B83869F01	Panel, Tray
●	1	4-A 64D83886F11	Panel, Front	×	35	2-C 64B83869F01	Panel, Tray
○	1	4-A 64D83886F11	Panel, Front	■	35	2-C 64B10696W02	Panel, Tray
△	1	4-A 64D83886F11	Panel, Front	○	35	2-C 64B10696W02	Panel, Tray
×	1	4-A 64D83886F11	Panel, Front	△	35	2-C 64B10696W02	Panel, Tray
※	1	4-A 64D83886F11	Panel, Front	※	35	2-C 64B10696W02	Panel, Tray
	2	4-C 07C10035W01	Assy., Front Frame	36	4-D 47A83883F01	Shaft, Power	
	3	1-D 15C83872F01	Cover, Top	37	5-A 36A83870F01	Knob, Power	
▲	5	5-A 07D83863F02	Front, Frame	38	5-G 07A91046F01	Support, P.C. Board	
●	5	5-A 07D83863F02	Front, Frame	39		03S40018G08	Screw, Tapping (M3 × 8)
×	5	5-A 07D83863F02	Front, Frame	40		03S40012G98	Screw, Tapping (M3 × 8)
○	5	5-A 07D83863F08	Front, Frame	41	4-H 07A84472F01	Frame, Opt Jack	
△	5	5-A 07D83863F08	Front, Frame	42	2-C 75S72374F89	Cushion, Rubber	
※	5	5-A 07D83863F08	Front, Frame				
■	5	5-A 07D83863F08	Front, Frame				
	6	03S71031F04	Screw, Bind (M3 × 8)				
	7	2-D 03S71031F02	Screw, Bind (M2.6 × 8)				
	8	75A96563F01	Pad, Trannleg				
	9	2-H 16T82537F01	Cap, Pin Jack				
	10	4-G 01T92973F03	Assy., Connector				
	11	3-C 61A92731F01	Crystal, Lens				
	13	04S40070G59	Washer, Flat (M4.1)				
	17	3-D 43A41837U03	Spacer, LED				
	18	04S40071G14	Washer, Spring Lock (M4.1)				
	19	3-B 30T95003F01	Wire, Parallel (35P)				
	20	03A83946F01	Screw, Special (M3 × 35)				
	21	2-E 03S40018G06	Screw, Tapping (M3 × 16)				
	26	3-G 03C40121T05	Screw, W/Washer (M3 × 8)				
■	28	3-F 15C83873F17	Cover, Rear				
●	28	3-F 15C83873F20	Cover, Rear				
▲	28	3-F 15C83873F22	Cover, Rear				
○	28	3-F 15C83873F20	Cover, Rear				
△	28	3-F 15C83873F22	Cover, Rear				
×	28	3-F 15C83873F23	Cover, Rear				
※	28	3-F 15C83873F23	Cover, Rear				
	30	2-G 43B41625J02	Support, Cord				
	32	03S40036U01	Screw, W/Washer (M4 × 8)				
	33	4-D 43A83885F01	Spacer, Rubber				
	34	03S44205G52	Screw, Pan (M4 × 14)				

Notes: ● : For West German model only (AD), ■ : For Japanese model only (JB), ▲ : For Canadian model only (UC), ○ : For West German model only (AE), △ : For Canadian model only (UR), × : For North American model only (UZ), ※ : For North American model only (UV), Others : Common.

Exploded View (Cabinet)

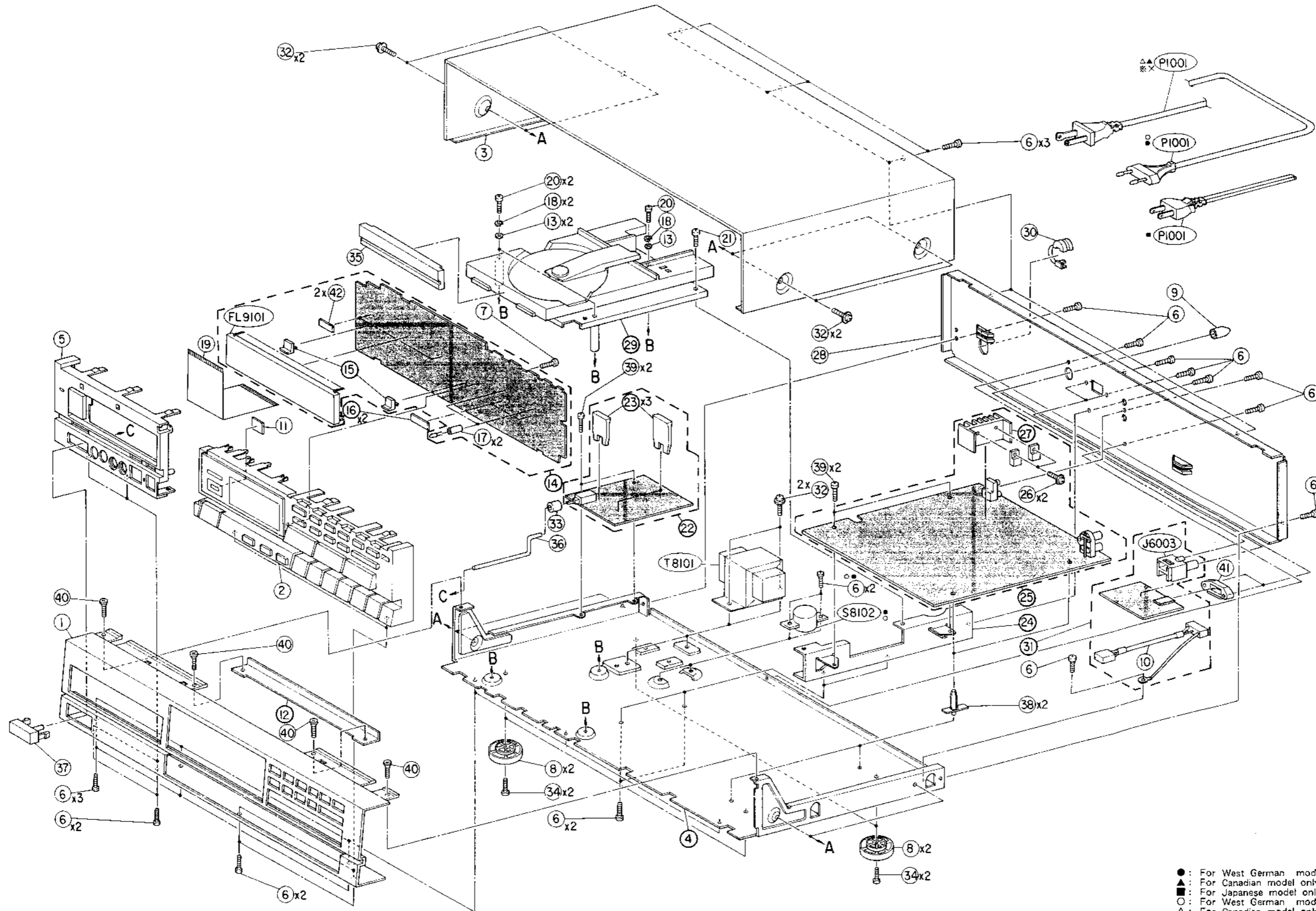

- : For West German model only (AD)
- ▲ : For Canadian model only (UO)
- : For Japanese model only (JB)
- : For West German model only (AE)
- △ : For Canadian model only (UR)
- × : For North American model only (UZ)
- ※ : For North American model only (UV)
- Others : Common

Exploded View (CD Mechanism)

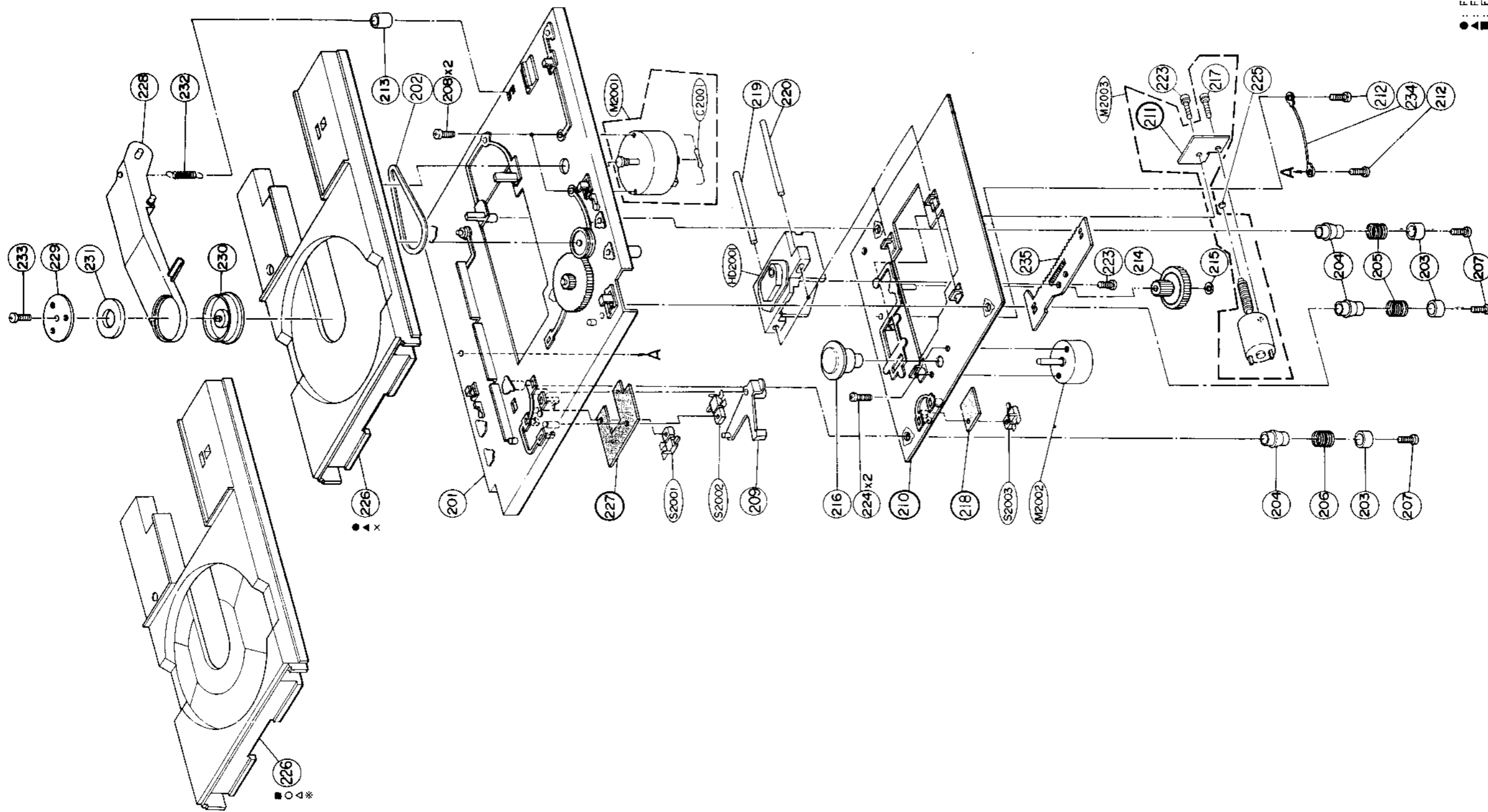

● : For West German model only (AD)
 ○ : For Canadian model only (UB)
 ▲ : For Japanese model only (JB)
 ○ : For West German model only (AE)
 △ : For Canadian model only (UR)
 X : For North American model only (UZ)
 ※ : Others: Common

CD Mechanism Assembly Parts List

Symbol No.	Index	Part No.	Description	Symbol No.	Index	Part No.	Description
201	4-C	01C82391F02	Assy., Main Chassis				
202	2-C	42A81427F02	Belt, Drive				
203		43A81407F01	Bush, Damper				
204		75A81411F01	Rubber, Damper				
205	3-H	41A81428F03	Spring, Compression				
206	4-H	41A81428F05	Spring, Compression				
207		03S40012G18	Screw, Tapping (M2.6 × 6)				
208	2-C	03D40014G19	Screw, W/Washer (M2.6 × 5)				
209	4-E	45A81434F01	Arm, Switch				
212		03S44205G30	Screw, Pan (M2.6 × 4)				
213	2-C	37S40133J18	Tube UL (20mm)				
214	3-G	44A81401F01	Gear, Worm Wheel				
215	3-G	04A41345P02	Washer, Lock (M1.7)				
216	4-E	49B96318F01	Table, Disc				
217	2-G	03D40014G62	Screw, W/Washer (M2 × 3)				
219	2-E	47A81426F01	Shaft, Head				
220	2-E	47A81426F02	Shaft, Head				
223		03C40121T31	Screw, W/Double Washer (M2 × 6)				
224	4-E	03D40014G07	Screw, W/Washer (M2 × 4)				
225	2-G	43A41182P02	Ball Steel				
● 226		01C81529F01	Assy., Tray Disc				
▲ 226		01C81529F01	Assy., Tray Disc				
× 226		01C81529F01	Assy., Tray Disc				
■ 226		01C10716W01	Assy., Tray Disc				
○ 226		01C10716W01	Assy., Tray Disc				
△ 226		01C10716W01	Assy., Tray Disc				
※ 226		01C10716W01	Assy., Tray Disc				
● 228	2-A	45C81418F01	Arm, Clamp				
▲ 228	2-A	45C81418F01	Arm, Clamp				
× 228	2-A	45C81418F01	Arm, Clamp				
■ 228	2-A	45C81418F04	Arm, Clamp				
○ 228	2-A	45C81418F04	Arm, Clamp				
△ 228	2-A	45C81418F04	Arm, Clamp				
※ 228	2-A	45C81418F04	Arm, Clamp				
229	3-A	07A81413F02	Bracket, Magnet				
230	3-B	49A81403F01	Wheel, Clamp				
231	3-A	59T81430F01	Magnet				
232	2-B	41B81429F02	Spring, Extension				
233	3-A	03S68555F17	Screw, Bind (M2 × 4)				
234	2-H	01T92483F01	Assy., Lug Wire 1P				
235	3-F	01A82323F01	Assy., Rack				

Notes : ● : For West German model only (AD), ■ : For Japanese model only (JB), ▲ : For Canadian model only (UQ),
○ : For West German model only (AE), △ : For Canadian model only (UR), × : For North American model only (UZ),
※ : For North American model only (UV), Others : Common.

Semi-Conductor Lead Identifications

MC7805 : IC1101

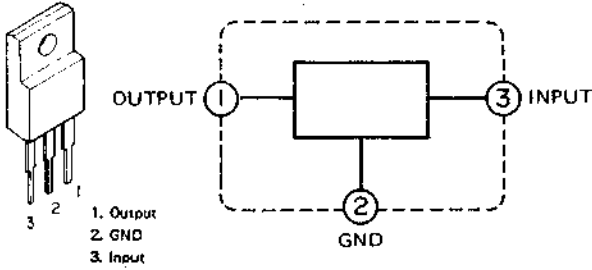

MC7905 : IC1102

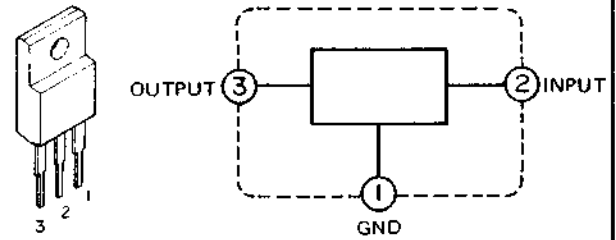

CXA1081S : IC1201

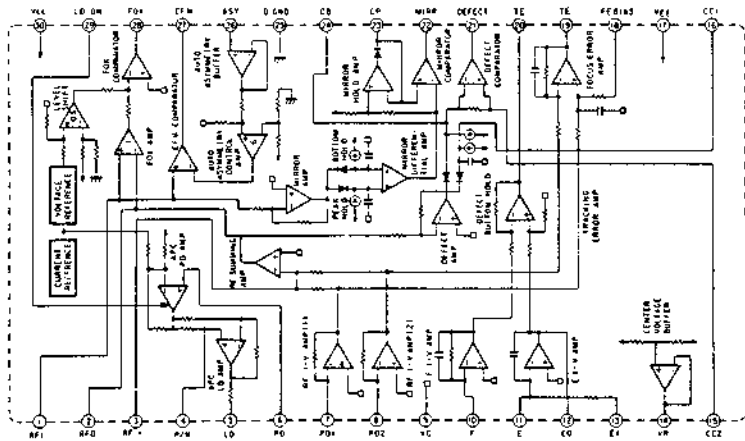
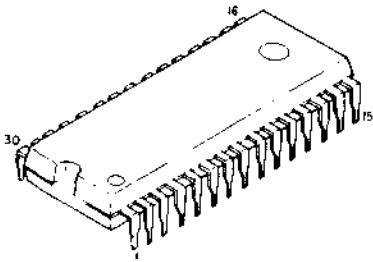

CXD1125QZ } : IC1202
CXD1135Q }

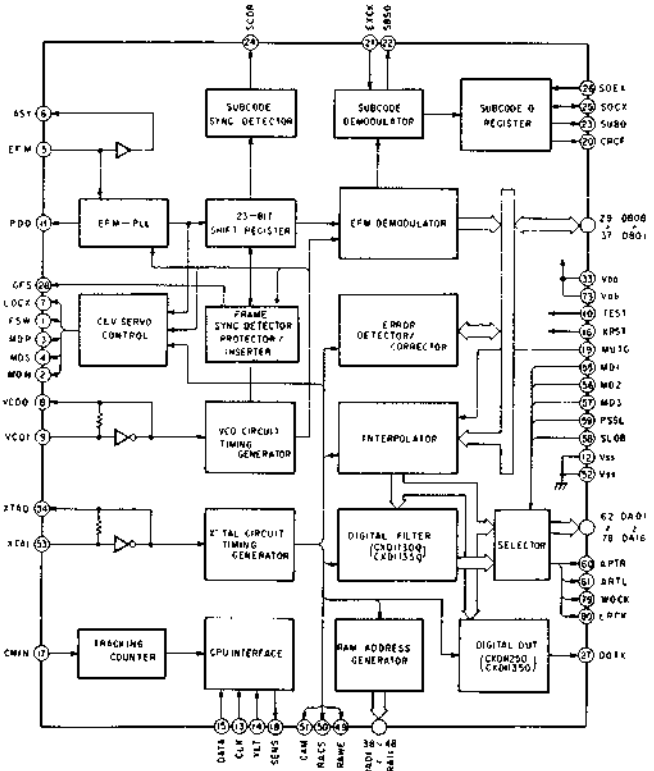
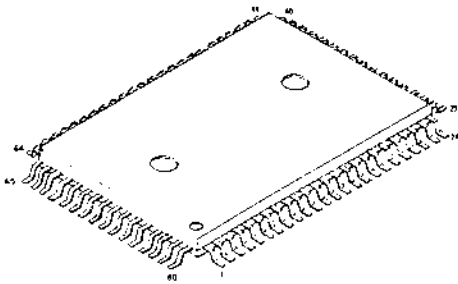

CXK5816SP : IC1203

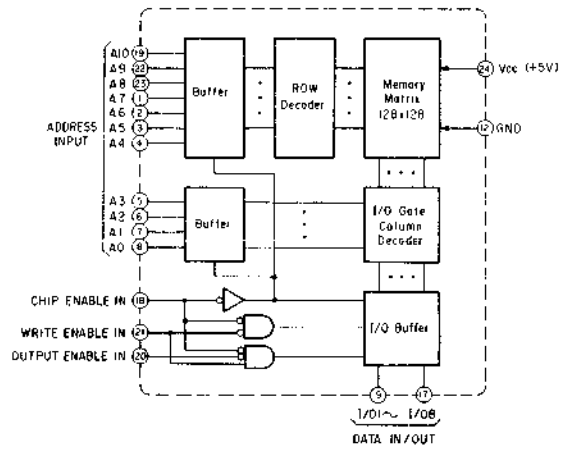
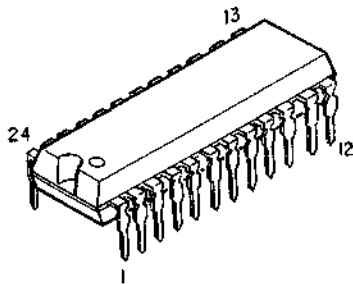

LC3516AS-15 : IC203

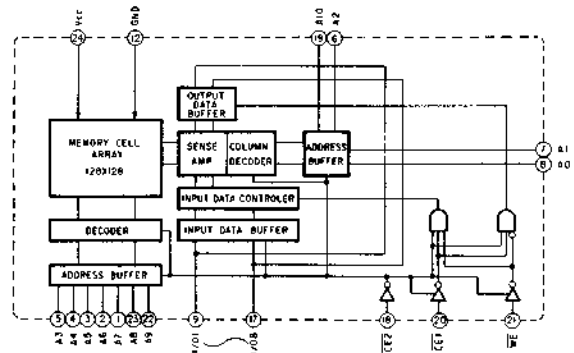
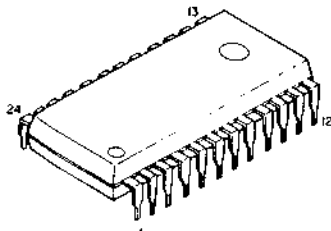

MC74HCU04 : IC1205

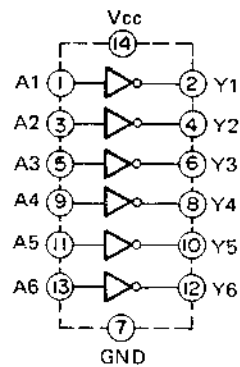
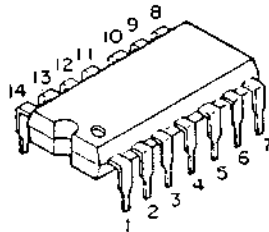

84097F01 : IC1204

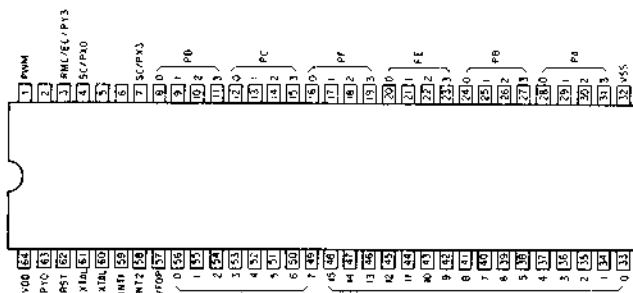
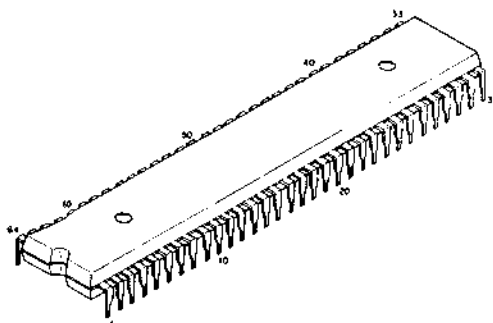

CXA1082A : IC1301

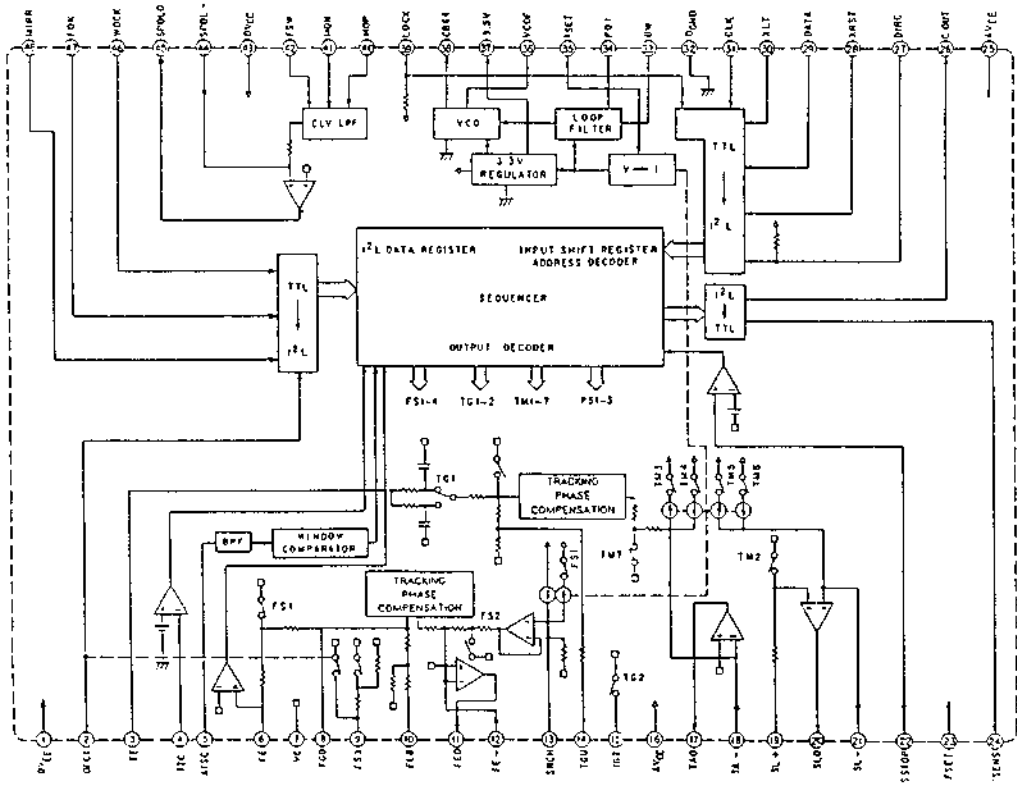
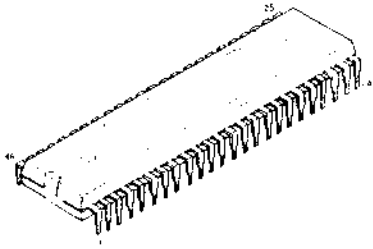

MC14053 : IC1302

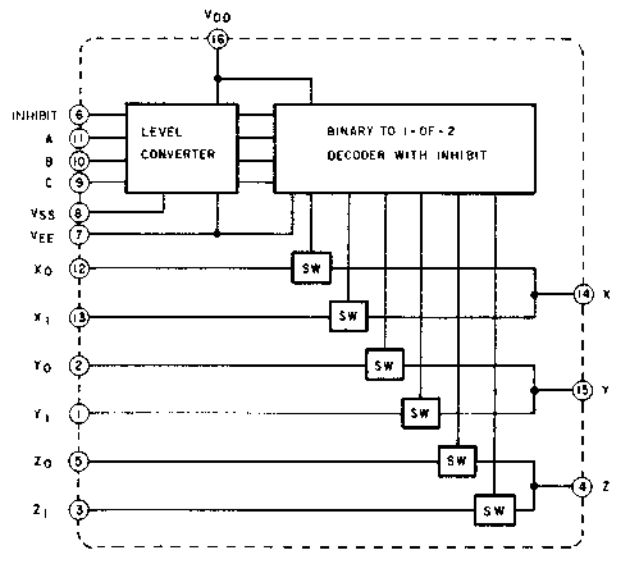
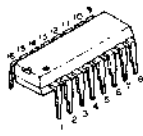

LA6501-LR : IC1502

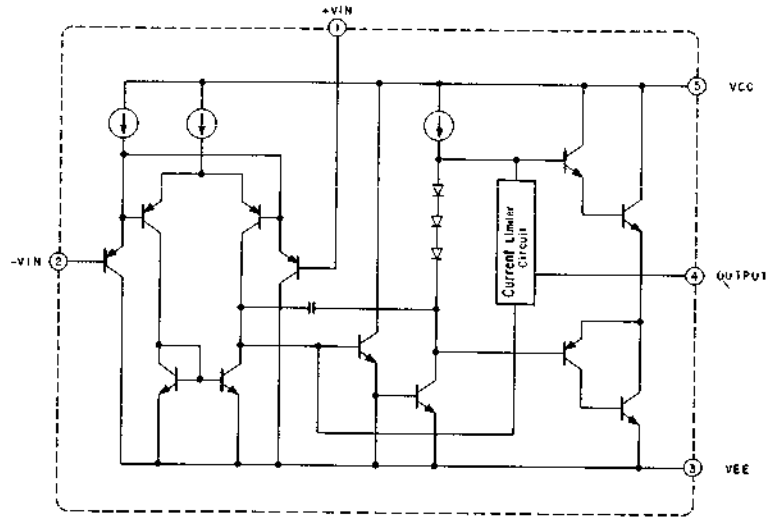
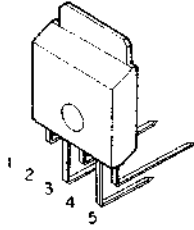

TOTX172 : IC6001

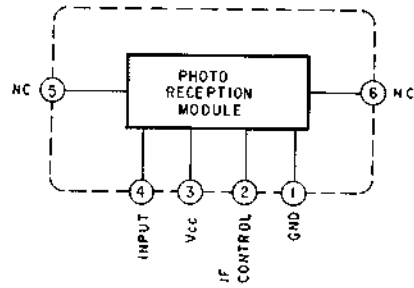
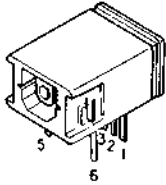

BX1387 : IC9101

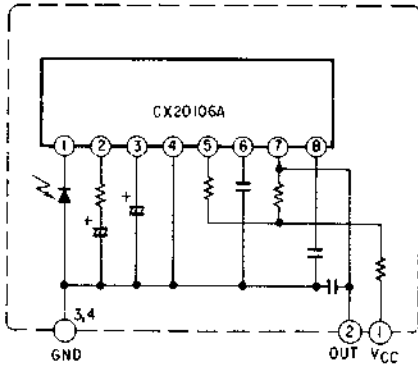
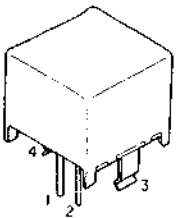

- 2SA1561 : Q1101
- 2SC4038 : Q1103
- 2SB1277 : Q1203, 1301, 1303, 1305, 1307
- 2SD1919TL4 : Q1302, 1304, 1306, 1308

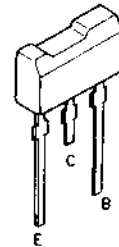

DTC114EL : Q1102, 1201, 1309, 1901, 1902

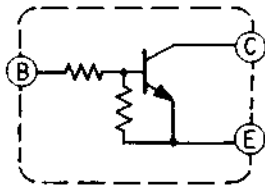
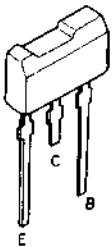

DTA114EL : Q1104

