

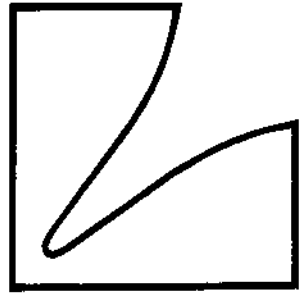

V19130

SERVICE MANUAL



Compact Disc Player

D-112

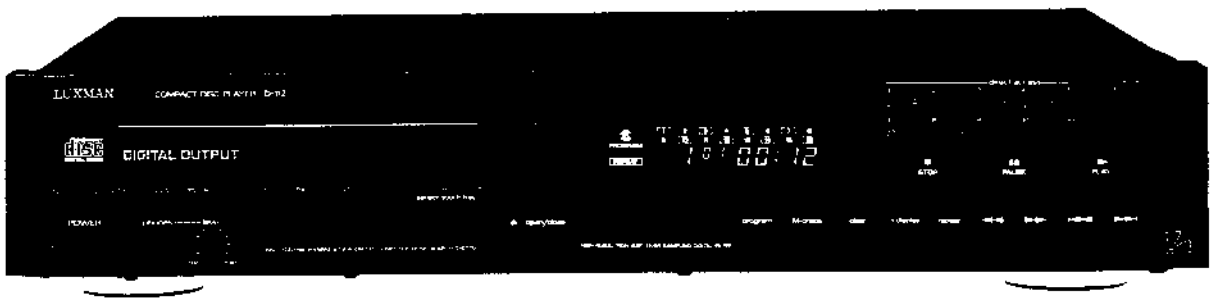

Contents

Specification	2
Controls & Switches Front Panel	3 to 4
Jacks & Terminals Rear Panel	5
Operation Guidelines	6 to 7
Disassembly Instructions	8 to 13
<Cabinet Section>	8
<Service Notes>	9 to 10
<CD Mechanism Section>	11 to 13
Adjustment Procedures	14 to 15
Adjustment Locations	16 to 17
Block Diagram	18
Parts Layout on P. C. Boards and Wiring Diagram (UQ/JA model only)	19 to 21
Parts Layout on P. C. Boards and Wiring Diagram (AD/UZ model only)	22 to 24
Schematic Diagram	25 to 27
Electrical Parts List	28 to 31
Packing Method View	32
Packing Assembly Parts List	32
Cabinet Assembly Parts List	33
Exploded View (Cabinet)	34 to 35
Exploded View (CD Mechanism)	36 to 37
CD Mechanism Assembly Parts List	38
Semi-conductor Lead Identification	39 to 43

Specifications

CD SECTION

System	Optical (Compact Disc System)
Quantizing Bit Number	16 Bit Linear System
Channels	2 Channel Stereo
Pickup	Semiconductor Laser Pickup
Output Voltage	2V ± 1dB
Frequency Response	20~20kHz +1dB, -2dB
T.H.D (1kHz)	0.001%
S/N	85dB
Dynamic Range	83dB
Separation (1kHz)	75dB
Headphone Output Voltage (1kHz, 20dB/8 ohm)	200mV ± 1dB
Power Supply	AC120/220/240V, 50Hz (AD model only) AC120V, 60Hz (UZ, UQ model only) AC100V, 50/60Hz (JA model only)
Power Consumption	12W
Semiconductors	14 IC's, 20 Transistors 24 Diodes, Zener Diodes
Dimensions (W × H × D)	438 × 85 × 314mm
Weight	4.3kg

COMPACT DISC

Track Pitch	1.6 μm
Modulation Frequency	44.1kHz
Transfer Rate	4.3218M Bit/Sec
Dimension	120 × 1.2mm

NOTE : Due to continuing product improvement, specifications and design are subject to change without notice.

CONTROLS & SWITCHES — FRONT PANEL

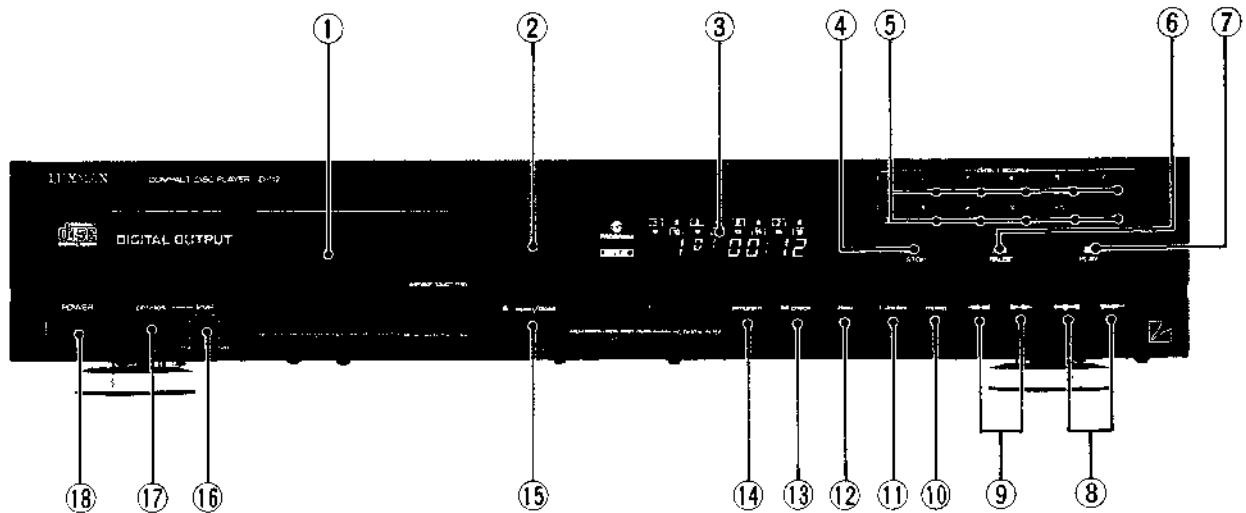

1. Disc Tray

Place the compact disc on this tray, label side up. A slight touch on the open disc tray will cause the tray to retract back into the unit for playback. Press the Open/Close Button to open or close the tray. When the tray is in the open position, push the tray gently to close the tray, or press any of Play, Pause and Stop buttons.

2. Remote Command Sensor

For remote control operation, the hand held remote control unit must be pointed toward the remote command sensor to initiate the control functions.

3. Display

The various operational and programming conditions are shown on the display. See Operation Guidelines, for detailed information.

4. Stop Button

Press this button once to stop playback and return the pickup to the beginning of the disc. While programmed playing, two pushes of the Stop Button will clear out any program in memory.

5. Track Select Buttons

These buttons are used for programming sequences for playback (In conjunction with the "Program" Button), and for direct access to selections on a disc.

6. Pause Button/Indicator

Press this button to temporarily stop playback. To resume playback, press this button a second time or press the "Play" button and playback will begin at the place where it was paused.

Note: Forward/Backward Skipping and Fast Forward/Fast Backward operations are still possible when in the Pause Mode.

7. Play Button/Indicator

Press this button to begin playback, initially as well as after programming a sequence. When playback begins, the indicator will light until playback is cancelled.

Note: The indicator will blink during Programming operations.

8. Forward/Backward Skip Switches

Press the Forward Skip Button (▶▶) once to skip to the beginning of the next track ahead on the disc. Successive pushes will skip ahead, one track at a time. When you reach the last selection on the disc, another push of this button will bring you back to the very first selection.

Press the Backward Skip Button (◀◀) once to return to the beginning of the track currently being played. Successive pushes on this button will skip the pickup backward, one track at a time, to the beginning of the disc.

CONTROLS & SWITCHES — FRONT PANEL

9. Fast Forward/Fast Backward Buttons

Press these buttons to move the pickup fast forward or fast backwards.

Note: When these buttons are pressed while in "Pause" mode, the pickup will move faster than when in "Play" mode.

10. Repeat Button

In normal Play mode, push this button to repeat all tracks on a disc. In programmed play mode, press this button to repeat only those tracks that have been programmed. To cancel the repeat function, press the Repeat Button a second time, and playback will continue until the end of the disc or programmed sequence, then stop.

11. Display Time Select Button

Each push of this button displays one of two time displays:

"Single Elapsed" — Time elapsed since beginning of current track. This occurs with "REMAIN" indicator OFF.

"Total Remain" — Play time remaining on entire disc. This occurs with "REMAIN" indicator ON.

Note: If any of the four buttons, Fast Forward, Fast Backward, Forward Skip and Backward Skip buttons, is pressed while in "Program Play" mode, the "Remain" indicator does not display.

12. Clear Button

Press this button to clear out programmed tracks, beginning with the last track programmed.

Note 1: With each successive push of the Clear Button, the red frame surrounding the last programmed track will disappear.

Note 2: This function will only work in the Stop mode.

13. Memory Check Button

Use this button to check the order of selections that have been programmed.

With each successive push of the button, the program number will show on the display under P. No. (the rest of the display will turn off).

Note: This function will only work in the Stop mode.

14. Program Button

Use this button in conjunction with the Track Select Button to program tracks. (See Operation Guidelines for details.)

To cancel the program mode, press the Program Button a second time, or press the Stop Button twice.

15. Open/Close Button

Push this button to open and close the disc tray.

16. Phones Level Control

Use this control to adjust the output level for the stereo headphones.

17. Phones Jack

Use this jack to connect stereo headphones. The output level can be adjusted by the Phones Level Control.

18. Power Button

Push this button to turn the unit power on and off.

Note: If a disc is already located in the tray when the power is turned on, the unit will automatically start playback, beginning with track 1.

JACKS & TERMINALS — REAR PANEL

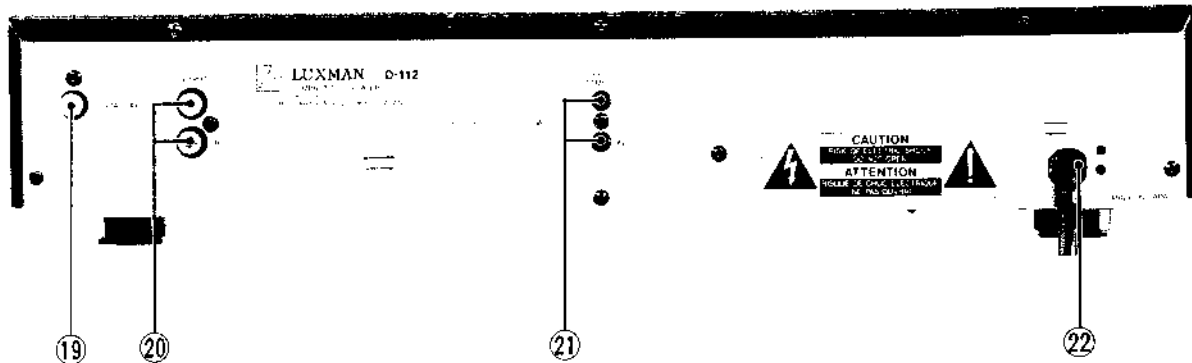

19. Digital Output Terminal

This digital output terminal is to be connected to the digital input terminal on an amplifier such as the LV-117 for direct digital transmission. This eliminates distortion inherent in analog connections and improves the dynamic range and frequency response of the digital source signals.

20. Output Terminals

Use these terminals to connect to the CD inputs on an amplifier. The output voltage level for these terminals is fixed at 0 dB (2Vrms).

21. Serial Remote In/Out Jacks

Use these jacks for a simple and convenient connection of other Luxman components for Remote Control operation. Connect the Serial Remote In and Out jacks to the Serial Remote Out and In jacks, respectively, on other Luxman components (in daisy chain fashion), for a unified remote control system.

Note: Turn the power off before connecting these jacks.

22. Power Cord

This high grade power cord is used in order to guarantee high sound quality. Plug the cord directly into the wall outlet or into an AC outlet on an amplifier that also has a high grade power cable.

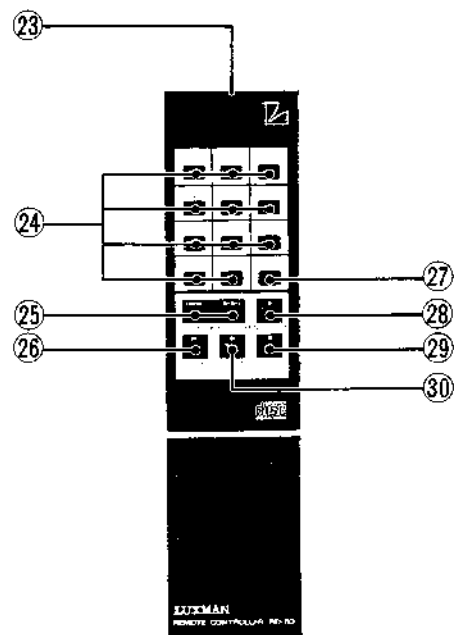

REMOTE CONTROLLER RD-113

* Operation is the same as for the buttons on the set.

23. Transmission Window

24. Track Select Buttons

25. Forward/Backward Skip Buttons

26. PLAY Button

27. REPEAT Button

28. OPEN/CLOSE Button

29. STOP Button

30. PAUSE Button

OPERATION GUIDELINES

Turn the power on to the components to be used.
Turn the volume of the amplifier fully down, then adjust it to a suitable level just prior to playback.
Push the Open/Close Button on the D-112 and set the disc on the tray, label side up.

NORMAL PLAY

1. After the disc is loaded, press the Play Button.
2. Playback will begin from the first track number, continuing on through the remaining tracks. As each track is completed, the number corresponding to it on the display will turn off.
Note: If the Repeat function is on, these numbers will not turn off on the display.
3. Playback automatically stops after the last track on the disc is played (unless in Repeat mode).

Examples:

In Figure 1, all the track numbers are displayed and the track about to be played is displayed as 1 near the "DISC" symbol.

In Figure 2, tracks 1 through 9 have already been played back, and track 10 is currently in playback. The number 10 is displayed near the "DISC" symbol. ()

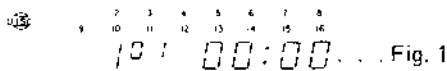

Fig. 1



Fig. 2

Direct Access

1. Use the Track Select Buttons to specify a desired track.
2. All track numbers before this track will be cleared from the display, and playback will begin immediately.
Note: If the Repeat Button function is on, the track numbers will not be cleared from the display. The pickup will move to the desired track and begin playback, then continue through all the tracks remaining on the disc. It will then go back to the beginning of the disc and repeat.
3. Playback will stop automatically after the last track is played.

* Direct Access to the 10th Track

Press either Track Select Button "10" or "+10" then press the Play Button.

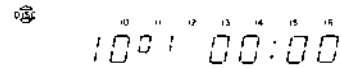

* Direct Access to the 11th Track to the 19th Track

Press the Track Select Buttons "+10" and the number (1 through 9).

Example: For direct access to the 17th track, press "+10" and "7".

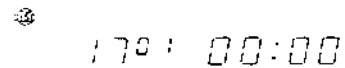

* Direct Access to the 20th Track

Press the Track Select Buttons "+10" and "10" or "+10" twice and press the PLAY Button.

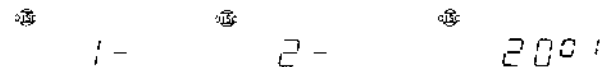

* Direct Access to the 21st Track and Above

Press the Track Select Button "+10" twice, then press the number (1 — 9).

Example: For direct access to track 26, press "+10", "+10" and "6".

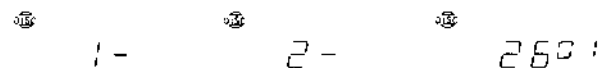

- * Direct access will be cancelled if a Track Select Button other than "+10", the Play Button, or the Pause Button is not pressed within 4 seconds after pressing "+10".

The "+10" Button will not operate with discs containing 10 or fewer tracks.

OPERATION GUIDELINES

PROGRAMMED PLAY

Programming

1. Press the Program Button. "PROGRAM" will appear on the display. Choose a track number using the Track Select Buttons. A red frame will light around that track number, and every other track number you program subsequently.

Note: For programming a track number higher than 10 on the disc, follow the instructions under "Programming" for selecting the track number.

Note: Do not press the Play Button while programming.

2. A maximum of 16 tracks can be programmed. If an attempt is made to program a 17th track, "FULL" will appear on the display for approximately 4 seconds, indicating that no more tracks can be programmed.
3. Programmed playback will begin immediately after the Play Button is pressed.

Note: Programming can only be done in the Stop mode.

Example for Programming Tracks 11, 3, 5, 15 and 16

1. Press the Program Button.
2. Specify tracks 11, 3, 5, 15 and 16 using the Track Select Buttons.
(Press "+10"—"1", "3", "5", "+10"—"5", and "+10"—"6".)
3. Playback stops once all programmed tracks have been played.
4. The red frame around each track number will disappear as that track is played. All remaining tracks will have a frame around them.

Note: If the Repeat Button has been pressed "REPEAT" will be displayed and none of the frames will be cleared around the track numbers. Only those tracks programmed will be repeated.



The total time for the programmed tracks will be displayed.

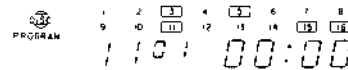

Clearing Programs

1. To clear program for memory, you must be in Stop mode. Simply press the Clear Button once for each track number you wish to clear.

Note: Clearing will begin with the last track programmed.

2. To clear the entire program, either press the program button a second time or press the Stop Button.

Repeat

When the Repeat Button is pressed during normal playback, all tracks on the disc will be repeated continuously.

If the Repeat Button is pressed during programmed playback, all programmed tracks will be repeated continuously.

To cancel the Repeat mode, press the Repeat Button a second time and playback will continue to the end of the disc then stop, or press the Stop Button and playback will stop immediately.

Disassembly Instructions

< Cabinet Section >

1. Removal of CD Mechanism

- (1) Open the disc tray.
- (2) Remove the tray panel in the arrow direction as shown in Figure 2.
- (3) Remove four screws marked "O" as shown in Figure 1.
- (4) Disconnect all wires from the CD Mechanism.

1. CDメカニズムの外し方

- (1) ディスク・トレイをオープンにします。
- (2) トレイ・パネルを矢印の方向に外します。(2図参照)
- (3) 4本のネジ (O印) を外します。(1図参照)
- (4) CDメカニズムから出ている全てのリード線を外します。

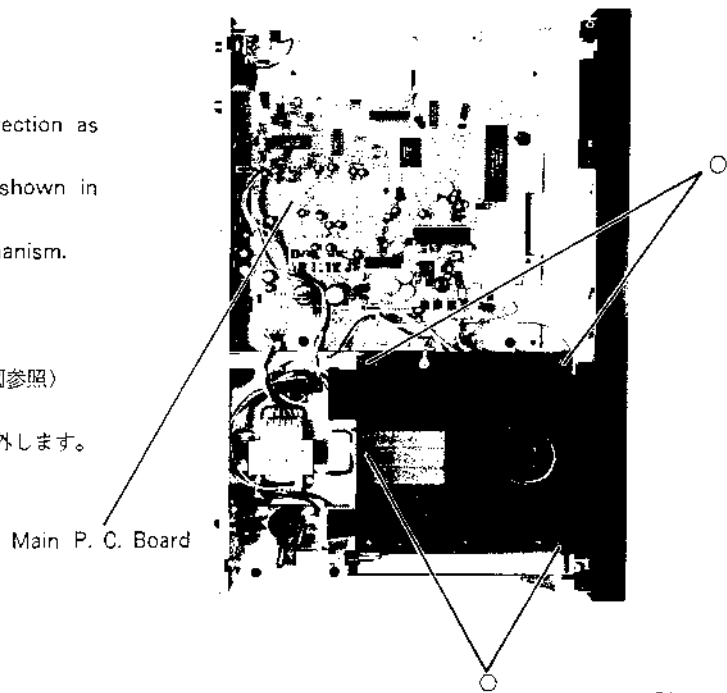

Figure 1
<1図>

2. Removal of FL/KEY Board P. C. Board

- (1) After removal of front panel, remove one screw marked "X" as shown in Figure 3.
- (2) Remove thirteen hooks as shown in Figure 3.
- (3) Disconnect one connector from the FL/KEY Board P. C. Board.

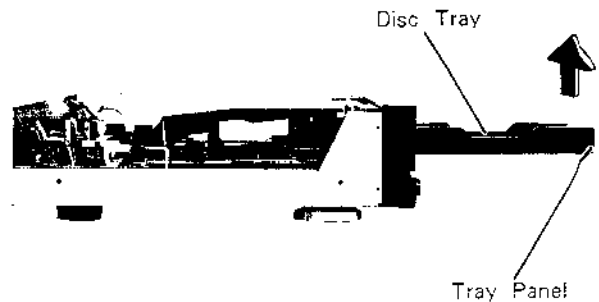

Figure 2
<2図>

2. FL/KEY Board 基板の外し方

- (1) フロント・パネルを外してから、1本のネジ (X印) を外します。(1図参照)
- (2) 13箇所のフックを外します。(3図参照)
- (3) FL/KEY Board 基板から出ている1本のコネクタを外します。

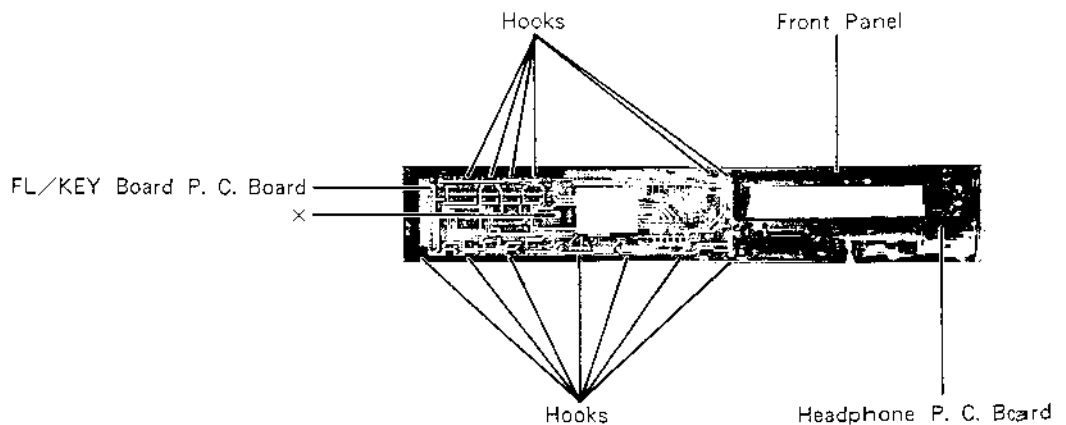

Figure 3
<3図>

<Service Notes>

1. Notes on Laser Diode Emission and Focus Search Operation Check

(1) Caution when checking Laser Diode emission.

The laser beam on this model is concentrated so as to be focused on the disc reflective surface by the objective lens in the optical pick-up block. Therefore, when checking the laser diode emission, observe from more than 30 cm away from the objective lens.

(2) Check of the Laser Diode And Focus Search Operation

With no disc loaded and the disc tray closed, when switching the power on, check that the operation as shown in the below Figure 4 is performed, by observing the objective lens.

- ① Laser beam emits spreadingly.
- ② The objective lens perform up-and-down three times.

1. レーザーダイオードおよびフォーカスサーチ動作の確認

(1) レーザーダイオードの発光確認時の注意

本機のレーザー光は、光学系ピックアップ内の対物レンズによってディスクの反射面上に焦点を結ぶように集光されています。したがって、レーザーダイオードの発光を確認する時は、対物レンズより30cm以上目を離して下さい。

(2) レーザーダイオードおよびフォーカスサーチ動作のチェック方法

ディスクを入れないでディスクトレイが閉じた状態から、POWERスイッチをONさせた時、対物レンズおよび光学系ピックアップを見て、下の様な動作が行なわれるか確認する。(4回参照)

- ① レーザー光の拡散した、赤い色の光が見える。
- ② 対物レンズの上下運動。(3回)

Remove the Clamp Arm
(See Disassembly Instruction of Clamp Arm)
クランプアームを取り除く
(クランプアームの分解方法の項参照)

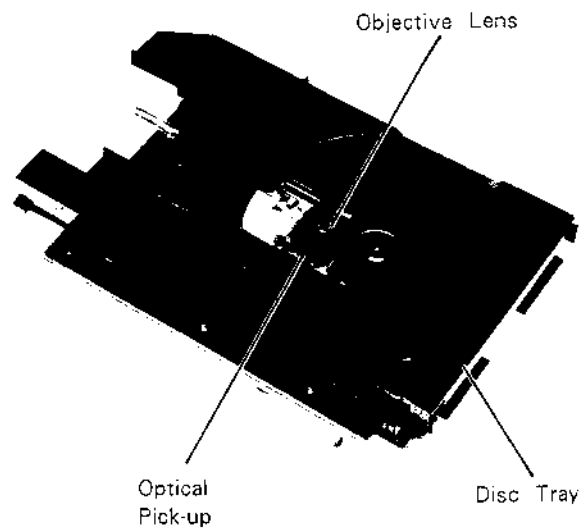

Figure 4
<4図>

2. Caution For Electrostatic Breakdown

[Notes on Handling The Base Unit (KSS-152A)]

The laser diode in the optical pick-up block may suffer electrostatic breakdown because of the potential difference generated by the charged electrostatic load, etc, on clothing and the human body.

The following notes are examples for reference purposes :

- ① Perform repair with ground ring on the hands and a conductive gum mat.
- ② Grasp the slide base when handling.
- ③ When removing the pickup arm shortcircuit by soldering as shown in the Figure 5 below and then remove the connector.
- ④ When mounting the pickup arm, after inserting the connector, remove the soldered shortcircuiting.

Notes : For making and removing the shortcircuit, be sure to use an iron with its metal part grounded or its insulation resistance is higher than 10M ohms (DC 500V), and the tip temperature is lower than 320°C. The soldering and desoldering should be made quickly.

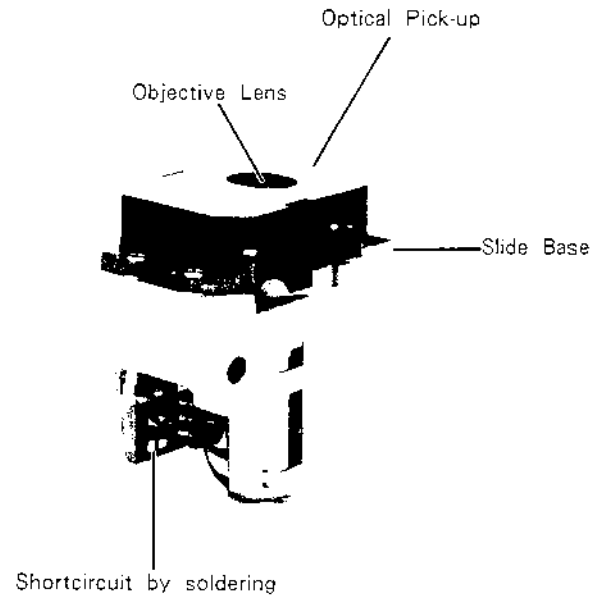

Figure 5
<5図>

2. 静電破壊についての注意

[KSS-152A (光学系ピックアップ) 取扱時の注意]

光学系ピックアップ内のレーザーダイオードは、衣服や人体に帯電した静電荷等で電位差を生じることにより、静電破壊することがあります。静電破壊に対する注意として下記のこと十分に注意して取扱ってください。

- ① 取扱い時には、人体アースおよびアースマットを用いて接地してから作業を行ってください。
- ② 取扱いは、スライドベースを持って行って下さい。
- ③ 取りはずす時、5図のように半田ショートさせてから、コネクタを外して下さい。
- ④ 取付け時、コネクタを差し込んだ後、半田ショートの部分を開放して下さい。

注意) 半田ショートおよび開放時には、金属部分を接地させた半田ゴテか、もしくは通電5分後の絶縁抵抗が10MΩ以上 (DC500V) のもので、コテ先温度が320℃以下の半田ゴテかを使用してすみやかに行って下さい。

<CD Mechanism Section>

1. Removal of Disc Tray

- (1) Pull out the disc tray in the arrow direction by pressing slant position of the disc tray as shown in Figures 6 and 7.
- (2) After disengaging one claw (A), remove the switch arm as shown in Figure 8.
- (3) Spread two claws (B) toward outside at the both sides of the disc tray and draw out the disc tray as shown in Figure 7.

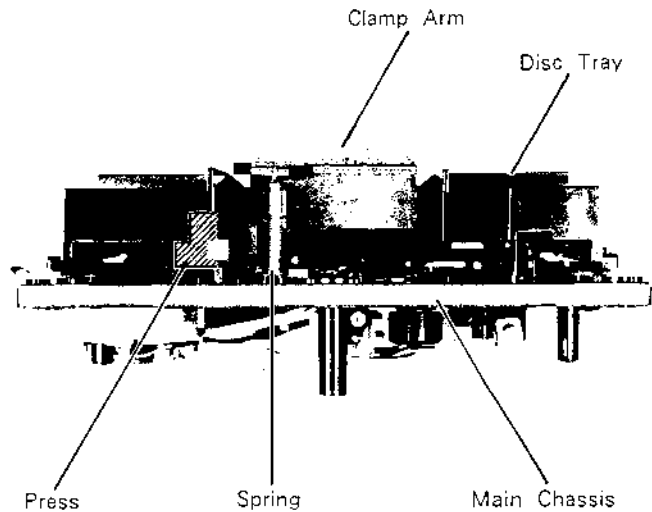

Figure 6

<6図>

1. ディスクトレイの外し方

- (1) ディスクトレイの斜線部分を押し、ディスクトレイを矢印方向に引き出す。(6、7図参照)
- (2) 爪 (A) を外し、スイッチアームを外します。(8図参照)
- (3) ディスクトレイ両サイドの爪 (B) を両外側に押し広げてディスクトレイを引き抜きます。(7図参照)

2. Removal of Clamp Arm

- (1) Remove one spring between the main chassis and the clamp arm as shown in Figure 6.
- (2) After pulling out the disc tray frontward, remove the clamp arm by pressing one claw (C) as shown in Figure 7.

2. クランプアームの外し方

- (1) メインシャーシとクランプアームとを止めているバネを外します。(6図参照)
- (2) ディスクトレイを前面に引き出した後爪 (C) を押しながらクランプアームを外します。(7図参照)

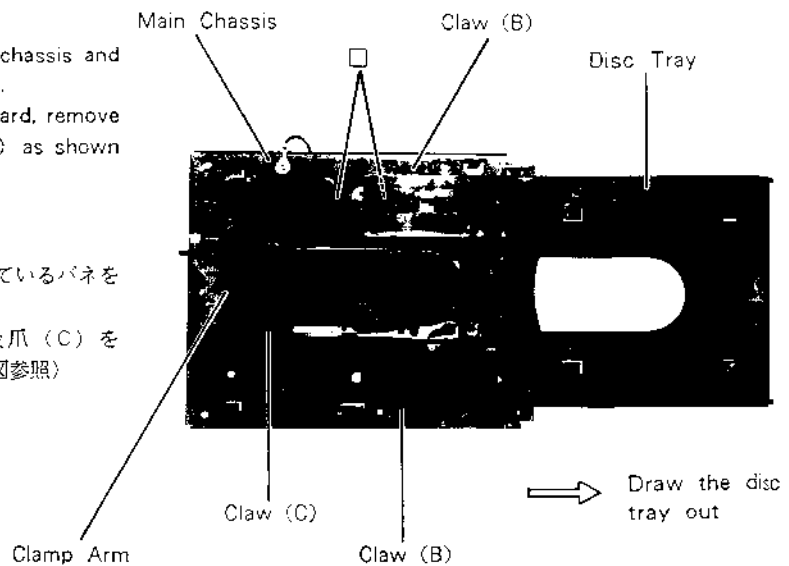

Figure 7

<7図>

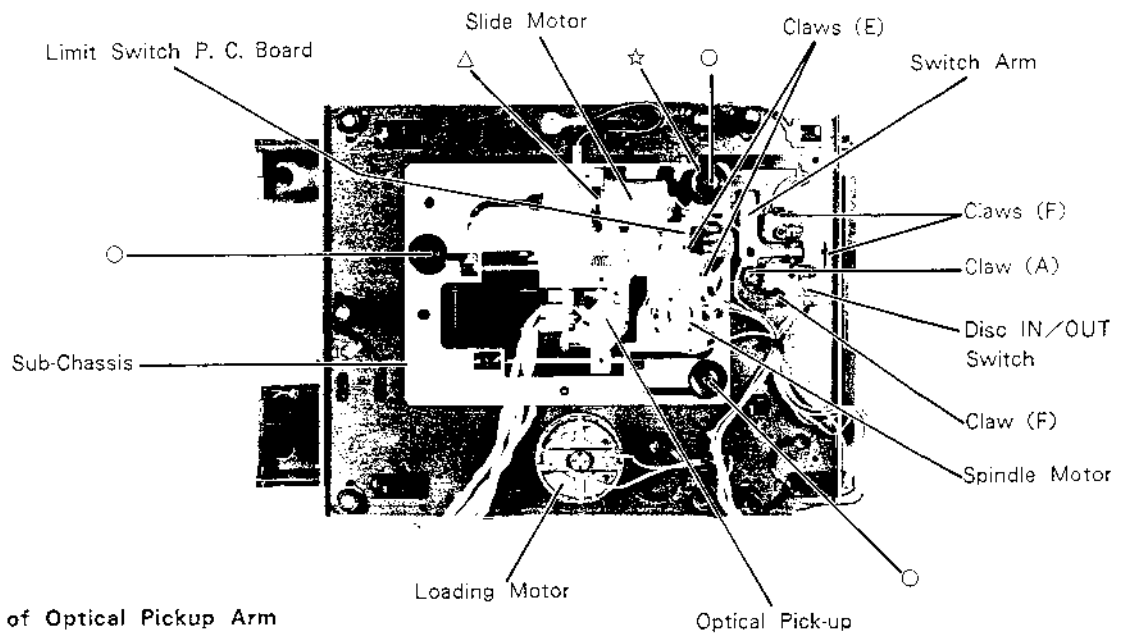

Figure 8

< 8図 >

3. Removal of Optical Pickup Arm

(1) After removing three screws marked "O", remove the sub-chassis as shown in Figure 8.

Note: When three screws are removed, three springs (one is black) appear under the damper bush. When assembling the sub-chassis put the black spring into the place marked "☆".

(2) While pressing two claws (D) in toward pull out two shafts in the arrow direction as shown in Figure 10.

3. 光学系ピックアップの外し方

(1) 3本のネジ (O印) を外し、サブシャーシを外します。

注意: 3本のネジを外すとそれぞれのダンパーブッシュの下に3本のバネ (内1本が黒色) があります。サブシャーシ取り付け時には、黒色バネを"☆"色の部分に入れて取り付けて下さい。(8図参照)

(2) 2ヶ所の爪 (D) を両方共に内側に押しながら、2本のシャフトを矢印の方向に引き抜きます。(10図参照)

4. Removal of Spindle Motor

(1) By grasping plastic part, lift the disc table straight up without applying pressure to metal part.

Note: For assembling the disc table, insert the disk table with pressure so that the height from the disc table top to the sub-chassis surface becomes 19.9 ± 0.1 mm in Figure 11.

(2) Remove two screws marked "X" as shown in Figure 10.

4. スピンドルモーターの外し方

(1) ディスクテーブルを金属部分に負荷をかけないで樹脂の部分をつかみまっすぐ上に引き抜きます。

注意: ディスクテーブルの組立て時、サブシャーシ上面からディスクテーブルの上面までの高さ 19.9 ± 0.1 mm の位置に左入して下さい。(11図参照)

(2) 2本のネジ (X印) を外します。(10図参照)

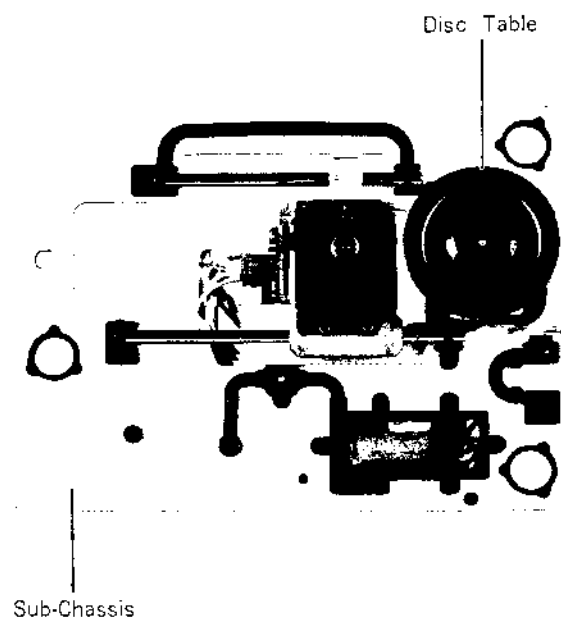

Figure 9

< 9図 >

5. Removal of Slide Motor

- (1) Remove one screw marked "△" and lift up the motor as shown in Figure 8.

5. スライドモーターの外し方

- (1) 1本のネジ(△印)を外し、上に持ち上げます。
(8図参照)

6. Removal of Loading Motor

- (1) Remove one belt and two screws marked "□" as shown in Figure 7.

6. ローディングモーターの外し方

- (1) ベルトを外し、2本のネジ(□印)を外します。
(7図参照)

7. Removal of Limit Switch P. C. Board

- (1) Remove two claws marked "E" as shown in Figure 8.

7. リミットスイッチ板の外し方

- (1) 2ヶ所の爪(E)を外します。(8図参照)

8. Removal of Disc IN/OUT Switch P. C. Board

- (1) Remove three claws marked "F" as shown in Figure 8.

8. ディスク IN/OUT スイッチ基板の外し方

- (1) 3ヶ所の爪(F)を外します。(8図参照)

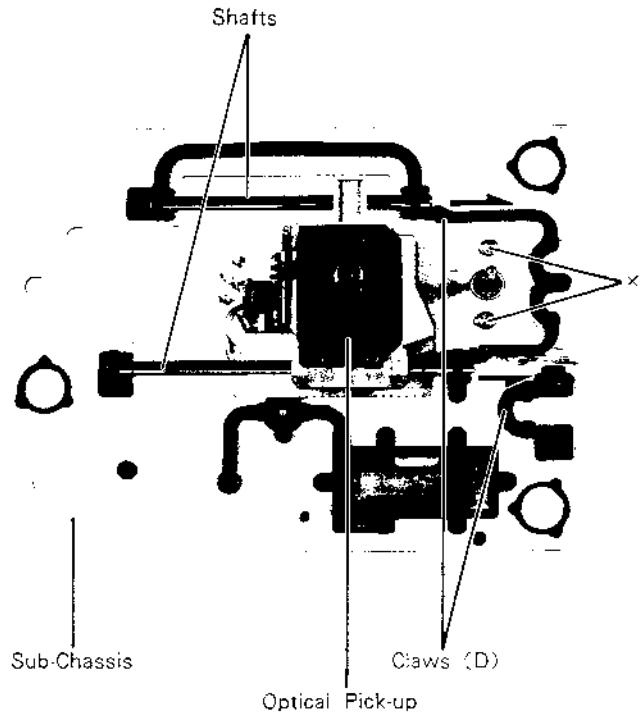

Figure 10

<10図>

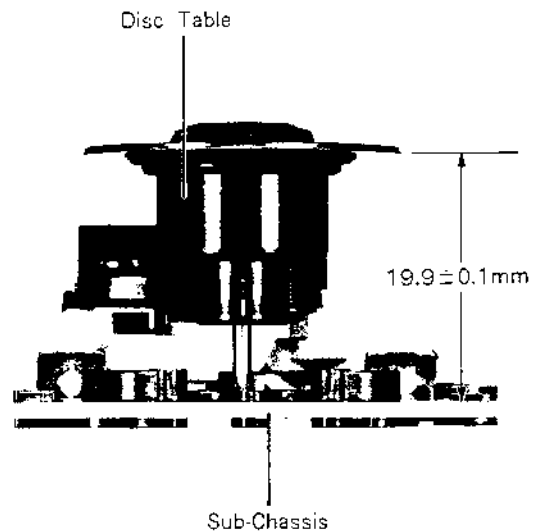

Figure 11

<11図>

Adjustment Procedures

1. Compact Disc Section

(1) Connections

(1) 接続図

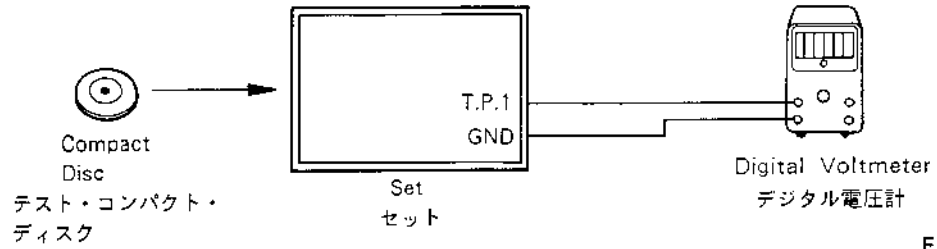

Figure 12
<12図>

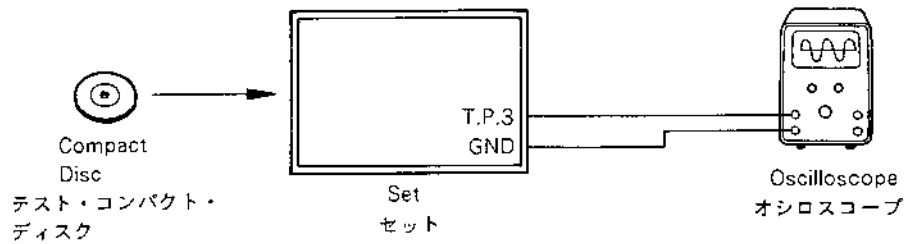

Figure 13
<13図>

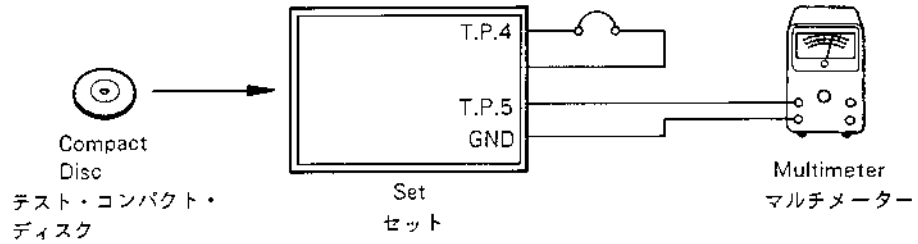

Figure 14
<14図>

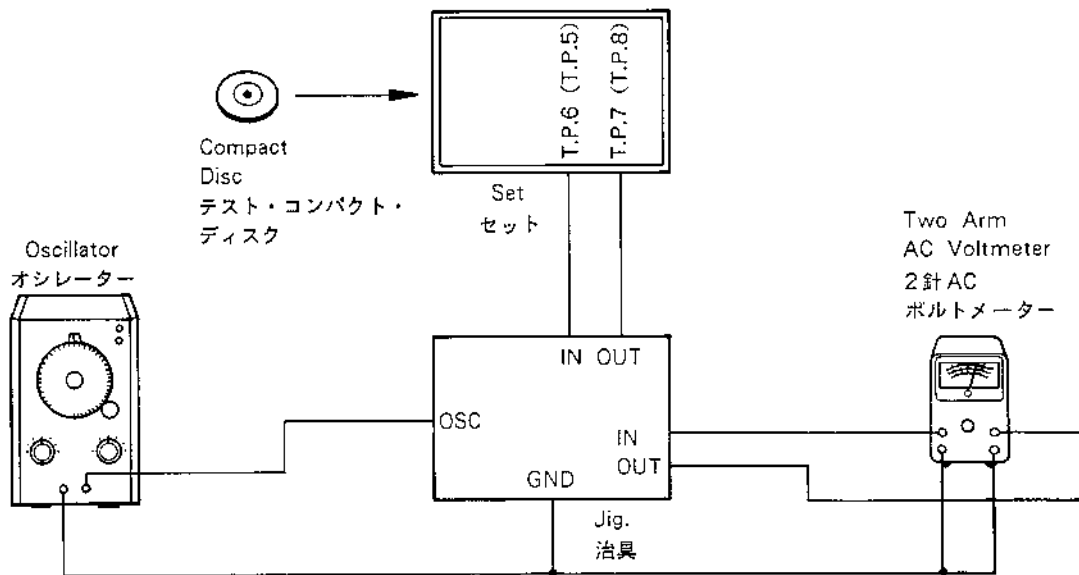

Figure 15
<15図>

(2) Adjustment Procedures

Step	Description	Connections	Oscillator	Test Point	Adjustment
1	VCO Adjustment	Figure 12	-	T.P.1	Connect two 100k ohm resistors between +V _{DD} to +V _{DD} and Ground of R1216 as shown in Figure 16 and adjust VR1303 so that the voltage is 2.5V.
2	Focus Bias Adjustment	Figure 13	-	T.P.3	Adjust VR1202 so that the oscilloscope shows the waveform amplitude maximum.
3	Tracking Error Balance Adjustment	Figure 14	-	T.P.4 T.P.5	After shortcircuiting T.P.4 and turning VR1301 fully counterclockwise, adjust VR1201 so that the voltage is 0V±50mV. After the adjustment set VR1301 to its center position.
4	Tracking Gain Adjustment	Figure 15	1kHz 200mV	T.P.6 T.P.7	Adjust VR1302 so that both arms of the voltmeter come at the same position.
5	Focus Gain Adjustment	Figure 15	1kHz 200mV	T.P.5 T.P.8	Adjust VR1301 so that both arms of the voltmeter come at the same position.

(2) 調整方法

順序	調整項目	接続図	オシレーター	テストポイント	調整方法
1	VCO調整	12図	-	T.P.1	R216のV _{DD} 間とGND間に100kΩ抵抗2個を16図のように接続して、電圧が2.5Vになる様にVR1303で調整します。
2	フォーカスバイアス調整	13図	-	T.P.3	オシロスコープの波形が最大になる様にVR1202で調整します。
3	トラッキングエラーバランス調整	14図	-	T.P.4 T.P.5	T.P.4をショートしてVR1301を左にしぼり電圧が0V±50mVになる様にVR1201で調整します。調整後、VR1301を中央付近にもどす事。
4	トラッキングゲイン調整	15図	1kHz 200mV	T.P.6 T.P.7	2針バルボルの針が重なる様にVR1302で調整します。
5	フォーカスゲイン調整	15図	1kHz 200mV	T.P.5 T.P.8	2針バルボルの針が重なる様にVR1301で調整します。

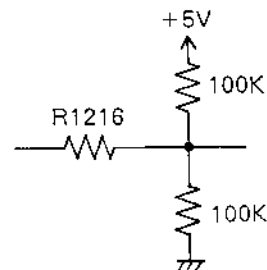
Figure 16
<16図>

Adjustment Locations

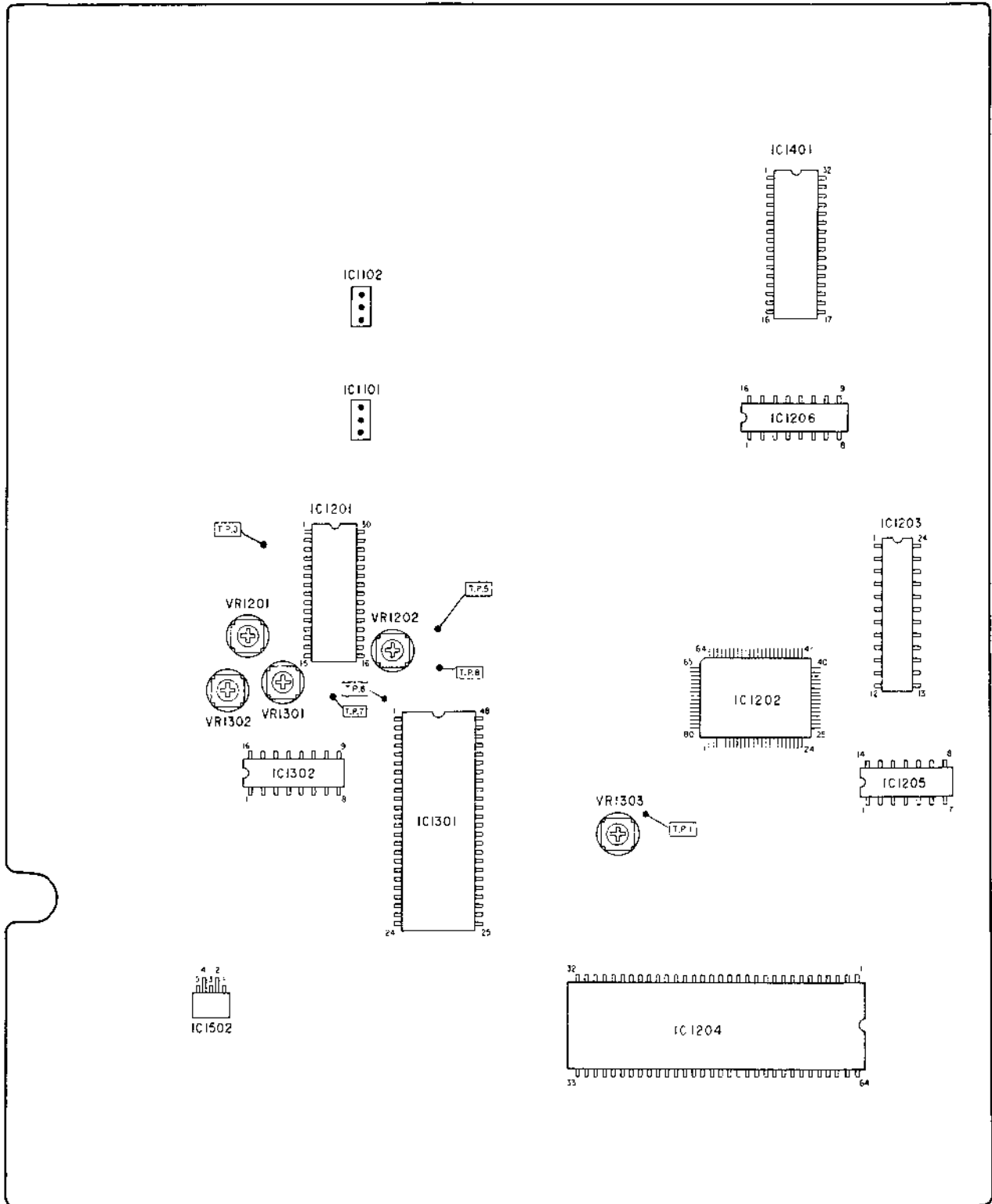

Main P. C. Board
(UQ/JA model only)

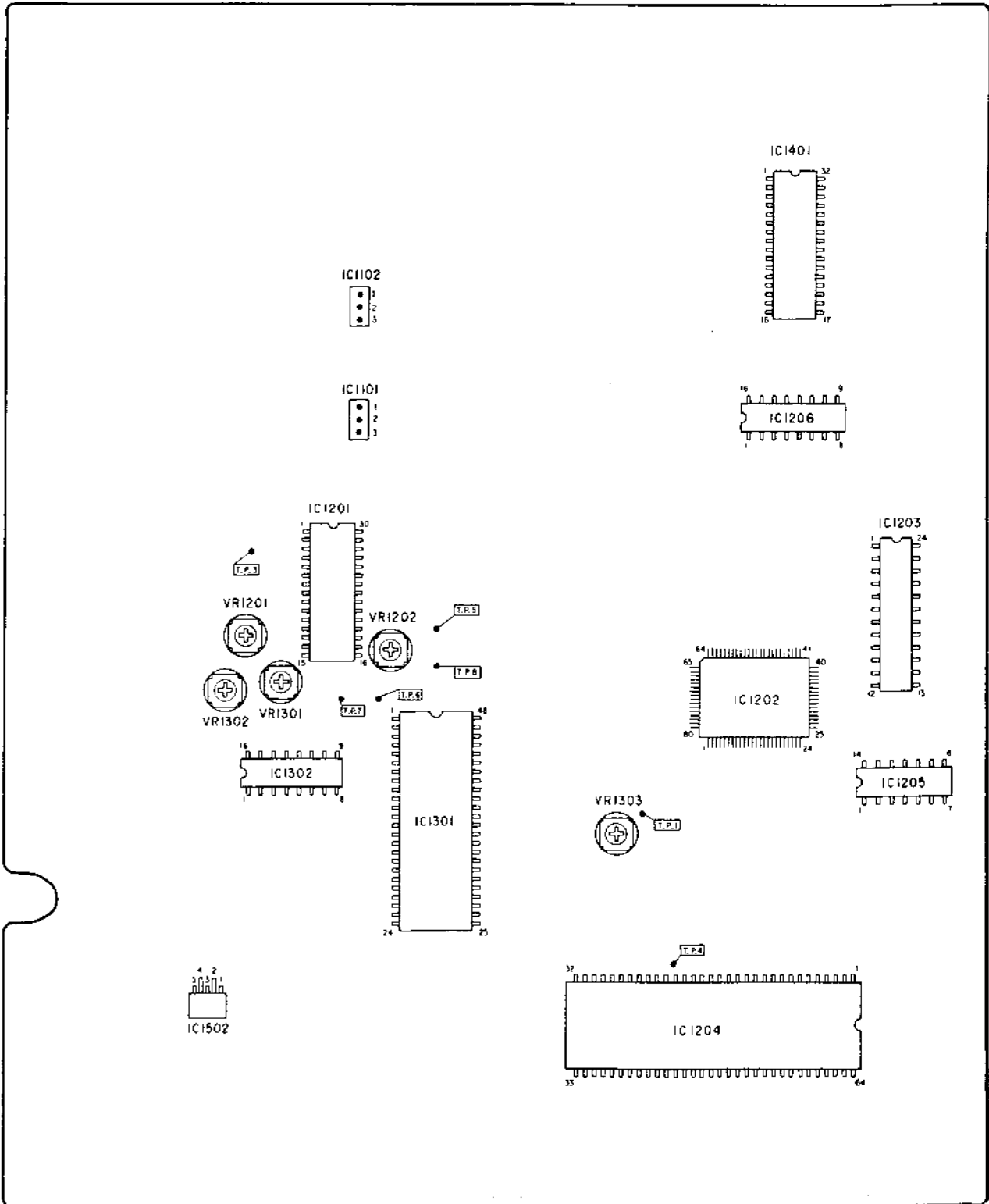

Main P. C. Board
(AD/UZ model only)

Block Diagram

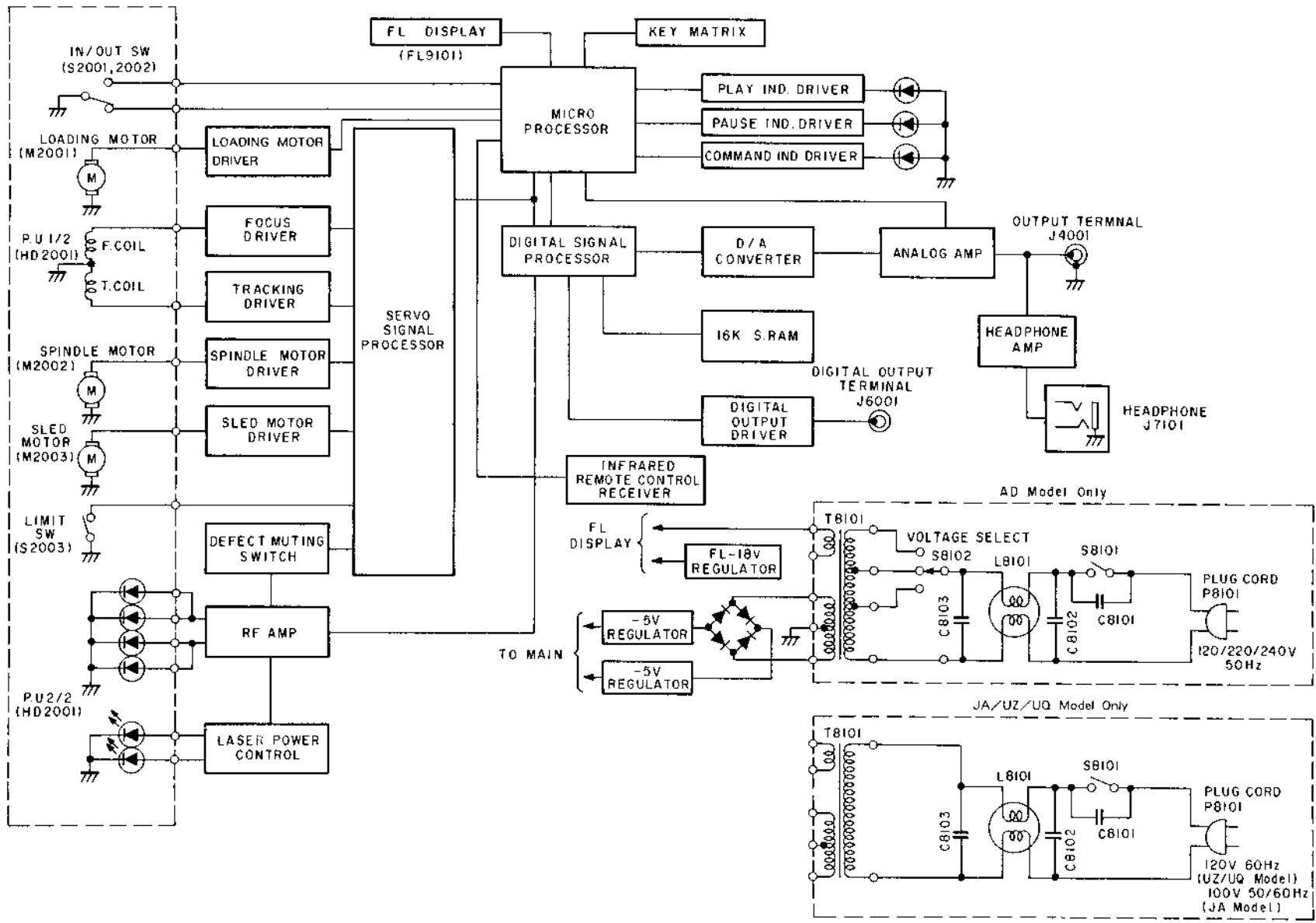

Parts Layout on P.C. Boards and Wiring Diagram ● UQ/JA model only

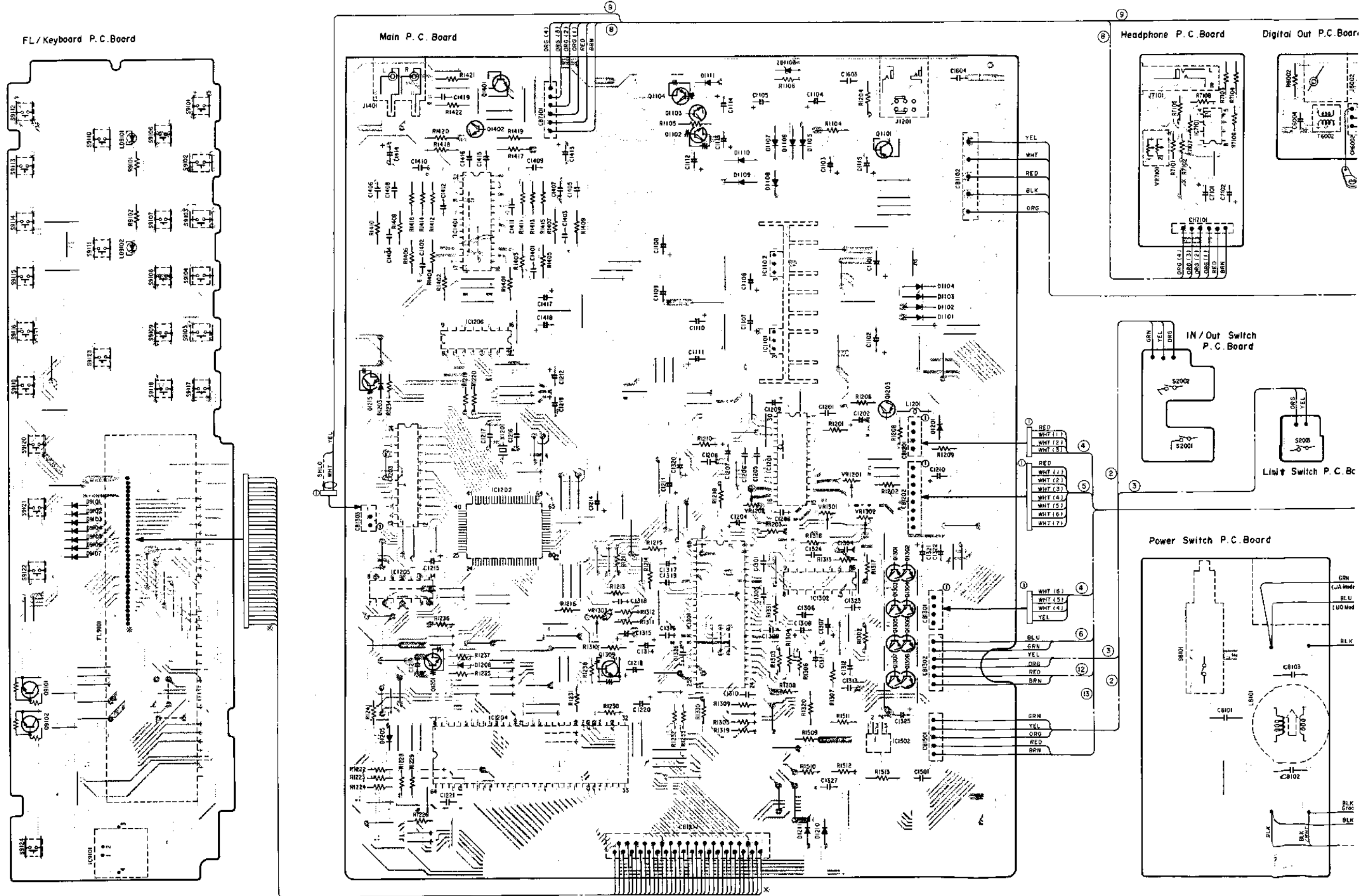

n ● UQ/JA model only

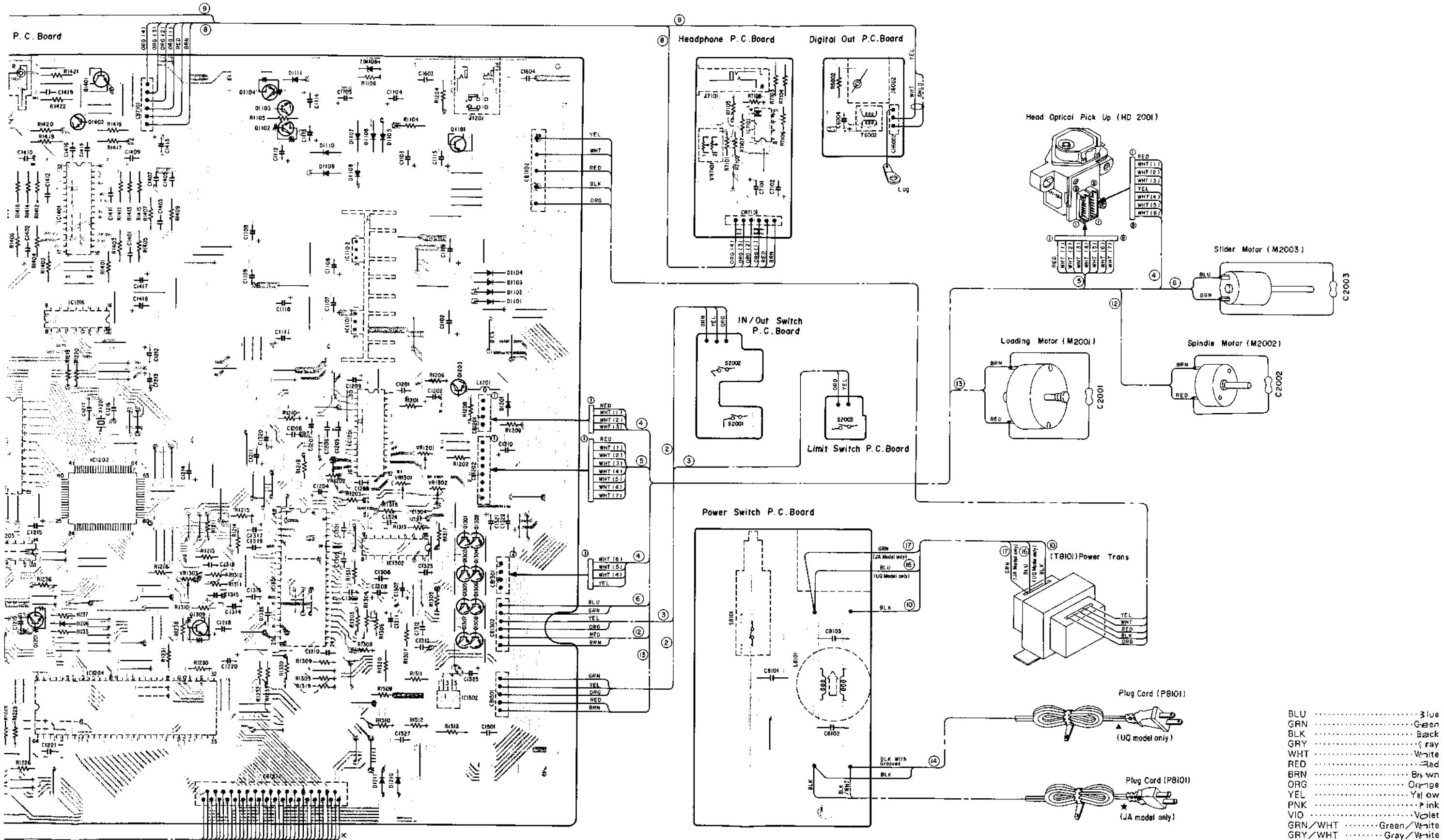

- BLU Blue
- GRN Green
- BLK Black
- GRY Gray
- WHT White
- RED Red
- BRN Brown
- ORG Orange
- YEL Yellow
- PNK Pink
- VIO Violet
- GRN/WHT Green/White
- GRY/WHT Gray/White
- GRY/YEL Gray/Yellow
- GRN/YEL Green/Yellow
- SHLD Shield

Parts Layout on P.C. Boards and Wiring Diagram ● AD/UZ model only

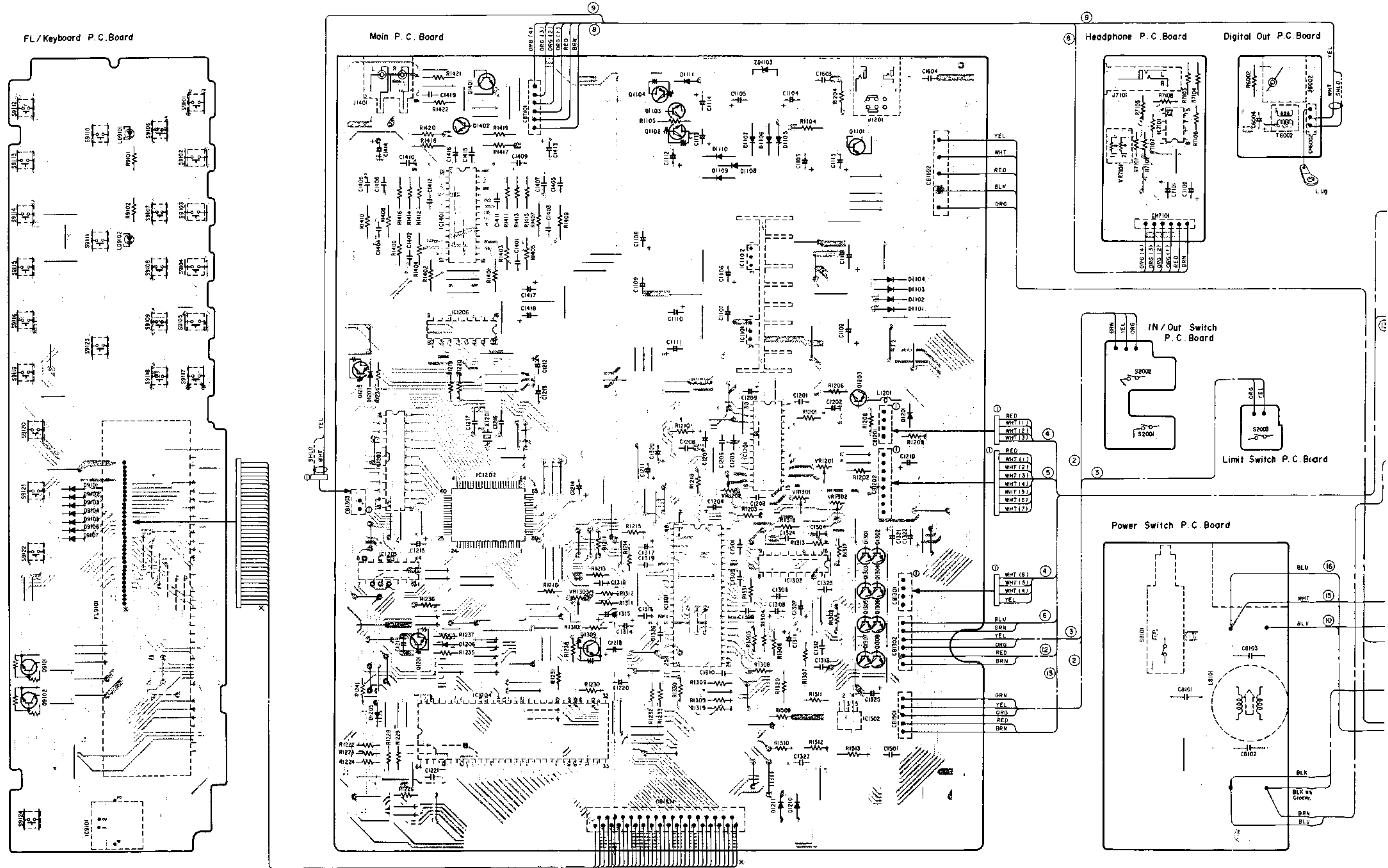

n ● AD/UZ model only

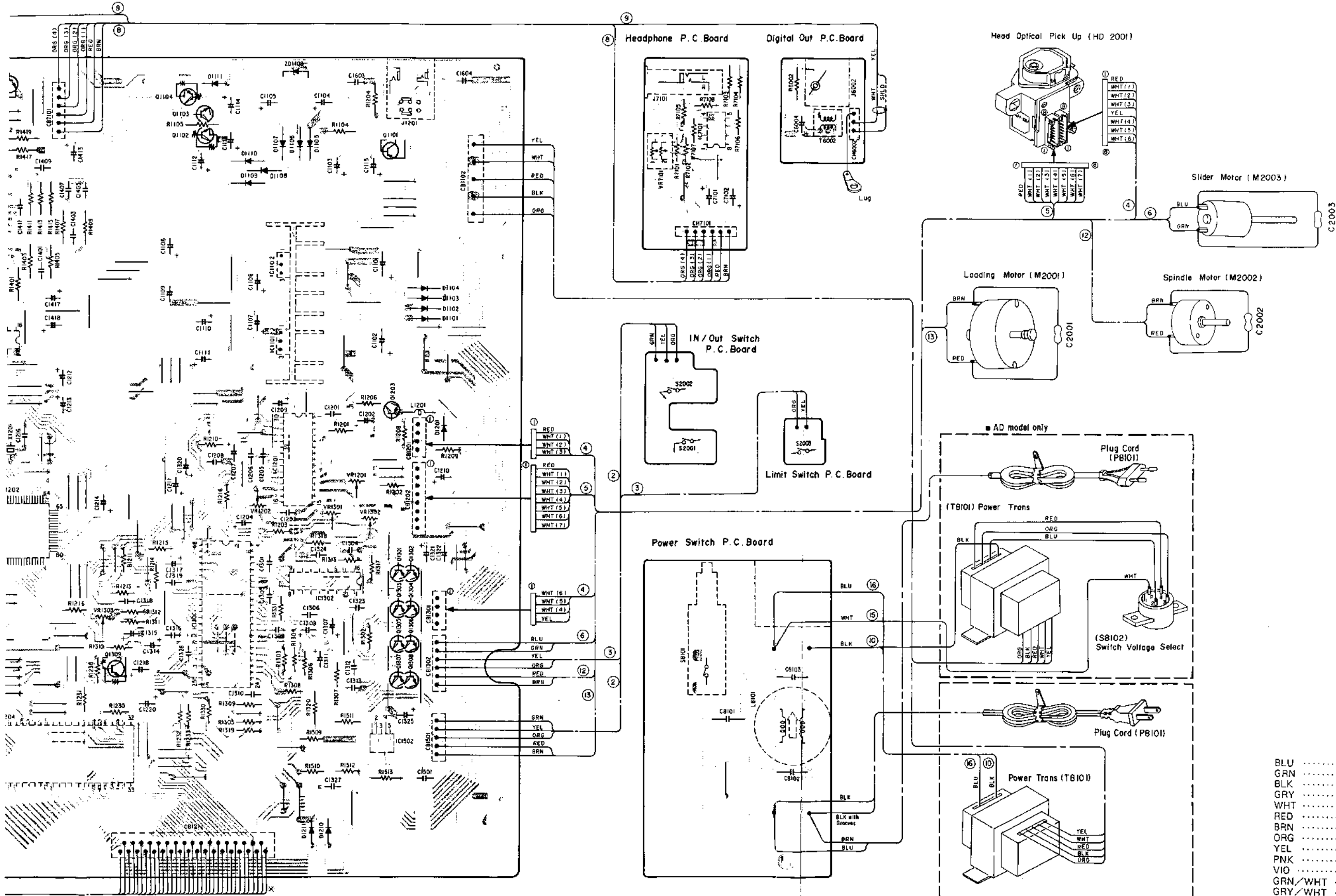

- BLU Blue
- GRN Green
- BLK Black
- GRY Gray
- WHT White
- RED Red
- BRN Brown
- ORG Orange
- YEL Yellow
- PNK Pink
- VIO Violet
- GRN/WHT Green/White
- GRY/WHT Gray/White
- GRY/YEL Gray/Yellow
- GRN/YEL Green/Yellow
- SHLD Shield

Schematic Diagram

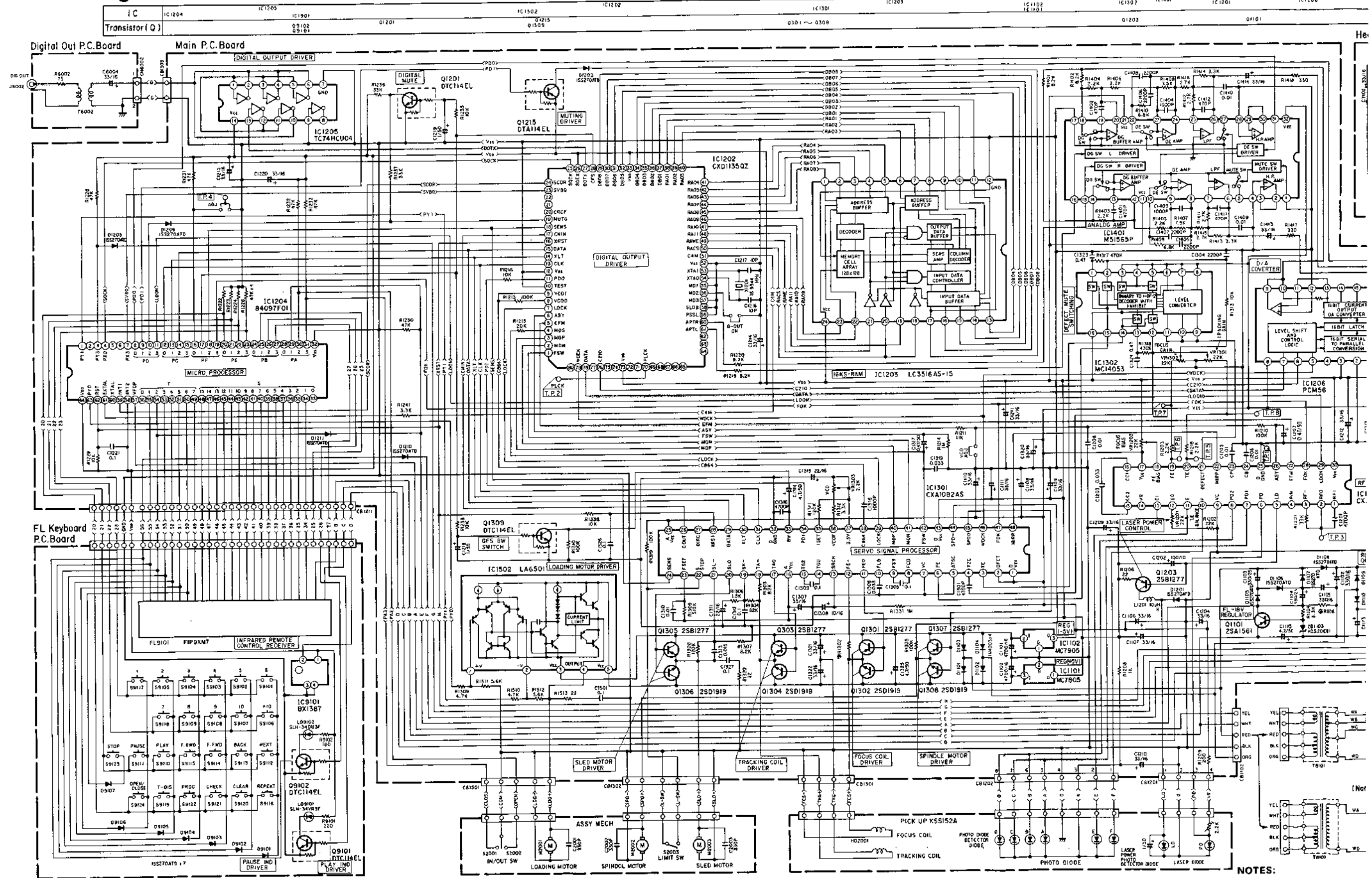

NOTES:
1. All resistance values are in ohms unless otherwise specified.

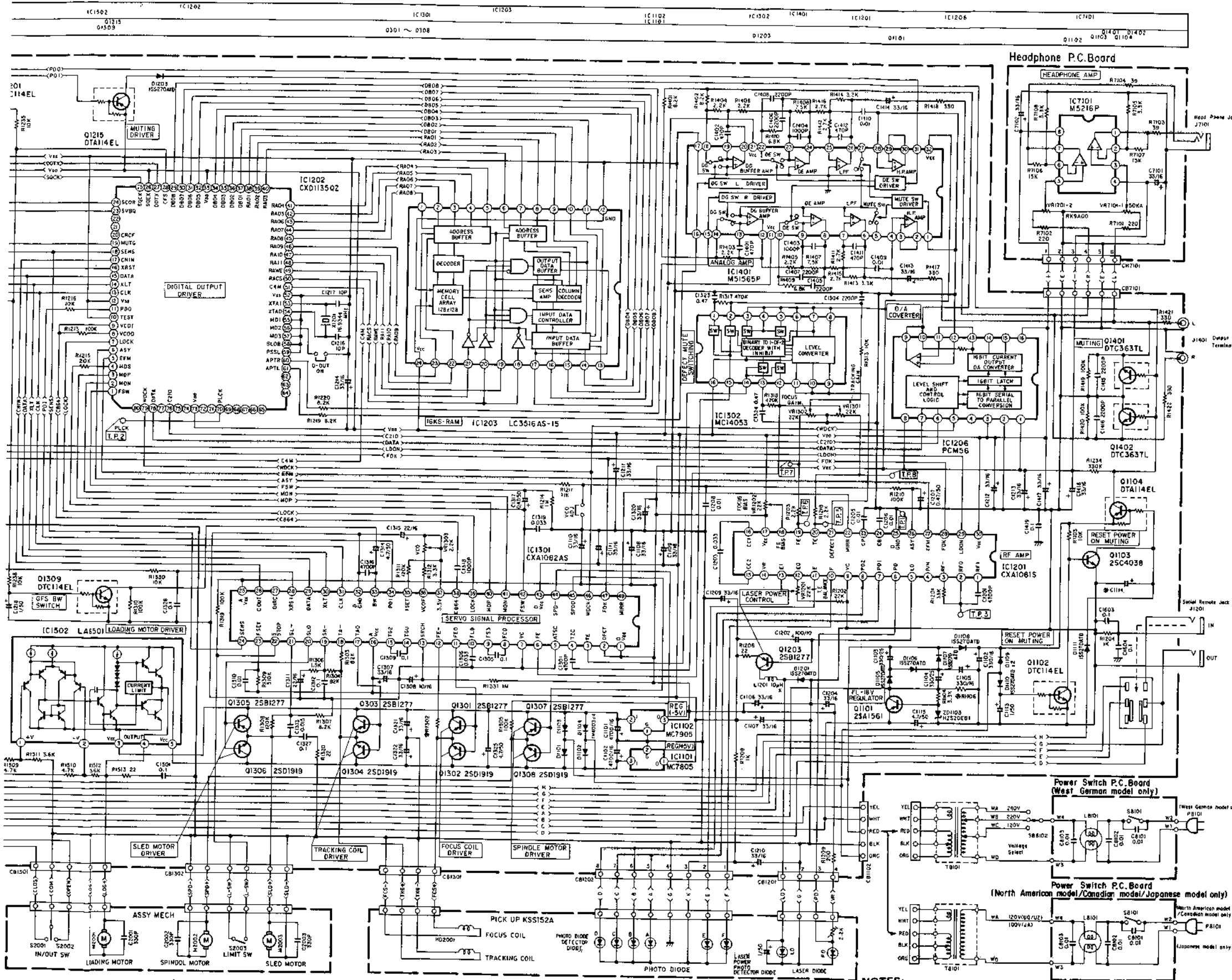

Headphone P.C. Board

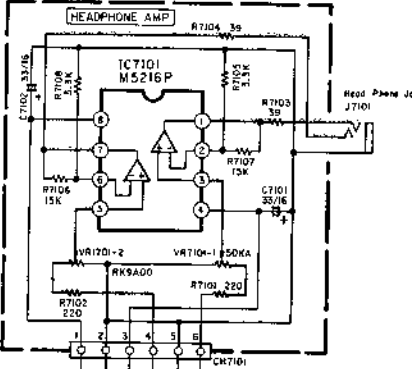

IC1201

1	0V	16	-1.9V
2	5V	17	-5V
3	0V	18	0.1V
4	3V	19	0V
5	2.2V	20	0V
6	5V	21	-5V
7	0V	22	-1.0V
8	0V	23	-1.0V
9	0V	24	-1V
10	0V	25	0V
11	0V	26	2.5V
12	0.4V	27	2.5V
13	-0.5V	28	5V
14	0V	29	0V
15	-2V	30	5V

IC1301

1	0V	11	-4.2V
2	5V	12	0V
3	0V	13	0V
4	0V	14	0V
5	0V	15	0V
6	0V	16	0V
7	0V	17	0V
8	0V	18	0V
9	0V	19	0V
10	0V	20	0V
11	0V	21	0V
12	0V	22	0V
13	0V	23	0V
14	0V	24	0V
15	0V	25	0V
16	0V	26	0V
17	0V	27	0V
18	0V	28	0V
19	0V	29	0V
20	0V	30	0V

IC1202

1	0V	21	0.15V	41	2.5V	R1	L.3V
2	0V	22	0.15V	42	2.5V	R2	0V
3	0V	23	0V	43	2.5V	R3	0V
4	0V	24	0V	44	2.5V	R4	0.2V
5	0V	25	0V	45	2.5V	R5	0V
6	5V	26	0.1V	46	2.5V	R6	0V
7	5V	27	0.1V	47	2.5V	R7	0V
8	2.5V	28	0.1V	48	0V	R8	0V
9	0V	29	0.1V	49	0V	R9	2.5V
10	0V	30	0.1V	50	2.5V	R10	2.5V
11	0V	31	0V	51	0V	R11	0V
12	0V	32	0V	52	0V	R12	0V
13	0V	33	0V	53	2.5V	R13	5V
14	0V	34	0V	54	2V	R14	0V
15	0V	35	0V	55	0V	R15	2.5V
16	0.14V	36	0.1V	56	0V	R16	2.5V
17	0.15V	37	0V	57	0V	R17	2.5V
18	0.16V	38	0.1V	58	0V	R18	0V
19	0.15V	39	0.1V	59	0V	R19	0V
20	0.16V	40	2.5V	60	J.3V	R20	2.5V

IC1302

1	0V	8	-5V
2	0V	9	0V
3	-5V	10	0V
4	-5V	11	0V
5	-5V	12	0V
6	-5V	13	0V
7	-5V	14	0V
8	-5V	15	0V
9	-5V	16	5V

IC1401

1	0V	17	0V
2	0V	18	0V
3	0V	19	0V
4	0V	20	0V
5	0V	21	5V
6	0V	22	0V
7	0V	23	0V
8	0.01V	24	0V
9	0V	25	0V
10	0V	26	0.02V
11	0V	27	0V
12	0V	28	0V
13	0V	29	0V
14	0V	30	0V
15	0V	31	0V
16	0.25V	32	-5V

IC1502

1	0V
2	0V
3	-11V
4	0V
5	10.2V

IC1204

1	0V	23	0V	43	20V
2	0V	24	0V	44	20V
3	5V	25	0V	45	30V
4	5V	26	0V	46	21V
5	0V	27	5V	47	24V
6	0V	28	0V	48	20V
7	1.5V	29	0.4V	49	27V
8	0V	30	0V	50	27V
9	5V	31	0V	51	27V
10	0V	32	0V	52	27V
11	0V	33	2.5V	53	27V
12	5V	34	15V	54	27V
13	5V	35	0.8V	55	20V
14	4V	36	12.4V	56	5V
15	5V	37	26.4V	57	0V
16	5V	38	3V	58	3.3V
17	5V	39	10V	59	2.5V
18	4V	40	15V	60	5V
19	5V	41	5V	61	5V
20	0V	42	25.0V	62	5V
21	0V	43	5V	63	5V
22	0V	44	10V	64	5V

IC1205

1	2.4V	8	5V
2	2.5V	9	0V
3	2.48V	10	2.53V
4	2.55V	11	2.49V
5	2.49V	12	2.49V
6	2.5V	13	2.52V
7	0V	14	5V

IC1206

1	-5V	8	0V
2	0V	9	0V
3	5V	10	0V
4	0V	11	0V
5	2.48V	12	2.49V
6	2.5V	13	2.52V
7	0V	14	5V

NOTES:
 1. All resistance values are in ohms. K = 1,000 2. All capacitance values are in microfarads. P = $\frac{1}{1,000,000}$

- [Measuring Conditions]**
 1. Power Supply Voltage:
 :120/220/240V 50Hz(AD model only)
 :AC120V 60Hz(UZ/UQ model only)
 :100V 50/60Hz(JA model only)
 2. Measuring Meter:
 :Null Voltmeter
 3. Measuring Point Reference:
 :Between Ground
 4. Measuring Condition:
 :No Signal Input
 :CD Inlay Condition

Electrical Parts List

Resistor : Carbon resistors under 1/4 watts are not mentioned in the parts list, please confirm them by schematic diagram.
 uF = microfarads, pF = picofarads

Abbreviations					Symbol No.	Part No.	Description							
RES. = Resistor C.F. = Carbon Film M.F. = Metal Film M.O. = Metal Oxide Film M.P. = Metal Plate TR. = Transistor TRANS. = Transformer CP. = Chip CAP. = Capacitor ELY. = Electrolytic CER. = Ceramic MYL. = Mylar TAN. = Tantalum POLY. = Polystyrol PP. = Polypropylene PLT. = Polyethylene														
Main P. C. Board					Diodes									
IC's					D1101	48S40477U01	IN4003							
IC1101	51T94884F01	MC7805			D1102	48S40477U01	IN4003							
IC1102	51T94885F01	MC7905			D1103	48S40477U01	IN4003							
IC1201	51T84721F01	CXA1081S			D1104	48S40477U01	IN4003							
IC1202	51T84719F01	CXD1135QZ			D1105	48T84758F01	1SS270ATD							
IC1203	51T84723F01	LC3516AS			or	48T58583F01	1SS176							
IC1204	51T84097F01	84097F01			D1106	48T84758F01	1SS270ATD							
IC1205	51T94890F01	MC74HCU04			or	48T58583F01	1SS176							
IC1206	51T80318F02	PCM56P			D1107	48T84758F01	1SS270ATD							
IC1301	51T84722F01	CXA1082AS			or	48T58583F01	1SS176							
IC1302	51T94886F01	MC14053			D1108	48T84758F01	1SS270ATD							
IC1401	51T84334F01	M51565P			or	48T58583F01	1SS176							
IC1502	51T90889F01	LA6501			D1109	48T84758F01	1SS270ATD							
Transistors					or	48T58583F01	1SS176							
Q1101	48T82757F01	2SA1561			D1110	48T84758F01	1SS270ATD							
Q1102	48T82763F02	DTC114EL			or	48T58583F01	1SS176							
Q1103	48T82758F01	2SC4038			D1111	48T84758F01	1SS270ATD							
Q1104	48T82762F02	DTA114EL			or	48T58583F01	1SS176							
Q1201	48T82763F02	DTC114EL			D1201	48T84758F01	1SS270ATD							
Q1203	48T82759F01	2SB1277			or	48T58583F01	1SS176							
Q1215	48T82762F02	DTA114EL			D1203	48T84758F01	1SS270ATD							
Q1301	48T82759F01	2SB1277			or	48T58583F01	1SS176							
Q1302	48T83275F01	2SD1919			D1205	48T84758F01	1SS270ATD							
Q1303	48T82759F01	2SB1277			or	48T58583F01	1SS176							
Q1304	48T83275F01	2SD1919			D1206	48T84758F01	1SS270ATD							
Q1305	48T82759F01	2SB1277			or	48T58583F01	1SS176							
Q1306	48T83275F01	2SD1919			D1210	48T84758F01	1SS270ATD							
Q1307	48T82759F01	2SB1277			or	48T58583F01	1SS176							
Q1308	48T83275F01	2SD1919			D1211	48T84758F01	1SS270ATD							
Q1309	48T82763F02	DTC114EL			or	48T58583F01	1SS176							
Q1401	48T82763F31	DTC363TL			ZD1103	48T68697F60	Zener, HZS20EB1							
Q1402	48T82763F31	DTC363TL			Coil									
					L1201	24T50508F22	Inductor, 10 uH							
					Crystal									
					X1201	48T84727F01	AT-51 16.9344M							

Symbol No.	Part No.	Description			Symbol No.	Part No.	Description		
Jacks									
J1201	09T84124F01	Headphone (Serial Remote in/Dut)			■ C1308	23S40657F10	ELY., 10 μ F/16V		
J1401	09T84616F01	T5855 (Output)			★ C1308	23T00138L18	ELY., 22pF/16V		
Capacitors									
C1101	23T00135L34	ELY., 4700 μ F/16V			▲ C1308	23T00138L17	ELY., 10 μ F/16V		
C1102	23T00135L34	ELY., 4700 μ F/16V			C1309	08T57705F79	MYL., 0.1 μ F		
C1103	23S40657F65	ELY., 330 μ F/25V			C1310	08T57705F67	MYL., 0.01 μ F		
C1104	23S40657F65	ELY., 330 μ F/25V			C1311	23T00138L18	ELY., 22 μ F/16V		
C1105	23S40657F61	ELY., 330 μ F/16V			C1312	08T57705F79	MYL., 0.1 μ F		
C1106	23T00138L19	ELY., 33 μ F/16V			C1313	08T57705F69	MYL., 0.015 μ F		
C1107	23T00138L19	ELY., 33 μ F/16V			C1314	23T00138L48	ELY., 4.7 μ F/50V		
C1108	23T00138L19	ELY., 33 μ F/16V			C1315	23T00138L18	ELY., 22 μ F/16V		
C1109	23T00138L19	ELY., 33 μ F/16V			C1316	08T57705F63	MYL., 4700pF		
C1110	23T00138L19	ELY., 33 μ F/16V			C1317	23T00138L44	ELY., 0.47 μ F/50V		
C1111	23T00138L19	ELY., 33 μ F/16V			C1318	08T57705F55	MYL., 1000pF		
C1112	23S40657F61	ELY., 330 μ F/16V			C1319	08T57705F73	MYL., 0.033 μ F		
C1113	23T00138L45	ELY., 1 μ F/50V			C1320	23T00138L19	ELY., 33 μ F/16V		
● C1114	23T00138L27	ELY., 10 μ F/25V			C1321	23T00138L19	ELY., 33 μ F/16V		
■ C1114	23T00138L27	ELY., 10 μ F/25V			C1322	23T00138L19	ELY., 33 μ F/16V		
★ C1114	23T00138L17	ELY., 10 μ F/16V			● C1323	08T42629F37	MYL., 0.47 μ F		
▲ C1114	23T00138L17	ELY., 10 μ F/16V			■ C1323	08T42629F37	MYL., 0.47 μ F		
C1115	23T00138L48	ELY., 4.7 μ F/50V			★ C1323	08T57851F21	TF., 0.47 μ F		
C1201	08T57705F63	MYL., 4700pF			▲ C1323	08T57851F21	TF., 0.47 μ F		
C1202	23T00138L12	ELY., 100 μ F/10V			● C1324	08T42629F37	MYL., 0.47 μ F		
C1203	08T57705F73	MYL., 0.033 μ F			■ C1324	08T42629F37	MYL., 0.47 μ F		
C1204	23T00138L19	ELY., 33 μ F/16V			★ C1324	08T57851F21	TF., 0.47 μ F		
C1205	08T57705F67	MYL., 0.01 μ F			▲ C1324	08T57851F21	TF., 0.47 μ F		
C1206	08T57705F67	MYL., 0.01 μ F			C1325	23T00138L48	ELY., 4.7 μ F/50V		
C1207	23T00138L44	ELY., 0.47 μ F/50V			C1326	08T40794F74	CER., 0.1 μ F		
C1208	08T57705F67	MYL., 0.01 μ F			C1327	08T57705F79	MYL., 0.1 μ F		
C1209	23T00138L19	ELY., 33 μ F/16V			C1401	08T57705F51	MYL., 470pF		
C1210	23T00138L19	ELY., 33 μ F/16V			C1402	08T57705F51	MYL., 470pF		
C1211	23T00138L19	ELY., 33 μ F/16V			C1403	08T57705F55	MYL., 1000pF		
C1212	23T00138L19	ELY., 33 μ F/16V			C1404	08T57705F55	MYL., 1000pF		
C1213	23T00138L19	ELY., 33 μ F/16V			C1405	08T57705F59	MYL., 2200pF		
C1214	23T00138L19	ELY., 33 μ F/16V			C1406	08T57705F59	MYL., 2200pF		
C1215	23T00138L19	ELY., 33 μ F/16V			C1407	08T57705F59	MYL., 2200pF		
C1216	08T55260F13	CER., 10pF			C1408	08T57705F59	MYL., 2200pF		
C1217	08T55260F13	CER., 10pF			C1409	08T57705F67	MYL., 0.01 μ F		
C1218	23T00138L45	ELY., 1 μ F/50V			C1410	08T57705F67	MYL., 0.01 μ F		
C1219	23T00138L45	ELY., 1 μ F/50V			C1411	08T57705F51	MYL., 470pF		
C1220	23T00138L19	ELY., 33 μ F/16V			C1412	08T57705F51	MYL., 470pF		
C1221	08T40794F74	CER., 0.1 μ F			C1413	23T00138L19	ELY., 33 μ F/16V		
C1301	08T57705F63	MYL., 4700pF			C1414	23T00138L19	ELY., 33 μ F/16V		
C1304	08T57705F59	MYL., 2200pF			C1415	08T57705F59	MYL., 2200pF		
C1305	08T57705F79	MYL., 0.1 μ F			C1416	08T57705F59	MYL., 2200pF		
C1306	08T57705F73	MYL., 0.033 μ F			C1417	23T00138L19	ELY., 33 μ F/16V		
C1307	23T00138L19	ELY., 33 μ F/16V			C1418	23T00138L19	ELY., 33 μ F/16V		
● C1308	23S40657F10	ELY., 10 μ F/16V			C1419	08T40794F74	CER., 0.1 μ F		
					C1501	08T57705F79	MYL., 0.1 μ F		
					C1603	08T40794F74	CER., 0.1 μ F		
					C1604	08T40794F74	CER., 0.1 μ F		

Notes : ● : For North American model only (UZ), ■ : For West German model only (AD),
▲ : For Canadian model only (UQ), ★ : For Japanese model only (JA), Others : Common.

Symbol No.	Part No.	Description		
Resistors				
VR1201	18C41732G08	Variable, 22k ohm B		
VR1202	18C41732G08	Variable, 22k ohm B		
VR1301	18C41732G08	Variable, 22k ohm B		
VR1302	18C41732G08	Variable, 22k ohm B		
VR1303	18C41732G18	Variable, 2.2k ohm B		
Headphone P. C. Board				
IC/Capacitors				
IC7101	51T81896F01	M5216P		
C7101	23T00138L19	ELY., 33 μ F/16V		
C7102	23T00138L19	ELY., 33 μ F/16V		
Power Switch P. C. Board				
Coil/Switch				
LB101	24T82315F01	160mH		
SB101	40T84122F01	Switch, Power Sddle (Power)		
Capacitors				
C8101	08T57437F09	CER., 0.01 μ F		
C8102	08T57437F09	CER., 0.01 μ F		
C8103	08T57437F09	CER., 0.01 μ F		
FL/Keyboard P. C. Board				
IC/Transistors				
IC9101	51T84120F01	IC, BX1387		
Q9101	48T82763F02	DTC114EL		
Q9102	48T82763F02	DTC114EL		
Diodes				
D9101	48T84758F01	1SS270ATD		
or	48T58583F01	1SS176		
D9102	48T84758F01	1SS270ATD		
or	48T58583F01	1SS176		
D9103	48T84758F01	1SS270ATD		
or	48T58583F01	1SS176		
Symbol No.	Part No.	Description		
D9104	48T84758F01	1SS270ATD		
or	48T58583F01	1SS176		
D9105	48T84758F01	1SS270ATD		
or	48T58583F01	1SS176		
D9106	48T84758F01	1SS270ATD		
or	48T58583F01	1SS176		
D9107	48T84758F01	1SS270ATD		
or	48T58583F01	1SS176		
LD9101	48T60947F05	LED, SLH-34VR3F (RED)		
LD9102	48T60947F07	LED, SLH-34DU3F (ORG)		
Switches				
S9101	40T83324F01	Tact, SKHHAP (6)		
S9102	40T83324F01	Tact, SKHHAP (5)		
S9103	40T83324F01	Tact, SKHHAP (4)		
S9104	40T83324F01	Tact, SKHHAP (3)		
S9105	40T83324F01	Tact, SKHHAP (2)		
S9106	40T83324F01	Tact, SKHHAP (+10)		
S9107	40T83324F01	Tact, SKHHAP (10)		
S9108	40T83324F01	Tact, SKHHAP (9)		
S9109	40T83324F01	Tact, SKHHAP (8)		
S9110	40T83324F01	Tact, SKHHAP (PLAY)		
S9111	40T83324F01	Tact, SKHHAP (PAUSE)		
S9112	40T83324F01	Tact, SKHHAP (NEXT)		
S9113	40T83324F01	Tact, SKHHAP (BACK)		
S9114	40T83324F01	Tact, SKHHAP (F.FWD)		
S9115	40T83324F01	Tact, SKHHAP (F.BWD)		
S9116	40T83324F01	Tact, SKHHAP (REPEAT)		
S9117	40T83324F01	Tact, SKHHAP (1)		
S9118	40T83324F01	Tact, SKHHAP (7)		
S9119	40T83324F01	Tact, SKHHAP (T-DISPLAY)		
S9120	40T83324F01	Tact, SKHHAP (CLEAR)		
S9121	40T83324F01	Tact, SKHHAP (CHECK)		
S9122	40T83324F01	Tact, SKHHAP (PROGRAM)		
S9123	40T83324F01	Tact, SKHHAP (STOP)		
S9124	40T83324F01	Tact, SKHHAP (OPEN/CLOSE)		

Symbol No.	Part No.	Description			Symbol No.	Part No.	Description		
Digital Out P. C. Board									
Trans/Capacitor									
T6002 C6004	25T94882F01 23T00138L19	Trans Puls CAP., ELY., 33 μ F/16V							
Miscellaneous									
C2001 C2002 C2003	08S40154T43 08S40154T43 08S40154T43	CAP., CER., 330pF CAP., CER., 330pF CAP., CER., 330pF							
FL9101	65T83067F01	FL, Display							
HD2001	88T96209F01	Head, Optical Pickup							
J6002	09T84775F02	Jack, Digital Output Terminal							
J7101	09T74077F01	Jack, Phone (Head Phone)							
M2001	01V11200W42	Assy., Motor Loading							
M2002	59T81431F01	Motor, Spindle							
M2003	01V94700F74	Motor, Slider							
● P8101	28T70972F01	Plug, AC Cord							
■ P8101	28T43812P04	Plug, AC Cord							
★ P8101	28T66771F01	Plug, AC Cord							
▲ P8101	28T70972F01	Plug, AC Cord							
S2001	40T71025F01	Switch, Detector (IN/OUT)							
S2002	40T71025F01	Switch, Detector (IN/OUT)							
S2003	40T71025F01	Switch, Detector (LIMIT)							
■ S8102	40T80258F02	Switch, Voltage Select							
● T8101	25T95001F01	Trans, Power							
■ T8101	25T95065F01	Trans, Power							
★ T8101	25T95257F01	Trans, Power							
▲ T8101	25T95001F01	Trans, Power							
VR7101	18T84123F01	Volume, Variable, RK9A00 (Head Phone Level)							

Notes : ● : For North American model only (UZ), ■ : For West German model only (AD),
▲ : For Canadian model only (UQ), ★ : For Japanese model only (JA), Others : Common.

Packing Assembly Parts List

Symbol No.	Part No.	Description			Symbol No.	Part No.	Description		
●	101	56S83833F42	Carton, Packing		★	106-1	68P83710F50	Owners Manual	
■	101	56S83833F42	Carton, Packing			106-2	28T70621F03	Plug, Output	
▲	101	56S83833F42	Carton, Packing			106-3	01T82091F01	Assy., Mini Plug Cord	
★	101	56S10005W06	Carton, Packing		●	106-4	01T90545F01	Unit, Remocon	
	102	56D90648F01	Tray, Packing		■	106-4	01T90545F01	Unit, Remocon RD113	
	103	56D90649F01	Tray, Packing						
	104	56B40230G23	Sack, Polyethylene		▲	106-4	01T90545F01	Unit, Remocon	
	105	56B40230G08	Sack, Polyethylene		★	106-4	01T90545F02	Unit, Remocon	
●	106-1	68P83710F06	Owners Manual			106-5	60T81756F01	Battery, UM-4MC	
■	106-1	68P93881F39	Owners Manual		★	106-6	15T15143W01	ADAPTOR, S-CD	
▲	106-1	68P93881F39	Owners Manual		★	106-7	68P96552F07	Owners, CD-ADAPTOR	

Notes : ● : For North American model only (UZ). ■ : For West German model only (AD),
▲ : For Canadian model only (UQ). ★ : For Japanese model only (JA). Others : Common.

Packing Method View

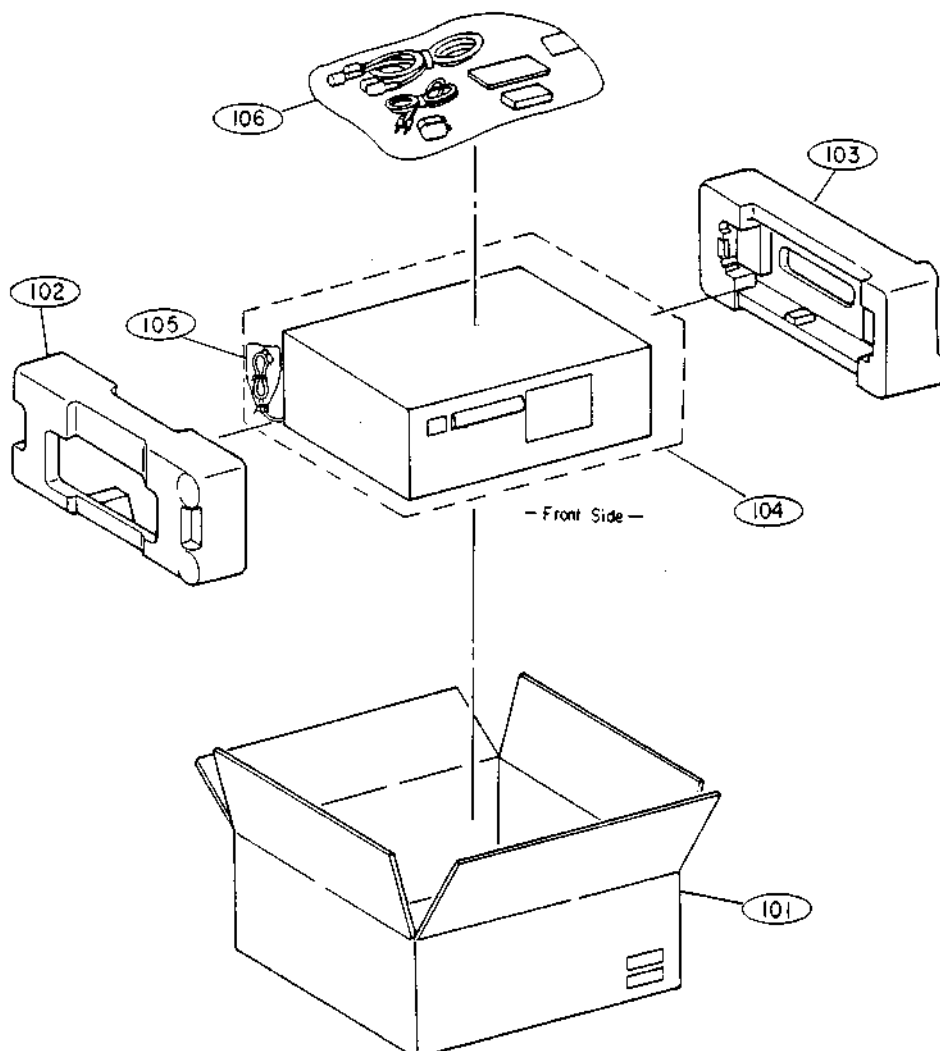

Cabinet Assembly Parts List

NOTE: The parts without part numbers are not supplied.

Symbol No.	Index	Part No.	Description	Symbol No.	Index	Part No.	Description
●	1	4-A 64D83886F08	Panel, Front	36	5-A	36A55234F04	Knob, Control
■	1	4-A 64D83886F08	Panel, Front	37	5-A	36A83870F01	Knob, Power
▲	1	4-A 64D83886F08	Panel, Front	38	5-F	07A91048F01	Support, P.C.B.
★	1	4-A 64D83886F12	Panel, Front	●	39	5-A 03S82672F18	Screw, Bind (M3 × 6)
	2	4-B 07C94897F01	Assy., Front Frame	■	39	5-A 03S82672F18	Screw, Bind (M3 × 6)
	3	2-D 15C83872F01	Cover, Top		40	03S40012G98	Screw, Tapping (M3 × 8)
	5	2-A 07D83963F02	Frame, Front		41	03S40018G08	Screw, Tapping (M3 × 8)
	6	03S71031F04	Screw, Bind (M3 × 8)		42	4-D 47A83883F01	Shaft, Power
	7	03S71031F02	Screw, Bind (M2.6 × 8)		43	4-D 43A83885F01	Spacer, Rubber
	8	3-B 36B83866F01	Knob, Eject		46	2-E 03S40018G06	Screw, Tapping (M3 × 16)
	9	3-H 16T82537F01	Cap, Pin Jack		47	2-D 03A83946F01	Screw, Special (M3 × 35)
	10	3-C 36B83864F01	Knob, Ten Key		48	04S40071G14	Washer, Spring Lock (M4.1)
	11	4-B 36A83868F01	Knob, Tact (L)		49	04S40070G59	Washer, Flat (M4.1)
	15	07A83876F01	Support, FL		50	2-A 02S40000G39	Nut, Hex (M7)
	16	3-C 14S81481F57	Insulator, Cover		51	3-B 61A92731F01	Crystal, Lens
	17	3-C 43A53357F04	Spacer, LED		52	4-G 01T94883F01	Assy., Connector
●	18	3-E 01T84733F11	Assy., Lug Wire	▲	53	03S82672F20	Screw, Bind (M3 × 8)
■	18	3-E 01T84733F11	Assy., Lug Wire	★	53	03S82672F20	Screw, Bind (M3 × 8)
	19	3-B 30T95003F01	Wire, Parallel 35P	★	54	75A96563F01	Pad, Tranning
●	21	5-D 75A67063F04	Trannleg				
■	21	5-D 75A67063F04	Trannleg				
▲	21	5-D 75A67063F04	Trannleg				
	23	3-D 43T53136F01	Bush, Cap				
●	24	5-D 75A94848F02	Pad, Felt 2T				
■	24	5-D 75A94848F02	Pad, Felt 2T				
▲	24	5-D 75A94848F02	Pad, Felt 2T				
	26	4-G 03C40121T05	Screw, W/Double Washer (M3 × 8)				
●	28	3-F 15C83873F16	Cover, Rear				
■	28	3-F 15C83873F15	Cover, Rear				
▲	28	3-F 15C83873F19	Cover, Rear				
★	28	3-F 15C83873F21	Cover, Rear				
●	29	3-E 03S44205G30	Screw, Pan (M2.6 × 4)				
■	29	3-E 03S44205G30	Screw, Pan (M2.6 × 4)				
	30	2-G 43B41625J02	Support, Cord				
	32	03S40036U01	Screw, W/Washer (M4 × 8)				
●	33	5-F 75T57059F01	Pad, Trannleg				
■	33	5-F 75T57059F01	Pad, Trannleg				
▲	33	75T57059F01	Pad, Trannleg				
	34	03S44205G52	Screw, Pan (M4 × 14)				
	35	2-C 64B83869F01	Panel, Tray				

Notes: ●: For North American model only (UZ), ■: For West German model only (AD), ▲: For Canadian model only (UQ), ★: For Japanese model only (JA), Others: Common.

Exploded View (Cabinet)

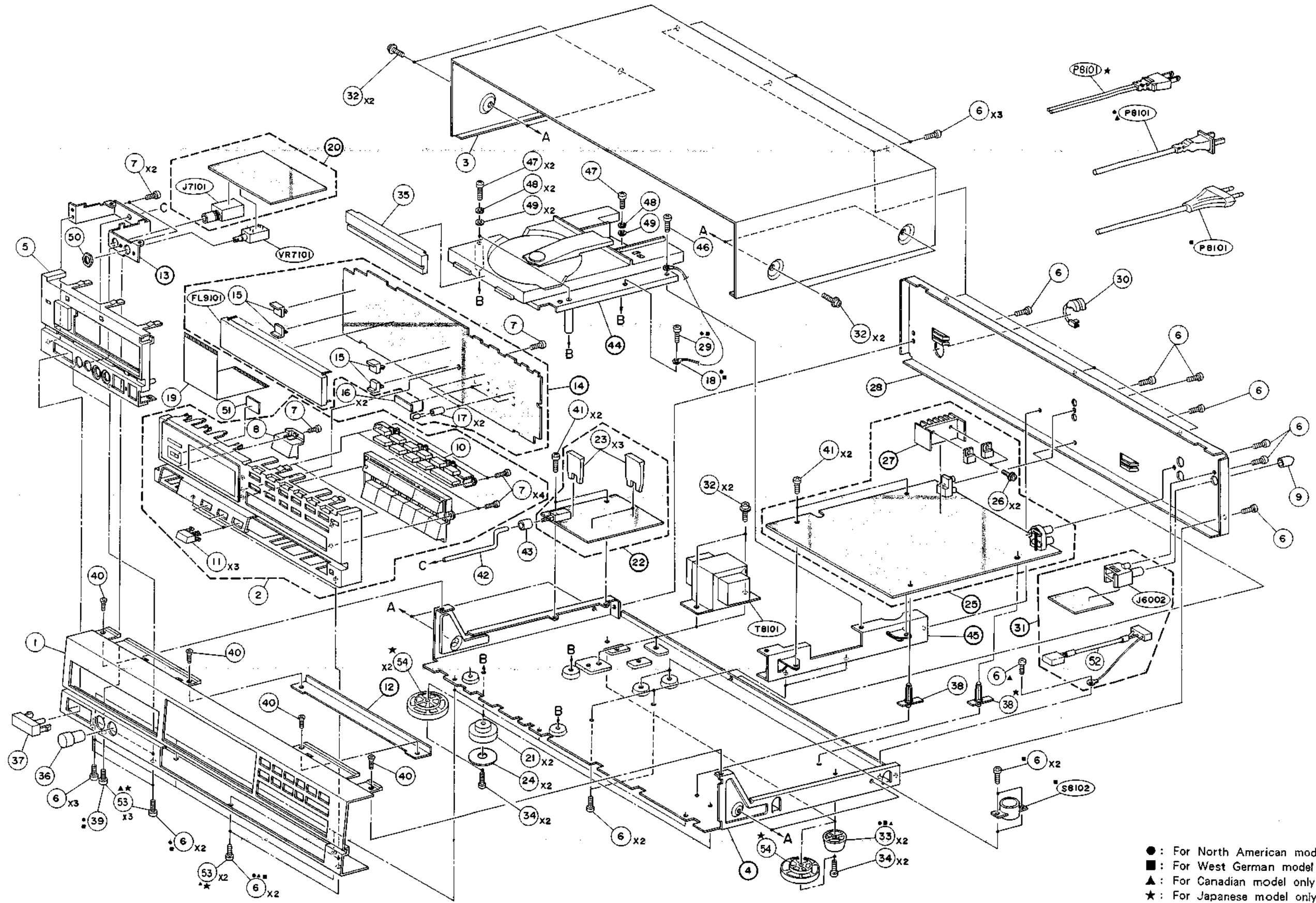

- : For North American model only (UZ)
- : For West German model only (AD)
- ▲ : For Canadian model only (UQ)
- ★ : For Japanese model only (JA)

Exploded View (CD Mechanism)

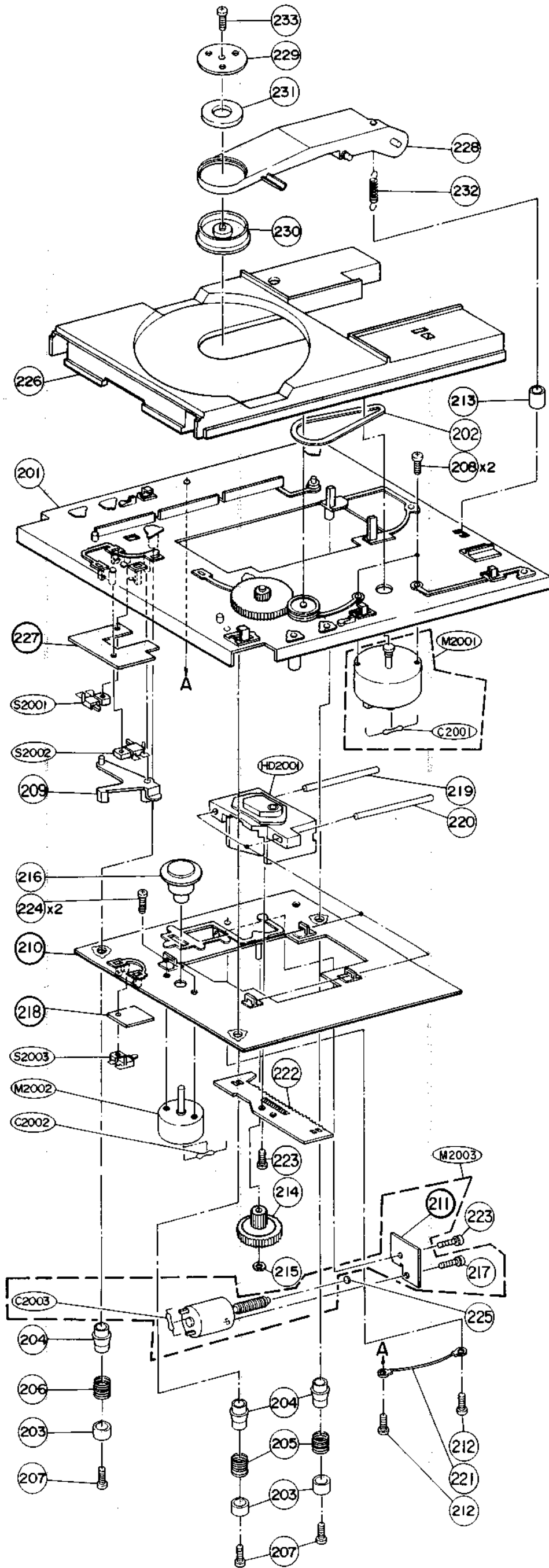

D-112

D-112

CD Mechanism Assembly Parts List

Symbol No.	Index	Part No.	Description			Symbol No.	Index	Part No.	Description		
201	5-C	01C82391F02	Assy., Main Chassis								
202	2-C	42A81427F01	Belt, Drive								
203		43A81407F01	Bush, Damper								
204		75A81411F01	Rubber, Damper								
205	3-H	41A81428F03	Spring, Compression								
206	5-H	41A81428F05	Spring, Compression								
207		03S40012G18	Screw, Tapping (M2.6 × 6)								
208	2-C	03D40014G19	Screw, W/Washer (M2.6 × 5)								
209	5-E	45A81434F01	Arm, Switch								
212	2-H	03S44205G30	Screw, Pan (M2.6 × 4)								
213	2-B	37S40133J18	Tube UL (20mm)								
214	3-G	44A81401F01	Gear, Worm Wheel								
215	3-G	04A41345P02	Washer, Lock (M1.7)								
216	5-E	49B96318F01	Table, Disc								
217	2-G	03D40014G62	Screw, W/Washer (M2 × 3)								
219	2-E	47A81426F01	Shaft, Head								
220	2-E	47A81426F02	Shaft, Head								
221	2-H	01T92483F01	Assy., Lug Wire 1P								
222	3-F	01A82323F01	Assy., Rack								
223		03C40121T31	W/Double Washer (M2 × 6)								
224	5-E	03D40014G07	Screw, W/Washer (M2 × 4)								
225	2-G	43A41182P02	Ball Steel								
226	5-B	01C81529F01	Assy., Tray Disc								
228	2-A	45C81418F02	Arm, Clamp								
229	3-A	07A81413F02	Bracket, Magnet								
230	3-B	49A81403F01	Wheel, Clamp								
231	3-A	59T81430F01	Magnet								
232	2-A	41B81429F02	Spring, Extension								
233	3-A	03S68555F17	Screw, Bind (M2 × 4)								

NOTE: The parts without part numbers are not supplied.

Semi-Conductor Lead Identifications

MC7805 : IC1101

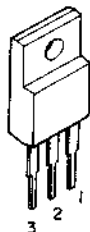

- 1. Output
- 2. GND
- 3. Input

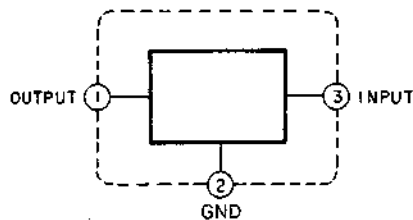

MC7905 : IC1102

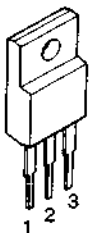

- 1. GND
- 2. Input
- 3. Output

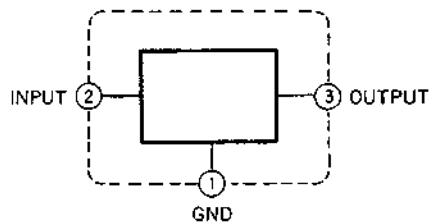

CXA1081 : IC1201

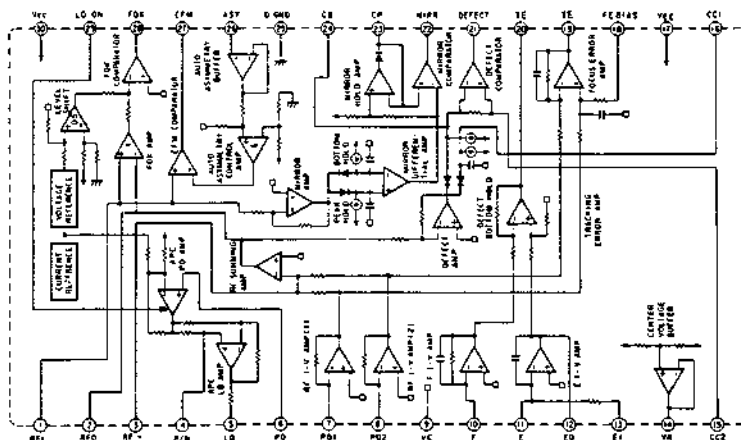
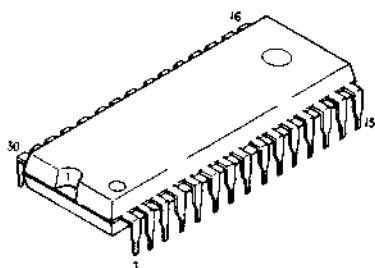

CXD1135Q : IC1202

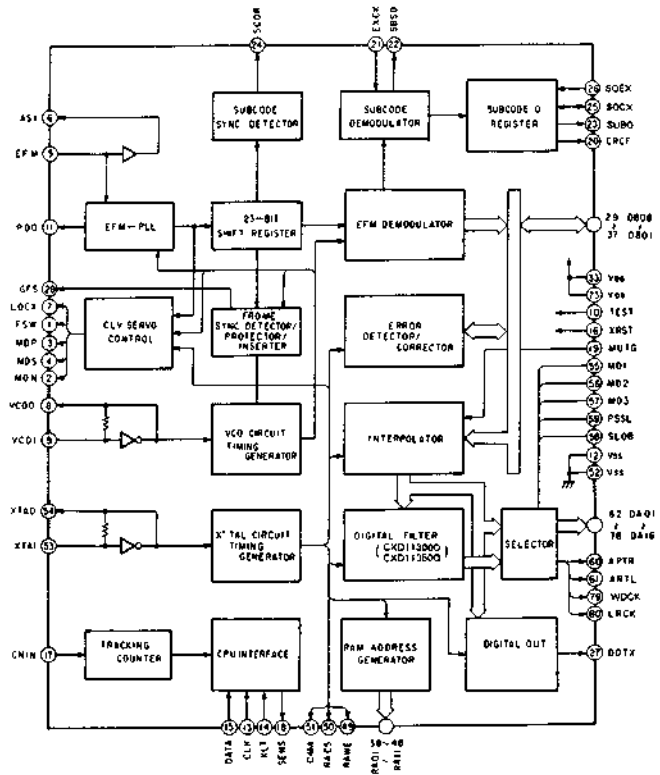
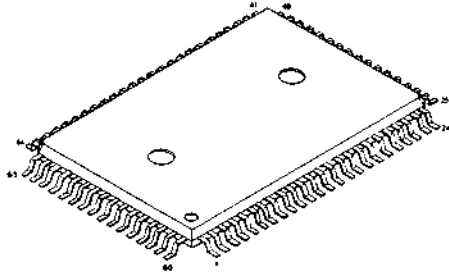

LC3516AS-15 : IC1203

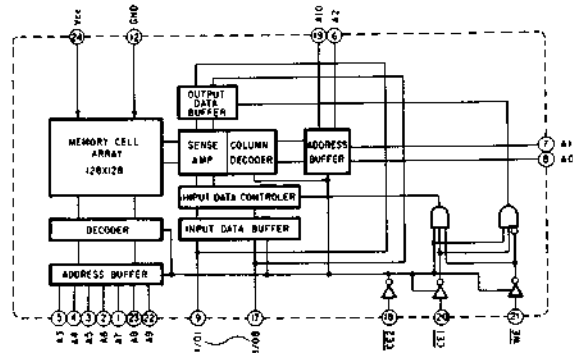
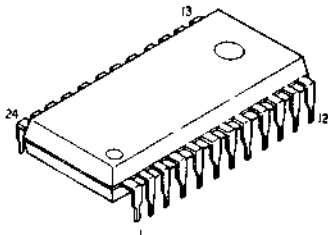

84097F01 : IC1204

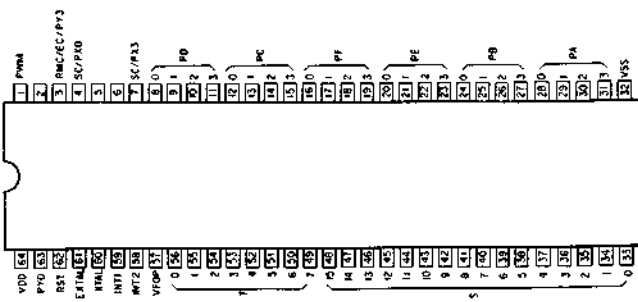
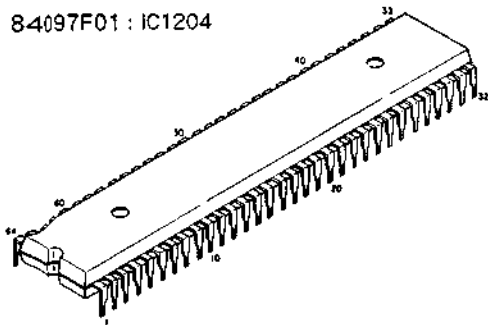

MC74HCU04 : IC1205

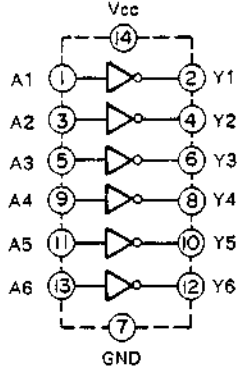
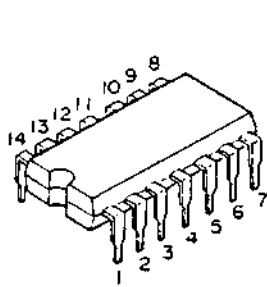

PCM56JP : IC1206

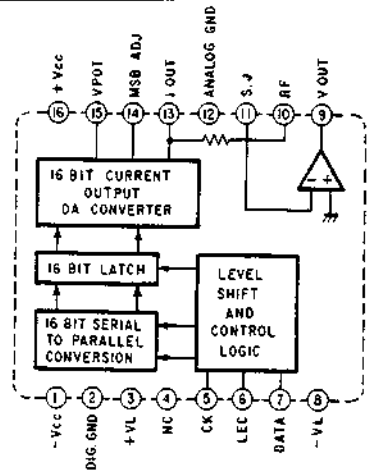
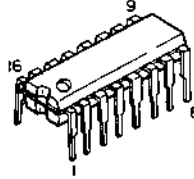

CXA1082A : IC1301

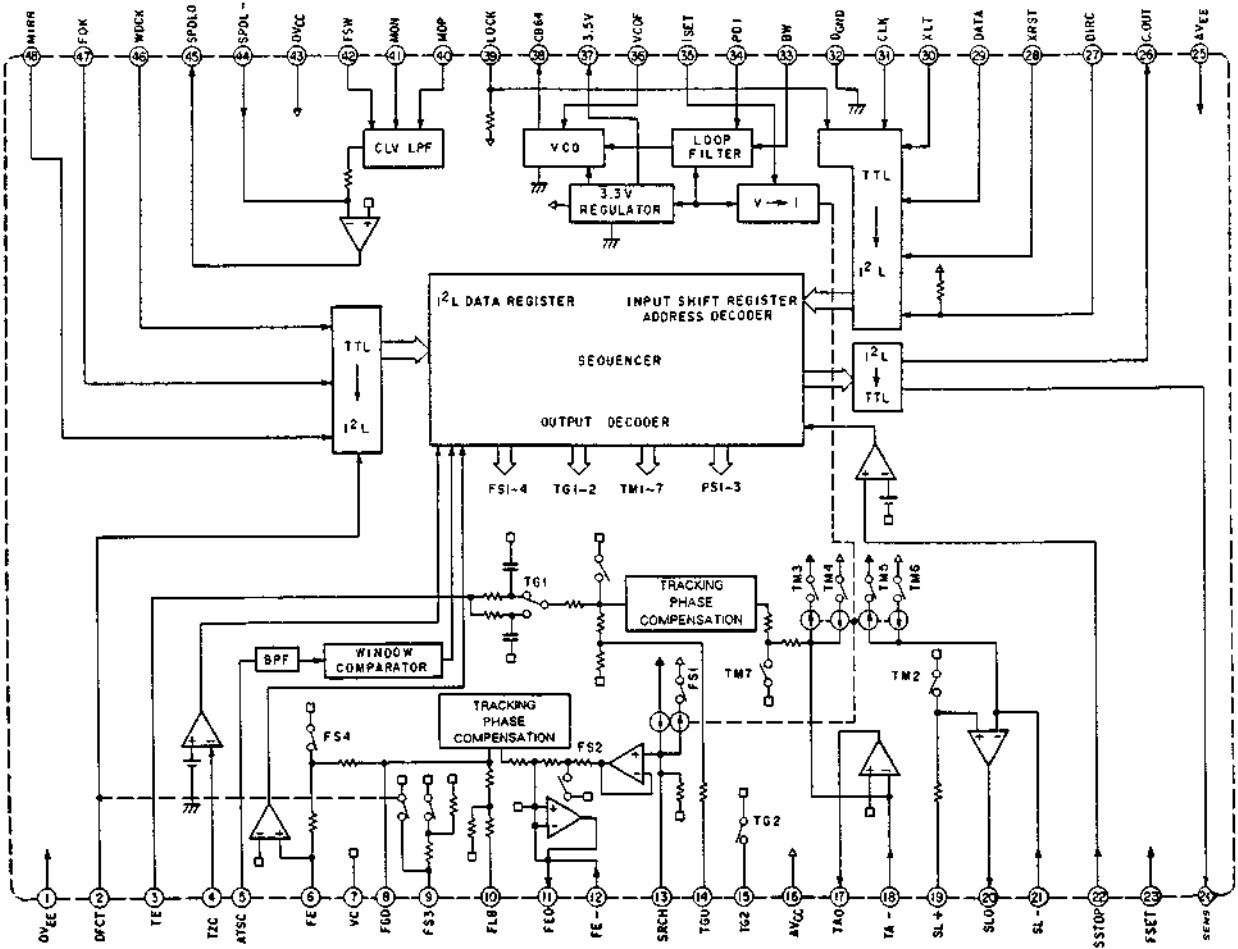
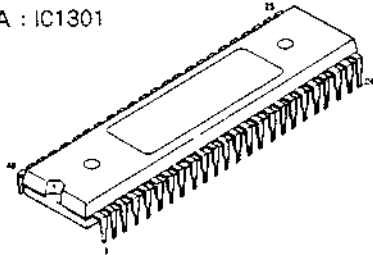

MC14053 : IC1302

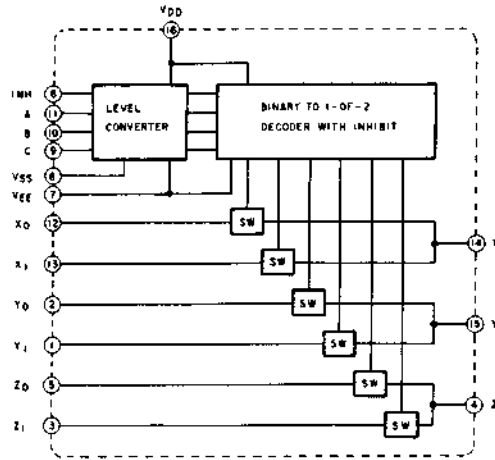
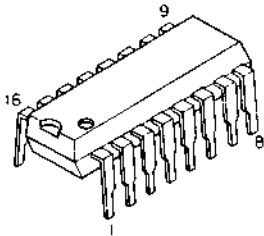

M51565P : IC1401

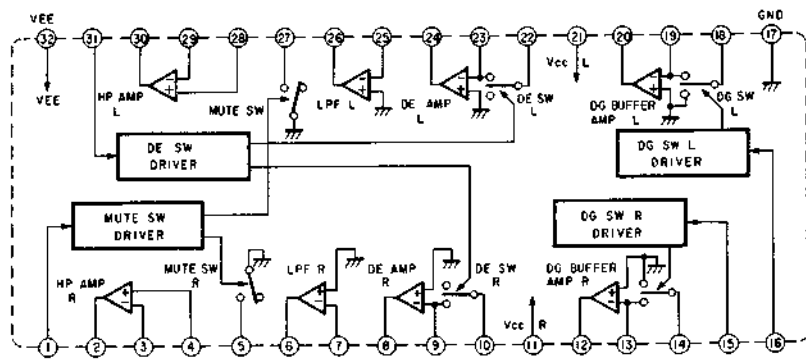
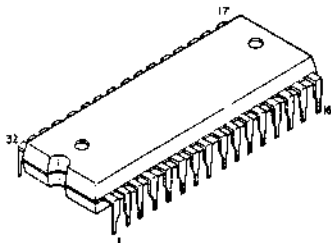

LA6501-LR : IC1502

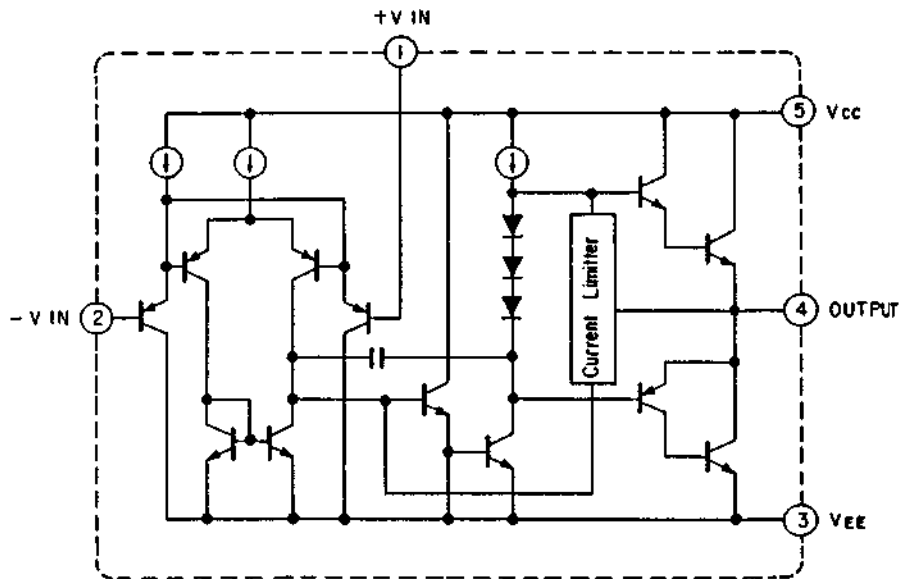
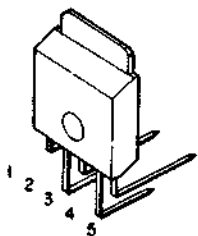

M5216P : IC7101

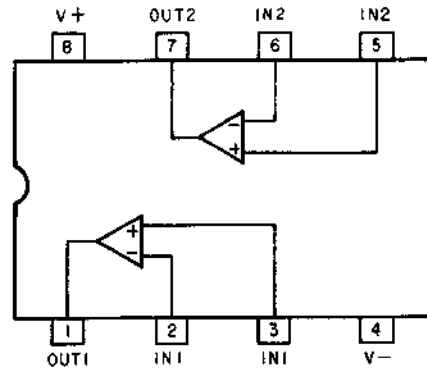
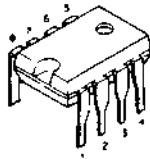

BX1387 : IC9101

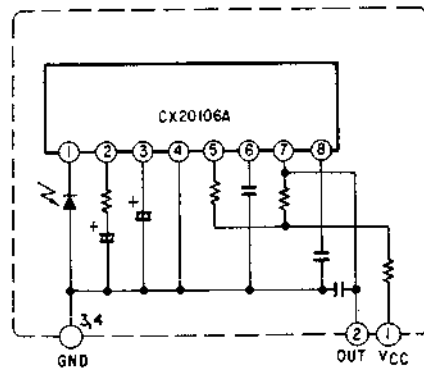
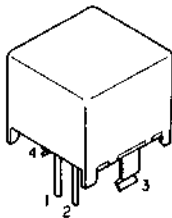

2SA1561 : Q1101

2SC4038 : Q1103

2SB1277 : Q1203, 1301, 1303, 1305, 1307

2SD1919 : Q1302, 1304, 1306, 1308

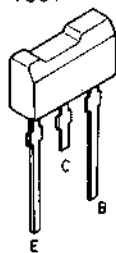

DTC114EL : Q1102, 1201, 1309, 9101, 9102

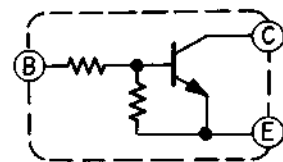
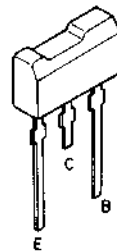

DTA114EL : Q1104, 1215

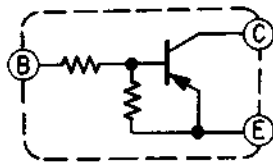
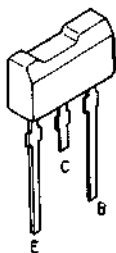

DTC363TL : Q1401, 1402

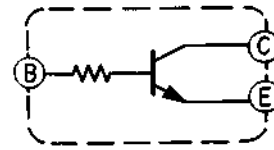
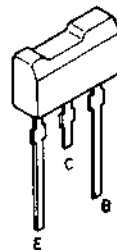



LUX CORPORATION, JAPAN

1-8, 1-Chome, Nishigotanda, Shinagawa-ku, Tokyo 141 Japan
Phone: 03-493-4381 Facsimile: 03-494-8426

5/88-S
68P10502V02
Printed in Japan