

# SERVICE MANUAL

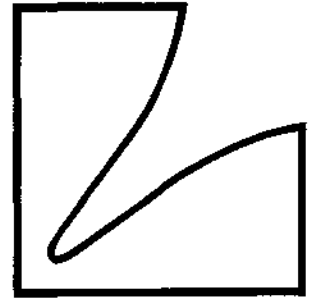

Compact Disc Player

# D-109

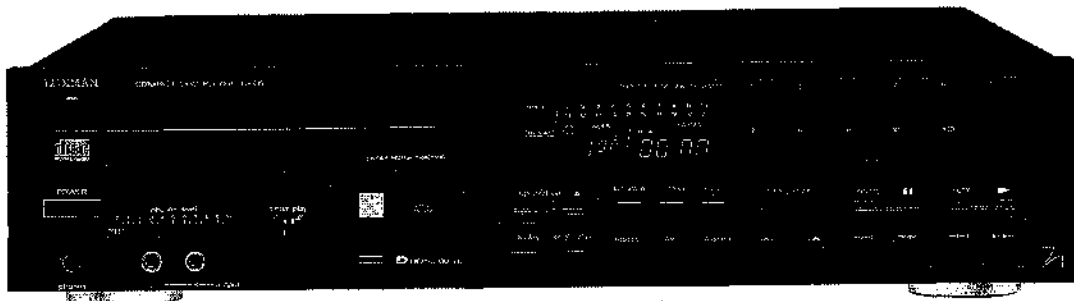

---

## Contents

---

Specifications .....	3
Service Note .....	4 to 5
Parts Locations and Disassembly Instructions .....	6 to 15
Troubleshooting Guide .....	16 to 17
Adjustment Procedures .....	18 to 21
Adjustment Locations .....	22 to 23
Block Diagram .....	24
Parts Layout on P.C. Boards and Wiring Diagram (1/2) .....	25 to 28
Parts Layout on P.C. Boards and Wiring Diagram (2/2) .....	29 to 32
Schematic Diagram (1/2) .....	33 to 35
Schematic Diagram (2/2) .....	36 to 38
Electrical Parts List .....	39 to 45
Parts List by the Destination .....	46
Packing Method View .....	47
Packing Assembly Parts List .....	47
Cabinet Assembly Parts List .....	48
Exploded View (Cabinet) .....	49 to 50
Exploded View (CD Mechanism) (1/3) .....	51 to 52
Exploded View (CD Mechanism) (2/3) .....	53 to 54
Exploded View (CD Mechanism) (3/3) .....	55 to 56
CD Mechanism Assembly Parts List .....	57 to 58
Semi-Conductor Lead Identifications .....	59 to 67

---

## Specifications

System	Optical (Compact Disc System)
Quantizing Bit Number	16-bit Linear System
Channels	2-channel, Stereo
Pickup	Semiconductor Laser Pickup
Output Voltage	2.1V±1 dB
Frequency Response	5Hz-20kHz+1, -2 dB
T. H. D (1 kHz)	0.0045%
S/N	91 dB
Dynamic Range	91 dB
Separation (1 kHz)	88 dB
Head Phone Output Voltage (1 kHz, 0 dB/8 ohm)	min 10 mW
Power Supply	AC100V, 50/60Hz (For JA Model Only) AC120V, 60Hz (For UZ and UQ Model Only) AC100/120/220/240V, 50Hz (For EK Model Only)
Power Consumption	25W
Semiconductors	35 IC's, 45 Transistors, 2 FET's 26 Diodes, 13 Zener Diodes
Dimensions	438 (W) × 387 (H) × 102 (D) mm
Weight	10.5 kg

**Note:** Due to continuing product improvement, specifications and designs are subject to change without notice.

### Note

UZ : For North American model only

UQ : For Canadian model only

EK : For General Foreign model only

JA : For Japanese model only

Others : Common

## Service Note

### Notes on Laser Diode Emission Check

The laser beam on this model is concentrated so as to be focused on the disc reflective surface by the objective lens in the optical pick-up block. Therefore, when checking the laser diode emission, observe from more than 30 cm away from the objective lens.

### Check of the Laser Diode And Focus Search Operation

With no disc loaded and the disc table closed, when switching the power on, check that the operation as shown in Figure 4 is performed, by observing the objective lens.

## サービス・ノート

### 【レーザーダイオードの発光確認時の注意】

本機のレーザー光は、光学系ブロック内の対物レンズによってディスクの反射面上に焦点を結ぶように集光されています。したがって、レーザーダイオードの発光を確認するときは、対物レンズより30cm以上目を離して下さい。

### 【レーザーダイオードおよびフォーカスサーチ動作のチェック方法】

- ・ディスクを入れないで、ディスクテーブルが閉じた状態から、POWERスイッチONさせた時、対物レンズを見て右図の動作が行なわれるか確認する。

### ● Caution For Electrostatic Breakdown Notes on Handling The Base Unit (BU-1C)

The laser diode in the optical pick-up block may suffer electrostatic breakdown because of the potential difference generated by the charged electrostatic load, etc. on clothing and the human body.

The printed matter below is included in the repair parts. During repair, use the procedure in the printed matter.

The following method is an example for reference purposes :

1. Place a conductive sheet on the workbench. (The black sheet used as repair parts wrapping.)
2. Place the set on the conductive sheet so that the chassis touches the sheet. (This makes it the same potential as the conductive sheet.)
3. Place your hands on the conductive sheet. (This makes them the same potential as the sheet.)
4. Remove the optical pick-up block from the bag (conductive).
5. Perform work on top of the conductive sheet. Be careful that clothing does not touch the optical pick-up block.

Settle the optical pick-up block and the chucking arm by pressing with the fingers.

光学ブロックとチャッキングアームを指で押さえておく。

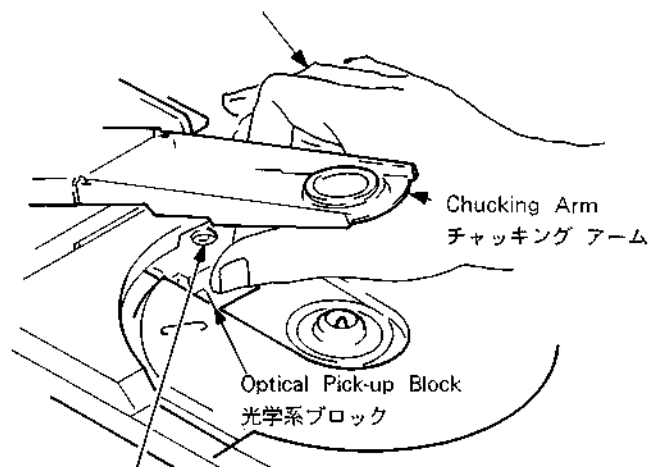

- ① Laser beam emits spreadingly.
- ② The objective lens operates up-and-down three times.
- ① レーザー光の拡散した光が見える。
- ② 対レンズの上下運動 (3回)。

### ● 静電破壊についての注意

#### BU-1C (ベースユニット) 取扱時の注意

光学系ブロック内のレーザーダイオードは、衣服や人体に帯電した静電荷等で電位差を生じることにより、静電破壊することがあります。静電破壊に対する注意として、下記の文章の印刷物が補修用の部品に同封されております。

修理時においては、静電破壊に対して十分に注意し、印刷物の効果と同等の作業方法で行なって下さい。

なお、参考例として次の方法があります。

1. 導電性のシート (補修用の部品の包装に使われている黒色のシート) を作業台に敷く。
2. セットを導電性のシートの上にシャーシ部が触れるように乗せる。(導電性のシートと同電位にするためです。)
3. 導電性のシートの上に手を乗せる。(導電性のシートと同電位にするためです。)
4. 光学系ブロックを取り出す。
5. 導電性のシートの上で作業を行なう。このとき、衣服が光学系ブロックに触れないように注意して下さい。

# Parts Locations and Disassembly Instructions

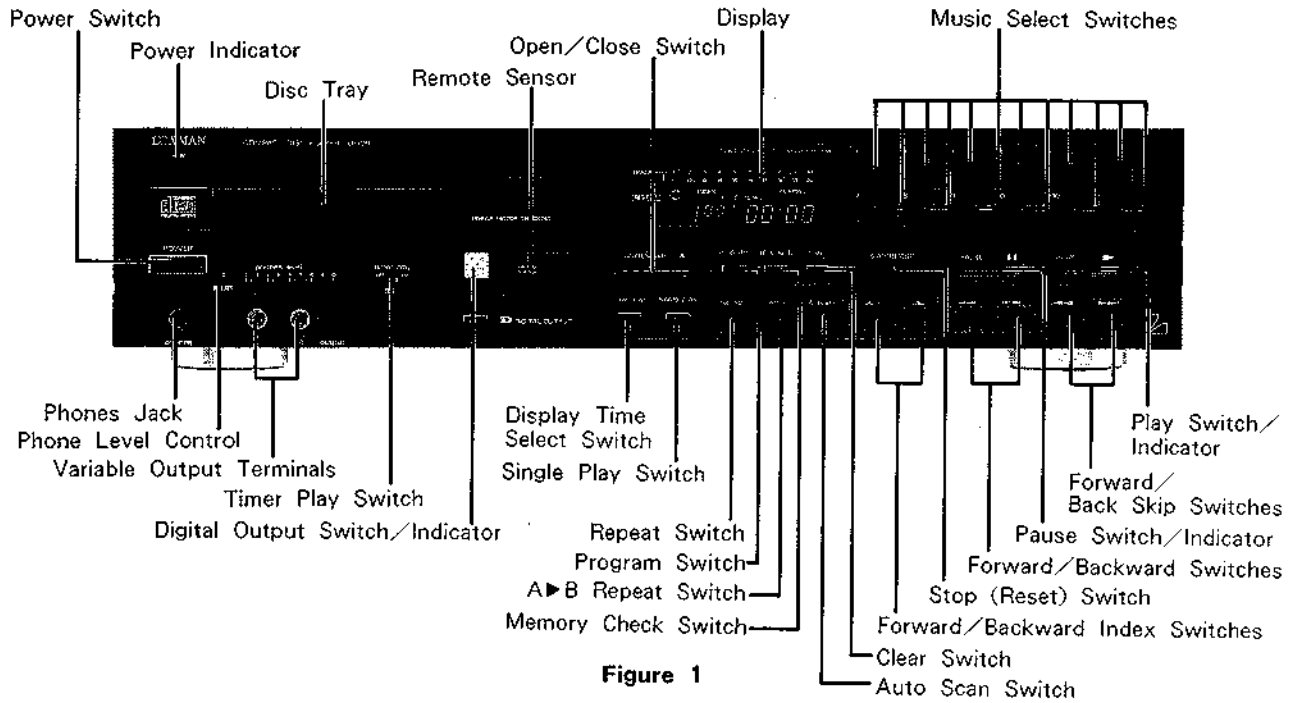

Figure 1

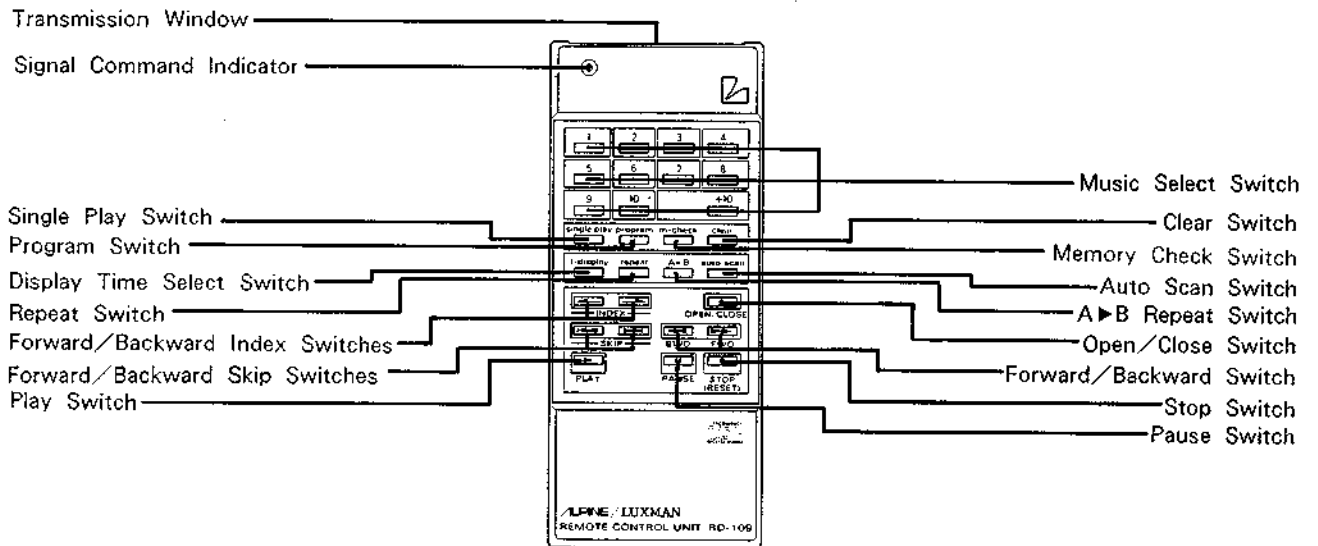

Figure 2

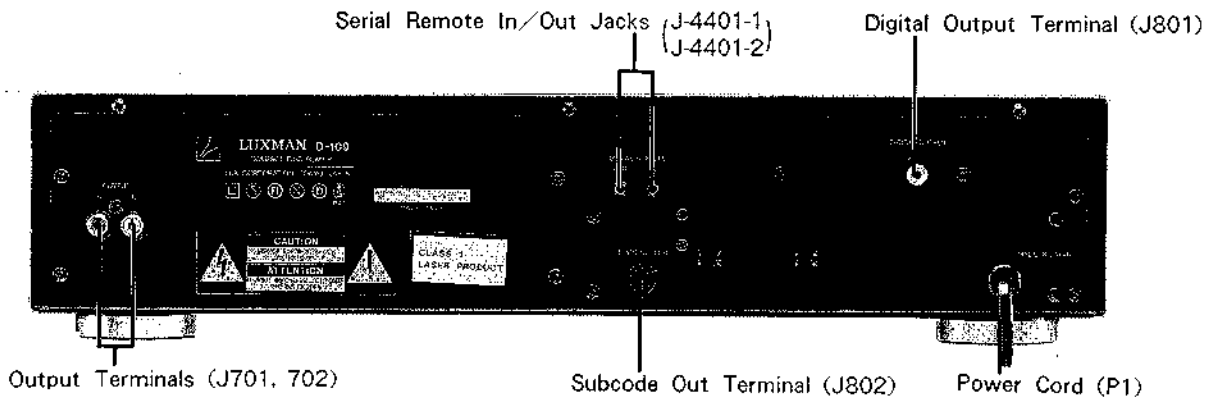

Figure 3

● Printed Matter Included in the Repair Parts

When opening or repairing BU-1C, procedures for grounding as follows is required to prevent damage caused by static electricity.

1. Grounding for the human body.

Be sure to put on a wrist-strap for grounding (with impedance lower than  $10^6 \Omega$ ) whose other end is grounded. The strap works to drain away the static electricity build-up on the human body.

2. Grounding for the work table.

Be sure to lay on the table a conductive sheet (with impedance lower than  $10^6 \Omega$ ) such as a sheet of copper, which is grounded.

3. As static electricity build-up on clothes is not drained away, be careful not to let your clothes touch the BU-1C.

**Packing Method of the unit removed.** When returning the removed unit, use the packing kits supplied and pack them in the black carton as it was.

● 補修用部品に同封されている印刷物

BU-1Cの開梱および修理のときには、静電気破壊防止のための下記のアース処理が必要です。

①人体アース

人体に帯電する静電気を逃がすため、グラウンドアースをとったアースバンド ( $10^6 \Omega$ 以下) を必ず着用してください。

②作業台のアース

BU-1Cの置き場所には、必ず導電性のシート ( $10^6 \Omega$ 以下) か銅板をひき、グラウンドアースをとってください。

③衣服に帯電した静電気は、アースバンドからは逃げませんので、衣服がBU-1Cに触れぬように注意してください。

返品の際の包装の仕方

返品部品は梱包されていた包装材を用い、またもともとおり黒いケースに入れてお返し下さい。

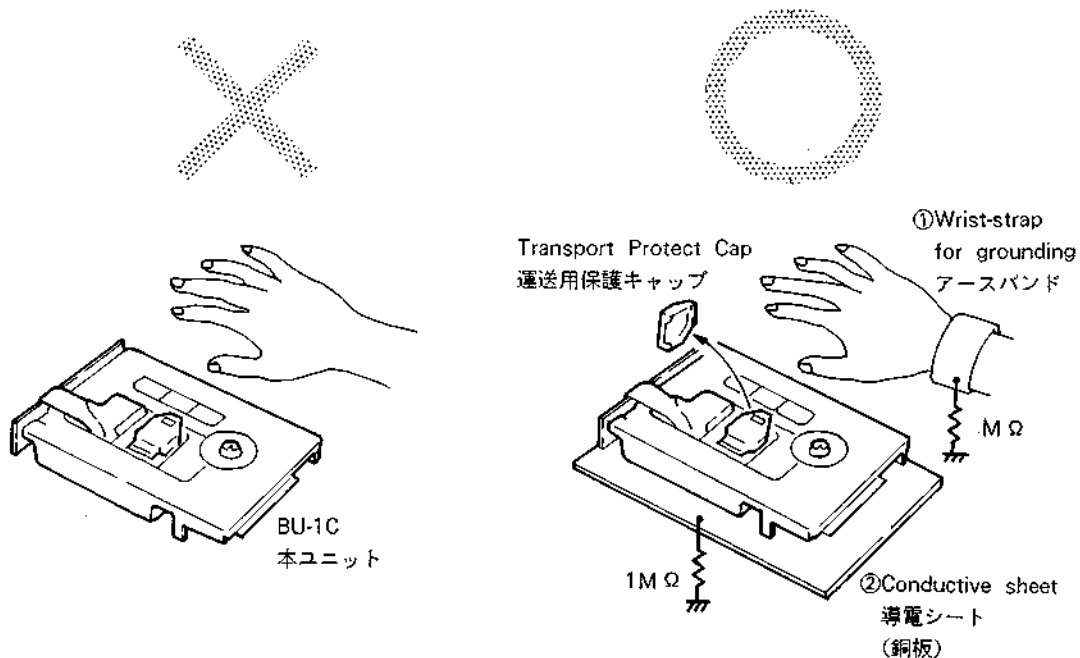

### 7. Removal of Power LED P.C. Board

- (1) Remove hooks (C) as shown in Figure 9.
- (2) Disconnect the connector from Power LED P.C. Board.

### 7. パワーLED基板の外し方

- (1) フック (C) を外します。(9図参照)
- (2) パワーLED基板から出ているコネクタを外します。

### 8. Removal of CD Mechanism

- (1) After removal of panel front, remove four screws marked "▲" as shown in Figure 7.
- (2) Disconnect all wires from CD Mechanism.

### 8. CDメカニズムの外し方

- (1) パネル・フロントを外してから、4本のネジ (▲印) を外します。(7図参照)
- (2) CDメカニズムから出ている全てのリード線を外せば、CDメカニズムは外せます。

### 9. Removal of Fuse P.C. Board (UZ, UQ, EK, MODEL ONLY)

- (1) Removal four screws marked "※" as shown in Figure 14.
- (2) Disconnect all wires from Fuse P.C. Board.

### 9. フューズ基板の外し方 (UZ、UQ及びEK向セットのみ)

### 10. Removal of Voltage Switch P.C. Board (EK MODEL ONLY)

- (1) Remove a screw marked "◎" as shown in Figure 14.
- (2) Disconnect all wires from Voltage Switch P.C. Board.

### 10. 電圧切換スイッチの外し方 (EK向セットのみ)

### 11. Removal of Power P.C. Board

- (1) Remove two screw marked "■" as shown in Figure 7.
- (2) Disconnect all wires from Power Switch P.C. Board.

### 11. パワー・スイッチ基板の外し方

- (1) 2本のネジ (■印) を外します。(7図参照)
- (2) パワー・スイッチ基板から出ている全てのリード線を外せば基板は外せます。

### 12. Removal of Remote P.C. Board

- (1) Remove two screws marked "★" as shown in Figure 7.
- (2) Disconnect the connector from Remote P.C. Board.

### 12. リモート基板の外し方

- (1) 2本のネジ (★印) を外します。(7図参照)
- (2) リモート基板から出ているコネクタを外します。

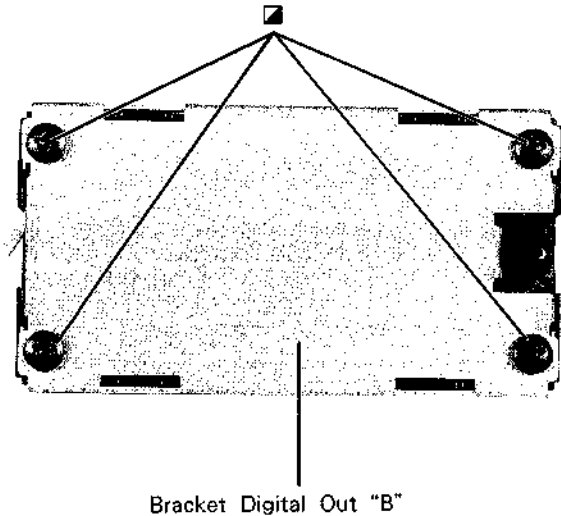

Figure 11

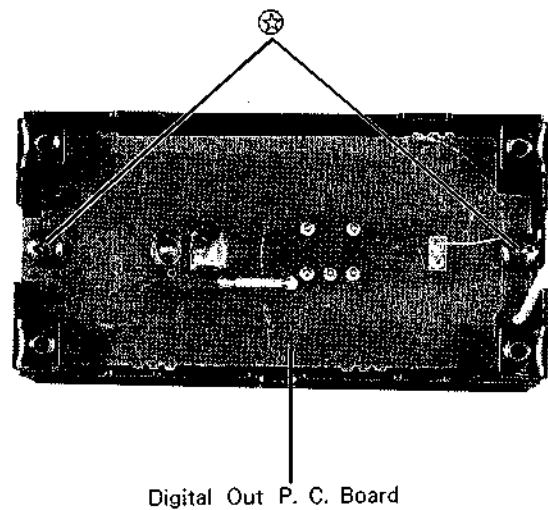

Figure 12

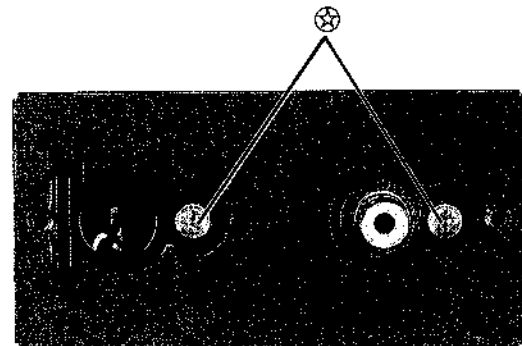

Figure 13

**13. Removal of Subcode P.C. Board**

- (1) Remove two screws marked "◇" as shown in Figure 8.
- (2) Disconnect the connector from Subcode P.C. Board.

**13. サブ・コード基板の外し方**

- (1) 2本のネジ(◇印)を外します。(8図参照)
- (2) サブ・コード基板から出ているコネクタを外せば基板は外せます。

**14. Removal of Assembly Digital Out**

- (1) Remove two screws marked "◎" as shown in Figure 10.
- (2) Disconnect a connector from Digital Out P.C. Board

**14. デジタル出力組立の外し方**

- (1) 2本のネジ(◎印)を外します。(10図参照)
- (2) デジタル出力基板から出ているコネクタを外します。

**15. Removal of Digital Out P.C. Board**

- (1) After removal of Assembly Digital Out remove four screws marked "■" as shown in Figure 11.
- (2) Remove four screws marked "⊕" as shown in Figures 12 and 13.

**15. デジタル出力基板の外し方**

- (1) デジタル出力組立を外してから、4本のネジ(■印)を外します。(11図参照)
- (2) 4本のネジ(⊕印)を外せば基板は外せます。(12、13図参照)

**16. Removal of Bracket Shield**

- (1) Remove two screws marked "⊠" as shown in Figure 7.

**16. ブラケット・シールドの外し方**

- (1) 2本のネジ(□印)を外します。(7図参照)

**17. Removal of Digital P.C. Board**

- (1) After removal of bracket shield, remove four screws marked "●" as shown in Figure 7.
- (2) Disconnect all wires from Digital P.C. Board.

**17. デジタル基板の外し方**

- (1) ブラケット・シールドを外してから、4本のネジ(●印)を外します。(7図参照)
- (2) デジタル基板から出ている全てのリード線を外せば、基板は外せます。

**18. Removal of Audio P.C. Board**

- (1) Remove five screws marked "■" as shown in Figures 7 and 10.

**18. オーディオ基板**

- (1) 5本のネジ(■印)を外せば、基板は外せます。(7、10図参照)

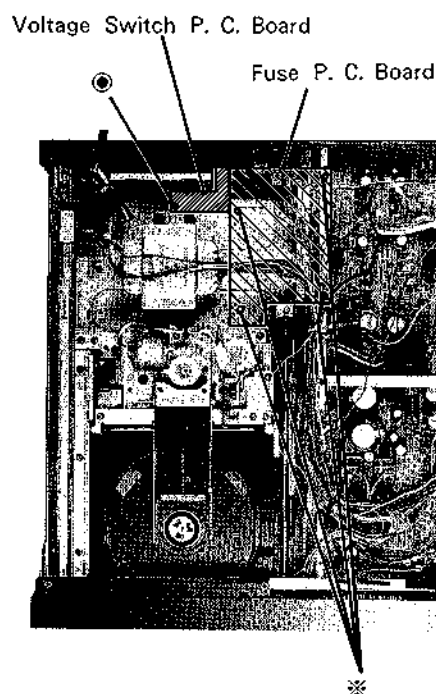

Figure 14



<Cabinet Section>

<キャビネット部>

1. Removal of Top Cover

- (1) Remove seven screws marked "○" as shown in Figures 4 and 5.
- (2) Pull out the top cover in the arrow direction as shown in Figure 4.

1. 上蓋の外し方

- (1) 7本のネジ (○印) を外します。(4、5図参照)
- (2) 矢印の方向に上蓋を引き上げれば、上蓋は外せます。(4図参照)

2. Removal of Bottom Cover

- (1) Remove eleven screws marked "X" as shown in Figure 6.

2. 底蓋の外し方

- (1) 11本のネジ (×印) を外します。(6図参照)

3. Removal of Panel Front

- (1) After removal of top cover and bottom cover, remove ten screws marked "△" as shown in Figures 7 and 8.
- (2) Disconnect all connectors from FL-Keyboard P.C. Board, Volume/Switch P.C. Board, Head Phone P.C. Board and Power LED P.C. Board.
- (3) Panel front with each P.C. Board can be removed completely.

3. フロント・パネルの外し方

- (1) 上蓋と底蓋を外してから、10本のネジ (△印) を外します。(7、8図参照)
- (2) FL・キーボード基板、ボリューム/スイッチ基板、ヘッド・ホン基板とパワーLED基板から出ている全てのコネクタを外します。
- (3) フロント・パネルには、各基板がついたまま外れます。

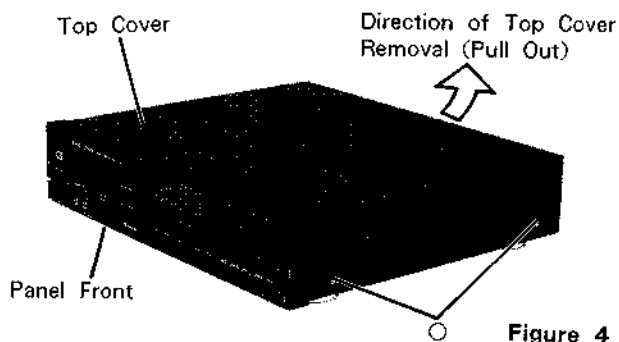

Figure 4

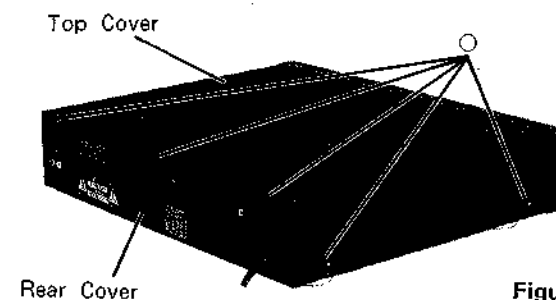

Figure 5

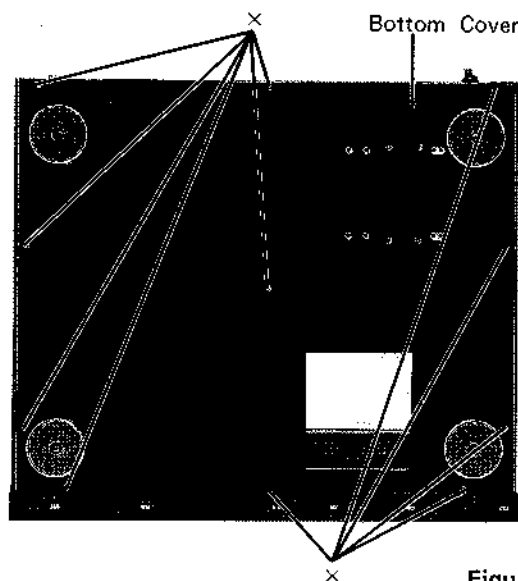

Figure 6

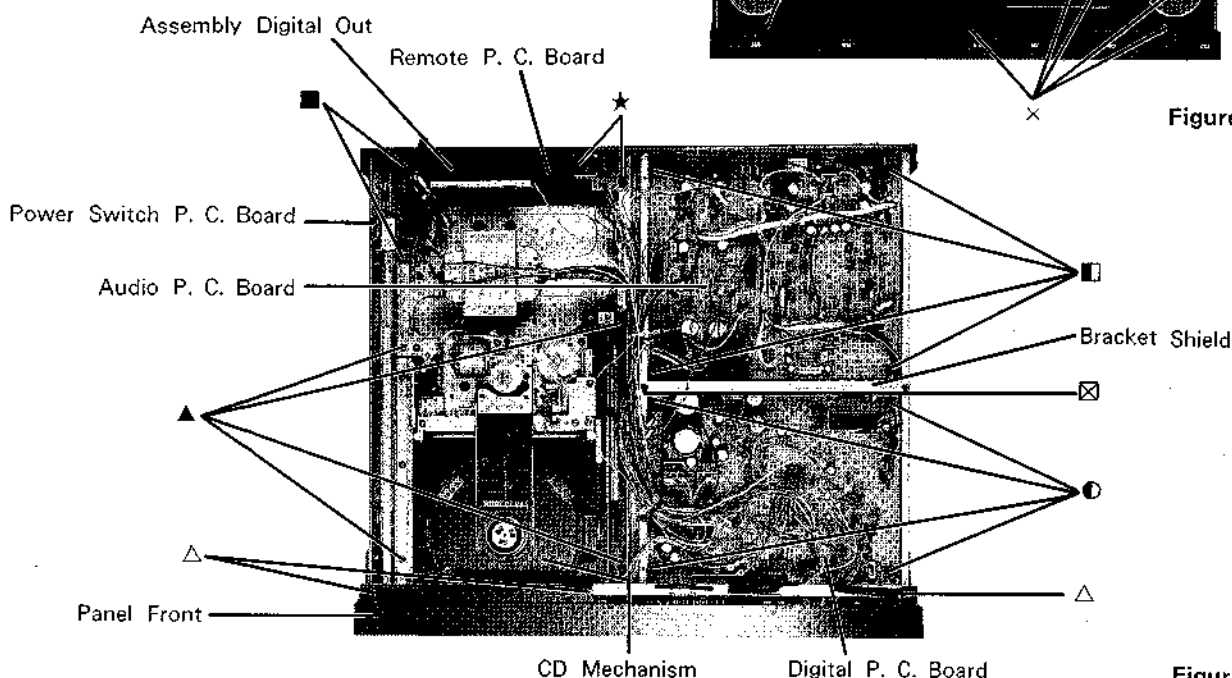

Figure 7

**4. Removal of FL-Keyboard P.C. Board**

- (1) After removal of the panel front remove three screws marked "□" and hooks (A) as shown in Figure 9.
- (2) Disconnect a connector from Volume/Switch P.C. Board

**4. FL-キーボード基板の外し方**

- (1) パネル・フロントを外してから、3本のネジ (□印) とフック (A) を外します。(9図参照)
- (2) ボリューム/スイッチ基板から出ているコネクタを外せば、FL-キーボード基板は外すことができます。

**5. Removal of Head Phone P.C. Board**

- (1) Remove two screws marked "●" as shown in Figure 9.
- (2) Disconnect a connector from Volume/Switch P.C. Board.

**5. ヘッド・ホン基板の外し方**

- (1) 2本のネジ (●印) を外します。(9図参照)
- (2) ボリューム/スイッチ基板から出ているコネクタを外せばヘッド・ホン基板は、外せます。

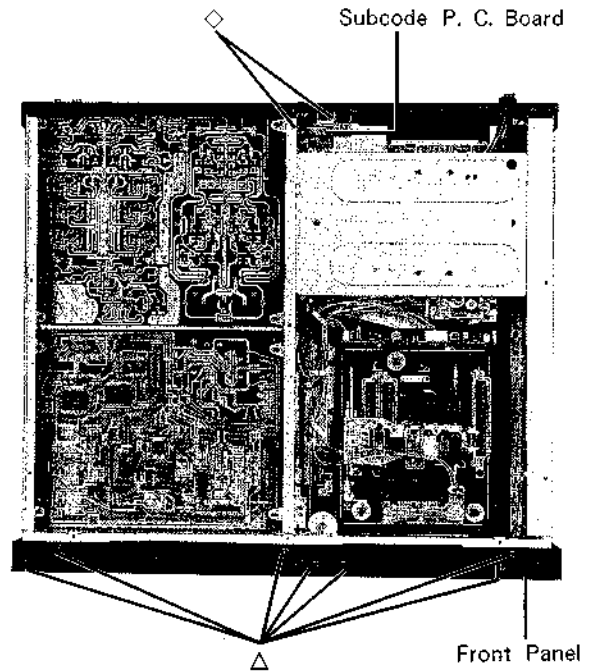

Figure 8

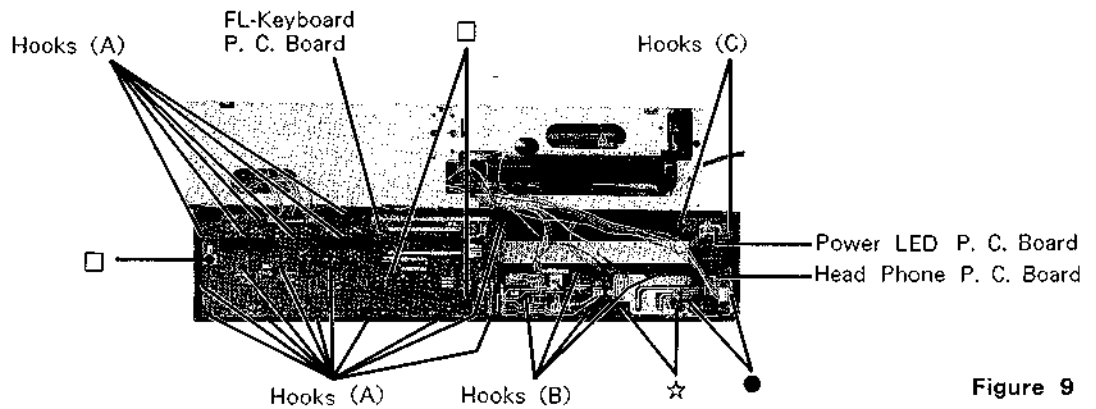

Figure 9

**6. Removal of Volume/Switch P. C. Board.**

- (1) After removal of FL-Keyboard P.C. Board and Head Phone P.C. Board remove two screws marked "☆" and hooks (B) as shown in Figure 9.
- (2) Disconnect a connector from Volume/Switch P.C. Board.

**6. ボリューム/スイッチ基板**

- (1) FL-キーボード基板とヘッド・ホン基板を外してから、2本のネジ (☆印) と、フック (B) を外します。(9図参照)
- (2) ボリューム/スイッチ基板から出ているコネクタを外せばヘッド・ホン基板は、外せます。

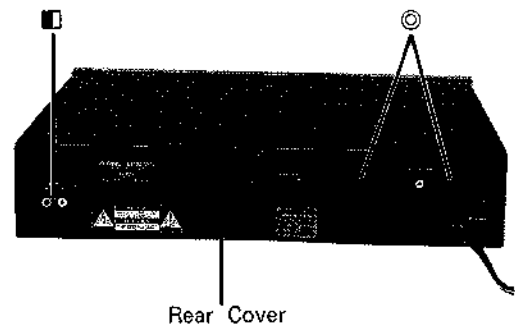

Figure 10

< CD Mechanism Section >  
< CDメカニズム部 >

- Follow numbers circled when disassembling.
- 図中に①など番号のあるものは、その番号順に外す。

1. Removal of IN SW P.C. Board and  
L.C. SW P.C. Board

1. IN SW基板及びL.C. SW基板の外し方

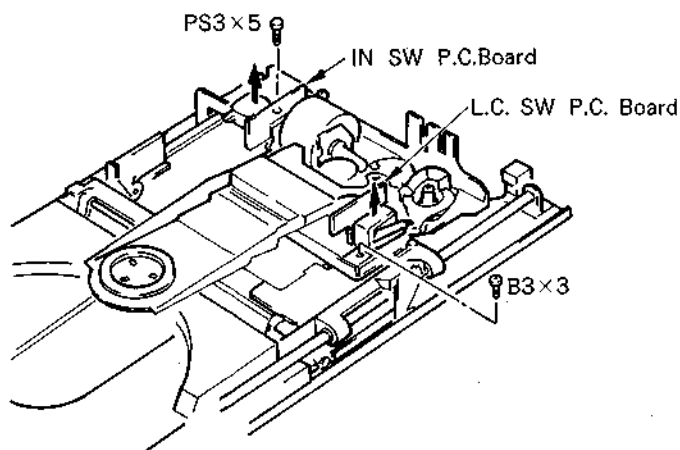

Figure 15

2. Removal of Chucking Motor (M651)

2. チャッキング・モーター (M651) の外し方

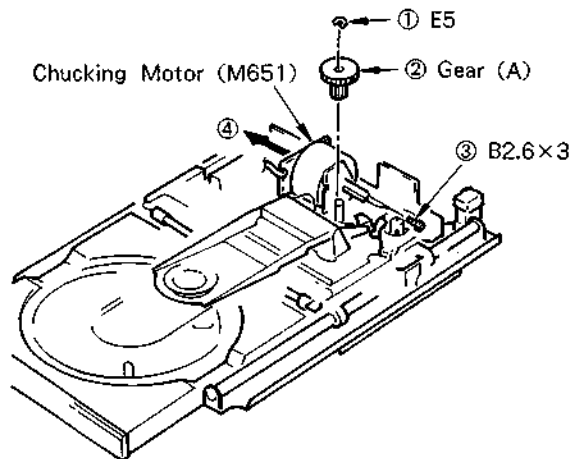

Figure 16

3. Removal of Loading Motor (M652), FF Belt, Drive  
Belt and Load Out Switch P.C. Board.

3. ローディングモーター (M652)、FFベルト、  
駆動ベルト及びLOAD OUT SW基板の外し方

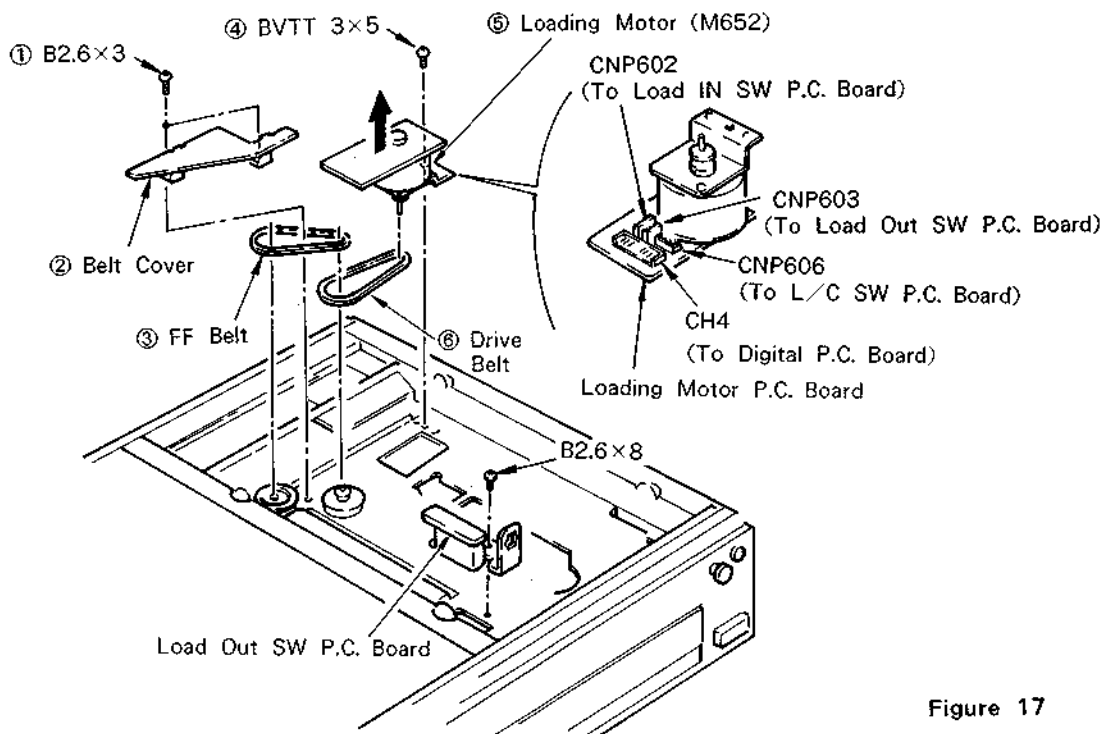

Figure 17

4. Removal of Base Unit (BU-IC)

4. BU-IC (ベース・ユニット) の外し方

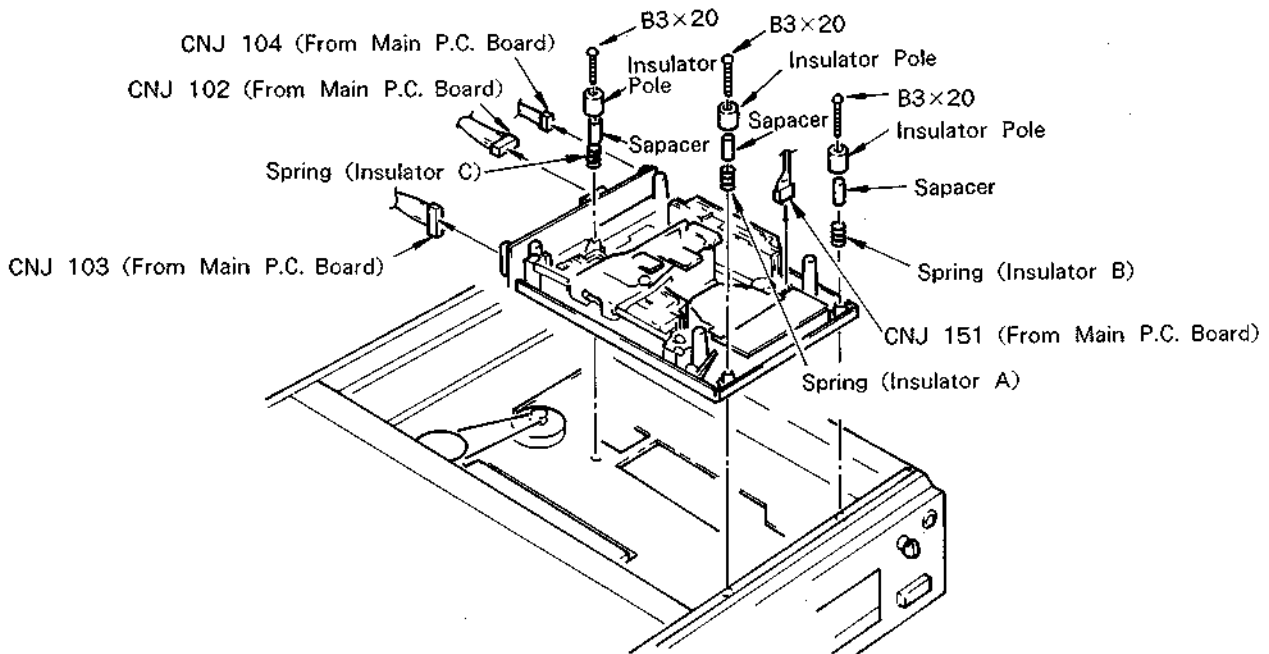

Figure 18

**Note (1):** When replacing the base unit, please refer to "Note on Handling Base Unit (BU-IC)", page 5, to avoid electrostatic breakdown.

**Note (2):** Dimensions vary in each spring (insulator). When assembling them, please refer to the chart shown below.

Coil Spring (Insulator)	Turn	Color
A	6	Silver
B	4.5	Gold
C	3.5	Black

注意 (1): ベースユニット交換 時には、静電気破壊防止のため、「BU-1C (ベースユニット) 取扱時の注意」3 ページを参照して下さい。

注意 (2): 各圧縮コイルバネ (インシュレーター) には、寸法または巻数がちがいます。取付ける場合は、下記の表を確認の上取付けて下さい。

圧縮コイルバネ (インシュレーター)	巻数	色
A	6	銀
B	4.5	金
C	3.5	黒

5. Removal of Optical Pick-up Block

5. 光学系ブロックの外し方

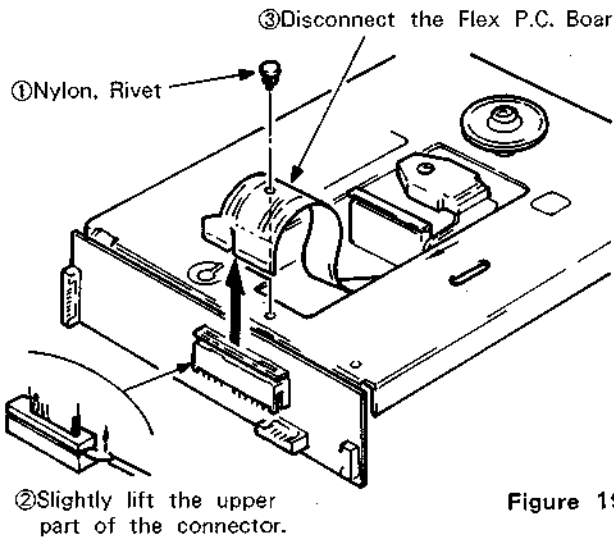

Figure 19

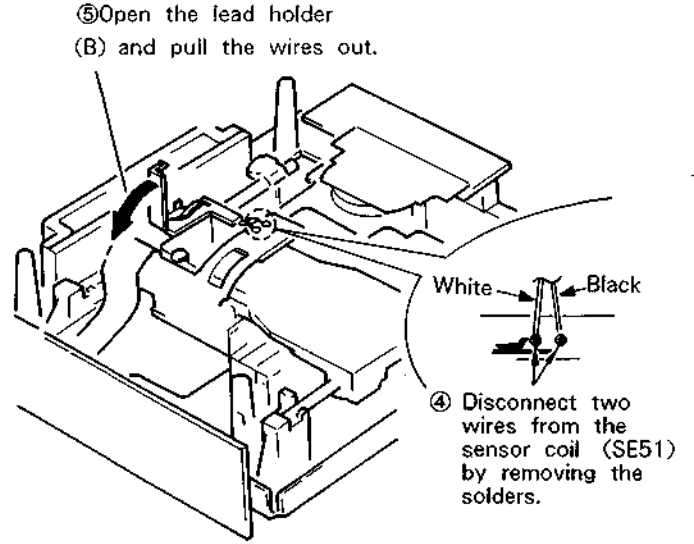

Figure 20

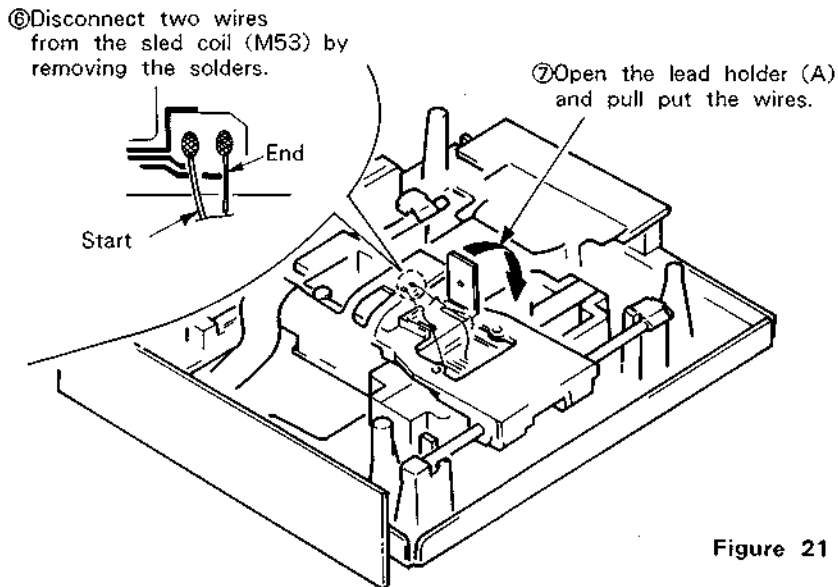

Figure 21



Figure 22

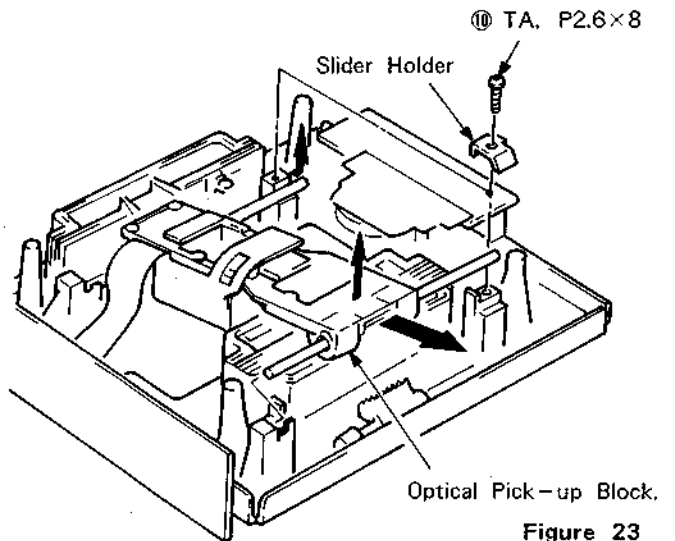

Figure 23

6. Removal of Sled Coil (M53) and Sensor Coil (SE51)

- ①, ② : Sensor Coil (SE51)
- ③~⑥ : Sled Coil (M53)

6. スレッドコイル (M53)、センサーコイル (SE51) の外し方

- ①, ② : センサーコイル (SE51)
- ③~⑥ : スレッドコイル (M53)

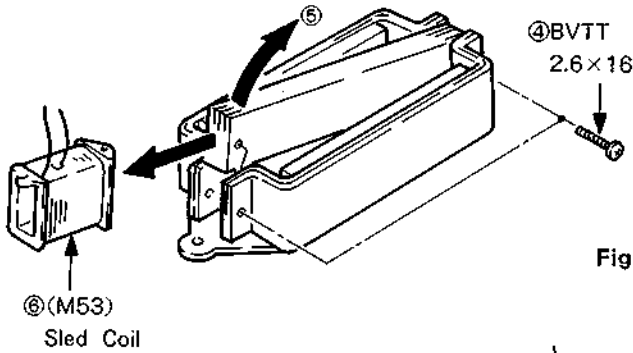
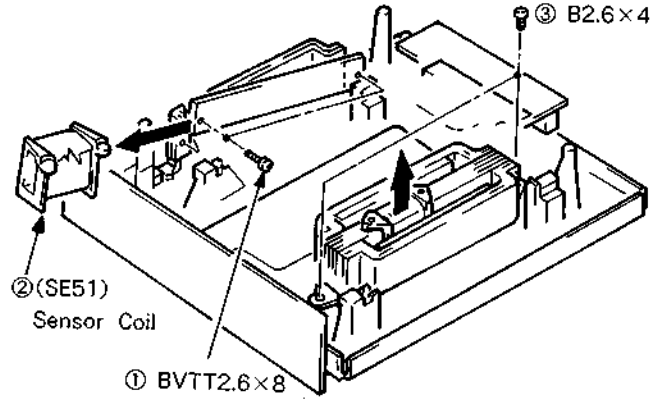
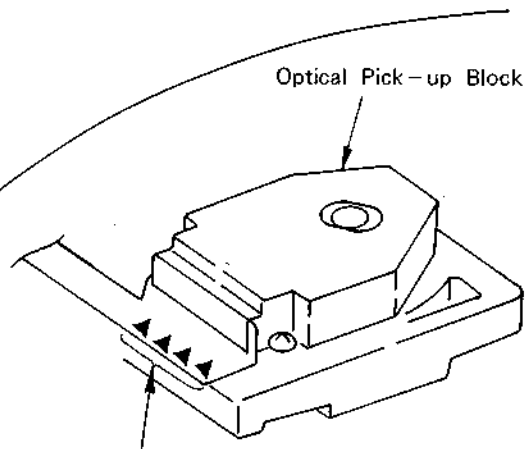
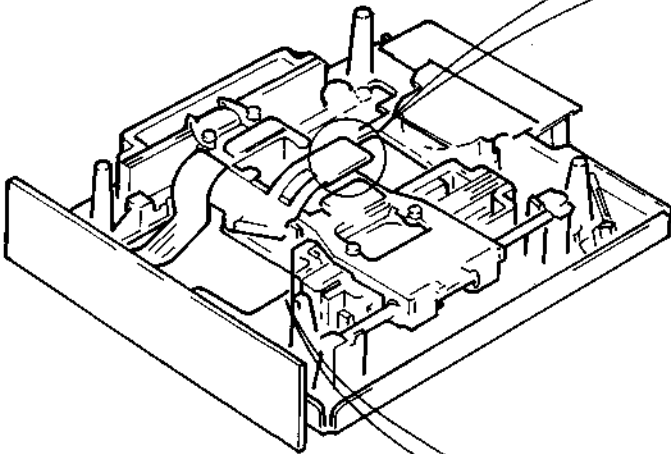
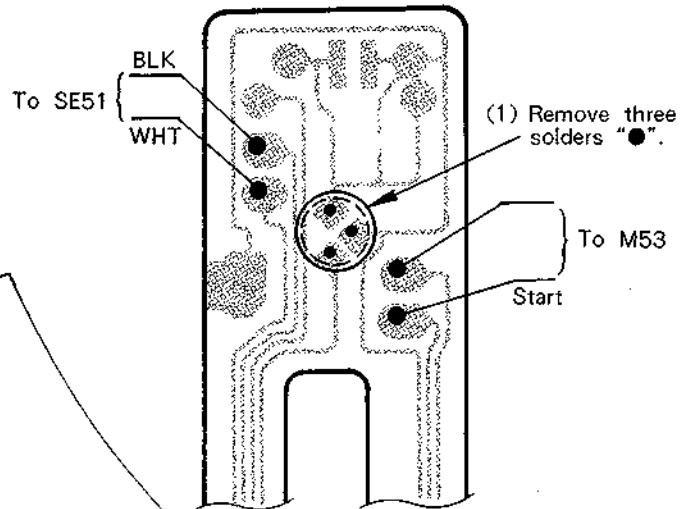

Figure 24

7. Removal of Flexible P.C. Board

7. フレキシブル基板の外し方



(2) Remove four solders "▲".

Figure 25

Note: Don't remove two screws.

These screws fasten the detector.

Removal or unfastening cause wrong alignments of the detector that fails to receive the laser beam.

注意： このねじは外さないこと。

このねじはディテクターを固定しているため、外したり、ゆるめたりするとディテクターの位置が狂いレーザー光を受光できなくなります。

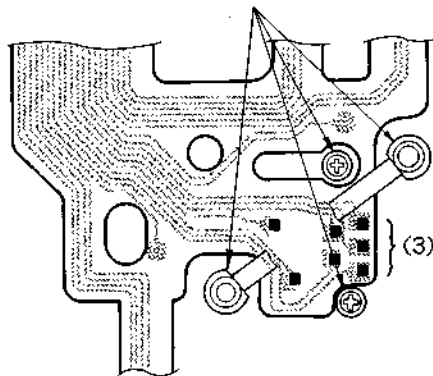

(3) Remove seven solders "■".

Figure 26

# Troubleshooting Guide

## ● Flow Chart for Troubleshooting of BU-1C (Base Unit).

- Check the connections around the BU-1C (Base Unit) before proceeding the checks below.

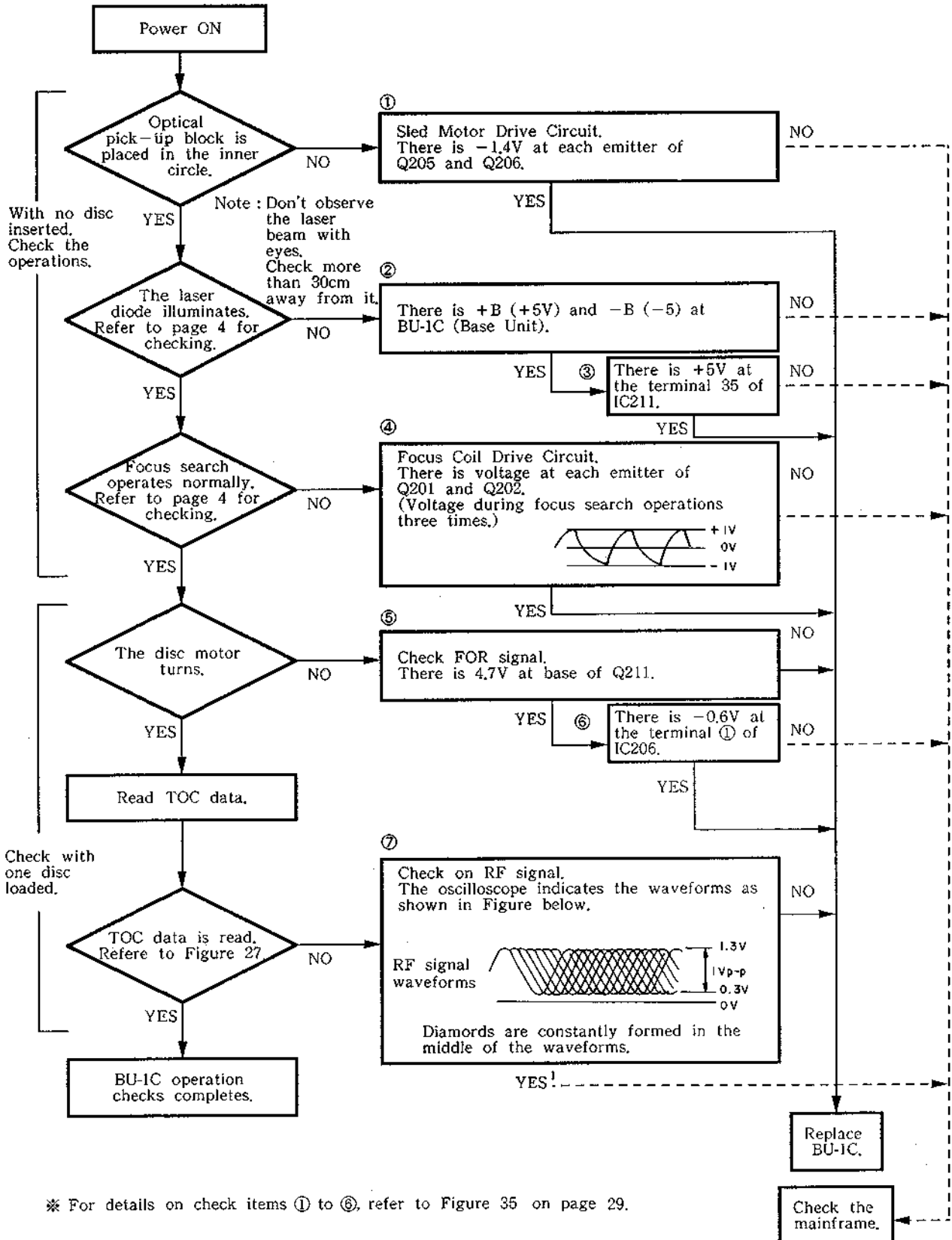



## Adjustment Procedures

- BU-1C (Base Unit)
- Check TOC Data is Read.

If the TOC data is read normally, the total track numbers and playback time of the disc are indicated on the display. With the test disc YEDS-1, data is displayed as shown below.

- BU-1C (ベースユニット)
- TOC情報が読めたかの確認

TOC情報が正常に読めれば、表示部にそのディスクの曲数と曲の合計時間が表示されます。

ディスクがYEDS-1の場合は、次のように表示されます。

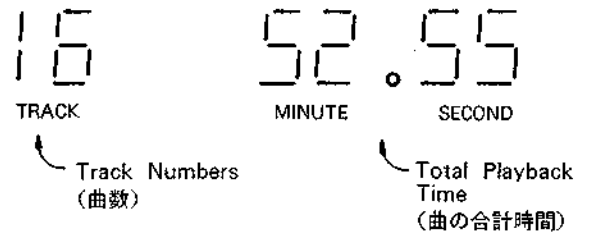
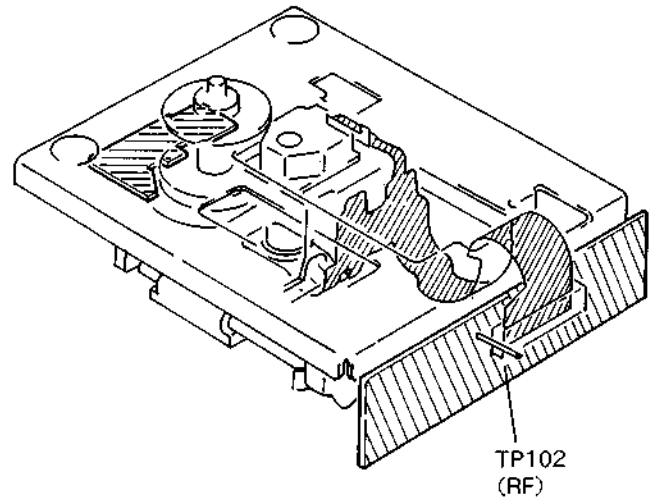

Figure 27

- Adjustment of Chucking Arm Level

After loading a disc and closing the disc table adjust the screw for the height (A) as shown in Figures 28.

- チャッキングアーム高さ調整

ディスクを入れてディスクテーブルを閉じた状態で、28図のように(A)部の高さを調整する。

(Confirmation)

Load several times and see if the chucking arm and the disc arm don't touch.

(確認)

LOADINGをくり返し、チャッキングアームとディスクプリーが接触しない事を確認する。

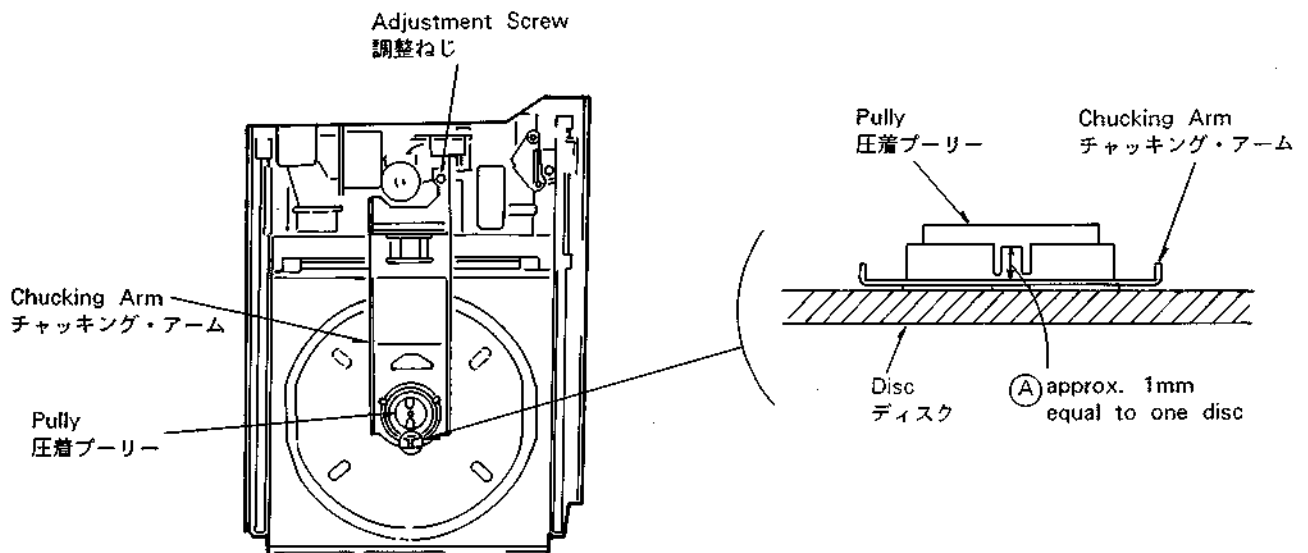

Figure 28



### III. Focus Gain Adjustment

#### 1. Adjustment Procedures

- (1) Set the 1K ohm resistor on the Focus Servo signal line as shown in Figure 34 connect CB102 from the digital P.C. Board as shown in Figure 30.
- (2) After switching the power on, load a disc and set the to play mode.
- (3) When the oscillator reads 500mV at 1.2KHz, adjust VR201 for the both ends of the resistors (T.P. 6 and T.P. 7) to obtain respectively 500mV.

### IV. Distortion Adjustment

#### 1. Connections

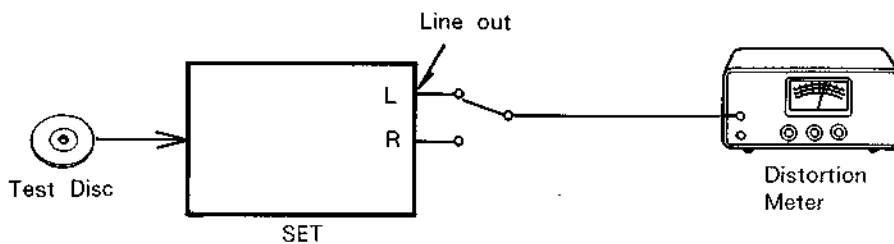

Figure 31

#### 2. Adjustment Procedures

- (1) After Connecting the set as shown in Figure 31 and switching the power on, load a disc and set the unit to play mode.
- (2) Adjust VR4101 for the distortion value to show minimum.

## 調整方法

### I. PLL 調整

#### 1. 接続図

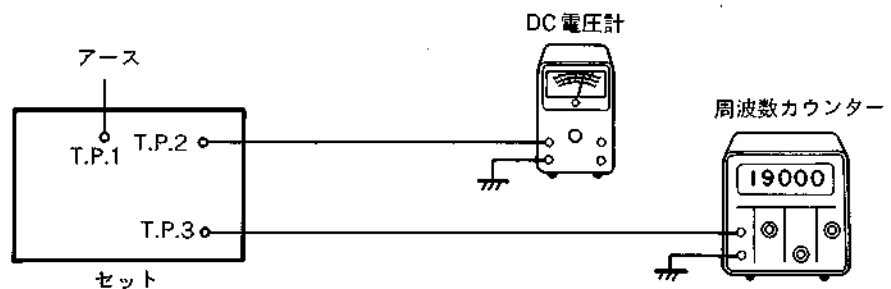

29図

#### 2. 調整方法

- (1) DIGITAL 基板のCB102のコネクターを引き抜き29図のように接続する。
- (2) PowerスイッチをONした後、TP2の電圧が0V±50mVになるようにVR203を調整します。
- (3) さらに、TP3の周波数の値が、4.3218MHz±10KHzになるようにL201を調整します。

## I. PLL Adjustment

### 1. Connections

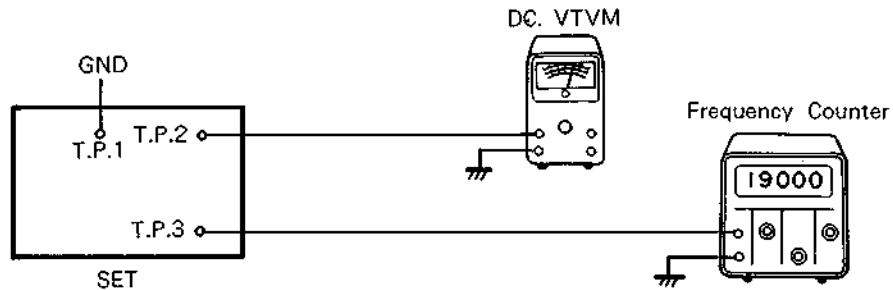

Figure 29

### 2. Adjustment Procedures

- (1) Disconnect the connector CB102 of the digital P. C. Board and connect as shown in Figure 29.
- (2) After switching the power on, adjust VR203 for T.P. 2 voltage to obtain  $0 \pm 50\text{mV}$
- (3) Also adjust L201 for frequency at T.P. 3 to obtain  $4.3218\text{Hz} \pm 10\text{KHz}$ .

## II. Tracking Gain Adjustment

### 1. Connections

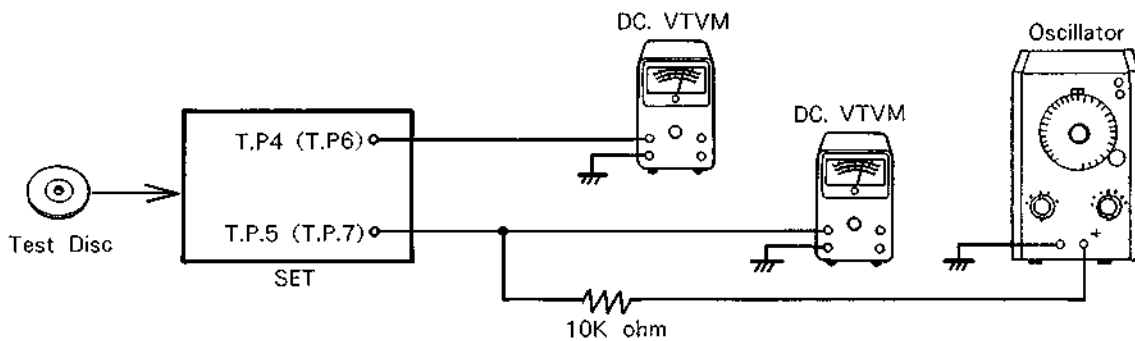

Figure 30

### 2. Adjustment Procedures

- (1) Disconnect CB102 of the digital P.C. Board. After setting the 1K ohm resistor on the tracking signal. Line as shown in Figure 34 connect the unit as shown in Figure 30.
- (2) Switch the power on, load a disc and set the unit to Play mode.
- (3) When the oscillator indicates 500mV at 1.2 KHz, adjust VR202 for voltages of the both ends of the resistor (T.P. 4 and T.P. 5) to obtain 500mV respectively.

## II. トラッキング・ゲイン調整

### 1. 接続図

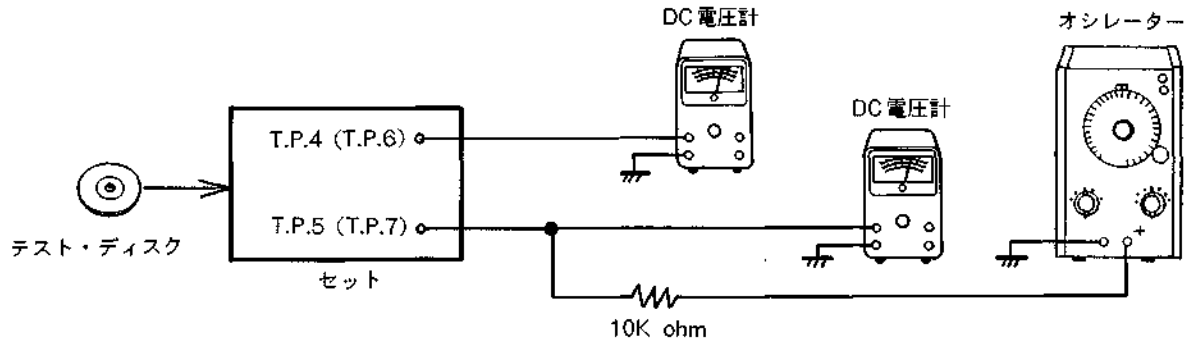

30 図

### 2. 調整方法

- (1) DIGITAL基板のCB102のコネクターを引き、34図のようにトラッキングの信号ラインに1K ohmの抵抗を挿入し、30図のように接続します。
- (2) PowerスイッチをONした後、DISCを挿入しPLAY状態にします。
- (3) オシレーターの出力が1.2KHz、500mVのとき、挿入した抵抗の両端のTP4、TP5の電圧がそれぞれ500mVになるようにVR202を調整します。

## III. フォーカスゲイン調整

### 1. 調整方法

- (1) DIGITAL基板のCB102のコネクターを引き抜き、34図のようにフォーカスサーボの信号ラインに、1K ohmの抵抗を挿入し、30図のように接続します。
- (2) PowerスイッチONした後、DISCを挿入し、PLAY状態にします。
- (3) オシレーターの出力が1.2KHz、500mVのとき、挿入した抵抗の両端のTP6、TP7の電圧がそれぞれ500mVになるようにVR201を調整します。

## IV. 歪率調整

### 1. 接続図

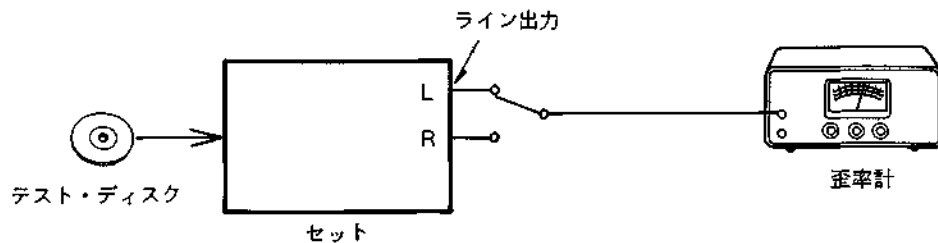

31 図

### 2. 調整方法

- (1) 31図のように接続し、PowerスイッチをONし、DISCを挿入してPLAY状態にする。
- (2) 歪率計の値が最小になるようにVR4101を調整します。

# Adjustment Locations

調整箇所

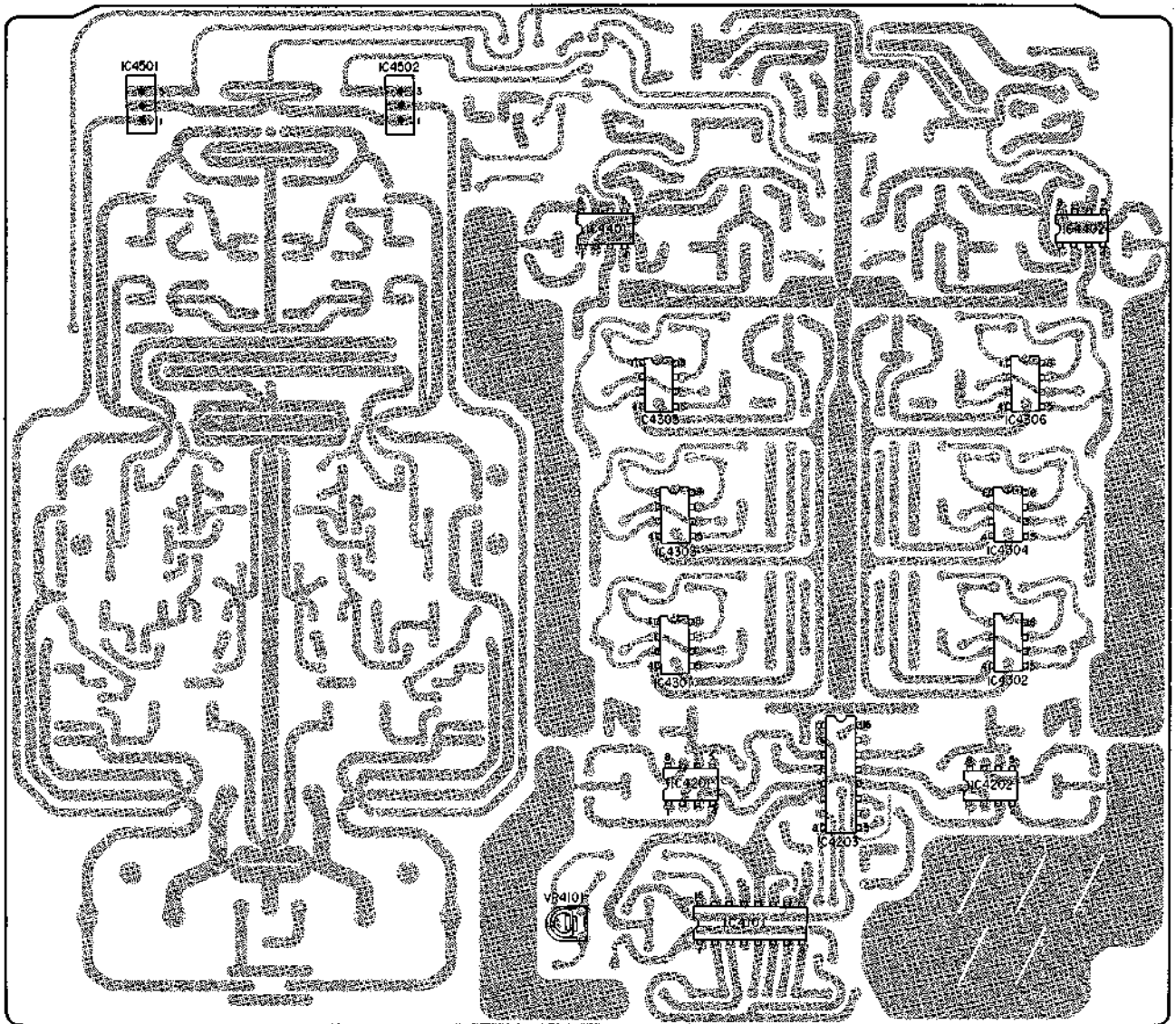
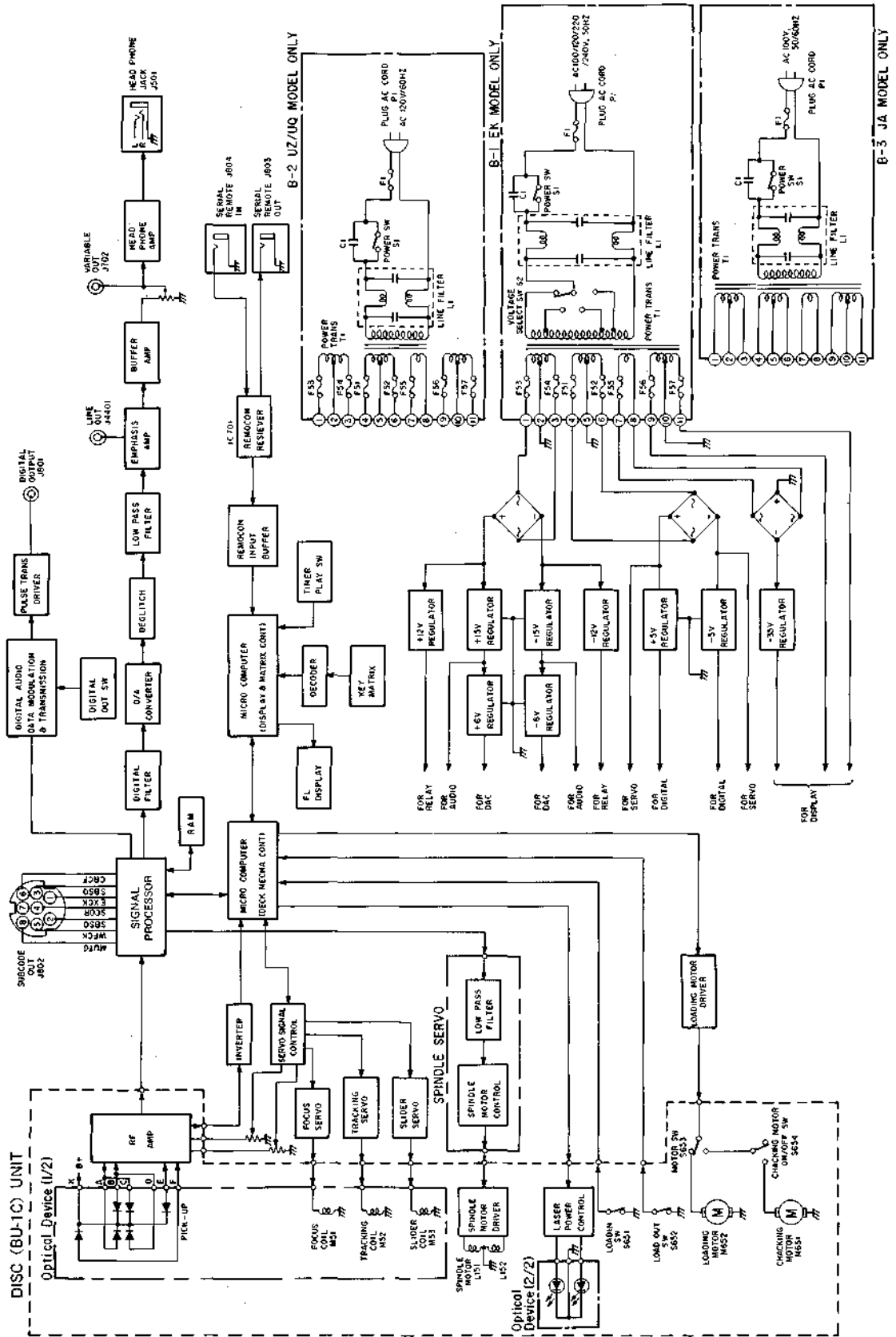

Figure 32

32図

Audio P.C. Board  
オーディオ基板

# Block Diagram



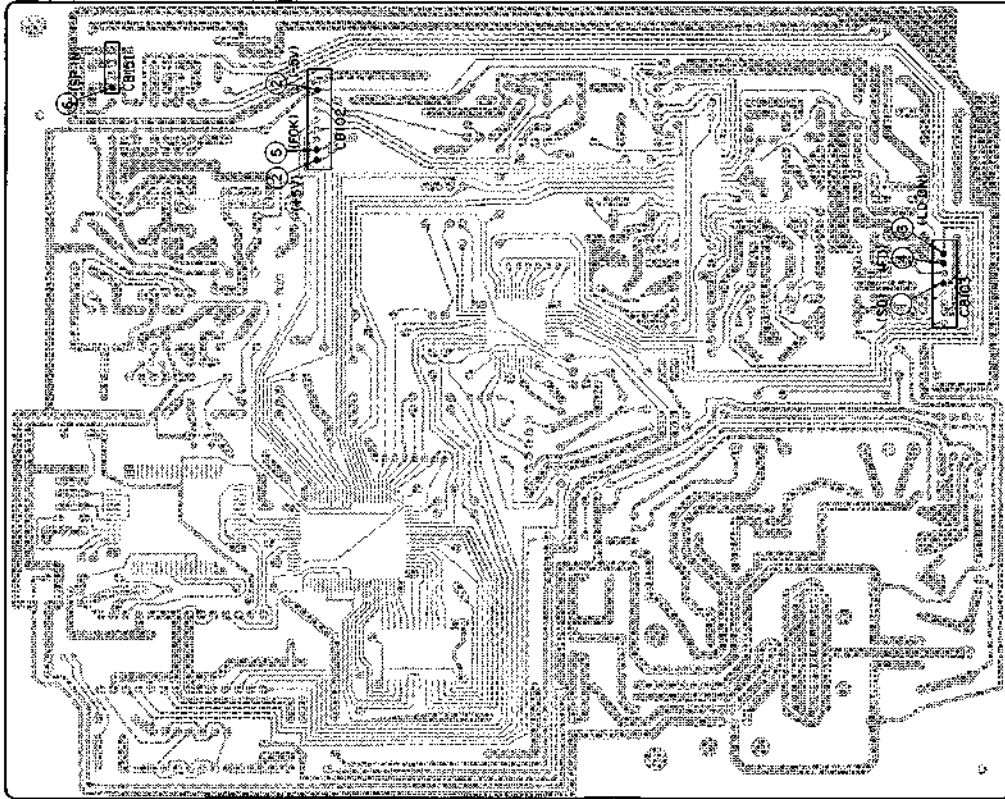

Top View 部品取付側

Figure 33  
33図

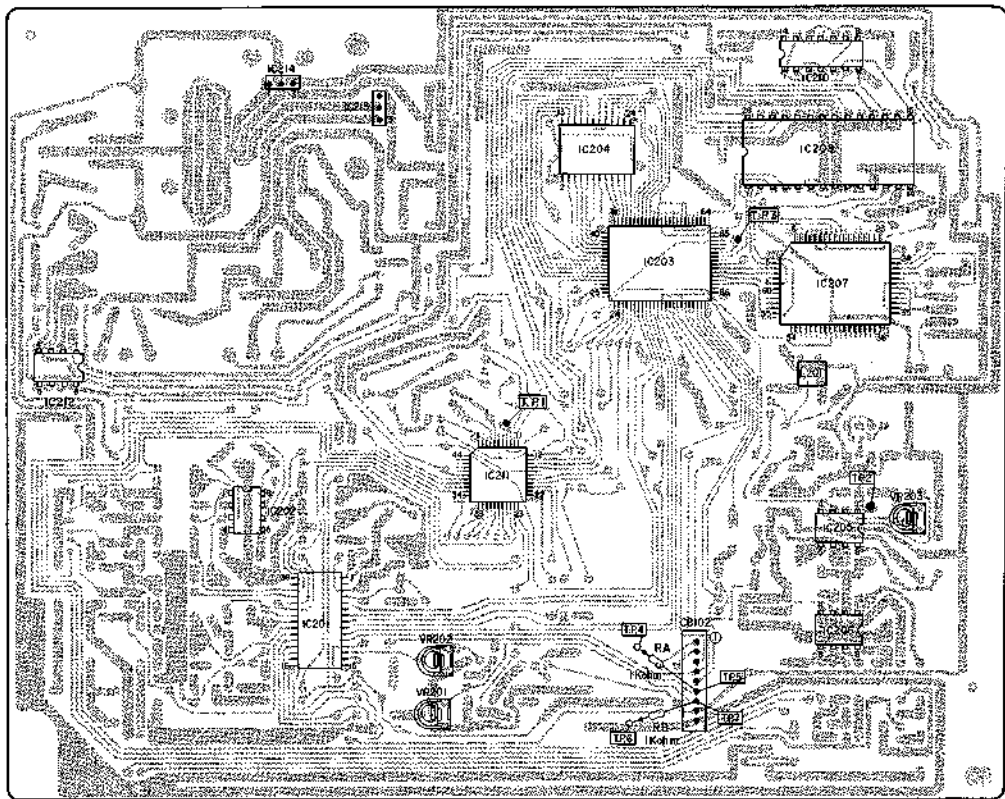

Bottom View パターン側  
Digital P.C. Board デジタル基板

Figure 34  
34図

※Use RA and RB when only adjusting.  
Connect RA to TE pin (CNJ102) on RF P. C. Board.  
Connect RB to FE pin (CNJ102) on RF P. C. Board.

※RA, RBは、調整時のみ使用  
RAは、RF基板・CNJ102のTE端子へ接続  
RBは、RF基板・CNJ102のFE端子へ接続



# Parts Layout on P.C. Boards and Wiring Diagram (1/2)

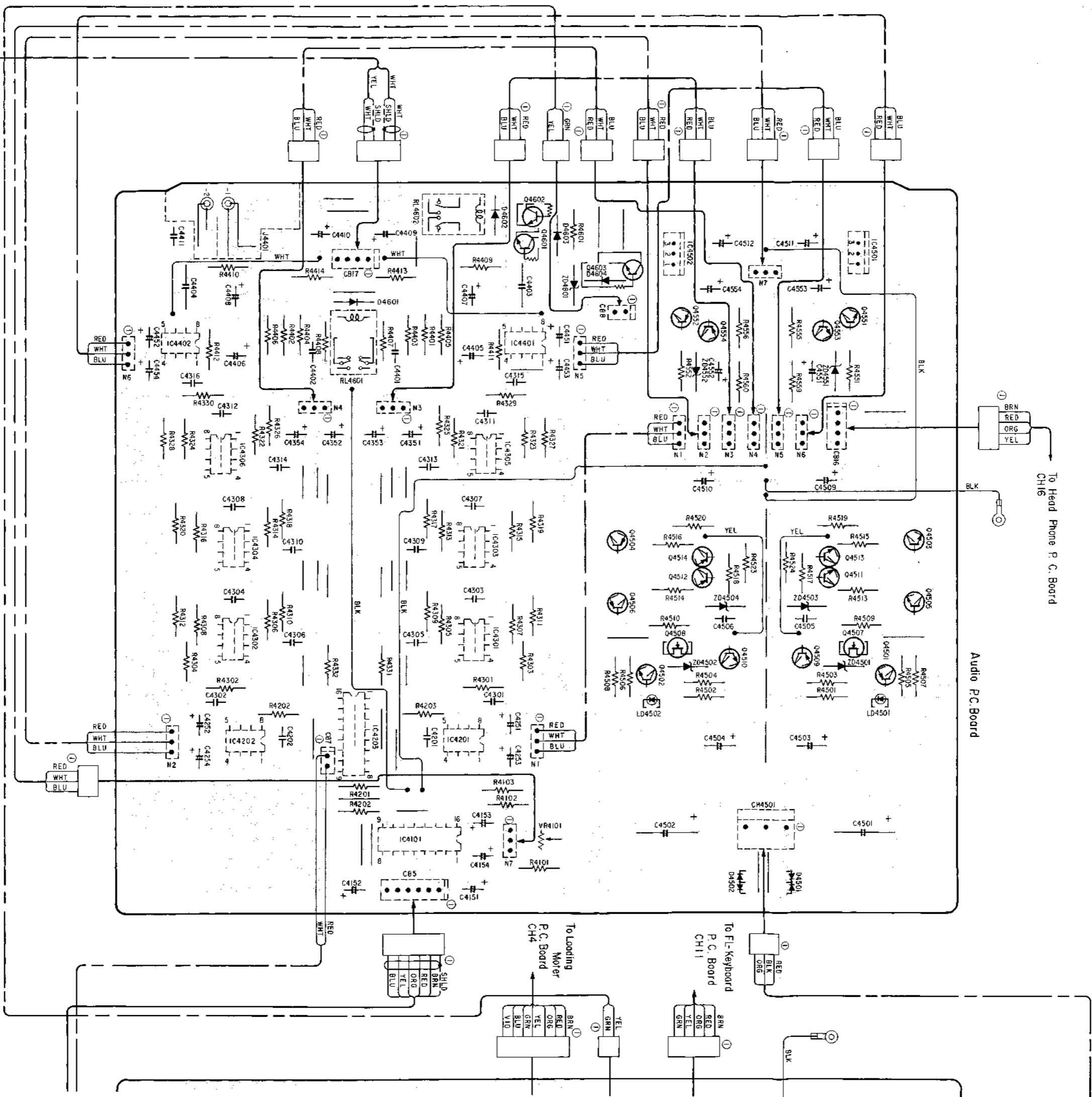

To Volume / Switch P.C. Board  
CH17

To Head Phone P.C. Board  
CH16

Audio P.C. Board

To FL-Keyboard  
P.C. Board  
CH11

To Loading  
Motor  
P.C. Board  
CH4

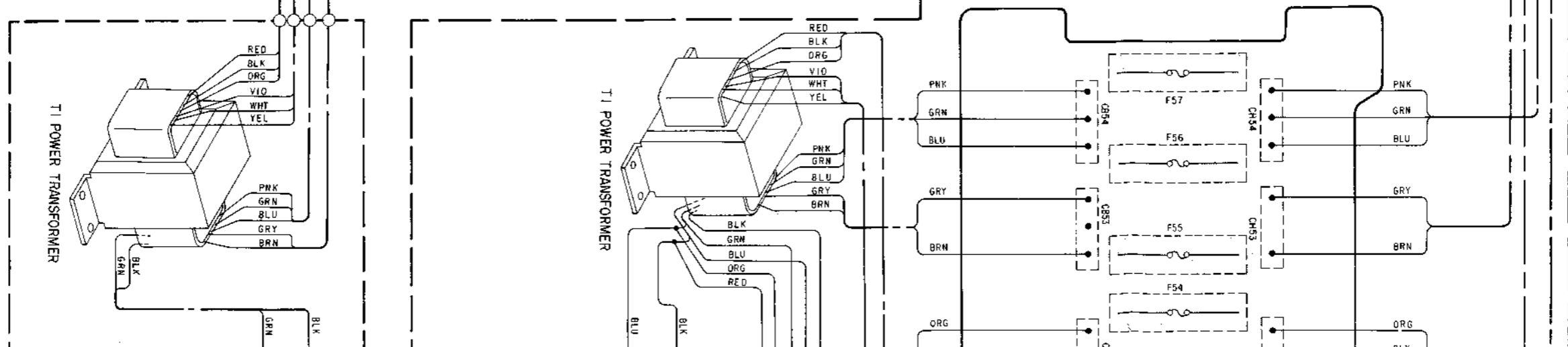
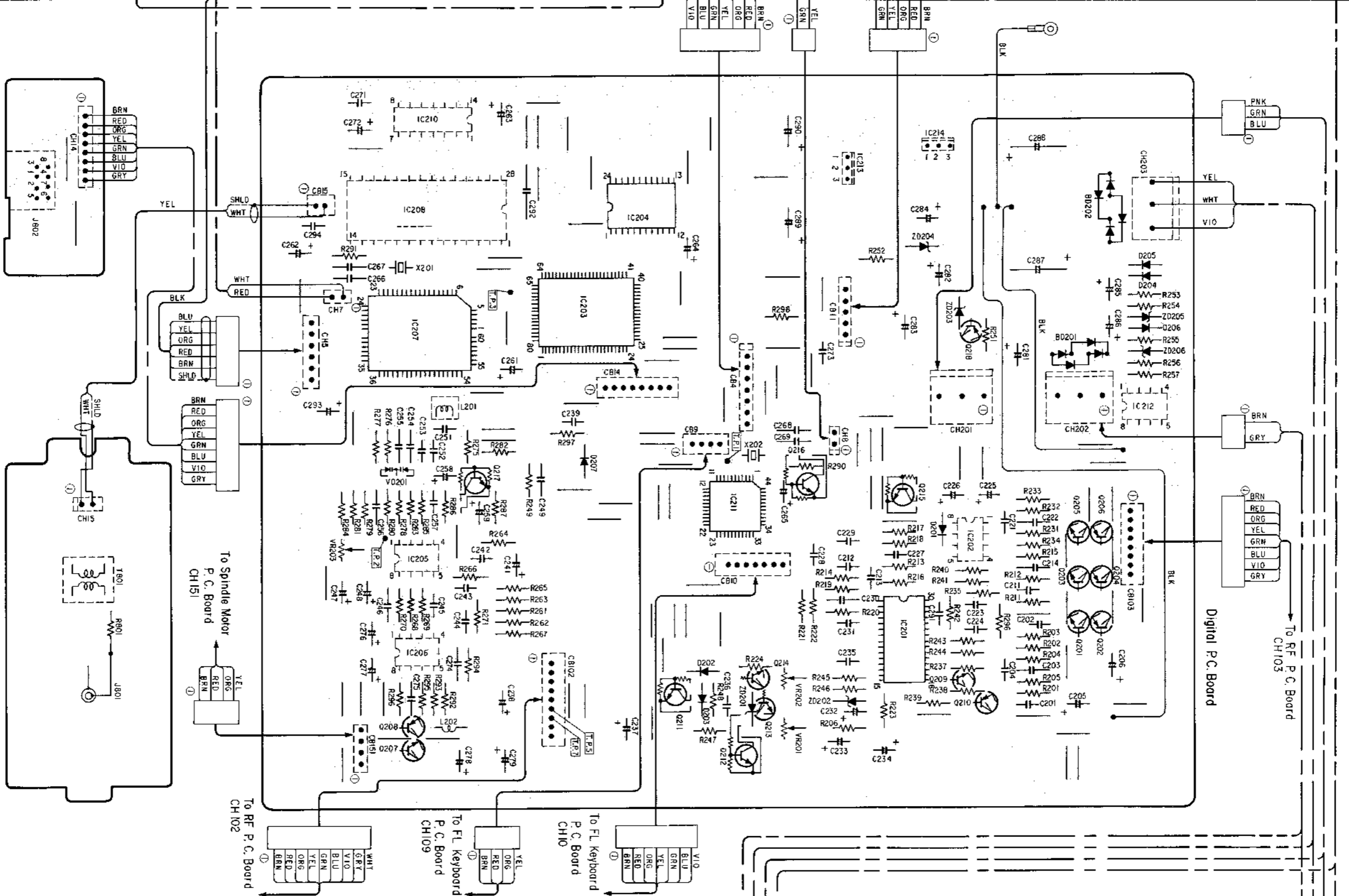

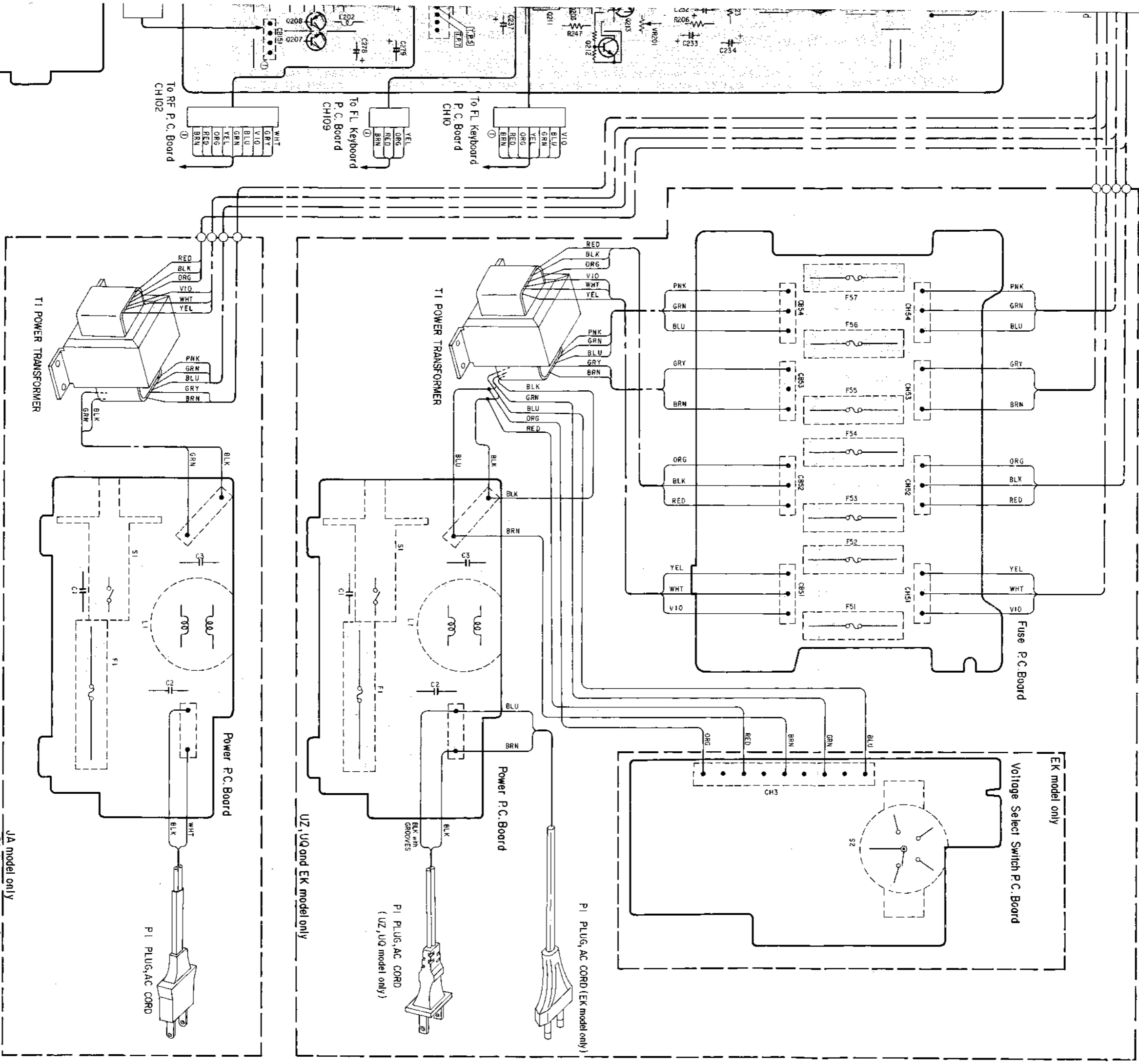

JA model only		EK model only	
BLU	Blue	BLU	Blue
GRN	Green	GRN	Green
BLK	Black	BLK	Black
GRY	Gray	GRY	Gray
WHT	White	WHT	White
RED	Red	RED	Red
BRN	Brown	BRN	Brown
ORG	Orange	ORG	Orange
YEL	Yellow	YEL	Yellow
VIO	Violet	VIO	Violet
PNK	Pink	PNK	Pink
GRN/WHT	Green/White	GRN/WHT	Green/White
GRY/WHT	Gray/White	GRY/WHT	Gray/White
GRY/YEL	Gray/Yellow	GRY/YEL	Gray/Yellow
GRN/YEL	Green/Yellow	GRN/YEL	Green/Yellow
SHLD.	Shield	SHLD.	Shield



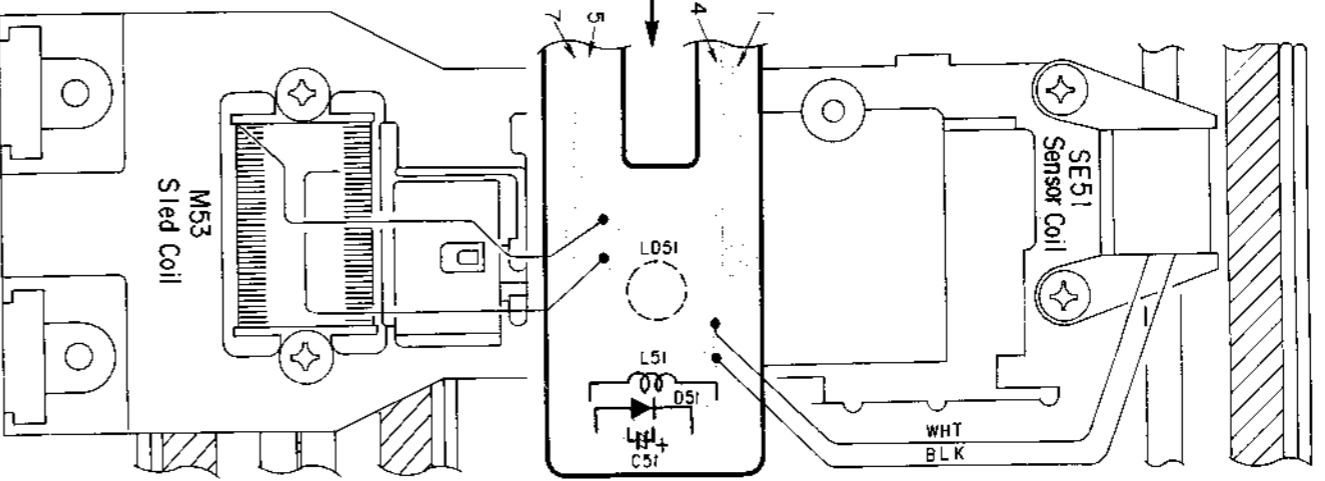

Flexible P.C. Board (1/4) bottom view

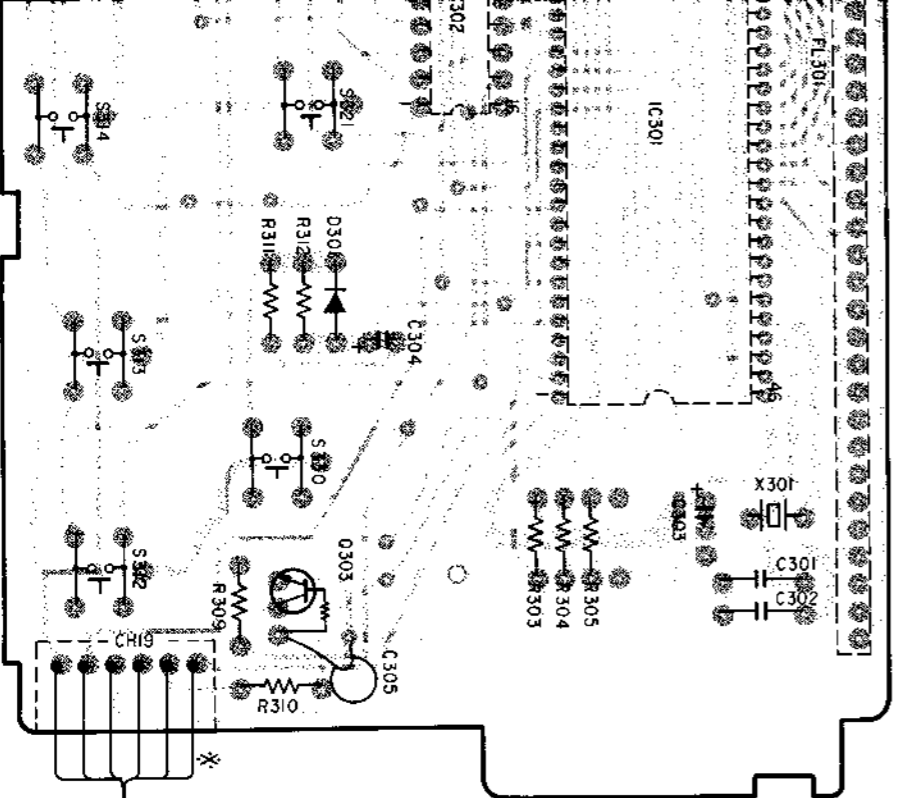

M651

Chuckling Motor P.C. Board

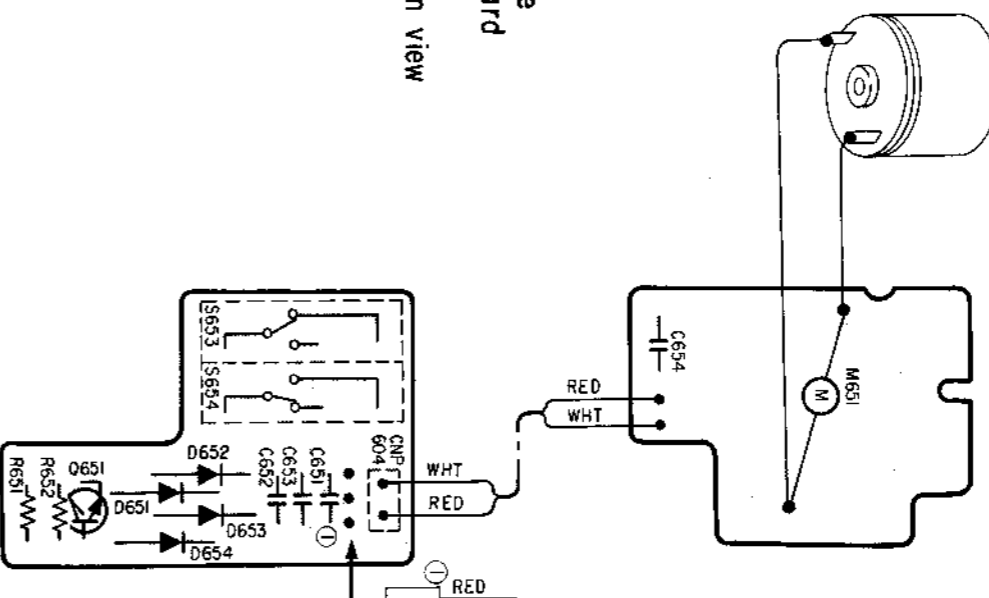

L/C Switch P.C. Board

Loading Motor P.C. Board

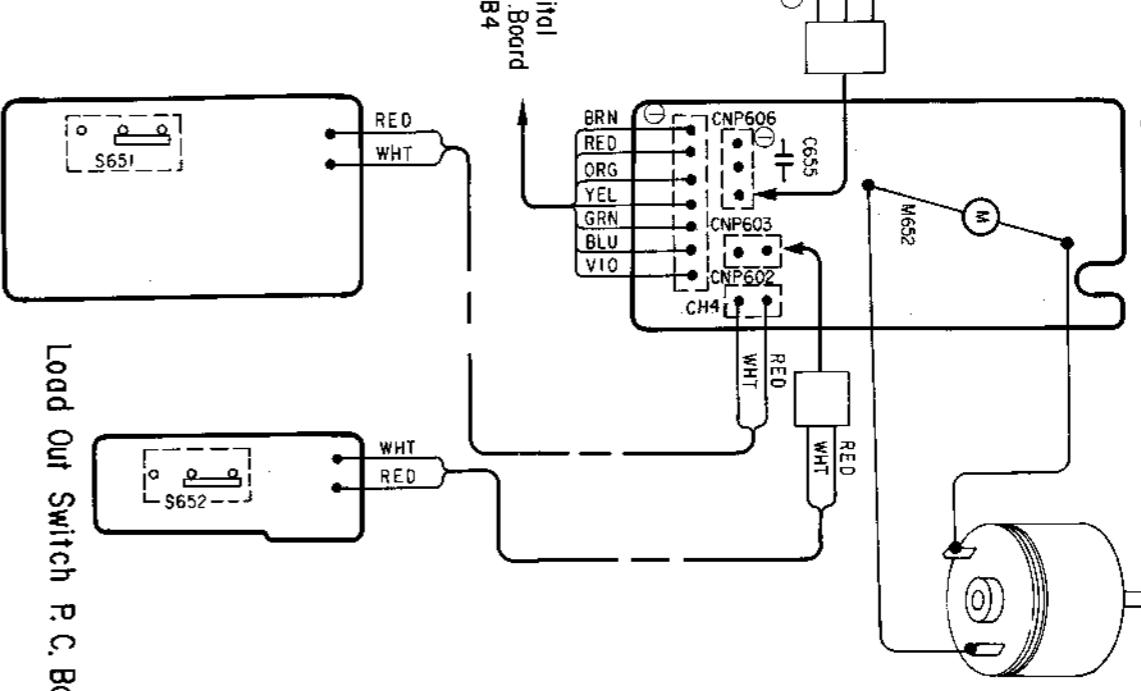

Load In Switch P.C. Board

Load Out Switch P.C. Board

Remote P.C. Board

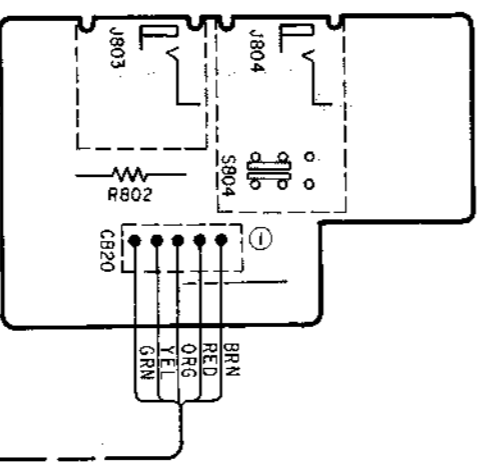

Power LED P.C. Board

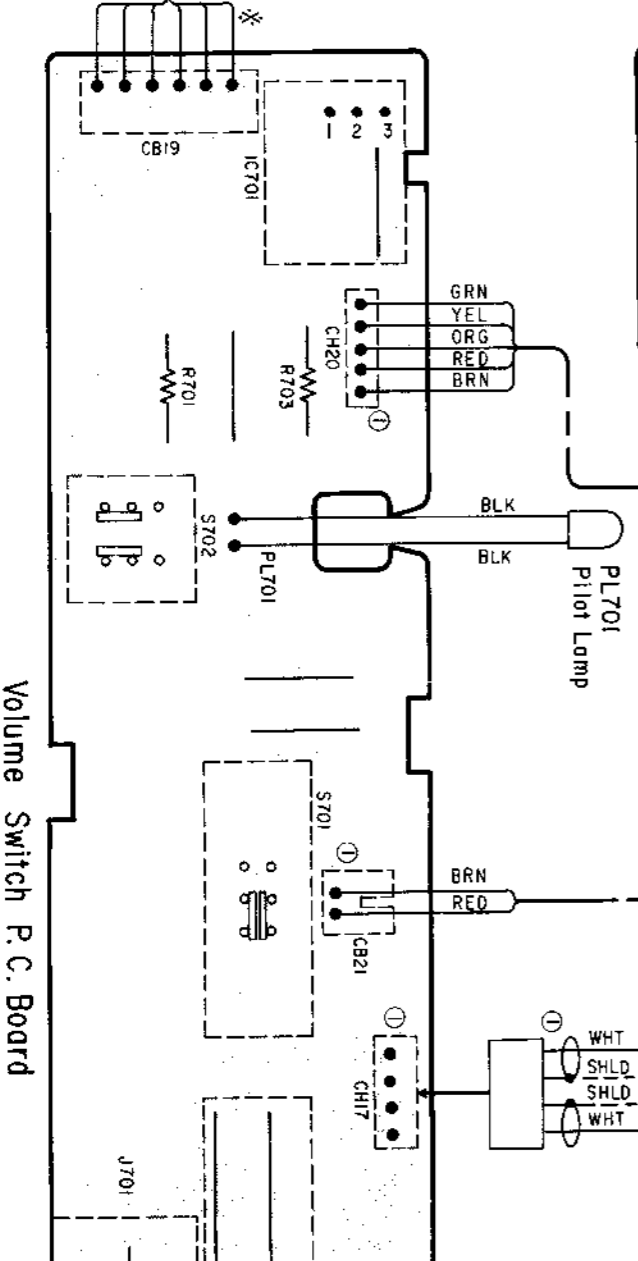
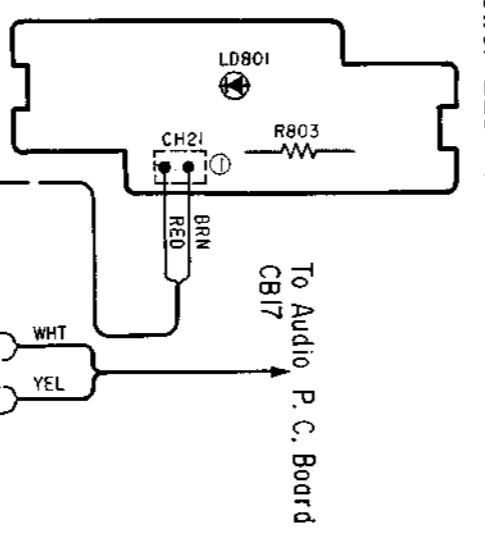

Volume Switch P.C. Board

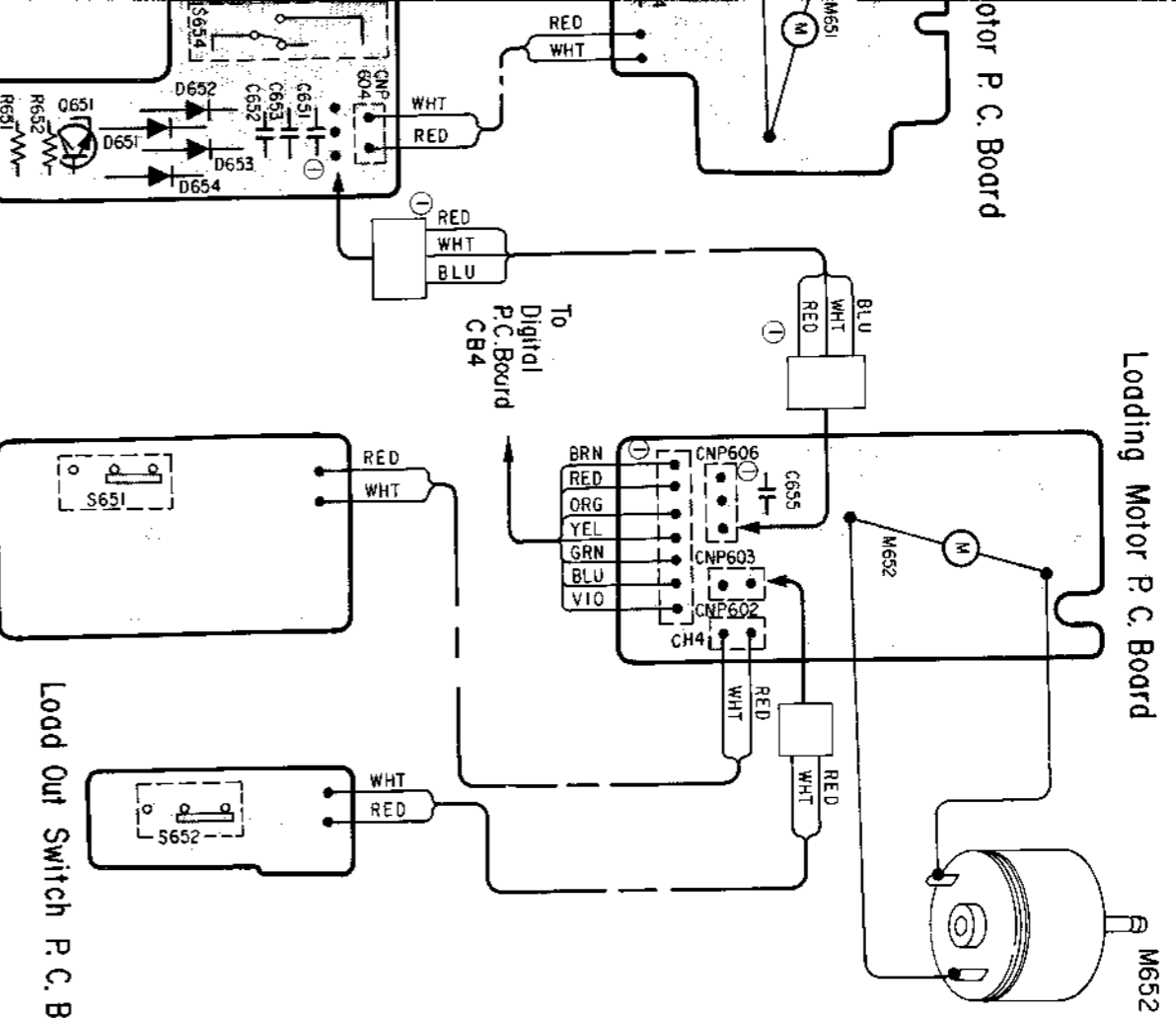

Loading Motor P.C. Board

Switch P.C. Board

Load In Switch P.C. Board

Load Out Switch P.C. Board

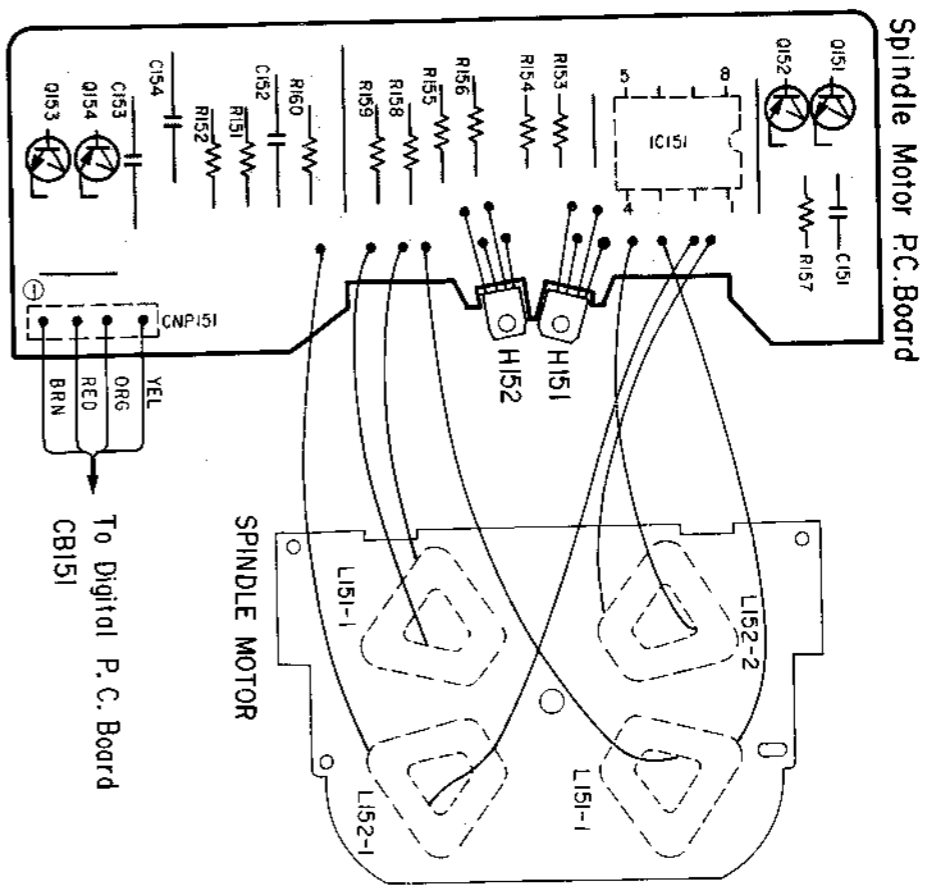

Spindle Motor P.C. Board

To Audio P.C. Board

To Digital P.C. Board

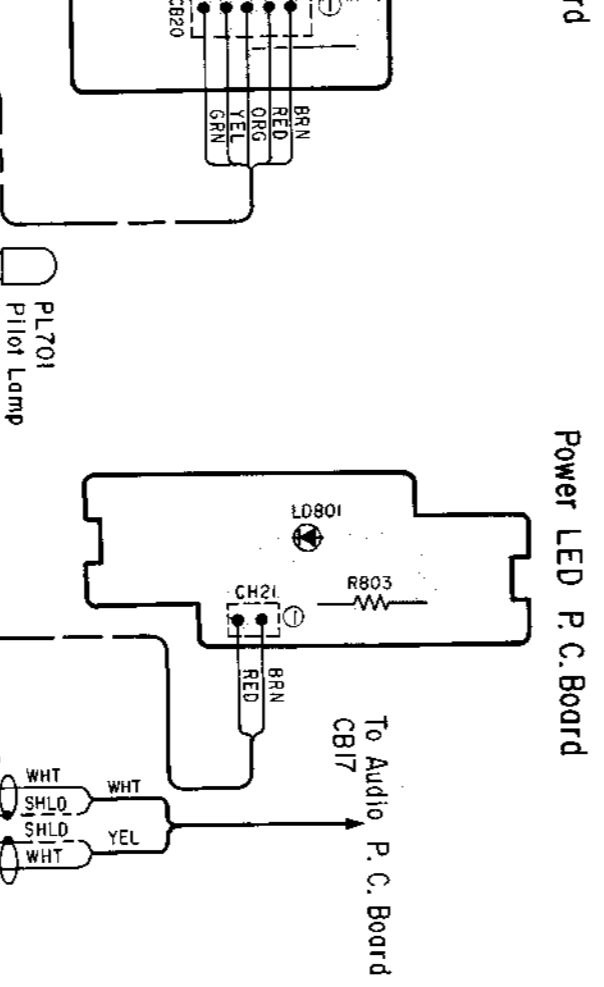

Power LED P.C. Board

To Audio P.C. Board

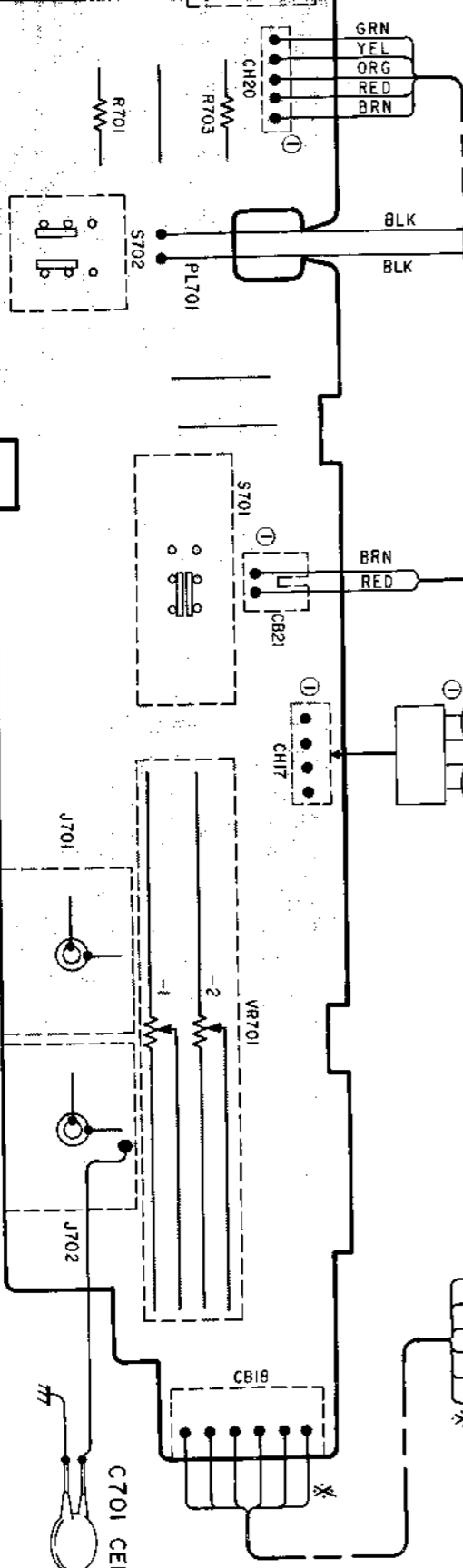

Volume Switch P.C. Board

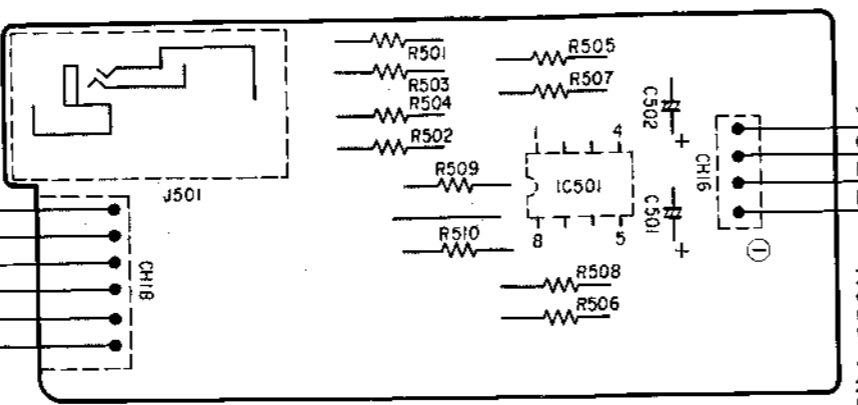

Head Phone P.C. Board

- BLU ..... Blue
- GRN ..... Green
- BLK ..... Black
- GRY ..... Gray
- WHT ..... White
- RED ..... Red
- BRN ..... Brown
- ORG ..... Orange
- YEL ..... Yellow
- VIO ..... Violet
- PNK ..... Pink
- GRN/WHT ..... Green/White
- GRY/WHT ..... Gray/White
- GRY/YEL ..... Gray/Yellow
- GRN/YEL ..... Green/Yellow
- SHLD ..... Shield

# Schematic Diagram (1/2)

IC	IC4101	IC301	IC4203	IC4201	IC4501	IC4301	IC4303		
Transistor (Q)	Q4501 Q4503 Q4505 Q4507 Q4509 Q4511 Q4513 Q4551 Q4553	Q303	Q4502 2SA1015 Q4503 2SC3421 Q4504 2SA1358 Q4505 2SC3421 Q4506 2SA1358 Q4507 2SC3421 Q4508 2SC3421 Q4509 2SC3421 Q4510 2SC3421 Q4511 2SC3421 Q4512 2SC3421 Q4513 2SC3421 Q4514 2SC3421 Q4515 2SC3421 Q4516 2SC3421 Q4517 2SC3421 Q4518 2SC3421 Q4519 2SC3421 Q4520 2SC3421 Q4521 2SC3421 Q4522 2SC3421 Q4523 2SC3421 Q4524 2SC3421 Q4525 2SC3421 Q4526 2SC3421 Q4527 2SC3421 Q4528 2SC3421 Q4529 2SC3421 Q4530 2SC3421 Q4531 2SC3421 Q4532 2SC3421 Q4533 2SC3421 Q4534 2SC3421 Q4535 2SC3421 Q4536 2SC3421 Q4537 2SC3421 Q4538 2SC3421 Q4539 2SC3421 Q4540 2SC3421 Q4541 2SC3421 Q4542 2SC3421 Q4543 2SC3421 Q4544 2SC3421 Q4545 2SC3421 Q4546 2SC3421 Q4547 2SC3421 Q4548 2SC3421 Q4549 2SC3421 Q4550 2SC3421 Q4551 2SC3421 Q4552 2SC3421 Q4553 2SC3421 Q4554 2SC3421 Q4555 2SC3421 Q4556 2SC3421 Q4557 2SC3421 Q4558 2SC3421 Q4559 2SC3421 Q4560 2SC3421	Q301 Q302	Q4601 Q4602 Q4603	Q4601 Q4602 Q4603	Q4601 Q4602 Q4603	Q4601 Q4602 Q4603	Q4601 Q4602 Q4603
Diode (D, LD, ZD)	LD4501 LD4502	ZD4501 ZD4503 ZD4504	ZD4501 ZD4502 ZD4503 ZD4504	D301 LD301 LD302	D4601 D4602 D4603	D4601 D4602 D4603	D4601 D4602 D4603		

## Audio P.C. Board

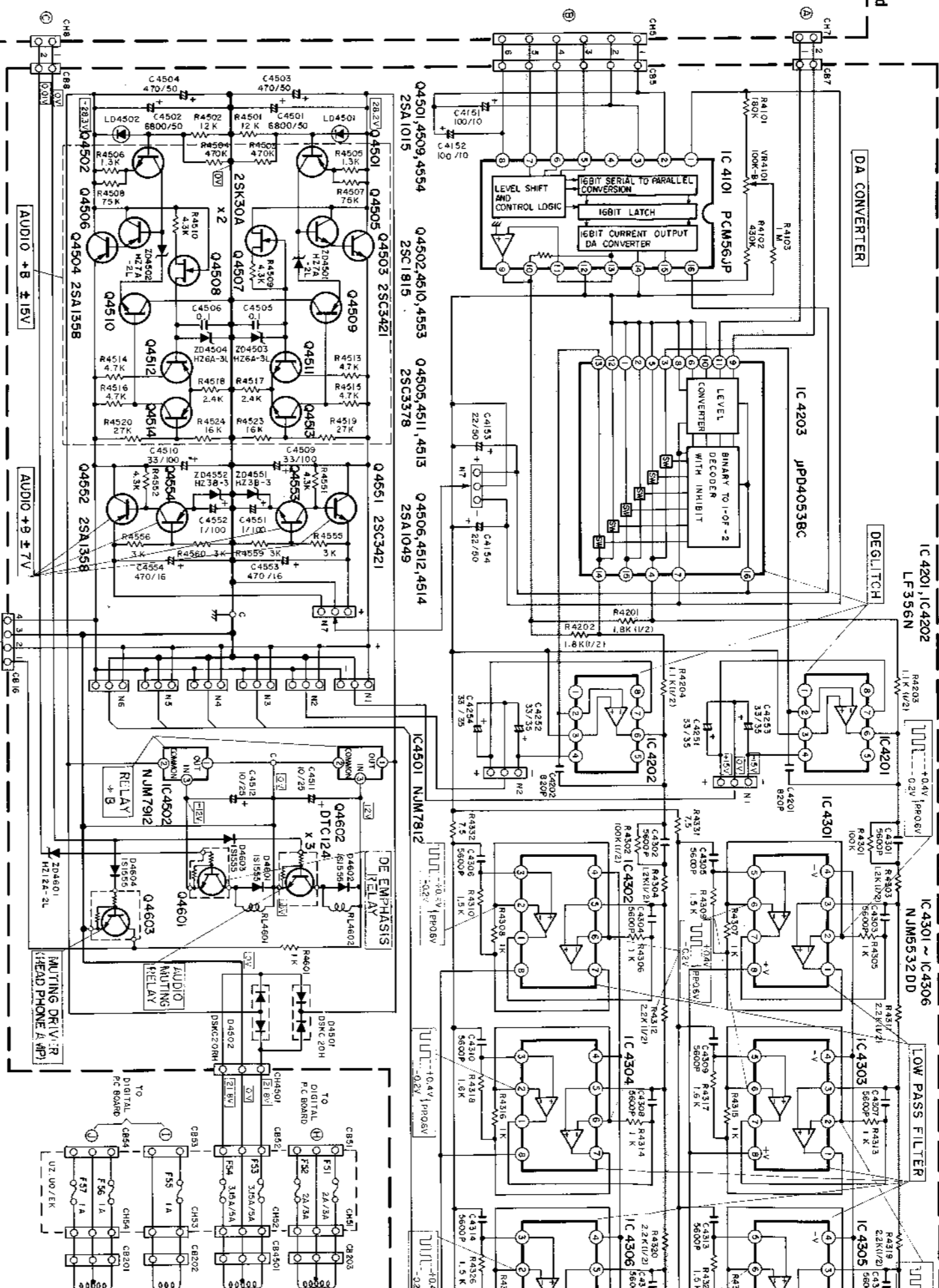

## FL Keyboard P.C. Board

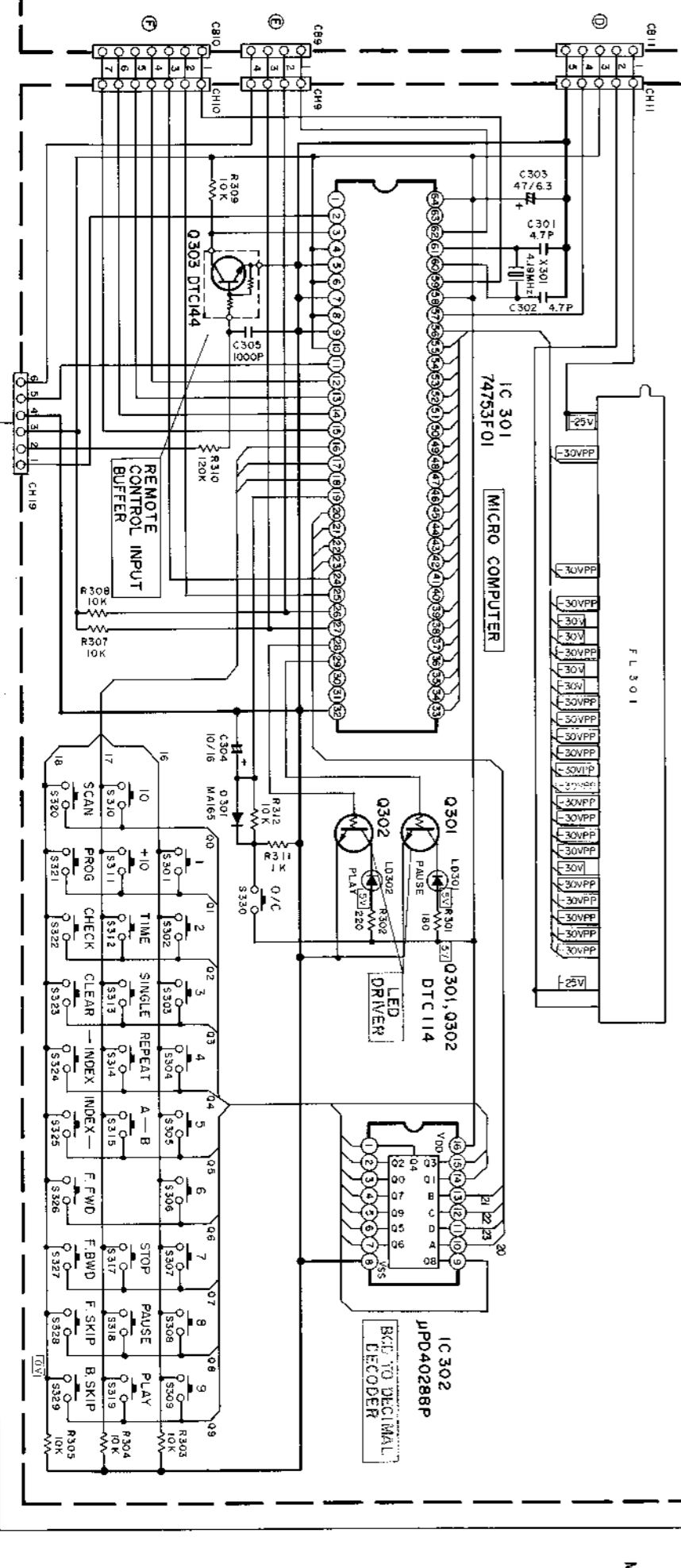

IC4305	IC4401
IC4306	IC4402
	IC501
	IC701
	LB801

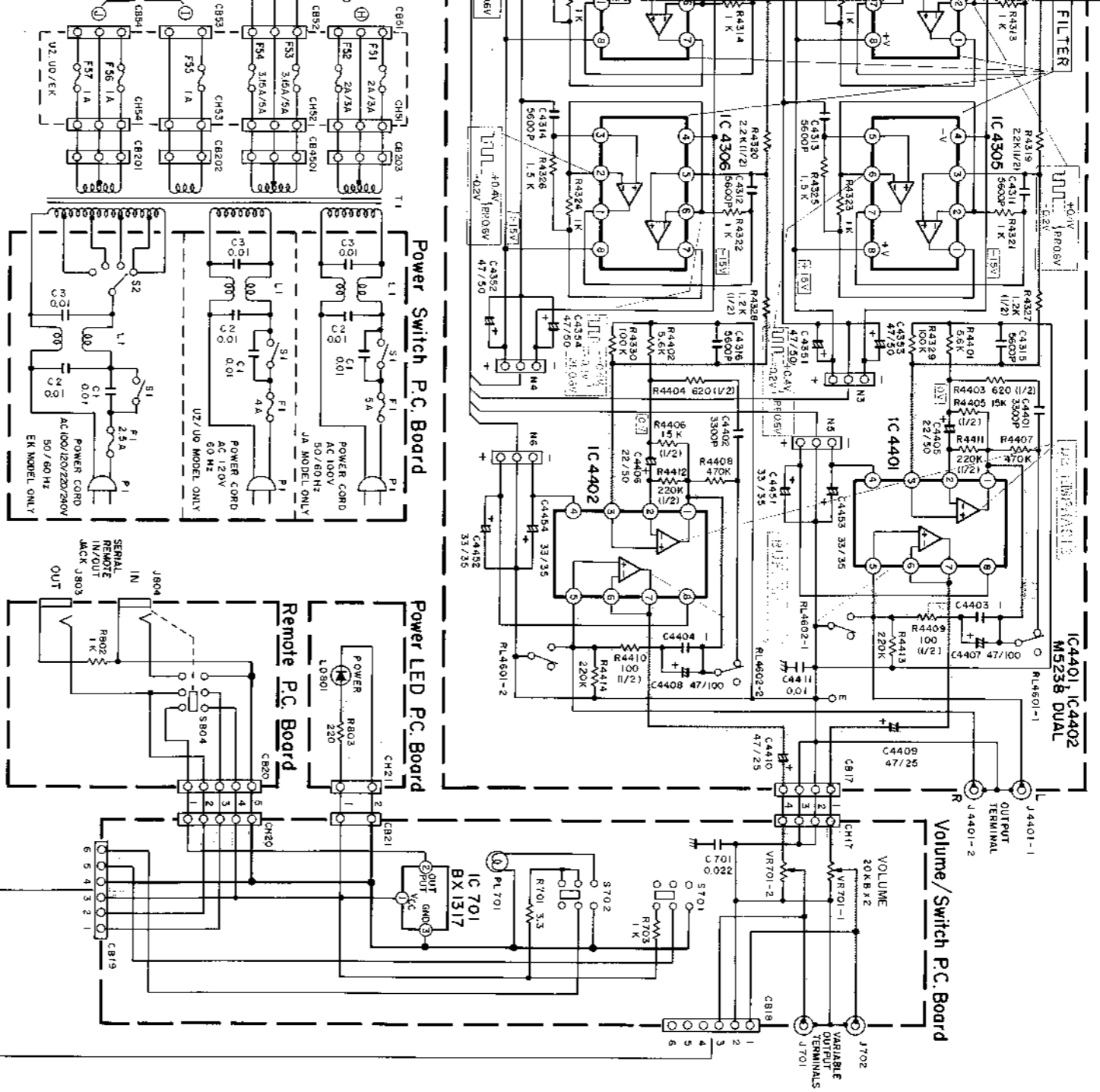

**Measuring Conditions**

1. Power Supply Voltage : AC 100V, 50/60Hz (JA model only)  
: AC 120V, 60Hz (UZ/UQ model only)  
: AC100/120/220/240V  
50Hz/60Hz (EK model only)
2. Measuring Meter : Multi Voltmeter
3. Measuring Point Reference : Between Ground
4. Measuring Condition : No Signal Input  
Deck in play condition

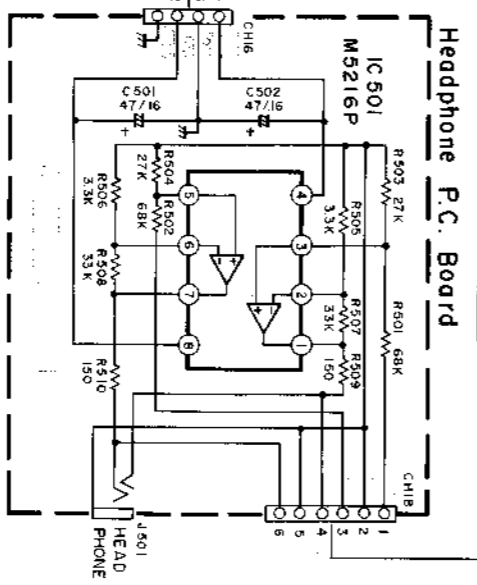

Q601	E	C	B
Q601	-12V	0V	-12V
Q602	0V	12V	0V
Q603	0V	12V	0V
Q651	6.7V	15.2V	7.4V
Q652	-8.7V	-15.2V	-7.4V
Q653	2.7V	7.4V	3.3V
Q654	-2.7V	-7.3V	-3.3V
Q6501	27.1V	16.4V	26.5V
Q6502	-27.2V	-16.4V	-26.7V
Q6504	15.2V	28.2V	15.8V
Q6505	-15.8V	-28.2V	-16.4V
Q6506	-15.8V	-28.3V	-16.4V
Q6509	16.4V	9.9V	9.3V
Q6510	16.4V	9.9V	-9.2V
Q6511	5V	11.3V	5.6V
Q6512	-5V	-11.3V	-5.6V
Q6513	5V	9.3V	5.6V
Q6514	-5V	-9.2V	-5.6V
Q601	0V	3.5V	0V
Q602	0V	3.5V	0V
Q603	0V	0V	0V

IC302	1	2	3	4	5	6	7	8	9	10	11	12	13	14	15	16
IC302	1	2	3	4	5	6	7	8	9	10	11	12	13	14	15	16
0V	5V	0V	5V	0V	5V	0V	5V	0V	5V	0V	5V	0V	5V	0V	5V	0V
0V	5V	0V	5V	0V	5V	0V	5V	0V	5V	0V	5V	0V	5V	0V	5V	0V

IC301	1	2	3	4	5	6	7	8
IC301	1	2	3	4	5	6	7	8
0V	0V	5V	0V	2.4V	2.8V	0V	-5V	
0V	0V	0V	0V	0V	0V	-4.3V	6.7V	

IC4203	1	2	3	4	5	6	7	8
IC4203	1	2	3	4	5	6	7	8
0V	0V	0V	0V	0V	0V	-6.7V	0V	
5V	0V	5V	0V	0V	0V	0V	6.7V	

IC501	1	2	3	4	5	6	7	8
IC501	1	2	3	4	5	6	7	8
0V	0V	0V	-15V	0V	0V	0V	15V	

IC4305	1	2	3	4
IC4305	1	2	3	4
0.08V	PFO.5V	0.08V	-15V	
5	6	7	8	
0.08V	PFO.6V	0.08V	15V	

IC4401	1	2	3	4	5	6	7	8
IC4401	1	2	3	4	5	6	7	8
14V	0V	0V	-15V	0V	0V	15V	14V	

IC4402	1	2	3	4	5	6	7	8
IC4402	1	2	3	4	5	6	7	8
14V	0V	0V	-15V	0V	0V	15V	14V	

IC4306	1	2	3	4	5	6	7	8
IC4306	1	2	3	4	5	6	7	8
0V	0V	PFO.6V	0V	-15V	0V	PFO.6V	0V	
0V	0V	PFO.6V	0V	-15V	0V	PFO.6V	0V	

**NOTES:**

1. All resistance values are in ohms. K = 1,000
2. All capacitance values are in microfarads. P = 1,000,000



# Schematic Diagram (2/2)

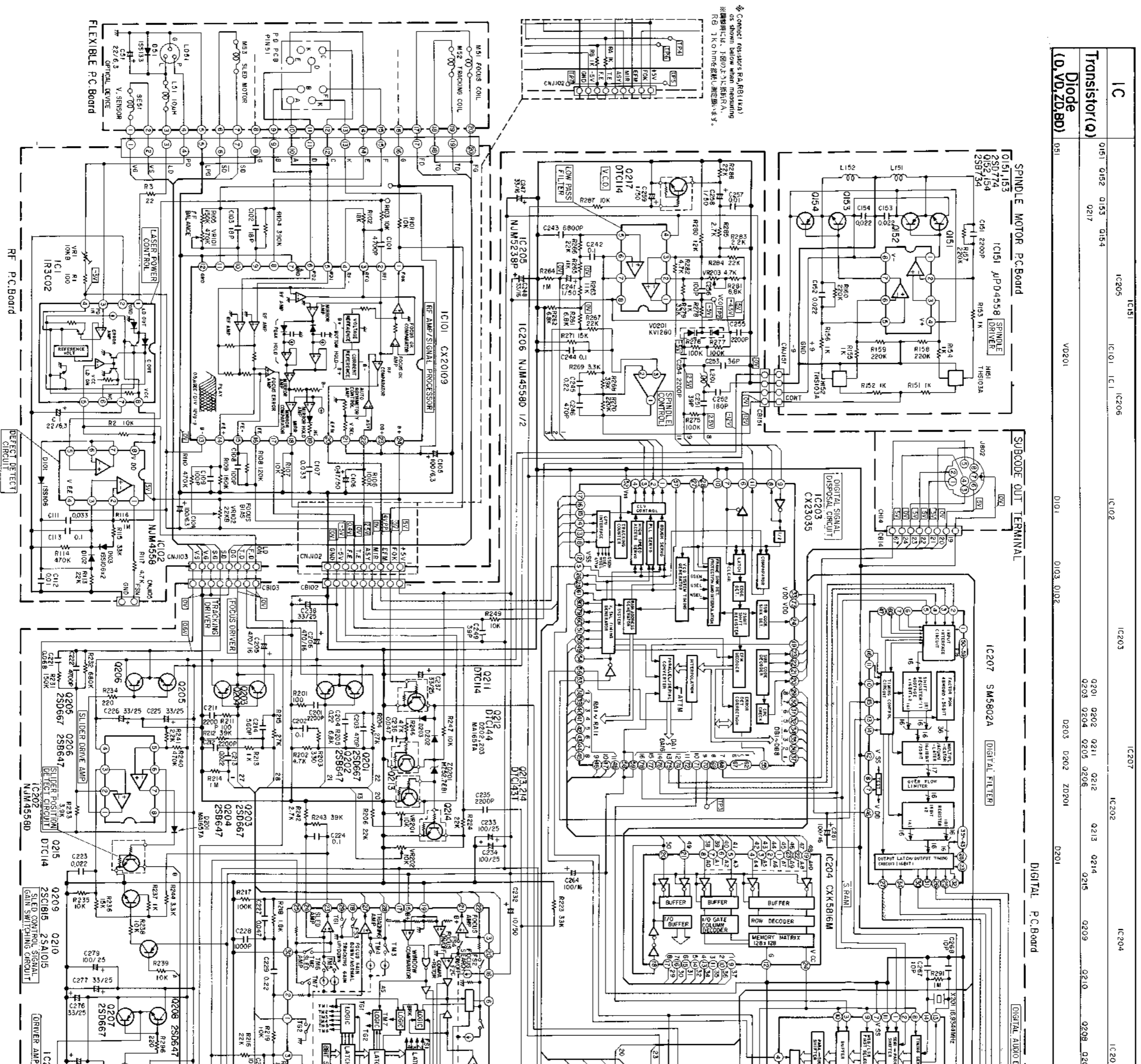

IC	IC151	IC205	IC101	IC1	IC206	IC203	IC207	IC202	IC204	IC201						
Transistor(a)	0151	0152	0153	0154	0217	0201	0202	0211	0212	0213	0214	0215	0209	0210	0208	0207
Diode																
(0 V0, ZD, BD)	051															

\* Connect resistors RA, RB (1/4W) as shown below when measuring.  
 \* 电阻器 RA, RB (1/4W) 的连接如下。  
 RB 1K 欧姆电阻器 (通用型) 连接。



# Electrical Parts List

Resistors: Carbon resistors under ¼ watts are not mentioned in the parts list, please confirm them by schematic diagram.  
 uF = microfarads, pF = picofarads

Symbol No.	Part No.	Description
<b>Power Switch P.C. Board</b>		
<b>Coil</b>		
L1	24T82315F01	FLT. LINE FKOB160MH02
<b>Switch</b>		
S1	40T81906F01	POWER, (SDDL1)
<b>Fuses</b>		
★	F1	65T66926F19 51NM 5A-125V
●	F1	65T66926F03 51NM 4A-125V
■	F1	65T42077U20 Semko 2.5A-120V
▲	F1	65T66926F03 51NM 4A-125V
<b>Capacitors</b>		
	C1	08T57437F09 Ceramic 0.01 μ F
	C2	08T57437F09 Ceramic 0.01 μ F
	C3	08T57437F09 Ceramic 0.01 μ F
<b>Fuse P.C. Board</b>		
<b>Fuses</b>		
●	F51	65T66926F01 51NM 3A-125V
▲	F51	65T66926F01 51NM 3A-125V
■	F51	65T42077U19 Semko 2.0A-150V
●	F52	65T66926F01 51NM 3A-125V
▲	F52	65T66926F01 51NM 3A-125V
■	F52	65T42077U19 Semko 2.0A-150V
●	F53	65T66926F19 51NM 5A-125V
▲	F53	65T66926F19 51NM 5A-125V
■	F53	65T42077U21 Semko 3.15A-100V
●	F54	65T66926F19 51NM 5A-125V
▲	F54	65T66926F19 51NM 5A-125V
■	F54	65T42077U21 Semko 3.15A-100V
●	F55	65T66926F13 51NM 1A-250V
▲	F55	65T66926F13 51NM 1A-250V
■	F55	68T42077U16 Semko 1A-150V

Symbol No.	Part No.	Description
●	F56	65T66926F13 51NM 1A-250V
▲	F56	65T66926F13 51NM 1A-250V
■	F56	68T42077U16 Semko 1A-150V
●	F57	65T66926F13 51NM 1A-250V
▲	F57	65T66926F13 51NM 1A-250V
■	F57	68T42077U16 Semko 1A-150V
<b>Digital P.C. Board</b>		
<b>IC's</b>		
IC201	51T72742F01	CX20108
IC202	51T52383F01	NJM4558D
IC203	51T72739F01	CX23035
IC204	51T80623F01	CXK5816M
or	51T62928F02	μ PD449G
IC205	51T80136F01	M5238P
IC206	51T52383F01	NJM4558D
IC207	51T72743F01	SM5802A
IC208	51T81897F01	CXD1075P
IC210	51T80475F01	TC74HCU04P
IC211	51T80482F01	M6404A-117
IC212	51T64227F01	NJM2903D
IC213	51T80338F01	NJM7805
IC214	51T80339F01	NJM7905
<b>Transistors</b>		
Q201	48T52151F01	2SD667
Q202	48T40339U01	2SB647
Q203	48T52151F01	2SD667
Q204	48T40339U01	2SB647
Q205	48T52151F01	2SD667
Q206	48T40339U01	2SB647
Q207	48T52151F01	2SD667
Q208	48T40339U01	2SB647
Q209	48T81101F01	2SC1815
Q210	48T81102F01	2SA1015
Q211	48T62963F02	DTC114
Q212	48T62963F04	DTC144
Q213	48T62963F09	DTC143T
Q214	48T62963F09	DTC143T
Q215	48T62963F02	DTC114

Note: ● : For North American model only(UZ), ▲ : For Canadian model only(UQ)  
 ■ : For General Foreign model only(EK), ★ : For Japanese model only(JA)  
 Others : Common

Symbol No.	Part No.	Description
Q216	48T62963F02	DTC114
Q217	48T62963F02	DTC114
Q218	48T56030F01	2SB941
<b>Diodes</b>		
D201	48T44813F01	MA165TA
D202	48T44813F01	MA165TA
D203	48T44813F01	MA165TA
D204	48T44813F01	MA165TA
D205	48T44813F01	MA165TA
D206	48T44813F01	MA165TA
D207	48T44813F01	MA165TA
BD201	48T53388F01	Bridge S1VB
BD202	48T62282F01	Bridge UB152
VD201	48T72759F01	Varactor KV1260
ZD201	48T68697F01	Zener HZS2.7EB1
ZD202	48T68697F17	Zener HZS5.1EB1
ZD203	48T68697F82	Zener HZS33EB3
ZD204	48T68697F71	Zener HZS24EB4
ZD205	48T68697F17	Zener HZS5.1EB1
ZD206	48T68697F03	Zener HZS3.0EB1
<b>Coils</b>		
L201	24T72767F01	Inductor 7 $\mu$ H (BLK)
L202	24T50508F22	Inductor 10 $\mu$ H
<b>Crystals</b>		
X201 or X202	48T80473F01 48T80474F01 91T60592F02	16.9344MHz NDK 16.9344MHz KSS Ceramic LOCK CSA4.19MHz
<b>Capacitors</b>		
C201	08T57705F59	Mylar 2200pF
C202	08T57705F79	Mylar 0.1 $\mu$ F
C203	08T55260F45	Ceramic 470pF
C204	08T57705F83	Mylar 0.22 $\mu$ F
C205	23T00136L32	Electrolytic 470 $\mu$ F/16V

Symbol No.	Part No.	Description
C206	23T00136L32	Electrolytic 470 $\mu$ F/16V
C211	08T57705F59	Mylar 2200pF
C212	08T57705F59	Mylar 2200pF
C213	08T57705F71	Mylar 0.022 $\mu$ F
C214	08T55260F46	Ceramic 560pF
C221	08T57705F77	Mylar 0.068 $\mu$ F
C222	08T55260F58	Ceramic 4700pF
C223	08T57705F71	Mylar 0.022 $\mu$ F
C224	08T57705F79	Mylar 0.1 $\mu$ F
C225	23T00138L29	Electrolytic 33 $\mu$ F/25V
C226	23T00138L29	Electrolytic 33 $\mu$ F/25V
C227	08T57705F75	Mylar 0.047 $\mu$ F
C228	08T57705F55	Mylar 1000pF
C229	08T57705F83	Mylar 0.22 $\mu$ F
C230	08T55260F49	Ceramic 1000pF
C231	08T57705F73	Mylar 0.033 $\mu$ F
C232	23T00138L49	Electrolytic 10 $\mu$ F/50V
C233	23T00138L31	Electrolytic 100 $\mu$ F/25V
C234	23T00138L31	Electrolytic 100 $\mu$ F/25V
C235	08T57705F59	Mylar 2200pF
C236	08T57705F75	Mylar 0.047 $\mu$ F
C237	23T00138L29	Electrolytic 33 $\mu$ F/25V
C238	23T00138L29	Electrolytic 33 $\mu$ F/25V
C239	08T57705F67	Mylar 0.01 $\mu$ F
C241	23T00138L45	Electrolytic 1 $\mu$ F/50V
C242	08T57705F79	Mylar 0.1 $\mu$ F
C243	08T57705F65	Mylar 6800pF
C244	08T57705F79	Mylar 0.1 $\mu$ F
C245	08T57705F83	Mylar 0.22 $\mu$ F
C246	08T55260F45	Ceramic 470pF
C247	23T00138L19	Electrolytic 33 $\mu$ F/16V
C248	23T00138L19	Electrolytic 33 $\mu$ F/16V
C249	08T55260F27	Ceramic 39pF
C251	21S40655F18	Ceramic 39pF
C252	21S40655F26	Ceramic 180pF
C253	08T61939F24	Ceramic 36pF
C254	08T55260F54	Ceramic 2200pF
C255	08T55260F54	Ceramic 2200pF
C256	08T55260F37	Ceramic 100pF
C257	08T57705F67	Mylar 0.01 $\mu$ F
C258	23T00138L49	Electrolytic 10 $\mu$ F/50V
C259	23T00138L45	Electrolytic 1 $\mu$ F/50V
C261	23T00138L21	Electrolytic 100 $\mu$ F/16V
C262	23T00138L21	Electrolytic 100 $\mu$ F/16V
C263	23T00160L35	Electrolytic 1000 $\mu$ F/16V

Note : When replacing varactor diode VD201 always use one with the same rank.

Symbol No.	Part No.	Description
C264	23T00138L21	Electrolytic 100 $\mu$ F / 16V
C265	23T00138L21	Electrolytic 100 $\mu$ F / 16V
C266	08T55260F13	Ceramic 10pF
C267	08T55260F13	Ceramic 10pF
C268	08T55260F21	Ceramic 22pF
C269	08T55260F21	Ceramic 22pF
C271	08T57705F67	Mylar 0.01 $\mu$ F
C272	23T00138L29	Electrolytic 33 $\mu$ F / 25V
C273	08T57705F71	Mylar 0.022 $\mu$ F
C274	08T55260F49	Ceramic 1000pF
C275	08T55260F49	Ceramic 1000pF
C276	23T00138L29	Electrolytic 33 $\mu$ F / 25V
C277	23T00138L29	Electrolytic 33 $\mu$ F / 25V
C278	23T00138L31	Electrolytic 100 $\mu$ F / 25V
C279	23T00138L31	Electrolytic 100 $\mu$ F / 25V
C281	23T00134L83	Electrolytic 220 $\mu$ F / 63V
C282	23T00138L52	Electrolytic 47 $\mu$ F / 50V
C283	23T00136L68	Electrolytic 100 $\mu$ F / 50V
C284	23T00138L39	Electrolytic 47 $\mu$ F / 35V
C285	23T00138L28	Electrolytic 22 $\mu$ F / 25V
C286	23T00138L48	Electrolytic 4.7 $\mu$ F / 50V
C287	23T83421F02	Electrolytic 4700 $\mu$ F / 25V
C288	23T83421F03	Electrolytic 3300 $\mu$ F / 25V
C289	23T00136L47	Electrolytic 2200 $\mu$ F / 25V
C290	23T00136L46	Electrolytic 1000 $\mu$ F / 25V
C291	08T57705F79	Mylar 0.1 $\mu$ F
C292	08T82245F01	Mylar 0.01 $\mu$ F
C293	23T00138L21	Electrolytic 100 $\mu$ F / 16V
C294	08S40805F19	Ceramic 0.01 $\mu$ F
<b>Resistors</b>		
VR201	18B44064J03	Variable 10K ohm
VR202	18B44064J03	Variable 10K ohm
VR203	18B44064J02	Variable 4.7K ohm
<b>FL Keyboard P.C. Board</b>		
<b>IC's</b>		
IC301	51T74753F01	74753F01
IC302	51T51507F01	$\mu$ PD4028BP

Symbol No.	Part No.	Description
<b>Transistors</b>		
Q301	48T62963F02	DTC114
Q302	48T62963F02	DTC114
Q303	48T62963F10	DTC114
<b>Diodes / LED's</b>		
D301	48T44813F02	Diode, MA165
LD301	48T60947F07	SLH-34DU3F (ORG) (PAUSE)
LD302	48T60947F05	SLH-34VR3F (RED) (PLAY)
<b>Switches</b>		
S301	40T80315F01	TACT SKHHQF (1)
S302	40T80315F01	TACT SKHHQF (2)
S303	40T80315F01	TACT SKHHQF (3)
S304	40T80315F01	TACT SKHHQF (4)
S305	40T80315F01	TACT SKHHQF (5)
S306	40T80315F01	TACT SKHHQF (6)
S307	40T80315F01	TACT SKHHQF (7)
S308	40T80315F01	TACT SKHHQF (8)
S309	40T80315F01	TACT SKHHQF (9)
S310	40T80315F01	TACT SKHHQF (10)
S311	40T80315F01	TACT SKHHQF (+10)
S312	40T80315F01	TACT SKHHQF (TIME)
S313	40T80315F01	TACT SKHHQF (SINGLE)
S314	40T80315F01	TACT SKHHQF (REPEAT)
S315	40T80315F01	TACT SKHHQF (A $\rightarrow$ B)
S317	40T80315F01	TACT SKHHQF (STOP)
S318	40T80315F01	TACT SKHHQF (PAUSE)
S319	40T80315F01	TACT SKHHQF (PLAY)
S320	40T80315F01	TACT SKHHQF (SCAN)
S321	40T80315F01	TACT SKHHQF (PROG)
S322	40T80315F01	TACT SKHHQF (CHECK)
S323	40T80315F01	TACT SKHHQF (CLEAR)
S324	40T80315F01	TACT SKHHQF ( $\leftarrow$ INDEX)
S325	40T80315F01	TACT SKHHQF (INDEX $\rightarrow$ )
S326	40T80315F01	TACT SKHHQF (F.FWD)
S327	40T80315F01	TACT SKHHQF (F.BWD)
S328	40T80315F01	TACT SKHHQF (F.SKIP)
S329	40T80315F01	TACT SKHHQF (B-SKIP)
S330	40T80315F01	TACT SKHHQF (O/C)

Symbol No.	Part No.	Description
<b>Crystal</b>		
X301	91T60592F02	Ceramic LOCK 4.19MHz
<b>FL Tube</b>		
FL301	65T80320F01	CD-DISPLAY
<b>Capacitors</b>		
C301	08S40154T09	Ceramic 4.7pF
C302	08S40154T09	Ceramic 4.7pF
C303	23S57422F14	Electrolytic 47 $\mu$ F/6.3V
C304	23T43247F09	Electrolytic 10 $\mu$ F/16V
C305	21C45322G28	Ceramic 1000pF
<b>Volume/Switch P.C. Board</b>		
<b>IC</b>		
IC701	51T80330F01	BX1317
<b>Switches</b>		
S701	40T80313F01	SLID SSSYO 2-2-6 (Timer Play)
S702	40T80314F01	PUSH SPEA 2-2 NS (DIGITAL OUT)
<b>Lamp</b>		
PL701	65T80326F01	5V-150mA
<b>Jacks</b>		
J701	09T80329F01	PLATE PHONO T-6025F (Front Output L)
J702	09T80329F01	PLATE PHONO T-6025F (Front Output R)
<b>Rsesistor</b>		
VR701	18T80316F01	Volume SLIDE RSGA2 20K ohm-B

Symbol No.	Part No.	Description
<b>Audio P.C. Board</b>		
<b>IC's</b>		
IC4101	51T80318F01	PCM56JP
IC4201	51T58508F01	LF356N
IC4202	51T58508F01	LF356N
IC4203	51T67480F01	$\mu$ PD4053BC
IC4301	51T74544F01	NJM 5532DD
IC4302	51T74544F01	NJM 5532DD
IC4303	51T74544F01	NJM 5532DD
IC4304	51T74544F01	NJM 5532DD
IC4305	51T74544F01	NJM 5532DD
IC4306	51T74544F01	NJM 5532DD
IC4401	51T80136F01	M5238P
IC4402	51T80136F01	M5238P
IC4501	51T80340F01	NJM7812
IC4502	51T80341F01	NJM7912
<b>Transistors</b>		
Q4501	48T51118F02	2SA1015
Q4502	48S43525F02	2SC1815
Q4503	48T69176F02	2SC3421
Q4504	48T69177F02	2SA1358
Q4505	48T80986F01	2SC3378
Q4506	48T71760F01	2SA1049
Q4507	48T52152F01	FET 2SK30A
Q4508	48T52152F01	FET 2SK30A
Q4509	48T51118F02	2SA1015
Q4510	48S43525F02	2SC1815
Q4511	48T80986F01	2SC3378
Q4512	48T71760F01	2SA1049
Q4513	48T80986F01	2SC3378
Q4514	48T71760F01	2SA1049
Q4551	48T69176F02	2SC3421
Q4552	48T69177F02	2SA1358
Q4553	48S43525F02	2SC1815
Q4554	48T51118F02	2SA1015
Q4601	48T62965F03	DTC124
Q4602	48T62965F03	DTC124
Q4603	48T62965F03	DTC124

Symbol No.	Part No.	Description
<b>Diodes/LEDs</b>		
D4501	48T80317F01	TWIN D5KC20H
D4502	48T80317F02	TWIN D5KC20RH
D4601	48T43189F01	1S1555
D4602	48T43189F01	1S1555
D4603	48T43189F01	1S1555
D4604	48T43189F01	1S1555
LD4501	48T62493F01	LED AA3422K (ORG)
LD4502	48T62493F01	LED AA3422K (ORG)
ZD4501	48T52741F11	Zener HZ7A-2L
ZD4502	48T52741F11	Zener HZ7A-2L
ZD4503	48T52741F03	Zener HZ6A-3L
ZD4504	48T52741F03	Zener HZ6A-3L
ZD4551	48T52739F12	Zener HZ 3B-3
ZD4552	48T52739F12	Zener HZ 3B-3
ZD4601	48T52741F38	Zener HZ12A-2L
<b>Relays</b>		
RL4601	80T68404F01	G5A
RL4602	80T73804F02	FBR42NG012-P
<b>Jack</b>		
J4401	09T80321F01	Plate, Phone 2P T5882
<b>Capacitors</b>		
C4151	23T00138L12	Electrolytic 100 $\mu$ F/10V
C4152	23T00138L12	Electrolytic 100 $\mu$ F/10V
C4153	23T00138L50	Electrolytic 22 $\mu$ F/50V
C4154	23T00138L50	Electrolytic 22 $\mu$ F/50V
C4201	08T61630F40	Polyethylene 820pF
C4202	08T61630F40	Polyethylene 820pF
C4251	23T00138L38	Electrolytic 33 $\mu$ F/35V
C4252	23T00138L38	Electrolytic 33 $\mu$ F/35V
C4253	23T00138L38	Electrolytic 33 $\mu$ F/35V
C4254	23T00138L38	Electrolytic 33 $\mu$ F/35V
C4301	08T61630F60	Polyethylene 5600pF
C4302	08T61630F60	Polyethylene 5600pF
C4303	08T00151L22	Polypropylene 5600pF
C4304	08T00151L22	Polypropylene 5600pF
C4305	08T00151L22	Polypropylene 5600pF

Symbol No.	Part No.	Description
C4306	08T00151L22	Polypropylene 5600pF
C4307	08T00151L22	Polypropylene 5600pF
C4308	08T00151L22	Polypropylene 5600pF
C4309	08T00151L22	Polypropylene 5600pF
C4310	08T00151L22	Polypropylene 5600pF
C4311	08T00151L22	Polypropylene 5600pF
C4312	08T00151L22	Polypropylene 5600pF
C4313	08T00151L22	Polypropylene 5600pF
C4314	08T00151L22	Polyethylene 5600pF
C4315	08T61630F60	Polyethylene 5600pF
C4316	08T61630F60	Polypropylene 5600pF
C4351	23T00138L52	Electrolytic 47 $\mu$ F/50V
C4352	23T00138L52	Electrolytic 47 $\mu$ F/50V
C4353	23T00138L52	Electrolytic 47 $\mu$ F/50V
C4354	23T00138L52	Electrolytic 47 $\mu$ F/50V
C4401	08T61630F54	Polyethylene 3300pF
C4402	08T61630F54	Polyethylene 3300pF
C4403	08T00019L06	Metalized 1 $\mu$ F
C4404	08T00019L06	Metalized 1 $\mu$ F
C4405	23T00132L23	Electrolytic 22 $\mu$ F/50V
C4406	23T00132L23	Electrolytic 22 $\mu$ F/50V
C4407	23T80998F87	Electrolytic 47 $\mu$ F/100V
C4408	23T80998F87	Electrolytic 47 $\mu$ F/100V
C4409	23T00138L30	Electrolytic 47 $\mu$ F/25V
C4410	23T00138L30	Electrolytic 47 $\mu$ F/25V
C4411	08S40805F19	Ceramic 0.01 $\mu$ F
C4451	23T00138L38	Electrolytic 33 $\mu$ F/35V
C4452	23T00138L38	Electrolytic 33 $\mu$ F/35V
C4453	23T00138L38	Electrolytic 33 $\mu$ F/35V
C4454	23T00138L38	Electrolytic 33 $\mu$ F/35V
C4501	23T83421F01	Electrolytic 6800 $\mu$ F/50V
C4502	23T83421F01	Electrolytic 6800 $\mu$ F/50V
C4503	23T00132L31	Electrolytic 470 $\mu$ F/50V
C4504	23T00132L31	Electrolytic 470 $\mu$ F/50V
C4505	08T57705F79	Mylar 0.1 $\mu$ F
C4506	08T57705F79	Mylar 0.1 $\mu$ F
C4509	23T00138L78	Electrolytic 33 $\mu$ F/100V
C4510	23T00138L78	Electrolytic 33 $\mu$ F/100V
C4511	23T00138L27	Electrolytic 10 $\mu$ F/25V
C4512	23T00138L27	Electrolytic 10 $\mu$ F/25V
C4551	23T00138L72	Electrolytic 1 $\mu$ F/100V
C4552	23T00138L72	Electrolytic 1 $\mu$ F/100V
C4553	23T00138L24	Electrolytic 470 $\mu$ F/16V
C4554	23T00138L24	Electrolytic 470 $\mu$ F/16V

Symbol No.	Part No.	Description
<b>Resistors</b> (All resistors are carbon film 1/2W±5% unless otherwise noted.)		
R4201	06T00147L71	1.8K ohm
R4202	06T00147L71	1.8K ohm
R4203	06T00147L66	1.1K ohm
R4204	06T00147L66	1.1K ohm
R4303	06T00147L67	1.2K ohm
R4304	06T00147L67	1.2K ohm
R4311	06T00147L73	2.2K ohm
R4312	06T00147L73	2.2K ohm
R4319	06T00147L73	2.2K ohm
R4320	06T00147L73	2.2K ohm
R4327	06T00147L67	1.2K ohm
R4328	06T00147L67	1.2K ohm
R4401	06T00147L83	5.6K ohm
R4402	06T00147L83	5.6K ohm
R4403	06T00147L60	620 ohm
R4404	06T00147L60	620 ohm
R4405	06T00147L93	15K ohm
R4406	06T00147L93	15K ohm
R4409	06T00147L41	100 ohm
R4410	06T00147L41	100 ohm
VR4101	18B44064J07	Variable 100K ohm
<b>Flex P.C. Board</b>		
<b>Diode/Inductor</b>		
D51	48T51267F01	Diode, 1SS133
L51	24E02910S01	Micro
<b>Motors/Capacitor</b>		
M51	23E03017S01	Coil, Focus
M52		Coil, Tracking
C51		Capacitor, Tantalum Chip 2.2 μ F
<b>RF P.C. Board</b>		
<b>IC's</b>		
IC1	51E02747S01	IR3C02AN
IC101	51T72750F01	CX20109
IC102	51E01329S01	NJM 4558M

Symbol No.	Part No.	Description
<b>Diodes</b>		
D101		1SS106
D102		1SS106
D103		1SS106
<b>Capacitors</b>		
C1	23E03310S01	Electrolytic 22 μ F/6.3V
C101	21E03020S01	4700pF
C102		Ceramic 18pF/50V
C103		Ceramic 18pF/50V
C104	23E03016S02	Tantalum 100 μ F/6.3V
C105	23E03016S02	Tantalum 100 μ F/6.3V
C106	23E03309S01	Electrolytic 0.47 μ F
C107	08E03018S01	Film 0.033 μ F/50V
C108	21E03313S01	Ceramic 100pF/50V
C109	21E03313S01	Ceramic 100pF/50V
C111	08E03018S01	Film 0.033 μ F/50V
C112	08E03311S01	Film 0.01 μ F
C113	08E03019S01	Film 0.1 μ F/50V
<b>Resistors</b>		
VR1	18E02721S01	Variable 10K ohm
VR101	18E02723S01	Variable 470K ohm
VR102	18E02722S01	Variable 22K ohm
<b>Spindle Motor P.C. Board</b>		
<b>IC's/Transistors</b>		
IC151	51S43471U02	IC, UPC 4558
Q151	48E02745S01	2SD774
Q152	48E02745S01	2SB734
Q153		2SD774
Q154		2SB734
<b>Thyristors/Capacitors</b>		
H151	48E02748S01	Thyristor103A-1
H152	48E02748S01	Thyristor103A-1
C151	21E03021S01	Ceramic 2200pF/50V
C152	21E03021S01	Ceramic 2200pF/50V
C153	08E03022S01	0.022 μ F/25V
C154	08E03022S01	0.022 μ F/25V



Symbol No.	Part No.	Description
<b>L/C Switch P.C. Board</b>		
<b>Transistor/Diodes</b>		
Q651	48E02745S01	Transistor 2SD774
D651	48C40235G02	10E2
D652	48C40235G02	10E2
D653	48C40235G02	10E2
D654	48C40235G02	10E2
<b>Capacitors</b>		
C651	08E03312S01	Film 0.022 $\mu$ F/50V
C652	08E03312S01	Film 0.022 $\mu$ F/50V
C653	08E03312S01	Film 0.022 $\mu$ F/50V
<b>Chuckling Motor P.C. Board</b>		
<b>Capacitor</b>		
C654	23E03015S01	Electrolytic 4700pF
<b>Loading Motor P.C. Board</b>		
<b>Capacitor</b>		
C655	23E03015S01	Electrolytic 4700pF
<b>Head Phone P.C. Board</b>		
<b>IC/Jack</b>		
IC501	51T81896F01	IC, M5216P
J501	09T56010F02	Head Phone M1669
<b>Capacitors</b>		
C501	23T00138L20	Electrolytic 47 $\mu$ F/16V
C502	23T00138L20	Electrolytic 47 $\mu$ F/16V
<b>Miscellaneous</b>		
BU-1C	88E02720S01	Optical Pick-up Block
C701	21C45322G32	Capacitor, Ceramic 0.022 $\mu$ F
J801	09T80333F01	Jack, Plate, Phono
J802	09T80324F01	Jack, Din Subcord
J803	09T80323F01	Jack, REMOTE HSJ0862 (REMOTE OUT)

Symbol No.	Part No.	Description
J804	09T80322F01	Jack, REMOTE HSJ0864 (REMOTE IN)
S804		
LD801	48T60947F05	LED, SLH-34VR3F (RED) (POWER)
M53	25E03506S01	Sled Coil
M651	59E03353S01	Chuckling Motor Assembly
M652	59E02712S01	Loading Motor Assembly
★ P1	28T81592F01	Plug, AC Cord
● P1	28T55335F02	Plug, AC Cord
■ P1	28T43812P01	Plug, AC Cord
▲ P1	28T55335F02	Plug, AC Cord
■ S2	40T80258F01	Switch, Voltage Select (4C)
S651	40E03354S01	Push Switch (LOAD IN)
S652	40E03354S01	Push Switch (LOAD OUT)
S653	40E03355S01	Micro Switch (MOTOR ON/OFF)
S654	40E02729S01	Micro Switch (CHUCKING)
SE51	25E03505S01	Sensor Coil
★ T1	25T80325F01	Transformer, Power
● T1	25T81966F01	Transformer, Power
■ T1	25T81967F01	Transformer, Power
▲ T1	25T81966F01	Transformer, Power
T801	25T80344F01	Transformer, Pulse

Note: ● : For North American model only(UZ), ▲ : For Canadian model only(UQ)  
 ■ : For General Foreign model only(EK), ★ : For Japanese model only(JA)  
 Others : Common

## Parts List by the Destination

Symbol No.	Description	POWER SOURCE			
		JA★ 100V	UZ● 120V	UQ▲ 120V	EK■ 220V
		Japan	North America	Canada	General Foreign
F1	Fuse	65T66926F19	65T66926F03	65T66926F03	65T42077U20
F51	Fuse	Not Used	65T66926F01	65T66926F01	65T42077U19
F52	Fuse	Not Used	65T66926F01	65T66926F01	65T42077U19
F53	Fuse	Not Used	65T66926F19	65T66926F19	65T42077U21
F54	Fuse	Not Used	65T66926F19	65T66926F19	65T42077U21
F55	Fuse	Not Used	65T66926F13	65T66926F13	65T42077U16
F56	Fuse	Not Used	65T66926F13	65T66926F13	65T42077U16
F57	Fuse	Not Used	65T66926F13	65T66926F13	65T42077U16
P1	Plug, AC Cord	28T81592F01	28T55335F02	28T55335F02	28T43812P01
S2	Switch	Not Used	Not Used	Not Used	40T80258F01
T1	Transformer, Power	25T80325F01	25T81966F01	25T81966F01	25T81967F01
1	Panel, Front	64D80159F01	64D80159F02	64D80159F02	64D80159F02
5	Cover, Rear	15D80186F01	15D80186F02	15D80186F02	15D80186F03
38	Stopper, Cord	43B41625J05	43B41625J02	43B41625J02	43B41625J02
78	Label, Fuse	Not Used	54B62266F11	54B62266F11	54B62266F02
83	Label, Fuse	Not Used	54B62266F10	54B62266F10	Not Used
84	Label, Fuse	Not Used	54B62266F12	54B62266F12	Not Used
85	Label, Fuse	Not Used	54B62266F28	54B62266F28	Not Used
87	Screw	Not Used	Not Used	03D40014G04	Not Used
101-1	Owners Manual	68P80130F21	68P81707F30	68P81707F33	68P81707F33
105	Unit, Remote Control	01T80478F01	01T80478F02	01T80478F02	01T80478F02
108	Carton, Packing	56S71001F68	56S71001F81	56S71001F81	56S71001F81

## Packing Method View

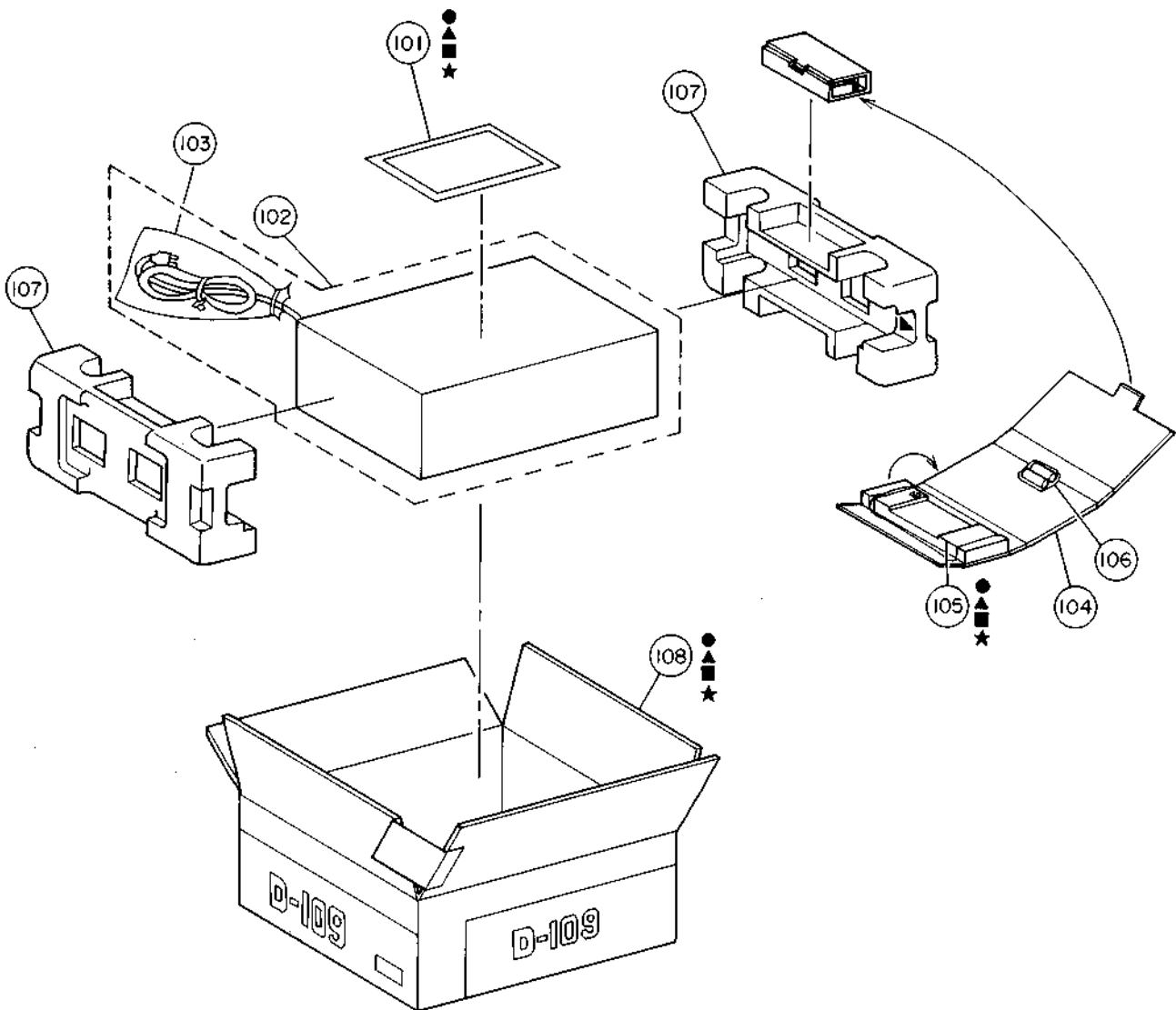

## Packing Assembly Parts List

Symbol No.	Part No.	Description
★ 101-1	68P80130F21	Owners Manual
▲ 101-1	68P81707F33	Owners Manual
■ 101-1	68P81707F33	Owners Manual
● 101-1	68P81707F30	Owners Manual
101-2	28P58909F01	Plug, Audio Cable
102	56B40442T07	Packing, Front Frame
103	56B40230G08	Sack, Polyethylene
104	56A81874F01	Pad, Packing
★ 105	01T80478F01	Unit, Remote Control
▲ 105	01T80478F02	Unit, Remote Control

Symbol No.	Part No.	Description
● 105	01T80478F02	Unit, Remote Control
■ 105	01T80478F02	Unit, Remote Control
106	60T58064F01	Battery, Sum-3
107	56D80311F01	Tray, Packing
★ 108	56S71001F68	Carton, Packing
▲ 108	56S71001F81	Carton, Packing
■ 108	56S71001F81	Carton, Packing
● 108	56S71001F81	Carton, Packing

Note: ● : For North American model only(UZ), ▲ : For Canadian model only(UQ)  
 ■ : For General Foreign model only(EK), ★ : For Japanese model only(JA)  
 Others : Common

# Cabinet Assembly Parts List

The parts without part numbers are not supplied.

Symbol No.	Index	Part No.	Description
★	1	6-B 64D80159F01	Panel, Front
▲	1	6-B 64D80159F02	Panel, Front
●	1	6-B 64D80159F02	Panel, Front
■	1	6-B 64D80159F02	Panel, Front
	2	2-B 15C80188F01	Cover, Top
	3	4-B 01V81200F42	Assembly, Frame Front
★	5	2-G 15D80186F01	Cover, Rear
▲	5	2-G 15D80186F02	Cover, Rear
●	5	2-G 15D80186F02	Cover, Rear
■	5	2-G 15D80186F03	Cover, Rear
	7	5-A 36A80165F01	Knob, Power
	8	5-D 36A80164F01	Knob, Push
	9	4-C 36A80166F01	Knob, Timer Switch
	10	5-C 36A80167F01	Knob, Slide Volume
	14	5-C 61A80176F01	Crystal Digital "C"
	15	01A80230F01	Assembly, Trannleg
	16	09T51410F01	Holder, Fuse
	17	1-G 16T82537F01	Cap, Pin Jack
	18	2-E 03S43997P83	Screw, Bind (M2.6×4)
	22	03S44205G51	Screw, Pan (M4×8)
	23	03S71031F04	Screw, Bind (M3×8)
	25	2-C 14A68459F01	Insulator, Cover
	26	03S40018G08	Screw, Tpg (M3×8)
	27	2-H 03A82468F01	Screw, Tpg (M3×10)
	29	03S40036U01	Screw, W/Washer (M4×8)
	30	2-C 07B80191F01	Bracket, Power
	31	2-D 43A70227F01	Spacer, Pipe
	32	29C41045P05	Lug, Wrap 54mm
	33	4-E 75A42565P25	Cushion, Rubber
	34	03S71031F09	Screw, Countersink (M3×8)
	35	2-G 03S44205G03	Screw, Pan (M3×8)
	36	4-C 07A80196F01	Bracket, Phone Jack
	37	2-H 43A68205F03	Bush, Deck
★	38	1-H 43B41625J05	Stopper, Cord
▲	38	1-H 43B41625J02	Stopper, Cord
●	38	1-H 43B41625J02	Stopper, Cord
■	38	1-H 43B41625J02	Stopper, Cord
	40	2-H 43A82528F01	Spacer, Din Jack
	41	2-B 26A81506F02	Shield, Seal
	42	03S40036U24	Screw, W/Washer (M3×10)

Symbol No.	Index	Part No.	Description
	44	4-G 43A82529F01	Spacer, Plate
	45	4-H 03A66790F02	Screw, Bind (M3.2×5)
	47	4-H 43A80199F01	Spacer, Digital
	51	03S43997P76	Screw, Bind (M3×6)
	52	43A53357F04	Spacer, LED
	57	6-B 03S40012G98	Screw, Tpg (M3×8)
	58	41A80342F01	Spring, Earth
	59	5-D 43A80198F01	Bush, Lamp
	60	2-B 75S72374F46	Cushion, Dam.
	61	75A67064F01	Felt
	62	03S44205G28	Screw, Bind (M4×16)
	63	1-E 03D40014G12	Screw, W/Washer (M2.6×4)
	64	1-E 64A80178F01	Panel, Mech
	66	2-D 43T53136F01	Bush, Cap
	67	4-D 07A80180F01	Frame, FL
	68	4-C 01V81200F47	Assembly, Volume/Switch P.C. Board
	69	4-C 14A68351F01	Insulator, Jack "A"
	71	2-G 29C41045P07	Lug, Board-In 30mm
	73	5-E 07A80194F01	Frame, Lever Holder
	74	75S72374F38	Cushion, Rubber
	75	03S81717F01	Screw, Round (M3×6)
	76	3-D 14S53018F43	Insulator
	77	3-B 14S53018F07	Insulator
●	78	2-D 54B62266F11	Label, Fuse 4A-125V
▲	78	2-D 54B62266F11	Label, Fuse 4A-125V
■	78	2-D 54B62266F02	Label, Fuse 4A-125V
▲	83	2-F 54B62266F10	Label, Fuse 5A-125V
●	83	2-F 54B62266F10	Label, Fuse 5A-125V
▲	84	2-F 54B62266F12	Label, Fuse 3A-125V
●	84	2-F 54B62266F12	Label, Fuse 3A-125V
▲	85	2-F 54B62266F28	Label, Fuse 1A-250V
●	85	2-F 54B62266F28	Label, Fuse 1A-250V
▲	87	2-C 03D40014G04	Screw, W/Washer (M3×6)
	88	3-D 03S71031F03	Screw, Bind (M3×6)

Note: ● : For North American model only(UZ), ▲ : For Canadian model only(UQ)  
 ■ : For General Foreign model only(EK), ★ : For Japanese model only(JA)  
 Others : Common

# Exploded View (Cabinet)

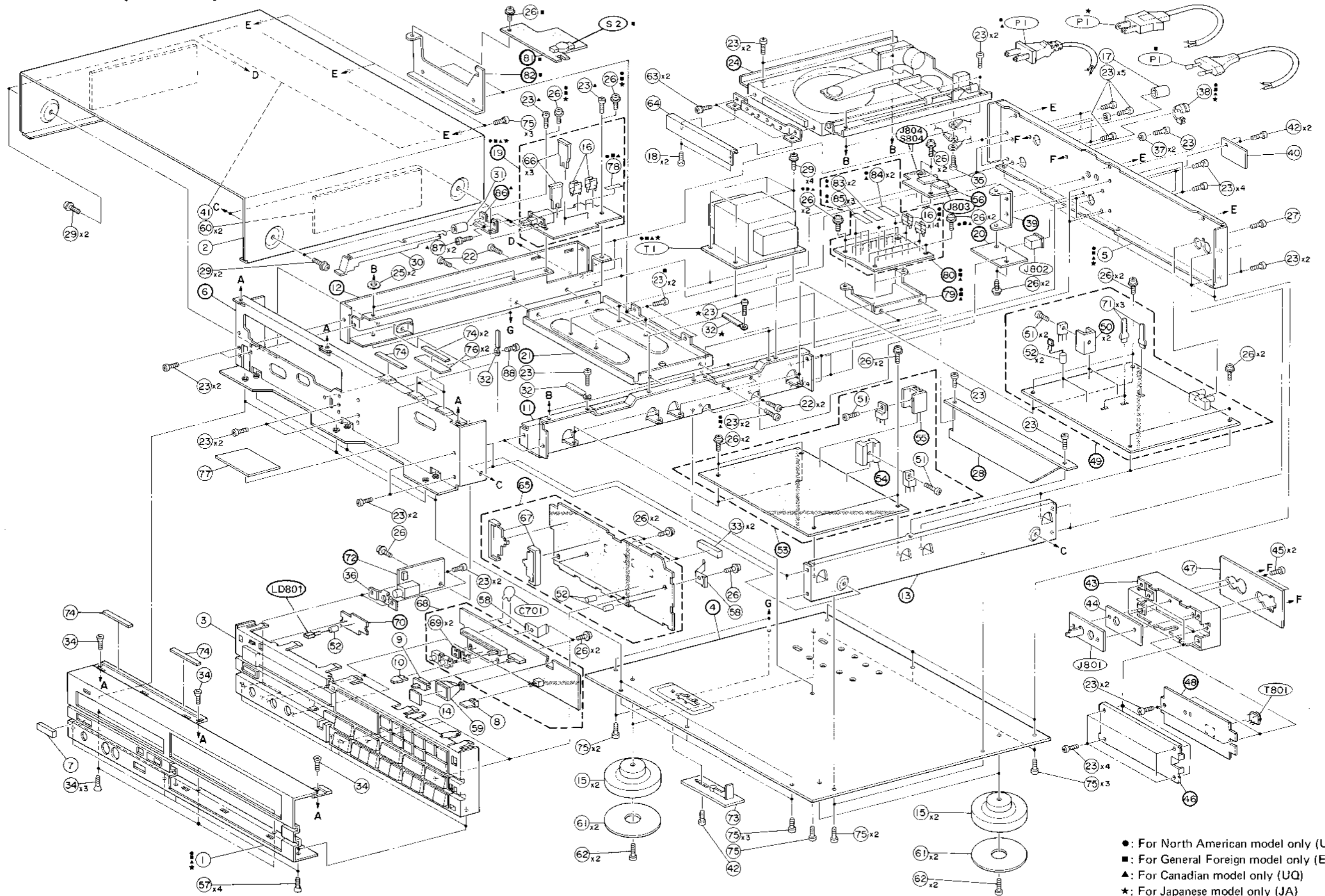

- : For North American model only (UZ)
- : For General Foreign model only (EK)
- ▲ : For Canadian model only (UQ)
- ★ : For Japanese model only (JA)
- Others: Common

### Exploded View (CD Mechanism) (1/3)

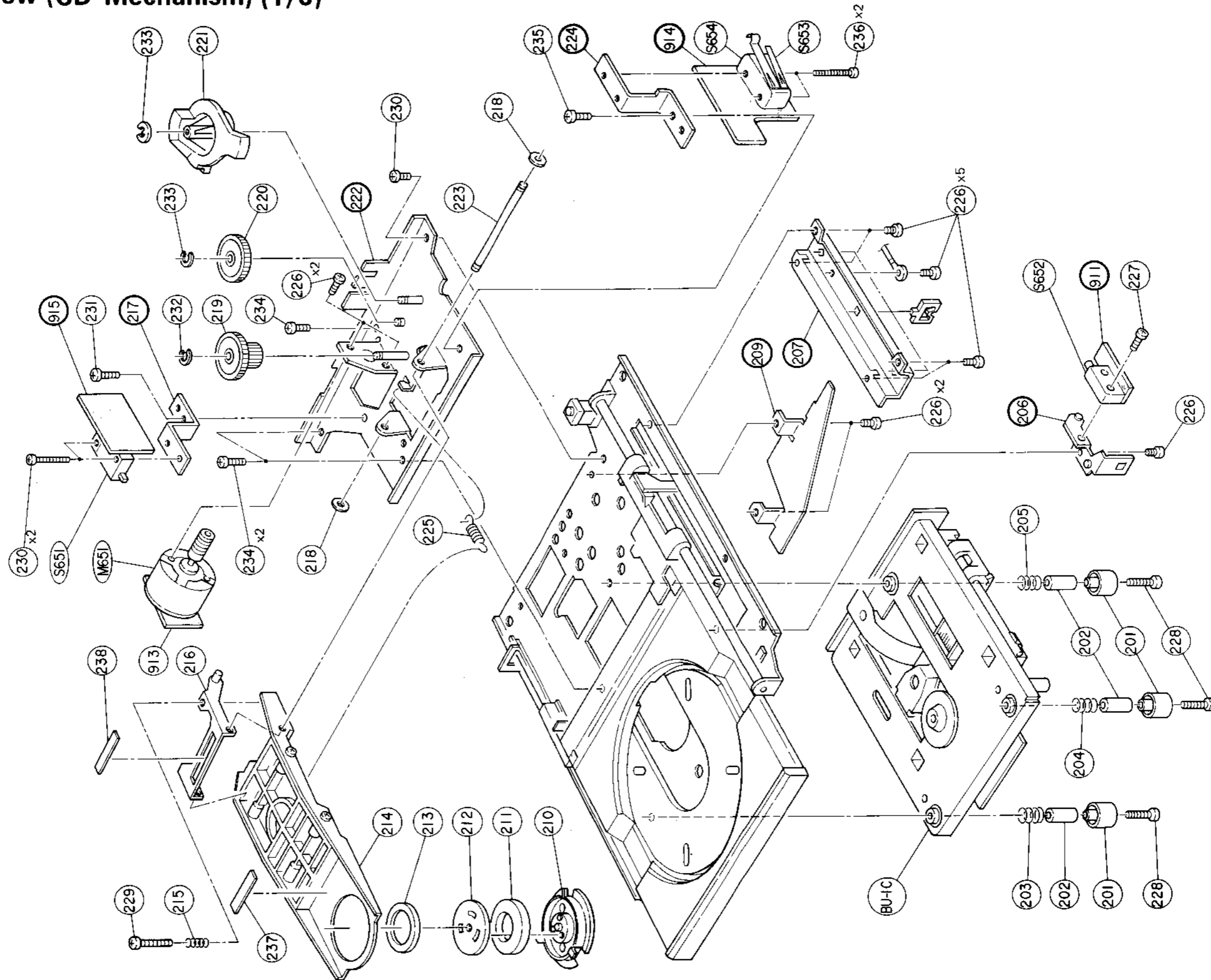

# Exploded View (CD Mechanism) (2/3)

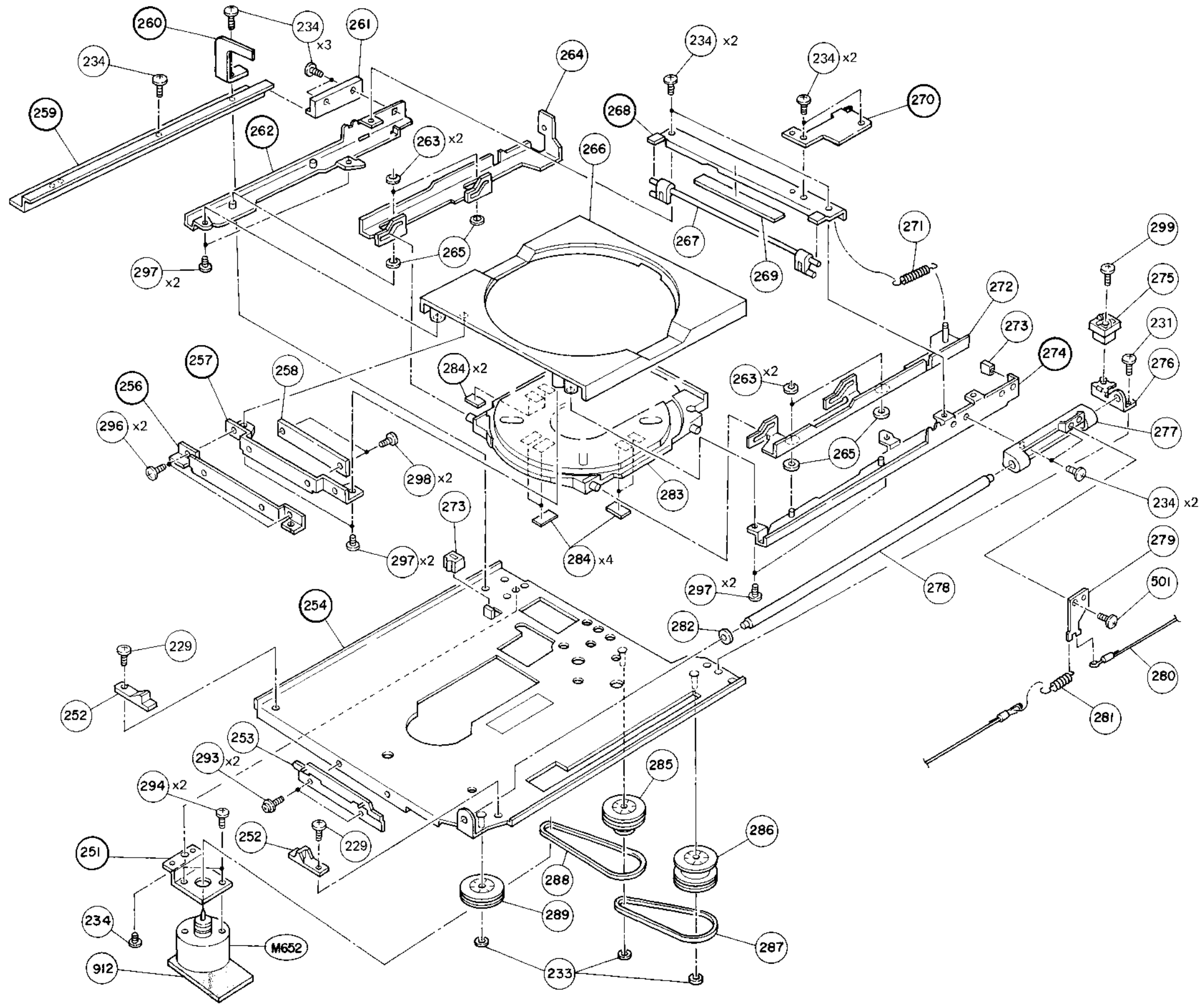





# CD Mechanism Assembly Parts List

Note: The parts without part number are not supplied.

Symbol No.	Index	Part No.	Description
201		43E03314S01	Insulator Pole (A)
202		43E02955S01	Spacer
203		41E03315S01	Spring (Insulator B)
204	5-G	41E03316S01	Spring (Insulator A)
205	3-G	41E03317S01	Spring (Insulator C)
210	5-D	49E02742S01	Pulley
211	5-D	59E02726S01	Magnet
212	5-D	07E02959S01	York
213	5-D	75E02949S01	Cushion
214	5-C	01E03319S01	C Arm Assembly
215	5-B	41E02952S01	Spring (Arm Reinforcement Bracket)
216	4-B	01E02718S01	Arm Assembly
218		04E02927S01	Washer
219	2-B	44E02739S01	Gear (A)
220	2-C	44E02740S01	Gear (B)
221	1-B	44E03320S01	Cam Gear
223	2-D	47E03321S01	C Arm, Shaft
225	3-D	41E02951S01	Spring (C Arm)
226		03E02990S01	Screw (M2.6×3)
227	2-G	03E02989S01	Screw (M2.6×8)
228		03E03002S01	Screw (M3×20)
229		03E02993S01	Screw (M2.6×16)
230		03E03323S01	Screw (M2.6×16)
231		03E03003S01	Screw (M3×5)
232	2-B	04E02997S01	Ring, E (M5)
233		04E02996S01	Ring, E (M3)
234		03E03324S01	Screw (M3×5)
235		03E03000S01	Screw (M3×3)
236	1-F	03E02986S01	Screw (M2.3×14)
237	6-C	56E02982S01	DT PS Sheet (C)
238	4-B	56E02983S01	DT PS Sheet (B)
252		07E02947S01	Support, Guide
253	5-C	01E02864S01	Bracket, Table Assembly
258	3-C	64E02978S01	Plate
261	1-C	07E02973S01	Sub Guide
263		04E02927S01	Washer
264	1-D	44E02971S01	Disc, Cam (L)
265		04E03328S01	Washer (M3)
266	2-E	15E03329S01	Disc, Table

Symbol No.	Index	Part No.	Description
267	2-E	45E03330S01	Lever
269	2-E	14E02967S01	Sheet
271	2-F	41E02960S01	Spring (Disc Cam)
272	2-G	01E02860S01	Disc, Cam (R) Assembly
273		43E03332S01	Stopper, Rubber
275	2-H	45E02958S01	Table Stopper
276	3-H	07E02962S01	Bracket, Shaft Holder (R)
277	3-H	07E02974S01	Guide, Shaft Holder (R)
278	4-F	47E02964S01	Guide, Shaft (R)
279	4-H	27E02963S01	Bracket, Rope
280	4-H	30E02961S01	Rope
281	4-H	41E03333S01	Spring (Rope)
282	4-E	75E02957S01	Cushion (A)
283	3-E	01E03334S01	Disc, Plate Assembly
284		14E02956S01	DT, PS Sheet
285	5-E	49E03335S01	Pulley (A)
286	5-E	49E03336S01	Pulley (C)
287	6-E	42E03337S01	FF Belt
288	5-D	42E02738S01	Belt
289	6-D	49E03338S01	Pulley (B)
293	5-C	03E02988S01	Screw (M2.6×8)
294	5-B	03E03339S01	Screw (M2.6×3)
296	3-B	03E02991S01	Screw (M2.6×4)
297		03E03007S01	Screw Tapping (M3×8)
298	3-D	03E03008S01	Screw (M2.6×5)
299	2-H	03E03010S01	Screw (M3×16)
301	5-C	01E02714S01	Bracket, Motor Assembly
302	5-B	07E02924S01	Holder
304	4-B	49E02715S01	Rotary, Assembly
305	4-C	04E02928S01	Washer (M3)
306		47E03340S01	Slider, Shaft
307		14E02937S01	Insulator
308	1-D	49E03341S01	Disc, Pulley Assembly
309	1-D	41E03342S01	Spring (Centering Cap)
310	1-D	49E03343S01	Centering, Cap
311	1-D	04E02927S01	Washer
312	1-F	05E03344S01	Nylon Rivet
313	4-G	45E03345S01	Lock, Lever
314	4-G	45E03346S01	Lock, Lever Spring
315	4-G	07E02934S01	Rod, Holder

Symbol No.	Index	Part No.	Description	Symbol No.	Part No.	Description
316		01E02853S01	Linear, Magnet Assembly			
317	4-E	07E02935S01	Bearing, Holder			
318	4-E	07E02734S01	Shaft, Holder			
319	6-D	43E03347S01	Holder, Reed (A)			
320	6-A	43E03348S01	Holder, Reed (B)			
322	4-D	43E02732S01	Ball, Bearing			
323		03E03006S01	Screw, Tapping (M2.6×8)			
324		03E02991S01	Screw, Tapping (M2.6×4)			
325		03E02992S01	Screw, Tapping (M2.6×5)			
326	4-C	03E03009S01	Screw, (M2.6×8)			
327	2-D	03E02987S01	Screw, (M2.6×3)			
328		04E03012S01	Washer (M2.6)			
329		03E03349S01	Screw (M2.6×10)			
331	4-F	03E03350S01	Screw (M2.6×16)			
333	4-D	04E02995S01	Stop, Ring (M2.3)			
334		45E02940S01	Holder, Slider (C)			
335	1-F	64E03351S01	Holder, P-Plate			
336	6-C	75E03352S01	Support, Bracket			
337	6-C	03E03001S01	Screw (M3×5)			
501	4-H	03E03005S01	Screw (M2.6×5)			
902	5-A	84E02852S01	Motor Mount			
912	6-B	84E02920S01	Loading Motor P.C. Board			
913	4-B	84E02921S01	Chucking Motor P.C. Board			
916	1-F	84E02713S01	FPC Mount			

NJM4558D: IC151, 202, 206  
 NJM5532: IC4301 ~ 4306

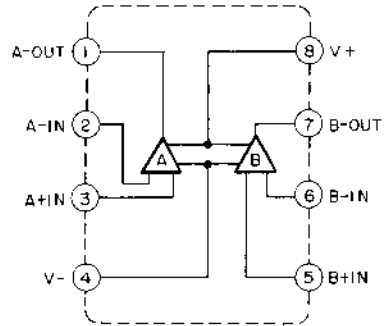
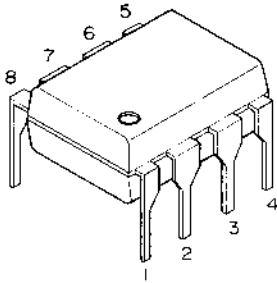

CX20108: IC201

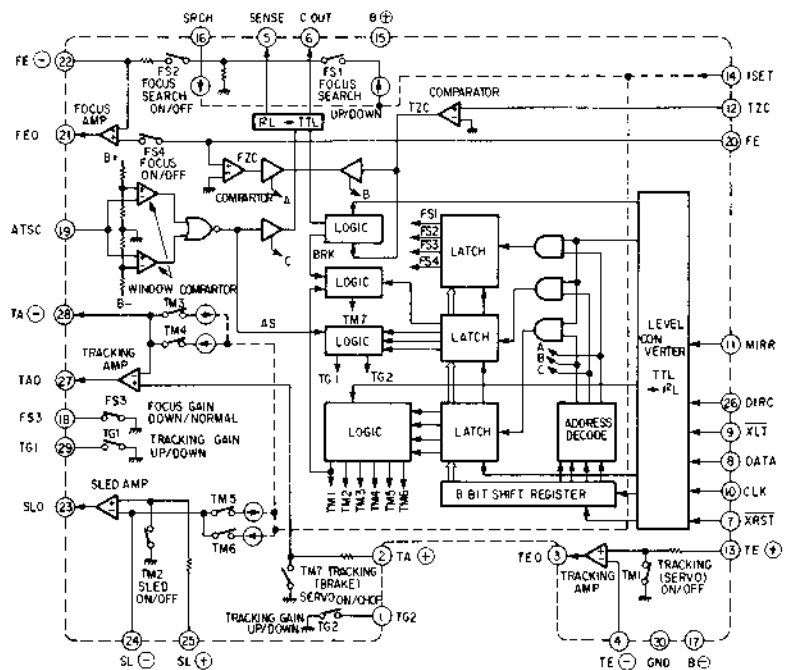
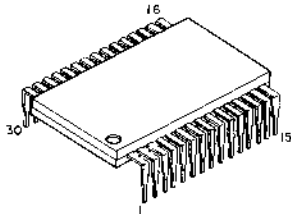

# Semi-Conductor Lead Identifications

IR3C02: IC1

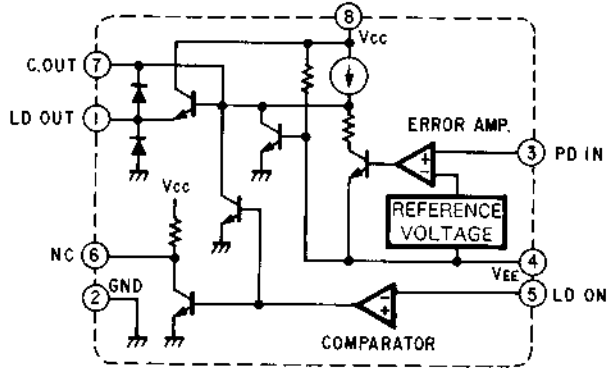
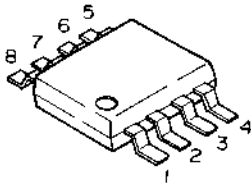

CX20109: IC101

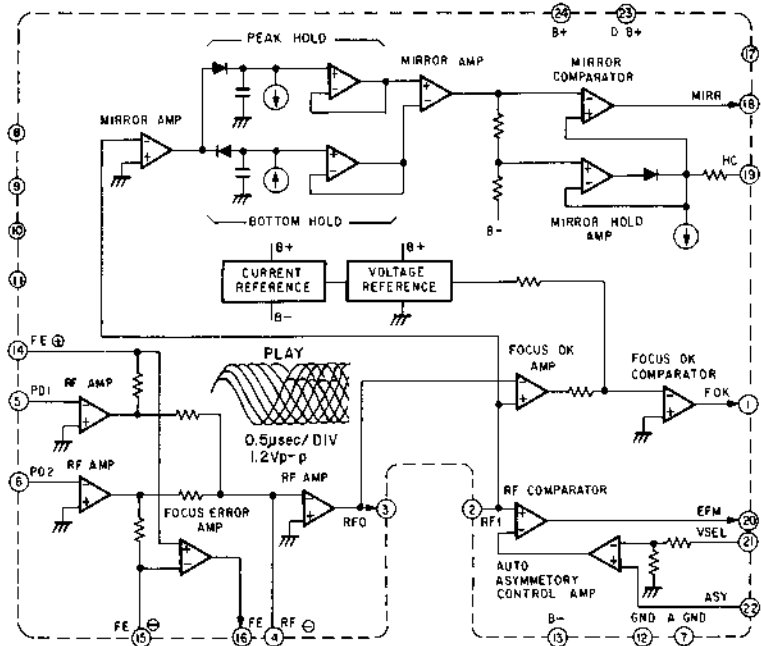
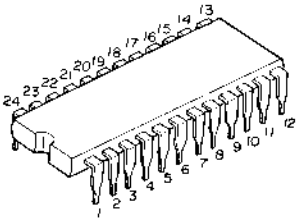

NJM4558: IC102

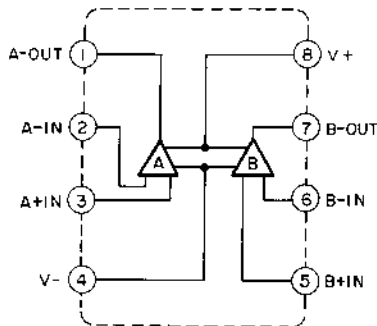
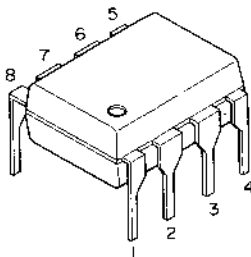

CX23035: IC203

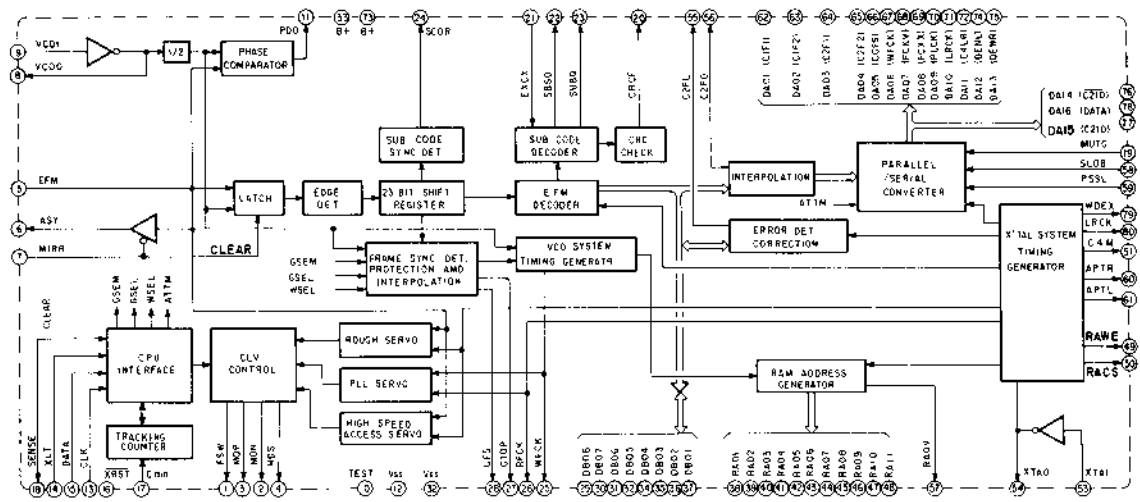
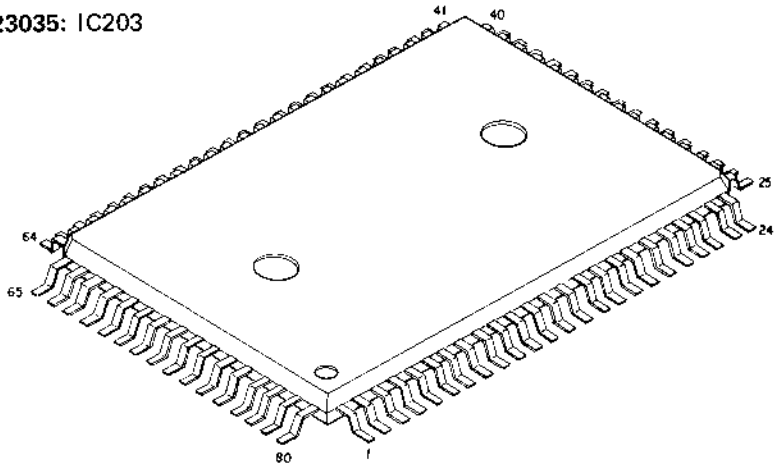

μPD449G: IC204

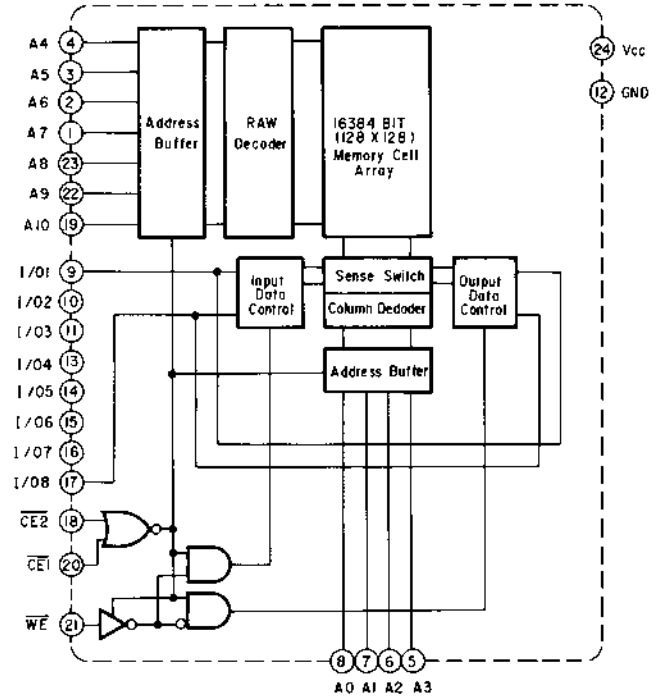
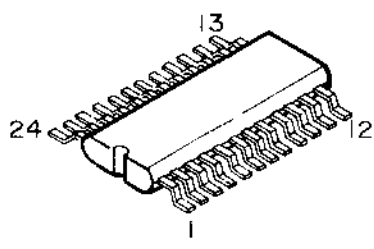

**CX5816M: IC204**

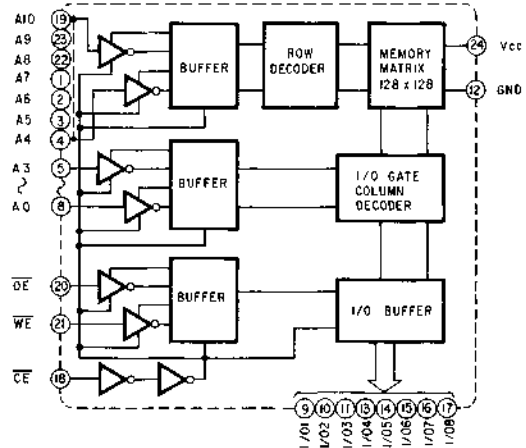
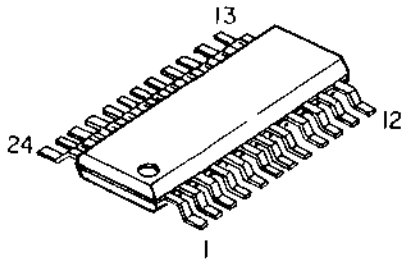

- M5238P : IC205, 4401, 4402
- NJM2903D : IC212
- M5216P : IC501

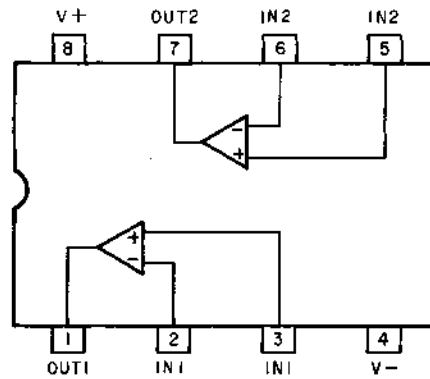
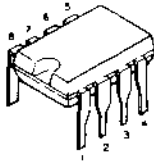

**SM5802A : IC207**

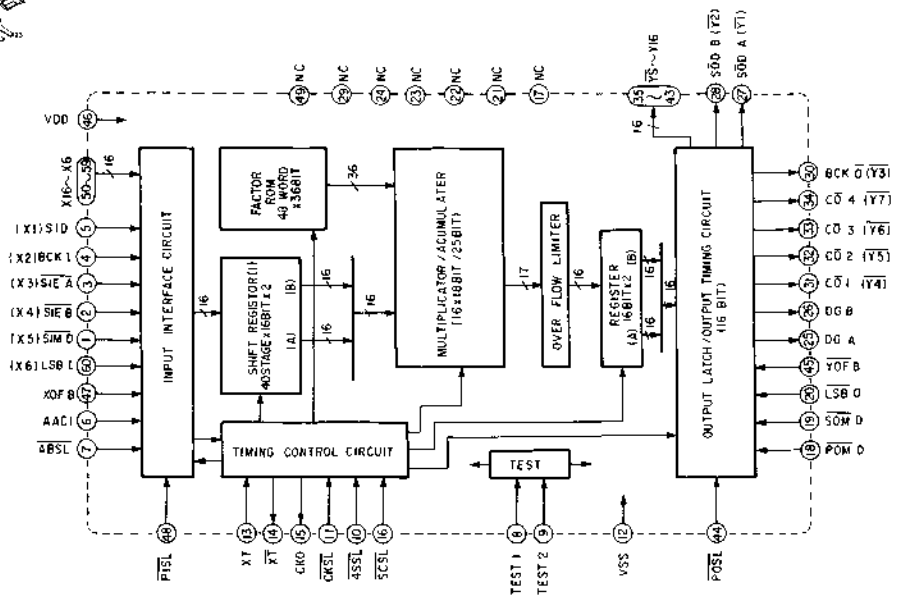
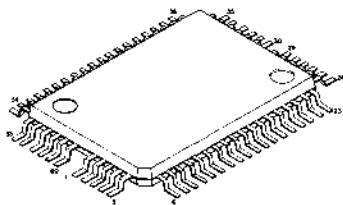

NJM7805: IC213  
 NJM7812: IC4501

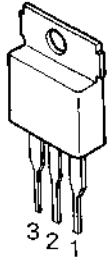

1 : OUTPUT  
 2 : COMMON  
 3 : INPUT

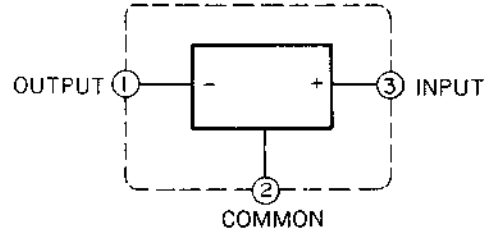

NJM7905: IC214  
 NJM7912: IC4502

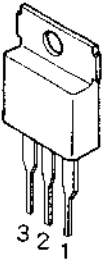

1 : OUTPUT  
 2 : INPUT  
 3 : COMMON

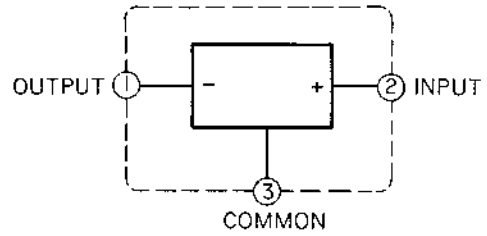

74753F01: IC301

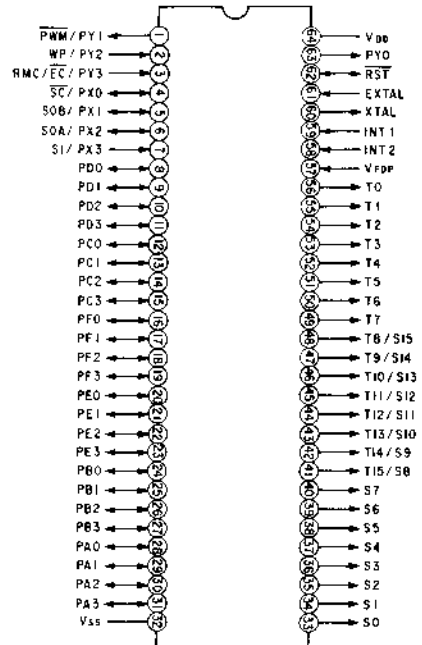
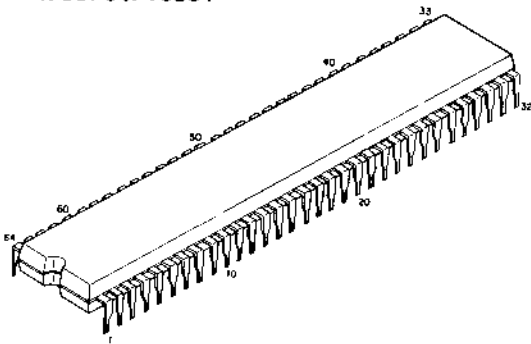

CDX1075P: IC208

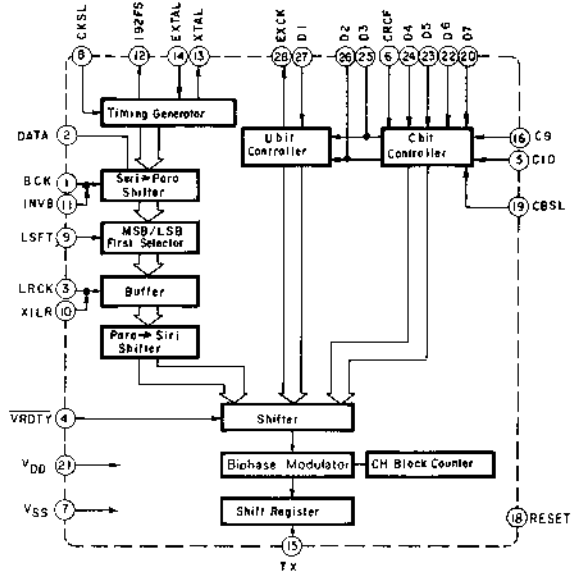
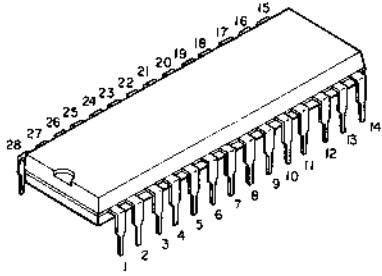

TC74HCU04P: IC210

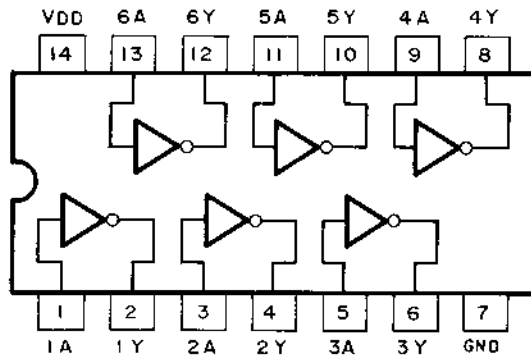
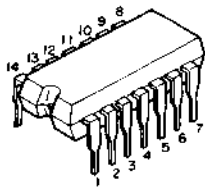

M6404A-117: IC211

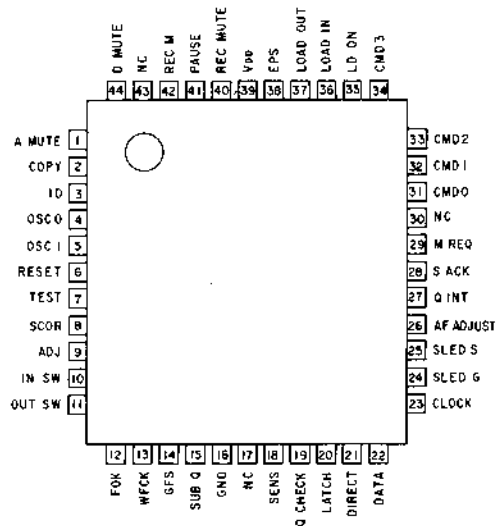
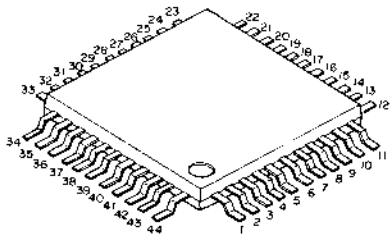



LF356: IC4201, 4202

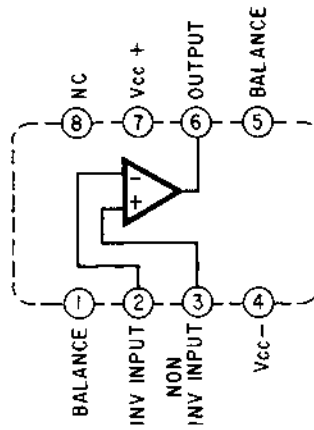
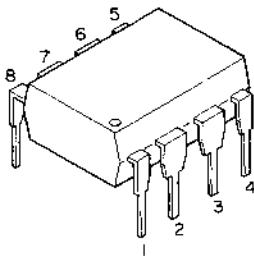

$\mu$ PD4053BC: IC4203

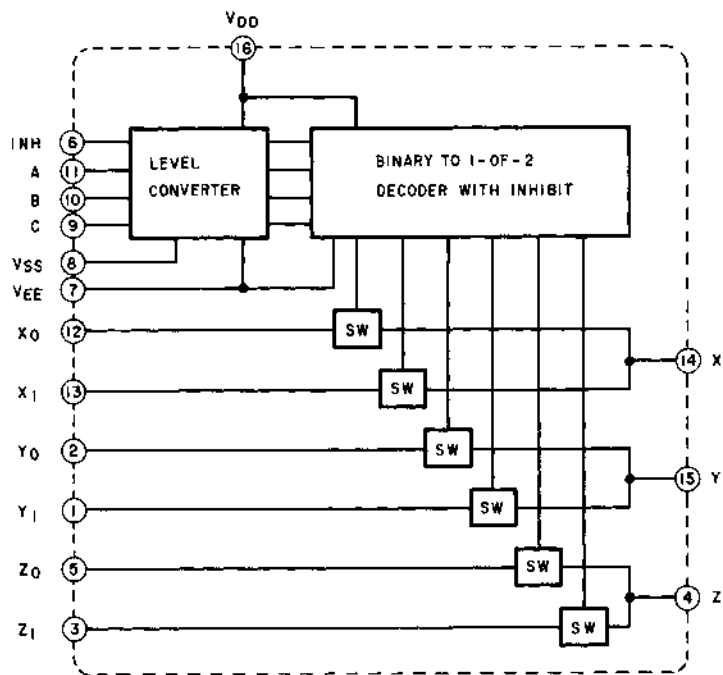
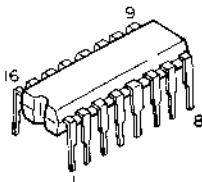

NJM5532: 1C4301, 4302, 4303, 4304, 4304, 4305, 4306

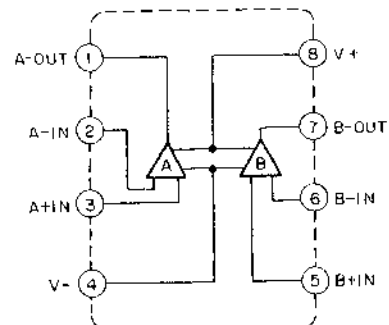
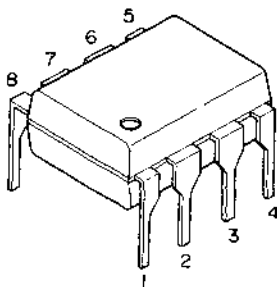

$\mu$ PD4028BP: IC302

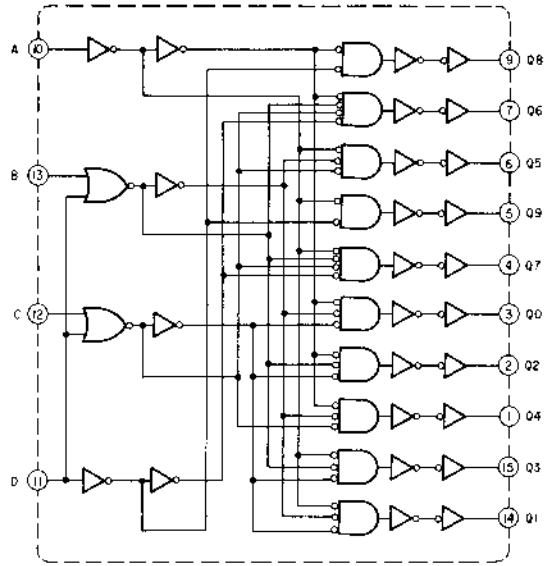
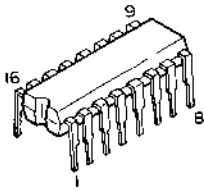

BX1317: IC701

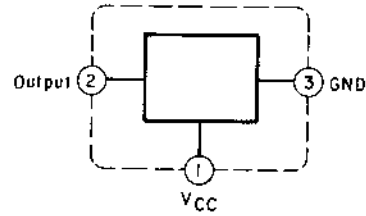
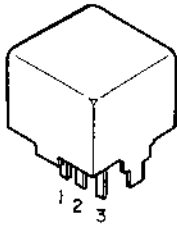

PCM56JP: IC4101

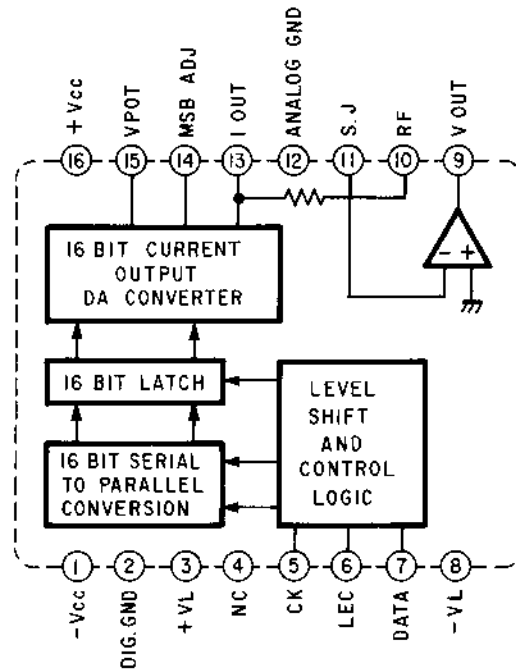
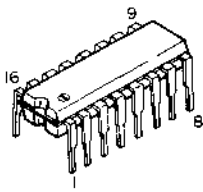

# Schematic Diagram (1/2)

IC	IC4101	IC4203	IC4201	IC4501	IC4301	IC4303	IC4304	IC4306	IC4308
Transistor (Q)	Q4501 Q4503 Q4505 Q4507 Q4509 Q4511 Q4513 Q4551 Q4553	Q301 Q302	Q4201 Q4202	Q4502 Q4504	Q4601 Q4603	Q4301 Q4302	Q4303 Q4304	Q4305 Q4306	Q4307 Q4308
Diode (D, LD, ZD)	LD4501 LD4502	ZD4501 ZD4502 ZD4503 ZD4504	D4603 D4602 D4601 ZD4601 D4604						

## Audio P.C. Board

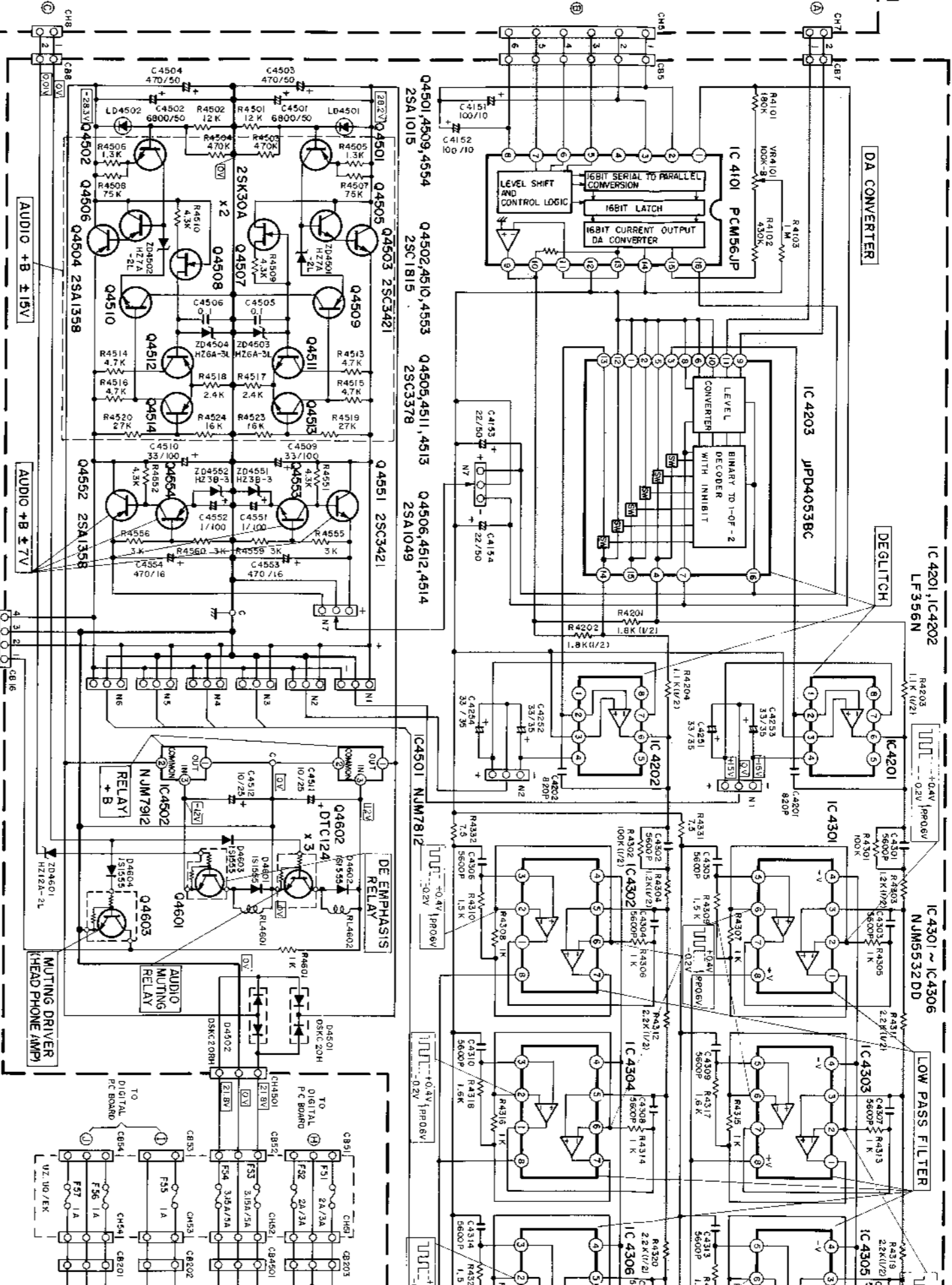

## FL Keyboard P.C. Board

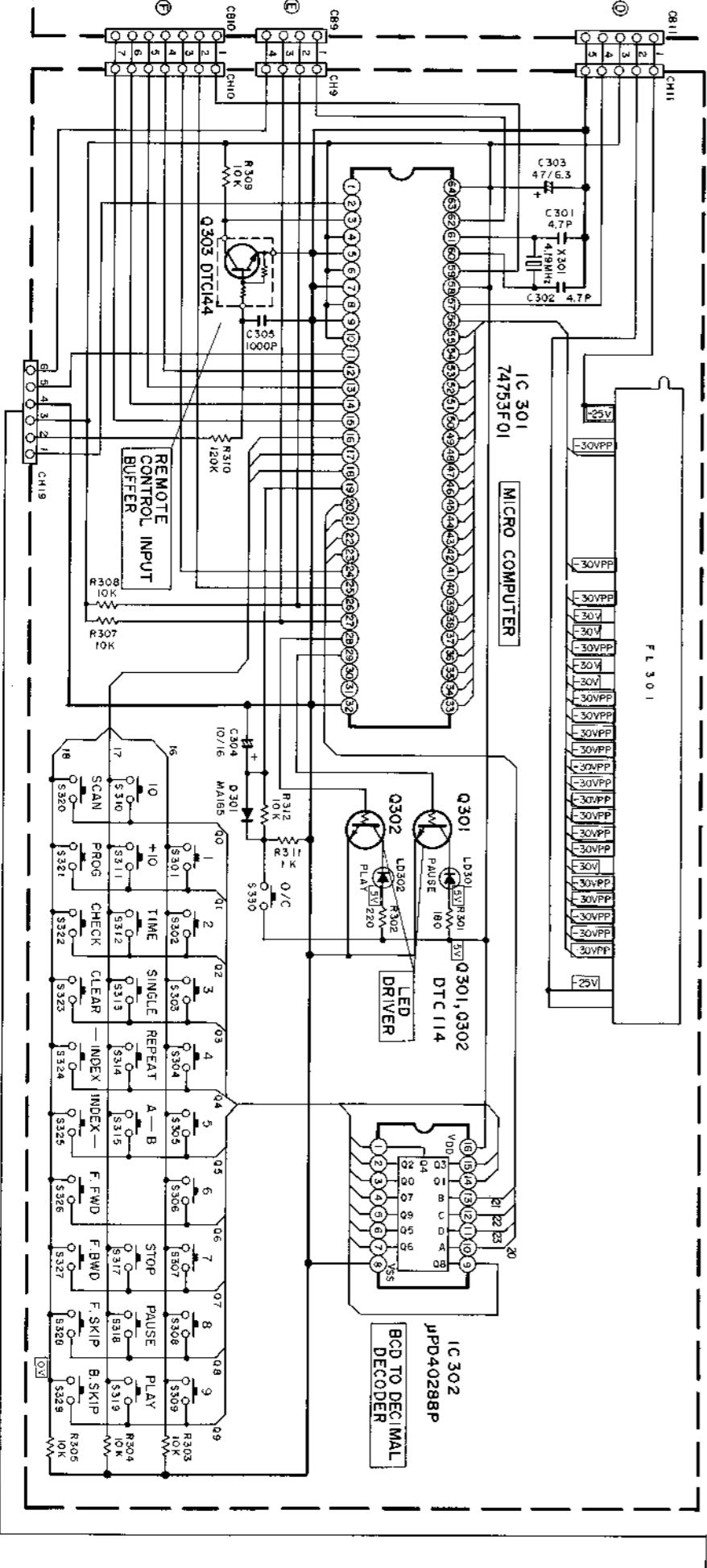



# Schematic Diagram (2/2)

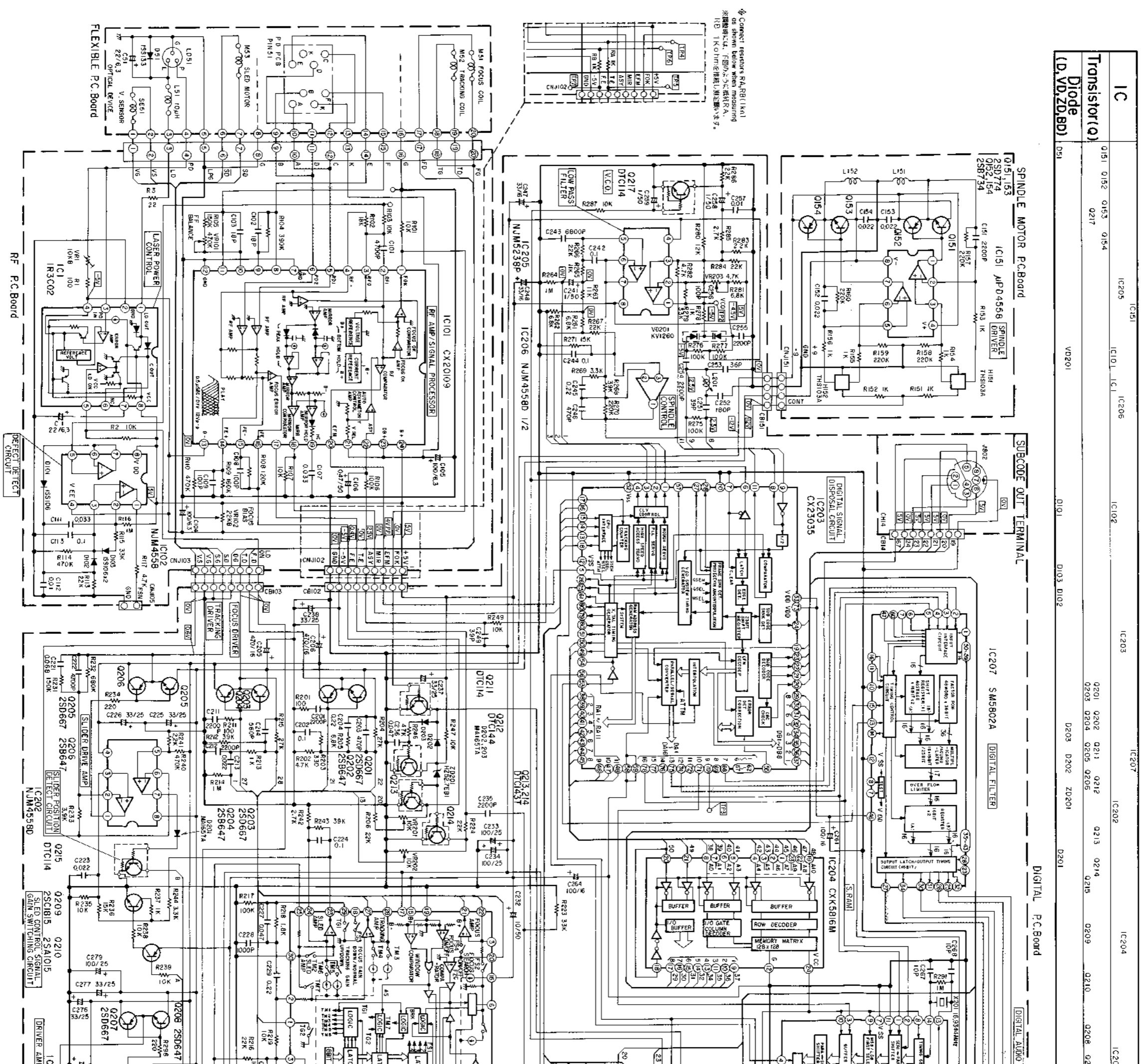

\* Connect resistors RA, RB, RL (k $\Omega$ ) as shown below when measuring. \* 接続抵抗 RA, RB, RL (k $\Omega$ )は測定時接続する。



2SD667: Q201, 203, 205, 207  
 2SB647: Q202, 204, 206, 208

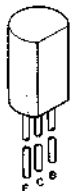

2SC1815: Q209, 4502, 4510, 4553  
 2SA1015: Q210, 4501, 4509, 4554

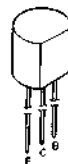

DTC114: Q211, 215, 216, 217  
 DTC144: Q212  
 DTC143T: Q213, 214  
 DTC114T: Q303

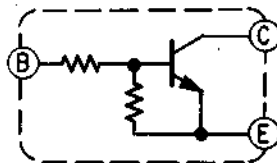
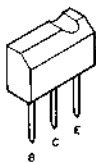

2SB941: Q218



2SC3421: Q4503, 4551  
 2SA1358: Q4504, 4552



2SC3378: Q4505, 4511, 4513  
 2SA1049: Q4506, 4512, 4514



DTC124: Q4601, 4602, 4603

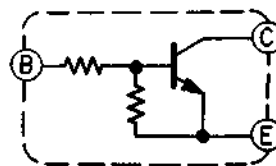

2SK30A: Q4507, 4508



2SD274: Q151, 153, 651  
 2SB734: Q152, 154

