

# SERVICE MANUAL

## DUO-BETA CIRCUIT STEREO INTEGRATED AMPLIFIER **L-215**

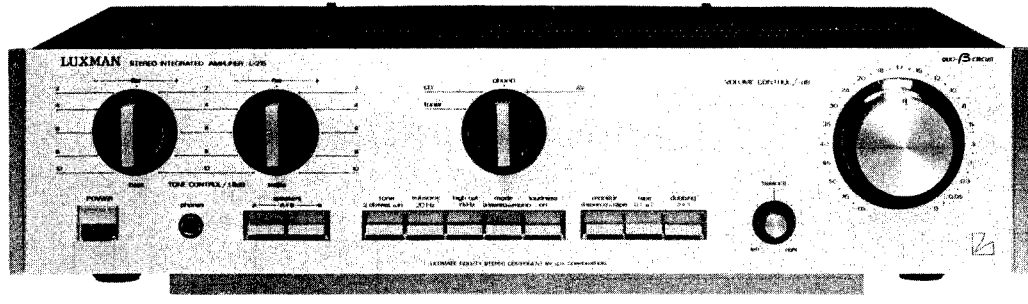

# Contents

Block Diagram . . . . .	1
Adjustment Procedures . . . . .	2
Packing Material Parts List . . . . .	2
Exploded View . . . . .	3
Exploded View Parts List . . . . .	4,5
Pre Main Amp PCB . . . . .	6
Tone Control PCB . . . . .	7
Function SW PCB . . . . .	7
VR Control PCB . . . . .	7
AV Input Terminal PCB . . . . .	7
Destination's Parts List . . . . .	7
Pre Main Amp PCB Parts List . . . . .	8,9
Tone Control PCB Parts List . . . . .	9
Function SW PCB Parts List . . . . .	9
VR Control PCB Parts List . . . . .	9
AV Input Terminal PCB Parts List . . . . .	9
IC Handling Guide . . . . .	10
Schematic Diagram . . . . .	11
Specifications . . . . .	12

## Block Diagram

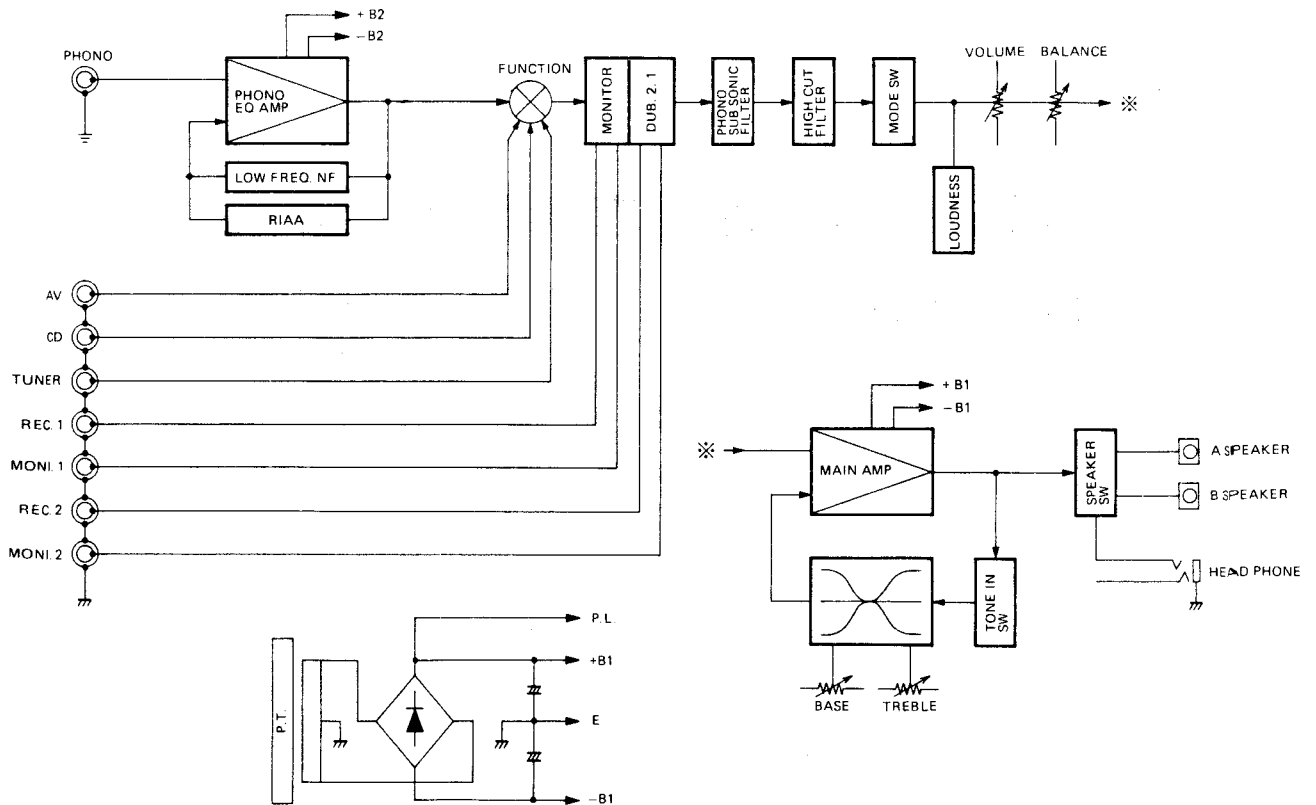

# Adjustment Procedures

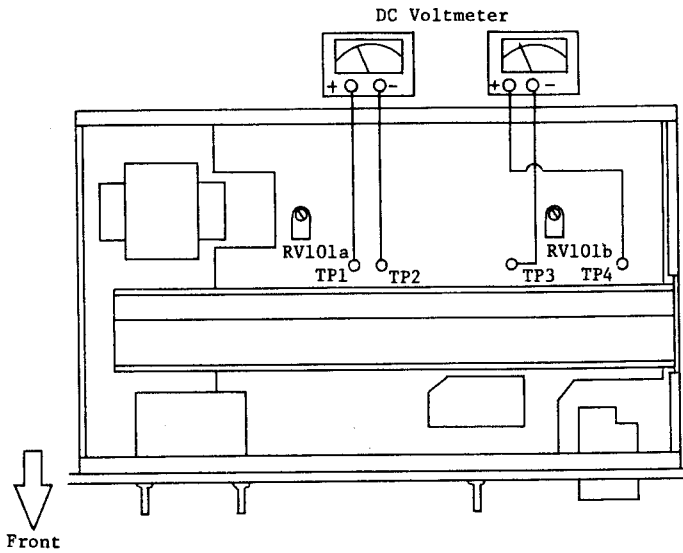

## Bias (Idle) Current Adjustment

1. Connect a DC Voltmeter in between TP1 and TP2 on L-ch and or TP4 and TP3 on R-ch, Making TP1 and TP4 positive respectively.
2. Adjust the RV101a and RV101b to obtain  $15\text{mV} \pm 5\text{mV}$  reading on the meter.

## Packing Material Parts List

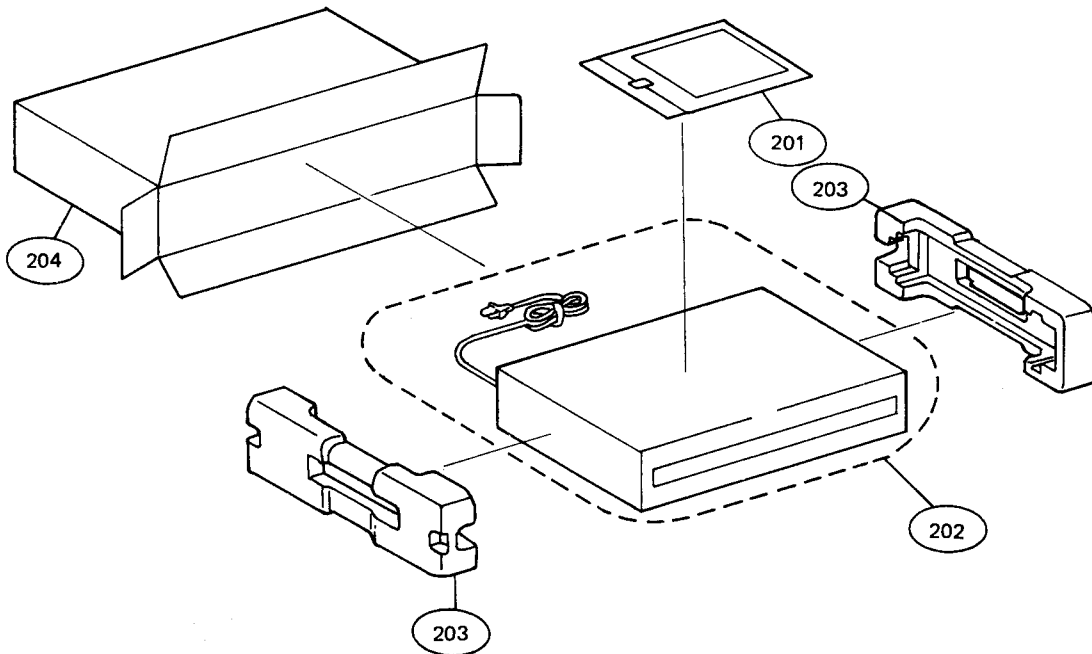

## Packing Material Parts List

Index	Symbol No.	Stock No.	Description	Remarks
	201	68P65432F35	Owner's Manual	
	202	56B63425F11	S, Poly 620x480	
	203	56C56637F01	Packing Tray	
	204	56S60482F38	Carton, Packing	

# Exploded View

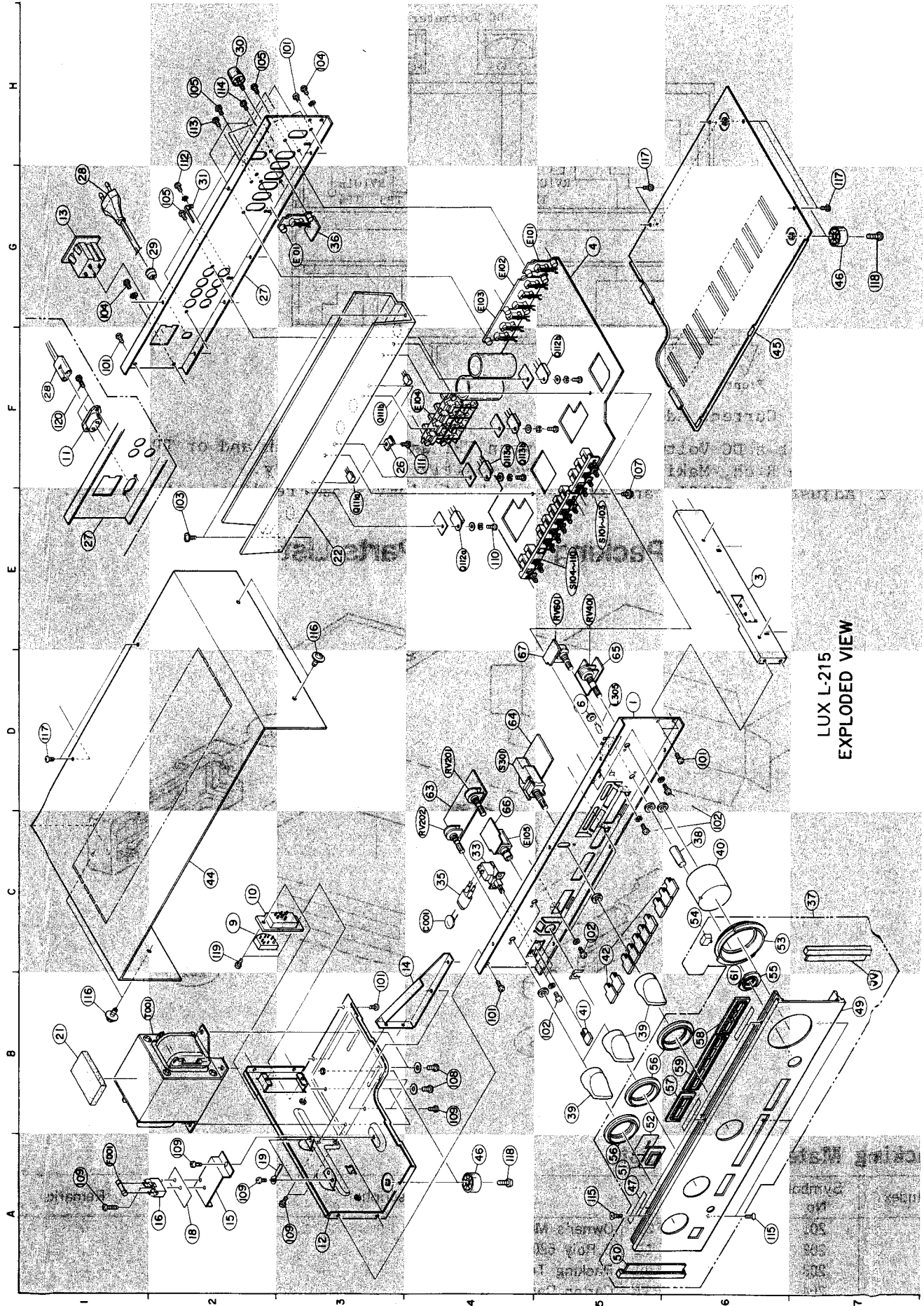

LUX L-215  
EXPLODED VIEW

# Exploded View Parts List

Note : \*The parts whose parts numbers are not entered will not be supplied.

Index	Symbol No.	Stock No.	Description	Remarks
D5	1	*	Chassis Front	
E6	3	*	Bracket, R	
G5	4	*	Ass'y Pre M/A PCB	
D5	6	43A62016F02	Bushing, UZ1077-2	
C2	9	09T51830F01	Plug, Switch P-2120	AK
C2	10	09T51831F01	Socket, Switch M-1615	AK
F1	11	09T67078F01	Inlet, 2P	AK
A3	12	*	Bracket, Trans	
G1	13	09T57066F01	AC, Outlet S2-724B-04	UP
C4	14	*	Bracket, Trans	
A2	15	*	Bracket, Fuse	
A2	16	09T51074F01	Fuse Holder	
		09T51828F01	Fuse Holder X-N1157	UP
A2	18	*	Spacer, Fuse	
A2	19	29C41045P01	Lug, Wrap Around	
	20	*	Cushion, Rubber	
B1	21	*	Spacer, 60x34	
E3	22	07C56635F01	Heat Sink, 15	
F3	26	*	Support, Tr	
E1, G2	27	15D56636F20	Cover, Rear	SK
		15D56636F23	Cover, Rear	AK
		15D56636F28	Cover, Rear	UP
F1, G1	28	28T43182P02	Plug, AC Cord	SK
		30T67077F01	Cord Set	AK
		28T55335P02	Plug, AC Cord	UP
G2	29	43B41625J02	Support, Cord	SK, UP
H2	30	29T66964F01	Terminal, GND	
G2	31	*	Lug, Wrap Around	
C4	33	40T45561F02	Switch Power (SDLIP)	
C4	35	*	Bush, Cap	
G3	36	*	Ass'y AV Input	
C7	37	01V66800F63	Ass'y Panel Front	
C6	38	36A66510F01	Knob, Rotary VR A	
		36A66510F02	Knob, Rotary VR A	UP
B5	39	36B66511F01	Knob, Rotary VR B	
		36B66511F03	Knob, Rotary VR B	UP
C6	40	36B66512F01	Knob, Rotary VR C	
		36B66512F03	Knob, Rotary VR C	UP
B5	41	36A56639F02	Knob, Push 1171	
C5	42	36A66836F02	Knob, Push	
C2	44	15C56629F02	Cover, Top	
F6	45	*	Cover, Bottom	
A4, G7	46	75A52969F01	Pad, Trann-leg	
A5	47	*	Insulator, 50x5	
B7	49	64D66508F02	Panel, Front	
A5, B7	50	07B56624F03	Frame, Panel Side	
A5	51	61A56641F01	Crystal, Indicator	
B5	52	43A56628F01	Spacer, Power	
C6	53	07B56643F01	Frame, Knob 1140	
C6	54	61A61746F01	Lens 1020-WG1020	
C6	55	07A56645F01	Frame, Knob 1156	
A5, B5	56	07A56648F01	Frame, Knob	
B6	57	07C56907F01	Frame, Knob 1153	
B6	58	07B56646F01	Frame, Knob 1154	
B6	59	07C56647F01	Frame, Knob 1155	
D4	63	*	Ass'y, Tone Control PCB	

Index	Symbol No.	Stock No.	Description	Remarks
D4	64	※	Ass'y,Function SW PCB	
D5	65	※	Ass'y,VR Control PCB	
D4	66	※	Ass'y,HD Phone PCB	
D4	67	※	Ass'y,Balance Control PCB	
B3,B4	101	03S44205G02	Screw,T-Tite M3x6	
B5,C5	102	03C40014G04	Screw,MCH M3x6	
E2	103	03C42723U02	Screw,CUP M3x8	
G1,H3	104	03S40036U18	Screw,T-Tite M3x8 T.L.	
G2,H2	105	03S40012G41	Screw,Tapping M3x8	
E5	107	03S40018G02	Screw,Tapping M3x8	
B4	108	03S40036U01	Screw,T-Tite M4x8	
A1,A2	109	03S44205G02	Screw,T-Tite M3x6	
E4	110	03C40121T15	Screw,MCH M3x12	
F4	111	03S40012G28	Screw,Tapping M3x8	
H2	112	03S40036U18	Screw,T-Tite M3x8 T.L.	
H2	114	03S40012G41	Screw,Tapping M3x8	
A5,A6	115	03S40012G55	Screw,Tapping M3x8	
B1,E3	116	03S40036U01	Screw,T-Tite M4x8	
D1,G7	117	03S44205G02	Screw,T-Tite M3x6	
A4,G7	118	03S44205G25	Screw,T-Tite M4x10	
C2	119	03S44205G03	Screw,T-Tite M3x8	AK
F1	120	03S40012G98	Screw,Tapping M3x8 Flat	AK
D4	RV201	18T56663F01	Volume 50KCx2	
C4	RV202	18T56663F01	Volume 50KCx2	
E5	RV401	18T68333F01	Volume 10KBx2	
E5	RV601	18T56666F01	Volume 250KW	
G3	E1	09T57203F01	Plate,Phono 2P	
G4	E101	09T57203F01	Plate,Phono 2P	
G4	E102	09T57203F02	Plate,Phono 6P	
G4	E103	09T57203F02	Plate,Phono 6P	
F4	E104	09T51101F01	Terminal,SP	
C4	E105	09T56010F01	Jack,Head Phone M1669	
E5	S101-103	40T56653F01	Switch,Push SUN 33	
E5	S104-110	40T56667F01	Switch,Push SUN73	
D4	S301	40T56664F01	Switch,Rotary SRZ	
B2	T1	25T66753F01	Trans Power	SK
		25T67076F01	Trans Power	AK
		25T67306F01	Trans Power	UP
A1	F1	65T42077U17	Fuse Semko T1.25A	
		65T52486F10	Fuse MF61NM3.5-125	UP
D5	L305	65T66752F01	Lamp,Pilot	
E3,F3	Q111a,b	48T47682F02	Transistor 2SC1845 FA	
E4,F5	Q112a,b	48T57130F03	Transistor 2SC3180 O,R	
F4	Q113a,b	48T57129F03	Transistor 2SA1263 O,R	
C4	C1	08T57437F09	Capacitor (Ac) 0.01uF	

# PCB

Pre Main Amp PCB

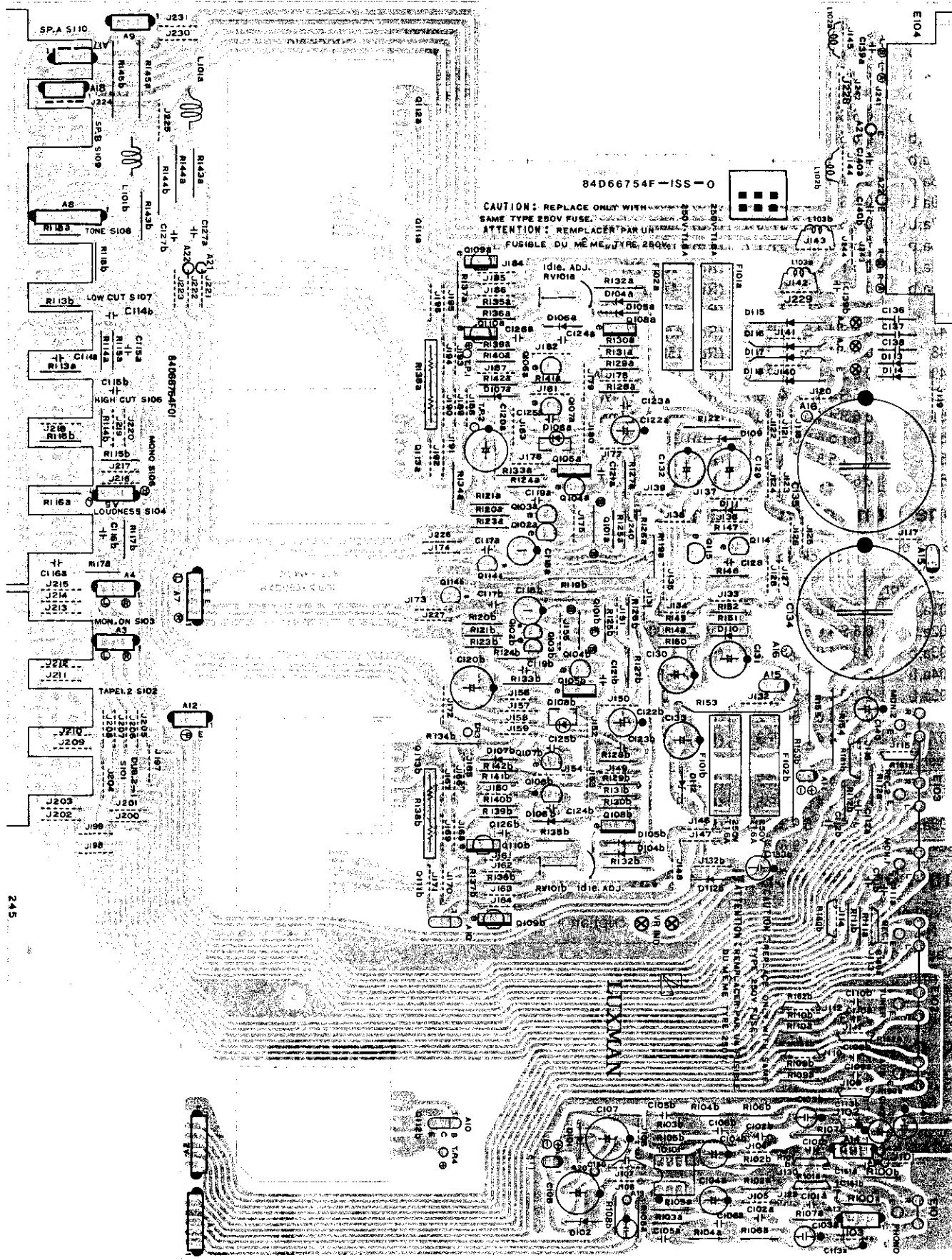

Tone Control PCB

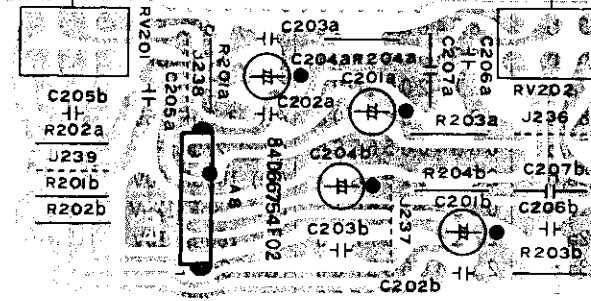

Function SW PCB

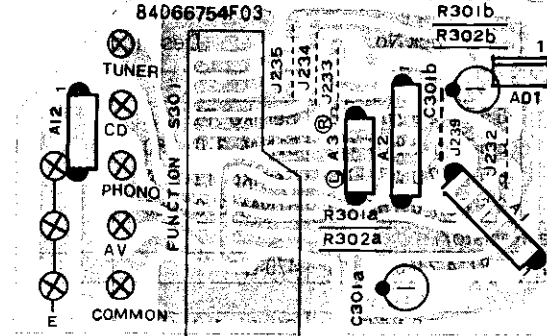

VR Control PCB

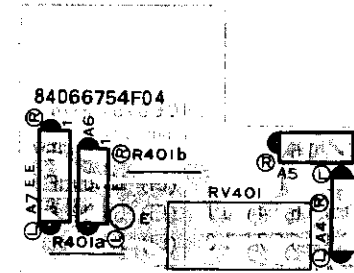

AV Input Terminal PCB

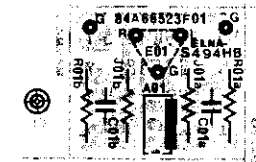

## Destination's Parts List

Symbol No.	Description	SK 220V Europe	AK 220V Europe	UP 120V Canada
9	Plug, SW P-2120	None Use	09T51830F01	None Use
10	Socket, SW M-1615	None Use	09T51831F01	None Use
11	Inlet, 2P	None Use	09T67078F01	None Use
13	Outlet, AC	None Use	None Use	09T57066F01
16	Holder, Fuse	09T51074F01	09T51074F01	09T51828F01
27	Cover, Rear	15D56636F20	15D56636F23	15D56636F28
28	AC Cord	28T43182P02	30T67077F01	28T55335P02
29	Support, Cord	43B41625J02	None Use	43B41625J02
38	Knob, Rotary A	36A66510F01	36A66510F01	36A66510F02
39	Knob, Rotary B	36B66511F01	36B66511F01	36B66511F03
40	Knob, Rotary C	36B66512F01	36B66512F01	36B66512F03
119	Screw	None Use	03S44205G03	None Use
120	Screw	None Use	03S40012G98	None Use
T001	Trans, Power	25T66753F01	25T67076F01	25T67306F01
F001	Fuse	65T42077U17	65T42077U17	65T52486F10
F101a, b	Fuse	65T42077U18	65T42077U18	65T57086F09
F102a, b	Fuse	65T42077U18	65T42077U18	65T57086F09

### Pre Main Amp PCB Parts List

Symbol No.	Stock No.	Description
(Fuse)		
F101a,b	65T42077U18	Semko T1.6 A
F101a,b	65T57086F09	51NM 3.0 -250 (UP)
F102a,b	65T42077U18	Semko T1.6 A
F102a,b	65T57086F09	51NM 3.0 -250 (UP)
(Variable Resistor)		
RV101a,b	18C42061J28	470-B
(Coil)		
L101a,b	24T67516F01	Choke 1.1uH
(IC)		
IC101	51T52153F01	NJM2043D-D
(Transistor & FET)		
Q101a,b	48T53430F01	2SA979-G
Q102a,b	48S43525F05	2SC1815-Y,GR
Q103a,b	48S43525F05	2SC1815-Y,GR
Q104a,b	48S43525F05	2SC1815-Y,GR
Q105a,b	48T56658F01	2SC1904 B,V
Q106a,b	48S43525F02	2SC1815-Y
Q107a,b	48T51118F01	2SA1015-Y
Q108a,b	48T56657F01	2SA899 B,V
Q109a,b	48T56660F03	2SC2824 O,Y
Q110a,b	48T56659F03	2SA1184 O,Y
Q114	48T47682F02	2SC1845 FA
Q114a,b	48T52152F01	2SK30A-GR
Q115	48S43525F05	2SC1815-Y,GR
(Diode & Zener & LED)		
D1	48T51117F01	1S1553
D2	48T51117F01	1S1553
D3	48T51117F01	1S1553
D4	48T51117F01	1S1553
D101	48T52741F54	HZ18 -3L -AX
D102	48T52741F54	HZ18 -3L -AX
D104a,b	48T51117F01	1S1553
D105a,b	48T51117F01	1S1553
D106a,b	48T51117F01	1S1553
D107a,b	48T51117F01	1S1553
D108a,b	48T40955T01	TLR124 RED
D109	48T52741F62	HZ24 -2L -AX
D110	48T51117F01	1S1553
D111	48T44992F01	DS135D
D112a,b	48T52739F87	HZ20 -3
D113	48T44992F01	DS135D
D114	48T44992F01	DS135D
D115	48T51115F02	S3V20(4004)
D116	48T51115F02	S3V20(4004)
D117	48T51115F02	S3V20(4004)
D118	48T51115F02	S3V20(4004)
(Capacitor)		
C101a,b	08T42081U01	(Pp) 100pF
C103a,b	23S40657F11	(EI) 22uF 16V
C104a,b	23T44501P08	(EI) 3.3uF 25V
C105a,b	08S40656F22	(My) 56000pF
C106a,b	08S40656F15	(My) 15000pF
C107	23S41198U42	(EI) 220uF 25V
C108	23S41198U42	(EI) 220uF 25V
C114a,b	23T57007F02	(EI) 0.22uF 50V

Symbol No.	Stock No.	Description
C115a,b	08S40656F10	(My) 5600pF
C116a,b	08S40656F21	(My) 47000pF
C117a,b	08T42081U01	(Pp) 100pF
C118a,b	23T44501P08	(EI) 3.3uF 25V
C119a,b	08S40656F06	(My) 2700pF
C120a,b	23S41198U37	(EI) 100uF 50V
C121a,b	08C42195G15	(St) 33pF 125V
C122a,b	23S40657F08	(EI) 100uF 10V
C123a,b	21S40655F06	(Ce) 5pF
C124a,b	08S40656F05	(My) 2200pF
C125a,b	08S40656F05	(My) 2200pF
C126a,b	08S40656F01	(My) 1000pF
C127a,b	08S40656F21	(My) 47000pF
C128	08S40656F01	(My) 1000pF
C129	23S41198U37	(EI) 100uF 50V
C130	23S40657F35	(EI) 47uF 50V
C131	23S40657F33	(EI) 22uF
C132	23S40657F20	(EI) 47uF 25V
C133a,b	23S40657F26	(EI) 47uF 35V
C134	23T56654F01	(EI) 10000uF 50V
C135	23T56654F01	(EI) 10000uF 50V
C141	23S40657F10	(EI) 10uF 16V
C142	23S40657F10	(EI) 10uF 16V
C143	23S40657F10	(EI) 10uF 16V
(Resistor)		
R1	06S40150T95	(Rd) 18KΩ 1/4W
R2	06S40150T95	(Rd) 18KΩ 1/4W
R3	06S40150T95	(Rd) 18KΩ 1/4W
R4	06S40150T95	(Rd) 18KΩ 1/4W
R102a,b	06S44594P08	(Rd) 56KΩ 1/4W
R103a,b	06S44594P08	(Rd) 56KΩ 1/4W
R104a,b	06S44593P81	(Rd) 4.7KΩ 1/4W
R105a,b	06S44594P38	(Rd) 1MΩ 1/4W
R106a,b	06S44593P29	(Rd) 33Ω 1/4W
R107a,b	06S44593P37	(Rd) 68Ω 1/4W
R108a,b	06S44593P57	(Rd) 470Ω 1/4W
R109a,b	06S44594P38	(Rd) 1MΩ 1/4W
R110a,b	06S44594P38	(Rd) 1MΩ 1/4W
R111a,b	06S44594P38	(Rd) 1MΩ 1/4W
R112a,b	06S44594P38	(Rd) 1MΩ 1/4W
R113a,b	06S44594P38	(Rd) 1MΩ 1/4W
R114a,b	06S44594P38	(Rd) 1MΩ 1/4W
R115a,b	06S44593P75	(Rd) 2.7KΩ 1/4W
R116a,b	06S44593P75	(Rd) 2.7KΩ 1/4W
R117a,b	06S44593P89	(Rd) 10KΩ 1/4W
R118a,b	06S44594P36	(Rd) 820KΩ 1/4W
R119a,b	06S44594P36	(Rd) 820KΩ 1/4W
R120a,b	06S44593P49	(Rd) 220Ω 1/4W
R121a,b	06S44593P49	(Rd) 220Ω 1/4W
R122	06T55177F75	(Rm) 2.7KΩ 1W
R123a,b	06S44594P22	(Rd) 220KΩ 1/4W
R124a,b	06S44593P49	(Rd) 220Ω 1/4W
R125a,b	06S44594P08	(Rd) 56KΩ 1/4W
R126a,b	06S44593P87	(Rd) 8.2KΩ 1/4W
R127a,b	06S44593P57	(Rd) 470Ω 1/4W
R128a,b	06S44593P87	(Rd) 8.2KΩ 1/4W
R129a,b	06S44594P06	(Rd) 47KΩ 1/4W
R130a,b	06S44593P99	(Rd) 27KΩ 1/4W

Symbol No.	Stock No.	Description
R131a,b	06S44593P99	(Rd) 27KΩ 1/4W
R132a,b	06T55175F47	(Rm) 180Ω 1/2W
R133a,b	06T55175F17	(Rm) 10Ω 1/2W
R134a,b	06T55175F27	(Rm) 27Ω 1/2W
R135a,b	06S44593P73	(Rd) 2.2KΩ 1/4W
R136a,b	06S44593P61	(Rd) 680Ω 1/4W
R137a,b	06S55177F55	(Rm) 390Ω 1W
R138a,b	06T51107F01	(Rc) 0.22Ωx2 5W
R139a,b	06S44593P53	(Rd) 330Ω 1/4W
R142a,b	06S44593P53	(Rd) 330Ω 1/4W
R143a,b	06T55175F17	(Rm) 10Ω 1/2W
R144a,b	06T55177F17	(Rm) 10Ω 1W
R145a,b	06T55179F57	(Rm) 470Ω 2W
R146	06S44593P85	(Rd) 6.8KΩ 1/4W
R147	06S44593P33	(Rd) 47Ω 1/4W
R148	06S44593P93	(Rd) 15KΩ 1/4W
R149	06S44594P18	(Rd) 150KΩ 1/4W
R150	06S44594P07	(Rd) 51KΩ 1/4W
R151	06S44594P08	(Rd) 56KΩ 1/4W
R153	06T56661F52	(Rm) 300Ω 3W
R154	06T55179F75	(Rm) 2.7KΩ 2W
R155	06T55179F75	(Rm) 2.7KΩ 2W

### Tone Control PCB Parts List

Symbol No.	Stock No.	Description
(Capacitor)		
C201a,b	23S40657F16	(EI) 4.7uF 25V
C202a,b	08S40656F11	(My) 6800pF
C203a,b	08S40656F20	(My) 39000pF
C204a,b	23S40657F11	(EI) 22uF 16V
C205a,b	21S40655F31	(Ce) 560pF
C206a,b	08S40657F22	(My) 0.056uF
C207a,b	08S44503P30	(My) 0.27uF 50V
(Resistor)		
R201a,b	06S44593P71	(Rd) 1.8KΩ 1/4W
R202a,b	06S44593P53	(Rd) 330Ω 1/4W
R203a,b	06S44593P87	(Rd) 8.2KΩ 1/4W
R204a,b	06S44593P69	(Rd) 1.5KΩ 1/4W

### Function SW PCB Parts List

Symbol No.	Stock No.	Description
(Capacitor)		
C301a,b	23T44501P06	(EI) 2.2uF 35V
(Resistor)		
R301a,b	06S44594P30	(Rd) 470KΩ 1/4W

### VR Control PCB Parts List

Symbol No.	Stock No.	Description
(Resistor)		
R401a,b	06S44593P57	(Rd) 470Ω 1/4W

### AV Input Terminal PCB Parts List

Symbol No.	Stock No.	Description
(Resistor)		
R1a,b	06S40151T38	(Rd) 1.0MΩ 1/4W

### Remarks

Resistor : Rd . . . .Carbon  
 Rf . . . .Frame Proof  
 Rc . . . .Cement  
 Capacitor : EI . . . .Electrolytic  
 Ce . . . .Ceramic  
 My . . . .Mylar  
 St . . . .Styrol  
 Mi . . . .Mica  
 Pp . . . .Polypropylene



## IC Handling Guide

NJM2043D-D  
IC101  
(Stock No. 51T52153F01)

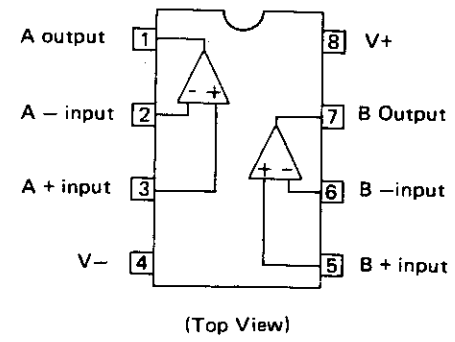

TR, 2SA979G  
Q101a,b  
(Stock No. 48T53430F01)

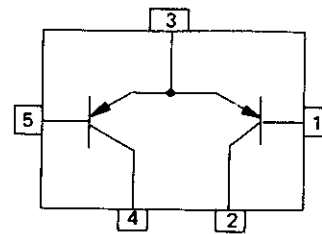

# Schematic Diagram

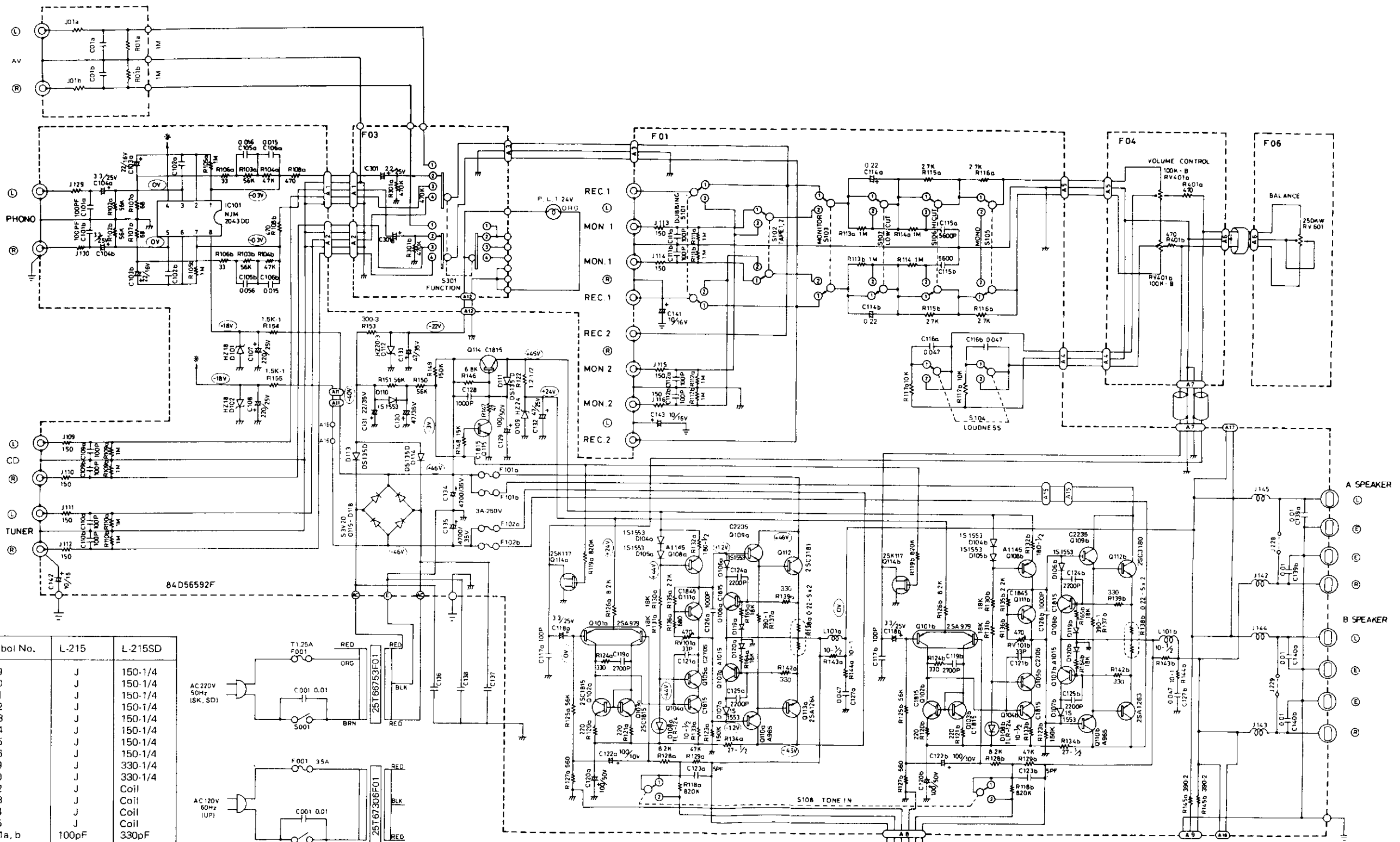

84D56592F

Symbol No.	L-215	L-215SD
J109	J	150-1/4
J110	J	150-1/4
J111	J	150-1/4
J112	J	150-1/4
J113	J	150-1/4
J114	J	150-1/4
J115	J	150-1/4
J116	J	150-1/4
J129	J	330-1/4
J130	J	330-1/4
J142	J	Coil
J143	J	Coil
J144	J	Coil
J145	J	Coil
C101a, b	100pF	330pF
C102a, b	x	2200pF
C109a, b	x	100pF
C110a, b	x	100pF
C111a, b	x	100pF
C112a, b	x	100pF
C113a, b	J	J
C139a, b	x	0.01μ
C140a, b	x	0.01μ
R100a, b	x	x
C136	x	0.01μ
C137	x	0.01μ
C138	x	0.01μ
F101a, b	T1.6A	3A(UP)
F102a, b	T1.6A	3A(UP)

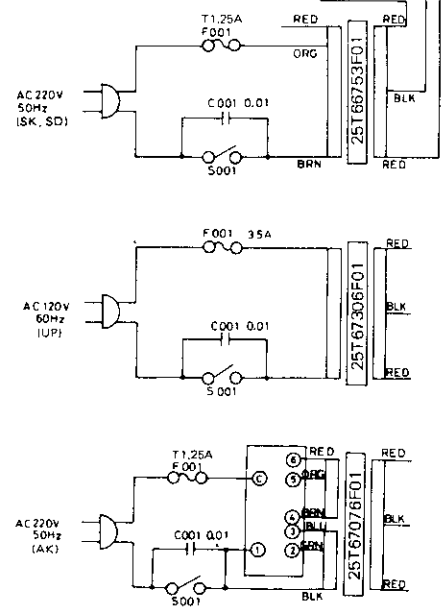

- Remarks**
1. Unless otherwise specified, all resistors are in OHM 1/4 watt, all capacitors in micro farad.
  2. Transistors and diodes may be replaced with any type having comparable ratings.
  3. Due to continued improvements LUX reserve the circuit or specifications.

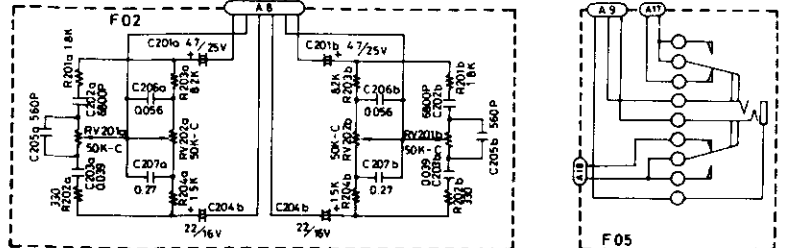
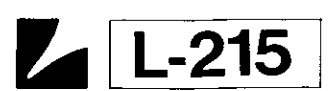

D119a, b 1S1553  
D120a, b 1S1553

## Specifications

Power Output:		
8 ohms, 1KHz		50Wx2
Distortion:		0.02%
Input Sensitivity/Impedance:		
Phono MM		1.8mV/50K ohms
Tuner, Monitor		160mV/40K ohms
AV, CD		160mV/40K ohms
S/N ratio:		
Phono MM (IHF-A weighted, 5mV, Input short)		90dB
Tuner, Monitor (IHF-A weighted)		107dB
AV, CD (IHF-A weighted)		107dB
Residual Noise:		0.5mV
Filter:		
High cut		7KHz(-6dB/oct)
Subsonic		20Hz(-6dB/oct)
Phono MM Overload:		130mV
Frequency Response:		
Phono MM		20Hz~20KHz (±0.5dB)
Tuner, Monitor		10Hz~100KHz (+0, -1.5dB)
AV, CD		10Hz~100KHz (+0, -1.5dB)
Tone Control:		
Treble		±8dB at 10KHz
Bass		±8dB at 100Hz
Loudness (Volume: -3dB)		+8dB at 100Hz
Dimensions:		453(W)x317(D)x111(H) mm (17.8"x12.5"x4.4")
Weight:		
Net		6.3 Kgs
Gross		7.5 Kgs
Power Consumption:		120V 2A (CSA rated)

Specifications and appearance design subject to change without notice.

L-215