

SERVICE MANUAL

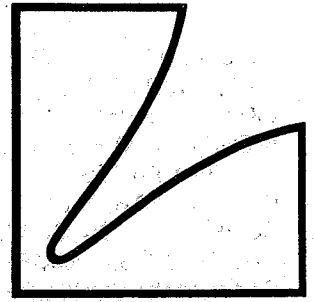

LUXMAN SOLID STATE STEREO
INTEGRATED AMPLIFIER

L-114A

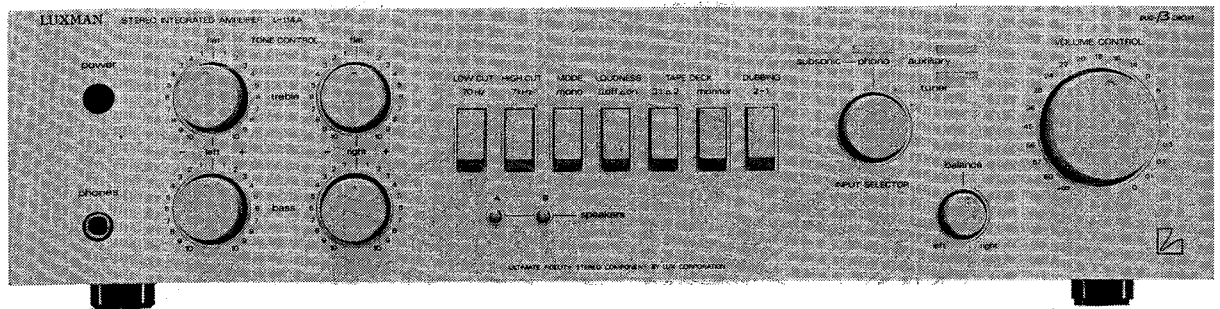

CONTENTS

ALIGNMENT PROCEDURE 1
EXPLODEDVIEW 1
EXPLODEDVIEW PARTS LIST 2
MECHANISM PARTS LIST 3
PB-1324 PARTS LIST 3~5
PB-1345 PARTS LIST 5
SCHEMATIC DIAGRAMME 6
BLOCK DIAGRAMME 7
STANDARD CURVES 7
SPECIFICATIONS 8

ALIGNMENT PROCEDURE

Set up Unit

Volume control: Minimum
Tone Control: Center(Flat)

- 1) Bias (Idle Current) Adjustment
 - (1) Take off Fuse F201 a,b and connect DC Ammeter.
 - (2) Turn ON the Power Switch and wait 1 minute for warm up.
 - (3) Adjust VR201a,b to get 50mA in DC Ammeter.

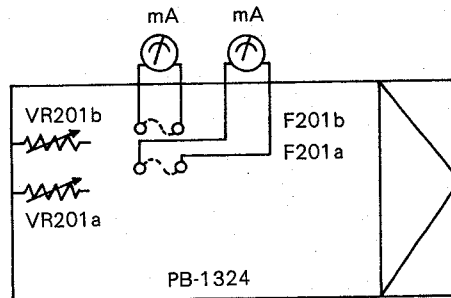

EXPLODED VIEW

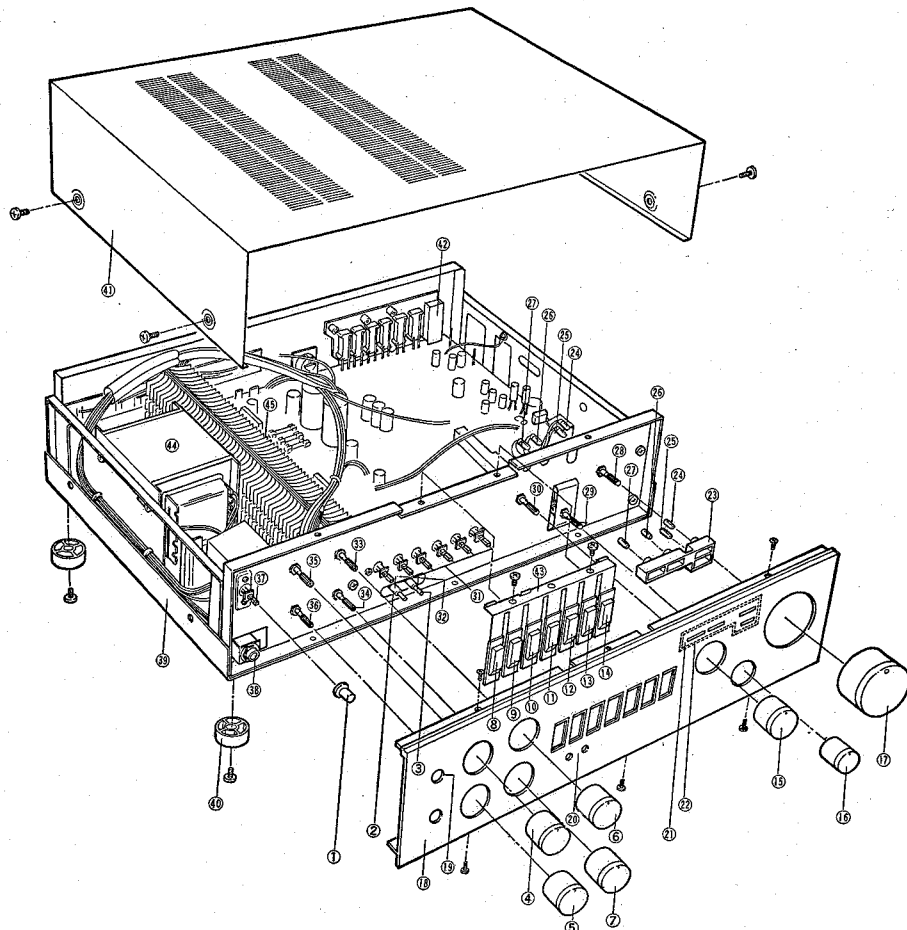

EXPLODED VIEW PARTS LIST

SYMBOL NO.	STOCK NO.	DESCRIPTION	REMARK	SYMBOL NO.	STOCK NO.	DESCRIPTION	REMARK
(Knob)				(Switch, Potentiometer, Jack)			
1	WJ1133	Power Switch		28	RB0258	Volume Cont, 200K Bx2	
2	WJ1145	Speaker, A		29	RV0260	Balance Cont, 250K MN	
3	WJ1145	Speaker, B		30	SR0149	Rotary, Input Selector	
4	WH1117	Treble Control, Left		31	SP0165	Push, Filter-Tape-Mode	
5	WH1117	Bass Control, Left		32	SP0107	Push, Speaker	
6	WH1117	Treble Control, Right		33	RV0267	Treble Cont, 50K C Right	
7	WH1117	Bass Control, Right		34	RV0260	Bass Cont, 50K C Right	
8	WJ1142P	Low Cut		35	RV0260	Treble Cont, 50K C Left	
9	WJ1142P	High Cut		36	RV0260	Bass Cont, 50K C Left	
10	WJ1142P	Mode		37	SP0167	Push, Power	
11	WJ1142P	Loudness		38	AJ0014	Head Phone Jack	
12	WJ1142P	Tape Selector		(Bottom Plate, Foot, Bonnet)			
13	WJ1142P	Monitor		39	UE1105	Bottom Plate 1105	
14	WJ1142P	Dubbing		40	WN0007	Foot	
15	WH1117	Input Selector		*41	UG10281	Bonnet 1028-1	
16	WH1118	Balance Control			UG10282	Bonnet 1028-2	
17	WH1105	Volume Control		(Shield Plate, Switch Spring)			
(Front Panel A'ssy)				42	UK5023	Shield Plate-5023	
18	WA1215	Front Panel 1215		43	UU1032	Switch Spring 1032	
19	WE1089	Protector 1089		(Power Transformer)			
20	WE1095	Protector 1095		*44	PT2521	P-2521	E
21	WE1092	Protector 1092			PT2520	P-2520	S
22	UW1124	Spacer 1124			PT2520B	PT-2520-B	SL
(Lamp, Lamp holder)				(Heat Sink)			
23	UN1025	Lamp holder 1025		45	BE1080	Heat Sink 1080	
24	AL0056	12V75mA (Orange) Aux					
25	AL0056	12V75mA (Orange) Tuner					
26	AL0057	12V75mA (Green) Phono					
27	AL0057	12V75mA (Green) Subsonic					

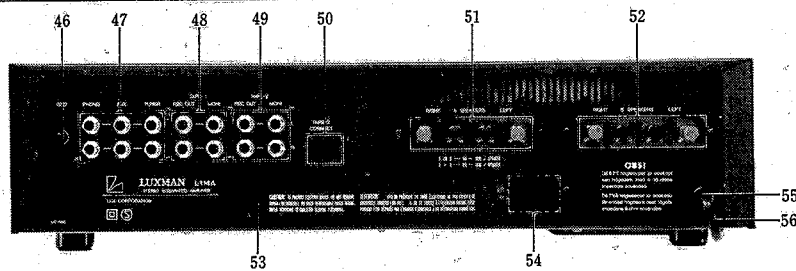

(Terminal)				(Bushing)			
46	AG0120	Ground		*54	AC0010	MD-40	E
47	AT5019	Input 6P, Phono Aux Tuner		(Extra AC Outlet) E Only			
48	AT5018	Input 4P, Tape-1		*55	BU0033	SR-4N-4	SK EK EZ
49	AT5018	Input 4P, Tape-2			BU0039	SR-5N-4	SG SB
50	AS0205	DIN		(Power Cord)			
51	AT0124	Speaker A		*56	BK0022	C2-461-B	EK SK
52	AT0124	Speaker B			BK0018	A-18BF	EZ
(Rear Panel)					BK0023	SAAmini	SG
*53	UC1187	Rear Panel 1187	E		BK0036	SAAmini Plug	SB
	UC1188	Rear Panel 1188	S				

MECHANISM PARTS LIST

SYMBOL NO.	STOCK NO.	DESCRIPTION	REMARK	SYMBOL NO.	STOCK NO.	DESCRIPTION	REMARK
(Line Voltage Selector, E Only)				(Packing material)			
*	AC0014	Plug P-2120	E		XA1274	Carton 1274	
	AC0054	Socket M-1615	E		XB1043	Pad 1043	
(Extension Shaft)				ME0179 Owner's manual			
	UZ1215	Shaft 1215 (Speaker)		(Power Transistor)			
				Q209ab	TR0330	2SC-2577	
				Q210ab	TR0329	2SA-1102	

Notes: In this manual the parts, which differs depending on destination and mains voltage, are classified and indicated as follows:

- E — EK: 220V (With Line Voltage Selector) for Europe, South Asia, East Asia
- EZ: 120V (With Line Voltage Selector) for U.S.A., South Asia, East Asia
- S — SK: 220V for Europe, South East Asia, South America
- SG: 240V for England, Oceania
- SL: 220V for Sweden Only

PB-1324...EQUALIZER POWER AMP

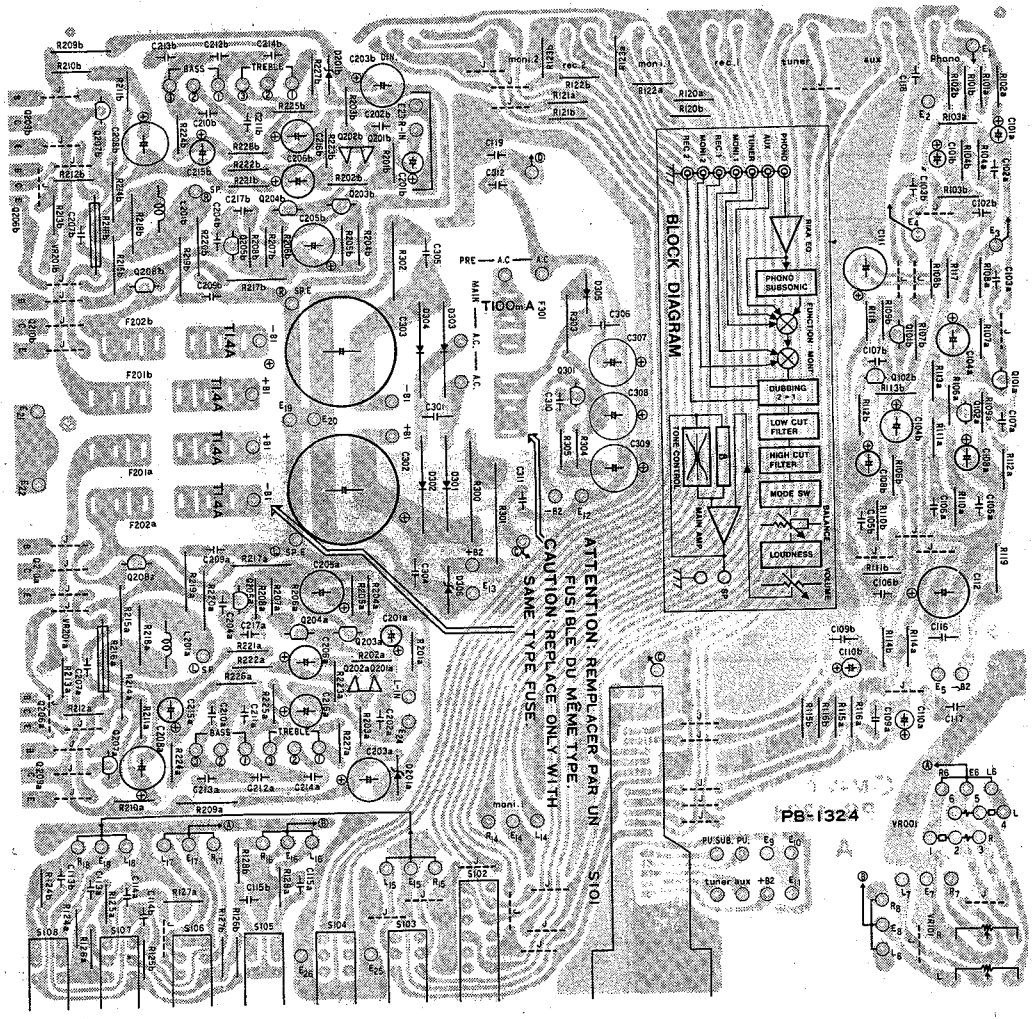

SYMBOL NO.	STOCK NO.	DESCRIPTION			REMARK	SYMBOL NO.	STOCK NO.	DESCRIPTION			REMARK
(Resistor) Unit: Ω						(Capacitor)					
R101ab	RB0414	56K	1/4W	Rd		C101ab	CE0788	3.3 μ F	50WV LR	E1	
R102ab	RB0340	47	1/4W	Rd		C102ab	CC0005	33PF	50WV	Ce	
R103ab	RB0444	1M	1/4W	Rd		C103ab	CC0007	100PF	50WV	Ce	
R104ab	RB0436	470K	1/4W	Rd		C104ab	CE1718	22 μ F	16WV	E1	
R106ab	RB0368	680	1/4W	Rd		C105ab	CQ1427	2000PF	50WV	St	
R107ab	RB0412	47K	1/4W	Rd		C106ab	CQ1441	6800PF	50WV	St	
R108ab	RB0370	820	1/4W	Rd		C107ab	CC0038	5PF	50WV	Ce	
R109ab	RB0420	100K	1/4W	Rd		C108ab	CE1710	47 μ F	10WV	E1	
R110ab	RB0410	39K	1/4W	Rd		C109ab	CQ1325	0.1 μ F	50WV	My	
R111ab	RB0440	680K	1/4W	Rd		C110ab	CE4096	47 μ F	50WV RNB	E1	
R112ab	RB0374	1.2K	1/4W	Rd		C111	CE1721	100 μ F	16WV	E1	
R113ab	RB0394	8.2K	1/4W	Rd		C112	CE1758	100 μ F	50WV	E1	
R114ab	RB0360	330	1/4W	Rd		C113ab	CQ1320	0.039 μ F	50WV	Ce	
R115ab	RB0436	470K	1/4W	Rd		C114ab	CQ1308	3900PF	50WV	Ce	
R116ab	RB0426	180K	1/4W	Rd		C115ab	CQ1319	0.033 μ F	50WV	Ce	
R117	RB0400	15K	1/4W	Rd		C116	CQ1334	1 μ F	50WV	My	
R118	RB0410	39K	1/4W	Rd		C117	CE1717	10 μ F	16WV	E1	
R119	RS1281	100	1/3W	R		C118	CK0158T	0.047 μ F	25WV	Ce	
R120ab	RB0424	150K	1/4W	Rd		C119	CK0158T	0.047 μ F	25WV	Ce	
R121ab	RB0424	150K	1/4W	Rd		C201ab	CE0788	3.3 μ F	50WV LR	E1	
R122ab	RB0424	150K	1/4W	Rd		C202ab	CC0008T	150PF	50WV	Ce	
R123ab	RB0424	150K	1/4W	Rd		C203ab	CE1732	100 μ F	25WV	E1	
R124ab	RB0444	1M	1/4W	Rd		C204ab	CC0006T	47PF	50WV	Ce	
R125ab	RB0444	1M	1/4W	Rd		C205ab	CE1758	100 μ F	50WV	E1	
R126ab	RB0394	6.8K	1/4W	Rd		C206ab	CE1720T	47 μ F	16WV	E1	
R127ab	RB0394	6.8K	1/4W	Rd		C207ab	CK0140T	0.047 μ F	50WV	Ce	
R128ab	RB0398	12K	1/4W	Rd		C208ab	CE1742	47 μ F	35WV	E1	
R201ab	RB0372	1K	1/4W	Rd		C209ab	CQ1321T	0.047 μ F	50WV	My	
R202ab	RB0414	56K	1/4W	Rd		C210ab	CQ1311T	6800PF	50WV	My	
R203ab	RB0396	10K	1/4W	Rd		C211ab	CQ1319T	0.033 μ F	50WV	My	
R204ab	RB0356	220	1/4W	Rd		C212ab	CQ1323T	0.068 μ F	50WV	My	
R207ab	RB0356	220	1/4W	Rd		C213ab	CQ1308	3900PF	50WV	My	
R208ab	RB0374	1.2K	1/4W	Rd		C214ab	CQ1317	0.022 μ F	50WV	My	
R209ab	RS2527L	18K	1/4W	Rd		C215ab	CE1727	4.7 μ F	25WV	E1	
R210ab	RB0382	2.7K	1/4W	Rd		C216ab	CE1718	22 μ F	16WV	E1	
R211ab	RB0390	5.6K	1/4W	Rd		C217ab	CQ1301	1000PF	50WV	My	
R212ab	RB0378	1.8K	1/4W	Rd		C302	CE1023	6800 μ F	45WV	E1	
R213ab	RB0364	470	1/4W	Rd		C303	CE1023	6800 μ F	45WV	E1	
R214ab	RS2512L	100	1/2W	Ro		C304	CQ1334	1 μ F	50WV	My	
R215ab	RS2512L	100	1/2W	Ro		C305	CQ1334	1 μ F	50WV	My	
R216ab	RG0090	0.33	2W	Rc		C306	CK0203	0.01 μ F	500WV	Ce	
R217ab	RS2510L	68	1/2W	Ro		C307	CE1758	100 μ F	50WV	E1	
R218ab	RS2501L	10	1/4W	Rd		C308	CE1758	100 μ F	50WV	E1	
R219ab	RS0117	10	1W	Rf		C309	CE1758	100 μ F	50WV	E1	
R220ab	RS2526L	1.5K	1/2W	Ro		C310	CC0007	100PF	50WV	Ce	
R221ab	RB0412	47K	1/4W	Rd		C311	CK0158	0.047 μ F	25WV	Ce	
R222ab	RB0394	8.2K	1/4W	Rd		C312	CK0158	0.047 μ F	25WV	Ce	
R223ab	RB0346	470	1/4W	Rd		(Diode)					
R224ab	RB0394	8.2K	1/4W	Rd		D201ab	TD0065	WZ-192	ZENER	19.2V	
R225ab	RB0376	1.5K	1/4W	Rd		D301	TD0105	S3V-20			
R226ab	RB0378	1.8K	1/4W	Rd		D302	TD0105	S3V-20			
R227ab	RB0360	330	1/4W	Rd		D303	TD0105	S3V-20			
R300	RS0127	150	2W	Ro		D304	TD0105	S3V-20			
R301	RS5001	180	2W	Ro		D305	TD0003	IN-4003			
R302	RS5060	3.9K	1W	Ro		D306	TD0025	WZ-091	ZENER	9V	
R303	RS2512L	100	1/2W	Ro		(Choke Coil)					
R304	RB0416	68K	1/4W	Rd		L201ab	LA1004	LUX-1004-2M/MH			
R305	RB0372	1K	1/4W	Rd							

SYMBOL NO.	STOCK NO.	DESCRIPTION	REMARK	SYMBOL NO.	STOCK NO.	DESCRIPTION	REMARK
(Transistor)				(Potentiometer)			
Q101ab	TR0320	2SA-992		VR101ab	RBO258	200KΩ Bx2 (C.T)	
Q102ab	TR0323	2SC-1845		(Trimming Potentiometer)			
Q201ab	TR0284	2SA-979-13-G		VR201ab	RT0050	500Ω B KVSF8-7PNFX	
Q203ab	TR0198	2SC-1815		(PCB Fuse Holder)			
Q204ab	TR0198	2SC-1815		*F001	AH0016	X-N1157	E
Q205ab	TR0331	2SC-1438-V			AH0019	X-N1153	S
Q206ab	TR0323	2SC-1845		*F201ab	AH0029	YSH-401T	E
Q207ab	TR0311	2SC-2824			AH0028	23165102-C	S
Q208ab	TR0312	2SA-1184		*F301	AH0029	YSH-401T	E
Q209ab	TR0330	2SC-2577			AH0029	23165102-C	S
Q210ab	TR0329	2SA-1102		(Fuse)			
Q301	TR0320	2SA-992		*F001	BF0077	ULCS-MF61M-2A	EK
(Switch)					BF0080	ULCS-MF61ML-3.5A	EZ
S101	SR0149	Rotary, SWSRS02-64M25KC			BF0236	5x20 1.25A (T)	S
S102				*F201ab	BF0080	ULCS-MF61ML-3.5A	E
S108	SP0165	Push, PSS-72			BF0210	5x20 2A (T)	S
(PCB Board)				*F301	BF0074	ULCS-MF61M-0.5A	E
	PC1324	PB-1324			BF0201	5x20 0.1A (T)	S

PB-1345...SPEAKER SELECTOR

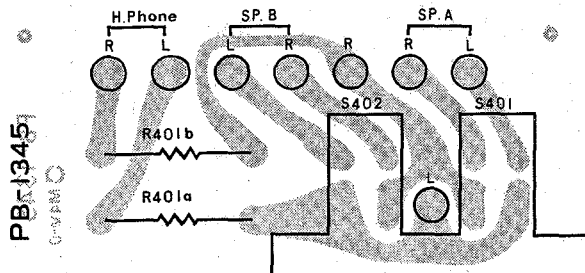

(Resistor)							
R401ab	RS0125	330Ω	2W	Ro			
(Switch)							
SW401ab							
SW402ab	SP0107	Push, 2 key					
(PCB Board)							
	PC1345	PB-1345					

SCHEMATIC DIAGRAMME

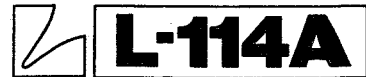
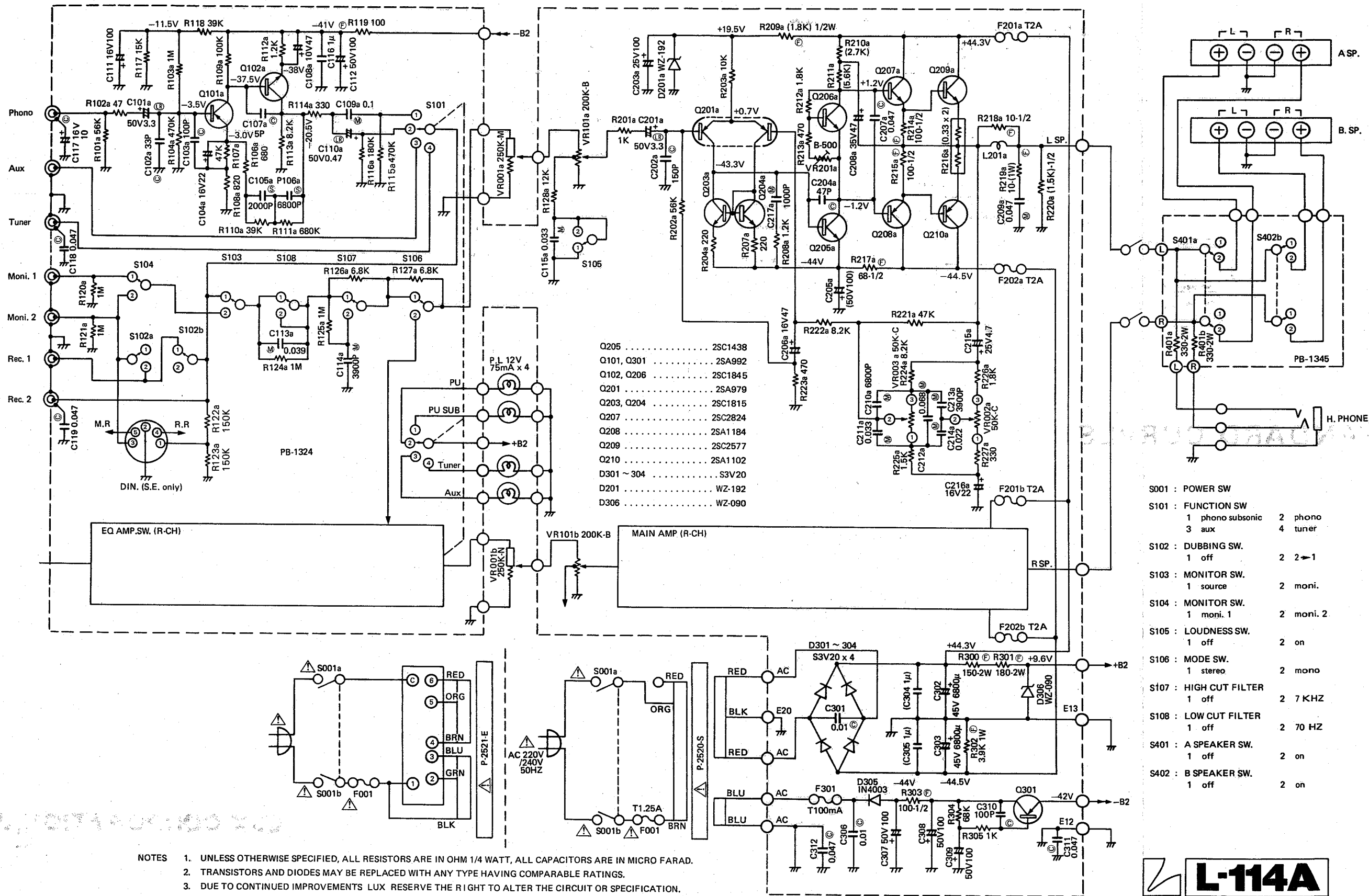

BLOCK DIAGRAMME

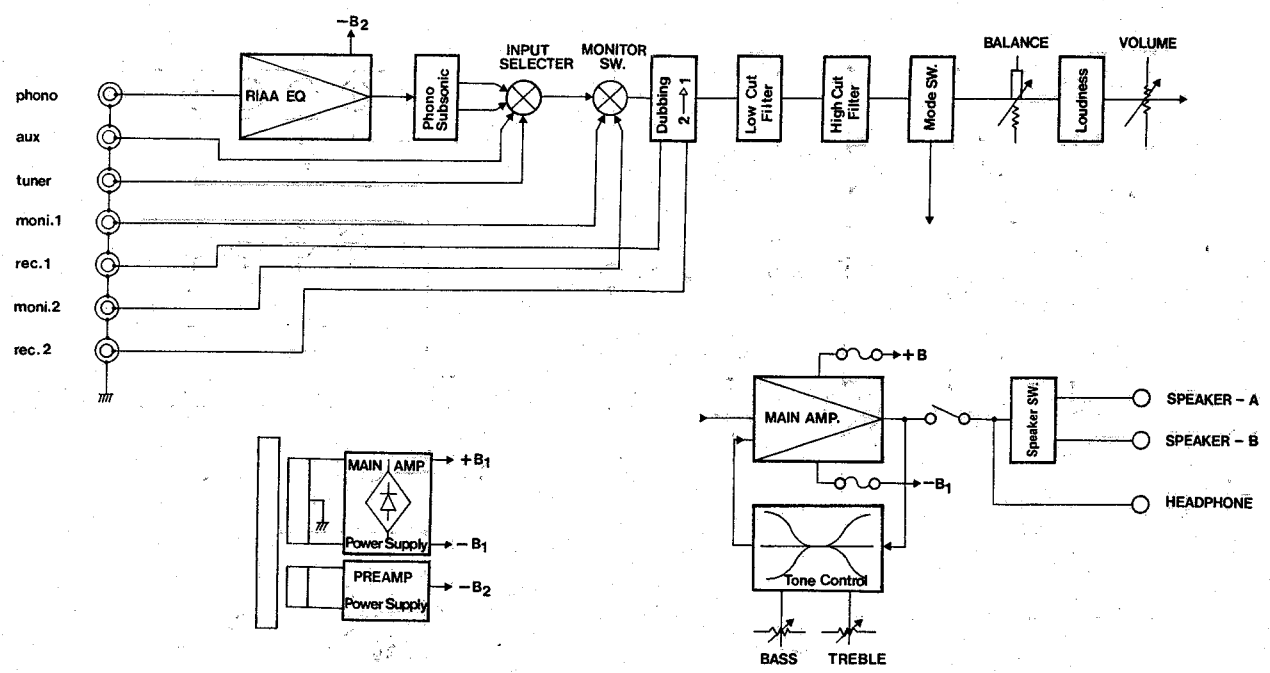

SPECIFICATIONS

Power Output: 48 W per channel both channels driven into 8 ohms with no more than 0.02% total harmonic distortion.

Rated I.M.: no more than 0.02% (8 ohms, 48W/ch, 60 Hz : 7 kHz = 4 : 1)

Frequency Response: 20 Hz ~ 20 kHz (±0.5 dB)—PHONO

Input Sensitivity & Input Impedance:

PHONO	2.5 mV	50 k ohms
TUNER	150 mV	50 k ohms
AUX	150 mV	50 k ohms
MONITOR	150 mV	50 k ohms

Signal-to-Noise Ratio: (input short-circuited)

PHONO	better than 92 dB (IHF-A weighted, 10 mV)
TUNER	better than 100 dB (IHF-A weighted)
MONITOR	better than 100 dB (IHF-A weighted)

Residual Noise: no more than 0.5 mV

Tone Control:

Bass	+ 8 dB	at 70 Hz
	- 10 dB	at 70 Hz
Treble	+8 dB	at 14 kHz
	- 10 dB	at 14 kHz

Filter:

High Cut	7 kHz (-6 dB/oct.)
Phono-Subsonic	30 Hz (-6 dB/oct.)
Low Cut	70 Hz (-6 dB/oct.)

Dimensions: 438(W) x 306(D) x 111(H) mm (17-1/4" x 12-1/16" x 4-13/32")

Weight: Net 8.1 kgs (17.8 lbs.)
Gross 9.3 kgs (20.5 lbs.)

Specifications and appearance design subject to change without notice.

STANDARD CURVES

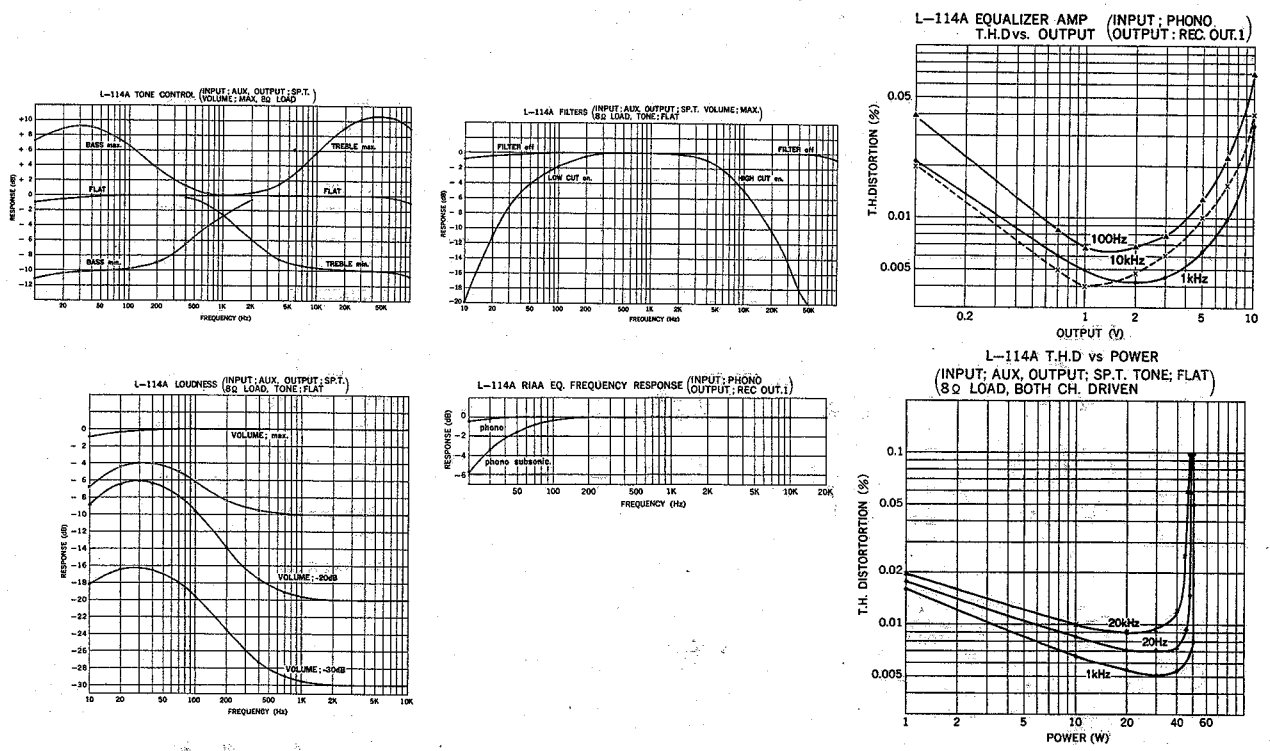

LUX CORPORATION, JAPAN

1-1, 1-CHOME, SHINSENRI-NISHIMACHI, TOYONAKA-SHI, OSAKA
 PHONES: 06-834-0004 CABLE: LUXMAN TOYONAKA TELEX: J63694