

LUXMAN

L 45A

MODEL

SERVICE MANUAL

Exploded View Parts List
Model: L-45A

Symbol No.	Stock No.	Description	Q'ty
1	WB1085	Wooden Case	1
2	YWA40C	Washer, 4ø	4
3	YJB40C20	Screw, M4x20	4
4	AT0080	Terminal, SP	2
5	BU0033	Bush Cord	1
6	BK0015	AC Cord (J)	1
	BK0022	AC Cord (EK)	1
7	AC0050	AC Outlet	2
8	AG0048	Terminal, GND	1
9	UC1185	Rear, Panel	1
10	AT0120	Pin Jack 2P	1
11	AT0122	Pin Jack 4P	3
12	SZ0012	Cable, Remote	1
13	BE1078	Heatsink	1
14	CE1018	Cap., 50V 10,000uF E1	2
15	PT2510	Trans, Power (J)	1
	PT2540	Trans, Power (EK)	1
16	SRO135	SW; Rotary	1
17	SPO037	SW, Power (J)	1
	SPO090	SW, Power (EK)	1
18	WJ1133	Knob, Power	1
21	AJ0014	Jack, HD	1
22	WJ1121	Knob, Lever	6
23	RVO259	VR, 50KCC	1
24	SLO050	SW, Lever	5
25	WJ1136	Knob, Push	1
26	RVO265	VR, 50KCC	1
27	SP0119	SW, Push	1
28	UN1026	Rubber	1
29	ALO060	Lamp (Blue)	1
30	ALO061	Lamp (Green)	1
31	SLO057	SW, Lever	1
32	SRO154	SW, Rotary	1
33	SRO148	SW, Rotary	1
34	RVO257	VR, 8220 (Balance)	1
35	RVO266	VR, 100KBBC.T. (Volume)	1
36	WE1089	Protector	1
37	WD1127	Escutcheon	1
38	WG1011	Pilot	1
39	WG1019	Pilot	1
40	WE1086	Protector	1
41	WH1101	Knob	5
42	WH1100	Knob (Volume)	1
43	WH1102	Knob (Balance)	1
44	WA1213	Panel, Front	1
45	UE1107	Bottom Plate	1
46	WN1019	Foot	4
47	YJB40A20	Screw, M4x20	4
*	ME0204	Owner's Manual (EX)	1
*	MA0135	Owner's Manual (J)	1

Luxman
L 45 A

Exploded View Parts List
Model: L-45A

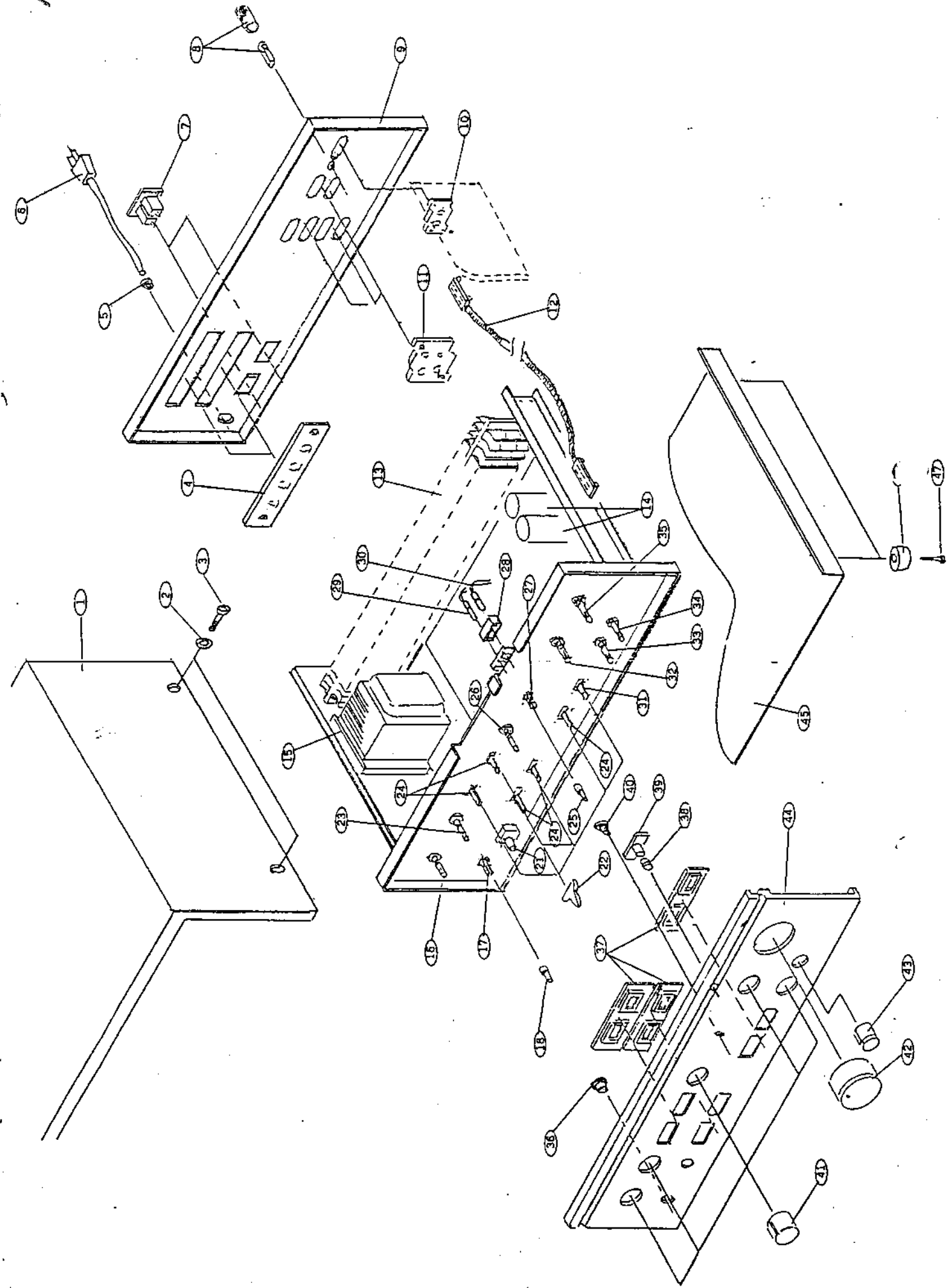

Symbol No.	Stock No.	Description	Q'ty
1	WB1085	Wooden Case	1
2	YWA40C	Washer, 4φ	4
3	YJB40C20	Screw, M4x20	4
4	AT0080	Terminal, SP	2
5	BU0033	Bush Cord	1
6	BK0015	AC Cord (J)	1
	BK0022	AC Cord (EK)	1
7	AC0050	AC Outlet	2
8	AG0048	Terminal, GND	1
9	UC1185	Rear, Panel	1
10	AT0120	Pin Jack 2P	1
11	AT0122	Pin Jack 4P	3
12	SZ0012	Cable, Remote	1
13	BE1078	Heatsink	1
14	CE1018	Cap., 50V 10,000uF E1	2
15	PT2510	Trans, Power (J)	1
	PT2540	Trans, Power (EK)	1
16	SR0135	SW; Rotary	1
17	SPO037	SW, Power (J)	1
	SPO090	SW, Power (EK)	1
18	WJ1133	Knob, Power	1
21	AJ0014	Jack, HD	1
22	WJ1121	Knob, Lever	6
23	RVO259	VR, 50KCC	1
24	SLO050	SW, Lever	5
25	WJ1136	Knob, Push	1
26	RVO265	VR, 50KCC	1
27	SPO119	SW, Push	1
28	UN1026	Rubber	1
29	AL0060	Lamp (Blue)	1
30	AL0061	Lamp (Green)	1
31	SLO057	SW, Lever	1
32	SR0154	SW, Rotary	1
33	SR0148	SW, Rotary	1
34	RVO257	VR, 8220 (Balance)	1
35	RVO266	VR, 100KBBC.T. (Volume)	1
36	WE1089	Protector	1
37	WD1127	Escutcheon	1
38	WG1011	Pilot	1
39	WG1019	Pilot	1
40	WE1086	Protector	1
41	WH1101	Knob	5
42	WH1100	Knob (Volume)	1
43	WH1102	Knob (Balance)	1
44	WA1213	Panel, Front	1
45	UE1107	Bottom Plate	1
46	WN1019	Foot	4
47	YJB40A20	Screw, M4x20	4
*	ME0204	Owner's Manual (EX)	1
*	MA0135	Owner's Manual (J)	1

Luxman
L 45 A

201

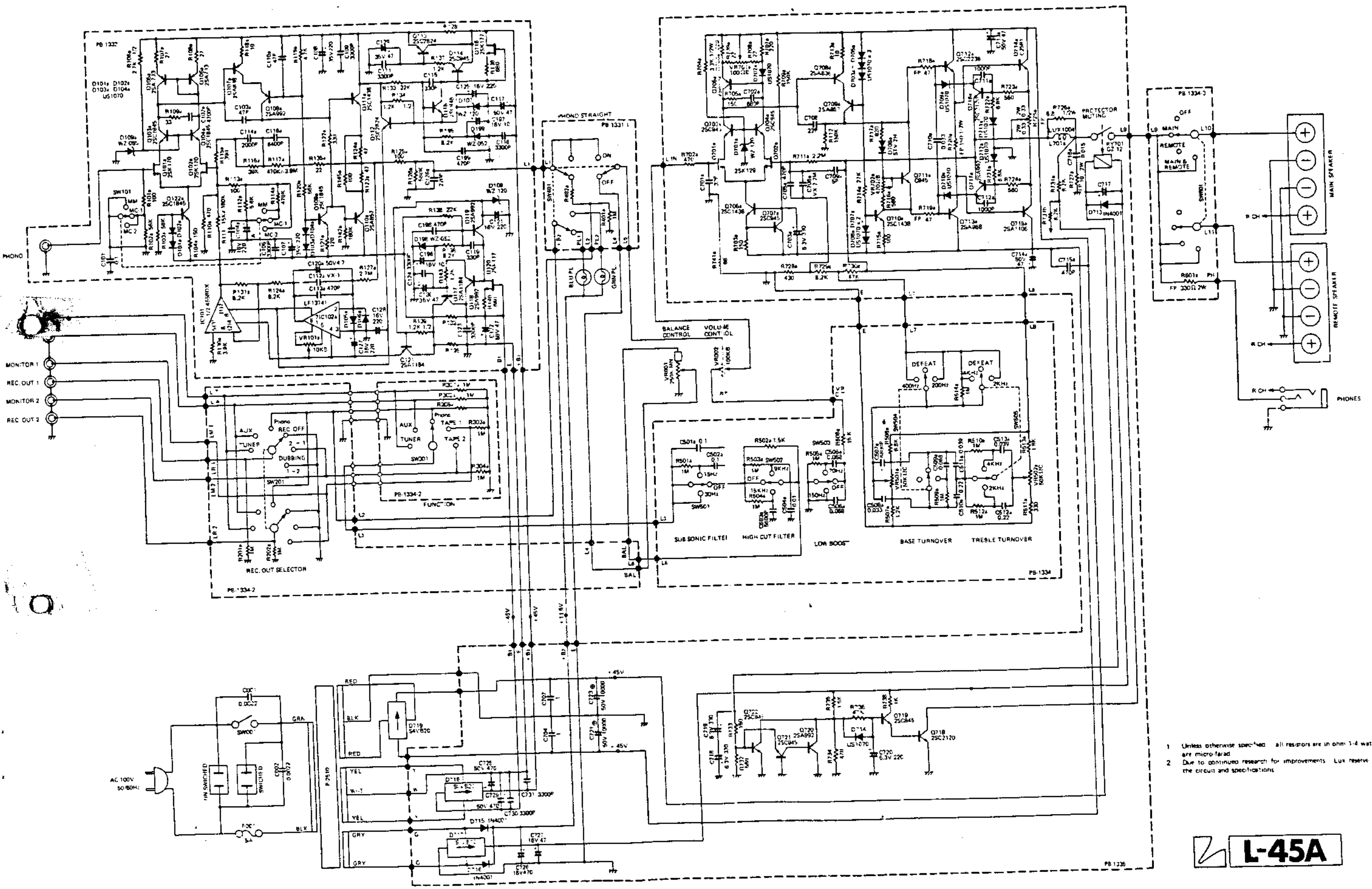

- 1 Unless otherwise specified, all resistors are in ohm 1/4 watt. All capacitors are micro-farad.
- 2 Due to continued research for improvements, Lux reserve the right to alter the circuit and specifications.

L-45A