

SERVICE MANUAL

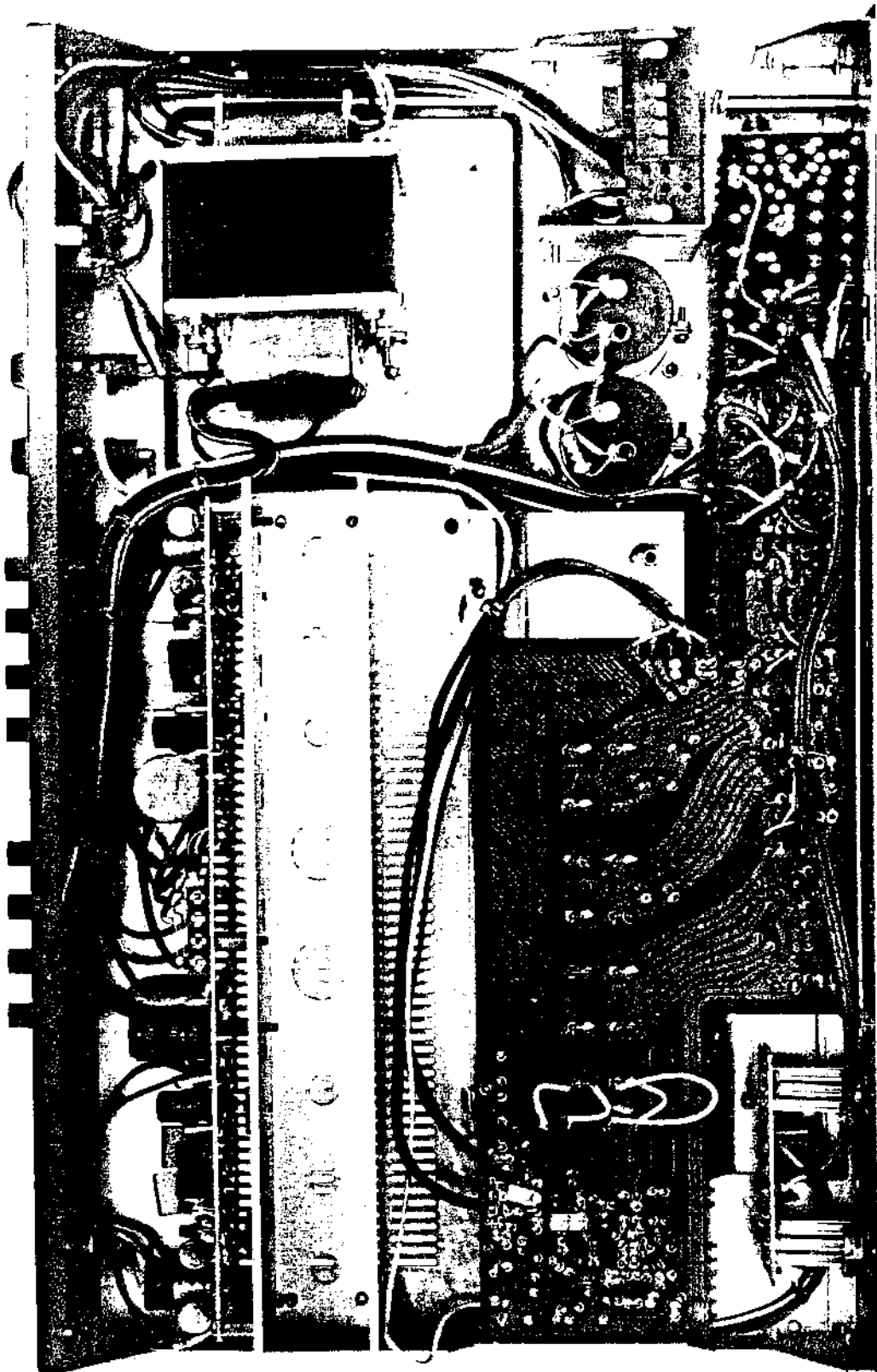

SOLID STATE STEREO
DC INTEGRATED AMPLIFIER **L-5**





Idle Adjustment

- (1) Disconnect 2 pcs of red-core wire of the 2-core shielded wires connected to the plus terminals of electrolytic condenser (10,000UF 55V) from the foregoing terminals.
- (2) Connect a DC amperemeter in between (The electrolytic condenser side should be positive.) the electrolytic condensers and the red-core wires.
- (3) Adjust VR502 and VR402 to obtain 45mA reading on the meter 1 minute after turning the Power Switch on.
- (4) The red-core wires should be soldered again onto the electrolytic condensers after the adjustment.

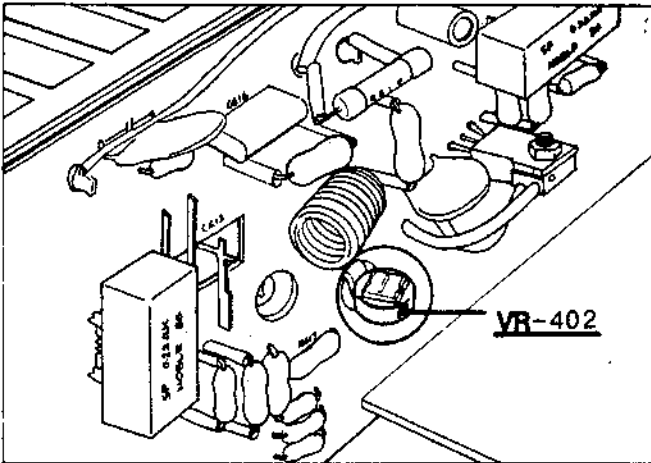
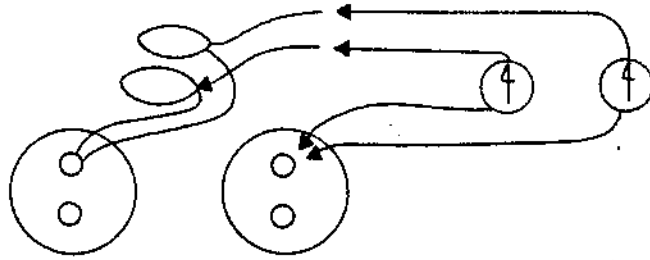

L-ch IDLE ADJUST TRIMMER POT

R-ch IDLE ADJUST

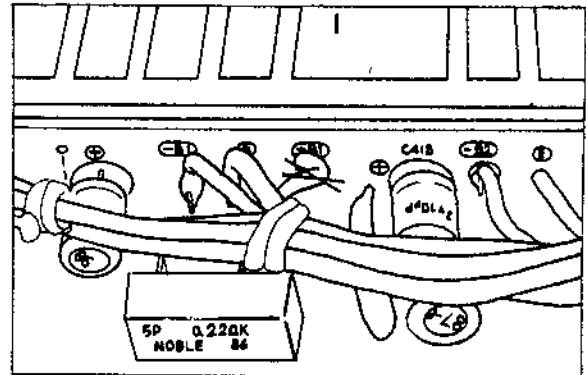

L-ch IDLE ADJUST

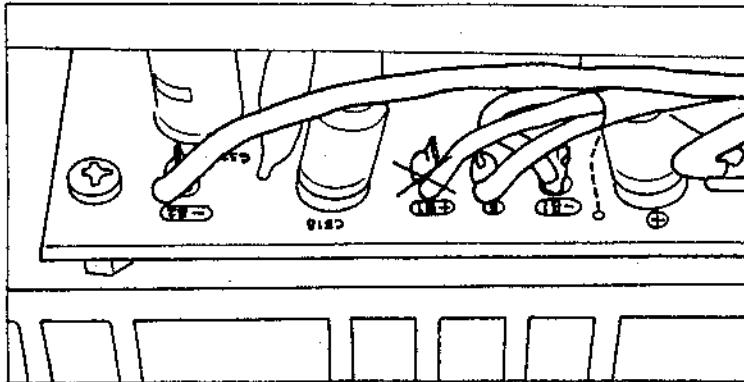

DC Offset Adjustment

- (1) Connect a DC voltmeter (full scale 100 - 300mV) to the speaker terminals on the rear panel.
- (2) Adjust VR401(Lch) and VR501(Rch) respectively to obtain 0V reading on the meter. The two trimmer potentiometer can be found in between the heat sinks and the PB1210(Rch) or the PB1209(Lch).
- (3) This adjustment should be done 1 minute after turning the power on. Note that never remove the heat sinks from the chassis, as otherwise the ground may be floated.

EXPLODED VIEW

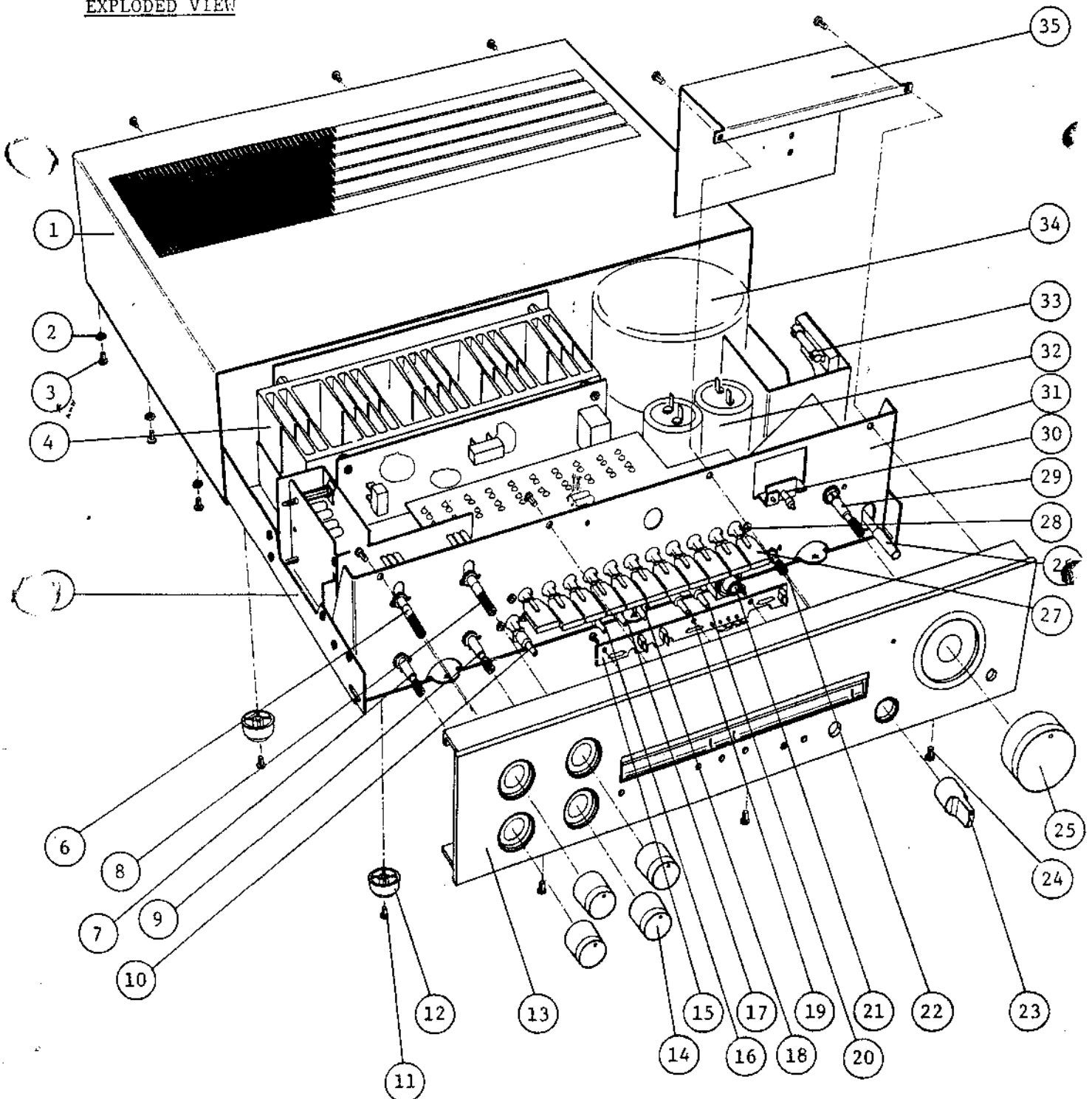

1.	UG1010	Bonnet (S)(E)
	UG1014	" (J)(U)
2.	YWE030B	Washer
3.	YAA30C08	Screw 3x8
4.	BE1060	Heat Sink
	BE1061	" "
5.	UA1056	Chassis
6.	RV0218	Volume 100k-Bx2
7.	SR0108	Rotary Switch SRU2043S
8.	RV0217	Volume 50k-Bx2
9.	SR0108	Rotary Switch SRU2043S
10.	WJ1107	Mould Knob
11.	YJB40A10	Tapping Screw 4x10
12.	WN0007	Leg
13.	WA1181	Panel
14.	WH1080	Knob Set
15.	#P1217	PC-Board Unit
16.	WJ1107	Mould Knob
17.	WJ1107	Mould Knob
18.	WJ1107	Mould Knob
19.	WJ1107	Mould Knob
20.	WJ1107	Mould Knob
21.	AJ0014	Horn Jack LJ264-1-7
22.	RV0205	Volume 250k-MN
23.	WH1079	Knob Set
24.	YAA30A08	Screw 3x8
25.	WH1081	Knob Set
26.	WJ1089	Mould Knob
27.	WJ1106	Mould Knob
28.	SP0106	Push Switch SUF 11-key
29.	RV0223	Volume 200k-Bx2
30.	TD0096	LED, SLC25UR (red)
31.	UB1048	Sub Panel
32.	CE	Electrolytic 10000µF 55V
33.	BF0082	Fuse 5A (U)
	BF0211	" 2.5AT (S)
	BF0116	" 2.5A (EK)
	BF0119	" 5A (EZ)
	BF0119	" 5A (J)
34.	PT2252	Power Trans. P2252 (J)(U)
	PT2253	" " P2253 (S)
	PT2272	" " P2272 (E)

Replacement Parts List

REMARKS

Capacitors: C.....ceramic, E.....electrolytic, M.....mylar, G.....G capacitor
 S.....styrol, T.....tantalum, Mi.....mica, MP.....MP capacitor
 O.....oil capacitor, TRIM.....trimmer capacitor, AC.....AC capacitor
 BP....electrolytic Bi-Polar type

Resistors: ±5%, 1/4W, unless specified otherwise

Type: (S).....model for north European countries
 (U).....model for U.S.A. and CANADA
 (J).....model for JAPAN

PB-1122A

SYMBOL NO.	STOCK NO.	DESCRIPTIONS	SYMBOL NO.	STOCK NO.	DESCRIPTIONS	SYMBOL NO.	STOCK NO.	DESCRIPTIONS
R101ab	RB0224	56k	R107ab	RB0206	10k	R113ab	RD0014	180k
102ab	RD0051	270	108ab	RB0212	18k	114ab	RD0028	15k
103ab	RD0029	12k	109ab	RD0009	470k	115ab	RD0120	2.7k 1/2W
104ab	RB0170	330	110ab	RB0170	330	116ab	RD0056	100
105ab	RB0242	330k	111ab	RB0202	6.8k	117ab	RB0244	390k
106ab	RB0224	56k	112ab	RB0188	1.8k			

SYMBOL NO.	STOCK NO.	DESCRIPTIONS	SYMBOL NO.	STOCK NO.	DESCRIPTIONS
C101ab	CS0006	10uF 16V T	C109ab	CQ0030	4700pF M
102ab	CC0007	100pF C	110ab	CE0078	100uF 16V E
103ab	CE0135	47uF 10V E	111ab	CE0118	47uF 25V E
104ab	CE0135	47uF 10V E	112ab	CQ0138	1uF M
105ab	CE0101	22uF 50V E	113ab	CK0146	0.04uF C
106ab	CC0033	10pF C	114ab	CE0106	22uF 63V E
107ab	CC0007	100pF C			
108ab	CQ0331	0.018uF M			

SYMBOL NO.	STOCK NO.	DESCRIPTIONS
Q101ab	TR0125	2SA836 E
102	TR0125	2SA836 E
103	TR0162	2SA872 E

PB-1209

SYMBOL NO.	STOCK NO.	DESCRIPTIONS	SYMBOL NO.	STOCK NO.	DESCRIPTIONS	SYMBOL NO.	STOCK NO.	DESCRIPTIONS	
R400	RB0148	39k	R419	RB0162	150	R437	RB0198	4.7k	
401	RB0242	330k	420	RS0075	150	438	RB0234	150k	
402	RB0190	2.2k	421	RD0109	56k 1/2W	439	RB0200	5.6k	
403	RB0190	2.2k	422	RS0074	100 1/2W	440	RB0184	1.2k	
404	RB0178	680	423	RS1556	220 1/2W	441	RB0254	1M	
405	RB0190	2.2k	424	RS1556	220 1/2W	442	RB0254	1M	
406	RD0116	6.8k	425	RS1534	10 1/2W	443	RD0129	1.5k 1/2W	
407	RB0222	47k	426	RS1534	10 1/2W	444	RB0218	33k	
408	RB0190	2.2k	427	RS1534	10 1/2W	445	RB0216	27k	
409	RB0214	22k	428	RG0061	0.22 5W	446	RD0129	1.5k 1/2W	
410	RB0216	27k	(U)	RG0073	0.33 5W	447	RD0158	100	
411	RB0208	12k	429	(U)	RG0061	0.22 5W	448	RD0128	1.8k 1/2W
412	RB0190	2.2k	(U)	RG0073	0.33 5W	449	RB0178	680	
413	RS1583	1k 1/2W	430	RS2696	4.7 1W	450	RB0158	100	
414	RB0222	47k	431	RS2709	10 1W	451	RD0128	1.8k 1/2W	
	RD0134	470 1/2W	432	RB0220	39k	452	RB0178	680	
415	-----		433	RB0214	22k				
416	RS0080	270 1/4W	434	RB0198	4.7k				
417	RB0168	270	435	RB0204	8.2k				
418	RD0261	8.2k 1/2W	436	RB0222	47k				

SYMBOL NO.	STOCK NO.	DESCRIPTIONS	SYMBOL NO.	STOCK NO.	DESCRIPTIONS
C401	CE5025	3.3uF 50V E	C416	CQ1062	0.047uF M
402	CE0442	47uF BPE 16V E	417	CK0195	0.01uF 500V C
403	CC0009	220pF C	418	CE0147	10uF 63V E
404	CE0102	47uF 50V E	419	CE0282	47uF BPE 25V E
405	CK0113	1000pF C	420	CE0100	10uF 50V E
406	CK0183	1000pF C	421	CE0078	100uF 16V E
407	QQ0611	0.22uF F	422	CE0118	47uF 25V E
408	CC0002	3.3pF C	423	-----	
409	CC0124	33pF C	424	CE0100	10uF 50V E
410	CE0107	47uF 63V E	425	CE0144	22uF 25V E
411	CK0195	0.01uF 500V C	426	QQ0009	0.047uF M
412	CK0195	0.01uF 500V C	427	QQ0009	0.047uF M
413	CE0106	22uF 63V E	428	CE0076	33uF 16V E
414	CK0195	0.01uF 500V C	429	CE0076	33uF 16V E
415	CE0147	10uF 63V E			

SYMBOL NO.	STOCK NO.	DESCRIPTIONS
RY401	AY0046	GZ12H (relay)
L401	LA1177	6415 (choke coil)

SYMBOL NO.	STOCK NO.	DESCRIPTIONS	SYMBOL NO.	STOCK NO.	DESCRIPTIONS	SYMBOL NO.	STOCK NO.	DESCRIPTIONS
Q401	TR0254	2SA798	Q409	TR0208	2SB648A	Q416	TR0148	2SA826
402	TR0146	2SC1740	410	TR0269	2SC2336	417	TR0264	2SC2235
403	TR0146	2SC1740	411	TR0241	2SA1006	418	TR0146	2SC1740
404	TR0162	2SA872	412	TR0242	2SD745	419	TR0146	2SC1740
405	TR0162	2SA872	413	TR0269	2SB705	420	TR0146	2SC1740
406	TR0207	2SD668A	414	TR0146	2SC1740	421	TR5004	2SC2240
407	TR0207	2SD668A	415	TR0146	2SC1740	422	TR5005	2SA970
408	TR0234	2SC2088						

SYMBOL NO.	STOCK NO.	DESCRIPTIONS	SYMBOL NO.	STOCK NO.	DESCRIPTIONS
D401	TD0141	BZ-340	D408	TD0015	1S1554V
402	TV0020	STV-3H		TD0016	1S1555
403	TV0004	KB-265	409	TD0139	SIVB20
404	TD0002	IN4002	410	TD0015	1S1554V
405	TD0018	1K188FM-1		TD0016	1S1555
406	TD0018	1K188FM-1	411	TD0015	1S1554V
407	TD0015	1S1554V		TD0016	1S1555
	TD0016	1S1555			

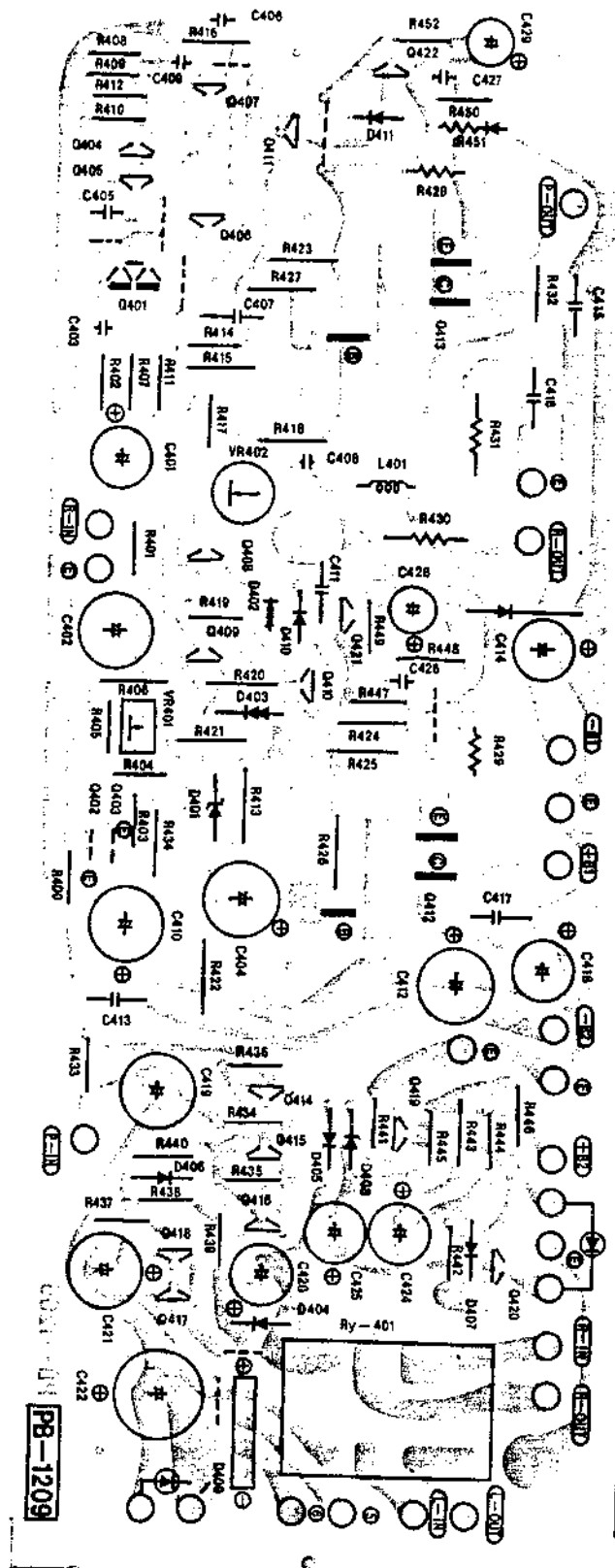

SYMBOL NO.	STOCK NO.	DESCRIPTIONS	SYMBOL NO.	STOCK NO.	DESCRIPTIONS	SYMBOL NO.	STOCK NO.	DESCRIPTIONS
R500	RB0148	39	R521	RB0109	56k 1/2	R536	-----	
501	RB0242	330k	522	RS0074	100 1/2	537	RB0182	1k
502	RB0190	2.2k	523	RS1556	220 1/2	538	RB0192	2.7k
503	RB0190	2.2k	524	RS1556	220 1/2	539	RS5036	180 1W
504	RB0178	680	525	RS1534	10 1/2	540	RB0158	100
505	RB0190	2.2k	526	RS1534	10 1/2	541	RD0128	1.8k 1/2
506	RD0116	6.8k	527	RS1534	10 1/2	542	RB0178	680
507	RB0222	47k	528	RG0061	0.22 5W cement	543	RB0178	680
508	RB0190	2.2k				544	RD0128	1.8k 1/2
509	RB0214	22k		(U) RG0073	0.33 5W	545	RB0158	100
510	RB0216	27k	529	RG0061	0.22 5W cement	R006	RS0094	1k 1W
511	RB0208	12k				VR501	RT0089	500 (B)
512	RB0190	2.2k		(U) RG0073	0.33 5W	502	RT0015	1k(B)
513	RS1583	1k 1/2	530	RS2696	4.7 1W			
514	RB0222	47k	531	RS2709	10 1W			
515	RD0134	470 1/2	532	RB0220	39k			
516	RS0080	270 1/4	533	RB0182	1k			
517	RB0168	270	534	RB0192	2.7k			
518	RD0261	8.2k 1/2	535	RS1535	47 1W			
519	RB0162	150						
520	RS0075	150 1/2						

SYMBOL NO.	STOCK NO.	DESCRIPTIONS	SYMBOL NO.	STOCK NO.	DESCRIPTIONS
C501	CE5025	3.3uF 50V E	C520	CE0107	47uF 63V E
502	CE0442	47uF BPE 16V E	521	CE0079	220uF 16V E
503	CC0009	220pF C	522	CK0142	0.1uF C
504	CE0102	47uF 50V E	523	CE0111	100uF 100V E
505	CE0113	1000pF C	524	CE0111	100uF 100V E
506	CK0183	1000pF C	525	CE0107	47uF 63V E
507	Q00611	0.22uF F	526	CE0079	220uF 16V E
508	CC0002	3.3pF C	527	CE0142	0.1uF C
509	CC0124	33pF C	528	CE0110	47uF 100V E
510	CE0107	47uF 63V E	529	CE0111	100uF 100V E
511	CK0195	0.01uF 500V C	530	-----	
512	CK0195	0.01uF 500V C	531	CK0195	0.01uF C
513	CE0106	22uF 63V E	532	Q00009	0.047uF M
514	CK0195	0.01uF 500V C	533	Q00009	0.047uF M
515	CE0147	10uF 63V E	534	CE0076	33uF 16V E
516	Q01062	0.047uF M	535	CE0076	33uF 16V E
517	CK0195	0.01uF 500V C	L501	LA1177	6415 Choke Coil
518	CE0147	10uF 63V E			
519	CE0147	10uF 63V E			

SYMBOL NO.	STOCK NO.	DESCRIPTIONS	SYMBOL NO.	STOCK NO.	DESCRIPTIONS	SYMBOL NO.	STOCK NO.	DESCRIPTIONS
Q501	TR0254	2SA798	Q511	TR0241	2SA1006	D501	TD0141	BZ-340
502	TR0146	C1740	512	TR0270	D745	502	TV0020	STV-3H
503	TR0146	"	513	TR0269	B705	503	TV0004	KB-265
504	TR0162	A872	514	TR0188	A814	504	TD0143	BZ-240
505	TR0162	"	515	TR0188	"	505	TD0143	BZ-240
506	TR0207	D668A	516	TR5004	C2240	506	TD0068	WZ-240
507	TR0207	"	517	TR5005	A970	507	TD0068	WZ-240
508	TR0234	C2088	D410	TD0015	1S1554V	508	TD0139	SIVB 20
509	TR0208	B648A	411	TD0015	1S1554V	509	TD0139	SIVB 20
510	TR0242	C2336						

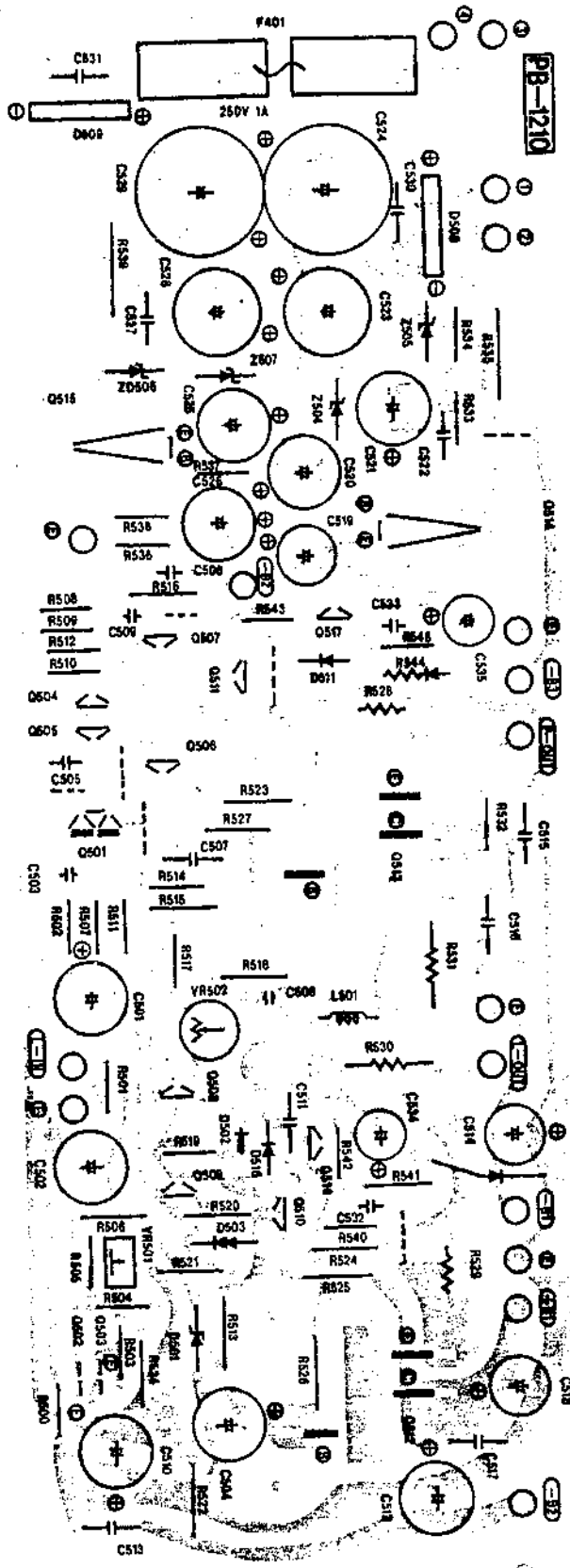

SYMBOL NO.	STOCK NO.	DESCRIPTIONS	SYMBOL NO.	STOCK NO.	DESCRIPTIONS	SYMBOL NO.	STOCK NO.	DESCRIPTIONS
R101ab	RB0254	1M	R106	RB0254	1M	R111	RB0210	17k
102	RB0254	1M	107	RB0254	1M	112	RB0254	1M
103	RB0234	150k	108	RB0202	6.8k	113	RB0180	820
104	RB0234	150k	109	RB0202	"	114	RB0204	8.2k
105	RB0254	1M	110	RB0208	12k	115	RB0254	1M

SYMBOL NO.	STOCK NO.	DESCRIPTIONS	
C101	CK0009	0.1uF	C
102	CK0009	"	C
103	CK0009	"	C
104ab	QQ0612	0.15uF	F
105ab	QQ0009	0.047uF	M
106ab	QQ0330	3300pF	M
107ab	QQ0170	470pF	S
108ab	QQ0031	0.033uF	M

SYMBOL NO.	STOCK NO.	DESCRIPTIONS
SW101-111	SP0118	11-key Push Sw.

SPD108

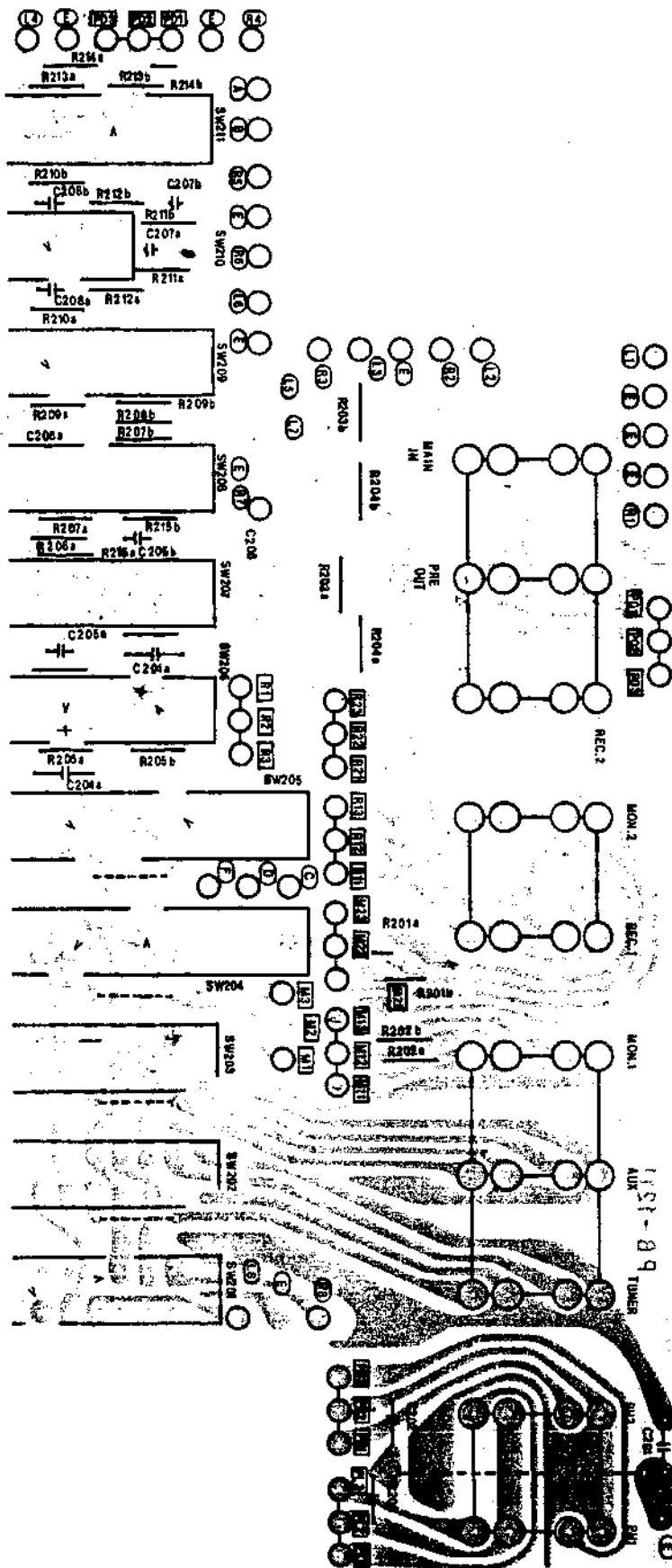

PB-1212

PB1213

SYMBOL NO.	STOCK NO.	DESCRIPTIONS
SW121-123	SP0117	3-key Push Sw.

SYMBOL NO.	STOCK NO.	DESCRIPTIONS
SW131	SP0115	

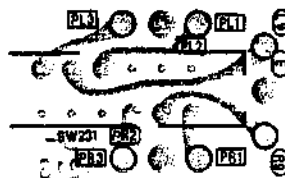
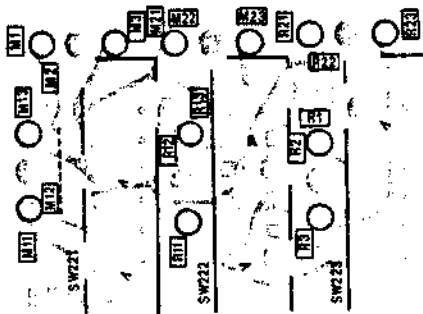

PB-1214

SYMBOL NO.	STOCK NO.	DESCRIPTIONS
R321ab	RB0186	1.5k
322	RB0186	1.5k
323	RB0212	18k
324	RB0212	18k
325	RB0194	3.3k
326	RB0186	1.5k
327	RB0208	12k
328	RB0234	150k
329	RB0206	10k
330	RB0166	220
331	RD0119	3.3k 1/2
332	RB0228	82k

SYMBOL NO.	STOCK NO.	DESCRIPTIONS	
C321ab	CQ0130	1000pF	M
322	CQ0130	"	M
323	CQ0128	2200pF	M
324	CQ0128	2200pF	M
325	CE0173	3.3uF 25V	E
326	CC0037	5pF	C
327	CE0077	47uF 16V	E
328	CE0077	" "	E
329	CE1183	1uF 50V	E
330	CK0145	0.022uF	C
331	CE0107	47uF 63V	E

SYMBOL NO.	STOCK NO.	DESCRIPTIONS
*VR321	RV0217	50k (B) x 2
322	RV0218	100k(B) x 2

SYMBOL NO.	STOCK NO.	DESCRIPTIONS
Q321ab	TR0125	2SA836
322ab	TR0125	2SA836

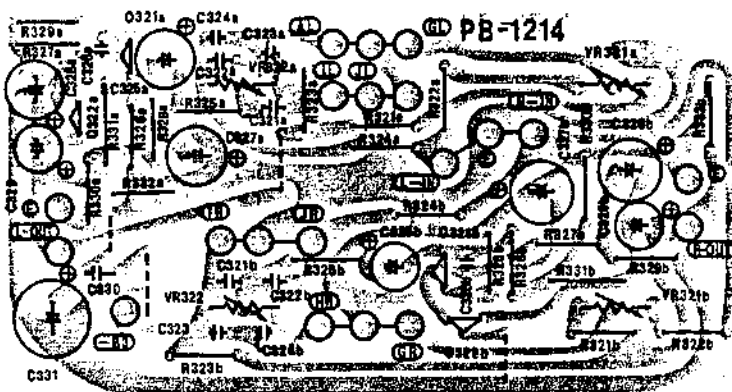

PB-1215

SYMBOL NO.	STOCK NO.	DESCRIPTIONS
R341ab	RB0258	1.5M
342	RB0258	1.5M
343	RB0258	1.5M
344	RB0258	1.5M
345	RB0258	1.5M

SYMBOL NO.	STOCK NO.	DESCRIPTIONS	
C341	CQ0127	3900pF	M
342	CQ0124	0.022uF	M
343	CQ0008	0.056uF	M
SW341	SR0108	SRU 2043S	rotary switch
342	SR0108	"	"

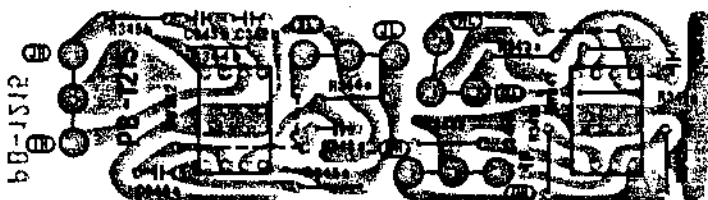

SYMBOL NO.	STOCK NO.	DESCRIPTIONS
SW701	SP0107	2-key push switch
702	SP0107	2-key push switch

SYMBOL NO.	STOCK NO.	DESCRIPTIONS
R601	RD0130	1.2k 1/2
602	RD0129	1.5k 1/2
603	RD0129	1.5k 1/2
D601	TD0134	LED (red)
602	TD0134	"
603	TD0134	"

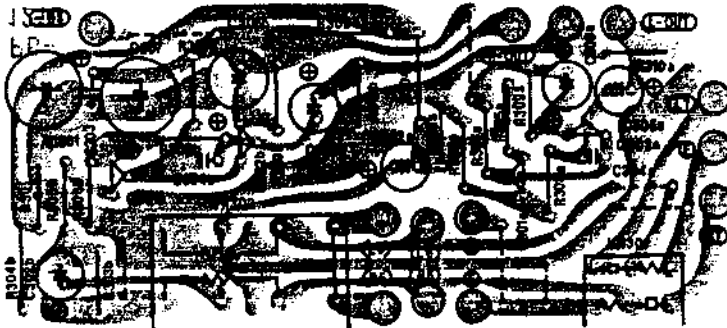

PB-1218

SYMBOL NO.	STOCK NO.	DESCRIPTIONS
R301	RB0206	10k
302	RD0025	27k 1/4
303ab	RB0246	470k
304ab	RD0004	1M
305ab	RB0192	2.7k
306ab	RB0174	470
307ab	RB0212	18k
308ab	RB0196	3.9k
309ab	RB0182	1k
310	RB0242	330k

SYMBOL NO.	STOCK NO.	DESCRIPTIONS
C301	CE0078	100uF 16V E
302ab	CE0173	3.3uF 25V E
303	CK0145	0.022uF C
304ab	CC0012	10pF C
305ab	CE0173	3.3uF 25V E
306ab	CE0077	47uF 16V E
307	CE0167	33uF 63V E

SYMBOL NO.	STOCK NO.	DESCRIPTIONS
Q301ab	TR0125	2SA836
302ab	TR0025	C1345

SYMBOL NO.	STOCK NO.	DESCRIPTIONS
VR301	RV0204	250k MN
302	RV0223	200k(B) x 2

REAR PANEL

STOCK NO.	DESCRIPTIONS
AH0001	Fuse Holder (E) (U)
AH0002	" (U)
AH0018	" (S)
AT0080	SP Terminal
BF0118	Fuse 4A (E)
BF0081	" 4A (U)
BF0213	" 4A(T) (S)
UC1097	Rear Panel (U)
UC1099	" (E)
UC1123	" (UC)
UC1098	" (S)

SUB PANEL

STOCK NO.	DESCRIPTIONS
AJ0014	Headphone Jack
UB1048	Sub Panel

CHASSIS

STOCK NO.	DESCRIPTIONS
WH1047	Knob Set(E) (S)
WH1073	" (E) (S)
WH1074	" (E) (S)
WH1079	" (U)
WH1080	" (U)
WH1081	" (U)
WJ1089	Mould Knob(E) (S)
WJ1106	" 11 pcs
WJ1107	" 6 pcs
WJ1112	" (U)

CHASSIS

STOCK NO.	DESCRIPTIONS
AC0013	AC Selector Socket (E)
AC0014	AC Selector Plug (E)
AH0016	1-P Fuse Holder (E) (U)
AH0019	" (S)
BE1060	Heat Sink
BE1061	Heat Sink
PT2252	Power Trans (U)
PT2253	" (S)
PT2272	" (E)
SP0063	Push Switch (U)
SP0090	" (E) (S)
TD0008	1N4003
TD0110	S5VB40-F
UA1056	Chassis
UG1010	Bonnet (E) (S)
UG1014	Bonnet (U)
WA1135	Front Panel (E) (S)
WA1144	" (U)

