

SERVICE MANUAL

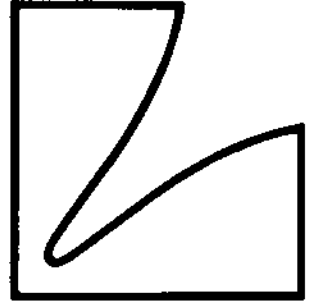

LUXMAN STEREO CASSETTE DECK **K-260**

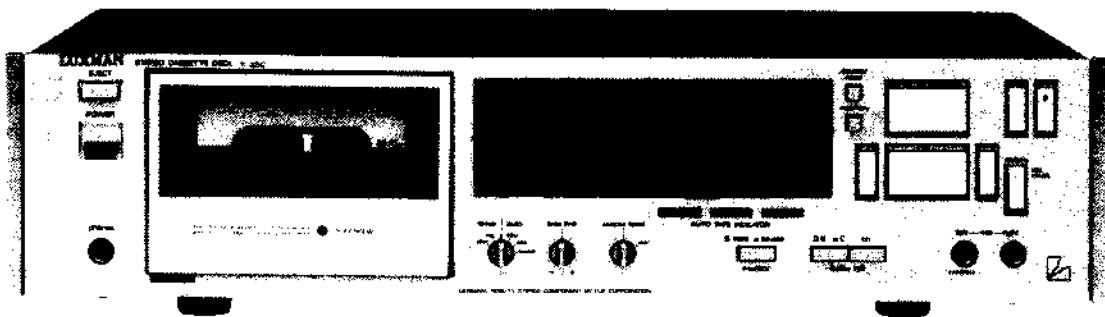

K-260

K-260

Contents

Level Diagram1
Adjustment Location2
Adjustment Procedures	3,4
Exploded View Parts List6
Exploded View (Mech) Parts List8
Packing Material Parts List9
Master PCB Parts List11-15
Key Board Switch PCB Parts List15
Memory and Reset PCB Parts List16
Rotary Switch PCB Parts List16
FL Meter PCB Parts List17
Indicator PCB Parts List17
Control PCB Parts List18
Power Supply PCB Parts List19
Head Phone PCB Parts List19
Destination's Parts List19
Schematic Diagram(A)20
Schematic Diagram(B)21
IC Handling Guide22
Specification23

Level Diagram

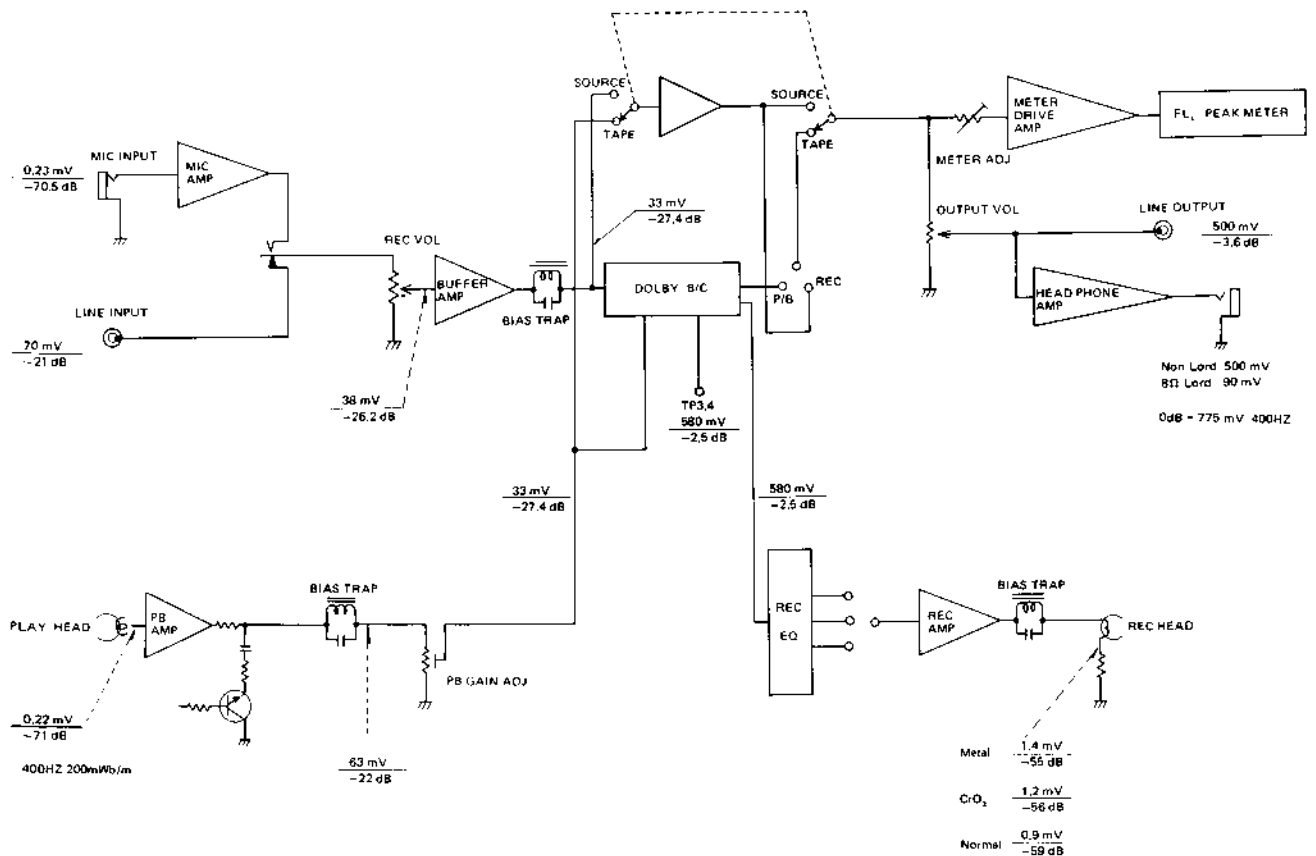

K-260



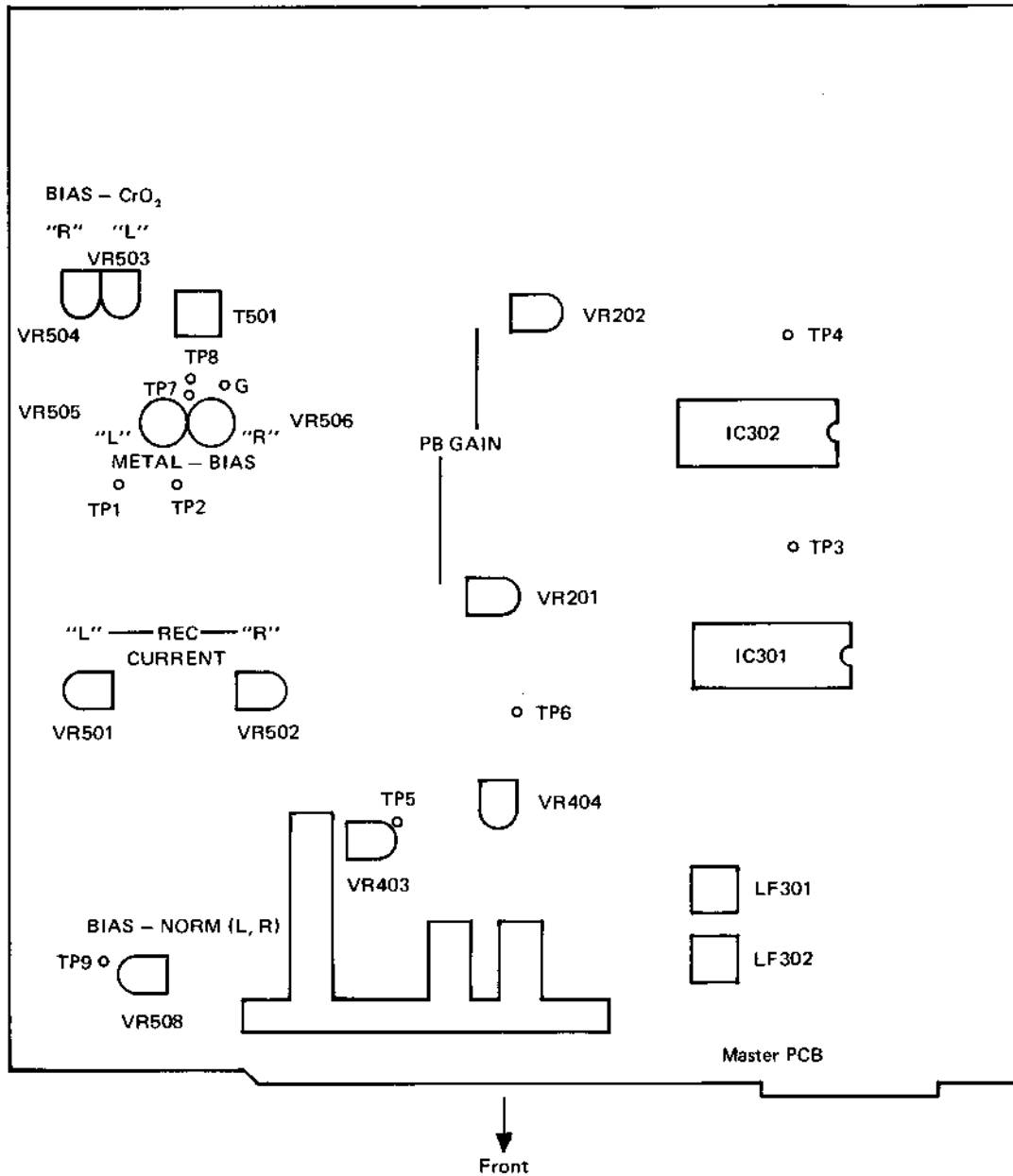

Adjustment Locations

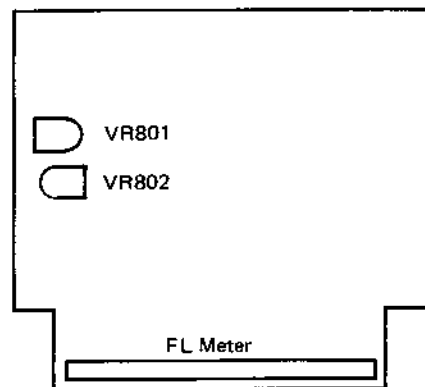

- | | | |
|----------------|----------------------------|----------|
| VR201; 22KB | P/B Gain Adj; | (L-ch) |
| VR202; 22KB | P/B Gain Adj | (R-ch) |
| VR403; 10KB | Source MON | (L-ch) |
| VR404; 10KB | Source MON | (R-ch) |
| VR501; 47KB | REC Level Adj | (L-ch) |
| VR502; 47KB | REC Level Adj | (R-ch) |
| VR503; 100KB | Bias Adj. CrO ₂ | (L-ch) |
| VR504; 100KB | Bias Adj. CrO ₂ | (R-ch) |
| VR505; 100KB | Bias Adj. Metal | (L-ch) |
| VR506; 100KB | Bias Adj. Metal, | (R-ch) |
| VR508; 2.2KB | Bias Adj. Normal | (L/R-ch) |
| VR801; 4.7KB | Meter Adj | (L-ch) |
| VR802; 4.7KB | Meter Adj | (R-ch) |
| T501; Bias OSC | Frequency Adj | |

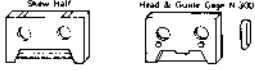

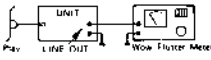
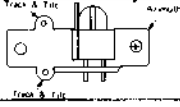
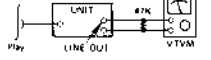
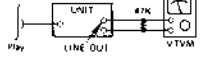
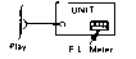
Adjustment Procedures

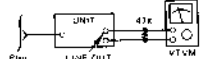
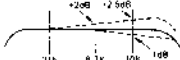
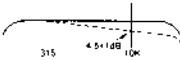
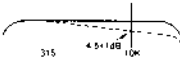
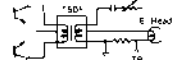
Step	Description	Mode	Adjusting Point	Test Point	Connection	Remarks
1	Tape Transportation Check	Play				Make sure that does not the tape guide of erase and R/P heads, by using "Skew Half". Confirm that R/P head is placed without any tilt against the "MM-300" gage.
2	Torque Check	Play, FF & Rew				Take Up Torque : 35-60 g. cm Back Tension Torque : 2-6 g. cm FF & Rew Torque : 70-130g. cm
3	Tape Speed and Wow Flutter Check	Playback		Line Out		Test Tape : MTT-111 (3KHz) Speed : 3000Hz±1.5% Adjust to read 3005~3015Hz at the begining of tape take up Wow Flutter : No more than 0.05% (JIS W.R.M.S.)
4	Head Azimuth Adjustment	Playback				Test Tape : MTT-114 (10KHz) or MTT-215C (315Hz, 10KHz) Line Out : Maximum of both channel
5	Playback Dolby Level Adjustment	Playback Tape Select : Normal Dolby NR : Off	VR201 Lch VR202 Rch	TP3. 4		Test Tape : MTT-150 (400Hz, 200nWb/m) TP3. 4 : 580mV
6	FL Meter Adjustment	Playback	VR801a Lch VR801b Rch	Meter Display		 Test Tape : MTT-150 Meter Display : 0 dB
7	Playback Frequency Response Check	Playback Tape Slect : Normal Dolby NR : Off	Step 1-5	Line Out		 Test Tape : MTT217L or MTT-215C
		Playback Tape Select : CrO ₂ Dolby NR : Off				 Test Tape : MTT-114 or MTT-215CC
		Playback Tape Slect : Metal Dolby NR : Off				
8	Bias OSC Frequency Check	Record Tape Select : Metal Dolby NR : Off	T501	Erase Current TP7-TP8(GND)		Input : Non Tp Output : 105KHz±5KHz 260mV±20mV

Step	Description	Mode	Adjusting Point	Test Point	Connection	Remarks	
9	a Bias Current Adjustment	Record Tape Select : Metal Dolby NR : Off	VR505 Lch VR506 Rch	TP1, TP2 GND		Input : Non TP Output : 9mV	
	b Record Tape Select : CrO Dolby NR : Off	Record Tape Select : CrO ₂ Dolby NR : Off	VR503 Lch VR504 Rch				Input : Non TP Output : 6mV
	c	Record Tape Select : Normal Dolby NR : Off	VR508 L/Rch			Input : Non TP Output : 5mV	
10	a Input Level Adjustment	Record Tape Select : Normal Dolby NR : Off	Rec Level VR	Line Out		Input : 70mV 400Hz Line Out : 550mV	
	b	Source Monitor	VR403 Lch VR404 Rch	TP5, 6	TP		Input : 70mV 400Hz TP5, 6 : 580mV
11	a Record Level Adjustment and Check	Record/play Tape Select : CrO ₂ Dolby NR : Off	VR501 Lch VR502 Rch			Input : 70mV 400Hz Line Out : 500mV	
		Record/Play Tape Select : Normal Dolby NR : Off	Chek				
		Record/Play Tape Select : Metal Dolby NR : Off	Chek				
12	a Record/Playback Frequency Response Check	Record/Play Tape Select : Metal Dolby NR : Off	Step 8-11				Record Tape : AC-711 Input : 20Hz-18KHz 4.0mV
		Record/Play Tape Select : CrO ₂ Dolby NR : Off					Record Tape : AC-512 Input : 20Hz-17KHz 4.0mV
		Record/Play Tape Select : Normal Dolby NR : Off					Record Tape : AC-223 Input : 20Hz-16KHz 4.0mV
13	Record/Playback Frequency Response Check Dolby	Record/Play Tape Select : M, C, N Dolby NR : B, C					Record Tape : AC-711, AC-512 AC-223 Input : 20Hz-12.5KHz 4.0mV

※Caution on the Adjustment.

The K-260 is composed of 3-head/single dolby circuitry, and therefore at reproduces sound with dolby-encoded at the rec/play monitor output terminal.
While the originally flat frequency response can be obtained only when the tape is reproduced after intended complete recording.

LUX K-260
EXPLODED VIEW

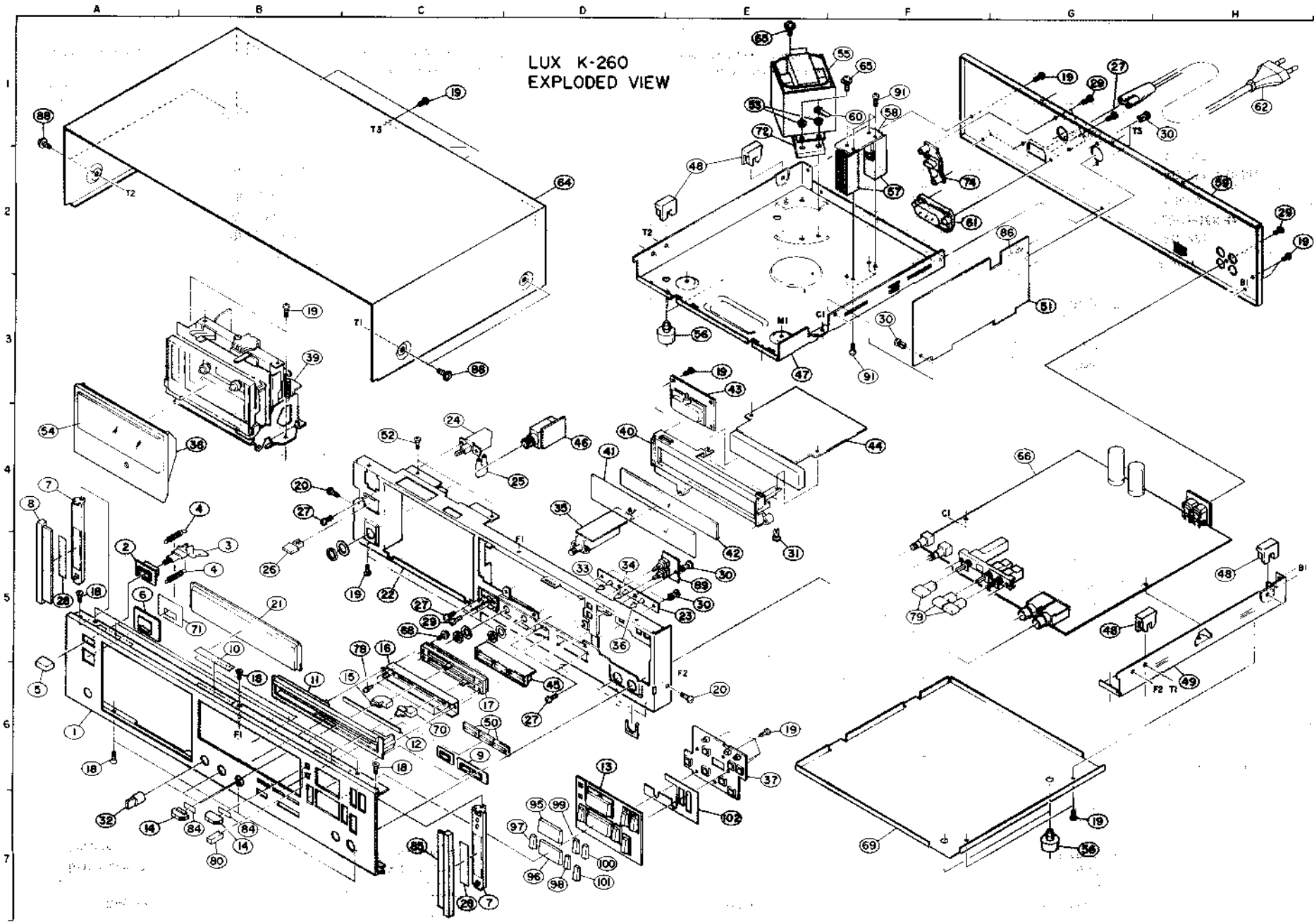

Exploded View

Exploded View Parts List

Index	Symbol No.	Stock No.	Description	Index	Symbol No.	Stock No.	Description
A6	1	64D61259F01	Panel, Front	D6	45	43A61328F01	Bush, Lamp
A5	2	07A45558F04	Frame, Eject	D4	46	01V61900F13	Ass'y, Head Phone PCB
B5	3	45A50461F01	Lever, Eject	E3	47	27D58921F02	Chassis, Bottm
B4,B5	4	41A45559F01	Spring, Eject	E2,G5	48	07A61143F01	Spacer, Side
A6	5	36A44340F05	Knob, Eject	H6	49	27C58922F01	Chassis, Side
A5	6	61A56641F01	Crystal, IND	C6	50	01A61141F01	Lens Indtcator
A4,C7	7	07A57175F01	Bkt, side Panel	G3	51	01V61900F32	Ass'y, Control PCB
A4	8	07B56624F01	Frame, Side Panel	C4	52	03S44205G16	Screw, T—Tite M3×6
C6	9	07A61138F01	Frame, Push Knob	A4	54	61C57187F01	Crystal, Door
B5	10	75B44032G04	Pad, Cushion	E1	55	25T60094F01	Trans, Power
B6	11	13C57168F03	Escutcheon, VR	E3,G7	56	75A60070F01	Ass'y, Pad Rubber
C6	12	43A57191F01	Spacer, Escu	F2	57	07T56351F02	Heat Sink
D6	13	07C57172F01	Frame Knob Logic	F1	58	01V63100F35	Ass'y, Power PCB
A7,B7	14	36B57177F01	Knob, Control	H2	59	15C58925F04	Cover, Rear
C6	15	43B57179F01	Spacer Konb, Con B	F1	60	29A41814F01	Lug
C5	16	07B57169F01	Bkt, Slide Volu, me	F2	61	09T60095F01	Socket, AC
C6	17	18T52629F01	Volume, Slide 20K	H1	62	30T60805F01	Cord, Set (200V)
A5,A7	18	03S40012G26	Screw, M3×6			30T60804F01	Cord Set (120V)
B3,C1	19	03S40012G48	Screw, M3×6			30T60973F01	Cord Set (240V)
B4,E6	20	03S40012G08	Screw, M4×6	D2	64	15D61137F01	Cover, Top
B5	21	61B57170F01	Cryatal, Meter	E1	65	03S40036U16	Screw, M4×6
C5	22	27D61136F01	Chassis, Front	G4	66	01V61900F12	Ass'y, Master PCB
E5	23	01V61900F40	Ass'y, Indicator,PCB	C5	68	03S40018G02	Screw, TPG M3×8
C4	24	40T45561F02	Switch, Power	F7	69	15C58924F01	Cover, Bottom
D4	25	43T53136F01	Bush, Cap	C6	70	43B57178F01	Spacer, Knob Cont (A)
B5	26	36A56639F02	Knob, Power	B5	71	43A56628F01	Spacer, Power
A4,C5	27	03S40012G08	Screw, M4×6	F2	74	09T57205F01	Plate, Phono
A5,C7	28	14S53018F52	Insulator 50×12	C5	78	03C40014G12	Screw, M2.6×4
C5,G1	29	03S40012G41	Screw, M3×8	F5	79	36A57176F01	Knob, Push (A)
E5	30	05B41635J02	Rivet, Push	B7	80	36A57180F01	Knob, Push (B)
E5	31	05B41635J03	Rivet, Push	B2	84	75A57370F01	Pad, Cushion
A7	32	36B51053F02	Knob, Rotary	C7	85	07B56624F02	Frame, Side Panel
D5	33	43A41728U15	Bush, Lamp	G2	86	09T50261F01	Jack Cont
D5	34	43A41728U14	Bush, Lamp	A1,B3	88	03S40036U07	Screw, M4×12
D4	35	01V61900F20	Ass'y, Rotary SW PCB	E5	89	01V61900F21	Ass'y, Memory & Reset
D5	36	43A41728U11	Bush, Lamp	F1,F3	91	03S40011G17	Screw, M3×6
E6	37	01V61900F26	Ass'y, Key Board SW	D7	95	36B57173F01	Knob, Logic (Play)
B4	38	64B57188F01	Plate, Door	D7	96	36B57173F02	Knob, Logic (Stop)
B3	39	01U62000F37	CAS Deck FL87E32H	D7	97	36A57174F01	Knob, Logic (FF)
D4	40	07C57182F01	Frame, Meter	D7	98	36A57174F02	Knob, Logic (REW)
D4	41	61A57183F01	Folter, Meter (A)	D7	99	36A57174F03	Knob, Logic (Pause)
E5	42	61A57220F01	Filter, Meter (B)	D7	100	36A57174F04	Knob, Logic (REC)
E3	43	01V63400F11	Ass'y, FL Counter	D7	101	36A57174F05	Kuob, Logic (Mute)
F4	44	01V61900F19	Ass'y, FL Meter	E7	102	07A57192F01	Bracket, Stopper

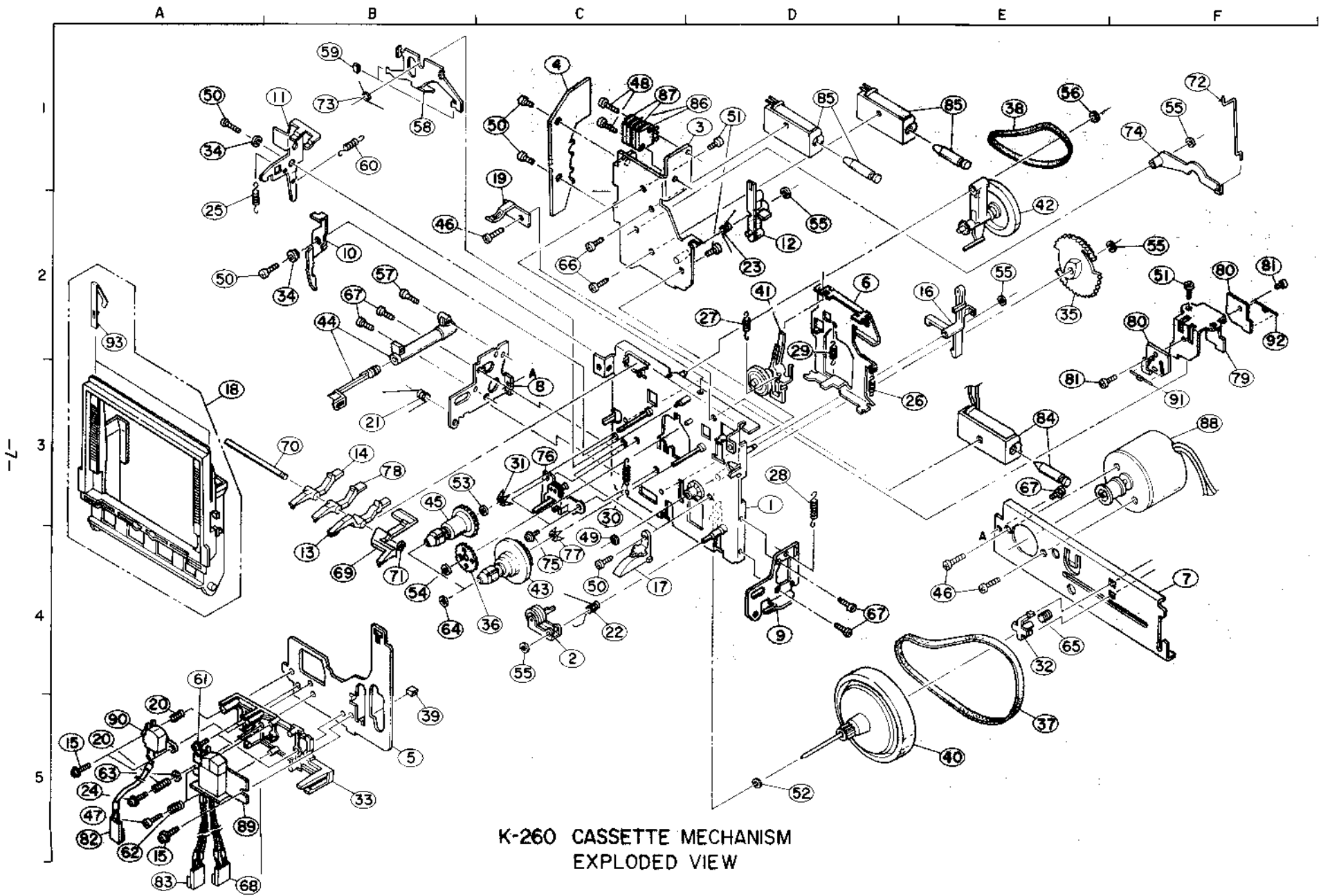

K-260 CASSETTE MECHANISM
EXPLODED VIEW

Exploded View (Mecha)

Exploded View (Mecha) Parts List

Index	Symbol No.	Stock No.	Description	Index	Symbol No.	Stock No.	Description
D3	1	F011-168	Ass'y, Chassis	C1	48	FG143-30	Screw, (M2.6×30)
C4	2	F014-076	Ass'y, Pinch Roller	C4	49	FJ141-12	Washer, Oil Shield
D1	3	F214-018	Bracket, Solenoid Ass'y	C1,C4	50	KG194-12	Screw, (M3×6)
C1	4	FP13D-11	Panel, Connector	D1,F1	51	KG194-46	Screw, (M3×4.5)
B5	5	FC17D-16	Base, Solenoid	D5	52	FJ111-40	Washer, Polyslider
D2	6	FR346-11	Base, Assist	B3	53	FJ111-18	Washer, Polyslider (M2)
F4	7	FR347-12	Bracket, Motor	B4	54	FJ123-14	Polyslider
C3	8	FR349-17	Bracket, Damper	C4,E2	55	FJ123-21	Washer, Lock (M2.6)
D4	9	FR350-15	Bracket, Door	E1	56	FJ123-19	Washer, Lock (M3.5)
B2	10	FR352-11	Lever, Safety	B2	57	UG11D-11	Screw, (M2×12)
B1	11	FC32U-11	Arm, Eject Lock	C1	58	FC15G-14	Lever, Brake
D2	12	FR355-15	Arm, FF Solenoid	B1	59	FF11C-14	Rubber, Brake
B4	13	FD26K-11	Arm, Cassette	B1	60	FK18M-11	Spring, Arm Eject
B3	14	FD26L-12	Arm, Record	A4	61	FG137-13	Screw, F-Lock (M2×5)
A5	15	UG11K-11	Screw, Bind (M2×11.5)	A5	62	FK11F-23	Spring
E2	16	FR359-12	Arm Play Solenoid	A5	63	FJ151-11	Washer, Flat
C4	17	FR360-12	Guid, Cassette	B4	64	FJ111-17	Washer, Polyslider
A3	18	FD29D-11	Frame, Door Ass'y	E4	65	FK11F-16	Spring, Thrust
C1	19	FK551-13	Spring, Cassette	C2	66	FG143-17	Screw, Pan
A5	20	FK572-11	Spring, Azimuth	D4,E3	67	KG189-11	Screw, Pan
B3	21	FK568-11	Spring, Door	A5	68	WH17T-00	Cable, Connector
C4	22	FK569-14	Spring, Pinchroller	B4	69	FD26M-12	Arm (M)
D2	23	FK570-12	Spring, Bkt Solenoid	B3	70	FL25F-11	Shaft (A)
A5	24	UG11K-12	Screw, Bind (M2×18)	B4	71	KG111-19	Ring (E)
A2	25	FK573-11	Spring, Arm Lock	F1	72	FK11Y-14	Brake, Rod
E3	26	FK574-13	Spring, Base Assist	B1	73	FK12A-12	Spring, Brake
D2	27	FK575-11	Spring, Play Idler	F1	74	FD12W-12	Arm, Brake
D3	28	FK576-12	Spring, Play Solenoid Arm	C4	75	FG137-12	Screw, F-Lock
D2	29	FK577-13	Spring, Head Base	C3	76	FR13V-12	Ass'y, Tention Arm
C3	30	FK578-13	Spring, Head Base Hold	C4	77	FK579-14	Spring, Back Tension
C3	31	FK579-15	Spring, Back Tension	B3	78	FD29C-11	Arm (C)
E4	32	FM281-12	Spacer, Flywheel	F3	79	FC15H-11	Bracket, Sensor
B5	33	FD14U-16	Spacer, Head	F2	80	FP11E-12	Panel, Sensor
A1,B2	34	FM296-11	Spacer	F2,F3	81	FG137-11	Screw F-Lock
E2	35	FN153-11	Gear, Play	A5	82	WH17U-00	Cable, Connector
C4	36	FN154-14	Gear, Idler	A5	83	WH17V-00	Cable, Connector
E5	37	FP462-11	Belt, Main	E3	84	F082-046	Solenoid Ass'y
E1	38	FP463-11	Belt, Sub	D1	85	PKA16106	Solenoid (FF, REW)
B5	39	FP464-11	Pad, Cushion	D1	86	FE173-11	Slide Switch
E5	40	FR13L-11	Ass'y, Flywheel	C1	87	FE173-11	Slide Switch
D2	41	FP469-12	Ass'y, Idler	F3	88	F064-093	Ass'y, Motor
E2	42	FP470-11	Ass'y, Clutch	A5	89	88T57524F01	Head, R/P
C4	43	F123-025	Ass'y, Take Up Reel	A5	90	FU163-13	Head, Erase
B2	44	FP472-11	Ass'y, Damper	F3	91	AU11C-00	LED, Sensor
B3	45	F105-019	Ass'y, Supply Reel	F2	92	AZ11H-00	Transistor, Sensor
B2,E4	46	FG114-15	Screw, W/Washer (M2.6×4.5)	A2	93	FC32M-12	SP, Holder
A5	47	UG11M-11	Screw				

Paking Material Parts List

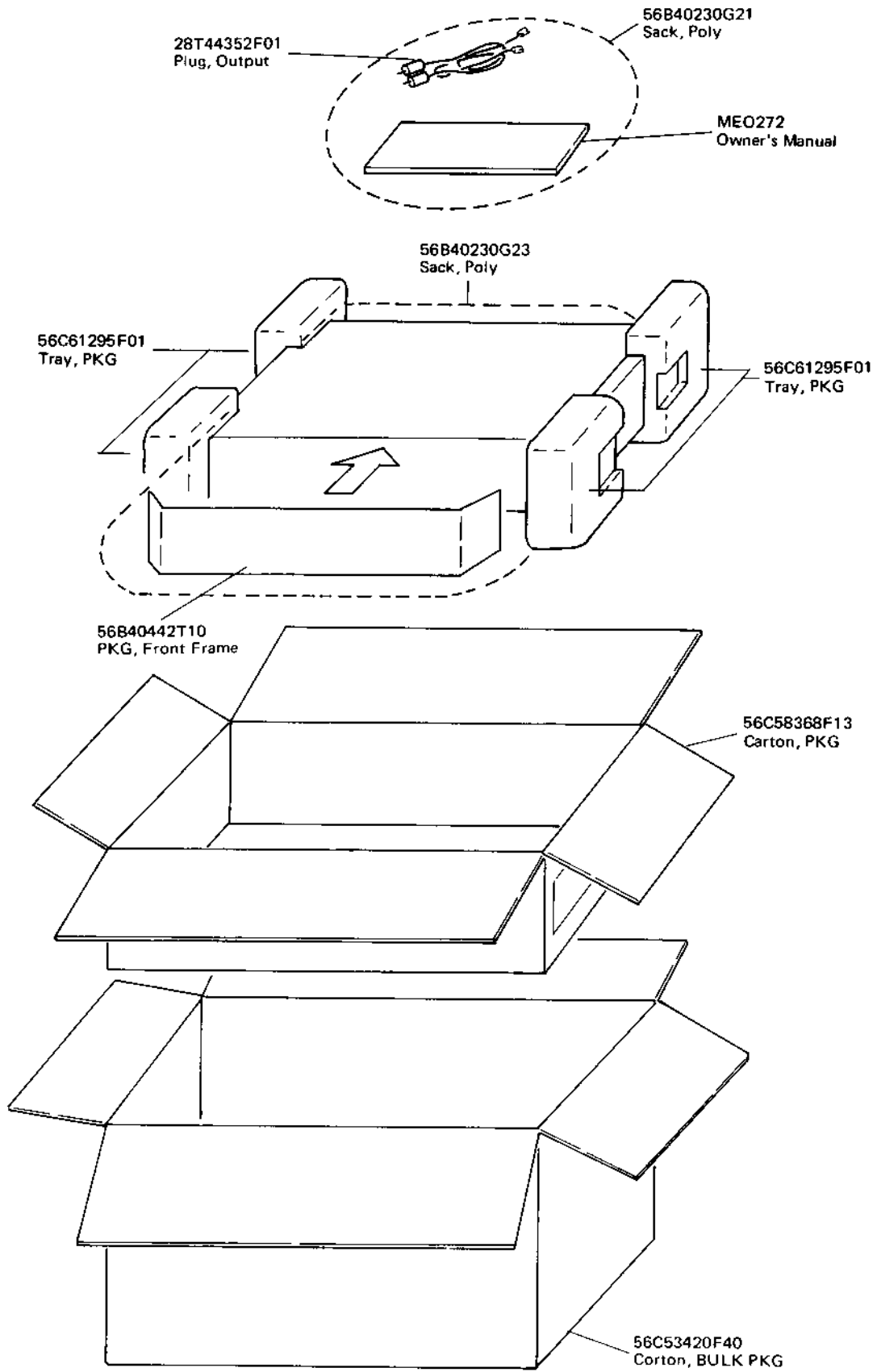

K 260

Master Board

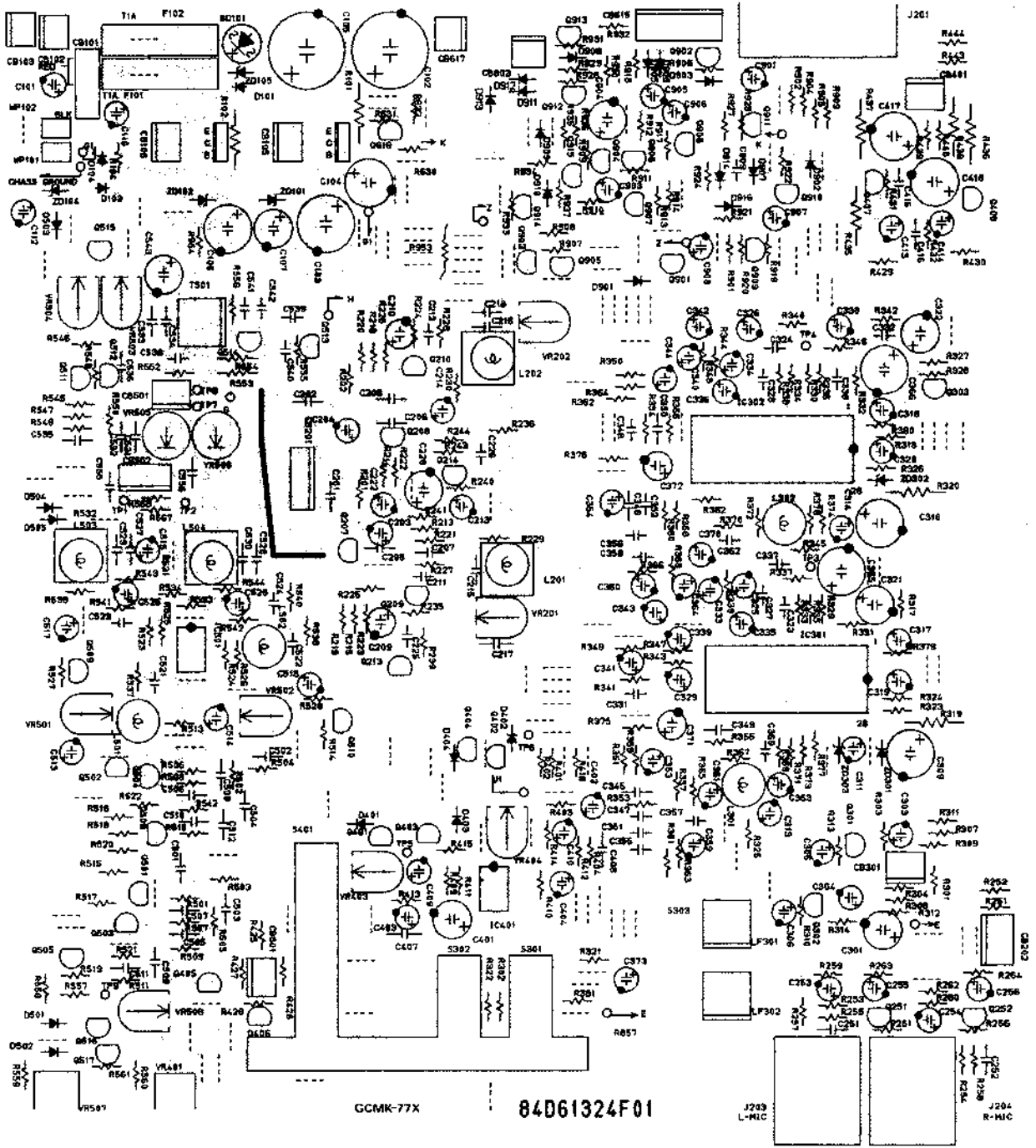

K-260

Master Board Parts List

Symbol No.	Stock No.	Description	Symbol No.	Stock No.	Description
(Switch)					
S301	40T61323F01	Push SUL 3Key	Q406	48T57305F01	2SD1302-S,T
S302	40T61323F01	Push SUL 3Key	Q407	48T43015U01	2SC2120-Y
S401	40T61323F-1	Puch SUL 3Key	Q408	48T43015U01	2SC2120-Y
(Variable,Resistor)					
VR201	18T52946F15	22K	Q501	48S43252F05	2SC1815-Y,GR
VR202	18T52946F15	22K	Q502	48S43252F05	2SC1815-Y,GR
VR401	18T60151F01	5K-A	Q503	48S43252F05	2SC1815-Y,GR
VR403	18T52946F13	10K	Q504	48S43252F05	2SC1815-Y,GR
VR404	18T52946F13	10K	Q505	48S43242F05	2SC1815-Y,GR
VR501	18T52946F17	47K	Q506	48S43252F05	2SC1815-Y,GR
VR502	18T52946F17	47K	Q509	48S57305F01	2SD1202-S,T
VR503	18T52946F19	100K	Q510	43S57305F01	2SD1302-S,T
VR504	18T52946F19	100K	Q511	48S41196U03	2SC1980-T
VR505	18B44064J07	100K 1/2W	Q512	48S41196U03	2SC1980-T
VR506	18B44064J07	100K 1/2W	Q513	48S43525F05	2SC1815-Y,GR
VR507	18T60150F01	1K-B	Q514	48S43525F05	2SC1815-Y,GR
VR508	18T52946F09	2.2K	Q515	48S43515U01	2SC2120-Y
(Filter)					
LF301	91T61321F01	MPX (38K)	Q516	48T61307F01	DTC114
LF302	91T61321F01	MPX (38K)	Q517	48T61307F01	DTC114
(Coil,OSC)					
T501	24T60951F01	O,S,C.	Q616	48S43525F05	2SC1815-Y,GR
(Coil)					
L201	24S42448F99	4700UH	Q901	48T40081T03	2SA733 (P)
L202	24S42448F99	4700UH	Q902	48S43525F05	2SC1815-Y,GR
L301	24T47741F01	36MH	Q903	48T40081T03	2SA733 (P)
L302	24T47741F01	36MH	Q904	48S43525F05	2SC1815-Y,GR
L501	24S41448F97	3300UH	Q905	48S43525F05	2SC1815-Y,GR
L502	24N41448F97	3300uH	Q906	48S43525F05	2SC1815-Y,GR
L503	24T44499P01	27MH	Q907	48T40081T03	2SA733 (P)
L504	24T44499P01	27MH	Q908	48T61307F01	DTC114
(Fuse)					
F101	65T42077U16	Semko 1AT	Q909	48T40081T03	2SA733 (P)
F102	65T42077U16	Semko 1AT	Q910	48S43525F05	2SC1815-Y,GR
Holder,Fuse)					
F101	09T45548F01	Holder	Q911	48S43525F05	2SC1815-Y,GR
F102	09T45548F01	Holder	Q912	48T40081T03	2SA733 (P)
(Jack)					
J201	09T57396F01	4P (JAL)	Q913	48T40081T03	2SA733 (P)
J202	09T57396F01	4P (JAL)	Q914	48T40081T03	2SA733 (P)
J203	09T60076F01	MIC	Q915	48T40081T03	2SA733 (P)
J204	09T60076F01	MIC	(Diode,Bridge)		
(IC)			BD101 48T50629F01 WL-02		
IC301	51T52160F01	HA12038-01	(Diode)		
IC302	51T52160F01	HA12038-01	D101	48T61129F01	GP10-4003-R3
IC401	51S43471U02	UPC4558C	D103	48T61129F01	GP10-4003-R3
IC501	51S43471U02	UPC4558C	D104	48T61129F01	GP10-4003-R3
(Transistor,FET)					
Q213	48F43525F05	2SC1815-Y,GR	D401	48T44813F01	MA165A
Q214	48S43525F05	2SC1815-Y,GR	D402	48T44813F01	MA165TA
Q301	48S43525F05	2SC1815-Y,GR	D403	48T44813F01	MA165TA
Q302	48S43525F05	2SC1815-Y,GR	D404	48T44813F01	MA165TA
Q303	48S43525F05	2SC1815-Y,GR	D501	48T44813F01	MA165TA
Q401	48S47729F02	2SK117 BL	D502	48T44813F01	MA165TA
Q402	48S47729F02	2SK117 BL	D503	48T44813F01	MA165TA
Q403	48S47729F02	2SK117 BL	D504	48T44813F01	MA165TA
Q404	48S47729F02	2SK117 BL	D505	48T44813F01	MA165TA
Q405	48T57305F01	2SD1302-S,TT	D901	48T44813F01	MA165TA
			D902	48T44813F01	MA165TA
			D903	48T44813F01	MA165TA
			D905	48T44813F01	MA165TA
			D906	48T44813F01	MA165TA
			D907	48T44813F01	MA165TA
			D908	48T44813F01	MA165TA
			D909	48T44813F01	MA165TA
			D910	48T44813F01	MA165TA
			D911	48T44813F01	MA165TA

K-260

Symbol No.	Stock No.	Description	Symbol No.	Stock No.	Description
D912	48T44813F01	MA165TA	C314	23S40657F24	22uF 35V E1
D913	48T44813F01	MF165TA	C317	23S40657F28	1uF 50V E1
D914	48T44813F01	MA165TA	C318	23S40657F28	1uF 50V E1
D916	48T44813F01	MA165TA	C319	23S40657F28	1uF 50V E1
(Diode,Zener)			C320	23S40657F28	1uF 50V E1
ZD101	48T40150U80	HZ20-2	C321	23S40657F08	100uF 100V E1
ZD102	48T40150U66	HZ12B-3	C322	23S40657F08	100uF 100V E1
ZD104	48T40150U52	HZ11A1	C323	08S40656F15	0.015uF My
ZD105	48T40150U71	HZ15-2	C324	08S40656F15	0.015uF My
ZD301	48T40150U68	HZ12C-2	C325	23S40657F10	10uF 12V E1
ZD302	48T40150U68	HZ12C-2	C326	23S40657F10	10uF 12V E1
ZD303	48T40150U32	HZ6B-2	C327	08T40656F13	0.01uF My
(Capacitor)			C328	08T40656F13	0.01uF My
C101	23S40657F28	1uF 50V E1	C329	23S40657F16	4.7uF 25V E1
C102	23S41198U67	1000uF 50V E1	C330	23S40657F16	4.7uF 25V E1
C103	23S41198U57	470uF 25V E1	C331	08S40656F16	0.018uF My
C104	23S41198U42	220uF 25V E1	C332	08S40656F16	0.018uF My
C105	23S41198U72	220uF 25V E1	C333	23T42478F21	0.33uF 50V E1
C106	23S41198U56	470uF 16V E1	C334	23T42478F21	0.33uF 50V E1
C107	23S40657F14	100uF 12V E1	C335	23T42478F21	0.33uF 50V E1
C110	23S40657F28	1uF 50V E1	C336	23T42478F21	0.33uF 50V E1
C112	23S40657F16	4.7uF 25V E1	C337	08S40656F15	0.015uF My
C201	08T55260F35	270pF Ce	C338	08S40656F15	0.015uF My
C202	08T55260F35	270pF Ce	C339	23S40657F28	1uF 50V E1
C203	23T42478F09	4.7uF 25V E1	C340	23S40657F28	1uF 50V E1
C204	23T42478F09	4.7uF 25V E1	C341	23S40657F28	1uF 50V E1
C205	08T55260F45	470pF Ce	C342	23S40657F28	1uF 50V E1
C206	08T55260F45	470pF Ce	C343	23S40657F10	10uF 12V E1
C207	08T55260F31	56pF Ce	C344	23S40656F10	10uF 12V E1
C208	08T55260F31	56pF Ce	C345	08T52260F27	39uF Ce
C209	23S40657F08	100uF 100V E1	C346	08T55260F27	39pF Ce
C210	23S40657F08	100uF 100V E1	C347	08S40656F10	5600pF My
C211	08S40656F07	3300pF My	C348	08S40656F10	5600pF My
C212	08S40656F07	3300pF My	C349	08T52260F49	1000pF Ce
C213	23S40657F10	10uF 12V E1	C350	08T55260F49	1000pF Ce
C214	23S40657F10	10uF 12V E1	C351	08S40656F07	3300pF My
C215	08T55260F45	470pF Ce	C352	08S40656F07	3300pF My
C216	08T55260F45	470pF Ce	C353	23S40657F10	10uF 12V E1
C217	08T55260F49	1000pF Ce	C354	23S40657F10	10uF 12V E1
C218	08T55260F49	1000pF Ce	C355	08S40656F08	3900pF My
C222	23S40567F10	10uF 12V E1	C356	08S40656F08	3900pF My
C225	08S40656F14	0.012uF My	C357	08S40656F24	0.082uF My
C226	08S40656F14	0.012uF My	C358	08S40656F24	0.082uF My
C228	23S40657F21	100uF 25V E1	C359	23S40657F16	4.7uF 25V E1
C251	08T55260F49	1000pF Ce	C360	23S40657F16	4.7uF 25V E1
C252	08T55260F49	1000pF Ce	C361	23T42478F19	0.15uF 50V E1
C253	23S40657F16	4.7uF 25V E1	C362	23T42478F19	0.15uF 50V E1
C254	23S40657F16	4.7uF 25V E1	C363	23S40657F27	0.47uF 50V E1
C255	23S40657F10	10uF 12V E1	C364	23S40657F27	0.47uF 50V E1
C256	23S40657F10	10uF 12V E1	C365	23S40657F09	220uF 100V E1
C301	23S40657F20	47uF 25V E1	C366	23S40657F09	220uF 100V E1
C303	23S40657F16	4.7uF 25V E1	C369	08S40657F04	1800pF My
C304	23S40657F16	4.7uF 25V E1	C370	08S40657F04	1800pF My
C305	23S40657F10	10uF 12V EL	C371	23S40657F10	10uF 12V E1
C306	23S40657F10	10uF 12V E1	C372	23S40657F10	10uF 12V E1
C309	23S40657F52	220uF 12V E1	C373	23S40657F10	10uF 12V E1
C310	23S40657F52	220uF 12V E1	C374	23S40657F10	10uF 12V E1
C311	23S40657F12	33uF 12V E1	C401	23S40657F21	100uF 25V E1
C313	23S40657F24	22uF 35V E1	C402	23S40657F13	47uF 12V E1

Symbol No.	Stock No.	Description			Symbol No.	Stock No.	Description		
C403	23T42478F19	0.15uF	50V	E1	C908	23S40657F24	22uF	35V	E1
C404	23T42478F19	0.15uF	50V	E1	C909	08 S 40656 F 2 5	0.1uF		My
C407	08T55260F25	33pF		Ce	(Resistor)				
C408	08T55260F25	33pF		Ce	R101	06T55177F69	1.5K	1W	Rm
C409	23S40657F10	10uF	12V	E1	R102	06T55177F53	330	1W	Rm
C410	23S40657F10	10uF	12V	E1	R104	06S55065F89	10K	1/6W	Rd
C413	23S40657F29	2.2uF	50V	E1	R201	06S55066F10	66K	1/6W	Rd
C414	23S40657F29	2.2uF	50V	E1	R202	06S55066F10	68K	1/6W	Rd
C415	08T55260F33	68pF		Ce	R213	06S55066F14	100K	1/6W	Rd
C416	08T55260F33	68pF		Ce	R214	06S55066F14	100K	1/6W	Rd
C417	23S40657F09	220pF	100V	E1	R215	06S55065F53	330	1/6W	Rd
C418	23S40657F09	220pF	100V	E1	R216	06S55065F53	330	1/6W	Rd
C501	08T55260F49	100pF		Ce	R219	06S55066F22	220K	1/6W	Rd
C502	08T55260F49	100pF		Ce	R220	06S55066F22	220K	1/6W	Rd
C503	08S44503P06	0.0027uF		My	R221	06S55065F97	22K	1/6W	Rd
C504	08S44503P06	0.0027uF		My	R222	06S55065F97	22K	1/6W	Rd
C505	08T55260F45	470pF		Ce	R223	06S55065F69	1.5K	1/6W	Rd
C506	08T55260F45	470pF		Ce	R224	06S55065F69	1.5K	1/6W	Rd
C507	08S44503P02	0.0012uF		My	R225	06S55066F02	33K	1/6W	Rd
C508	08S44503P02	0.0012uF		My	R226	06S55066F02	33K	1/6W	Rd
C509	08T55260F44	390pF		Ce	R227	06S55066F37	910K	1/6W	Rd
C510	08T55260F44	390pF		Ce	R228	06S55066F37	910K	1/6W	Rd
C511	08S44503P02	0.0012uF		My	R229	06S55065F81	4.7K	1/6W	Rd
C512	08S44503P02	0.0012uF		My	R230	06S55065F81	4.7K	1/6W	Rd
C513	23S40657F16	4.7uF	25V	E1	R235	06S55065F83	5.6K	1/6W	Rd
C514	23S40657F16	4.7uF	25V	E1	R236	06S55065F83	5.6K	1/6W	Rd
C515	23S40657F10	10uF	12V	E1	R239	06S55065F97	22K	1/6W	Rd
C517	23S40657F28	1uF	50V	E1	R240	06S55065F97	22K	1/6W	Rd
C518	23S40657F28	1uF	50V	E1	R241	06S55065F99	27K	1/6W	Rd
C521	08S40656F11	6800pF		My	R243	06S55065F67	1.2K	1/6W	Rd
C522	08S40656F11	6800pF		My	R244	06S55065F67	1.2K	1/6W	Rd
C523	08S40656F25	0.1uF		My	R251	06S55065F91	12K	1/6W	Rd
C524	08S40656F25	0.1uF		My	R252	06S55065F91	12K	1/6W	Rd
C525	23S40657F16	4.7uF	25V	E1	R253	06S55065F57	470	1/6W	Rd
C526	23S40657F16	4.7uF	25V	E1	R254	06S55065F57	470	1/6W	Rd
C527	08T55260F43	330pF		Ce	R255	06S55065F89	10K	1/6W	Rd
C528	08T55260F43	330pF		Ce	R256	06S55065F89	10K	1/6W	Rd
C529	08T55260F35	82pF		Ce	R257	06S55066F30	470K	1/6W	Rd
C530	08T55260F35	82pF		Ce	R258	06S55066F30	470K	1/6W	Rd
C531	08T55260F49	1000pF		Ce	R259	06S55066F38	1M	1/6W	Rd
C532	08T55260F49	1000pF		Ce	R260	06S55066F38	1M	1/6W	Rd
C533	08T55260F43	330pF		Ce	R261	06S55065F89	10K	1/6W	Rd
C534	08T55260F43	330pF		Ce	R262	06S55065F89	10K	1/6W	Rd
C535	08T55260F49	1000pF		Ce	R263	06S55066F14	100K	1/6W	Rd
C536	08T55260F49	1000pF		Ce	R264	06S55066F14	100K	1/6W	Rd
C538	08T52448F35	8200pF		Pp	R301	06S55065F81	4.7K	1/6W	Rd
C539	08S40656F11	6800pF		My	R302	06S55066F06	47K	1/6W	Rd
C540	08S40656F07	3300pF		My	R303	06S55065F41	100	1/6W	Rd
C541	08S40657F07	3300pF		My	R304	06S55065F41	100	1/6W	Rd
C542	08S40656F13	0.01uF		My	R307	06S55066F24	270K	1/6W	Rd
C543	23S40657F20	47uF	2.5V	E1	R308	06S55066F24	270K	1/6W	Rd
C555	08T55260F43	330pF		Ce	R309	06S55066F06	47K	1/6W	Rd
C556	08T55260F43	330pF		Ce	R310	06S55066F06	47K	1/6W	Rd
C901	23S40657F28	1uF	50V	E1	R311	06S55065F74	2.4K	1/6W	Rd
C903	23S40657F16	4.7uF	25V	E1	R312	06S55065F74	2.4K	1/6W	Rd
C904	23S40657F21	100uF	25V	E1	R313	06S55065F71	1.8K	1/6W	Rd
C905	23S40657F16	4.7uF	25V	E1	R314	06S55065F71	1.8K	1/6W	Rd
C906	23S40657F10	10uF	12V	E1	R319	06T55179F47	180	2W	Rm
C907	23S40657F16	4.7uF	25V	E1	R320	06T55179F47	180	2W	Rm

K-260

Symbol No.	Stock No.	Description			Symbol No.	Stock No.	Description		
R321	06S55065F81	4.7K	1/6W	Rd	R380	06S55065F83	5.6K	1/6W	Rd
R322	06S55065F83	5.6K	1/6W	Rd	R381	06S55065F65	1K	1/6W	Rd
R323	06S55065F73	2.2K	1/6W	Rd	R401	06S55065F67	1.2K	1/6W	Rd
R324	06S55065F87	8.2	1/6W	Rd	R402	06S55065F67	1.2K	1/6W	Rd
R325	06S55066F02	33K	1/6W	Rd	R403	06S55065F89	10K	1/6W	Rd
R326	06S55066F02	33K	1/6W	Rd	R404	06S55065F89	10K	1/6W	Rd
R327	06S55065F97	22K	1/6W	Rd	R404	06S55065F89	10K	1/6W	Rd
R328	06S55065F97	22K	1/6W	Rd	R409	06S55065F73	2.2K	1/6W	Rd
R329	06S55066F08	56K	1/6W	Rd	R410	06S55065F73	2.2K	1/6W	Rd
R330	06S55066F08	56K	1/6W	Rd	R411	06S55066F30	470K	1/6W	Rd
R331	06S55066F08	56K	1/6W	Rd	R412	06S55066F30	470K	1/6W	Rd
R332	06S55066F08	56K	1/6W	Rd	R413	06S55065F99	27K	1/6W	Rd
R333	06S55065F82	5.1K	1/6W	Rd	R414	06S55065F99	27K	1/6W	Rd
R334	06S55065F82	5.1K	1/6W	Rd	R415	06S55066F14	100K	1/6W	Rd
R335	06S55065F93	15K	1/6W	Rd	R416	06S55066F14	100K	1/6W	Rd
R336	06S55065F93	15K	1/6W	Rd	R425	06S55065F53	330	1/6W	Rd
R337	06S55065F47	180	1/6W	Rd	R426	06S55065F53	330	1/6W	Rd
R338	06S55065F47	180	1/6W	Rd	R427	06S55065F81	4.7K	1/6W	Rd
R339	06S55066F06	47K	1/6W	Rd	R428	06S55065F81	4.7K	1/6W	Rd
R340	06S55066F06	47K	1/6W	Rd	R429	06S55065F55	390	1/6W	Rd
R341	06S55065F34	6.2K	1/6W	Rd	R430	06S55065F55	390	1/6W	Rd
R342	06S55065F84	6.2K	1/6W	Rd	R431	06S55066F12	32K	1/6W	Rd
R343	06S55066F12	82K	1/6W	Rd	R432	06S55066F12	32K	1/6W	Rd
R344	06S55066F12	82K	1/6W	Rd	R435	06T55177F53	330	1W	Rm
R345	06S55065F41	100	1/6W	Rd	R436	06T55177F53	330	1W	Rm
R346	06S55065F41	100	1/6W	Rd	R437	06T55175F29	33	1/2W	Rm
R347	06S55066F38	1M	1/6W	Rd	R438	06T55175F29	33	1/2W	Rm
R348	06S55066F38	1M	1/6W	Rd	R439	06S55065F89	10K	1/6W	Rd
R349	06S55065F82	5.1K	1/6W	Rd	R440	06S55065F89	10K	1/6W	Rd
R350	06S55065F82	5.1K	1/6W	Rd	R443	06S55065F65	1K	1/6W	Rd
R351	06S55065F89	10K	1/6W	Rd	R444	06S55065F65	1K	1/6W	Rd
R352	06S55065F89	10K	1/6W	Rd	R501	06S55066F02	33K	1/6W	Rd
R353	06S55066F10	68K	1/6W	Rd	R502	06S55066F02	33K	1/6W	Rd
R354	06S55066F10	68K	1/6W	Rd	R503	06S55066F01	30K	1/6W	Rd
R355	06S55066F81	4.7K	1/6W	Rd	R504	06S55066F01	30K	1/6W	Rd
R356	06S55066F81	4.7K	1/6W	Rd	R505	06S55066F12	82K	1/6W	Rd
R357	06S55065F50	240	1/6W	Rd	R506	06S55066F12	82K	1/6W	Rd
R358	06S55065F50	240	1/6W	Rd	R507	06S55066F04	39K	1/6W	Rd
R359	06S55066F08	56K	1/6W	Rd	R508	06S55066F04	39K	1/6W	Rd
R360	06S55066F08	56K	1/6W	Rd	R509	06S55066F07	51K	1/6W	Rd
R361	06S55065F49	220	1/6W	Rd	R510	06S55066F07	51K	1/6W	Rd
R362	06S55065F49	220	1/6W	Rd	R511	06S55065F99	27K	1/6W	Rd
R363	06S55065F87	8.2K	1/6W	Rd	R512	06S55065F99	27K	1/6W	Rd
R364	06S55065F87	8.2K	1/6W	Rd	R513	06S55065F89	10K	1/6W	Rd
R365	06S55065F84	6.2K	1/6W	Rd	R514	06S55065F89	10K	1/6W	Rd
R366	06S55065F34	6.2K	1/6W	Rd	R515	06S55066F10	68K	1/6W	Rd
R367	06S55066F12	82K	1/6W	Rd	R516	06S55066F10	68K	1/6W	Rd
R368	06S55066F12	82K	1/6W	Rd	R517	06S55066F10	68K	1/6W	Rd
R369	06S55065F65	1K	1/6W	Rd	R518	06S55066F10	6 8 K	1/6W	Rd
R370	06S55065F65	1K	1/6W	Rd	R519	06S55066F10	68K	1/6W	Rd
R371	06S55065F77	3.3K	1/6W	Rd	R520	06S55066F10	68K	1/6W	Rd
R372	06S55065F77	3.3K	1/6W	Rd	R521	06S55066F06	47K	1/6W	Rd
R373	06S55065F87	8.2K	1/6W	Rd	R522	06S55066F06	47K	1/6W	Rd
R374	06S55065F87	8.2K	1/6W	Rd	R523	06S55066F08	56K	1/6W	Rd
R375	06S55065F82	5.1K	1/6W	Rd	R524	06S55066F08	56K	1/6W	Rd
R376	06S55065F82	5.1K	1/6W	Rd	R525	06S55065F77	3.3K	1/6W	Rd
R377	06S55065F87	8.2K	1/6W	Rd	R526	06S55065F77	3.3K	1/6W	Rd
R378	06S55065F87	8.2K	1/6W	Rd	R527	06S55065F99	27K	1/6W	Rd
R379	06S55065F83	5.6K	1/6W	Rd	R528	06S55065F99	27K	1/6W	Rd
					R533	06S55065F89	10K	1/6W	Rd

Symbol No.	Stock No.	Description	Symbol No.	Stock No.	Description
R534	06S55065F89	10K 1/6W Rd	R904	06S55065D97	22K 1/6W Rd
R537	06S55065F41	100 1/6W Rd	R905	06S55065D97	22K 1/6W Rd
R538	06S55065F41	100 1/6W Rd	R906	06S55065F89	10K 1/6W Rd
R539	06S55066F02	33K 1/6W Rd	R907	06S55065F89	10K 1/6W Rd
R540	06S55066F02	33K 1/6W Rd	R908	06S55065F89	10K 1/6W Rd
R541	06S55066F20	180K 1/6W Rd	R909	06S55065F81	4.7K 1/6W Rd
R542	06S55066F20	180K 1/6W Rd	R910	06S55065F97	22K 1/6W Rd
R543	06S55065F81	4.7K 1/6W Rd	R911	06S55065F97	22K 1/6W Rd
R544	06S55065F81	4.7K 1/6W Rd	R912	06S55066F06	47K 1/6W Rd
R545	06S55066F38	1M 1/6W Rd	R913	06S55065F89	10K 1/6W Rd
R546	06S55066F38	1M 1/6W Rd	R914	06S55065F89	10K 1/6W Rd
R547	06S55065F89	10K 1/6W Rd	R917	06S55065F87	8.2K 1/6W Rd
R548	06S55065F89	10K 1/6W Rd	R918	06S55065F73	2.2K 1/6W Rd
R549	06S55065F89	10K 1/6W Rd	R919	06S55065F97	22K 1/6W Rd
R550	06S55065F89	10K 1/6W Rd	R920	06S55065F02	33K 1/6W Rd
R552	06S55175F01	2.2 1/6W Rd	R921	06S55065F97	22K 1/6W Rd
R553	06T55175F13	6.8 1/2W Rd	R922	06S55065F97	22K 1/6W Rd
R554	06T55175F13	6.8 1/2W Rd	R924	06S55065F97	22K 1/6W Rd
R555	06S55065F97	22K 1/6W Rd	R925	06S55065F97	15K 1/6W Rd
R556	06S55065F97	22K 1/6W Rd	R927	06S55066F02	33K 1/6W Rd
R557	06S55065F49	220 1/6W Rd	R928	06S55065F89	10K 1/6W Rd
R558	06S55065F49	220 1/6W Rd	R929	06S55065F89	10K 1/6W Rd
R559	06S55065F77	3.3K 1/6W Rd	R930	06S55065F89	10K 1/6W Rd
R560	06S55065F89	10K 1/6W Rd	R931	06S55065F89	10K 1/6W Rd
R561	06S55065F75	2.7K 1/6W Rd	R932	06S55065F89	10K 1/6W Rd
R567	06S55065F17	10 1/6W Rd	R933	06S55065F89	10K 1/6W Rd
R568	06S55065F17	10 1/6W Rd	R934	06S55065F89	10K 1/6W Rd
R630	06S55065F97	22K 1/6W Rd	R935	06S55065F89	10K 1/6W Rd
R631	06S55065F75	2.7K 1/6W Rd	R936	06S55065F89	10K 1/6W Rd
R632	06S55065D89	10K 1/6W Rd	R937	05S55065F89	10K 1/6W Rd
R901	06S55065F89	10K 1/6W Rd	R953	06S41801P64	470K 1/4W Rd
R902	06S55065F89	10K 1/6W Rd	R954	06S55066F30	470K 1/6W Rd
R903	06S55065D97	22K 1/6W Rd			

Key Board Switch PCB Parts List

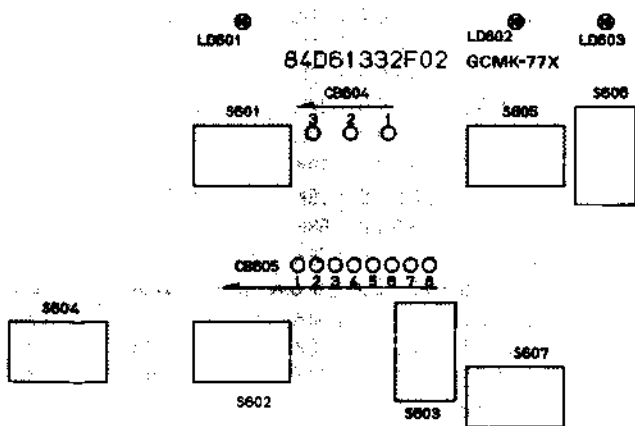

Symbol No.	Stock No.	Description
(Switch)		
S601	40T44505F01	SW, KHG
S602	40T44505F01	SW, KHG
S603	40T44505F01	SW, KHG
S604	40T44505F01	SW, KHG
S605	40T44505F01	SW, KHG
S606	40T44505F01	SW, KHG
S607	40T44505F01	SW, KHG

Memory & Reset PCB Parts List

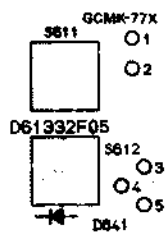

Symbol No.	Stock No.	Description
(Switch)		
	40T57207F01	SW, SPH12-A
	40T57208F01	SW, SPH12-A

Rotary Switch PCB Parts List

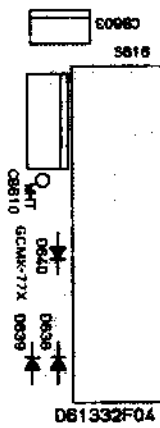

Symbol No.	Stock No.	Description
(Switch)		
S616	40T57206F01	Rotary, SRZ-S 6-4
(Diode)		
D638	48T44813F01	MA-165TA
D640	48T44813F01	MA-165TA

FL Meter PCB

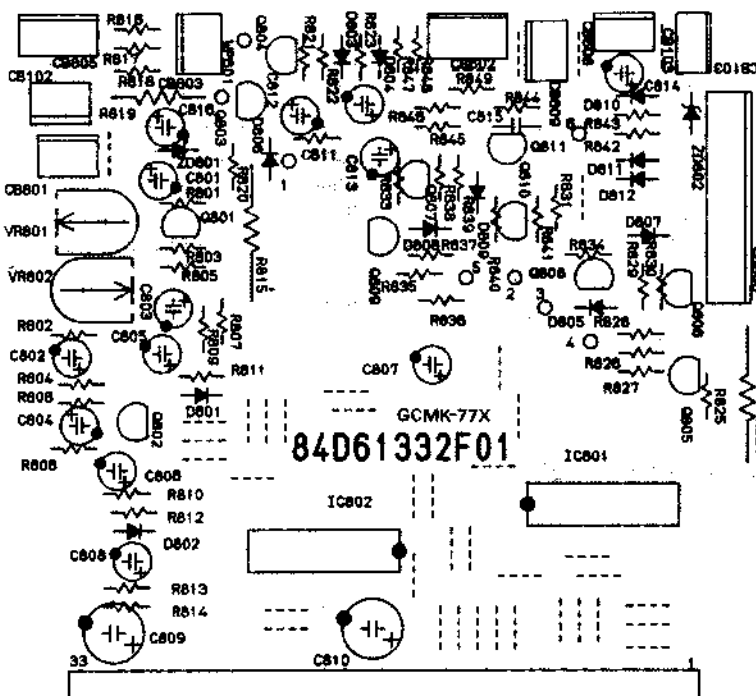

FL Meter PCB Parts List

Symbol No.	Stock No.	Description			
(IC)					
IC801	51T42626F01	HA12019			
IC802	51T42626F01	HA12019			
(Transistor)					
Q801	48S43525F05	2SC1815-Y, GR			
Q802	48S43525F05	2SC1815-Y, GR			
Q805	48T40031T03	2SA733(P)			
Q806	48T40031T03	2SA733(P)			
Q807	48S43525F05	2SC1815-Y, GR			
Q808	48S43525F05	2SC1815-Y, GR			
Q809	48S43525F05	2SC1815-Y, GR			
Q810	48S43525F05	2SC1815-Y, GR			
Q811	48S43525F05	2SC1815-Y, GR			
(Variable, Resistor)					
VR801	18T52946F17	4.7K			
VR802	18T52946F17	4.7K			
(FL Meter)					
E801	65T52950F01	Meter FIP 12DW7YS			
(Diode)					
D801	48T43982F01	GE OA05			
D802	48T43982F01	GE OA95			
D805	48T44813F01	MA165TAX			
D806	48T44813F01	MA165TAX			
D807	48T44813F01	MA165TAX			
D808	48T44813F01	MA165TAX			
D809	48T44813F01	MA165TAX			
D810	48T44813F01	MA165TAX			
D811	48T44813F01	MA165TAX			
D812	48T44813F01	MA165TAX			
(Diode, Zener)					
ZD801	48T40150U32	HZ6B-2			
ZD802	48T40150U05	HZ3B2			
(Capacitor)					
C801	23S40657F10	16uF	16V	E1	
C802	23S40546F10	10uF	16V	E1	
C803	23S40657F17	10uF	25V	E1	
C804	23S40657F17	10uF	25V	E1	
C805	23S40657F17	10uF	25V	E1	
C806	23S40657F17	10uF	25V	E1	
C807	23T42478F21	0.33uF	50V	E1	
C808	23T42478F21	0.33uF	50V	E1	
C809	23S40657F21	100uF	25V	E1	
C810	23S40546F21	100uF	25V	EL	
C812	23S40657F29	2.2uF	50V	E1	
C813	23S40657F16	4.7uF	25V	E1	
C814	23S40546F16	4.7uF	25V	E1	

Symbol No.	Stock No.	Description			
(Resistor)					
R801	06S55065F89	10K	1/6W	Rd	
R802	06S55065F89	16K	1/6W	Rd	
R803	06S55066F29	430K	1/6W	Rd	
R804	06S55066F29	430K	1/6W	Rd	
R805	06S55065F71	1.8K	1/6W	Rd	
R806	06S55065F71	1.8K	1/6W	Rd	
R807	06S55066F18	150K	1/6W	Rd	
R808	07S55066F18	150K	1/6W	Rd	
R809	06S40151T50	3.3M	1/4W	Rd	
R810	06S40151T50	3.3M	1/4W	Rd	
R811	06S55065F85	6.8K	1/6W	Rd	
R812	06S55065F85	6.8K	1/6W	Rd	
R813	06S55065F49	220	1/6W	Rd	
R814	06S55065F49	220	1/6W	Rd	
R815	06T55179F47	18	2W	Rm	
R816	06S55065F41	100	1/6W	Rd	
R817	06S55065F41	100	1/6W	Rd	
R818	06S55065F41	100	1/6W	Rd	
R819	06T55175F51	27	1/2W	Rm	
R824	06T55179F51	27	2W	Rm	
R825	06S55066F14	100K	1/6W	Rd	
R826	06S44065F89	10K	1/6W	Rd	
R827	06S55066F07	51K	1/6W	Rd	
R828	06S55066F07	51K	1/6W	Rd	
R829	06S55065F89	10K	1/6W	Rd	
R830	06S55066F14	100K	1/6W	Rd	
R831	06S55065F89	10K	1/6W	Rd	
R832	06S55065F97	22K	1/6W	Rd	
R833	06S55066F14	100K	1/6W	Rd	
R834	06S55065F89	10K	1/6W	Rd	
R835	06S55065F89	10K	1/6W	Rd	
R836	06S55065F89	10K	1/6W	Rd	
R837	06S55065F97	22K	1/6W	Rd	
R838	06S55065F97	22K	1/6W	Rd	
R839	06S55065F41	100	1/6W	Rd	
R840	06S55066F14	100K	1/6W	Rd	
R841	06S55065F89	10K	1/6W	Rd	
R842	06S55065F73	2.2K	1/6W	Rd	
R843	06S55066F14	100K	1/6W	Rd	
R844	06S55065F89	10K	1/6W	Rd	
R846	06S55065F79	3.9K	1/6W	Rd	
R847	06S55066F02	33K	1/6W	Rd	
R848	06S55065F59	560	1/6W	Rd	
R849	06S55065F69	1.5K	1/6W	Rd	

Indicator PCB Parts List



Symbol No.	Stock No.	Description
(Lamp)		
PL617	65B43447J03	Lamp, Pilot
PL618	65B43447J03	Lamp, Pilot
PL619	65B43447J03	Lamp, Pilot

Control PCB

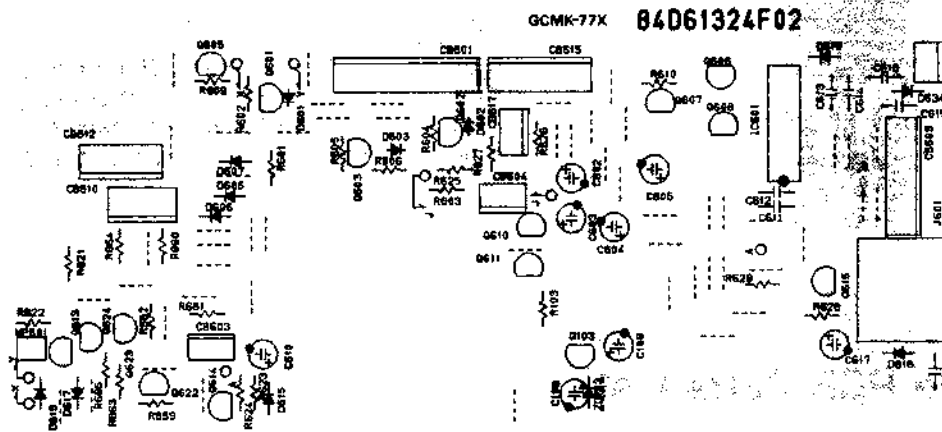

Control PCB Parts List

Symbol No.	Stock No.	Description	Symbol No.	Stock No.	Description
(IC)					
IC601	51S47110F01	BA843	C602	23S40657F10	10uF 16V E1
(Transistor)					
Q103	48T43015U01	2SC2120-Y	C603	23S40657F09	220uF 16V E1
Q601	48T43015U01	2SC2120-Y	C604	23S40657F09	220uF 16V E1
Q602	48T43015U01	2SC2120-Y	C605	23S40657F09	220uF 16V E1
Q603	48T43015U01	2SC2120-Y	C610	23S40657F08	100uF 10V E1
Q605	48S43525F05	2SC1815-Y, GR	C611	08T55260F61	0.01uF Ce
Q606	48S43525F05	2SC1815-Y, GR	C612	08T55260F61	0.01uF Ce
Q607	48S43525F05	2SC1815-Y, GR	C613	08T55260F61	0.01uF Ce
Q608	48S43525F05	2SC1815-Y, GR	C614	08T55260F61	0.01uF Ce
Q610	48S43525F05	2SC1815-Y, GR	C615	08T55260F61	0.01uF Ce
Q611	48S43525F05	2SC1815-Y, GR	C616	08T55260F61	0.01uF Ce
Q613	48S43525F05	2SC1815-Y, GR	C617	23S40657F07	47uF 10V E1
Q614	48S43525F05	2SC1815-Y, GR	C627	08T55260F61	0.01uF Ce
Q615	48S43525F05	2SC1815-Y, GR	(Resistor)		
Q622	48S43525F05	2SC1815-Y, GR	R103	06S55065F63	820 1/6W Rd
Q623	48S43525F05	2SC1815-Y, GR	R601	06S55065F73	2.2K 1/6W Rd
Q624	48S43525F05	2SC1815-Y, GR	R602	06S55065F59	560 1/6W Rd
(Diode)					
D601	48T61129F01	GP10-4003-R5	R603	06S55065F59	560 1/6W Rd
D602	48T61129F01	GP10-4003-R5	R604	06S55065F53	330 1/6W Rd
D603	48T61129F01	GP10-4003-R5	R605	06S55065F53	330 1/6W Rd
D605	48T44813F01	MA165TA	R606	06S55065F59	560 1/6W Rd
D606	48T44813F01	MA165TA	R609	06S55066F06	47K 1/6W Rd
D607	48T44813F01	MA165TA	R610	06S55066F06	47K 1/6W Rd
D615	48T44813F01	MA165TA	R621	06S55065F89	10K 1/6W Rd
D616	48T44813F01	MA165TA	R622	06S55065F89	10K 1/6W Rd
D617	48T43982F01	GE OA95	R623	06S55066F04	39K 1/6W Rd
D618	48T44813F01	MA165A	R624	06S55066F02	33K 1/6W Rd
D619	48T44813F01	MA165A	R625	06S55065F41	100 1/6W Rd
D634	48T43982F01	GE OA95	R626	06S55065F41	100 1/6W Rd
(Diode, Zener)					
ZD103	48T40150U32	HZ6B-2	R627	06S55065F77	3.3K 1/6W Rd
(Jack)					
J601	09T50261F01	Cont	R628	06S55066F06	47K 1/6W Rd
(Capacitor)					
C108	23S40657F10	10uF 16V E1	R629	06S55066F02	33K 1/6W Rd
C109	23S40657F10	10uF 16V E1	R659	06S55065F93	15K 1/6W Rd
			R660	06S55066F06	47K 1/6W Rd
			R611	06S55065F97	22K 1/6W Rd
			R662	06S55065F89	10K 1/6W Rd
			R663	06S55066F14	100K 1/6W Rd
			R664	06S55066F06	47K 1/6W Rd
			R665	06S55065F93	15K 1/6W Rd

Schematic Diagram(A)

LUX K-260 AMP CIRCUIT

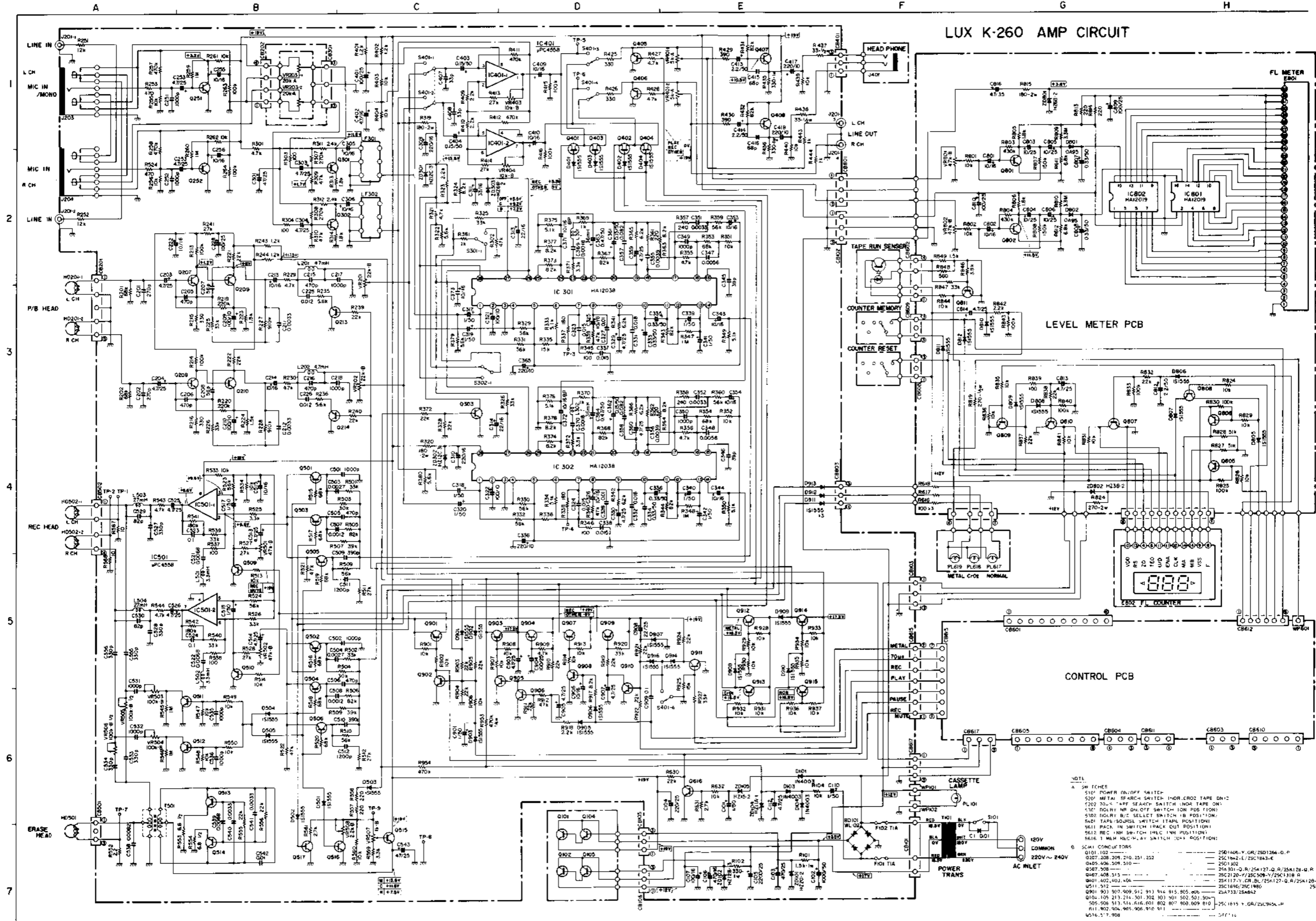

- NOTES
- A SWITCHES
- S101 POWER ON/OFF SWITCH
 - S201 METAL SEARCH SWITCH (FOR CROZ TAPE ONLY)
 - S301 70L-4 "AFF" SEARCH SWITCH (FOR TAPE ONLY)
 - S401 DOLBY NR ON/OFF SWITCH (ON POSITION)
 - S501 DOLBY B/E SELECT SWITCH (B POSITION)
 - S601 TAPE SOURCE SWITCH (TAPES POSITION)
 - S701 PACK IN SWITCH (TRACK OUT POSITION)
 - S801 REC INH SWITCH (INH POSITION)
 - S901 1 W/M ABC/PLAY SWITCH (OFF POSITION)
- B SCHEMATIC CONNECTIONS
- | | |
|--|--|
| Q101, 102 | 2SD1406-Y, GR/2SD1266-G, P |
| Q207, 208, 209, 210, 251, 252 | 2SC1842-E/2SC1843-E |
| Q301, 302 | 2SD1302 |
| Q307, 308 | 2SC301-Q, R/2SC127-Q, R/2SC128-Q, R |
| Q407, 408, 515 | 2SC2120-F/2SC509-Y/2SC1318-R |
| Q501, 502, 601, 602 | 2SA117-Y, CR, BL/2SA127-Q, R/2SA128-Q, H/2SC1692/2SC1480 |
| Q901, 903, 907, 909, 912, 913, 916, 915, 905, 906 | 2SA733/2SA642 |
| Q101, 105, 213, 214, 301, 302, 303, 304, 502, 503, 504 | 2SC1843 |
| 505, 506, 513, 514, 616, 601, 802, 807, 803, 609, 810 | 2SC1615-Y, GR/2SC1266-G, P |
| R11, 902, 904, 905, 906, 910, 911 | 5116-1, 7, 908 |

Schematic Diagram(B)

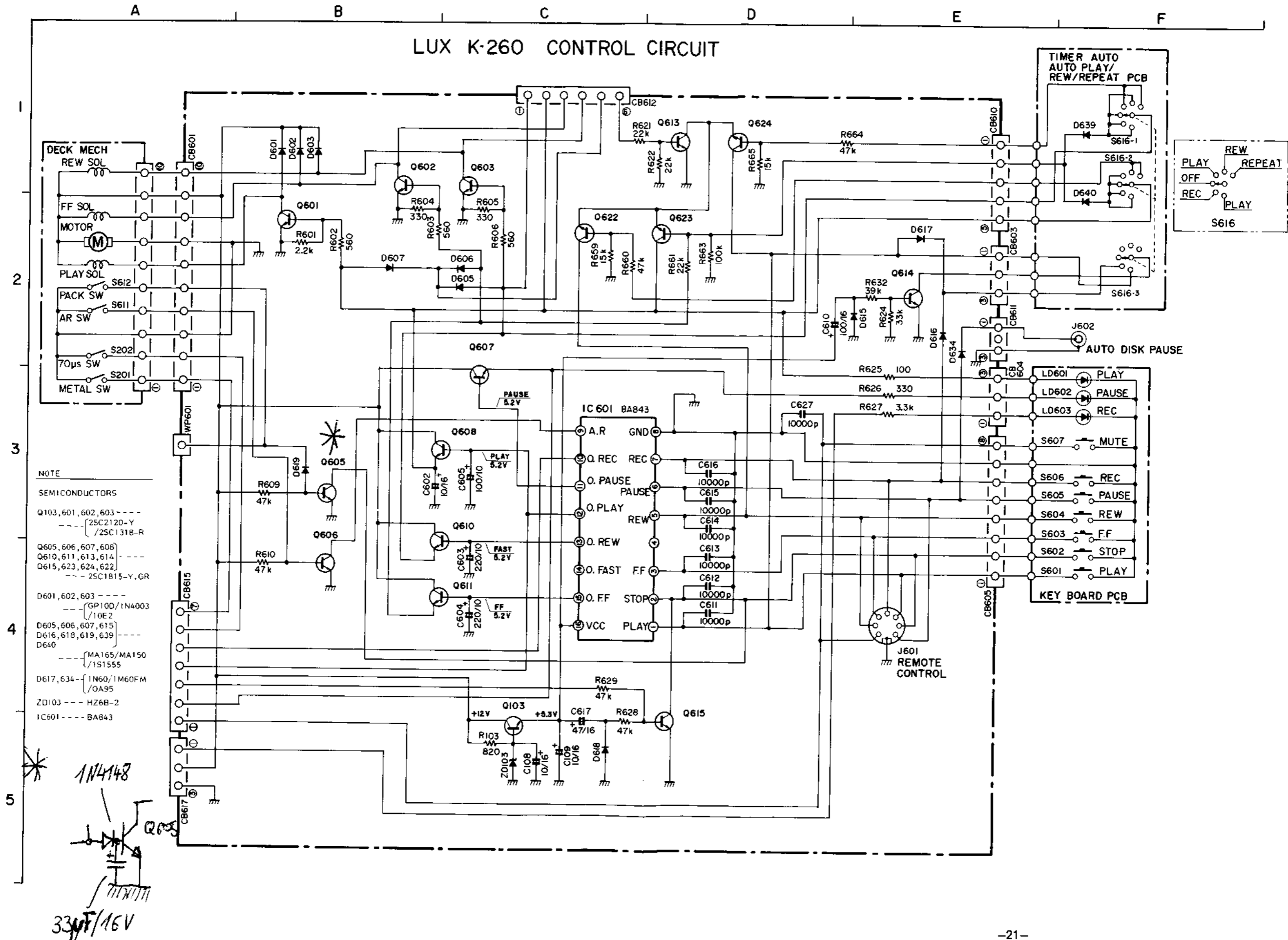

IC Handling Guide

HA12019. (IC801, IC802 Stock No. 51T42626F01)
Fluorescent Tube Driver for Bar Graph Display

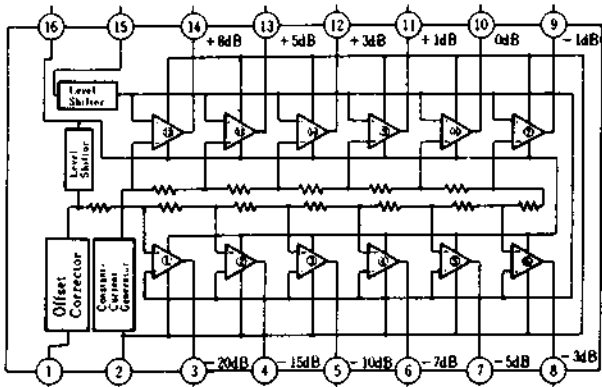

HA12038. (IC301, 302 Stock No. 51T52160F01)
Dolby-Band-C Type Noise Reduction System

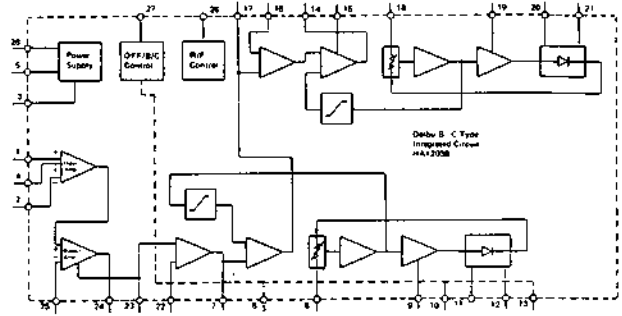

BA843 (IC601 Stock No. 51S47110F01)
Key Control

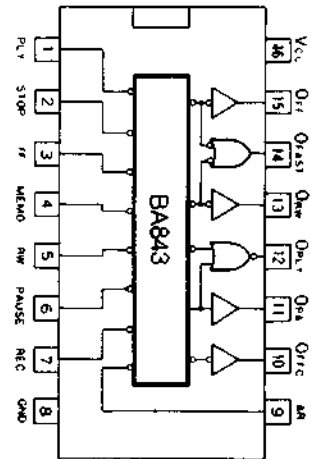
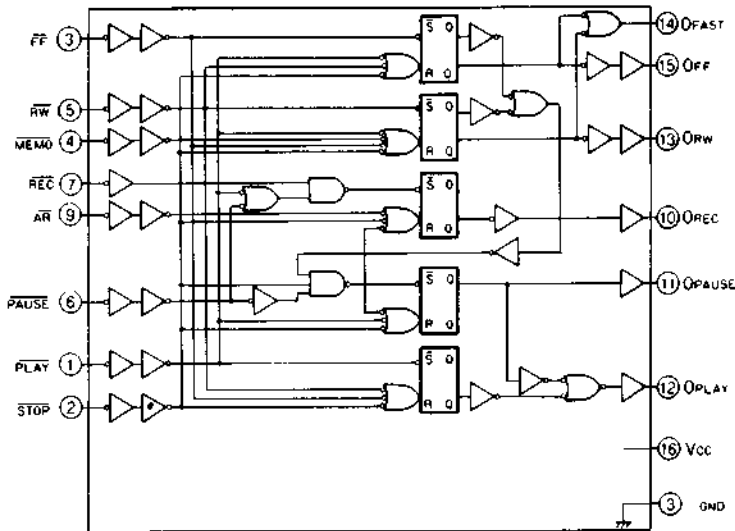

μ PC4558C (IC401, 501 Stock No. 51S43471U02)

Equivalent Circuit

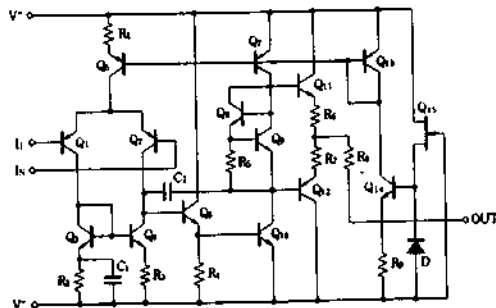

Connection Diagram (Top View)

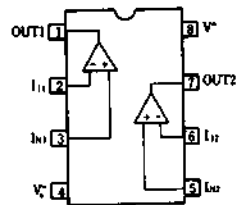

Specifications

Heads:	3
Record head	Hexalam
Playback head	Ferrite
Erase head	Double Gap Sendust Ferrite
Wow & Flutter: (WRMS)	0.035%
Signal-to-Noise Ratio: (CCIR weighted)	
Metal-Tape, without NR	59dB
Metal-Tape, with Dolby-B-NR	68dB
Metal-Tape, with Dolby-C-NR	72dB
CrO ₂ -Tape, without NR	59dB
CrO ₂ -tape, with Dolby-B-NR	68dB
CrO ₂ -Tape, with Dolby-C-NR	72dB
Nor-Tape, without NR	57dB
Nor-Tape, with Dolby-B-NR	67dB
Nor-Tape, with Dolby-C-NR	71dB
Frequency Response:	
Metal Tape:	20Hz~21.000Hz (20Hz~19.000Hz±3dB)
CrO ₂ Tape:	20Hz~20.000Hz (20Hz~18.000Hz±3dB)
Nor. Tape:	20Hz~19.000Hz (20Hz~17.000Hz±3dB)
The 3rd Harmonic Distor. ion: (Normal tape, 1kHz, 0dB)	0.6%
Input Sensitivity:	line in: 80mV microphone: 300 μ V
Output Level:	line out: 500mV headphone: 1mW (8 ohms load)
Power Consumption:	26W
Dimensions:	453(W)×270(D)× 111(H)mm (17.8"×10.6"×4.3")
Weight:	Net: 5.0kgs(11.0 lbs) Gross: 6.0kgs(13.2 lbs)

Specifications and appearance design subject to change without notice.

• NOISE REDUCTION CIRCUIT MADE UNDER LICENCE FROM DOLBY LABORATORIES. THE WORD "DOLBY" AND THE DOUBLE-D SYMBOL ARE THE TRADE MARKS OF DOLBY LABORATORIES.

• dbx is the trade marks of dbx Incorporated.



LUX CORPORATION, JAPAN

1-1, 1-CHOME, SHINSENRI-NISHIMACHI, TOYONAKA-SHI, OSAKA 565
PHONE 06-834-0004 CABLE LUXMAN TOYONAKA TELEX 5287106 LUXELE J

K-NK. 8312. 010A Printed in Japan