

SERVICE MANUAL

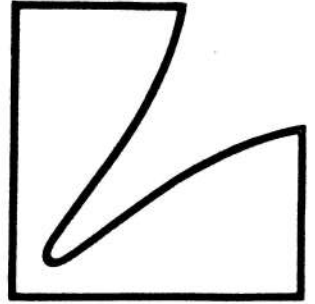

LUXMAN STEREO CASSETTE DECK

K-230

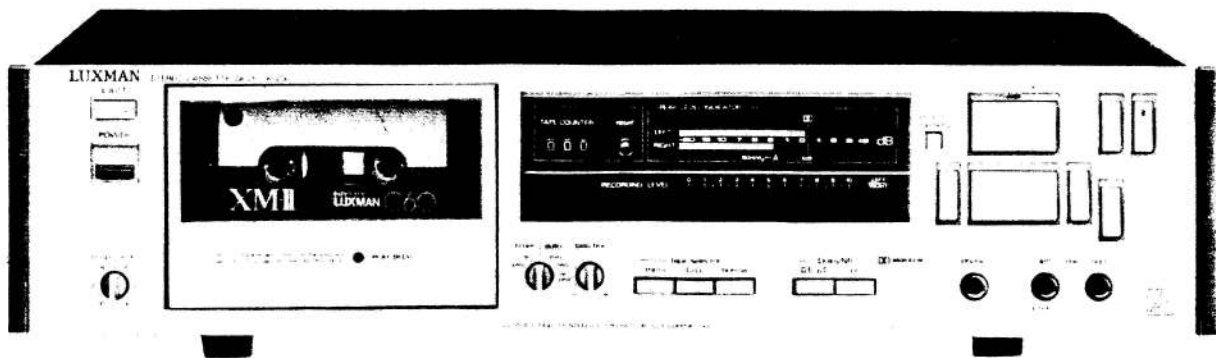

K-230

Level Diagram

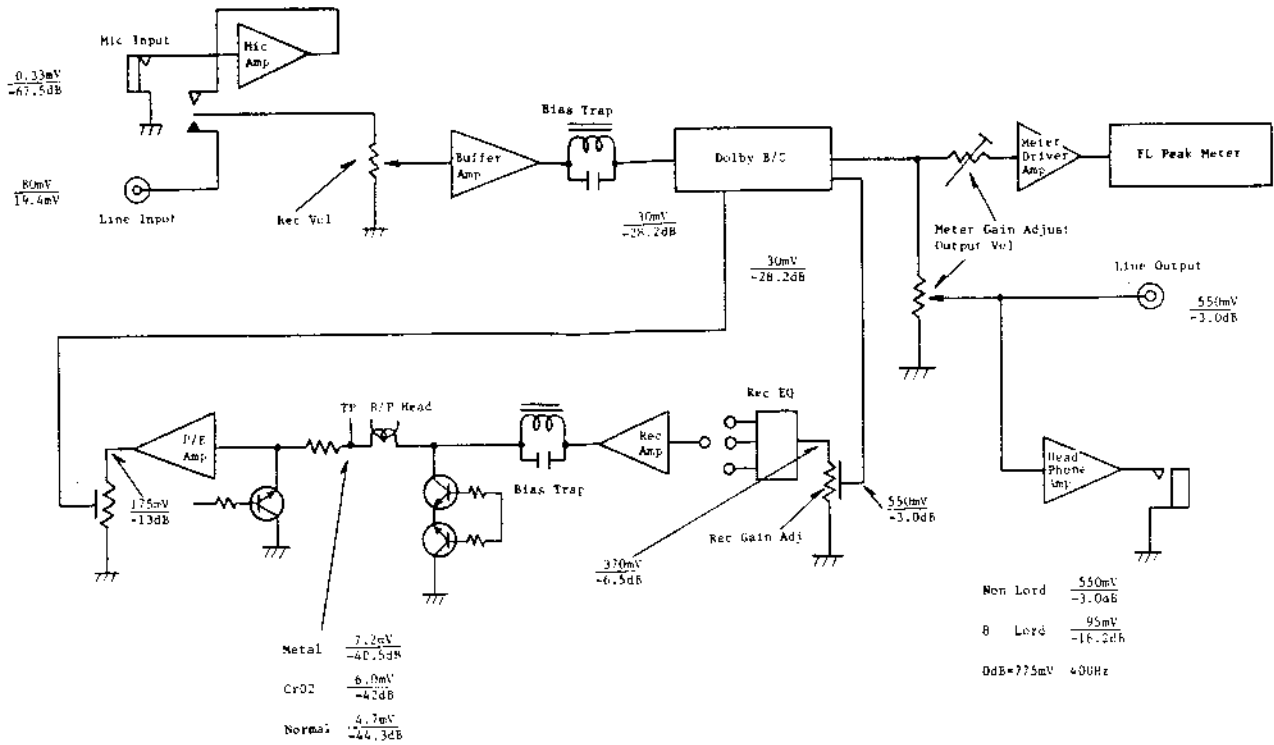

Adjustment of Location

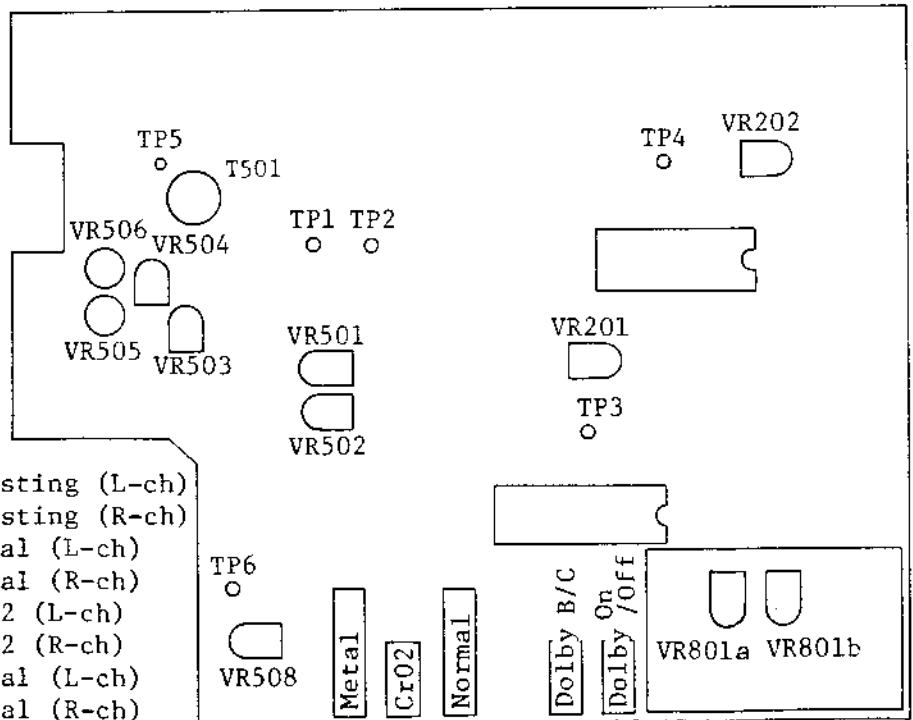





- VR201 Play Back Dolby Level Adjusting (L-ch)
- VR202 Play Back Dolby Level Adjusting (R-ch)
- VR501 Record Level Adjusting, Metal (L-ch)
- VR502 Record Level Adjusting, Metal (R-ch)
- VR503 Bias Current Adjusting, CrO2 (L-ch)
- VR504 Bias Current Adjusting, CrO2 (R-ch)
- VR505 Bias Current Adjusting, Metal (L-ch)
- VR506 Bias Current Adjusting, Metal (R-ch)
- VR508 Bias Current Adjusting, Normal (L/R-ch)
- VR801a FL Meter Adjusting (L-ch)
- VR801b FL Meter Adjusting (R-ch)

T501 Bias OSC Frequency Adjusting

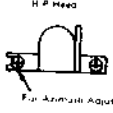
K-230

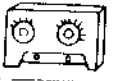
Adjustment Procedures

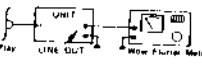
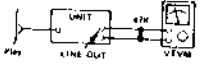
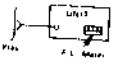
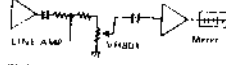
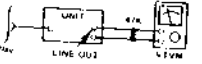
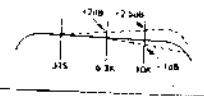
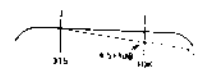
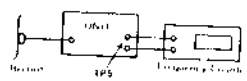
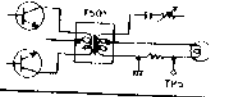
Step	Description	Mode	Adjusting Point	Test Point	Connection	Remarks	
1	Tape Transportation Check	Play	 H.P. Head For Azimuth Adjust	 Cassette Deck Fig. 1-1	 Head & Guide Stage (Fig. 1-10)	Make sure that does not touch the tape guide of erase and R/P heads, by using "Skew Half". Confirm that R/P head is placed without any tilt against the "M-300" gage.	
2	Torque Check	Play, FF & Rew		 Torque Meter		Take Up Torque : 35-60 g.cm Back Tension Torque : 2-6 g.cm FF & Rew Torque : 70-130g.cm	
3	Tape Speed and Wow Flutter Check	Playback	 For Speed Adjust Motor	Line Out	 UNIT LINE OUT Wow Flutter Meter	Test Tape : MTT-111 (3KHz) Speed : 3000Hz \pm 1.5% Wow Flutter : No more than 0.05% (JIS W.R.M.S.)	
4	Head Azimuth Adjustment	Playback	See [Fig. 1]	Line Out		Test Tape : MTT-114 (10KHz) or MTT-215C (315Hz, 10KHz) Line Out : Maximum of both channel	
5	Playback Dolby Level Adjustment	Playback Tape Select: Normal Dolby NR : Off	VR201 Lch VR202 Rch	Line Out	 UNIT LINE OUT VFM	Test Tape : MTT-150 (400Hz, 200nWb/m) Line Out : 550mV	
6	FL Meter Adjustment	Playback	VR801a Lch VR801b Rch	Meter Display	 UNIT FL Meter	 LINE AMP VFM801 Meter	Test Tape : MTT-150 Meter Display : 0 dB
7	Playback Frequency Response Check	Playback Tape Select: Normal Dolby NR : Off	Step 1-5	Line Out	 UNIT LINE OUT VFM	 +20dB -20dB JIS 0.3K 10K 10B	Test Tape : MTT-150 MTT-215C
		Playback Tape Select: Cr02 Dolby : Off				 +20dB -20dB 315 0.3K 10K	Test Tape : MTT-114 or MTT-215C
		Playback Tape Select: Metal Dolby NR : Off					
8	Bias OSC Frequency Response Check	Record Tape Select: Metal Dolby : Off	T501	TP5-GND	 UNIT TP5 Frequency Counter	 F501 TP5	Input : Non TP Output : 105kHz \pm 5KHz 220mV \pm 20mV

Step	Description	Mode	Adjusting Point	Test Point	Connection	Remarks
9	Bias Current Adjustmecn	Record Tape Select: Metal Dolby NR : Off	VR505 Lch VR506 Rch	TP1-GND TP2-GND		Input : Non TP Output : 85mV
		Record Tape Select: Cr02 Dolby NR : Off	VR503 Lch VR504 Rch			Input : Non TP Output : 46mV
		Record Tape Select: Normal Dolby NR : Off	VR508 L/Rch			Input : Non TP Output : 30mV
10	Input Level Adjustment	Record Tape Select: Normal Dolby NR : Off	Rec Level VR	Line Out		Input : 80mV 400Hz Line Out : 550mV
11	Record Level Adjustment and Check	Record/Play Tape Select: Metal Dolby NR : Off	VR501 Lch VR502 Rch	Line Out		Input : 80mV 400Hz Line Out : 550mV
		Record/Play Tape Select: Cr02 Dolby NR : Off				
		Record/Play Tape Select: Normal Dolby NR : Off				
12	Record/Playback Frequency Response Check	Record/Play Tape Select: Metal Dolby NR : Off	Step 8-11	Line Out		
		Record/Play Tape Select: Cr02 Dolby NR : Off				
		Record/Play Tape Select: Normal Dolby NR : Off				
13	Record/Playback Frequency Response Check (Dolby)	Record/Play Tape Select: M.C.N. Dolby NR : B,C				

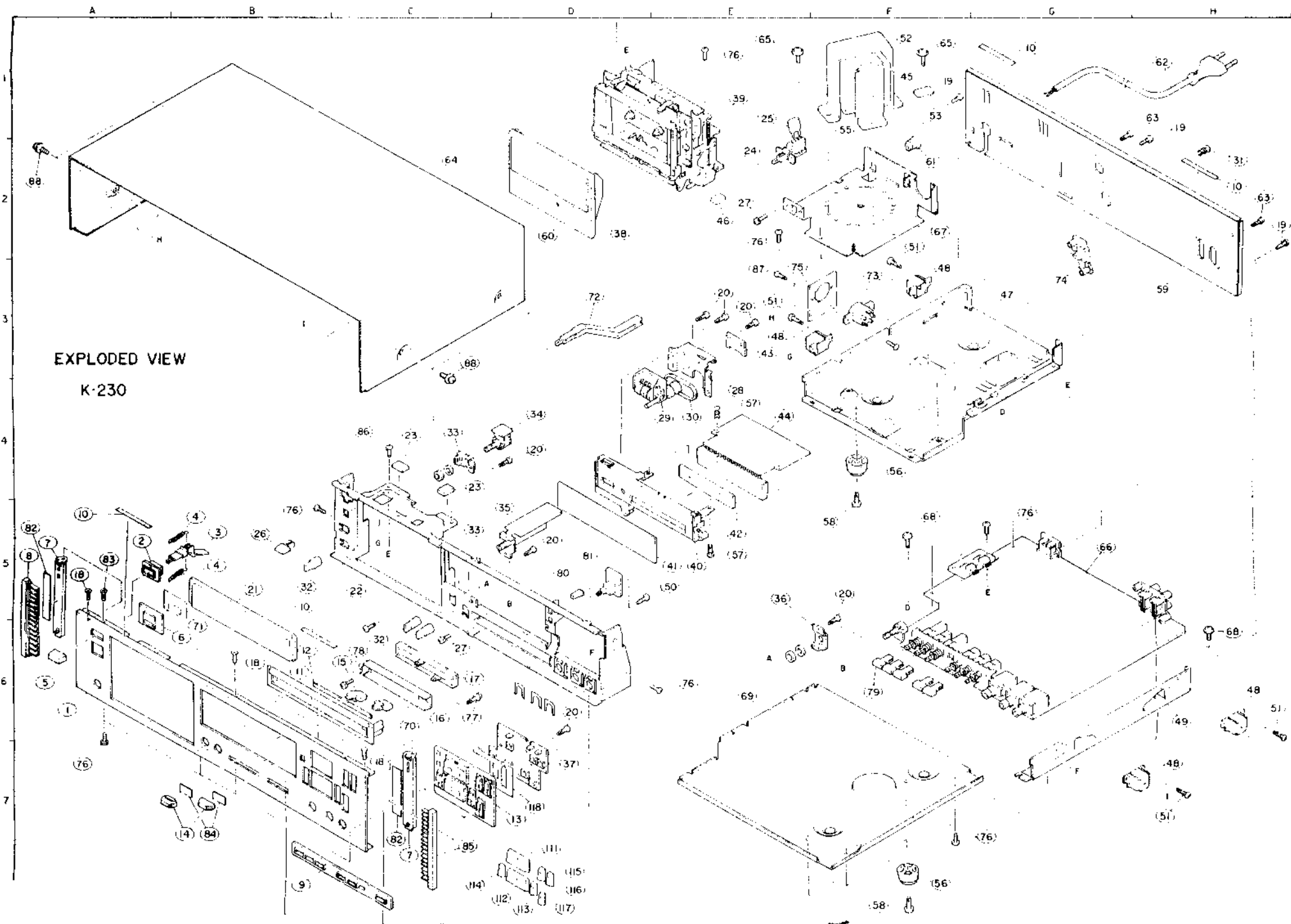

EXPLODED VIEW
K-230

Exploded View Parts List

Index	Symbol No.	Stock No.	Description	Remarks
A6	1	64D57162F01	Panel, Front	
A5	2	07A45558F04	Frame, Eject	
B5	3	45A50461F01	Lever, Eject	
B5	4	41A45559F01	Spring, Eject	
A6	5	36A44340F05	Knob, Eject	
B6	6	61A56641F01	Crystal, Indicator	
A5, C7	7	07A57175F01	Bkt, Side Panel	
A5	8	07B56624F01	Frame, Side Panel	
B7	9	07B57171F01	Frame, Push Knob	
A5, G1	10	75B44632G04	Pad, Cushion	
B6	11	13C57168F01	Escutcheon, Vol	
B6	12	43A57191F01	Spacer, Escutcheon	
D7	13	07C57172F01	Frame, Knob Logic	
B7	14	36B57177F01	Knob, Control	
C6	15	43B57179F01	Spacer, Knob Cont "B"	
C6	16	07B57169F01	Bkt, Slide VR	
C6	17	18T52629F01	VR Slide, 20K	
A5, C7	18	03S44205G26	Scr, T-Tite M3x6	
F1, H1	19	03S44205G40	Scr, T-Tite M3x4	
D5, E3	20	03S40012G03	Scr, Tpg M3x6	
B5	21	61B57222F01	Crystal, Meter	
C5	22	27D57163F01	Chassis, Front	
C4	23	75A42565P15	Cushion, Rubber	
E2	24	40T45561F02	SW, Power (SDL1P)	(SK, SG, EK)
		40T47454F01	SW, Power (SDL1P)	(UP)
E1	25	08T57437F09	Cap, DE7150 FZ103P	
		43T53136F01	Bush, Cap TP150-301	
B5	26	36A56639F02	Knob, Push 1171	
C6, E2	27	03C40014G04	Scr, Mch M3x6	
E4	28	07B57165F01	Bkt, Counter	
E4	29	72T57221F01	Tape, Counter	
E4	30	42A57223F01	Belt, Counter	
H2	31	05B41635J02	Rivet, Push	
B5, C5	32	36A57190F01	Knob, Rotary	
C4, C5	33	07A50281F01	Bkt, Volume	
D4	34	01V58500F31	Ass'y, Out Put VR	
D5	35	01V58500F36	Ass'y, Rotary SW	
E5	36	07A52464F01	Bkt, Bias VR	
D7	37	01V58500F44	Ass'y, Keyboard SW	
D2	38	64B57188F01	Plate Door	
E1	39	01U46000F81	FL87E01A CAS T/DK	
E5	40	07C57182F01	Frame, Meter	
E5	41	91A57164F01	Filter, Meter (A)	
E5	42	91A57184F01	Filter, Meter (B)	
E3	43	01V58500F63	Ass'y, Reed SW	
E4	44	01V58500F34	Ass'y, FL Meter PCB	
F1	45	75A42565P16	Cushion, Rubber	
E2	46	75A42565P14	Cushion, 2x5x20	
G3	47	27C44535F01	Chassis, Bottom	
E4, F3	48	07A57185F01	Bkt, Side	
H6	49	27C44329F01	Chassis, Side	
E5	50	05B41635J02	Rivet, Push	
E3	51	03S44205G12	Scr, T-Tite M3x4	
F1	52	07A45749F01	Support, Trans	(U)

Index	Symbol No.	Stock No.	Description	Remarks
F1	53	07A40871F01	Support, Trans Washer	
F1	55	25T53363F01	Trans, Power	(SK)
		25T55507F01	Trans, Power	(SG, EK)
		25T53364F01	Trans, Power	(UP)
F7, F4	56	75A52969F01	Pad, Trans-Leg	
E5	57	05B41635J03	Scr, T-Tite M3x4	
F7, F5	58	03S40036U02	Scr, T-Tite M3x8	
H3	59	15C53244F08	Cover, Rear	(SK, EK, UP)
		15C53244F10	Cover, Rear	(SG)
D2	60	61C57187F01	Crystal, Door	
F2	61	43B41625J02	Support, Cord	(SK, EK)
		43B41625J01	Stopper, Cord	(UP)
H1	62	28T43812P02	Plug, AC Cord	(SK)
		30T43811F01	Cord, AC 3 Reed	(SG)
		28T50179F03	AC, Cord	(EK)
		28T40916U01	Plug, AC Cord	(UP)
H2, H1	63	03S40012G41	Scr, Tpg M3x8	
C2	64	15D57189F01	Cover, Top	
E1, F1	65	03S40036U07	Scr, T-Tite M4x12	
G5	66	01V58500F61	Ass'y, Master Board	(SK, SG)
		01V58700F46	Ass'y, Master Board	(EK, UP)
F2	67	07B45445F01	Bkt, Trans	(SK, EK)
		07B45445F02	Bkt, Trans	(UP)
		07B45445F03	Bkt, Trans	(SG)
F5, H6	68	03C42723U01	Scr, Cup M3x6	
E6	69	15C44331F01	Cover, Bottom	
C6	70	43B57178F01	Spacer, Knob Cont "A"	
B6	71	43A56628F01	Spacer, Power	
D3	72	45B57186F01	Lever, Knob	
F3	73	40T40705T04	SW, Select	(SG, EK)
G3	74	09T57205F01	Plate, Phono 1P T5538	
E3	75	07A57583F01	Bkt, Select SW	(SG, EK)
A7, E2	76	03S40012G03	Scr, Tpg M3x6	
C6	77	03S40018G02	Scr, Tpg M3x8	
C6	78	03C40014G12	Scr, Mch M2.6x4	
F6	79	36A57176F01	Knob, Push (A)	
D5	80	36A57180F01	Knob, Push (B)	
D5	81	01V58500F37	Ass'y, Memory SW	
A5, C7	82	14S53018F52	Insulator, 50x12	
A5	83	03S40012G26	Scr, Tpg M3x6	
A7	84	75A57370F01	Pad, Cushion	
C7	85	07B56624F02	Frame, Panel Side	
C4	86	03S40012G81	Scr, Tpg M3x5 (Flat)	
E3	87	03S44205G01	Scr, T-Tite M3x6	(SG, EK)
A2, C3	88	03S41635J03	Scr, T-Tite M4x8	
C7	111	36B57173F01	Knob, Logic (Play)	
C7	112	36B57173F02	Knob, Logic (Stop)	
C7	113	36A57174F01	Knob, Logic (F.F.)	
C7	114	36A57174F02	Knob, Logic (REW)	
C7	115	36A57174F03	Knob, Logic (PAUSE)	
C7	116	36A57174F04	Knob, Logic (REC)	
C7	117	36A57174F05	Knob, Logic (RECMUTE)	
C7	118	07A57192F01	Bkt, Stopper	

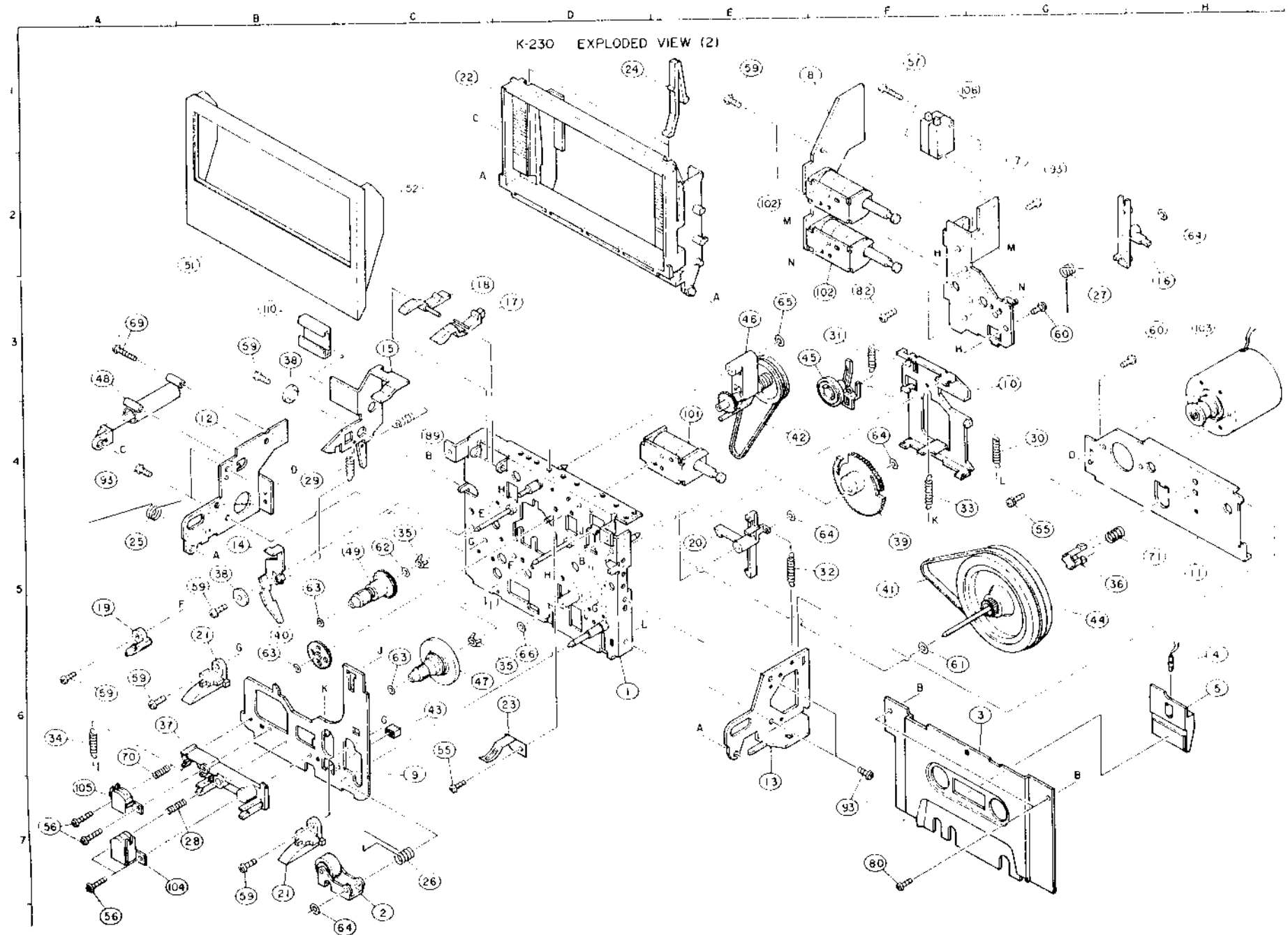

Exploded View Parts List (Mechanism)

Index	Symbol No.	Stock No.	Description
D6	1	F011-106	Ass'y, Chassis
C7	2	F014-053	Ass'y, Pinchroller
G6	3	15B44924F05	Cover, Dust
H6	4	65C42544U04	Lamp, Pilot 14V-50mA
H6	5	61A44936F01	Lens, Indicator
		43A41728U09	Bush, Lamp
G2	7	F214-011	Ass'y, Solenoid Bkt.
F1	8	F217-011	Ass'y, Connector Panel
C7	9	FR345-12	Base, Assist
G3	10	FR346-11	Base, Assist
H5	11	FR347-12	Bkt., Motor
B4	12	FR349-13	Bkt., Dumper
E7	13	FR350-12	Bkt., Door
B5	14	FR352-11	Lever, Safety
C3	15	FC11H-12	Arm, Eject Lock
H3	16	FR355-12	Arm, FF Solenoid
D3	17	FR356-14	Arm, SW
C3	18	FD17T-12	Arm, Record
A5	19	FR358-12	Guide, Reference
E5	20	FR359-12	Arm, Play Solenoid
B5, B7	21	FR360-12	Guide, Cassette
C1	22	FD19L-12	Frame, Door
D6	23	FK551-13	Spring, Cassette
E1	24	FK553-12	Spring, Hold
A5	25	FK568-11	Spring, Door
C7	26	FK569-13	Spring, Pinchroller
G3	27	FK570-12	Spring, Sol. Bkt.
B7	28	FK572-11	Spring, Azimuth
B4	29	FK573-11	Spring, Arm Lock
G4	30	FK574-12	Spring, Assist Base
F3	31	FK575-11	Spring, Play Idler
F5	32	FK576-12	Spring, Play Sol. Arm
F4	33	FK577-12	Spring, Head Base
A6	34	FK578-13	Spring, Head Base Hold
C5,	35	FK579-11	Spring, Back Tension
G5	36	FM281-11	Spacer, Flywheel
A6	37	FM283-13	Spacer, Head
B3, B5	38	FM296-11	Spacer

Index	Symbol No.	Stock No.	Description
F5	39	FN153-11	Gear, Play
B5	40	FN154-13	Gear, Idler
F5	41	FP462-11	Belt, Main
E4	42	FP463-11	Belt, Sub
C6	43	FP464-11	Pad, Cushion
G5	44	FP467-11	Ass'y, Flywheel
E3	45	FP469-12	Ass'y, Idler
E3	46	FP470-11	Ass'y, Clutch
C6	47	FR12N-11	Ass'y, Take Up Reel
A3	48	FP472-11	Ass'y, Dumper
C5	49	FR12P-11	Ass'y, Supply Reel
B2	51	61C57187F01	Crystal, Door
C2	52	64B57188F01	Plate, Door
C6, G5	55	FG114-15	Scr, Cup
A7	56	FG137-15	Scr, F-lock M2
F1	57	FG143-26	Scr, Mch. M2.6x15
A6, B3	59	KG194-12	Scr, T-Tite M3x0
G3, H3	60	KG194-46	Scr, T-Tite M3x4
F6	61	FJ111-12	Poly-Slider ϕ 2.1x0.5
C5	62	FJ111-19	poly-Slider ϕ 2x0.13
B5, B6	63	FJ123-14	Wsr., Lock ϕ 17
B7, F4	64	FJ123-21	Wsr., Lock ϕ 2.6
E3	65	FJ123-19	Wsr., Lock ϕ 3.5
D6	66	FJ141-12	Oil Seal
A3	69	UG11D-11	Scr, T-Tite
A6	70	FK572-12	Spring, Azimuth
H5	71	FK11F-16	Spring, Thrust
F7	80	03S40036U03	Scr, T-Tite M3x6
F3	82	FG143-17	Scr, Mch. M2.6x3
C4	89	FK11C-11	Spring, Brake Arm
A4, F7	93	KG189-11	Scr, Mch. M3x5
E4	101	F024-036	Ass'y, Solenoid
E2, F3	102	PBC16062	Solenoid
H3	103	F064-074	Ass'y, Motor
A7	104	F029-090	Ass'y, R/P Head
A7	105	F030-052	Ass'y, E Head
G1	106	FE173-11	SW, Slide
B3	110	43A51937F01	Spacer, Eject

Master Board PCB Parts List

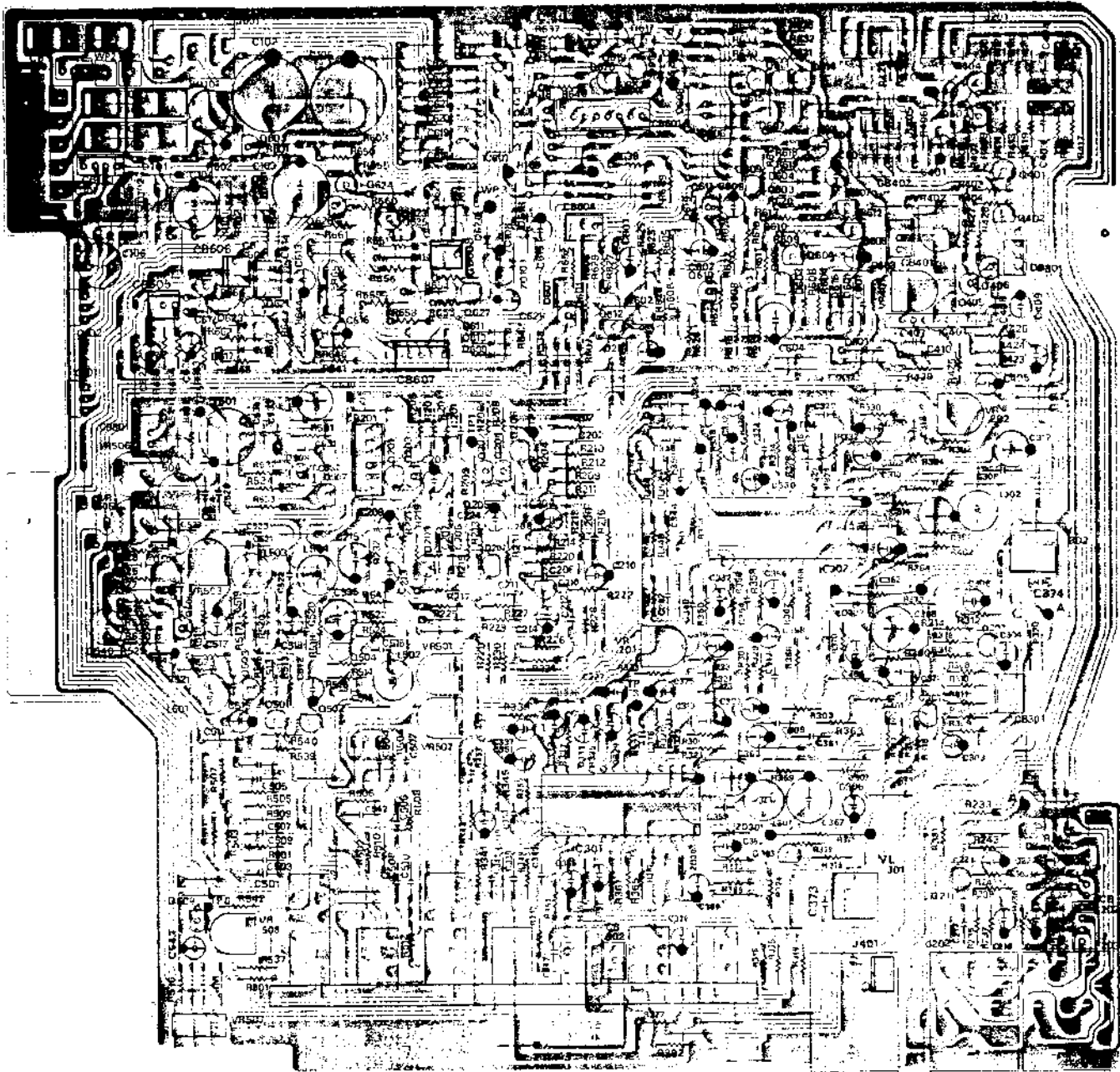

Symbol No.	Stock No.	Description
(Terminal & Jack)		
J201	09T50231F02	Plate, Phone 4P
J202,203	09T55174F02	Jack, Mic Metal-6.5
J401	09T55174F12	Jack, Mic Metal-6.5
J601	09T50261F01	Jack, Cont
(Variable Resistor)		
VR201,202	18T52946F17	47K PB Level
VR501,502	18T52946F15	22K Rec Level
VR503,504	18T52946F19	100K Metal Bl.
VR505,506	18B44064J07	100K-1/2 CrO2 Film
VR507	18T52943F01	VR, Totary Bias
VR508	18T52946F09	2.2K
(Coil)		
L301,302	24747331F01	Inductor, 360P
L501,502	248341449F02	Induc, Radial, 650P
L503,504	251441997F01	Coil, Inductor, 750P
(Trans, OSC)		
T501	25152821F01	Trans, OSC

Symbol No.	Stock No.	Description
(Switch)		
S201-203	40757676F01	SW, Push, 30T
S301-303		
(Transistor)		
Q101,102	48T42620F02	2SD880-Y
Q201,202	48841196U03	2SC1980-T
Q203,204	48841196F03	2SC1980-T
Q205,206	48843525F05	2SC1815-Y,GR
Q207,208	48840246G01	2SC732 BL
Q209,210	48840246G01	2SC732 BL
Q211,212	48840246G01	2SC732 BL
Q301,302	48840246G01	2SC732 BL
Q401	48843525F05	2SC1815-Y,GR
Q401,402	48T51878F01	2SC2878 A,B
Q401,403	48T50832F04	2SC1318SC-B
Q501,502	48T51878F01	2SC2878 A,B
Q503,504	48840246G01	2SC732 BL
Q505,506	48841196U03	2SC1980-T

K-230

Symbol No.	Stock No.	Description
Q507,508	48S40832F03	2SC1318NC-R
Q509,	48T42620F02	2SD880-Y
Q601	48T40081T03	2SA733 (P)
Q602,603	48S43525F05	2SC1815-Y,GR
Q604	48T44763F01	2SB788-S
Q605,606	48S43525F05	2SC1815-Y,GR
Q607	48S43525F05	2SC1815-Y,GR
Q608	48T40081T03	2SA733 (P)
Q609	48S43525F05	2SC1815-Y,GR
Q610	48T40081T03	2SA733 (P)
Q611,612	48S43525F05	2SC1815-Y,GR
Q613,614	48S40832F04	2SC1318NC-S
Q615	48S40832F04	2SC1318NC-S
Q616,617	48S43525F05	2SC1815-Y,GR
Q618,619	48S43525F05	2SC1815-Y,GR
Q620,621	48S43525F05	2SC1815-Y,GR
Q622,623	48S43525F05	2SC1815-Y,GR
Q624,625	48S43525F05	2SC1815-Y,GR
Q626,627	48S43525F05	2SC1815-Y,GR
(Diode)		
D101	48T55186F01	GP10D
D201,301	48T51582F01	MA-150
D501,502	48T51582F01	MA-150
D601	48T53429F01	1SS81
D602,603	48T51582F01	MA-150
D604,605	48T51582F01	MA-150
D606,607	48T55186F01	GP10D
D608	48T55186F01	GP10D
D609,610	48T51582F01	MA-150
D611,612	48T51582F01	MA-150
D613,614	48T51582F01	MA-150
D615	48T55186F01	GP10D
D616,617	48T51582F01	MA-150
D618,619	48T51582F01	MA-150
D620,621	48T51582F01	MA-150
D622,623	48T51582F01	MA-150
(Diode,Bridge)		
BD101	48T50629F01	WL-02
(Coil)		
VL301,302	24T51803F01	Coil,Trap 4.7MH
(IC)		
IC301,302	51T52160F01	HA12038-01
IC601	51S47110F01	BA843
(Holder,Fuse)		
F101-103	09T45548F01	Holder,Fuse (SK,SG)
(Fuse)		
F101	65T42077U15	Fuse,Semko T 800MA (SK,SG)
F102	65T42077U15	Fuse,Semko T 800MA (SK,SG)
F103	65T42077U12	Fuse,Semko T 400MA (SK,SG)
(Zener,Diode)		
ZD101	48T52739F86	HZ20-2
ZD102	48T52739F75	HZ128-3
ZD103	48T52739F38	HZ6B-2
ZD301,302	48T52740F08	HZ12C-2
ZD303	48T52739F38	HZ6B-2
(Capacitor)		
C101	23S40657F28	1uF 50V E1
C102	23S41198U67	1000uF 50V E1
C103	23S41198U57	470uF 25V E1
C104	23S41198U42	220uF 25V E1
C105	23S41198U72	2200uF 25V E1
C106	23S41198U56	470uF 16V E1
C107	23S40657F14	100uF 16V E1
C108	23S40657F08	100uF 10V E1
C201,202	08S44505P44	390uF Ce
C203,204	23T42478F09	4.7uF 25V LN E1
C205,206	08S44505P45	470pF Ce
C207,208	08S44505P29	47pF Ce
C209,210	23S40657F07	47uF 10V E1
C211,212	08S40656F08	0.0039uF My
C213,214	23S40657F17	10uF 25V E1
C215	23S40657F21	100uF 25V E1
C216	23S40657F16	4.7uF 25V E1

Symbol No.	Stock No.	Description
C217,218	08S44505P49	1000pF Ce
C219,220	23T42478F09	4.7uF 25V LN E1
C221,222	23S40657F17	10uF 25V E1
C224	23S40657F10	10uF 16V E1
C301,302	23S40657F28	1uF 50V E1
C303,304	23S40657F28	1uF 50V E1
C305,306	23S40657F10	10uF 16V E1
C307,308	08S44505P50	1200pF Ce
C309,310	08S44505P41	220pF Ce
C311,312	23S40657F08	100uF 10V E1
C313,314	23S40657F09	220uF 10V E1
C315,316	08S40656F15	0.015uF My
C317,318	08S40656F15	0.015uF My
C319,320	23S40657F10	10uF 16V E1
C321,322	08S40656F13	0.01uF My
C323,324	08S40656F16	0.018uF My
C325,326	23S40657F16	4.7uF 25V E1
C327,328	23T42478F21	0.33uF 50V LN E1
C329,330	23T42478F21	0.33uF 50V LN E1
C331,332	23S40657F28	1uF 50V E1
C333,334	23S40657F28	1uF 50V E1
C337,338	23S40657F10	10uF 16V E1
C339,340	08S44505P27	39pF Ce
C341,342	08S44505P49	1000pF Ce
C343,344	08S40656F10	0.0056uF My
C345,346	08S40656F07	0.0033uF My
C347,348	08S40656F08	0.0039uF My
C349,350	23S40657F10	10uF 16V E1
C351,352	23S40657F16	4.7uF 25V E1
C353,354	08S40656F24	0.082uF My
C355,356	23T42478F19	0.15uF 50V E1
C357,358	23S40657F27	0.47uF 50V E1
C359,360	08S40656F04	0.0018uF My
C363,364	23S40657F10	10uF 16V E1
C365,366	23S40657F11	22uF 16V E1
C367,368	23S40657F52	220uF 16V E1
C369	23S40657F13	47uF 16V E1
C371	23S40657F13	47uF 16V E1
C373,374	08T44481F05	0.00047uF Pp
C401,402	23S40657F29	2.2uF 50V E1
C403,404	23S40657F09	220uF 10V E1
C411,412	21C45322G20	68uF 50V E1
C501,502	08S44505P52	1800pF Ce
C503,504	08S44505P54	2700pF Ce
C505,506	08S44505P45	470pF Ce
C507,508	08S44505P44	390pF Ce
C509,510	08S44505P51	1500pF Ce
C511,512	23S40657F16	4.7uF 25V E1
C513,514	08S40656F25	0.1uF My
C515,516	08S40656F13	0.01uF My
C517,518	23S40657F16	4.7uF 25V E1
C519,520	08S44505P43	330pF Ce
C521,522	08S44505P35	82pF Ce
C523,524	08S44505P49	1000pF Ce
C525,526	08S44505P49	1000pF Ce
C527,528	08S44505P37	100pF Ce
C529	08T52448F21	0.0022uF Pp
C530	23S40657F21	100uF 25V E1
C531	08S40656F13	0.01uF My
C532,533	08S40656F07	0.0033uF My
C534	08S40656F13	0.01uF My
C535	23S41198U42	220uF 25V E1
C540	23S40657F19	33uF 25V E1
C541,542	08S44505P45	470pF Ce
C543	23S40657F18	22uF 25V E1
C601	08S44505P61	10000pF CE
C602	23S40657F28	1uF 50V E1
C603	23S40657F16	4.7uF 25V E1
C604	23S40657F21	100uF 25V E1
C605	23S40657F16	4.7uF 25V E1
C606	23S40657F17	10uF 25V E1
C607	23S40657F28	1uF 50V E1
C608	23S40657F17	10uF 25V E1

K-230

Symbol No.	Stock No.	Description
C609	23S40657F13	47uF 16V E1
C610	23S40657F13	47uF 16V E1
C611	23S40657F10	10uF 16V E1
C612	23S40657F10	10uF 16V E1
C613	23S40657F10	10uF 16V E1
C614	08S44505P61	10000pF Ce
C615	23S40657F07	47uF 10V E1
C616	23S40657F09	220uF 10V E1
C617	08S44505P61	10000pF Ce
C618	08S44505P61	10000pF Ce
C619	08S44505P61	10000pF Ce
C620	08S44505P61	10000pF Ce
C621	08S44505P61	10000pF Ce
C622	08S44505P61	10000pF Ce
C623	08S40656F25	0.1uF My
C624	08S44505P61	10000pF Ce
C625	23S40657F07	47uF 10V E1
C626	23S40657F28	1uF 50V E1
C627	23S40657F10	10uF 16V E1

(Resistor)		
Symbol No.	Stock No.	Description
R101	06S44593P75	2.7K 1/4W Rd
R102	06S44593P75	2.7K 1/4W Rd
R103	06S44593P61	680 1/4W Rd
R104	06S44593P61	680 1/4W Rd
R105	06T55179F45	150 2W Rf
R201, 202	06S44594P22	220K 1/4W Rd
R203, 204	06S44593P41	100 1/4W Rd
R205, 206	06S44593P89	10K 1/4W Rd
R207, 208	06S44593P81	4.7K 1/4W Rd
R209, 210	06S44593P89	10K 1/4W Rd
R211, 212	06S44593P89	10K 1/4W Rd
R213, 214	06S40106T14	100K 1/4W Rd
R215, 216	06S44593P45	150 1/4W Rd
R217, 218	06S40106T24	270K 1/4W Rd
R219, 220	06S44593P97	22K 1/4W Rd
R221, 222	06S44593P65	1K 1/4W Rd
R223, 224	06S44593P95	18K 1/4W Rd
R225, 226	06S44593P92	13K 1/4W Rd
R227, 228	06S44594P38	1M 1/4W Rd
R229, 230	06S44593P73	2.2K 1/4W Rd
R231	06S44593P99	27K 1/4W Rd
R232	06S44593P57	470 1/4W Rd
R233, 234	06S44593P91	12K 1/4W Rd
R235, 236	06S44593P57	470 1/4W Rd
R237, 238	06S44593P89	10K 1/4W Rd
R239, 240	06S40106T38	1M 1/4W Rd
R241, 242	06S44593P89	10K 1/4W Rd
R243, 244	06S44594P14	100K 1/4W Rd
R251, 252	06S41802P64	470K 1/4W Rd
R301, 302	06S44593P41	100 1/4W Rd
R303, 304	06S44594P14	100K 1/4W Rd
R305, 306	06S44594P08	56K 1/4W Rd
R307, 308	06S44593P41	100 1/4W Rd
R309, 310	06S44594P14	100K 1/4W Rd
R311, 312	06S44594P06	47K 1/4W Rd
R313, 314	06S40106T24	270K 1/4W Rd
R315, 316	06S44593P71	1.8K 1/4W Rd
R317, 318	06S44593P74	2.4K 1/4W Rd
R321, 322	06S44593P83	5.6K 1/4W Rd
R323, 324	06S44593P93	15K 1/4W Rd
R325, 326	06S44593P82	5.1K 1/4W Rd
R327, 328	06S44593P47	180 1/4W Rd
R329, 330	06S44593P41	100 1/4W Rd
R331, 332	06S44594P06	47K 1/4W Rd
R333, 334	06S44593P84	6.2K 1/4W Rd
R335, 336	06S44594P12	82K 1/4W Rd
R337, 338	06S44594P38	1M 1/4W Rd
R339, 340	06S44593P82	5.1K 1/4W Rd
R341, 342	06S44593P81	4.7K 1/4W Rd
R343, 344	06S44593P89	10K 1/4W Rd
R345, 346	06S44594P10	68K 1/4W Rd
R347, 348	06S44593P50	240 1/4W Rd
R349, 350	06S44593P87	8.2K 1/4W Rd

Symbol No.	Stock No.	Description
R351, 352	06S44593P49	220 1/4W Rd
R353, 354	06S44594P08	56K 1/4W Rd
R355, 356	06S44593P84	6.2K 1/4W Rd
R357, 358	06S44594P12	82K 1/4W Rd
R359, 360	06S44593P65	1K 1/4W Rd
R361, 362	06S44593P77	3.3K 1/4W Rd
R363, 364	06S44593P82	5.1K 1/4W Rd
R365, 366	06S44593P87	8.2K 1/4W Rd
R367, 368	06S44593P87	8.2K 1/4W Rd
R369, 370	06S44594P02	33K 1/4W Rd
R371, 372	06T55179F47	180 2W Rf
R373	06S44593P87	8.2K 1/4W Rd
R374	06S44593P73	2.2K 1/4W Rd
R375	06S44593P81	4.7K 1/4W Rd
R376	06S44593P83	5.6K 1/4W Rd
R377	06S44594P06	47K 1/4W Rd
R378, 379	06S44593P99	27K 1/4W Rd
R380	06S44593P57	470 1/4W Rd
R401, 402	06S44593P53	330 1/4W Rd
R403, 404	06S44593P81	4.7K 1/4W Rd
R405, 406	06S44593P55	390 1/4W Rd
R407, 408	06S44594P04	39K 1/4W Rd
R409, 410	06S44593P59	560 1/4W Rd
R411, 412	06S44593P59	560 1/4W Rd
R413, 414	06S44593P59	560 1/4W Rd
R415, 416	06S44593P37	68 1/4W Rd
R417, 418	06S44593P37	68 1/4W Rd
R419, 420	06S44593P73	2.2K 1/4W Rd
R421, 422	06S44593P65	1K 1/4W Rd
R501, 502	06S44594P01	30K 1/4W Rd
R503, 504	06S44593P99	27K 1/4W Rd
R505, 506	06S44594P04	39K 1/4W Rd
R507, 508	06S44594P24	270K 1/4W Rd
R509, 510	06S44594P08	56K 1/4W Rd
R511, 512	06S44593P99	27K 1/4W Rd
R513, 514	06S44593P99	27K 1/4W Rd
R515, 516	06S44594P14	100K 1/4W Rd
R517, 518	06S40106T40	1.2M 1/4W Rd
R519, 520	06S44593P97	22K 1/4W Rd
R521, 522	06S44593P72	2K 1/4W Rd
R523, 524	06S44593P41	100 1/4W Rd
R525, 526	06S44593P89	10K 1/4W Rd
R527, 528	06S44593P89	10K 1/4W Rd
R529, 530	06S44593P97	22K 1/4W Rd
R531, 532	06S44593P97	22K 1/4W Rd
R533, 534	06D40801G15	10 1/2W Rd
R535	06S44593P01	2.2 1/4W Rd
R536	06S44593P75	2.7K 1/4W Rd
R537	06S44593P89	10K 1/4W Rd
R538	06S44593P57	470 1/4W Rd
R539	06S44593P89	10K 1/4W Rd
R540	06S44593P89	10K 1/4W Rd
R541	06S44593P57	470 1/4W Rd
R542	06S44593P67	1.2K 1/4W Rd
R543, 544	06S41801P74	1.5M 1/4W Rd
R601	06S44593P77	3.3K 1/4W Rd
R602	06S44593P89	10K 1/4W Rd
R603	06S44593P97	22K 1/4W Rd
R604	06S44593P89	10K 1/4W Rd
R605	06S44593P89	10K 1/4W Rd
R606	06S44593P89	10K 1/4W Rd
R607	06S44593P89	10K 1/4W Rd
R608	06S44593P89	10K 1/4W Rd
R609	06S44593P81	4.7K 1/4W Rd
R610	06S44593P89	10K 1/4W Rd
R611	06S44593P97	22K 1/4W Rd
R612	06S44593P97	22K 1/4W Rd
R613	06S44594P06	47K 1/4W Rd
R614	06S44593P81	4.7K 1/4W Rd
R615	06S44593P89	10K 1/4W Rd
R616	06S44593P89	10K 1/4W Rd
R617	06S44593P89	10K 1/4W Rd
R618	06S44593P89	10K 1/4W Rd

K-230

Symbol No.	Stock No.	Description
R619	06S44593P87	8.2K 1/4W Rd
R620	06S44593P73	2.2K 1/4W Rd
R621,622	06S44593P97	22K 1/4W Rd
R623,624	06S44593P97	22K 1/4W Rd
R625,626	06S44593P97	22K 1/4W Rd
R627	06S44594P02	33K 1/4W Rd
R628	06S44593P93	15K 1/4W Rd
R629	06S44594P02	33K 1/4W Rd
R630	06S44593P59	560 1/4W Rd
R631,632	06S44593P73	2.2K 1/4W Rd
R633,634	06S44593P59	560 1/4W Rd
R635	06S44593P73	2.2K 1/4W Rd
R636,637	06S44593P89	10K 1/4W Rd
R638	06S44593P47	180 1/4W Rd
R639	06S44594P14	100K 1/4W Rd
R640	06S44593P97	22K 1/4W Rd
R641	06S44593P91	12K 1/4W Rd
R642	06S44593P85	6.8K 1/4W Rd
R643	06S44593P89	10K 1/4W Rd
R644	06S44593P93	15K 1/4W Rd

Symbol No.	Stock No.	Description
R645	06S44593P77	3.3K 1/4W Rd
R646	06S44593P93	15K 1/4W Rd
R647	06S44593P81	4.7K 1/4W Rd
R648	06S44594P06	47K 1/4W Rd
R649	06S44593P45	150 1/4W Rd
R650	06S44594P02	33K 1/4W Rd
R651	06S44594P04	39K 1/4W Rd
R652	06S44593P77	3.3K 1/4W Rd
R653	06S44594P11	75K 1/4W Rd
R654	06S44594P10	68K 1/4W Rd
R655	06S44594P06	47K 1/4W Rd
R656	06S44593P97	22K 1/4W Rd
R657	06S44594P06	47K 1/4W Rd
R658,659	06S44593P97	22K 1/4W Rd
R660	06S44594P06	47K 1/4W Rd
R661	06S44593P97	22K 1/4W Rd
R662,663	06S44593P89	10K 1/4W Rd
R664	06S44594P14	100K 1/4W Rd
R665	06S44594P06	47K 1/4W Rd
R666	06S44593P97	22K 1/4W Rd

FL Meter PCB Parts List

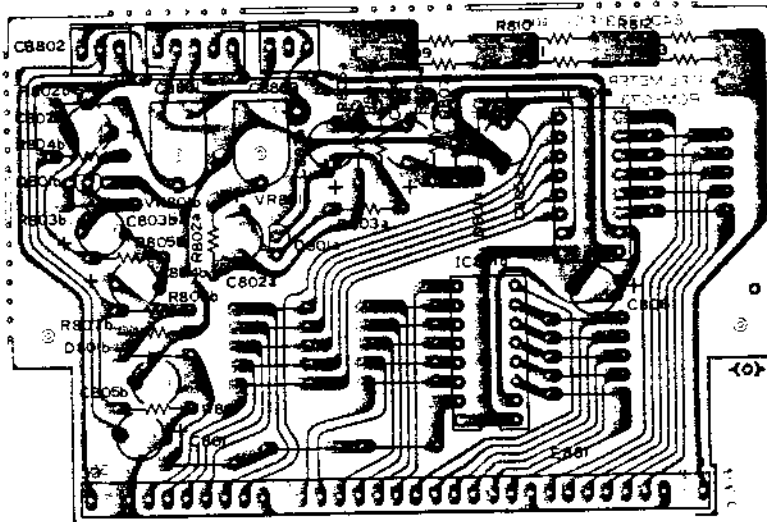

Symbol No.	Stock No.	Description
(FL Meter)		
E851	65T52950F01	FIP 12DW7YS
(Variable Resistor)		
VR801a,b	18T52946F17	47K
(IC)		
IC801a,b	51T42626F01	HA12019
(Transistor)		
Q801a,b	48S43525F05	2SC1815Y,GR
(Diode)		
D801a,b	48T43982F01	OA95 Ge.
(Capacitor)		
C801	23S40657F21	100uF 25V E1
C802a,b	23S40657F10	10uF 16V E1
C803a,b	23S40657F17	10uF 25V E1
C804a,b	23S40657F17	10uF 25V E1
C805a,b	23T42478F21	0.33uF 50V LN E1
C806	23S40657F21	100uF 25V E1

Symbol No.	Stock No.	Description
(Resistor)		
R801	06S44593P41	100 1/4W Rd
R802a,b	06S44593P89	10K 1/4W Rd
R803a,b	06S44593P29	430K 1/4W Rd
R804a,b	06S44593P71	1.8K 1/4W Rd
R805a,b	06S44594P18	150K 1/4W Rd
R806a,b	06S44594P50	3.3M 1/4W Rd
R807a,b	06S44593P85	6.8K 1/4W Rd
R808	06S44593P43	120 1/4W Rd
R809	06S44593P43	120 1/4W Rd
R810	06S44593P43	120 1/4W Rd
R811	06S44593P43	120 1/4W Rd
R812	06S44593P43	120 1/4W Rd
R813	06S44593P43	120 1/4W Rd

Out Put VR PCB Parts List

Symbol No.	Stock No.	Description
(VR Rotary)		
VR401(2)	18T47459F01	Res,Variable 5Kx2

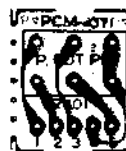

Ratary SW PCB Parts List

Symbol No.	Stock No.	Description
(Switch)		
	40T57206F01	SRZ-S 6-4
(Diode)		
D632	48S134816	S1 1S1555
D633	48S134816	S1 1S1555
D634	48S134816	S1 1S1555

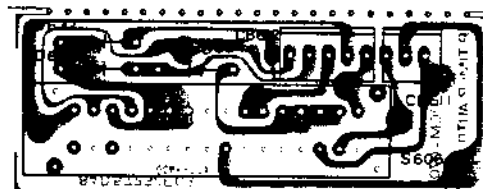

Memory SW PCB Parts List

Symbol No.	Stock No.	Description
(Switch)		
	40T57208F01	SW, Push SPH12-A
(Diode)		
D631	48S134816	S1 1S1555

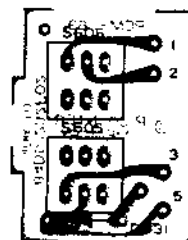

Reed SW PCB Parts List

Symbol No.	Stock No.	Description
(SW, REED)		
	40T47104F01	SW, Reed



Key Board SW PCB Parts List

Symbol No.	Stock No.	Description
(Switch)		
	40T44505F01	SW, KHG
(Diode)		
D635	48S134816	1S1555
(LED)		
	48T52238F01	BC5552K (Green)
	48T52238F02	PR5552K (Red)
(Phono, Jack)		
	09T57205F01	Plate Phono 1P

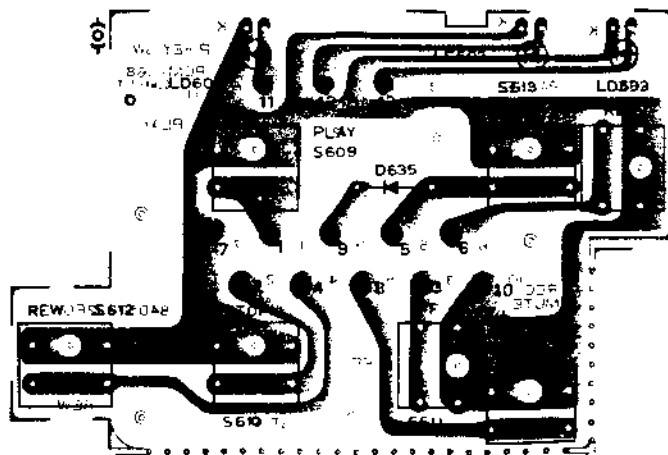

K-230

IC Handling Guide

HA12019.(IC801a,b Stock No. 51T42626F01)
 Fluorescent Tube Driver for Bar Graph Display

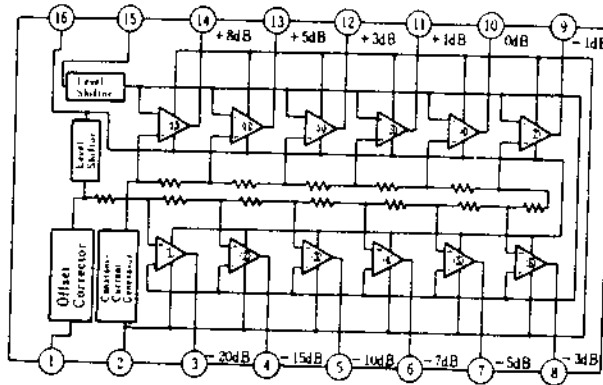

(HA12019 Block Diagram)

HA12038.(IC301,302 Stock No. 51T52160F01)
 Dolby-Band-C Type Noise Reduction System

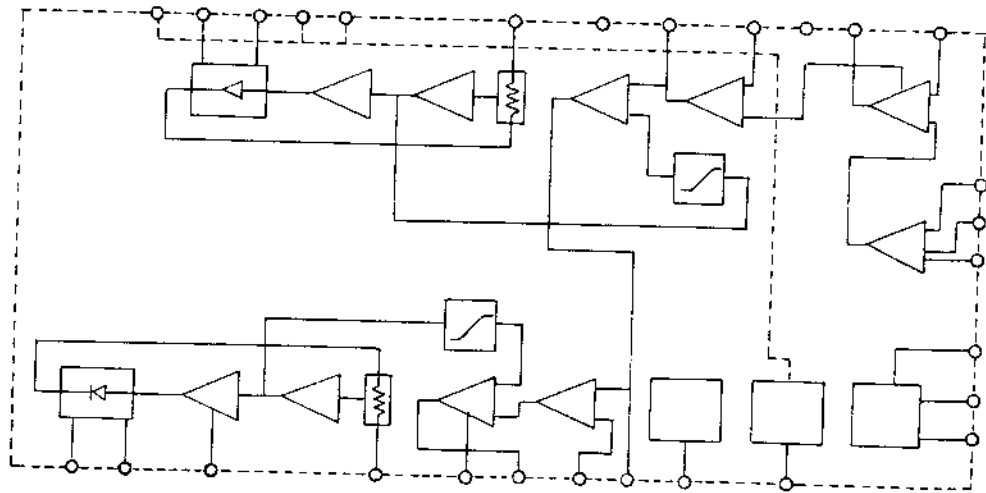

(HA12038 Block Diagram)

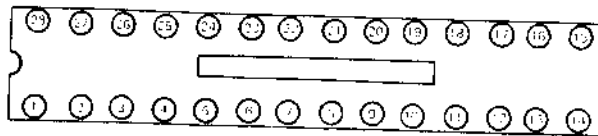

(Top View)

K-230

N-200

BA843 (IC601 Stock No. 51S47110F01)

Key Control

Block Diagram

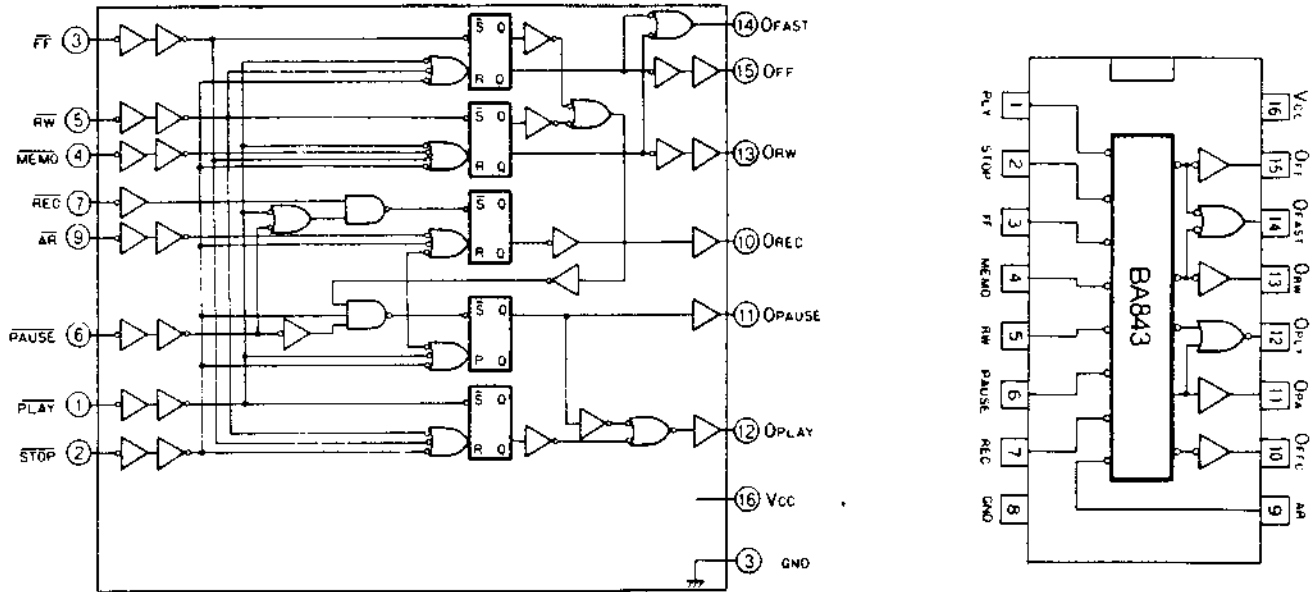

Destination's Parts List

Parts List with Specified Numbers for Designated Areas.

Symbol No.	Description	SK(220V)	SG(240V)	EK(220V)	UP(120V)
		Europe	England & Oceania	Europe	Canada
55	Power Trans.	25T53363F01	25T55507F01	25T55507F01	25T53364F01
24	SW, Power	40T45561F02	40T45561F02	40T45561F02	40T47454F01
62	AC, Cord	28T43812P02	30T43811F01	28T50179F03	28T40916U01
61	Stopper, Cord	43B41625J02	Non Use	43B41625J02	43B41625J01
67	Bkt, Trans.	07B45445F01	07B45445F03	07B45445F01	07B45445F02
59	Cover, Rear	15C53244F08	15C53244F10	15C53744F08	15C53244F08
73	SW, Selector	Non Use	40T40705T04	40T40705T04	Non Use
	Level, Serial No.	54A51740F01	54A51739F01	54A51740F01	54A56257F04
	Level, Voltage	54A44257U01	54A44257U02	54A44257U03	54A44257U10
F101, F102	Fuse	65T42077U15 (5x20 0.8A)	65T42077U15 (5x20 0.8A)	Non Use	Non Use
F103	Fuse	65T42077U12 (5x20 0.4A)	65T42077U12 (5x20 0.4A)	Non Use	Non Use
F101-F103	Holder, Fuse	09T45548F01	09T45548F01	Non Use	Non Use

LUX K-230
SCHEMATIC DIAGRAM

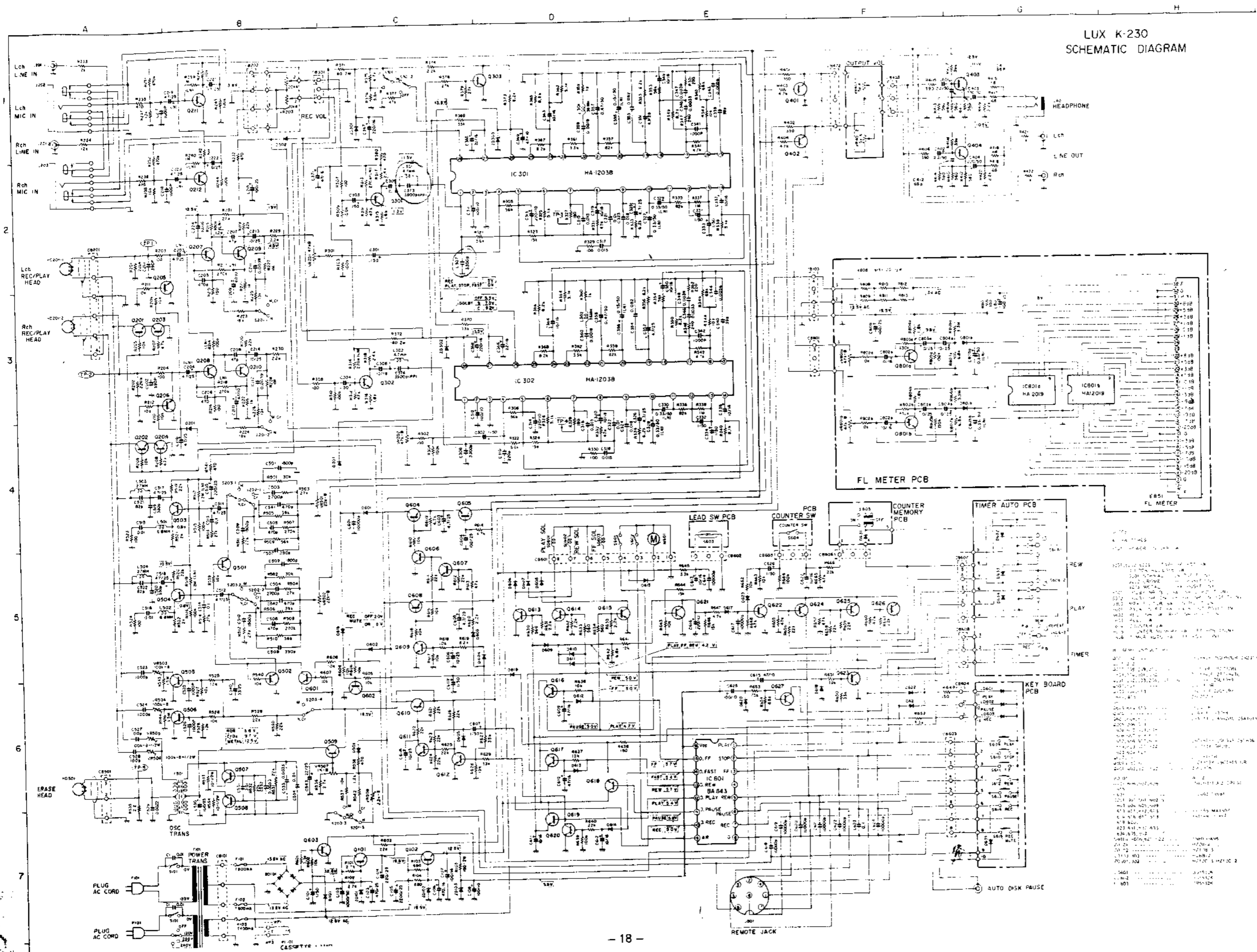

Component list table with columns for part number, description, and quantity.

Part No.	Description	Qty
Q201	2N2238	1
Q202	2N2238	1
Q203	2N2238	1
Q204	2N2238	1
Q205	2N2238	1
Q206	2N2238	1
Q207	2N2238	1
Q208	2N2238	1
Q209	2N2238	1
Q210	2N2238	1
Q211	2N2238	1
Q212	2N2238	1
Q213	2N2238	1
Q214	2N2238	1
Q215	2N2238	1
Q216	2N2238	1
Q217	2N2238	1
Q218	2N2238	1
Q219	2N2238	1
Q220	2N2238	1
Q221	2N2238	1
Q222	2N2238	1
Q223	2N2238	1
Q224	2N2238	1
Q225	2N2238	1
Q226	2N2238	1
Q227	2N2238	1
Q228	2N2238	1
Q229	2N2238	1
Q230	2N2238	1
Q231	2N2238	1
Q232	2N2238	1
Q233	2N2238	1
Q234	2N2238	1
Q235	2N2238	1
Q236	2N2238	1
Q237	2N2238	1
Q238	2N2238	1
Q239	2N2238	1
Q240	2N2238	1
Q241	2N2238	1
Q242	2N2238	1
Q243	2N2238	1
Q244	2N2238	1
Q245	2N2238	1
Q246	2N2238	1
Q247	2N2238	1
Q248	2N2238	1
Q249	2N2238	1
Q250	2N2238	1
Q251	2N2238	1
Q252	2N2238	1
Q253	2N2238	1
Q254	2N2238	1
Q255	2N2238	1
Q256	2N2238	1
Q257	2N2238	1
Q258	2N2238	1
Q259	2N2238	1
Q260	2N2238	1
Q261	2N2238	1
Q262	2N2238	1
Q263	2N2238	1
Q264	2N2238	1
Q265	2N2238	1
Q266	2N2238	1
Q267	2N2238	1
Q268	2N2238	1
Q269	2N2238	1
Q270	2N2238	1
Q271	2N2238	1
Q272	2N2238	1
Q273	2N2238	1
Q274	2N2238	1
Q275	2N2238	1
Q276	2N2238	1
Q277	2N2238	1
Q278	2N2238	1
Q279	2N2238	1
Q280	2N2238	1
Q281	2N2238	1
Q282	2N2238	1
Q283	2N2238	1
Q284	2N2238	1
Q285	2N2238	1
Q286	2N2238	1
Q287	2N2238	1
Q288	2N2238	1
Q289	2N2238	1
Q290	2N2238	1
Q291	2N2238	1
Q292	2N2238	1
Q293	2N2238	1
Q294	2N2238	1
Q295	2N2238	1
Q296	2N2238	1
Q297	2N2238	1
Q298	2N2238	1
Q299	2N2238	1
Q300	2N2238	1