

SERVICE MANUAL

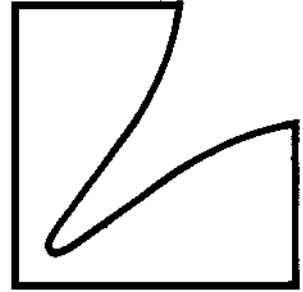

Stereo Cassette Deck **K-112**

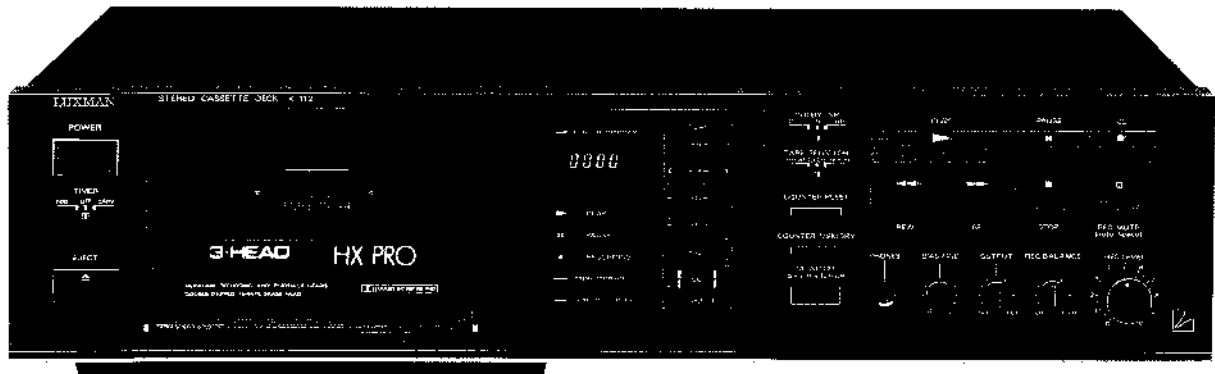

Contents

Specifications	2
Parts Locations and Disassembly Instructions	3 to 6
Adjustment Procedures	7 to 8
Block Diagram	9
Packing Assembly Parts List	10
Packing Method View	10
Parts Layout on P. C. Boards and Wiring Diagram	11 to 13
Schematic Diagram (1/2)	14 to 16
Schematic Diagram (2/2)	17 to 19
Electrical Parts List	20 to 28
Cabinet Assembly Parts List	29
EXploded View (Cabinet)	30 to 31
Exploded View (Cassette Desk)	32 to 33
Cassette Deck Assembly Parts List	34
Semi-conductor Lead Identification	35 to 38

Specifications

Power Source	AC120V, 60Hz (UC, UQ model only) AC220~240V, 50/60Hz (AD model only)
Tape Speed (MTT-111)	4.76cm/sec. $\pm 2\%$
Wow & Flutter (MTT-111, JIS WRMS)	0.1%
FF/REW Time (C-60)	105 sec.
Frequency Response (Playback, ± 4 dB)	Normal : 40Hz~14kHz CrO ₂ : 40Hz~15kHz Metal : 40Hz~16kHz
S/N Ratio (JIS weighted "A" curve)	Dolby NR-OFF : Normal 50 dB, CrO ₂ /Metal 50 dB Dolby NR-B : Normal/CrO ₂ /Metal 57 dB Dolby NR-C : Normal/CrO ₂ /Metal 63 dB
Input Sensitivity	Line : 100mV
Output Level/Impedance	Line : 500mV ± 1.5 dB/47K ohm Headphone : 100mV/8 ohm
Distortion 3rd (0 dBm input at 333Hz)	Normal/CrO ₂ : 3% Metal : 3.5%
Semiconductors	18 IC's, 52 Transistors, 40 Diodes, 5 Zener Diodes
Chassis Dimensions	438 (W) \times 110 (H) \times 318.5 (D) mm
Weight	4.3kg

NOTE : Due to continuing product improvement, specifications and design are subject to change without notice.

Parts Locations and Disassembly Instructions

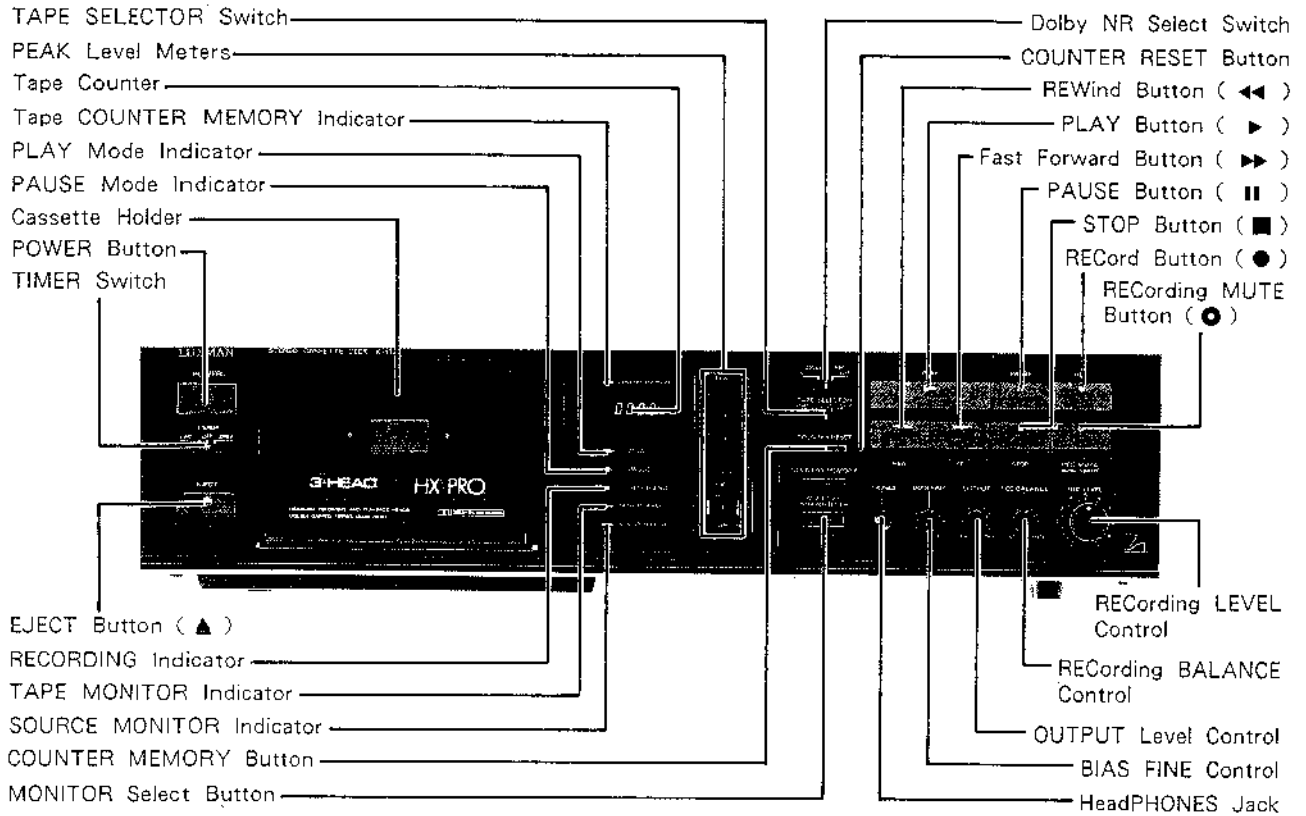

Figure 1

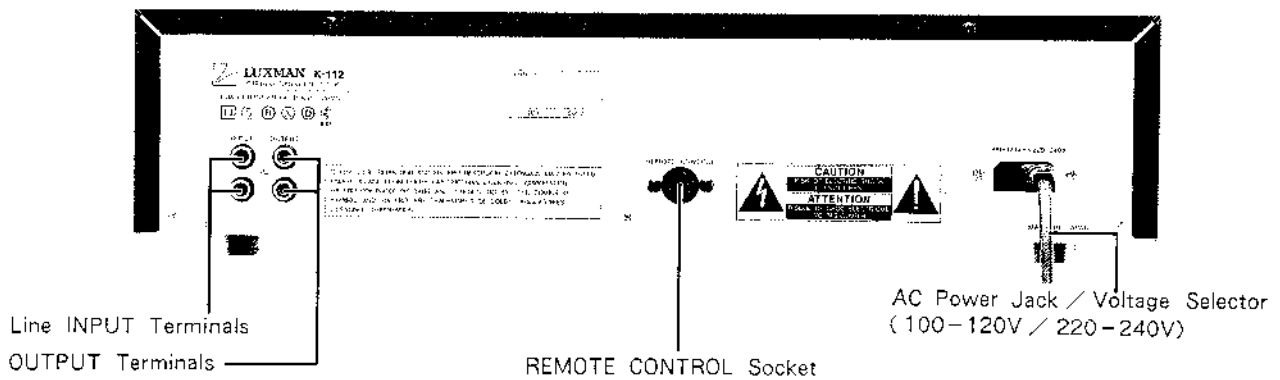

Figure 2

1. Removal of Top Cover

- (1) Remove six screws marked (A) on the rear and both sides as shown in Figure 3.
- (2) Remove the top cover by spreading and lifting it.

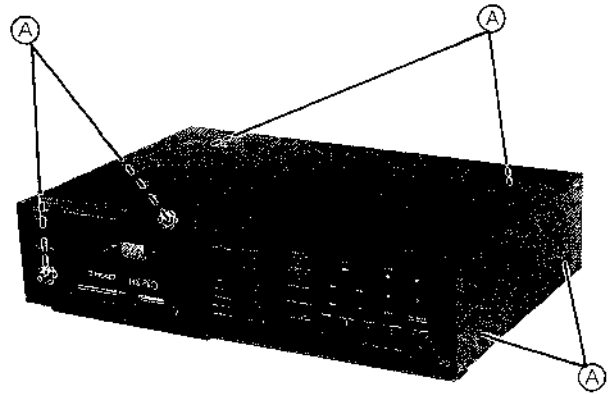

Figure 3

2. Removal of Front Panel

- (1) After removal of top cover, remove the two screws marked (B) beside the power switch as shown in Figure 4.
- (2) Remove one screw marked (C) of the timer switch as shown in Figure 4.
- (3) After removal of all connectors on the Main P. C. Board, remove six screws marked (D) on the bottom as shown in Figure 5 and remove the front panel by pulling ahead.

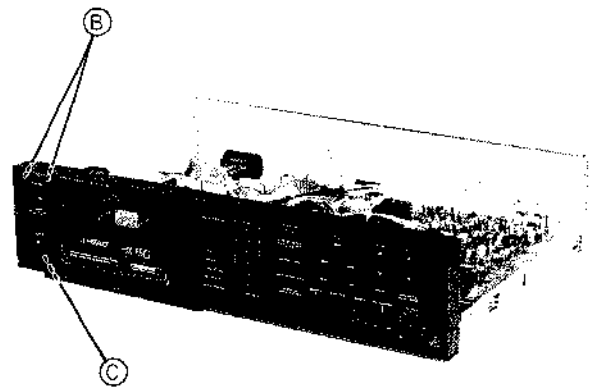

Figure 4

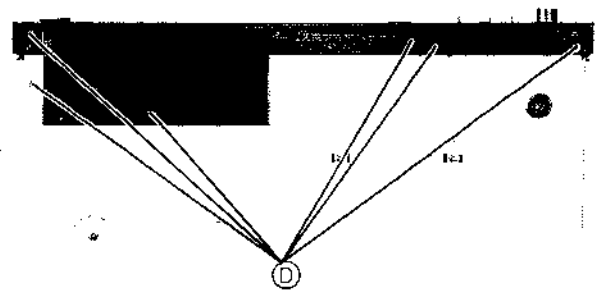

Figure 5

3-1 Removal of Cassette Mechanism.

- (1) After removal of the front panel, open the cassette door by pressing the eject button.
- (2) Remove 3P plug on LED P. C. Board and four red screws marked (E) on the mechanism as shown in Figure 6.

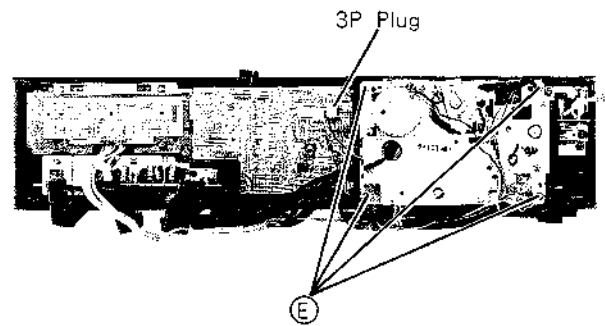

Figure 6

3-2 Removal of Operation P. C. Board

- (1) After removal of the front panel, remove two screws marked (F) on the stay bracket as shown in Figure 7.
- (2) Remove four screws marked (G) on the Operation P. C. Board as shown in Figure 7.

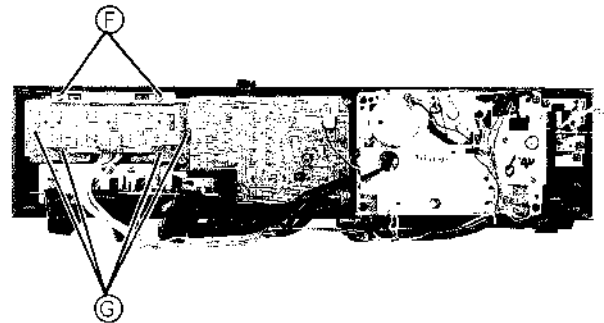

Figure 7

3-3 Removal of LED P. C. Board

- (1) After removal of Operation P. C. Board, remove four screws marked (H) on the LED P. C. Board as shown in Figure 8.

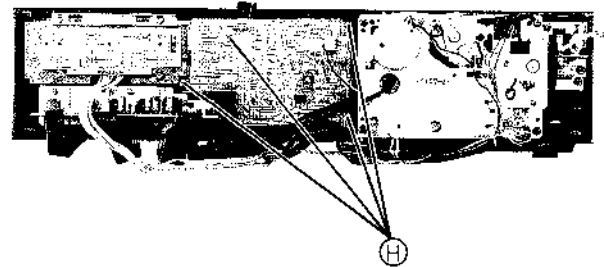

Figure 8

3-4 Removal of Volume P. C. Board

- (1) After removal of LED P. C. Board, remove two screws marked (I) of the volume bracket as shown in Figure 9.

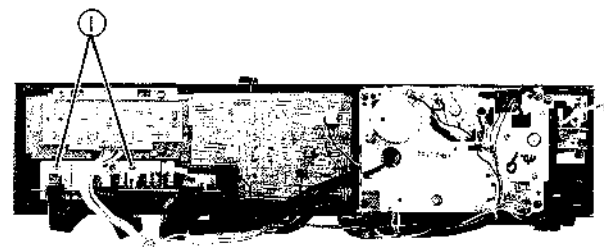

Figure 9

4. Removal of Main P. C. Board

- (1) After removal of the front panel, remove one screw marked **(K)** on the pin jack part and two rivets marked **(J)** on the remote control part as shown in Figure 10.
- (2) Release the chassis claw marked **(M)** supporting the main P. C. Board in the direction of arrow as shown in Figure 10.
- (3) Press the P. C. Board supports marked **(L)** in the direction of arrow and lift the main P. C. Board as shown in Figure 10.

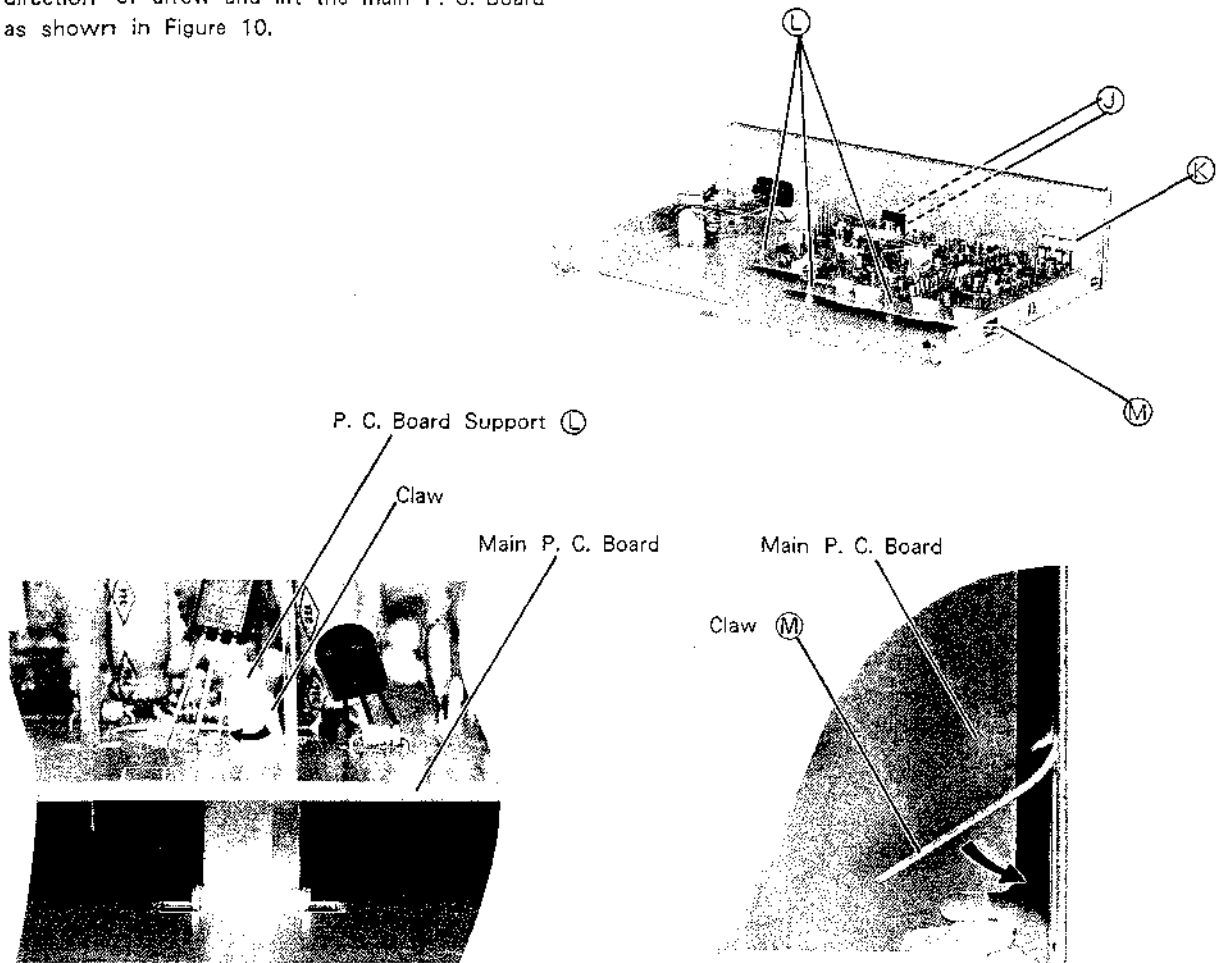

Figure 10

Adjustment Procedures

TEST EQUIPMENTS

1. VTVM (Vacuum Tube Voltmeter)
2. Signal Generator
3. Resistance Attenuator
4. Screwdriver
5. Test Tapes:
 - MTT-111 (Speed 3 kHz - 5 dB)
 - MTT-114 (Azimuth 10 kHz)
 - MTT-150 (Dolby 400 Hz Modulation)
 - AC-512 (Chrome Tape)
6. Frequency Counter

1. HEAD AZIMUTH ADJUSTMENT

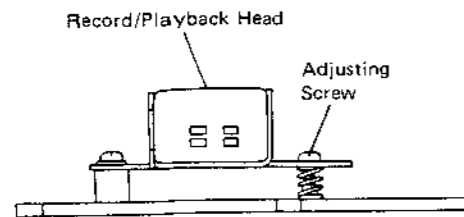

Figure 11

2. TAPE SPEED

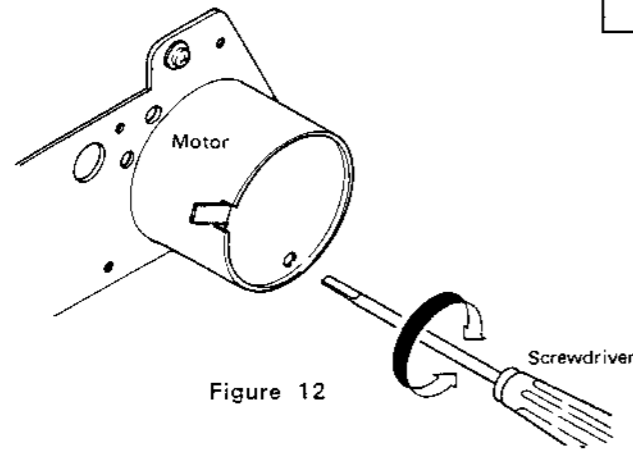

Figure 12

3. PLAYBACK SENSITIVITY ADJUSTMENT

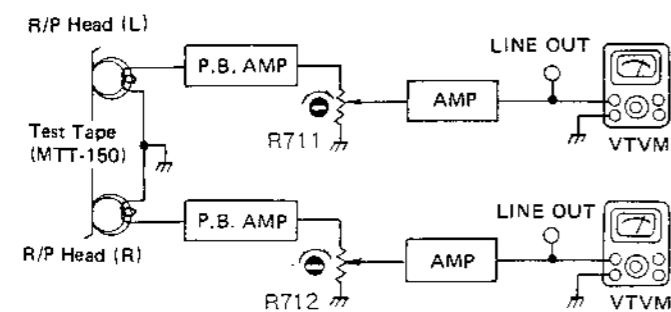

Figure 13

4. BIAS OSCILLATOR ADJUSTMENT

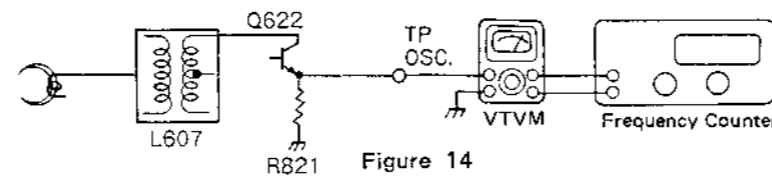

Figure 14

5. LINE INPUT SENSITIVITY ADJUSTMENT

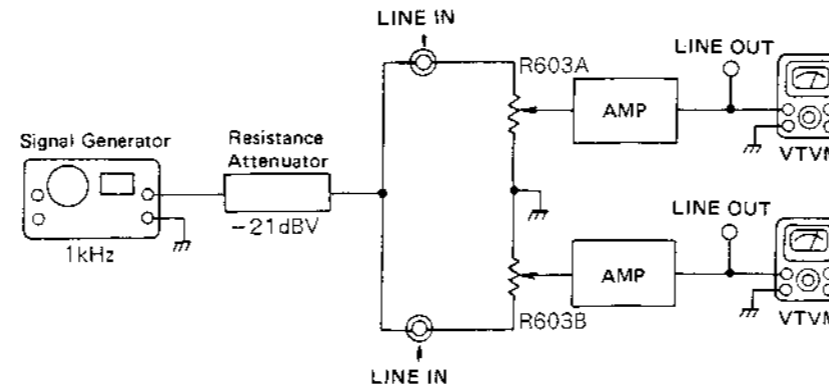

Figure 15

6. RECORD/PLAYBACK FREQUENCY ADJUSTMENT

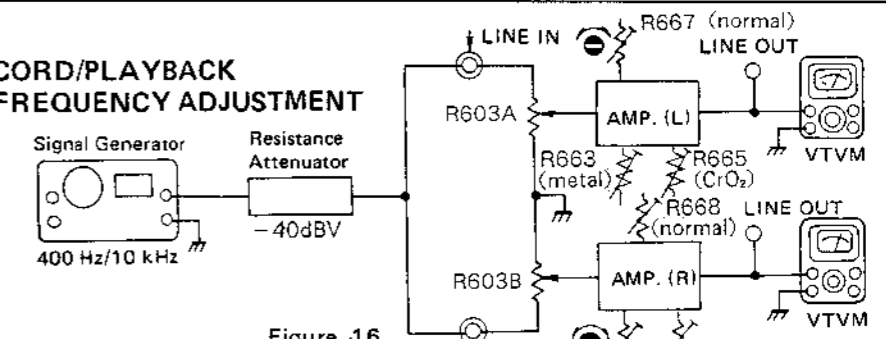

Figure 16

7. RECORD/PLAYBACK SENSITIVITY ADJUSTMENT

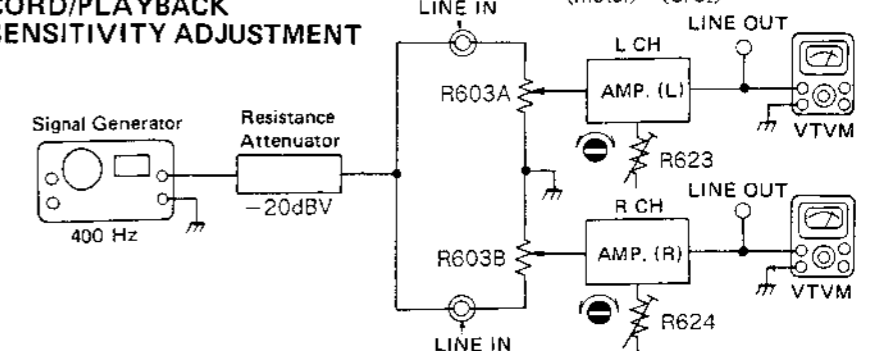
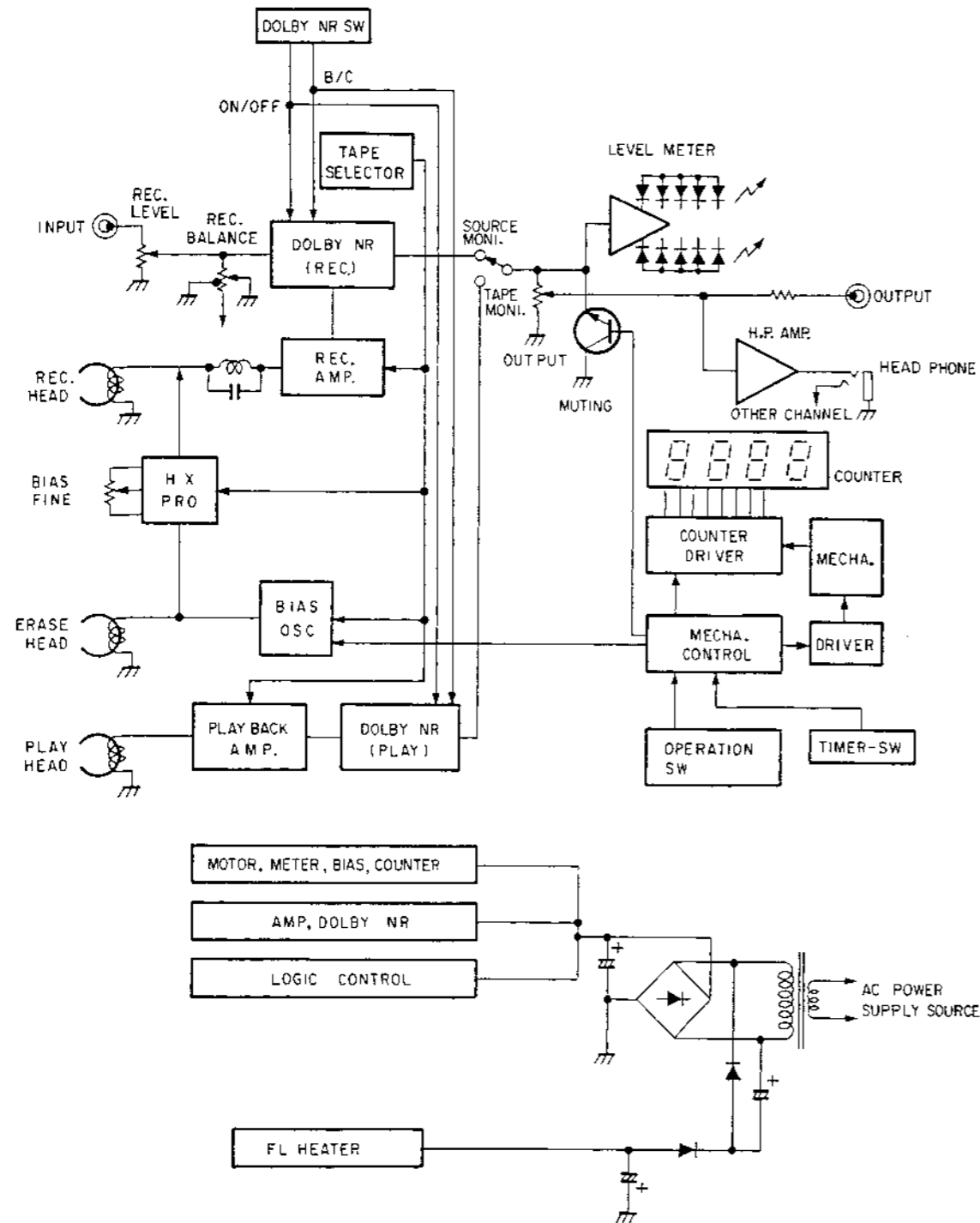

Figure 17

No.	Adjustment Item	Test Value	Test Tape	Rec. Level Control R407	Switch Position			Adjustable Parts	Test Point	Input Frequency	Connection	Remarks
					TAPE	NR	INPUT					
1	Head Azimuth Adjustment	Maximum	MTT-114		NOR	OUT		Adjusting Screw	LINE OUT	-	See Figure 11	Apply a lock paint after adjustment.
2	Tape Speed	3000 ±30 Hz	MTT-111		NOR	OUT		Internal Semifixed VR of Motor	LINE OUT	-	See Figure 12	Take-up beginning of tape.
3	Playback Sensitivity Adjustment	500 ±10mV	MTT-150		NOR	OUT		R711, 712	LINE OUT	-	See Figure 13	
4	Bias Oscillator Adjustment	105kHz	-		METAL	OUT		L607	TP OSC.	-	See Figure 14	REC
5	Line Input Sensitivity Adjustment	500 ±10mV	-	Adjustment	NOR	OUT	LINE IN	REC-VR R603A, 603B	LINE OUT	1kHz -21dB	See Figure 15	Do not vary REC-VR after adjustment.
6	Rec/PB Frequency Adjustment	0 ± 1 dB	AC-223	Adjustment	NOR	OUT	LINE IN	R667, 668	LINE OUT	400Hz 10kHz -41dB	See Figure 16	Variation of 10 kHz to 400 Hz.
			AC-512		CrO ₂			R665, 666		400Hz 10kHz -41dB		
			AC-712		METAL			R663, 664		400Hz 10kHz -21dB		
7	Rec/PB Sensitivity Adjustment	Monitor Output	AC-223	Adjustment	NOR	OUT	LINE IN	R623, 624	LINE OUT	1kHz -21dB	See Figure 17	Monitor Output : 500mV (Reference Value)
Measurement Condition <ul style="list-style-type: none"> • Power Supply: AD = 220 ~ 240V, UC, UQ = 120V • Input: 0 dB 1V rms • LINE IN (Input Impedance): 600 ohms • LINE OUT (Load Impedance): 47K ohm • Test Point Load Impedance: Non Load. 												

Block Diagram



Packing Assembly Parts List

Symbol No.	Part No.	Description	Symbol No.	Part No.	Description
101	92929660	Box-Primary	▲ 105-5	92906881	Warranty-Card
102	92939845	Tray Packing (L)	■ 105-6	92906880	Warranty-Card
103	92939846	Tray Packing (R)	■ 105-7	92906882	Reply-Card
104	92941840	Sack, Polyethylene	■ 106	92941302	Sack, Polyethylene
105	92197073	Plug, US1P-Cord	▲ 106	92941302	Sack, Polyethylene
● 105-1	92176616	Power-Cord	107	92936621	Cushion
● 105-2	92906874	Card-V.D.E.			
● 105-3	92954770	OWNERS-MANUAL			
▲ 105-3	92954770	OWNERS-MANUAL			
■ 105-4	92954780	OWNERS-MANUAL			

Notes : ● : West German model only (AD), ▲ : Canadian model only (UQ),
 ■ : American model only (UC), Others : Common.

Packing Method View

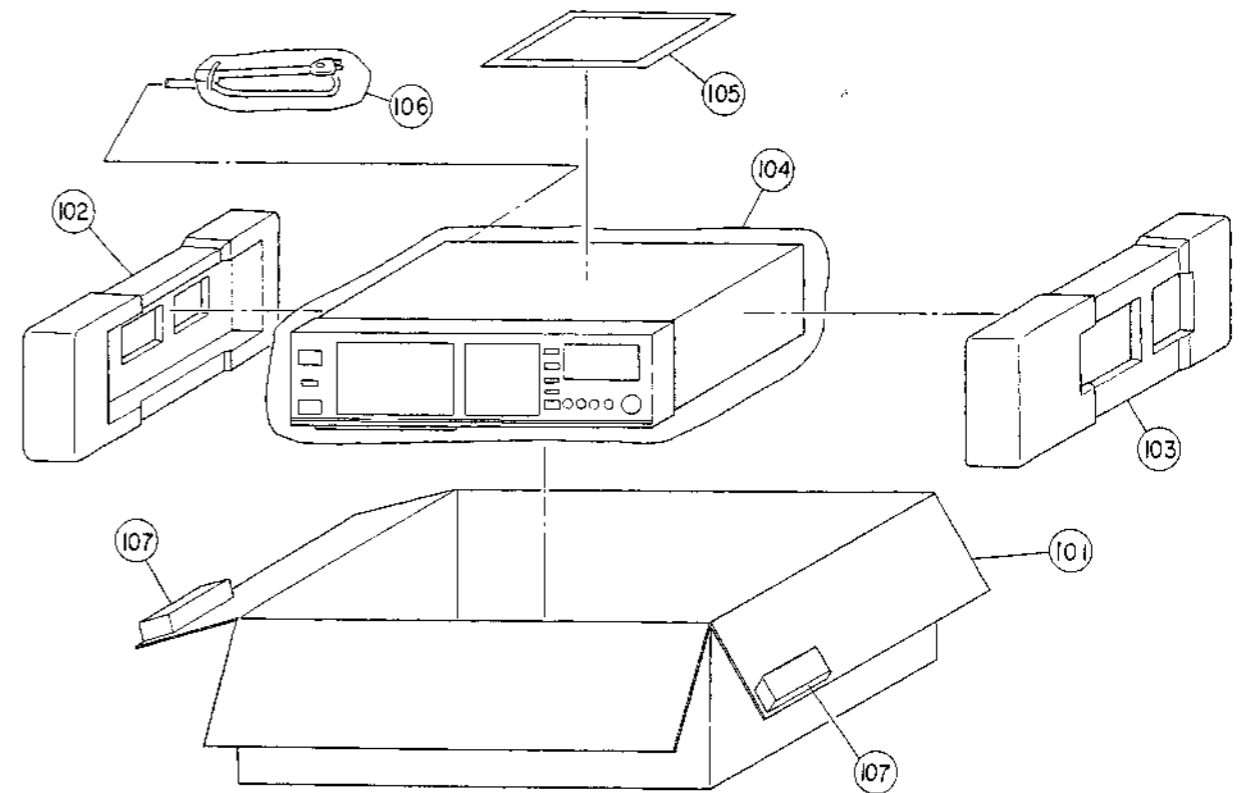

Parts Layout on P.C. Boards and Wiring Diagram

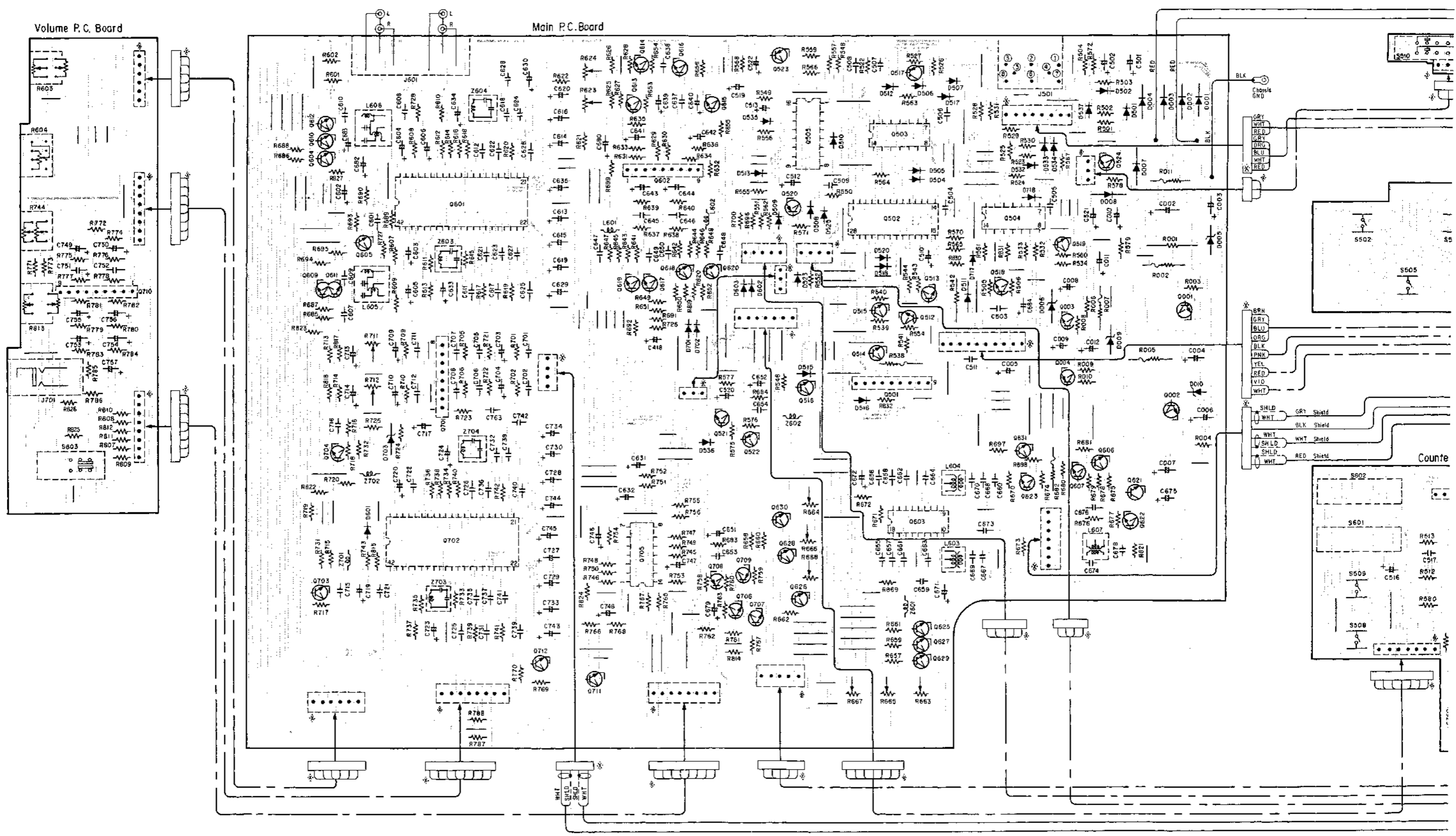

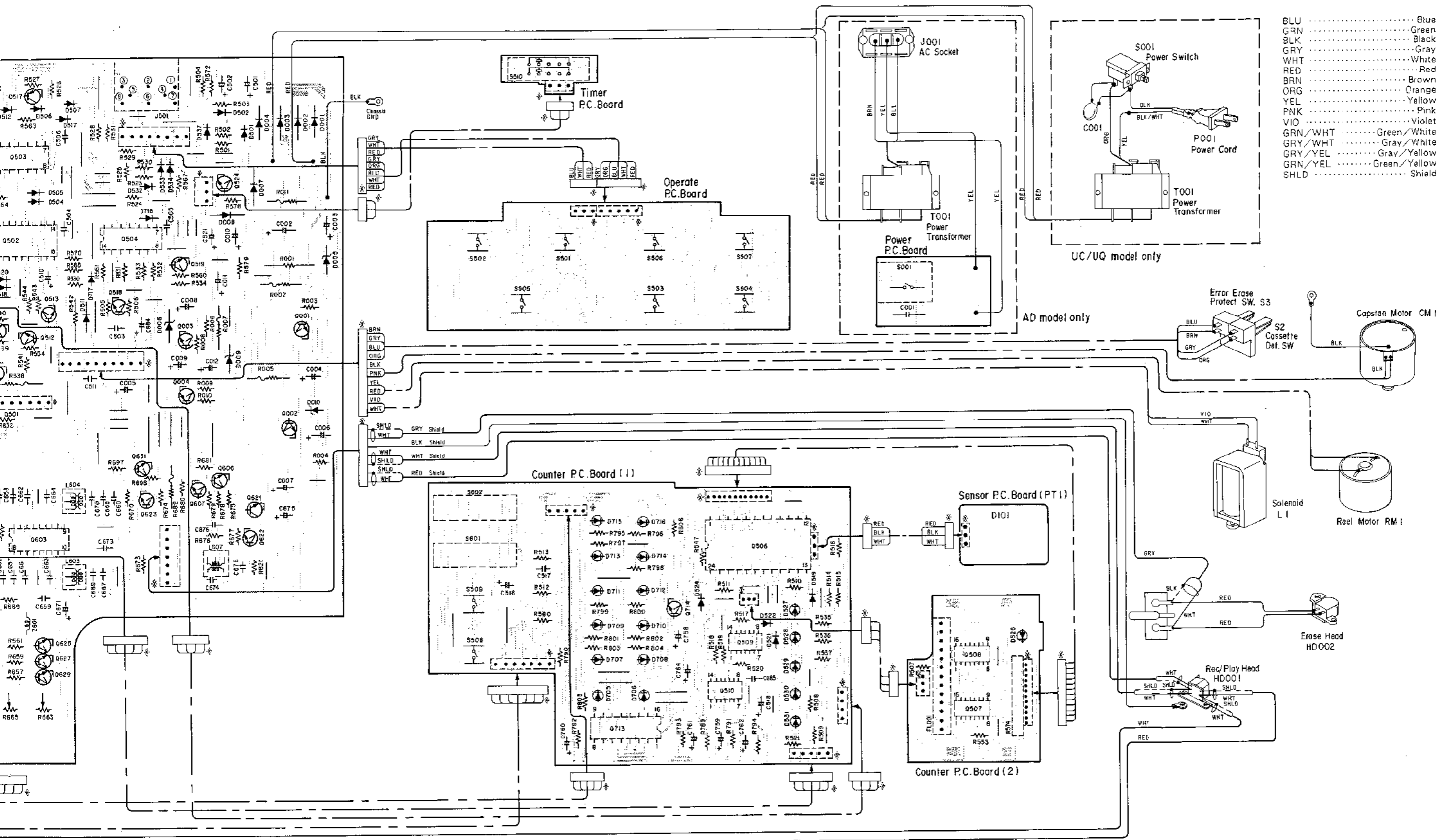

- BLU Blue
- GRN Green
- BLK Black
- GRY Gray
- WHT White
- RED Red
- BRN Brown
- ORG Orange
- YEL Yellow
- PNK Pink
- VIO Violet
- GRN/WHT Green/White
- GRY/WHT Gray/White
- GRY/YEL Gray/Yellow
- GRN/YEL Green/Yellow
- SHLD Shield

Schematic Diagram (1/2)

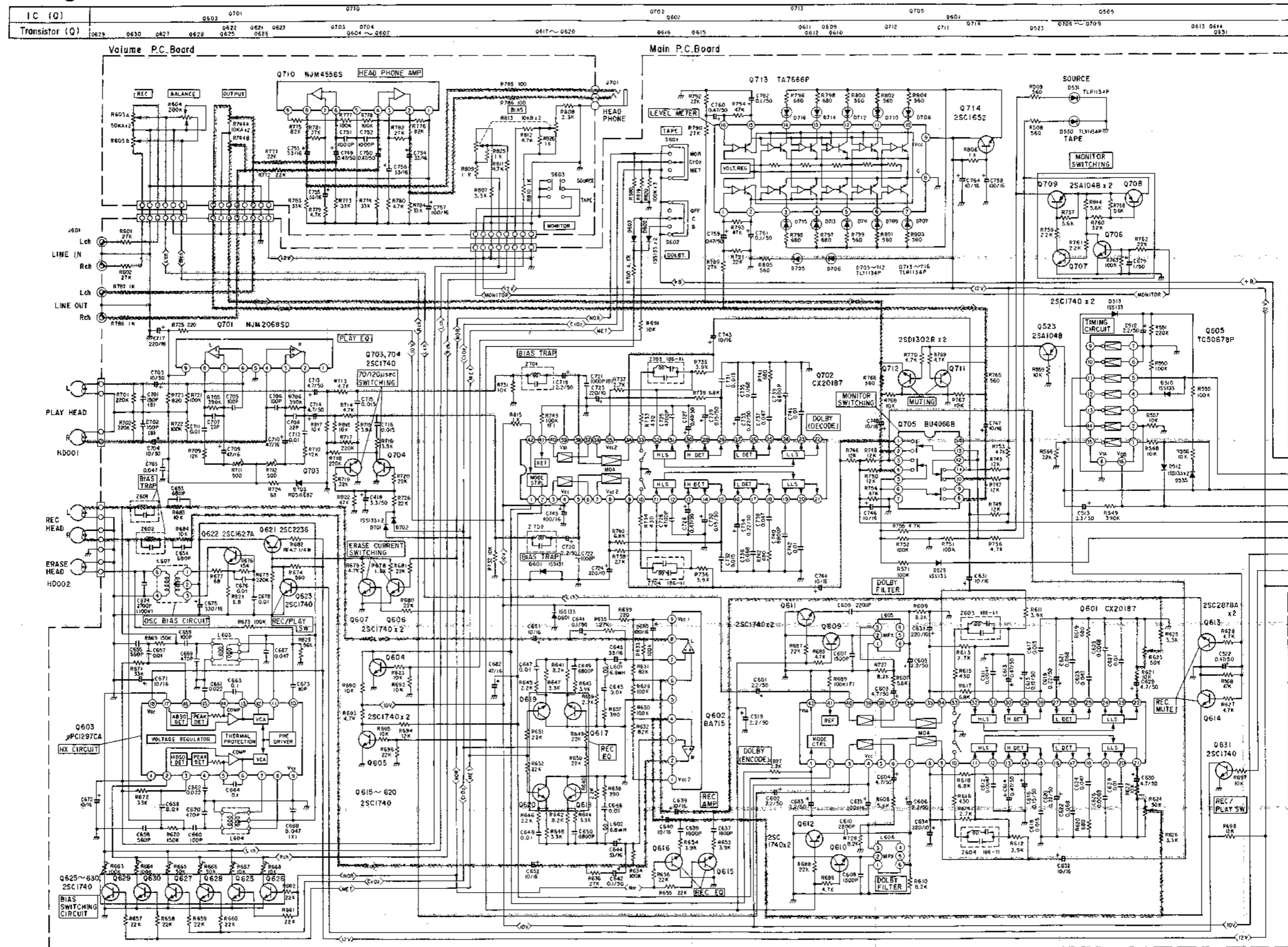

IC (Q)	Q603	Q701	Q710	Q713	Q714	Q715	Q716	Q717	Q718	Q719	Q720	Q721	Q722	Q723	Q724	Q725	Q726	Q727	Q728	Q729	Q730	Q731	Q732	Q733	Q734	Q735	Q736	Q737	Q738	Q739	Q740	Q741	Q742	Q743	Q744	Q745	Q746	Q747	Q748	Q749	Q750	Q751	Q752	Q753	Q754	Q755	Q756	Q757	Q758	Q759	Q760	Q761	Q762	Q763	Q764	Q765	Q766	Q767	Q768	Q769	Q770	Q771	Q772	Q773	Q774	Q775	Q776	Q777	Q778	Q779	Q780	Q781	Q782	Q783	Q784	Q785	Q786	Q787	Q788	Q789	Q790	Q791	Q792	Q793	Q794	Q795	Q796	Q797	Q798	Q799	Q800
--------	------	------	------	------	------	------	------	------	------	------	------	------	------	------	------	------	------	------	------	------	------	------	------	------	------	------	------	------	------	------	------	------	------	------	------	------	------	------	------	------	------	------	------	------	------	------	------	------	------	------	------	------	------	------	------	------	------	------	------	------	------	------	------	------	------	------	------	------	------	------	------	------	------	------	------	------	------	------	------	------	------	------	------	------	------	------	------	------	------	------	------

Transistor (Q)	Q629	Q630	Q627	Q628	Q625	Q626	Q623	Q624	Q625	Q626	Q627	Q628	Q629	Q630	Q631	Q632	Q633	Q634	Q635	Q636	Q637	Q638	Q639	Q640	Q641	Q642	Q643	Q644	Q645	Q646	Q647	Q648	Q649	Q650	Q651	Q652	Q653	Q654	Q655	Q656	Q657	Q658	Q659	Q660	Q661	Q662	Q663	Q664	Q665	Q666	Q667	Q668	Q669	Q670	Q671	Q672	Q673	Q674	Q675	Q676	Q677	Q678	Q679	Q680	Q681	Q682	Q683	Q684	Q685	Q686	Q687	Q688	Q689	Q690	Q691	Q692	Q693	Q694	Q695	Q696	Q697	Q698	Q699	Q700	Q701	Q702	Q703	Q704	Q705	Q706	Q707	Q708	Q709	Q710	Q711	Q712	Q713	Q714	Q715	Q716	Q717	Q718	Q719	Q720	Q721	Q722	Q723	Q724	Q725	Q726	Q727	Q728	Q729	Q730	Q731	Q732	Q733	Q734	Q735	Q736	Q737	Q738	Q739	Q740	Q741	Q742	Q743	Q744	Q745	Q746	Q747	Q748	Q749	Q750	Q751	Q752	Q753	Q754	Q755	Q756	Q757	Q758	Q759	Q760	Q761	Q762	Q763	Q764	Q765	Q766	Q767	Q768	Q769	Q770	Q771	Q772	Q773	Q774	Q775	Q776	Q777	Q778	Q779	Q780	Q781	Q782	Q783	Q784	Q785	Q786	Q787	Q788	Q789	Q790	Q791	Q792	Q793	Q794	Q795	Q796	Q797	Q798	Q799	Q800
----------------	------	------	------	------	------	------	------	------	------	------	------	------	------	------	------	------	------	------	------	------	------	------	------	------	------	------	------	------	------	------	------	------	------	------	------	------	------	------	------	------	------	------	------	------	------	------	------	------	------	------	------	------	------	------	------	------	------	------	------	------	------	------	------	------	------	------	------	------	------	------	------	------	------	------	------	------	------	------	------	------	------	------	------	------	------	------	------	------	------	------	------	------	------	------	------	------	------	------	------	------	------	------	------	------	------	------	------	------	------	------	------	------	------	------	------	------	------	------	------	------	------	------	------	------	------	------	------	------	------	------	------	------	------	------	------	------	------	------	------	------	------	------	------	------	------	------	------	------	------	------	------	------	------	------	------	------	------	------	------	------	------	------	------	------	------	------	------	------	------	------	------	------	------	------	------	------	------	------	------	------	------	------	------	------

Q602	1	10V
2	5.5V	
3	5.5V	
4	5.5V	
5	5.5V	
6	5.5V	
7	5.5V	
8	5.5V	
9	10V	

Q702	1	10.4V
2	5.5V	
3	5.5V	
4	5.5V	
5	5V	
6	5.5V	
7	5.5V	
8	5.5V	
9	5.5V	

Q718	1	10.4V
2	5.5V	
3	5.5V	
4	5.5V	
5	5V	
6	5.5V	
7	5.5V	
8	5.5V	
9	10.4V	

Q705	1	5.5V
2	5.5V	
3	5.5V	
4	5.5V	
5	5.5V	
6	5.5V	
7	5.5V	
8	5.5V	
9	5.5V	

Q604	1	REC MUTE
2	5.5V	
3	5.5V	
4	5.5V	
5	5.5V	
6	5.5V	
7	5.5V	
8	5.5V	
9	5.5V	

Q605	1	5.5V
2	5.5V	
3	5.5V	
4	5.5V	
5	5.5V	
6	5.5V	
7	5.5V	
8	5.5V	
9	5.5V	

Q606	1	5.5V
2	5.5V	
3	5.5V	
4	5.5V	
5	5.5V	
6	5.5V	
7	5.5V	
8	5.5V	
9	5.5V	

Q607	1	5.5V
2	5.5V	
3	5.5V	
4	5.5V	
5	5.5V	
6	5.5V	
7	5.5V	
8	5.5V	
9	5.5V	

Q608	1	5.5V
2	5.5V	
3	5.5V	
4	5.5V	
5	5.5V	
6	5.5V	
7	5.5V	
8	5.5V	
9	5.5V	

Q609	1	5.5V
2	5.5V	
3	5.5V	
4	5.5V	
5	5.5V	
6	5.5V	
7	5.5V	
8	5.5V	
9	5.5V	

Q610	1	5.5V
2	5.5V	
3	5.5V	
4	5.5V	
5	5.5V	
6	5.5V	
7	5.5V	
8	5.5V	
9	5.5V	

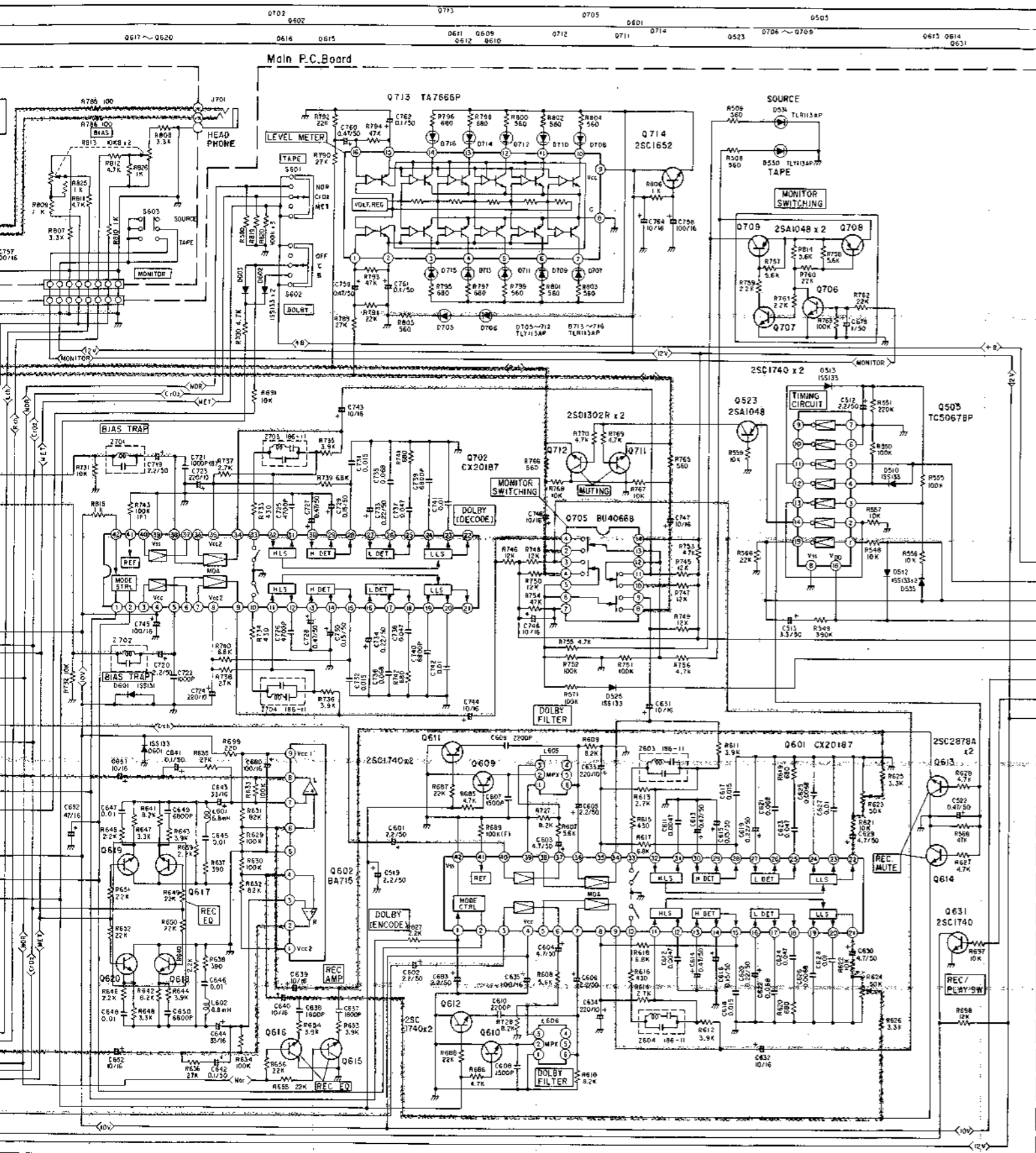

Q602	Q603	Q605
1 10V	1 4.4V	1 5.4V
2 5.5V	2 Bias fine cont	2 10V
3 5.5V	3 0.7- 5.5V	3 11V
4 5.5V	4 4.4V	4 11V
5 5.5V	5 4.4V	5 11V
6 5.5V	6 0V	6 11V
7 5.5V	7 0V	7 11V
8 5.5V	8 0V	8 11V
9 10V	9 0V	9 11V

Q701	Q702	Q703
1 4.4V	1 Other 10.4V	1 5.4V
2 5.5V	2 MR-C 0V	2 5.5V
3 5.5V	3 MR-0FF 10.3V	3 5.5V
4 5.5V	4 MR-C 0V	4 5.5V
5 0V	5 5.5V	5 5.5V
6 5.5V	6 10.4V	6 0.4V
7 5.5V	7 5.5V	7 0.4V
8 5.5V	8 5.5V	8 0.2V
9 5.5V	9 5.5V	9 0.1V
10 5.5V	10 5.5V	10 5.5V
11 5.5V	11 5.5V	11 5.5V
12 5.5V	12 5.5V	12 5.5V
13 5.5V	13 5.5V	13 5.5V
14 5.5V	14 5.5V	14 5.5V
15 5.5V	15 5.5V	15 5.5V
16 5.5V	16 5.5V	16 5.5V
17 5.5V	17 5.5V	17 5.5V
18 5.5V	18 5.5V	18 5.5V
19 5.5V	19 5.5V	19 5.5V
20 5.5V	20 5.5V	20 5.5V

Q604	Q606	Q607
MR-C 0V	Other 0V	Other 0V
Other 0V	Other 0V	Other 0V

Q608	Q609	Q610
Other 0V	Other 0V	Other 0V
Other 0V	Other 0V	Other 0V

Q611	Q612	Q613
Other 0V	Other 0V	Other 0V
Other 0V	Other 0V	Other 0V

Q614	Q615	Q616
Other 0V	Other 0V	Other 0V
Other 0V	Other 0V	Other 0V

Q617	Q618	Q619
Other 0V	Other 0V	Other 0V
Other 0V	Other 0V	Other 0V

Q620	Q621	Q622
Other 0V	Other 0V	Other 0V
Other 0V	Other 0V	Other 0V

Q623	Q624	Q625
Other 0V	Other 0V	Other 0V
Other 0V	Other 0V	Other 0V

Q626	Q627	Q628
Other 0V	Other 0V	Other 0V
Other 0V	Other 0V	Other 0V

Q629	Q630	Q631
Other 0V	Other 0V	Other 0V
Other 0V	Other 0V	Other 0V

Q632	Q633	Q634
Other 0V	Other 0V	Other 0V
Other 0V	Other 0V	Other 0V

Q635	Q636	Q637
Other 0V	Other 0V	Other 0V
Other 0V	Other 0V	Other 0V

Q638	Q639	Q640
Other 0V	Other 0V	Other 0V
Other 0V	Other 0V	Other 0V

Q641	Q642	Q643
Other 0V	Other 0V	Other 0V
Other 0V	Other 0V	Other 0V

Q644	Q645	Q646
Other 0V	Other 0V	Other 0V
Other 0V	Other 0V	Other 0V

Q647	Q648	Q649
Other 0V	Other 0V	Other 0V
Other 0V	Other 0V	Other 0V

Q650	Q651	Q652
Other 0V	Other 0V	Other 0V
Other 0V	Other 0V	Other 0V

Q653	Q654	Q655
Other 0V	Other 0V	Other 0V
Other 0V	Other 0V	Other 0V

Q656	Q657	Q658
Other 0V	Other 0V	Other 0V
Other 0V	Other 0V	Other 0V

Q659	Q660	Q661
Other 0V	Other 0V	Other 0V
Other 0V	Other 0V	Other 0V

Q662	Q663	Q664
Other 0V	Other 0V	Other 0V
Other 0V	Other 0V</	

Schematic Diagram (2/2)

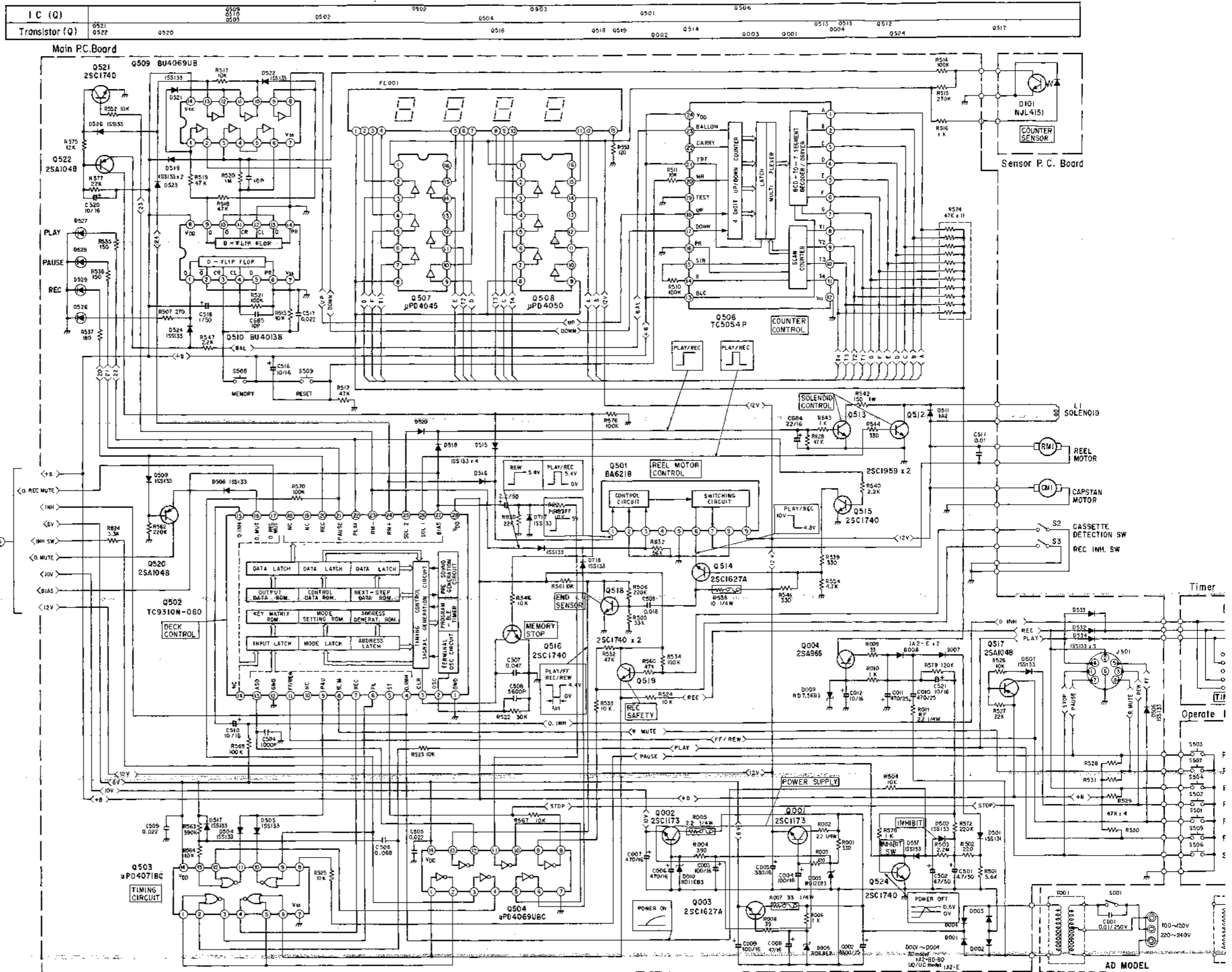

- NOTES:**
1. All resistance values are in ohms, K = 1,000
 2. All capacitance values are in microfarads, P = 1,000,000

K - 112

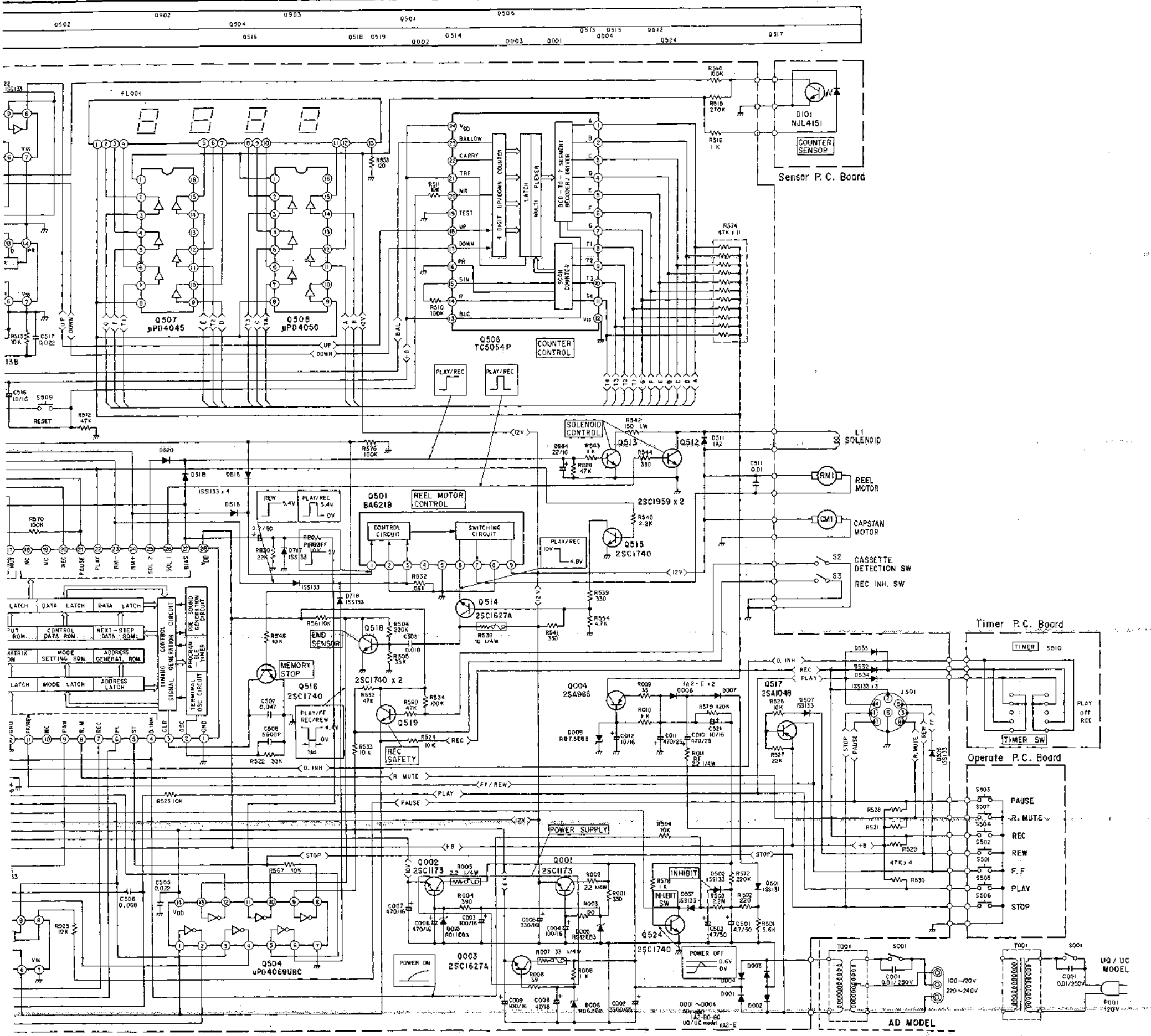

Q501

1	Play-Rec.FF	4.0V
2	FF	8.1V
3	Rev	5.4V
4	Other	0V
5	0V	0V
6	Play-Rec	4.0V
7	Rev	8.1V
8	Other	0.3V

Q1

E	C	B
10V	16.6V	12.8V

Q2

E	C	B
16.4V	16.7V	7.13.1V

Q3

E	C	B
0V	10.4V	6.7V

Q4

E	C	B
-6.9V	-7.5V	-7.4V

Q502

1	0V	
2	0V	
3	0V	
4	5.4V	
5	0V	
6	0V	
7	0V	
8	6V	
9	6V	
10	6V	
11	2.1V	
12	0V	
13	0V	
14	0V	
15	0V	
16	Play-Rec	5.5V
17	Rev	5.5V
18	Other	0V
19	Play-Rec	0V
20	Rev	5.5V
21	Other	0V
22	Play-Rec	5.2V
23	Rev	5.4V
24	Other	0V
25	Play-Rec.FF	5.5V
26	Other	0V
27	Play-Rec	5.5V
28	Rev	5.2V
29	Other	0V
30	Pause	5.2V
31	Other	0V
32	Rec	5.5V
33	Other	0V
34	Other	0V
35	Other	0V

Q512

E	C	B
0V	11.6V	0V
0V	6.9V	0V

Q513

E	C	B
0V	21.6V	0V
0V	0V	0.8V

Q514

E	C	B
10.4V	11.8V	10.8V
4.8V	10.7V	5.4V

Q515

E	C	B
0V	10.8V	0V
0V	0V	0.8V

Q503

1	0V	
2	6V	
3	6V	
4	6V	
5	6V	
6	0.5V	
7	0V	
8	0V	
9	Pause	5.2V
10	Other	0V
11	6V	
12	Pause	0V
13	Other	6V
14	6V	
15	5.8V	
16	6.3V	
17	FF-Rec	5.5V
18	Play-Rec	5.5V
19	Rev	0V
20	Rev	0V
21	Reset Push	0V
22	0V	0V
23	0V	0V
24	6V	0V
25	3.4V	0V
26	0V	0V
27	0V	0V
28	0V	0V
29	0V	0V
30	0V	0V

Q516

E	C	B
0V	0V	0V

Q517

E	C	B
0V	0V	0V

Q518

E	C	B
0V	4.4V	0.5V

Q519

E	C	B
0V	0V	0V
0V	0V	0V
0V	0V	0V

Q520

E	C	B
0V	0V	0V
0V	0V	0V
0V	0V	0V

Q504

1	0V	
2	0V	
3	Pause	5.2V
4	Other	0V
5	Other	0V
6	0V	
7	0V	
8	2V	
9	0V	
10	6V	
11	0V	
12	0V	
13	4.8V	
14	6V	
15	FF-Rec	5.5V
16	Play-Rec	5.5V
17	Rev	0V
18	Rev	0V
19	Reset Push	0V
20	0V	0V
21	0V	0V
22	0V	0V
23	0V	0V
24	6V	0V
25	3.4V	0V
26	0V	0V
27	0V	0V
28	0V	0V
29	0V	0V
30	0V	0V

Q521

E	C	B
0V	0V	0V
0V	0V	0.7V
0V	6.3V	0V

Q522

E	C	B
0V	0V	0V
0V	0V	2.1V
0V	0V	0V

Q523

E	C	B
5.7V	5.7V	5V
0V	0V	0V

Q524

Power On Mode	-0.5V
Power Off Mode	0.4V
Power On Mode	5V
Power Off Mode	0V

Q505

1	11.0
2	12V
3	0V
4	-6.5V
5	5.8V
6	0V
7	0V
8	5.4V
9	0V
10	0V
11	0V
12	0V
13	0V
14	0V
15	0V
16	0V
17	0V
18	0V
19	0V
20	0V
21	0V
22	0V
23	0V
24	0V
25	0V
26	0V
27	0V
28	0V
29	0V
30	0V

Q525

E	C	B
0V	0V	0V
0V	0V	0V
0V	0V	0V
0V	0V	0V

Q506

1	FF-Rec	5.5V
2	Play-Rec	5.5V
3	Rev	0V
4	Rev	0V
5	Other	0V
6	0V	0V
7	0V	0V
8	0V	0V
9	0V	0V
10	Rev	0V
11	Rev	0V
12	Other	0V
13	Rev	0V
14	0V	0V
15	0V	0V
16	0V	0V
17	0V	0V
18	0V	0V
19	0V	0V
20	0V	0V
21	0V	0V
22	0V	0V
23	0V	0V
24	0V	0V
25	0V	0V
26	0V	0V
27	0V	0V
28	0V	0V
29	0V	0V
30	0V	0V

Q526

1	Memory ON	3.5V
2	Memory OFF	0V
3	Memory ON	0V
4	Memory OFF	0V
5	Memory Push	6V
6	Other	0V
7	0V	0V
8	0V	0V
9	FF-Rec	5.5V
10	Play-Rec	5.5V
11	Rev	0V
12	Rev	0V
13	Other	0V
14	0V	0V
15	0V	0V
16	0V	0V
17	0V	0V
18	0V	0V
19	0V	0V
20	0V	0V
21	0V	0V
22	0V	0V
23	0V	0V
24	0V	0V
25	0V	0V
26	0V	0V
27	0V	0V
28	0V	0V
29	0V	0V
30	0V	0V

Q527

E	C	B
5V	5V	4.8V
5V	5V	4.5V
Source	4.1V	4.1V
Other	0V	0V

Q528

E	C	B
0V	0V	0V

Electrical Parts List

Capacitors : UF = microfarads, pF = picofarads

Abbreviations					Symbol No.	Part No.	Description		
RES. = Resistor CAP. = Capacitor C.F. = Carbon Film ELY. = Electrolytic M.F. = Metal Film CER. = Ceramic M.O. = Metal Oxide Film MYL. = Mylar M.P. = Metal Plate TAN. = Tantalum TR. = Transistor POLY. = Polystyrol TRANS. = Transformer PP. = Polypropylene CP. = Chip PLT. = Polyethylene					Symbol No.	Part No.	Description		
Volume P. C. Board									
IC/Switch/Jack									
Q710	92117815	IC. NJM4556S							
S603	92190238	Switch - Push							
J701	92198317	Jack, Headphone							
Capacitors									
C749	90418478	ELY., 0.47 μ F/50V							
C750	90418478	ELY., 0.47 μ F/50V							
C751	90343102	CER., 1000pF							
C752	90343102	CER., 1000pF							
C753	90415330	ELY., 33 μ F/16V							
C754	90415330	ELY., 33 μ F/16V							
C755	90415330	ELY., 33 μ F/16V							
C756	90415330	ELY., 33 μ F/16V							
C757	90415101	ELY., 100 μ F/16V							
Resistors (All resistors are Carbon 1/6W \pm 5% unless otherwise noted.)									
R603	92614204	Variable, 50k ohm (Rec-Level)							
R604	92618003	Variable, 200k ohm (Rec-Balance)							
R744	92611011	Variable, 10k ohm (Output)							
R771	90512223	22k ohm							
R772	90512223	22k ohm							
R773	90512333	33k ohm							
R774	90512333	33k ohm							
R775	90512823	82k ohm							
R776	90512823	82k ohm							
R777	90512104	100k ohm							
R778	90512104	100k ohm							
R779	90512472	4.7k ohm							
R780	90512472	4.7k ohm							
R781	90512273	27k ohm							
R782	90512273	27k ohm							
R783	90512333	33k ohm							
R784	90512333	33k ohm							
R785	90512101	100 ohm							
R786	90512101	100 ohm							
R807	90512332	3.3k ohm							
R808	90512332	3.3k ohm							
R809	90512102	1k ohm							
R810	90512102	1k ohm							
R811	90512472	4.7k ohm							
R812	90512472	4.7k ohm							
R813	92612016	Variable, 10k ohm (Bias Fine)							
R825	90512102	1k ohm							
R826	90512102	1k ohm							
Counter P. C. Board (1)									
IC's/Transistors									
Q506	80480540	IC. TC5054P							
Q509	92128049	IC. BU4069UBF							
Q510	92128048	IC. BU4013BF							
Q713	40356660	IC. TA7668P							
Q714	92128057	2SC1652-R							
Diodes/LED's									
D519	92119073	1SS133							
D521	92119073	1SS133							
D522	92119073	1SS133							
D524	92119073	1SS133							
D527	A8605695	LED, TLG113AP							
D528	38607985	LED, TLY113AP							
D529	A8600645	LED, TLR113AP							
D530	38607985	LED, TLY113AP							
D531	A8600645	LED, TLR113AP							
D705	38607985	LED, TLY113AP							
D706	38607985	LED, TLY113AP							
D707	38607985	LED, TLY113AP							
D708	38607985	LED, TLY113AP							
D709	38607985	LED, TLY113AP							
D710	38607985	LED, TLY113AP							
D711	38607985	LED, TLY113AP							
D712	38607985	LED, TLY113AP							
D713	A8600645	LED, TLR113AP							
D714	A8600645	LED, TLR113AP							
D715	A8600645	LED, TLR113AP							
D716	A8600645	LED, TLR113AP							

Symbol No.	Part No.	Description			Symbol No.	Part No.	Description		
Switches									
S508	92196492	Tact			R795	90512681	680 ohm		
S509	92196492	Tact			R796	90512681	680 ohm		
S601	92190237	Slide			R797	90512681	680 ohm		
S602	92190237	Slide			R798	90512681	680 ohm		
					R799	90512561	560 ohm		
Capacitors									
C516	90415100	ELY., 10 μ F/16V			R800	90512561	560 ohm		
C517	90351223	Axial CER., 0.022 μ F			R801	90512561	560 ohm		
C518	90418109	ELY., 1 μ F/50V			R802	90512561	560 ohm		
C685	90311100	CER., 10pF			R803	90512561	560 ohm		
C758	90415101	ELY., 100 μ F/16V			R804	90512561	560 ohm		
C759	90418108	ELY., 0.1 μ F/50V			Operate P. C. Board				
C760	90418108	ELY., 0.1 μ F/50V			Switches				
C761	90418479	ELY., 4.7 μ F/50V			S501	92196961	Tact. (F.F)		
C762	90418479	ELY., 4.7 μ F/50V			S502	92196961	Tact. (REW)		
C764	90415100	ELY., 10 μ F/16V			S503	92196961	Tact. (PAUSE)		
Resistors (All resistors are Carbon 1/6W \pm 5% unless otherwise noted.)					S504	92196961	Tact. (REC)		
R508	90512561	560 ohm			S505	92196961	Tact. (PLAY)		
R509	90512561	560 ohm			S506	92196961	Tact. (STOP)		
R510	90512104	100k ohm			S507	92196961	Tact. (RMUTE)		
R511	90512103	10k ohm			Counter P. C. Board (2)				
R512	90512473	47k ohm			IC's/LED/FL Tube/Resistors				
R513	90512103	10k ohm			Q507	92128054	IC, μ PD4050BG		
R514	90512104	100k ohm			Q508	92128054	IC, μ PD4050BG		
R515	90512274	270k ohm			D526	A8600645	LED, TLR113AP		
R516	90512102	1k ohm			FL001	92104677	FL Tube		
R517	90512103	10k ohm			R507	90512271	270 ohm		
R518	90512473	47k ohm			R553	90512121	120 ohm		
R519	90512473	47k ohm			R574	92134182	Network, 47k ohm \times 11		
R520	90512105	1M ohm			Power P. C. Board				
R521	90512104	100k ohm			Switch/Capacitor				
R535	90512151	150 ohm			S001	92196751	Switch (Power)		
R536	90512151	150 ohm			C001	92340228	0.01 μ F/250V		
R537	90512181	180 ohm							
R547	90512222	2.2k ohm							
R580	90512104	100k ohm							
R789	90512273	27k ohm							
R790	90512273	27k ohm							
R791	90512223	22k ohm							
R792	90512223	22k ohm							
R793	90512473	47k ohm							
R794	90512473	47k ohm							

Symbol No.	Part No.	Description			Symbol No.	Part No.	Description		
Main P. C. Board									
IC's/Transistors									
Q001	36771650	2SC1173-Y.X.JA			Q626	92117428	2SC1740-S		
Q002	36771650	2SC1173-Y.X.JA			Q627	92117428	2SC1740-S		
Q003	36314470	2SC1627A-Y			Q628	92117428	2SC1740-S		
Q004	36533247	2SA966-Y (C)			Q629	92117428	2SC1740-S		
Q501	92128052	IC, BA6218			Q630	92117428	2SC1740-S		
Q502	40413159	IC, TC9310N-060			Q631	92117428	2SC1740-S		
Q503	92117298	IC, UPD4071BC			Q701	92117845	IC, NJM2068SD		
Q504	92117467	IC, UPD4069UBC			Q702	92117814	IC, CX20187		
Q505	40480672	IC, TC5067BP			Q703	92117428	2SC1740-S		
Q512	36319300	2SC1959NEW-Y			Q704	92117428	2SC1740-S		
Q513	36319300	2SC1959NEW-Y			Q705	92128050	IC, BU4066B		
Q514	36314470	2SC1627A-Y			Q706	92117428	2SC1740-S		
Q515	92117428	2SC1740-S			Q707	92117428	2SC1740-S		
Q516	92117428	2SC1740-S			Q708	36534440	2SA1048GR		
Q517	36534440	2SA1048GR			Q709	36534440	2SA1048GR		
Q518	92117428	2SC1740-S			Q711	92117150	2SD1302-S		
Q519	92117428	2SC1740-S			Q712	92117150	2SD1302-S		
Q520	36534440	2SA1048GR			Diodes				
Q521	92117428	2SC1740-S			● D001	92119353	1A2-BD-80		
Q522	36534440	2SA1048GR			■ D001	92119310	1A2-E		
Q523	36534440	2SA1048GR			▲ D001	92119310	1A2-E		
Q524	92117428	2SC1740-S			● D002	92119353	1A2-BD-80		
Q601	92117814	IC, CX20187			■ D002	92119310	1A2-E		
Q602	92128051	IC, BA715			▲ D002	92119310	1A2-E		
Q603	92128053	IC, UPC1297CA			● D003	92119353	1A2-BD-80		
Q604	92117428	2SC1740-S			■ D003	92119310	1A2-E		
Q605	92117428	2SC1740-S			▲ D003	92119310	1A2-E		
Q606	92117428	2SC1740-S			● D004	92119353	1A2-BD-80		
Q607	92117428	2SC1740-S			■ D004	92119310	1A2-E		
Q609	92117428	2SC1740-S			▲ D004	92119310	1A2-E		
Q610	92117428	2SC1740-S			D005	92115538	Zener, RD12E-B3		
Q611	92117428	2SC1740-S			D006	92119066	Zener, RD6.8E-B2		
Q612	92117428	2SC1740-S			D007	92119310	1A2-E		
Q613	36342200	2SC2878-A			D008	92119310	1A2-E		
Q614	36342200	2SC2878-A			D009	92115922	Zener, RD7.5E-B3		
Q615	92117428	2SC1740-S			D010	92115970	Zener, RD11E-B3		
Q616	92117428	2SC1740-S			D501	92119223	1SS131		
Q617	92117428	2SC1740-S			D502	92119073	1SS133		
Q618	92117428	2SC1740-S			D504	92119073	1SS133		
Q619	92117428	2SC1740-S			D505	92119073	1SS133		
Q620	92117428	2SC1740-S			D506	92119073	1SS133		
Q621	36325549	2SC2236-Y (C)			D507	92119073	1SS133		
Q622	36314470	2SC1627A-Y			D508	92119073	1SS133		
Q623	92117428	2SC1740-S			D509	92119073	1SS133		
Q625	92117428	2SC1740-S			D510	92119073	1SS133		
					D511	92119310	1A2-E		
					D512	92119073	1SS133		
					D513	92119073	1SS133		

Notes : ● : West German model only (AD), ▲ : Canadian model only (UQ),
 ■ : American model only (UC), Others : Common.

Symbol No.	Part No.	Description			Symbol No.	Part No.	Description		
D515	92119073	1SS133			Capacitors				
D516	92119073	1SS133			C002	90416332	ELY., 3300 μ F/25V		
D517	92119073	1SS133			C003	90415101	ELY., 100 μ F/16V		
D518	92119073	1SS133			C004	90415101	ELY., 100 μ F/16V		
D520	92119073	1SS133			C005	90415331	ELY., 330 μ F/16V		
D523	92119073	1SS133			C006	90415471	ELY., 470 μ F/16V		
D525	92119073	1SS133			C007	90415471	ELY., 470 μ F/16V		
D532	92119073	1SS133			C008	90415470	ELY., 47 μ F/16V		
D533	92119073	1SS133			C009	90415101	ELY., 100 μ F/16V		
D534	92119073	1SS133			C010	90416471	ELY., 470 μ F/25V		
D535	92119073	1SS133			C011	90416471	ELY., 470 μ F/25V		
D536	92119073	1SS133			C012	90415100	ELY., 10 μ F/16V		
D537	92119073	1SS133			C418	90418339	ELY., 3.3 μ F/50V		
D601	92119073	1SS133			C501	90418479	ELY., 4.7 μ F/50V		
D602	92119073	1SS133			C502	90418479	ELY., 4.7 μ F/50V		
D603	92119073	1SS133			C503	90318183	CER., 0.018 μ F		
D701	92119073	1SS133			C504	90343102	CER., 0.001 μ F		
D702	92119073	1SS133			C505	90351223	Axial CER., 0.022 μ F		
D703	92115937	Zener, RD5.6E-B2			C506	90341683	CER., 0.068 μ F		
D717	92119073	1SS133			C507	90318473	CER., 0.047 μ F		
D718	92119073	1SS133			C508	90371562	Polyester Film, 5600pF		
☆	92119073	1SS133			C509	90351223	Axial CER., 0.022 μ F		
Coils					C510	90415100	ELY., 10 μ F/16V		
L601	92232277	Choke, 6.8mH			C511	90353103	Axial CER., 0.01 μ F		
L602	92232277	Choke, 6.8mH			C512	90418229	ELY., 2.2 μ F/50V		
L603	92215149	HX PRO			C513	90418339	ELY., 3.3 μ F/50V		
L604	92215149	HX PRO			C519	90418229	ELY., 2.2 μ F/50V		
L605	92135094	Filter, MPX			C520	90415100	ELY., 10 μ F/16V		
L606	92135094	Filter, MPX			C521	90415100	ELY., 10 μ F/16V		
L607	92215148	OSC			C522	90418478	ELY., 0.47 μ F/50V		
Switch/Jacks					C601	90418229	ELY., 2.2 μ F/50V		
S510	92190237	Switch-Slide			C602	90418229	ELY., 2.2 μ F/50V		
J501	92169094	Jack-Cont			C603	90418479	ELY., 4.7 μ F/50V		
J601	92198282	Jack, US 4P			C604	90418479	ELY., 4.7 μ F/50V		
Filters					C605	90418229	ELY., 2.2 μ F/50V		
Z601	92135092	Bias			C606	90418229	ELY., 2.2 μ F/50V		
Z602	92135092	Bias			C607	90371152	Polyester Film, 1500pF		
Z603	92135065	Coil, Skewing			C608	90371152	Polyester Film, 1500pF		
Z604	92135065	Coil, Skewing			C609	90371222	Polyester Film, 2200pF		
Z701	92135093	Bias			C610	90371222	Polyester Film, 2200pF		
Z702	92135093	Bias			C611	90371472	Polyester Film, 4700pF		
Z703	92135065	Coil, Skewing			C612	90371472	Polyester Film, 4700pF		
Z704	92135065	Coil, Skewing			C613	90418478	ELY., 0.47 μ F/50V		
					C614	90418478	ELY., 0.47 μ F/50V		
					C615	92488158	ELY., 0.15 μ F/50V		
					C616	92488158	ELY., 0.15 μ F/50V		

NOTE: ☆: This part is added to be mounted on the bottom side of P. C. Boards.

Symbol No.	Part No.	Description			Symbol No.	Part No.	Description		
C617	90371153	Polyester Film, 0.015 μ F			C653	90343681	CER., 680pF		
C618	90371153	Polyester Film, 0.015 μ F			C654	90343681	CER., 680pF		
C619	90418228	ELY., 0.22 μ F/50V			C655	90343561	CER., 560pF		
C620	90418228	ELY., 0.22 μ F/50V			C656	90343561	CER., 560pF		
C621	90371683	Polyester Film, 0.068 μ F			C657	90353103	Axial CER., 0.01 μ F		
C622	90371683	Polyester Film, 0.068 μ F			C658	90353103	Axial CER., 0.01 μ F		
C623	90371473	Polyester Film, 0.047 μ F			C659	90343101	CER., 100pF		
C624	90371473	Polyester Film, 0.047 μ F			C660	90343101	CER., 100pF		
C625	90371682	Polyester Film, 6800pF			C661	90351223	Axial CER., 0.022 μ F		
C626	90371682	Polyester Film, 6800pF			C662	90351223	Axial CER., 0.022 μ F		
C627	90371103	Polyester Film, 0.01 μ F			C663	90318104	CER., 0.1 μ F		
C628	90371103	Polyester Film, 0.01 μ F			C664	90318104	CER., 0.1 μ F		
C629	90418479	ELY., 4.7 μ F/50V			C667	90318473	CER., 0.047 μ F		
C630	90418479	ELY., 4.7 μ F/50V			C668	90318473	CER., 0.047 μ F		
C631	90415100	ELY., 10 μ F/16V			C669	90343471	CER., 470pF		
C632	90415100	ELY., 10 μ F/16V			C670	90343471	CER., 470pF		
C633	90414221	ELY., 220 μ F/10V			C671	90415100	ELY., 10 μ F/16V		
C634	90414221	ELY., 220 μ F/10V			C672	90415100	ELY., 10 μ F/16V		
C635	90415101	ELY., 100 μ F/16V			C673	90311100	CER., 10pF		
C637	90371182	Polyester Film, 1800pF			C674	92321224	PP., 2700pF/100V		
C638	90371182	Polyester Film, 1800pF			C675	90415331	ELY., 330 μ F/16V		
C639	90415100	ELY., 10 μ F/16V			C676	90371103	Polyester Film, 0.01 μ F		
C640	90415100	ELY., 10 μ F/16V			C678	90371103	Polyester Film, 0.01 μ F		
C641	90418108	ELY., 0.1 μ F/50V			C679	90418109	ELY., 1 μ F/50V		
C642	90418108	ELY., 0.1 μ F/50V			C680	90415101	ELY., 100 μ F/16V		
C643	90415330	ELY., 33 μ F/16V			C682	90415470	ELY., 47 μ F/16V		
C644	90415330	ELY., 33 μ F/16V			C683	90418229	ELY., 2.2 μ F/50V		
C645	90371103	Polyester Film, 0.01 μ F			C684	90415220	ELY., 22 μ F/16V		
C646	90371103	Polyester Film, 0.01 μ F			C701	90343151	CER., 150pF		
C647	90371103	Polyester Film, 0.01 μ F			C702	90343151	CER., 150pF		
C648	90371103	Polyester Film, 0.01 μ F			C703	92440325	ELY., 10 μ F/16V		
C649	90371682	Polyester Film, 6800pF			C704	92440325	ELY., 10 μ F/16V		
C650	90371682	Polyester Film, 6800pF			C705	90343101	CER., 100pF		
C651	90415100	ELY., 10 μ F/16V			C706	90343101	CER., 100pF		
C652	90415100	ELY., 10 μ F/16V			C707	90311220	CER., 22pF		
					C708	90311220	CER., 22pF		
					C709	90415470	ELY., 47 μ F/16V		
					C710	90415470	ELY., 47 μ F/16V		
					C711	90371103	Polyester Film, 0.01 μ F		
					C712	90371103	Polyester Film, 0.01 μ F		
					C713	90418479	ELY., 4.7 μ F/50V		
					C714	90418479	ELY., 4.7 μ F/50V		
					C715	90371153	Polyester Film, 0.015 μ F		
					C716	90371153	Polyester Film, 0.015 μ F		
					C717	90415221	ELY., 220 μ F/16V		

Symbol No.	Part No.	Description	Symbol No.	Part No.	Description
C719	90418229	ELY., 2.2 μ F/50V	Resistors (All resistors are Carbon 1/6W \pm 5% unless otherwise noted.)		
C720	90418229	ELY., 2.2 μ F/50V	R001	90516331	330 ohm 1/2W
C721	90343102	CER., 1000pF	R002	90531229	Carbon Fuse, 2.2 ohm 1/4W
C722	90343102	CER., 1000pF	R003	90512121	120 ohm
C723	90414221	ELY., 220 μ F/10V	R004	90512391	390 ohm
C724	90414221	ELY., 220 μ F/10V	R005	90531229	Carbon Fuse, 2.2 ohm 1/4W
C725	90371472	Polyester Film, 4700pF	R006	90512102	1k ohm
C726	90371472	Polyester Film, 4700pF	R007	90531330	Carbon Fuse, 33 ohm 1/4W
C727	90418478	ELY., 0.47 μ F/50V	R008	90512390	39 ohm
C728	90418478	ELY., 0.47 μ F/50V	R009	90512330	33 ohm
C729	92488158	ELY., 0.15 μ F/50V	R010	90512102	1k ohm
C730	92488158	ELY., 0.15 μ F/50V	R011	90531229	Carbon Fuse, 2.2 ohm 1/4W
C731	90371153	Polyester Film, 0.015 μ F	R501	90512562	5.6k ohm
C732	90371153	Polyester Film, 0.015 μ F	R502	90512221	220 ohm
C733	90418228	ELY., 0.22 μ F/50V	R503	90512225	2.2M ohm
C734	90418228	ELY., 0.22 μ F/50V	R504	90512103	10k ohm
C735	90371683	Polyester Film, 0.068 μ F	R505	90512333	33k ohm
C736	90371683	Polyester Film, 0.068 μ F	R506	90512224	220k ohm
C737	90371473	Polyester Film, 0.047 μ F	R522	92550497	30k ohm 1/4W (\pm 2%)
C738	90371473	Polyester Film, 0.047 μ F	R523	90512103	10k ohm
C739	90371682	Polyester Film, 6800pF	R524	90512103	10k ohm
C740	90371682	Polyester Film, 6800pF	R525	90512103	10k ohm
C741	90371103	Polyester Film, 0.01 μ F	R526	90512103	10k ohm
C742	90371103	Polyester Film, 0.01 μ F	R527	90512223	22k ohm
C743	90415100	ELY., 10 μ F/16V	R528	90512473	47k ohm
C744	90415100	ELY., 10 μ F/16V	R529	90512473	47k ohm
C745	90415101	ELY., 100 μ F/16V	R530	90512473	47k ohm
C746	90415100	ELY., 10 μ F/16V	R531	90512473	47k ohm
C747	90415100	ELY., 10 μ F/16V	R532	90512473	47k ohm
C748	90415100	ELY., 10 μ F/16V	R533	90512103	10k ohm
☆ C763	90318473	CER., 0.047 μ F	R534	90512104	100k ohm
	90418229	ELY., 2.2 μ F/50V	R538	90531100	Carbon Fuse, 10 ohm 1/4W
			R539	90512331	330 ohm
			R540	90512222	2.2k ohm
			R541	90512331	330 ohm
			R542	92571151	150 ohm 1W
			R543	90512102	1k ohm
			R544	90512331	330 ohm
			R546	90512103	10k ohm
			R548	90512103	10k ohm
			R549	90512394	390k ohm
			R550	90512104	100k ohm
			R551	90512224	220k ohm
			R552	90512103	10k ohm
			R554	90512472	4.7k ohm
			R555	90512104	100k ohm

NOTE: ☆: This part is added to be mounted on the bottom side of P. C. Boards.

Symbol No.	Part No.	Description			Symbol No.	Part No.	Description		
R556	90512103	10k ohm			R635	90512273	27k ohm		
R557	90512103	10k ohm			R636	90512273	27k ohm		
R559	90512103	10k ohm			R637	90512391	390 ohm		
R560	90512473	47k ohm			R638	90512391	390 ohm		
R561	90512103	10k ohm			R639	90512222	2.2k ohm		
R562	90512224	220k ohm			R640	90512222	2.2k ohm		
R563	90512394	390k ohm			R641	90512822	8.2k ohm		
R564	90512103	10k ohm			R642	90512822	8.2k ohm		
R565	90512104	100k ohm			R643	90512392	3.9k ohm		
R566	90512223	22k ohm			R644	90512392	3.9k ohm		
R567	90512103	10k ohm			R645	90512222	2.2k ohm		
R568	90512473	47k ohm			R646	90512222	2.2k ohm		
R570	90512104	100k ohm			R647	90512332	3.3k ohm		
R571	90512104	100k ohm			R648	90512332	3.3k ohm		
R572	90512224	220k ohm			R649	90512223	22k ohm		
R575	90512123	12k ohm			R650	90512223	22k ohm		
R576	90512104	100k ohm			R651	90512223	22k ohm		
R577	90512223	22k ohm			R652	90512223	22k ohm		
R578	90512102	1k ohm			R653	90512393	39k ohm		
R579	90512124	120k ohm			R654	90512393	39k ohm		
R601	90512273	27k ohm			R655	90512223	22k ohm		
R602	90512273	27k ohm			R656	90512223	22k ohm		
R607	90512562	5.6k ohm			R657	90512223	22k ohm		
R608	90512562	5.6k ohm			R658	90512223	22k ohm		
R609	90512822	8.2k ohm			R659	90512223	22k ohm		
R610	90512822	8.2k ohm			R660	90512223	22k ohm		
R611	90512392	3.9k ohm			R661	90512223	22k ohm		
R612	90512392	3.9k ohm			R662	90512223	22k ohm		
R613	90512272	2.7k ohm			R663	92658947	Semi-Variable, 100k ohm		
R614	90512272	2.7k ohm			R664	92658947	Semi-Variable, 100k ohm		
R615	90512431	430 ohm			R665	92658946	Semi-Variable, 50k ohm		
R616	90512431	430 ohm			R666	92658946	Semi-Variable, 50k ohm		
R617	90512682	6.8k ohm			R667	92658944	Semi-Variable, 10k ohm		
R618	90512682	6.8k ohm			R668	92658944	Semi-Variable, 10k ohm		
R619	90512681	680 ohm			R669	90512154	150k ohm		
R620	90512681	680 ohm			R670	90512154	150k ohm		
R621	90512103	10k ohm			R671	90512333	33k ohm		
R622	90512103	10k ohm			R672	90512333	33k ohm		
R623	92658946	Semi-Variable, 50k ohm			R673	90512104	100k ohm		
R624	92658946	Semi-Variable, 50k ohm			R674	90512561	560 ohm		
R625	90512332	3.3k ohm			R675	90512224	220k ohm		
R626	90512332	3.3k ohm			R676	90512153	15k ohm		
R627	90512472	4.7k ohm			R677	90512680	68 ohm		
R628	90512472	4.7k ohm			R678	90512182	1.8k ohm		
R629	90512104	100k ohm			R679	90512472	4.7k ohm		
R630	90512104	100k ohm							
R631	90512823	82k ohm							
R632	90512823	82k ohm							
R633	90512104	100k ohm							
R634	90512104	100k ohm							

Symbol No.	Part No.	Description		Symbol No.	Part No.	Description		
R680	90512223	22k ohm		R736	90512392	3.9k ohm		
R681	90512223	22k ohm		R737	90512272	2.7k ohm		
R682	92500468	Carbon Fuse, 4.7 ohm 1/4W		R738	90512272	2.7k ohm		
R683	90512103	10k ohm		R739	90512682	6.8k ohm		
R684	90512103	10k ohm		R740	90512682	6.8k ohm		
R685	90512472	4.7k ohm		R741	90512681	680 ohm		
R686	90512472	4.7k ohm		R742	90512681	680 ohm		
R687	90512223	22k ohm		R743	92570777	100k ohm 1/4W		
R688	90512223	22k ohm		R745	90512123	12k ohm		
R689	92570777	100k ohm 1/4W		R746	90512123	12k ohm		
R690	90512103	10k ohm		R747	90512123	12k ohm		
R691	90512103	10k ohm		R748	90512123	12k ohm		
R692	90512103	10k ohm		R749	90512123	12k ohm		
R693	90512472	4.7k ohm		R750	90512123	12k ohm		
R694	90512123	12k ohm		R751	90512104	100k ohm		
R695	90512103	10k ohm		R752	90512104	100k ohm		
R696	90512223	22k ohm		R753	90512473	47k ohm		
R697	90512103	10k ohm		R754	90512473	47k ohm		
R698	90512123	12k ohm		R755	90512472	4.7k ohm		
R699	90512221	220 ohm		R756	90512472	4.7k ohm		
R700	90512472	4.7k ohm		R757	90512562	5.6k ohm		
R701	90512224	220k ohm		R758	90512562	5.6k ohm		
R702	90512224	220k ohm		R759	90512223	22k ohm		
R705	90512394	390k ohm		R760	90512223	22k ohm		
R706	90512394	390k ohm		R761	90512223	22k ohm		
R709	90512123	12k ohm		R762	90512223	22k ohm		
R710	90512123	12k ohm		R763	90512104	100k ohm		
R711	92658940	Semi-Variable, 500 ohm		R765	90512561	560 ohm		
R712	92658940	Semi-Variable, 500 ohm		R766	90512561	560 ohm		
R713	90512472	4.7k ohm		R767	90512103	10k ohm		
R714	90512472	4.7k ohm		R768	90512103	10k ohm		
R715	90512392	3.9k ohm		R769	90512472	4.7k ohm		
R716	90512392	3.9k ohm		R770	90512472	4.7k ohm		
R717	90512224	220k ohm		R787	90512102	1k ohm		
R718	90512224	220k ohm		R788	90512102	1k ohm		
R719	90512223	22k ohm		R814	90512562	5.6k ohm		
R720	90512223	22k ohm		R815	90512102	1k ohm		
R721	90512104	100k ohm		R817	90512103	10k ohm		
R722	90512104	100k ohm		R818	90512103	10k ohm		
R723	90512821	820 ohm		R819	90512104	100k ohm		
R724	90512680	68 ohm		R820	90512104	100k ohm		
R725	90512221	220 ohm		R821	90512689	6.8 ohm		
R726	90512223	22k ohm		R822	90512473	47k ohm		
R727	90512822	8.2k ohm		R823	90512103	10k ohm		
R728	90512822	8.2k ohm		R824	90512332	3.3k ohm		
R731	90512103	10k ohm		R827	90512222	2.2K ohm		
R732	90512103	10k ohm		R829	90512563	56k ohm		
R733	90512431	430 ohm		R830	90512223	22k ohm		
R734	90512431	430 ohm		R831	90512103	10k ohm		
R735	90512392	3.9k ohm		R832	90512563	56k ohm		

Symbol No.	Part No.	Description			Symbol No.	Part No.	Description		
Miscellaneous									
● T001	92224749	Trans-PT							
■ T001	92224748	Trans-PT							
▲ T001	92224748	Trans-PT							
● J001	92169225	Socket-AC-03P							
■ P001	92176756	Cord, Power							
▲ P001	92176756	Cord, Power							
HD001	22217528	Head, Record/ Playback							
HD002	22218255	Head, Evase							
RM1	25791358	Reel Motor Assy.							
CM1	25791796	Capstan Motor Assy.							
PT1	26112144	Sensor P. C. Board Assy.							
L1	22147248	Solenoid							

Notes : ● : West German model only (AD), ▲ : Canadian model only (UQ),
 ■ : American model only (UC), Others : Common.

Cabinet Assembly Parts List

NOTE: The parts without part numbers are not supplied.

Symbol No.	Index	Part No.	Description	Symbol No.	Index	Part No.	Description
1	5-F	95812610	Panel - Front	35		92707040	Screw, BID Hd.
2	2-H	95829767	Sub - Panel - Assy.	36		92707911	Screw, BID Hd. Tapping
4	4-B	92882651	Top - Cover				3d x 8mm (Black)
● 5	1-D	90826852	Plate - Jack	37		92707942	Screw, BID Hd. Tapping
■ 6	5-C	90826853	Plate - Jack				3d x 8mm (Black)
▲ 6	5-C	90826853	Plate - Jack	38	2-F	92702202	Screw, BID Hd. Tapping
7	5-G	95812653	Cassette - Holder - Assy.				3d x 8mm (Red)
8	5-G	95812613	Cover - Cassette	39	4-D	92708276	Screw, FLT Hd. Tapping
9	1-G	92755905	Bracket - Volume Stay				3d x 8mm (Black)
10	1-G	95848644	Stay				
11	5-E	92755906	Mount - Power	40	4-E	92708047	Screw, BID Hd. Tapping
12	3-F	92755904	Mount - Eject				4d x 8mm
13	4-F	95848645	Stay - C	41		92707842	Screw, BID Hd. Tapping
14	3-F	95864350	Mount - Cassette - Holder - L				3d x 8mm
15	2-F	95864272	Mount - Cassette - Holder - R	42	1-C	92707826	Screw, BID Hd. Tapping
16	3-G	92776814	Eject - Spring				3d x 10mm
17	3-F	95826946	Eject - Knob	43	5-F	92708624	Screw, FLT Hd. 3d x 6mm
18	2-G	95826944	Operation - Knob - Type B	44	3-C	92707445	Screw, BID Hd. 3d x 6mm
19	3-G	95826943	Operation - Knob - Type A	45		92708208	Screw, PAN Hd. with Washer
20	2-G	95826938	Push - Knob				2.6d x 10mm
21	1-F	95826945	Push - Knob	46	3-F	92708827	Screw, PAN Hd. with Washer
22		95826947	Slide - Knob				2.6d x 8mm
23	4-H	95826941	Volume - Knob	47	3-E	92707910	Screw, BID Hd. Tapping
24	4-H	90872225	Bias - Volume - Knob				3d x 6mm
25	5-G	95826942	Power - Knob	48	3-F	92707979	Screw, BID Hd. Tapping
26	3-F	95883246	Damper - New				2.6d x 8mm
27	2-E	90842679	Foot	51	2-C	92747678	Shield - Plate
28		92755908	P.C.B. - Support	54	4-D	92708539	Screw, BID Hd. 3d x 6mm
■ 30	5-B	95844322	Cord - Bush	55	2-F	92755907	F.L.D. - Holder
▲ 30	5-B	95844322	Cord - Bush	56	3-E	96212300	Mecha - Assy.
● 31	4-C	92184238	Cover - AC - Inlet	57	2-C	92198282	Jack - US - 4P
■ 32	4-E	92758261	Cover - Sw.	58	2-C	92169094	Jack - D.I.N. - 8P
▲ 32	4-E	92758261	Cover - Sw.				
33	2-C	90798758	Special - Rivet				
34	5-G	95779272	Spring - C - Hold				

Notes: ● : West German model only (AD), ▲ : Canadian model only (UQ), ■ : American model only (UC), Others : Common.

Exploded View (Cabinet)

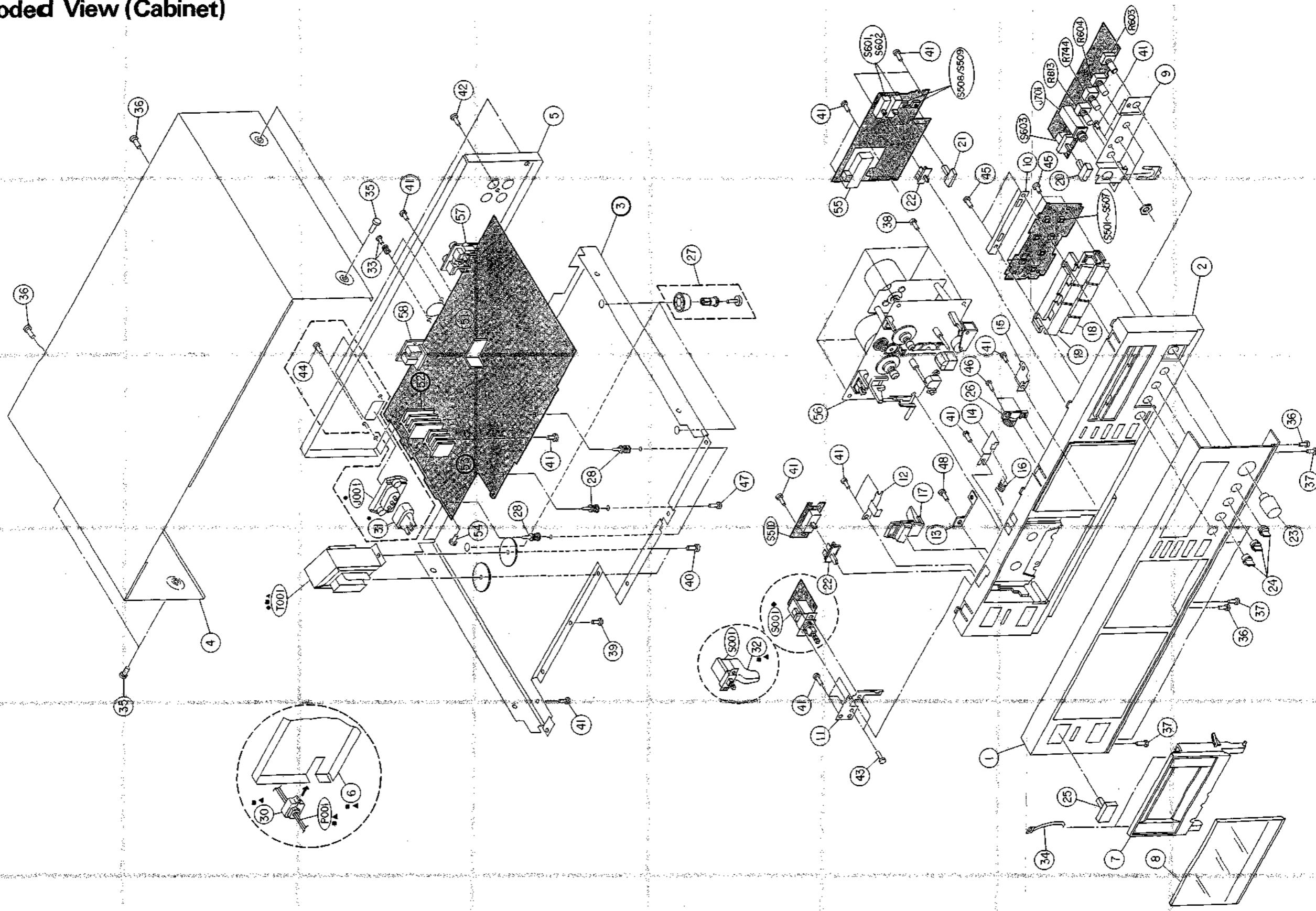

Notes : ● : West German model only (AD), ▲ : Canadian model only (UQ), ■ : American model only (UC). Others : Common.

Cassette Deck Assembly Parts List

Symbol No.	Index	Part No.	Description	Symbol No.	Index	Part No.	Description
203	2-C	25779142	Spring, Holder	244	4-F	25782415	Lock Lever, Play
207	2-B	22708568	Retaining Ring, 2mmd	245	4-F	25782422	Lever, Play
208		22707350	Screw, BID Hd. 2.6d x 5mmi	246	4-E	25762404	Pad, Erase Head
209		22707361	Screw, PAN Hd. with Washer 2.6d x 8mmi	247	4-E	25791301	Shaft Assy., Head Pad
210	2-G	22707429	Screw, Special, 2.6d x 4.9mmi	248	5-A	25777040	Spring, Erase Head
212	3-G	25755480	Belt, Drive	249	4-C	25776516	Spring, Lock Slider
213		25761238	Cushion, Motor	250	4-B	25776317	Spring, Head Mtg.
214	2-B	25773526	Spring, Pressure Roller	251	2-B	25712408	Reel Drum Assy.
216	2-B	25717484	Pressure Roller	252		25734448	Fixing Plate
217	3-F	25797045	Flywheel Assy.	253	4-F	25773529	Spring, Play Lock Lever
218	3-E	25717472	Holder Assy., Capstan	254	4-E	25776288	Spring, Play Lever
219		25754304	Reel Collet	255	4-D	25771806	Spring, Play Slider
220	3-B	25754383	Reel Drum	256	5-B	25783234	Mtg. Plate, Head
221		25754384	Reel Cap	257	3-F	25777071	Spring, Flywheel
222	3-B	25756241	Transfer Gear	258	5-B	22708523	Screw, BID Hd. 2d x 3mmi
223		25766050	Washer	259	3-F	25764486	Washer, Flywheel
224		25777033	Spring, Reel	260	4-A	22707923	Screw, BID Hd 2d x 6mmi
225	2-B	25713581	Lever Assy., Take-up	261	5-A	25748539	Lever, Erase Head
226	4-B	22757120	Steel Ball, 3mmd	262	5-B	25776142	Spring
227	4-A	22707669	Screw, BID Hd. 2d x 2mmi	263		25764597	Washer, Reel Drum
229	4-A	25772240	Spring Head	264	5-A	25735256	Washer, Erase Head
230	4-B	25779140	Spring Head Slider	265	2-H	25776313	Spring
231	5-A	25783258	Nut, Special	266	5-C	25776316	Spring
232	3-F	22707366	Screw, BID Hd. 2.6d x 6mmi	267	4-C	25741851	Adjusting Plate, Head
233	4-C	25782425	Lock Slider	268	4-B	25708524	Spacer, Adjusting Plate
234	4-G	25783226	Bush	269	4-B	22708524	Screw, BID Hd. 2d x 4mmi
235	4-B	20755722	Eject Lever Assy.	270	3-E	25735257	Washer Pad Pin
236	3-B	25762406	Friction Felt Shoe	271	2-D	22707301	Screw, BID Hd. Tapping 2.6d x 8mmi
237	3-B	25782418	Tension Lever	272	3-C	22708533	Screw, BID Hd. 2.6d x 8mmi
238	4-B	25783199	Washer, Tension Lever	273		22708525	Screw, BID Hd. 2d x 5mmi
239	4-C	22708529	Screw, BID Hd 2.6d x 4mmi	274	5-B	22707426	Screw, BID Hd. 2d x 5mmi
240		20798033	Ring	275	5-F	22708562	Washer, 3mmi
241	5-C	25741833	Slider, Play	277	4-H	22707445	Screw, BID Hd. 3d x 6mmi
242	4-F	25756248	Cam Gear, Play	278	3-G	25764593	Washer, Thrust
243	5-G	25782414	Lever, Solenoid	279	1-G	25766064	Sheet, Protector
				280	1-E	22753786	Washer

NOTE: The parts without part numbers are not supplied.

Semi-Conductor Lead Identifications

BA6218 : Q501

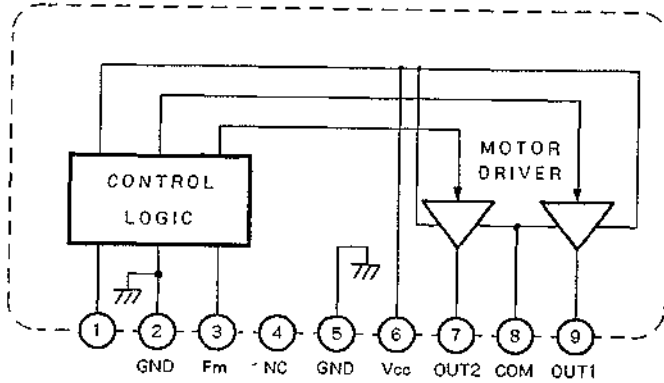
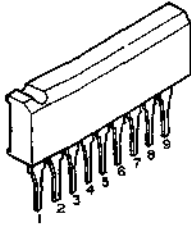

TC9310N060 : Q502

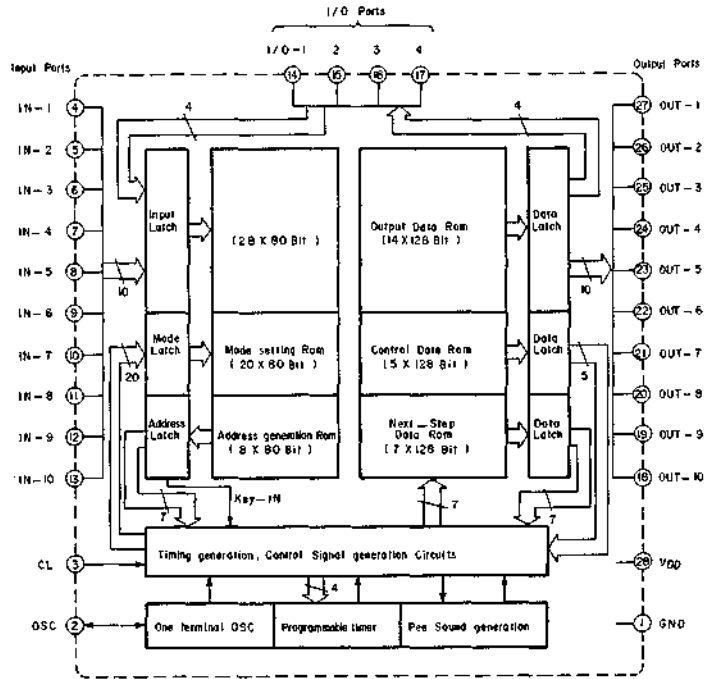
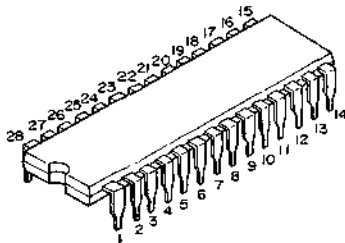

μ PD4071BC : Q503

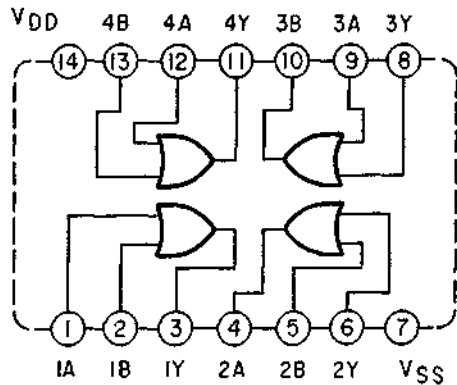
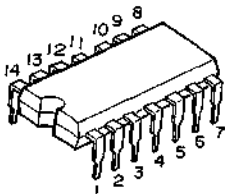

μ PD4069UBC : Q504

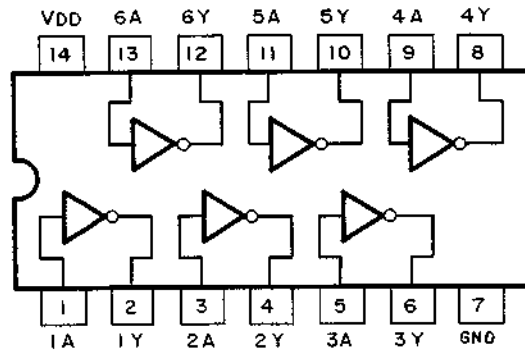
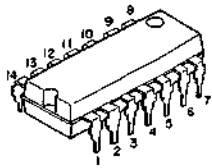

TC5067BP : Q505

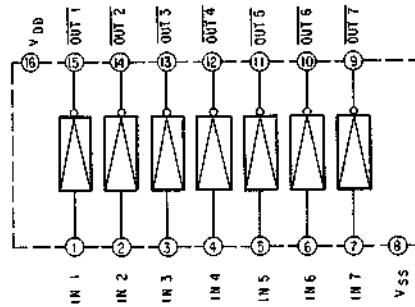
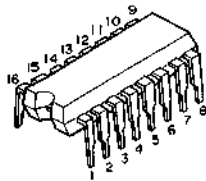

TC5054P : Q506

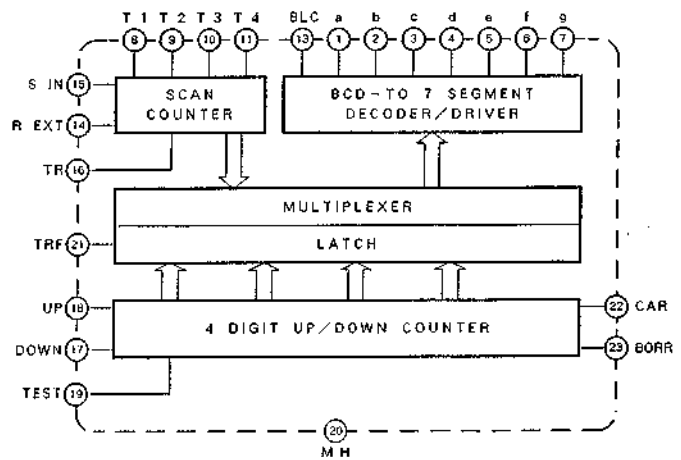
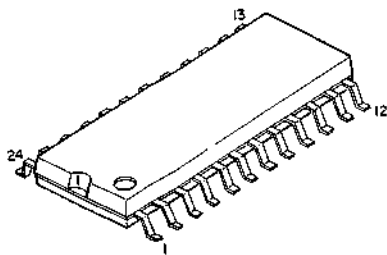

BU4069UB : Q509

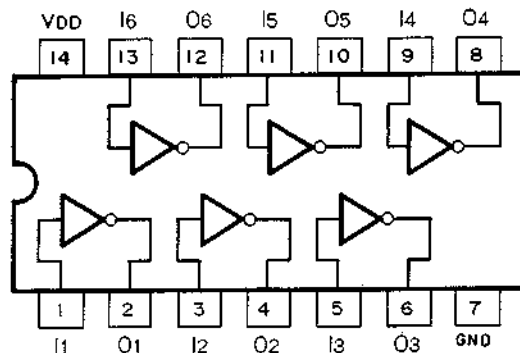
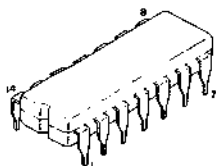

BU4013B : Q510

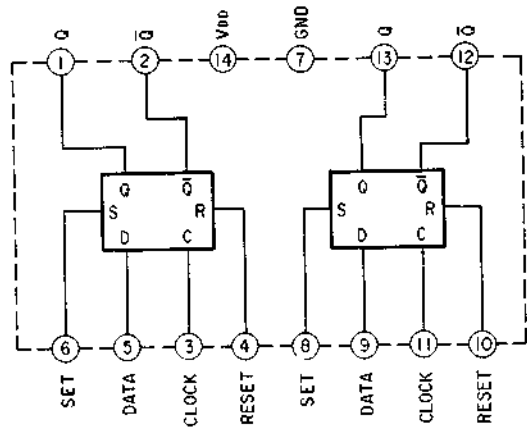
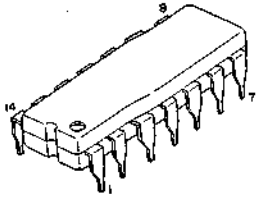

CX20187 : Q601, 702

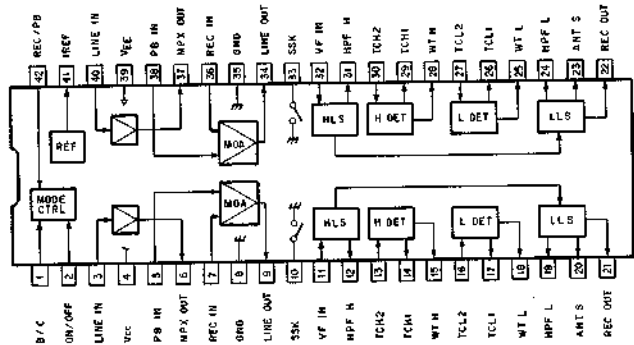
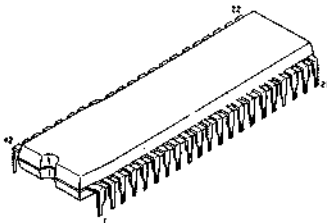

BA715 : Q602

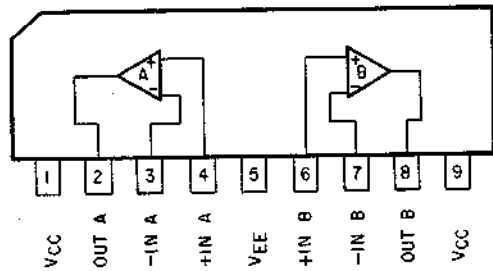
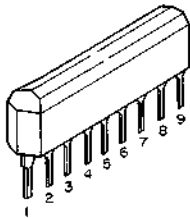

μ PC1297CA : Q603

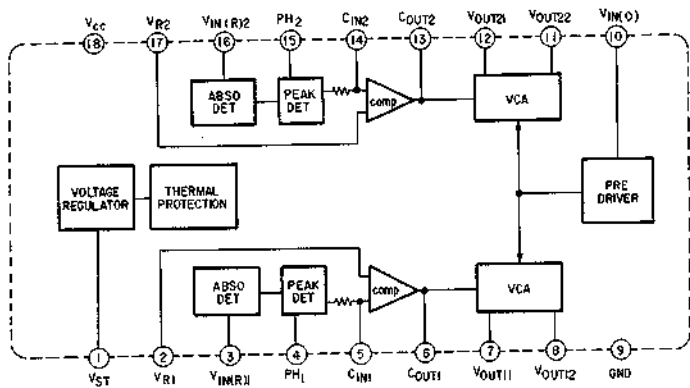
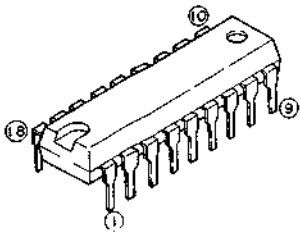

NJM2068SD : Q701
 NJM4556S : Q710

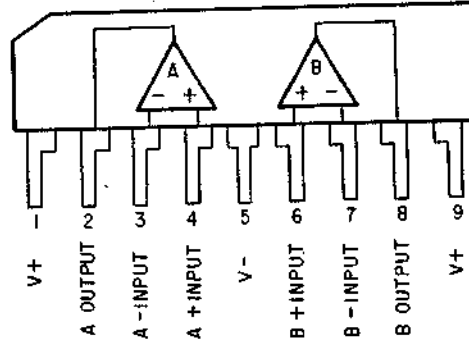
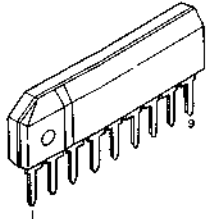

BU4066B : Q705

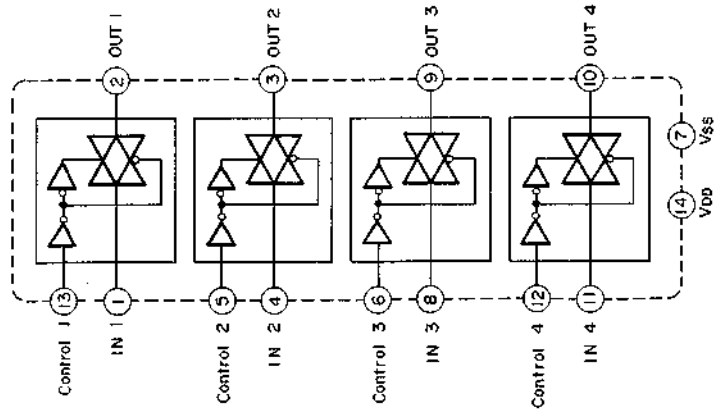
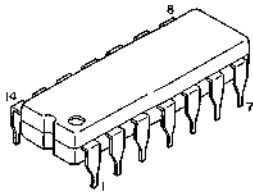

TA7666P : Q713

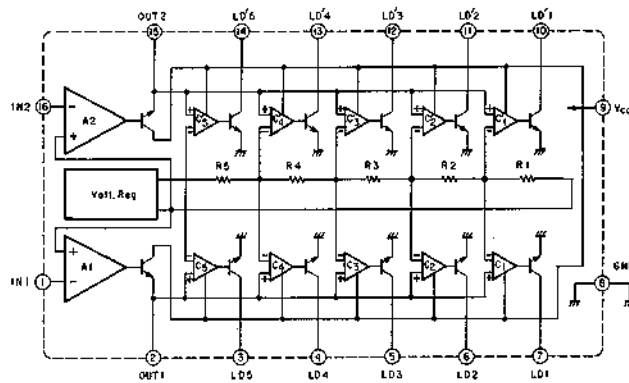
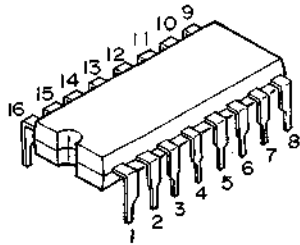

μ PD4050BG : Q902, 903

