

SERVICE MANUAL



Stereo Cassette Deck

K-92



Contents

Specifications	3
Parts Locations and Disassembly Instructions	4 to 7
Block Diagram	8
Adjustment Procedures	9 to 11
Adjustment Locations	12
Parts Layout on P.C. Boards and Wiring Diagram	13 to 16
Schematic Diagram (1/2)	17 to 19
Schematic Diagram (2/2)	20 to 22
Electrical Parts List	23 to 28
Packing Assembly Parts List	29
Packing Method View	29
Cabinet Assembly Parts List	30
Exploded View (Cabinet)	31 to 32
Exploded View (Cassette Deck)	33 to 34
Cassette Deck Assembly Parts List	35 to 36
Semi-Conductor Lead Identifications	37 to 39

Specifications

Power Source	AC 220/240V (50/60Hz)
Tape Speed (MTT-111).....	4.75cm/sec. +3%, - 2%
Wow & Flutter (MTT-111, JIS WRMS).....	≤ 0.11%
FF/REW Time (C-60)	≤ 105 sec.
Frequency Response (Playback, ± 4dB)	Normal : 40Hz-14kHz CrO2 : 40Hz-16kHz Metal : 40Hz-16kHz
S/N Ratio (Over all JIS Weighted "A" curve)	Dolby NR-OFF : Normal ≥ 50dB, CrO2/Metal ≥ 52dB Dolby NR-B : Normal/CrO2/Metal ≥ 57dB Dolby NR-C : Normal/CrO2 ≥ 63dB, Metal ≥ 65dB
Input Sensitivity	Line ≤ 100mV
Output Level at 0dB playback	Line : 500mV ± 1.5dB/47k ohm Headphone ≤ 100mV/8 ohm
Distortion 3rd (0dBm input at 333Hz).....	Normal : ≤ 2.5% CrO2/Metal : ≤ 3%
Semi-Conductors	14 IC's, 49 Transistors, 14 Diodes, 2 Zener Diodes, 17 LED's
Chassis Dimensions	438(W) x 100(H) x 250(D) mm
Weight	3.8 kg

NOTE: Due to continuing product improvement, specifications and designs are subject to change without notice.

Parts Locations and Disassembly Instructions

Figure 1

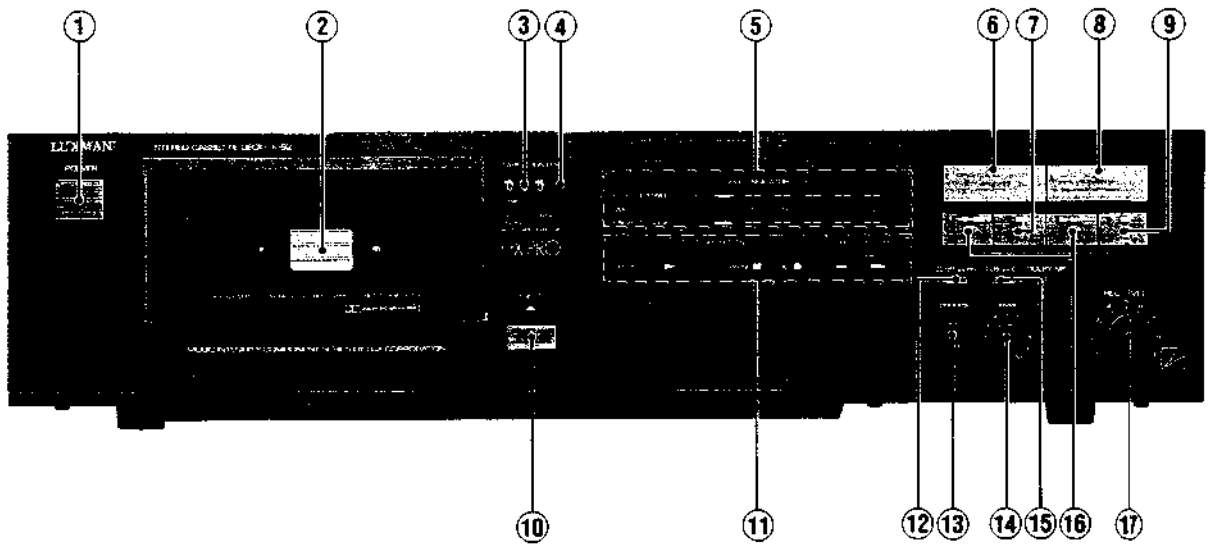
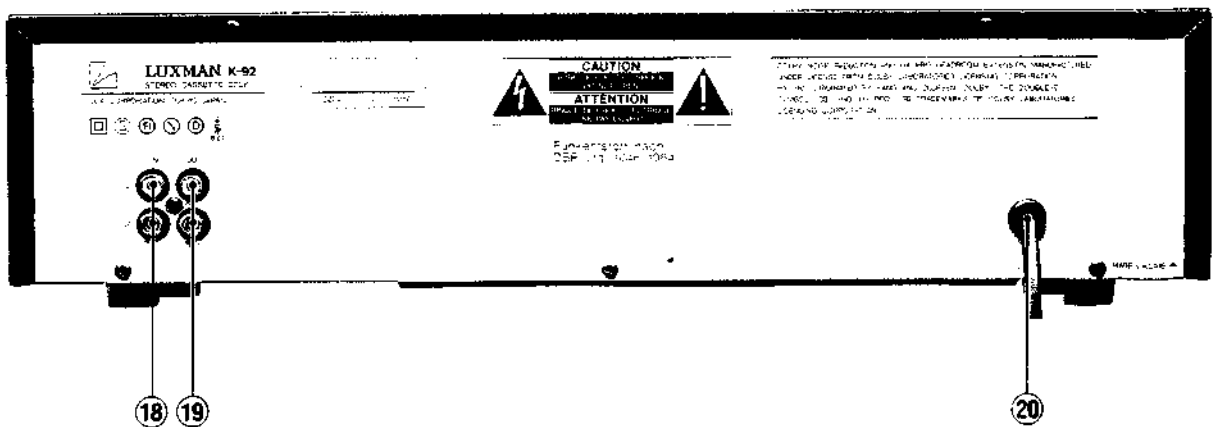
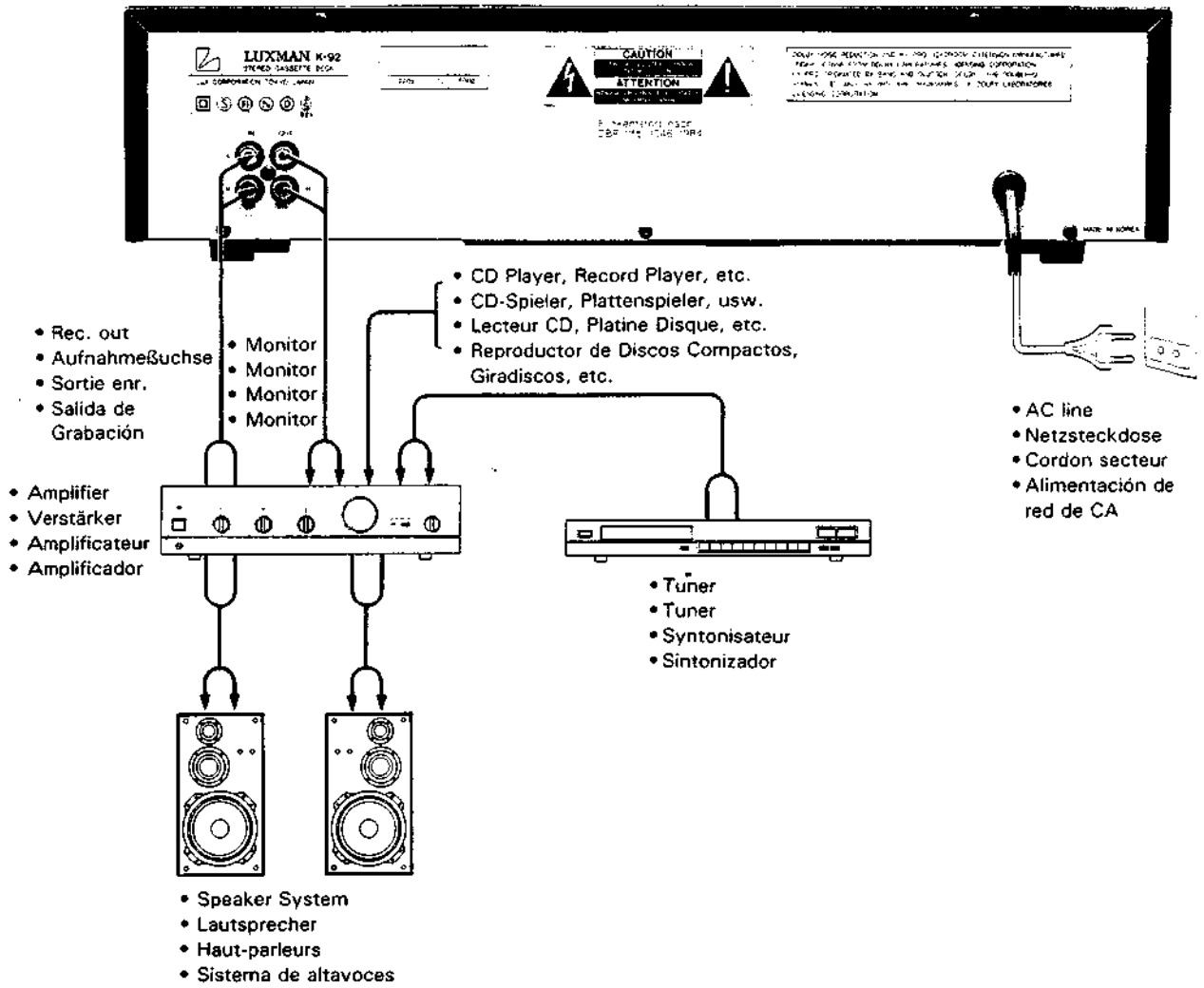

Figure 2



- | | |
|-----------------------------|----------------------------------|
| ① Power Button | ⑪ Function Indicators |
| ② Cassette Door | ⑫ Dolby NR ON/OFF Button |
| ③ Tape Counter | ⑬ Phones Jack |
| ④ Tape Counter Reset Button | ⑭ Level Control Knob |
| ⑤ Level Indicators | ⑮ Dolby NR Select (B/C) Button |
| ⑥ Play Button (▶) | ⑯ Fast Forward and Rewind Button |
| ⑦ Stop Button (■) | ⑰ Rec Level Control Knob |
| ⑧ Pause Button (⏸) | ⑱ Input Jacks |
| ⑨ Record Button (●) | ⑲ Output Jacks |
| ⑩ Eject Button (▲) | ⑳ AC Power Cord |

Figure 3



1. Removal of Top Cabinet (Figure 4)

- (1) Remove four screws marked (A) and four screws marked (B).
- (2) Slide off the top cabinet, stretching the both sides slightly outside.

2. Removal of Front Panel (Figure 5)

- (1) Remove the top cabinet as shown above.
- (2) Disconnect all connectors from the main P.C. Board and the cassette deck.
- (3) Turn the unit upside down, and remove four screws marked (C) and three nylon rivets marked (D) from the bottom cabinet.
- (4) Remove the front panel by pulling it.

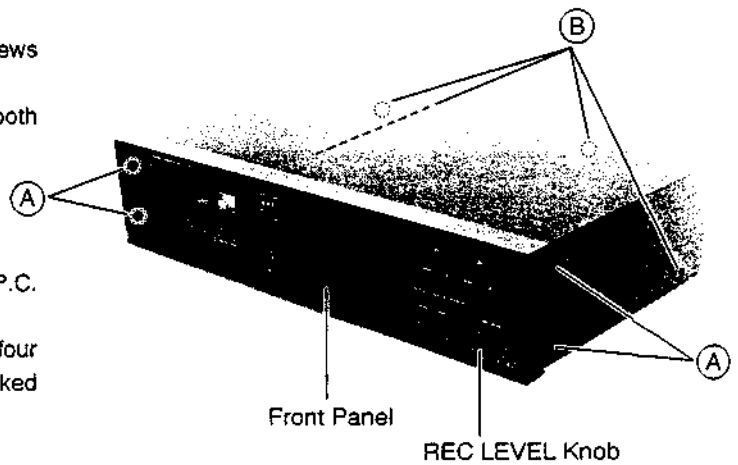

Figure 4

3. Removal of Cassette Deck Mechanism (Figure 6)

- (1) Remove the front panel as shown above.
- (2) Open the cassette door by pressing the EJECT button.
- (3) To remove the cassette deck mechanism, remove the belt from the counter pulley on the mechanism. (Be carefull not to miss the belt.)
- (4) Remove four black screws (E) from the cassette deck mechanism.
- (5) Remove the cassette deck mechanism from the front panel. Be careful not to miss the slider with spacer and screw (shown by * in Figure 6) when removing the mechanism.

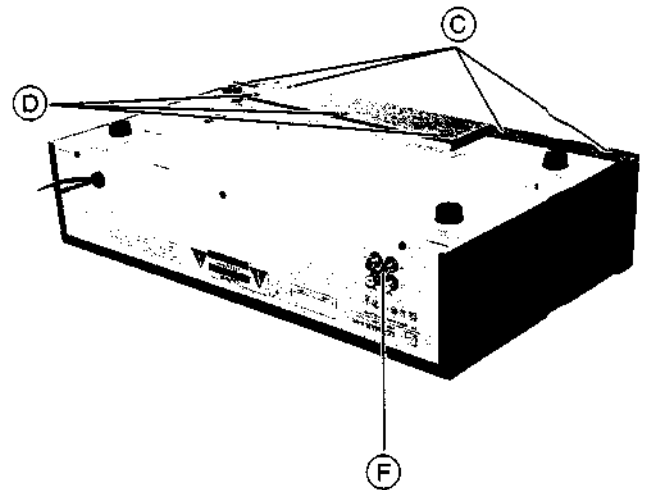

Figure 5

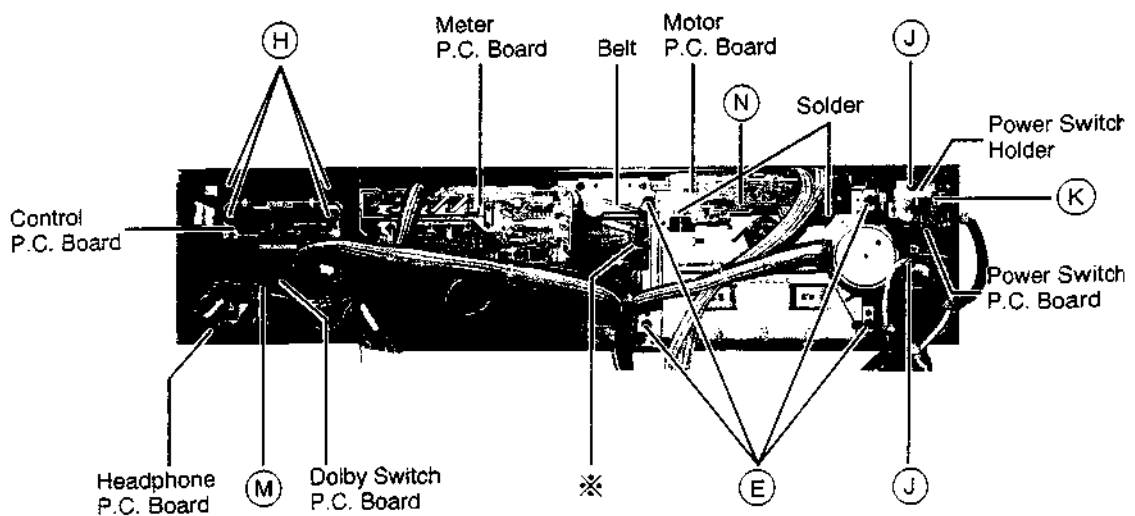

Figure 6

4. Removal of Main P.C. Board (Figures 5 and 7)

- (1) Remove the top cabinet.
- (2) Disconnect all connectors from the main P.C. Board and the cassette deck.
- (3) Remove a screw (F) from the RCA jack section. (Figure 5)
- (4) Remove four screws (G) from the P.C. Board. (Figure 7)

5. Removal of Control P.C. Board (Figure 6)

- (1) Remove the front panel.
- (2) Remove four screws (H) from the P.C. Board.

6. Removal of Power Switch P.C. Board (Figure 6)

- (1) Remove the front panel.
- (2) Make sure that the power switch is off (not depressed.)
- (3) Remove two screws (J) that secure the power switch holder.
- (4) Pull the power switch P.C. Board with the holder strongly backward to remove the power switch shaft from the power switch knob.
- (5) Remove one screw (K) from the holder.

7. Removal of Dolby Switch P.C. Board (Figure 8)

- (1) Remove the front panel.
- (2) Remove two screws (L) from the P.C. Board.

8. Removal of Headphone P.C. Board (Figures 4 and 6)

- (1) Remove the front panel.
- (2) Remove REC LEVEL knob from the front panel by pulling it. (Figure 4)
- (3) You will find a nut with a washer in the hole after removing the REC LEVEL knob. Remove the nut and washer.
- (4) Remove one screw (M) from the headphone holder. (Figure 6)

9. Removal of Meter P.C. Board (Figure 6)

- (1) Remove the front panel.
- (2) Remove the P.C. Board by stretching the four detents slightly that secure the P.C. Board to the frame.

10. Removal of Motor P.C. Board (Figures 6 and 7)

- (1) Remove the cassette deck mechanism.
- (2) Remove three screws (N) from the P.C. Board.
- (3) Unsolder the two solenoids and remove the P.C. Board.

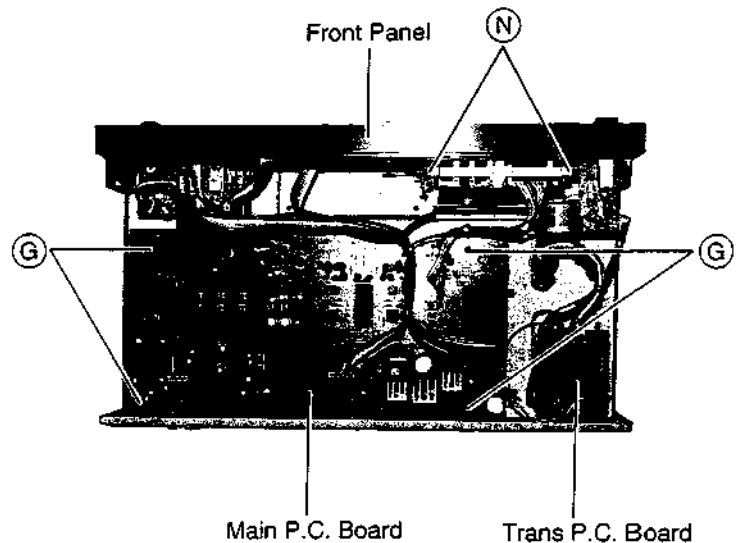

Figure 7

Dolby Switch
P.C. Board

Figure 8

Block Diagram

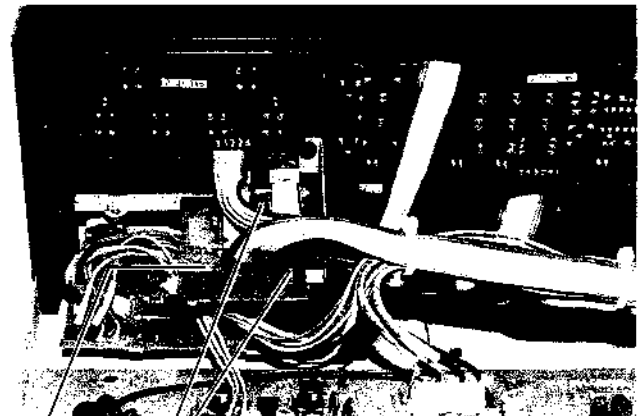
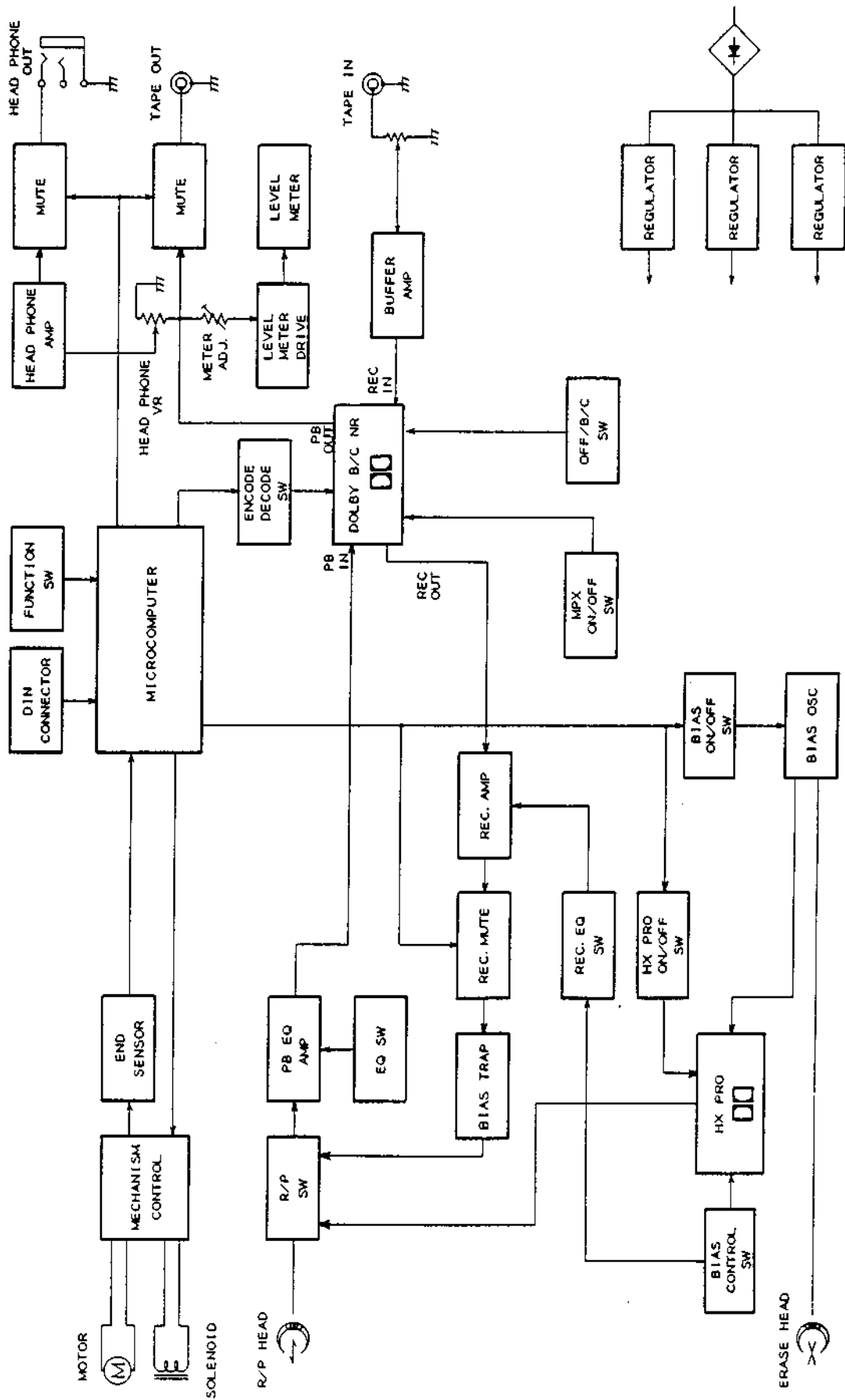

Adjustment Procedures

TEST EQUIPMENTS

1. VTVM (Vacuum Tube Voltmeter)
2. Signal Generator
3. Resistance Attenuator
4. Screwdriver
5. Frequency Counter

6. Test Tapes

- MTT-111 (Speed 3kHz)
- MTT-114 (Azimuth 10kHz)
- MTT-150 (Dolby 400Hz Modulation)
- AC-223 (Normal Tape : Blank)
- AC-512 (CrO2 Tape : Blank)
- AC-712 (Metal Tape : Blank)

No.	Adjustment Item	Test Value	Test Tape	Rec. Volume Control VR802	Switch Position			Adjustable Parts	Test Point	Input Frequency	Equipment/Connection	Remarks
					NR	NR B or C	Input					
1	Head Azimuth Adjustment	Maximum	MTT-114	—	OFF	—	—	Adjustment Screw	TAPE OUT	—	VTVM See Fig. 9	Apply lock paint after adjustment.
2	Tape Speed (Normal Speed)	$3000 \pm 30\text{Hz}$	MTT-111	—	OFF	—	—	VR845	TAPE OUT	—	Frequency Counter	Check at the halfway point of the tape length.
3	Playback Sensitivity Adjustment	$500 \pm 10\text{mV}$	MTT-150	—	OFF	—	—	VR101 (L) VR102 (R)	TAPE OUT	—	See Fig. 10	—
4	Bias Oscillator Frequency Adjustment	$105 \pm 0.5\text{kHz}$	AC-223	—	OFF	—	—	L209	HOT : TP-1 GND : TP-2	—	See Fig. 11	Adjust in REC mode.
5	Bias Trap Adjustment	Minimum	AC-223	—	OFF	—	—	Lch L205 Rch L206	HOT : TP-5 GND : TP-7 HOT : TP-6 GND : TP-7	—	VTVM	Adjust in REC mode.
6	Bias Current Adjustment	$5.2 \pm 0.1\text{mV}$	AC-223	—	OFF	—	—	Lch/Rch VR207/VR208	Lch HOT : TP-1 GND : TP-2 Rch HOT : TP-3 GND : TP-4	—	VTVM	Adjust in REC mode.
		$6.2 \pm 0.1\text{mV}$	AC-512					Lch/Rch VR205/VR206				
		$11 \pm 0.2\text{mV}$	AC-712					Lch/Rch VR203/VR204				
7	Rec. Level Meter Sensitivity Adjustment	+3dB	AC-223	Maximum	OFF	—	TAPE IN	Lch VR815 Rch VR816	Lch HOT : TP-12 GND : TP-14 Rch HOT : TP-13 GND : TP-14	400Hz	VTVM	Adjust VR815/816 so that the +3dB point ( mark) on the level meter lights dimly. (Input level at 90mV -1.5dB).
8	Rec. Sensitivity Adjustment	$160\text{mV} \pm 0.5\text{dB}$	AC-223	Maximum	OFF	—	TAPE IN	Lch VR209 Rch VR210	Lch HOT : TP-15 GND : TP-7 Rch HOT : TP-16 GND : TP-7	400Hz	See Fig. 12	Adjust VR209/210 so that TP15-7/16-7 measure $100\text{mV} \pm 0.5\text{dB}$. When supply the input level at 90mV, check that TAPE OUT for $500\text{mV} \pm 40\text{mV}$.
9	Rec./PB Frequency Response Adjustment	$0 \pm 1\text{dB}$	AC-223 AC-512 AC-712	Maximum	OFF	—	TAPE IN	Lch/Rch VR207/VR208 Lch/Rch VR205/VR206 Lch/Rch VR203/VR204	TAPE OUT	400Hz 10kHz	See Fig. 13	Adjust TAPE OUT for $500\text{mV} - 25\text{dB}$ first by resistance attenuator. Then adjust VRs 203-208 so that the rec/play level is $0 \pm 1\text{dB}$.
Measurement Conditions		<ul style="list-style-type: none"> ● Power Supply : AD=220V (50Hz) ● Input : 0dB=1Vrms ● TAPE IN (Signal Generator Output Impedance) : 600 ohms ● TAPE OUT (Load Impedance) : 47k ohms ● HEADPHONE OUT (Load Impedance) : 8 ohms ● Test Point Load Impedance : No load 										

Figure 9 HEAD AZIMUTH ADJUSTMENT

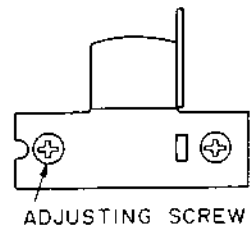

Figure 10 PLAYBACK SENSITIVITY ADJUSTMENT

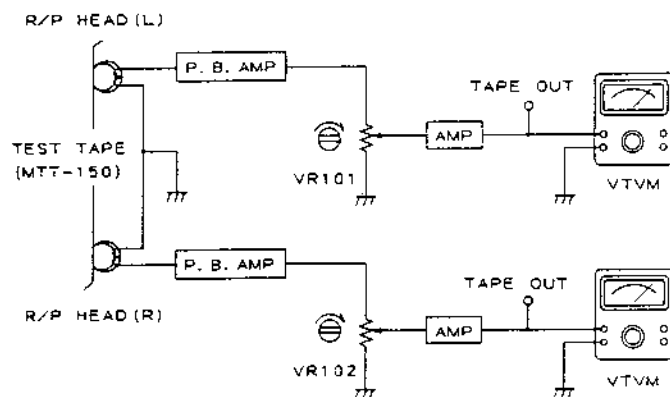

Figure 11 BIAS OSCILLATOR FREQUENCY ADJUSTMENT

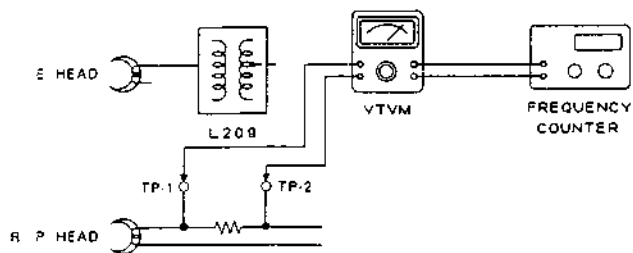

Figure 12 RECORD SENSITIVITY ADJUSTMENT

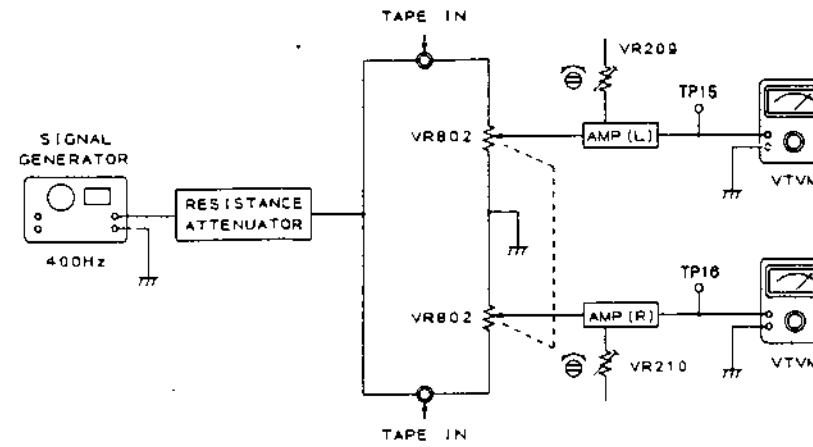
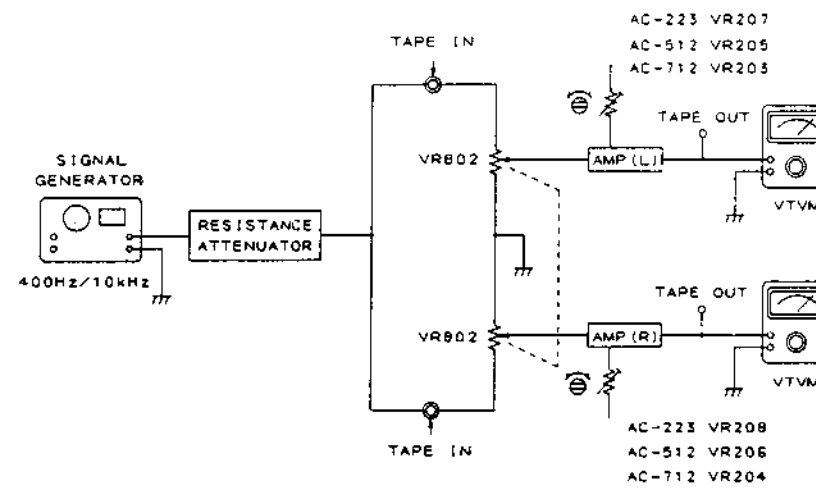
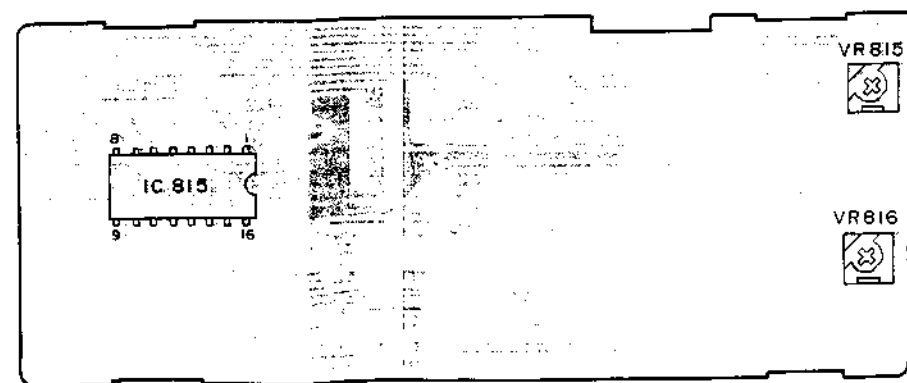

Figure 13 RECORD/PLAYBACK FREQUENCY RESPONSE ADJUSTMENT



Adjustment Locations



Meter P.C. Board

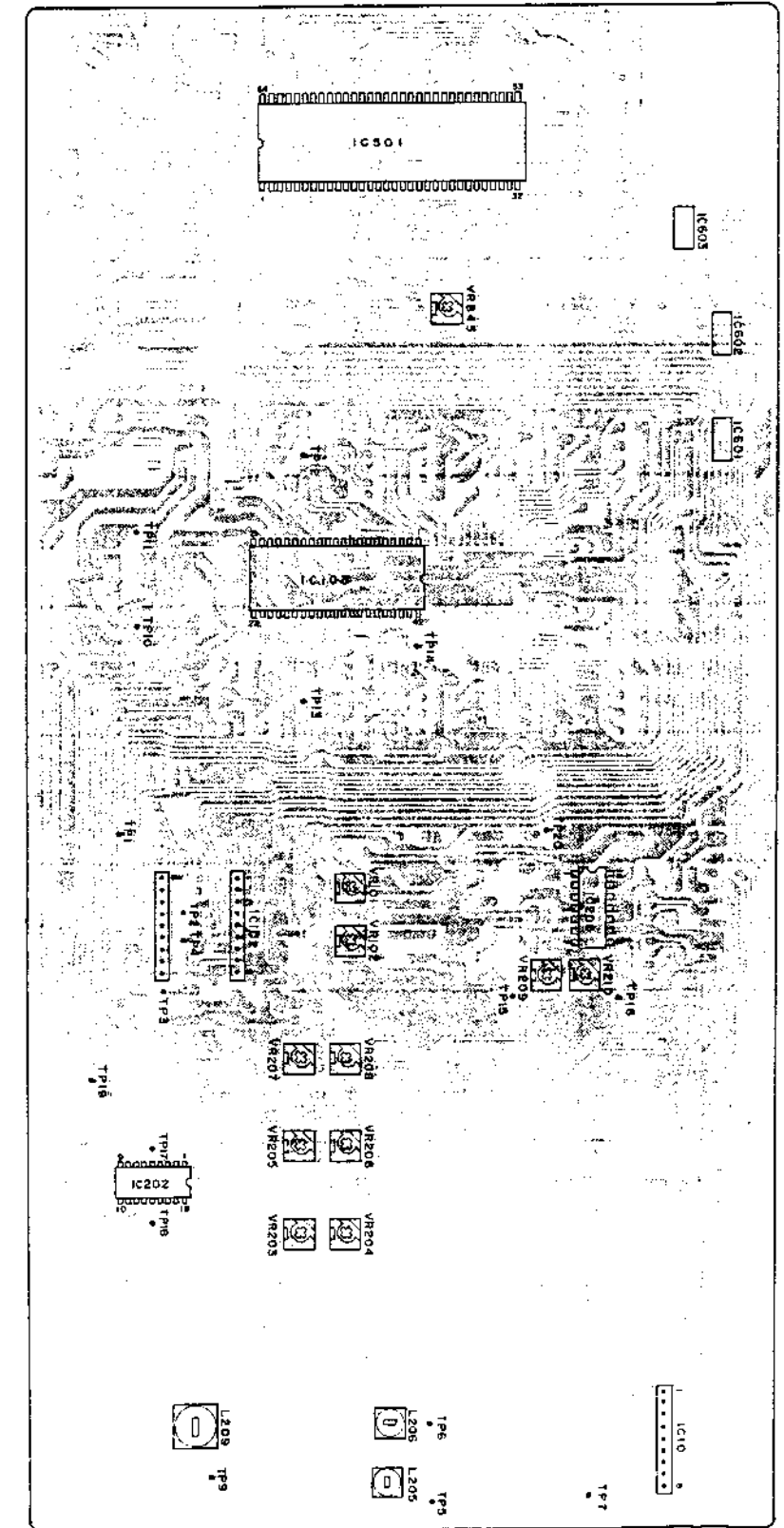

Main P.C. Board

Parts Layout on P.C. Boards and Wiring Diagram

1
2
3
4
5

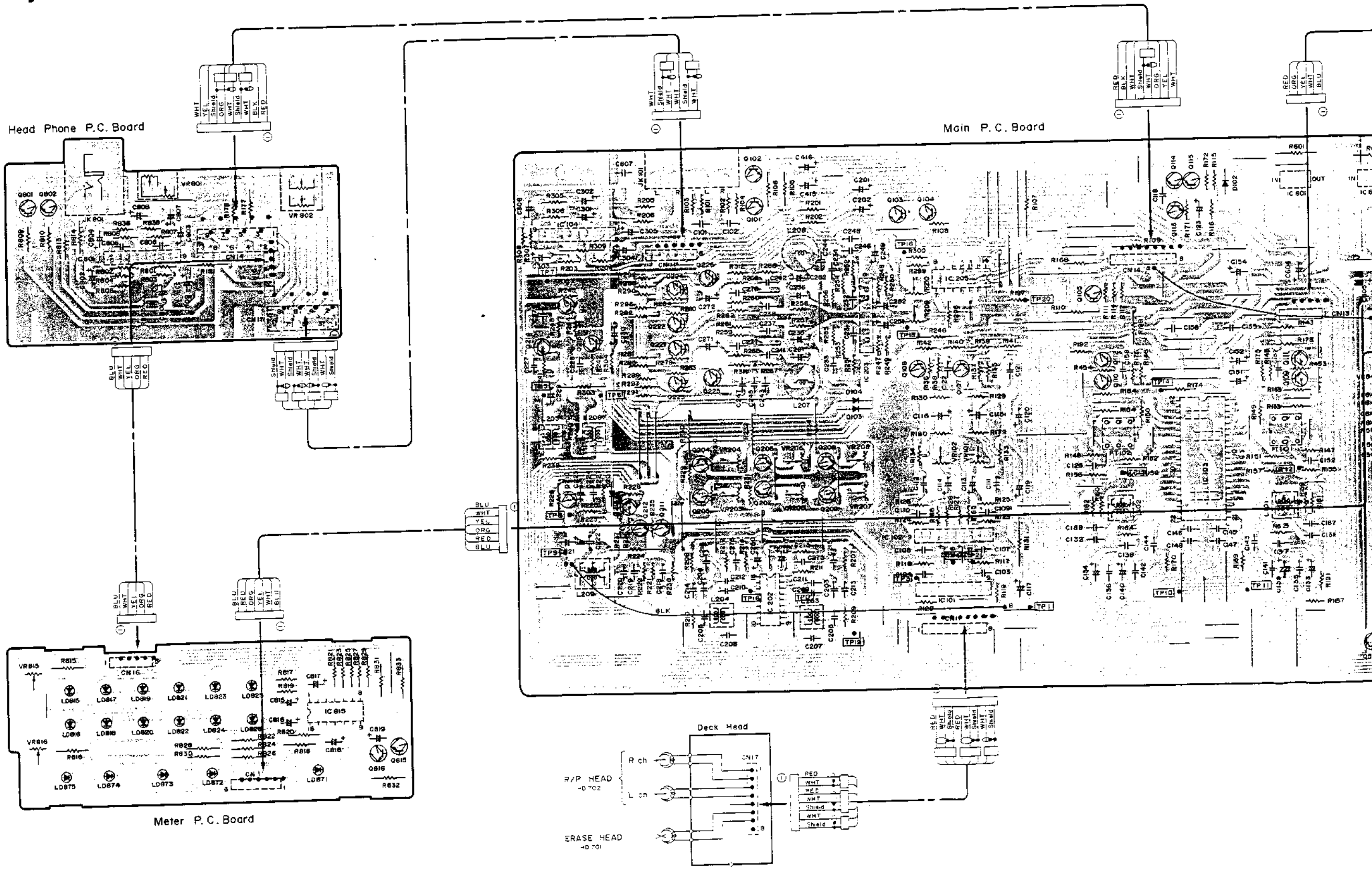

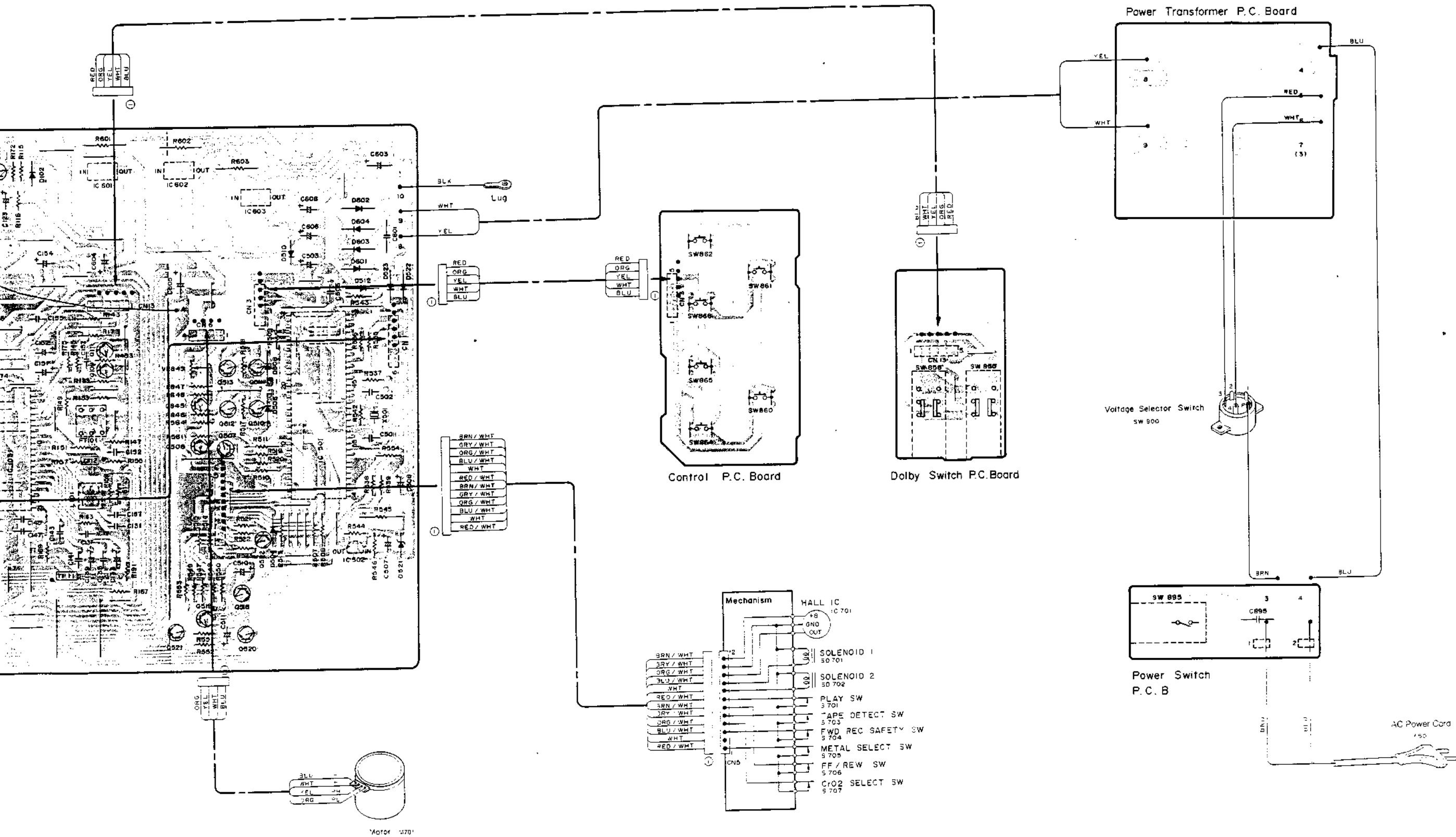

Schematic Diagram (1/2)

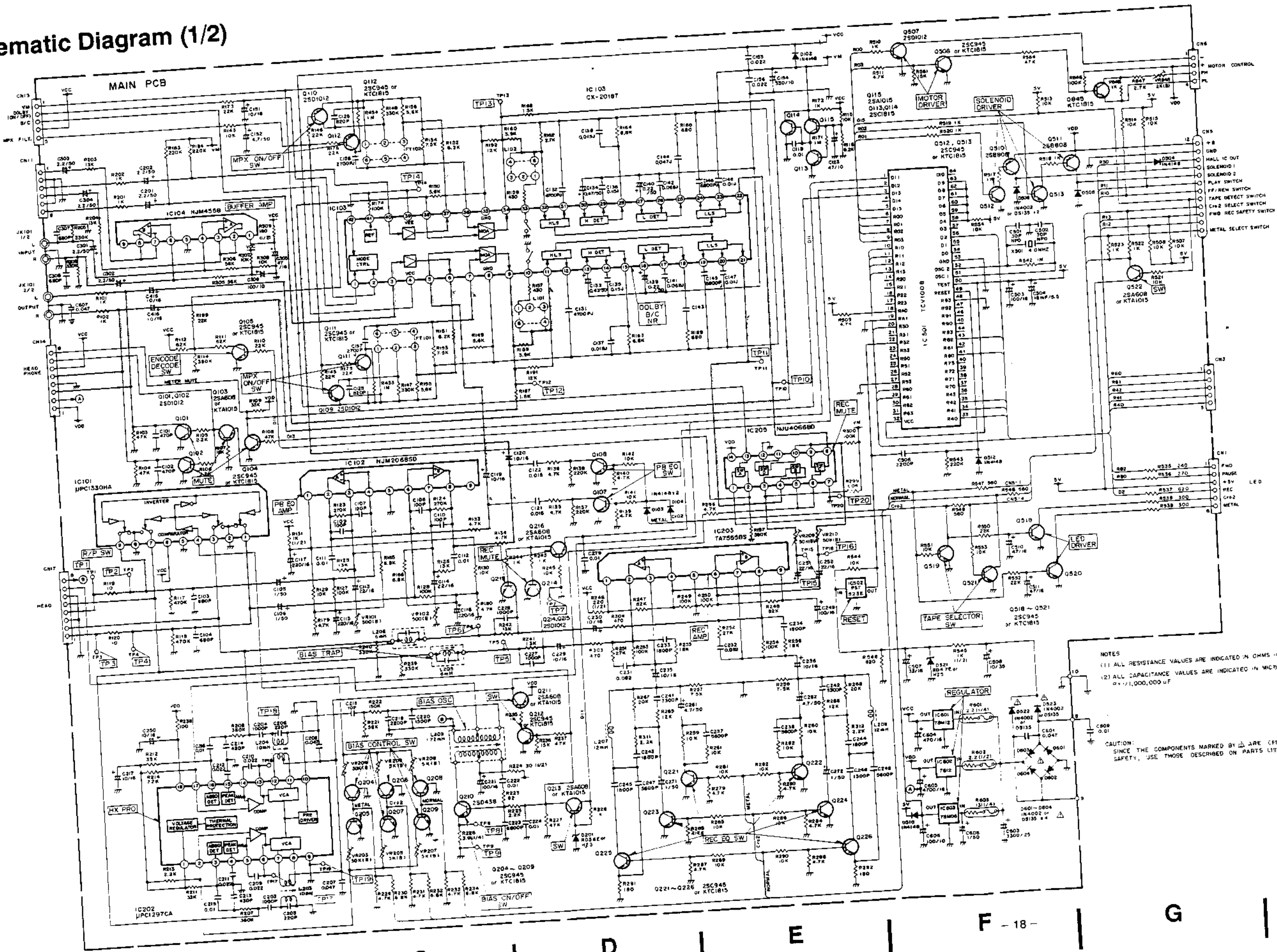

NOTES
 (1) ALL RESISTANCE VALUES ARE INDICATED IN OHMS $\pm 1, 0.001$
 (2) ALL CAPACITANCE VALUES ARE INDICATED IN MICROFARADS.
 0.1 = 100,000.00 pF

CAUTION:
 SINCE THE COMPONENTS MARKED WITH Δ ARE CRITICAL FOR
 SAFETY, USE THOSE DESCRIBED ON PARTS LIST ONLY.

Pin No.	IC101
1	5V
2	0V
3	0V
4	4.4V
5	0V
6	12.0V
7	0V
8	0V
9	0V

Pin No.	IC102
1	7.5V
2	5.8V
3	3.0V
4	4.5V
5	0V
6	4.8V
7	5.0V
8	5.1V
9	7.0V

Pin No.	R No.
1	4
2	1
3	7
4	4
5	5
6	8
7	9
8	6
9	10
10	11
11	12
12	13
13	14
14	15
15	16
16	17
17	18
18	19

Pin No.	R No.
1	4
2	1
3	7
4	4
5	5
6	8
7	9
8	6
9	10
10	11
11	12
12	13
13	14
14	15
15	16
16	17
17	18
18	19

Pin No.	R No.
1	4
2	1
3	7
4	4
5	5
6	8
7	9
8	6
9	10
10	11
11	12
12	13
13	14
14	15
15	16
16	17
17	18
18	19

Pin No.	R No.
1	4
2	1
3	7
4	4
5	5
6	8
7	9
8	6
9	10
10	11
11	12
12	13
13	14
14	15
15	16
16	17
17	18
18	19

Pin No.	R No.
1	4
2	1
3	7
4	4
5	5
6	8
7	9
8	6
9	10
10	11
11	12
12	13
13	14
14	15
15	16
16	17
17	18
18	19

Pin No.	R No.
1	4
2	1
3	7
4	4
5	5
6	8
7	9
8	6
9	10
10	11
11	12
12	13
13	14
14	15
15	16
16	17
17	18
18	19

Pin No.	R No.
1	4
2	1
3	7
4	4
5	5
6	8
7	9
8	6
9	10
10	11
11	12
12	13
13	14
14	15
15	16
16	17
17	18
18	19

1
2
3
4
5

C D E F G H

Schematic Diagram (2/2)

1

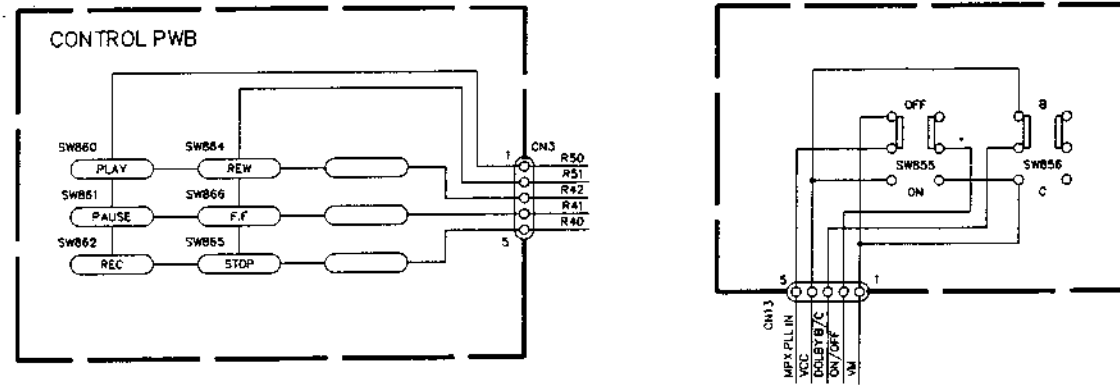

2

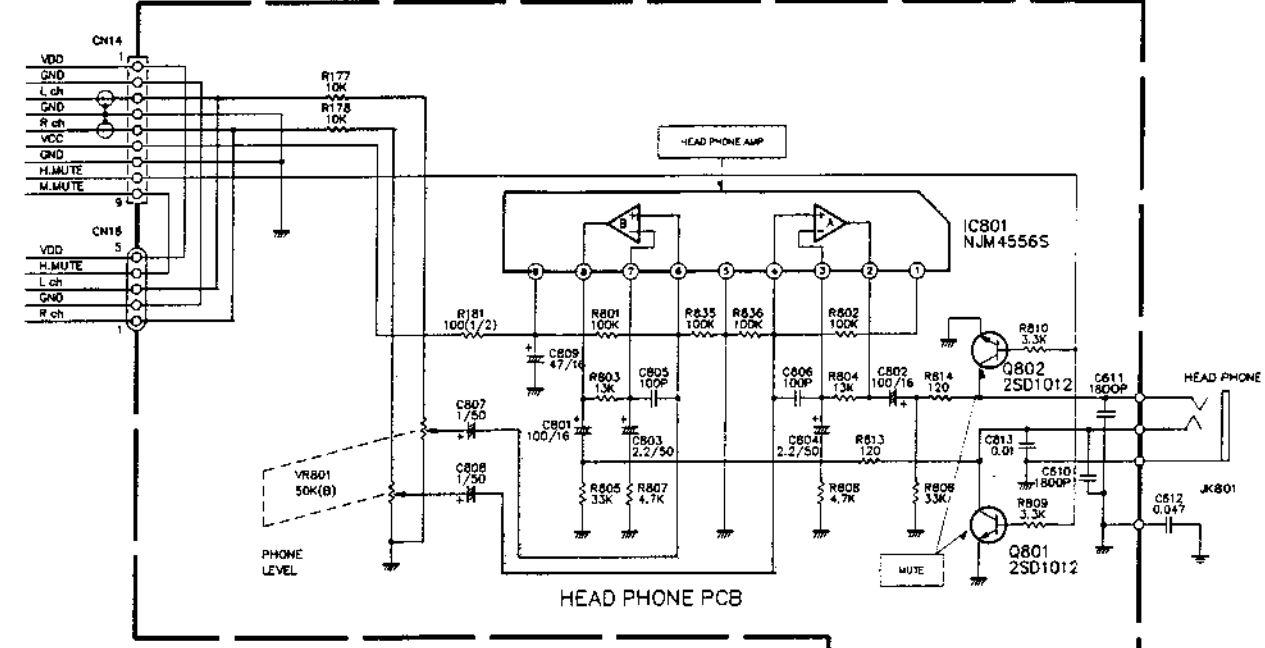

3

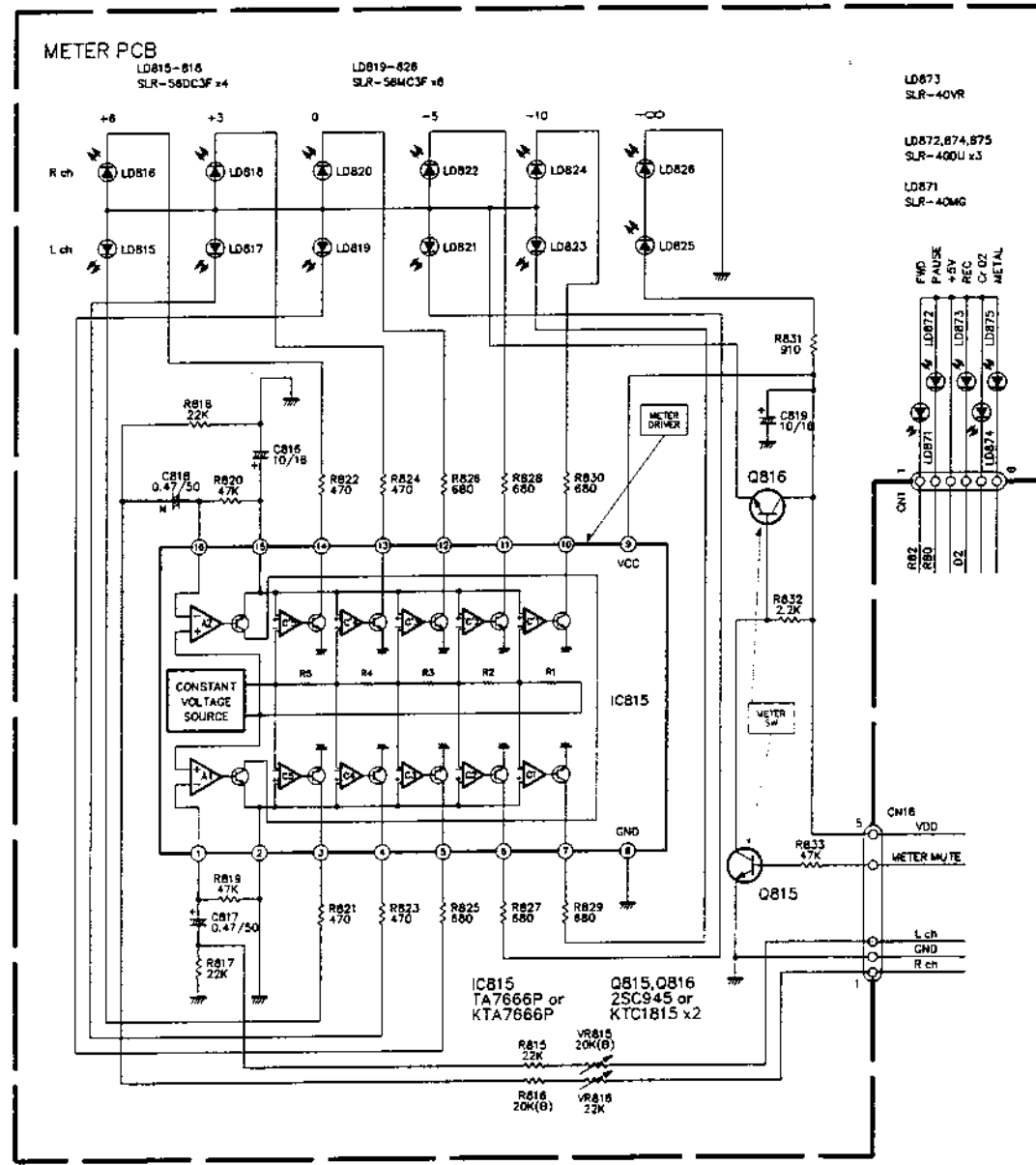

4

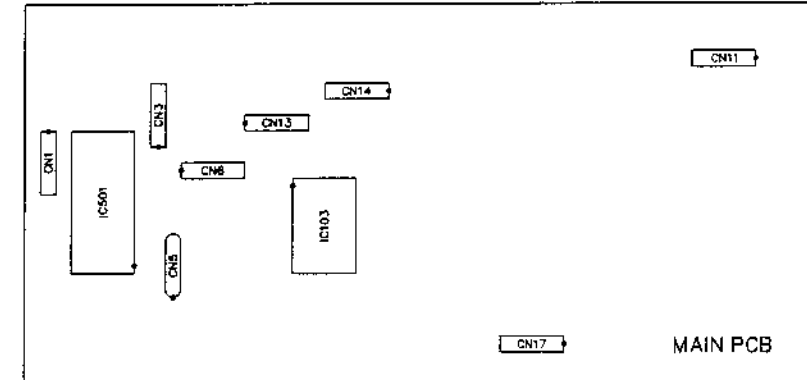

5

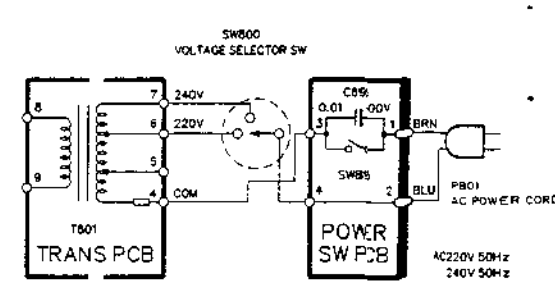
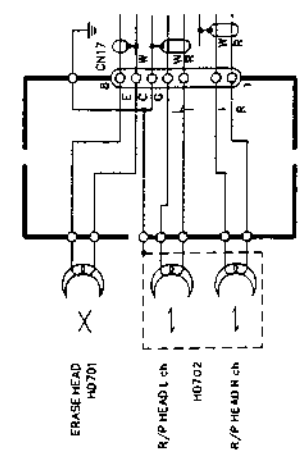
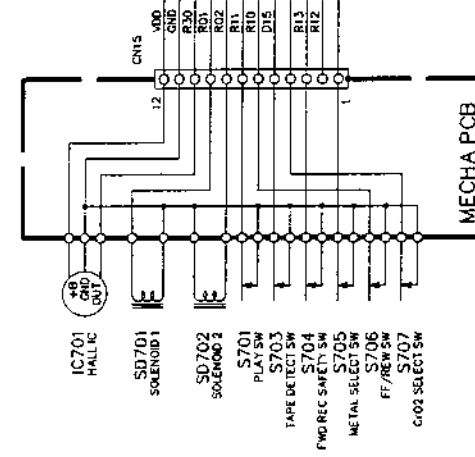

Electrical Parts List

Resistor : Carbon resistors under 1/4 watts are not mentioned in the parts list, please confirm them by schematic diagram.
 Capacitor : μF = microfarads, pF = picofarads

Abbreviations					Symbol No.	Part No.	Description		
RES. = Resistor C.F. = Carbon Film M.F. = Metal Film M.O. = Metal Oxide Film M.P. = Metal Plate CTM. = Cement Resistor TR. = Transistor TRANS. = Transformer CP. = Chip CAP. = Capacitor ELY. = Electrolytic CER. = Ceramic MYL. = Mylar TAN. = Tantalum POLY. = Polystyrol PP. = Polypropylene PLT. = Polyethylene STR. = Styrene M-PL. = M-Plastic									
Symbol No.	Part No.	Description							
Main P. C. Board									
IC's									
IC101	51E05529S01	μ PC1330HA			Q113	48E05542S01	2SC945		
IC102	51T73021F02	NJM2068SD			or	48E04784S04	KTC1815		
IC103	51E05539S01	CX20187			Q114	48E05542S01	2SC945		
IC104	51E05531S01	NJM4558S (D)			or	48E04784S04	KTC1815		
IC202	51T72929F01	μ PC1297CA			Q115	48T65363F02	2SA608		
					or	48E04785S03	KTA1015		
IC203	51E05533S01	TA75558S			Q204	48E05542S01	2SC945		
IC205	51E05532S01	NUJ4066BD			or	48E04784S04	KTC1815		
IC501	51E05534S01	TV1008 614042SK01			Q205	48E05542S01	2SC945		
IC502	51E05535S01	PST523E			or	48E04784S04	KTC1815		
IC601	51E05536S01	MC78M12CT			Q206	48E05542S01	2SC945		
					or	48E04784S04	KTC1815		
IC602	51T94884F04	MC7812CT			Q207	48E05542S01	2SC945		
IC603	51E05537S01	MC78M06CT			or	48E04784S04	KTC1815		
					Q208	48E05542S01	2SC945		
					or	48E04784S04	KTC1815		
					Q209	48E05542S01	2SC945		
					or	48E04784S04	KTC1815		
					Q210	48T58776F02	2SD438		
					Q211	48T65363F02	2SA608		
					or	48E04785S03	KTA1015		
					Q212	48E05542S01	2SC945		
					or	48E04784S04	KTC1815		
					Q213	48T65363F02	2SA608		
					or	48E04785S03	KTA1015		
					Q214	48E05541S01	2SD1012		
					Q215	48E05541S01	2SD1012		
					Q216	48T65363F02	2SA608		
					or	48E04785S03	KTA1015		
					Q221	48E05542S01	2SC945		
					or	48E04784S04	KTC1815		
					Q222	48E05542S01	2SC945		
					or	48E04784S04	KTC1815		
					Q223	48E05542S01	2SC945		
					or	48E04784S04	KTC1815		
					Q224	48E05542S01	2SC945		
					or	48E04784S04	KTC1815		
					Q225	48E05542S01	2SC945		
					or	48E04784S04	KTC1815		
					Q226	48E05542S01	2SC945		
					or	48E04784S04	KTC1815		
Q101	48E05541S01	2SD1012			Q507	48E05541S01	2SD1012		
Q102	48E05541S01	2SD1012			Q508	48E05542S01	2SC945		
Q103	48T65363F02	2SA608			or	48E04784S04	KTC1815		
or	48E04785S03	KTA1015			Q510	48E05543S01	2SB808		
Q104	48E05542S01	2SC945			Q511	48E05543S01	2SB808		
or	48E04784S04	KTC1815							
Q105	48E05542S01	2SC945							
or	48E04784S04	KTC1815							
Q107	48E05542S01	2SC945							
or	48E04784S04	KTC1815							
Q108	48E05542S01	2SC945							
or	48E04784S04	KTC1815							
Q109	48E05541S01	2SD1012							
Q110	48E05541S01	2SD1012							
Q111	48E05542S01	2SC945							
or	48E04784S04	KTC1815							
Q112	48E05542S01	2SC945							
or	48E04784S04	KTC1815							

Symbol No.	Part No.	Description			Symbol No.	Part No.	Description		
Q512 or Q513 or Q518 or	48E05542S01 48E04784S04 48E05542S01 48E04784S04 48E05542S01 48E04784S04	2SC945 KTC1815 2SC945 KTC1815 2SC945 KTC1815			D603 or D604 or	48S40477U02 48T44992F01 48S40477U02 48T44992F01	1N4002 DS135D 1N4002 DS135D		
Q519 or Q520 or Q521 or	48E05542S01 48E04784S04 48E05542S01 48E04784S04 48E05542S01 48E04784S04	2SC945 KTC1815 2SC945 KTC1815 2SC945 KTC1815			Coils/Inductors				
Q522 or Q845 or	48T65363F02 48E04785S03 48E05542S01 48E04784S04	2SA808 KTA1015 2SC945 KTC1815			L101 L102 L203 L204 L205	24E05523S01 24E05523S01 24E07997S01 24E07997S01 24E05525S01	Coil 22mH Coil 22mH Coil 10mH Coil 10mH Coil 6mH		
Diodes					L206 L207 L208 L209	24E05525S01 24E05526S01 24E05526S01 24E05527S01	Coil 6mH Inductor 12mH Inductor 12mH Coil 1.72mH		
D102 D103 D104 D201 or	48E04616S01 48E04616S01 48E04616S01 48T40732F08 48T52739F15	1N4148 1N4148 1N4148 Zener, RD3.6E Zener, HZ3-C3			Filters				
D504 D506 or D508 or	48E04616S01 48S40477U02 48T44992F01 48S40477U02 48T44992F01	1N4148 1N4002 DS135D 1N4002 DS135D			FT101 FT102	91E05528S01 91E05528S01	10PD MPX 10PD MPX		
D510 D512 D521 or D522 or	48E04616S01 48E04616S01 48T56372F21 48T52739F28 48S40477U02 48T44992F01	1N4148 1N4148 Zener, RD4.7E Zener, HZ5B-1 1N4002 DS135D			Jack				
D523 or D601 or D602 or	48S40477U02 48T44992F01 48S40477U02 48T44992F01 48S40477U02 48T44992F01	1N4002 DS135D 1N4002 DS135D 1N4002 DS135D			JK101	09E07996S01	RCA Jack		
Resonator					X501	48E05503S01	Resonator 4MHz		

Symbol No.	Part No.	Description			Symbol No.	Part No.	Description		
Capacitors									
C101	21E04638S02	CER.,	470pF		C154	23E06052S02	ELY.,	330 μ F/10V	
C102	21E04638S02	CER.,	470pF		C155	08E04735S09	MYL.,	0.022 μ F	
C103	21E04734S02	CER.,	680pF		C156	08E04735S09	MYL.,	0.022 μ F	
C104	21E04734S02	CER.,	680pF		C157	08E04735S10	MYL.,	2700pF	
C105	23E04635S03	ELY.,	1 μ F/50V		C158	08E04735S10	MYL.,	2700pF	
C106	23E04635S03	ELY.,	1 μ F/50V		C201	23E04635S08	ELY.,	2.2 μ F/50V	
C107	21E04638S03	CER.,	100pF		C202	23E04635S08	ELY.,	2.2 μ F/50V	
C108	21E04638S03	CER.,	100pF		C203	21E04638S10	CER.,	1000pF	
C109	21E04734S10	CER.,	100pF		C204	21E04638S10	CER.,	1000pF	
C110	21E04734S10	CER.,	100pF		C205	21E04734S08	CER.,	220pF	
C111	08E04735S05	MYL.,	0.01 μ F		C206	21E04734S08	CER.,	220pF	
C112	08E04735S05	MYL.,	0.01 μ F		C207	21E05504S01	CER.,	0.047 μ F	
C113	23E04754S04	ELY.,	22 μ F/16V		C208	21E05504S01	CER.,	0.047 μ F	
C114	23E04754S04	ELY.,	22 μ F/16V		C209	08E04735S09	MYL.,	0.022 μ F	
C115	23E04754S02	ELY.,	220 μ F/16V		C210	08E04735S09	MYL.,	0.022 μ F	
C116	23E04754S02	ELY.,	220 μ F/16V		C211	08E04735S09	MYL.,	0.022 μ F	
C117	23E04754S02	ELY.,	220 μ F/16V		C212	08E04735S09	MYL.,	0.022 μ F	
C118	21E05504S02	CER.,	0.01 μ F		C213	21E04638S09	CER.,	430pF	
C119	23E04754S01	ELY.,	10 μ F/16V		C214	21E04638S09	CER.,	430pF	
C120	23E04754S01	ELY.,	10 μ F/16V		C215	08E04735S05	MYL.,	0.01 μ F	
C121	08E04735S06	MYL.,	0.015 μ F		C216	08E04735S05	MYL.,	0.01 μ F	
C122	08E04735S06	MYL.,	0.015 μ F		C217	23E04754S01	ELY.,	10 μ F/16V	
C123	23E04754S01	ELY.,	47 μ F/16V		C218	21E04734S01	CER.,	10pF	
C125	21E04734S11	CER.,	820pF		C219	08E05505S01	PP.,	2200pF	
C126	21E04734S11	CER.,	820pF		C220	08E05505S02	PP.,	1500pF	
C131	08E04735S16	MYL.,	4700pF		C221	23E04754S03	ELY.,	100 μ F/16V	
C132	08E04735S16	MYL.,	4700pF		C222	08E04735S05	MYL.,	0.01 μ F	
C133	23E04635S04	ELY.,	0.47 μ F/50V		C223	08E04735S12	MYL.,	6800pF	
C134	23E04635S04	ELY.,	0.47 μ F/50V		C224	08E04735S05	MYL.,	0.01 μ F	
C135	08E05500S01	MYL.,	0.15 μ F		C227	21E04734S09	CER.,	1000pF	
C136	08E05500S01	MYL.,	0.15 μ F		C228	21E04734S09	CER.,	1000pF	
C137	08E04735S06	MYL.,	0.015 μ F		C229	23E04754S01	ELY.,	10 μ F/16V	
C138	08E04735S06	MYL.,	0.015 μ F		C230	23E04754S01	ELY.,	10 μ F/16V	
C139	23E04635S05	ELY.,	0.22 μ F/50V		C231	08E05500S06	MYL.,	0.082 μ F	
C140	23E04635S05	ELY.,	0.22 μ F/50V		C232	08E05500S06	MYL.,	0.082 μ F	
C141	08E05500S03	MYL.,	0.068 μ F		C233	08E04735S15	MYL.,	1800pF	
C142	08E05500S03	MYL.,	0.068 μ F		C234	08E04735S15	MYL.,	1800pF	
C143	08E05500S05	MYL.,	0.047 μ F		C235	23E04754S01	ELY.,	10 μ F/16V	
C144	08E05500S05	MYL.,	0.047 μ F		C236	23E04754S01	ELY.,	10 μ F/16V	
C145	08E04735S12	MYL.,	6800pF		C237	08E04735S08	MYL.,	5600pF	
C146	08E04735S12	MYL.,	6800pF		C238	08E04735S08	MYL.,	5600pF	
C147	08E04735S05	MYL.,	0.01 μ F		C241	08E04735S13	MYL.,	3300pF	
C148	08E04735S05	MYL.,	0.01 μ F		C242	08E04735S13	MYL.,	3300pF	
C151	23E04754S01	ELY.,	10 μ F/16V		C243	08E04735S15	MYL.,	1800pF	
C152	23E04635S07	ELY.,	4.7 μ F/50V		C244	08E04735S15	MYL.,	1800pF	
					C245	08E04735S18	MYL.,	1500pF	
					C246	08E04735S18	MYL.,	1500pF	
					C247	08E04735S08	MYL.,	5600pF	
					C248	08E04735S08	MYL.,	5600pF	
					C249	23E04754S03	ELY.,	100 μ F/16V	

Symbol No.	Part No.	Description			Symbol No.	Part No.	Description		
C250	23E04754S01	ELY., 10 μ F/16V			VR102	18E05510S01	Semi-fixed 500B		
C251	23E04754S04	ELY., 22 μ F/16V			or	18E05511S01	Semi-fixed 500B		
C252	23E04754S04	ELY., 22 μ F/16V			VR203	18E05510S06	Semi-fixed 30kB		
C261	23E04635S07	ELY., 4.7 μ F/50V			or	18E05511S06	Semi-fixed 30kB		
C262	23E04635S07	ELY., 4.7 μ F/50V			VR204	18E05510S06	Semi-fixed 30kB		
					or	18E05511S06	Semi-fixed 30kB		
C271	23E04635S03	ELY., 1 μ F/50V			VR205	18E05510S02	Semi-fixed 5kB		
C272	23E04635S03	ELY., 1 μ F/50V			or	18E05511S02	Semi-fixed 5kB		
C277	21E04734S05	CER., 560pF			VR206	18E05510S02	Semi-fixed 5kB		
C278	21E04734S05	CER., 560pF			or	18E05511S02	Semi-fixed 5kB		
C279	21E04631S01	CER., 0.01 μ F			VR207	18E05510S02	Semi-fixed 5kB		
					or	18E05511S02	Semi-fixed 5kB		
C301	23E04635S08	ELY., 2.2 μ F/50V			VR208	18E05510S02	Semi-fixed 5kB		
C302	23E04635S08	ELY., 2.2 μ F/50V			or	18E05511S02	Semi-fixed 5kB		
C303	23E04635S08	ELY., 2.2 μ F/50V			VR209	18E05510S03	Semi-fixed 50kB		
C304	23E04635S08	ELY., 2.2 μ F/50V			or	18E05511S03	Semi-fixed 50kB		
C305	23E04754S05	ELY., 47 μ F/16V			VR210	18E05510S03	Semi-fixed 50kB		
C306	23E06052S03	ELY., 100 μ F/10V			or	18E05511S03	Semi-fixed 50kB		
C415	23E04754S01	ELY., 10 μ F/16V			VR845	18E05929S01	Semi-fixed 2kB		
C416	23E04754S01	ELY., 10 μ F/16V			or	18E05930S01	Semi-fixed 2kB		
C501	21E04736S06	CER., 30pF							
C502	21E04736S06	CER., 30pF							
C503	23E04754S03	ELY., 100 μ F/16V							
C506	08E04735S11	MYL., 2200pF							
C507	23E04754S08	ELY., 33 μ F/16V							
C508	23E04731S02	ELY., 10 μ F/35V							
C510	23E04754S05	ELY., 47 μ F/16V							
C511	23E04754S05	ELY., 47 μ F/16V							
C601	21E05506S01	CER., 0.047 μ F							
C603	23E04636S03	ELY., 3300 μ F/25V							
C604	23E04754S06	ELY., 470 μ F/16V							
C605	23E04754S07	ELY., 4700 μ F/16V							
C606	23E06052S03	ELY., 100 μ F/10V							
C607	21E04631S04	CER., 0.047 μ F							
C608	23E04635S03	ELY., 1 μ F/50V							
Resistors					Power SW P. C. Board				
R131	06E05508S03	C.F., 1K ohm 1/2W			Capacitor/Switch				
R181	06E05508S04	C.F., 100 ohm 1/2W			C895	08E04663S01	CAP., Line, 0.01 μ F/400V		
R224	06E05508S05	C.F., 30 ohm 1/2W			SW895	40E04667S01	Switch, Push (Power)		
R246	06E05508S02	C.F., 220 ohm 1/2W							
R309	08E05508S08	C.F., 180 ohm 1/2W							
R545	06E05508S03	C.F., 1K ohm 1/2W			Meter P. C. Board				
R601	06E05509S01	Fuse 2.2 ohm 1/4W			IC				
R602	06E05546S01	Fuse 2.2 ohm 1/2W			IC815	51E05538S01	TA7666P		
R603	06E05509S03	Fuse 13 ohm 1/4W			or	51E05547S01	KIA7666P		
VR101	18E05510S01	Semi-fixed 500B							
or	18E05511S01	Semi-fixed 500B							

Symbol No.	Part No.	Description			Symbol No.	Part No.	Description		
Transistors					Capacitors				
Q815 or Q816 or	48E05542S01 48E04784S04 48E05542S01 48E04784S04	2SC945 KTC1815 2SC945 KTC1815			C815 C816 C817 C818 C819	23E04635S10 23E04635S10 23E04635S04 23E04635S04 23E04635S10	ELY., 10 μ F/16V ELY., 10 μ F/16V ELY., 0.47 μ F/50V ELY., 0.47 μ F/50V ELY., 10 μ F/16V		
LED's					Resistors				
LD815 LD816 LD817 LD818 LD819 LD820 LD821 LD822 LD823 LD824 LD825 LD826 LD871 LD872 LD873 LD874 LD875	48E05928S01 48E05928S01 48E05928S01 48E05928S01 48E08062S01 48E08062S01 48E08062S01 48E08062S01 48E08062S01 48E08062S01 48E08062S01 48E08062S01 48E05512S01 48E05513S01 48E05514S01 48E05513S01 48E05513S01	SLR-58DC3F (Orange) SLR-56DC3F (Orange) SLR-56DC3F (Orange) SLR-56DC3F (Orange) SLR-56MC3F (Green) SLR-56MC3F (Green) SLR-56MC3F (Green) SLR-56MC3F (Green) SLR-56MC3F (Green) SLR-56MC3F (Green) SLR-40MG3F (Green) SLR-40DU3F (Orange) SLR-40VR3F (Red) SLR-40DU3F (Orange) SLR-40DU3F (Orange)			VR815 or VR816 or	18E05510S04 18E05511S04 18E05510S04 18E05511S04	Semi-fixed 20k Ω Semi-fixed 20k Ω Semi-fixed 20k Ω Semi-fixed 20k Ω		
Dolby SW P. C. Board					Control P. C. Board				
Switches					Switches				
					SW855 or SW856 or	40E05516S01 40E05516S02 40E05516S01 40E05516S02	Switch, Push (Dolby ON/OFF) Switch, Push Switch, Push (Dolby B/C) Switch, Push		
					SW860 SW861 SW862 SW864 SW865 SW866	40E08063S01 40E08063S01 40E08063S01 40E08063S01 40E08063S01 40E08063S01	Switch, Key (PLAY) Switch, Key (PAUSE) Switch, Key (REC) Switch, Key (REW) Switch, Key (STOP) Switch, Key (FF)		

Symbol No.	Part No.	Description		
Headphone P. C. Board				
IC				
IC801	51E05540S01	NJM4556S		
Transistors				
Q801 Q802	48E05541S01 48E05541S01	2SD1012 (D) 2SD1012 (D)		
Jack				
JK801	09E05518S01	Jack 6.3		
Capacitors				
C801	23E04754S03	ELY., 100 μ F/16V		
C802	23E04754S03	ELY., 100 μ F/16V		
C803	23E04635S08	ELY., 2.2 μ F/50V		
C804	23E04635S08	ELY., 2.2 μ F/50V		
C805	21E04638S03	CER., 100pF		
C806	21E04638S03	CER., 100pF		
C807	23E04635S03	ELY., 1 μ F/50V		
C808	23E04635S03	ELY., 1 μ F/50V		
C809	23E04754S05	ELY., 47 μ F/16V		
Resistors				
VR801 or VR802 or	18E05520S01 18E05520S02 18E08065S01 18E08065S02	Rotary VR 50KB Rotary VR 50KB Rotary VR 50KB Rotary VR 50KB		

Symbol No.	Part No.	Description		
Miscellaneous				
IC701	51E05436S01	Hall IC LB9050TN for Mechanism		
M701	59E08255S01	Motor		
P801	28E04687S01	AC power Cord		
HD701	88E08253S01	E Head Deck		
HD702	88E08254S01	R/P Head, Deck		
S701	40E05434S01	Switch, Leaf, (PLAY) for Mechanism		
S703	40E05435S01	Switch, Leaf, (Tape Detect) for Mechanism		
S704	40E05433S01	Switch, Leaf, (FWD REC Safety) for Mechanism		
S705	40E05433S01	Switch, Leaf (Metal Select) for Mechanism		
S706	40E05435S01	Switch, Leaf, (FF/REWIND) for Mechanism		
S707	40E05433S01	Switch, Leaf, (CrO2 Select) for Mechanism		
SD701	01E05399S01	Solenoid 1 for Mechanism		
SD702	01E05399S01	Solenoid 2 for Mechanism		
T801	25E05931S01	TRANS., Power E154 120/220/240V		
SW800	40E08064S01	Switch, Voltage Selector		

Packing Assembly Parts List

Symbol No.	Part No.	Description	Symbol No.	Part No.	Description
101	56E08233S01	Carton, Packing (IND)	106	56E08308S01	PKG. Front Flame
102	56E05497S01	Tray, Packing (L, R)			
103	56E05498S01	Bag, High Polyester			
104	68P96552F73	Owner's Manual			
105	28E04778S02	Cord, Patch			

Packing Method View

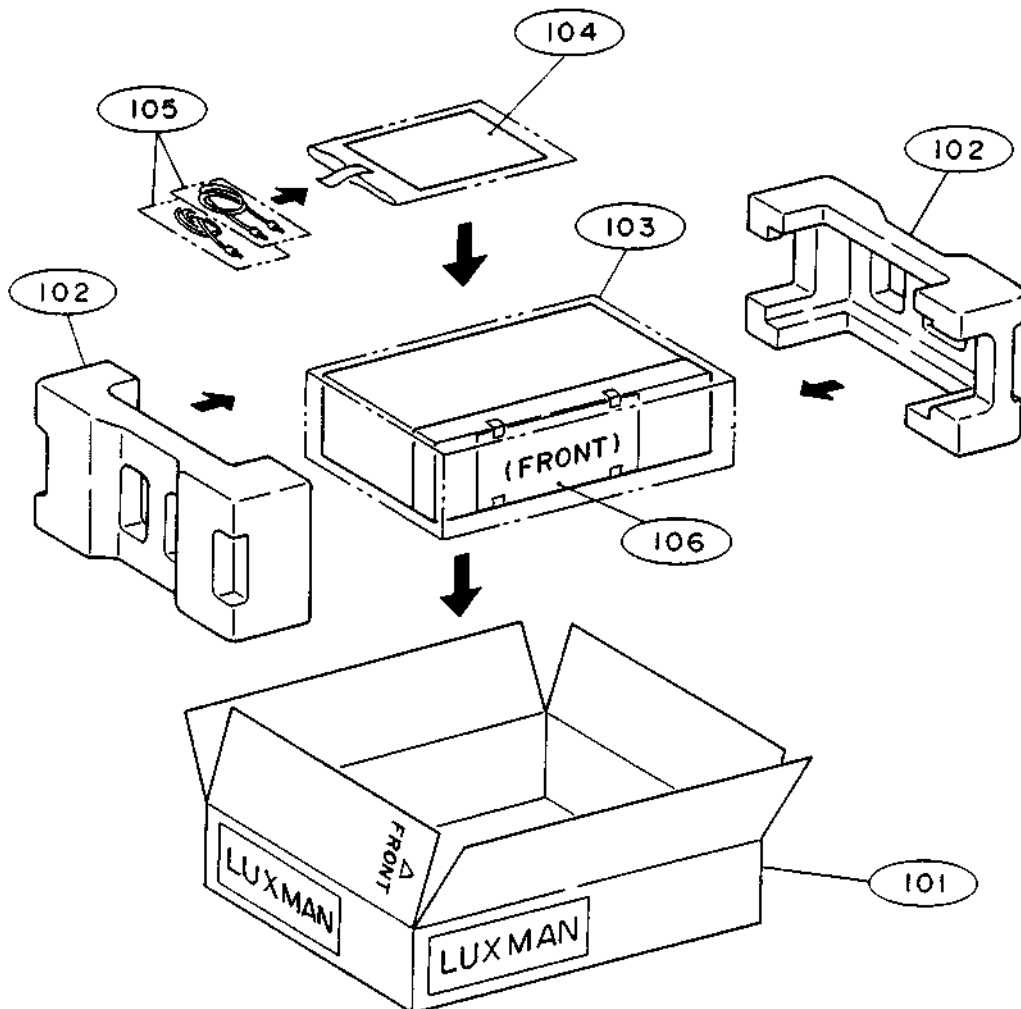

Cabinet Assembly Parts List

Note: The parts without part number are not supplied.

Symbol No.	Index	Part No.	Description			Symbol No.	Index	Part No.	Description		
1	2-A	15E08074S01	Cabinet, Top			36	4-E	03E05066S03	Screw, Taptime (M2 x 8)		
2		03E04701S04	Screw, Taptime (M3 x 10)			37	3-E	36E04672S01	Knob, Dolby		
3		03E04702S09	Screw, Taptime (M3 x 6)			38	3-F	03E04701S04	Screw, Taptime (M3 x 10)		
4	5-A	64E08256S01	Plate, Door			39	2-D	72E05466S01	Counter		
5	5-B	15E08071S01	Assy., Door			40	2-C	43E07210S01	Collar		
6	4-B	64E08257S01	Window, Door			41	2-D	42E05491S01	Belt		
7		03E05066S02	Screw, Taptime (M2 x 5)			42	1-D	81E08066S01	Assy., Tape, Mechanism		
8	4-A	04E05465S01	Washer, (M2)			43	1-D	07E08262S01	Holder		
9		41E05448S01	Spring, Leaf			44	5-E	14E08306S01	Sheet, Insulation		
10	4-B	07E05451S01	Cover			45	2-E	07E05480S01	Holder, Base		
11	4-C	03E04701S03	Screw, Taptime (M2.6 x 8)			46	2-E	41E05481S01	Spring, Coil		
12	3-B	64E08068S01	Assy., Panel Front			47	2-E	07E05483S01	Lever, Door Look		
13	3-B	36E04673S01	Knob, Power			48	2-F	46E05487S01	Stud		
14	4-C	36E05461S01	Knob, Level			49	2-F	03E05490S01	Screw (M2 x 4)		
15	5-C	36E04677S01	Knob, Rec Level			50	2-E	07E05485S01	Lever, Eject		
16		03E04701S01	Screw, Taptime (M3 x 8)			51	2-F	43E05489S01	Spacer		
17	3-C	64E05445S01	Mirror, Cassette			52	2-E	41E05493S01	Spring, Torsion		
18	3-C	64E08258S01	Plate, Indication			53	3-E	04E05494S01	E-ring		
19	4-D	64E08259S01	Window			54	3-E	03E05490S03	Screw (M2 x 12)		
20	4-D	75E08260S01	Cushion			● 55	1-F	15E08263S01	Panel, Back		
21	4-D	05E04709S02	Rivet, Nylon			○ 55	1-F	15E08264S01	Panel, Back		
22		03E04775S02	Screw, Taptime (M3 x 6)			56	1-G	43E04688S01	Bushing, Cord		
23	3-D	01E08072S01	Assy., Damper			57	3-F	02E05471S01	Nut, Flange		
24		04E05467S01	Washer, (M2.6)			58	3-F	29E04693S01	Lug		
25		03E04701S06	Screw, Taptime (M2.6 x 6)			59	3-F	29E08100S01	Terminal, Pin		
26	3-D	41E05452S01	Spring, Torsion			60	3-F	84E08281S01	PCB 31		
27	3-D	07E05455S01	Holder, Door			61	4-G	75E05472S01	Cution		
28	2-D	07E05486S01	Slider			62		75E04521S01	Foot, Front		
29	2-D	43E05488S01	Spacer			63		03E04702S06	Screw, Taptime (M4 x 10)		
30	2-D	03E05490S02	Screw, (M2 x 10)			64		75E04678S01	Foot, Back		
31	3-E	36E05468S02	Knob, Eject			65	2-D	07E08307S01	Shield, Cover		
32	3-E	07E08261S01	Holder			66	4-F	03E08004S01	Screw, Taptime (M3 x 6)		
33	3-E	03E05066S04	Screw, Taptime (M2.6 x 6)			67	4-F	29E04693S01	Lug		
34	3-D	36E08070S01	Knob, Play/Pause								
35	3-E	36E06178S01	Knob, Rew/Stop/FF/Rec								

Note ●: For West Germany model only (AD)

○: For General Foreign model only (EK)

Others Common

Exploded View (Cabinet)

1

2

3

4

5

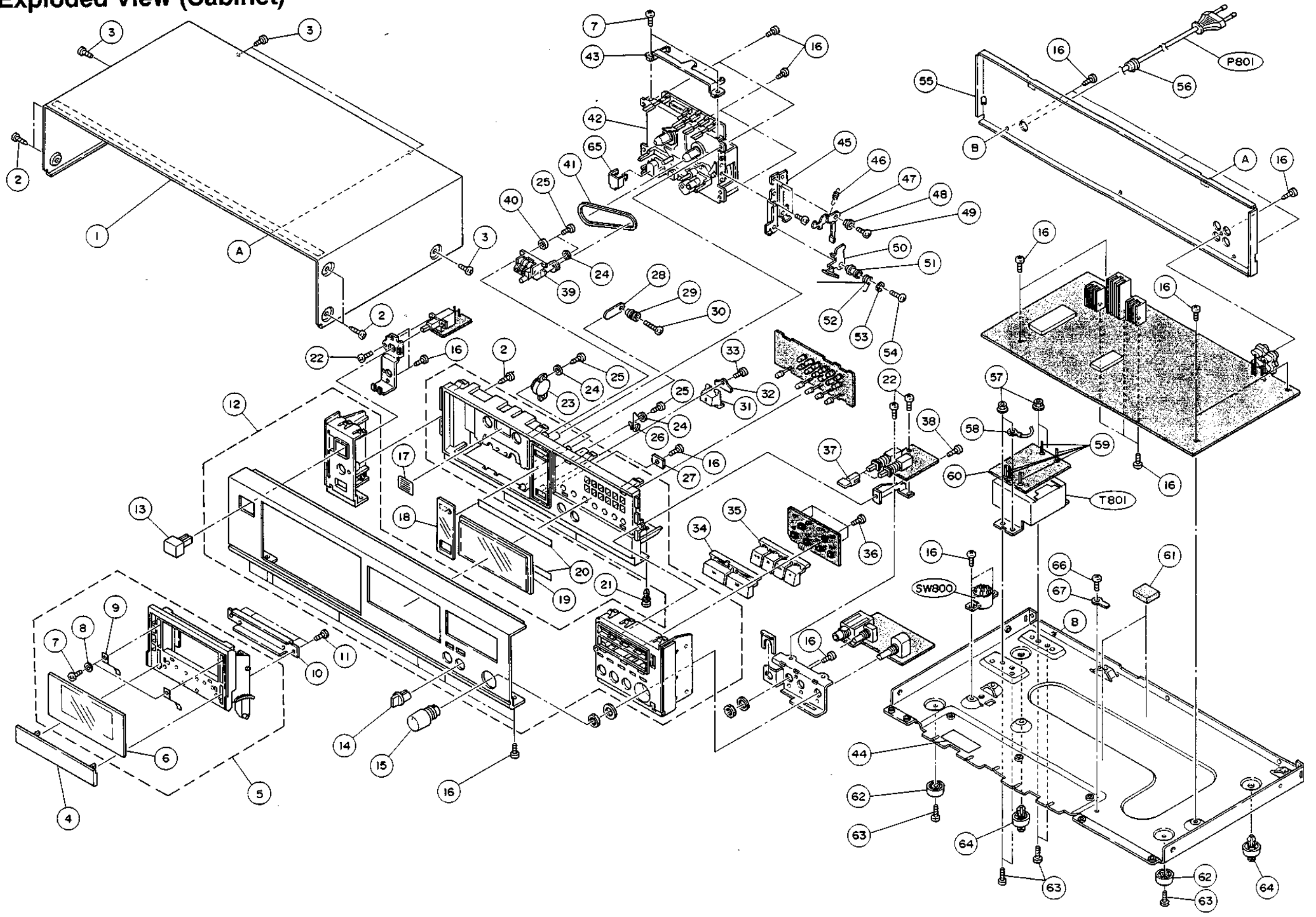

A

B - 31 -

C

D

E

F - 32 -

G

H

Exploded View (Cassette Deck)

1

2

3

4

5

A

B

C

D

E

F

G

H

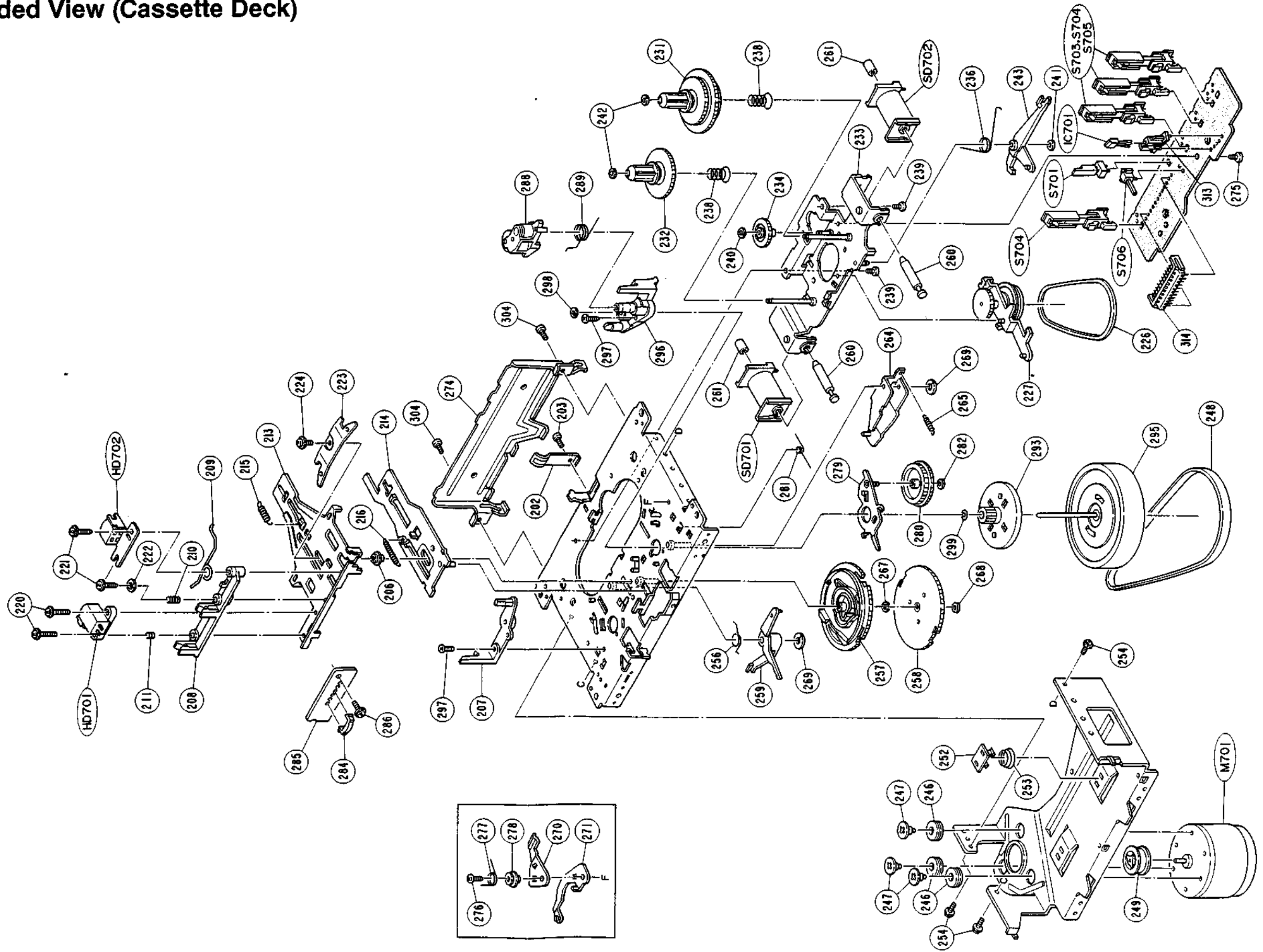

Cassette Deck Assembly Parts List

Note: The parts without part number are not supplied.

Symbol No.	Index	Part No.	Description	Symbol No.	Index	Part No.	Description
202	3-D	41E05346S01	Spring, Pack	253	5-F	41E05387S01	Spring, Damper
203	3-D	03E05347S01	Screw, Tapping, (M2 x 3)	254		03E05388S01	Screw, Tams (M2 x 4)
206	4-C	43E08234S01	Collar, Panel (A)	256	4-E	41E05389S01	Spring, M
207	4-D	45E08238S01	Guide, Tape				Trigger
208	4-B	01E08239S01	Head, Base	257	4-F	44E05390S01	M Gear
209	3-B	41E08242S01	Spring, Pinch Roller	258	4-F	44E05391S01	Gear, RF Cam
210	3-B	41E08243S01	Spring, Azimuth	259	4-E	45E05392S01	Arm, M Trigger
211	4-B	41E08244S01	Spring, EH	260		47E05393S01	Plunger
213	3-C	15E08248S01	Head, Panel (A)	261		43E05394S01	Holder, Plunger
214	3-C	15E05357S01	Head, Panel (B)	264	2-F	01E05397S01	Ass'y, P Kick Lever
215	3-B	41E08245S01	Spring, RC	265	3-F	41E05398S01	Spring, PK Lever
216	3-C	41E08246S01	Spring, Panel	267	4-F	04E05400S01	E Ring ø2.0
220	4-A	03E08236S01	Screw, (M2 x 11)	268	4-F	04E05401S01	HL Washer, (M1.55)
221	3-B	03E08237S01	Screw, (M2 x 9.5)	269		04E05378S01	HL Washer, (M2.1)
222	3-B	04E08249S01	Washer, BS (M2.1)	270	5-D	07E05441S01	E Stopper A (F)
223	3-C	41E08247S01	Spring, Plate	271	5-D	07E05442S01	E Stopper B (F)
224	3-C	03E05366S01	Screw, Tapping (M2 x 5)	274	3-C	15E05405S01	Protector, SW
226	2-G	42E05368S01	RF, Belt	275	2-G	03E05406S01	Screw, (M2 x 5)
227	3-F	01E08240S01	Ass'y, RF Clutch	276	5-D	03E08235S01	Screw, (M2 x 5)
231	1-E	01E05370S01	Ass'y, T Reel (F)	277	5-D	41E05408S01	Spring, E Stopper
232	2-E	01E08241S01	Ass'y, S Reel	278	5-D	43E05409S01	Collar, E Stopper
233	2-F	01E05372S01	Ass'y, Reel Base	279	3-E	01E05410S01	Ass'y, T Gear Arm
234	2-E	44E05373S01	Gear, FF	280	3-F	44E08251S01	T Gear
236	1-F	41E05374S01	Spring, FR Trigger Arm	281	3-E	41E05412S01	Spring, TG Arm
238		41E05375S01	Spring, (R) B.T	282	3-F	04E05377S01	P Washer, (M1.2)
239	2-F	03E05376S01	Screw, Tapping (M2 x 4)	284	4-C	43E05355S01	Wire, Clamp
240	2-E	04E05377S01	P Washer, (M1.2)	285	4-C	84E05439S01	Relay, Board
241	1-G	04E08250S01	P Washer, (M2.1)	286	4-C	03E05365S01	Screw, (M2 x 5)
242	1-D	04E05379S01	HL Washer, (M1.4)	288	2-D	01E05416S01	Ass'y, Pinch Roller Arm (F)
243	1-F	45E05380S01	Arm, RF Trigger	289	2-D	41E05417S01	Spring, P Arm
246	5-F	75E05381S01	Motor, Rubber	293	3-F	44E05420S01	Gear, FL
247	5-F	03E05382S01	Screw, Motor Collar	295	3-G	49E05422S01	Ass'y Flywheel (F)
248	3-G	42E08252S01	Belt, Main	296	3-D	01E05423S01	Ass'y FL Metal, (F)
249	5-G	49E05384S01	Pulley, Motor	297		03E05424S01	Screw, (M2 x 6)
252	4-F	07E05386S01	FL Patch, Plate	298	2-D	04E05425S01	Washer (M2.1) (Nylon)
				299	3-F	04E08282S01	HL Washer (M2.3)

Symbol No.	Index	Part No.	Description			Symbol No.	Index	Part No.	Description		
304		03E05376S01	Screw, Tapping (M2 x 4)								
313	2-G	48E05437S01	IC, Protector								
314	2-G	09E05443S01	Connector, TXL- P 12PM1								

Semi-Conductor Lead Identifications

μ PC1330HA : IC101

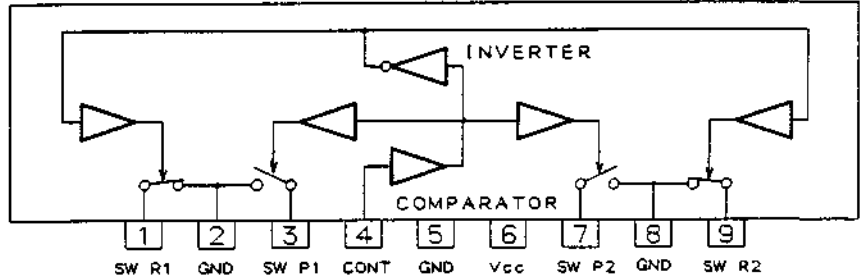
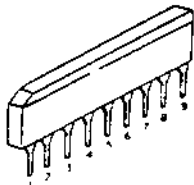

NJM2068 : IC102

NJM4558S : IC104

NJM4556S : IC801

TA75558S : IC203

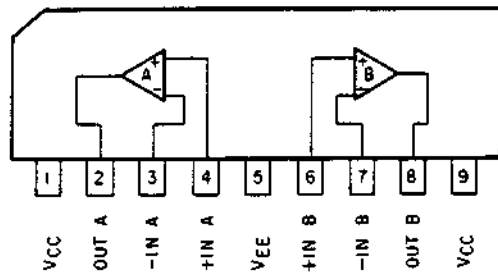
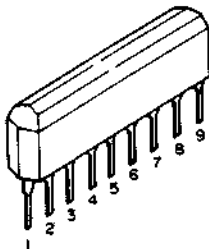

CX20187 : IC103

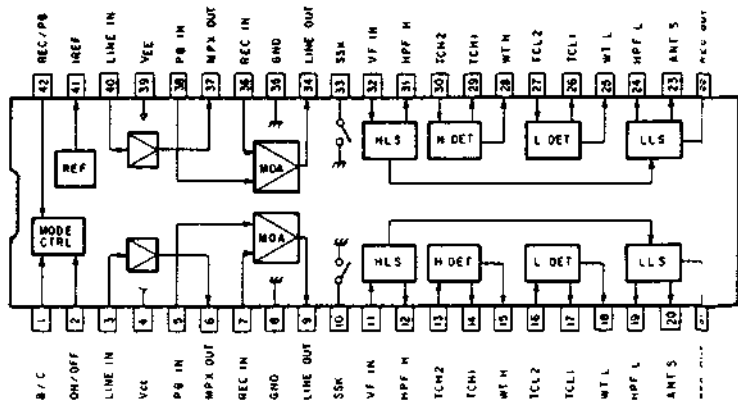
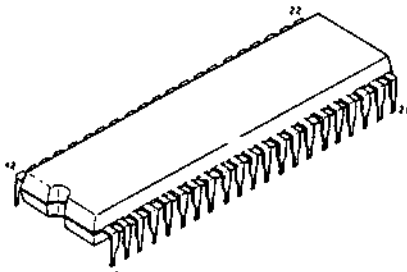

μ PC1297CA : IC202

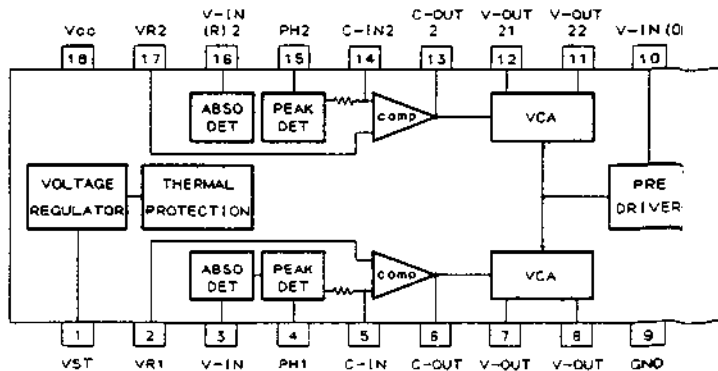
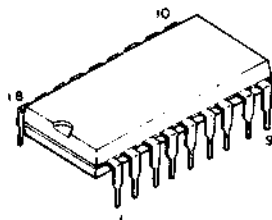

NJU4066B : IC205

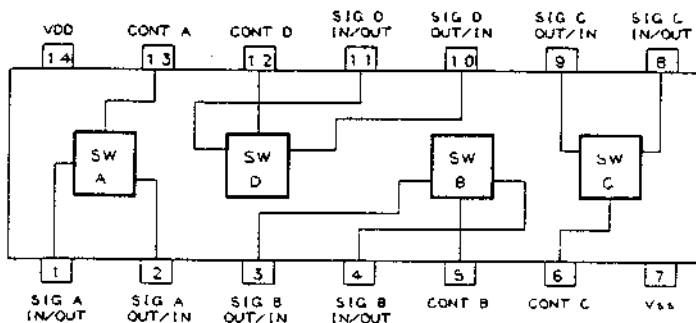
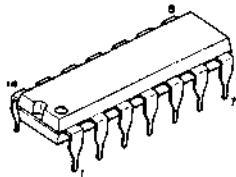

TCV1008 : IC501

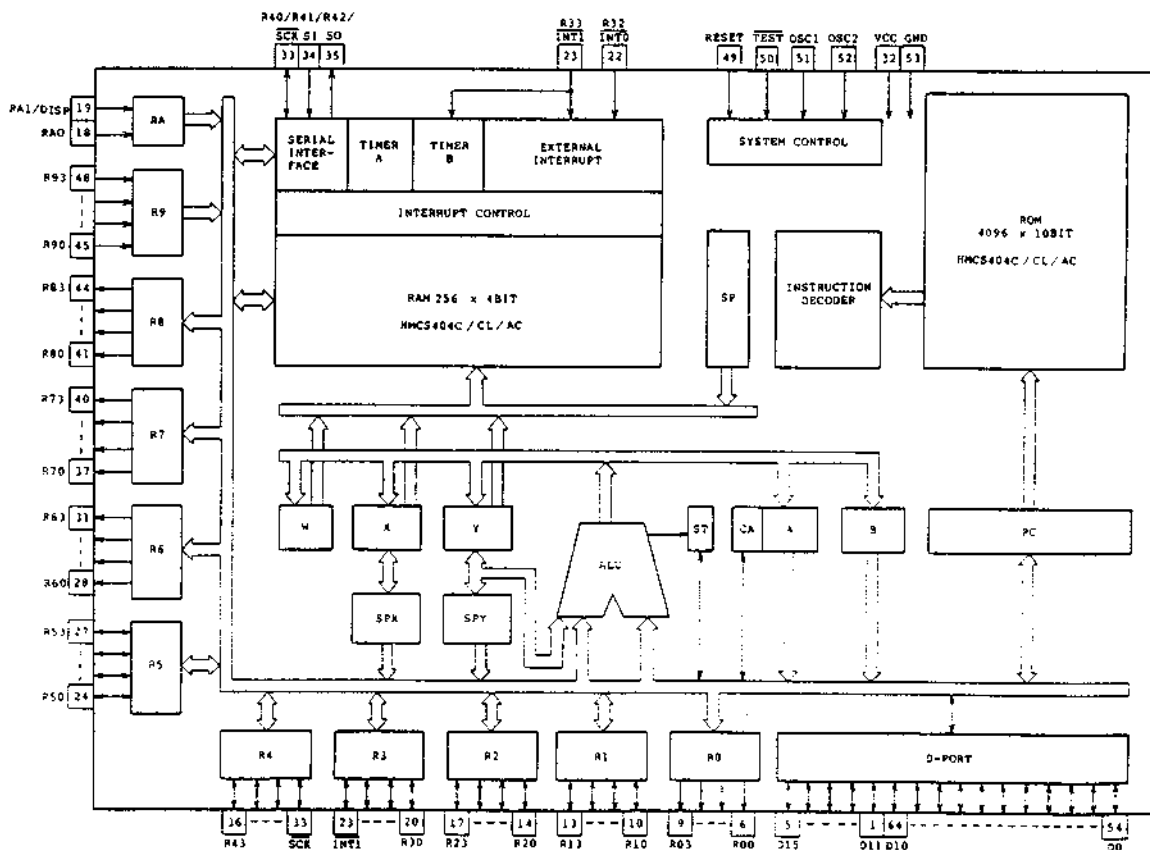
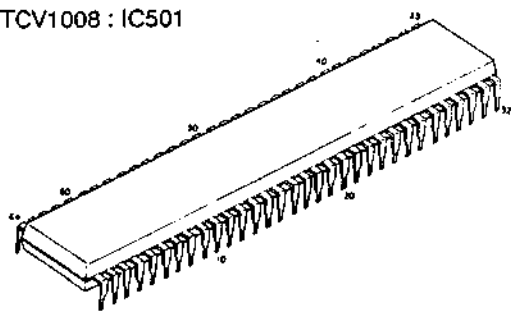

PST523E : IC502

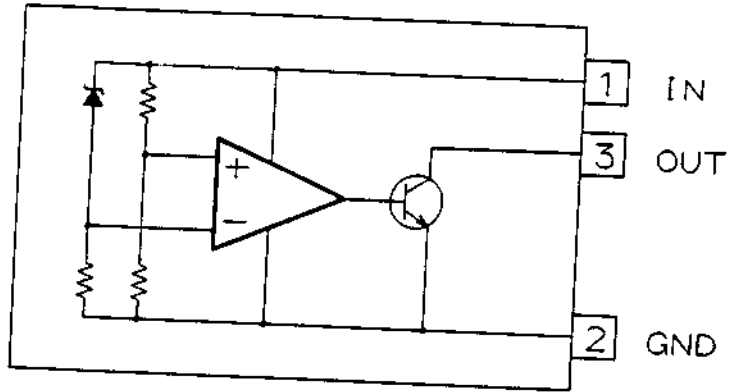

MC7812CT : IC602
 MC78M12CT : IC601
 MC78M06CT : IC603

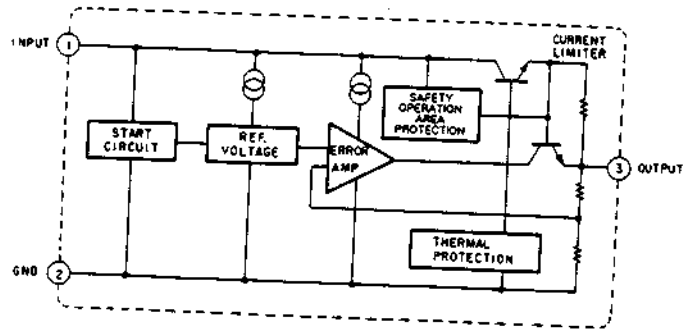
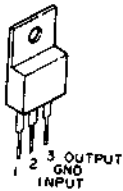

TA7666P : IC815

