

SERVICE MANUAL

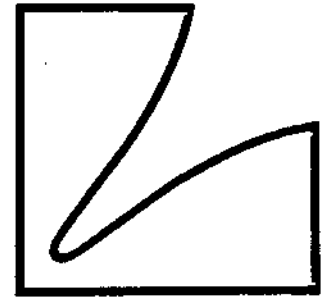

LUXMAN STEREO CASSETTE DECK

K-12

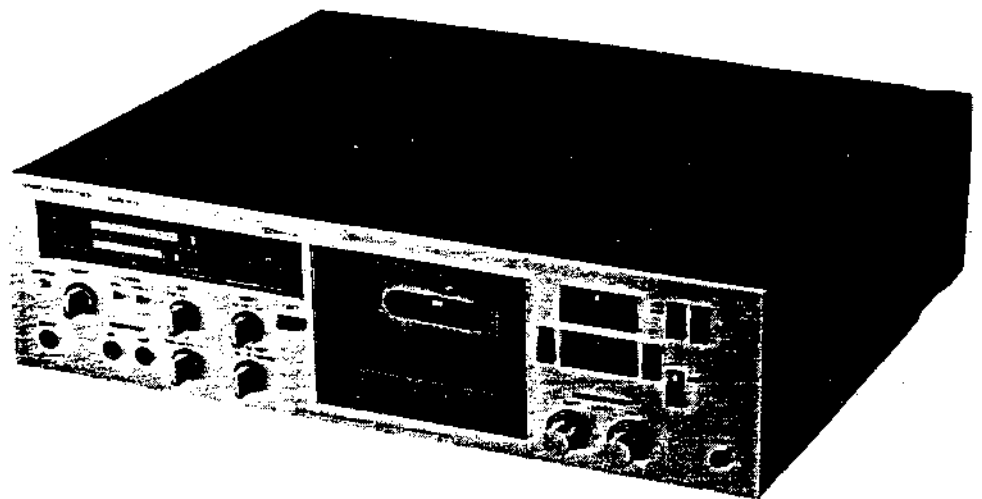

NO.	ITEMS	TAPE REQUIRED	SELECTOR POSITION		INPUT SIGNAL	ALIGNMENT PROCEDURE	LIMITED SPEC	REMARKS
			EQ SW	BIAS SW				
						(2) Set the BIAS sw to "CrO ₂ ", and preset the BIAS current to 400µA. Trimmer Pot for CrO ₂ BIAS Adj. -- Lch VR201a Rch VR203b (3) Set the BIAS sw to "EX", and preset the BIAS current to 650µA. Trimmer Pot for EX BIAS Adj. -- Lch VR203a Rch VR201b	CrO ₂ 400µA (=4mV, at 10 ohms) EX 650µA (= 6.5mV, at 10 ohms)	"REC" mode
14.	Peaking Adjust at REC. EQ. AMP		NORMAL	NORMAL	18kHz 100mV (-18dBm)	To keep out the action of BIAS OSC, insert a tip of paper in the leaf switch connected in series with the power supply to the oscillator. (The leaf Sw is placed near the main solenoid.) Then put the deck into the "REC" mode. (1) Set the Equalizer Sw to the "NORMAL" position, and apply 18kHz 100mV signal to LINE INPUT. Adjust the peaking coil for NORMAL to obtain the maximum output at the 10-ohm resistor of the R/P head. Peaking Coil for NORMAL --- Lch L105a Rch L105b	Adjust peaking for NORMAL mode by use of 18kHz signal	Output should be measured across the 10-ohm resistor. "REC" mode
			CrO ₂		20kHz	(2) Set the Equalizer Sw to the "CrO ₂ " position and apply 20kHz 100mV signal to LINE INPUT. Adjust the peaking coil for CrO ₂ to obtain the maximum reading on the VTVM. Peaking Coil for CrO ₂ --- Lch L104a Rch L104b	Adjust peaking for CrO ₂ mode by use of 20kHz signal	
			EX		21kHz	(3) Set the Equalizer Sw to the "EX" position and apply 21kHz 100mV signal to LINE INPUT. Adjust the peaking coil for EX to obtain the maximum reading on the VTVM. Peaking Coil for EX --- Lch L106a Rch L106b	Adjust peaking for EX mode by use of 21kHz signal	
					400Hz, 100mV [±] 3dB(-18dBm-3dB) Output level at LINE OUT, monitoring source, should be 580mV	Each peaking level at the respective mode, NORMAL CrO ₂ and EX should be approximately 20dBm at 18kHz, 20kHz, 21kHz, compared with that of 1kHz (4) Do not forget to remove a piece of paper put on the leaf switch. Adjust the REC Gain trimmer pot to obtain LINE OUT output level of 580mV(-2.5dBm) when the AC-221 tape 400Hz signal is recorded and played-back. NORMAL REC Gain Adjustment	-2.5 [±] 0.5 dBm	Input level at LINE IN

NO.	ITEMS	TAPE	SELECTOR POSITION		INPUT SIGNAL	ALIGNMENT PROCEDURE	LIMITED	REMARKS
		REQUIRED	EQ SW	BIAS SW				
8.	P/B Frequency Response Adjust. (normal)	MIT-216	NORMAL	NORMAL	no signal	Playback MIT-216 standard frequency response signal (315Hz), and make note of the output level. Then playback the frequency adjustment signal from 31.5Hz to 14kHz. At this time, the playback output level at each frequency should be within $\pm 2\text{dBm}$ when the standard output level is regarded as zero (0).	Should be within $\pm 2\text{dBm}$, referencing 315Hz signal as 0.	Dolby off
9.	P/B Frequency Response Adjust. (CrO ₂ , EX)	MIT-316	CrO ₂ EX	NORMAL		Set EQ Selector to "CrO ₂ " (or "EX") position. Playback standard frequency signal 315Hz of MIT-316 (3180uS+70uS), and make note of the output level. Then playback frequency alignment signal from 31.5Hz to 14kHz. At this time, the playback output level at each frequency should be within $\pm 2\text{dBm}$ when the standard output level is regarded as zero (0).	Should be within $\pm 2\text{dBm}$, referencing 315Hz signal as 0 (zero).	Dolby off
10.	P/B Signal-to-Noise Adjust.		NORMAL	NORMAL		Put the deck to "PLAY" mode without loading cassette hub, and check noise level at LINE OUT Jacks. Noise Level ----- no more than -50dBm(RMS) Likewise, check that at the respective mode: "CrO ₂ ", "EX", "Dolby ON", "MPX.FILTER" and "PAUSE".	Should be no more than -50dBm at each mode	
11.	Frequency Adjust. of BIAS OSC.		CrO ₂	CrO ₂		Connect counter to the current output terminals of erasing head [terminal No. 19 (+), No. 18 (-)]. Set the BIAS Sw. to "CrO ₂ " mode. Turn the BIAS OSC coil to obtain 105kHz oscillation frequency. BIAS OSC Coil --- L-201 Also check if oscillation frequency at each "NORMAL" and "EX" position is 105kHz \pm 5kHz.	Bias OSC frequency: 105kHz \pm 5kHz at CrO ₂ & EX	"REC" mode
12.	Bias Trap Adjust. at REC EQ AMP.		EX	EX		Connect VTVM before trap coil at REC EQ AMP for both L and R channels, and adjust trap coil to obtain minimum reading of VTVM. Trap Coil --- L-ch L-103a --- R-ch L-103b At this time, the VTVM indication should be no more than +20dBm.	VTVM reading should be no more than +20dBm.	"REC" mode
13.	Bias Current Adj.		NORMAL	NORMAL CrO ₂ EX		Connect VTVM across the 10-ohm resistor of the record head. L-ch Terminal No. 42 ----- (+) Terminal No. GND ----- (-) R-ch Terminal No. 48 ----- (+) Terminal No. GND ----- (-) (1) Set the BIAS sw to "NORMAL", and pre-set the current-flow through the 10-ohm resistor to 300uA. Trimmer Pot for NORMAL BIAS ADJ. -- Lch VR202a Rch VR202b	NORMAL 300uA (=3mV, at 10 ohms)	"REC" mode

NO.	ITEMS	TAPE REQUIRED	SELECTOR POSITION		INPUT SIGNAL	ALIGNMENT PROCEDURE	LIMITED SPEC	REMARKS
			EQ SW	BIAS SW				
						<p>(2) Set the BIAS sw to "CrO₂", and preset the BIAS current to 400µA. Trimmer Pot for CrO₂ BIAS Adj. -- Lch VR201a Rch VR203b</p> <p>(3) Set the BIAS sw to "EX", and preset the BIAS current to 650µA. Trimmer Pot for EX BIAS Adj. -- Lch VR203a Rch VR201b</p>	<p>CrO₂ 400µA (=4mV, at 10 ohms)</p> <p>EX 650µA (= 6.5mV, at 10 ohms)</p>	"REC" mode
14.	Peaking Adjust at REC. EQ. AMP		NORMAL	NORMAL	<p>18kHz 100mV (-18dBm)</p> <p>20kHz</p> <p>21kHz</p>	<p>To keep out the action of BIAS OSC, insert a tip of paper in the leaf switch connected in series with the power supply to the oscillator. (The leaf Sw is placed near the main solenoid.) Then put the deck into the "REC" mode.</p> <p>(1) Set the Equalizer Sw to the "NORMAL" position, and apply 18kHz 100mV signal to LINE INPUT. Adjust the peaking coil for NORMAL to obtain the maximum output at the 10-ohm resistor of the R/P head. Peaking Coil for NORMAL --- Lch L105a Rch L105b</p> <p>(2) Set the Equalizer Sw to the "CrO₂" position and apply 20kHz 100mV signal to LINE INPUT. Adjust the peaking coil for CrO₂ to obtain the maximum reading on the VTVM. Peaking Coil for CrO₂ --- Lch L104a Rch L104b</p> <p>(3) Set the Equalizer Sw to the "EX" position and apply 21kHz 100mV signal to LINE INPUT. Adjust the peaking coil for EX to obtain the maximum reading on the VTVM. Peaking Coil for EX --- Lch L106a Rch L106b</p> <p>Each peaking level at the respective mode, NORMAL CrO₂ and EX should be approximately 20dBm at 18kHz, 20kHz, 21kHz, compared with that of 1kHz</p> <p>(4) Do not forget to remove a piece of paper put on the leaf switch.</p>	<p>Adjust peaking for NORMAL mode by use of 18kHz signal</p> <p>Adjust peaking for CrO₂ mode by use of 20kHz signal</p> <p>Adjust peaking for EX mode by use of 21kHz signal</p>	<p>Output should be measured across the 10-ohm resistor. "REC" mode</p>
			CrO ₂		400Hz, 100µV [†] 3dB(-18dBm-3dB) Output level at LINE OUT, monitoring source, should be 580mV	<p>Adjust the REC Gain trimmer pot to obtain LINE OUT output level of 580mV(-2.5dBm) when the AC-221 tape 400Hz signal is recorded and played-back. NORMAL REC Gain Adjustment Lch VR110a Rch VR110b</p>	-2.5 ± 0.5 dBm	Input Level at LINE IN should be -18dB ± 3dB.

TAPE SELECTOR POSITION

No.	ITEMS	TAPE REQUIRED	SELECTOR EQ SW	POSITION BIAS SW	INPUT SIGNAL	ALIGNMENT PROCEDURE	LIMITED SPEC	REMARKS
16.	REC Gain Adjustment (CrO ₂)	AC-511	CrO ₂	CrO ₂	400Hz, 100mV ± 3dB (-18dBm ± 3dB) Output level at LINE OUT, monitoring source, should be 580mV	Adjust the REC Gain trimmer pot to obtain LINE OUT output level of 580mV (-2.5dBm) when the AC-511 tape 400Hz signal is recorded and played-back. CrO ₂ REC Gain Adjustment Lch VRI09a Rch VRI09b	-2.5 ± 0.5dBm	Input Level at LINE IN Should be -18dB ± 3dB
17.	REC Gain Adjust. (EX)	metal particle tape (AC-701)	EX	EX	Same as above.	Take the same alignment procedure described in step (16). EX REC Gain Adjustment Lch VRI11a Rch VRI11b		
18.	Bar Graph Display Check at "EX" mode		EX	EX		Check that the Bar Graph Indication at the "EX" mode is lower by 4dB compared to that of other modes. Note that this lower indication is realized only when both of the EQ sw and BIAS sw are in the "EX" position.	-4dB indication of the Bar Graph at the "EX" position of EQ sw & BIAS sw.	Input Level at LINE IN
19.	REC Frequency Response Adjust. (NORMAL)	AC-221	NORMAL	NORMAL	30-16kHz -20dB against standard input level	Record 30Hz - 16kHz signal (-20dB against the standard input level) from LINE INPUT, and playback. Check that the output level at each frequency is 0 - 3dB when 400Hz output is regarded as 0dB.	0 ± 3dB at each frequency	Input Level at LINE IN -38dBm ± 3dB
20.	REC Frequency Response Adjust. (CrO ₂)	AC-511	CrO ₂	CrO ₂	30-18kHz -20dB against standard input level	Record 30Hz - 18kHz signal (-20dB against the standard input level) from LINE INPUT, and playback. Check that the output level at each frequency is 0 - 3dB when 400Hz output is regarded as 0dB.	0 ± 3dB at each frequency	Input Level at LINE IN: -38dBm - 3dB
21.	REC Frequency Response Adj. (EX)	metal particle tape (AC-701)	EX	EX	30-20kHz -20dB against standard input level	Take the same alignment procedure described in (20) except the frequency range is from 30Hz to 20kHz.	0 ± 3dB at each frequency	Input Level at LINE IN: -38dBm - 3dB
22.	REC Frequency Response Adjust. in special case	AC-221 AC-511 metal particle tape (AC-701)	NORMAL CrO ₂ EX	NORMAL CrO ₂ EX	30 - 16kHz 30 - 18kHz 30 - 20kHz -20dB against standard input level	In case the frequency response does not meet the limited specification during the procedure steps (19)-(20), take the following procedure. a) When the Freq. response shows drop both at 4-8kHz (midrange) and over 15kHz (treble). See fig. 1 ----- Lower the bias current. (Turn the VR counter-clockwise direction.) When they are both increased. See fig. 2 ----- Increase the bias current. (Turn the VR clockwise.) b) When the frequency response drops only at treble range (over 10kHz). See fig. 3 ----- Shift peaking point downward by turning the peaking coil clockwise. When the response increases only in treble range. See fig. 4 ----- Shift peaking point upward by turning the peaking coil counter-clockwise.	RESPONSE RESPONSE RESPONSE RESPONSE fig. 1 2k 10k fig. 2 2k 10k 10k 10k	

NO.	ITEMS	TAPE REQUIRED	SELECTOR EQ SW	POSITION BIAS SW	INPUT SIGNAL	ALIGNMENT PROCEDURE	LIMITED SPEC	REMARKS
27	Record/Playback Output Level Check at Dolby ON and -OFF	AC-221	NORMAL	NORMAL	400Hz standard input signal level(0dB level on the Bar Graph)	Apply 400Hz standard input signal to LINE IN and record/play-back it. The output level at LINE OUT terminal should be 580mV \pm 1dB both for Dolby ON and OFF	580mV \pm 1dB	Dolby ON Dolby OFF
28.	Alignment of S/N at record/play-back	AC-221 AC-511 metal particle tape (AC-701)	NORMAL CrO ₂ EX	NORMAL CrO ₂ EX	no signal	Unload the LINE IN terminals, and make record/playback of the tape. The noise level at this time should be less than -47dBm(RMS). Check the noise level at CrO ₂ and EX position in the same manner. Both at the "Dolby ON" and "Dolby MPX Filter ON", the noise level should be less than -49dBm.	Record/Play-back noise level should be less than -47dBm(RMS). Record/Play-back noise level should be less than -49dBm(RMS).	
29.	Check of Erasure Capability	AC-221 AC-511 metal particle tape (AC-701)	NORMAL CrO ₂ EX	NORMAL CrO ₂ EX	1kHz +10dB against standard input level	Apply 1kHz -8dBm signal to LINE IN terminal, and record it. Next, make note of the output level. Then, disconnect the input signal and erase the recorded signal. Check the output level at the erased portion through 1kHz band-pass filter, and make note of the difference compared with that before erasing. Output Level before erasing ----- a1 (dBm) Output Level after erasing ----- a2 (dBm) Erasing Capability ----- A = a1-a2(dBm) Take the same procedure in the "CrO ₂ " and "EX" modes.	Erasing Capability A should be better than 70dBm	Use 1kHz band-pass filter
30.	Channel Sparation Check	AC-221 AC-511 metal particle tape (AC-701)	NORMAL CrO ₂ EX	NORMAL CrO ₂ EX	1kHz standard input level (0dB level at the Bar Graph)	Record 1kHz about -18dBm signal through Lch LINE IN, and play-back it. Then measure the record/playback output level of Rch via 1kHz band-pass filter. At the same time measure the record/playback output of Lch. Record/Playback Output Level (Lch) --- a1 (dBm) Record/Playback Output Level (Rch) --- a2 (dBm) Crosstalk from Lch to Rch: A = a1 - a2 (dB) Likewise apply signal to Rch to measure the crosstalk from Rch to Lch. Take the same procedure at each mode with Dolby ON.	better than 35dB	Use 1kHz band-pass filter. Dolby OFF Dolby ON
31.	Crosstalk Check	MIT-121				Play-back test tape MIT-121, and measure the leakage as per the following mode. Lch to Rch (1st track to 2nd track) Rch to Lch (2nd track to 1st track)	better than 50dB	Use 1kHz band-pass filter.

K-12 MECHANICAL PART ALIGNMENT PROCEDURE

NO.	ITEMS	TAPE REQUIRED	SELECTOR EQ SW	POSITION BIAS SW	INPUT SIGNAL	ALIGNMENT PROCEDURE	LIMITED SPEC	REMARKS
1.	Check of Eject Sw.					1) Confirm that the deck does not stop and that the cassette lid does not open even when the Eject Button is pressed during operation. 2) Confirm that in the modes of "FF" and "REW" with a touch to the Eject Button the deck stops operation prior to opening of the cassette lid.		
2.	Check of Bias Osc. Sw.					Confirm that the bias osc. switch is turned on when the head chassis functions and that it is not turned off at the STOP mode.		
3.	Check of Tape Speed	MIT-111D				Connect a digital counter to the LINE OUTPUT, and with MIT-111D tape the digital counter shows 2,985 - 3,015Hz.	Tape speed: 2,985-3,015Hz	
4.	Check of Wow	MIT-111D				The wow tape MIT-111D is loaded, and a wow meter is connected to the LINE OUT terminal. Wow is measured both at RMS and WRMS.	RMS: below 0.1% WRMS: below 0.04%	

Key Switch PCB

SYMBOL NO.	PART NUMBER	DESCRIPTION	NOTE	QUANTITY PER UNIT
	PCM-004	Key Switch PCB	PCM004	1
	S-0018	Key Tact Switch		7
	A-0021	Lamp	5V0.075A	3
	YM-0199	Bush 3008		3

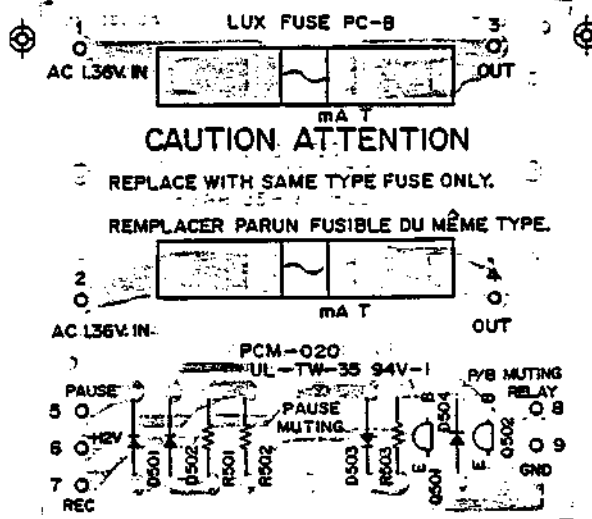
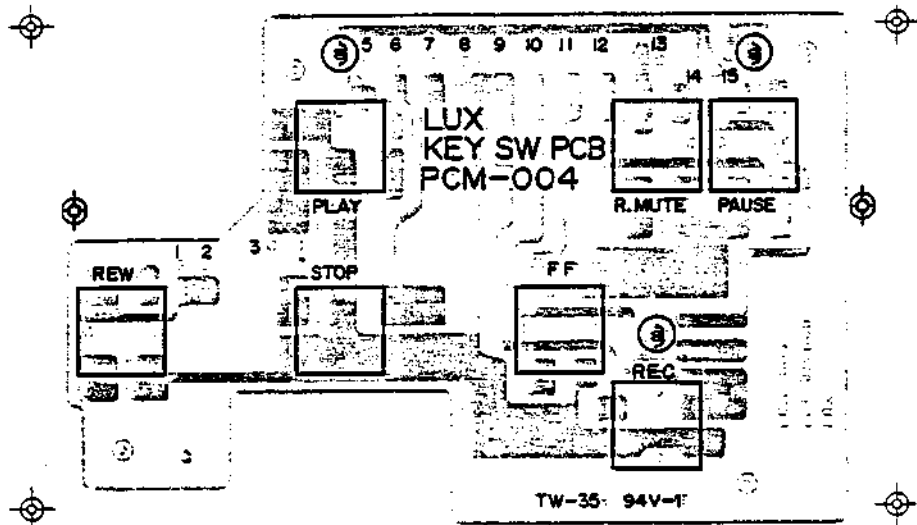

Fuse PCB

SYMBOL NO.	PART NUMBER	DESCRIPTION	NOTE	QUANTITY PER UNIT
	PCM-020	Fuse PCB	PCM-020	1
Q501, 502	T-0025	Transistor	2SC2320F	2
D501~504	T-0010	Diode	1S-2473	4
R503	R-0001	Carbon Resistor	1/4W 3.9KΩ	1
R502	"	"	" 10KΩ	1
R501	"	"	" 47KΩ	1

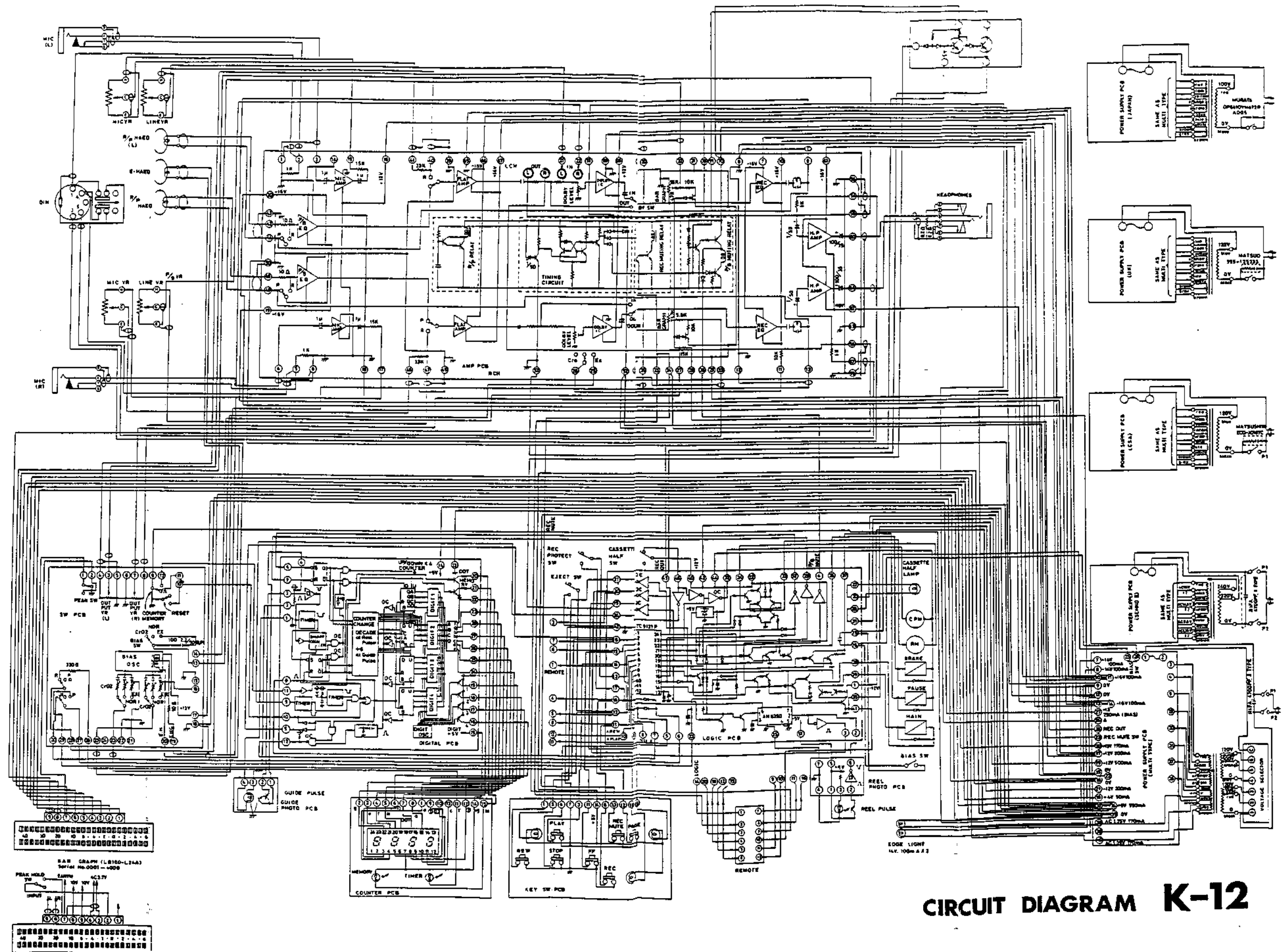

CIRCUIT DIAGRAM K-12

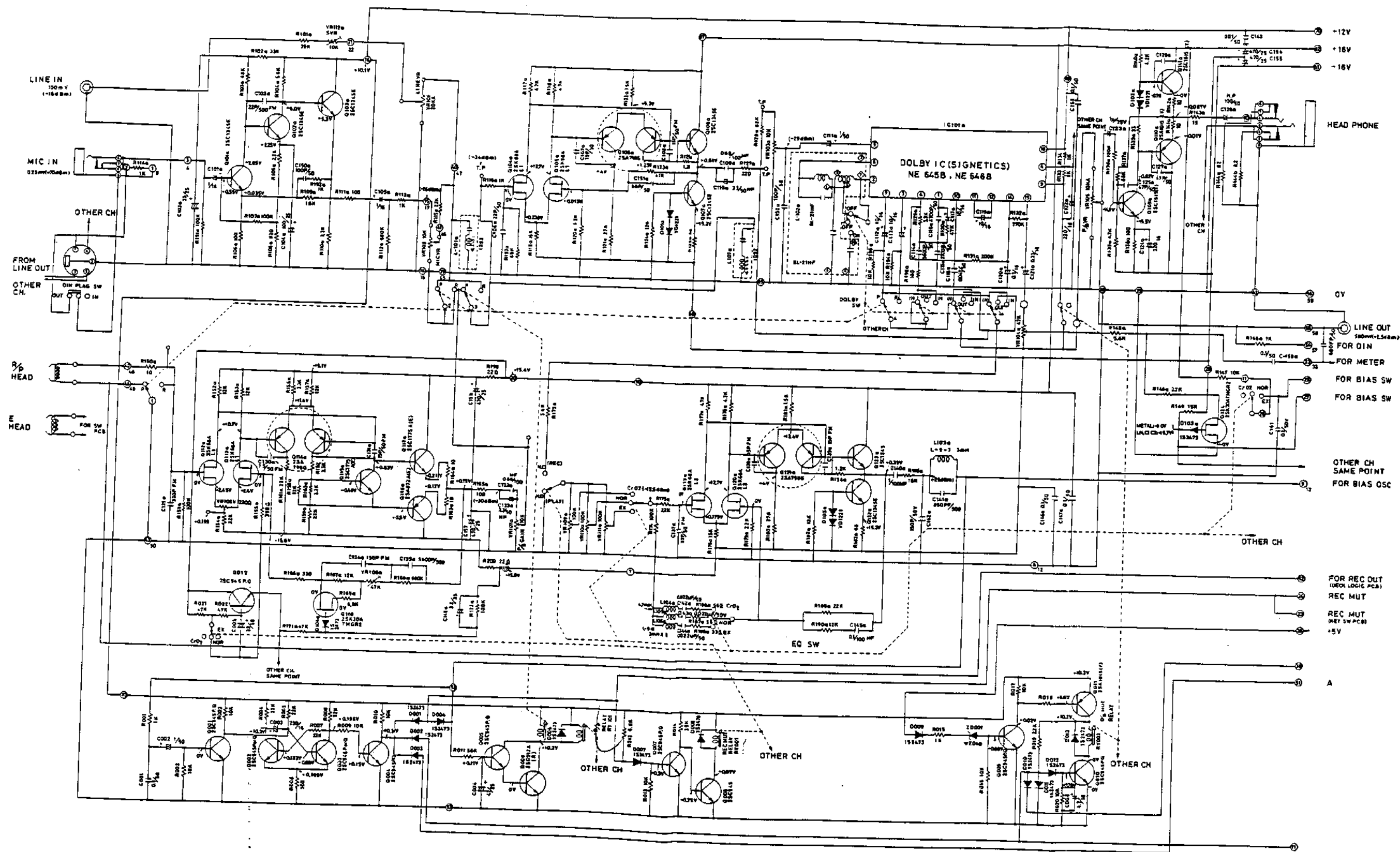

AMPLIFIER CIRCUIT K-12

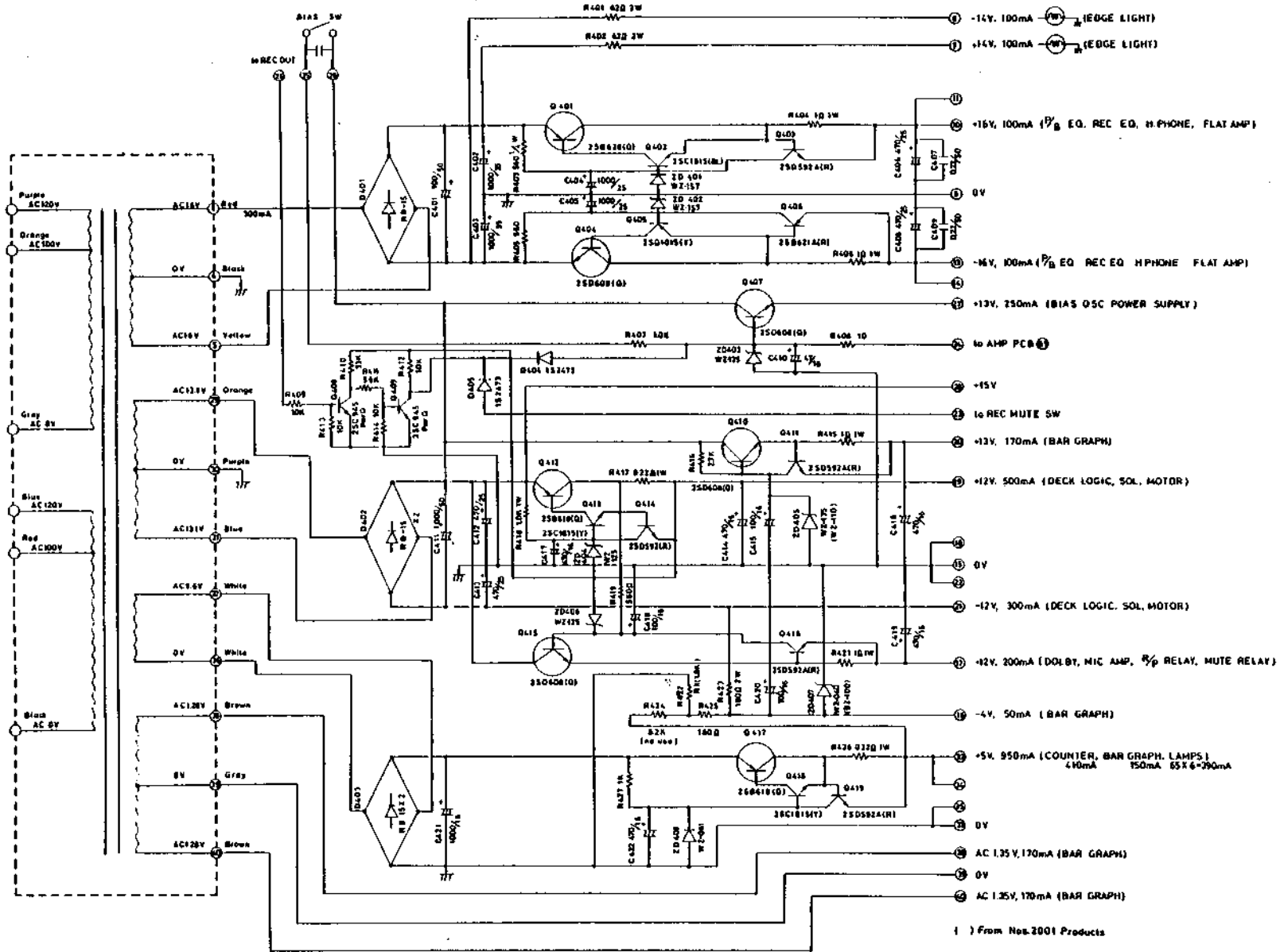

K-12 POWER SUPPLY CIRCUIT

(C)----- Ceramic Condenser
 (S)----- Styral Condenser

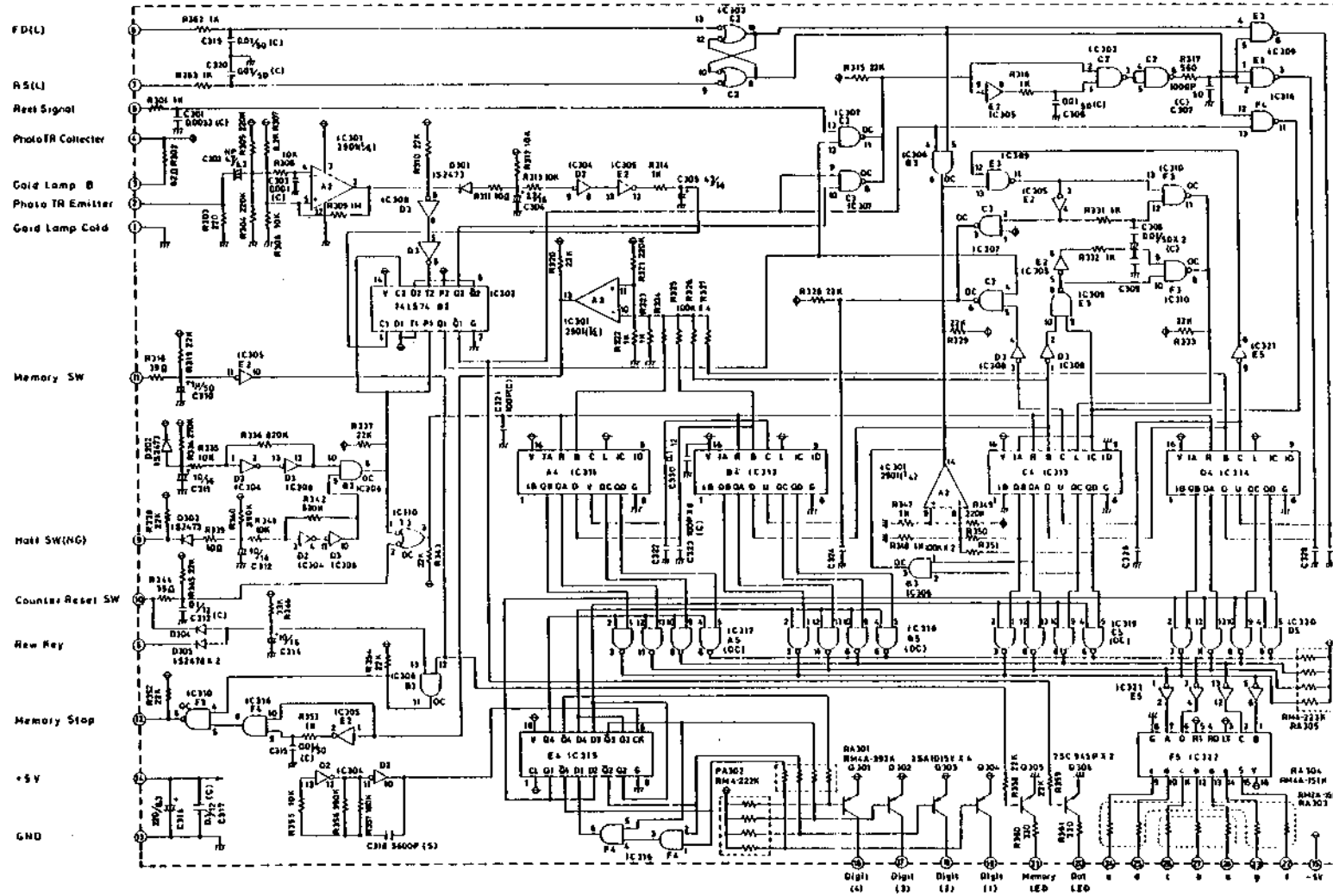

K-12 DIGITAL PCB CIRCUIT

LUX CORPORATION, JAPAN

1-1, 1-CHOME, SHINSENRI-NISHIMACHI, TOYONAKA-SHI, OSAKA
PHONES: 06-834-2222 CABLE: LUXMAN TOYONAKA TELEX: J63694

0880-1000(STD)

Printed in Japan