

SERVICE MANUAL

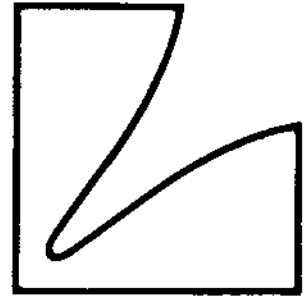

LUXMAN STEREO CASSETTE DECK **K-05**

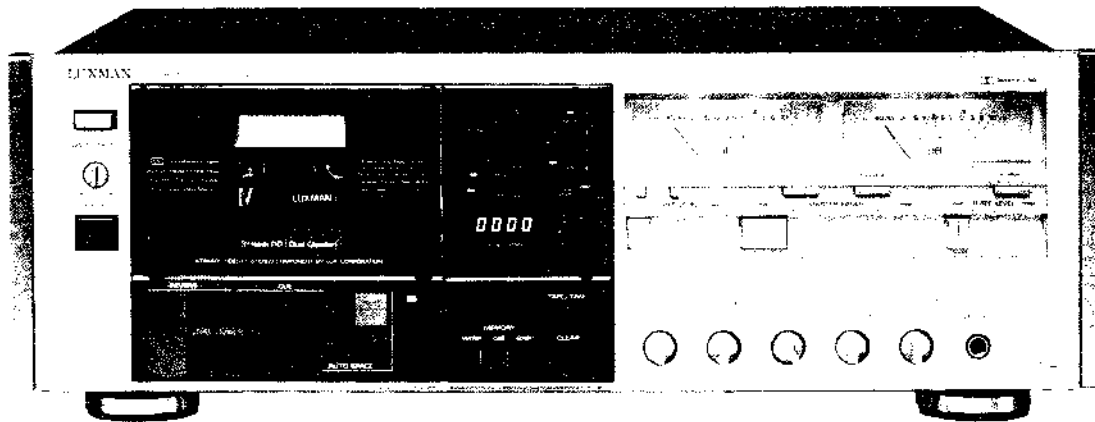

K-05

Contents

Block Diagram	1
Adjustment Locations	2
Alignment Procedure	3~13
調整手順書	14~20
Destination's Parts List	21
Packing Material Parts List	22
Exploded View (1)	23
Exploded View (2)	27
Exploded View FD Mechanism(New Type)	30
Exploded View FR Mechanism(Old Type)	33
Exploded View (1) Parts List	24~26
Exploded View (2) Parts List	28, 29
Exploded View FD Mechanism Parts List	31, 32
Exploded View FR Mechanism Parts List	34, 35
Mother PCB	36
Lamp PCB	36
Dolby PCB	37
REC EQ PCB	37
Control PCB	38
LED & SW PCB	38
VR & SW PCB	38
Pintch Control PCB	39
Line Sensor PCB	39
Auto Erase PCB	39
Memory Key PCB	39

Pulse OSC PCB	39
Key Board SW PCB	39
NR SW PCB	39
Mother PCB Parts List	40~44
Lamp PCB Parts List	44
Dolby PCB Parts List	45, 46
REC EQ PCB Parts List	46, 47
Control PCB Parts List	47~49
LED & SW PCB Parts List	49
VR & SW PCB Parts List	49
Pintch Control PCB Parts List	49
Line Sensor PCB Parts List	49
Auto Erase PCB Parts List	50
Memory Key PCB Parts List	50
Pulse OSC PCB Parts List	50
Key Board SW PCB Parts List	50, 51
NR SW PCB Parts List	51
IC Handling Guide	52~56
Schematic Diagram (1)	57
Schematic Diagram (2)	58
Schematic Diagram (3)	59
Schematic Diagram (4)	60
Schematic Diagram (5)	61
Specifications	62
規格	63

Block Diagram

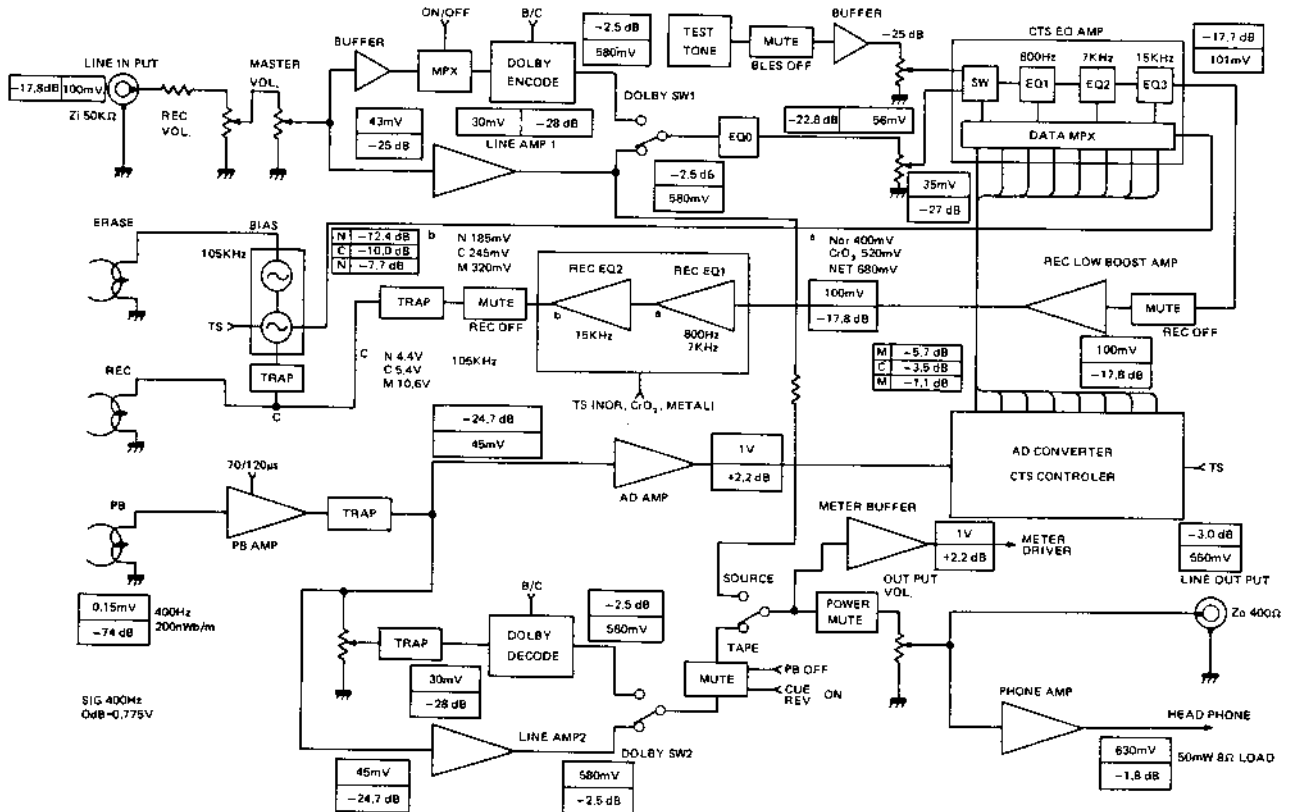

K-05

Adjustment Procedures

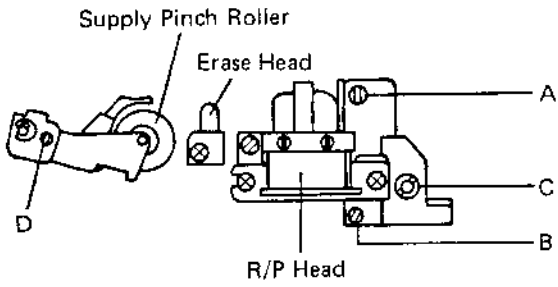

Figure 24

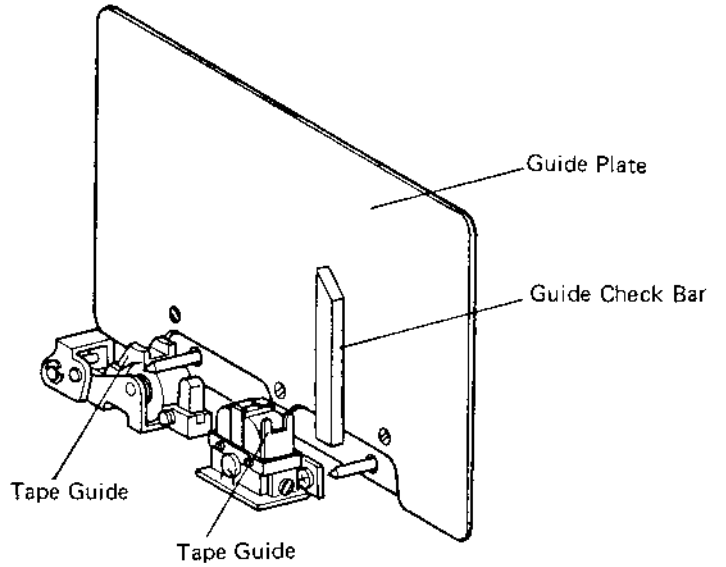

Figure 25

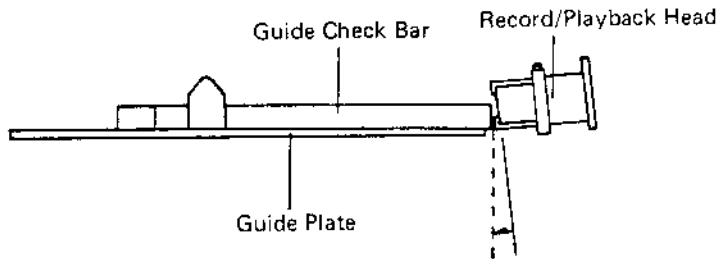

Figure 26

CONNECTION DIAGRAMS

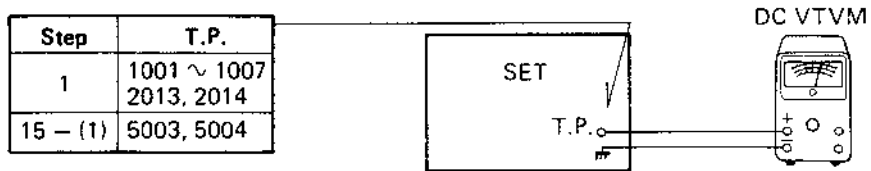

Figure 27

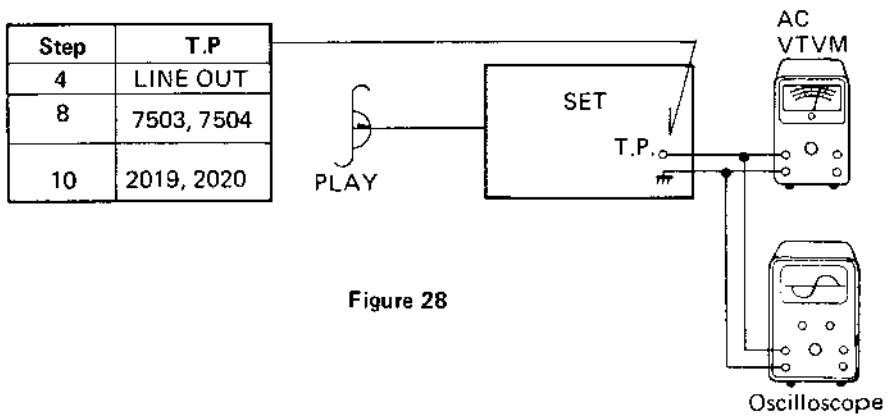

Figure 28

K-05

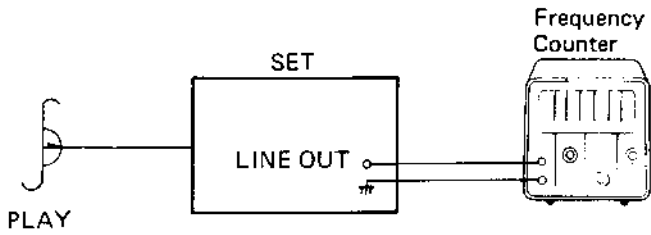

Figure 29

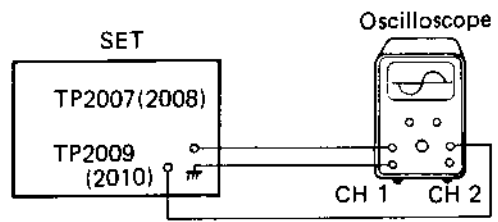

Figure 30

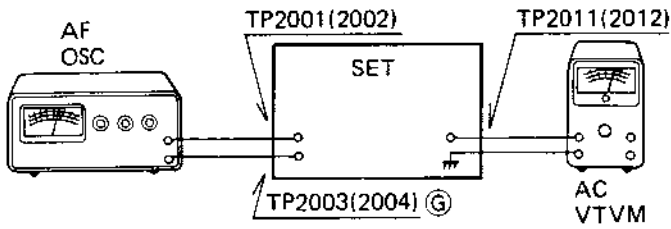

Figure 31

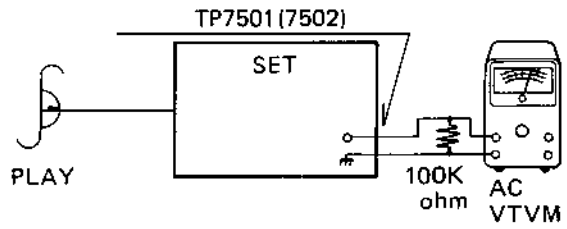

Figure 32

Step	T.P
11	7003, 7004
14	LEVEL METER
15 - (2), (3)	5005, 5006

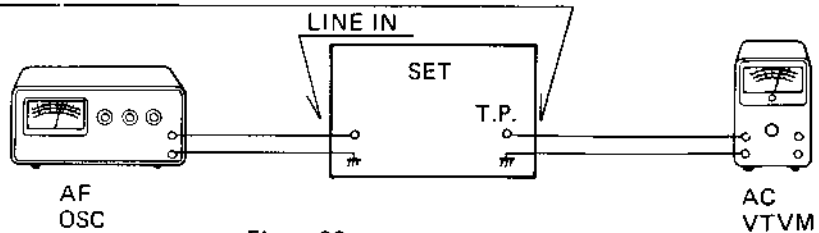

Figure 33

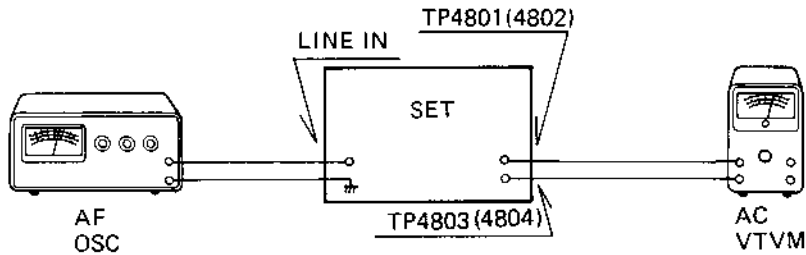

Figure 34

Step	T.P
12	7001, 7002
19	LINE OUT

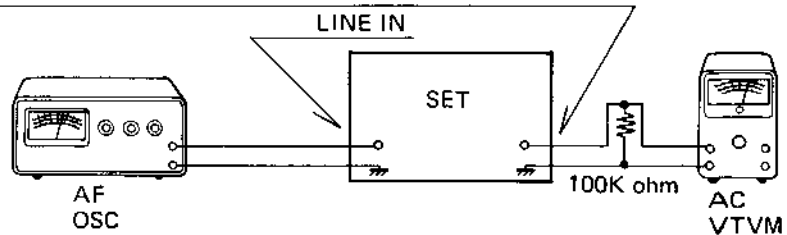

Figure 35

14.05

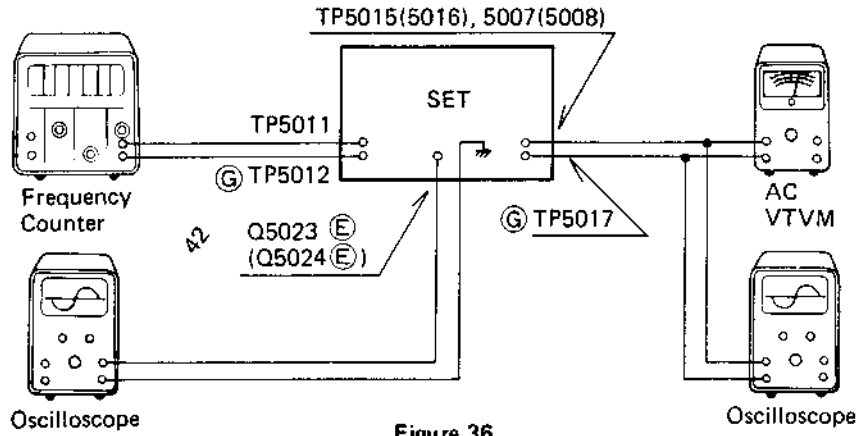

Figure 36

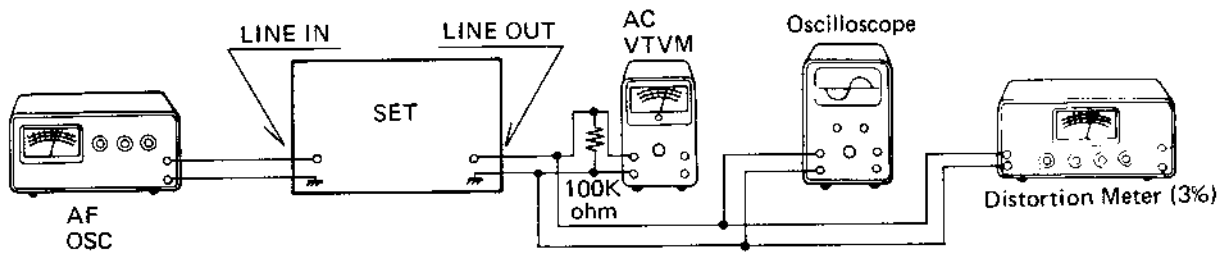

Figure 37

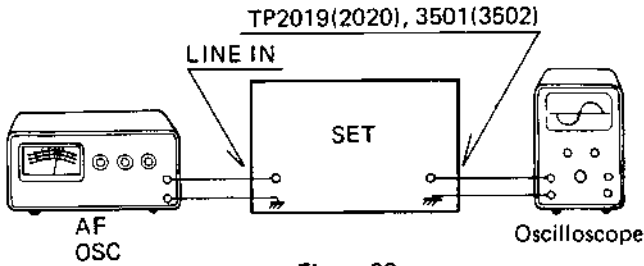

Figure 38

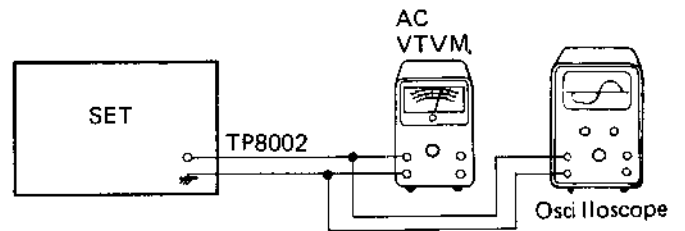

Figure 39

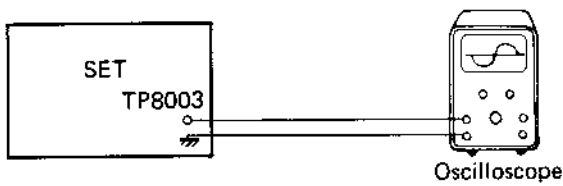

Figure 40

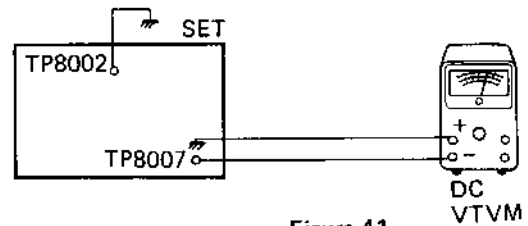

Figure 41

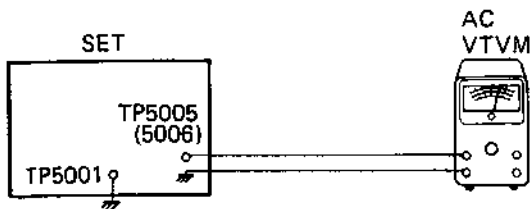

Figure 42

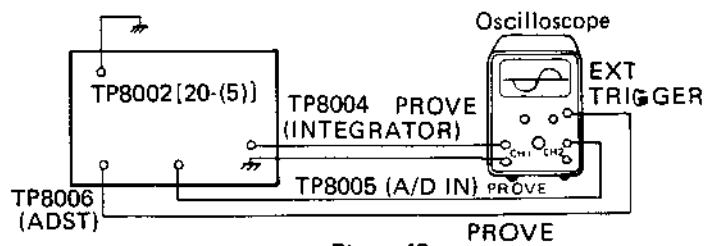

Figure 43

Notes: (1) Adjustments are proceeded under the following conditions such as switch and volume settings unless otherwise noted.

1. MONITOR switch: TAPE
2. PEAK/VU left & Right meters: PEAK
3. TAPE SELECT switch: NORM
4. DOLBY NR select switch: OFF
5. DATA STD/CALL switch: STD
6. PITCH CONTROL: Center
7. BIAS FINE control: Center
8. OUTPUT LEVEL control: Maximum
9. Other switches: Off position

(2) The MASTER FADER and REC LEVEL volumes on these adjustments follow as positions in step 11.

Step	Adjustment Items	Mode	Adjustment Parts	Test Points	Connection	Remarks																								
1	DC Voltage check	STOP			Figure 27	<p>Check voltage at each Test Point.</p> <table border="1"> <tr> <td>Test Point</td> <td>TP1001</td> <td>TP1002</td> <td>TP1003</td> <td>TP1004</td> <td>TP1005</td> </tr> <tr> <td>Voltage(V)</td> <td>24 ± 1</td> <td>12 ± 1</td> <td>-12 ± 1</td> <td>18</td> <td>12 ± 1</td> </tr> <tr> <td>Test Point</td> <td>TP1006</td> <td>TP1007</td> <td>TP2013</td> <td>TP2014</td> <td></td> </tr> <tr> <td>Voltage(V)</td> <td>9</td> <td>6 ± 1</td> <td>10 ± 1</td> <td>-10 ± 1</td> <td></td> </tr> </table>	Test Point	TP1001	TP1002	TP1003	TP1004	TP1005	Voltage(V)	24 ± 1	12 ± 1	-12 ± 1	18	12 ± 1	Test Point	TP1006	TP1007	TP2013	TP2014		Voltage(V)	9	6 ± 1	10 ± 1	-10 ± 1	
Test Point	TP1001	TP1002	TP1003	TP1004	TP1005																									
Voltage(V)	24 ± 1	12 ± 1	-12 ± 1	18	12 ± 1																									
Test Point	TP1006	TP1007	TP2013	TP2014																										
Voltage(V)	9	6 ± 1	10 ± 1	-10 ± 1																										
2	Head Height and Tilt Angle		Screws A, B (Figure 24)			<ul style="list-style-type: none"> ● Measurement Gauge: M-300 1. Head Height (Figure 25) The guide check bar should smoothly pass through the tape guide. 2. Tilt Angle (Figure 26) The guide check bar should stay in parallel with the guide plate or the top of the guide check bar should tilt a little forward you. 																								
3	Tape Guide of Supply Pinch Roller		Screw D (Figure 24)			<ul style="list-style-type: none"> ● Measurement Gauge: M-300 The guide check bar should smoothly pass through the tape guide of supply pinch roller. (Figure 25) 																								
4	Head Azimuth	PLAY	Screw C (Figure 24)	LINE OUT	Figure 28	<ul style="list-style-type: none"> ● Test Tape: MTT-114 (10 KHz) The left and right outputs are in-phase and maximum and equal in amplitude. If the azimuth screw movement is too large, readjust the head height and Tilt angle in step 2. 																								
5	Tape Speed	PLAY	VR001	LINE OUT	Figure 29	<ul style="list-style-type: none"> ● Test Tape: MTT-111 (3,000 Hz) Adjust VR001 to obtain output frequency reading of 3,000 ± 10 Hz 																								

Step	Adjustment Items	Mode	Adjustment Parts	Test Points	Connection	Remarks								
6	DC Balance of playback Equalization Amplifier	STOP	VR2003(L) VR2004(R)	TP2007(L) TP2009(L) TP2008(R) TP2010(R)	Figure 30	<p>1. Switch the oscilloscope to DC range and adjust both voltage in CH1 and CH2 to the same value approximately 0.65V.</p> <p>* Voltage variations at TP2009 and TP2010 are small.</p>								
7	Playback EQ and Peak Point	PLAY	S2001 VR2001 } L S2002 VR2002 } R	TP2011(L) TP2012(R)	Figure 31	<p>1. Set unit to playback mode with a blank tape loaded.</p> <p>2. Feed 200 Hz test signal from AF oscillator and adjust oscillator output so that 1V (= 0 dB) output is developed at each test point. Change oscillator frequency to 20 Hz and 7 kHz so that output levels shown below are obtained. Change oscillator frequency to 27 kHz and adjust S2001, 2002, VR2001, 2002 to find a peak level so that a peak is developed between 26 kHz and 27 kHz.</p> <table border="1"> <thead> <tr> <th>Frequency Hz</th> <th>20</th> <th>7K</th> <th>26K ~ 27K</th> </tr> </thead> <tbody> <tr> <td>Output dB</td> <td>+11</td> <td>-15.5</td> <td>-9 ~ -12</td> </tr> </tbody> </table> <p>3. Check for -15.5 dB output at 7 kHz.</p> <p>4. Check for -20 dB output at 7 kHz when Metal position is selected.</p>	Frequency Hz	20	7K	26K ~ 27K	Output dB	+11	-15.5	-9 ~ -12
Frequency Hz	20	7K	26K ~ 27K											
Output dB	+11	-15.5	-9 ~ -12											
8	Dolby Level 1	PLAY	VR3501(L) VR3502(R)	TP7503(L) TP7504(R)	Figure 28	<ul style="list-style-type: none"> Test tape: MTT-150 (400 Hz) Adjust to obtain 580mV output at each test point. 								
9	Dolby Level 2	PLAY	VR3801(L) VR3802(R)	TP7501 TP7502	Figure 32	<ul style="list-style-type: none"> Test tape: MTT-150 Adjust to obtain 580mV output at each test point. 								
10	Dolby Level (A/D Buffer) Out	PLAY	VR2007(L) VR2008(R)	TP2019(L) TP2020(R)	Figure 28	<ul style="list-style-type: none"> Test tape: MTT-150 Adjust to obtain 1000mV output at each test point. 								
11	Input Sensitivity Reference level (Dolby Level)	STOP MONITOR: SOURCE	REC LEVEL VOLUME, MASTER FADER VOLUME	TP7003(L) TP7004(R)	Figure 33	<p>AF OSC: 400 Hz, 106±18mV (Dolby level) Input.</p> <p>Adjust to obtain 580mV output at each test point.</p>								
12	Input sensitivity NR DEFECT	STOP MONITOR: SOURCE	VR3301(L) VR3302(R)	TP7001 TP7002	Figure 35	<p>AF OSC: 400 Hz, 106mV (Dolby level) Input.</p> <p>Adjust to obtain 580mV output at each test point.</p>								

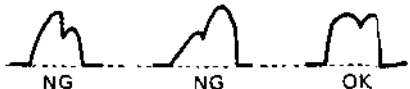
Step	Adjustment Items	Mode	Adjustment Parts	Test Points	Connection	Remarks								
13	Level Meter Input	STOP MONITOR: SOURCE	VR4801(L) VR4802(R)	TP4801 } L TP4803 } TP4802 } R TP4804 }	Figure 34	<ol style="list-style-type: none"> Adjust each the left and right channels independently. AF OSC: 400 Hz, 335mV (Dolby level +10 dB) Input. Adjust to obtain 1000mV reading between TP4801 & TP4803 (TP4802 & TP4804). 								
14	Level Meter 0 dB reading	STOP MONITOR: SOURCE	VR4803(L) VR4804(R)	Level Meter	Figure 33	<ol style="list-style-type: none"> AF OSC: 400 Hz, 106mV (Dolby level) Input. Adjust for 0 dB reading on Level Meter. AF OSC: Decrease oscillator output level by 20 dB. Check the level meter pointer indicates -20 dB. AF OSC: Increase oscillator output level by 10 dB from 106mV reference level. Check the level meter pointer indicates +10 dB. 								
15	AUTO EQ IC (1) Internal reference voltage	STOP MONITOR: SOURCE	VR5005(L) VR5006(R)	TP5003(L) TP5004(R)	Figure 27	Adjust to obtain 3.0V DC output at each test point. (Variable range should be within approx. 2.25 ~ 4.5V.)								
	(2) Input level	REC/PLAY	VR5001(L) VR5002(R)	TP5005(L) TP5006(R)	Figure 33	TEST TAPE: BLANK TAPE AF OSC: 800 Hz, 106mV (Dolby Level) Input Adjust to obtain 100mV output at each test point.								
	(3) Peaking fo		L5001(L) L5002(R)	TP5005(L) TP5006(R)		AF OSC: 30 kHz, 5.95mV (-25 dB) Input. Adjust to obtain maximum output at each test point.								
16	BIAS (1) OSC Frequency (ERASE)	REC/PAUSE T. SELECT: METAL	L5006	TP5011 TP5012(G)	Figure 36	TEST TAPE: BLANK TAPE Adjust to obtain frequency reading of 105 kHz at test point. The output level under this condition should be approx 55mV (110mA). * TP E Vcc Value approx <table border="1" style="margin: 10px auto;"> <thead> <tr> <th>T. Select</th> <th>METAL</th> <th>CrO₂</th> <th>NORM</th> </tr> </thead> <tbody> <tr> <td>V</td> <td>12</td> <td>8.8</td> <td></td> </tr> </tbody> </table>	T. Select	METAL	CrO ₂	NORM	V	12	8.8	
	T. Select	METAL	CrO ₂	NORM										
V	12	8.8												
(2) Bias Current	REC/PLAY T. SELECT: METAL	L5005	TP5015(L) TP5016(R) TP5017(G)	<ol style="list-style-type: none"> TEST TAPE: BLANK TAPE Connect oscilloscope to emitter of Q5023 (Q5024) and adjust to obtain scope display shown below with maximum amplitude across test points.  <p>Emitter output voltage wave forms of Q5023 (Q5024)</p>										

Step	Adjustment Items	Mode	Adjustment Parts	Test Points	Connection	Remarks	
	Bias Current Temporarily Setting	REC/PLAY				2. TEST TAPE: BLANK TAPE Check oscillator frequency set in step 16 (1), and if the frequency has been upset, proceed steps 16 (1) ~ (2).	
		T. Select	L, R			Bias Current *Voltage at TP5013 (B, Vcc) approx	
		METAL	VR5013, VR5014			7.0mV (3.5mA) 12V	
		CrO ₂	VR5011, VR5012			4.0mV (2.0mA) 6V	
		NORM	VR5007, VR5008			3.0mV (1.5mA) 5V	
		(3) Bias Trap	REC/PLAY T. SELECT: METAL	L5003 } L L5007 } L5004 } R L5008 }	TP5007(L) TP5008(R)		1. TEST TAPE: BLANK TAPE Adjust to obtain minimum amplitude of Bias voltage wave form at each test point. 2. Check oscillator frequency set in step 16 (1), and if the frequency has been upset, readjust the frequency according to steps 16 (1) ~ (3).
	17	Peak Bias	REC/PLAY		LINE OUT	Figure 37	1. Level AF OSC: 400 Hz, 106mV Adjust Level Adjust Volume until record/playback output of 550mV, which is the same level as that of SOURCE, is obtained. 2. Bias AF OSC: 400 Hz, 100mV (Dolby Level) Input. Adjust Bias Adjust Volume so that Distortion Values shown in table below is obtained.
			T. Select	L, R			
		METAL	Level	VR5509, VR5510			
			Bias	VR5013, VR5014			
		CrO ₂	Level	VR5511, VR5512			
			Bias	VR5011, VR5012			
		NORM	Level	VR5515, VR5516			
			Bias	VR5007, VR5008			

Reference Tape	AF OSC Level	Distortion	Line Out Level
AC-711	106mV	—	550mV
	106mV	1.3%	appo x. 550mV
AC-512	106mV	—	550mV
	106mV	1.3%	appo x. 550mV
AC-223	106mV	—	550mV
	106mV	1.3%	appo x. 550mV

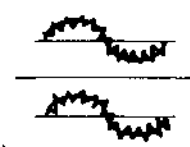
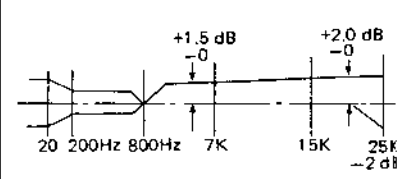
Step	Adjustment Items	Mode	Adjustment Parts	Test Points	Connection	Remarks																
18	PB AMP Bias Trap	REC/PLAY T. SELECT: METAL	L2001 } L L2003 } L2002 } R L2004 }	TP2019(L) TP2020(R)	Figure 38	<p>1. AF OSC: 400 Hz, 56mV (-25 dB from 550mV) Line Out If record/playback output signal (wave form) is modulated or superimposed with high frequency signals (Bias signal), adjust for minimum amplitude of the high frequency signals.</p> <p>2. If level variation is observed at Dolby NR: C position, readjust L3501 & L3502 for maximum amplitude of scope display at 400 Hz.</p> <p>* Record/Playback output wave form superimposed with bias signal.</p> 																
19	Record/Playback Frequency Response	REC/PLAY				<p>AF OSC: 56mV (-25 dB from 550mV) Line Out</p>  <p>< Specifications of Record/Playback Frequency Response ></p> <p>Adjust respective trimming resistor so that record/playback frequency response within the above limits, (referred to 400 Hz) is obtained.</p>																
		T. Select				<table border="1"> <thead> <tr> <th>Reference Frequency 400 Hz L, R</th> <th>Mid & Hi Frequencies 7 kHz L, R</th> <th>High Frequency 15 kHz L, R</th> <th>Reference Tape</th> </tr> </thead> <tbody> <tr> <td>VR5509, VR5510</td> <td>VR5501, VR5502</td> <td>VR5517, VR5518</td> <td>AC-711</td> </tr> <tr> <td>VR5511, VR5512</td> <td>VR5503, VR5504</td> <td>VR5519, VR5520</td> <td>AC-512</td> </tr> <tr> <td>VR5515, VR5516</td> <td>VR5507, VR5508</td> <td>VR5523, VR5524</td> <td>AC-223</td> </tr> </tbody> </table>	Reference Frequency 400 Hz L, R	Mid & Hi Frequencies 7 kHz L, R	High Frequency 15 kHz L, R	Reference Tape	VR5509, VR5510	VR5501, VR5502	VR5517, VR5518	AC-711	VR5511, VR5512	VR5503, VR5504	VR5519, VR5520	AC-512	VR5515, VR5516	VR5507, VR5508	VR5523, VR5524	AC-223
		Reference Frequency 400 Hz L, R	Mid & Hi Frequencies 7 kHz L, R	High Frequency 15 kHz L, R	Reference Tape																	
		VR5509, VR5510	VR5501, VR5502	VR5517, VR5518	AC-711																	
		VR5511, VR5512	VR5503, VR5504	VR5519, VR5520	AC-512																	
VR5515, VR5516	VR5507, VR5508	VR5523, VR5524	AC-223																			
METAL																						
CrO ₂																						
NORM																						

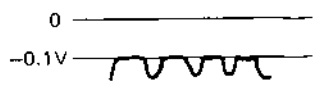
Step	Adjustment Items	Mode	Adjustment Parts	Test Points	Connection	Remarks								
						<p>* A. If the frequency response is out of specifications, try to re-adjust, using following steps:</p> <ol style="list-style-type: none"> Step 19 Steps 2 ~ 4 Step 17 (Try to change bias signal level within a range on which audio output distortion does not exceed maximum limit.) <p>B. If the frequency response is out of specifications over high end, try to repeat step 7.</p>								
20	AUTO EQ (1) TONE OSC LEVEL	STOP TONE OSC: 800 Hz S8001: TEST S8002: TEST	VR8002	TP8002	Figure 39	<ol style="list-style-type: none"> Short-circuit all four terminals (-6, MUTE, OSC φ, OSC 1) of TEST CN (CB8001). Place S8001 & S8002 in TEST positions. Monitor 800 Hz wave from at test point. Adjust for VTVM reading of 56mV. <p>* TONE OSC frequency can be varied as shown below by changing combinations of terminal connections.</p> <table border="1"> <thead> <tr> <th>TONE OSC Frequency</th> <th>15 kHz</th> <th>7 kHz</th> <th>800 Hz</th> </tr> </thead> <tbody> <tr> <td>TEST CN Terminals to be short-circuited</td> <td>-6, MUTE, OSC φ</td> <td>-6, MUTE, OSC 1</td> <td>-5, MUTE, OSC 1, OSC φ</td> </tr> </tbody> </table>	TONE OSC Frequency	15 kHz	7 kHz	800 Hz	TEST CN Terminals to be short-circuited	-6, MUTE, OSC φ	-6, MUTE, OSC 1	-5, MUTE, OSC 1, OSC φ
TONE OSC Frequency	15 kHz	7 kHz	800 Hz											
TEST CN Terminals to be short-circuited	-6, MUTE, OSC φ	-6, MUTE, OSC 1	-5, MUTE, OSC 1, OSC φ											
	A/D (2) CONVERTER GAIN	STOP TONE OSC: 800 Hz S8001: TEST S8002: TEST	VR8003	TP8003	Figure 40	<p>Adjust to obtain scope display shown below:</p>  <p>* Set oscilloscope to DC mode.</p>								
	A/D CONVERTER OFF-SET (3)	STOP TONE OSC: 800 Hz S8001: TEST S8002: TEST	VR8004	TP8007 (IC8006 of ①pin)	Figure 41	<ol style="list-style-type: none"> ADjust to obtain -160mV DC at test point. Check the DC output decreases to -8mV when TP8002 is grounded. 								

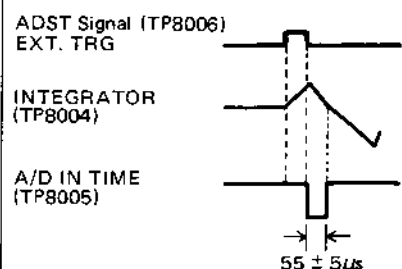
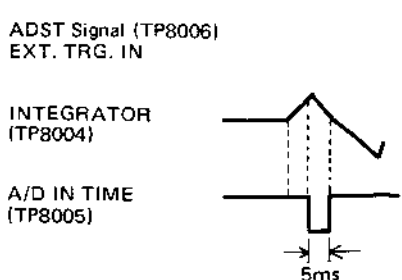
Step	Adjustment Items	Mode	Adjustment Parts	Test Points	Connection	Remarks
	(4) AUTO EQ TEST OSC SELECTION (Built-in OSC)	REC/PLAY TONE OSC: 800 Hz S8001: TEST S8002: TEST	VR5003(L) VR5004(R)	TP5005(L) TP5006(R)	Figure 42	<ol style="list-style-type: none"> 1. Connect TP5001 to GND. 2. Adjust to obtain 5.6mV at each test point.
	(5) A/D IN (A/D CONVERTER) OFF-SET	STOP CTS: ON TONE OSC: 800 Hz S8002: TEST	VR8004	TP8002 TP8004 TP8005 TP8006	Figure 43	<ol style="list-style-type: none"> 1. Set oscilloscope to EXT TRIGGER mode and adjust the trigger level so that oscilloscope is triggered by ADST (TP8006) signal when CTS switch is placed in ON position. Next, short-circuit INPUT terminals and bring oscilloscope's horizontal line to center of screen. Set oscilloscope to DC INPUT, 2V/cm & 20 μs of sweep time. 2. Connect TP8002 to GND. 3. Place CTS switch in ON position, and adjust so that A/D IN TIME (Output wave form of period at TP8005) of 50 ~ 60 μs is obtained.  <p>ADST Signal (TP8006) EXT. TRG</p> <p>INTEGRATOR (TP8004)</p> <p>A/D IN TIME (TP8005)</p> <p>55 ± 5 μs</p>
	(6) A/D IN (A/D CONVERTER) GAIN	STOP CTS: ON TONE OSC: 800 Hz S8001: TEST S8002: TEST	VR8003	TP8002 TP8004 TP8005 TP8006	Figure 43	<ol style="list-style-type: none"> 1. Change sweep time range of oscilloscope from 20 μs to 1ms. 2. Disconnect TP8002 from GND. 3. Adjust so that A/D IN TIME (Output wave form of period at TP8005) of 5ms is obtained when CTS switch is placed in ON position.  <p>ADST Signal (TP8006) EXT. TRG. IN</p> <p>INTEGRATOR (TP8004)</p> <p>A/D IN TIME (TP8005)</p> <p>5ms</p>

Step	Adjustment Items	Mode	Adjustments Parts	Test Points	Connection	Remarks
21	HEAD Demagnetizer (1) Level	POWER ON ↑ ↓ POWER OFF	VR9001	TP9001 TP9005	Figure 44	1. Connect TP9001 to GND. 2. Adjust to obtain 3.16V output at test point.
	(2) OSC Frequency		VR9002			1. Adjust to obtain frequency reading of $880 \pm 1\text{Hz}$ at test point.

* After completion of alignment, remove (OPEN) TEST CONNECTOR to release S8001 & S8002 from TEST condition.

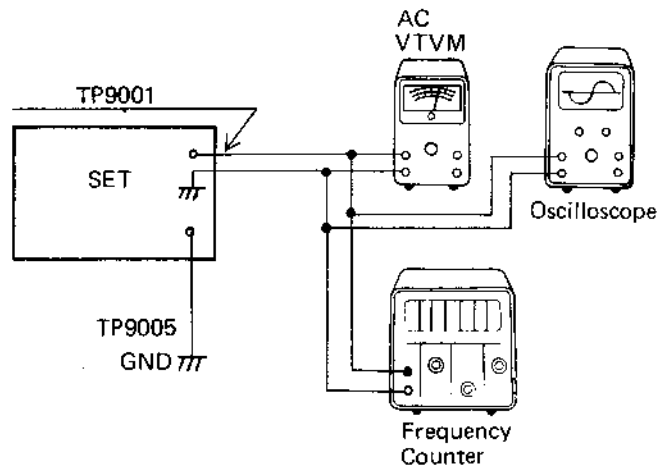
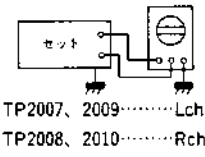
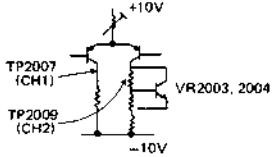
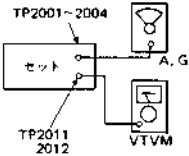
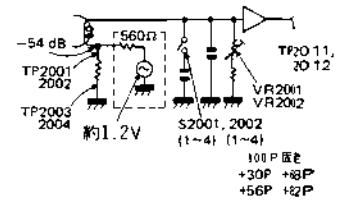
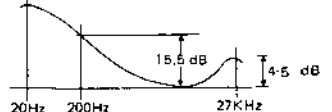
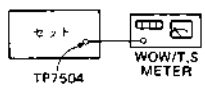
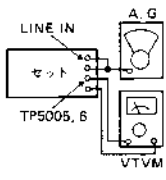
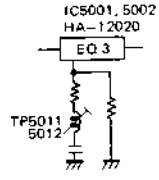
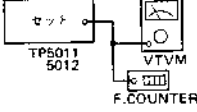
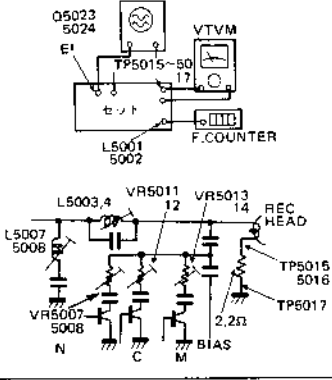
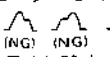
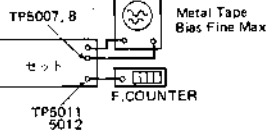
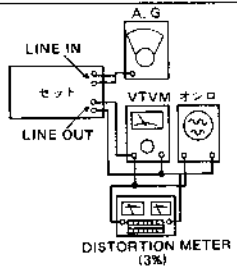
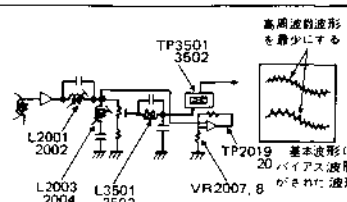
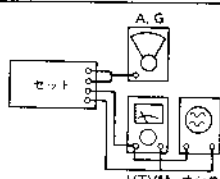
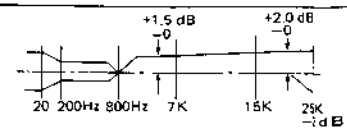

Figure 44

ステップ名称	セットの状態	調整位置	テストポイント	接続方法	手順・テストテープ・規格等
1. Power-ON チェック	STOP	目視			各部ライティングに異常がないか目視チェック異常の発生、発熱等がないかチェック。
2. DC 電圧の チェック	STOP		TP1001 TP1002 TP1003 TP1004 TP1005 TP1006 TP1007 TP2013 TP2014	24V±1V 12V±1V -12V±1V 18V 12V±1V 9V 6V±1V 10V±1V -10V±1V	テスター (DC 電圧計)
3. PB EQ AMP の DC バラン ス調整	PLAY	VR2003 VR2004	TP2007 TP2010	 <p>TP2007、2009……Lch TP2008、2010……Rch</p> 	L, R 別々に調整すること。 オシロを DC レンジにして CH1, 2 の電圧を調整する。 TP2007, 8……75±75mV (対 GND 間) (ボルトレンジ……最初 2 V/cm で粗調微調のとき 0.1V/cm とする) ※ TP2009、2010 側電圧は、約 0.65V を示し調整中も変動が少ない。 ブランクテープ (テープなし)
4. PB EQ AMP のピーキング 調整	PLAY TOP SELECT: NORM	S2001 S2002 VR2001 VR2002	TP2001 TP2004 TP2011 TP2012		 <p>約 1.2V</p> <p>EQ 12μS 70μS で 7 KHz で -20dB</p> <p>100P 直並 +30P +8P +56P +2P</p> <p>20Hz +11dBV 200Hz 0dB ……(1V) Ref 7 KHz -15.5dB 26~27KHz -9 dB ピークポイント ※ 200Hz で 0dBV 出力となる様、OS(出力)を微調整する。</p> 
5. T. S WOV	PLAY T. Seect: NORM DOLBY NR: OFF	デッナメカ VR	TP7504 (NRSW PANEL)		#111 3 KHz テストテープ TS 3000Hz + 10 Hz - 0 Hz (S-E の間) ピッチコン……センタークリック (約 8% 可変出来る) WOW……0.030 以下 $\bar{x}=0.025\%$

ステップ名称	セットの状態	調整位置	テストポイント	接続方法	手順・テストテープ・規格等
6. アジマス微調	PLAY T. S: NORM NR: OFF	アジマス スクリュー	TP7503 TP7504		#114 10KHz テストテープ 最大出力、同位相 (調整は50°以内に) STOP—PLAYで位相の安定度が悪いものは再調 (送行関係)
7. ドルビーレベル、I	PLAY T.S. NORM NR: OFF	VR3501 VR3502	TP7503 TP7504		#150 400Hz テストテープ 580mV (DOLBY IC MONITOR OUT の出力調整) * NR—OFFでも回路はCになっている。
8. ドルビーレベル、II	PLAY T. S: NORM NR: OFF	VR3801 VR3802	TP7501 TP7502		#150 テストテープ再生 580mV (DOLBY NR DEFEET (BU FFER) OUT の出力調整) *このとき LINE OUT からは、550mV出力となる。
9. ドルビーレベル (A D BUFFER OUT)	PLAY T. S: NORM NR: OFF	VR2007 VR2008	TP2019 TP2020	同上 (TP2019、2020に接続)	#150 テストテープ再生 1000mV
10. 入力感度基準レベル調整	SOURCE NR: OFF MIC VR: MIN	VR2803(MASTER) VR2801(REC VR) VR2802(REC VR)	TP7003 TP7004		OSC 400Hz LINE IN 106±18mV 580mV に調整 (DOLBY IC REC OUT 出力調整を REC VR で調整)
11. 入力感度調整 (NR—DEFEET)	SOURCE NR: OFF	VR3301 VR3302	TP7001 TP7002		OSC 400Hz LINE IN 106mV 580mV * LINE IN LEVEL 及び REC VR は、ステップ10と同じ。 *このとき、LINE OUT からは、約550mV出力となる。
12. レベルメータ入力調整	SOURCE NR: OFF P/VU: PEAK	VR4801 VR4802	TP4801 TP2804 TP4802		 L R片側 フック挿入 て調整のこと VTVMの GNDとセ ットのGND は離して おくこと OSC400Hz INPUT+10dB IN (+10dB DOLBY LEVEL) 1 kΩ 両端電圧で100mV に調整
13. レベルメータ OdB指示調整	SOURCE NR: OFF P/VU: PEAK	VR4803 4804	メーターの指針 (目視)		OSC 400Hz 106mV入力 DOLBY LEVELでメーターの指示をOdBに調整、 確認のため-20dBにしてレベルメータが+ 20dBとなる事をチェック。
14. AUTO EQ IC調整 a) 内部基準 電圧の調整	REC/PLAY SOURCE T. S: NORM NR: OFF STD	VR5005 5006	TP5003 5004		DC 3.0V (可変範囲は、2.25~4.5位)

ステップ名称	セットの状態	調整位置	テストポイント	接続方法	手順・テストテープ・規格等
b) 入力レベルの調整 (LINE IN)		VR5001 5002	TP5005 5006		※REC/PLAYにてMUTE解除(BRANK TAPE 使用) 入力0dB DOLBY LEVEL 100mVに調整 f=800Hz
c) ピーキング f_0 調整		L5001 5002	TP5005 5006		入力-25dB f: 30kHz レベル最大 
d) 入力レベルの調整 (内蔵OSC)		VR5003 5004	TP5005 5006 TP5001		TEST CN (CB8001) にショートコネクター接続して内蔵OSCの周波数を800Hz選択し合わせてミュートを解除する。 以下20) d) と同じ
15. バイアス a) OSC 周波数 (Erase)	REC/PAUSE T. S: METAL { CrO ₂ } { NORM }	L5006	TP5011 5012		周波数105KHzになる様L5006を調整する。 (この調整は各トラップ調整後105KHzより、ずれていれば再び行なうこと。) (METALで105 K±100HzCrO ₂ で104.8KHz位) 約55mV (110mA) を示す。 (参) Vcc METAL...12V TP, E C・N・F...8.8V Vcc
b) バイアス電流	REC/PLAY T. S: METAL { CrO ₂ } { NORM } B. F: センター	L5005 VR5007 5008 VR5011 VR5014	TP5015 5016 5017 Q5023, 5024 (Emitter)		L5005にてバイアス電流最大値に調整する。 (Q5023又は5024のEmitter波形をモニターして調整) ※周波数をモニターして105Kよりずれたら再調  バイアス電流仮設定 (参) BVcc M: 7.0mV (3.5mA) 12V C: 4.0mV (2.0mA) 6V N: 3.0mV (1.5mA) 5V
c) バイアス トラップ調整		L5003 5004 5007 5008	TP5007 5008		L5003, L5004及びL5007, L5008の調整でTP5007, TP5008のBIASもれレベルを最少にADJする。 Metal Tape Bias Fine MAX 時 波高値が0.5V (P-P) 以下のこと。 トラップコイルズレの有るときのみ再調を行なう。 (基板単体でコイルの調整をしているので普通は再調しない)
16. ピークバイアス調整	REC/PLAY T. S: METAL NR: OFF B. F: センター CrO ₂ NORM	VR5013 } 5014 } MeTal VR5509 } 5510 } VR5011, 5012 } VR5511, 5512 } VR5007, 5008 } VR5515, 5516 }			f: 400Hz 0dB (約 500mV) LINE IN TAPE: TDK AC711 録音出力を550mV (TAPE/SOURCE同レベル)に合わせながら約1.3%歪にバイアス調整する。 VR5013, 5014...MOTHER BOARD...バイアス量 VR5509, 5510...REC EQ PANEL...レベル調整

ステップ名称	セットの状態	調整位置	テストポイント	接続方法	手順・テストテープ・規格等																				
					<p>以下CrO₂、FeCr、NORMとも合わせる。 CrO₂…AC512 550mV 1.3% NORM…AC223 550mV 1.3%</p> <p>このときBIAS FINEを±へに可変して、レベルの変化がL、R同等になる様、L、又はRのBIASを再調する。 これにより、L、Rに多少の歪率アンバラが発生するが、L、Rの歪率を1.3~1.5%位の範囲に入る様、調整のこと。</p>																				
17. PBアンプ バイアス トラップ	REC/PLAY T. S: METAL NR: OFF B. F: センター	L2001 2002 L2003 2004 L3501 3502	TP2019 2020 3501 3502		 <p>高周波の波形を最少にする 基本波形に20 バイアス波形がされた波形</p> <p>-25dB、400Hz波形にバイアスモレがある場合は、L2001、2002、2003、2004を調整する。 ポイント f=250Hz NR-Cでレベル変動の最も少ないポイントを選ぶ (3 dB以下) (-25dB) 変動有る場合L3501、3502を後調整する。 これらの調整は初期チェックでOKならば、コイル調整は行なわなくて良い(基板単体で調整済のため)</p>																				
18. 録再F特調整	REC/PLAY T. S: METAL NR: OFF CrO ₂ NORM	VR5501 5524	J4001 LINE IN LINE OUT		 <p>上記の範囲を目標に調整する。</p> <table border="1"> <thead> <tr> <th></th> <th>基準レベル</th> <th>中 高 域</th> <th>高 域</th> </tr> <tr> <th></th> <th>800Hz</th> <th>7KHz</th> <th>5KHz</th> </tr> </thead> <tbody> <tr> <td>Metal (AC-711)</td> <td>VR5508 5510</td> <td>VR5501 5502</td> <td>VR5517 5518</td> </tr> <tr> <td>CrO₂ (AC512)</td> <td>VR5511 5512</td> <td>VR5503 5504</td> <td>VR5519 5520</td> </tr> <tr> <td>NORM (AC-223)</td> <td>VR5515 5516</td> <td>VR5507 5508</td> <td>VR5523 5524</td> </tr> </tbody> </table> <p>各テープにて上記調整用VRにて調整 場合によってはくり返し調整する必要があり、又バイアスも初期値より多少の再調を要する場合も有る。 (歪率で~2.3%位まで)</p> <p>基準レベル調整のときOdB調整と-25dB調整で差の有る場合は、-25dB調整を優先する。 7 KHz 15KHzの調整は+0.5~1.0dBを目標に合わせる。</p> <p>上記dB値は、基準周波数のSOURCEの値に対する各周波数のTAPEの値、15KHzの調整はレベル変動ひびクロスフィードの影響があるのでスイープ又は巻きもととして再生してチェックのこと。</p>		基準レベル	中 高 域	高 域		800Hz	7KHz	5KHz	Metal (AC-711)	VR5508 5510	VR5501 5502	VR5517 5518	CrO ₂ (AC512)	VR5511 5512	VR5503 5504	VR5519 5520	NORM (AC-223)	VR5515 5516	VR5507 5508	VR5523 5524
	基準レベル	中 高 域	高 域																						
	800Hz	7KHz	5KHz																						
Metal (AC-711)	VR5508 5510	VR5501 5502	VR5517 5518																						
CrO ₂ (AC512)	VR5511 5512	VR5503 5504	VR5519 5520																						
NORM (AC-223)	VR5515 5516	VR5507 5508	VR5523 5524																						

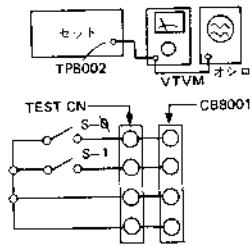
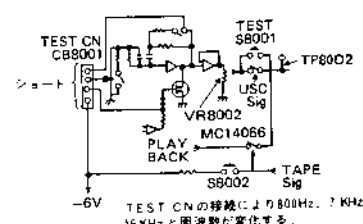
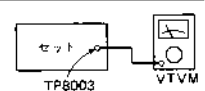
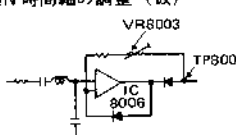
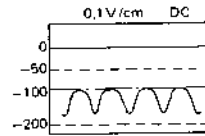
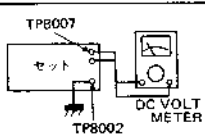
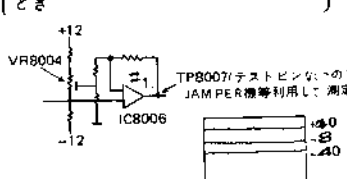
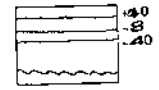
ステップ名称	セットの状態	調整位置	テストポイント	接続方法	手順・テストテープ・規格等												
19. 録再F特 (NR-OFF)	REC/PLAY		J4001 LINE IN LINE OUT		<p>高域スベックより1.5dB位余裕をもって入る様NR-OFF調整を行なう。</p> <p>特にNR-Cでは200~300Hzの盛り上がりがあるのでレベル調整にも注意を要する。 (SOURCE値より高く調整すると盛り上がりが大きくなる)</p> <p>又DOLBY ICのランク分け使用により高域のレベルが下がる傾向に有るので、NR-OFFで高域が下がらない様調整する→プラス傾向に調整する。又800Hzのレベルが下がっていると10K~13KHzのへこみが大きくなりやすい。</p>												
20. AUTO EQ a)TONE OSC レベル	STOP S8001 8002 TEST	VR8002	TP8002	 <table border="1" data-bbox="674 918 1019 1041"> <thead> <tr> <th>OSC FREQUENCY</th> <th>S-φSW</th> <th>S-1SW</th> </tr> </thead> <tbody> <tr> <td>800HZ</td> <td>ON</td> <td>ON</td> </tr> <tr> <td>7.5K</td> <td>OFF</td> <td>ON</td> </tr> <tr> <td>15K</td> <td>ON</td> <td>OFF</td> </tr> </tbody> </table>	OSC FREQUENCY	S-φSW	S-1SW	800HZ	ON	ON	7.5K	OFF	ON	15K	ON	OFF	<p>TEST CN (CB8001) にショートコネクター接続</p> <p>TEST S8001, 8002をテスト側にスイッチ TP8002より800Hz 波形モニター</p> <p>VR8002により56m(1000mV-25db)に調整する。</p> <p>※チューニングレベルは、ドルビーレベルの-25dBを基準とする。</p>  <p>TEST CNの接続により800Hz 7KHz、15KHzと周波形が変化する。</p>
OSC FREQUENCY	S-φSW	S-1SW															
800HZ	ON	ON															
7.5K	OFF	ON															
15K	ON	OFF															
b)A/D CONV GAN 調整	STOP	VR8003	TP8003		<p>A/D IN 時間軸の調整 (仮)</p>   <p>-100Vに調整</p> <p>※可変範囲は、OFF SET が正常値の場合に-50~-200mV位で有る。</p>												
c)A/D CONV オフセット	STOP	VR8004	TP8007 TP8002		<p>TP8002をGNDしたとき-8 mVDCとなる様に調整する。</p> <p>〔信号 ON で-100mV 調整されている〕とき</p>  												

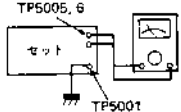
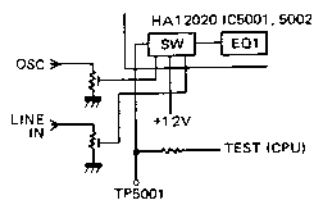
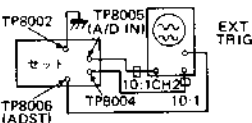
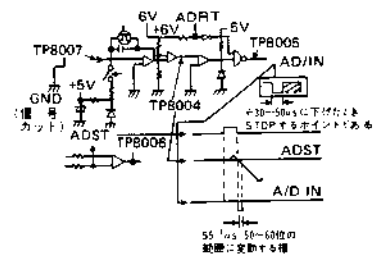
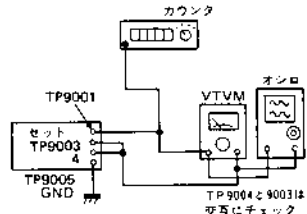
ステップ名称	セットの状態	調整位置	テストポイント	接続方法	手順・テストテープ・規格等
					可変範囲は+40~-40mV位で有る。OSC ONの時-160mVで有る……GAIN調整が正常値の場合
d)AUTO EQ TEST OSC 選択 (内臓 OSC)	REC/PLAY	VR5003 5004	TP5005 5006 TP5001		内部 OSC 選択のため TP 5001を GND する。 (これによって12020内の SW にて TEST に 切替え) VR5003, 5004にて5.6mV (100mV-25dB)に調整 
E)A/D IN 調整 (無信号時の A/D-IN 調整) OFF SET	CTS-ON	VR8004	TP8002 TP8004 TP8005 ADST (TP8006)	 オシロは EXT TRG LEVEL を調整して、CTS -ON 時の ADST 信号によりトリガーされる 様にする。 INPUT をショートして、オシロの水平線を中 心に合わせる。 その後 DC にスイッチ、レンジは 2 V 掃引時 間は20μS ※測定は10 : 1 ニブループを用いて他の測定 器は接続しない。	 TP8002をショート (無信号) する。 CTS-ONで VR8004でA/D IN TIME を50~60μS に合 わせる (オシロ観測) ※30μS まで減少させると停止する。
F)A/D CONV GAIN 調整	CTS -ON	VR8003	TEST SW S8001 } ON S8002 }	E)と同様にセットし、レンジは 2 V、掃引時間 は 1 ms	VR8003でA/D IN TIME を 5 ms に合 わせる。 (オシロ観測) ※内臓 OSC ON (TP8002ショート→オープ ン)
G)OFF SET GAIN の 再認識					E)にもどって確認、ずれている場合再調して GAIN 再調整する。 どちらも良くなるまで、くり返す。
21. HEAD ERASER の調整	POWER -OFF POWER -ON (くり返して チェック)	VR9001 9002	TP9001 TP9005 TP9003 TP9004	Eraser P.C.B はヘッドケーブル及びブリア ンプと接続して行なう。  ※調整 Power-ON 直後に行なう (ラインで はエージング放置後 Power-ON して調整)	TP9005を GND したとき TP9001より消磁波 形を観測 VR9001にてレベル調整 ……3.15 (+10dBV) VR9002にて周波数調整 ……880±1 Hz、レベル、周波数とも上り直 になるまで交互に調整する。 Power-Offして再び Power-ONするとリ レー9001が ON する。(カチツと音がする) こ のとき TP9003 (又は9004) より波形とレベル を測定する。 Power-ON 直後、消磁波形スタート……約 1.35V まもなく波形収束が始まり、波形が小さ なる。しばらくしてリレーが切れる。(音がする) この観測を数回くり返して見る。波形の収束 が終わらないうちにリレーが切れたり、波形の 発生がない等の異常がないかチェック。

Destination's Parts List

Symbol No.	Description	FR Mecha		FD Mechanism		
		J	J	UP	AK	AG
		Japan	Japan	Canada	Europe	England
		100V	100V	120V	Other 220V	Australia 240V
10	Chassis, Bottom	27D50694F03	27D50694F03	27D50694F03	27D50694F04	27D50694F04
13	Scr, T-Tite 4x8	03S44205G09	03S44205G09	None Use	None Use	None Use
19	Stopper, Cord	43B41625J01	43B41625J01	43B41625J01	43B41625J02	43B41625J04
37	Ass'y, Control PCB	01V59500F91	01V63500F37	01V63500F37	01V63500F37	01V63500F37
55	Cover, Rear	15D58657F01	15D58657F01	15D58657F03	15D58657F03	15D58657F03
57	Ass'y, Mother PCB	01V59500F17	01V63500F35	01V63200F24	01V63200F24	01V63200F24
65	Bkt, Trans	07A61182F01	07A61182F01	None Use	None Use	None Use
66	Trans, Power	25T58732F01	25T58732F01	-----	-----	-----
67	Plug, AC Cord	28T41871U01	28T41871U01	28T40916U01	28T50179F03	28T55003F02
68	Terminal, Sensor	29A58768F01	29A58768F01	None Use	None Use	None Use
	Housing, Sensor	15B58781F01	15B58781F01	None Use	None Use	None Use
69	Lamp, Neon	65T61618F01	65T61618F01	None Use	None Use	None Use
71	SW, Select	None Use	None Use	40T40705T04	40T40705T04	40T40705F04
72	Bkt, SW	None Use	None Use	07A61716F01	07A61716F01	07A61716F01
76	Bkt, Front	07C52106F01	07C61799F01	07C61799F01	07C61799F01	07C61799F01
89	Trans, Power	-----	-----	25T61339F01	25T61339F01	25T61339F01
90	Label, Select	None Use	None Use	54A40672U01	54A40672U01	54A40672U01
96	Scr, Mch M4x8	-----	-----	03S52360F14	03S52360F14	03S52360F14
110	Cover, Mecha	15B50731F01	15B61798F01	15B61798F01	15B61798F01	15B61798F01
111	Scr, T-Tite	03S40012G18	03S44205G41	03S44205G41	03S44205G41	03S44205G41
113	Lens, Dust Cover	61A50736F01	None Use	None Use	None Use	None Use
115	Scr, Tpg M2x5	03S40012G58	None Use	None Use	None Use	None Use
117	LED, Green TLUG 163	48T52606F01	None Use	None Use	None Use	None Use
118	Label, Reflector	54A55965F01	None Use	None Use	None Use	None Use
186	Cassette Deck	01U59000F48	01U62000F36	01U62000F36	01U62000F36	01U62000F36
197	LED SLF	None Use	48T60878F01	48T60878F01	48T60878F01	48T60878F01
306	Owner's Manual	68R58780F01	68R58780F01	68R61721F01	68R61721F01	68R61721F01
F1002, 1003	Fuse	None Use	None Use	65T42077U15	65T42077U15	65T42077J15
F1006	Fuse	65T57086F04	65T57086F04	65T42077U16	65T42077U16	65T42077J16
PS2001, 2002	Posistor	None Use	None Use	48T56034F01	48T56034F01	48T56034F01
TH5001	Termister	None Use	48T57369F15	48T57369F15	48T57369F15	48T57369F15
C1021	Capacitor	23T55493F01	23T58450F02	23T58450F02	23T58450F02	23T58450F02
R2015, 2016	Resistor	06S44593P49	06S44593P49	06S44593P54	06S44593P54	06S44593P54
R2053, 2054	Resistor	None Use	None Use	06S44593P41	06S44593P41	06S44593P41
ZD6004	Diode, Zener	48T40059U26	48T40059U13	48T40059U13	48T40059U13	48T40059U13
ZD6005	Diode, Zener	48T40150U28	48T40150U22	48T40150U22	48T40150U22	48T40150U22
ZD6006	Diode, Zener	48T40150U49	48T40059U31	48T40059U31	48T40059U31	48T40059U31
D6015	Diode	None Use	48T58583F01	48T58583F01	48T58583F01	48T58583F01
R6002	Res, Alloy	51T52333F02	51T52333F07	51T52333F07	51T52333F07	51T52333F07

Packing Material Parts List

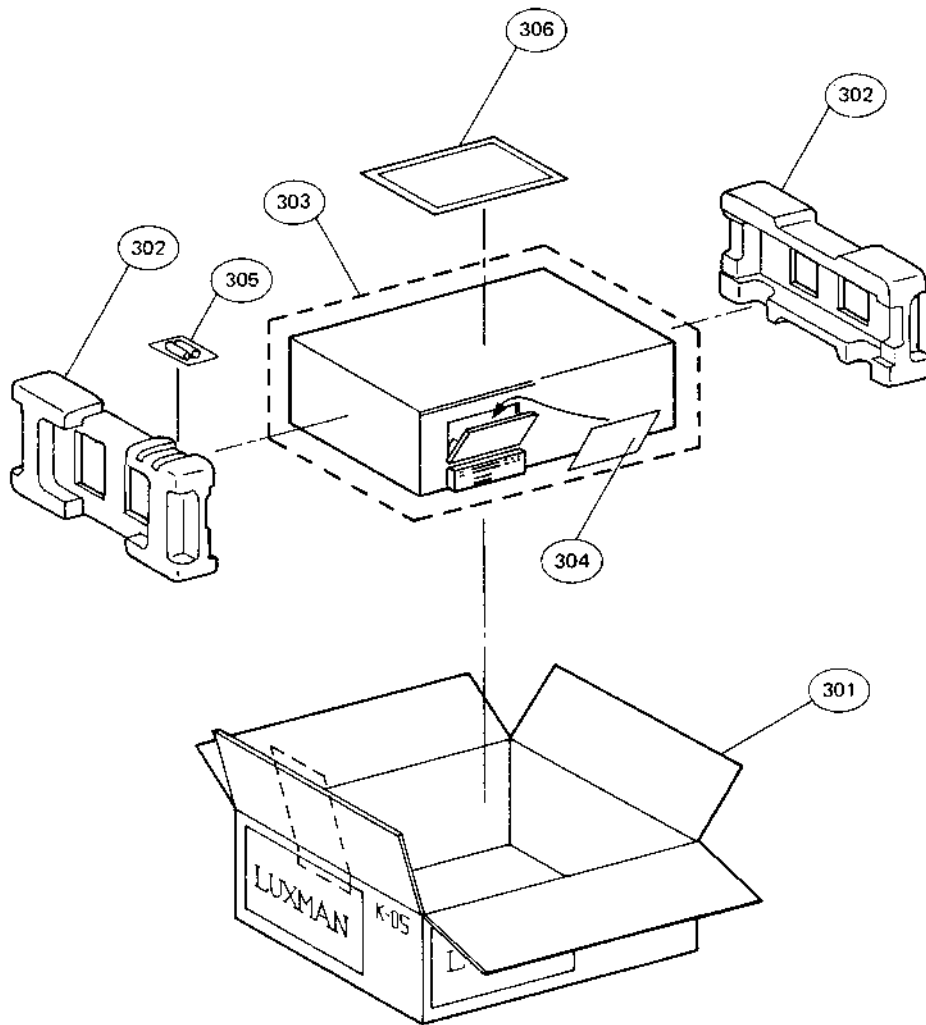

Packing Material Parts List

Index	Symbol No.	Stock No.	Description	Remarks
	301	56C53420F50	Carton, Packing	
	302	56D60007F01	Tray, Packing	
	303	56B40442T13	Packing Front Frame	
	304	56B40442T11	Packing Front Frame	
	305	60T58064F01	Battery, SUM-3"Fuji"	
	306	68R61721F01	Owner's Manual ME0260	UP, AK, AG
	306	68R58780F01	Owner's Manual MA0170	J

Accessory Parts List

Index	Symbol No.	Stock No.	Description	Remarks
		01A60803F01	Cleaning Set	
		01R60802F01	Silicon Cloth	
		28T58909F01	Plug, Audio Cable	
		56R57512F01	Envelope (XC1030)	
		68R57510F02	Card Warranty	J
		68R57511F02	List Service station	J

Exploded View(1)

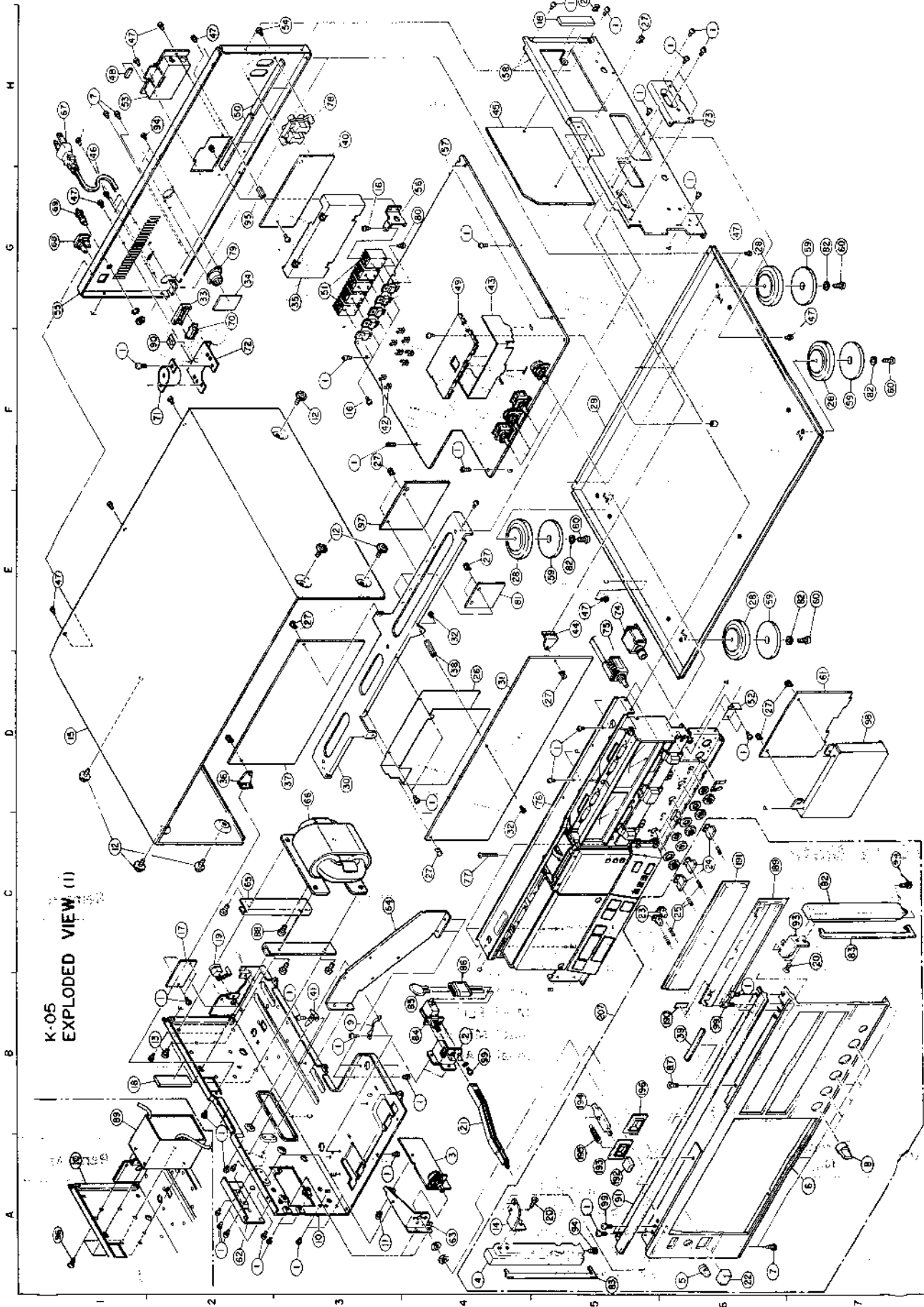

K-05
EXPLODED VIEW (1)

K-05

Exploded View Parts List (1)

Index	Symbol No.	Stock No.	Description	Remarks
A2, A3	1	03A44642J03	Screw, T-Tite M3X5	
B4	2	07A52103F01	Bracket, Switch & Volume	
A4	3	01V59500F97	Ass'y PCB, Pitch Control	
A4	4	64B58645F01	Panel, Side(L)	
A6	5	36A47129F06	Knob, Bias	
B6	6	64D58655F01	Panel, Front	
A6, H1	7	03S44205G38	Screw, T-Tite M3X6	
A7	8	36A58772F01	Knob, Control	
A3	10	27D50694F04	Chassis, Bottom	AK, AG J, UP
		27D50694F03	Chassis, Bottom	
A3	11	05B41635J03	Rivet, Push	
C1, E3	12	03S40036U01	Screw, T-Tite M4X8	J
B2	13	03S44205G09	Screw, T-Tite M4X8	
A4	14	07A58638F01	Bracket, Side(L)	
D1	15	15D58656F01	Cover, Top	
F3, G3	16	03A44642J02	Screw, T-Tite M3X8	
C2	17	01V59500F95	Ass'y Senser, Line	
B1, H5	18	75A42565P08	Cushion, Rubber	
C2	19	43B41625J02	Support, Cord	AK AG J, UP
		43B41625J04	Support, Cord	
		43B41625J01	Stopper, Cord	
A5, C7	20	03S40011G41	Screw, MCH M3X6 Flat	
B4	21	45B44337F01	Lever, Knob	
A6	22	36A45460F06	Knob, Power	
C5	23	36A47374F05	Knob, Push"S"	
C6	24	36A47373F04	Knob, Push"L"	
C6	25	41A41324F01	Spring, Push	
D4	26	26B56943F01	Shield, Dolby	
C3, D2	27	05B41635J02	Rivet, Push	
E4, E6	28	01A57058F02	Ass'y Trannieg	
F5	29	15D50708F02	Cover, Bottom	
D3	30	07C50713F01	Bracket, Panel	
D4	31	01V59500F92	Ass'y PCB, Dolby	
C4, E4	32	03C40014G18	Screw, MCH M2.6X6	
G2	33	43A44685F01	Spacer, Switch	
G2	34	84E58676F04	P. C. B, Remote	
G3	35	26B56945F01	Shield, Ex Panel	
D2	36	07A57334F01	Bracket, Panel L	
D3	37	01V59500F91	Ass'y PCB, Control	FR FD
		01V63500F37	Ass'y PCB, Control	
D4	38	47A57335F01	Shaft, Panel	
B6	39	75A42565P09	Cushion, Rubber	
H3	40	84D58677F04	P. C. B, Phono Plate	
F3	42	09T45548F01	Fuse Holder	
G4	43	26B56946F01	Shield, Pre Amp	
E5	44	07A57334F02	Bracket, Panel R	
H4	45	01V59500F93	Ass'y PCB, REC Equalizer	
H1	46	03S43997P88	Screw, MCH M2X6	
E1, E5	47	03S44205G38	Screw, T-Tite M3X6	
H1	48	75A56670F01	Cushion, Frame	
G4	49	26B56991F01	Shield, Preamp	
H2	50	43A57514F01	Spacer, PCB	
G3	51	07T56351F01	Heat Sink, IC1625MT	
D6	52	41A58642F01	Spring, Earth	
H1	53	15B50733F01	Case, Battery	
H3	54	03S40012G41	Screw, Tapping M3X8	

K-05

Index	Symbol No.	Stock No.	Description	Remarks
G1	55	15D58657F03	Cover, Rear	UP, AK, AG
		15D58657F01	Cover, Rear	J
G4	56	07A57333F01	Bracket, Heat Sink	
H4	57	01V63200F24	Ass'y PCB Mother	UP, AK, AG
		01V59500F87	Ass'y PCB Mother	FR
		01V63500F35	Ass'y PCB Mother	FDJ
H4	58	27C50697F03	Chassis, Side	
E5, E6	59	75A53282F01	Pad, Trannleg	
E5, E7	60	03S44205G52	Screw, T-Tite M4X14 Blk	
D7	61	01V59600F11	Ass'y PCB, Auto Erase	
A2	62	07A58640F01	Bracket, Panel(L)	
A4	63	07B58648F01	Bracket, Volume	
C3	64	07B58392F01	Support, Chassis	
C2	65	07A61182F01	Bracket, Trans	J
D3	66	25T58732F01	Trans Power	J
H1	67	28T50179F03	AC Cord	AK
		28T55003F02	AC Cord	AG
		28T40916U01	Plug, AC Cord	UP
		28T41871U01	Plug, AC Cord	J
G1	68	15B58781F01	Housing, Sensor	J
		29A58768F01	Terminal Senser	J
G1	69	65T61618F01	Lamp, Neon	J
G2	70	40T50262F01	Switch, Slide [50/60Hz]	
	71	40T40705T04	Switch Select	UP, AK, AG
	72	07A61716F01	Bracket, Select Switch	UP, AK, AG
H6	73	07A58641F01	Bracket, Panel(R)	
E5	74	09T45549F12	Jack Mic 6.3 (Metal)	
E5	75	40T58736F01	Switch, Rotary FLEX SBU [NR SELECT]	
F2	76	07C52106F01	Bracket, Front	FR
		07C61799F01	Bracket, Front	FD
C7	77	03S44205G56	Screw, T-Tite M3X25	
H3	78	09T58763F01	Plate, Phono 4P AU	
G2	79	09T53104F01	Socket, Din 8P	
G4	80	03C40014G10	Screw, MCH M3X8	
E4	81	01V59300F76	Ass'y PCB, Pulse OSC	
E5, E7	82	04S40072G08	Washer, Tooth Lock	
A5	83	43A58643F01	Spacer, Side	
B4	84	40T45561F02	Switch Power (SDLIP)	
B4	85	08T57437F09	Capacitor (Ac) 0.01uF	
C4	86	43T53136F01	Bushing, Capacitor TP150-301	
B6	87	03S40012G26	Screw, Tapping M3X6 Flat	
C2	88	03S52360F14	Screw, MCH (M4X8 Fit)	
	89	25T61339F01	Trans Power	UP, AK, AG
	90	54A40672U01	Label, Select	UP, AK, AG
A5	91	64C58651F01	Panel, Top	
C6	92	64B58646F01	Panel, Side(R)	
C7	93	07A58639F01	Bracket, Side(R)	
A5, C7	94	03S40011G91	Screw, MCH M2.6X5 Bind	
G2	95	47A60048F01	Shaft, Panel	
	96	03S52360F14	Screw, MCH (M4X8 Fit)	UP, AK, AG
E3	97	01V59500F90	Ass'y PCB, NR Switch	
D7	98	26B58647F01	Shield, PCB	
A5, B4	99	03C40014G09	Screw, MCH M3X5	
C6	189	07C50696F02	Frame, Switch & Volume	
B6	190	75A42565P22	Cushion, Rubber	
C6	191	61A50716F02	Crystal, Meter	
A5	192	36A45474F06	Knob, Eject	
A5	193	07A45558F02	Frame, Eject	

K-05

Index	Symbol No.	Stock No.	Description	Remarks
B5	194	45A50719F01	Lever, Eject	
A5	195	41A45559F03	Spring, Eject	
B5	196	07A45557F03	Frame, Power	
B5	207	01V59600F13	Ass'y Panel, Front	
C7	208	43A58643F02	Spacer, Side(R)	

Exploded View(2)

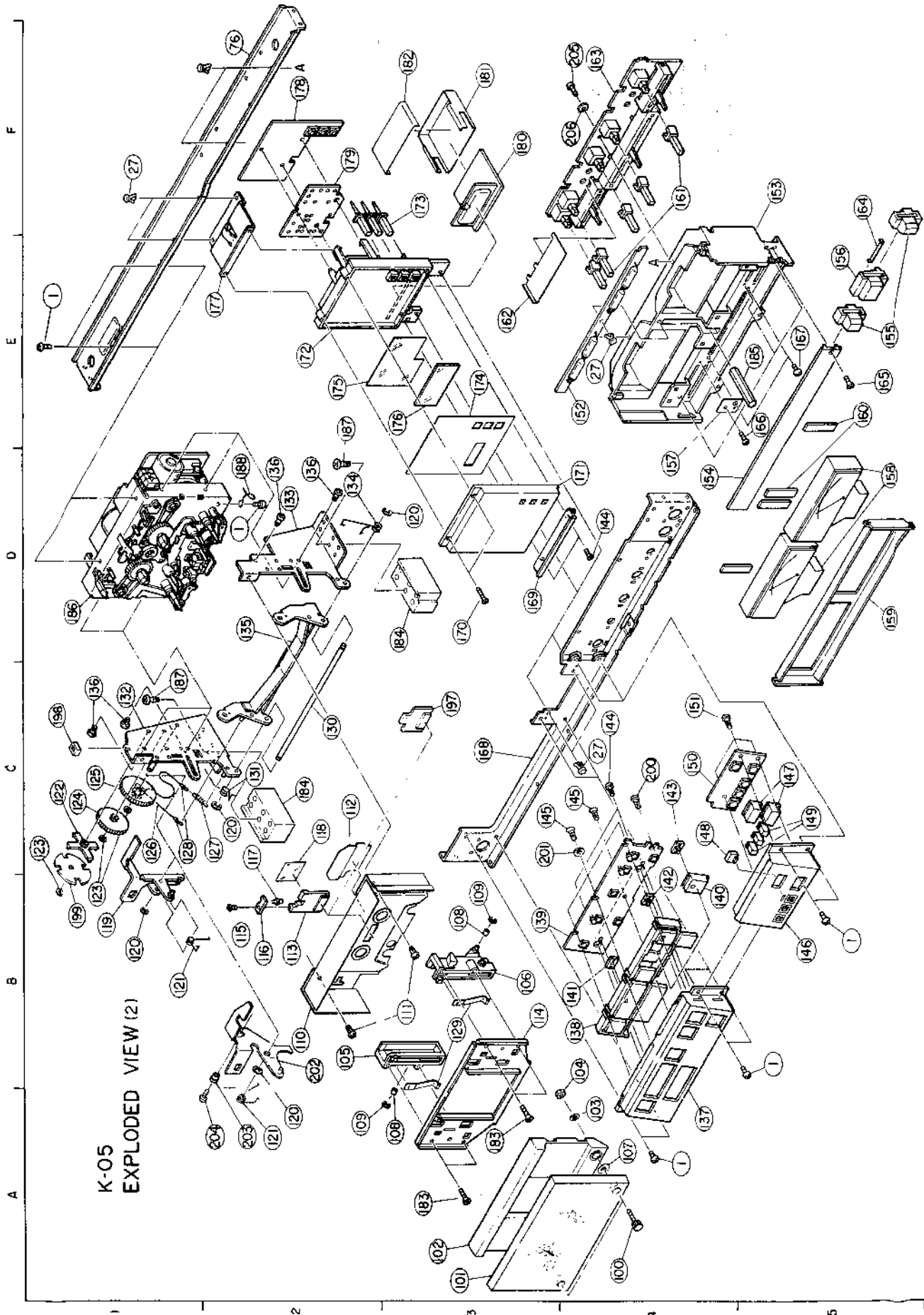

K-05
EXPLODED VIEW(2)

K-05

Exploded View Parts List (2)

Index	Symbol No.	Stock No.	Description	Remarks
A4, B5	1	03A44642J03	Screw, T-Tite M3×5	
E4	11	05B41635J03	Rivet, Push	
C4, D6	27	05B41635J02	Rivet, Push	
A4	100	03A52134F01	Screw, Special M3×8.5	
A3	101	61A50712F02	Crystal, Door	
A3	102	07C50704F03	Frame, Door	
A4	103	04S40071G11	Washer 3.1×5.9×0.7	
B4	104	02S40000G35	Nut, Hex M3	
B2	105	07B58336F01	Frame, Holder L	
B3	106	07B58337F01	Frame, Holder R	
A4	107	04S40075G11	Washer 3.1×5.4×0.13	
A3, B3	108	43A60304F01	Sleeve, Holder	
A2, B3	109	04C42091G12	Washer "C" 1.2	
B2	110	15B50731F01	Cover, Mechanism	FR
		15B61798F01	Cover, Mechanism	FD
B3	111	03S40012G18	Screw, Tapping M2.6×6	FR
		03S44205G41	Screw, T-Tite M2.6×4	FD
C2	112	26A56994F01	Shield, Head	
B2	113	61A50736F01	Lens Dust Cover	FR
B3	114	07B50711F01	Bracket, Cassette	
B2	115	03S40012G58	Screw, Tapping M2×5	FR
B2	116	84E58676F05	P.C.B, LED	
C2	117	48T52606F01	LED GREEN TLUG 163	FR
C2	118	54A55965F01	Label, Reflector	FR
B1	119	45B50732F01	Lever Lock	
B1, C2	120	04C42091G04	Washer "C" 3.0	
A2	121	41A62693F01	Spring Lock	FD
B1	121	41A50738F01	Spring Lock	FR
C1	122	44A53019F01	Gear, Damper C	
B1, C1	123	04A41345P01	Washer 1.2×3.5×0.25	
C1	124	44A52924F01	Gear, Damper B	
C1	125	44A52923F01	Gear, Damper A	
C1	126	30S43803G05	Dial Cord	
C2	127	41A60285F01	Spring, Damper	
C1	128	05A44852G02	Eyelet	
B3	129	41A58335F01	Spring, C Pack	
C2	130	47A50720F01	Shaft, Deck	FR
		47A50720F02	Shaft, Deck	FD
C2	131	41A50740F01	Spring, C Lever	
C1	132	01B60948F01	Ass'y, Deck Bracket L	FD
		07C50714F01	Bracket, Deck L	FR
D2	133	07C50715F01	Bracket, Deck R	FR
		07C50715F02	Bracket, Deck R	FD
D2	135	45B50707F01	Lever, Cassette	FR
		45B50707F02	Lever, Cassette	FD
C1, D2	136	03S40012G18	Screw, Tapping M2.6×6	
A4	137	07D58654F01	Frame, Control(A)	
B4	138	36C58652F01	Knob, Logic Control	
B3	139	01V59600F04	Ass'y PCB, Key Switch	
B4	140	36A52475F01	Knob, Rec	
B4	141	61A52484F02	Lens Indicator Play	
B4	142	61A52484F01	Lens Indicator	
C4	143	61A52484F03	Lens Indicator	
C4, D4	144	03S40012G78	Screw, Tapping M2×6	
C3, C4	145	03S40012G72	Screw, Tapping M2×10 Flat	
B5	146	07C58650F01	Frame, Control(B)	

K-05

Index	Symbol No.	Stock No.	Description	Remarks
C5	147	36A50729F01	Knob, Cassette Control	
C4	148	61B50702F02	Lens Indicator	
C5	149	36A50728F01	Knob, Memory	
C4	150	01V59600F05	Ass'y Memory Key	
C4	151	03S40012G63	Screw, Tapping M2×8	
E4	152	01V59500F99	Ass'y PCB, Lamp	
F5	153	07C50698F01	Frame, Meter	
D4	154	64A50722F02	Panel, Side Volume	
E5	155	36A55396F02	Knob, Slide Volume	
E5	156	36A52099F02	Knob, Slide	
D4	157	26A58795F01	Shield, Meter Volume	
D5	158	72T50769F02	Meter, Level	
D5	159	64B50710F02	Plate, Meter	
E5	160	75A56279F01	Cushion, Meter	
F4	161	45A50724F01	Lever, Push Switch	
E3	162	26A57520F01	Shield, Meter	
F4	163	01V59600F01	Ass'y PCB, Volume & Switch	
F5	164	41A58416F01	Spring, Knob	
E5	165	03S40012G63	Screw, Tapping M2×8	
E5	166	03S43997P33	Screw, MCH M2×6	
E5	167	03S40011G99	Screw, MCH M3×5	
C3	168	27C58653F01	Chassis, Front	
D3	169	07A52138F01	Bracket, Frame L	
D3	170	03S52360F02	Screw, MCH M2×12	
D4	171	61B50718F02	Crystal, Counter	
E2	172	07C50703F01	Frame, Indicator	
F3	173	36A50727F01	Knob, Start	
E3	174	61A50717F02	Crystal, Switch	
E2	175	61A50781F01	Film, Indicator	
E3	176	61A57424F02	Crystal, Filter	
E2	177	07A52137F01	Bracket, Frame U	
F2	178	01V59600F03	Ass'y PCB, LED & Switch	
F2	179	07A52424F01	Support, LED	
F3	180	65T47743F01	FL Counter	
F3	181	26B56944F01	Shield, Counter	
F3	182	26B56944F02	Shield, Counter	
A3	183	03S40012G48	Screw, Tapping M3×6	
C2, D3	184	15A60068F01	Guide, Cassette Deck	
	185	47A60135F01	Shaft, Stopper	
D1	186	01U59000F48	Assy Mechanism FR87E01A	FR
		01U62000F36	Assy Mechanism FD87P030	FD
C1, E2	187	03S40012G28	Screw, Tapping M3×8	
D2	188	42A44230U01	Lug, Wrap Through	
C1	198	75A60759F01	Rubber Eject	FD
B1	199	49A52922F01	Wheel Damper	
C4	200	03S40012G07	Screw, Tapping M2×10	
C3	201	04S40070G33	Washer 2.3×6×0.4	
B2	202	45B60765F01	Arm, Eject	FD
A2	203	43A60764F01	Bush, Arm Eject	FD
A2	204	03S44205G34	Screw, T-Tite M2.6×5	FD
F4	205	03S40011G93	Screw, MCH M3×8	
F4	206	04S40075G13	Washer 3.1×5.4×0.5	

K.05

Exploded View FD Mechanism (New Type)

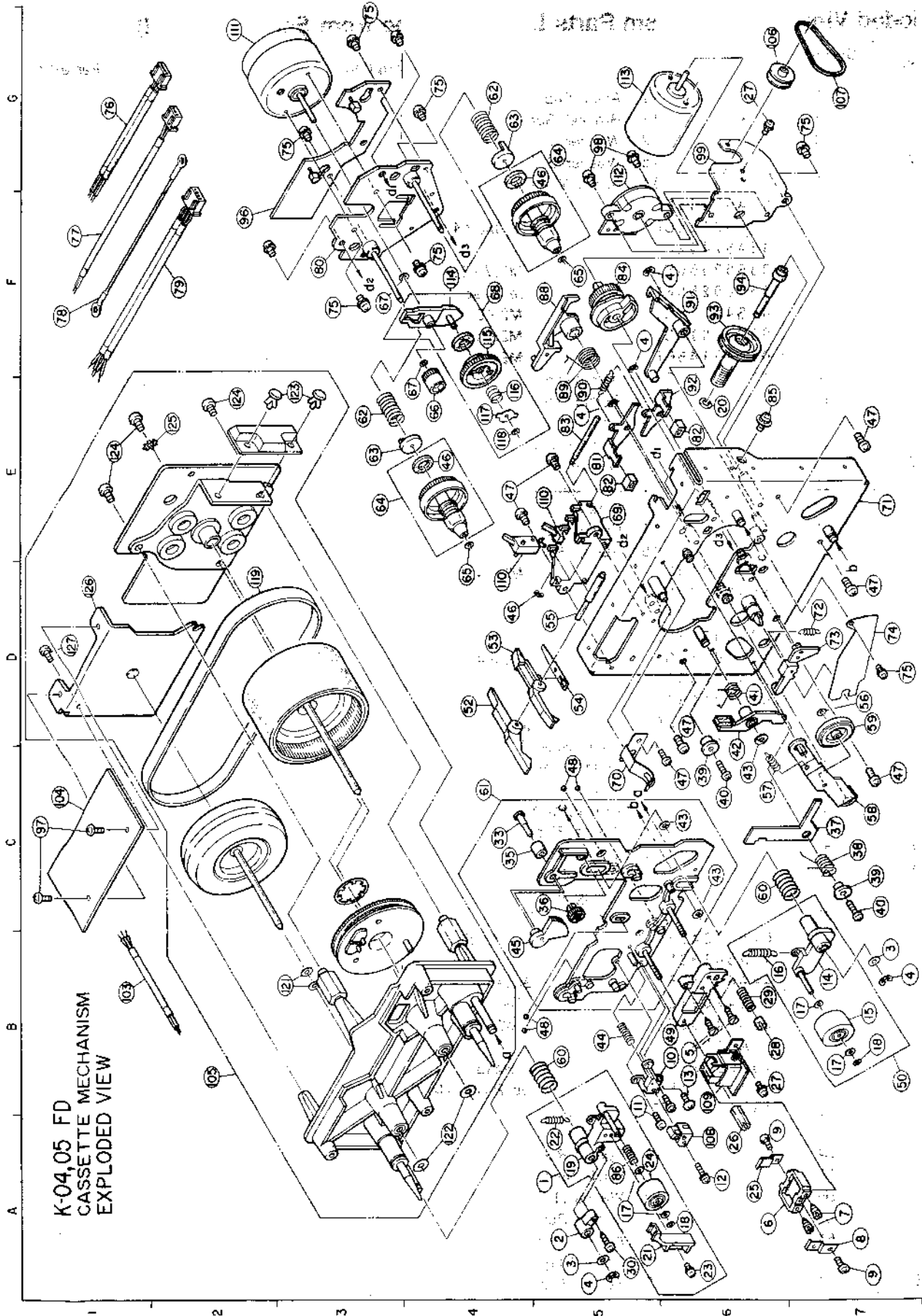

K-04,05 FD
CASSETTE MECHANISM
EXPLODED VIEW

K-05

Exploded View FD Mechanism Parts List (New Type from Serial No. 1251)

Index	Symbol No.	Stock No.	Description	Remarks
A5	1	01A61172F01	Ass'y, Supply Pinchroller	
A5	2	07A60270F01	Bracket, Supply Pinch Adjust	
B7	3	04S40075G12	Washer, 3.1×5.4×0.25	
A5, B7	4	04C42091G05	Washer, C 2.0φ	
B6	5	03A43655U01	Screw, Torque M2×5.5	
A6	6	07A57431F01	Frame, Lifter	
A7	7	03S42155U04	Screw, Set (-) M2×4	
A7	8	45A57432F02	Arm, Lifter	
A6, A7	9	03S52360F16	Screw, MCH M1.7×1.5	
B6	10	15A60255F01	Housing, Erase Head	
B5	11	03S40011G30	Screw, MCH M2×6	
A6	12	03C40014G15	Screw, MCH M2×8	
B6	13	03A43146G01	Screw, MCH M2×6	
B7	14	45A60264F01	Arm, Take up Pinchroller	
B7	15	49A60272F01	Pinchroller	
B6	16	41B60230F04	Spring, Pull	
A5, B7	17	04S40075G07	Washer, 2.1×4×0.5	
A6, B7	18	04C42091G12	Washer, C 1.2φ	
A5	19	45A60265F01	Arm, Supply Pinchroller	
E6	20	04A41345P06	Washer, STW 2.5φ	
A5	21	43A60271F01	Guide, Tape	
A5	22	41B60230F05	Spring, Pull	
A6	23	03C40014G07	Screw, MCH M2×4	
A5	24	49A60272F02	Pinchroller	
A6	25	45A57432F01	Arm, Lifter	
A6	26	02A60263F01	Nut, Azimuth	
B6, G6	27	03C40014G07	Screw, MCH M2×4	
B6	28	02A60838F01	Nut, Stopper	
B6	29	41A60193F03	Spring, Push	
A5	30	03A43655U02	Screw, Torque	
C4	33	47A60262F01	Shaft, Head Azimuth	
C4	35	49A60261F01	Roller, Head Azimuth	
C5	36	44A60258F01	Gear, Head Base—B	
C7	37	45A60797F01	Arm, Eject Stopper	
C7	38	41A60801F01	Spring, Eject Stopper	
C6, C7	39	43A60798F01	Spacer, Screw	
C6, C7	40	03S44205G33	Screw, T-Tite M2.6×8	
D6	41	41A60268F01	Spring, B.T.	
C6	42	45A60266F01	Arm, Back Tension	
C6	43	04A41345P04	Washer, 2.6×6×0.25	
B5	44	41A60193F04	Spring, Push	
B4	45	44A60257F01	Gear, Head Base—A	
D4	46	04C42091G12	Washer, C 1.2φ	
C6, C7	47	03S44205G34	Screw, T-Tite M2.6×5	
B5, C5	48	43A41182P01	Ball, Steel 2	
B6	49	15A60273F01	Housing, R/P Head	
B7	50	01A61171F01	Ass'y, Take up Pinchroller	
D4	52	45A60754F01	Arm, Push	
D4	53	45A60330F01	Arm, Rec	
D5	54	41A60758F01	Spring, Rec	
D5	55	47A62007F01	Shaft, Switch Push	
D7	56	04S40075G02	Washer, 1.7×3.2×0.13	
C6	57	41B60230F02	Spring, Pull	
C7	58	01A60208F01	Ass'y, Lever Play	
D7	59	49A60209F01	Roller, Play Idler	
B5, C6	60	41A60193F05	Spring, Push	

K-05

Index	Symbol No.	Stock No.	Description	Remarks
C4	61	01A60897F01	Ass'y, Head Base	
E3, G4	62	41A60193F01	Spring, Push	
E3, G4	63	49A60192F01	Pulley, Back Tension	
E3, G5	64	01T62785F01	Ass'y, Reel Supply	
D4, F5	65	04S40075G03	Washer, 1.7×3.2×0.25	
E4	66	49A60191F01	Pulley, Reel Motor	
E4, F3	67	04S40075G05	Washer, 2.1×4×0.13	
F4	68	01T60835F01	Ass'y, FF/REW Clutch	
E5	69	07B60755F01	Frame, Switch	
C5	70	41A60222F01	Spring, Cassette	
E7	71	01C60223F01	Ass'y, Chassis Base	
D7	72	41B60230F03	Spring, Pull	
D7	73	45A60217F01	Arm, Pause	
D7	74	41A60269F01	Spring, Ball	
G7, F3	75	03C40014G12	Screw, MCH M2.6×4	
G1	76	01T60761F01	Ass'y, Head Cable P	
F1	77	01T60762F01	Ass'y, Head Cable E	
F1	78	01T62672F01	Ass'y, Erase Wire	
F2	79	01T60761F02	Ass'y, Head Cable R	
F3	80	01A60187F01	Ass'y, Bracket Reel	
E5	81	45A60214F01	Arm, Brake L	
E5, E6	82	75A60213F01	Rubber, Brake	
E5	83	47A60756F01	Shaft, Switch	
F5	84	44B60220F01	Gear, Drive Cam	
E6	85	03C40121T10	Screw, MCH M2.6×5	
A5	86	41A60193F05	Spring, Push	
F5	88	45A60216F01	Arm, FF/REW Release	
E5	89	41A60231F01	Spring, F/R Release	
E5	90	41B60230F01	Spring, Pull	
F6	91	45A60215F01	Lever, Brake	
E6	92	45A60212F01	Arm, Brake R	
F6	93	44A60219F01	Worm, Drive	
F6	94	47A60218F01	Shaft, Worm Gear	
F2	96	01V63300F19	Ass'y, Panel Sensor	
C1	97	03A43852J02	Screw, FT M2.5×5	
G5	98	03C40014G31	Screw, MCH M2.6×10	
G6	99	07A60204F01	Bracket, Drive	
B1	103	30A61681F01	C. W. Shield	
C1	104	84C60794F01	Panel, Wire Ass'y	
B2	105	59T61067F01	Motor, DD	
G6	106	49A60207F01	Pulley, Drive Motor	
G7	107	42A60221F01	Belt, Drive	
A6	108	88T52095F01	Head, Erase	
B6	109	88T58769F01	Head, R/P Combi	
D4, E5	110	40T60329F01	Switch, Leaf	
G2	111	59T60190F01	Motor, Reel	
G5	112	40T60206F01	Switch, Rotary Encoder	
G5	113	59T60205F01	Motor, Drive	
F4	114	45A60195F01	Arm, FF/REW	
F4	115	44A60198F01	Gear, FF/REW	
E4	116	41A60193F01	Spring, Push	
E4	117	04A60199F01	Washer, FF/REW	

Exploded View FR Mechanism (Old Type)

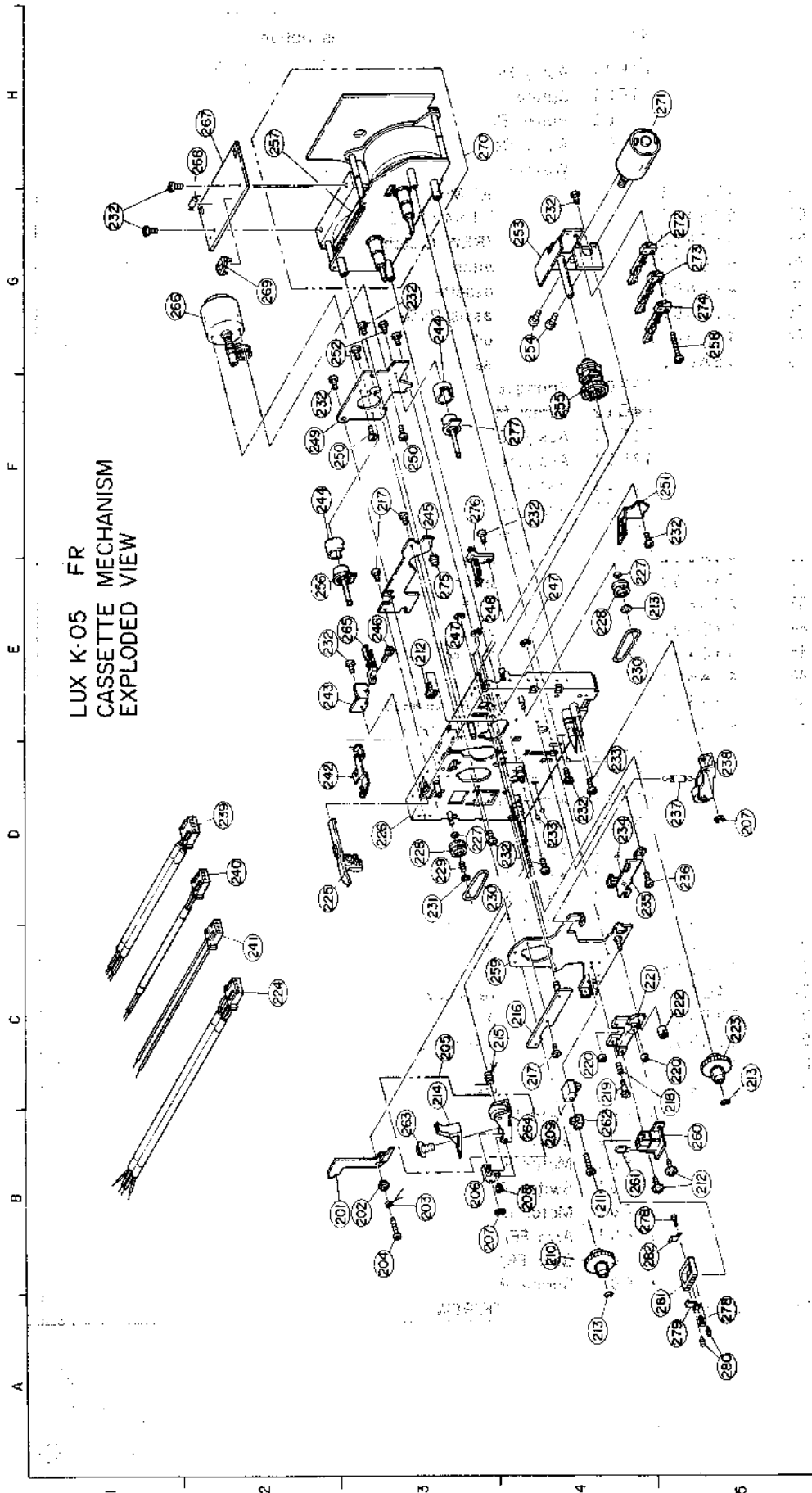

K-05

Exploded View FR Mechanism Parts List (Old Type up to Serial No. 1250)

Index	Symbol No.	Stock No.	Description	Remarks
B2	201		Lock, Lever	
B3	202	43E00049S01	Spacer	
B3	203	41E00050S01	Spring, Pull	
B3	204		Screw, Pan M2.5×10	
C3	205	01E00044S01	Ass'y, Supply Pinchroller	
B3	206	07E00047S01	Support, Pinchroller	
B3, D5	207	04C42091G05	Washer, E M2	
B4	208	03E00109S02	Screw, Set (-) M2×3	
B4	209	46E00026S01	Block, Erase Head	
B4	210	49E00040S01	Reel, Supply	
B4	211	03E00027S01	Screw, M2×20	
B5	212	03C40014G07	Screw, M2×4	
A4, C5	213	04E00062S02	Washer	
C3	214	43E00194S01	Guide, Tape	
C4	215	41E00046S01	Spring, Pinchroller	
C4	216	01E00020S01	Ass'y, Connection Bracket	
C4, F3	217	03E00108S01	Screw, Pan M2.5×4	
C5	218	41E00022S01	Spring, Adjustment	
C4	219	03E00023S01	Screw	
C4, C5	220	03E00109S01	Screw, Set (-) M2×4	
C5	221	46E00021S01	Block, R/P Head	
C5	222	02E00024S01	Nut	
C5	223	49E00039S01	Reel, Take up	
C2	224	01E00056S01	Cable, Connector Rec 4P	
D2	225	45E00052S01	Lever, Record	
D3	226		Ass'y, Chassis Rivet	
D3, E4	227	04E00062S03	Washer	
D3, E4	228	49E00041S01	Pulley	
D3	229	41E00061S01	Spring, Pull	
D3, E4	230	42E00042S01	Belt, Reel	
D3	231	04E00062S01	Washer, Flat	
D4, E2	232	03A43852J02	Screw, Pan M2.5×5	
D4	233	43E00028S01	Ball, Steel M2	
D4	234	43E00028S02	Ball, Steel M3	
D4	235	41E00029S01	Spring, Head Base	
D5	236	03S40011G21	Screw, Pan M3×4	
D5	237	41E00045S01	Spring, Pull	
D5	238	01E00043S01	Ass'y, Pinchroller	
D2	239	01E00057S01	Cable, Connector P/B 4P	
D2	240	01E00058S01	Cable, Connector E 3P	
C2	241	01E00059S01	Cable, Connector Thermistor	
D2	242	41E00033S01	Spring, Cassette Guide	
E2	243		Bracket, Leaf Switch	
F2, G3	244	15E00031S01	Case, Reel	
F3	245	01E00018S01	Ass'y, Sensor PCB	
E3	246		Screw, Pan M2.5×6	
E3, E4	247	04C42091G04	Ring, E M3	
E3	248	04C42091G11	Ring, E M2.5	
F2	249		Bracket, Motor	
F3	250	03S43997P36	Screw, Bind M2.6×3	
F5	251		Guide, Bracket	
G3	252	03E00110S01	Screw, Bind M2.6×4	
G4	253		Ass'y, Pad Bracket	
G4	254	03E00111S01	Screw, Pan M2×3	
F4	255	44E00036S01	Cam, Gear	
E2	256	25E00032S01	Coil, Reel	

K-05

Index	Symbol No.	Stock No.	Description	Remarks
H2	257	42E00112S01	Belt	
G5	258	03E00108S03	Screw, Pan M2.5×20	
C4	259	01E00019S01	Ass'y, Head Base Rivet	
B5	260	88T58769F01	Head, R/P Combi	
B4	261	48E00121S01	Termistor	
B4	262	88T52095F01	Head, Erase	
B3	263		Screw	
B4	264		Pinchroller	
E3	265	40E00054S01	Switch, Leaf	
H2	267	01E00055S01	Ass'y, Terminal PCB	
H2	268	48E00114S01	Diode, S5277B	
G2	269	18E00116S01	Semi VR 20KB	
H3	270	59E00038S01	Ass'y, DD Motor	
H5	271	59E00035S01	Ass'y, Pad Motor	
G5	272	40E00037S01	Switch, Leaf	
G5	273	40E00037S01	Switch, Leaf	
G5	274	40E00037S01	Switch, Leaf	
E3	275	48E00217S01	LED, Sensor	
F3	276	40E00053S01	Switch, Leaf	
F4	277	25E00032S01	Coil, Reel	
A5, B4	278	03S52360F16	Screw, Pan M1.7×1.5	
A5	279	45A57432F01	Arm, Lifter	
A5	280	03S42155U01	Screw, Set (-) M2×5	
A5	281	07A57431F01	Frame, Lifter	
B5	282	45A57432F02	Arm, Lifter	

PCB

Mother PCB

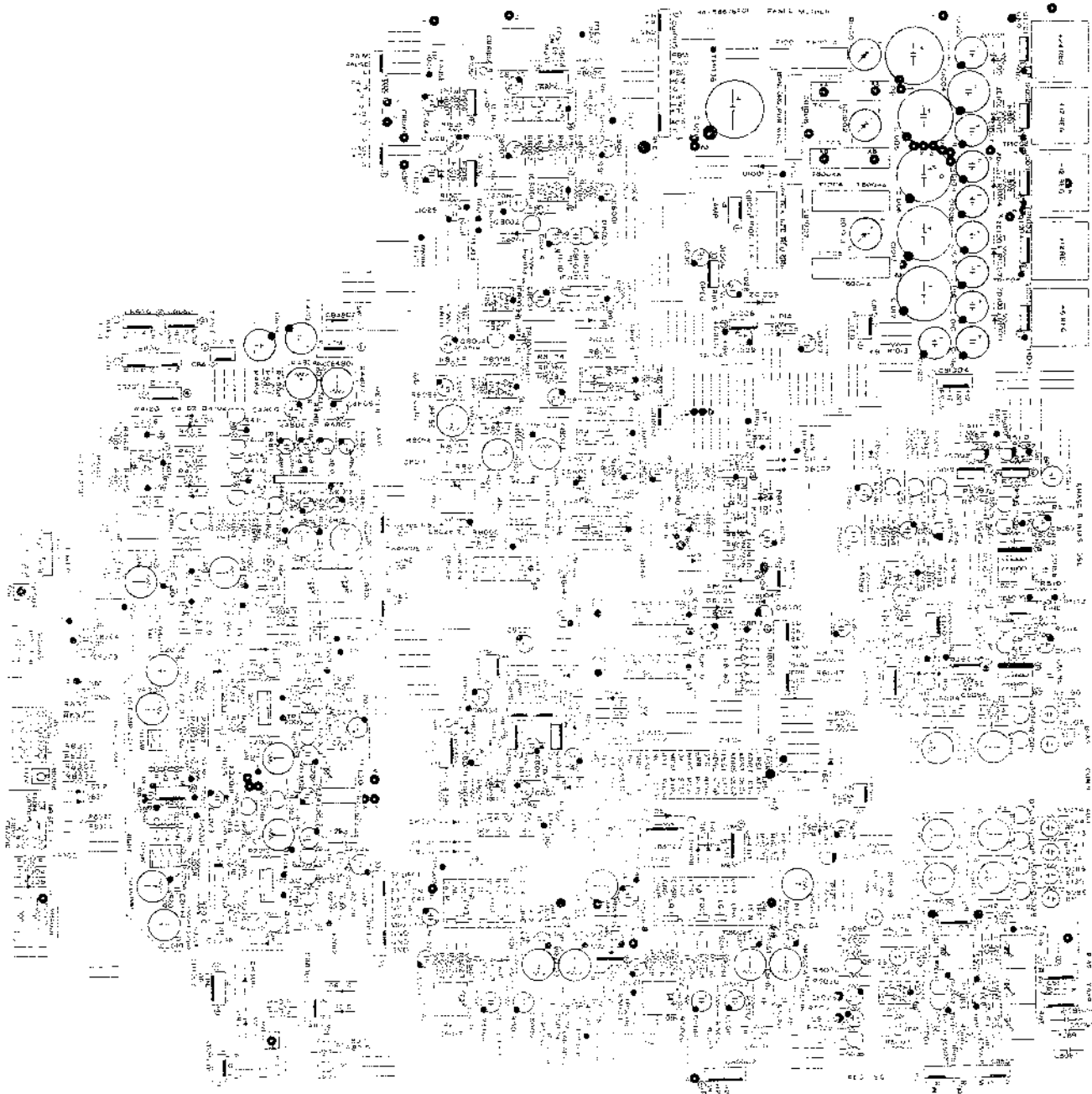

Lamp PCB



Remarks

- Capacitor: El . . . Electrolytic, Ce . . . Ceramic, My . . . Mylar, Mi . . . Mica
Ta . . . Tantalum, Pp . . . Polypropylene, Tf . . .
Resistor: Rd . . . Carbon, Rm . . . Metal Film, Ne . . . Network, Ts . . .

Dolby PCB

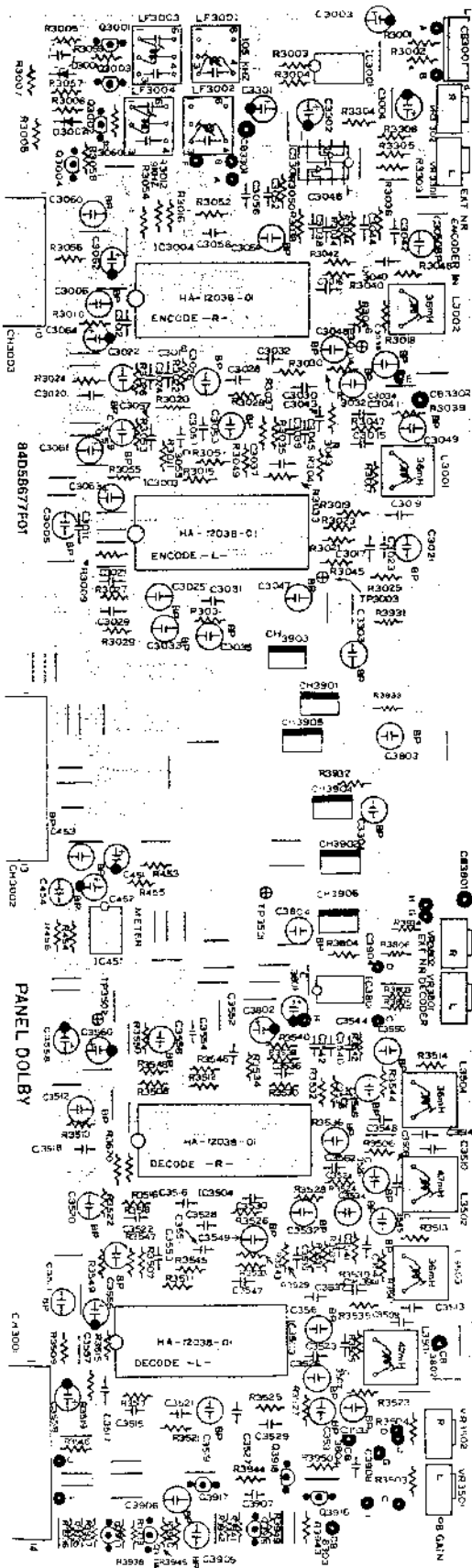

REC EQ PCB

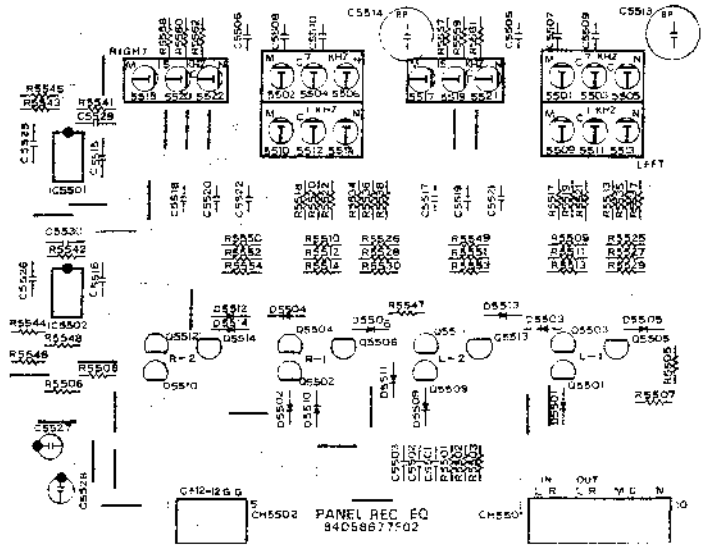

Phone Plate PCB

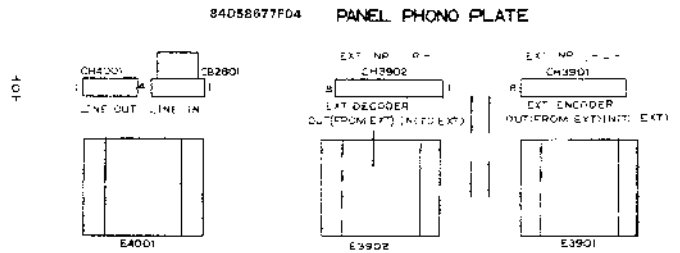

Head Phone PCB

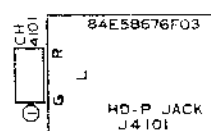

K-OS

Control PCB

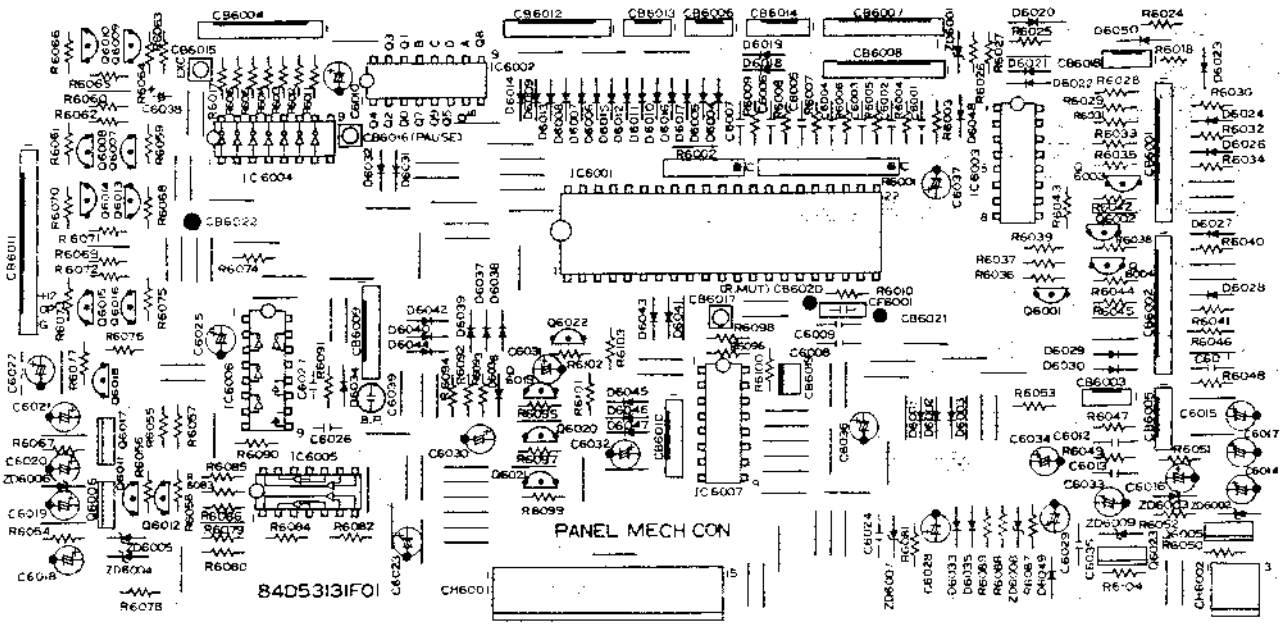

LED & SW PCB

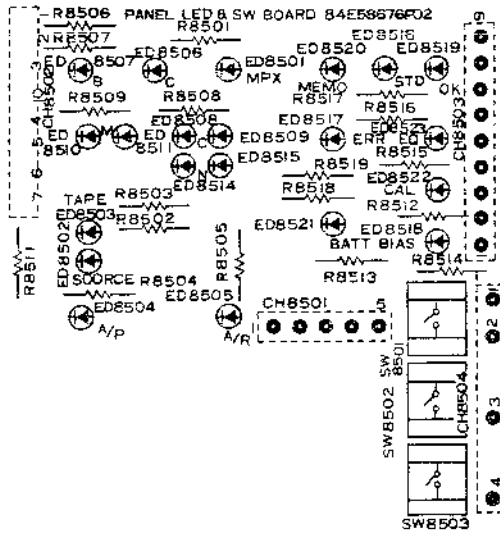

VR & SW PCB

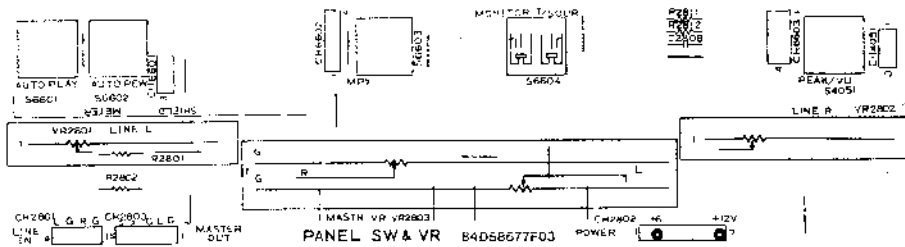

Pitch Control PCB

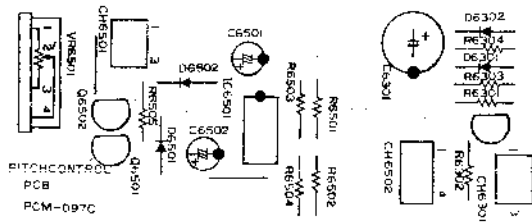

Line Sensor PCB

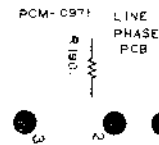

Remote Dindack PCB

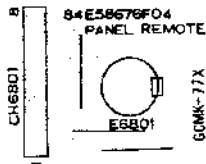

Auto Erase PCB

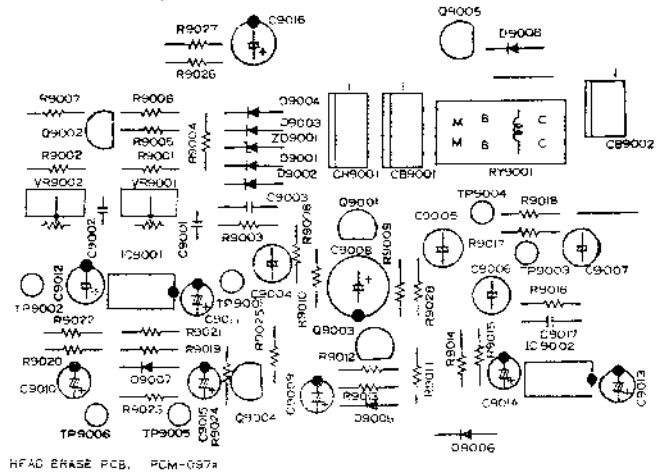

Memory Key PCB

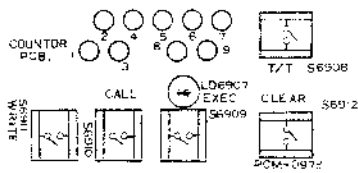

Pulse OSC PCB

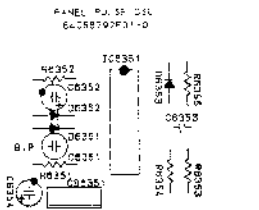

Key Board SW PCB

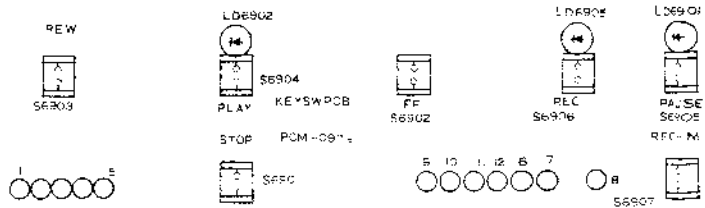

NR SW PCB

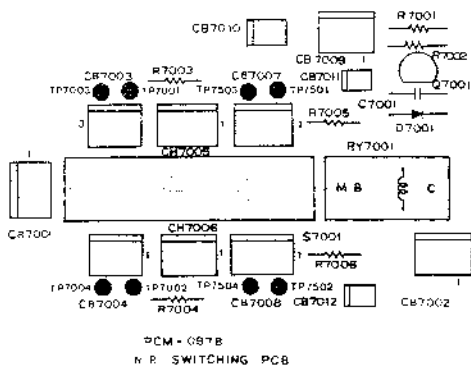

K-05

Mother PCB Parts List

Symbol No.	Stock No.	Description
(Fuse)		
F1001	65T42077U14	Semko T 630MA
F1002	65T42077U15	Semko T 800MA (UP,AK,AG)
F1003	65T42077U15	Semko T 800MA (UP,AK,AG)
F1004	65T42077U15	Semko T 800MA
F1005	65T42077U15	Semko T 800MA
F1006	65T42077U16	Semko T-1A (UP,AK,AG)
F1006	65T57086F04	1A-250V (J)
(Switch)		
S2001	40T52528F01	4P SGK 1042 [PB EQ ADJ]
S2002	40T52528F01	4P SGK 1042 [PB EQ ADJ]
S6801	40T55386F02	SBU 1023 [TIMER]
S8001	40T56373F01	(SSS312) [TEST]
S8002	40T56373F01	(SSS312) [TEST]
S8301	40T55386F02	SBU 1023 [TAPE SELECT]
(Variable Resistor)		
VR2001,2002	18B44064J06	680K 1/2W
VR2003,2004	18B44064J09	1.0K-1/2
VR2007,2008	18C41732G03	4.7K-B
VR4001	18T55388F02	K162-10KB [OUT PUT]
VR4801,4802	18C41732G07	1K-B
VR4803,4804	18C41732G03	4.7K-B
VR5001,5002	18B44064J03	10K-1/2
VR5003,5004	18C41732G05	3.3K
VR5005,5006	18C41732G08	22K
VR5007,5008	18C41732G06	10K-B
VR5011,5012	18C41732G06	10K-B
VR5013,5014	18C41732G08	22K-B
VR5015	18T55389	K-161-5KB [BIAS FINE]
VR8002	18C41732G07	1K-B
VR8003	18B44064J04	47K-1/2
VR8004	18B44064J02	4.7K-1/2W
(Coil)		
L2001,2002	24T51914F01	Trap 4.7mH
L2003,2004	24T51914F02	Trap 10mH
L5001,5002	24T51914F04	Trap 8.2mH
L5003,5004	24T51914F01	Trap 4.7mH
L5005,5006	25T56004F01	OSC
L5007,5008	24T51914F02	Trap 10mH
L8001	24T51914F07	Trap 22mH
(IC)		
IC2001	51T52144F01	NJM072D
IC4101	51T52144F01	NJM072D
IC4801	51T47740F01	TA7332P
IC5001,5002	51T52145F01	HA1202D
IC5003	51T57775F01	TL 072
IC5004	51S43471U02	UPC4558C
IC8001	51S43471U02	UPC4558C
IC8002	51T52154F01	NJM2901N
IC8003	51T57775F01	TL 072
IC8004	51T40941U01	MC14066 BCP
IC8005	51T52154F01	NJM2901N
IC8006	51S43471U02	UPC4558C
IC8007	51T40941U01	MC14066 BCP
IC8008	51T52154F01	NJM2901N
IC8009	51T40242T01	MC14011BCP

Symbol No.	Stock No.	Description
IC8010	51T51781F01	MC14049UB
IC8011	51T52157F01	MC14081
IC8012	51T52158F01	TD62504
IC8013	51T51781F01	MC14049UB
IC8014	51T51993F01	HD44801A48
IC8015	51T40941U01	MC14066 BCP
(Crystal)		
CF8001	91T52156F01	400P
(Transistor & FET)		
Q1001	48T56031F01	2SD1266-P,Q
Q1002	48T56029F01	2SD1276-P,Q
Q1003	48T56028F01	2SB950-P,Q
Q1004	48T56031F01	2SD1266-P,Q
Q1005	48T56029F01	2SD1276-P,Q
Q1006	48T56031F01	2SD1266-P,Q
Q1007	48T56030F01	2SB941-P,Q
Q1008	48T56031F01	2SD1266-P,Q
Q1009	48T56030F01	2SB941-P,Q
Q2001,2002	48T56375F02	2SK270A-GR
Q2003,2004	48T43816F02	2SA798G
Q2007,2008	48T51175F01	2SC1775E
Q2009,2010	48T51175F01	2SC1775E
Q2011,2012	48T52148F01	2SA872 E
Q2013,2014	48S47729F02	2SK117 BL
Q2017	48T51175F01	2SC1775E
Q2018	48T52148F01	2SA872 E
Q4001,4002	48T57305F01	2SD 1302-S,T
Q4101,4102	48T58776F02	2SD438- F
Q4103,4104	48T58775F02	2SB560- F
Q4801,4802	48T51878F01	2SC2878 A,B
Q5002	48T56031F01	2SD1266-P,Q
Q5003,5004	48T57337F01	2SD1330 -DS
Q5005,5006	48T56967F01	2SD1011
Q5009,5010	48T56967F01	2SD1011
Q5011	48T51878F01	2SC2878 A,B
Q5012	48T51878F01	2SC2878 A,B
Q5013	48T51878F01	2SC2878 A,B
Q5014	48T51091F01	2SC2021 R,S
Q5016	48T52122F01	2SK301R
Q5017	48T52122F01	2SK301R
Q5018	48T56031F01	2SD1266-P,Q
Q5019	48T56030F01	2SB941-P,Q
Q5020	48T51091F01	2SC2021 R,S
Q5021	48T56030F01	2SB941-P,Q
Q5022	48T51091F01	2SC2021 R,S
Q5023	48S43525F02	2SC1815-Y
Q5024	48S43525F02	2SC1815-Y
Q5025	48S43525F02	2SC1815-Y
Q5026	48S43525F02	2SC1815-Y
Q5027,5028	48T57337F01	2SD1330 -DS
Q5029,5030	48T56967F01	2SD1011
Q8001	48T52152F01	2SK30A-GR
Q8002	48T52122F01	2SK301R
Q8003	48T56031F01	2SD1266-P,Q
Q8004	48T52122F01	2SK301R
Q8005	48T51091F01	2SC2021 R,S
Q8007	48T51091F01	2SC2021 R,S
Q8008	48T56031F01	2SD1266-P,Q

K-05

Symbol No.	Stock No.	Description
(Diode)		
D1001	48T55186F01	GP10D -AX
D1002	48T55186F01	GP10D -AX
D2001,2002	48T51582F01	MA-150 -AX
D4101,4102	48T51582F01	MA-150 -AX
D4103,4104	48T51582F01	MA-150 -AX
D5003,5004	48T51582F01	MA-150 -AX
D8001	48T51582F01	MA-150 -AX
D8002	48T51582F01	MA-150 -AX
D8003	48T51582F01	MA-150 -AX
D8004	48T51582F01	MA-150 -AX
D8005	48T43982F01	0A95
D8006	48T51582F01	MA-150 -AX
D8007	48T51582F01	MA-150 -AX
D8008	48T51582F01	MA-150 -AX
D8009	48T51582F01	MA-150 -AX
D8010	48T51582F01	MA-150 -AX
D8011	48T51582F01	MA-150 -AX
D8012	48T51582F01	MA-150 -AX
D8013	48T51582F01	MA-150 -AX
D8014	48T51582F01	MA-150 -AX
D8015	48T51582F01	MA-150 -AX
D8016	48T51582F01	MA-150 -AX
D8017	48T51582F01	MA-150 -AX
D8018	48T51582F01	MA-150 -AX
D8019	48T51582F01	MA-150 -AX
D8020	48T51582F01	MA-150 -AX
D8021	48T51582F01	MA-150 -AX
D8022	48T51582F01	MA-150 -AX
D8023	48T51582F01	MA-150 -AX
D8024	48T51582F01	MA-150 -AX
D8025	48T51582F01	MA-150 -AX
D8027	48T51582F01	MA-150 -AX
D8028	48T51582F01	MA-150 -AX
D8030	48T51582F01	MA-150 -AX
D8031	48T51582F01	MA-150 -AX
D8032	48T51582F01	MA-150 -AX
D8033	48T51582F01	MA-150 -AX
D8305	48T51582F01	MA-150 -AX
D8306	48T51582F01	MA-150 -AX
D8307	48T51582F01	MA-150 -AX
D8311	48T51582F01	MA-150 -AX
D8312	48T51582F01	MA-150 -AX
D8315	48T51582F01	MA-150 -AX
D8316	48T51582F01	MA-150 -AX
(Diode,Zener)		
ZD1001	48T52739F93	HZ24 -3 -AX
ZD1002	48T52740F09	HZ12C-3 -AX
ZD1003	48T52740F09	HZ12C-3 -AX
ZD1004	48T52739F73	HZ12B-1 -AX
ZD1005	48T52739F51	HZ 7C-3 -AX
ZD1006	48T52739F54	HZ 9A-3 -AX
ZD1007	48T52739F54	HZ 9A-3 -AX
ZD1008	48T52739F44	HZ 7A-2 -AX
ZD1009	48T52739F44	HZ 7A-2 -AX
ZD2001	48T52741F32	HZ11B-2L -AX
ZD2002	48T52741F32	HZ11B-2L -AX
ZD5001	48T52739F73	HZ12B-1 -AX

Symbol No.	Stock No.	Description
ZD5002	48T52739F42	HZ 6C-3 -AX
ZD8001	48T52739F11	HZ 3B-2 -AX
ZD8002	48T52739F38	HZ 6B-2 -AX
ZD8003	48T52739F14	HZ 3C-2 -AX
ZD8004	48T52739F01	HZ 2B-1 -AX
(Diode,Bridge)		
BD1001	48T50629F01	WL-02
BD1002	48T50629F01	WL-02
BD1003	48T50629F01	WL-02
(Posistor)		
PS2001,2002	48T56034F01	471 (UP,AK,AG)
(Thermistor)		
TH5001	48T57369F15	5KOhm (FD)
(Capacitor)		
C1001	23S41198U67	(Ei) 1000uF 50V
C1002	23S41198U35	(Ei) 100uF 25V
C1004	23S41198U57	(Ei) 470uF 25V
C1005	23S41198U72	(Ei) 2200uF 25V
C1006	23S41198U72	(Ei) 2200uF 25V
C1007	23S41198U56	(Ei) 470uF 16V
C1008	23S41198U56	(Ei) 470uF 16V
C1011	23T43197F11	(Ei) 220uF 16V
C1012	23T43197F11	(Ei) 220uF 16V
C1013	23S41198U72	(Ei) 2200uF 25V
C1014	23S40657F14	(Ei) 100uF 16V
C1016	23S41198U56	(Ei) 470uF 16V
C1017	23S41198U71	(Ei) 2200uF 16V
C1018	23S40657F14	(Ei) 100uF 16V
C1020	23S41198U55	(Ei) 470uF 10V
C1021	23T55493F01	(Ei) 6800uF 25V (FR)
C1021	23T58450F02	(Ei) 10000uF 25V (FR)
C1023	23S41198U27	(Ei) 47uF 16V
C1024	23S41198U27	(Ei) 47uF 16V
C1025	23T43197F10	(Ei) 100uF 16V
C1026	23T43197F10	(Ei) 100uF 16V
C1027	23S40657F10	(Ei) 10uF 16V
C1028	23S40657F10	(Ei) 10uF 16V
C1029	23S40657F10	(Ei) 10uF 16V
C1030	23S40657F10	(Ei) 10uF 16V
C2001,2002	08T55119F18	(Mi) 30pF
C2003,2004	08T55119F28	(Mi) 56pF
C2005,2006	08T55119F30	(Mi) 68pF
C2007,2008	08T55119F32	(Mi) 82pF
C2009,2010	23T41366F14	(Ei) 470uF 10V
C2015,2016	23T61177F01	(Ei) 22uF 16V
C2017,2018	08T52448F35	(Pp) 8200pF
C2019,2020	08S44505P41	(Ce) 220pF
C2021	23T41366F16	(Ei) 10uF 16V
C2022	23T42477F06	(Ei) 10uF 16V
C2023	23T43197F10	(Ei) 100uF 16V
C2024	23T43197F10	(Ei) 100uF 16V
C2025,2025	23T43197F09	(Ei) 47uF 16V
C2027,2028	23T43197F09	(Ei) 47uF 16V
C2029,2030	23T43197F09	(Ei) 47uF 16V
C2031,2032	08S44505P45	(Ce) 470pF
C2033,2034	08T55119F34	(Mi) 100pF
C2035,2036	08T50579F21	(Tf) 0.47uF
C2037,2038	08T50579F21	(Tf) 0.47uF

K-05

Symbol No.	Stock No.	Description
C4103,4104	23T43197F11	(El) 220uF 16V
C4105,4106	08S44505P10	(Ce) 5.6pF
C4107,4108	23S41192U17	(El) 4.7uF 25V
C4803,4804	23S40657F13	(El) 47uF 16V
C4805,4806	23S40657F18	(El) 22uF 25V
C4807,4808	23S41059P22	(Ta) 6.8uF 16V
C4809,4810	23S41059P09	(Ta) 1.5uF 25V
C4851,4852	08S44503P12	(My) 0.0082uF
C5001,5002	23T43197F06	(El) 10uF 16V
C5003	23T40475U14	(El) 10uF 16V
C5004	23T42478F05	(El) 10uF 16V
C5007,5008	23T43197F10	(El) 100uF 16V
C5009,5010	23S41198U34	(El) 100uF 16V
C5011,5012	08T52448F41	(Pp) 15000pF
C5013,5014	23S40657F14	(El) 100uF 16V
C5015,5016	08T40656F09	(My) 4700pF
C5017,5018	08T52448F25	(Pp) 3300pF
C5019,5020	23T43197F03	(El) 2.2uF 50V
C5021,5022	23T58027F01	(El) 10uF 16V
C5025,5026	23T43197F10	(El) 100uF 16V
C5027,5028	23T61177F02	(El) 47uF 16V
C5029,5030	08S44505P45	(Ce) 470pF
C5031,5032	23T41366F16	(El) 10uF 16V
C5035,5036	08S44505P53	(Ce) 2200pF
C5043,5044	23T41366F16	(El) 10uF 16V
C5047,5048	08S44505P52	(Ce) 1800pF
C5049,5050	08S44505P52	(Ce) 1800pF
C5051	23S40657F13	(El) 47uF 16V
C5052	23T43197F09	(El) 47uF 16V
C5053	23T61177F03	(El) 47uF 25V
C5054	08T52448F37	(Pp) 10000pF
C5056	08S44505P61	(Ce) 10000pF
C5057	08T44481F21	(Pp) 0.0022uF
C5058	08T52448F21	(Pp) 2200pF
C5059	08T52448F34	(Pp) 7500pF
C5060	23S41198U09	(El) 4.7uF 50V
C5061	08T52448F25	(Pp) 3300pF
C5062	08T52448F25	(Pp) 3300pF
C5063	08T44481F37	(Pp) 0.010uF
C5064	08T44481F37	(Pp) 0.010uF
C5065	23S41198U15	(El) 22uF 25V
C5066	08T52448F17	(Pp) 1500pF
C5068	08T52448F21	(Pp) 2200pF
C5069	23T61177F03	(El) 47uF 25V
C5070	23T42477F50	(El) 0.10uF 50V
C5071	23T42477F50	(El) 0.10uF 50V
C5073,5074	08S44505P41	(Ce) 220pF
C5075,5076	08T52448F49	(Pp) 33000pF
C5077,5078	08T44481F45	(Pp) 22000pF
C5079,5080	08T50579F25	(Tf) 1.0uF
C5081,5082	08S44505P49	(Ce) 1000pF
C5083,5084	08S44505P40	(Ce) 180pF
C5085,5086	23T41366F16	(El) 10uF 16V
C5087	08S44505P61	(Ce) 10000pF
C5089	08S44505P61	(Ce) 10000pF
C5090	08S44505P61	(Ce) 10000pF
C5091	23T42477F18	(El) 2.2uF 50V
C5093	08S44503P12	(My) 0.0082uF

Symbol No.	Stock No.	Description
C5094	08S44503P12	(My) 0.0082uF
C8001	08T60792F01	(Pp) 0.0039uF
C8002	08T60792F01	(Pp) 0.0039uF
C8003	23T42477F06	(El) 10uF 16V
C8004	23S41059P03	(Ta) 0.22uF 35V
C8005	23S41198U12	(El) 10uF 50V
C8006	23S40657F10	(El) 10uF 16V
C8007	23S40657F10	(El) 10uF 16V
C8008	23T41366F16	(El) 10uF 16V
C8009	23S40657F10	(El) 10uF 16V
C8010	23S40657F10	(El) 10uF 16V
C8011	08S44505P53	(Ce) 2200pF
C8012	08S44505P45	(Ce) 470pF
C8013	23S41059P26	(Ta) 10uF 16V
C8014	23S40657F13	(El) 47uF 16V
C8015	08T44481F49	(Pp) 0.033uF
C8016	08T52448F16	(Pp) 1300pF
C8017	23S40657F10	(El) 10uF 16V
C8018	23S40657F10	(El) 10uF 16V
C8019	08T57851F16	(Tf) 0.18uF
C8020	23S41059P08	(Ta) 1uF 35V
C8021	08T52448F45	(Pp) 22000pF
C8022	23S41198U12	(El) 10uF 50V
C8023	23S40657F10	(El) 10uF 16V
C8024	23S41059P11	(Ta) 2.2uF 16V
C8026	23S40657F10	(El) 10uF 16V
C8027	23S40657F10	(El) 10uF 16V
C8028	23S40657F10	(El) 10uF 16V
C8029	23S40657F18	(El) 22uF 25V
C8030	23S40657F10	(El) 10uF 16V
C8031	23S40657F10	(El) 10uF 16V
C8032	23S40657F10	(El) 10uF 16V
C8033	23S40657F10	(El) 10uF 16V
C8034	23T43197F11	(El) 220uF 16V
C8035	23S40657F10	(El) 10uF 16V
C8036	23S41059P11	(Ta) 2.2uF 16V
C8037	23S40657F10	(El) 10uF 16V
C8038	23S40657F10	(El) 10uF 16V
C8039	08S44505P63	(Ce) 22000pF
C8040	08S44505P63	(Ce) 22000pF
C8042	23S41198U12	(El) 10uF 50V
C8301	23T41366F16	(El) 10uF 16V
C8303	23T41366F16	(El) 10uF 16V
C8304	23T42477F06	(El) 10uF 16V
C8305	23S41192U04	(El) 1uF 50V
C8310	23T41366F16	(El) 10uF 16V
C8311	23T42477F52	(El) 0.22uF 50V
(Resistor)		
R1001	06S44593P69	(Rd) 1.5KΩ 1/4W
R1003	06S44593P60	(Rd) 620Ω 1/4W
R1004	06S44593P60	(Rd) 620Ω 1/4W
R1007	06S44593P63	(Rd) 820Ω 1/4W
R1009	06S44593P58	(Rd) 510Ω 1/4W
R1011	06S44593P61	(Rd) 680Ω 1/4W
R1012	06S44593P61	(Rd) 680Ω 1/4W
R1013	06S44593P43	(Rd) 120Ω 1/4W
R1014	06S44593P65	(Rd) 1KΩ 1/4W
R1015	06S44593P65	(Rd) 1KΩ 1/4W

K-05

Symbol No.	Stock No.	Description
R1501	06S44593P89	(Rd) 10K Ω 1/4W
R1502	06S44593P89	(Rd) 10K Ω 1/4W
R1505	06S44593P72	(Rd) 2K Ω 1/4W
R1506	06S44593P72	(Rd) 2K Ω 1/4W
R2001,2002	06S44593P01	(Rd) 2.2 Ω 1/4W
R2003,2004	06S44594P06	(Rd) 47K Ω 1/4W
R2007,2008	06S44594P14	(Rd) 100K Ω 1/4W
R2009,2010	06S44593P79	(Rd) 3.9K Ω 1/4W
R2011,2012	06S44593P79	(Rd) 3.9K Ω 1/4W
R2013,2014	06S44593P82	(Rd) 5.1K Ω 1/4W
R2015,2016	06S44593P54	(Rd) 360 Ω 1/4W (UP,AK,AG)
R2015,2016	06S44593P49	(Rd) 220 Ω 1/4W (J)
R2017,2018	06S44593P60	(Rd) 620 Ω 1/4W
R2019,2020	06S44593P85	(Rd) 6.8K Ω 1/4W
R2021,2022	06S44593P77	(Rd) 3.3K Ω 1/4W
R2023,2024	06S44593P74	(Rd) 2.4K Ω 1/4W
R2025,2026	06S44593P85	(Rd) 6.8K Ω 1/4W
R2027,2028	06S44593P17	(Rd) 10 Ω 1/4W
R2029,2030	06S44593P17	(Rd) 10 Ω 1/4W
R2031,2032	06S44593P85	(Rd) 6.8K Ω 1/4W
R2033,2034	06S44593P87	(Rd) 8.2K Ω 1/4W
R2035,2036	06S44594P32	(Rd) 560K Ω 1/4W
R2045,2046	06S44593P68	(Rd) 1.3K Ω 1/4W
R2047,2048	06S44594P09	(Rd) 62K Ω 1/4W
R2049,2050	06S44593P33	(Rd) 47 Ω 1/4W
R2051	06T61718F03	(Ts) 309 Ω 1/4W
R2052	06T61718F03	(Ts) 309 Ω 1/4W
R2053,2054	06S44593P41	(Rd) 100 Ω 1/4W (UP,AK,AG)
R4003,4004	06S44593P77	(Rd) 3.3K Ω 1/4W
R4007,4008	06S44593P49	(Rd) 220 Ω 1/4W
R4101,4102	06S44594P13	(Rd) 91K Ω 1/4W
R4103,4104	06S44593P92	(Rd) 13K Ω 1/4W
R4105,4106	06S40150T91	(Rd) 12K Ω 1/4W
R4107,4108	06S44593P89	(Rd) 10K Ω 1/4W
R4109,4110	06S44593P89	(Rd) 10K Ω 1/4W
R4111,4112	06S44593P17	(Rd) 10 Ω 1/4W
R4113,4114	06S44593P17	(Rd) 10 Ω 1/4W
R4119,4120	06S44594P17	(Rd) 130K Ω 1/4W
R4801,4802	06S44594P14	(Rd) 100K Ω 1/4W
R4803,4804	06S44593P65	(Rd) 1K Ω 1/4W
R4805,4806	06S44593P63	(Rd) 820 Ω 1/4W
R4807,4808	06S44593P81	(Rd) 4.7K Ω 1/4W
R4809,4810	06S44593P89	(Rd) 10K Ω 1/4W
R4811,4812	06S44593P47	(Rd) 180 Ω 1/4W
R4813,4814	06S44594P38	(Rd) 1M Ω 1/4W
R4815,4816	06S44594P38	(Rd) 1M Ω 1/4W
R4817,4818	06S44593P97	(Rd) 22K Ω 1/4W
R5001,5002	06S44594P02	(Rd) 33K Ω 1/4W
R5003,5004	06S44594P18	(Rd) 150K Ω 1/4W
R5005,5006	06S44593P97	(Rd) 22K Ω 1/4W
R5007,5008	06S44593P41	(Rd) 100 Ω 1/4W
R5010	06S44593P65	(Rd) 1K Ω 1/4W
R5011,5012	06S44593P69	(Rd) 1.5K Ω 1/4W
R5013,5014	06S44593P83	(Rd) 5.6K Ω 1/4W
R5015,5016	06S44593P83	(Rd) 5.6K Ω 1/4W
R5017,5018	06S44593P89	(Rd) 10K Ω 1/4W
R5019,5020	06S44593P81	(Rd) 4.7K Ω 1/4W
R5021,5022	06S44593P87	(Rd) 8.2K Ω 1/4W

Symbol No.	Stock No.	Description
R5023,5024	06S44593P58	(Rd) 510 Ω 1/4W
R5025,5026	06S44593P87	(Rd) 8.2K Ω 1/4W
R5027,5028	06S44593P89	(Rd) 10K Ω 1/4W
R5029,5030	06S44594P14	(Rd) 100K Ω 1/4W
R5031,5032	06S44593P65	(Rd) 1K Ω 1/4W
R5033,5034	06S44593P79	(Rd) 3.9K Ω 1/4W
R5035,5036	06S44593P65	(Rd) 1K Ω 1/4W
R5051	06S44594P38	(Rd) 1M Ω 1/4W
R5055,5056	06S44594P14	(Rd) 100K Ω 1/4W
R5059,5060	06S44593P60	(Rd) 620 Ω 1/4W
R5061,5062	06S44594P06	(Rd) 47K Ω 1/4W
R5063,5064	06S44593P60	(Rd) 620 Ω 1/4W
R5065,5066	06S44593P89	(Rd) 10K Ω 1/4W
R5073,5074	06S44593P89	(Rd) 10K Ω 1/4W
R5077,5078	06S44593P01	(Rd) 2.2 Ω 1/4W
R5079,5080	06S44593P89	(Rd) 10K Ω 1/4W
R5081	06S44593P89	(Rd) 10K Ω 1/4W
R5082	06S44594P02	(Rd) 33K Ω 1/4W
R5083	06S44593P92	(Rd) 13K Ω 1/4W
R5084	06S44593P81	(Rd) 4.7K Ω 1/4W
R5085	06S44594P35	(Rd) 750K Ω 1/4W
R5086	06S44593P65	(Rd) 1K Ω 1/4W
R5087	06S44593P82	(Rd) 5.1K Ω 1/4W
R5088	06S44593P93	(Rd) 15K Ω 1/4W
R5089	06S44594P08	(Rd) 56K Ω 1/4W
R5090	06S44593P89	(Rd) 10K Ω 1/4W
R5091	06S44593P89	(Rd) 10K Ω 1/4W
R5092	06S44594P06	(Rd) 47K Ω 1/4W
R5094	06S44593P92	(Rd) 13K Ω 1/4W
R5095	06S44593P41	(Rd) 100 Ω 1/4W
R5096	06S44593P51	(Rd) 270 Ω 1/4W
R5097	06S44594P02	(Rd) 33K Ω 1/4W
R5098	06S44593P89	(Rd) 10K Ω 1/4W
R5099	06S44593P89	(Rd) 10K Ω 1/4W
R5100	06S44594P02	(Rd) 33K Ω 1/4W
R5101	06S44594P02	(Rd) 33K Ω 1/4W
R5103	06S44593P54	(Rd) 360 Ω 1/4W
R5104	06S44593P97	(Rd) 22K Ω 1/4W
R5105	06S44593P97	(Rd) 22K Ω 1/4W
R5107	06C43205J01	(Rm) 0.5 Ω 1/2W
R5108	06S44594P06	(Rd) 47K Ω 1/4W
R5109	06S44593P89	(Rd) 10K Ω 1/4W
R5110	06S44594P06	(Rd) 47K Ω 1/4W
R5111	06S44593P89	(Rd) 10K Ω 1/4W
R5112	06S44593P81	(Rd) 4.7K Ω 1/4W
R5113,5114	06S44593P25	(Rd) 22 Ω 1/4W
R5115,5116	06S44593P21	(Rd) 15 Ω 1/4W
R5117,5118	06S44594P10	(Rd) 68K Ω 1/4W
R5119,5120	06S44594P02	(Rd) 33K Ω 1/4W
R5121	06S44593P89	(Rd) 10K Ω 1/4W
R5123,5124	06S44593P65	(Rd) 1K Ω 1/4W
R5125,5126	06S44593P65	(Rd) 1K Ω 1/4W
R5129,5130	06S44593P65	(Rd) 1K Ω 1/4W
R5131,5132	06S44593P77	(Rd) 3.3K Ω 1/4W
R5133,5134	06S44593P41	(Rd) 100 Ω 1/4W
R5135,5136	06S44593P89	(Rd) 10K Ω 1/4W
R5138	06S44593P53	(Rd) 330 Ω 1/4W
R8001	06T60793F03	(Rm) 51K Ω 1/4W

K-05

Symbol No.	Stock No.	Description
R8002	06T60793F02	(Rm) 6.8KΩ 1/4W
R8003	06T60793F01	(Rm) 2.7KΩ 1/4W
R8004	06T60793F01	(Rm) 2.7KΩ 1/4W
R8005	06T60793F02	(Rm) 6.8KΩ 1/4W
R8006	06T60793F03	(Rm) 51KΩ 1/4W
R8007	06S44593P89	(Rd) 10KΩ 1/4W
R8008	06S44593P89	(Rd) 10KΩ 1/4W
R8009	06S44593P89	(Rd) 10KΩ 1/4W
R8010	06T61718P02	(Ts) 2.7KΩ 1/4W
R8011	06T61718F01	(Ts) 4.64KΩ 1/4W
R8012	06S44593P89	(Rd) 10KΩ 1/4W
R8013	06S44593P81	(Rd) 4.7KΩ 1/4W
R8014	06S44594P14	(Rd) 100KΩ 1/4W
R8015	06S44593P89	(Rd) 10KΩ 1/4W
R8016	06S44593P81	(Rd) 4.7KΩ 1/4W
R8017	06S44593P81	(Rd) 4.7KΩ 1/4W
R8018	06S44593P89	(Rd) 10KΩ 1/4W
R8019	06S44593P89	(Rd) 10KΩ 1/4W
R8020	06S44594P38	(Rd) 1MΩ 1/4W
R8021	06S44593P89	(Rd) 10KΩ 1/4W
R8022	06S44593P72	(Rd) 2KΩ 1/4W
R8023	06S44593P96	(Rd) 20KΩ 1/4W
R8024	06S44593P89	(Rd) 10KΩ 1/4W
R8025	06S44593P81	(Rd) 4.7KΩ 1/4W
R8026	06S44593P81	(Rd) 4.7KΩ 1/4W
R8028	06S44593P81	(Rd) 4.7KΩ 1/4W
R8029	06S44593P89	(Rd) 10KΩ 1/4W
R8030	06S44593P89	(Rd) 10KΩ 1/4W
R8031	06S44593P89	(Rd) 10KΩ 1/4W
R8032	06S44593P89	(Rd) 10KΩ 1/4W
R8033	06S44593P52	(Rd) 300Ω 1/4W
R8034	06S44593P52	(Rd) 300Ω 1/4W
R8040	06S44593P89	(Rd) 10KΩ 1/4W
R8041	06S44593P89	(Rd) 10KΩ 1/4W
R8042	06S44593P89	(Rd) 10KΩ 1/4W
R8043	06S44593P81	(Rd) 4.7KΩ 1/4W
R8044	06S44593P81	(Rd) 4.7KΩ 1/4W
R8045	06S44593P89	(Rd) 10KΩ 1/4W
R8046	06S44593P81	(Rd) 4.7KΩ 1/4W
R8047	06S44593P89	(Rd) 10KΩ 1/4W
R8048	06S44594P14	(Rd) 100KΩ 1/4W
R8049	06S44594P14	(Rd) 100KΩ 1/4W
R8050	06S44594P14	(Rd) 100KΩ 1/4W
R8051	06S44593P81	(Rd) 4.7KΩ 1/4W
R8052	06S44594P02	(Rd) 33KΩ 1/4W
R8053	06S44593P97	(Rd) 22KΩ 1/4W
R8054	06S44594P02	(Rd) 33KΩ 1/4W
R8055	06S44593P93	(Rd) 15KΩ 1/4W
R8056	06S44593P93	(Rd) 15KΩ 1/4W
R8057	06S44593P89	(Rd) 10KΩ 1/4W
R8058	06S44593P65	(Rd) 1KΩ 1/4W
R8059	06S44593P97	(Rd) 22KΩ 1/4W
R8060	06S44593P65	(Rd) 1KΩ 1/4W
R8061	06S44594P02	(Rd) 33KΩ 1/4W
R8062	06S44593P87	(Rd) 8.2KΩ 1/4W
R8063	06S44593P65	(Rd) 1KΩ 1/4W
R8064	06S44594P20	(Rd) 180KΩ 1/4W
R8065	06S44593P89	(Rd) 10KΩ 1/4W

Symbol No.	Stock No.	Description
R8066	06S44593P49	(Rd) 220Ω 1/4W
R8067	06S44593P81	(Rd) 4.7KΩ 1/4W
R8068	06S44593P81	(Rd) 4.7KΩ 1/4W
R8069	06S44593P89	(Rd) 10KΩ 1/4W
R8070	06S44593P89	(Rd) 10KΩ 1/4W
R8071	06S44593P89	(Rd) 10KΩ 1/4W
R8072	06S44593P81	(Rd) 4.7KΩ 1/4W
R8073	06S44593P89	(Rd) 10KΩ 1/4W
R8074	06S44593P81	(Rd) 4.7KΩ 1/4W
R8075	06S44593P81	(Rd) 4.7KΩ 1/4W
R8076	06S44594P38	(Rd) 1MΩ 1/4W
R8077	06S44593P81	(Rd) 4.7KΩ 1/4W
R8078	06S44593P81	(Rd) 4.7KΩ 1/4W
R8079	06S44593P81	(Rd) 4.7KΩ 1/4W
R8080	06S44593P89	(Rd) 10KΩ 1/4W
R8081	06S44593P96	(Rd) 20KΩ 1/4W
R8082	06S44593P89	(Rd) 10KΩ 1/4W
R8084	06S44593P81	(Rd) 4.7KΩ 1/4W
R8088	06S44593P89	(Rd) 10KΩ 1/4W
R8089	06S44593P65	(Rd) 1KΩ 1/4W
R8090	06S44593P89	(Rd) 10KΩ 1/4W
R8092	06S44594P14	(Rd) 100KΩ 1/4W
R8094	06S44594P14	(Rd) 100KΩ 1/4W
R8095	06S44594P14	(Rd) 100KΩ 1/4W
R8096	06S44594P04	(Rd) 39KΩ 1/4W
R8097	06S44593P97	(Rd) 22KΩ 1/4W
R8098	06S44593P96	(Rd) 20KΩ 1/4W
R8099	06S44593P89	(Rd) 10KΩ 1/4W
R8100	06S44593P81	(Rd) 4.7KΩ 1/4W
R8108	06S44594P14	(Rd) 100KΩ 1/4W
R8109	06S44593P65	(Rd) 1KΩ 1/4W
R8110	06S44594P14	(Rd) 100KΩ 1/4W
R8111	06S44594P06	(Rd) 47KΩ 1/4W
R8112	06S44593P89	(Rd) 10KΩ 1/4W
R8113	06S44594P14	(Rd) 100KΩ 1/4W
R8114	06S44593P89	(Rd) 10KΩ 1/4W
R8115	06S44593P65	(Rd) 1KΩ 1/4W
R8301	06S44593P65	(Rd) 1KΩ 1/4W
R8303	06S44593P65	(Rd) 1KΩ 1/4W
R8304	06S44593P65	(Rd) 1KΩ 1/4W
R8305	06S44593P77	(Rd) 3.3KΩ 1/4W
R8306	06S44593P87	(Rd) 8.2KΩ 1/4W
R8311	06S44593P89	(Rd) 10KΩ 1/4W
R8314	06S44593P89	(Rd) 10KΩ 1/4W
R8315	06S44594P14	(Rd) 100KΩ 1/4W
R8318	06S44594P38	(Rd) 1MΩ 1/4W
R8319	06S44594P38	(Rd) 1MΩ 1/4W
R8320	06S44594P14	(Rd) 100KΩ 1/4W
R8321	06S44593P89	(Rd) 10KΩ 1/4W
R8323	06S44593P89	(Rd) 10KΩ 1/4W
R8324	06S44593P89	(Rd) 10KΩ 1/4W
R8325	06S44594P38	(Rd) 1MΩ 1/4W

Lamp PCB Parts List

Symbol No.	Stock No.	Description
(Lamp)		
PL1001	65T56033F02	8V/200MA (METER)

K-05

Dolby PCB Parts List

Symbol No.	Stock No.	Description
(Variable Resistor)		
VR3301,3302	18T43733P10	1.0K-1/2W
VR3501,3502	18T43733P15	10K-1/2W
VR3801,3802	18T43733P12	2.2K-B
(Coil)		
L3001,3002	24T52159F01	36mH
L3501,3502	24T51914F01	Trap 4.7mH
L3503,3504	24T52159F01	36mH
(MPX Filter)		
LF3001,3002	91T44717P01	105B
LF3003,3004	91T44717P02	19B
(IC)		
IC451	51T52144F01	NJM072D
IC3001	51T52144F01	NJM072D
IC3003,3004	51T52160F01	HA12038-01
IC3301	51T52144F01	NJM072D
IC3503,3504	51T52160F01	HA12038-01
IC3801	51T52144F01	NJM072D
(Transistor, FET)		
Q3001,3002	48T51878F01	2SC2878 A, B
Q3003,3004	48S47729F02	2SK117 BL
Q3913	48S43525F05	2SC1815-Y, GR
Q3914	48T51118F01	2SA1015-Y
Q3915,3916	48T57305F01	2SD 1302-S, T
Q3917,3918	48T57305F01	2SD 1302-S, T
(Diode)		
D3001,3002	48T58583F01	SS176TPA7-AX
(Capacitor)		
C451,452	23S40657F13	(EI) 47uF 16V
C453,454	23T42477F38	(EI) 33uF 16V
C3003,3004	23T43197F09	(EI) 47uF 16V
C3005,3006	23T61177F01	(EI) 22uF 16V
C3011,3012	08T55260F45	(Ce) 470pF
C3015,3016	08S40656F03	(My) 1500pF
C3017,3018	08S40656F15	(My) 15000pF
C3019,3020	08S40656F15	(My) 15000pF
C3021,3022	23T42477F06	(EI) 10uF 16V
C3023,3024	08S40656F13	(My) 10000pF
C3025,3026	23T42477F09	(EI) 4.7uF 25V
C3027,3028	08S40656F16	(My) 18000pF
C3029,3030	08T57851F19	(Tf) 0.33uF
C3031,3032	08T57851F19	(Tf) 0.33uF
C3033,3034	23T42477F16	(EI) 1.0uF 50V
C3035,3036	23T42477F16	(EI) 1.0uF 50V
C3037,3038	08S40656F01	(My) 1000pF
C3039,3040	08S40656F07	(My) 3300pF
C3041,3042	08S40656F08	(My) 3900pF
C3043,3044	08S40656F10	(My) 5600pF
C3045,3046	08T55260F27	(Ce) 39pF
C3047,3048	23T61177F01	(EI) 22uF 16V
C3049,3050	23T42477F06	(EI) 10uF 16V
C3051,3052	08S40656F24	(My) 82000pF
C3053,3054	23T42477F09	(EI) 4.7uF 25V
C3055,3056	08T57851F15	(Tf) 0.15uF
C3057,2058	08T50579F21	(Tf) 0.47uF
C3059,3060	23T42477F02	(EI) 22uF 10V

Symbol No.	Stock No.	Description
C3061,3062	23T43197F10	(EI) 100uF 16V
C3063,3064	23T43197F10	(EI) 100uF 16V
C3301,3302	23T43197F09	(EI) 47uF 16V
C3303,3304	23T61177F01	(EI) 22uF 16V
C3507,3508	08T55260F45	(Ce) 470pF
C3509,3510	08T55260F45	(Ce) 470pF
C3513,3514	08S40656F03	(My) 1500pF
C3514,3515	08S40656F15	(My) 15000pF
C3517,3518	08S40656F15	(My) 15000pF
C3519,3520	23T42477F06	(EI) 10uF 16V
C3521,3522	08S40656F13	(My) 10000pF
C3523,3524	08S40656F16	(My) 18000pF
C3525,3526	23T42477F09	(EI) 4.7uF 25V
C3527,3528	08T57851F19	(Tf) 0.33uF
C3529,3530	08T57851F19	(Tf) 0.33uF
C3531,3532	23T42477F16	(EI) 1.0uF 50V
C3533,3534	23T42477F16	(EI) 1.0uF 50V
C3535,3536	08S40656F01	(My) 1000pF
C3537,3538	08S40656F07	(My) 3300pF
C3539,3540	08S40656F08	(My) 3900pF
C3541,3542	08S40656F10	(My) 5600pF
C3543,3544	08T55260F27	(Ce) 39pF
C3545,3546	23T42477F06	(EI) 10uF 16V
C3547,3548	08S40656F24	(My) 82000pF
C3549,3550	23T42477F09	(EI) 4.7uF 25V
C3551,3552	08T57851F15	(Tf) 0.15uF
C3553,3554	08T50579F21	(Tf) 0.47uF
C3555,3556	23T42477F02	(EI) 22uF 10V
C3557,3558	23T43197F10	(EI) 100uF 16V
C3559,3560	23T43197F10	(EI) 100uF 16V
C3801,3802	23T43197F09	(EI) 47uF 16V
C3905,3906	23T42477F16	(EI) 1.0uF 50V
C3907,3908	23T42477F15	(EI) 0.47uF 50V
(Resistor)		
R453,454	06S55066F19	(Rd) 160KΩ 1/6W
R455,456	06S55066F17	(Rd) 130KΩ 1/6W
R3001,3002	06S55066F30	(Rd) 470KΩ 1/6W
R3003,3004	06S55066F74	(Rd) 2.4KΩ 1/6W
R3005,3006	06S55066F89	(Rd) 10KΩ 1/6W
R3007,3008	06S55066F89	(Rd) 10KΩ 1/6W
R3009,3010	06S55066F83	(Rd) 5.6KΩ 1/6W
R3011,3012	06S55066F87	(Rd) 8.2KΩ 1/6W
R3015,3016	06S55066F77	(Rd) 3.3KΩ 1/6W
R3017,3018	06S55066F65	(Rd) 1KΩ 1/6W
R3019,3020	06S55066F41	(Rd) 100Ω 1/6W
R3021,3022	06S55066F82	(Rd) 5.1KΩ 1/6W
R3023,3024	06S55066F93	(Rd) 15KΩ 1/6W
R3025,3026	06S55066F06	(Rd) 47KΩ 1/6W
R3027,3028	06S55066F84	(Rd) 6.2KΩ 1/6W
R3029,3030	06S55066F12	(Rd) 82KΩ 1/6W
R3031,3032	06S55066F38	(Rd) 1MΩ 1/6W
R3033,3034	06S55066F81	(Rd) 4.7KΩ 1/6W
R3035,3036	06S55066F50	(Rd) 240Ω 1/6W
R3037,3038	06S55066F87	(Rd) 8.2KΩ 1/6W
R3039,3040	06S55066F49	(Rd) 220Ω 1/6W
R3041,3042	06S55066F89	(Rd) 10KΩ 1/6W
R3043,3044	06S55066F10	(Rd) 68KΩ 1/6W
R3045,3046	06S55066F30	(Rd) 470KΩ 1/6W

K-05

Symbol No.	Stock No.	Description
R3047,3048	06S55066F08	(Rd) 56KΩ 1/6W
R3049,3050	06S55066F84	(Rd) 6.2KΩ 1/6W
R3051,3052	06S55066F12	(Rd) 82KΩ 1/6W
R3053,3054	06S55066F89	(Rd) 10KΩ 1/6W
R3055,3056	06S55066F02	(Rd) 33KΩ 1/6W
R3057,3058	06S55066F14	(Rd) 100KΩ 1/6W
R3059,3060	06S55066F14	(Rd) 100KΩ 1/6W
R3303,3304	06S55066F97	(Rd) 22KΩ 1/6W
R3305,3306	06S55066F69	(Rd) 1.5KΩ 1/6W
R3503,3504	06S55066F89	(Rd) 10KΩ 1/6W
R3505,3506	06S55066F08	(Rd) 56KΩ 1/6W
R3507,3508	06S55066F87	(Rd) 8.2KΩ 1/6W
R3509,3510	06S55066F30	(Rd) 470KΩ 1/6W
R3511,3512	06S55066F77	(Rd) 3.3KΩ 1/6W
R3513,3514	06S55066F65	(Rd) 1KΩ 1/6W
R3515,3516	06S55066F41	(Rd) 100Ω 1/6W
R3517,3518	06S55066F82	(Rd) 5.1KΩ 1/6W
R3519,3520	06S55066F93	(Rd) 15KΩ 1/6W
R3521,3522	06S55066F06	(Rd) 47KΩ 1/6W
R3523,3524	06S55066F84	(Rd) 6.2KΩ 1/6W
R3525,3526	06S55066F12	(Rd) 82KΩ 1/6W
R3527,3528	06S55066F38	(Rd) 1MΩ 1/6W
R3529,3530	06S55066F81	(Rd) 4.7KΩ 1/6W
R3531,3532	06S55066F50	(Rd) 240Ω 1/6W
R3533,3534	06S55066F87	(Rd) 8.2KΩ 1/6W
R3535,3536	06S55066F49	(Rd) 220Ω 1/6W
R3537,3538	06S55066F89	(Rd) 10KΩ 1/6W
R3539,3540	06S55066F10	(Rd) 68KΩ 1/6W
R3541,3542	06S55066F08	(Rd) 56KΩ 1/6W
R3543,3544	06S55066F84	(Rd) 6.2KΩ 1/6W
R3545,3546	06S55066F12	(Rd) 82KΩ 1/6W
R3547,3548	06S55066F89	(Rd) 10KΩ 1/6W
R3549,3550	06S55066F02	(Rd) 33KΩ 1/6W
R3803,3804	06S55066F97	(Rd) 22KΩ 1/6W
R3805,3806	06S55066F65	(Rd) 1KΩ 1/6W
R3931,3932	06S55066F30	(Rd) 470KΩ 1/6W
R3933,3934	06S55066F30	(Rd) 470KΩ 1/6W
R3935	06S55066F77	(Rd) 3.3KΩ 1/6W
R3936	06S55066F89	(Rd) 10KΩ 1/6W
R3937	06S55066F89	(Rd) 10KΩ 1/6W
R3938	06S55066F89	(Rd) 10KΩ 1/6W
R3939	06S55066F89	(Rd) 10KΩ 1/6W
R3940	06S55066F77	(Rd) 3.3KΩ 1/6W
R3941,3942	06S55066F77	(Rd) 3.3KΩ 1/6W
R3943,3944	06S55066F77	(Rd) 3.3KΩ 1/6W
R3945,3946	06S55066F17	(Rd) 130KΩ 1/6W
R3949,3950	06S55066F39	(Rd) 82Ω 1/6W

REC EQ PCB Parts List

Symbol No.	Stock No.	Description
(Variable Resistor)		
VR5501,5502	18T45040F14	0.3W-15K
VR5503,5504	18T45040F14	0.3W-15K
VR5505,5506	18T45040F14	0.3W-15K
VR5509,5510	18T45040F11	0.3W-4.7K
VR5511,5512	18T45040F11	0.3W-4.7K
VR5513,5514	18T45040F11	0.3W-4.7K

Symbol No.	Stock No.	Description
VR5517,5518	18T45040F14	0.3W-15K
VR5519,5520	18T45040F14	0.3W-15K
VR5521,5522	18T45040F14	0.3W-15K
(IC)		
IC5501,5502	51T57775F01	TL 072
(FET)		
Q5501,5502	48S47729F02	2SK117 BL
Q5503,5504	48S47729F02	2SK117 BL
Q5505,5506	48S47729F02	2SK117 BL
Q5509,5510	48S47729F02	2SK117 BL
Q5511,5512	48S47729F02	2SK117 BL
Q5513,5514	48S47729F02	2SK117 BL
(Diode)		
D5501,5502	48T58583F01	SS176TPA7-AX
D5503,5504	48T58583F01	SS176TPA7-AX
D5505,5506	48T58583F01	SS176TPA7-AX
D5509,5510	48T58583F01	SS176TPA7-AX
D5511,5512	48T58583F01	SS176TPA7-AX
D5513,5514	48T58583F01	SS176TPA7-AX
(Capacitor)		
C5501	08T55260F61	(Ce) 10000pF
C5502	08T55260F61	(Ce) 10000pF
C5503	08T55260F61	(Ce) 10000pF
C5505,5506	08T52448F39	(Pp) 12000pF
C5507,5508	08T52448F37	(Pp) 10000pF
C5509,5510	08T52448F21	(Pp) 2200pF
C5513,5514	23T42477F37	(El) 150uF 10V
C5515,5516	08T55260F17	(Ce) 15pF
C5517,5518	08T52448F13	(Pp) 1000pF
C5519,5520	08T52448F13	(Pp) 1000pF
C5521,5522	08T52448F11	(Pp) 0.00082uF
C5525,5526	08T55260F17	(Ce) 15pF
C5527	23T43197F10	(El) 100uF 16V
C5528	23T43197F10	(El) 100uF 16V
C5529,5530	08T55260F41	(Ce) 220pF
(Resistor)		
R5501	06S55066F95	(Rd) 18KΩ 1/6W
R5502	06S55066F95	(Rd) 18KΩ 1/6W
R5503	06S55066F95	(Rd) 18KΩ 1/6W
R5505,5506	06S55066F16	(Rd) 120KΩ 1/6W
R5507,5508	06S55066F53	(Rd) 330Ω 1/6W
R5509,5510	06S55066F77	(Rd) 3.3KΩ 1/6W
R5511,5512	06S55066F77	(Rd) 3.3KΩ 1/6W
R5513,5514	06S55066F77	(Rd) 3.3KΩ 1/6W
R5517,5518	06S55066F65	(Rd) 1KΩ 1/6W
R5519,5520	06S55066F65	(Rd) 1KΩ 1/6W
R5521,5522	06S55066F65	(Rd) 1KΩ 1/6W
R5525,5526	06S55066F89	(Rd) 10KΩ 1/6W
R5527,5528	06S55066F86	(Rd) 7.5KΩ 1/6W
R5529,5530	06S55066F89	(Rd) 10KΩ 1/6W
R5533,5534	06S55066F65	(Rd) 1KΩ 1/6W
R5535,5536	06S55066F65	(Rd) 1KΩ 1/6W
R5537,5538	06S55066F73	(Rd) 2.2KΩ 1/6W
R5541,5542	06S55066F07	(Rd) 51KΩ 1/6W
R5543,5544	06S55066F02	(Rd) 33KΩ 1/6W
R5545,5546	06S55066F16	(Rd) 120KΩ 1/6W
R5547,5548	06S55066F53	(Rd) 330Ω 1/6W
R5549,5550	06S55066F97	(Rd) 22KΩ 1/6W

Symbol No.	Stock No.	Description
R5551,5552	06S55065F97	(Rd) 22KΩ 1/6W
R5553,5554	06S55065F97	(Rd) 22KΩ 1/6W
R5557,5558	06S55065F53	(Rd) 330Ω 1/6W
R5559,5560	06S55065F53	(Rd) 330Ω 1/6W
R5561,5562	06S55065F53	(Rd) 330Ω 1/6W

Control PCB Parts List

Symbol No.	Stock No.	Description
(IC)		
IC6001	51T51994F01	HD38805A03
IC6002	51T51782F01	MC14028BCP
IC6003	51T52158F01	TD62504
IC6004	51T52158F01	TD62504
IC6005	51T52154F01	NJM2901N
IC6006	51T51781F01	MC14049UB
IC6007	51T52158F01	TD62504

(Filter)		
CF6001	91T52156F01	400P

(Transistor)		
Q6001	48T51118F01	2SA1015-Y
Q6002	48T51118F01	2SA1015-Y
Q6003	48T51089F01	2SA937 Q,R
Q6004	48S43525F05	2SC1815-Y,GR
Q6005	48T56031F01	2SD1266-P,Q
Q6006	48T56031F01	2SD1266-P,Q
Q6007	48T56032F01	2SB977A
Q6008	48T56032F01	2SB977A
Q6009	48T41365F01	2SD893 P
Q6010	48T41365F01	2SD893 P
Q6011	48S43525F05	2SC1815-Y,GR
Q6012	48S43525F05	2SC1815-Y,GR
Q6013	48T56032F01	2SB977A
Q6014	48T56032F01	2SB977A
Q6015	48T41365F01	2SD893 P
Q6016	48T41365F01	2SD893 P
Q6017	48T56031F01	2SD1266-P,Q
Q6018	48T41365F01	2SD893 P
Q6019	48T41197U03	2SA777-R
Q6020	48T41197U03	2SA777-R
Q6021	48T41197U03	2SA777-R
Q6022	48S43525F05	2SC1815-Y,GR
Q6023	48T56031F01	2SD1266-P,Q

(Diode)		
D6001	48T58583F01	SS176TPA7-AX
D6002	48T58583F01	SS176TPA7-AX
D6003	48T58583F01	SS176TPA7-AX
D6004	48T58583F01	SS176TPA7-AX
D6005	48T58583F01	SS176TPA7-AX
D6008	48T58583F01	SS176TPA7-AX
D6009	48T58583F01	SS176TPA7-AX
D6010	48T58583F01	SS176TPA7-AX
D6011	48T58583F01	SS176TPA7-AX
D6012	48T58583F01	SS176TPA7-AX
D6013	48T58583F01	SS176TPA7-AX
D6014	48T58583F01	SS176TPA7-AX
D6015	48T58583F01	SS176TPA7-AX
D6016	48T58583F01	SS176TPA7-AX

(FD)

Symbol No.	Stock No.	Description
D6017	48T58583F01	SS176TPA7-AX
D6018	48T58583F01	SS176TPA7-AX
D6019	48T58583F01	SS176TPA7-AX
D6020	48T58583F01	SS176TPA7-AX
D6021	48T58583F01	SS176TPA7-AX
D6022	48T58583F01	SS176TPA7-AX
D6023	48T58583F01	SS176TPA7-AX
D6024	48T58583F01	SS176TPA7-AX
D6026	48T58583F01	SS176TPA7-AX
D6027	48T58583F01	SS176TPA7-AX
D6028	48T58583F01	SS176TPA7-AX
D6029	48T58583F01	SS176TPA7-AX
D6030	48T58583F01	SS176TPA7-AX
D6031	48T58583F01	SS176TPA7-AX
D6032	48T58583F01	SS176TPA7-AX
D6033	48T58583F01	SS176TPA7-AX
D6034	48T58583F01	SS176TPA7-AX
D6035	48T58583F01	SS176TPA7-AX
D6036	48T58583F01	SS176TPA7-AX
D6037	48T58583F01	SS176TPA7-AX
D6038	48T58583F01	SS176TPA7-AX
D6039	48T58583F01	SS176TPA7-AX
D6040	48T58583F01	SS176TPA7-AX
D6041	48T58583F01	SS176TPA7-AX
D6042	48T58583F01	SS176TPA7-AX
D6043	48T58583F01	SS176TPA7-AX
D6044	48T58583F01	SS176TPA7-AX
D6045	48T58583F01	SS176TPA7-AX
D6046	48T58583F01	SS176TPA7-AX
D6047	48T58583F01	SS176TPA7-AX
D6048	48T58583F01	SS176TPA7-AX
D6049	48T58583F01	SS176TPA7-AX
D6050	48S40477U01	1N4003

(Diode,Zener)		
ZD6001	48T40150U54	HZ11A-3
ZD6002	48T40150U86	HZ24-2
ZD6003	48T40150U69	HZ12C-3
ZD6004	48T40059U13	HZ7B-1L
ZD6004	48T40059U26	HZ9C-2L
ZD6005	48T40150U22	HZ5B-1
ZD6005	48T40150U28	HZ5A-1
ZD6006	48T40059U31	HZ11B-1L
ZD6006	48T40150U49	HZ9B-1
ZD6007	48T40150U14	HZ4B-2
ZD6008	48T40150U25	HZ5C-1
ZD6009	48T40150U56	HZ11B-2

(FD)

(FR)

(FD)

(FR)

(FD)

(FR)

(Capacitor)		
C6001	08T55260F61	(Ce) 10000pF
C6002	08T55260F61	(Ce) 10000pF
C6003	08T55260F61	(Ce) 10000pF
C6004	08T55260F61	(Ce) 10000pF
C6005	08T55260F61	(Ce) 10000pF
C6006	08T55260F61	(Ce) 10000pF
C6007	08T55260F61	(Ce) 10000pF
C6008	08T55260F45	(Ce) 470pF
C6009	08T55260F38	(Ce) 120pF
C6010	23S40657F10	(El) 10uF 16V
C6011	08T55260F58	(Ce) 4700pF

K-05

Symbol No.	Stock No.	Description
C6012	08T55260F58	(Ce) 4700pF
C6013	08T55260F58	(Ce) 4700pF
C6014	23S40657F17	(Ei) 10uF 25V
C6015	23S40657F17	(Ei) 10uF 25V
C6016	23S40657F10	(Ei) 10uF 16V
C6017	23S40657F10	(Ei) 10uF 16V
C6018	23S40657F10	(Ei) 10uF 16V
C6019	23S40657F10	(Ei) 10uF 16V
C6020	23S40657F10	(Ei) 10uF 16V
C6021	23S40657F10	(Ei) 10uF 16V
C6022	23S40657F10	(Ei) 10uF 16V
C6023	23S40657F10	(Ei) 10uF 16V
C6024	08T55260F61	(Ce) 10000pF
C6025	23S40657F10	(Ei) 10uF 16V
C6026	08T57851F19	(Tf) 0.33uF
C6027	08T57851F19	(Tf) 0.33uF
C6028	23S41059P19	(Ta) 4.7uF 25V
C6029	23S40657F10	(Ei) 10uF 16V
C6030	23S40475U27	
C6031	23S40657F17	(Ei) 10uF 25V
C6032	23S40657F07	(Ei) 47uF 10V
C6033	23S40657F10	(Ei) 10uF 16V
C6034	23S40657F09	(Ei) 220uF 10V
C6035	08T55260F45	(Ce) 470pF
C6036	23S40657F10	(Ei) 10uF 16V
C6037	23S40657F10	(Ei) 10uF 16V
C6038	23S41059P34	(Ta) 47uF 6.3V

(Resistor)

R6001	51T52333F01	(Alloy) 47KX8	
R6002	51T52333F02	(Alloy) 10KX4	(FR)
R6002	51T52333F07	(Alloy) 100KX4	(FD)
R6003	06S55065F65	(Rd) 1KΩ 1/6W	
R6004	06S55065F65	(Rd) 1KΩ 1/6W	
R6005	06S55065F65	(Rd) 1KΩ 1/6W	
R6006	06S55065F65	(Rd) 1KΩ 1/6W	
R6007	06S55065F65	(Rd) 1KΩ 1/6W	
R6008	06S55065F65	(Rd) 1KΩ 1/6W	
R6009	06S55065F65	(Rd) 1KΩ 1/6W	
R6010	06S55066F38	(Rd) 1MΩ 1/6W	
R6011	06S55065F49	(Rd) 220Ω 1/6W	
R6012	06S55065F49	(Rd) 220Ω 1/6W	
R6015	06S55065F51	(Rd) 270Ω 1/6W	
R6017	06S55065F49	(Rd) 220Ω 1/6W	
R6018	06D44744G19	(Rd) 82Ω 1/2W	
R6024	06S55065F89	(Rd) 10KΩ 1/6W	
R6025	06S55065F89	(Rd) 10KΩ 1/6W	
R6026	06S55065F65	(Rd) 1KΩ 1/6W	
R6027	06S55066F06	(Rd) 47KΩ 1/6W	
R6028	06S55065F89	(Rd) 10KΩ 1/6W	
R6029	06S55065F89	(Rd) 10KΩ 1/6W	
R6030	06S55066F06	(Rd) 47KΩ 1/6W	
R6031	06S55066F06	(Rd) 47KΩ 1/6W	
R6032	06S55066F06	(Rd) 47KΩ 1/6W	
R6033	06S55066F06	(Rd) 47KΩ 1/6W	
R6034	06S55066F06	(Rd) 47KΩ 1/6W	
R6035	06S55066F06	(Rd) 47KΩ 1/6W	
R6036	06S55065F89	(Rd) 10KΩ 1/6W	
R6037	06S55066F06	(Rd) 47KΩ 1/6W	

Symbol No.	Stock No.	Description
R6038	06S55065F89	(Rd) 10KΩ 1/6W
R6039	06S55066F06	(Rd) 47KΩ 1/6W
R6040	06S55066F14	(Rd) 100KΩ 1/6W
R6041	06S55066F14	(Rd) 100KΩ 1/6W
R6042	06S55065F89	(Rd) 10KΩ 1/6W
R6043	06S55066F06	(Rd) 47KΩ 1/6W
R6044	06S55065F89	(Rd) 10KΩ 1/6W
R6045	06S55065F89	(Rd) 10KΩ 1/6W
R6046	06S55066F06	(Rd) 47KΩ 1/6W
R6047	06S55065F65	(Rd) 1KΩ 1/6W
R6048	06S55065F65	(Rd) 1KΩ 1/6W
R6049	06S55065F65	(Rd) 1KΩ 1/6W
R6050	06S55065F73	(Rd) 2.2KΩ 1/6W
R6051	06S55065F89	(Rd) 10KΩ 1/6W
R6052	06S55065F89	(Rd) 10KΩ 1/6W
R6053	06S55066F06	(Rd) 47KΩ 1/6W
R6054	06D44744G32	(Rd) 1KΩ 1/2W
R6055	06S55065F89	(Rd) 10KΩ 1/6W
R6056	06S55065F89	(Rd) 10KΩ 1/6W
R6057	06S55065F89	(Rd) 10KΩ 1/6W
R6058	06S55065F89	(Rd) 10KΩ 1/6W
R6059	06S55065F89	(Rd) 10KΩ 1/6W
R6060	06S55065F73	(Rd) 2.2KΩ 1/6W
R6061	06S55065F89	(Rd) 10KΩ 1/6W
R6062	06S55065F73	(Rd) 2.2KΩ 1/6W
R6063	06S55065F73	(Rd) 2.2KΩ 1/6W
R6064	06S55065F73	(Rd) 2.2KΩ 1/6W
R6065	06S55065F73	(Rd) 2.2KΩ 1/6W
R6066	06S55065F89	(Rd) 10KΩ 1/6W
R6067	06D44744G32	(Rd) 1KΩ 1/2W
R6068	06S55065F89	(Rd) 10KΩ 1/6W
R6069	06S55065F73	(Rd) 2.2KΩ 1/6W
R6070	06S55065F89	(Rd) 10KΩ 1/6W
R6071	06S55065F73	(Rd) 2.2KΩ 1/6W
R6072	06S55065F73	(Rd) 2.2KΩ 1/6W
R6073	06S55065F89	(Rd) 10KΩ 1/6W
R6074	06S55065F73	(Rd) 2.2KΩ 1/6W
R6075	06S55065F89	(Rd) 10KΩ 1/6W
R6076	06S55065F73	(Rd) 2.2KΩ 1/6W
R6077	06S55065F89	(Rd) 10KΩ 1/6W
R6078	06S55065F85	(Rd) 6.8KΩ 1/6W
R6079	06S55066F02	(Rd) 33KΩ 1/6W
R6080	06S55066F14	(Rd) 100KΩ 1/6W
R6081	06S55065F89	(Rd) 10KΩ 1/6W
R6082	06S55066F14	(Rd) 100KΩ 1/6W
R6083	06S55065F73	(Rd) 2.2KΩ 1/6W
R6084	06S55066F22	(Rd) 220KΩ 1/6W
R6085	06S55065F89	(Rd) 10KΩ 1/6W
R6086	06S55065F89	(Rd) 10KΩ 1/6W
R6087	06S55065F65	(Rd) 1KΩ 1/6W
R6088	06S55065F82	(Rd) 5.1KΩ 1/6W
R6089	06S55066F38	(Rd) 1MΩ 1/6W
R6090	06S55066F14	(Rd) 100KΩ 1/6W
R6091	06S55065F97	(Rd) 22KΩ 1/6W
R6092	06S55065F89	(Rd) 10KΩ 1/6W
R6093	06S55065F89	(Rd) 10KΩ 1/6W
R6094	06S55065F89	(Rd) 10KΩ 1/6W
R6095	06S55065F89	(Rd) 10KΩ 1/6W

Symbol No.	Stock No.	Description
R6096	06S55065F89	(Rd) 10KΩ 1/6W
R6097	06S55065F89	(Rd) 10KΩ 1/6W
R6098	06S55065F89	(Rd) 10KΩ 1/6W
R6099	06S55065F89	(Rd) 10KΩ 1/6W
R6100	06S55065F89	(Rd) 10KΩ 1/6W
R6101	06S55065F89	(Rd) 10KΩ 1/6W
R6102	06S55065F89	(Rd) 10KΩ 1/6W
R6103	06S55065F89	(Rd) 10KΩ 1/6W
R6104	06S55065F73	(Rd) 2.2KΩ 1/6W

LED & SW PCB Parts List

Symbol No.	Stock No.	Description
(Switch)		
SW8501	40T56504F01	KHG 10905 [CTS]
SW8502	40T56504F01	KHG 10905 [STD/CALL]
SW8503	40T56504F01	KHG 10905 [WRITE]
(LED)		
ED8501	48T52609F01	ORANGE TLO 163 [MPX]
ED8502	48T52609F01	ORANGE TLO 163 [SOURCE]
ED8503	48T52609F01	ORANGE TLO 163 [TAPE]
ED8504	48T52606F01	GREEN TLUG 163 [A/P]
ED8505	48T52606F01	GREEN TLUG 163 [A/R]
ED8506	48T52609F01	ORANGE TLO 163 [NR C]
ED8507	48T52609F01	ORANGE TLO 163 [NR B]
ED8508	48T52609F01	ORANGE TLO 163 [C]
ED8509	48T52609F01	ORANGE TLO 163 [C]
ED8510	48T52609F01	ORANGE TLO 163 [M]
ED8511	48T52609F01	ORANGE TLO 163 [M]
ED8514	48T52609F01	ORANGE TLO 163 [N]
ED8515	48T52609F01	ORANGE TLO 163 [N]
ED8516	48T52609F01	ORANGE TLO 163 [STD]
ED8517	48T52607F01	RED TLS 163 [ERR]
ED8518	48T52609F01	ORANGE TLO 163 [BIAS]
ED8519	48T52606F01	GREEN TLUG 163 [OK]
ED8520	48T52609F01	ORANGE TLO 163 [DATA]
ED8521	48T52607F01	RED TLS 163 [BATT.]
ED8522	48T52609F01	ORANGE TLO 163 [LEV]
ED8523	48T52609F01	ORANGE TLO 163 [EQ]
(Resistor)		
R8501	06S44593P48	(Rd) 200Ω 1/4W
R8502	06S44593P48	(Rd) 200Ω 1/4W
R8503	06S44593P48	(Rd) 200Ω 1/4W
R8504	06S44593P48	(Rd) 200Ω 1/4W
R8505	06S44593P48	(Rd) 200Ω 1/4W
R8506	06S44593P48	(Rd) 200Ω 1/4W
R8507	06S44593P48	(Rd) 200Ω 1/4W
R8508	06S44593P40	(Rd) 91Ω 1/4W
R8509	06S44593P40	(Rd) 91Ω 1/4W
R8511	06S44593P40	(Rd) 91Ω 1/4W
R8512	06S44593P48	(Rd) 200Ω 1/4W
R8513	06S44593P48	(Rd) 200Ω 1/4W
R8514	06S44593P48	(Rd) 200Ω 1/4W
R8515	06S44593P48	(Rd) 200Ω 1/4W
R8516	06S44593P48	(Rd) 200Ω 1/4W
R8517	06S44593P48	(Rd) 200Ω 1/4W
R8518	06S44593P48	(Rd) 200Ω 1/4W
R8519	06S44593P48	(Rd) 200Ω 1/4W

VR & SW PCB Parts List

Symbol No.	Stock No.	Description
(Switch)		
S4051	40T52408F01	SUT110 [PEAK/VU]
S6601	40T52408F01	SUT110 [A/PLAY]
S6602	40T52408F01	SUT110 [A/REW]
S6603	40T52408F01	SUT110 [MPX]
S6604	40T52408F01	SUT110 [SOURCE]
(Variable Resistor)		
VR2801,2802	18T60112F02	Slide 3013G 50K-B [REC LEVEL]
VR2803	18T58774F02	Slide 6023G 50K-BX2 [MASTER]
(Capacitor)		
C2807	08T55260F61	(Ce) 10000pF
C2808	08T55260F61	(Ce) 10000pF
(Resistor)		
R2801,2802	06S40150T99	(Rd) 27KΩ 1/4W
R2811	06S55065F77	(Rd) 3.3KΩ 1/6W
R2812	06S55065F89	(Rd) 10KΩ 1/6W

Pinch Control PCB Parts List

Symbol No.	Stock No.	Description
(Variable Resistor)		
VR6501	18T52411F02	K161 20KB [PITCH CONT.]
(IC)		
IC6501	51S43471U02	UPC4558C
(Transistor,FET)		
Q6301	48T51878F01	2SC2878 A, B
Q6501	48T52122F01	2SK301R
Q6502	48T52122F01	2SK301R
(Diode)		
D6301	48T51582F01	MA-150 -AX
D6302	48T51582F01	MA-150 -AX
D6501	48T51582F01	MA-150 -AX
D6502	48T51582F01	MA-150 -AX
(Capacitor)		
C6301	23S40657F51	(EI) 330uF 10V
C6501	23S40657F13	(EI) 47uF 16V
C6503	23S40657F13	(EI) 47uF 16V
(Resistor)		
R6301	06S44594P14	(Rd) 100KΩ 1/4W
R6302	06S44593P89	(Rd) 10KΩ 1/4W
R6303	06S44593P89	(Rd) 10KΩ 1/4W
R6304	06S44593P73	(Rd) 2.2KΩ 1/4W
R6501	06S44593P89	(Rd) 10KΩ 1/4W
R6502	06S44593P73	(Rd) 2.2KΩ 1/4W
R6503	06S44593P89	(Rd) 10KΩ 1/4W
R6504	06S44594P14	(Rd) 100KΩ 1/4W
R6505	06S44594P12	(Rd) 82KΩ 1/4W

Line Sensor PCB Parts List

Symbol No.	Stock No.	Description
(Resistor)		
R1901	06S44594P38	(Rd) 1MΩ 1/4W

Auto Erase PCB Parts List

Symbol No.	Stock No.	Description
(Relay)		
RY9001	80T52119F01	BR221D012
(Variable Resistor)		
VR9001	18T43733P15	10K-1/2W
(IC)		
IC9001	51S43471U02	UPC4558C
IC9002	51T51173F01	UPC4556C
(Transistor, FET)		
Q9001	48T58777F02	2SJ44 - M
Q9002	48S43525F03	2SC1815-GR
Q9003	48S43525F03	2SC1815-GR
Q9004	48S43525F03	2SC1815-GR
Q9005	48S43525F03	2SC1815-GR
(Diode)		
D9001	48T51582F01	MA-150 -AX
D9002	48T51582F01	MA-150 -AX
D9003	48T51582F01	MA-150 -AX
D9004	48T51582F01	MA-150 -AX
D9005	48T51582F01	MA-150 -AX
D9006	48T51582F01	MA-150 -AX
D9007	48T51582F01	MA-150 -AX
D9008	48T55186F01	GP10D -AX
(Diode, Zener)		
ZD9001	48T52739F19	HZ 4B-1 -AX
(Capacitor)		
C9001	08T52448F31	(Pp) 5600pF
C9002	08T52448F31	(Pp) 5600pF
C9003	08T44594P13	(Ce) 10pF
C9004	23T58711F31	(El) 2.2uF 50V
C9005	23T58711F31	(El) 2.2uF 50V
C9006	23T42477F06	(El) 10uF 16V
C9007	23T58711F11	(El) 10uF 16V
C9008	23T40657F52	(El) 220uF 16V
C9009	23S40657F10	(El) 10uF 16V
C9010	23S40657F11	(El) 22uF 16V
C9011	23S40657F10	(El) 10uF 16V
C9012	23S40657F10	(El) 10uF 16V
C9013	23S40657F10	(El) 10uF 16V
C9014	23S40657F10	(El) 10uF 16V
C9015	23S40657F08	(El) 100uF 10V
C9016	23S40657F06	(El) 33uF 10V
(Resistor)		
R9001	06S44594P02	(Rd) 33KΩ 1/4W
R9002	06S44593P99	(Rd) 27KΩ 1/4W
R9003	06S44594P05	(Rd) 43KΩ 1/4W
R9004	06S44594P14	(Rd) 100KΩ 1/4W
R9005	06S44593P97	(Rd) 22KΩ 1/4W
R9006	06S44593P81	(Rd) 4.7KΩ 1/4W
R9007	06S44593P89	(Rd) 10KΩ 1/4W
R9008	06S44594P30	(Rd) 470KΩ 1/4W
R9009	06S44594P08	(Rd) 56KΩ 1/4W
R9010	06S44593P67	(Rd) 1.2KΩ 1/4W
R9011	06S44594P20	(Rd) 180KΩ 1/4W
R9012	06S44593P97	(Rd) 22KΩ 1/4W
R9013	06S44593P89	(Rd) 10KΩ 1/4W
R9014	06S44593P81	(Rd) 4.7KΩ 1/4W

Symbol No.	Stock No.	Description
R9015	06S44593P65	(Rd) 1KΩ 1/4W
R9016	06S44594P26	(Rd) 330KΩ 1/4W
R9017,9018	06S44593P57	(Rd) 470Ω 1/4W
R9019	06S44593P81	(Rd) 4.7KΩ 1/4W
R9020	06S44594P11	(Rd) 75KΩ 1/4W
R9021	06S44594P16	(Rd) 120KΩ 1/4W
R9022	06S44593P87	(Rd) 8.2KΩ 1/4W
R9023	06S44594P14	(Rd) 100KΩ 1/4W
R9024	06S44593P89	(Rd) 10KΩ 1/4W
R9025	06S44593P81	(Rd) 4.7KΩ 1/4W
R9026	06S44593P89	(Rd) 10KΩ 1/4W
R9027	06S44593P75	(Rd) 2.7KΩ 1/4W
R9028	06S44593P41	(Rd) 100Ω 1/4W

Memory Key PCB Parts List

Symbol No.	Stock No.	Description
(Switch)		
S6908	40T44505F01	KHG [T/T]
S6909	40T44505F01	KHG [EXEC]
S6910	40T44505F01	KHG [CALL]
S6911	40T44505F01	KHG [WRITE]
S6912	40T44505F01	KHG [CLEAR]
(LED)		
ED6904	48T52609F01	ORANGE TLO 163 [EXEC]

Pulse OSC PCB Parts List

Symbol No.	Stock No.	Description
(IC)		
IC6351	51T51781F01	MC14049UB
(Diode)		
D6351	48T43189F01	1S1555
D6352	48T43189F01	1S1555
D6353	48T43189F01	1S1555
(Capacitor)		
C6351	23T42477F16	(El) 1.0uF 50V
C6352	23S40657F10	(El) 10uF 16V
C6353	08S40656F21	(My) 47000pF
C6354	23S40657F10	(El) 10uF 26V
(Resistor)		
R6351	06S44594P14	(Rd) 100KΩ 1/4W
R6352	06S44594P20	(Rd) 180KΩ 1/4W
R6353	06S44594P38	(Rd) 1MΩ 1/4W
R6354	06S44594P14	(Rd) 100KΩ 1/4W
R6355	06S44594P14	(Rd) 100KΩ 1/4W

Key Board SW PCB Parts List

Symbol No.	Stock No.	Description
(Switch, Tact)		
S6901	40T58028F02	(GRAY)-4 [STOP]
S6902	40T58028F02	(GRAY)-4 [FF]
S6903	40T58028F02	(GRAY)-4 [REW]
S6904	40T58028F02	(GRAY)-4 [PLAY]
S6905	40T58028F02	(GRAY)-4 [PAUSE]
S6906	40T58028F02	(GRAY)-4 [REC]
S6907	40T58028F02	(GRAY)-4 [REC MUTE]

Symbol No.	Stock No.	Description
(LED)		
ED6901	48T51833F03	GRN BG 4524K [PAUSE]
ED6902	48T51833F03	GRN BG 4524K [PLAY]
ED6903	48T51833F02	RED PR 4524K [REC]

NR SW PCB Parts List

Symbol No.	Stock No.	Description
(Relay)		
RY7001	80T52119F01	BR221D012
(Switch,Slide)		
S7001	40T58737F01	SSR
(Transistor)		
Q7001	48S43525F03	2SC1815-GR
(Diode)		
D7001	48T55186F01	GP10D -AX
(Capacitor)		
C7001	08S44505P61	(Ce) 10000pF
(Resistor)		
R7001	06S44593P91	(Rd) 12K Ω 1/4W
R7002	06S44593P81	(Rd) 4.7K Ω 1/4W
R7003,7004	06S44593P47	(Rd) 180 Ω 1/4W
R7005,7006	06S44593P47	(Rd) 180 Ω 1/4W

K-05

IC Handling Guide

MC14011BCP: (Stock No. 51T40242T01)

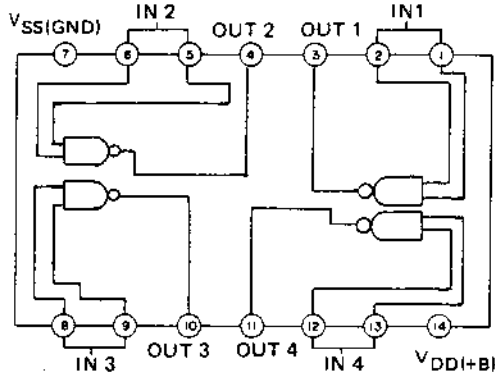
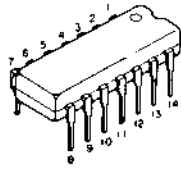

MC14081: (Stock No. 51T52157F01)

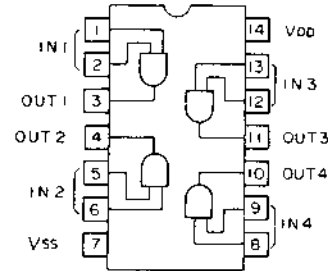
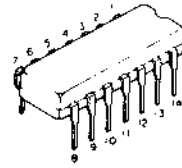

HD44801A48: (Stock No. 51T51993F01)

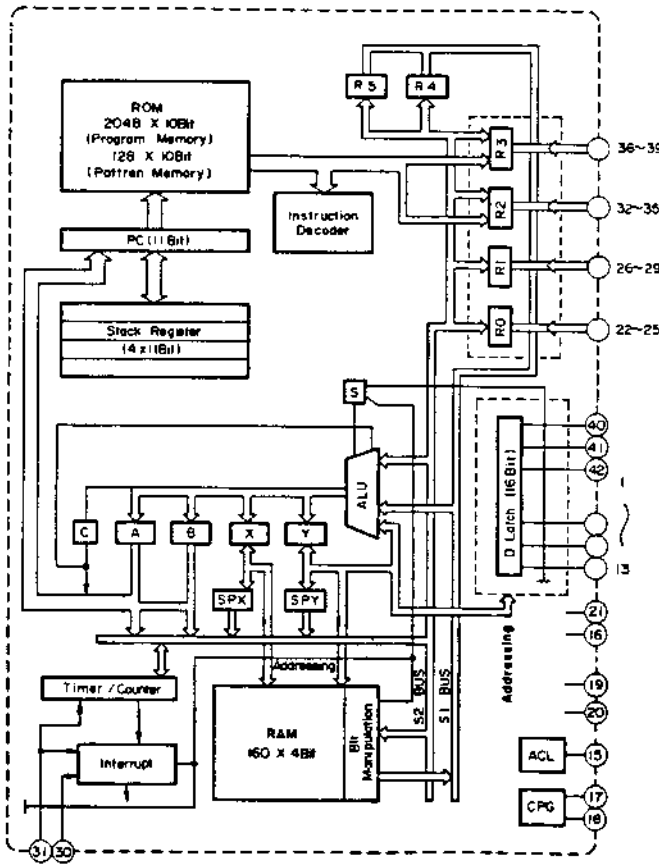
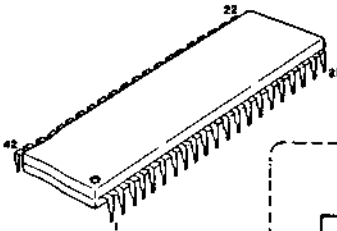

Pin No.	Code	Description
1	CPSR	CODING PULSE R
2	LRS L	L-R SELECT
3	ADRT	A/D RETURN
4	ADST	A/D START
5	ADRS	A/D RESET
6	TEST PWFL	TEST OUT POWER FAIL IN
7	ADSL	A/D SELECT
8	STD	LED
9	ERR	
10	BIAS	
11	OK	
12	MEM	TAPSELECT IN
13	BAT	
14		
15	RESET	RESET IN
16	GND	GROUND
17	OSC1	HOLT IN
18	OSC2	
19	HLT	
20	TEST	
21	Vcc	Vcc
22	NOR	REC EQ DATA LINE
23	CrO ₂	
24	FeCr	
25	METAL	
26	DT0 ATST	BLES START SW
27	DT1 STD	STD MEMORY SW
28	DT2 MEMW	STD MEMORY
29	DT3 PLM	REC PB SIGNAL DETECT
30	PULS	TAPE RUN PULSE IN
31	ATRL	AUTO TEST RELEASE
32	STOP	STOP OUT
33	REW	REW OUT
34	RPPS	REC PLAY PAUSE OUT
35	NINH	NOISE INHI OUT
36	LT50	REC EQ IC SELECT
37	LT51	
38	OSC0	OSC SELECT
39	OSC1	
40	DT4 BATT	REC EQ DATA LINE BATTERY CHECK
41	ADIN	A/D IN
41	BATX	BATTERY CHECK
42	CPS L	CODING PULSE L

TD62504: (Stock No. 51T52158F01)

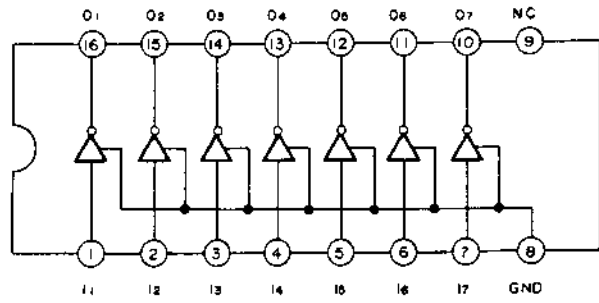

NJM2901N: (Stock No. 51T52154F01)

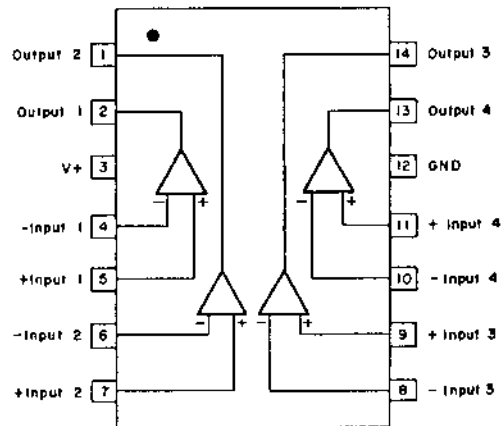
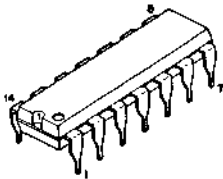

MC14049UB: (Stock No. 51T51781F01)

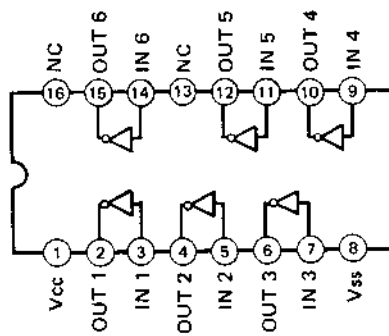
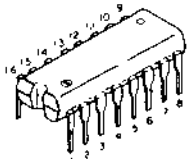

MC14066BCP: (Stock No. 51T40941U01)

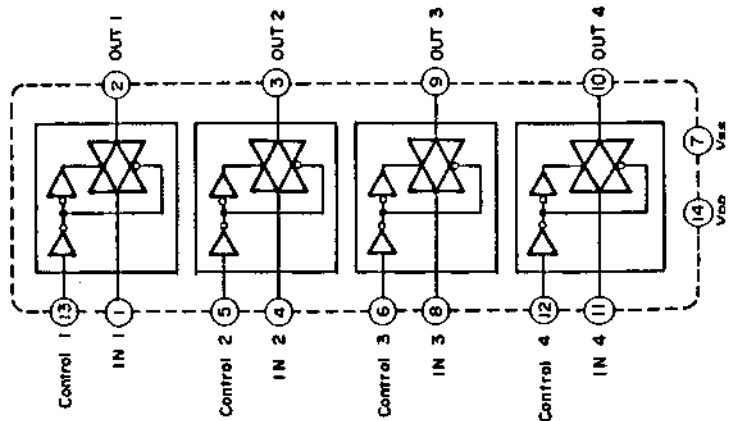
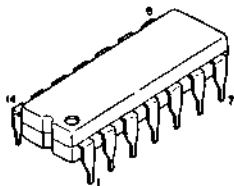

HD38805A03: (Stock No. 51T51994F01)

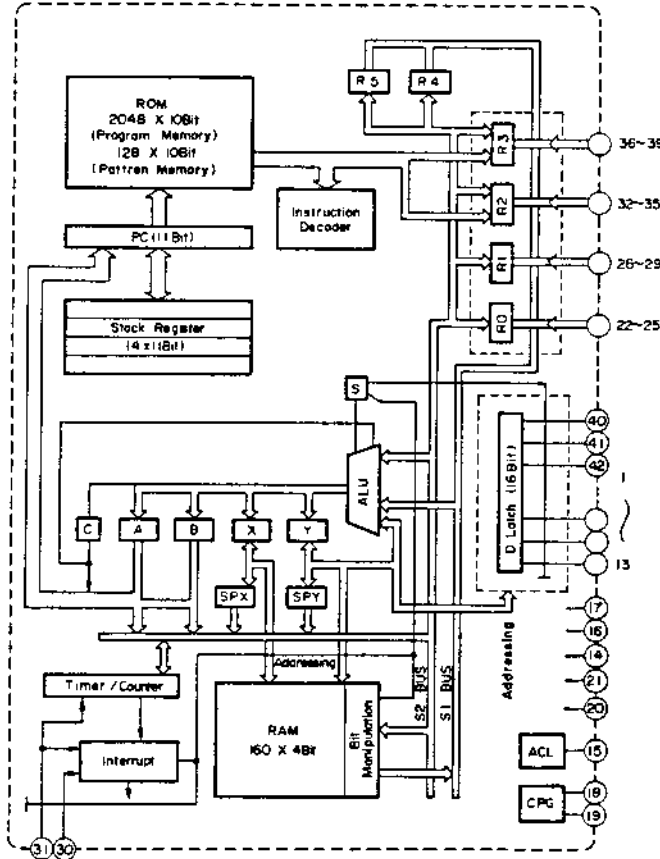
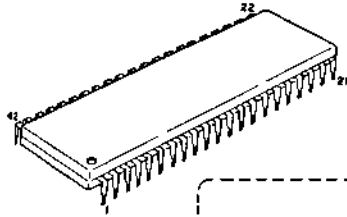

Pin No.	Code	Description
1	AMR	ASSIST MOTOR REVERSE
2	RMF	REEL MOTOR FORWARD
3	RMR	REEL MOTOR REVERSE
4	RMV	REEL MOTOR VOLTAGE
5	EBRK	ELECTROMAGNETIC BRAKE
6	PAMO	PLAY AMP MUTE OUT
7	RAMO	RECORD AMP MUTE OUT
8	RAMLO	RECORD AMP MUTE LED OUT
9	ATSO	AUTO TEST STOP OUT
10	EXCLO	EXECUTION LED OUT
11	WCTRO	WATCH COUNTER OUT
12	RECO	REC OUT
13	PALS	PULSE IN
14	VDISP	GND
15	RESET	
16	V9B	GND
17	VDD	
18	OSC1	
19	OSC2	
20	TEST	
21	V8	
22	STOP I	
23	FF I	
24	RWD I	
25	PLY I	
26	PAUSET	
27	REC I	REC IN
28	RECMI	REC MUTE IN
29	ATMD I	AUTO TEST MODE IN (REC EQ TEST IN)
30	POWER	POWER ON OFF IN
31	EXCPL	EXECUTION PULSE IN
32	KEY R0	
33	KEY R1	
34	KEY R2	
35	KEY R3	
36	PAUSE O	PAUSE OUT
37	PLAY O	PLAY OUT
38	FF O	FF OUT
39	RWD O	REW OUT
40	MX0	MATRIX STROBE LINE 0
41	MX1	MATRIX STROBE LINE 1
42	AMF	ASSIST MOTOR FORWARD

MC14028BCP: (Stock No. 51T51782F01)

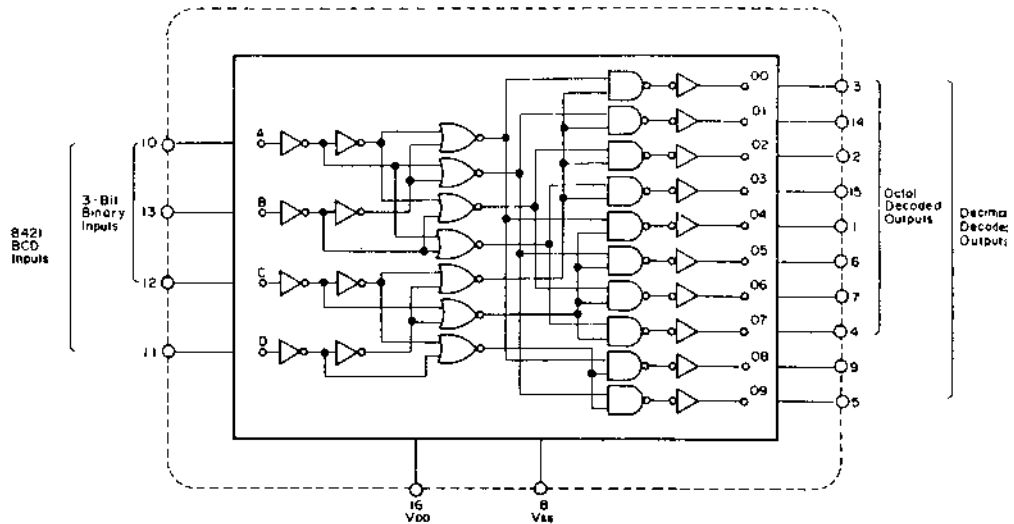
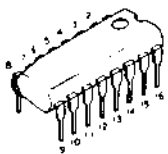

TA7332P: (Stock No. 51T47740F01)

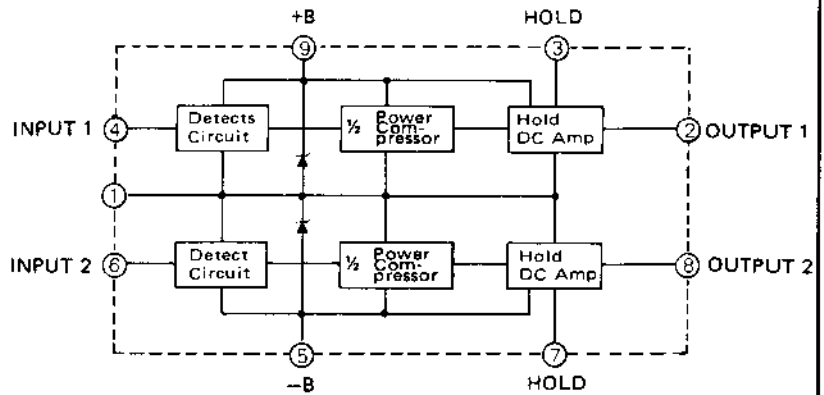
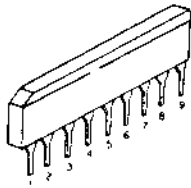

HA12020: (Stock No. 51T52145F01)

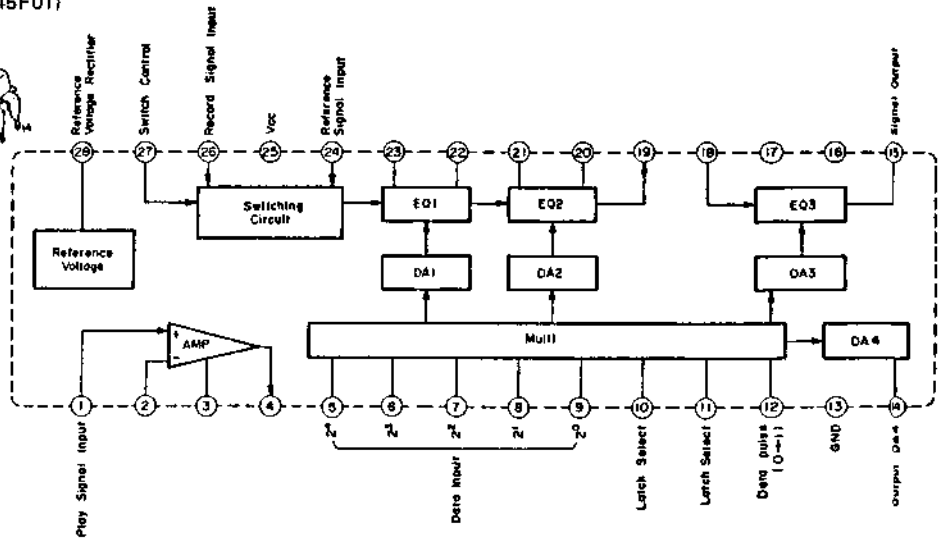
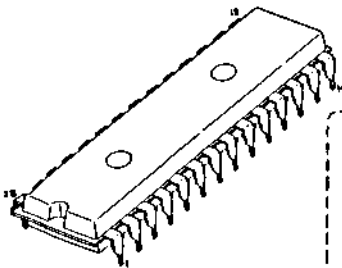

TL072: (Stock No. 51T57775F01)

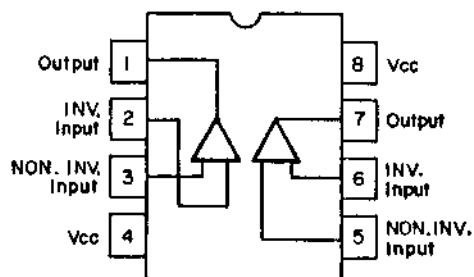
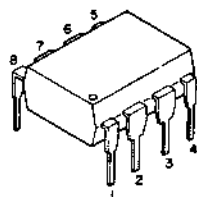

K-05

μPC4558C: (Stock No. 51S43471U02)
 μPC4556C (Stock No. 51T51173F01)
 NJM072D (Stock No. 51T52144F01)

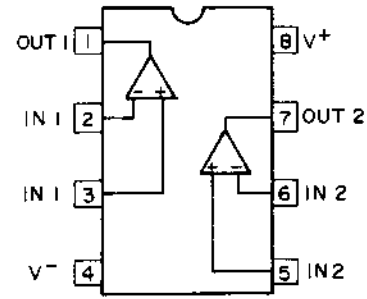
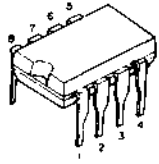

HA12038-01: (Stock No. 51T52160F01)

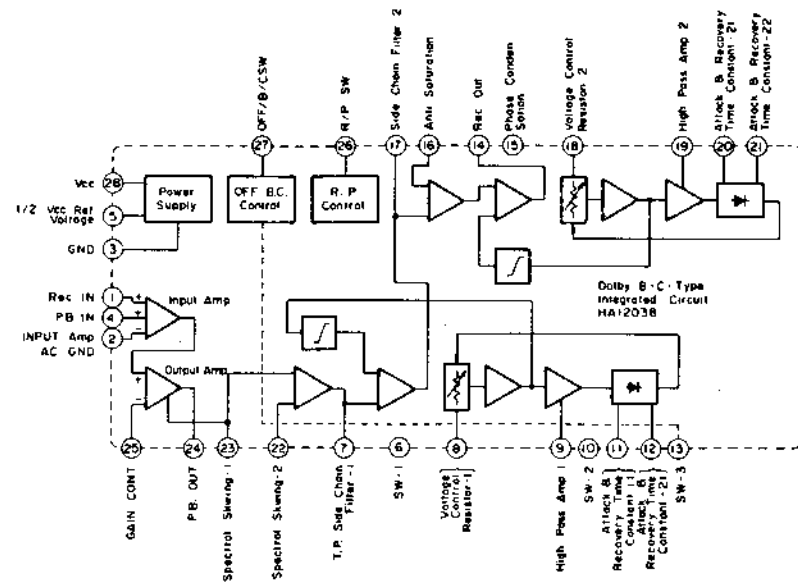
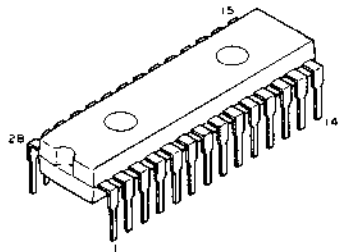

Schematic Diagram(1)

LUX K-05 SCHEMATIC DIAGRAM

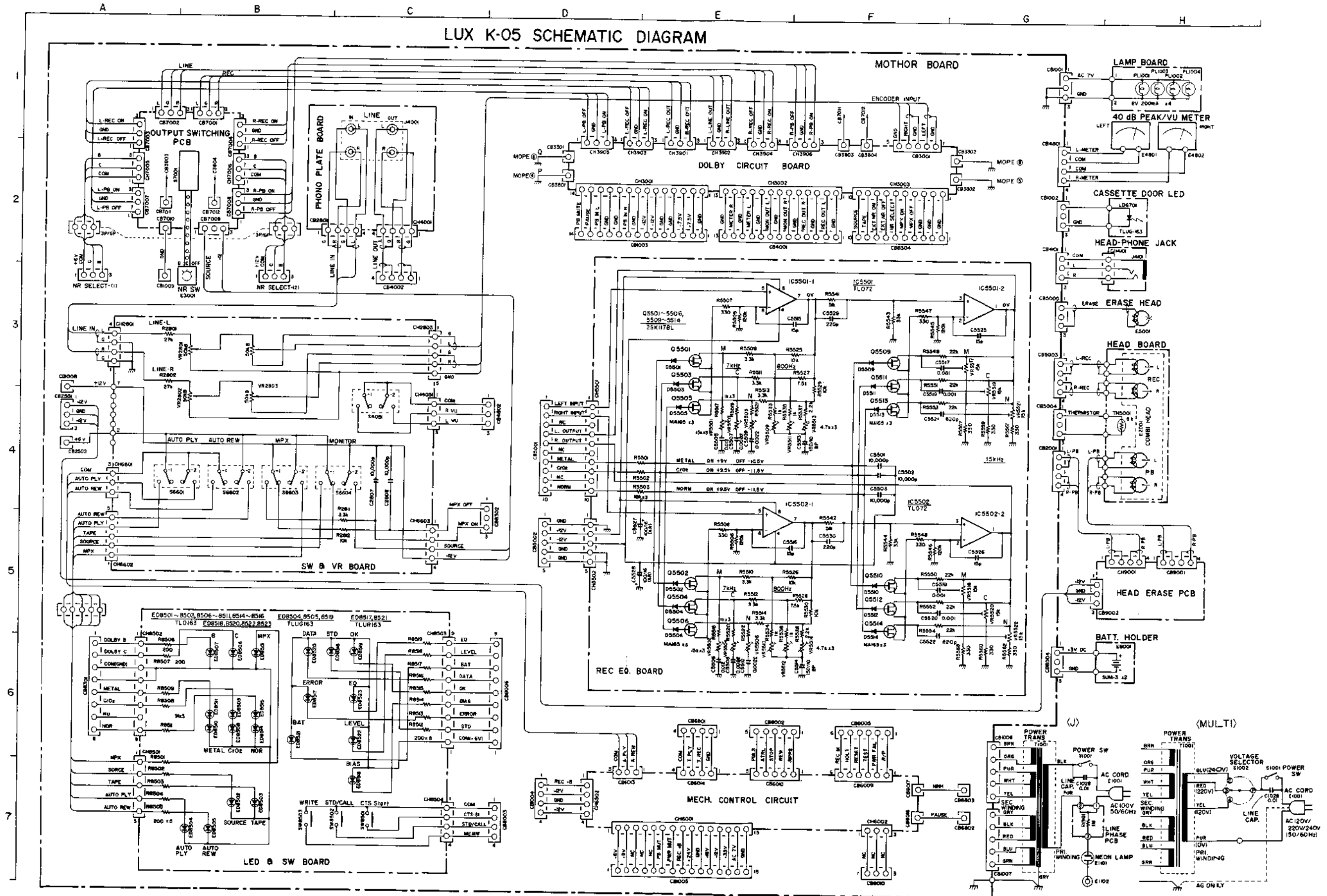

Schematic Diagram(2)

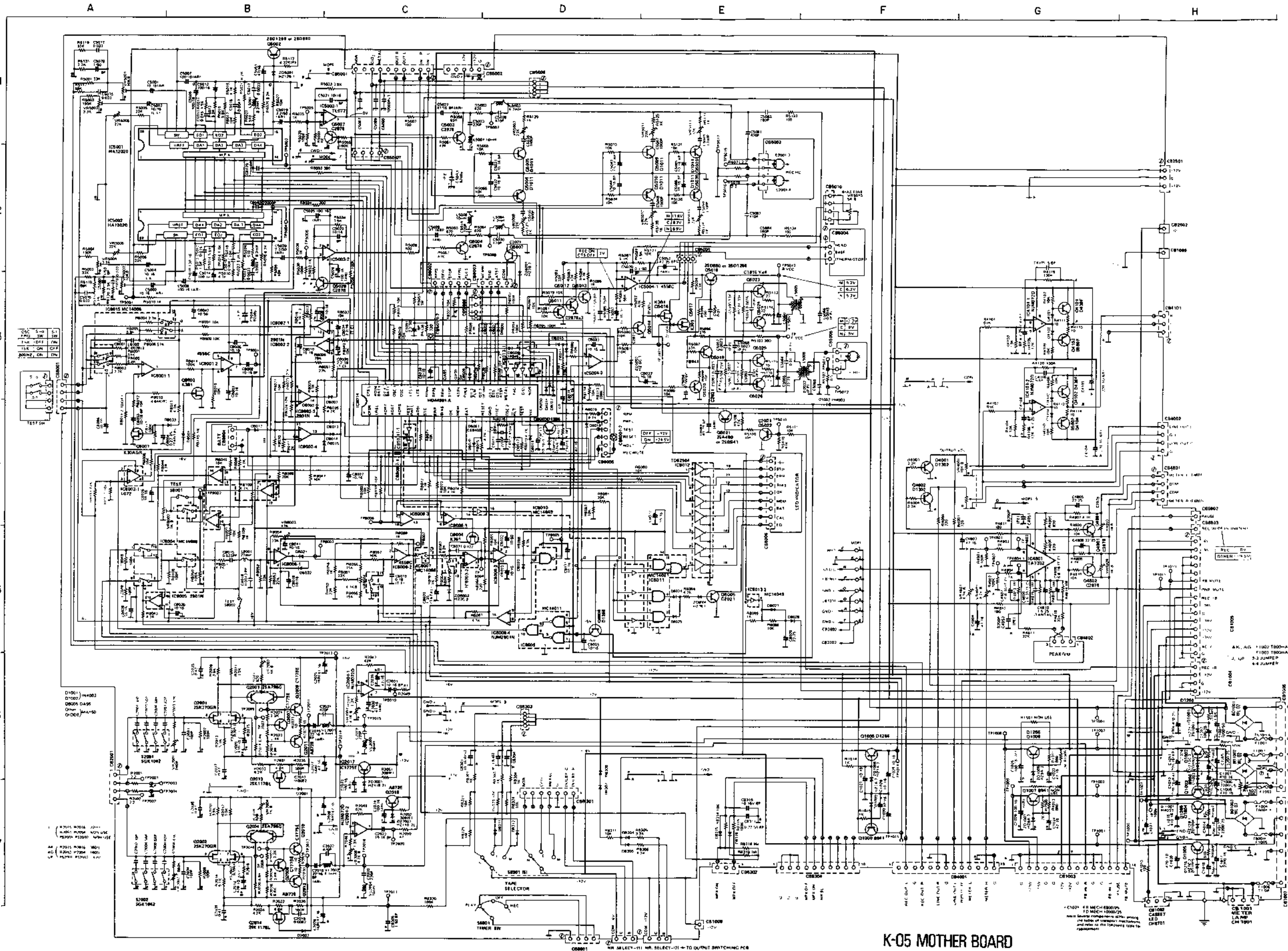

K-05 MOTHER BOARD

Schematic Diagram(3)

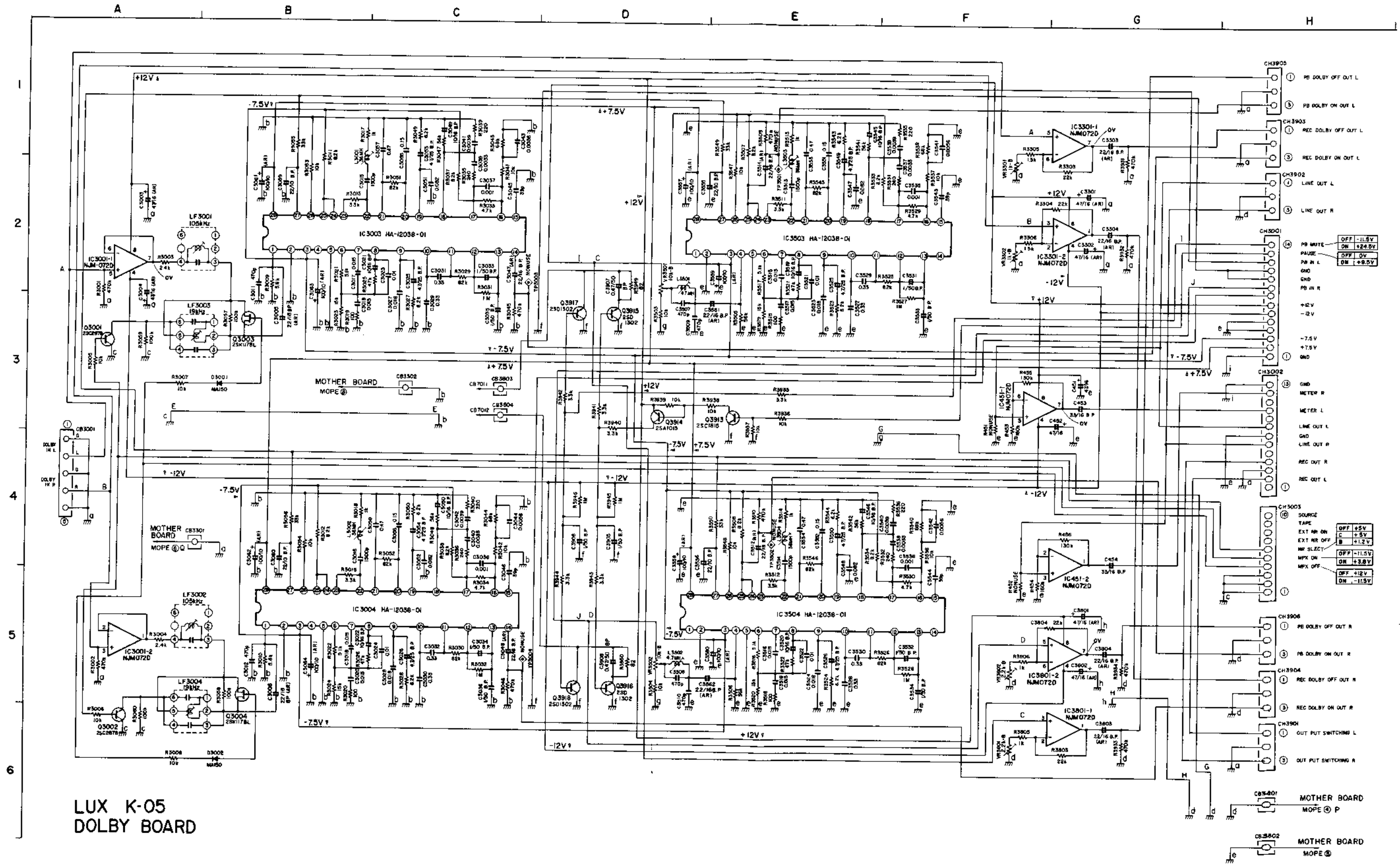

Schematic Diagram (4)

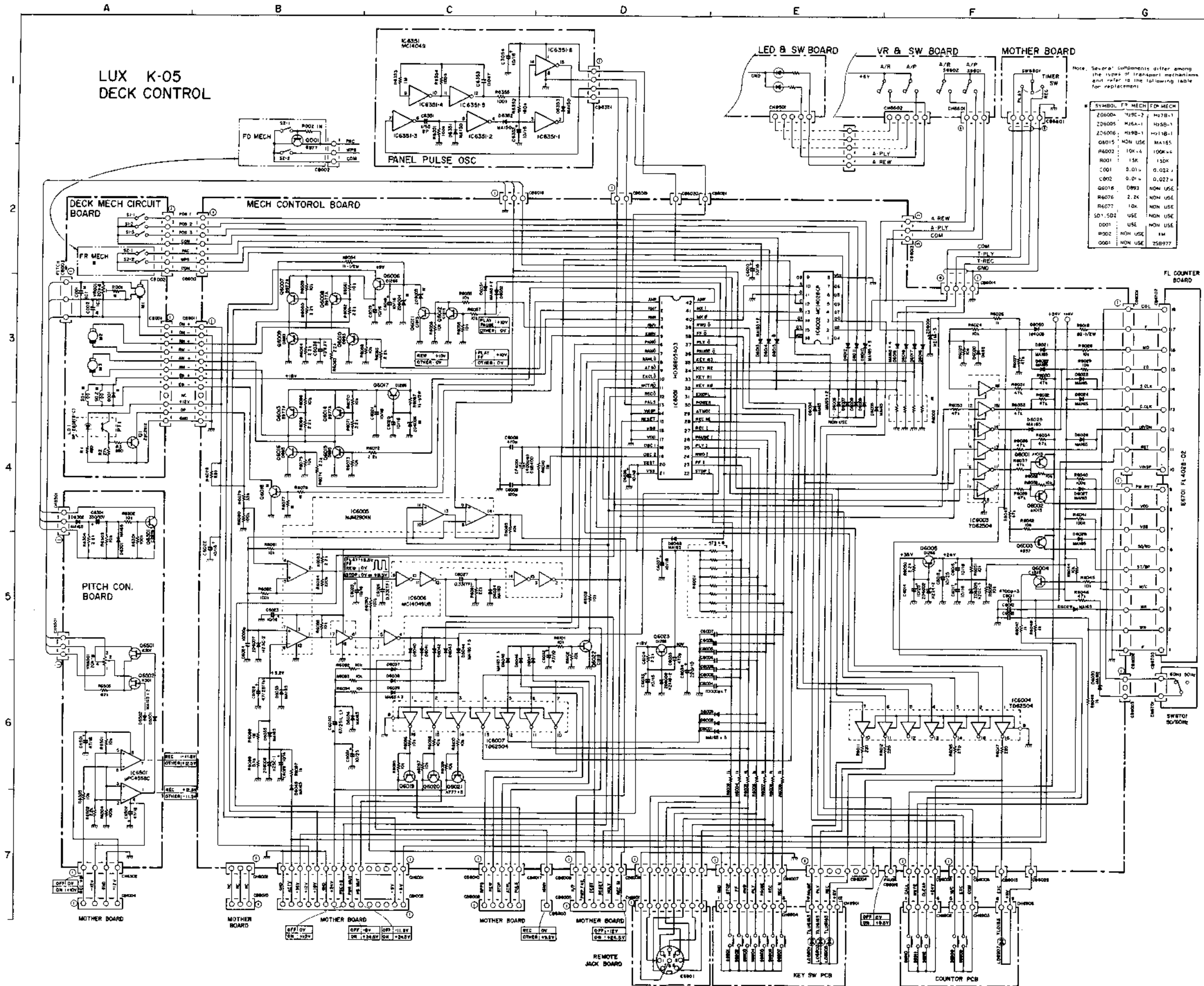

Note: Several components differ among the types of transport mechanisms and refer to the following table for replacement.

SYMBOL	FR MECH	FM MECH
20600A	229C-2	H37B-1
20600B	M3A-1	H35B-1
20600C	H39B-1	H31B-1
60015	NON USE	MA165
R6002	10K-4	100K-4
R001	15K	15K
C001	0.01-4	0.022-4
C002	0.01-4	0.022-4
Q6016	D893	NON USE
R6076	2.2K	NON USE
R6077	10K	NON USE
D015D2	USE	NON USE
D001	USE	NON USE
R002	NON USE	1M
Q001	NON USE	25B977

Schematic Diagram(5)

K-04,05 HEAD ERASER CIRCUIT

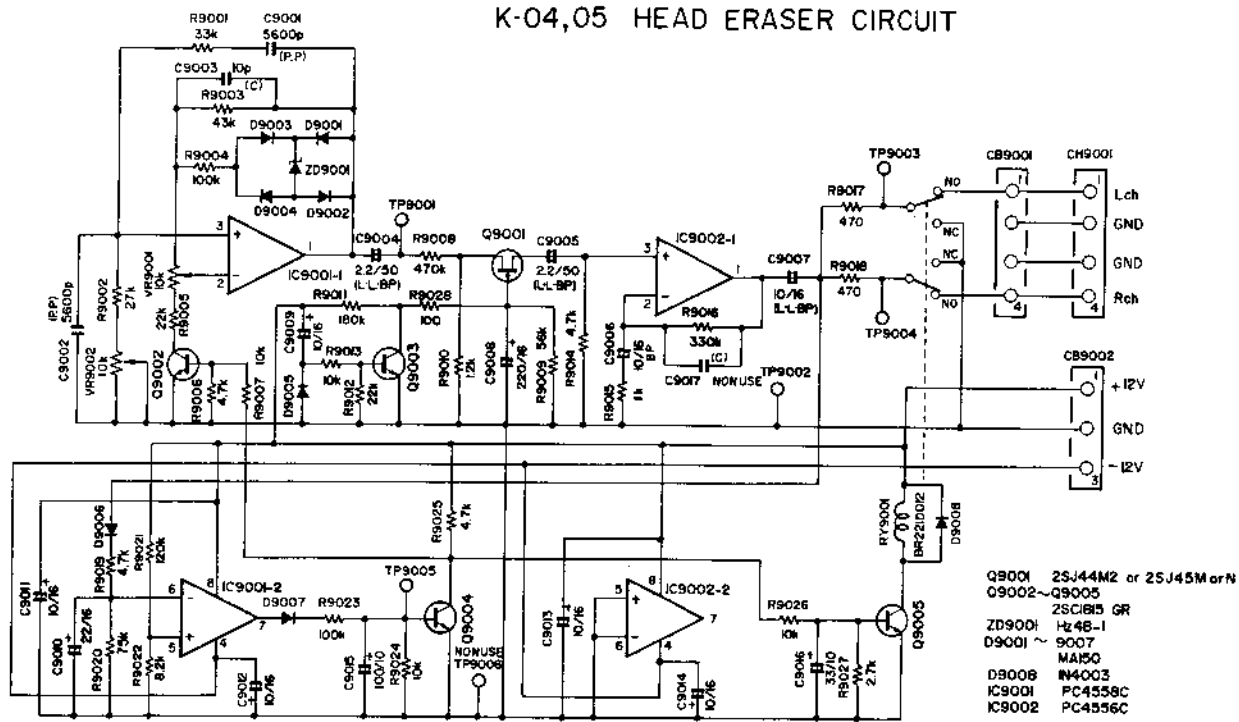

Specifications

Heads:	3
Record head	Sendust
Playback head	Ferrite
Erase head	Double Gap Sendust Ferrite
Wow & Flutter (W.R.M.S.):	0.022%
Signal-to-Noise Ratio:	
(C.C.I.R. weighted)	
Metal Tape, without NR	60dB
Metal Tape, with Dolby-B-NR	67dB
Metal Tape, with Dolby-C-NR	73dB
CrO ₂ Tape, without NR	58dB
CrO ₂ Tape with Dolby-B-NR	66dB
CrO ₂ Tape with Dolby-C-NR	73dB
Normal Tape without NR	56dB
Normal Tape with Dolby-B-NR	64dB
Normal Tape with Dolby-C-NR	71dB
Frequency Response:	
Metal Tape	15Hz-27,000Hz (20Hz-22,000Hz ± 2dB)
CrO ₂ Tape	15Hz-22,000Hz (20Hz-21,000Hz ± 3dB)
Normal Tape	15Hz-22,000Hz (20Hz-20,000Hz ± 3dB)
Tape 3rd Harmonic Distortion:	
(Normal Tape, 1KHz, 0dB)	0.5%
Input Sensitivity:	line in: 100mV
Output Level:	line out: 550mV
	headphone: 50mW (8 ohms load)
Power Consumption:	40W
Dimensions:	460(W) x 361(D) x 158(H)
	(18.1" x 14.2" x 6.2")
Weight:	Net: 11.5kg (25.3 lbs)
	Gross: 13.0kg (28.6 lbs)

Specifications and appearance design subject to change without notice.
 * NOISE REDUCTION CIRCUIT MADE UNDER LICENCE FROM DOLBY LABORATORIES. THE WORD "DOLBY" AND THE DOUBLE-D SYMBOL ARE THE TRADE MARKS OF DOLBY LABORATORIES.

K-05 OUTPUT SWITCHING PCB

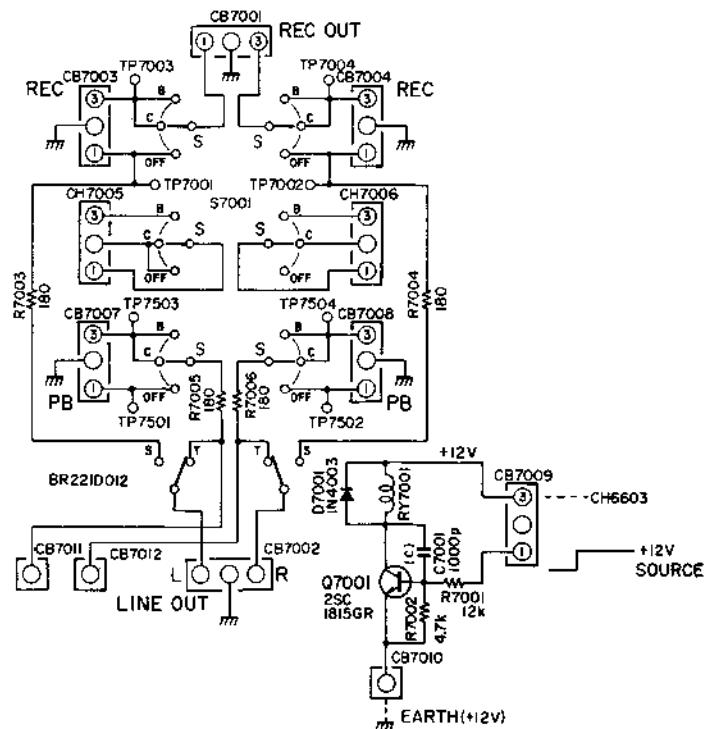

規 格

トラック形式	4トラック・2チャンネル・ステレオ方式
ヘッド構成	録再；センダスト／フェライト コンビ録再ヘッド 消去；デュアル・ギャップ／センダスト接合ヘッド
使用テープ	ノーマル・テープ、クローム・テープ、メタル・テープ
テープ速度	4.76cm/sec.
モーター構成	キャプスタン用；DD FG SERVO DC×1 リール用；DC×1 ヘッドハウジングリフト用；DC×1
操作方式	ソフトタッチ・ロジック・コントロール方式
ワウ&フラッター	0.022%以下 (W. R. M. S.)
巻き取り時間	80秒以下 (C60にて、FF・REWとも)
周波数特性	15～27,000Hz (20～22,000Hz±1.5dB)；メタルテープ 15～22,000Hz (20～20,000Hz±1.5dB)；クローム・テープ 15～22,000Hz (20～20,000Hz±1.5dB)；LHテープ
総合歪率	1.2%以下 (LHテープ, 1kHz, 0dB) 0.5%以下 (Real Analyzed Distortion, LHテープ, 1 kHz)
S N 比	60dB 以上 (ドルビー off, JIS-A 補正)；メタル・テープ 67dB 以上 (ドルビー B, CCIR 補正)；メタル・テープ 73dB 以上 (ドルビー C, CCIR 補正)；メタル・テープ 58dB 以上 (ドルビー off, JIS-A 補正)；クローム・テープ 66dB 以上 (ドルビー B, CCIR 補正)；クローム・テープ 73dB 以上 (ドルビー C, CCIR 補正)；クローム・テープ 56dB 以上 (ドルビー off, JIS 補正)；LHテープ 64dB 以上 (ドルビー B, CCIR 補正)；LHテープ 71dB 以上 (ドルビー C, CCIR 補正)；LHテープ
入カ	ライン；100mv
出カ	ライン；550mv ヘッドホン；50mw／8 Ω 負荷
付属機能	レコーディング・ミュート機能、オートスペース機能、オート・リワインド機能、オート・プレイ機能、バイアス&イコライザー・コンピュータ・チューニングシステム、データメモリ機能、Peak/VU 切替ニードル・メータ、タイマー録再機能、ドルビー NR システム、リモート操作可能、ヘッドホン・ジャック、ピッチコントロール、キュー／レビー機能、オート・イレース機能、マスター・フェーダー、ライン・フェーズ・センサ、バイアス・ファイン機能
電源	AC100V (50Hz/60Hz)
消費電力	40W
外形寸法	460 (幅)×158 (高)×361 (奥) mm
重量	11.5kg

*ドルビーおよび DD マークは、ドルビー・ラボラトリーズ・インコーポレーテッドの商標です。

*ドルビー・システムは、ドルビー・ラボラトリーズ・インコーポレーテッドの実施権に基づき製造されています。

K-05