

# SERVICE MANUAL

**NAD**

**T 770**

**SURROUND SOUND  
AV RECEIVER**

**T 770**

**SURROUND SOUND  
AV RECEIVER**

# SERVICE SAFETY PRECAUTIONS

## 1. Replacing the fuses

CAUTION: FOR CONTINUED PROTECTION AGAINST THE RISK OF FIRE  
REPLACE ONLY WITH SAME TYPE OF FUSE.

Reference No.	Part No.	Description
F901, F915, F916*AH	252166	6.3A-125V UL/T-237 Time lag
F902*B1, B, C	252077	T4AL/250V SE-EAK Time lag
F915, F916*B1, B, C	252079	T6.3AL/250V SE-EAK Time lag

### NOTE:

<\*AH> : U.S.A. , CANADIAN MODEL ONLY.

<\*B1> : AUSTRALIAN MODEL ONLY.

<\*C> : EUROPEAN MODEL ONLY.

<\*B> : U. K. MODEL ONLY.

## 2. Safety Check out

(Only U.S.A. model)

Before returning the product to the customer, make leakage current or resistance measurements to determine that exposed parts are acceptably insulated from the supply circuit.

Parts marked with the symbol  $\triangle$  are critical with regard to the risk of fire and electric shock. Replace only with parts recommended by the manufacturer.

# CONTENTS

DESCRIPTION	PAGE
SERVICE SAFETY PRECAUTIONS.....	2
FRONT PANEL / REAR PANEL VIEW.....	3
SPECIFICATIONS.....	4
AUDIO SECTION BLOCK DIAGRAM.....	5
POWER SUPPLY SECTION BLOCK DIAGRAM.....	6
VIDEO SECTION BLOCK DIAGRAM.....	7
TUNER SECTION BLOCK DIAGRAM.....	8
ADJUSTMENT POINTS.....	9
PCB LAYOUT.....	10-16
SCHEMATIC DIAGRAM.....	17-23
MICROPROCESSOR CONNECTION DIAGRAM.....	24-25
SUB MICROPROCESSOR CONNECTION DIAGRAM.....	26
SUB MICROPROCESSOR PIN DESCRIPTION.....	27
IC BLOCK DIAGRAMS AND PIN DESCRIPTION.....	28-37
WIRING DIAGRAM.....	38
ELECTRICAL PARTS LIST.....	39-46
EXPLODED VIEW.....	47
EXPLODED VIEW PARTS LIST.....	48-49
PACKING DIAGRAM / PARTS LIST.....	50
COUNTERMEASURE FOR DVD NOISE.....	51

# FRONT PANEL CONTROLS

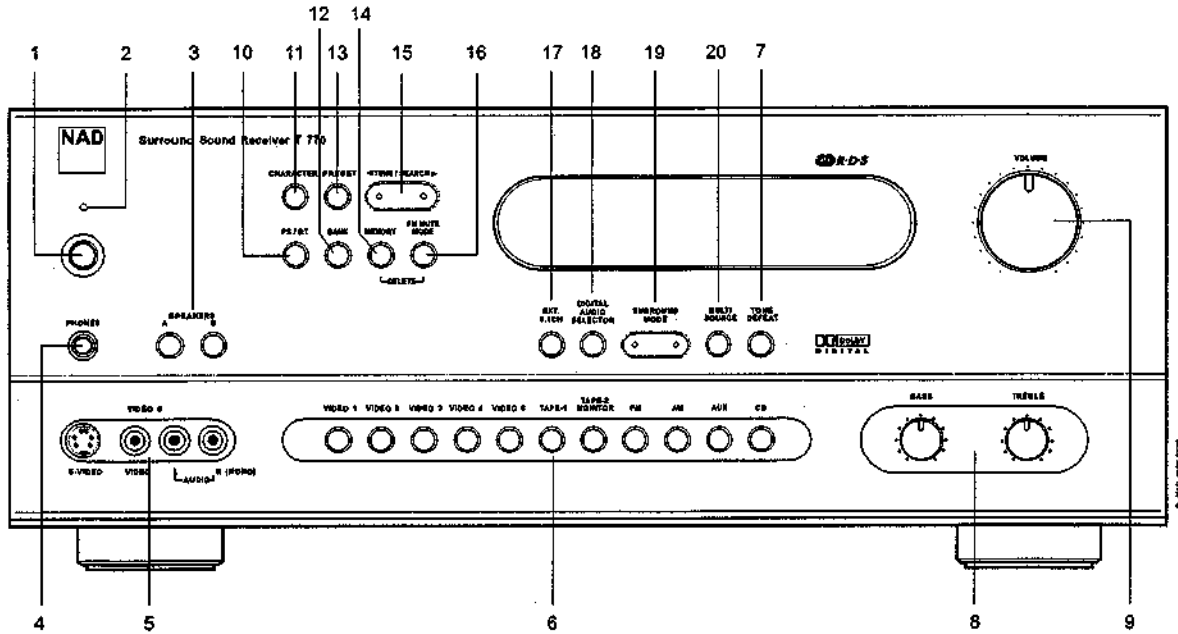

- |                     |  |                  |                            |
|---------------------|--|------------------|----------------------------|
| 1. POWER            | 7. TONE DEFEAT                           | 12. BANK         | 17. EXT. 5.1 CH            |
| 2. STANDBY LED      | 8. BASS & TREBLE CONTROLS                | 13. PRESET       | 18. DIGITAL AUDIO SELECTOR |
| 3. SPEAKERS A, B    | 9. VOLUME                                | 14. MEMORY       | 19. SURROUND MODE          |
| 4. HEADPHONE SOCKET | 10. DISPLAY FOR AH, PS/RT FOR (B, B1, C) | 15. TUNE/SEARCH  | 20. MULTI SOURCE           |
| 5. VIDEO 5 INPUT    | 11. CHARACTER                            | 16. FM MUTE MODE |                            |



The lightning flash with arrowhead, within an equilateral triangle is intended to alert the user of the presence of uninsulated "dangerous voltage" within the product's enclosure; that may be of sufficient magnitude to constitute a risk of electric shock to persons.



The exclamation point within an equilateral triangle is intended to alert the user of the presence of important operating and maintenance (servicing) instructions in the literature accompanying the appliance.

# REAR PANEL CONNECTIONS

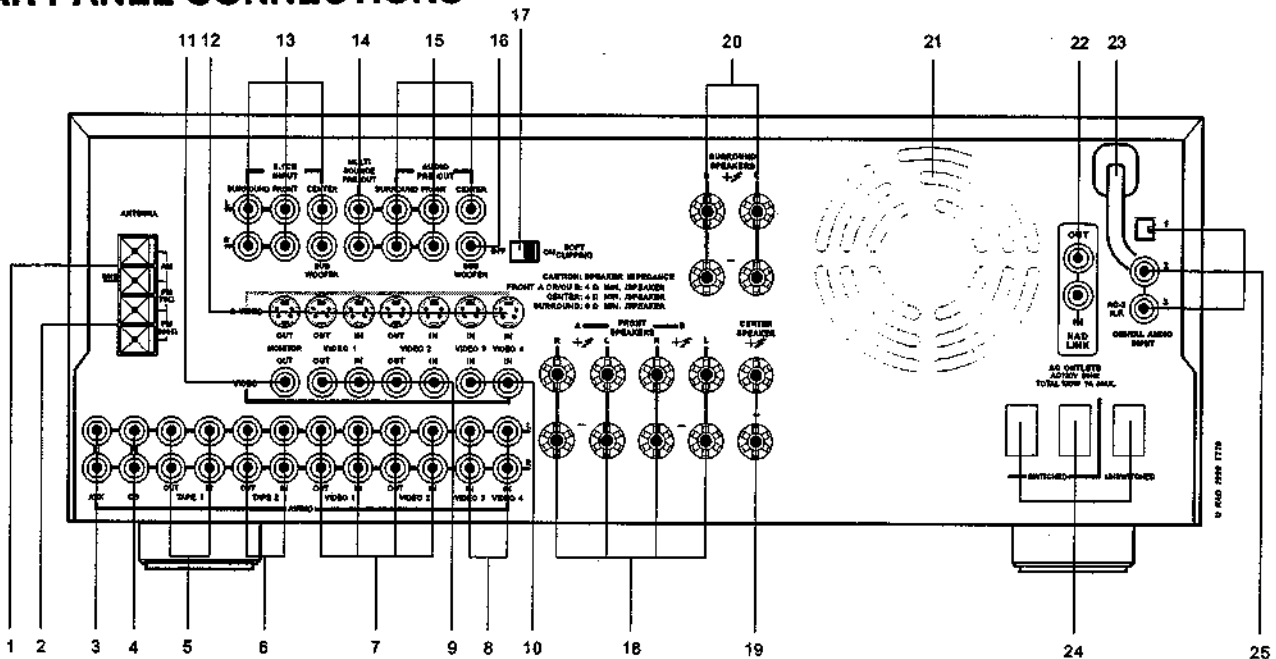

- |  |   |                          |                          |
|--|---|--------------------------|--------------------------|
| 1. AM ANTENNA  | 7. VIDEO 1 & VIDEO 2 (AUDIO)                            | 13. 5.1 CHANNEL INPUTS   | 20. SURROUND SPEAKERS    |
| 2. FM ANTENNA (SPRING CLIP FOR AH, DIN FOR B, B1, C) | 8. VIDEO 3 & VIDEO 4 (AUDIO)                            | 14. MULTI SOURCE PRE-OUT | 21. COOLING FAN          |
| 3. AUX INPUT   | 9. VIDEO 1 & VIDEO 2 (VIDEO)                            | 15. AUDIO PRE-OUT        | 22. NAD-LINK IN OUT      |
| 4. CD INPUT  | 10. VIDEO 3 & VIDEO 4 (VIDEO)                           | 16. SUBWOOFER OUT        | 23. AC POWER CORD        |
| 5. TAPE 1  | 11. MONITOR OUT   | 17. SOFT CLIPPING        | 24. AC OUTLETS (AH ONLY) |
| 6. TAPE 2  | 12. S-VIDEO VIDEO 1, VIDEO 2, VIDEO 3, VIDEO 4, MONITOR | 18. FRONT SPEAKERS A & B | 25. DIGITAL AUDIO INPUTS |
|  |   | 19. CENTER SPEAKER       |                          |

# SPECIFICATIONS

## Test conditions

Power Supply Voltage & Frequency  
 AM Type -----120V / 60Hz  
 C/B/B1 Type -----230V / 50Hz  
 Load Resistance  
 Speaker Terminal -----8 ohms  
 Other Terminal -----47k ohms  
 Temperature & Humidity  
 Temperature ----- 5 ~ 35 °C  
 Humidity ----- 45 ~ 85 %

## <Amplifier section>

L&R Max. Power  
 8 ohms 70W 20Hz / 1kHz / 20kHz  
 4 ohms 70W Both Channel Driven  
 Line Hum & Noise -60.0dBV Terminated With 5.1kΩ  
 Line Separation  
 100Hz 67.0dB Terminated With 5.1kΩ  
 10kHz 45.0dB  
 Line Distortion  
 20kHz 0.15%

## DSP Gain (ADC INPUT)

1kHz 6.5±1.0dBV L/R/C-SP  
 1kHz 6.5±1.0dBV LS/RS-SP  
 -23.0±1.0dBV L/R/C-PO  
 20Hz -4.0±1.5dBV SW-PO

## L&R&C MAX. Power

8 ohms 1kHz 70W L/R/C-SP, 3ch Only Driven  
 4 ohms 1kHz 70W L/R/C-SP, 3ch Only Driven  
 Surround Mode MAX. Power  
 8 ohms 1kHz 70W THD=0.1%  
 6 ohms 1kHz 50W THD=0.3%

DSP THD 1kHz 0.12% L/R-SP  
 1kHz 0.12% C/LS/RS-SP  
 20Hz 0.1% SW-PO

## AC-3 Decoder gain

1kHz 8.5±1.5dBV L/R-SP  
 8.5±1.5dBV C/LS/RS-SP  
 30Hz -3.0±1.5dBV SW-PO

## COAXIAL Gain

1kHz 8.5±1.5dBV L/R-SP

## OPT. Gain

1kHz 9.0±1.5dBV LS/RS-SP

## Tone Gain

1kHz -3.7±1.5dBV L-SP Master Volume: -24dB  
 -3.7±1.5dBV R-SP  
 -3.7±1.5dBV C-SP

## Bass Max.

100Hz +8.0±1.0dBV L-SP Master Volume: -24dB, Bass Max.  
 +8.0±1.0dBV R-SP  
 +8.0±1.0dBV C-SP

## Bass Min.

100Hz +8.0±1.0dBV L-SP Master Volume: -24dB, Bass Min.  
 +8.0±1.0dBV R-SP  
 +8.0±1.0dBV C-SP

## Treble Max.

10kHz +8.5±1.0dBV L-SP Master Volume: -24dB, Treble Max.  
 +8.5±1.0dBV R-SP  
 +8.5±1.0dBV C-SP

## Treble Min.

10kHz +8.5±1.0dBV L-SP Master Volume: -24dB, Treble Min.  
 +8.5±1.0dBV R-SP  
 +8.5±1.0dBV C-SP

## <Tuner section>

### (AM)

Tuning Range 530 / 522 kHz  
 1710 / 1611 kHz Fmax. AH/C, B, B1  
 Frequency step AH / C, B, B1 = 10 / 9kHz  
 Change the AM freq. step.

	To 9kHz step	To 10kHz step
R1721	10k ohm	4.7k ohm
R1720	-	3.9k ohm

Intermediate Frequency 450 ± 0.01kHz  
 Maximum Sensitivity 70 dB/m 603, 990, 1404 kHz  
 Usable Sensitivity 15 dB 603, 990, 1404 kHz  
 Image Rejection Ratio 28 dB min. 1404 / 1400 kHz  
 IF Rejection Ratio 40 dB min. 603 / 600 kHz  
 Signal to Noise Ratio 40 dB min. 990 kHz  
 Fixed Output Level 100 mV min. 990 kHz  
 T.H.D. 1.5 % max. 990 kHz

### (FM)

Tuning Range 87.5 MHz Fmin.  
 108.0 MHz Fmax.  
 Intermediate Frequency 10.7 ± 0.002MHz  
 Usable Sensitivity 30 dB min. 87.5, 98, 108 MHz  
 3dB Limited Sensitivity 6 dB μV max. 98 MHz  
 Image Rejection Ratio 35 / 70 dB min. 108 MHz (AH/C, B, B1)  
 IF Rejection Ratio 70 dB min. 90 MHz  
 Signal to Noise Ratio 65 dB min. 98 MHz  
 Fixed Output Level 500 ± 250 mV AH (98MHz)  
 700 ± 250 mV C, B, B1  
 T.H.D. 0.6 % max. Mono. (98MHz)  
 1.5 % max. Stereo  
 AM Suppression Ratio 45 dB min. 98 MHz  
 RDS Sensitivity 32dB μV max. 98 MHz, 1.0kHz Dev.

Available Remote

Operations : F770





# VIDEO SECTION BLOCK DIAGRAM

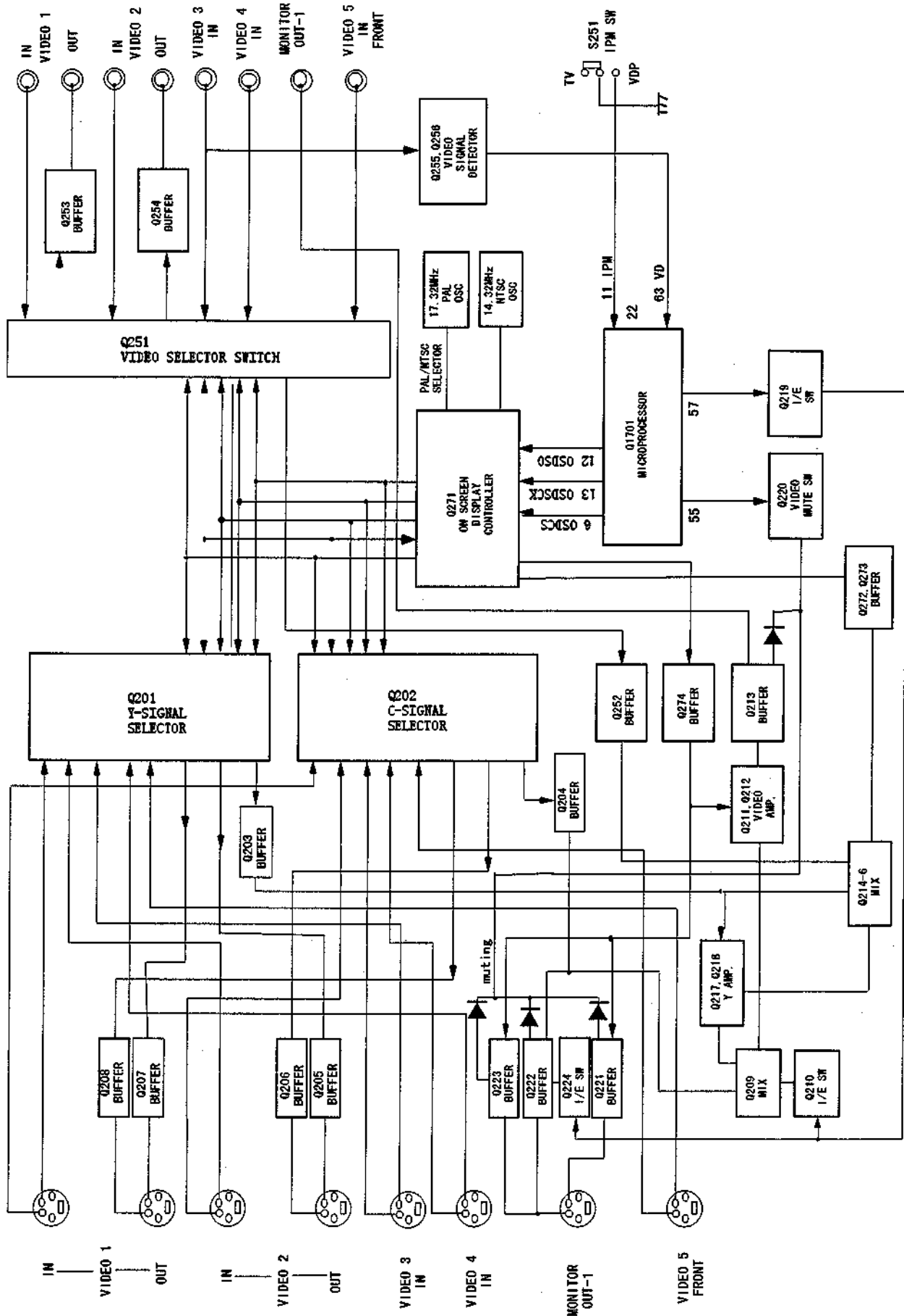

# TUNER SECTION BLOCK DIAGRAM

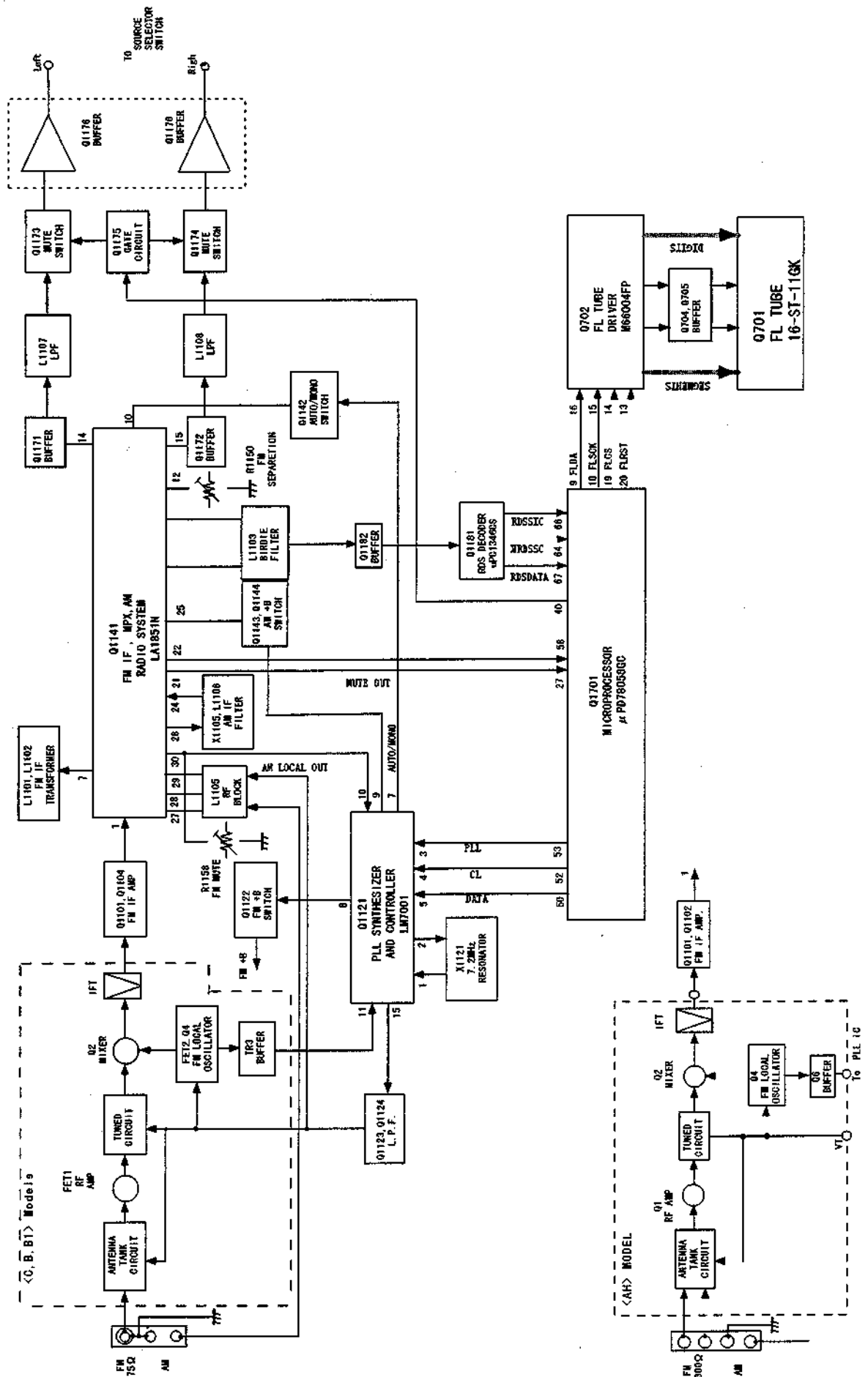



## ADJUSTMENT POINTS

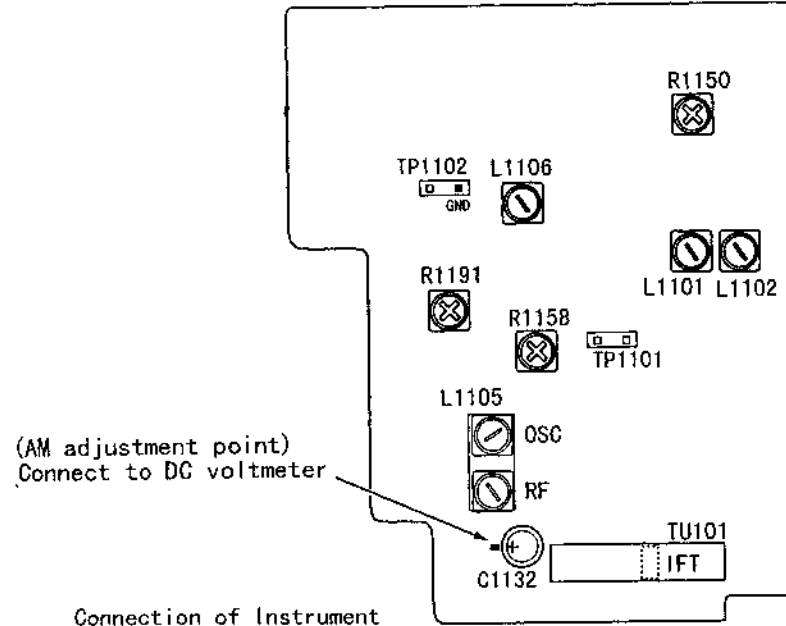

Connection of Instrument  
FM Adjustment

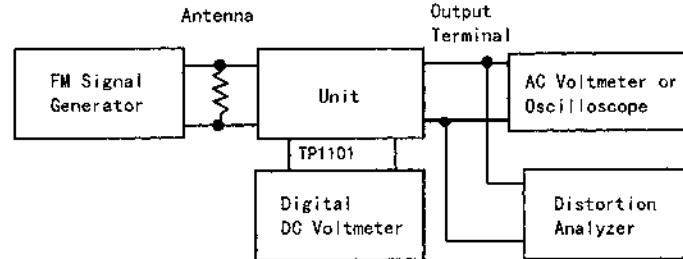

(Fig-1)

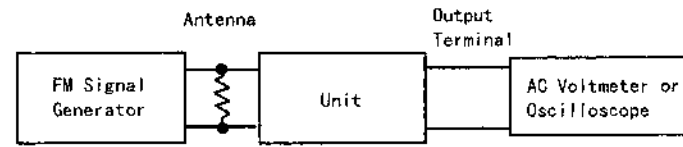

(Fig-2)

FM Stereo Adjustment

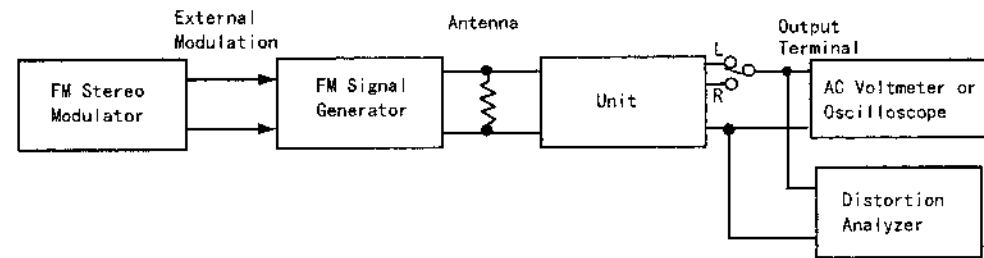

(Fig-3)

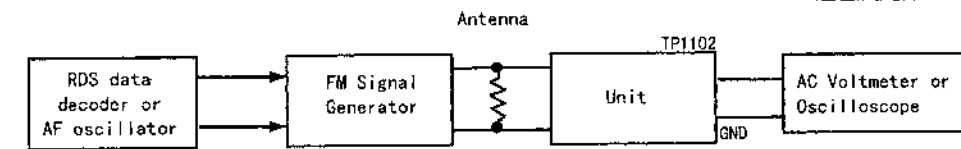

(Fig-4)

AM Adjustment

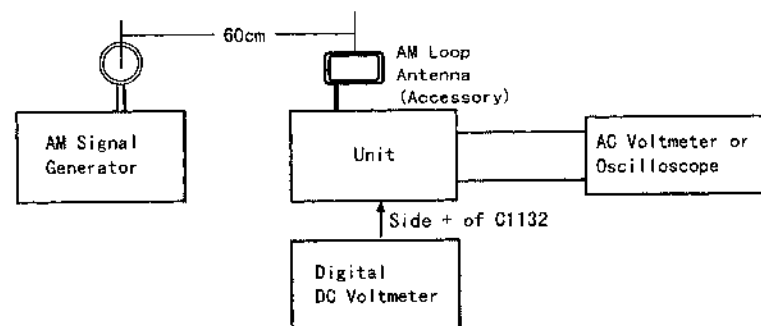

## ADJUSTMENT PROCEDURES

### Preparation

1. Input
  - FM mono : 1kHz, 75kHz devi., 60dB/μV
  - FM stereo: 1kHz, 67.5kHz devi., 60dB/μV
  - Pilot signal: 19kHz 7.5kHz devi.
  - AM : 400Hz, 30% mod.

### 2. Outputs

Connect the non-inductive type resistor of 8 ohms to the all speaker terminals unless otherwise noted.

### FM Adjustment

Item	Step	Connection of instrument	FM SG output	Stereo modulator output	Tuning frequency	Output indicator	Adjustment point	Adjust for	Remarks
FM IF/RF	1	Fig. 1	99.0MHz 1kHz 75kHz devi. 65dBf (60dBμ)	—	99.0MHz	DC voltmeter	L1101	0±20mV	FM MUTE/MODE switch: OFF/MONO Repeat the steps 1 and 3 until no further adjustment is necessary.
	AC voltmeter					IFT on the front end	Maximum		
	Distortion analyzer					L1102	Minimum		
Stereo Distortion		Fig. 3	99.0MHz Ext. mod. 65dBf (60dBμV)	Channel L or R 1kHz	99.0MHz	Distortion analyzer	IFT on the front end	Minimum	Don't turn more than ±180°
Stereo Separation	1	Fig. 3	99.0MHz Ext. mod. 65dBf (60dBμV)	Channel L 1kHz	99.0MHz	Channel R AC voltmeter	R1150	Minimum	Maximum and same separation
	2							Channel L AC voltmeter	
Muting Level		Fig. 2	99.0MHz 1kHz 22.5kHz devi. 19.2dBf (14dBμV)	—	99.0MHz	Oscilloscope	R1158	TUNED indicator lights on	
RDS		Fig. 4	98.0MHz Ext. mod. 65dBf (60dBμV)	RDS data or 57kHz 3% devi.	98.0MHz	Oscilloscope	R1191	Maximum	

### AM ADJUSTMENT

#### AH model

Step	AM SG output	Tuning Frequency	Output Indicator	Adjustment point	Adjust for
1		530kHz	Digital DC voltmeter	OSC coil on RF block L1105	1.4±0.2V
2	600kHz 400Hz 30% mod. 60dB/m	600kHz	AC voltmeter	RF coil on RF block L1105	Maximum
3		990kHz	AC voltmeter	L1106	Maximum

#### Reference Specification

FM tuned voltage: 87.50MHz ~ 108.00MHz  
More than 1.3V ~ Less than 9V  
AM tuned voltage: 530kHz ~ 1710kHz  
1.4V ±0.4 ~ Less than 9.0V

#### B, B1, C models

Step	AM SG output	Tuning Frequency	Output Indicator	Adjustment point	Adjust for
1		522kHz or 531kHz	Digital DC voltmeter	OSC coil on RF block L1105	1.4±0.2V
2	600kHz 400Hz 30% mod. 60dB/m	603kHz	AC voltmeter	RF coil on RF block L1105	Maximum
3		999kHz	AC voltmeter	L1106	Maximum

#### Reference Specification

FM tuned voltage: 87.50MHz ~ 108.00MHz  
More than 1.3V ~ Less than 9V  
AM tuned voltage: 522kHz ~ 1611kHz  
(230V model) 1.4V ±0.4 ~ Less than 9.0V  
AM tuned voltage: 531kHz ~ 1602kHz  
(Worldwide model) 1.4V ±0.4 ~ Less than 9.0V

PCB-20 : NAVD-6391 Composite video circuit PC board

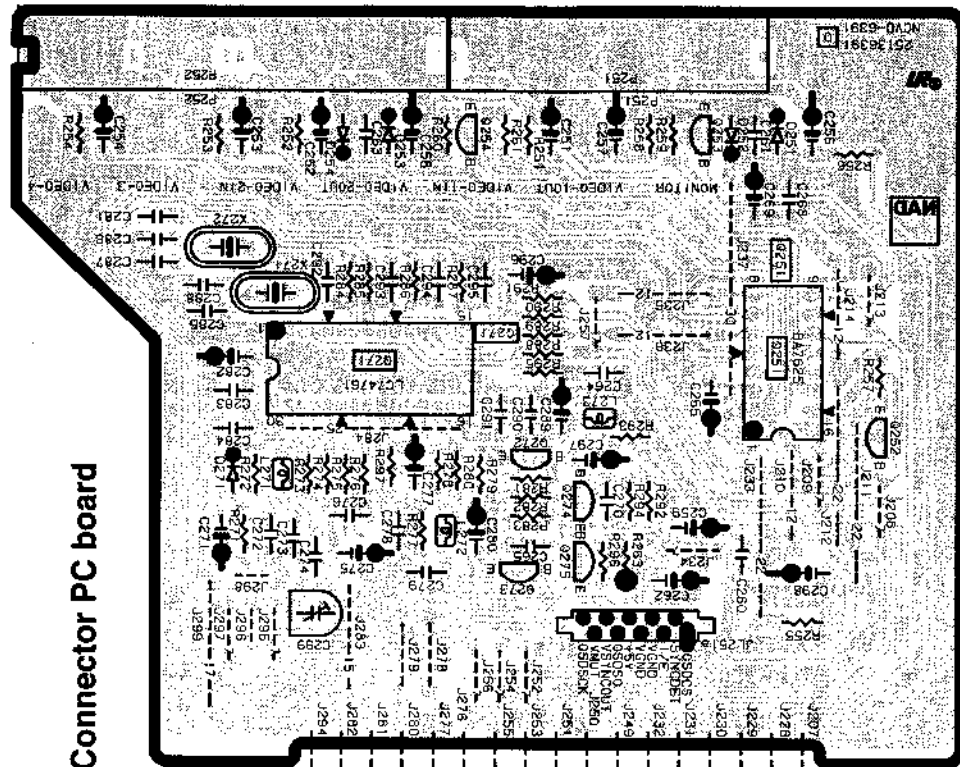

PCB-19 : NARF-6390 Tuner circuit PC board

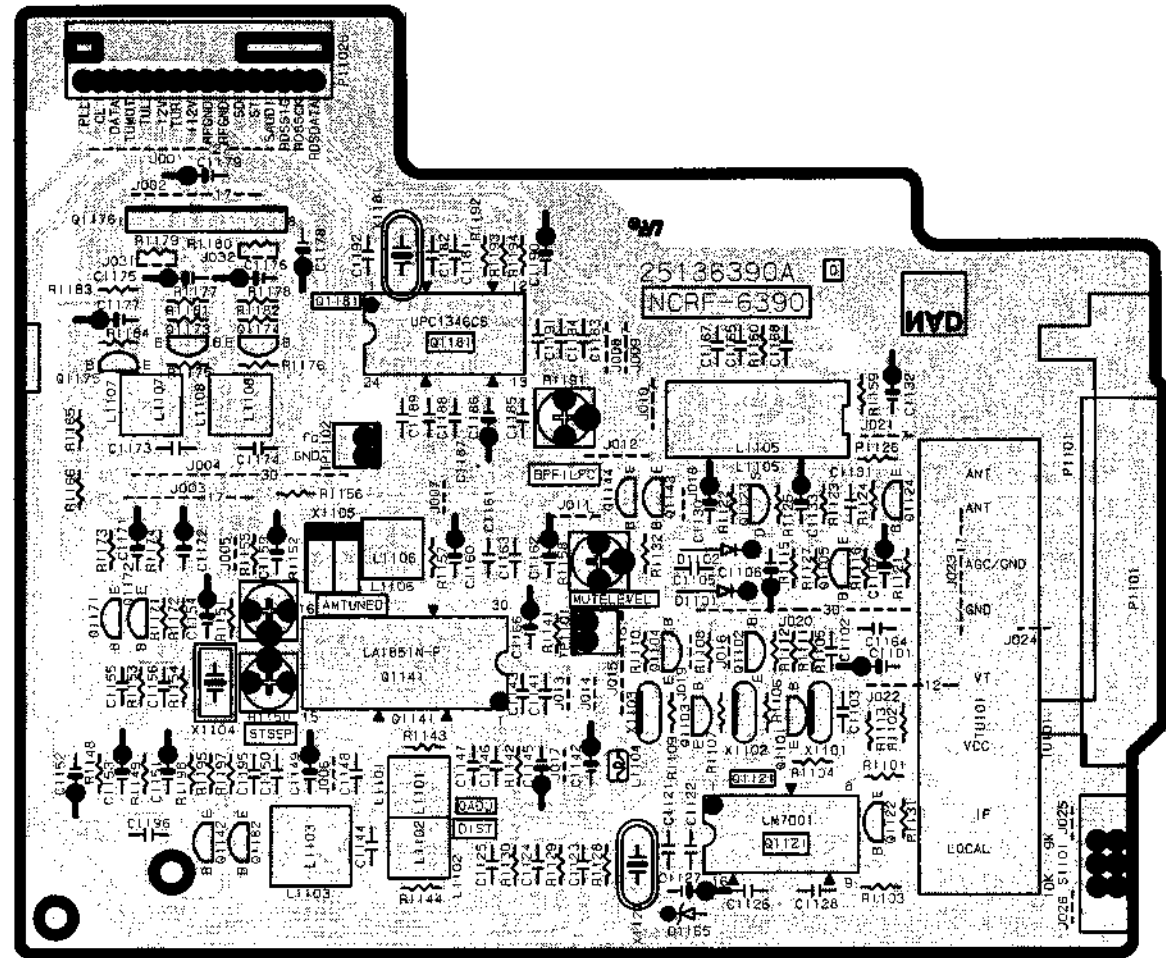

PCB-26 : NAETC-6393 Connector PC board

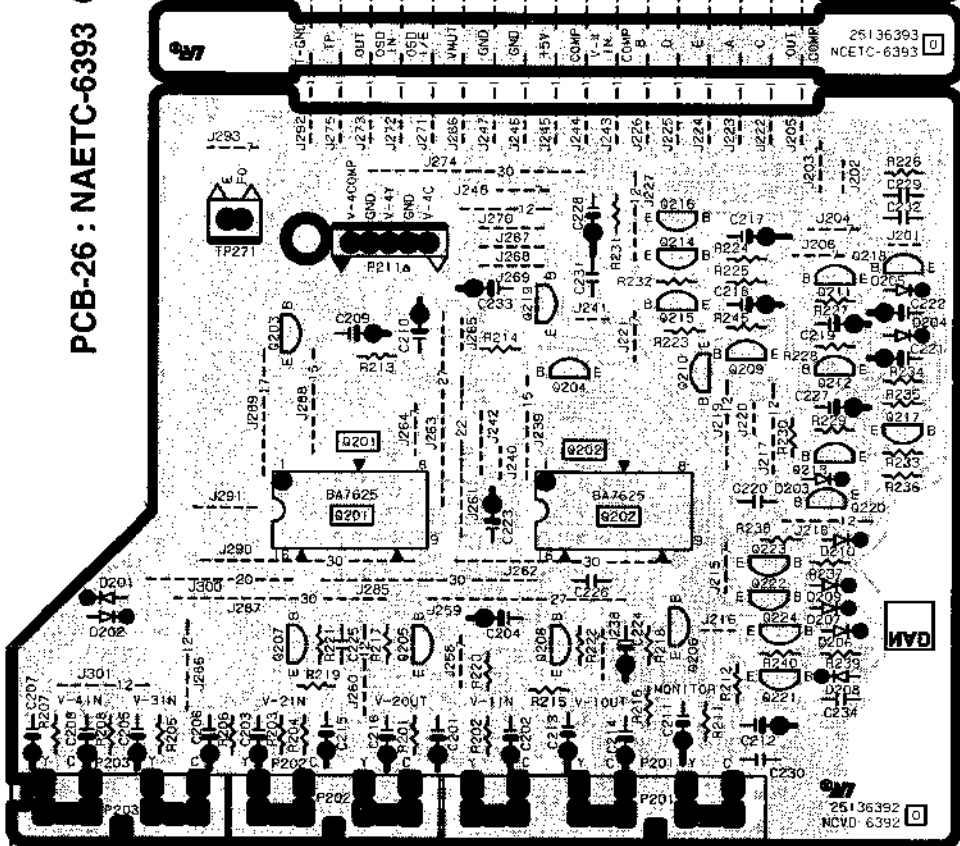

PCB-25 : NAETC-6394 Front video terminal PC board

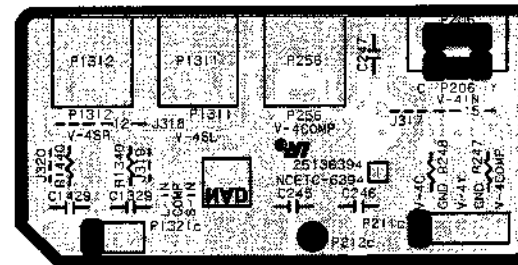

PCB-21 : NAVD-6392 Video circuit PC board



PCB-16 : NAAF-6387-1 Volume circuit PC board

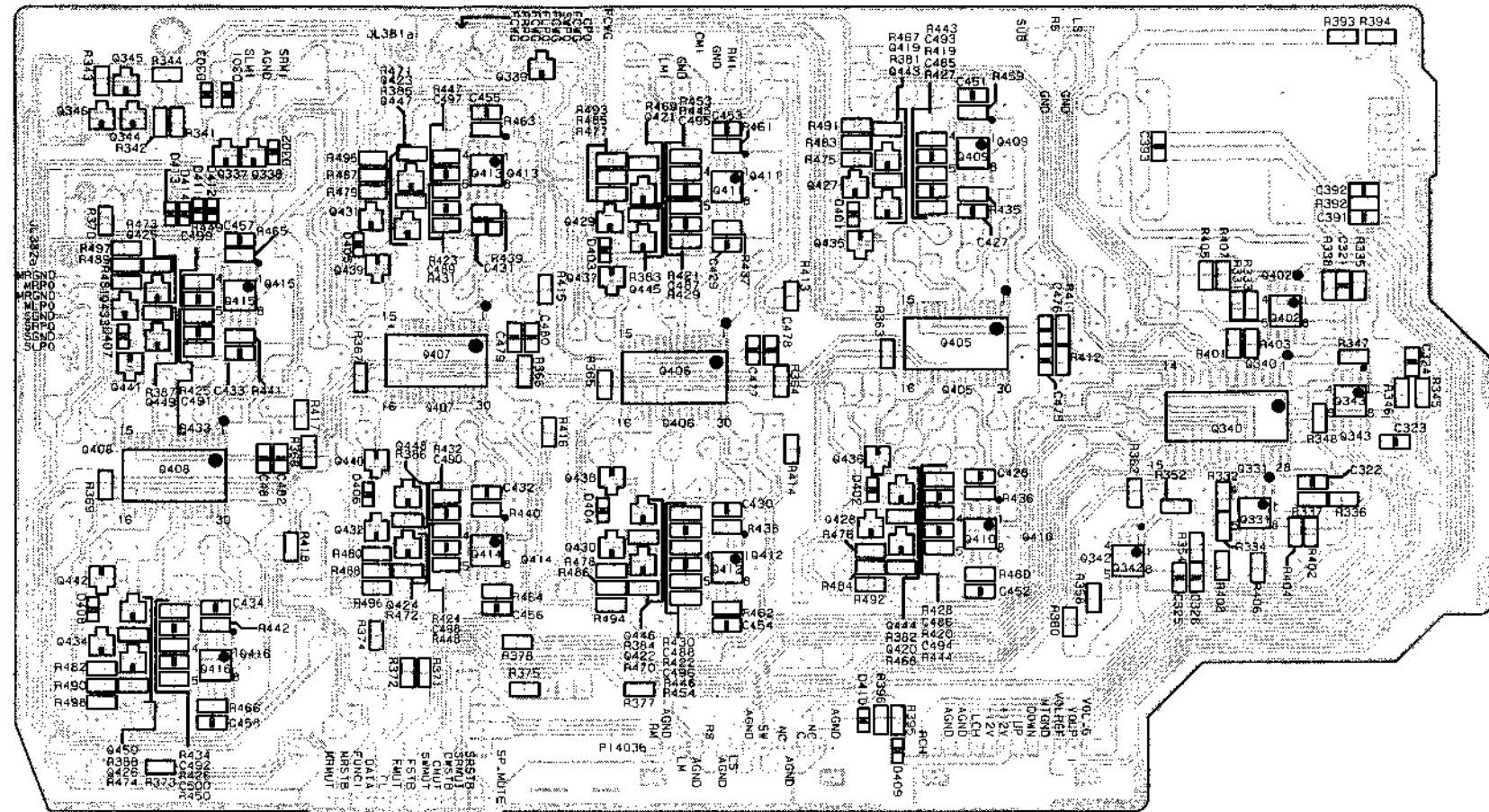

PCB-5 : NAAF-6409 Pre. output terminal PC board

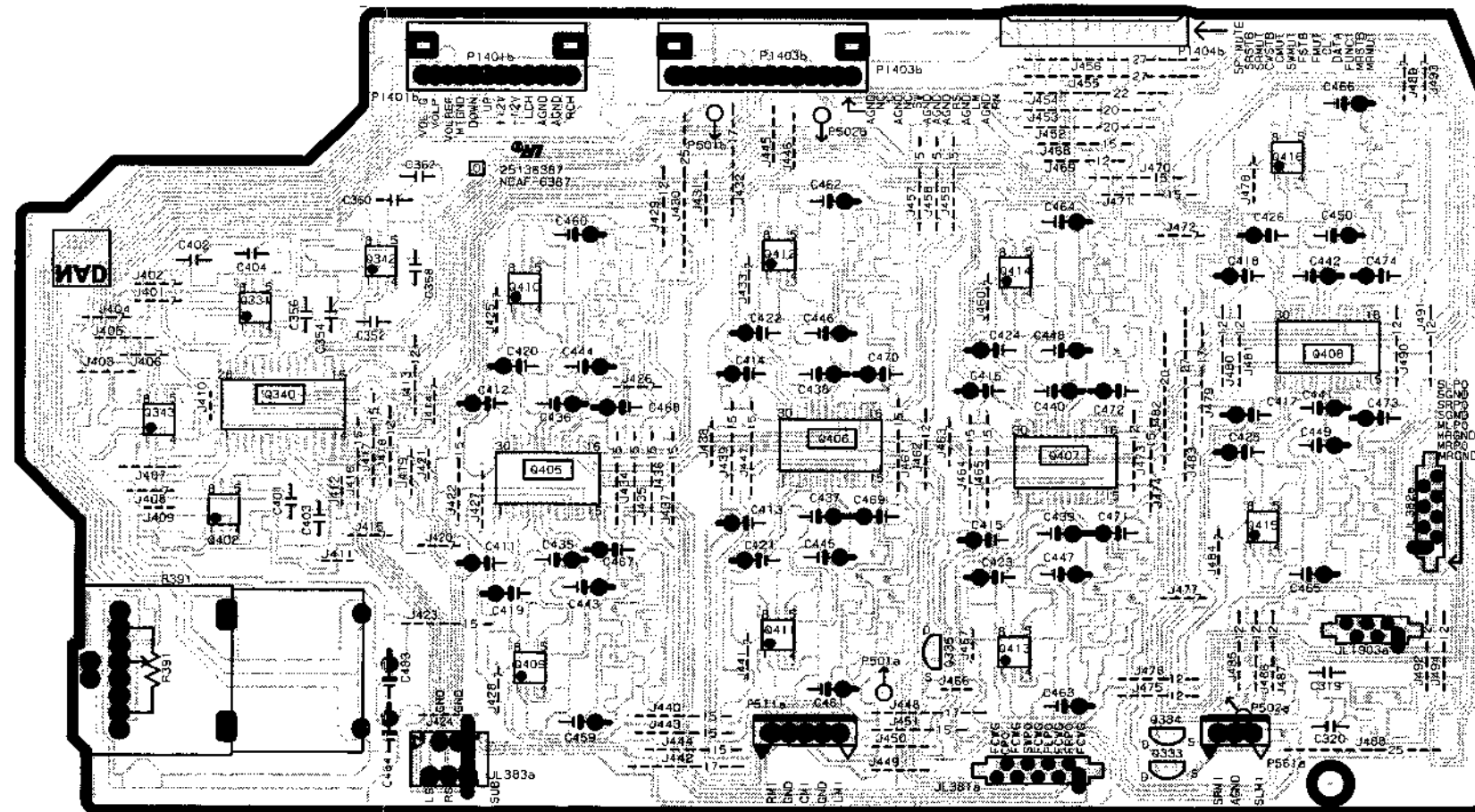
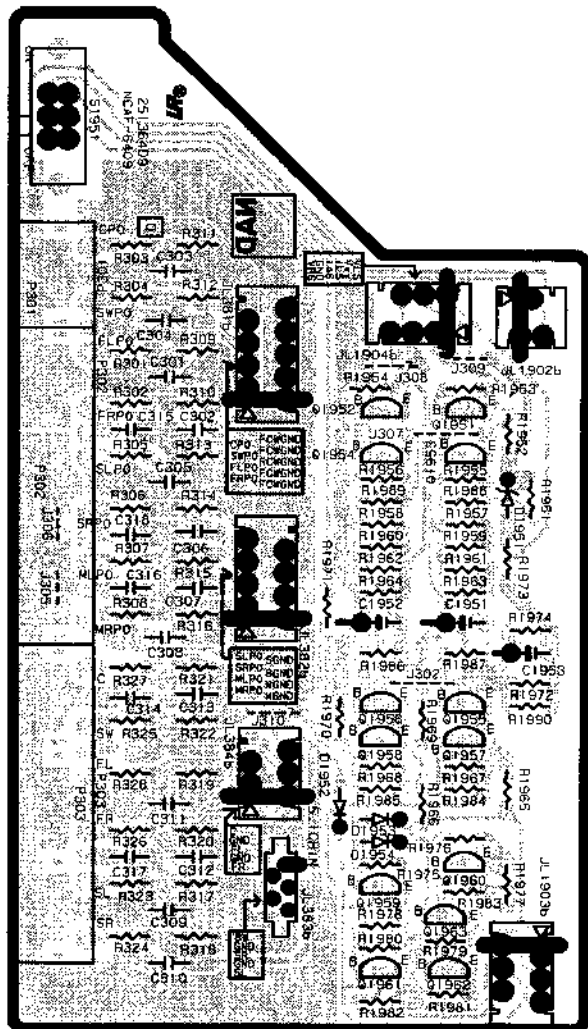



PCB-27 : NADG-6396 DSP circuit PC board

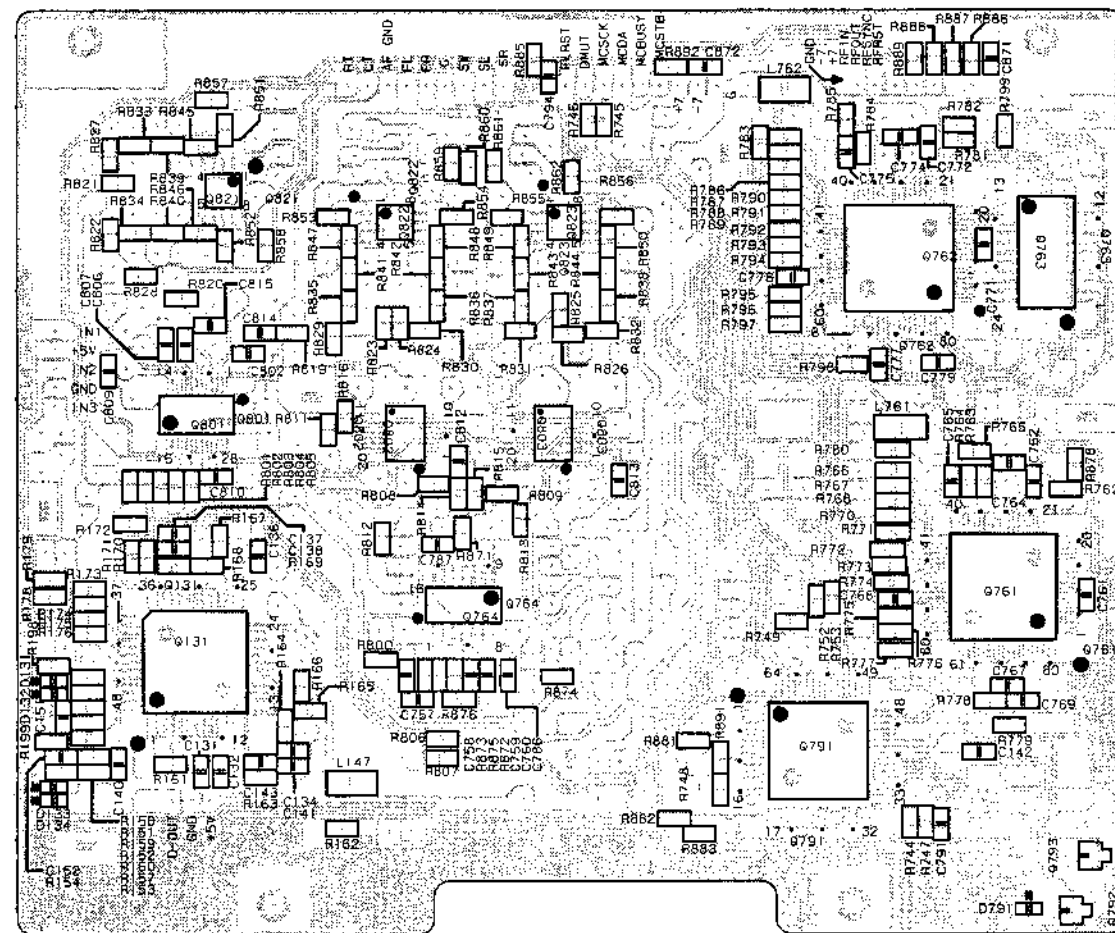

PCB-30 : NADG-6388 AC-3 circuit PC board

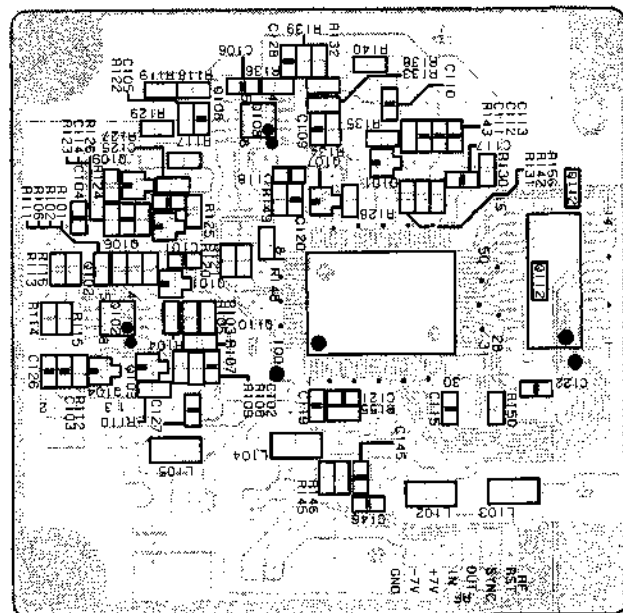

PCB-22 : NAETC-6395 Digital input terminal PC board

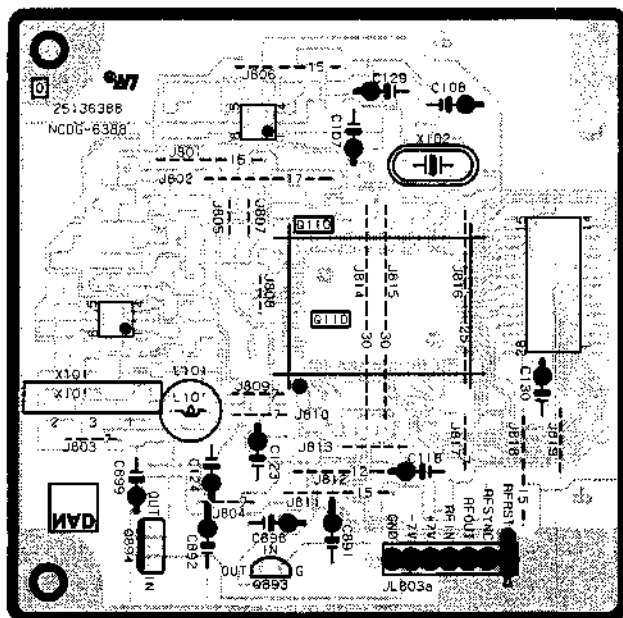
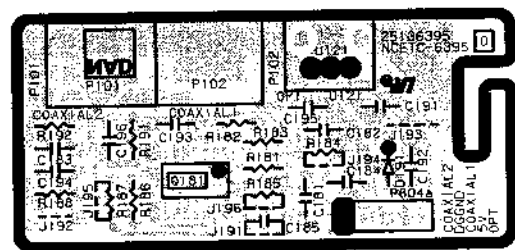

PCB-35 : NAETC-6516 DSP sub PC board

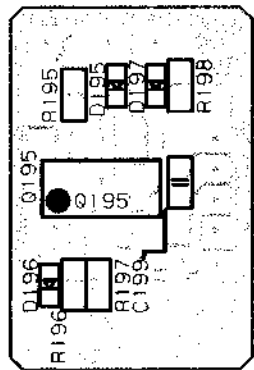
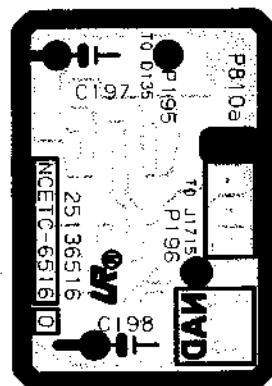
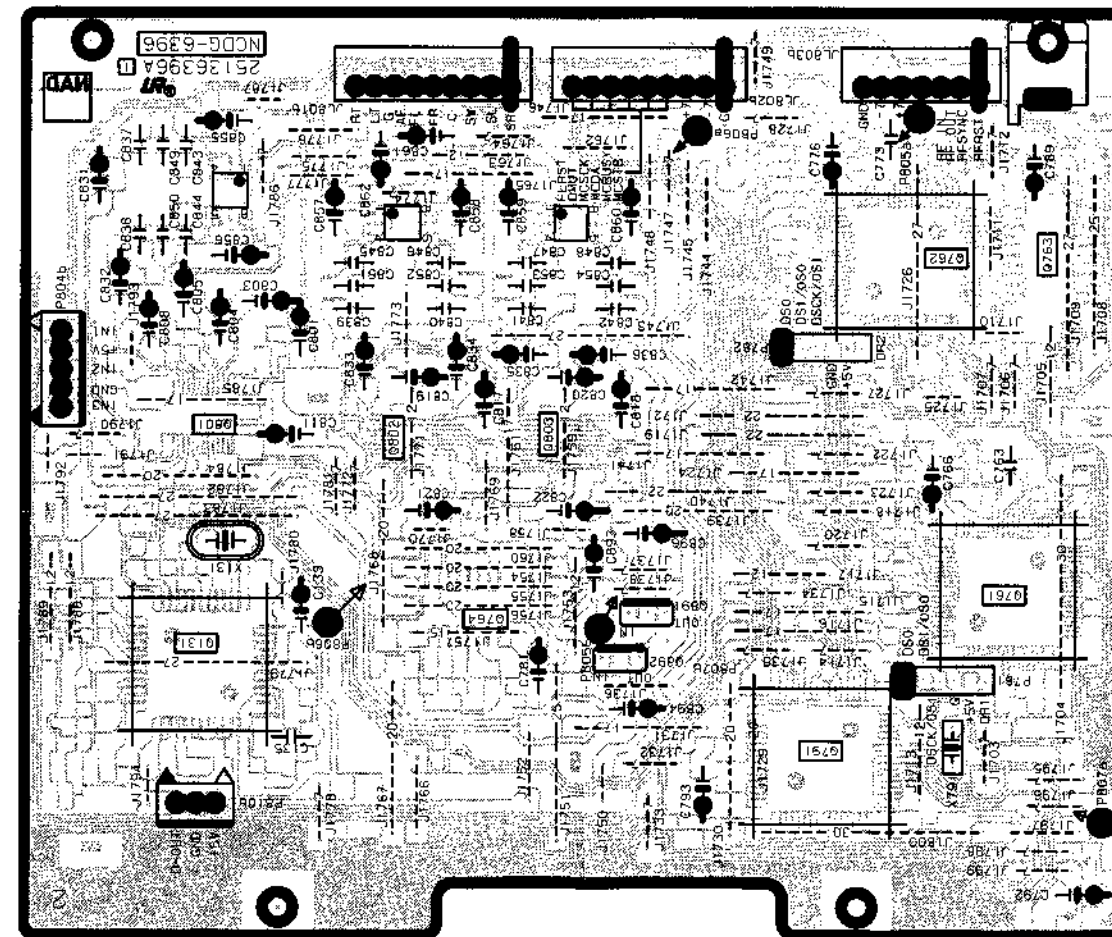







PCB-15 : NADIS-6386 Display circuit PC board

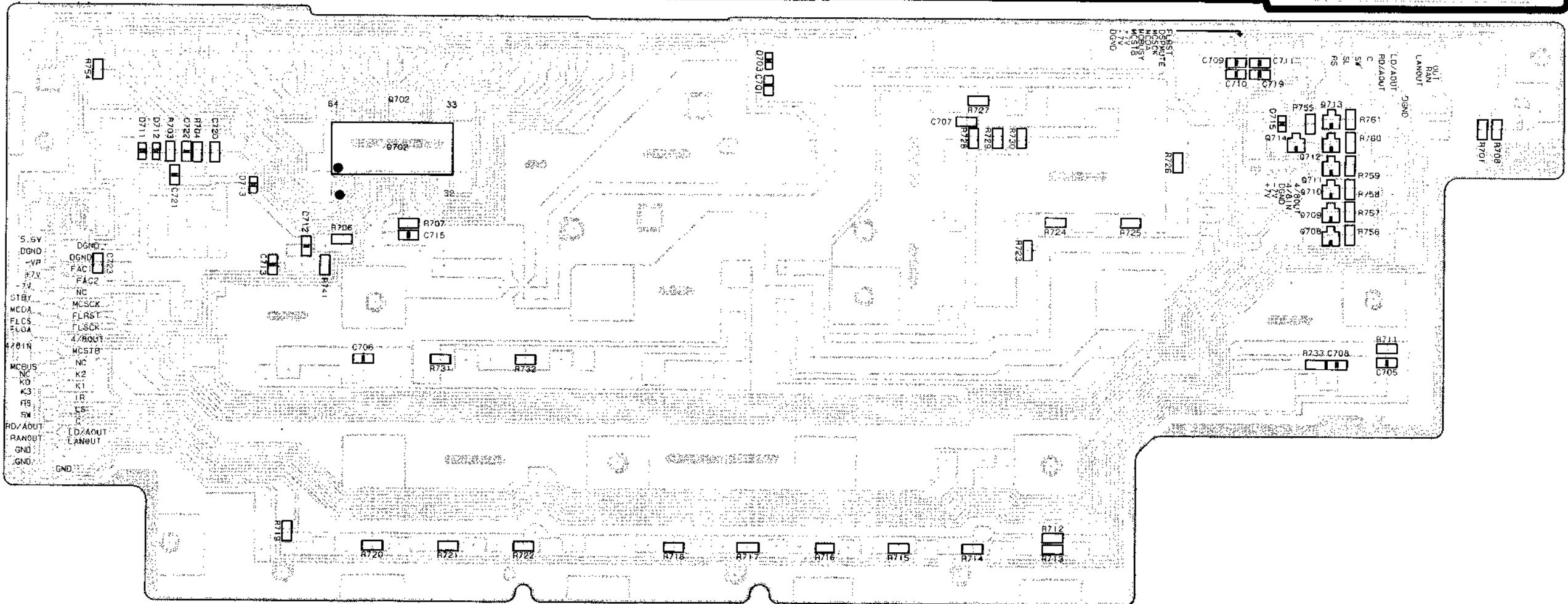
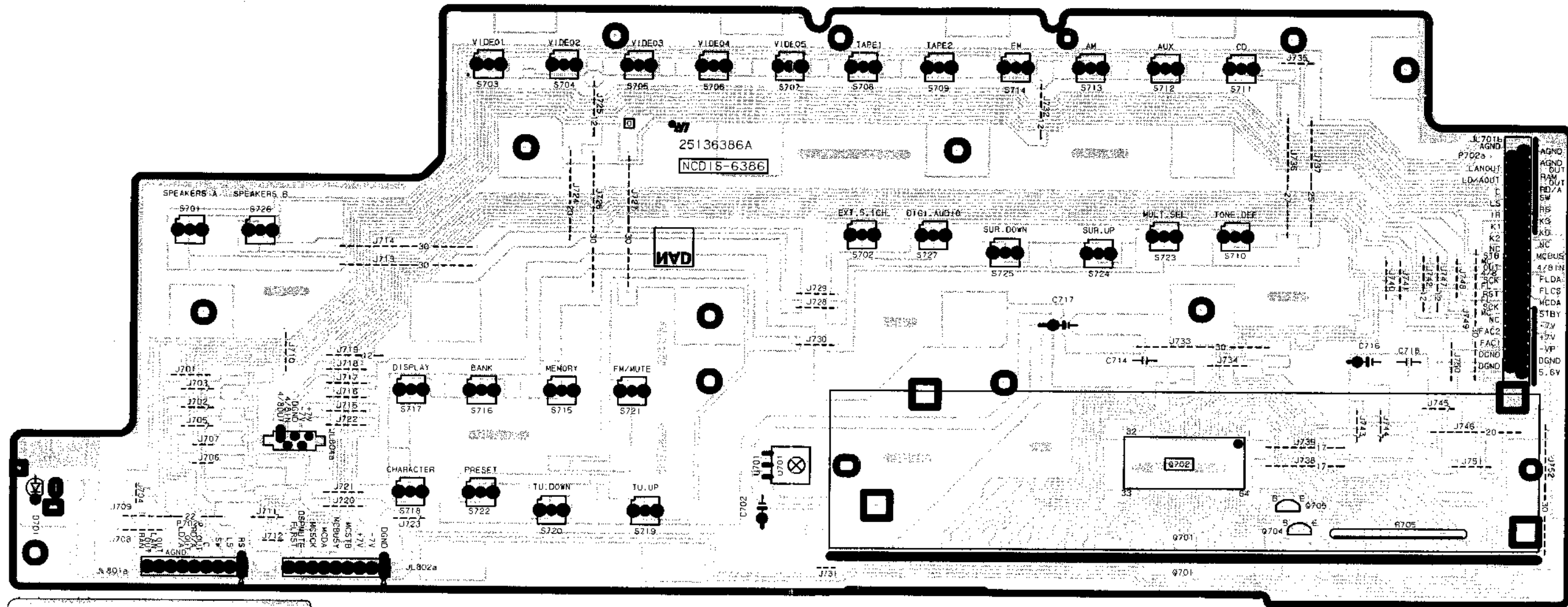



**SCHEMATIC DIAGRAM**

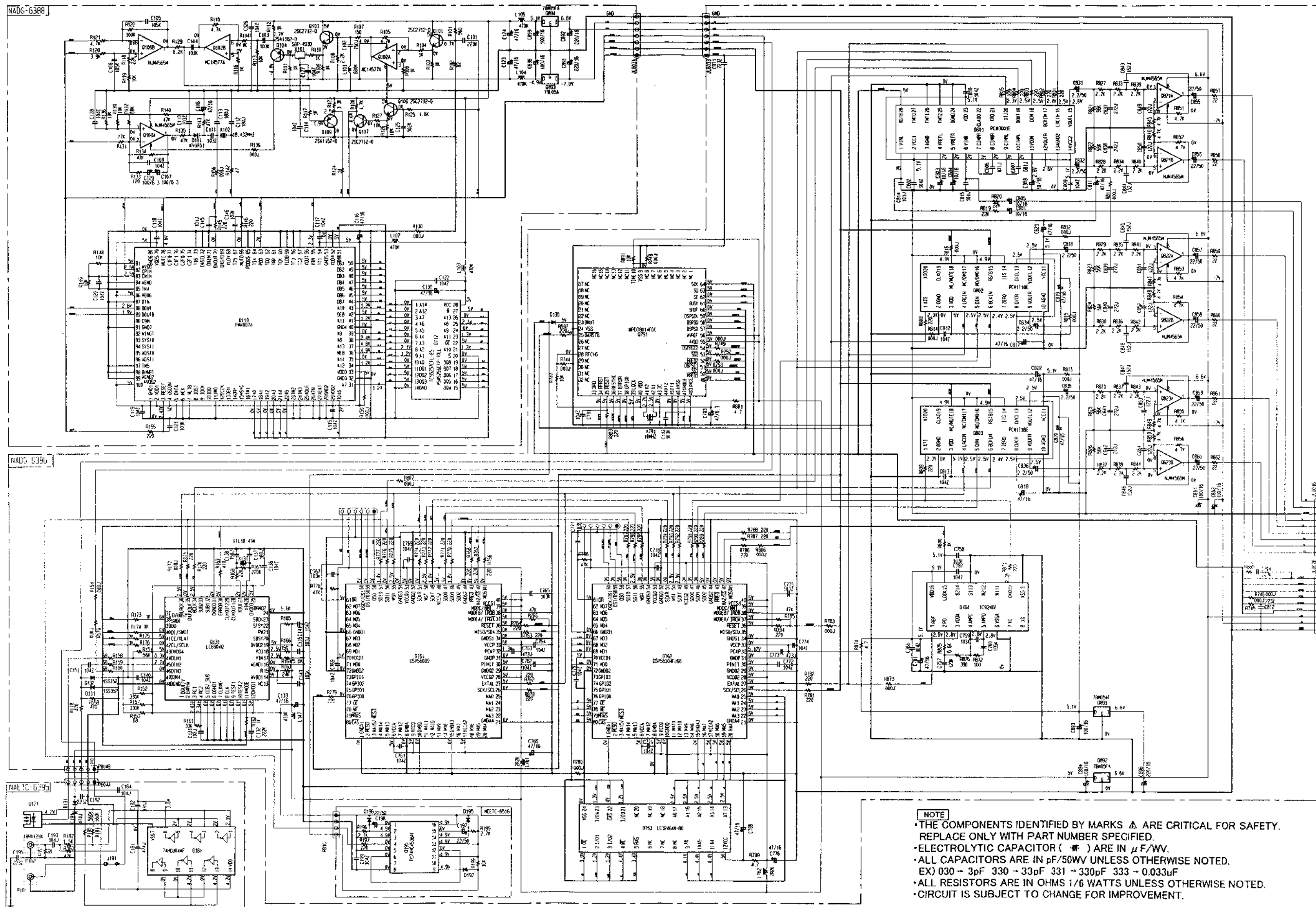

**NOTE**

- THE COMPONENTS IDENTIFIED BY MARKS  $\Delta$  ARE CRITICAL FOR SAFETY. REPLACE ONLY WITH PART NUMBER SPECIFIED.
- ELECTROLYTIC CAPACITOR (  $\ast$  ) ARE IN  $\mu$ F/WV.
- ALL CAPACITORS ARE IN pF/50WV UNLESS OTHERWISE NOTED. EX) 030 - 3pF 330 - 33pF 331 - 330pF 333 - 0.033 $\mu$ F
- ALL RESISTORS ARE IN OHMS 1/8 WATTS UNLESS OTHERWISE NOTED.
- CIRCUIT IS SUBJECT TO CHANGE FOR IMPROVEMENT.

# SCHEMATIC DIAGRAM

**NOTE**  
 • THE COMPONENTS IDENTIFIED BY MARKS  $\Delta$  ARE CRITICAL FOR SAFETY. REPLACE ONLY WITH PART NUMBER SPECIFIED.  
 • ELECTROLYTIC CAPACITOR (  $\ast$  ) ARE IN  $\mu$ F/WV.  
 • ALL CAPACITORS ARE IN pF/50WV UNLESS OTHERWISE NOTED.  
 EX) 030 - 3pF 330 - 33pF 331 - 330pF 333 - 0.033 $\mu$ F  
 • ALL RESISTORS ARE IN OHMS 1/6 WATTS UNLESS OTHERWISE NOTED.  
 • CIRCUIT IS SUBJECT TO CHANGE FOR IMPROVEMENT.

1

2

3

4

5

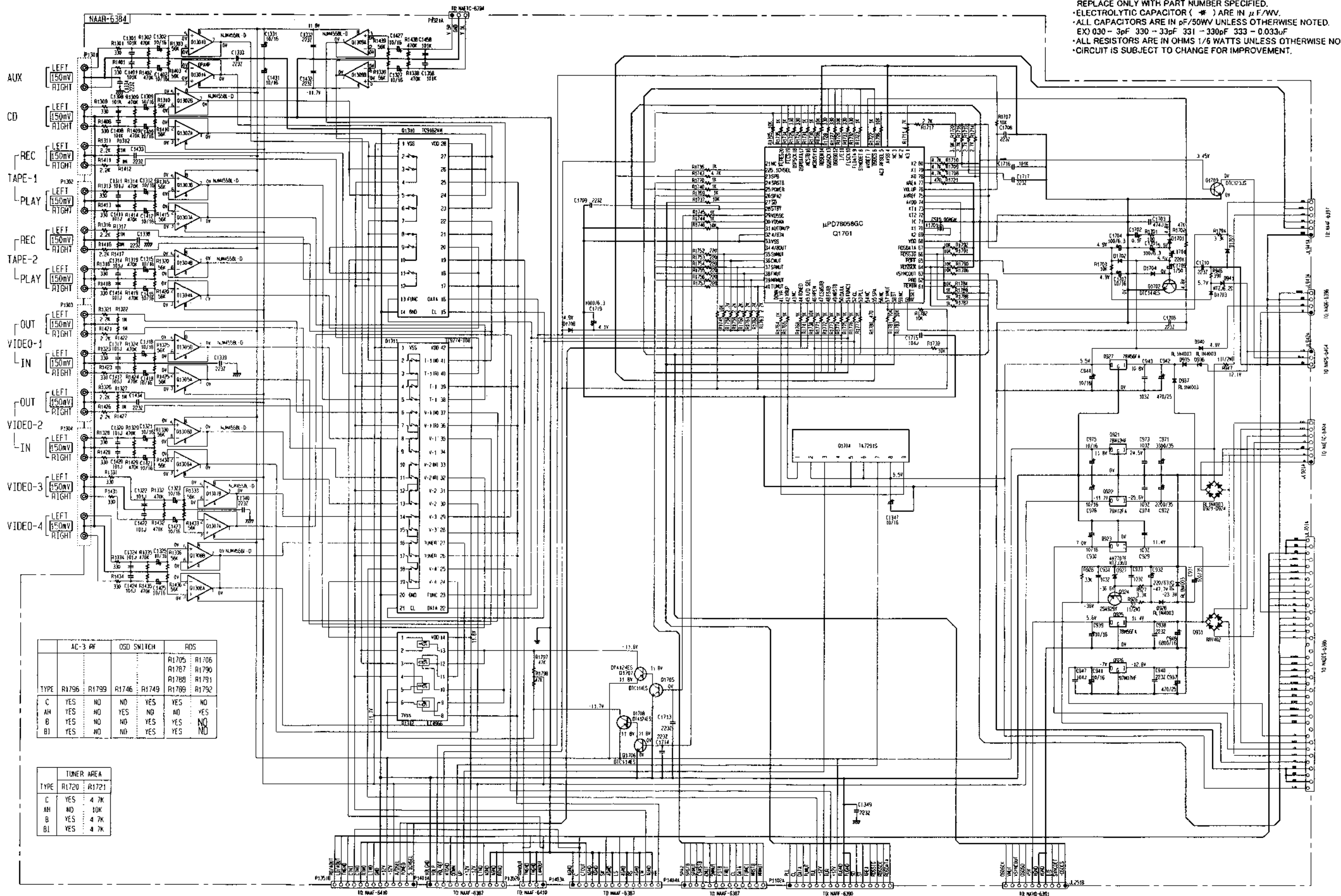

	AC-3 RF		OSD SWITCH		ADS	
TYPE	R1796	R1799	R1746	R1749	R1705	R1706
C	YES	NO	NO	YES	YES	NO
AH	YES	NO	YES	NO	NO	YES
B	YES	NO	NO	YES	YES	NO
BI	YES	NO	NO	YES	YES	NO

	TUNER AREA	
TYPE	R1720	R1721
C	YES	4 7K
AH	NO	10K
B	YES	4 7K
BI	YES	4 7K

**A B C D E F G**

**SCHEMATIC DIAGRAM**

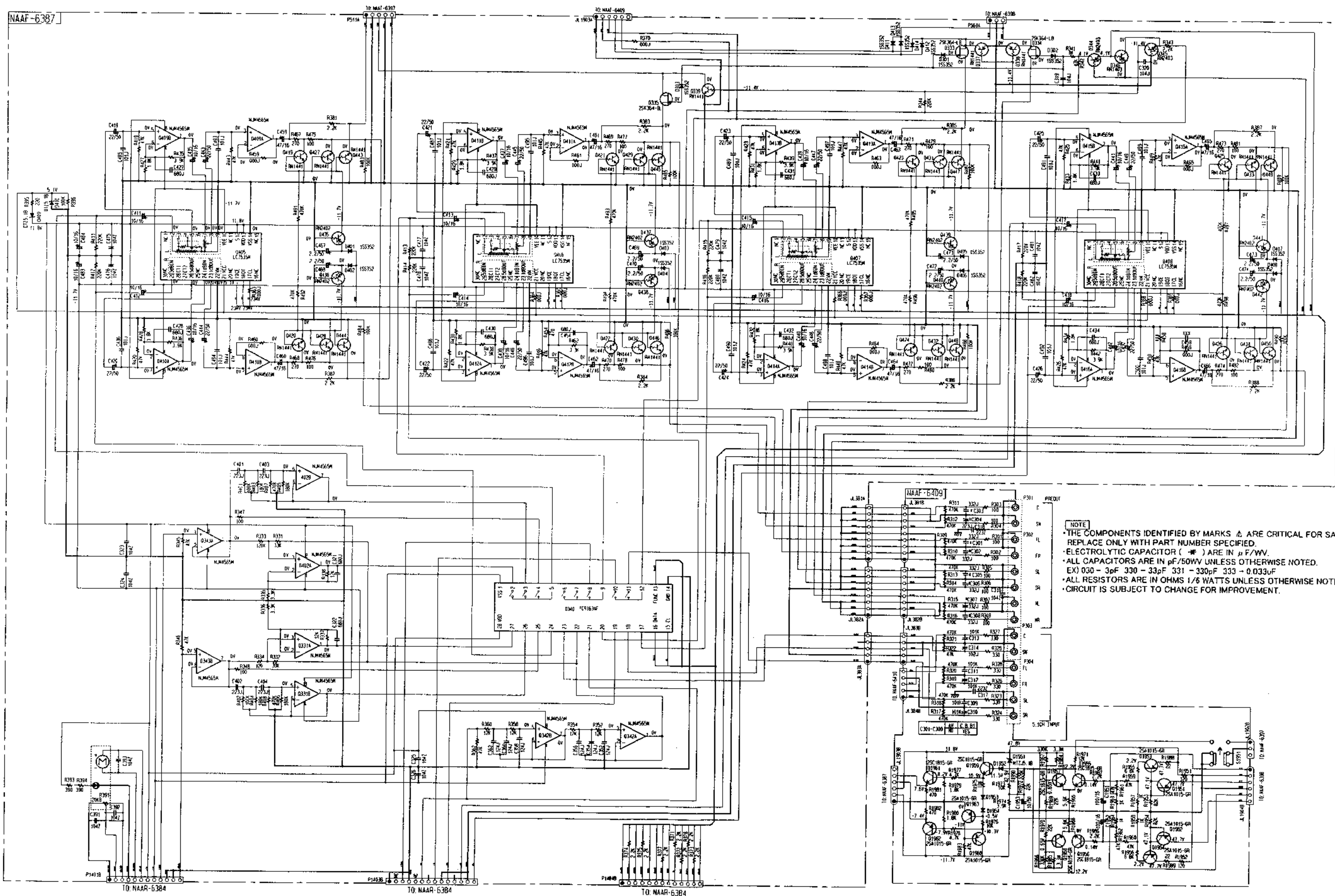

**NOTE**

- THE COMPONENTS IDENTIFIED BY MARKS  $\Delta$  ARE CRITICAL FOR SAFETY. REPLACE ONLY WITH PART NUMBER SPECIFIED.
- ELECTROLYTIC CAPACITOR (  $\text{E}$  ) ARE IN  $\mu\text{F}/\text{V.V.}$
- ALL CAPACITORS ARE IN  $\mu\text{F}/50\text{WV}$  UNLESS OTHERWISE NOTED.  
EX) 030 - 3pF 330 - 33pF 331 - 330pF 333 - 0.033 $\mu\text{F}$
- ALL RESISTORS ARE IN OHMS 1/8 WATTS UNLESS OTHERWISE NOTED.
- CIRCUIT IS SUBJECT TO CHANGE FOR IMPROVEMENT.



# SCHEMATIC DIAGRAM

1  
2  
3  
4  
5

A                      B                      C                      D                      E                      F                      G

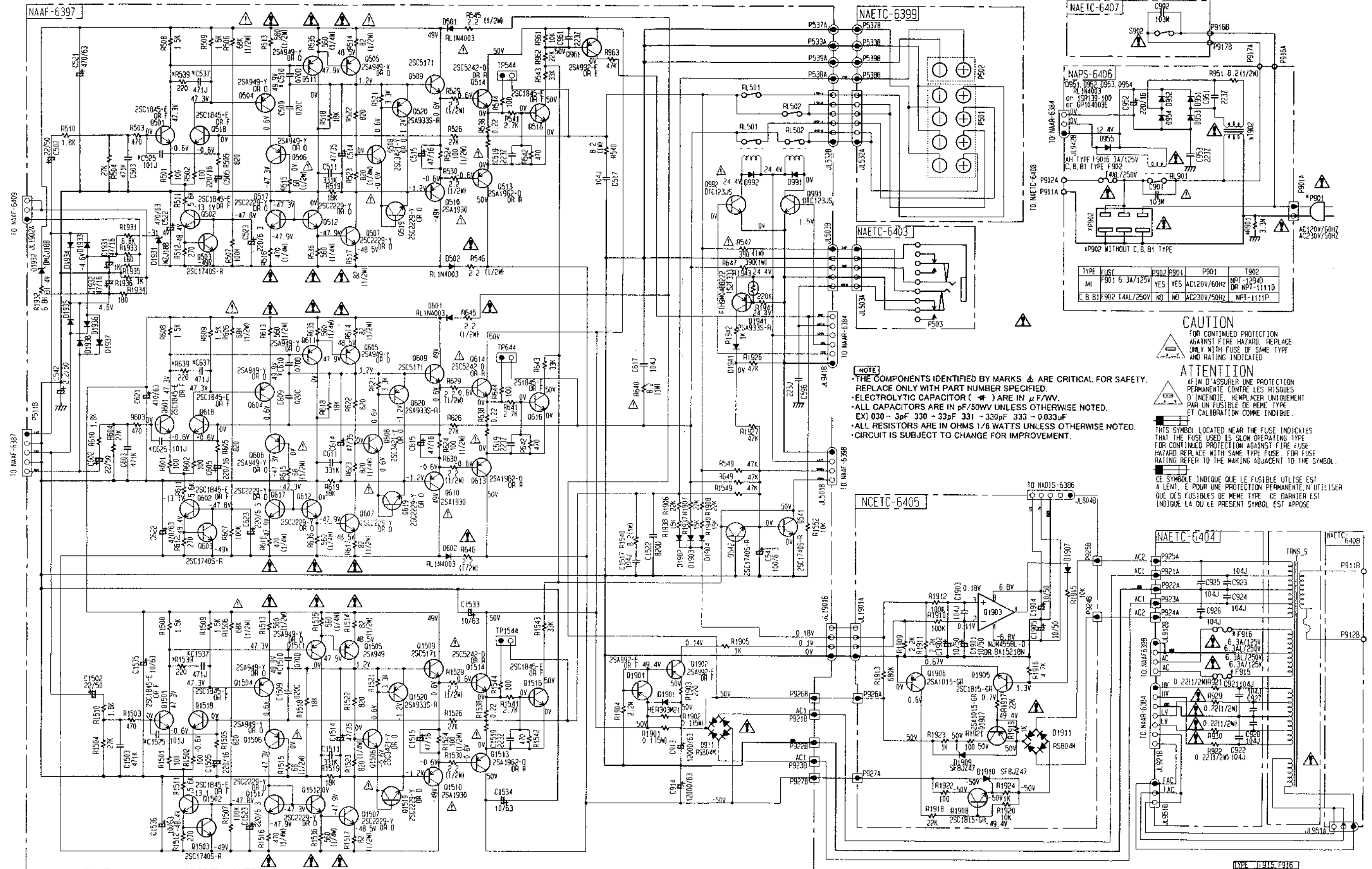

**NOTE**

- THE COMPONENTS IDENTIFIED BY MARKS  $\Delta$  ARE CRITICAL FOR SAFETY. REPLACE ONLY WITH PART NUMBER SPECIFIED.
- ELECTROLYTIC CAPACITOR (  $\ast$  ) ARE IN  $\mu$ F/WV.
- ALL CAPACITORS ARE IN pF/50V UNLESS OTHERWISE NOTED. EX) 030 - 3pF 330 - 33pF 331 - 330pF 333 - 0.033uF
- ALL RESISTORS ARE IN OHMS 1/8 WATT UNLESS OTHERWISE NOTED.
- CIRCUIT IS SUBJECT TO CHANGE FOR IMPROVEMENT.

**CAUTION**

FOR CONTINUED PROTECTION AGAINST FIRE HAZARD, REPLACE ONLY WITH FUSE OF SAME TYPE AND RATING INDICATED.

**ATTENTION**

AFIN D'ASSURER UNE PROTECTION PERMANENTE CONTRE LES RISQUES D'INCENDIE, REMPLACER UNIFORMEMENT PAR UN FUSIBLE DE MEME TYPE ET CALIBRATION COMME INDICIE.

THIS SYMBOL LOCATED NEAR THE FUSE INDICATES THAT THE FUSE USED IS SLOW OPERATING TYPE FOR CONTINUED PROTECTION AGAINST FIRE HAZARD. REPLACE WITH SAME TYPE FUSE. FOR FUSE RATING REFER TO THE MAKING ADJACENT TO THE SYMBOL.

CE SYMBOLE INDIQUE QUE LE FUSIBLE UTILISE EST A LENT. E POUR UNE PROTECTION PERMANENTE, N'UTILISEZ QUE DES FUSIBLES DE MEME TYPE. CE DERNIER EST INDIQUE LA OU LE PRESENT SYMBOLE EST APPOSE.

TYPE	C510, C510, C1510	C525, C625	C1525	C537, C637, C1537	R539, R639, R1539
AH	YES	NO	NO	NO	MI
C, B, B1	NO	YES	YES	YES	YES

TYPE	F915, F916
AH	B, 3A/125V
C, B, B1	3A/125V

# SCHEMATIC DIAGRAM

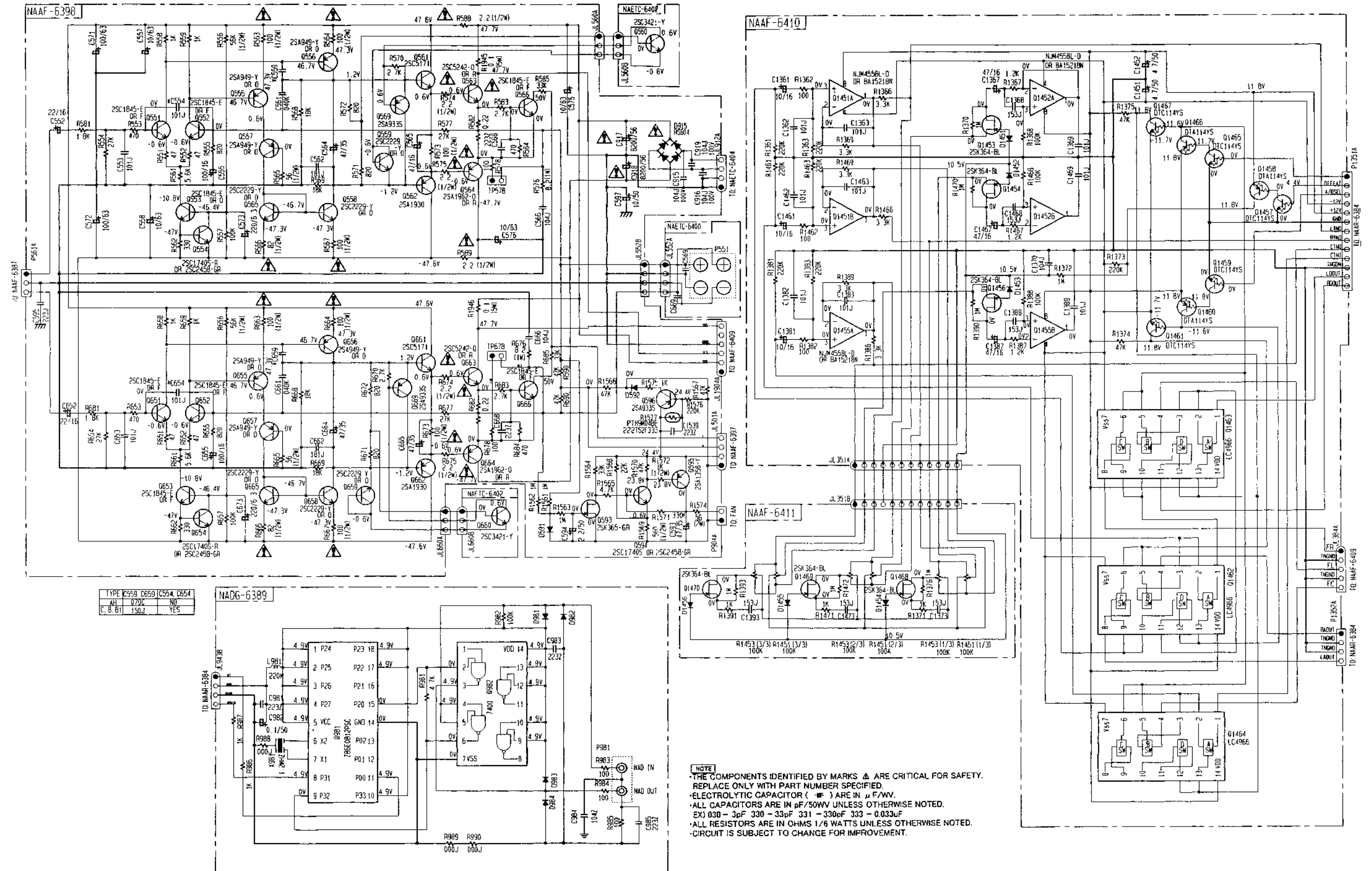



**SCHEMATIC DIAGRAM**

1

2

3

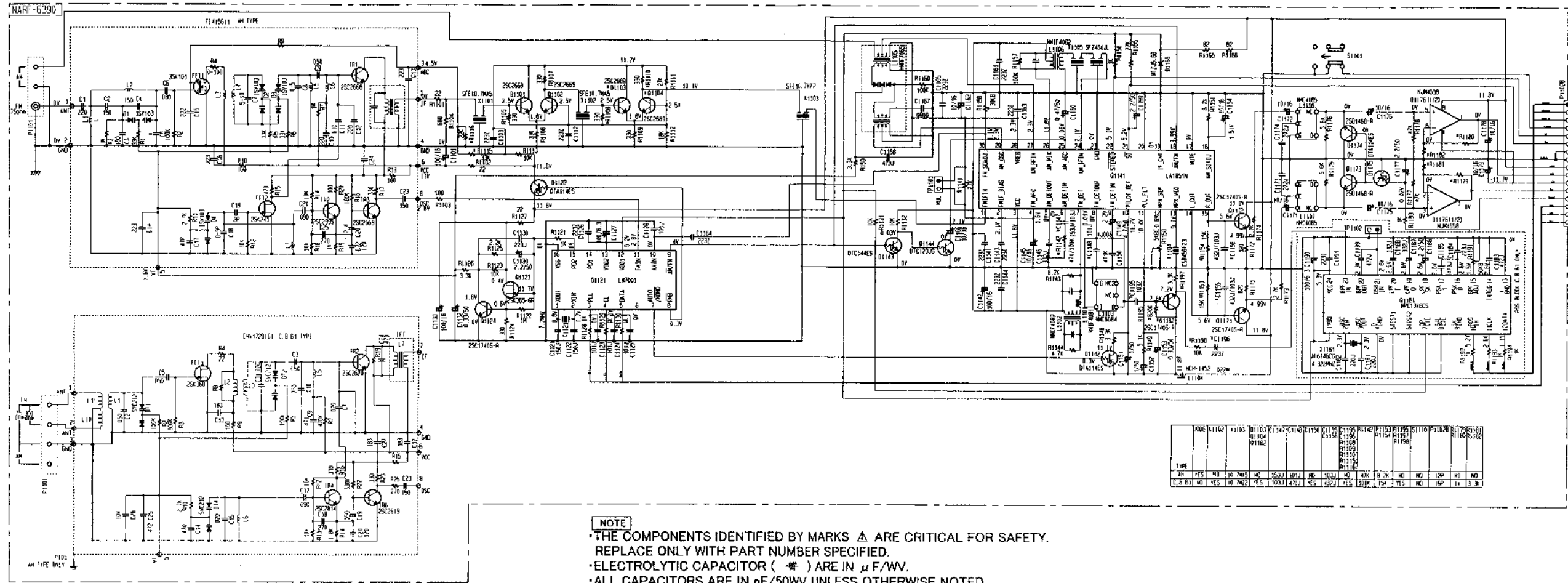

4

5

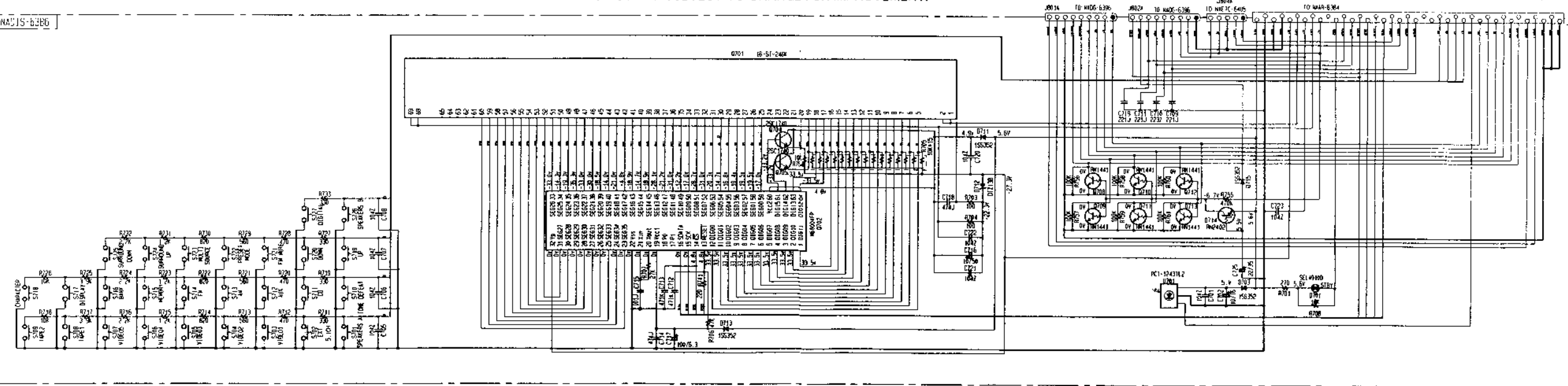

# MAIN MICROPROCESSOR CONNECTION DIAGRAM

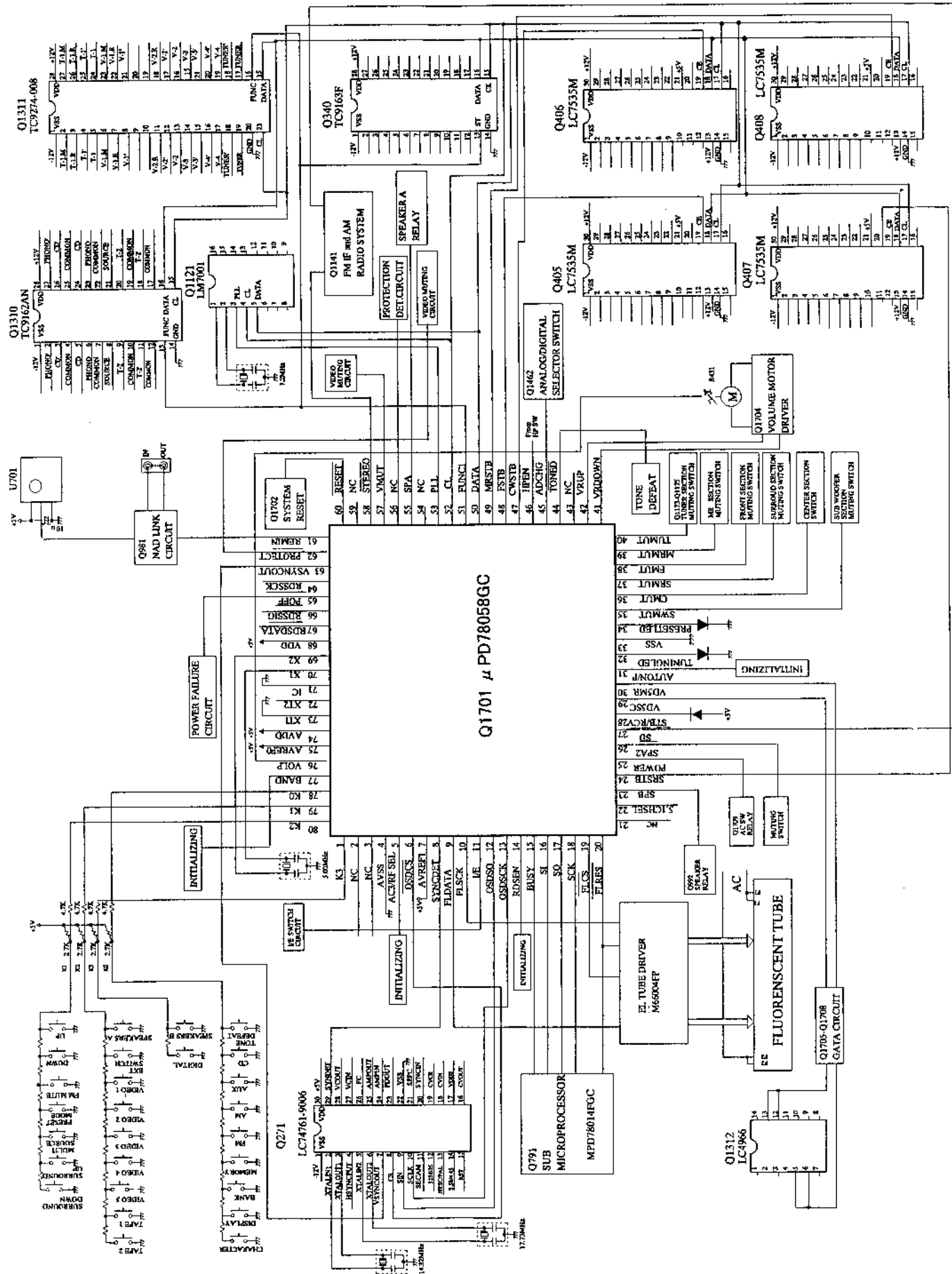

# Main Microprocessor pin Description

No.	Mark	Symbol	Description	
1	P15/ANI5	K3	Operation key connection pin	
2	P16/ANI6	NC		
3	P17/ANI7	NC		
4	AVSS	AVSS	Ground voltage pin for A/D converter	
5	P130/ANO0	AC3/RF SEL	Initializing pin of AC3 RF function	
6	P131/ANO1	OSDCS	Output pin to connect to the terminal CS for OSD controller LC7461	
7	AVREF	AVREF1	Reference voltage pin for D/A converter	
8	P70/SI2/RxD	SYNCDDET	Judge input pin external synchronizing of OSD IC. External synchronizing when high level	
9	P71/SO2/TxD	FLDATA	Data output pin to connect to pin SDTAT of FL tube driver IC	
10	P72/SCK2/ASCK	FLSCK	Clock output pin to connect to pin SCK of FL tube driver IC	
11	P20/SI1	I/E	Output pin to show the status of synchronizing for OSD IC. High level when external synchronizing.	
12	P21/SO1	OSDSO	Output pin to connect to the pin SIN of OSD controller.	
13	P22/SCK1	OSDSCK	Output pin to connect to the pin SCLK of OSD controller.	
14	P23/STB	ROSEN	Initializing input for RDS	
15	P24/BUSY	BUSY	Busy pin for transfer to the sub microprocessor	
16	P25/SI0/SB0	SI	Data input pin for transfer to the sub microprocessor	
17	P26/SO0/SB1	SO	Data output pin for transfer to the sub microprocessor	
18	P27/SCK0	SCK	Clock output pin for transfer to the sub microprocessor	
19	P40/AD0	FLCS	Output pin to connect to pin CS of FL tube driver.	
20	P41/AD1	FLRES	Output pin to connect to pin RES of FL tube driver. Use for the reset signal of sub microprocessor when power on.	
21	P42/AD2	NC	Not used	
22	P43/AD3	5.1CHSEL	Multi room indicator and control output pin	
23	P44/AD4	SPB	Speaker B relay control output pin	
24	P45/AD5	SRSTB	Strobe output pin to connect to the pin STB of Electro. volume	
25	P46/AD6	POWER	Power source control pin	
26	P47/AD7	SPA2	Muting output pin when SPEAKER switch is changed A.	
27	P50/A8	SD	Station detection pin	
28	P51/A9	STBY/REC V	RECEIVED or STANDBY indicator control output pin	
29	P52/A10	VIDEO5	Control output pin for VIDEO-5 on the front panel. On when high level.	
30	P53/A11	VIDEO5'	Control output pin for multi-source and recording of VIDEO-5 on the front panel.	
31	P54/A12	AUTON/P	Initializing pin to select NTSC or PAL.	
32	P55/A13	4/8 IN	4/8 ohm input pin.	
33	VSS	VSS	Ground pin	
34	P56/A14	4/8 OUT	4/8 ohm output pin.	
35	P57/A15	WMUT	Muting control output pin for sub-woofer. On when high level	
36	P60	CMUT	Muting control output pin for center amplifier. On when high level	
37	P61	SRMUT	Muting control output pin for surround amplifier. On when high level	
38	P62	FMUT	Muting control output pin for front amplifier. On when high level	
39	P63	MRMUT	Muting control output pin for multi-amplifier. On when high level	
40	P64/RD	TUMUT	Muting control output pin for tuner section. On when high level!	
41	P65/WR	VOLDOWN	Volume control output pin	
42	P66/WAIT	VOLUP	Volume control output pin	
These pins change as the below table by the signal from remote control transmitter.				
		Operation	Vol up	Vol down
		Stop	H	H
		When up	H	L
		When down	L	H
		Power off	L	L
43	P67/ASTB	NC	Not used	
44	P30/TO0	TONED	Tone defeat select pin	
45	P31/TO1	ADCHG	Analogue/digital selector switch pin	
46	P32/TO2	HPEN	Detection input pin for insertion of headphone. When the headphone is used. The surround mode turns off.	
47	P33/TI1	CWSTB	Strobe output pin to connect to the terminal STB of Electro volume.	
48	P34/TI2	FSTB	Strobe output pin to connect to the terminal STB of Electro volume.	
49	P35/PCL	MRSTB	Strobe output pin to connect to the terminal STB of Electro volume.	
50	P36/BUZ	DATA	Data output pin to the PLL and Electro volume ICs.	
51	P37	FUNC1	Strobe output pin to the function switch ICs.	
52	P120/RTP0	CL	Strobe output pin to the function switch, PLL and Electro volume ICs.	
53	P121/RTP1	PLL	Chip enable output pin to PLL IC.	
54	P122/RTP2	NC	Not used	
55	P123/RTP3	SPA	Control output pin for speaker relay A. On when high level.	
56	P124/RTP4	NC	Not used	
57	P125/RTP5	VMUT	Muting control output for video signal	
58	P126/RTP6	STEREO	Input pin to detect the stereo broadcast. Low level when stereo broadcast.	
59	P127/RTP7	NC	Not used	
60	RESET	RESET	System reset input pin.	
61	P00/INTP0/TI00	REMIN	Remote control signal input pin	
62	P01/INTP1	PROTECT	Detection input pin for protection circuit.	
63	P02/INTP2	VSYNCOOUT	Vertical synchronizing signal input pin	
64	P03/INTP3	RDSSCK	Clock input pin from RDS decoder.	
65	P04/INTP4	POFF	Detection input pin for power failure.	
66	P05/INTP5	RDSSIG	Detection input pin for RDS broadcast.	
67	P06/INTP6	RDSDATA	Data input pin from RDS decoder.	
68	VDD	VDD	Power supply pin	
69	X2	X2	Crystal connection pins for main system clock	
70	X1	X1	These pins is connected to the 5MHz ceramic oscillator.	
71	IC	IC	Internal connection pin.	
72	XT2	XT2	Crystal connection pins for sub system clock	
73	XT1/P07	XT1	Not used.	
74	AVDD	AVDD	Analog power supply pin for A/D converter.	
75	AVREF0	AVREF0	Reference voltage input pin for A/D converter.	
76	P10/ANI0	VOLP	Input pin to detect the position of master volume.	
77	P11/ANI1	BAND	Initializing input pin for band area	
78	P12/ANI2	K0	Operation key connection pin	
79	P13/ANI3	K1	Operation key connection pin	
80	P14/ANI4	K2	Operation key connection pin	



# SUB MICROPROCESSOR CONNECTION DIAGRAM

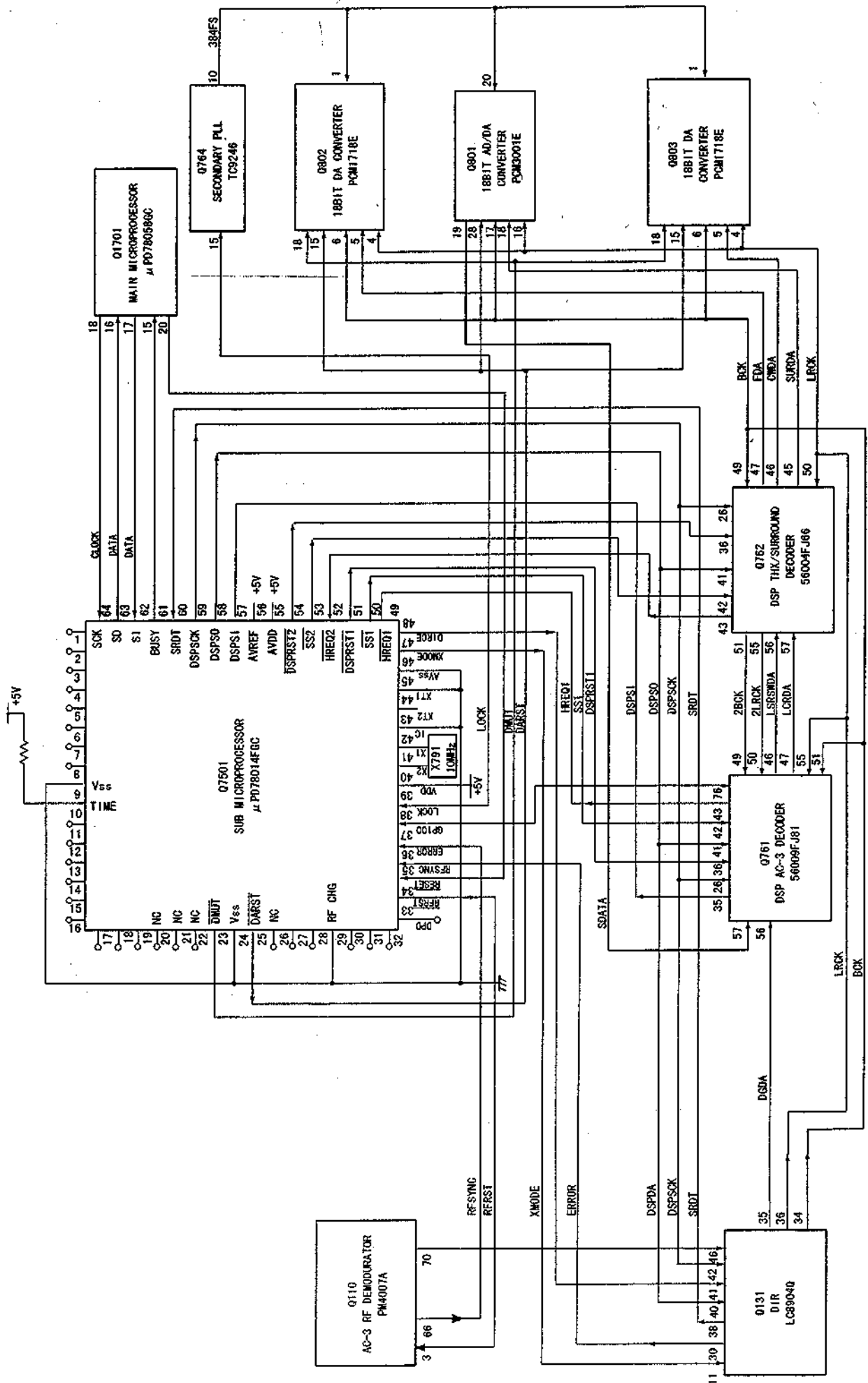

## SUB MICROPROCESSOR PIN DESCRIPTION

Pin No.	Terminal	Description
1-8	NC	
9	VSS	Ground terminal.
10	TIME	Not used.
11-22	NC	
23	DMUT	Muting output terminal for digital section.
24	VSS	Ground terminal.
25	DARSTB	Output terminal to connect to the terminal RSTB of D/A converter PCM1718E..
26	NC	
27	AC-3LED	"AC-3" indicator control output terminal.
28	RF CHG	Initializing input.
29-32	NC	
33	DPD	Digital power down control output terminal.
34	RF RST	Reset output terminal for AC-3 RF demodulator.
35	RESRT	System reset input terminal.
36	RFSYNC	Synchronizing detection input pin for AC-3 RF demodulator.
37	ERROR	Input terminal to connect to terminal ERROR of DIR IC LC8904Q.
38	GPI00	Input terminal to connect to terminal GPI00 of DST IC.
39	LOCK	Input terminal to connect to the terminal LOCK of clock generation IC TC9246F.
40	VDD	Power supply (5V).
41	X2	Crystal resonator connection terminals for main system.
42	X1	Connect the ceramic resonator 10MHz.
43	IC	Internal connection terminal.
44	XT2	Sub system clock connection terminals.
45	XT1	Not used.
46	AVSS	Ground terminal for A/D converter.
47	XMODE	Output terminal to connect to the terminal XMODE of DIR IC LC8904Q.
48	DIRCE	Chip enable output terminal to connect to the terminal CE of DIR IC LC8904Q.
49	HREQ1	Input terminal to connect to the terminal HREQ of DSP IC DSP56009.
50	SS1	Input terminal to connect to the terminal SS of DSP IC DSP56009.
51	DSPRST1	Input terminal to connect to the terminal RESET of DSP IC DSP56009.
52	HREQ2	Input terminal to connect to the terminal HREQ of DSP IC DSP56004.
53	SS2	Input terminal to connect to the terminal SS of DSP IC DSP56004.
54	DSPRST2	Input terminal to connect to the terminal RESET of DSP IC DSP56004.
55	AVDD	Power supply circuit for analog section.
56	AVREF	Reference voltage input terminal for A/D converter.
57	DSPSI	Input terminal to connect to the terminal MOSI of DSP IC DSP56009.
58	DSPSO	Data output terminal. Connect to the terminal MOSI of DSP ICs and the terminal DI of DIR IC.
59	DSPSCK	Clock output terminal. Connect to the terminal SCK of DSP ICs and the terminal CL of DIR IC.
60	SRDT	Input terminal to connect to the terminal SRDT of DIR IC.
61	BUSY	Busy signal output terminal to main microprocessor.
62	SI	Data input terminal from main microprocessor.
63	SO	Data output terminal from main microprocessor.
64	SCK	Clock input terminal from main microprocessor.

# IC BLOCK DIAGRAMS AND PIN DESCRIPTIONS

## TC9162AN (Analog Switch)

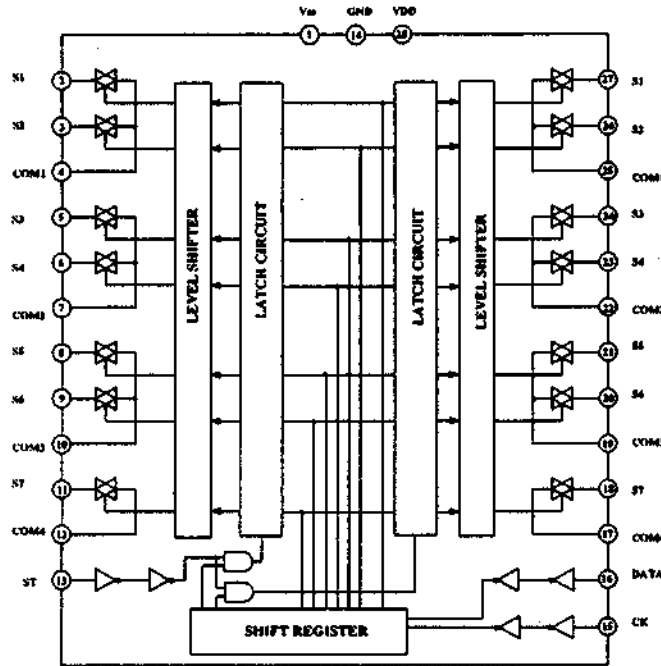

Pin No.	Symbol	Function
1	Vss	Power supply pin (-)
14	GND	Ground pin
28	VDD	Power supply pin (+)
2,3,5,6,8,9,11	S1 ~ S7	Switch input/output pins
27,26,24,23,21,20,18	S1 ~ S7	Switch input/output pins
4,7,10,12	COM1 ~ COM4	Common pins
25,22,19,17	COM1 ~ COM4	Common pins
13	ST	Strobe input pin for data interruption
15	CK	Clock input for data transfer
16	DATA	Serial data input pin for switch setting

## TC9274N-008 (Analog Switch)

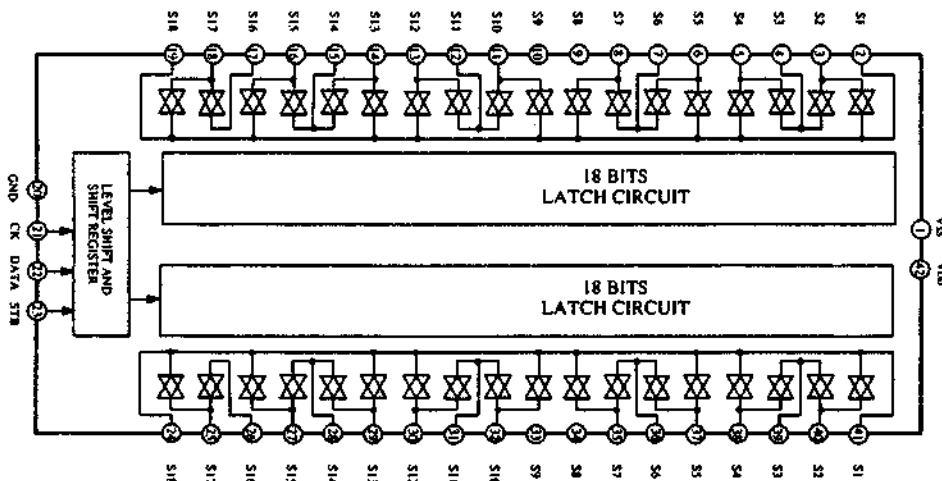

# TC9163AN (Analog Switch)

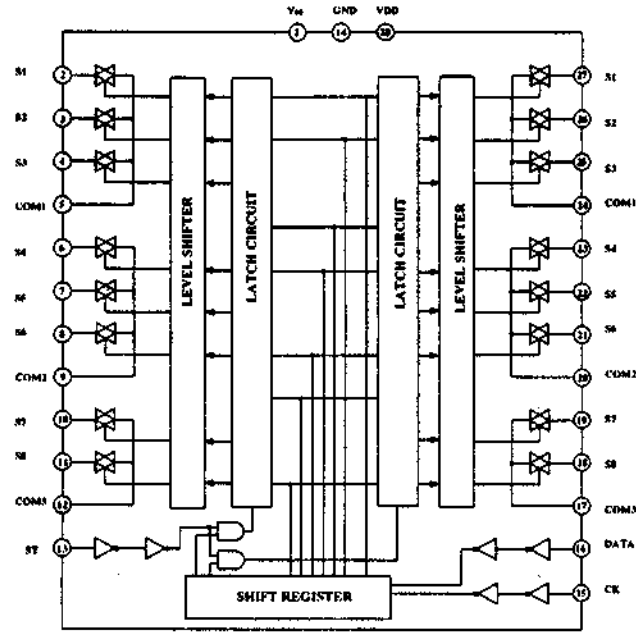

Pin No.	Symbol	Function
1	Vss	Power supply pin (-)
14	GND	Ground pin
28	VDD	Power supply pin (+)
2,3,4,6,7,8,10,11	S1 ~ S8	Switch input/output pins
27,26,25,24,22,21,19,18	S1 ~ S8	Switch input/output pins
5,9,12	COM1 ~ COM3	Common pins
24,20,17	COM1 ~ COM3	Common pins
13	ST	Strobe input pin for data interruption
15	CK	Clock input for data transfer
16	DATA	Serial data input pin for switch setting

# TC7291 (Volume Motor Driver)

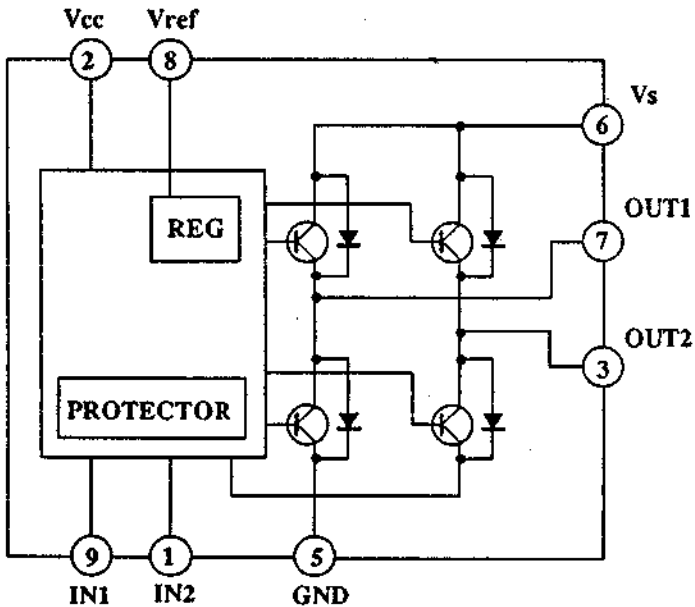

INPUT		OUTPUT		MODE
IN1	IN2	OUT1	OUT2	
0	0	∞	∞	STOP
1	0	H	L	CW/CCW
0	1	L	H	CCW/CW
1	1	L	L	BRAKE

CCW:Counter-clockwise direction  
CW:Clockwise direction



### TC9217F (Electro volume)

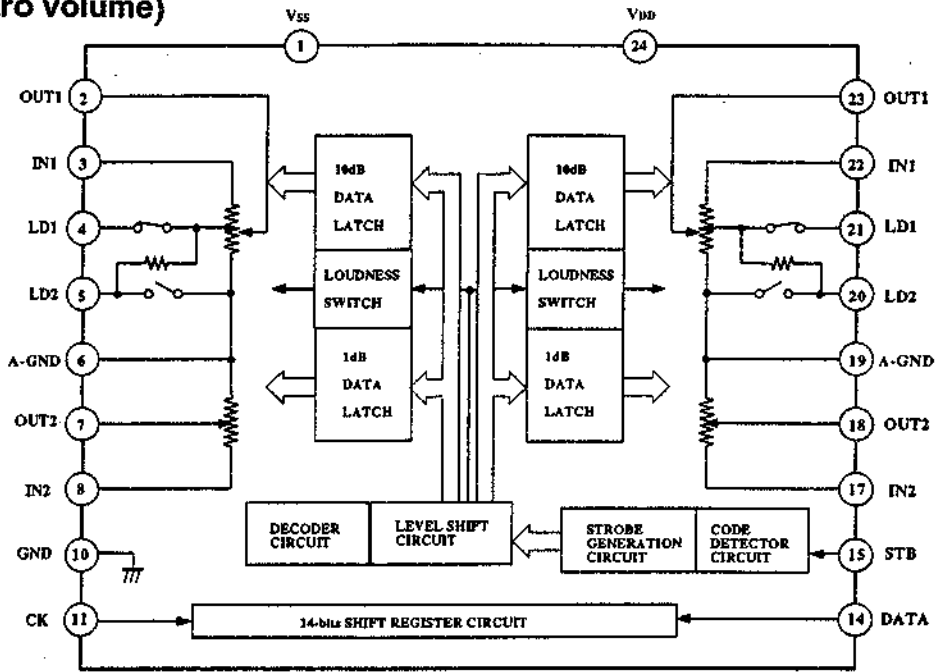

### LC4966 (Video selector switch)

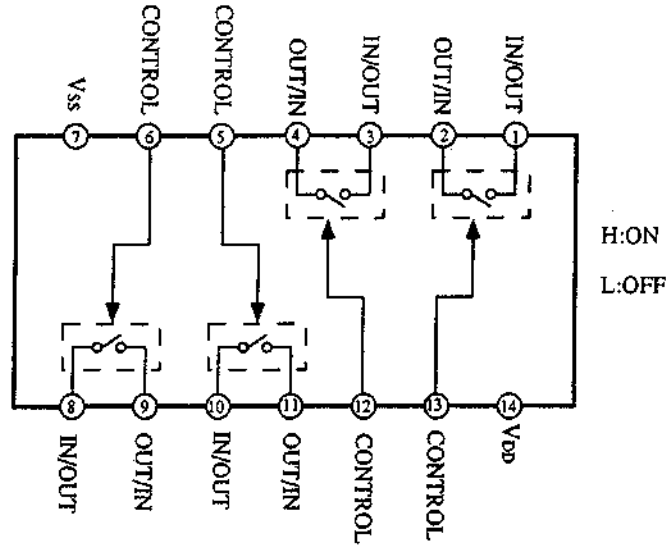

### BA7625 (Video Selector Switch)

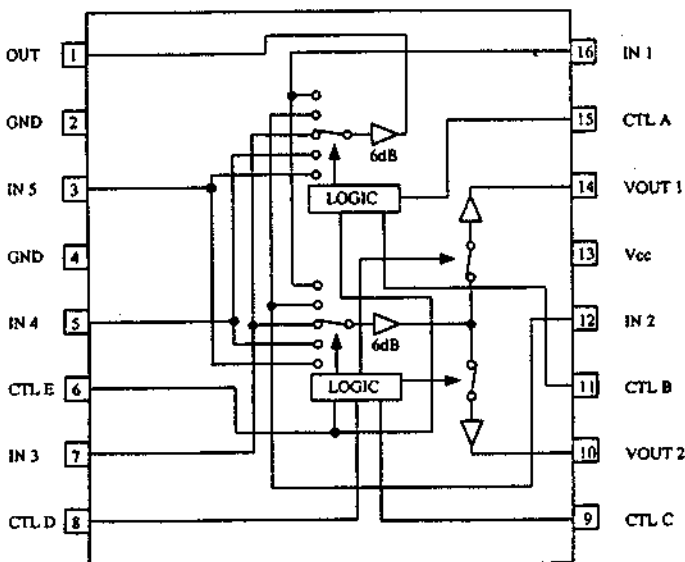

#15	#11	#6	#1
A	B	E	MONITOR OUT
L	L	X	IN1
H	L	X	IN2
L	H	X	IN3
H	H	L	IN4
H	H	H	IN5

X: Don't care

#9	#8	#6	#14
C	D	E	VOUT1
L	L	X	IN1
H	L	X	IN2
L	H	X	IN3
H	H	L	IN4
H	H	H	IN5

#15	#11	#6	#10
A	B	E	VOUT 2
L	L	X	IN1
H	L	X	IN2
L	H	X	IN3
H	H	L	IN4
H	H	H	IN5

LC8904 (DIR)

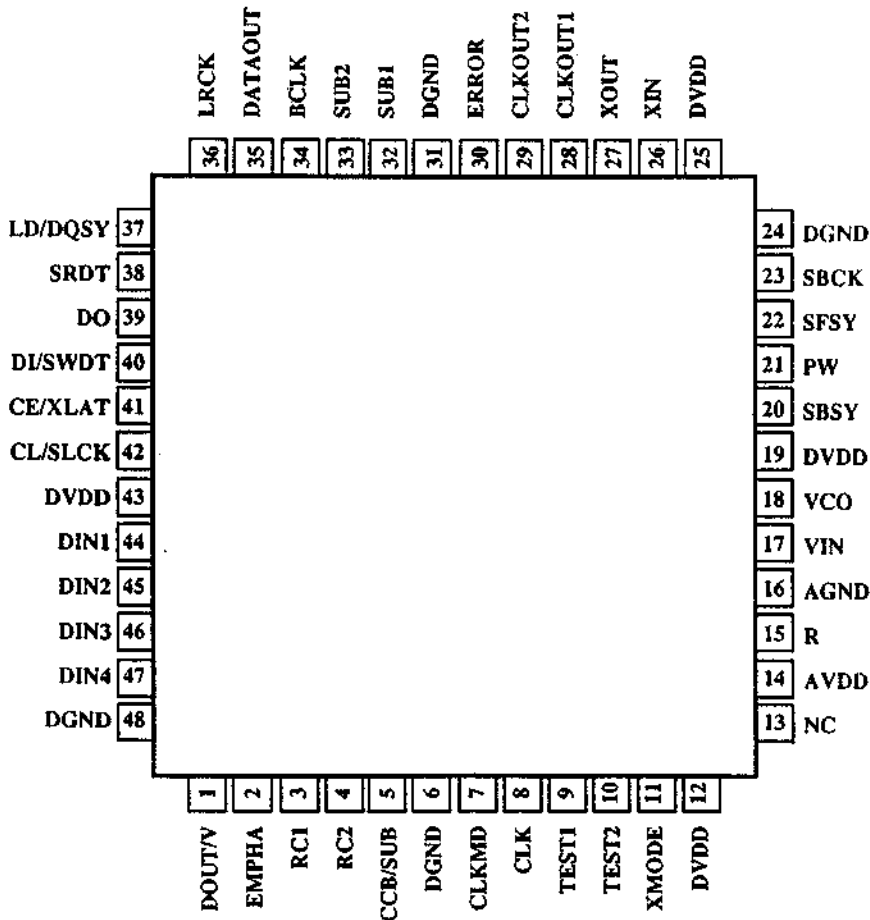

Pin No.	Terminal	I/O	Description
1	DOUTV	O	EIAJ data and parity flag output pin
2	EMPHA	O	Emphasis monitor output pin
3	RC1	I	Input pin for CR oscillator
4	RC2	O	Output pin for CR oscillator
5	CCB/SUB	I	Input pin for interface selector of microprocessor
6	DGND		Digital ground pin
7	CLKMD	I	Changeover input pin for clock signal
8	CLK	I	Changeover input pin for clock signal
9	TEST1	I	Test pin
10	TEST2	I	Test pin
11	XMODE	I	Reset input pin
12	DVDD		Digital power supply pin
13	NC		
14	AVDD		Analog power supply pin
15	R	I	Input pin for range adjustment of VCO oscillator
16	AGND		Analog ground pin
17	VIN	I	Input pin for VCO oscillator
18	VCO	O	Output pin of PLL
19	DVDD		Digital ground pin
20	SBSY	O	Block sink output pin for sub code interface
21	PW	O	Data output pin for sub code interface
22	SFSY	O	Frame sink output pin for sub code interface
23	SBCK	I	Shift clock input pin for data read of sub code interface
24	DGND		Digital ground pin
25	DVDD		Digital power supply pin
26	XIN	I	Input pin for crystal oscillator
27	XOUT	O	Output pin for crystal oscillator
28	CLKOUT1	O	Clock output pin for crystal oscillator
29	CLKOUT2	O	Clock output pin for 256fs or 128fs
30	ERROR	O	Error muting output pin
31	DGND		Digital ground pin
32	SUB1	O	Monitor output pin for sampling frequency
33	SUB2	O	Monitor output pin for sampling frequency
34	BCLK	O	Bit clock output pin
35	DATAOUT	O	Audio data output pin
36	LRCK	O	LR clock output pin
37	LD/DQSY	O	Data sink output pin for sub code Q of microprocessor
38	SRDT	O	Data output pin of microprocessor. CCB/SUB=L
39	DO	O	Data output pin of microprocessor. CCB/SUB=H
40	DI/SWDT	I	Data input pin from microprocessor
41	CE/XLAT	I	Chip enable and latch input pin from microprocessor
42	CL/SLCK	I	Clock input pin from microprocessor
43	DVDD		Digital power supply pin
44	DIN1	I	Data input pin
45	DIN2	I	Data input pin
46	DIN3	I	Data input pin
47	DIN4	I	Data input pin
48	DGND		Digital ground pin

# PM4007A (AC-3 RF Demodulator)

Pin No.	Symbol	I/O	Description
1	GND	-	Ground
2	VDD	-	Power supply (+5V)
3	RESET	I	System reset. Reset when "L".
4	OSCEN	I	Oscillation control. Oscillation ON when "H".
5	DATA	I	For IC testing. Normally connected to ground (or unconnected).
6	WCK	I	For IC testing. Normally connected to ground (or unconnected).
7	MLTB	I	For IC testing. Normally connected to ground (or unconnected).
8	IBST	0	Output for IC testing.
9	IDCK	0	Output for IC testing.
10	ID0	0	Output for IC testing.
11	IM0	I	For IC testing. Normally connected to ground (or unconnected).
12	IBCK	0	Output for IC testing.
13	IDEN	0	Output for IC testing.
14	IDRY	0	Output for IC testing.
15	IMYC	0	Output for IC testing.
16	IM1	0	For IC testing. Normally connected to ground (or unconnected).
17	IA0	0	External RAM address output. Address 0(LSB).
18	IA1	0	External RAM address output. Address 1.
19	IA2	0	External RAM address output. Address 2.
20	IA3	0	External RAM address output. Address 3.
21	IA4	0	External RAM address output. Address 4.
22	IA5	0	External RAM address output. Address 5.
23	IM2	I	For IC testing. Normally connected to ground (or unconnected).
24	IM3	I	For IC testing. Normally connected to ground (or unconnected).
25	XOUT	0	Output for IC testing.
26	XIN	I	For IC testing. Normally connected to ground (or unconnected).
27	XETX	I	For IC testing. Normally connected to ground (or unconnected).
28	GND	-	Ground.
29	VDD	-	Power supply (+5V)
30	AA6	0	External RAM address output. Address 6.
31	AA7	0	External RAM address output. Address 7.
32	GND	-	Ground.
33	VDD	-	Power supply (+5V)
34	AA2	0	External RAM address output. Address 12.
35	AA4	0	External RAM address output. Address 14(MSB).
36	WEB	0	Write-enable signal for external RAM. Active when "L".
37	AA3	0	External RAM address output. Address 13.
38	AA8	0	External RAM address output. Address 8.
39	AA9	0	External RAM address output. Address 9.
40	GND	-	Ground.
41	AA11	0	External RAM address output. Address 11.
42	OEB	0	Output-enable signal for external RAM. Active when "L".
43	AA10	0	External RAM address output. Address 10.
44	DB7	I/O	External RAM data terminal. Data Bus 7.
45	DB6	I/O	External RAM data terminal. Data Bus 6.
46	DB5	I/O	External RAM data terminal. Data Bus 5.
47	DB4	I/O	External RAM data terminal. Data Bus 4.
48	DB3	I/O	External RAM data terminal. Data Bus 3.
49	DB2	I/O	External RAM data terminal. Data Bus 2.
50	DB1	I/O	External RAM data terminal. Data Bus 1.
51	DB0	I/O	External RAM data terminal. Data Bus 0.

Pin No.	Symbol	I/O	Description
52	VDD	-	Power supply (+5V).
53	GND	-	Ground.
54	TI1	I	For IC testing. Normally connected to VDD.
55	VIN	I	V <sub>EXD</sub> output.
56	VOUT	0	For IC testing. Normally connected to ground. (or unconnected.)
57	TI2	I	For IC testing. Normally connected to ground. (or unconnected.)
58	TI3	I	For IC testing. Normally connected to ground. (or unconnected.)
59	TI0B	I	For IC testing. Normally connected to ground. (or unconnected.)
60	ICK	I	For IC testing. Normally connected to ground. (or unconnected.)
61	TRP	0	Output for IC testing.
62	ID0	0	Output for IC testing.
63	PDO	0	Phase comparator output. (3 states)
64	TI4	I	For IC testing. Normally connected to ground. (or unconnected.)
65	PDOIS	I	PDO output control. Output 0M when "L".
66	MUTO	0	Muting output. Muted when "H".
67	TI5	I	For IC testing. Normally connected to ground. (or unconnected.)
68	VLDY	0	Output for IC testing.
69	DASYO	0	Output for IC testing.
70	SAOUT	0	Digital out output.
71	DAIN	I	For IC testing. Normally connected to ground. (or unconnected.)
72	DASEL	I	Digital out select.
73	TI8	I	For IC testing. Normally connected to ground. (or unconnected.)
74	C2F1	0	Error status display for C2 correction.
75	C2F0	0	Output s whether or not correction was accomplished.
76	C1F1	0	Error status display for C1 correction. Outputs the error count for C2.
77	C1F0	0	Output s whether or not correction was accomplished.
78	MUT1	I	Muting input. Muted when "H".
79	VDD	-	Power supply. (+5V)
80	GND	-	Ground.
81	AVDD	-	Power supply for analog comparator. (+5V)
82	CPIN	I	Analog comparator input. Plus side.
83	CMIN	I	Analog comparator input. Minus side.
84	AGND	-	Ground for analog comparator.
85	IM4	I	For IC testing. Normally connected to ground. (or unconnected.)
86	VDD	-	Power supply. (+5V)
87	DIN	I	For IC testing. Normally connected to ground. (or unconnected.)
88	DOUT	0	Analog comparator output.
89	DOUTB	0	Analog comparator reverse output.
90	CGM	0	9.18MHz output.
91	GND	-	Ground.
92	WINGT	0	For IC testing.
93	SYST0	0	For IC testing.
94	SYST1	0	For IC testing.
95	ADST0	0	For IC testing.
96	ADST1	0	For IC testing.
97	TM5	I	For IC testing. Normally connected to ground. (or unconnected.)
98	BUNR1	I	For IC testing. Normally connected to ground. (or unconnected.)
99	AGND	-	Ground for 46.08MHz transmitter.
100	AVDD	-	Power supply for 46.08MHz transmitter.



## PCM3001E (18-Bit Stereo Audio Codec Single Ended Analog Input/Output)

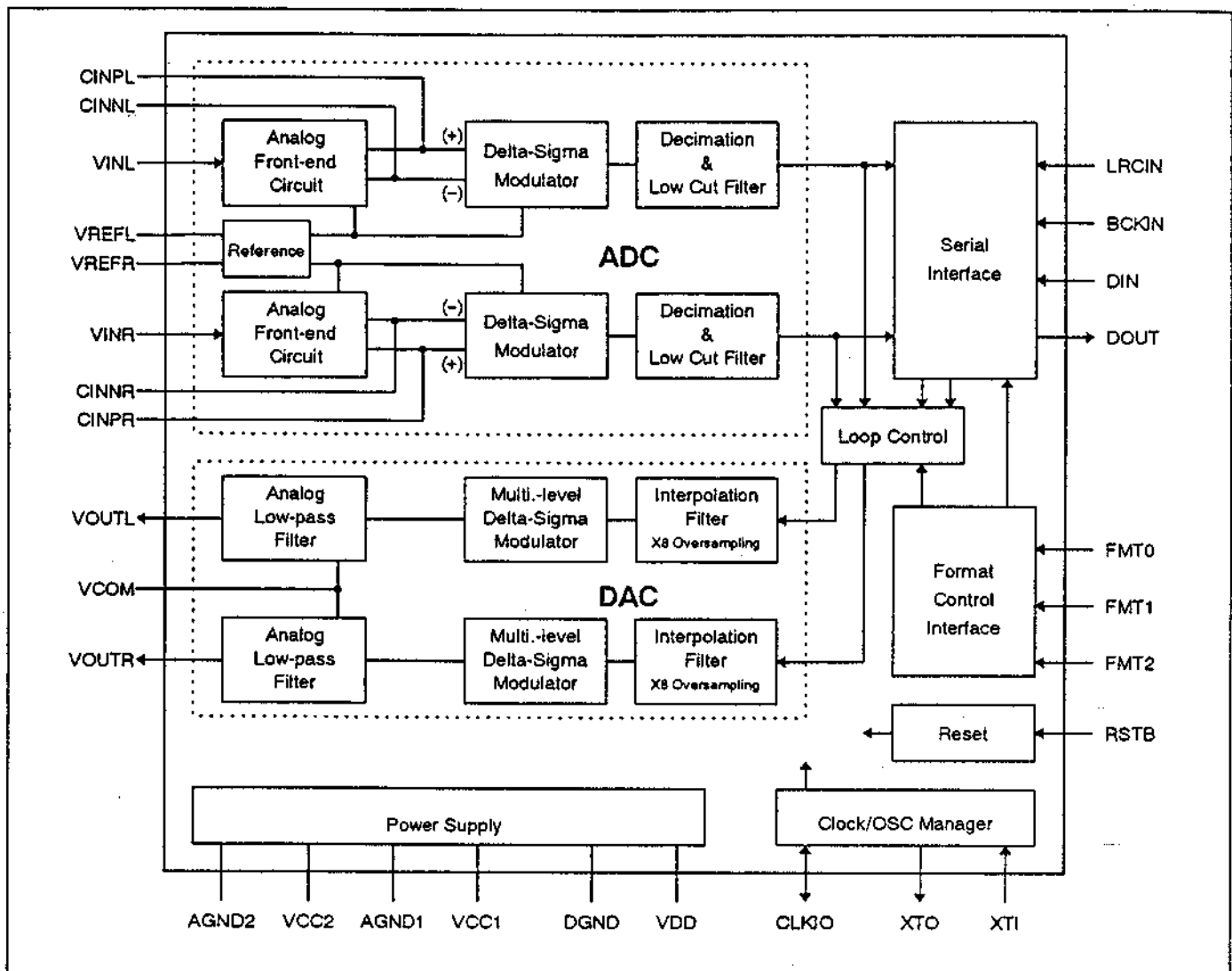

PIN	NAME	I/O	DESCRIPTION	PIN	NAME	I/O	DESCRIPTION
1	VINL	I	ADC analog Input, Lch	15	VOUTL	O	DAC analog output, Lch.
2	VCC1		ADC analog power supply	16	LRCIN	I	sample rate clock input
3	AGND1		ADC analog ground	17	BCKIN	I	Bit clock input
4	VREFL		ADC input reference, Lch	18	DIN	I	Data input
5	VREFR		ADC input reference, Rch	19	DOUT	O	Data output
6	VINR	I	ADC analog input, Rch	20	XT1	I	Oscillator input
7	CINPR		ADC anti-alias filter capacitor (+), Rch	21	XTO	O	Oscillator output
8	CINNR		ADC anti-alias filter capacitor (-), Rch	22	CLKIO	I/O	Buffered output of oscillator or external clock input
9	CINNL		ADC anti-alias filter capacitor (-), Lch	23	VDD		Digital power supply
10	CINPL		ADC anti-alias filter capacitor (+), Lch	24	DGND		Digital ground
11	VCOM		DAC output common	25	FMT2	I	Audio data format select 2
12	VOUTR	O	DAC analog output, Rch	26	FMT1	I	Audio data format select 1
13	AGND2		DAC analog ground	27	FMT0	I	Audio data format select 0
14	VCC2		DAC analog power supply	28	RSTB	I	Reset

## PCM1718E (D/A Converter)

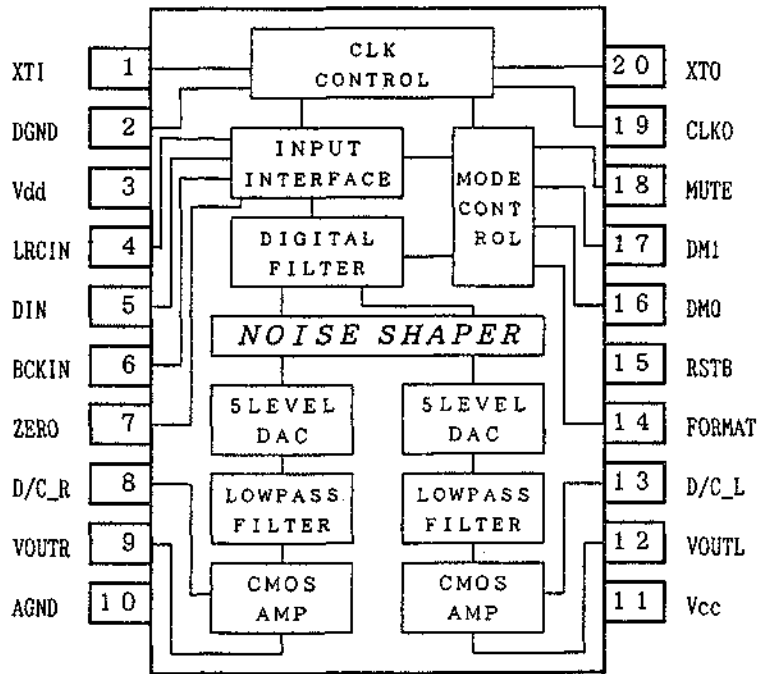

PIN NO.	SYMBOL	FUNCTION	PIN NO.	SYMBOL	FUNCTION
1	XTI	Oscillator input or external clock input	11	Vcc	Analog power supply
2	DGND	Digital ground	12	VOUTL	Analog voltage output of LEFT channel
3	VDD	Digital power supply	13	D/C-L	Common terminal of output amplifier of left channel
4	LRCIN	Reference sampling clock input	14	FORMAT	data format control
5	DIN	Data input	15	RSTB	Reset
6	BCKIN	Bit clock input for data	16	DM0	De-emphasis control
7	ZERO	Infinity zero flag output	17	DM1	De-emphasis control
8	D/C-R	Common terminal of output amplifier of right channel	18	MUTE	Muting control
9	VOUTR	Analog voltage output of right channel	19	CLKO	Inversion output of XTI
10	AGND	Analog ground	20	XTO	Oscillator output pin

## 74HC04 (Hex Inverter)

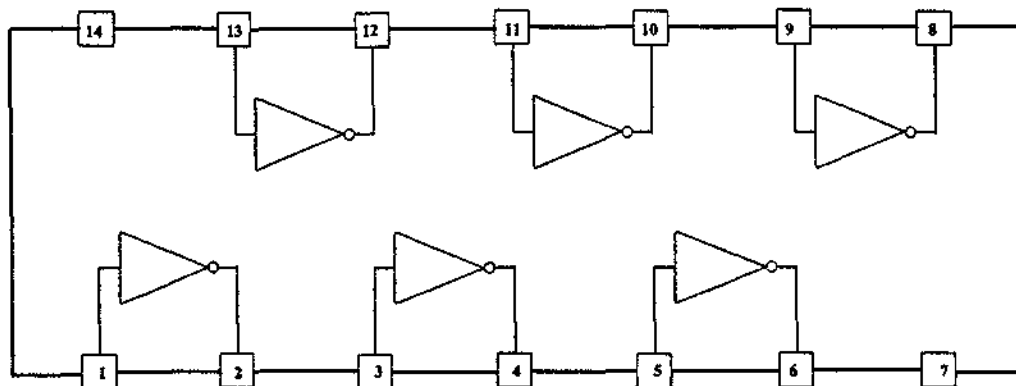

# LC74761 (TV Character/Pattern Indicator)

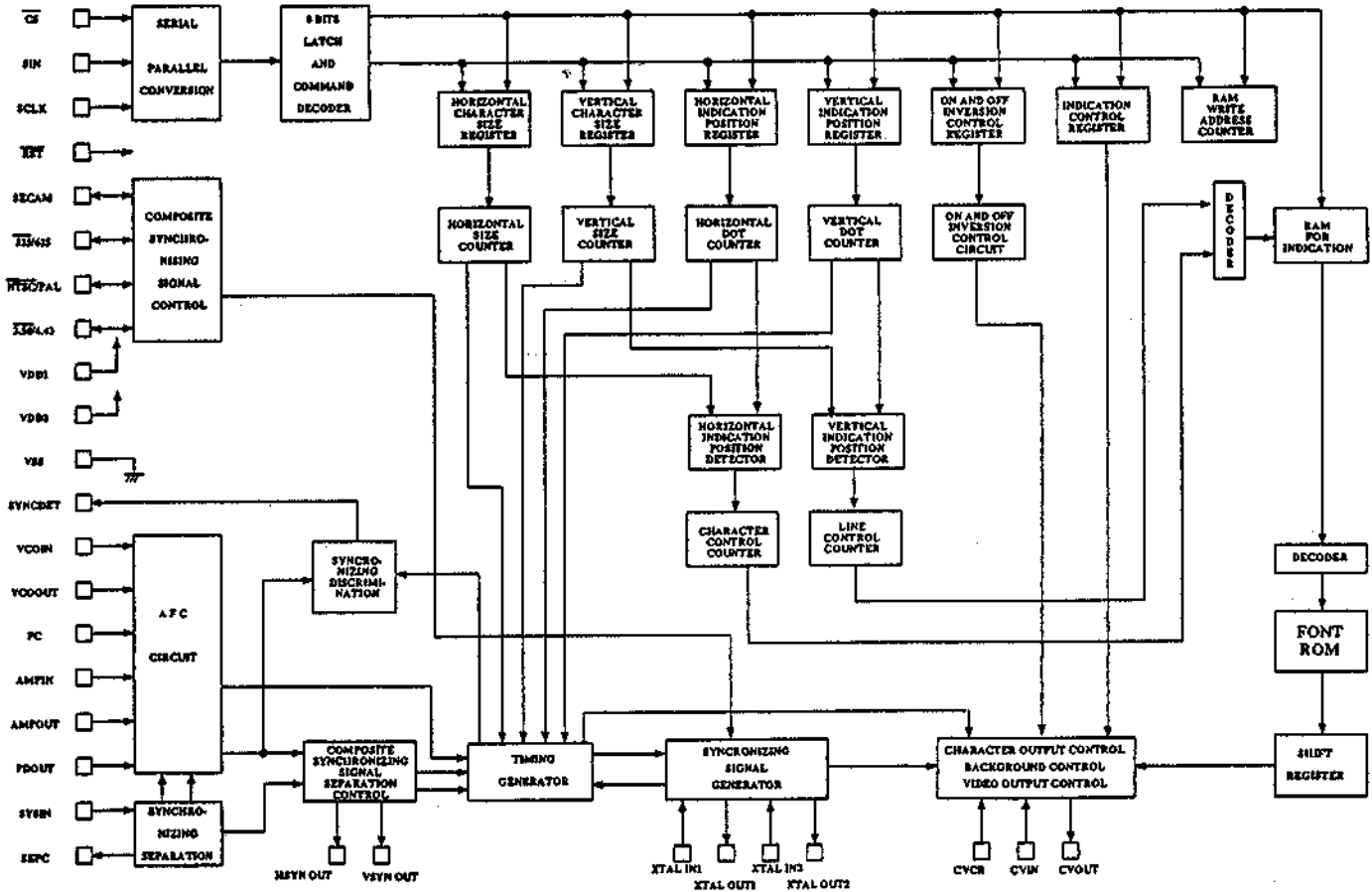

Pin No.	Symbol	Description	Pin No.	Symbol	Description
1	VSS	Ground pin	16	CVOUT	Composite video signal output pin
2	XTAL IN1	Crystal resonator connection pin for internal synchronizing signal generation	17	VDD2	Power supply pin for Composite video signal
3	XTAL OUT1	Horizontal synchronizing signal output pin	18	CVIN	Composite video signal input pin
4	HVSYNOUT	Horizontal synchronizing signal output pin	19	CVCR	Chroma signal input pin for SECAM
5	XTAL IN2	Crystal resonator connection pin for internal synchronizing signal generation	20	SYNCIN	Video signal input pin for internal synchronizing separation circuit
6	XTAL OUT2	Vertical synchronizing signal output pin	21	SEPC	Bias output pin for internal synchronizing separation circuit
7	VVSYNOUT	Vertical synchronizing signal output pin	22	VSS	Ground pin
8	CS	Chip enable input pin for serial data input	23	PDOUT	Voltage output pin for AFC circuit
9	SIN	Serial data input pin	24	AMPIN	Filter connection pin
10	SCLK	Clock input pin for serial data	25	AMPOUT	
11	SECAM	SECAM mode selector input pin	26	FC	Voltage output pin for AFC circuit
12	525/625	Selector pin for scansion line	27	VCOIN	LC resonator connection pins for VCO
13	NTSC/PAL	Selector pin for NTSC or PAL	28	VCOOUT	
14	3.58/4.43	Selector pin for 3.58MHz or 4.43MHz	29	SYNCDET	External synchronizing signal discrimination output pin
15	RST	System reset input pin	30	VDD1	Power supply pin

### M6604FP (FL Tube Driver)

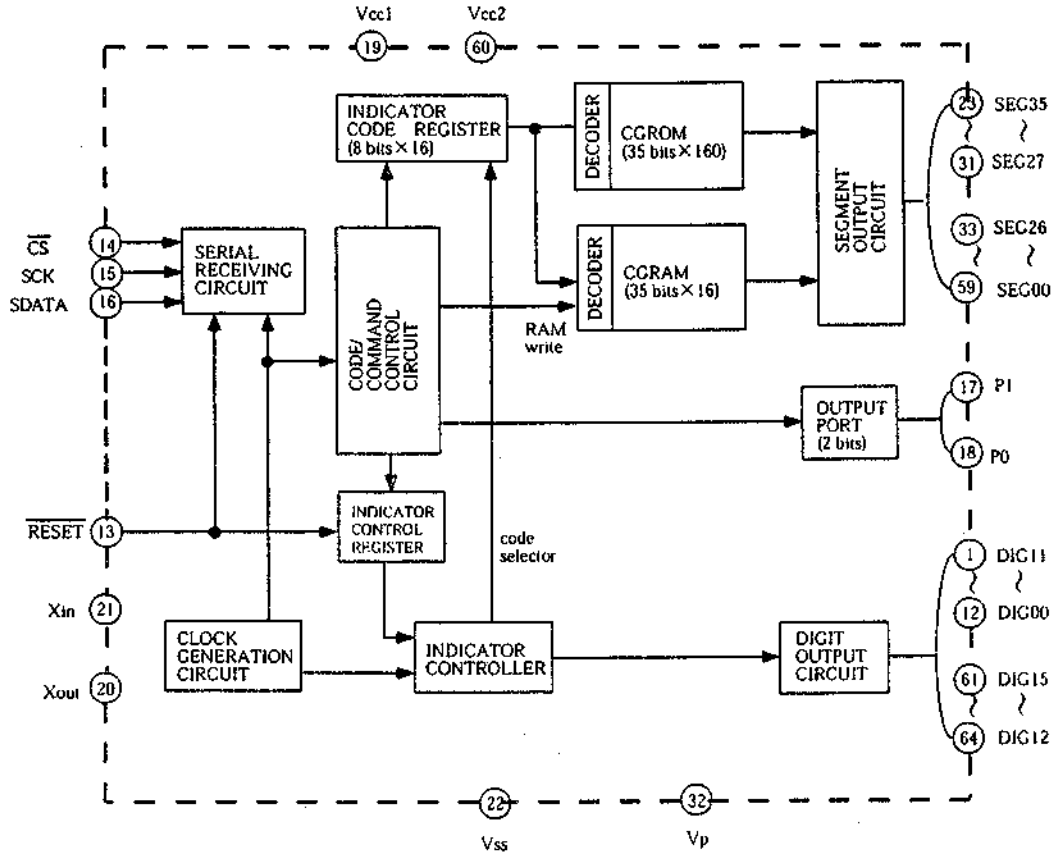

### M5M5256FP-L (RAM)

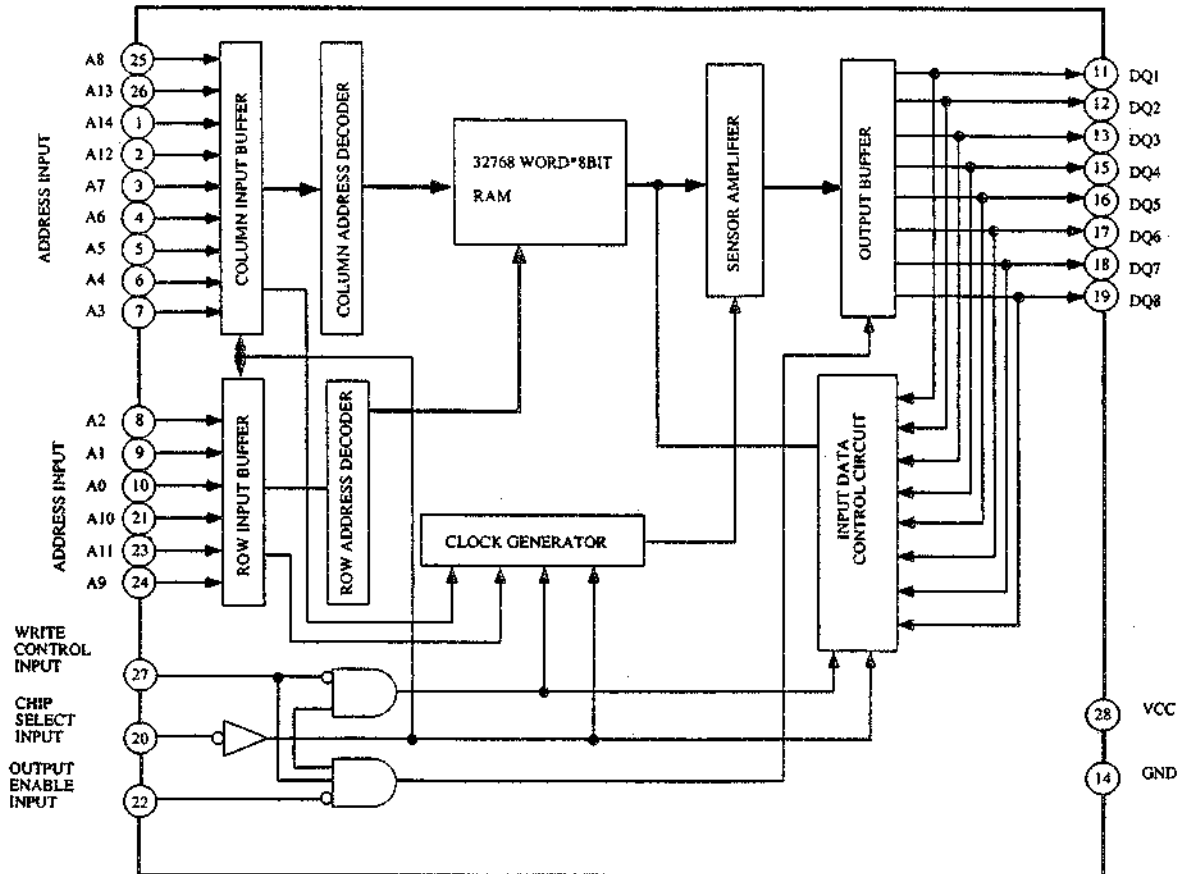

# WIRING DIAGRAM

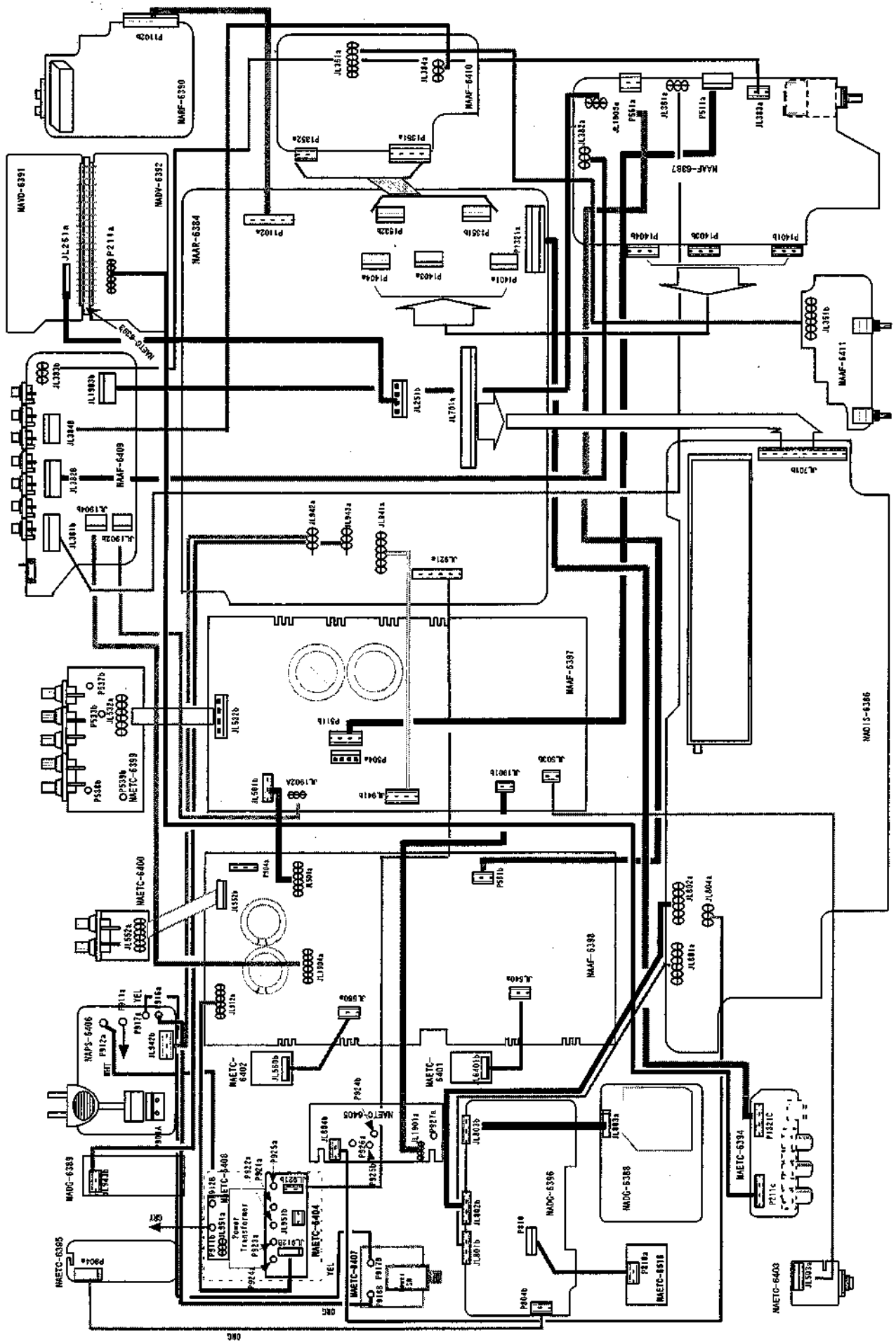

# ELECTRICAL PARTS LIST

CIRCUIT No.	PART No.	DESCRIPTION	CIRCUIT No.	PART No.	DESCRIPTION
<b>Main circuit PC board (NAAR-6384)</b>			<b>Transistors</b>		
<b>Capacitors</b>			Q1707, Q1708	2212600	DTA124ES
C1301, C1308, C1401, C1408 *AH	374721015	100pF±5%, 50V, Plastic	Q1709	2213640	DTC123JS
C1301, C1308, C1401, C1408*B1, B, C	374724714	470pF±5%, 50V, Plastic	<b>Resonator</b>		
C1302, C1309, C1312, C1315, C1318, C1321, C1323, C1325, C1327	354741009	10μF, 50V, Elect.	X1701	3010242	CST5. DOMGW
C1308, C1401, C1408 *AH	374721015	100pF±10%, 50V, Plastic	<b>Resistors</b>		
C1331, C1347, C1415, C1418, C1421, C1423, C1425, C1427, C1431, C1707, C930, C939, C941, C944, C975, C976	354741009	10μF, 16V, Elect.	R926	△ 443522204	22Ω±5%, 1/2W, Metal
C1349	335622230	0.022μF +80% -20%, 50V, Plastic	R947	△ 453530104	1Ω±5%, 1/2W, Metal
C1701, C1704	354721019	100μF, 6.3V, Elect.	<b>Transistors</b>		
C1702	3000076 or 3000078	EEC5SR5T104 or DX-5R5L104, 0.1μF, 5.5V, Miniaturized	Q924	2211354 or 2211353	2SA949-Y or 2SA949-D
C1703	375524744	0.47μF±5%, Plastic	Q1705, Q1706	221282 or 2213560	DTC144ES or RN1204
C1705	354780109	1μF, 50V, Elect.	<b>ICs</b>		
C1715, C947	374721044	0.1μF±5%, Plastic	Q1301	22240191	NJM4565D-D
C1719	354721029	1000μF, 6.3V, Elect.	Q1302-Q1309	22240293 or 22240247	NJM4558L-D or BA15218N
C761, C762	337611040R0	0.1μF, +80% -20%, 50V, Chip cap.	Q1310	22240798	TC9162AN
C923-C926	374731044	0.1μF, ±5%, 50V, Plastic.	Q1311	22240829	TC9274N-008
C931	354761019	100μF, 35V, Elect	Q1312	22240025	LC4966
C932	354772219S	220μF, 6.3V, Elect	Q1701	22241264R3	μPD78P058GC (AV728)
C937, C942	354754719	470μF, 25V, Electric	Q1702	221282 or 2213560	DTC144ES or RN1204
C946	△ 354746829S	6800μF, 16V, Electric	Q1704	22240239	TA7291S
C972	△ 354762229S	2200μF, 35V, Electric	Q921	222780125NEC	78M12HF
<b>Diodes</b>			Q922	222790125JRC	79M12HF
D1701-D1704, D1707-D1708, D940	223163 or 223205 or 223222	1SS133 or 1SS270A or WG713A	Q922b, Q925b, Q927b	838430107	3TTB+10S (BC) screw
D921-D926	22380260 or 22380035 or 22380046	RL1N4003 or GP104003E or AM01Z	Q923	222780078MA	AN7707F
D927, D931, D936-D937	224473604 or 22380022F or 22380285F	MTZJ36D zener or RBV402 or RS403M	Q925, Q927	222780565JRC	78M56 (NJM78M56FA)
D935*AH	22380260	RL1N4003 Diode	Q922a, Q925a	27160391	HEAT SINK
D940	223163 or 223205	1SS133 or 1SS270A	Q927a	27160227	HEAT-SINK (RAD-076)
D941	224470623	MTZJ6.2C Zener	Q926	222790075	79M07HF
<b>Coils</b>			<b>Others</b>		
L1701	233454K220	NCH-1452 220K Choke coil	JL251b	25055631	NPLG-10P593 plug
<b>Plugs</b>			JL701a	25051846	NSCT-39P1633 Socket
P1102a*AH	25055651	NPLG-12P607 Plug	JL921	7J450606H	JL7 450H Jumper lead
P1102a*B1, B, C	25055653	NPLG-16P609 Plug	JL921a	25051111	NSCT-7P898 wire holder
P1321a	25055234	NPLG-3P218	JL941	6J200606H	JL6 200 H Jumper lead
P1351a	25051238	NSCT-13P1028 Socket	JL941a	25051110	NSCT-6P897 wire holder
P1351b	25055709	NPLG-13P665	JL942a	25051087	NSCT-3P874 wire holder
P1352b	25055804	NPLG-4P760	JL943	4J500606B15	JL4 500B (6-6) Jumper lead
P1401a	25055651	NPLG-12P607	JL943a	25051088	NSCT-4P875 wire holder
P1403a	25055652	NPLG-14P608	<b>Display circuit PC board (NADIS-6386)</b>		
P1404a	25055709	NPLG-13P665	<b>Capacitors</b>		
<b>Jacks</b>			C701, C705-C708, C720-C723	337621040R0	0.1μF +80% -20%, 50V, Chip capacitor
P1301-P1304	25045565	NPJ-6PDBL380	C702	355741009	10μF, 16V, Electric.

CIRCUIT No.	PART No.	DESCRIPTION	CIRCUIT No.	PART No.	DESCRIPTION
Fluorescence tube			R342, R345, R346,	433124734R0	47kΩ ± 5%, 1/10W, R.
Q701	212195	16-ST-24GK FL	R362, R419-R426,		
Q701a	27191001	FL holder	R443-R450, R706		
ICs			R343, R352, R354,	433122224R0	2.2kΩ ± 5%, 1/10W, Chip R.
Q702	22240685R9	M66004FP	R358, R360		
Transistors			R344, R411-R418	433122244R0	220kΩ ± 5%, 1/10W, Chip R.
Q704, Q705	2213284 or	2SC1740s-R or	R347, R348, R475-	433121014R0	100Ω ± 5%, 1/10W, Chip R.
	2212115	2SC2458-GR	R363, R364-R370	433420004R0	0Ω, Chip R.
Q708-Q713	2215410R0	RN1441	R391	5142448	N16RGL20KB30F, Variable resistor
Q714	2214530R0	RN2402			
Resistors			R393, R394	433123914R0	390Ω ± 5%, 1/10W, Chip R.
R703, R704	433121014R0	100Ω ± 5%, 1/10W, Chip R.	R395	433122214R0	220Ω ± 5%, 1/10W, Chip R.
R705	49163103415	10kΩ ± 15 Network R.	R396, R401, R402,	433121044R0	100kΩ ± 5%, 1/10W, Chip R.
R708, R718, R726, R754	433121034R0	10kΩ ± 5%, 1/10W, Chip R.	R483-R490		
R711, R719, R727, R733	433123314R0	330Ω ± 5%, 1/10W, Chip R.	R403-R406	433121844R0	180kΩ ± 5%, 1/10W, Chip R.
R714, R722, R730	433128214R0	820Ω ± 5%, 1/10W, Chip R.	R407-R408, R491-	433124744R0	470kΩ ± 5%, 1/10W, Chip R.
R715, R723, R731	433121224R0	1.2kΩ ± 5%, 1/10W, Chip R.	R498, R755		
R716, R724, R732	433122224R0	2.2kΩ ± 5%, 1/10W, Chip R.	R427-R434	433121824R0	1.8kΩ ± 5%, 1/10W, Chip R.
R717, R725	433123924R0	3.9kΩ ± 5%, 1/10W, Chip R.	R435-R442	433123924R0	3.9kΩ ± 5%, 1/10W, Chip R.
R720, R728	433124714R0	470Ω ± 5%, 1/10W, Chip R.	R454, R712	433124714R0	470Ω ± 5%, 1/10W, Chip R.
Others			R459-R466	433120004R0	0Ω, Chip R.
S701-S727	25035675	NPS-111-111-SB28 Tact switch	R467-R474, R701	433122714R0	270Ω ± 5%, 1/10W, Chip R.
U7D1	24130011	P1C-12D43TE2 Remote sensor	Others		
<b>Volume circuit PC board (NAAF-6387)</b>			P561b	2009990241A	NSAS-6P0346 M588F socket ass'y
Capacitors			P1401b	25050985	NSCT-12P772 Socket
C321, C322,	347346804R0	68pF ± 5%, 50V, Chip capacitor	JL1903a	25051090	NSCT-6P877 Socket
C427-C434, C454			JL382a	25051092	NSCT-8P879 Socket
C323-C326, C391-C393,	337621040R0	0.1μF ± 5%, 50V, Chip capacitor	JL381a	25051093	NSCT-9P880 Socket
C475-C482			P1404b	25051238	NSCT-13P1028 Socket
C352, C354, C356,	374721244	0.12μF ± 5%, 50V, Plastic	P504	25055135	NPLG-5P119 Plug
C358, C360, C362			P511a	25055236	NPLG-5P220 Plug
C401-C404, C981, C983	374722234	0.022μF ± 5%, 50V, Plastic	JL383a	25055626	NPLG-5P588 Plug
C411-C418,	354741009	10μF, 16V, Electric.	JL383	5J308606B15	JL5 300 B Jumper lead
C435-C442, C483, C484			JL1903	6J150606B15	JL6 150 B Jumper lead
C419-C426, C443-C450	354782209	22μF, 50V, Electric.	JL382	8J200606B15	Jumper lead
C459-C466	354744709	47μF, 16V, Electric.	<b>AC-3 circuit PC board (NADG-6388)</b>		
C467-C474	354780229	2.2μF, 50V, Electric.	Capacitors		
C486-C500, C715	347341014R0	100pF ± 5%, 50V, Chip capacitor	C107, C129	355721019	100μF, 6.3V, Electric.
Diodes			C108, C116, C130	355744709	CE04W16V-47M Electric.
D301-D303, D401-408,	223234R0	1SS352	C112, C113	347341804R0	18pF ± 5%, 50V, Chip capacitor
D411-D414			C114-C115,	337611040R0	0.1μF ± 5%, 50V, Chip capacitor
D409-D410	224480512R0	DTZ5.1B or	C117-C120, C122,		
	or		C126-C128,		
	224490510R0	UDZ5.1B Zener	C123, C124	354744709	47μF, 16V, Electric.
ICs			C125, C146	337321025R0	1000pF ± 80% - 20%, 50V, Chip capacitor
Q331, Q342, Q343, Q402,	22240581R0	NJM4565M	C891, C892	354742219	220μF, 16V, Electric.
Q409-Q416			C898, C899	354741019	100μF, 16V, Electric.
Q340	22240943R0	TC9163AF	Transistors		
Q405-Q408	22241261R0	LC7535M	Q101, Q103, Q105,	2213143R0	2SC2712-0
Transistors			Q107		
Q333-Q335	2215196	2SK364-BL	Q104, Q109	2214373R0	2SA1162-0
Q337-Q339, Q419-Q450	2215410R0	RN1441	ICs		
Q344, Q345	2214540R0	RN2403	Q108	22240581R0	NJM4565M
Q346	2214480R0	RN1403	Q102	22240976R0	MC14577A
Q435-Q442	2214530R0	RN2402	Q112	22241036R9	MSM5256CFP-70LL
Resistors			Q110	22241107R3	PM4D07A
R331, R332	433123334R0	33kΩ ± 5%, 1/10W, Chip R.	Q894	222780055JRC	78M05 (NJM78M05FA)
R333, R334	433121244R0	120kΩ ± 5%, 1/10W, Chip R.	Q893	222790053JRC	79L05 (NJM79L05A)
R335, R336	433123324R0	3.3kΩ ± 5%, 1/10W, Chip R.			
R337, R338, R352, R354,	433121234R0	12kΩ ± 5%, 1/10W, Chip R.			
R358, R360					
R341	433121054R0	1MΩ ± 5%, 1/10W, Chip R.			

CIRCUIT No.	PART No.	DESCRIPTION	CIRCUIT No.	PART No.	DESCRIPTION
<b>Resistors</b>			C1154, C1166, C1171	354741009	10 $\mu$ F, 16V, Electric.
R101	433125614R0	560 $\Omega$ $\pm$ 5%, 1/10W, Chip R.	C1172, C1175, C1176		
R103, R104, R106, R109-R112, R114, R116, R117, R124	433121024R0	1k $\Omega$ $\pm$ 5%, 1/10W, Chip R.	C1178, C1179		
R105, R115, R121, R128, R981	433124724R0	4.7k $\Omega$ $\pm$ 5%, 1/10W, Chip R.	C1155, C1156*AH	374721034	0.01 $\mu$ F $\pm$ 5%, Plastic.
R107	433121514R0	150 $\Omega$ $\pm$ 5%, 1/10W, Chip R.	C1155, C1156*B1, B, C	374724324	4300pF $\pm$ 5%, Plastic.
R108	433122224R0	2.2k $\Omega$ $\pm$ 5%, 1/10W, Chip R.	C1160, C271, C277	354784799	0.47 $\mu$ F, 50V, Electric.
R113, R119, R126,	433121034R0	10k $\Omega$ $\pm$ 5%, 1/10W, Chip R.	C1162	353741009	10 $\mu$ F, 16V, Electric.
R127, R138, R139, R148, R149			C1168	374724734	0.047 $\mu$ F $\pm$ 5%, 50V, Plastic.
R118	433122234R0	22k $\Omega$ $\pm$ 5%, 1/10W, Chip R.	C1173, C1174	374722724	2700pF $\pm$ 5%, 50V, Plastic.
R120, R435-R442	433123924R0	3.9k $\Omega$ $\pm$ 5%, 1/10W, Chip R.	C1183, C1189*B1, B, C	374724724	4700pF $\pm$ 5%, 50V, Plastic.
R122	433121044R0	100k $\Omega$ $\pm$ 5%, 1/10W, Chip R.	C1184*B1, B, C	374722234	0.022 $\mu$ F $\pm$ 5%, 50V, Plastic.
R123	433123324R0	3.3k $\Omega$ $\pm$ 5%, 1/10W, Chip R.	C1185*B1, B, C	374724734	0.047 $\mu$ F $\pm$ 5%, 50V, Plastic.
R125	433121824R0	1.8k $\Omega$ $\pm$ 5%, 1/10W, Chip R.	C1186*B1, B, C	354780229	2.27 $\mu$ F, 50V, Electric.
R129	433128224R0	8.2k $\Omega$ $\pm$ 5%, 1/10W, Chip R.	C1187, C1188*B1, B, C	374723324	3300pF $\pm$ 5%, 50V, Plastic.
R130, R136	433120004R0	0 $\Omega$ , Chip R.	C1190*B1, B, C	354721019	100 $\mu$ F, 6.3V, Electric.
R132	433126834R0	68k $\Omega$ $\pm$ 5%, 1/10W, Chip R.	C716	355744709	47 $\mu$ F, 16V, Electric.
R133	433121214R0	120 $\Omega$ $\pm$ 5%, 1/10W, Chip R.	<b>Diodes</b>		
R134, R135, R140, R143	433124734R0	47k $\Omega$ $\pm$ 5%, 1/10W, Chip R.	D1565	224470512	MTZJ5.1B Zener
R142	433124704R0	47 $\Omega$ $\pm$ 5%, 1/10W, Chip R.	<b>Coils</b>		
R145, R146, R155	433122214R0	220 $\Omega$ $\pm$ 5%, 1/10W, Chip R.	L1101	233457	NF1F-4081 IF transformer
<b>Resonator</b>			L1102	233458	NF1F-4082 IF transformer
X102	3010279	XTL-18.432M	L1103*B1, B, C	233471	NMC-6084 MPX coil
<b>NAD Link PC board (NADG-6389)</b>			L1104	233454M022	NCH-1452 022M Choke
<b>Capacitors</b>			L1105	232174	NMRF-5077 RF coil
C982	354781099	1 $\mu$ F, 50V, Electric.	L1106	232139	NM1F-4062 IF transformer
C984	337611040R0	0.01 $\mu$ F $\pm$ 5%, 50V, Chip capacitor	L1107, L1108	233484	NMC-4085 MPX coil
C985	337322235R0	CK732BIH 223K Chip capacitor	<b>Terminals</b>		
<b>Diodes</b>			P1101*AH	25060239 or	NTN-4PDML161 or
D981-D984	223234R0	1SS352	P1101*B1, B, C	25060195	NTM-4PDML117 ANT. Terminal
<b>Coils</b>			TU101a	25060222 or	NTM-2PDML144 or
L981	231237K220R0	NCH-1477 Choke coil	TU101a*B1, B, C	25060117	NTM-2PDML051 ANT. Terminal
<b>ICs</b>			<b>Transistors</b>	27150435	ANT. TERMINAL 4P
Q981	22241266	Z86C0812PSC-R2536	Q1101, Q1102, Q1103	27150397	Shield plate
Q982	222740005R0	74HC00	Q1104		
<b>Resistors</b>			Q1122, Q1142, Q1175	2215063	TR 2SC2669-0
R983-R985	433121014R0	100 $\Omega$ $\pm$ 5%, 1/10W, Chip R.	Q1123	2213510 or	DTA114ES or RN2202
R986, R987	433121024R0	1k $\Omega$ $\pm$ 5%, 1/10W, Chip R.	Q1124, Q1171, Q1172	2214350	
R988-R990	433420004R0	0 $\Omega$ , Chip R.	Q1143	2212445	2SK365-GR
<b>Oscillators</b>			Q1144	2213284 or	2SC1740S-R or
X981	3010252	CST12.0MTW Cera lock	Q1173, Q1174	2212115	2SC2458-GR
<b>Others</b>			Q1182*B1, B, C	221282 or	DTC144ES or
JL943b	25055625	NPLG-4P587		2213560	RN1204
P981	25045569	NPJ-2PDYE384 Pin jack	<b>ICs</b>	2213640 or	DTC123JS or
<b>Tuner circuit PC board (NARF-6390)</b>			Q1121	2214660	RN1205
<b>Capacitors</b>			Q1141	2215024	2SD1468S-R
C1101, C1133, C1132, C1142	354741019	100 $\mu$ F, 16V, Electric.	Q1176	2213284 or	2SC1740S-R or
C1127, C227	354721019	100 $\mu$ F, 6.3V, Electric.	Q1181*B1, B, C	2212115	2SC2458-GR
C1130, C1159, C1177	354780229	2.2 $\mu$ F, 50V, Electric.	<b>Resistors</b>	22240293 or	NJM4558L-D or
C1131, C274	374722234	0.022 $\mu$ F $\pm$ 5%, 50V, Plastic.	R1150	22240247	BA15218N
C1132, C1153	354783399	0.33 $\mu$ F, 50V, Electric.	R1158	22240679	MPC1346CS
C1145, C1149	354780479	4.7 $\mu$ F, 50V, Electric.	R1159		
C1146	374723324	3300pF $\pm$ 5%, 50V, Plastic.	R1191	5210261	N06HR5KBC Trim
C1147*AH	374721534	0.015 $\mu$ F $\pm$ 5%, 50V, Plastic.	<b>Terminals</b>	5210264	N06HR30KBC Trim
C1147*B1, B, C	374721034	0.01 $\mu$ F $\pm$ 5%, 50V, Plastic.	TP1101, TP1102	5210265	N06HR50KBC Trim
C1151, C1152	354780109	1 $\mu$ F, 50V, Electric.	<b>Frontends</b>		
			TU101*AH	240098	ENV172D1G1 Frontend
			TU101*B1, B, C	240089	FE415-G11 Frontend



CIRCUIT No.	PART No.	DESCRIPTION
<b>Filters</b>		
X1102*B1, B, C	3010071	SFE-10.7MA5 RED
X1101, X1103	3010071	SFE-10.7MA5 RED
X1103*B1, B, C	3010130	SFE10.7M22K
X1104	3010268	CSB456F23
X1105	3010123	SFZ450JL
<b>Resonators</b>		
X1121	3010141	XTL-7.2M
X1181*B1, B, C	3010203	AF6146CG Crystal
<b>Others</b>		
P1102a*AH	25055651	MPLG-12P607 Plug
P1102b*AH	25050985	NSCT-12P772 Socket
P1102b*B1, B, C	25050987	NSCT-16P774 Socket

#### Composite video circuit PC board (NAVD-6391)

CIRCUIT No.	PART No.	DESCRIPTION
<b>Capacitors</b>		
C251-C255	354780229	2.2 $\mu$ F, 50V, Electric.
C256-C259	354724719	470 $\mu$ F, 6.3V, Electric.
C262, C282, C289, C298	354721019	100 $\mu$ F, 6.3V, Electric.
C269	354741009	10 $\mu$ F, 16V, Electric.
C275, C296	354780109	1 $\mu$ F, 50V, Electric.
C280, C297	354744709	47 $\mu$ F, 16V, Electric.
C284, C291	375524744	0.47 $\mu$ F $\pm$ 5%, 50V, Plastic.
<b>Diodes</b>		
D251, D252, D271	223163 or 223205	1SS133 or 1SS270A
<b>Coils</b>		
L271	233454K056	NCH-1452 056K Choke coil
L272, L273	233454K220	NCH-1452 220K Choke coil
<b>ICs</b>		
Q251	22240373	BA7625
Q271	22241071	LC74761-9096
<b>Transistors</b>		
Q252-Q254, Q273-Q275	2213354 or 2212125	2SA933S-R or 2SA1048-GR
Q272	2213284	2SC1740S-R
<b>Resistors</b>		
R263	453530154	1.5 $\Omega$ $\pm$ 5%, 1/2W, Metal
<b>Resonators</b>		
X271	3010167	XTL-14.32M
X272*B1, B, C	3010238	XTL-17.73M Crystal
<b>Sockets</b>		
P251	25045363 or 25045506	NPJ-3PDYE208 or NPJ-3PDYE321 Jack
P252	25045566 or 25045507	NPJ-4PDYE381 or NPJ-3PDYE322 Jack
<b>Others</b>		
JL251a	25051094	NSCT-10P881

#### Video circuit PC board (NAVD-6392)

CIRCUIT No.	PART No.	DESCRIPTION
<b>Capacitors</b>		
C201-C210, C212, C214, C216, C218, C221	354780229	2.2 $\mu$ F, 50V, Electric.
C211, C213, C215, C217, C223	354724719	470 $\mu$ F, 6.3V, Electric.
C219	354744709	47 $\mu$ F, 16V, Electric.
C222	354741009	10 $\mu$ F, 16V, Electric.
C228, C233	354721019	100 $\mu$ F, 6.3V, Electric.
<b>Diodes</b>		
D201-D210	223163 or 223205	1SS133 or 1SS270A

CIRCUIT No.	PART No.	DESCRIPTION
<b>Transistors</b>		
Q203-Q208, Q217	2213354 or 2212125	2SA933S-R or 2SA1048-GR
Q209, Q213-Q215, Q221-Q223	2212286 or 2212285	2SC2878-B or 2SC2878-A
Q210, Q224	2212282 or 2213560	DTC144ES or RN1204
Q211, Q212	2213284 or 2212115	2SC1740S-R or 2SC2458-GR
Q216, Q220	2213640 or 2214660	DTC123JS or RN1205
Q218, Q219	2213510 or 2214350	DTA114ES or RN2202
<b>ICs</b>		
Q201, Q202	22240373	BA7625
<b>Sockets</b>		
P201	25051957	NSCT-12P1744 Socket
P202, P203	25051956	NSCT-8P1743 Socket Video in
<b>Others</b>		
P211a	25055135	MPLG-5P119 plug

#### Front video terminal PC board (NAETC-6394)

CIRCUIT No.	PART No.	DESCRIPTION
P1321c	2009990525UL	NSAS-6P0690 Socket ass'y
P211c	2009990433UL	NSAS-10P0577 Socket ass'y
P212c	2061712140UL	CRIMP AS
P206	25051749	NSCT-4P1536 Socket
P256	25045479A	NPJ-1PDBL297 Jack
P242	25051957	NSCT-12P1744 Socket
P1311, P1312	25045479A	NPJ-1PDBL297 Jack

#### Digital input terminal PC board (NAETC-6395)

CIRCUIT No.	PART No.	DESCRIPTION
<b>Capacitors</b>		
C181, C191	375524744	0.47 $\mu$ F $\pm$ 5%, 50V, Plastic.
C184, C193	374721044	0.1 $\mu$ F $\pm$ 5%, 50V, Plastic.
<b>Diodes</b>		
D191	223163 or 223205	1SS133 or 1SS270A
<b>ICs</b>		
Q181	222749046R00	74HC004 (7C74HC004F)
<b>Photo coupler</b>		
U121	24120037	TORX178A Photo coupler
<b>Others</b>		
P101*AH	25045477	NPJ-1PDBL295 Jack
P101*B1, B, C	25045477	NPJ-1PDBL295 Jack
P102	25045478	NPJ-1PDBL296 Jack
P804a	2009990434UL	NSAS-10P0578 Socket ass'y

#### DSP circuit PC board (NADG-6396)

CIRCUIT No.	PART No.	DESCRIPTION
<b>Capacitors</b>		
C131	347021024R0	1000pF $\pm$ 5%, 50V, Chip. capacitor
C132	337322225R0	2200pF +80%-20%, 50V, Chip. capacitor
C133, C766, C811, C781, C793, C817, C818-C822	354744709	47 $\mu$ F, 16V, Electric
C135	374721034	0.01 $\mu$ F $\pm$ 5%, 50V, Plastic.
C137	347341804R0	18pF $\pm$ 5%, 50V, Chip. capacitor
C138	347341504R0	15pF $\pm$ 5%, 50V, Chip. capacitor
C142, C143, C758, C759, C785, C767, C775, C777	337321035R0	0.01 $\mu$ F +80%-20%, 50V, Chip. capacitor
C145, C814, C815	347021014R0	100pF $\pm$ 5%, 50V, Chip. capacitor
C757	337321235R0	0.012 $\mu$ F +80%-20%, 50V, Chip. capacitor
C760	337361055R2	1 $\mu$ F +80%-20%, 50V, Chip. capacitor
C763, C773	374724734	0.047 $\mu$ F $\pm$ 5%, 50V, Plastic.
C764, C768, C769, C771, C772, C774, C778, C779, C786, C787, C791, C802, C809, C810, C812, C813	337611040R0	0.1 $\mu$ F $\pm$ 5%, 50V, Chip. capacitor

CIRCUIT No.	PART No.	DESCRIPTION	CIRCUIT No.	PART No.	DESCRIPTION
C776, C789	355744709	47 $\mu$ F, 16V, Electric.	ICs		
C794	337322235R0	0.022 $\mu$ F $\pm$ 80% - 20%, 50V, Chip.	Q891, Q892	222780055JRC	78M05 (NJM78M05FA)
C801, C803-C805, C808	354741009	10 $\mu$ F, 16V, Electric.	Q821-Q823	22240581R0	NJM4565M
C806	347024714R0	470pF $\pm$ 5%, 50V, Chip.	Q802, Q803	22241099R0	PCN1718E
C807	347026814R0	680pF $\pm$ 5%, 50V, Chip.	Q801	22241100R0	PCN3001E
C831-C836	354780229	2.2 $\mu$ F, 50V, Electric.	Q791	22241265R3	MPD78PD14GC (AV728)
C837-C842	374722724	2700pF $\pm$ 5%, 50V, Plastic	Q764	22240928R0	TC9246F
C843-C848	374721524	1500pF $\pm$ 5%, 50V, Plastic	Q763	22241101R0	LC32464M-80
C849-C854	374721224	1200pF $\pm$ 5%, 50V, Plastic	Q762	22240940R3	DSP56004FJ66
C855-C860	354782209	22 $\mu$ F, 50V, Electric.	Q761	22241219R3 or	DSPF56009FJ88 or
C861, C862, C893, C894	354741019	100 $\mu$ F, 16V, Electric.		22241235R3	XCF56009FJ88
C871, C872	337622230R0	0.022 $\mu$ F $\pm$ 80% - 20%, 50V, Chip	Q131	22240915R3	LC8904Q
C871, C872*AH	337622230R0	0.022 $\mu$ F $\pm$ 80% - 20%, 50V, Chip	Transistors		
C896	354742219	220 $\mu$ F, 16V, Electric.	Q569, Q596	2213354	2SA933S-R
Diodes			Coils		
D101	223236R0	KV1851-TL	L761, L762	231237M022R0	NCH-1471
D131, D132	223234R0	1SS352	L147, L102-L105	231237K470R0	NCH-1479 Choke coil
Resistors			L101	233493K680	COIL NCH-1487 680K
R151, R821-R826	433125634R0	56k $\Omega$ $\pm$ 5%, 1/10W, Chip R.	Sockets		
R152, R157	433123344R0	330k $\Omega$ $\pm$ 5%, 1/10W, Chip R.	JL801b, JL802b	25050286	NSCT-9P114 Socket
R153	433126834R0	68k $\Omega$ $\pm$ 5%, 1/10W, Chip R.	JL803b*AH	25050284	NSCT-7P112 Socket
R158-R160	433126804R0	68 $\Omega$ $\pm$ 5%, 1/10W, Chip R.	P804b	25055135	NPLG-5P119
R161	433123334R0	33k $\Omega$ $\pm$ 5%, 1/10W, Chip R.	P805	2067713121UL	CRIMP AS
R162, R173-R176, R800	433121024R0	1k $\Omega$ $\pm$ 5%, 1/10W, Chip R.	P806	2067713150UL	CRIMP AS
R163	433122434R0	24k $\Omega$ $\pm$ 5%, 1/10W, Chip R.	Resonators		
R164, R165	433125624R0	5.6k $\Omega$ $\pm$ 5%, 1/10W, Chip R.	X791	3010239	CST10.0MTW
R166	433121514R0	150 $\Omega$ $\pm$ 5%, 1/10W, Chip R.	X131	3010266	XTL-18.432M
R167	433122244R0	240k $\Omega$ $\pm$ 5%, 1/10W, Chip R.	<u>Front and center power amplifier PC board (NAAF-6397)</u>		
R168, R872	433121014R0	100 $\Omega$ $\pm$ 5%, 1/10W, Chip R.	Capacitors		
R169, R178, R198	433124714R0	470 $\Omega$ $\pm$ 5%, 1/10W, Chip R.	C1502, C502, C602	354782209	22 $\mu$ F, 50V, Electric.
R170, R171, R741,	433122214R0	220 $\Omega$ $\pm$ 5%, 1/10W, Chip R.	C1505, C505, C605	354742219	220 $\mu$ F, 16V, Electric.
R762-R764,			C1514, C1515, C514,	354764709	47 $\mu$ F, 35V, Electric.
R766-R777, R779,			C515		
R781, R782, R784,			C1533-C1536	354771009	10 $\mu$ F, 63V, Electric.
R786, R786-R797			C1931, C1932	354744709	47 $\mu$ F, 16, Electric.
R707	433122734R0	27k $\Omega$ $\pm$ 5%, 1/10W, Chip R.	C517, C566, C617,	374721044	0.1 $\mu$ F $\pm$ 5%, 50V, Plastic.
R713, R721, R729	433125614R0	560 $\Omega$ $\pm$ 5%, 1/10W, Chip R.	C666, C1517		
R744, R892, R154, R179	433120004R0	0 $\Omega$ , Chip R.	C521, C522, C621, C622	354774719S	470 $\mu$ F, 63V, Electric.
R747, R891	433121034R0	10k $\Omega$ $\pm$ 5%, 1/10W, Chip R.	C523, C1523	354722219	220 $\mu$ F, 6.3V, Electric.
R756-R761, R982	433121044R0	100k $\Omega$ $\pm$ 5%, 1/10W, Chip R.	C541	354721019	100 $\mu$ F, 6.3V, Electric.
R765, R778, R798	433124734R0	47k $\Omega$ $\pm$ 5%, 1/10W, Chip R.	C542, C594	354780229	2.2 $\mu$ F, 50V, Electric.
R799, R874, R881	433120474R0	4.7 $\Omega$ $\pm$ 5%, 1/10W, Chip R.	C913, C914	3504346S	12000 $\mu$ F, 63V, Electric.
R801-R805, R808,	433122214R0	220 $\Omega$ $\pm$ 5%, 1/10W, Chip R.	C915, C916*AH	374731044	0.1 $\mu$ F $\pm$ 5%, 50V, Plastic.
R809, R871, R878,			C915, C916*B1, B, C	374731044	0.1 $\mu$ F $\pm$ 5%, 50V, Plastic.
R882, R883			Diodes		
R811-R816, R873,	433120004R0	0 $\Omega$ , Chip R.	D1901	22380012F	HER303F
R885, R780, R783,			D991, D992,	223163 or	1SS133 or
R806, R807, R745,			D1902-D1905,	223205	1SS270A
R746, R749, R752,			D1933-D1938, D1941		
R753, R172, R150, R156			D1909	226065	SF8JZ47 SCR
R819, R820	433122234R0	22k $\Omega$ $\pm$ 5%, 1/10W, Chip R.	D1909b, D1910b	838430107	3TTB+10S (BC) Screw
R827-R844	433122224R0	2.2k $\Omega$ $\pm$ 5%, 1/10W, Chip R.	D1931, D1932	224471802	MTZJ18B Zener
R845-R856	433124724R0	4.7k $\Omega$ $\pm$ 5%, 1/10W, Chip R.	D501, D502, D601,	22380260 or	RL1N4003 or
R857-R862	433122204R0	22 $\Omega$ $\pm$ 5%, 1/10W, Chip R.	D602	22380032 or	1SR139-100 or
R876	433123914R0	390 $\Omega$ $\pm$ 5%, 1/10W, Chip R.		22380035	GPTD4003E
			Transistors		
			Q509, Q609Q1509	2203010	2SC5171
			Q501, Q502, Q516,	2211733 or	2SC1845-E or
			Q1501, Q1502, Q1516	2211732	2SC1845-F
			Q518, Q1518, Q601,		
			Q602, Q616, Q618		

CIRCUIT No.	PART No.	DESCRIPTION	CIRCUIT No.	PART No.	DESCRIPTION
Q503, Q541, Q542,	2213284 or	2SC1740S-R or	R529, R530, R545, R5	△ 453530224	2.2Ω ± 5%, 1/2W, Metal
Q594, Q1503, Q603, Q654	2212115	2SC2458-GR	R1529, R1530		
Q508	* 2212654 or	2SC3421-Y or	R535, R536, 635, R63	△ 4500200	560Ω ± 5%, 1/4W, Metal
Q513	2212653	2SC3421-O	R1535, R1536		
Q514	* 2202833 or	2SA1962-O or	R540, R640, R1540	△ 453630824	8.2Ω ± 5%, 1W, Metal
Q563	2202832	2SA1962-R	R547, R647	△ 443623914	390Ω ± 5%, 1W, Metal
Q564	* 2202843 or	2SC5242-O or	R582, R638, R682	△ 4000132	0.22Ω ± 5%, 5W, Metal
Q608	2202842	2SC5242-R	Relays		
Q613	* 2202843 or	2SC5242-O or	RL501, RL502	△ 25065517	NRL-2P5A-DC24-D98
Q614	2202842	2SC5242-R	Terminals		
Q663	* 2202843 or	2SC5242-O or	TP1544, TP544, TP64	25055038	NPLG-2P29
Q664	2202842	2SC5242-R	4		
Q1508	* 2212654 or	2SA1962-O or	Others		
Q1513	2212653	2SA1962-R	JL1901b	25055625	NPLG-4P587
Q1514	* 2202833 or	2SC3421-Y or	JL1902	3J150606B15	JL3 150 B(6-6)
R1577, R1943	4000149	2SC3421-O	JL501	4J300606H	JL4 300 H
Q504-Q506, Q511, Q604-Q606, Q611, Q1504-Q1506, Q1511	2211354 or	2SA1962-O or	JL501b	25050268	NSCT-4P96
Q507, Q512, Q517, Q519, Q1507, Q1512, Q1517, Q1519, Q617, Q619	2211353	2SA1962-R	JL503	5J450606B15	Jumper lead
Q508, Q1508, Q608	* 2212654 or	2SC3421-Y or	JL503b, JL804b	25055626	NPLG-5P588
Q513, Q1513, Q613	2212653	2SC3421-O	JL532	6J200606H	JL6 200 H
Q514, Q1510	* 2202833 or	2SA1962-O or	JL532b, JL941b	25050270	NSCT-6P98
Q514, Q614, Q1514	2202832	2SA1962-R	P511b	2009990382	NSAS-10P0519 Socket ass'y
Q520, Q620, Q1941, Q1520	2213354	2SA1962-R	P552	25055133	NPLG-3P117 Plug
Q961, Q1901, Q1902	2211792 or	2SC2229-Y or	<b>Surround power amplifier PC board (NAAF-6398)</b>		
Q991, Q992	2211793	2SC2229-O	<b>Capacitors</b>		
Resistors	2213640	DTC123JS	C552, C652	354742209	22μF, 16V, Electric.
R1541	△ 443522724	2.7kΩ ± 5%, 1/2W, Metal oxide	C555, C655	354741019	100μF, 16V, Electric.
R1901, R1902, R1945	△ 4500014	0.1Ω ± 5%, 5E, Metal	C557, C558, C575, C576	354771009	10μF, 63V, Electric.
R1943	4000149	PTH9M04BB222TS2F333 Thermistor	C564, C565, C593, C614, C615, C664, C665	354764709	47μF, 50V, Electric.
R506, R606, R1506	△ 443526834	68kΩ ± 5%, 1/2W, Metal oxide	C571, C572	354771019	100μF, 63V, Electric.
R513, R613, R1513, R1569	△ 443525614	560Ω ± 5%, 1/2W, Metal oxide	C573, C623, C673	354722219	220μF, 6.3V, Electric.
R514, R517, R614, R617, R566, R666, R1514, R1517	△ 443528204	82Ω ± 5%, 1/2W, Metal oxide	C595, C596	374722234	0.022μF ± 5%, 50V, Plastic.
R515, R615, R1515	△ 443526804	68Ω ± 5%, 1/2W, Metal oxide	C597	354781009	10μF, 50V, Electric.
R516, R616, R1516	4500199	470Ω ± 5%, 1/4W, Metal oxide	C917, C918	△ 3504347S	8200μF, 56V, Electric.
R522, R572, R622, R672, R1522	4500116	820Ω ± 5%, 1/4W, Metal oxide	C971	354763329S	3300μF, 35V, Electric.
R523, R571, R623, R671, R1523	4500116	820Ω ± 5%, 1/4W, Metal oxide	Diodes		
R524, R563, R564, R567, R1524	△ 443521014	100Ω ± 5%, 1/2W, Metal oxide	D915	△ 22380281	RS604
			D915a	27160166	Heat sink
			D915b	82143015	3P+15FN(BC) Screw
			Transistors		
			Q551-Q553, Q566,	2211733 or	2SC1845-E or
			Q551-Q653, Q666	2211732	2SC1845-F
			Q554	2213284 or	2SC1740S-R or
			Q555-Q557,	2212115	2SC2458-GR
			Q555-Q657	2211354 or	2SA949-Y or
			Q558, Q559, Q565,	2211353	2SA949-O
			Q607, Q612, Q658,	2211634 or	2SC2229-Y or
			Q659, Q665	2211633	2SC2229-O
			Q661, Q661	2203010	2SC5171
			Q663, Q564, Q663,	2202833 or	2SA1962-O or
			Q664	2202832	2SA1962-R
			Q593	2212445	2SK365-GR
			Q595	* 2212644	2SA1358-Y
			Q669	2213354	2SA933S-R

**NOTE:**

Replacement of the transistor of mark \*, if necessary, must be made from the same beta group (HFE) as the original type.

CIRCUIT No.	PART No.	DESCRIPTION
<b>Resistors</b>		
R1571, R1572	443525614	560Ω ±5%, 1/2W, Metal
R1572	443521024	1kΩ ±5%, 1/2W, Metal
R1574	△ 443725604	56Ω ±5%, 2W, Metal
R1577	△ 4000149	PTHM04BB222TS2F333 Thermistor
R556, R656	△ 443525634	56kΩ ±5%, 1/2W, Metal
R565, R665	443525604	56Ω ±5%, 1/2W, Metal
R573, R624, R663, R664, R667, R673	△ 443521014	100Ω ±5%, 1/2W, Metal
R574, R575, R588, R589, R629, R630, R645, R646, R674, R675	△ 453530224	2.2Ω ±5%, 1/2W, Metal
R576, R676	△ 453630824	8.2Ω ±5%, 1W, Metal
<b>Terminals</b>		
TP578, TP678	△ 25055038	NPLG-2P29
<b>Sockets</b>		
P561a	25055234	NPLG-3P21B
P904a	25055600	NPLG-2P568 plug
<b>Others</b>		
JL1904	6J300606B15	JL6 300 B
JL1904a	25051090	NSCT-6P877
JL501a, JL912a	25051108	NSCT-4P895
JL552b	25050268	NSCT-4P96
JL560, JL660	3J100606B15	JL3 100 B(7-7)
JL560a, JL660a	25051087	NSCT-3P874

#### Speaker terminal PC board (NAETC-6399)

P501	25060203 or 25060248	NTW-8PDMN125 or NTW-8PDMN168 Terminal
P502	25060282 or 25060247	NTW-2PDMN213 or NTW-2PDMN167 Terminal
JL532a	25051110	NSCT-6P897

#### Surround speaker terminal PC board (NAETC-6400)

P551	25060193 or 25060246	NTW-4PDMN115 or NTW-4PDMN166 Terminal
JL552	4J150606H	JL4 150 H
JL552a	25051108	NSCT-4P895

#### Thermal compensation PC board (NAETC-6401)

JL560b	25055624	NPLG-3P586
Q560	2212654	2SC3421-Y, transistor

#### Thermal compensation PC board (NAETC-6402)

JL660b	25055624	NPLG-3P586
Q660	2212654	2SC3421-Y, transistor

#### Headphone terminal PC board (NAETC-6403)

JL503a	25051089	NSCT-5P876
P503	25045385	YKB26-5153 Jack

#### Secondary circuit PC board (NAETC-6404)

<b>Capacitors</b>		
C921, C922, C927, C928	374721044	0.1μF ±5%, 50V, Plastic.
<b>Resistors</b>		
R921, R922, R929, R930	△ 453532294	0.22Ω ±5%, 1/2W, Metal
<b>Fuses</b>		
F915, F916*AH	△ 252166	Fuse 6.3A-UL/T-237
F915, F916*B1, B, C	△ 252079	Fuse 6.3A-SE-EAK
<b>Others</b>		
F915a, F916a	25050065	YSH403T Fuse holder
F916b*AH	29362027	6.3A/125V Fuse label

CIRCUIT No.	PART No.	DESCRIPTION
JL912	4J300606H	JL4 300 H Jumper wire
JL912b	25050268	NSCT-4P96 Socket
JL921b	25050271	NSCT-7P99 Socket
JL942b, JL951b	25055624	NPLG-3P586 plug
JL951	3J350606B15	JL3 350 B Jumper lead

#### Regulator circuit PC board (NAETC-6405)

<b>ICs</b>		
Q1903	22240293 or 22240247	NJM4558L-D or BA15218N
<b>Transistors</b>		
Q1905, Q1908	2211255	2SC1815-GR
Q1906, Q1907	2211455	2SA1015-GR
<b>Capacitors</b>		
C1901, C1902, C1904	355781009	10μF, 50V, Electric.
C1905		
C1903	374721044	0.1μF ±5%, 50V, Plastic.
<b>Diodes</b>		
D1907	223163 or 223205	1SS133 or 1SS270A
D1910	226065	SF8JZ47 SCR
D1911	△ 22380273	RS804M
D1911a	27160423	AL t=2mm Heat sink(SCR)
D1911b	838430107	3TTB+10S (BC) Screw
D911	22380273	RS804M
<b>Others</b>		
JL1901	4J300606B15	JL4 300B Jumper wire
JL1901a	25051088	NSCT-4P875
JL804	5J200606B15	JL5 200B(6-6)

#### Power supply circuit PC board (NAPS-6406)

<b>Capacitors</b>		
C901	△ 3500191	0.01μF ±5%, 50V, IS Capacitor
C952	354744719	470μF, 16V, Elect.
<b>Fuses</b>		
F901*AH	△ 252166	Fuse 6.3A-UL/T-237
F902 *B1, B, C	△ 252077 or 252077CC	Fuse 4A-SE-EAK
<b>Diodes</b>		
D591-D592	22380260 or 22380032 or 22380035	RLN4003 or 1SR139-100 or GP104003E
D951-Q955	22380032 or 22380035	1SR139-100 or GP104003E
<b>Fuse holders</b>		
F901a*AH	25050065	YSH403T Fuse holder
F902a*B1, B, C	25050065	YSH403T Fuse holder
<b>Resistors</b>		
R901*AH	△ 431533355	RC1/2GFKUL-3.3M Solid resistor
R951	△ 453530824	RNUF/2WCJ-0.2 Metal
<b>Relay</b>		
RL901*AH	△ 25065248 or 25065516	NRL-1P15A-DC12-29 or 2300670A Relay
RL901*B1, B, C	△ 25065515 or 25065508	NRL-1P5A-DC12-096 or NRL-1P10A-DC12-093 Relay
<b>Transformers</b>		
T902*AH	△ 2301258 or 2300670A	NPT-12940 or NPT-1111D TX906ND
T902*B1, B, C	△ 2300671A	NPT-1111P TX906NP
<b>Others</b>		
P901a	△ 25055675	NPLG-2P631 plug for AC cord
JL942	3J500606B15	JL3500B(7-7) Jumper lead
P902*AH	△ 25051220	NSCT-6P1010 Socket

CIRCUIT No.	PART No.	DESCRIPTION
<b>Power switch PC board (NAETC-6407)</b>		
C902	△ 3500191	0.01 μF ± 5%, 50V, IS capacitor
C902a	27301216	SB1925A, Capacitor cover
S902	△ 25035550	NPS-111-L512P Power switch

**Terminal PC board (NAETC-6408)**

JL951a	△ 25051087	NSCT-3P874 Holder
P909*B1, B, C	27141059	Retainer
P918*AH	2069925119UL	Clamper AS

**Pre-output terminal PC board (NAAF-6409)**

Capacitors		
C1951, C1953	354741019	100 μF, 16V, Electric.
C301-C303,	374723324	3300pF ± 5%, 50V, Plastic
C305-C308*B1, B, C		
C304*B1, B, C	374722234	0.022 μF ± 5%, 50V, Plastic
C309-C313	374721015	100pF, ± 5%, 50V, Plastic
C314	374721024	1000pF, ± 5%, 50V, Plastic
C319, C320	374721044	0.1 μF, ± 5%, 50V, Plastic
Diodes		
D1951	224470512	NTZJ5.1B Zener
D1952-D1954	223163 or 223205	1SS133 or 1SS270A
D1955, D1956	223205	1SS270A
Jacks		
P301, P304	25045357 or 25045509	NPJ-2PDBL203 or NPJ-2PDBL324 pin jack
P302	25045565	NPJ-6PDBL380 pin jack
P303	25045491	NPJ-4PDBL308
Transistors		
Q1955-Q1959-Q1963,	2211255	2SC1815-GR
Q1951-Q1954		
Others		
S1951	25065286	NSS-22112 slide switch
JL1902a	25051087	NSCT-3P874
JL1902b	25055624	NPLG-3P586 plug
JL1904b	25055627	NPLG-6P589 plug
JL381	9J250606B15	JL9 25D B Jumper lead
JL382b	25055629	NPLG-8P591 plug
JL383b, JL384a	25051089	NSCT-5P876 Holder
JL384	3J350606B15	JL3 350 B Jumper lead
JL384b	25055626	NPLG-5P588 plug

**Tone control circuit PC board (NAAF-6410)**

Capacitors		
C135, C140, C141, C151	337611040RD	0.1 μF ± 80% - 20%, 50V, Chip
C1361, C1381, C1461,	354741009	10 μF, 16V, Electric.
C1953		
C1367, C1387, C1467	354744709	47 μF, 16V, Electric.
C1368, C1373, C1388,	374721534	0.015 μF ± 5%, 50V, Plastic.
C1393, C1468, C1473		
C1370	374721044	0.1 μF ± 5%, 50V, Plastic.
C1402, C1409, C1412	354741009	10 μF, 16V, Electric.
C1451, C1452	354780479	4.7 μF, 50V, Electric.
Diodes		
D1451-D1453	223163 or 223205	1SS133 or 1SS270A

CIRCUIT No.	PART No.	DESCRIPTION
<b>ICs</b>		
Q1451-Q1452, Q1455	22240293 or 22240247	MUM4558L-D or BA15218N
Q1462, Q1463, Q1464	22240025	LC4966
Transistors		
Q1453, Q1454, Q1456	2215196	2SK364-BL
Q1457, Q1459, Q1461	221281	DTC114YS
Q1466, Q1467		
Q1458, Q1460	2213090	DTA114YS
Others		
JL351	2J200606B15	JL12 200B(6-6) Jumper lead
JL351a	25051096	NSCT-12P883 Holder
P1352a	25051526	NSCT-4P1313 Socket
JL351b	25051096	NSCT-12P883 Holder

**DSP sub. PC board (NAETC-6516)**

ICs		
Q195	222740115RD	TC74HC4538AF, IC
Capacitors		
C197, C198	354782209	CE04W50V-22M Electric.
Diodes		
D195-D197	223233RD or 233234RD	1SS355 or 1SS352 Chip D.
Resistors		
R194	433121034RD	10k Ω ± 5%, 1/10W, Chip R.
R195, R196	433122724RD	2.7k Ω ± 5%, 1/10W, Chip R.
R197	433122214RD	220 Ω ± 5%, 1/10W, Chip R.
Others		
P195	72120120505	1007 #24 Jumper lead
P810a	25055888	NPLG-3P844 Plug

**Tone volume PC board (NAAF-6411)**

Transistors		
Q1468-Q1470	2215196	2SK364-BL
Diodes		
D1454-D1456	223163 or 223205	1SS133 or 1SS270A
Capacitors		
C1373, C1393	374721534	0.015 μF ± 5%, 50V, Plastic
Resistors		
R1451, R1453	5104386	N9RTL100KWT25F Volume

**NOTE:**

Replacement of the transistor of mark #, if necessary, must be made from the same beta group (HFE) as the original type.



# EXPLODED VIEW PARTS LIST

REF. No.	PART No.	Q'ty	DESCRIPTION	REF. No.	PART No.	Q'ty	DESCRIPTION
18	27100328C	1	Chassis	415	801433	14	3SMS8W. SW+14B(BC) Special screw
19	27190503A	2	KGLS-8RF Holder	416	27141681	1	Retainer (PWB)
20	27190428A	2	KGLS-10RF Holder	419	27141682A	1	Retainer (REAR)
21	27190772	2	KGLS-22RF Holder	420	27141683A	1	Retainer (FRONT)
22	27190062	1	KGLS-12S Holder	423	27160385A	1	Heat sink (SUB)
25	838130088	104	3TTB+8B Self tapping screw	500	28141282	4	Cushion Guide for FL
30	838150108	5	Self tapping screw 5TTB+10B	501	27191051	1	Holder(LED)
31	838430107	2	Self tapping screw 3TTB+10S(BC)	502	27190713	2	Holder UA-0
32	27111084	1	Front bracket	503	27191057	1	Holder (Video input jack)
36	830440089	4	4TTC+8C(BC) Self tapping screw	504	27150408	1	Shield plate
38	27300750	1	Bushing S-RELIEF #2271	D911	22380273	1	Diode RS804M
40	27141684A	1	Retainer (AC3)	E801	260208	16	Wire holder (CLAMPER)UL
44	27191016	2	Holder (NIFCO#2315)	E812	223024	6	Isolation sheet AC238
48	27270374	2	SPACER(Plastic washer $\Phi$ 9.5, t1.0)	E895*B1, B, C	880048	14	Plastic rivet P-3055B-8L
200*AH	27212027	1	Front panel	JL701	2047392512	1	Flexible flat cable WCFC7-392512
200*B1, B, C	27212039	1	Front panel	P901*AH	253244AHIT	1	AC cord AS-UC-6#18
201	28198858	1	Facet (POWER)	P901*B	253269AHIT	1	AC cord AS-BS
202	28191832	1	Clear plate (WINDOW)	P901*B1	253268HIT	1	AC cord AS-SAA
203	27287996	6	Guide (DUO)	P901*C	253245MAR	1	AC cord AS-CEE
204	27267998	2	Guide (RACKER)	P971	24502284	1	Fan KD2409PTB2
210	28184742	1	Cover (TOP)	Q1508	2212654 or	1	* 2SC3421-Y or
211	28325605	6	Button (DUO)	Q1513	2212653	1	* 2SC3421-0
212	28325607	1	Button (RACKER)	Q1514	2202833 or	1	* 2SA1962-0 or
213	838120068 or 838220068	16	Screw 2TTB+8B or 2TTB+6B(WI)	Q508	2202832	1	* 2SA1962-R
214	27215308	1	Decorative frame(INPUT)	Q513	2202843 or	1	* 2SC5242-0 or
215	28325608	4	Button (INPUT)	Q514	2202842	1	* 2SC5242-R
216	27191052	1	Holder (DECO)	Q563	2212654 or	1	* 2SC3421-Y or
217	838126068 or 83426068	9	ST screw 2.6TTB+6B or 2.6TTP+6B(BC) or 2.6TTS+6B(BC)	Q564	2212653	1	* 2SC3421-0
218	27267995	1	Guide power	Q508	2202833 or	1	* 2SA1962-0 or
219	28141235	1	Cushion	Q514	2202832	1	* 2SA1962-R
220	28325604	1	Button (POWER.BUTTON)	Q563	2202843 or	1	* 2SC5242-0 or
221	28325609	2	Knob (TONE.CONT.)	Q564	2202842	1	* 2SC5242-R
222	28325618	1	Knob (VOLUME)	Q508	2202833 or	1	* 2SA1962-0 or
223	27175320	4	Leg	Q508	2202832	1	* 2SA1962-R
224	28141332	4	Cushion for legs	Q508	2212654 or	1	* 2SC3421-Y or
225	28140546	1	Cushion (0.5x10x390) Top cover	Q508	2212653	1	* 2SC3421-0
226	831430088	4	3TTW+8B(BC) Self tapping screw				
227	28184743	1	Cover (VIDEO.IN)				
228	27215310	1	Decorative frame(Tone button)				
404*AH	27122506A	1	Rear panel				
404*B1, B, C	27122507A	1	Rear panel				
414	27160384	1	Heat sink (MAIN)				

REF. No.	PART No.	Q'ty	DESCRIPTION	REF. No.	PART No.	Q'ty	DESCRIPTION
Q613	2202833 or 2202832	1 *	2SA1962-0 or 2SA1962-R	PCB-1#B1, B,C	1A785584-1B	1	NAAR-6384-1B, Main circuit PC board ass'y
Q614	2202843 or 2202842	1 *	2SC5242-0 or 2SC5242-R	PCB-2#B1, B,C	1A785510-1B	1	MAAF-6410-1B, Tone control circuit PC board ass'y
Q663	2202843 or 2202842	1 *	2SC5242-0 or 2SC5242-R	PCB-3#B1, B,C	1A785511-1B	1	MAAF-6411-1B, Tone volume PC board ass'y
Q664	2202833 or 2202832	1 *	2SA1962-0 or 2SA1962-R	PCB-4#B1, B,C	1A785500-1B	1	MAETC-6400-1B, Surround speaker terminal PC board ass'y
RT1577, R1943	4000149	1	Thermistor PTH9048B222TS2F333	PCB-5#B1, B,C	1A785597-1B	1	MAAF-6397-1B, Front and center power amplifier PC board ass'y
T901#AH	2301360	1	Power transformer NPT-1351D	PCB-6#B1, B,C	1A785598-1B	1	MAAF-6398-1B, Surround power amplifier PC board ass'y
T901#B1, B,C	2301361	1	Power transformer NPT-1351P	PCB-7#B1, B,C	1A785506-1B	1	MAPS-6406-1B, Power supply circuit PC board ass'y
PCB-1#AH	1A785584-1A	1	NAAR-6384-1A, Main circuit PC board ass'y	PCB-10#B1, B,C	1A785504-1B	1	MAETC-6404-1B, Secondary circuit PC board ass'y
PCB-2#AH	1A785510-1A	1	MAAF-6410-1A, Tone control circuit PC board ass'y	PCB-11#B1, B,C	1A785508-1B	1	MAETC-6408-1B, Terminal PC board ass'y
PCB-3#AH	1A785511-1A	1	MAAF-6411-1A, Tone volume PC board ass'y	PCB-12#B1, B,C	1A785599-1B	1	MAETC-6399-1B, Speaker terminal PC board ass'y
PCB-4#AH	1A785500-1A	1	MAETC-6400-1A, Surround speaker terminal PC board ass'y	PCB-13#B1, B,C	1A785507-1B	1	MAETC-6407-1B, Power switch PC board ass'y
PCB-5#AH	1A785509-1A	1	MAAF-6409-1A, Pre. output terminal PC board ass'y	PCB-15#B1, B,C	1A785586-1B	1	MADIS-6386-1B, Display circuit PC board ass'y
PCB-6#AH	1A785597-1A	1	MAAF-6397-1A, Front and center power amplifier PC board ass'y	PCB-16#B1, B,C	1A785587-1B	1	MAAF-6387-1B, Volume circuit PC board ass'y
PCB-7#AH	1A785598-1A	1	MAAF-6398-1A, Surround power amplifier PC board ass'y	PCB-17#B1, B,C	1A785503-1B	1	MAETC-6403-1B, Headphone terminal PC board ass'y
PCB-8#AH	1A785505-1A	1	MAYD-6392-1A, S video circuit PC board ass'y	PCB-19#B1, B,C	1A785590-1B	1	MARF-6390-1B, Tuner circuit PC board ass'y
PCB-9#AH	1A785504-1A	1	MAETC-6404-1A, Secondary circuit PC board ass'y	PCB-20#B1, B,C	1A785591-1B	1	MAYD-6391-1B, Composite video circuit PC board ass'y
PCB-10#AH	1A785508-1A	1	MAETC-6408-1A, Terminal PC board ass'y	PCB-21#B1, B,C	1A785592-1B	1	MAYD-6392-1B, S video circuit PC board ass'y
PCB-11#AH	1A785506-1A	1	MAETC-6406-1A, Power supply circuit PC board ass'y	PCB-22#B1, B,C	1A785595-1B	1	MAETC-6395-1B, Digital input terminal PC board ass'y
PCB-12#AH	1A785599-1A	1	MAETC-6399-1A, Speaker terminal PC board ass'y	PCB-23#B1, B,C	1A785589-1B	1	MADG-6389-1, MAD link PC board ass'y
PCB-13#AH	1A785507-1A	1	MAETC-6407-1A, Power switch PC board ass'y	PCB-25#B1, B,C	1A785594-1B	1	MAETC-6394-1B, Front video terminal PC board ass'y
PCB-14#AH	1A785586-1A	1	MADIS-6386-1A, Display circuit PC board ass'y	PCB-26#B1, B,C	1A785593-1B	1	MAETC-6393-1B, Connector PC board ass'y
PCB-15#AH	1A785587-1A	1	MAAF-6387-1A, Volume circuit PC board ass'y	PCB-27#B1, B,C	1A785596-1B	1	MADG-6396-1B, DSP circuit PC board ass'y
PCB-16#AH	1A785584-1A	1	MAAF-6384-1A, Main circuit PC board ass'y	PCB-28#B1, B,C	1A785501-1B	1	MATEC-6401-1B, Thermal compensation PC board ass'y
PCB-17#AH	1A785510-1A	1	MAAF-6410-1A, Tone control circuit PC board ass'y	PCB-29#B1, B,C	1A785502-1B	1	MATEC-6402-1B, Thermal compensation PC board ass'y
PCB-18#AH	1A785511-1A	1	MAAF-6411-1A, Tone volume PC board ass'y	PCB-30#B1, B,C	1A785505-1B	1	MADG-6388-1B, AC-3 circuit PC board ass'y
PCB-19#AH	1A785500-1A	1	MAETC-6400-1A, Surround speaker terminal PC board ass'y	PCB-32#B1, B,C	1A785505-1B	1	MAETC-6405-1B, Regulator circuit PC board ass'y
PCB-20#AH	1A785509-1A	1	MAAF-6409-1A, Pre. output terminal PC board ass'y	PCB-33#B1, B,C	1A785585-1B	1	MAETC-6385-1B, PC board ass'y
PCB-21#AH	1A785597-1A	1	MAAF-6397-1A, Front and center power amplifier PC board ass'y	PCB-34#B1, B,C	1A785531-1B	1	MAETC-6431-1B, PC board ass'y
PCB-22#AH	1A785598-1A	1	MAAF-6398-1A, Surround power amplifier PC board ass'y	PCB-35#B1, B,C	1A785516-1B	1	MAETC-6516-1B, DSP sub PC board ass'y
PCB-23#AH	1A785506-1A	1	MAYD-6392-1A, S video circuit PC board ass'y				
PCB-24#AH	1A785504-1A	1	MAETC-6404-1A, Secondary circuit PC board ass'y				
PCB-25#AH	1A785508-1A	1	MAETC-6408-1A, Terminal PC board ass'y				
PCB-26#AH	1A785599-1A	1	MAETC-6399-1A, Speaker terminal PC board ass'y				
PCB-27#AH	1A785507-1A	1	MAETC-6407-1A, Power switch PC board ass'y				
PCB-28#AH	1A785586-1A	1	MADIS-6386-1A, Display circuit PC board ass'y				
PCB-29#AH	1A785587-1A	1	MAAF-6387-1A, Volume circuit PC board ass'y				
PCB-30#AH	1A785584-1A	1	MAAF-6384-1A, Main circuit PC board ass'y				
PCB-31#AH	1A785510-1A	1	MAAF-6410-1A, Tone control circuit PC board ass'y				
PCB-32#AH	1A785511-1A	1	MAAF-6411-1A, Tone volume PC board ass'y				
PCB-33#AH	1A785500-1A	1	MAETC-6400-1A, Surround speaker terminal PC board ass'y				
PCB-34#AH	1A785509-1A	1	MAAF-6409-1A, Pre. output terminal PC board ass'y				
PCB-35#AH	1A785597-1A	1	MAAF-6397-1A, Front and center power amplifier PC board ass'y				

NOTE: Replacement of the transistor of mark \*, if necessary, must be made from the same beta group (HFE) as the original type.

NOTE: THE COMPONENTS IDENTIFIED BY MARK  $\Delta$  ARE CRITICAL FOR RISK OF FIRE AND ELECTRIC SHOCK. REPLACE ONLY WITH RAPT NUMBER SPECIFIED.

NOTE: <AH>: U.S.A. and Canadian models only  
<B>: U.K. model only  
<B1>: Australian model only  
<C>: European model only



# PACKING DIAGRAM

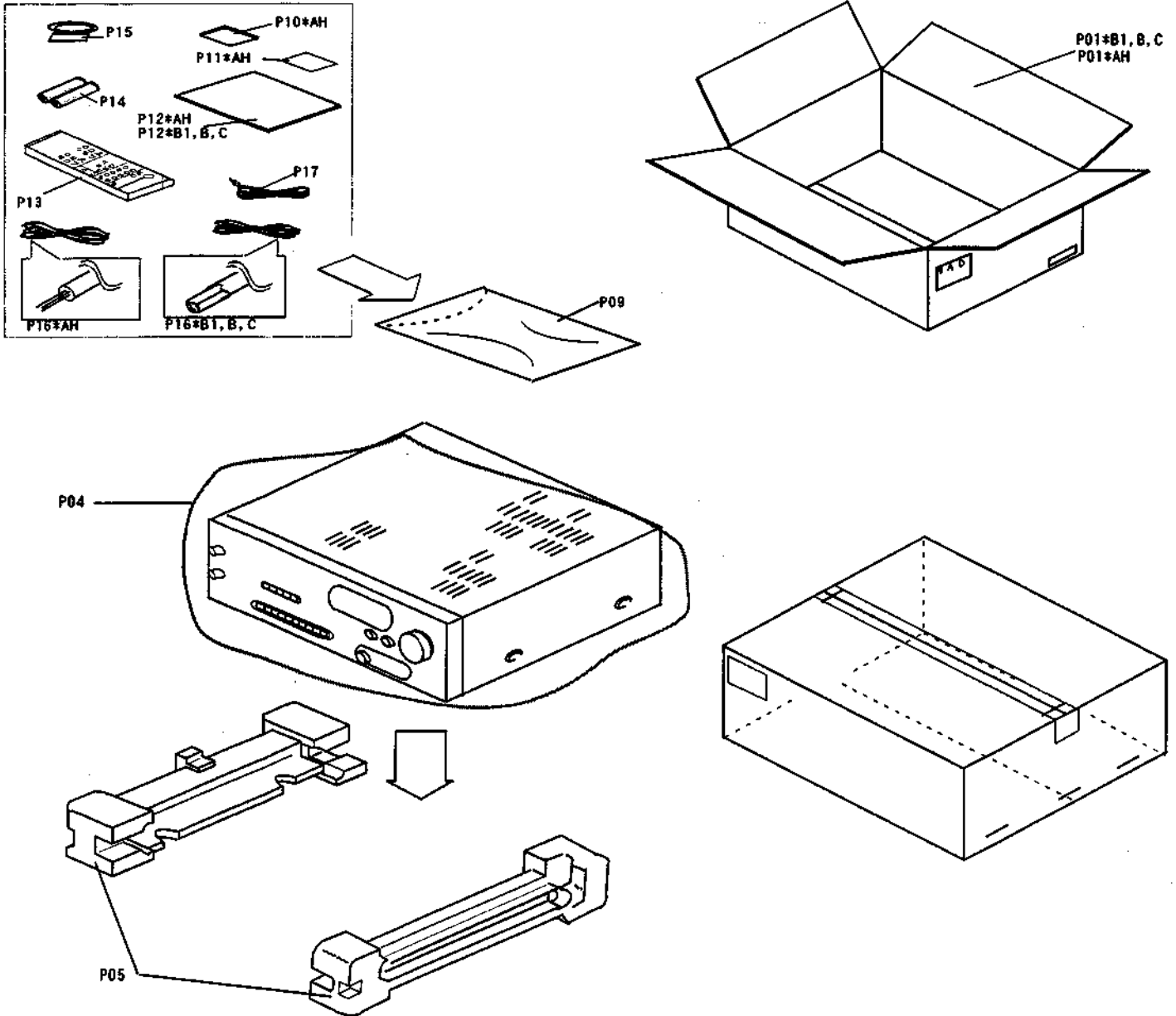

## Parts List

REF. No.	PART No.	Q'ty	DESCRIPTION	REF. No.	PART No.	Q'ty	DESCRIPTION
P01*AH	29053337	1	Carton	P10*AH	29355233	1	Instruction sheet E
P01*B1, B, C	29053354	1	Carton	P11*AH	29365078	1	Warranty card
P04	29100034-1A	1	Polystyrene bag (850*650)	P12*AH	29342621	1	Instruction manual U4EFGS
P05	29091855A	1	Pad ass'y T770	P12*B1, B, C	29342662	1	Instruction manual U4EIPSW
P09	29100097-1A	1	Polystyrene bag 350*250	P13	24140381R	1	Remote control T770
				P14	3010124	2	Battery UM-4
				P15	232140	1	AM antenna coil NMA-3057
				P16*AH	292111	1	FM antenna ass'y
				P16*B1, B, C	292112	1	FM antenna ass'y(connect type)
				P17	2010317	1	NAD link cable

NOTE: <AH>: U.S.A., Canadian model only  
 <B>: U.K. model only  
 <B1>: Australian model only  
 <C>: European model only

Proprietary information for servicing purposes only. The information herein may not be used commercially without the prior written agreement of NAD Electronics Ltd, London, England.

# Countermeasure for DVD noise

## 1. Purpose

To solve the POP-NOISE problem when using the Dolby Digital decoder (AC-3) function with DVD Player.

## 2. Modification object

Digital Signal Processor's Printed Wiring Board. [ NCDG-6396 ]

## 3. Contents of Modification Parts

- a. Micro Processor [ MPD78P014GC ] Part No. 22241265R3
- b. PWB Assembly [ NAETC-6516 ]
- c. Diode [ 1SS133 ] Part No. 223163
- d. Wire Black, 120mm (P195 to anode of D135)
- Wire Red, 120mm (P196 to J1715)

## 4. Procedure

Please install the countermeasure parts with following procedure.

- a. Remove the IC (Q791 : MPD78014FGC) carefully. \*De-soldering tool will be necessary.
- b. Solder the IC (Q791 : MPD78P014GC) carefully.
- c. Remove the Jumper wire ("J1729" : Pitch = 20mm).
- d. To insert the additional PWB (NCETC-6516), remove solder & open the hole of "P810b"
- e. Insert the additional PWB (NCETC-6516) to the "P810b" and solder.
- f. Insert the DIODE ("D135" : 1SS133) to the hole of "J1729" as drawing.
- g. Insert the wire lead (P195 : Black / 120mm) with ANODE of D135 together and solder.
- h. Solder the wire lead (P196 : Red / 120mm) together with "J1715" on component side.

## 5. Application

- <AH> model: Serial number 087700001 ~ 087701000 (1000 sets)
- <C> model : Serial number 087701001 ~ 087701400 (400 sets)

