

SERVICE MANUAL

L55
DVD/VIDEO CD/CD
PLAYER

© NAD 2001

NAD ELECTRONICS INTERNATIONAL
LONDON

L55
DVD/VIDEO CD/CD
PLAYER

SERVICE MANUAL

L55

DVD/VIDEO CD/CD
PLAYER



SECTION 1

SUMMARY

CONTENTS

PRODUCT SAFETY SERVICING GUIDELINES FOR VIDEO PRODUCTS	1-3
SERVICING PRECAUTIONS	1-4
•General Servicing Precautions	
•Insulation Checking Prodedure	
•Electrostatically Sensitive Devices	
SPECIFICATIONS	1-5
LOCATION OF CUSTOMER CONTROLS	1-6
EXPLODED VIEWS	1-9

PRODUCT SAFETY SERVICING GUIDELINES FOR VIDEO PRODUCTS

CAUTION : DO NOT ATTEMPT TO MODIFY THIS PRODUCT IN ANY WAY. NEVER PERFORM CUSTOMIZED INSTALLATIONS WITHOUT MANUFACTURER'S APPROVAL. UNAUTHORIZED MODIFICATIONS WILL NOT ONLY VOID THE WARRANTY, BUT MAY LEAD TO YOUR BEING LIABLE FOR ANY RESULTING PROPERTY DAMAGE OR USER INJURY.

SERVICE WORK SHOULD BE PERFORMED ONLY AFTER YOU ARE THOROUGHLY FAMILIAR WITH ALL OF THE FOLLOWING SAFETY CHECKS AND SERVICING GUIDELINES. TO DO OTHERWISE, INCREASES THE RISK OF POTENTIAL HAZARDS AND INJURY TO THE USER.

WHILE SERVICING, USE AN ISOLATION TRANSFORMER FOR PROTECTION FROM A.C. LINE SHOCK.

SAFETY CHECKS

AFTER THE ORIGINAL SERVICE PROBLEM HAS BEEN CORRECTED. A CHECK SHOULD BE MADE OF THE FOLLOWING.

SUBJECT : FIRE & SHOCK HAZARD

1. BE SURE THAT ALL COMPONENTS ARE POSITIONED IN SUCH A WAY AS TO AVOID POSSIBILITY OF ADJACENT COMPONENT SHORTS. THIS IS ESPECIALLY IMPORTANT ON THOSE MODULES WHICH ARE TRANSPORTED TO AND FROM THE REPAIR SHOP.
2. NEVER RELEASE A REPAIR UNLESS ALL PROTECTIVE DEVICES SUCH AS INSULATORS, BARRIERS, COVERS, SHIELDS, STRAIN RELIEFS, POWER SUPPLY CORDS, AND OTHER HARDWARE HAVE BEEN REINSTALLED PER ORIGINAL DESIGN. BE SURE THAT THE SAFETY PURPOSE OF THE POLARIZED LINE PLUG HAS NOT BEEN DEFEATED.
3. SOLDERING MUST BE INSPECTED TO DISCOVER POSSIBLE COLD SOLDER JOINTS, SOLDER SPLASHES OR SHARP SOLDER POINTS. BE CERTAIN TO REMOVE ALL LOOSE FOREIGN PARTICLES.
4. CHECK FOR PHYSICAL EVIDENCE OF DAMAGE OR DETERIORATION TO PARTS AND COMPONENTS. FOR FRAYED LEADS, DAMAGED INSULATION (INCLUDING A.C. CORD). AND REPLACE IF NECESSARY FOLLOW ORIGINAL LAYOUT, LEAD LENGTH AND DRESS.
5. NO LEAD OR COMPONENT SHOULD TOUCH A RECEIVING TUBE OR A RESISTOR RATED AT 1 WATT OR MORE. LEAD TENSION AROUND PROTRUDING METAL SURFACES MUST BE AVOIDED.
6. ALL CRITICAL COMPONENTS SUCH AS FUSES, FLAMEPROOF RESISTORS, CAPACITORS, ETC. MUST BE REPLACED WITH EXACT FACTORY TYPES, DO NOT USE REPLACEMENT COMPONENTS OTHER THAN THOSE SPECIFIED OR MAKE UNRECOMMENDED CIRCUIT MODIFICATIONS.
7. AFTER RE-ASSEMBLY OF THE SET ALWAYS PERFORM AN A.C. LEAKAGE TEST ON ALL EXPOSED METALLIC PARTS OF THE CABINET, (THE CHANNEL SELECTOR KNOB, ANTENNA TERMINALS. HANDLE AND SCREWS) TO BE SURE THE SET IS SAFETY TO OPERATE WITHOUT DANGER OF ELECTRICAL SHOCK. DO NOT USE A LINE ISOLATION TRANSFORMER DURING THIS TEST USE AN A.C. VOLTMETER, HAVING 5000 OHMS PER VOLT OR MORE SENSITIVITY, IN THE FOLLOWING MANNER; CONNECT A 1500 OHM 10 WATT RESISTOR, PARALLELED BY A .15 MFD, 150.V A.C TYPE CAPACITOR BETWEEN A KNOWN GOOD EARTH GROUND (WATER PIPE, CONDUIT, ETC.) AND THE EXPOSED METALLIC PARTS, ONE AT A TIME. MEASURE THE A.C. VOLTAGE ACROSS THE COMBINATION OF 1500 OHM RESISTOR AND .15 MFD CAPACITOR. REVERSE THE A.C. PLUG AND REPEAT A.C. VOLTAGE MEASUREMENTS FOR EACH EXPOSED METALLIC PART.

VOLTAGE MEASURE MUST NOT EXCEED 75 VOLTS R.M.S. THIS CORRESPONDS TO 0.5 MILLIAMPS A.C ANY VALUE EXCEEDING THIS LIMIT CONSTITUTES A POTENTIAL SHOCK HAZARD AND MUST BE CORRECTED IMMEDIATELY.

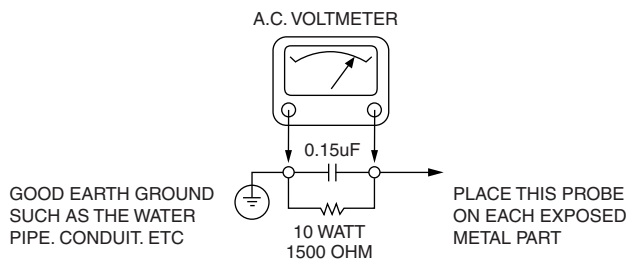

SUBJECT : GRAPHIC SYMBOLS



THE LIGHTNING FLASH WITH ARROWHEAD SYMBOL, WITHIN AN EQUILATERAL TRIANGLE, IS INTENDED TO ALERT THE USER TO THE PRESENCE OF UNINSULATED "DANGEROUS VOLTAGE" WITHIN THE PRODUCT'S ENCLOSURE THAT MAY BE OF SUFFICIENT MAGNITUDE TO CONSTITUTE A RISK OF ELECTRIC SHOCK.



THE EXCLAMATION POINT WITHIN AN EQUILATERAL TRIANGLE IS INTENDED TO ALERT THE USER TO THE PRESENCE OF IMPORTANT OPERATING AND MAINTENANCE (SERVICING) INSTRUCTIONS IN THE LITERATURE ACCOMPANYING THE APPLIANCE.

SUBJECT : TIPS ON PROPER INSTALLATION

1. NEVER INSTALL ANY PRODUCT IN A CLOSED-IN RECESS, CUBBYHOLE OR CLOSELY FITTING SHELF SPACE. OVER OR CLOSE TO HEAT DUCT, OR IN THE PATH OF HEATED AIR FLOW.
2. AVOID CONDITIONS OF HIGH HUMIDITY SUCH AS: OUTDOOR PATIO INSTALLATIONS WHERE DEW IS A FACTOR, NEAR STEAM RADIATORS WHERE STEAM LEAKAGE IS A FACTOR, ETC.
3. AVOID PLACEMENT WHERE DRAPERIES MAY OBSTRUCT REAR VENTING. THE CUSTOMER SHOULD ALSO AVOID THE USE OF DECORATIVE SCARVES OR OTHER COVERINGS WHICH MIGHT OBSTRUCT VENTILATION.
4. WALL AND SHELF MOUNTED INSTALLATIONS USING A COMMERCIAL MOUNTING KIT MUST FOLLOW THE FACTORY APPROVED MOUNTING INSTRUCTIONS A PRODUCT MOUNTED TO A SHELF OR PLATFORM MUST RETAIN ITS ORIGINAL FEET (OR THE EQUIVALENT THICKNESS IN SPACERS) TO PROVIDE ADEQUATE AIR FLOW ACROSS THE BOTTOM, BOLTS OR SCREWS USED FOR FASTENERS MUST NOT TOUCH ANY PARTS OR WIRING. PERFORM LEAKAGE TEST ON CUSTOMIZED INSTALLATIONS.
5. CAUTION CUSTOMERS AGAINST THE MOUNTING OF A PRODUCT ON SLOPING SHELF OR A TILTED POSITION, UNLESS THE PRODUCT IS PROPERLY SECURED.
6. A PRODUCT ON A ROLL-ABOUT CART SHOULD BE STABLE ON ITS MOUNTING TO THE CART. CAUTION THE CUSTOMER ON THE HAZARDS OF TRYING TO ROLL A CART WITH SMALL CASTERS ACROSS THRESHOLDS OR DEEP PILE CARPETS.
7. CAUTION CUSTOMERS AGAINST THE USE OF A CART OR STAND WHICH HAS NOT BEEN LISTED BY UNDERWRITERS LABORATORIES, INC. FOR USE WITH THEIR SPECIFIC MODEL OF TELEVISION RECEIVER OR GENERICALLY APPROVED FOR USE WITH T.V.'S OF THE SAME OR LARGER SCREEN SIZE.
8. CAUTION CUSTOMERS AGAINST THE USE OF EXTENSION CORDS, EXPLAIN THAT A FOREST OF EXTENSIONS SPROUTING FROM A SINGLE OUTLET CAN LEAD TO DISASTROUS CONSEQUENCES TO HOME AND FAMILY.

SERVICING PRECAUTIONS

CAUTION : Before servicing the DVD player covered by this service data and its supplements and addends, read and follow the *SAFETY PRECAUTIONS*. **NOTE :** if unforeseen circumstances create conflict between the following servicing precautions and any of the safety precautions in this publication, always follow the safety precautions.

Remember Safety First:

General Servicing Precautions

1. Always unplug the DVD player's AC power cord from the AC power source before:
 - (1) Removing or reinstalling any component, circuit board, module, or any other assembly.
 - (2) Disconnecting or reconnecting any internal electrical plug or other electrical connection.
 - (3) Connecting a test substitute in parallel with an electrolytic capacitor.

Caution : A wrong part substitution or incorrect polarity installation of electrolytic capacitors may result in an explosion hazard.
2. Do not spray chemicals on or near this DVD player or any of its assemblies.
3. Unless specified otherwise in this service data, clean electrical contacts by applying an appropriate contact cleaning solution to the contacts with a pipe cleaner, cottontipped swab, or comparable soft applicator.
Unless specified otherwise in this service data, lubrication of contacts is not required.
4. Do not defeat any plug/socket B+ voltage interlocks with which instruments covered by this service manual might be equipped.
5. Do not apply AC power to this DVD player and/or any of its electrical assemblies unless all solid-state device heat sinks are correctly installed.
6. Always connect test instrument ground lead to the appropriate ground before connecting the test instrument positive lead. Always remove the test instrument ground lead last.

Insulation Checking Procedure

Disconnect the attachment plug from the AC outlet and turn the power on. Connect an insulation resistance meter(500V) to the blades of the attachment plug. The insulation resistance between each blade of the attachment plug and accessible conductive parts (Note 1) should be more than 1M-ohm.

Note 1 : Accessible Conductive Parts including Metal panels, Input terminals, Earphone jacks, etc.

Electrostatically Sensitive (ES) Devices

Some semiconductor (solid state) devices can be damaged easily by static electricity. Such components commonly are called Electrostatically Sensitive (ES) Devices. Examples of typical Es devices are integrated circuits and some field effect transistors and semiconductor chip components.

The following techniques should be used to help reduce the incidence of component damage caused by static electricity.

1. Immediately before handling any semiconductor component or semiconductor-equipped assembly, drain off any electrostatic charge on your body by touching a known earth ground. Alternatively, obtain and wear a commercially available discharging wrist strap device, which should be removed for potential shock reasons prior to applying power to the unit under test.
2. After removing an electrical assembly equipped with ES devices, place the assembly on a conductive surface such as aluminum foil, to prevent electrostatic charge buildup or exposure of the assembly.
3. Use only a grounded-tip soldering iron to solder or unsolder ES devices.
4. Use only an antistatic solder removal device. Some solder removal devices not classified a "anti-static" can generate electrical charges sufficient to damage ES devices.
5. Do not use freonpropelled chemicals. These can generate electrical charge sufficient to damage ES devices.
6. Do not remove a replacement ES device from its protective package until immediately before you are ready to install it. (Most replacement ES devices are packaged with leads electrically shorted together by conductive foam, aluminum foil, or comparable conductive material).
7. Immediately before removing the protective material from the leads of a replacement ES device, touch the protective material to the chassis or circuit assembly into which the device will be installed.

Caution : Be sure no power is applied to the chassis or circuit, and observe all other safety precautions.

8. Minimize bodily motions when handling unpackaged replacement ES devices. (Normally harmless motion such as the brushing together of your clothes fabric or the lifting of your foot from a carpeted floor can generate static electricity sufficient to damage an ES device.)

SPECIFICATIONS

DVD player/Outputs/Supplied Accessories

[DVD player]	Power supply	AC 230V / 50 Hz (EUROPE), AC 110V/60Hz (USA / CANADA)
	Power consumption	15 W
	Mass	3.3 kg
	External dimensions (W X H X D)	285 x 103x 291 mm
	Signal system	PAL (EUR) , NTSC (USA / CANADA)
	Laser	Semiconductor laser, wavelength 650 nm
	Frequency range (audio)	4 Hz to 20 kHz
	Signal-to-noise ratio (audio)	More than 100 dB (EIAJ)
	Dynamic range (audio)	More than 95 dB (EIAJ)
	Harmonic distortion (audio)	0.008 %
	Wow and flutter	Below measurable level (less than + 0.001 % (W.PEAK)) (EIAJ)
	Operating conditions	Temperature: 41°F to 95°F, Operation status: Horizontal
[Outputs]	Video output	1.0 V (p-p), 75 Ω , negative sync., RCA jack x 1
	S-video output	(Y) 1.0 V (p-p), 75 Ω , negative sync., Mini DIN 4-pin x 1 (C) 0.286 V (p-p), 75 Ω ,
	SCART video output	CVBS 1.0 V (p-p), 75 Ω , negative sync., RCA jack x 1 (RGB) 0.63 V (p-p), 75 Ω
	Audio output (digital audio)	0.5 V (p-p), 75 Ω , RCA jack x 1
	Audio output (optical audio)	Optical connector x 1
	Audio output (analog audio)	2.0 Vrms(1 KHz, 0 dB), 330 Ω , RCA jack (L, R) x 1
[Supplied Accessories]	<ul style="list-style-type: none"> ● Video cable. 1 ● Audio cable. 1 	

* Designs and specifications are subject to change without notice.

LOCATION OF CUSTOMER CONTROLS

Front Panel

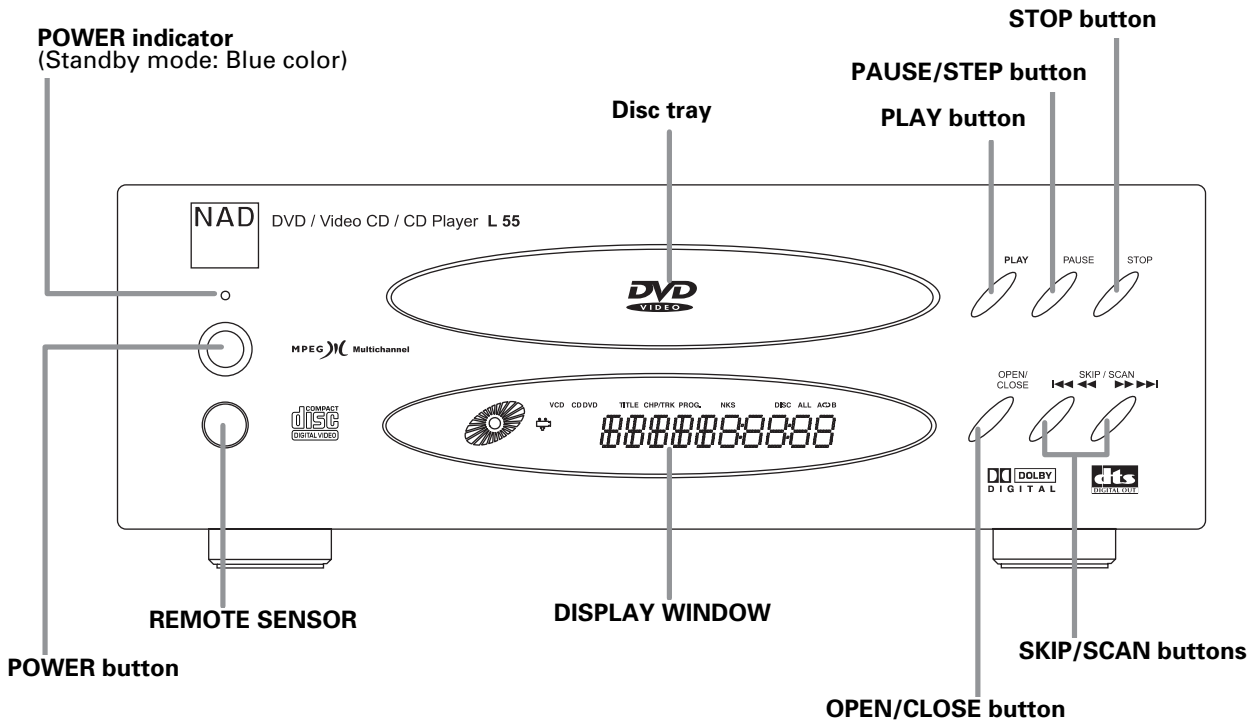

Display Window

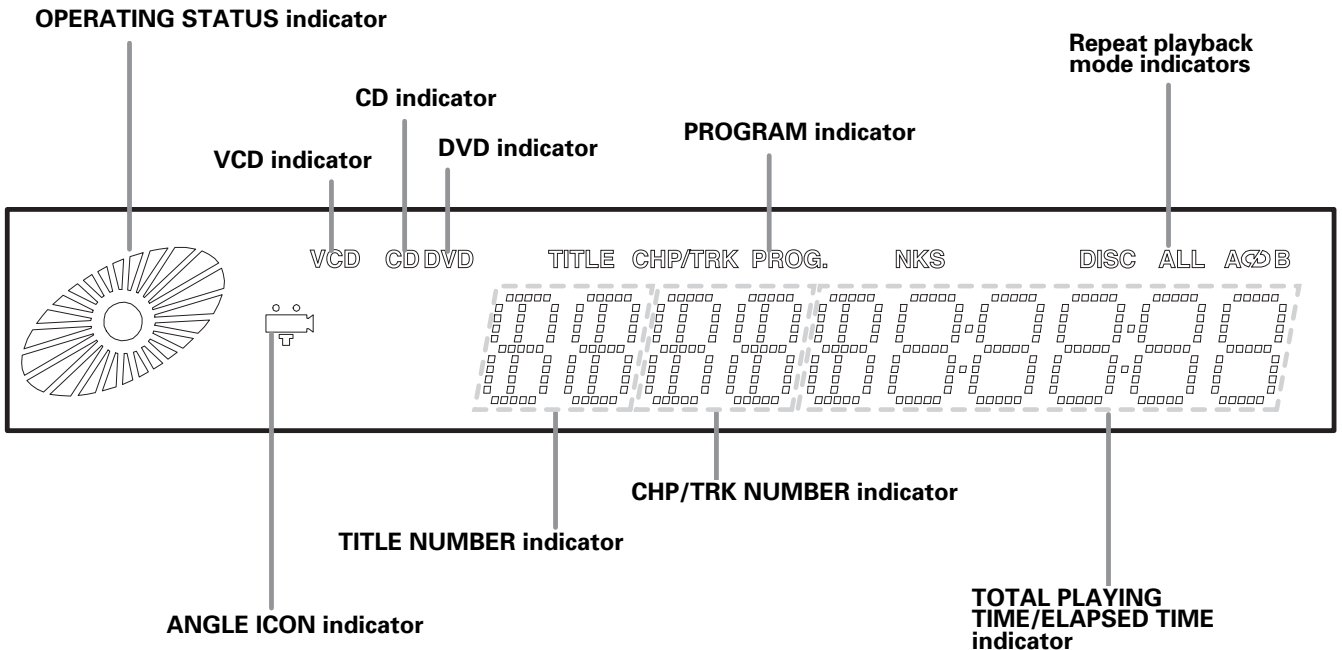

Rear Panel

*EUR VERSION

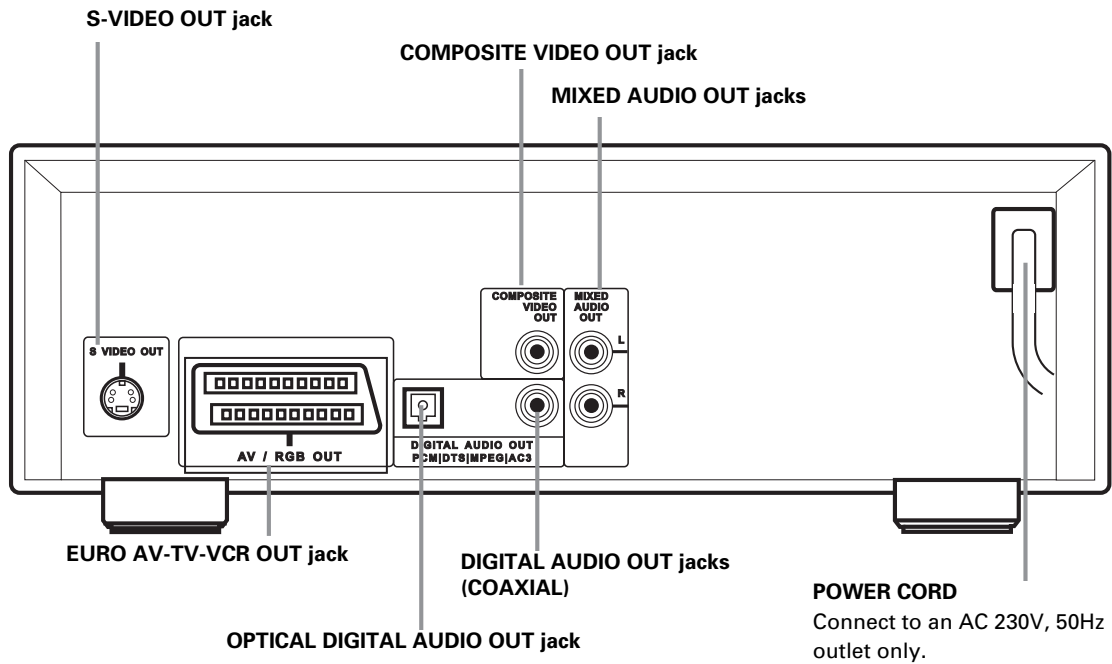

*USA/CANADA VERSION

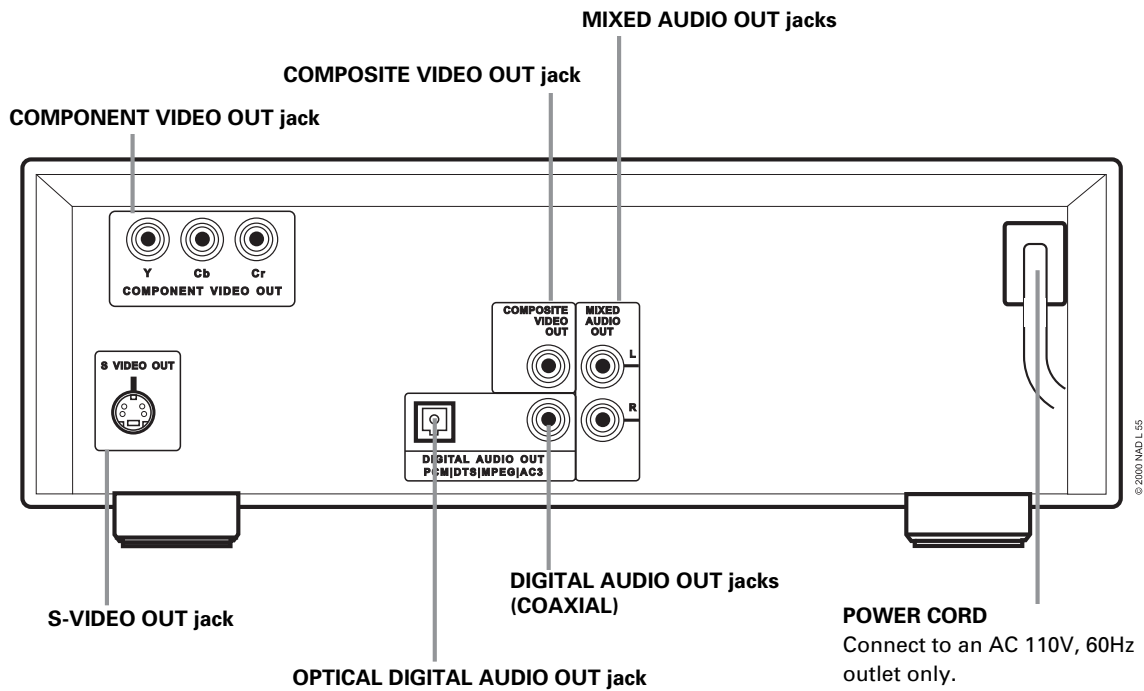

REMOTE CONTROL

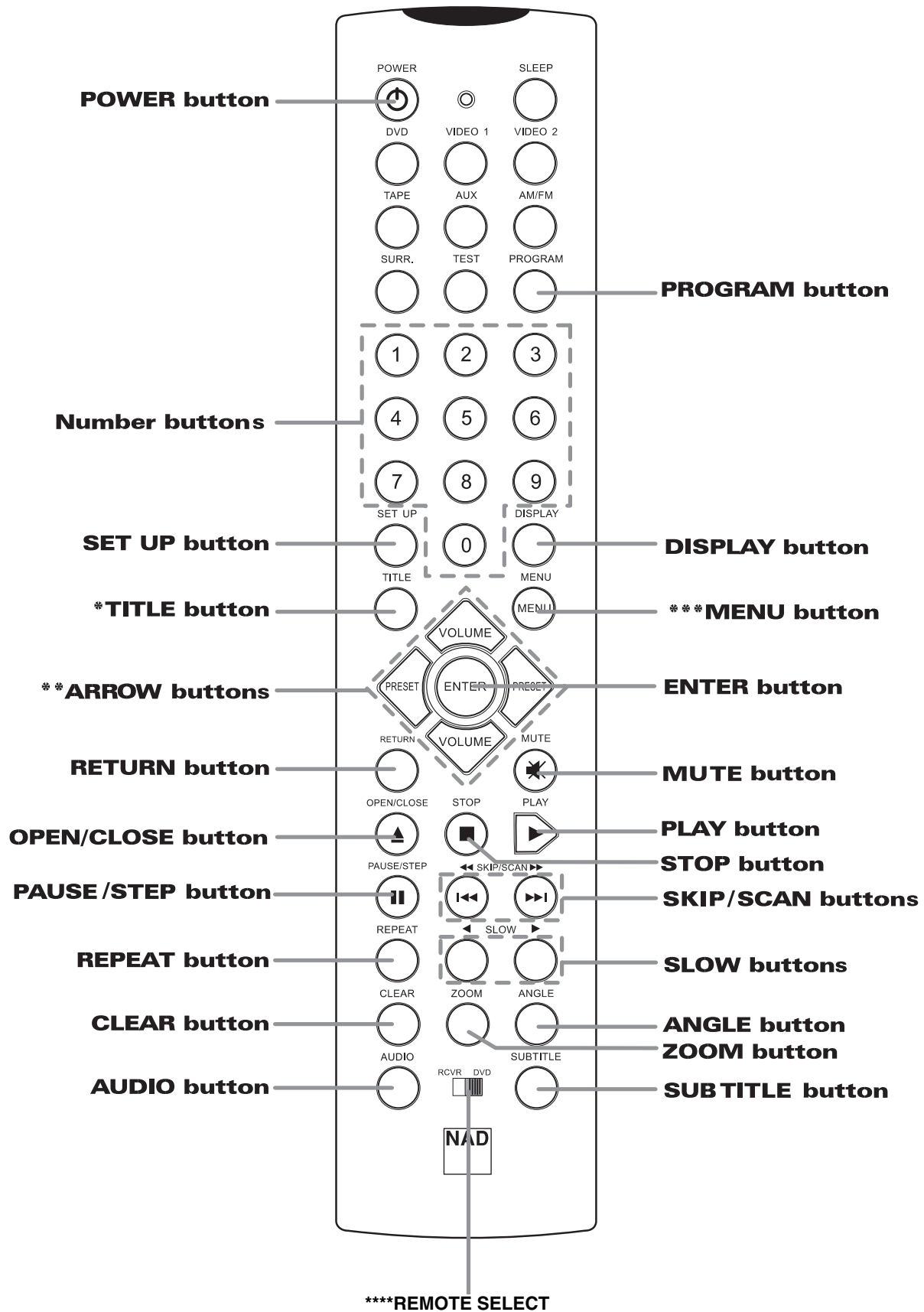

EXPLODED VIEW

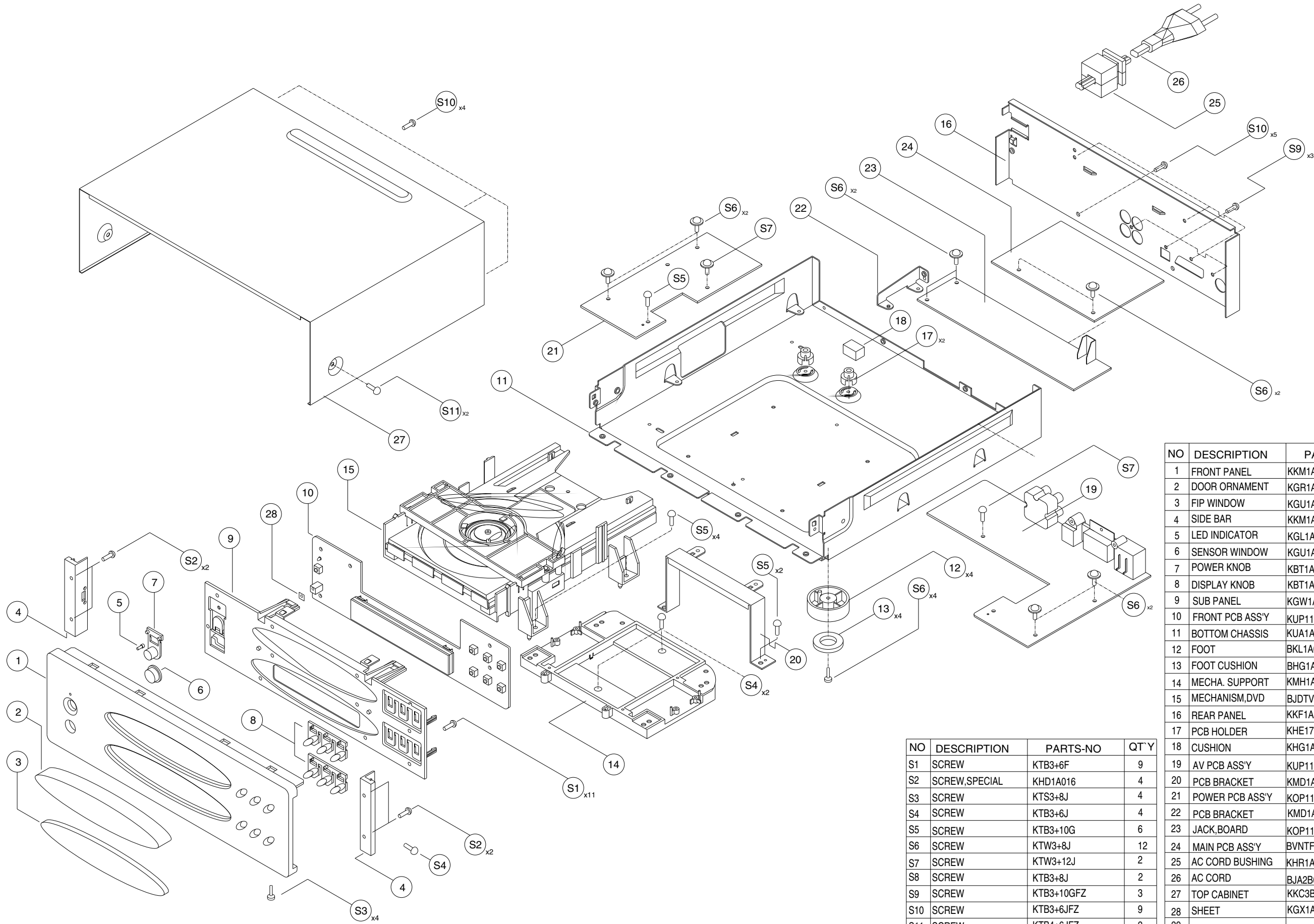

NO	DESCRIPTION	PARTS-NO	QTY
1	FRONT PANEL	KKM1A106ZC26	1
2	DOOR ORNAMENT	KGR1A214M7ZK102	1
3	FIP WINDOW	KGU1A244A8	1
4	SIDE BAR	KKM1A051C26	2
5	LED INDICATOR	KGL1A188	0.17
6	SENSOR WINDOW	KGU1A245A10	1
7	POWER KNOB	KBT1A746M7K102	1
8	DISPLAY KNOB	KBT1A745M7K102	2
9	SUB PANEL	KGW1A298	1
10	FRONT PCB ASS'Y	KUP11408C	1
11	BOTTOM CHASSIS	KUA1A189	1
12	FOOT	BKL1A060	4
13	FOOT CUSHION	BHG1A171	4
14	MECHA. SUPPORT	KMH1A113	1
15	MECHANISM,DVD	BJDTVM502/1	1
16	REAR PANEL	KKF1A210Z	1
17	PCB HOLDER	KHE170	2
18	CUSHION	KHG1A104	1
19	AV PCB ASS'Y	KUP11390Z	1
20	PCB BRACKET	KMD1A413	1
21	POWER PCB ASS'Y	KOP11401CSMPS	1
22	PCB BRACKET	KMD1A420	1
23	JACK,BOARD	KOP11408B	1
24	MAIN PCB ASS'Y	BVNTFCEIE311A	1
25	AC CORD BUSHING	KHR1A028	1
26	AC CORD	BJA2B043Z	1
27	TOP CABINET	KKC3B076S33	1
28	SHEET	KGX1A304	1
29			
S1	SCREW	KTB3+6F	9
S2	SCREW,SPECIAL	KHD1A016	4
S3	SCREW	KTS3+8J	4
S4	SCREW	KTB3+6J	4
S5	SCREW	KTB3+10G	6
S6	SCREW	KTW3+8J	12
S7	SCREW	KTW3+12J	2
S8	SCREW	KTB3+8J	2
S9	SCREW	KTB3+10GFZ	3
S10	SCREW	KTB3+6JFZ	9
S11	SCREW	KTB4+6JFZ	2

SECTION 2 ELECTRICAL CONTENTS

ELECTRICAL TROUBLESHOOTING GUIDE.....	2-2
1. Power (SMPS) Circuit.....	2-2
2. μ -com Circuit.....	2-3
3. MPEG Circuit.....	2-6
4. Front Circuit (Digitron & Key)	2-7
5. RF/Servo Circuit	2-8
BLOCK DIAGRAMS	2-12
1. Overall Block Diagram	2-12
2. Power (SMPS) Block Diagram.....	2-13
3. RF/CD DSP/DVD DSP/DVD servo Block Diagram	2-14
4. Audio Block Diagram	2-15
5. MPEG Block Diagram.....	2-16
6. μ -COM Block Diagram.....	2-17
CIRCUIT DIAGRAMS	2-18
1. Power (SMPS) Circuit Diagram	2-18
2. DVD DSP Circuit Diagram	2-20
3. Drive & RF Circuit Diagram	2-22
4. MPEG Circuit Diagram	2-24
4-1. WAVEFORMS	2-26
5. Audio DM & 5.1CH Circuit Diagram	2-28
6. μ -COM/Expander	2-30
7. DIGITRON & Key Circuit Diagram	2-32
8. Jack Circuit Diagram	2-34
PRINTED CIRCUIT DIAGRAMS	2-36
1. MAIN P.C.BOARD	2-36
2. POWER P.C.BOARD.....	2-38
3. AV P.C.BOARD	2-40
4. FRONT P.C.BOARD	2-42

ELECTRICAL TROUBLESHOOTING GUIDE

1. POWER (SMPS) Circuit

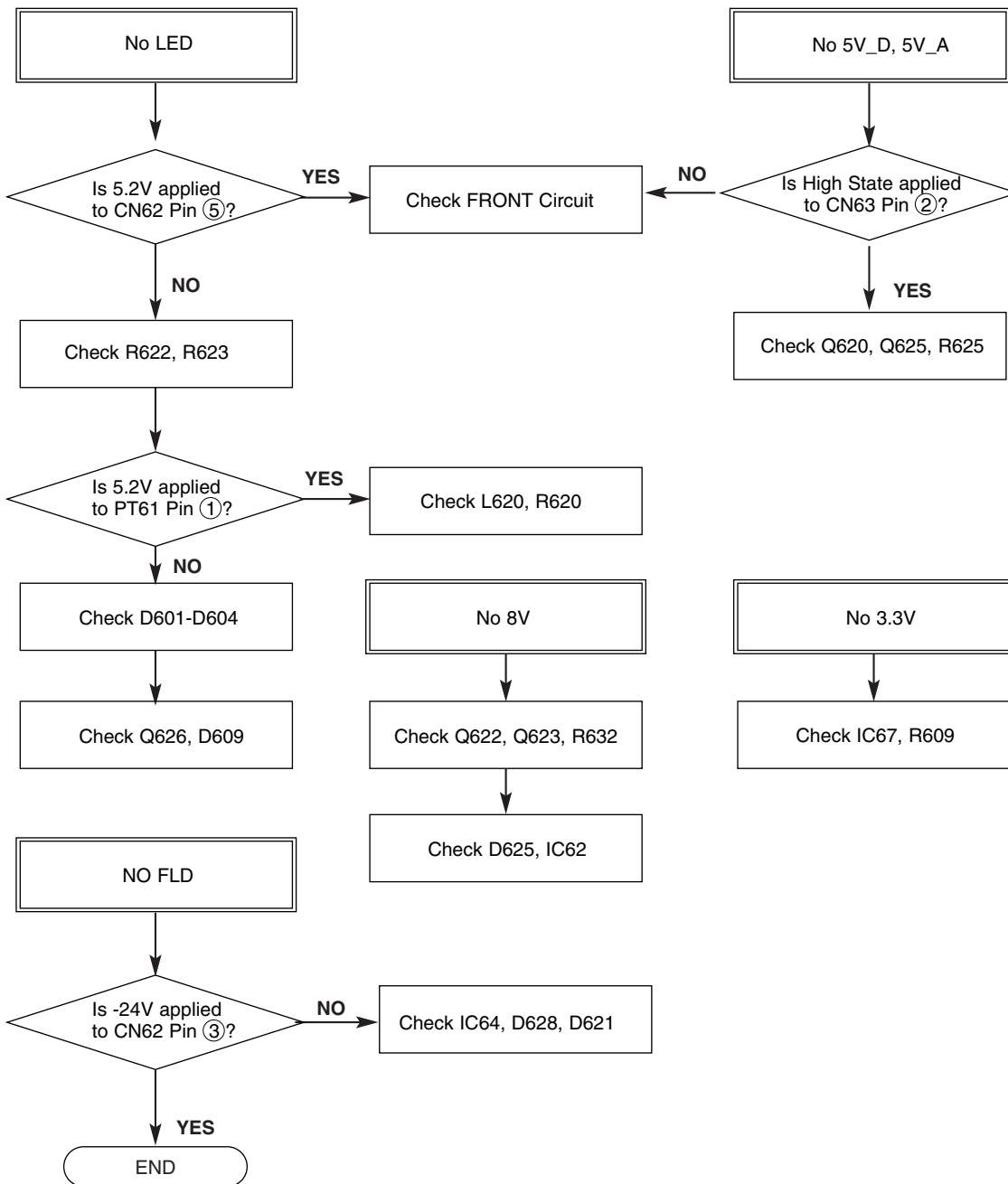

2. u-COM Circuit

A. NO Power

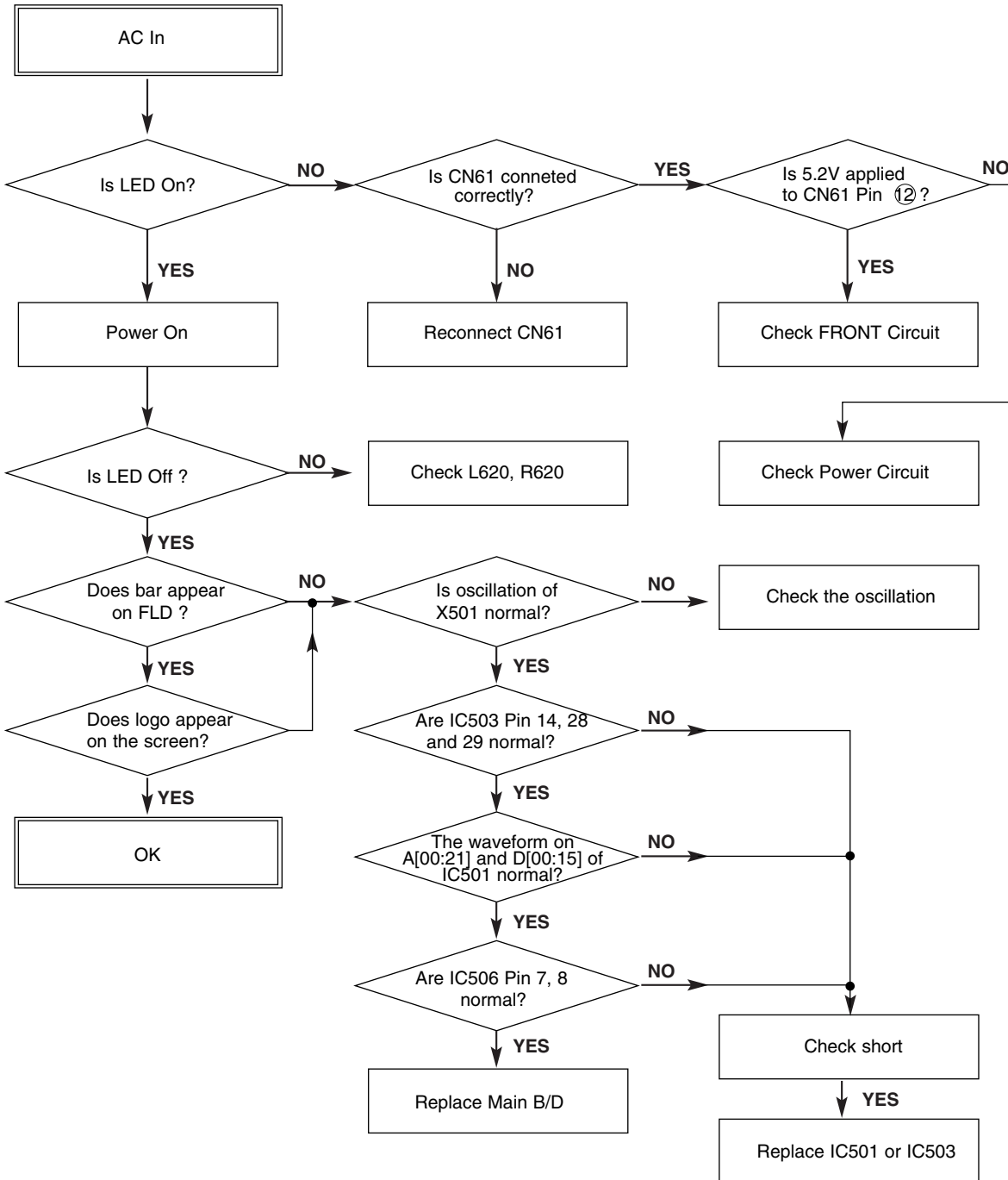

B. Audio abnormal

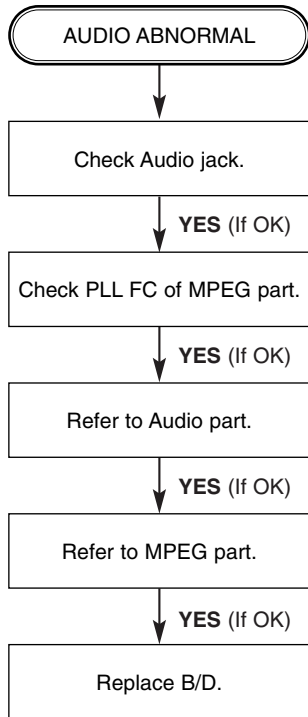

C. Video abnormal

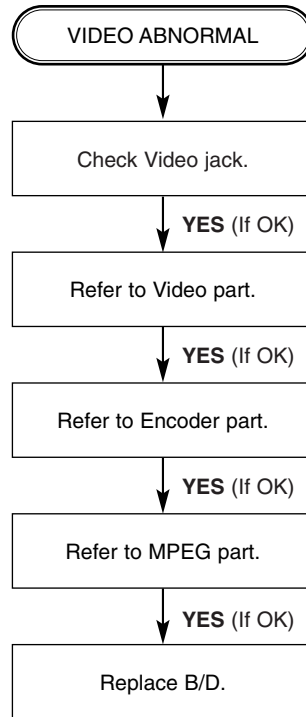

D. Open/Close abnormal

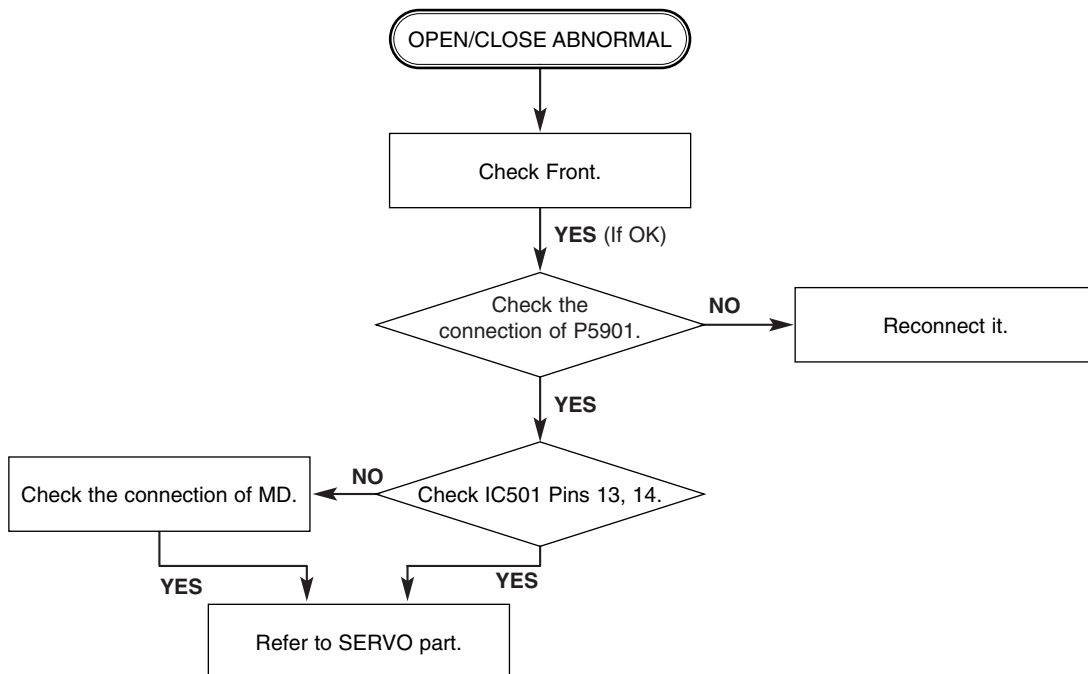

E. Picture abnormal

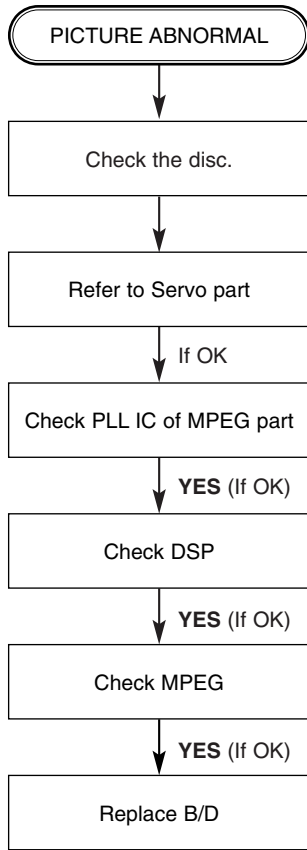

F. Disc Error

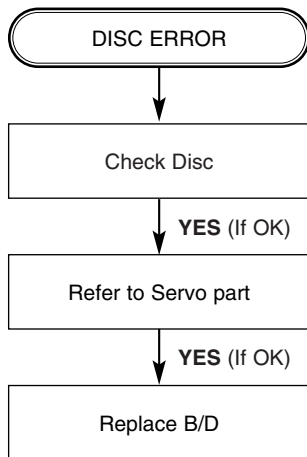

3. MPEG Circuit

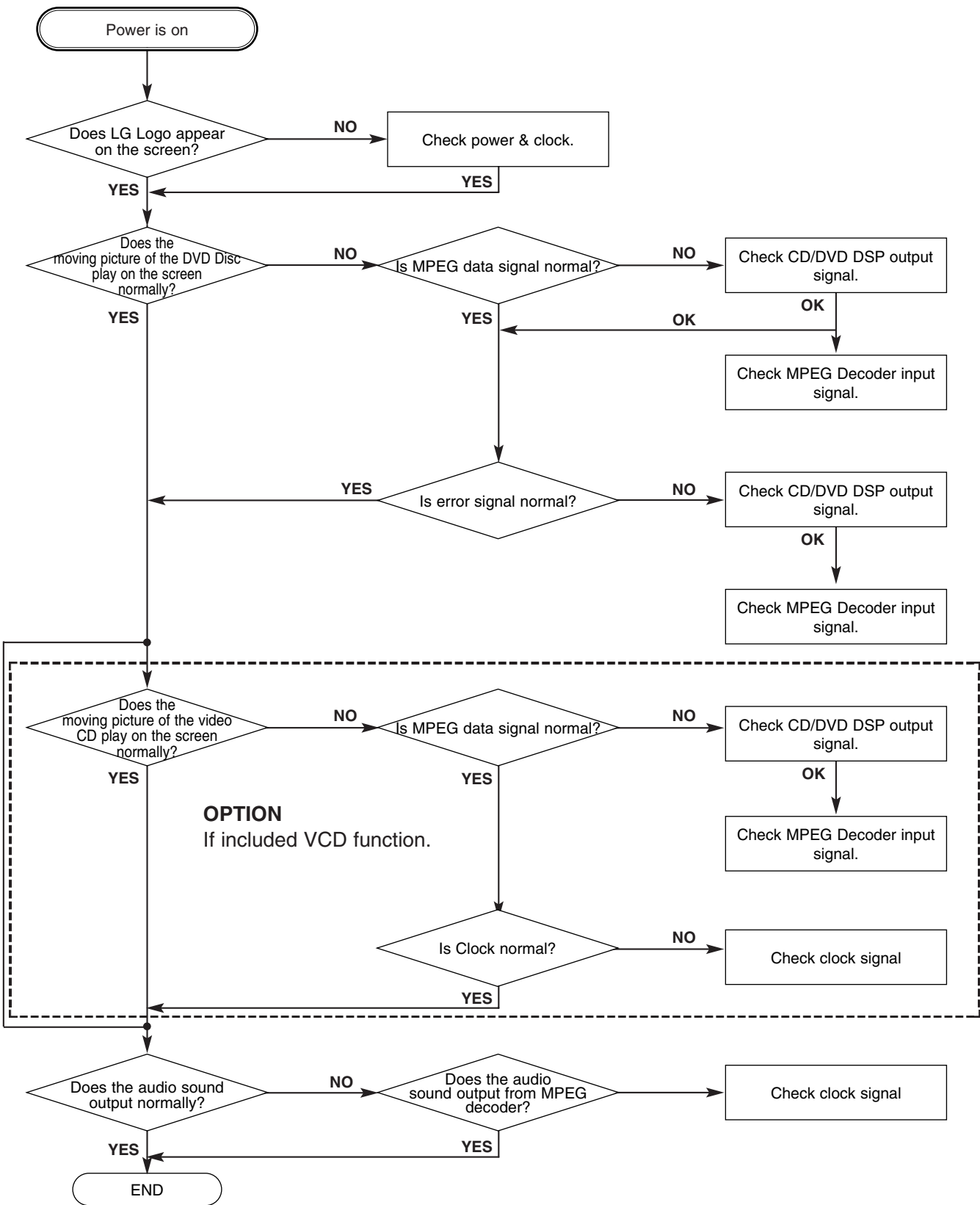

4. Front Circuit (Digitron & Key)

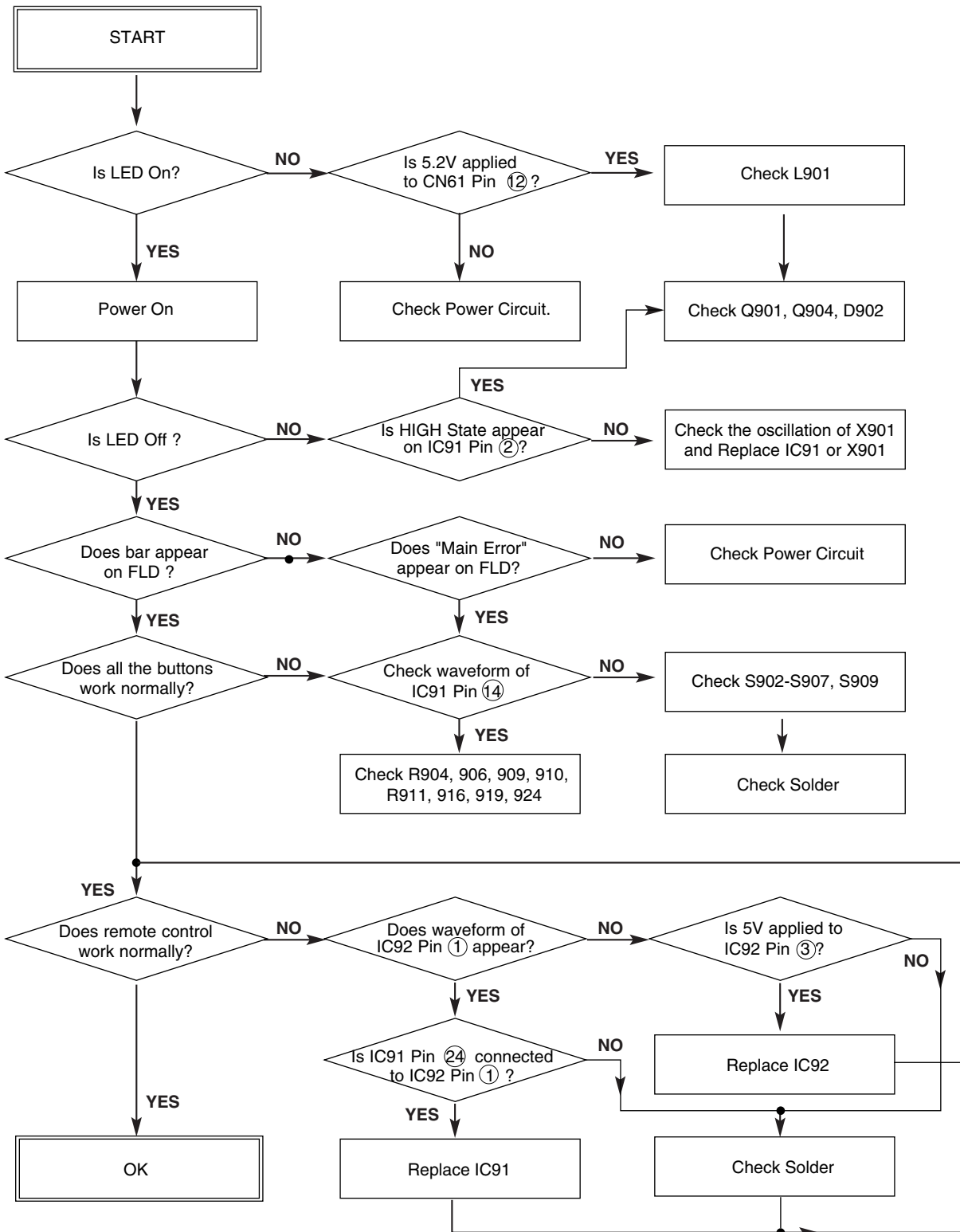

5. RF/Servo Circuit

A.

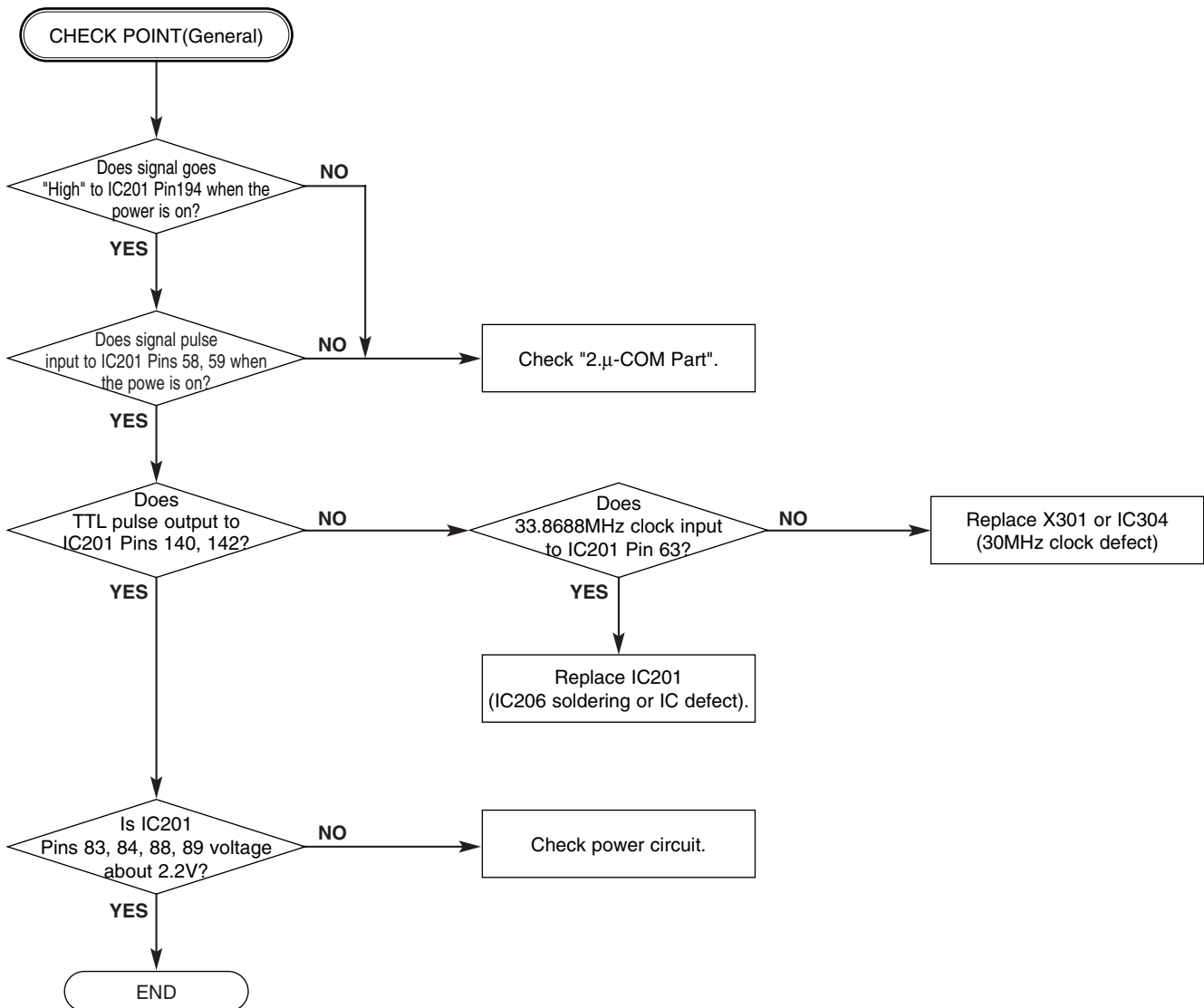

B.

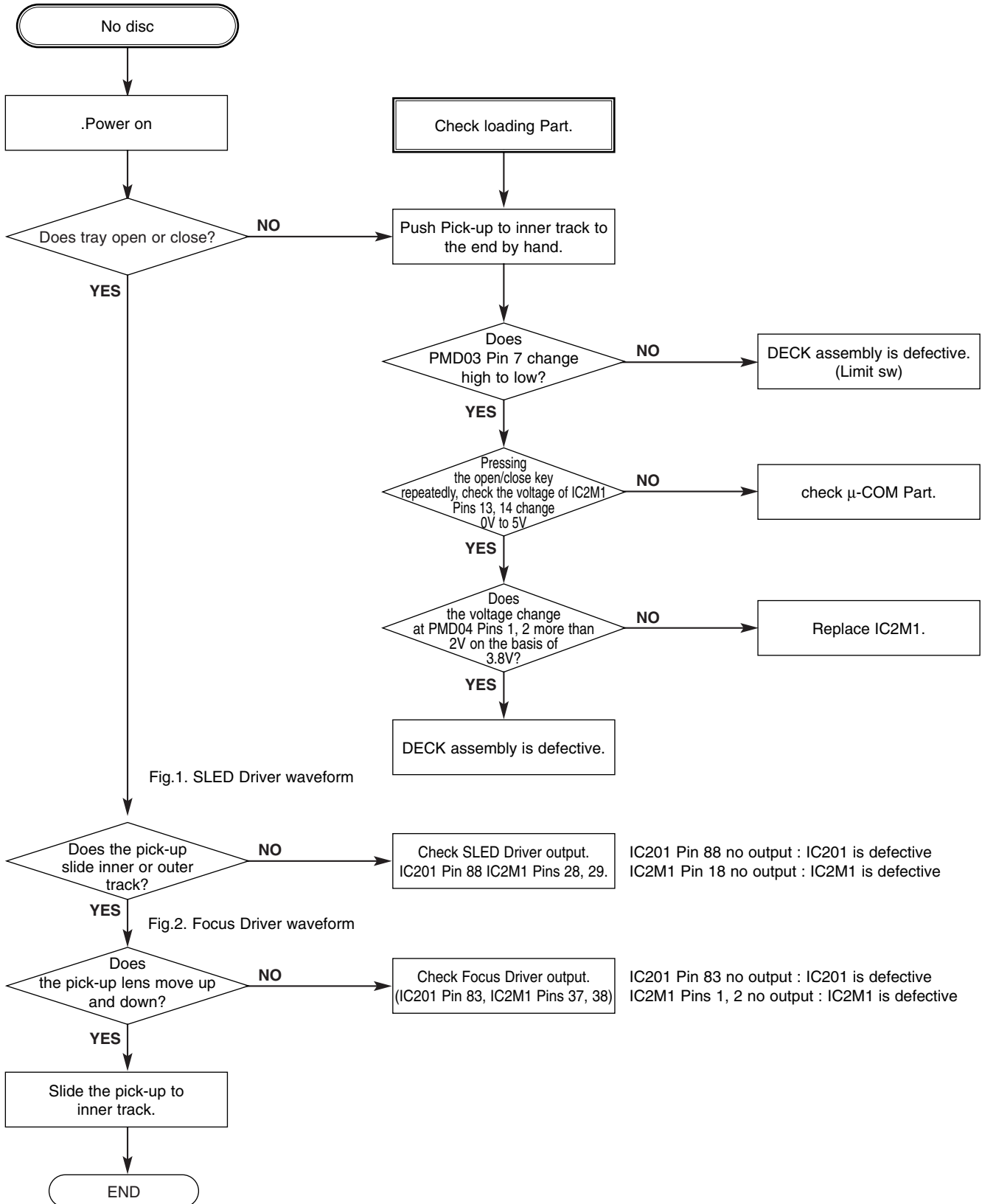

C.

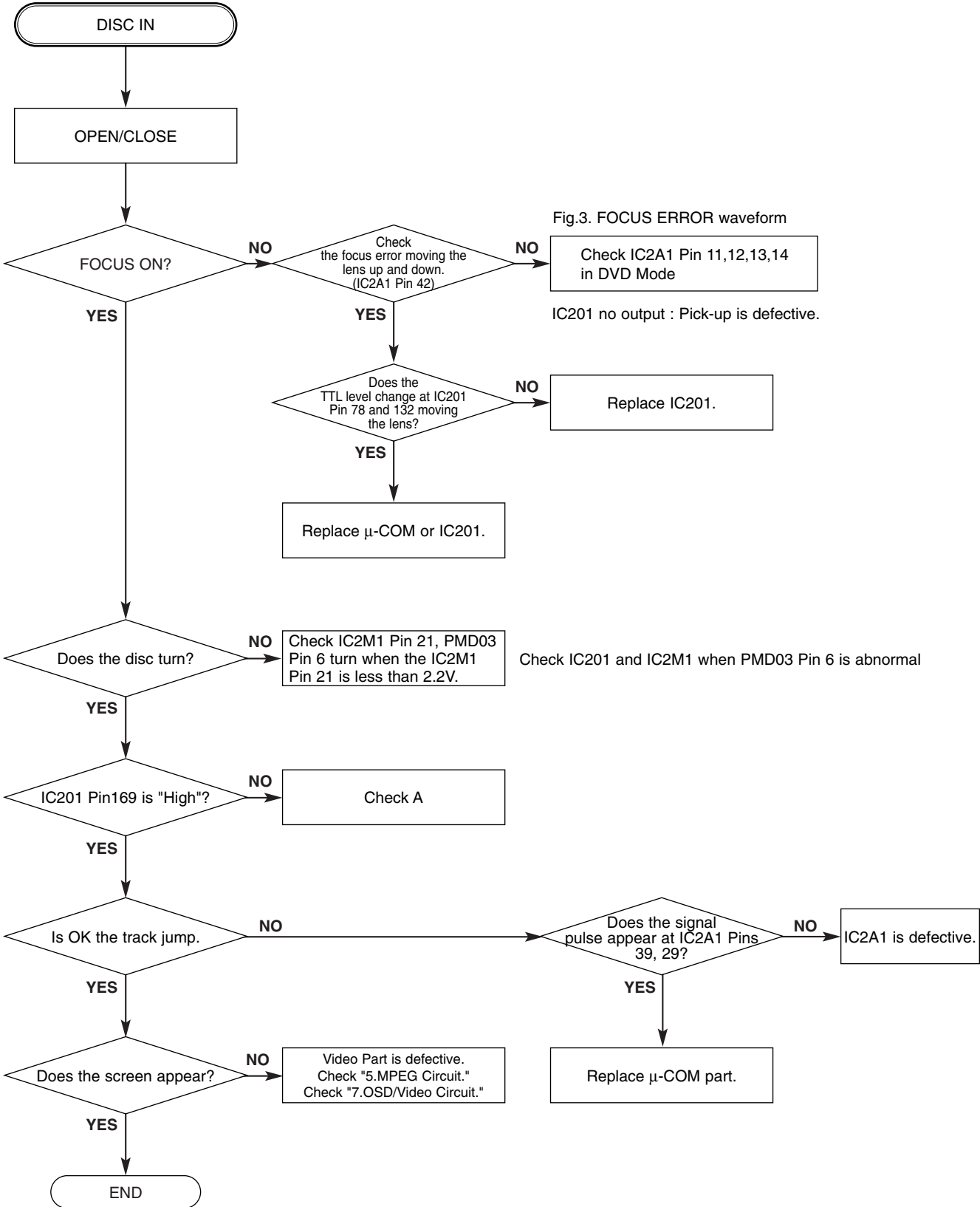

D.

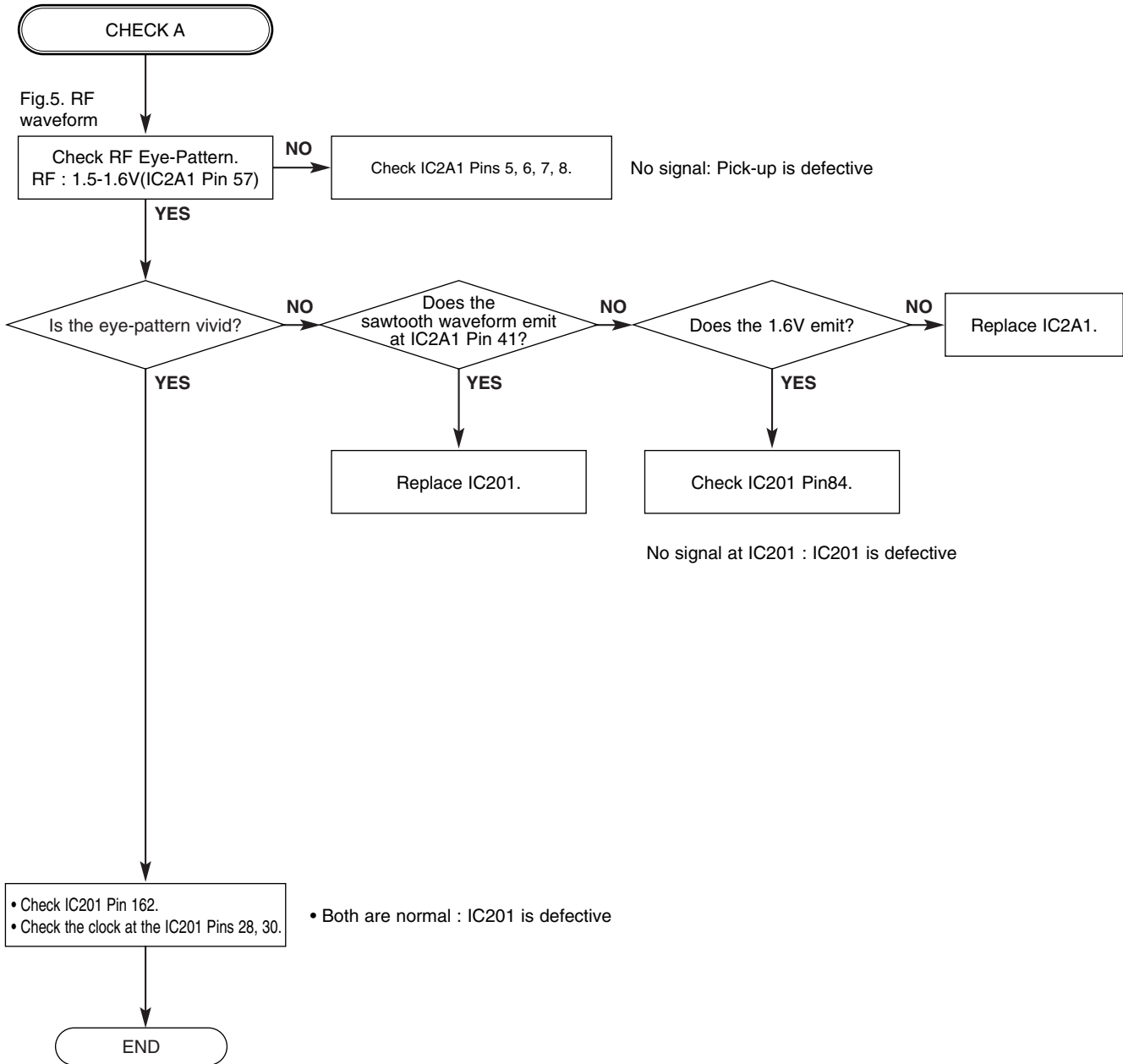

BLOCK DIAGRAM

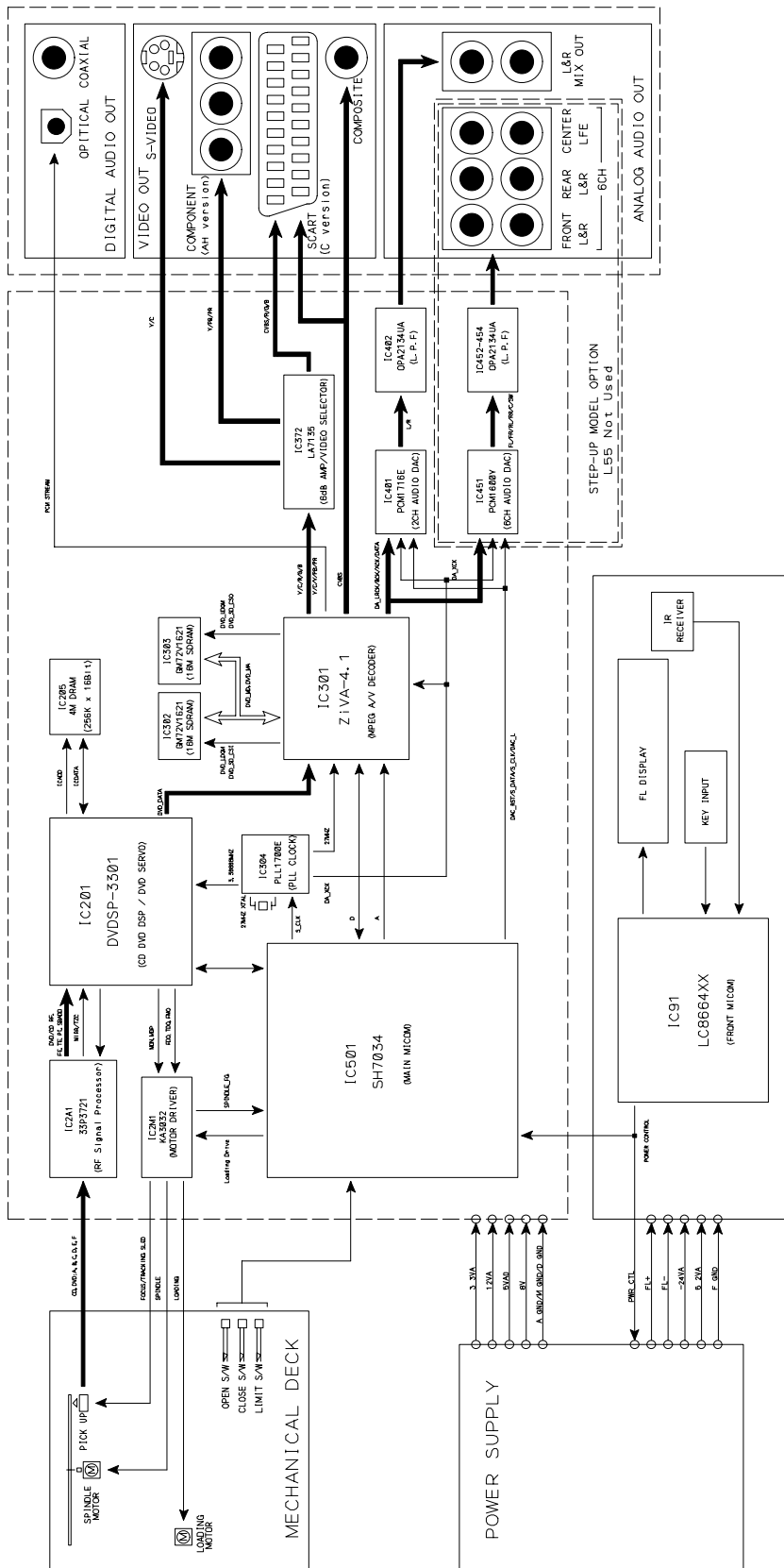

2. Power(SMPS) Block Diagram

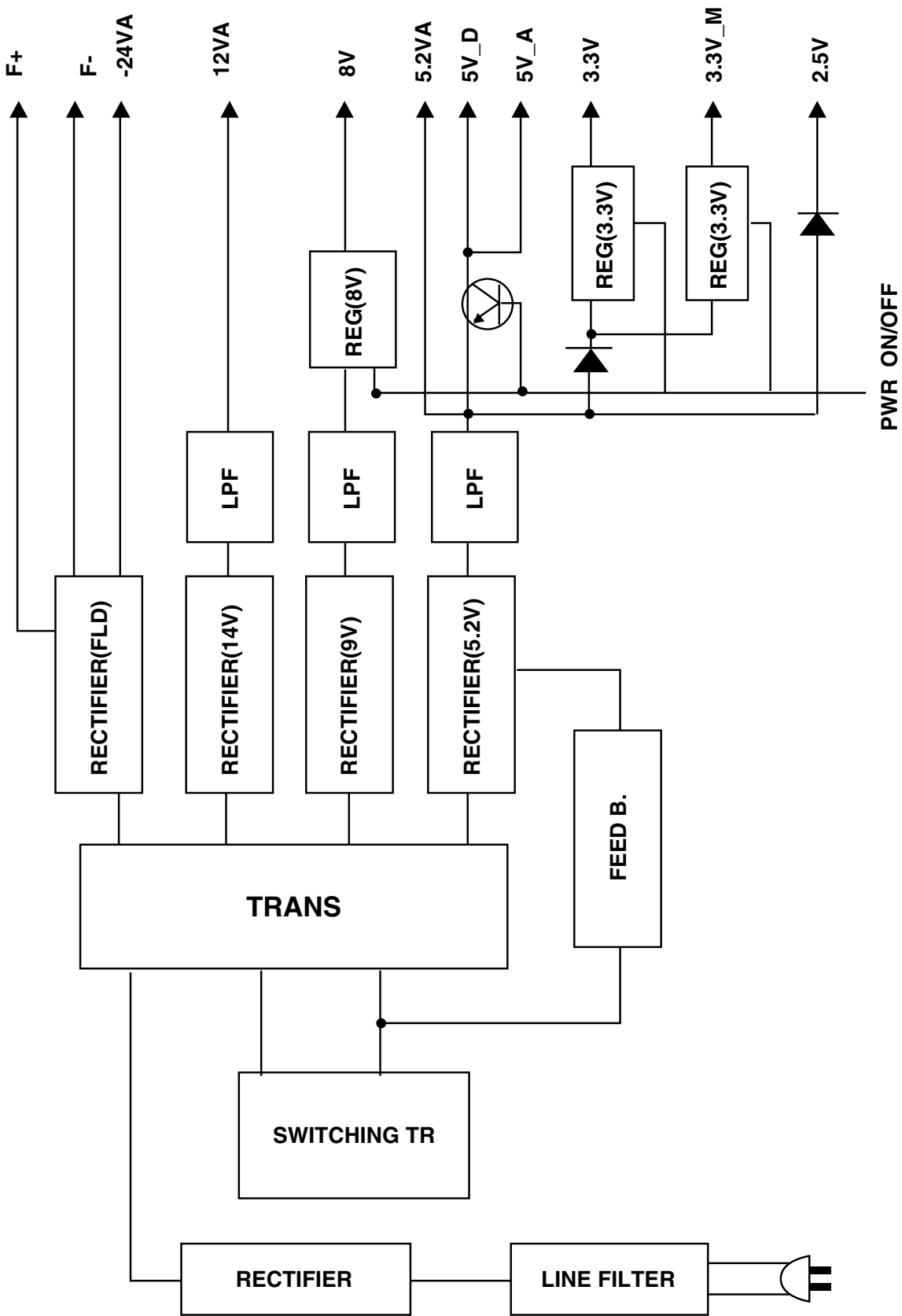

3. RF/CD DSP/DVD DSP/DVD SERVO Block Diagram

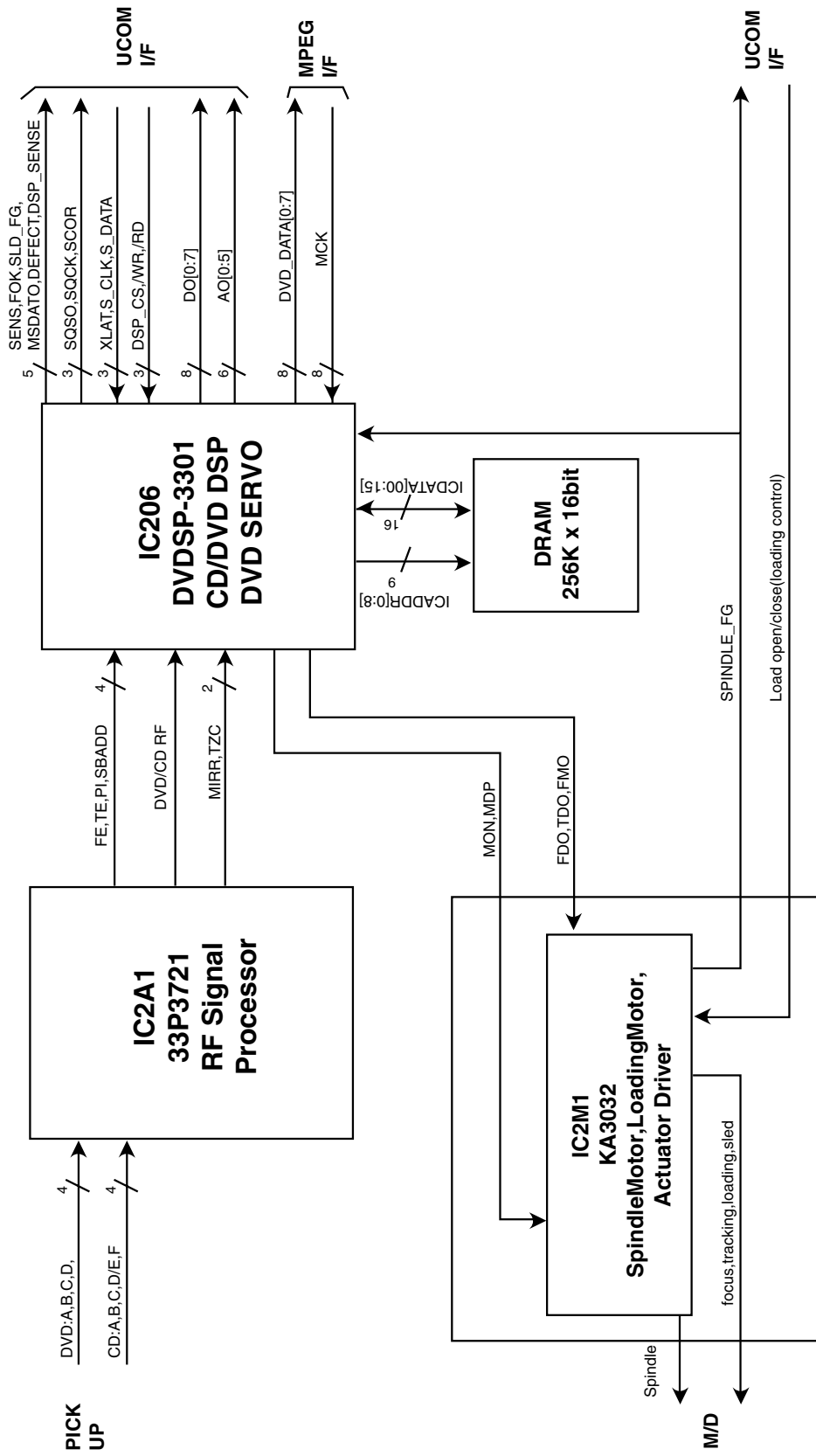

4. Audio Block Diagram

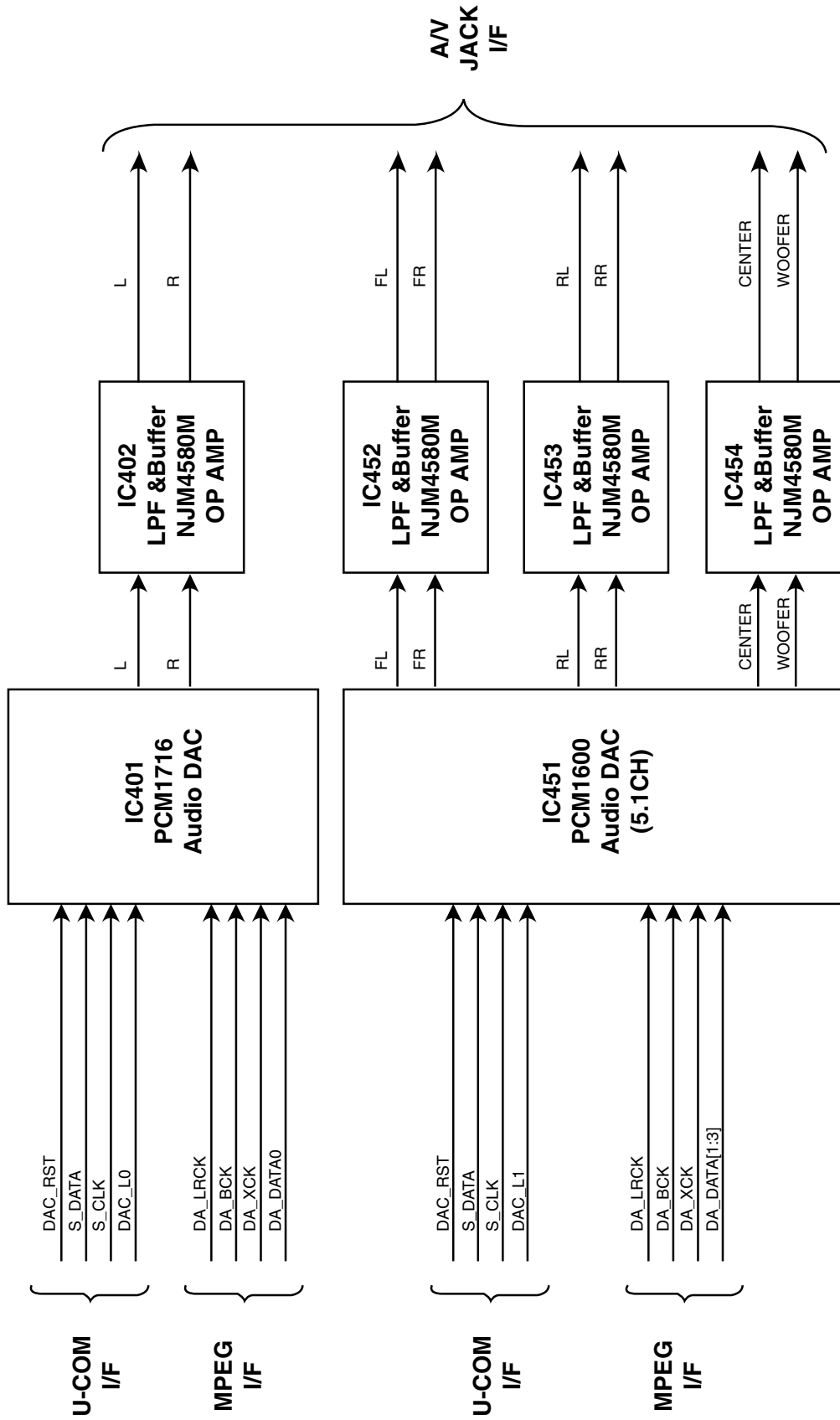

5. MPEG Block Diagram

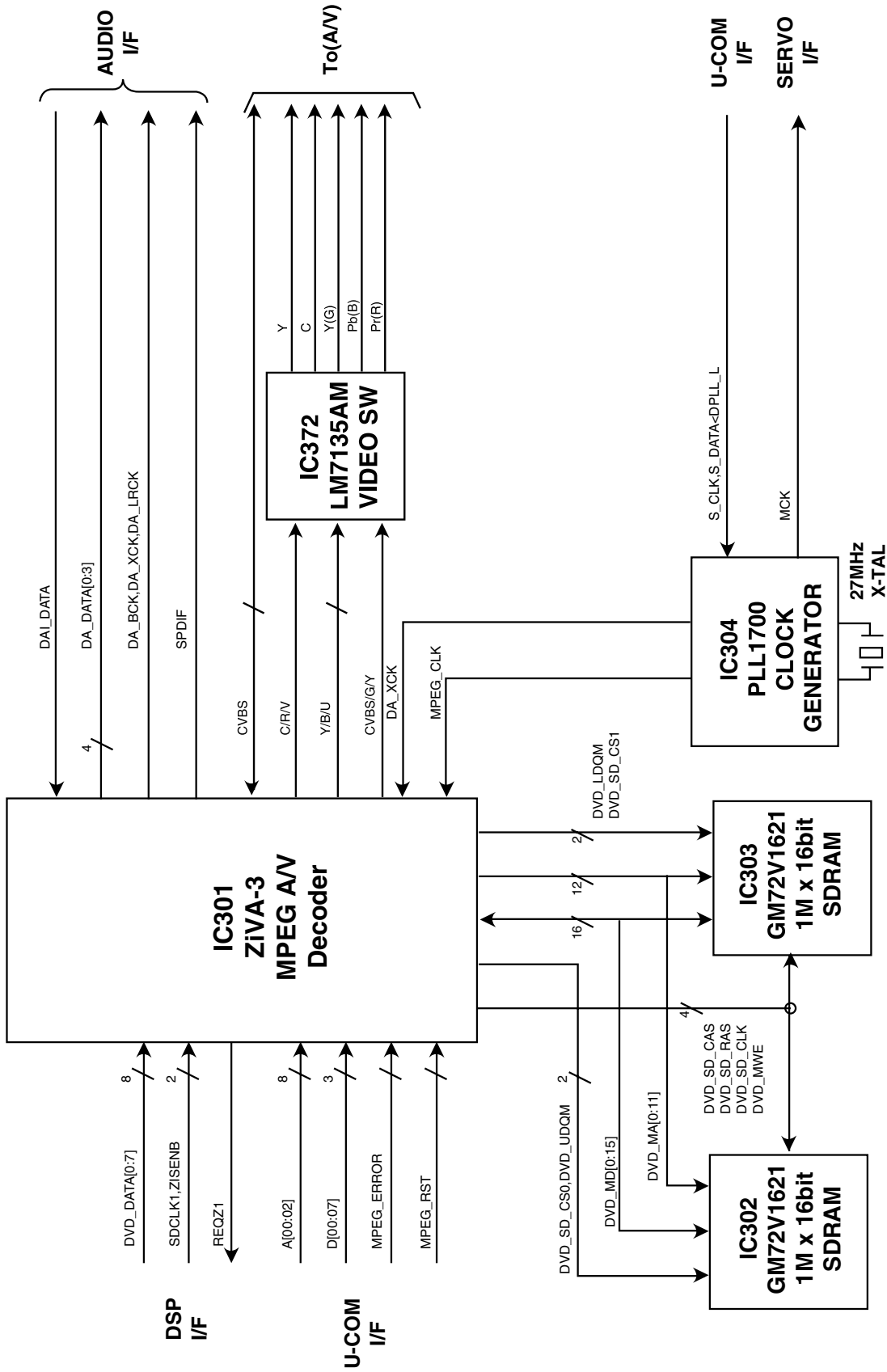

6. μ -COM Block Diagram

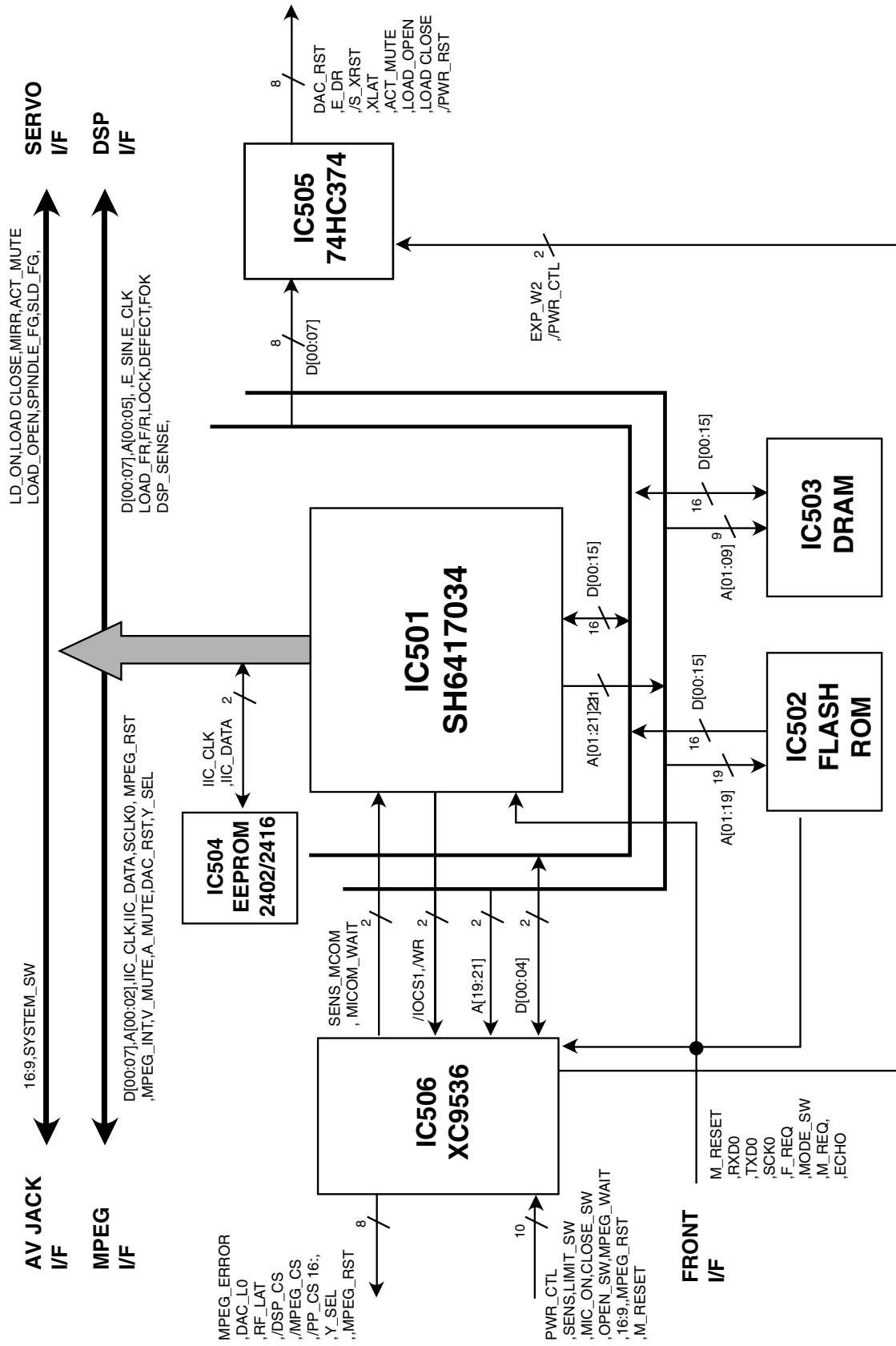

CIRCUIT DIAGRAM

1. POWER (SMPS) CIRCUIT DIAGRAM

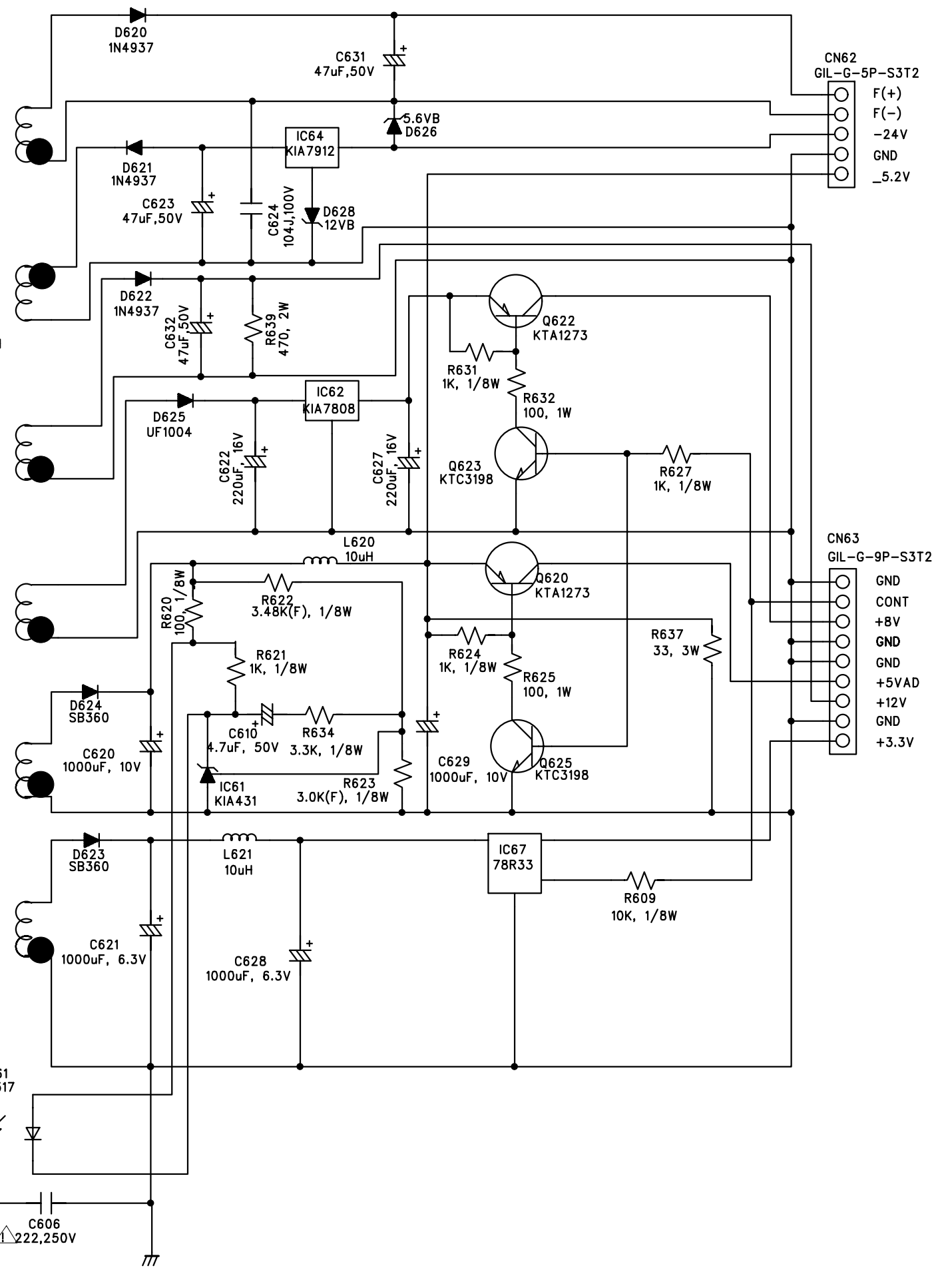
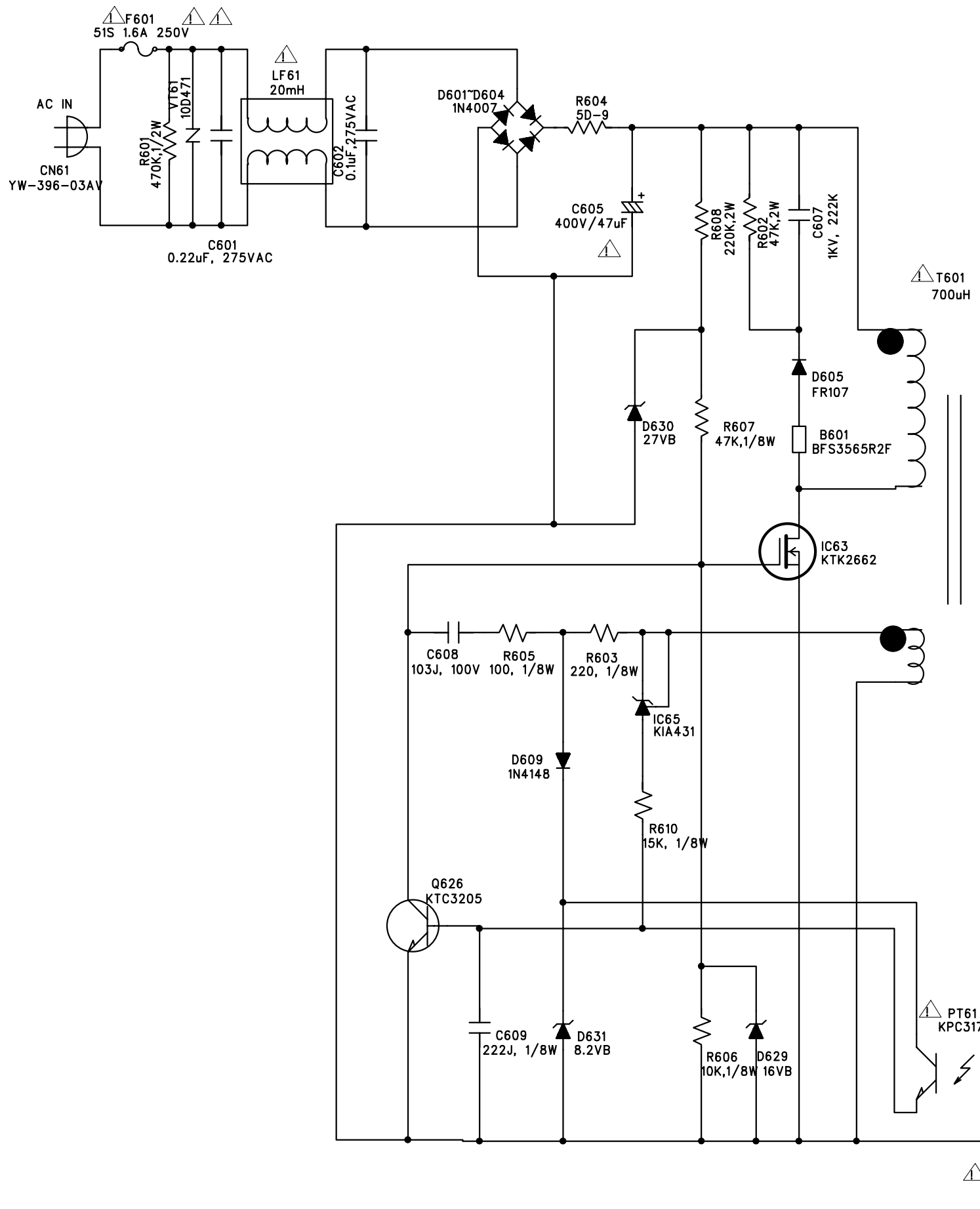

2. DVD DSP CIRCUIT DIAGRAM

LOCATION GUIDE

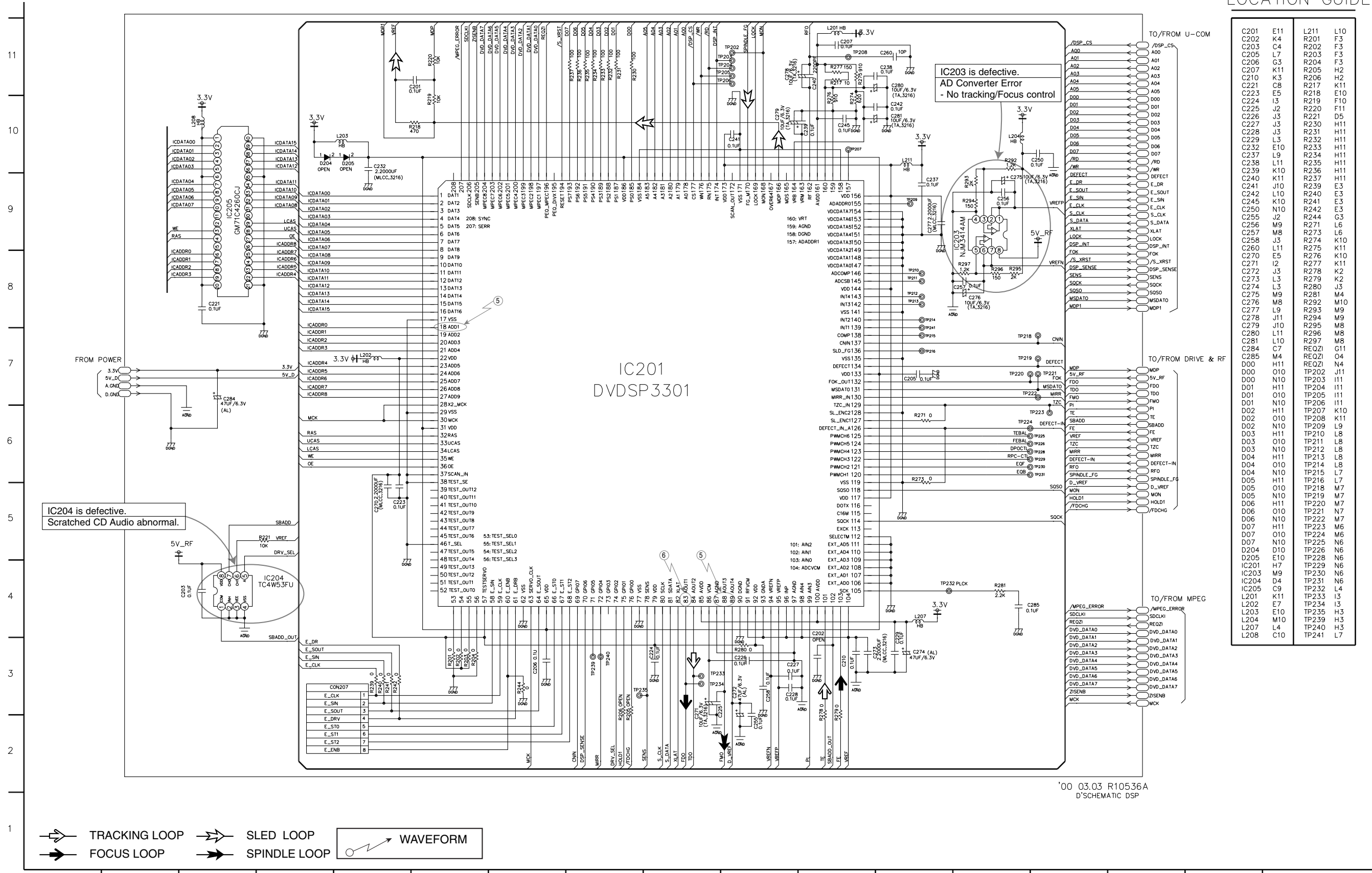

3. DRIVE & RF CIRCUIT DIAGRAM

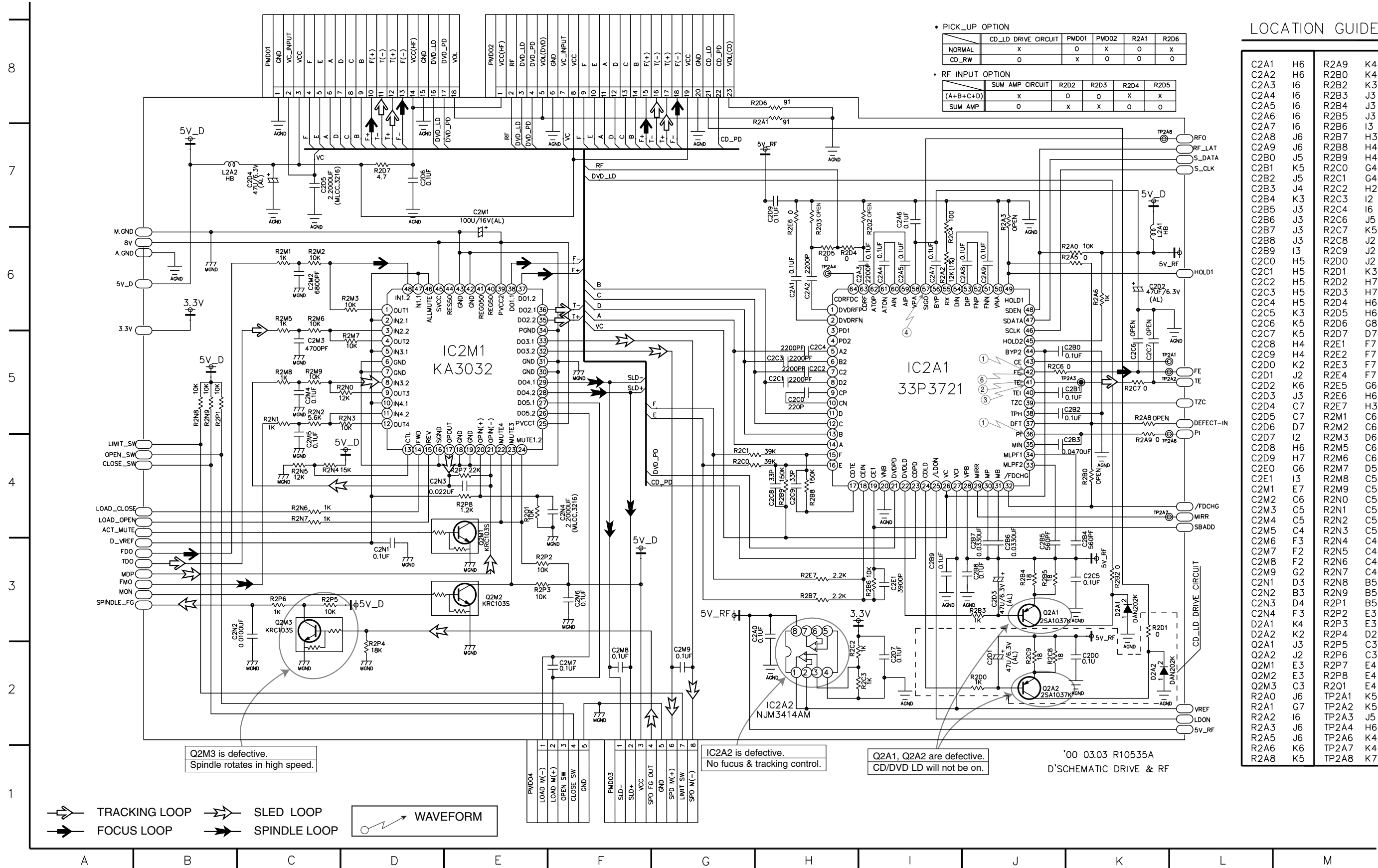

PICK_UP OPTION

	CD_LD DRIVE CIRCUIT	PMD01	PMD02	R2A1	R2D6
NORMAL	X	0	X	0	X
CD_RW	0	X	0	0	0

RF INPUT OPTION

	SUM AMP CIRCUIT	R2D2	R2D3	R2D4	R2D5
(A+B+C+D)	X	0	0	X	X
SUM AMP	0	X	X	0	0

LOCATION GUIDE

C2A1	H6	R2A9	K4
C2A2	H6	R2B0	K4
C2A3	I6	R2B2	K3
C2A4	I6	R2B3	J3
C2A5	I6	R2B4	J3
C2A6	I6	R2B5	J3
C2A7	I6	R2B6	J3
C2A8	J6	R2B7	H3
C2A9	J6	R2B8	H4
C2B0	J5	R2B9	H4
C2B1	K5	R2C0	G4
C2B2	J5	R2C1	G4
C2B3	J4	R2C2	H2
C2B4	K3	R2C3	I2
C2B5	J3	R2C4	I6
C2B6	J3	R2C6	J5
C2B7	J3	R2C7	K5
C2B8	J3	R2C8	J2
C2B9	I3	R2C9	J2
C2C0	H5	R2D0	J2
C2C1	H5	R2D1	K3
C2C2	H5	R2D2	H7
C2C3	H5	R2D3	H7
C2C4	H5	R2D4	H6
C2C5	K3	R2D5	H6
C2C6	K5	R2D6	G8
C2C7	K5	R2D7	D7
C2C8	H4	R2E1	F7
C2C9	H4	R2E2	F7
C2D0	K2	R2E3	F7
C2D1	J2	R2E4	F7
C2D2	K6	R2E5	G6
C2D3	J3	R2E6	H6
C2D4	C7	R2E7	H3
C2D5	C7	R2M1	C6
C2D6	D7	R2M2	C6
C2D7	I2	R2M3	D6
C2D8	H6	R2M5	C6
C2D9	H7	R2M6	C6
C2E0	G6	R2M7	D5
C2E1	I3	R2M8	C5
C2M1	E7	R2M9	C5
C2M2	C6	R2N0	C5
C2M3	C5	R2N1	C5
C2M4	C5	R2N2	C5
C2M5	C4	R2N3	C5
C2M6	F3	R2N4	C4
C2M7	F2	R2N5	C4
C2M8	F2	R2N6	C4
C2M9	G2	R2N7	C4
C2N1	D3	R2N8	B5
C2N2	B3	R2N9	B5
C2N3	D4	R2P1	B5
C2N4	F3	R2P2	E3
D2A1	K4	R2P3	E3
D2A2	K2	R2P4	D2
Q2A1	J3	R2P5	C3
Q2A2	J2	R2P6	C3
Q2M1	E3	R2P7	E4
Q2M2	E3	R2P8	E4
Q2M3	C3	R2O1	E4
R2A0	J6	TP2A1	K5
R2A1	G7	TP2A2	K5
R2A2	I6	TP2A3	J5
R2A3	J6	TP2A4	H6
R2A5	J6	TP2A6	K4
R2A6	K6	TP2A7	K4
R2A8	K5	TP2A8	K7

Q2M3 is defective.
Spindle rotates in high speed.

IC2A2 is defective.
No focus & tracking control.

Q2A1, Q2A2 are defective.
CD/DVD LD will not be on.

'00 03.03 R10535A
D'SCHEMATIC DRIVE & RF

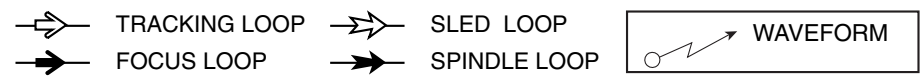

4. MPEG CIRCUIT DIAGRAM

LOCATION GUIDE

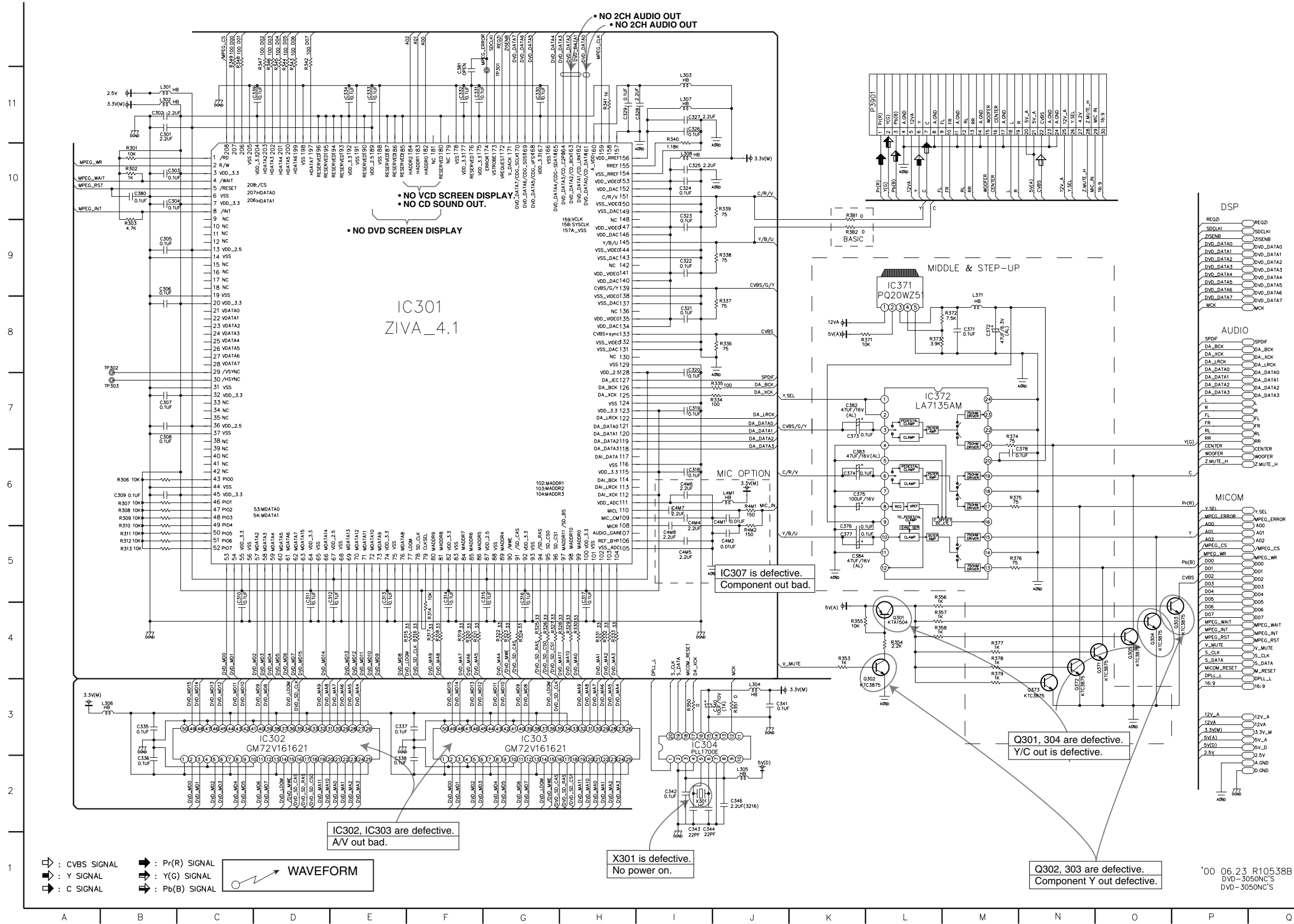

C301	B11	Q301	L4
C302	B11	Q302	K3
C303	B10	Q303	P4
C304	B10	Q304	O4
C305	B9	Q305	O4
C306	B9	Q371	O4
C307	B7	Q372	N3
C308	B7	Q373	N3
C309	B6	R301	B10
C310	C4	R302	B10
C311	D4	R303	B9
C312	E4	R306	B6
C313	E4	R307	B6
C314	F4	R308	B6
C315	G4	R309	B6
C316	G4	R310	B5
C317	H4	R311	B5
C318	I6	R312	B5
C319	I7	R313	B5
C320	I8	R314	F4
C321	I8	R315	F4
C322	I9	R316	F4
C323	I10	R317	F4
C324	I10	R318	F4
C325	I10	R319	F4
C326	I11	R320	F4
C327	I11	R321	F4
C328	I11	R322	G4
C329	H11	R323	G4
C330	G11	R324	G4
C331	F11	R325	G4
C332	F11	R326	G4
C333	E11	R327	G4
C334	E11	R328	H4
C335	B5	R329	H4
C336	B2	R330	H4
C337	E3	R331	H4
C338	E2	R332	H4
C339	D11	R333	H4
C340	J3	R334	I7
C341	J3	R335	I7
C342	I2	R336	J8
C343	I2	R337	J8
C344	I2	R338	J9
C346	J2	R339	J10
C371	M8	R340	I11
C372	M8	R341	H11
C373	K7	R342	D11
C374	K6	R343	D11
C375	K6	R344	D11
C376	K5	R345	D11
C377	K5	R346	D11
C378	M6	R347	D11
C380	B10	R348	C11
C381	F11	R349	C11
C382	K7	R350	J3
C383	K6	R351	J3
C384	K5	R353	K4
C3K1	L2	R354	L4
C4M1	J6	R355	K4
C4M2	J5	R356	L5
C4M4	I6	R357	L4
C4M5	I5	R358	L4
C4M6	I6	R371	K8
C4M7	I6	R372	M8
C4M8	I5	R373	L8
IC301	E8	R374	M7
IC302	D3	R375	M6
IC303	G3	R376	M5
IC304	I3	R377	M4
IC371	L9	R378	M4
IC372	L7	R379	M4
IC3K1	K3	R381	K10
L301	B11	R382	K9
L302	B11	R3K1	K3
L303	I11	R3K2	L2
L304	J3	R4M1	J6
L305	J2	R4M2	J5
L306	B3	REOZ1	G12
L307	I11	REOZ1	O9
L308	I10	REOZ1	P9
L371	M8	TP301	G11
L4M1	J6	TP302	B8
P3901	L10	TP303	B7
Pb(B)	L11		
Pb(B)	P5		

'00 06.23 R10538B
DVD-3050NC'S
DVD-3050NC'S

4-1. WAVEFORMS (RF/SERVO)

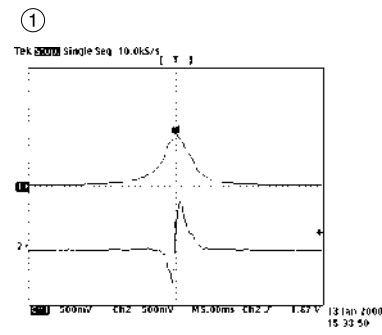

IC2A1 Pin 42, Focus Error
IC2A1 Pin 36, Pi

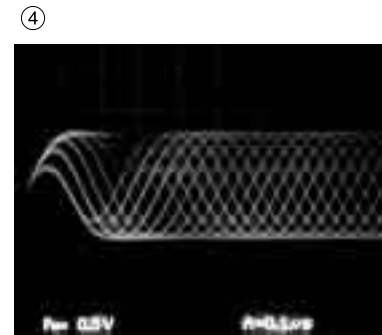

IC2A1 Pin 57,
RF

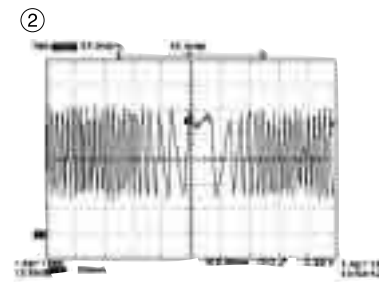

IC2A1 Pin 41
Tracking Error

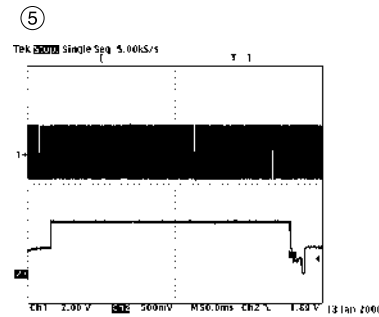

IC201 Pin 88, SLED Drive(FMO)
IC201 Pin 18, SLED FG

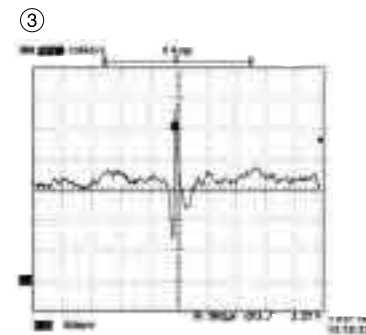

IC2A1 Pin 41
VBR TRACKING Error

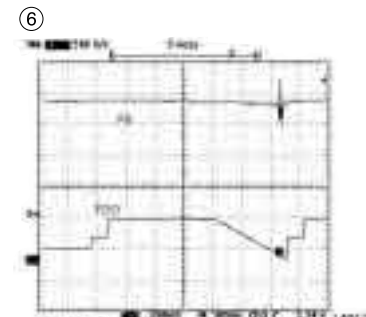

IC2A1 Pin42, Focus Error(in Focus Search)
IC201 Pin 83, Focus Drive(FDO)

(VIDEO ENCODER)

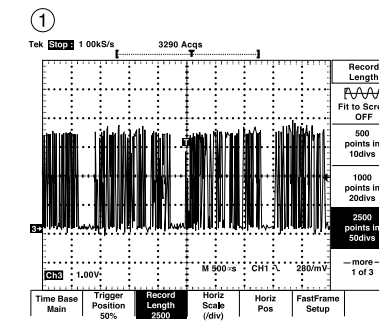

IC305 Pins 9~16, MPEG Data

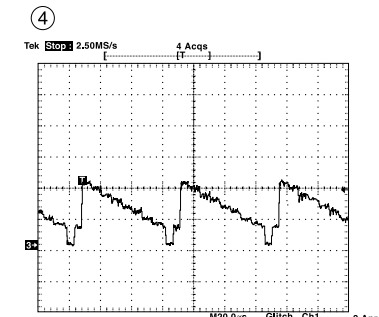

IC305 Pin 27, Luminance

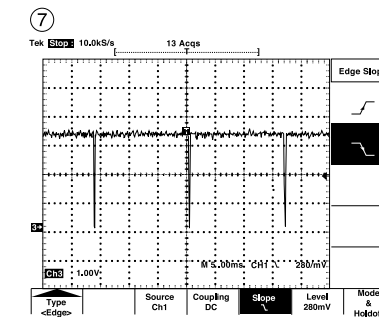

IC305 Pin 7, Vertical SYNC

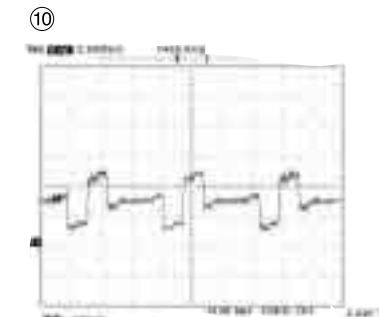

IC305 Pin 23 Component Pr

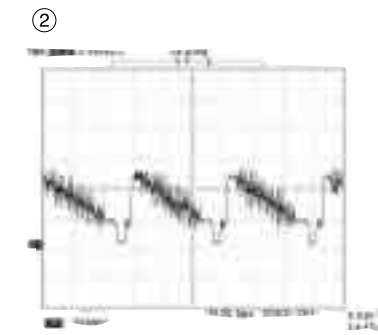

IC305 Pin 30, Composite

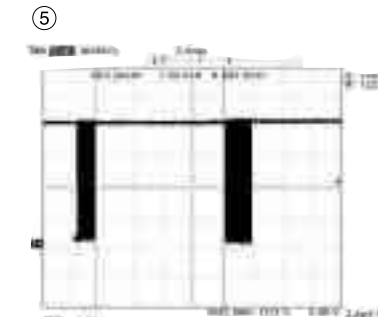

IC305 Pins 40, 41 SDA/SCL

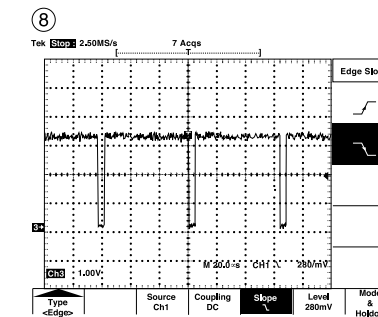

IC305 Pin 8 Horizontal SYNC

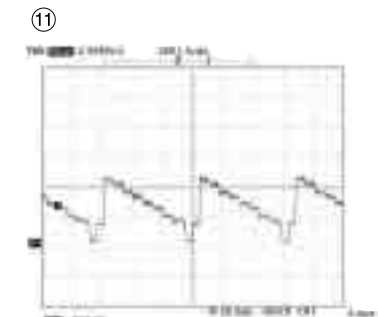

IC305 Pin 27 Component Y

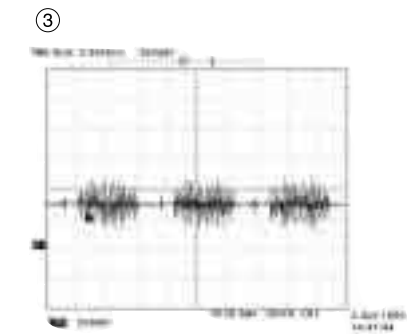

IC305 Pin 24, Chrominance

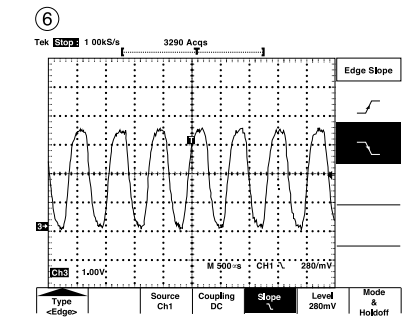

IC305 Pin 4, MPEG Clock(27MHz)



IC305 Pin 29 Component Pb

5. Audio DM & 5.1CH Circuit Diagram

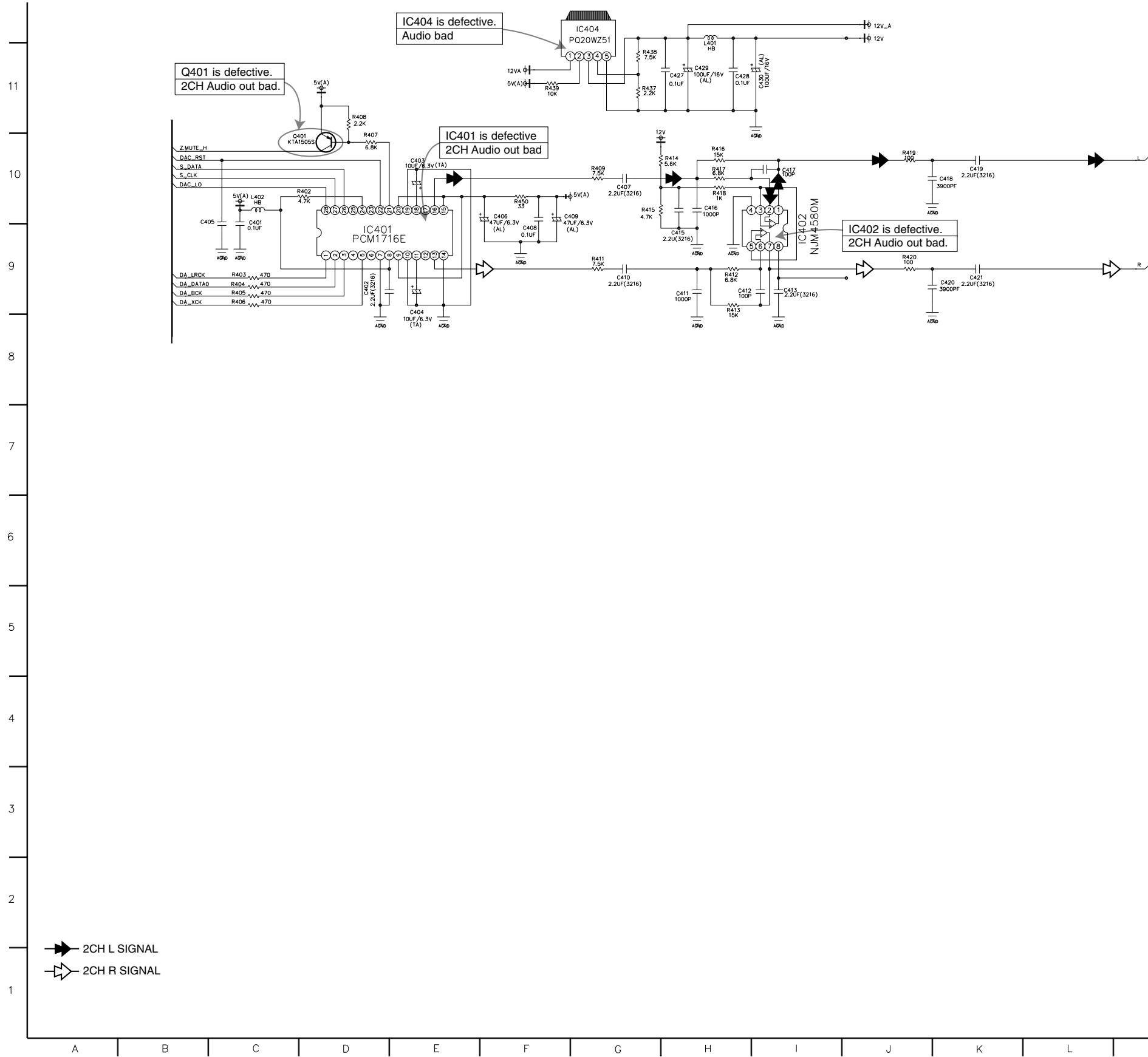

LOCATION GUIDE

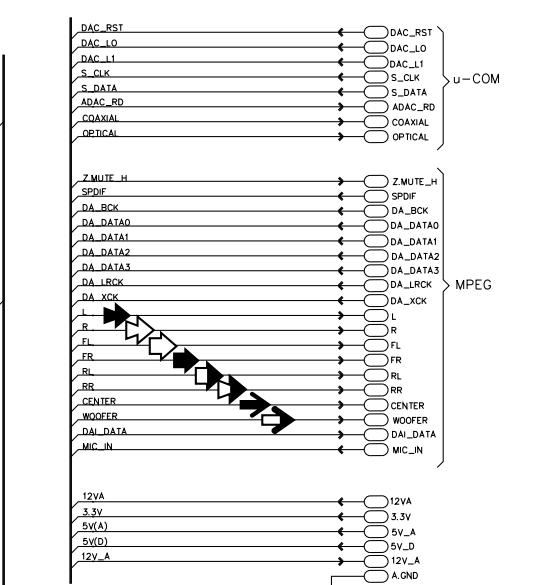

C401	C9	Q401	C10
C402	D9	Q404	O4
C403	E10	R402	C10
C404	E9	R403	C9
C405	B10	R404	C9
C406	F10	R405	C9
C407	G10	R406	C9
C408	F9	R407	D10
C409	F10	R408	D11
C410	G9	R409	G10
C411	H9	R411	C9
C412	H9	R412	H9
C413	I9	R413	H9
C415	H9	R414	H10
C416	H10	R415	G10
C417	I10	R416	H10
C418	K10	R417	H10
C419	K10	R418	H10
C420	K9	R419	J10
C421	K9	R420	J9
C422	N5	R425	N5
C423	P4	R426	N4
C424	N3	R427	O4
C427	H11	R428	N3
C428	H11	R429	N3
C429	H11	R437	G11
C430	I11	R438	G11
C450	B6	R439	F11
C451	C6	R450	F10
C452	E7	R451	C4
C453	F6	R452	C4
C454	D4	R453	C4
C455	G8	R454	C4
C456	H7	R455	C3
C457	H7	R456	C3
C458	I8	R457	G8
C459	K8	R458	H8
C460	K8	R459	G7
C461	G7	R460	H8
C462	H7	R461	H8
C463	H7	R462	H8
C464	I7	R463	J8
C465	K7	R465	K8
C466	K7	R466	L8
C467	G6	R467	G7
C468	H5	R468	H7
C469	H5	R469	H6
C470	I6	R470	J7
C471	K6	R472	L7
C472	K6	R473	L7
C473	G5	R474	G6
C474	H4	R475	H6
C475	H4	R476	G5
C476	I4	R477	H6
C478	K5	R478	H6
C479	K5	R479	H6
C480	G3	R480	J6
C481	H3	R482	L6
C482	H3	R483	L6
C483	I4	R484	G5
C484	K4	R485	H5
C485	K4	R486	H4
C486	G2	R487	J5
C487	H2	R489	L5
C488	H2	R490	L5
C490	K2	R491	G4
C491	K2	R492	H4
C492	I2	R493	G3
C4M1	O6	R494	H4
C4M2	O5	R495	H4
C4M3	O6	R496	H4
C4M4	O6	R497	J4
IC401	D9	R499	L4
IC402	I9	R4A1	L4
IC403	N5	R4A2	G3
IC404	G12	R4A3	H3
IC451	D6	R4A4	H2
IC452	I7	R4A6	J3
IC453	I5	R4A8	L3
IC454	I3	R4A9	L2
IC4M1	N6	R4M1	N6
L401	H11	R4M2	N6
L402	C10	R4M3	N6
L451	C5	R4M4	N5
L452	C7	R4M5	O6
L4M1	O6	R4M6	O5

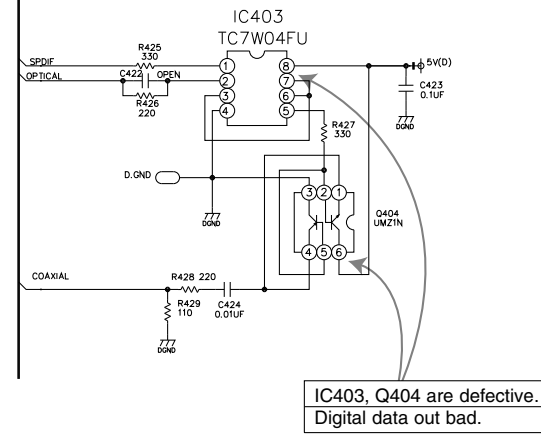

'00 01.17 R10539B
DVD3351ND'S

6. μ -com/ Expander

LOCATION GUIDE

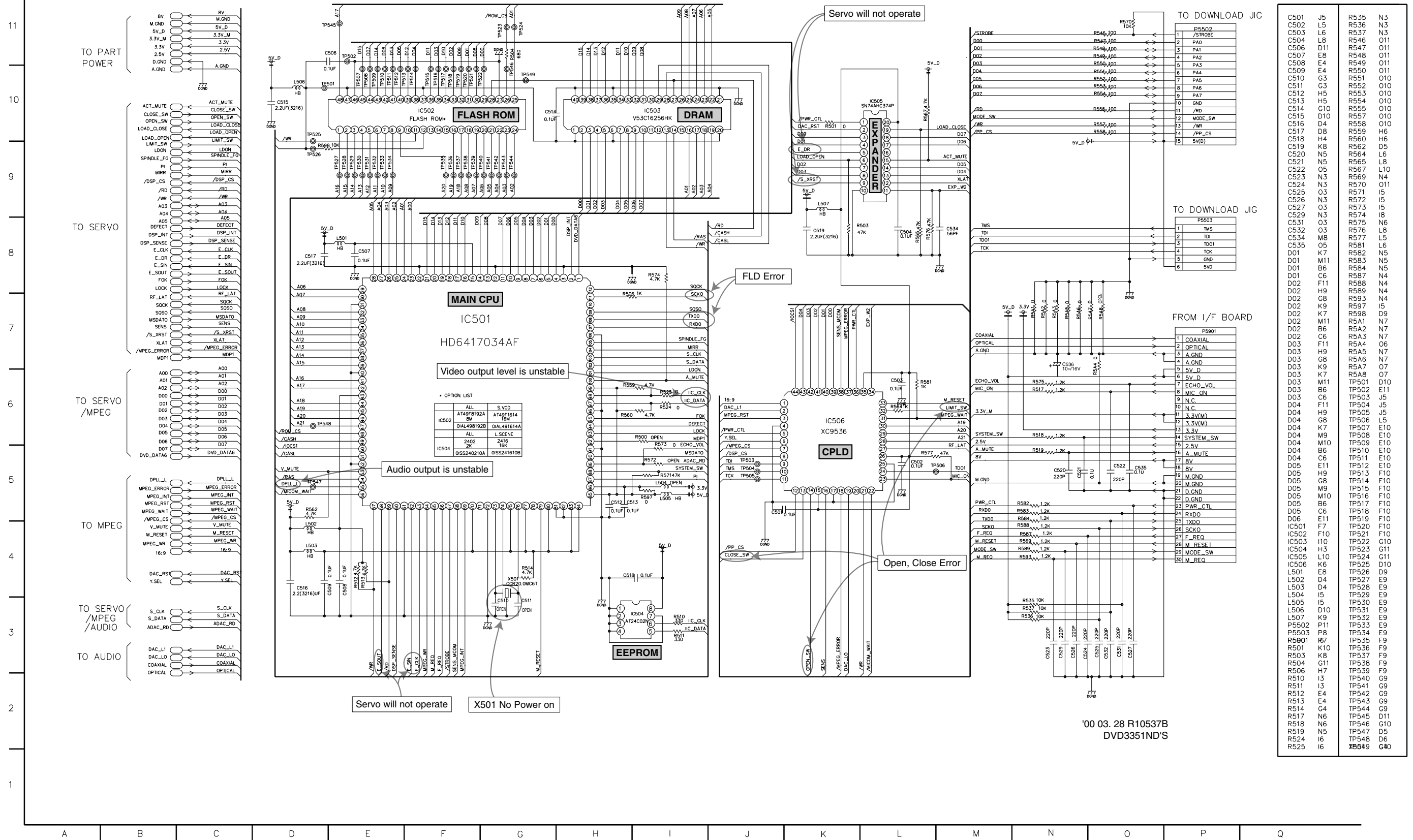

C501	J5	R535	N3
C502	L5	R536	N3
C503	L6	R537	N3
C504	L8	R546	O11
C506	D11	R547	O11
C507	E8	R548	O11
C508	E4	R549	O11
C509	E4	R550	O11
C510	G3	R551	O10
C511	G3	R552	O10
C512	H5	R553	O10
C513	H5	R554	O10
C514	G10	R555	O10
C515	D10	R557	O10
C516	D4	R558	O10
C517	D8	R559	H6
C518	H4	R560	H6
C519	K8	R562	D5
C520	N5	R564	L6
C521	N5	R565	L8
C522	O5	R567	L10
C523	N3	R569	N4
C524	N3	R570	O11
C525	O3	R571	I5
C526	N3	R572	I5
C527	O3	R573	I5
C529	N3	R574	I8
C531	O3	R575	N6
C532	O3	R576	L8
C534	M8	R577	L5
C535	O5	R581	L6
D01	K7	R582	N5
D01	M11	R583	N5
D01	B6	R584	N5
D01	C6	R587	N4
D02	F11	R588	N4
D02	H9	R589	N4
D02	G8	R593	N4
D02	K9	R597	I5
D02	K7	R598	D9
D02	M11	R5A1	N7
D02	B6	R5A2	N7
D02	C6	R5A3	N7
D03	F11	R5A4	O6
D03	H9	R5A5	N7
D03	G8	R5A6	N7
D03	K9	R5A7	O7
D03	K7	R5A8	O7
D03	M11	TP501	D10
D03	B6	TP502	E11
D03	C6	TP503	J5
D04	F11	TP504	J5
D04	H9	TP505	J5
D04	G8	TP506	L5
D04	K7	TP507	E10
D04	M9	TP508	E10
D04	M10	TP509	O10
D04	B6	TP510	E10
D04	C6	TP511	E10
D04	E11	TP512	E10
D05	H9	TP513	F10
D05	G8	TP514	F10
D05	M9	TP515	F10
D05	M10	TP516	F10
D05	B6	TP517	F10
D05	C6	TP518	F10
D06	E11	TP519	F10
IC501	F7	TP520	F10
IC502	F10	TP521	F10
IC503	I10	TP522	G10
IC504	H3	TP523	G11
IC505	L10	TP524	G11
IC506	K6	TP525	D10
L501	E8	TP526	D9
L502	D4	TP527	E9
L503	D4	TP528	E9
L504	I5	TP529	E9
L505	I5	TP530	E9
L506	D10	TP531	E9
L507	K9	TP532	E9
P5502	P11	TP533	E9
P5503	P8	TP534	E9
R5801	R7	TP535	F9
R501	K10	TP536	F9
R503	K8	TP537	F9
R504	G11	TP538	F9
R506	H7	TP539	F9
R510	I3	TP540	G9
R511	I3	TP541	G9
R512	E4	TP542	G9
R513	E4	TP543	G9
R514	G4	TP544	G9
R517	N6	TP545	D11
R518	N6	TP546	G10
R519	N5	TP547	D5
R524	I6	TP548	D6
R525	I6	XB049	G40

7. DIGITRON & KEY CIRCUIT DIAGRAM

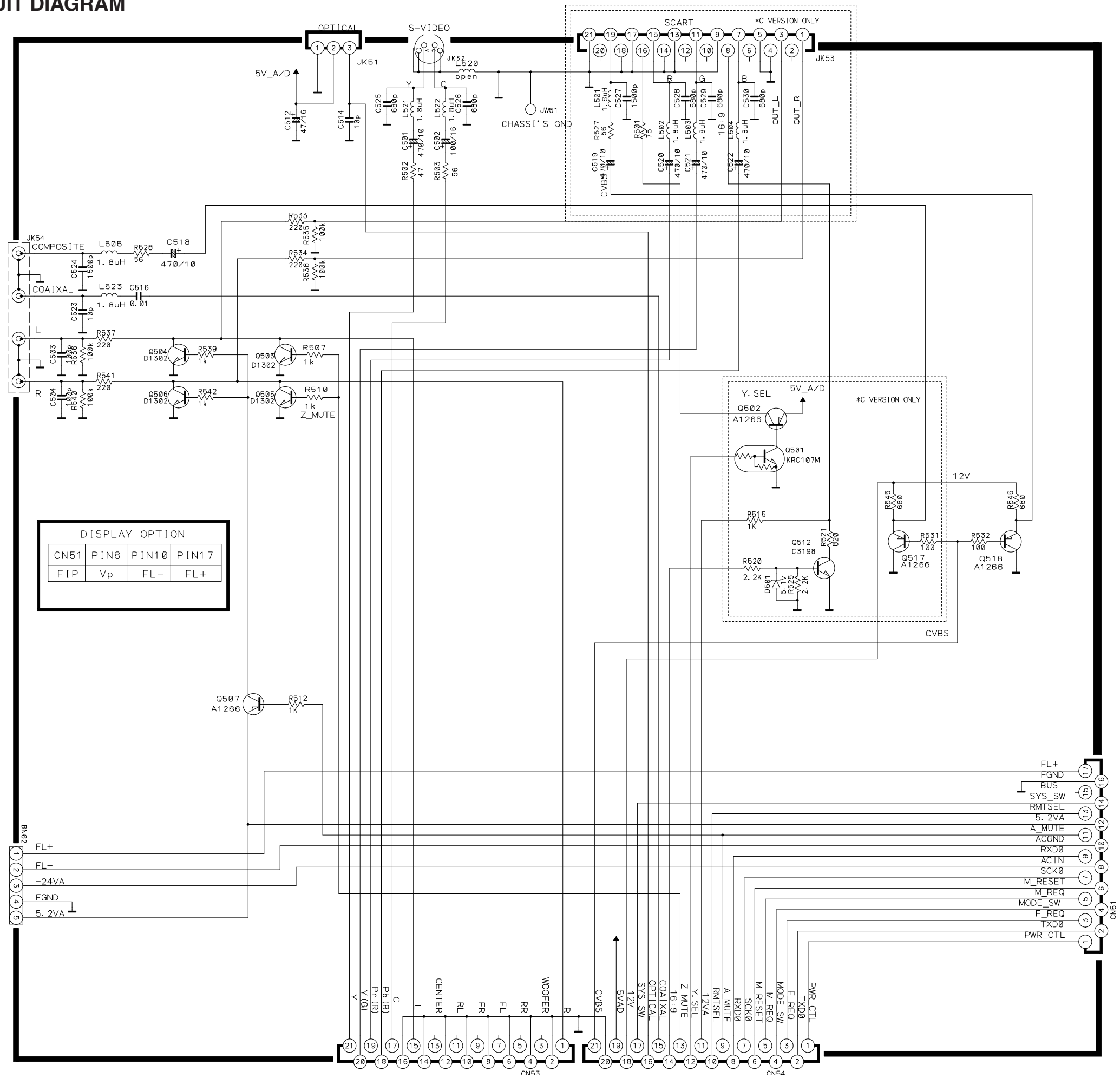

8. JACK CIRCUIT DIAGRAM

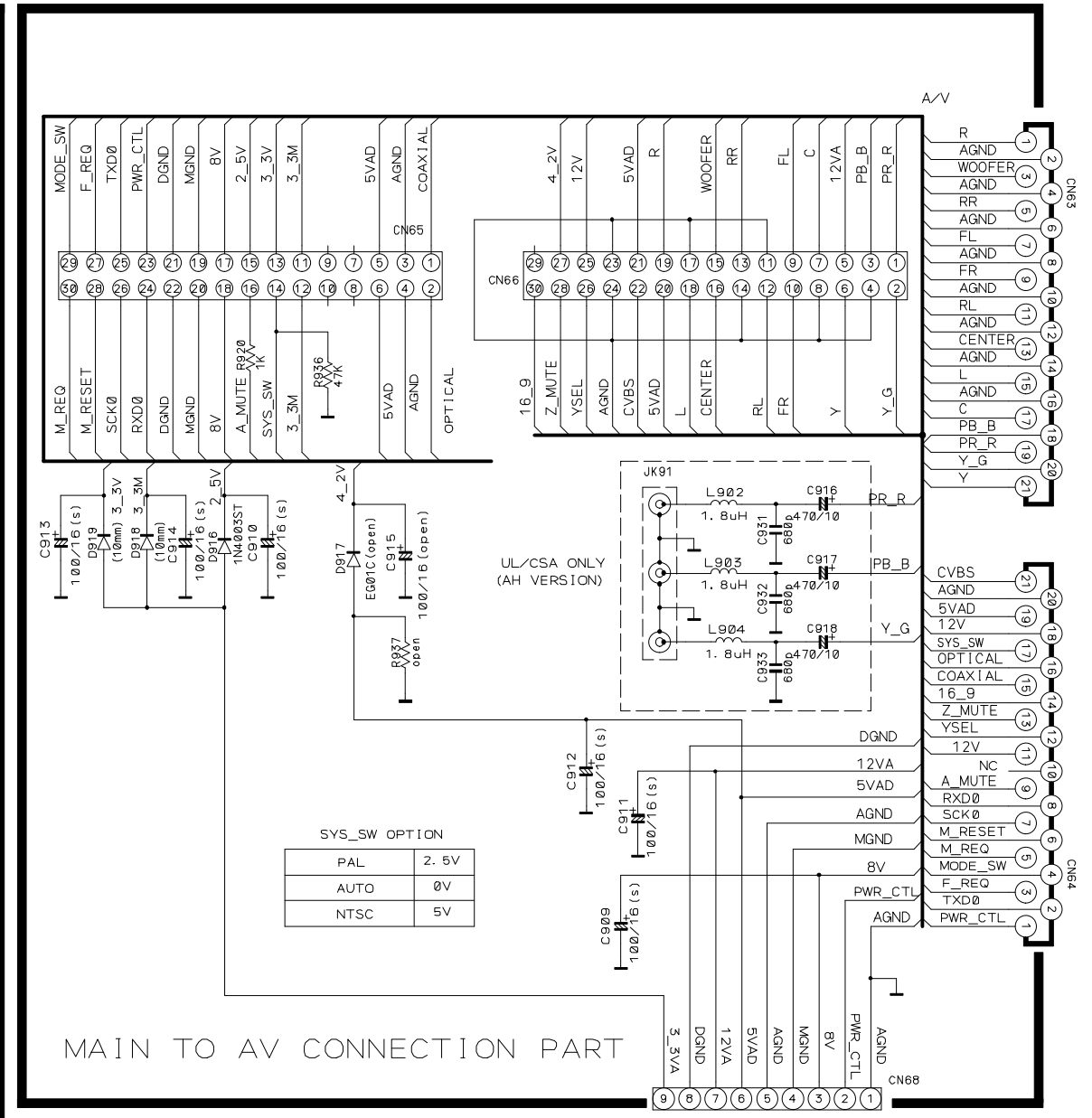
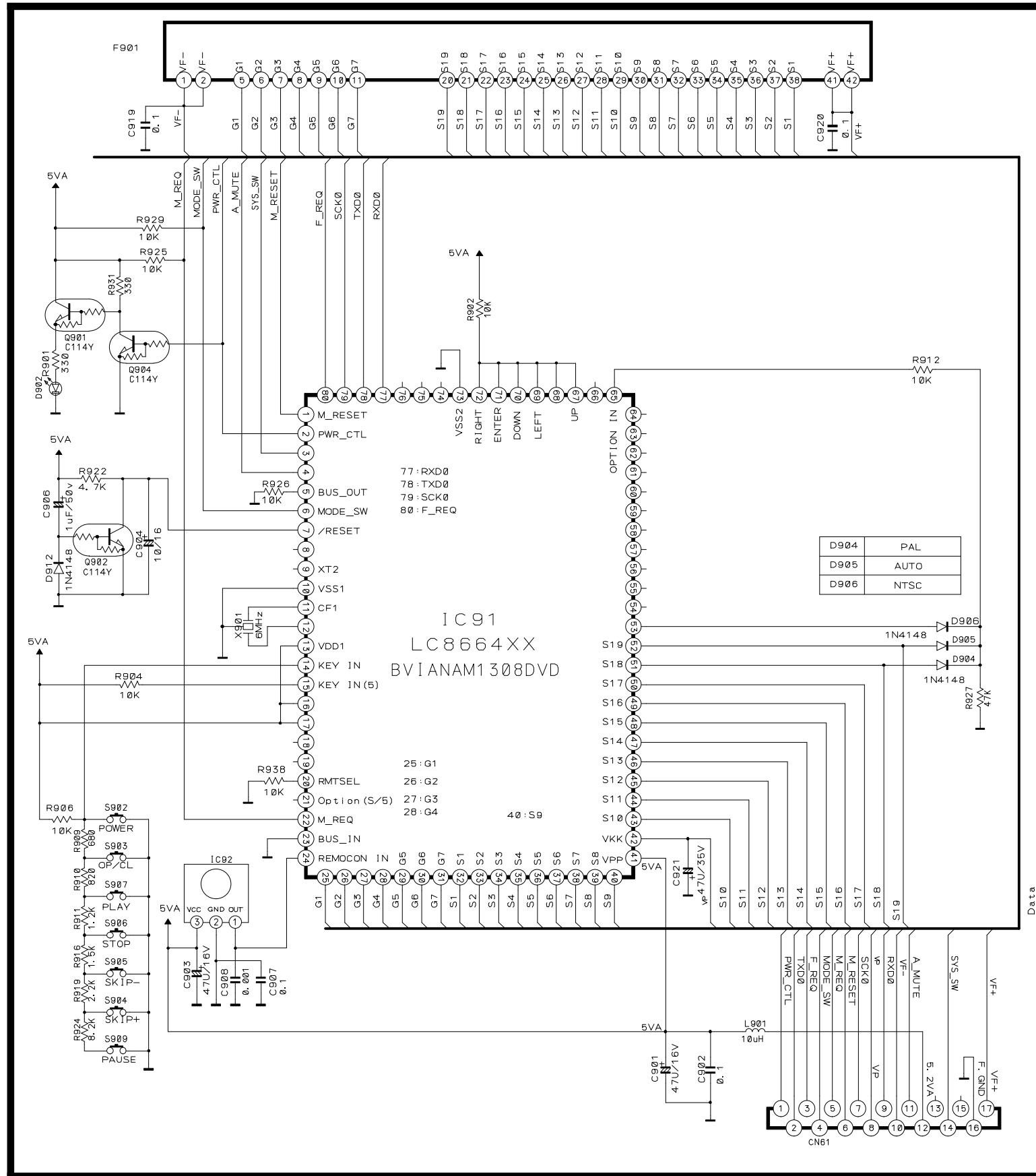

MAIN TO AV CONNECTION PART

2. POWER P.C.BOARD

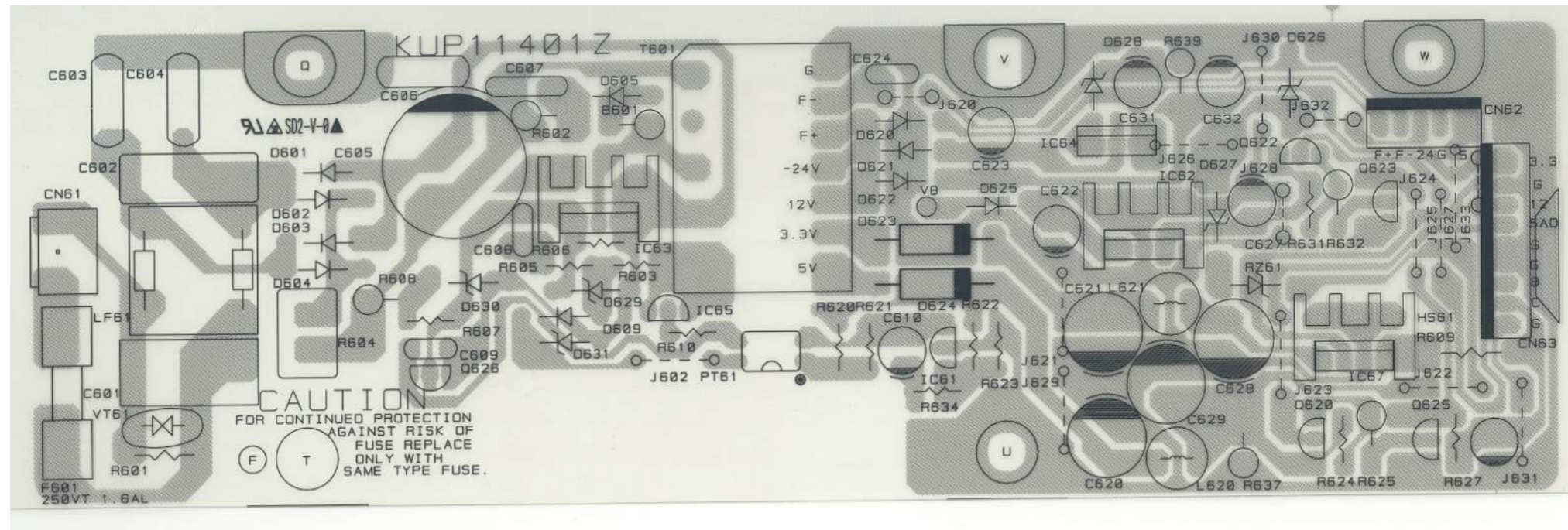

3. AV P.C.BOARD

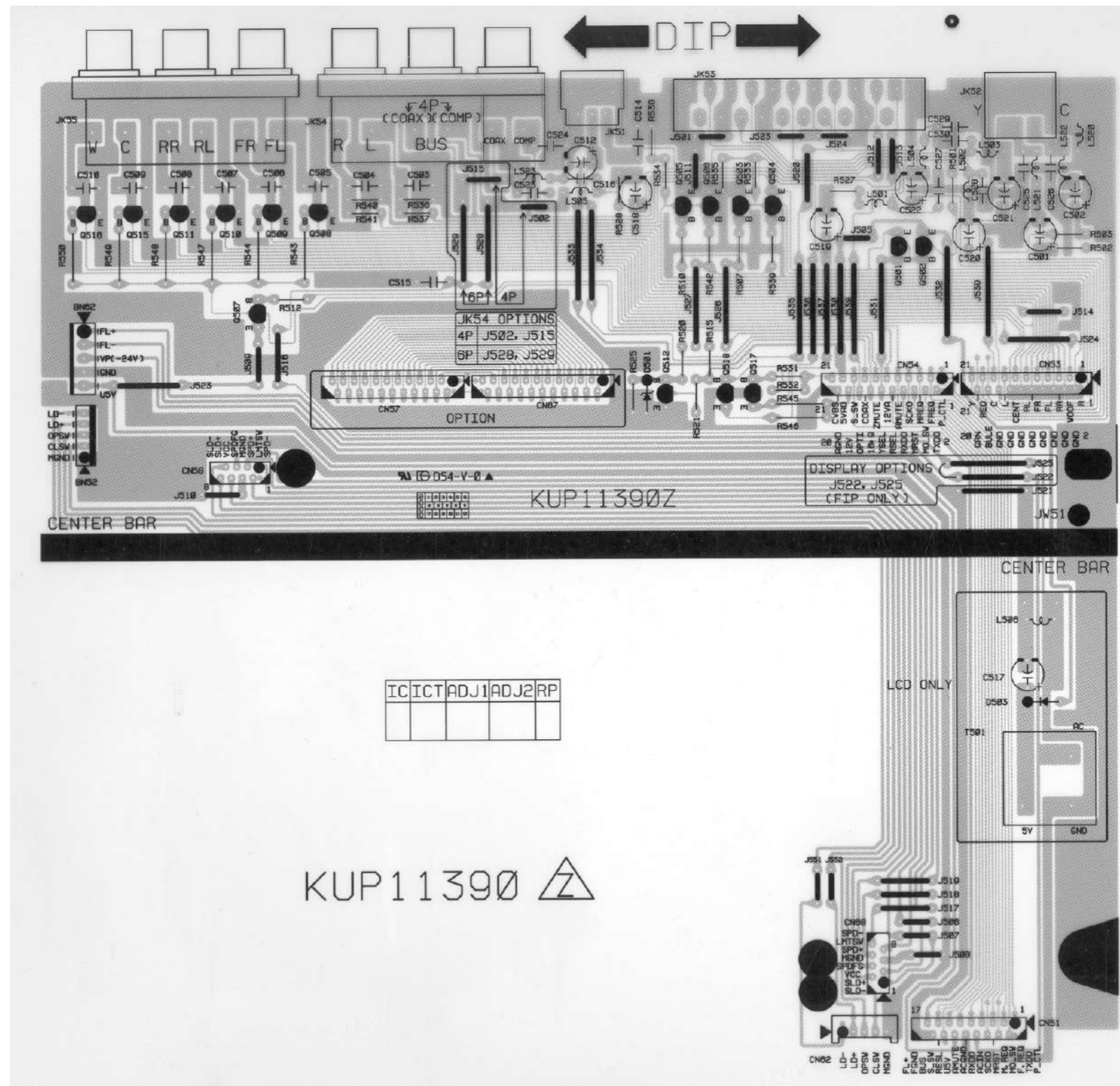

4. FRONT P.C.BOARD

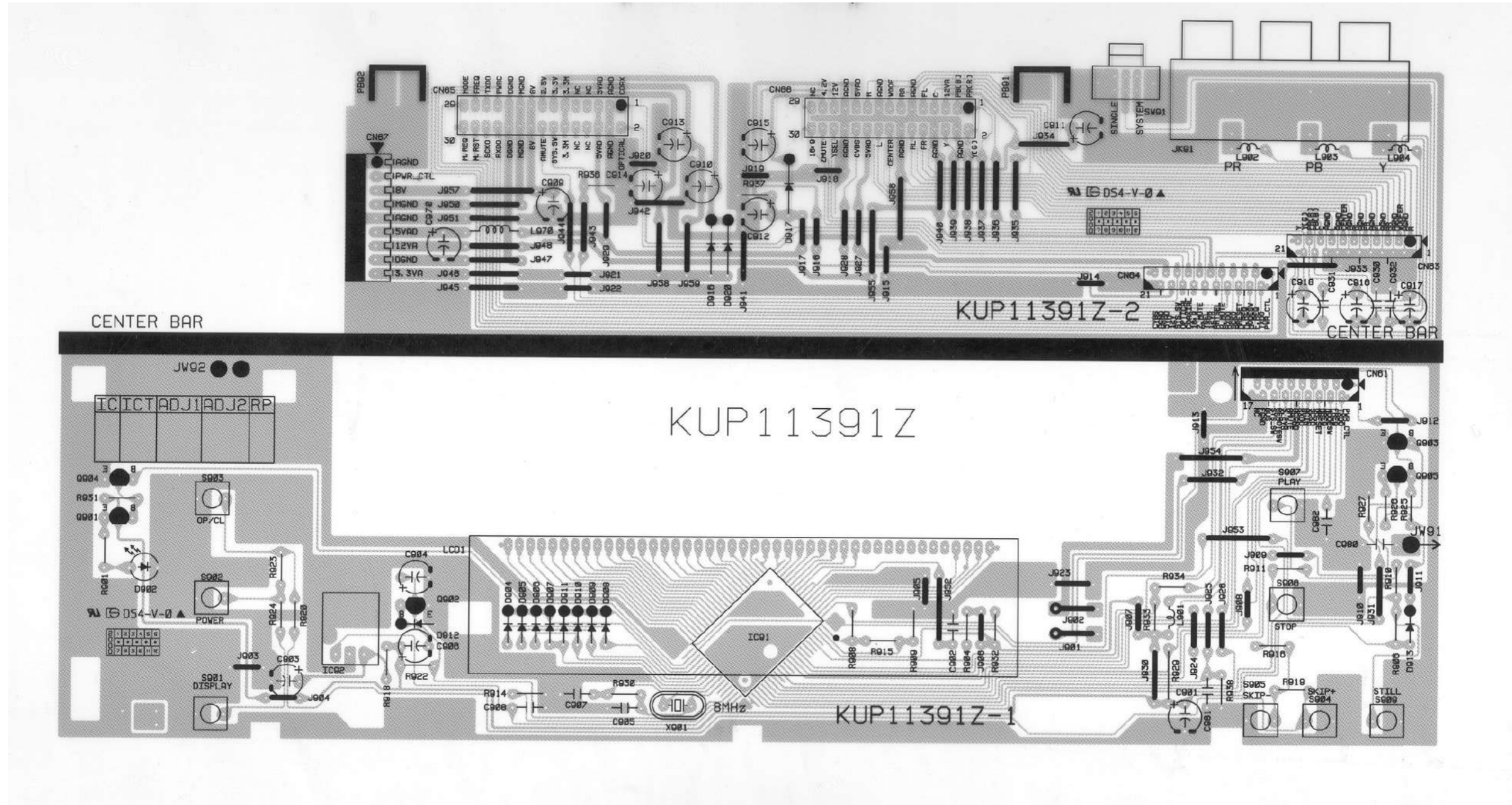

SECTION 3 PARTS LIST

ATTENTION

1. When placing an order for parts, be sure to list the Part No., Model No, and the description of each part. Otherwise, the non-delivery of the part or the delivery of a wrong part may result.
2. Please make sure that Part No. is correct when ordering.
If not, a part different from the one you ordered may be delivered.
3. Since the parts shown in Parts List of Preliminary Service Manual may have been the subject of changes, please use this Parts List for all future reference.

HOW TO USE THIS PARTS LIST

1. This Parts List lists those parts which are considered necessary for repairs. Other common parts, such as resistors and capacitors, are listed in the "Common List for Service Parts" from which these parts should be selected and stocked.
2. Parts not shown in the Parts List and "Common List for Service Parts" will not in principle be supplied.
3. How to read the Parts List.

■ RESISTORS AND CAPACITORS

Notes : • Part numbers are indicated for most mechanical parts.

Please use this part number for parts order.

• **IMPORTANT SAFETY NOTICE.**

Components identified by \triangle mark have special characteristics important for safety.

When replacing any of these components, use only manufacturer's specified parts.

• The unit of resistance is OHM(Ω)

K=1000(Ω), M=1000(K Ω)

• The unit of capacitance is MICROFARED(μ F)

P=10⁻⁶ μ F

■ Numbering System of Resistor

Example

$\frac{\text{KRD}}{\text{Type}} \quad \frac{25}{\text{Wattage}} \quad \frac{\text{F}}{\text{Shape}} \quad \frac{\text{J}}{\text{Tolerance}} \quad \frac{101}{\text{Value}}$

Resistor Type	Wattage	Tolerance
KRD: Carbon	20:1/5W	F:= \pm 1%
KRG: Metal Oxide	25:1/4W	J:= \pm 5%
	50:1/2W	K:= \pm 10%
	1:1W	
KRF: Metal Cement	2:2W	
KRQ: Fusible	3:3W	

■ Numbering System of Capacitor

Example

$\frac{\text{KCKT}}{\text{Type}} \quad \frac{1\text{H}}{\text{Voltage}} \quad \frac{101}{\text{Value}} \quad \frac{\text{K}}{\text{Tolerance}} \quad \frac{\text{B}}{\text{Peculiarity}}$

Capacitor Type	Voltage		Tolerance
	KCEA Type	Others	
KCB: Ceramic	0J:6.3V	1H:50V DC	C: \pm 0.25pF
KCC: Ceramic	1A:10V	1:125V DC	G: \pm 2%
KCK: Ceramic	1C:16V	KC:400V AC	J: \pm 5%
KCQI: Polyester	1E:25V	25 : 250V AC	K: \pm 10%
KCQP: Polypropylene	1H:50V		Z: +80%, -20%
KCQS: Polystyrol	1V:35V		
KCEA: ELECT	2A:100V		
KCFT: Semiconductor			

WARNING

\triangle (*) INDICATES SAFETY CRITICAL COMPONENTS. FOR CONTINUED SAFETY, REPLACE SAFETY CRITICAL COMPONENTS ONLY WITH MANUFACTURE'S RECOMMENDED PARTS.

AVERTISSEMENT

\triangle (*) IL INDIQUE LES COMPOSANTS CRITIQUES DE SÉCURITÉ. POUR MAINTENIR LE DEGRÉ DE SÉCURITÉ DE L'APPAREIL, NE REMPLACER QUE DES PIÈCES RECOMMANDÉES PAR LE FABRICANT.

LOAD No.	PART No.	DESCRIPTION	REMARKS
	KOP11408C	FRONT PCB ASS'Y	DVDL55C
KIP11408C	FRONT PCB AUTO ASS'Y		
	KUP11408Z	PCB , FRONT	247*163
C901	KCEA1CKS470T	CAP , ELECT	47UF 16V
C902	KCBS1H104ZFT	CAP , CERAMIC	0.1UF 50V Z
C903	KCEA1CKS470T	CAP , ELECT	47UF 16V
C904	KCEA1CKS100T	CAP , ELECT	10UF 16V
C906	KCEA1HKS1R0T	CAP , ELECT	1UF 50V
C908	KCBS1H102KBT	CAP , CERAMIC	1000PF 50V K
C909 ~ C914	KCEA1CKS101T	CAP , ELECT	100UF 16V
C919 , C920	KCBS1H104ZFT	CAP , CERAMIC	0.1UF 50V Z
C921	KCEA1HKS1R0T	CAP , ELECT	1UF 50V
D902	BVDSEL2E10CFT	L.E.D , BLUE	
D904 , D912	KVD1N4148MT	DIODE	1N4148
D916	KVD1N4003ST	DIODE	1N4003
IC91	BVIANAM1318DVD	IC , MICOM	LC866412A-5S47
L901	KLQ02C100KT	COIL , AXIAL	10UH , K
Q901 , Q902	KVTKRC107MT	T.R	KRC107M
Q904	KVTKRC107MT	T.R	KRC107M
R901	KRD20TJ221T	RES , CARBON	220 OHM 1/5W J
R902 , R904	KRD20TJ103T	RES , CARBON	10K OHM 1/5W J
R906	KRD20TJ103T	RES , CARBON	10K OHM 1/5W J
R909	KRD20TJ681T	RES , CARBON	680 OHM 1/5W J
R910	KRD20TJ821T	RES , CARBON	820 OHM 1/5W J
R911	KRD20TJ122T	RES , CARBON	1.2K OHM 1/5W J
R912	KRD20TJ103T	RES , CARBON	10K OHM 1/5W J
R916	KRD20TJ152T	RES , CARBON	1.5K OHM 1/5W J
R919	KRD20TJ222T	RES , CARBON	2.2K OHM 1/5W J
R922	KRD20TJ472T	RES , CARBON	4.7K OHM 1/5W J
R924	KRD20TJ822T	RES , CARBON	8.2K OHM 1/5W J
R925 , R926	KRD20TJ103T	RES , CARBON	10K OHM 1/5W J
R927	KRD20TJ473T	RES , CARBON	47K OHM 1/5W J
R929	KRD20TJ103T	RES , CARBON	10K OHM 1/5W J
R931	KRD20TJ331T	RES , CARBON	330 OHM 1/5W J
R936	KRD20TJ473T	RES , CARBON	47K OHM 1/5W J
R938	KRD20TJ103T	RES , CARBON	10K OHM 1/5W J
R940	KRD20TJ102T	RES , CARBON	1K OHM 1/5W J
S902 ~ S907	KST1A012ZT	SW , TACT	SKHV10910G
S909	KST1A012ZT	SW , TACT	SKHV10910G
BK93	KMD1A387	BRACKET , PCB	
BN68	KWB1D909120LM	WIRE ASS'Y	
CN61	KJP17GB113ZG	WAFER , CARD CABLE"	
CN63 , CN64	KJP21GA117ZG	WAFER , CARD CABLE (21P 1M/	GF102-21S-TS
CN65 , CN66	KJP30HA129ZP	CONNECTOR FLUG, FLOATING	
F901	KFLHNV07SM08T	FIP DISPLAY	HNV-07SM08T
IC92	KRVHIM602H32	SENSOR , REMOCON	
PB91 , PB92	KMD1A374	BRACKET , FLT	
X901	BVFCST600MGW	RESONATOR , CERAMIC	CST6.00MGW
	KWC1B2A17A150B	CARD CABLE	
	KOP11390E	SUB PCB ASS'Y	DVD-L55C
	KIP11390E	SUB PCB AUTO ASS'Y	DVD-L55C
	KUP11390Z	PCB , SUB	197 * 197
C501 , C502	KCEA1CH471T	CAP , ELECT	470UF 16V

LOAD No.	PART No.	DESCRIPTION	REMARKS
C503 , C504	KCBS1H101KBT	CAP , CERAMIC	100PF 50V K
C512	KCEA1CH470T	CAP , ELECT	47UF 16V
C514	KCBS1H100JCT	CAP , CERAMIC	10PF 50V J
C516	KCBS1H103ZFT	CAP , CERAMIC	0.01UF 50V Z
C518 ~ C522	KCEA1CH471T	CAP , ELECT	470UF 16V
C523	KCBS1H100JCT	CAP , CERAMIC	10PF 50V J
C524	KCBS1C152MXT	CAP , CERAMIC	1500PF 16V M
C525 , C526	KCBS1H681KBT	CAP , CERAMIC	680PF 50V K
C527	KCBS1C152MXT	CAP , CERAMIC	1500PF 16V M
C528 ~ C530	KCBS1H681KBT	CAP , CERAMIC	680PF 50V K
D501	KVDMTZJ5.1BT	DIODE , ZENER	5.1V 1/2W
L501 ~ L505	KLQ02C1R8KT	COIL	1.8UH , K
L521 ~ L523	KLQ02C1R8KT	COIL	1.8UH , K
Q501	KVTKRC107MT	T.R	KRC107M
Q502	KVTKTA1266YT	T.R	KTA1266Y
Q503 ~ Q506	KVTKTD1302T	T.R	KTD1302T
Q507	KVTKTA1266YT	T.R	KTA1266Y
Q512	KVTKTC3198YT	T.R	KTC3198Y
Q517 , Q518	KVTKTA1266YT	T.R	KTA1266Y
R501	KRD20TJ750T	RES , CARBON	75 OHM 1/5W J
R502	KRD20TJ470T	RES , CARBON	47 OHM 1/5W J
R503	KRD20TJ560T	RES , CARBON	56 OHM 1/5W J
R507 , R510	KRD20TJ102T	RES , CARBON	1K OHM 1/5W J
R512 , R515	KRD20TJ102T	RES , CARBON	1K OHM 1/5W J
R520	KRD20TJ222T	RES , CARBON	2.2K OHM 1/5W J
R521	KRD20TJ821T	RES , CARBON	820 OHM 1/5W J
R525	KRD20TJ222T	RES , CARBON	2.2K OHM 1/5W J
R527 , R528	KRD20TJ560T	RES , CARBON	56 OHM 1/5W J
R531 , R532	KRD20TJ101T	RES , CARBON	100 OHM 1/5W J
R533 , R534	KRD20TJ221T	RES , CARBON	220 OHM 1/5W J
R535 , R536	KRD20TJ104T	RES , CARBON	100K OHM 1/5W J
R537	KRD20TJ221T	RES , CARBON	220 OHM 1/5W J
R538	KRD20TJ104T	RES , CARBON	100K OHM 1/5W J
R539	KRD20TJ102T	RES , CARBON	1K OHM 1/5W J
R540	KRD20TJ104T	RES , CARBON	100K OHM 1/5W J
R541	KRD20TJ221T	RES , CARBON	220 OHM 1/5W J
R542	KRD20TJ102T	RES , CARBON	1K OHM 1/5W J
R545 , R546	KRD25TJ681T	RES , CARBON	680 OHM 1/4W J
BN52	KWB2B905150GN	WIRE ASS'Y	
BN62	KWB1D905120LM	WIRE ASS'Y	
CN51	KJP17GA117ZG	WAFER , CARD CABLE	
CN53 , CN54	KJP21GA117ZG	WAFER , CARD CABLE (21P 1M/	GF102-21S-TS
CN58	KJP08GA117ZG	WAFER , CARD	8P 1M/M
CN62	KJP05GA47ZG	WAFER	GIL-S-5P-S2T2EF
CN68	KJP08GA117ZG	WAFER , CARD	8P 1M/M
JK51	BJS9L001Z	MODULE , OPTICAL (TX)	
JK52	KJJ9M001Z	JACK , S-VIDEO (1P/H)	
JK53	KJP21GA118ZP	SCART CONNECTOR	
JK54	KJJ4P037Z	JACK , BOARD	
JW51	KWE7202120RV	WIRE ASS'Y	
	KOP11394C	MAIN PCB ASS'Y (LGE)	6881R-2200B
	6870R2090AM PWB(PCB)	SDMG311PDM ANAM EPOXY FR-4 2LA	

LOAD No.	PART No.	DESCRIPTION	REMARKS
IC501	0IH641703B	IC , HITACHI	HD6417034AFI20 112QFP BK MICOM
IC503	0IEB114162A	IC , ELITE MEMORY	TECH M11B416256A-35J ELITE 4M(256K
X501	6212S-AMLCB	RESONATOR	CSTCV20.00MXJ040-TC20 MURATA 2
L501 , L506	6200HJC102A	FILTER(CIRC) , EMI	HB-1M2012-102JT CERATECH TP 3K
R507 , R508	0RH0000C622	RESISTOR , CHIP	0 1/16W 5 D.R/TP
R573	0RH0000C622	RESISTOR , CHIP	0 1/16W 5 D.R/TP
R592	0RH0000D622	RESISTOR , CHIP	0 1/10W 5 D.R/TP
R5A6 , R5A7	0RH0000D622	RESISTOR , CHIP	0 1/10W 5 D.R/TP
R564	0RH1001C622	RESISTOR , METAL	1KOHM 1 / 16 W 1608 5.00% D
R535 ~ R537	0RH1002C622	RESISTOR , CHIP	10K 1/16W 5 D.R/TP
R569 , R583	0RH1201C622	RESISTOR , CHIP	1.2K 1/16W 5 D.R/TP
R584 , R588	0RH1201C622	RESISTOR , CHIP	1.2K 1/16W 5 D.R/TP
R593	0RH1201C622	RESISTOR , CHIP	1.2K 1/16W 5 D.R/TP
R571	0RH4702C622	RESISTOR , CHIP	47K 1/16W 5 D.R/TP
C515 , C517	0CH1225F944	CAPACITOR , FIXED	CERA 2UF 16V 80%,-20% Y5V(F) 3216 R
C506 , C507	0CH1104K942	CAPACITOR , CHIP	[CERAM 0.1UF 50V Z Y5V(F) 1508 R/TP
C514	0CH1104K942	CAPACITOR , CHIP	[CERAM 0.1UF 50V Z Y5V(F) 1508 R/TP
C535	0CH1104K942	CAPACITOR , CHIP	[CERAM 0.1UF 50V Z Y5V(F) 1508 R/TP
C523 , C525	0CH4221K412	CAPACITOR , CHIP	[CERAM 220P 50V J COG 1.6X0.8 R/TP
C526 , C529	0CH4221K412	CAPACITOR , CHIP	[CERAM 220P 50V J COG 1.6X0.8 R/TP
C531 , C532	0CH4221K412	CAPACITOR , CHIP	[CERAM 220P 50V J COG 1.6X0.8 R/TP
PMD03	6630R-FB02H	CONNECTOR (CIRC) , FFC	04-6232-108-008-800 ELCO 8PIN
IC2A1	0ITI333721A	IC , TI	INSTRUMENT SSI33P3721(VER2)64 TQFP BK R
IC2A2	0IJR341400C	IC , JRC	NJM3414AM-TE1,3K/REEL. JRC
Q2A1 , Q2A2	0TR103709BB	TRANSISTOR	2SA1037K-Q CHIP ROHM-J
D2A1 , D2A2	0DS202009CA	DIODE , SWITCHING	DAN202K TP ROHM KOREA SOT23 80
L204	6200HJC102A	FILTER(CIRC) , EMI	HB-1M2012-102JT CERATECH TP 3K
R217	0RH0102C622	RESISTOR , CHIP	10 1/16W 5 D.R/TP
R2B4 , R2B5	0RH0182C622	RESISTOR , CHIP	18 1/16W 5 D.R/TP
R2C8 , R2C9	0RH0182C622	RESISTOR , CHIP	18 1/16W 5 D.R/TP
R275 , R276	0RH9100C622	RESISTOR , CHIP	910 OHM 1 / 16 W 1608 5% D R/T
R230 ~ R237	0RH1000C622	RESISTOR , CHIP	100 1/16W 5 D.R/TP
R2C4	0RH1000C622	RESISTOR , CHIP	100 1/16W 5 D.R/TP
R277	0RH1500C622	RESISTOR , CHIP	150 1/16W 5 D.R/TP
R218	0RH4700C622	RESISTOR , CHIP	470 1/16W 5 D.R/TP
R274	0RH6200C622	RESISTOR , CHIP	620 OHM 1 / 16 W 1608 5% D R/T
R2P8	0RH1201C622	RESISTOR , CHIP	1.2K 1/16W 5 D.R/TP
R2A2	0RH1202C622	RESISTOR , CHIP	12K 1/16W 5 D.R/TP
R2P7	0RH2202C622	RESISTOR , CHIP	22K 1/16W 5 D.R/TP
R2C0	0RH3902C622	RESISTOR , CHIP	39K 1/16W J D.R/TP
R2C1	0RH3902C622	RESISTOR , CHIP	39K 1/16W J D.R/TP
R2B8 , R2B9	0RH1503C622	RESISTOR , CHIP	150K 1/16W 5 D.R/TP
C260	0CH4100K112	CHIP CAPA	CERAMIC M/ 10P 50V D COG 1.6X0.8 R/TP
C2C8 , C2C9	0CH4330K412	CAPACITOR , CHIP	[CERAM 33P 50V J COG 1.6X0.8 R/TP
C2B4 , C2B5	0CH4561K512	CAPACITOR , CHIP	[CERAM 560PF 50V K NP0 1608 R/TP
C2N3	0CH1223K942	CAPACITOR , CHIP	[CERAM 0.022UF 50V Z Y5V(F) 1508 R/TP
C2B3	0CHZS-0001F	CAPACITOR , CHIP	GRM39Y5V473Z25C500 PT266 MURAT
C2N4	0CH1225F944	CAPACITOR , FIXED	CERA 2UF 16V 80%,-20% Y5V(F) 3216 R
C271	0CH7106C611	CAPA , CHIP	TANTALUM 10UF 6.3V M 3216 TP(-)
C278 ~ C281	0CH7106C611	CAPA , CHIP	TANTALUM 10UF 6.3V M 3216 TP(-)
C2D5	0CH7106C611	CAPA , CHIP	TANTALUM 10UF 6.3V M 3216 TP(-)
C272 , C274	0CH8476C611	CAPACITOR , CHIP	[AL. E 47UF 6.3V M 85STD(CYL) R/TP
C284	0CH8476C611	CAPACITOR , CHIP	[AL. E 47UF 6.3V M 85STD(CYL) R/TP
C2D1 ~ C2D4	0CH8476C611	CAPACITOR , CHIP	[AL. E 47UF 6.3V M 85STD(CYL) R/TP

LOAD No.	PART No.	DESCRIPTION	REMARKS
C2M1	0CH8107F611	CAPACITOR , CHIP	[AL. E 100UF 16V M 85STD(CYL) R/TP
R2A1 , R2D6	0RH0912C622	RESISTOR , CHIP	91 OHM 1 / 16 W 1608 5% D R/TP
R2D7	0RH0472C622	RESISTOR , CHIP	47 1/16W 5 D.R/TP
R2A6 , R2B3	0RH1001C622	RESISTOR , METAL	1KOHM 1 / 16 W 1608 5.00% D
R2C2 , R2C3	0RH1001C622	RESISTOR , METAL	1KOHM 1 / 16 W 1608 5.00% D
R2D0	0RH1001C622	RESISTOR , METAL	1KOHM 1 / 16 W 1608 5.00% D
PMD04	6630R3S006F	CONNECTOR (CIRC)	GT200 LG CABLE 5PIN 2MM STRAIG
R201 ~ R204	0RH0000C622	RESISTOR , CHIP	0 1/16W 5 D.R/TP
R239 ~ R242	0RH0000C622	RESISTOR , CHIP	0 1/16W 5 D.R/TP
R244 , R278	0RH0000C622	RESISTOR , CHIP	0 1/16W 5 D.R/TP
R279 , R2A5	0RH0000C622	RESISTOR , CHIP	0 1/16W 5 D.R/TP
R2A9 , R2B2	0RH0000C622	RESISTOR , CHIP	0 1/16W 5 D.R/TP
R2C6 , R2C7	0RH0000C622	RESISTOR , CHIP	0 1/16W 5 D.R/TP
R2D1 , R2D4	0RH0000C622	RESISTOR , CHIP	0 1/16W 5 D.R/TP
R2D5 , R2E6	0RH0000C622	RESISTOR , CHIP	0 1/16W 5 D.R/TP
C240 , C2A2	0CH1222K562	CAPACITOR , CHIP	[CERAM 2200PF 50V K X7R(X) 1608 R/TP
C2C1 ~ C2C3	0CH1222K562	CAPACITOR , CHIP	[CERAM 2200PF 50V K X7R(X) 1608 R/TP
C201 , C224	0CH1104K942	CAPACITOR , CHIP	[CERAM 0.1UF 50V Z Y5V(F) 1508 R/TP
C226 ~ C228	0CH1104K942	CAPACITOR , CHIP	[CERAM 0.1UF 50V Z Y5V(F) 1508 R/TP
C238 , C239	0CH1104K942	CAPACITOR , CHIP	[CERAM 0.1UF 50V Z Y5V(F) 1508 R/TP
C242 , C245	0CH1104K942	CAPACITOR , CHIP	[CERAM 0.1UF 50V Z Y5V(F) 1508 R/TP
C255 , C2A0	0CH1104K942	CAPACITOR , CHIP	[CERAM 0.1UF 50V Z Y5V(F) 1508 R/TP
C2A1 , C2A3	0CH1104K942	CAPACITOR , CHIP	[CERAM 0.1UF 50V Z Y5V(F) 1508 R/TP
C2A5 , C2A8	0CH1104K942	CAPACITOR , CHIP	[CERAM 0.1UF 50V Z Y5V(F) 1508 R/TP
C2B8 , C2B9	0CH1104K942	CAPACITOR , CHIP	[CERAM 0.1UF 50V Z Y5V(F) 1508 R/TP
C2C5 , C2D0	0CH1104K942	CAPACITOR , CHIP	[CERAM 0.1UF 50V Z Y5V(F) 1508 R/TP
C2D6 , C2D7	0CH1104K942	CAPACITOR , CHIP	[CERAM 0.1UF 50V Z Y5V(F) 1508 R/TP
C2M8	0CH1104K942	CAPACITOR , CHIP	[CERAM 0.1UF 50V Z Y5V(F) 1508 R/TP
R219 , R220	0RH1002C622	RESISTOR , CHIP	10K 1/16W 5 D.R/TP
R2A0 , R2N8	0RH1002C622	RESISTOR , CHIP	10K 1/16W 5 D.R/TP
R2Q1	0RH1002C622	RESISTOR , CHIP	10K 1/16W 5 D.R/TP
IC201	0IHY258010C	IC , HYUNDAI	GDC25D801D 208 QFP BK DSP+SERV
PMD02	6630R-FB02W	CONNECTOR (CIRC) , FFC	04-6232-123-008-800 ELCO 23PIN
IC301	0ICU410000A	IC , C-CUBE	ZIVA4.1 QFP BK MPEG DECORDER
IC302	0IGS721616C	IC , LG SEMICONDUCTOR	GM72V161621ET-7 50TSOP TP 16MS
IC371	0ISH205000A	IC , SHARP	PQ20WZ5U 20WZ51 TP REGULATOR V
X301	6202R-BL01A	CRYSTAL , SMD	-49/SM5H KONY CHIP 27MHZ 20P
L306	6200HJC102A	FILTER(CIRC) , EMI	HB-1M2012-102JT CERATECH TP 3K
R351	0RH0000C622	RESISTOR , CHIP	0 1/16W 5 D.R/TP
R3K1	0RH0000C622	RESISTOR , CHIP	0 1/16W 5 D.R/TP
R315 ~ R322	0RH0332C622	RESISTOR , CHIP	33 1/16W 5 D.R/TP
R326	0RH0332C622	RESISTOR , CHIP	33 1/16W 5 D.R/TP
R334 , R335	0RH1000C622	RESISTOR , CHIP	100 1/16W 5 D.R/TP
R302	0RH1001C622	RESISTOR , METAL	1KOHM 1 / 16 W 1608 5.00% D
R306 , R307	0RH1002C622	RESISTOR , CHIP	10K 1/16W 5 D.R/TP
R309 , R311	0RH1002C622	RESISTOR , CHIP	10K 1/16W 5 D.R/TP
R313 , R371	0RH1002C622	RESISTOR , CHIP	10K 1/16W 5 D.R/TP
R340	0RH1181C422	RESISTOR , CHIP	1.18K OHM 1 / 16 W 1608 1% D R
R373	0RH3901C622	RESISTOR , CHIP	3.9K 1/16W 5 D.R/TP
R303	0RH4701C622	RESISTOR , CHIP	4.7K 1/16W 5 D.R/TP
R372	0RH7501C622	RESISTOR , CHIP	7.5K 1/16W 5 D.R/TP
C335 , C336	0CH1104K942	CAPACITOR , CHIP	[CERAM 0.1UF 50V Z Y5V(F) 1508 R/TP
C371 , C380	0CH1104K942	CAPACITOR , CHIP	[CERAM 0.1UF 50V Z Y5V(F) 1508 R/TP
C375	0CH8107F611	CAPACITOR , CHIP	[AL. E 100UF 16V M 85STD(CYL) R/TP

LOAD No.	PART No.	DESCRIPTION	REMARKS
C343 , C344	0CH4220K412	CAPA , CHIP	CERAMIC M/ 22P 50V J COG 1.6X0.8 R/TP
C382 ~ C384	0CH8476C611	CAPACITOR , CHIP	[AL. E 47UF 6.3V M 85STD(CYL) R/TP
IC402	0IBB213400A	IC , BURR BROWN	OPA2134 8P SOP R/TP OP AMP
IC404	0ISH205000A	IC , SHARP	PQ20WZ5U 20WZ51 TP REGULATOR V
IC403	GITO704000F	IC , TOSHIBA	TC7W04FU
Q404	0TR100009BM	TRANSISTOR	UMZ1N TL UM6 3K TP ROHM
Q401	0TR150509AD	TRANSISTOR	KTA1505S-Y -T1 TP KEC SOT23
R419	0RH1000C622	RESISTOR , CHIP	100 1/16W 5 D.R/TP
R418	0RH1001C622	RESISTOR , METAL	1KOHM 1 / 16 W 1608 5.00% D
R439	0RH1002C622	RESISTOR , CHIP	10K 1/16W 5 D.R/TP
R429	0RH0562C622	RESISTOR , CHIP	56 1/16W 5 D.R/TP
R413 , R416	0RH1502C622	RESISTOR , CHIP	15K 1/16W 5 D.R/TP
R426 , R428	0RH2200C622	RESISTOR , CHIP	220 1/16W 5 D.R/TP
R408 , R437	0RH2201C622	RESISTOR , CHIP	2.2K 1/16W 5 D.R/TP
R425 , R427	0RH3300C622	RESISTOR , CHIP	330 1/16W 5 D.R/TP
R403 ~ R406	0RH4700C622	RESISTOR , CHIP	470 1/16W 5 D.R/TP
R415	0RH4701C622	RESISTOR , CHIP	4.7K 1/16W 5 D.R/TP
R414	0RH5601C622	RESISTOR , CHIP	5.6K 1/16W 5 D.R/TP
R412 , R417	0RH6801C622	RESISTOR , CHIP	6.8K 1/16W 5 D.R/TP
R438	0RH7501C622	RESISTOR , CHIP	7.5K 1/16W 5 D.R/TP
C524 , C527	0CH4221K412	CAPACITOR , CHIP	[CERAM 220P 50V J COG 1.6X0.8 R/TP
L502 , L503	6200HJC102A	FILTER(CIRC) , EMI	HB-1M2012-102JT CERATECH TP 3K
L505 , L507	6200HJC102A	FILTER(CIRC) , EMI	HB-1M2012-102JT CERATECH TP 3K
R596	0RH0000D622	RESISTOR , CHIP	0 1/10W 5 D.R/TP
R5A1 ~ R5A5	0RH0000D622	RESISTOR , CHIP	0 1/10W 5 D.R/TP
R5A8	0RH0000D622	RESISTOR , CHIP	0 1/10W 5 D.R/TP
R503 , R565	0RH4702C622	RESISTOR , CHIP	47K 1/16W 5 D.R/TP
R576 , R577	0RH4702C622	RESISTOR , CHIP	47K 1/16W 5 D.R/TP
IC504	0ISS241610B	IC , SAMSUNG	ELECTRONIKS24L161CS 8P SOP TP EEPROM 16
C536	0CH7106F621	CAPACITOR , CHIP	[TANTA 10UF 16V M 3528MM TP(-)
R505	0RH6802C622	RESISTOR , CHIP	68K 1/16W 5 D.R/TP
C505	0CH7106C611	CAPA , CHIP	TANTALUM 10UF 6.3V M 3216 TP(-)
IC204	DITO453000C	IC , TOSHIBA	TC4W53FU SSOP 8PIN
Q2M1 ~ Q2M3	0TR103009AA	TRANSISTOR	CHIP KRC103S-T1(NC)22-22 KEC
R271 , R273	0RH0000C622	RESISTOR , CHIP	0 1/16W 5 D.R/TP
R280	0RH0000C622	RESISTOR , CHIP	0 1/16W 5 D.R/TP
R294 , R296	0RH1500C622	RESISTOR , CHIP	150 1/16W 5 D.R/TP
R292 , R297	0RH1201C622	RESISTOR , CHIP	1.2K 1/16W 5 D.R/TP
R293 , R295	0RH2001C622	RESISTOR , CHIP	2K OHM 1 / 16 W 1608 5% D R/TP
R2M7 , R2N2	0RH5601C622	RESISTOR , CHIP	5.6K 1/16W 5 D.R/TP
R2N0 , R2N5	0RH1202C622	RESISTOR , CHIP	12K 1/16W 5 D.R/TP
R2N4	0RH1502C622	RESISTOR , CHIP	15K 1/16W 5 D.R/TP
C2C0	0CH4221K412	CAPACITOR , CHIP	[CERAM 220P 50V J COG 1.6X0.8 R/TP
C2C4	0CH1222K562	CAPACITOR , CHIP	[CERAM 2200PF 50V K X7R(X) 1608 R/TP
C2M3	0CH1472K562	CAPACITOR , CHIP	[CERAM 4700PF 50V K X7R(X) 1608 R/TP
C2M2	0CH1682K562	CAPACITOR , CHIP	[CERAM 6800P 50V K X7R 1.6X0.8 R/TP
C2N2	0CHZS-0001B	CAPACITOR , CHIP	GRM39X7R103K50C500 PT266 MURAT
C2B6	0CH1333K562	CAPACITOR , CHIP	[CERAM 0.033UF 50V K X7R(X) 1508 R/TP
C2B7	0CH1333K562	CAPACITOR , CHIP	[CERAM 0.033UF 50V K X7R(X) 1508 R/TP
C270 , C273	0CH1225F944	CAPACITOR , FIXED	CERA 2UF 16V 80%,-20% Y5V(F) 3216 R
C277	0CH1225F944	CAPACITOR , FIXED	CERA 2UF 16V 80%,-20% Y5V(F) 3216 R
C232 , C275	0CH7106C611	CAPA , CHIP	TANTALUM 10UF 6.3V M 3216 TP(-)
C276	0CH7106C611	CAPA , CHIP	TANTALUM 10UF 6.3V M 3216 TP(-)
IC2M1	0IFA303200A	IC , FAIRCHILD	KA3032 48QFP BK 5CH MOTOR DRIV

LOAD No.	PART No.	DESCRIPTION	REMARKS
R2P4	0RH1802C622	RESISTOR , CHIP	18K 1/16W 5 D.R/TP
R2M1 , R2M5	0RH1001C622	RESISTOR , METAL	1KOHM 1 / 16 W 1608 5.00% D
R2M8 , R2N1	0RH1001C622	RESISTOR , METAL	1KOHM 1 / 16 W 1608 5.00% D
R2N6 , R2N7	0RH1001C622	RESISTOR , METAL	1KOHM 1 / 16 W 1608 5.00% D
R2P6	0RH1001C622	RESISTOR , METAL	1KOHM 1 / 16 W 1608 5.00% D
R281	0RH2201C622	RESISTOR , CHIP	2.2K 1/16W 5 D.R/TP
IC203	0IJR341400C	IC , JRC	NJM3414AM-TE1,3K/REEL. JRC
IC205	0IGL440164C	IC , G-LINK	GLT440L16-40J4 40P SOJ TP 4M(2
C2E1	0CH1392K562	CAPACITOR , CHIP	[CERAM 3900PF 50V K Z5U(E) 1608 R/TP
L201 ~ L203	6200HJC102A	FILTER(CIRC) , EMI	HB-1M2012-102JT CERATECH TP 3K
L207 , L208	6200HJC102A	FILTER(CIRC) , EMI	HB-1M2012-102JT CERATECH TP 3K
L211 , L2A1	6200HJC102A	FILTER(CIRC) , EMI	HB-1M2012-102JT CERATECH TP 3K
L2A2	6200HJC102A	FILTER(CIRC) , EMI	HB-1M2012-102JT CERATECH TP 3K
R221	0RH1002C622	RESISTOR , CHIP	10K 1/16W 5 D.R/TP
R2B6	0RH1002C622	RESISTOR , CHIP	10K 1/16W 5 D.R/TP
R2M2 , R2M6	0RH1002C622	RESISTOR , CHIP	10K 1/16W 5 D.R/TP
R2M9 , R2N3	0RH1002C622	RESISTOR , CHIP	10K 1/16W 5 D.R/TP
R2N9 , R2P1	0RH1002C622	RESISTOR , CHIP	10K 1/16W 5 D.R/TP
R2P2 , R2P3	0RH1002C622	RESISTOR , CHIP	10K 1/16W 5 D.R/TP
R2P5	0RH1002C622	RESISTOR , CHIP	10K 1/16W 5 D.R/TP
C203	0CH1104K942	CAPACITOR , CHIP	[CERAM 0.1UF 50V Z Y5V(F) 1508 R/TP
C205 ~ C207	0CH1104K942	CAPACITOR , CHIP	[CERAM 0.1UF 50V Z Y5V(F) 1508 R/TP
C210 , C221	0CH1104K942	CAPACITOR , CHIP	[CERAM 0.1UF 50V Z Y5V(F) 1508 R/TP
C223 , C229	0CH1104K942	CAPACITOR , CHIP	[CERAM 0.1UF 50V Z Y5V(F) 1508 R/TP
C237 , C241	0CH1104K942	CAPACITOR , CHIP	[CERAM 0.1UF 50V Z Y5V(F) 1508 R/TP
C250	0CH1104K942	CAPACITOR , CHIP	[CERAM 0.1UF 50V Z Y5V(F) 1508 R/TP
C256 ~ C258	0CH1104K942	CAPACITOR , CHIP	[CERAM 0.1UF 50V Z Y5V(F) 1508 R/TP
C285 , C2A4	0CH1104K942	CAPACITOR , CHIP	[CERAM 0.1UF 50V Z Y5V(F) 1508 R/TP
C2A6 , C2A7	0CH1104K942	CAPACITOR , CHIP	[CERAM 0.1UF 50V Z Y5V(F) 1508 R/TP
C2A9	0CH1104K942	CAPACITOR , CHIP	[CERAM 0.1UF 50V Z Y5V(F) 1508 R/TP
C2B0 ~ C2B2	0CH1104K942	CAPACITOR , CHIP	[CERAM 0.1UF 50V Z Y5V(F) 1508 R/TP
C2D9	0CH1104K942	CAPACITOR , CHIP	[CERAM 0.1UF 50V Z Y5V(F) 1508 R/TP
C2M4 ~ C2M7	0CH1104K942	CAPACITOR , CHIP	[CERAM 0.1UF 50V Z Y5V(F) 1508 R/TP
C2M9	0CH1104K942	CAPACITOR , CHIP	[CERAM 0.1UF 50V Z Y5V(F) 1508 R/TP
C2N1	0CH1104K942	CAPACITOR , CHIP	[CERAM 0.1UF 50V Z Y5V(F) 1508 R/TP
R2M3	0RH7501C622	RESISTOR , CHIP	7.5K 1/16W 5 D.R/TP
R2B7 , R2E7	0RH3301C622	RESISTOR , CHIP	3.3K 1/16W 5 D.R/TP
IC304	0IBB170000A	IC , BURR BROWN	PLL1700E 20P SSOP TP PHASE LOC
IC303	0IGS721616C	IC , LG SEMICONDUCTOR	GM72V161621ET-7 50TSOP TP 16MS
IC372	0ISA713500A	IC , SANYO	LA7135A SOP24 TP S/W
P3901	6630R-BE034	CONNECTOR (CIRC) , BOA	2254-30S-T ILLSSAN 30PIN 2.0MM
Q301 ~ Q305	0TR150409BF	TRANSISTOR	KTA1504S-Y TP (RTK:3K/REEL).KE
Q371	0TR387509AC	TRANSISTOR	CHIP KTC3875S-GR-T1(ALG) KEC
Q372	0TR387509AC	TRANSISTOR	CHIP KTC3875S-GR-T1(ALG) KEC
Q373	0TR387509AC	TRANSISTOR	CHIP KTC3875S-GR-T1(ALG) KEC
L301 ~ L308	6200HJC102A	FILTER(CIRC) , EMI	HB-1M2012-102JT CERATECH TP 3K
L371	6200HJC102A	FILTER(CIRC) , EMI	HB-1M2012-102JT CERATECH TP 3K
R350	0RH0000C622	RESISTOR , CHIP	0 1/16W 5 D.R/TP
R323 ~ R333	0RH0332C622	RESISTOR , CHIP	33 1/16W 5 D.R/TP
R336 ~ R339	0RH0752C622	RESISTOR , CHIP	75 1/16W 5 D.R/TP
R342 ~ R349	0RH1000C622	RESISTOR , CHIP	100 1/16W 5 D.R/TP
R341 , R353	0RH1001C622	RESISTOR , METAL	1KOHM 1 / 16 W 1608 5.00% D
R356 ~ R358	0RH1001C622	RESISTOR , METAL	1KOHM 1 / 16 W 1608 5.00% D
R377 ~ R379	0RH1001C622	RESISTOR , METAL	1KOHM 1 / 16 W 1608 5.00% D

LOAD No.	PART No.	DESCRIPTION	REMARKS
R301 , R308	0RH1002C622	RESISTOR , CHIP	10K 1/16W 5 D.R/TP
R310 , R312	0RH1002C622	RESISTOR , CHIP	10K 1/16W 5 D.R/TP
R314 , R355	0RH1002C622	RESISTOR , CHIP	10K 1/16W 5 D.R/TP
R354	0RH2201C622	RESISTOR , CHIP	2.2K 1/16W 5 D.R/TP
C303 ~ C324	0CH1104K942	CAPACITOR , CHIP	[CERAM 0.1UF 50V Z Y5V(F) 1508 R/TP
C326 , C329	0CH1104K942	CAPACITOR , CHIP	[CERAM 0.1UF 50V Z Y5V(F) 1508 R/TP
C330 ~ C334	0CH1104K942	CAPACITOR , CHIP	[CERAM 0.1UF 50V Z Y5V(F) 1508 R/TP
C337 ~ C339	0CH1104K942	CAPACITOR , CHIP	[CERAM 0.1UF 50V Z Y5V(F) 1508 R/TP
C341 , C342	0CH1104K942	CAPACITOR , CHIP	[CERAM 0.1UF 50V Z Y5V(F) 1508 R/TP
C376 , C378	0CH1104K942	CAPACITOR , CHIP	[CERAM 0.1UF 50V Z Y5V(F) 1508 R/TP
C301 , C302	0CH1225F944	CAPACITOR , FIXED	CERA 2UF 16V 80%,-20% Y5V(F) 3216 R
C325 , C327	0CH1225F944	CAPACITOR , FIXED	CERA 2UF 16V 80%,-20% Y5V(F) 3216 R
C328 , C346	0CH1225F944	CAPACITOR , FIXED	CERA 2UF 16V 80%,-20% Y5V(F) 3216 R
C340	0CH7106C611	CAPA , CHIP	TANRALUM 10UF 6.3V M 3216 TP(-)
R374 ~ R376	0RJ0622C677	RESISTOR , METAL	620HM 1/16 W 5% 1608 R/TP
IC401	0IBB171600A	IC , BURR BROWN	PCM1716E 28P SSOP TP DAC 2K/R
L401 , L402	6200HJC102A	FILTER(CIRC) , EMI	HB-1M2012-102JT CERATECH TP 3K
R420	0RH1000C622	RESISTOR , CHIP	100 1/16W 5 D.R/TP
R402	0RH4701C622	RESISTOR , CHIP	4.7K 1/16W 5 D.R/TP
R407	0RH6801C622	RESISTOR , CHIP	6.8K 1/16W 5 D.R/TP
C401 , C408	0CH1104K942	CAPACITOR , CHIP	[CERAM 0.1UF 50V Z Y5V(F) 1508 R/TP
C428	0CH1104K942	CAPACITOR , CHIP	[CERAM 0.1UF 50V Z Y5V(F) 1508 R/TP
C402 , C413	0CH1225F944	CAPACITOR , FIXED	CERA 2UF 16V 80%,-20% Y5V(F) 3216 R
C415	0CH1225F944	CAPACITOR , FIXED	CERA 2UF 16V 80%,-20% Y5V(F) 3216 R
C420	0CH1392K562	CAPACITOR , CHIP	[CERAM 3900PF 50V K Z5U(E) 1608 R/TP
R401	0RH0331C622	RESISTOR , CHIP	3.3 1/16W 5 D.R/TP
C403 , C404	0CH7106C611	CAPA , CHIP	TANTALUM 10UF 6.3V M 3216 TP(-)
R409 , R411	0RH8201C622	RESISTOR , CHIP	8.2K 1/16W 5 D.R/TP
	KOP11401CSMPS	POWER PCB SMPS ASS'Y	DVD-L55 ETC
		KWC1B2A08A170A	CARD CABLE
		KWC1B2A21A120B	CARD CABLE
JW61	KWEH202120PR	WIRE ASS'Y	120MM
	KQXDVDL55C	INSTRUCTION MANUAL ASS'Y	
	KJS4M011Y	CORD , PHONE	KJS4M011Z
	KJS4N001Y	CORD , PIN	
	KQX1A646Z	MANUAL , INSTRUCTION	DVD-L55C

SECTION 4 MECHANISM

CONTENTS

DECK MECHANISM PARTS LOCATIONS

- Top View.....4-2
- Top View(without Tray Disc)4-2
- Bottom View4-2

DECK MECHANISM DISASSEMBLY

- 1. Holder Clamp.....4-2
 - 1-1. Clamp Assembly Disc.....4-2
 - 1-1-1. Plate Clamp4-2
 - 1-1-2. Magnet Clamp4-2
 - 1-1-3. Clamp Upper.....4-2
- 2. Tray Disc4-2
- 3. Base Assembly Sled4-3
 - 3-1. Gear Assembly Feed4-3
 - 3-2. Gear Assembly Middle.....4-3
 - 3-3. Gear Assembly Rack4-3
- 4. Rubber Rear.....4-3

- 5. Frame Assembly Up/Down4-4
- 6. Belt Loading.....4-4
- 7. Gear Pulley4-4
- 8. Gear Loading4-4
- 9. Guide Up/Down.....4-4
- 10. PWB Assembly Loading4-4
- 11. Base Main.....4-4

EXPLODED VIEW

- 1. Deck Mechanism Exploded View....4-6

DECK MECHANISM PARTS LOCATION

• Top View (With Tray)

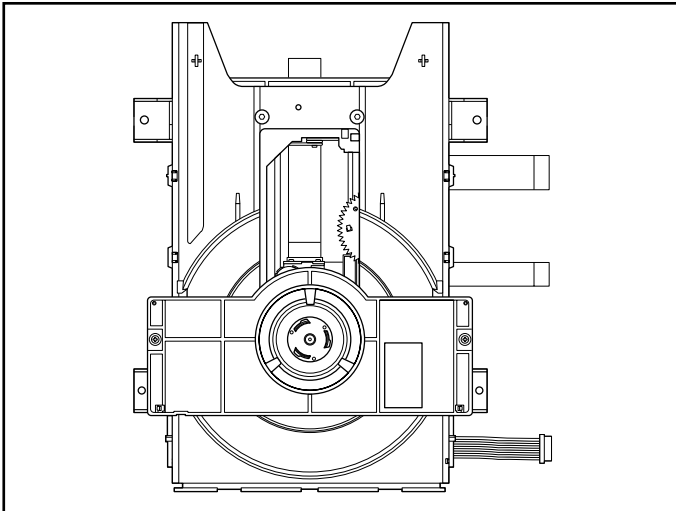

• Top View (Without Tray)

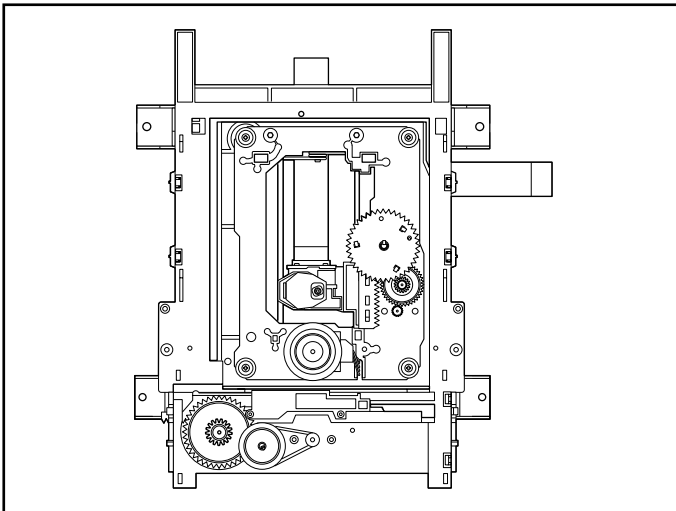

• Bottom View

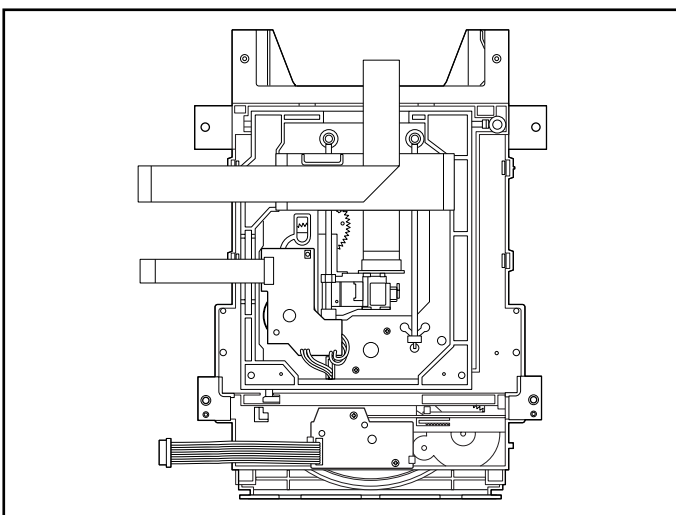

Procedure		Parts	Fixing Type	Disassembly	Figure
Starting No.					
	1	Holder Clamp	2 Screws, 2 Locking Tabs		4-1
1	2	Clamp Assembly Disc			4-1
1, 2	3	Plate Clamp			4-1
1, 2, 3	4	Magnet Clamp			4-1
1, 2, 3, 4	5	Clamp Upper			4-1
1	6	Tray Disc			4-2
1, 6	7	Base Assembly Sled			4-3
1, 2, 6	8	Gear Assembly Feed	4 Screws, 1 Connector 1 Locking Tabs		4-3
1, 2, 6, 8	9	Gear Middle			4-3
1, 2, 6, 8, 9	10	Gear Assembly Rack	1 Screw		4-3
1, 2, 7	11	Rubber Rear			4-3
1, 2, 7	12	Frame Assembly Up/Down	1 Screw	Bottom	4-4
1, 2	13	Belt Loading	1 Locking Tab		4-4
1, 2, 13	14	Gear Pulley			4-4
1, 2, 13, 14	15	Gear Loading	1 Locking Tab		4-4
1, 2, 7, 12, 13, 14	16	Guide Up/Down			4-4
1, 2, 13	17	PWB Assembly Loading	1 Locking Tab 1 Hook 2Screw	Bottom	4-4
1, 2, 7, 12, 13, 14, 15, 16, 17	18	Base Main	2 Locking Tabs		4-4

Note

When reassembling, perform the procedure in reverse order.

The "Bottom" on Disassembly column of above Table indicates the part should be disassembled at the Bottom side.

DECK MECHANISM DISASSEMBLY

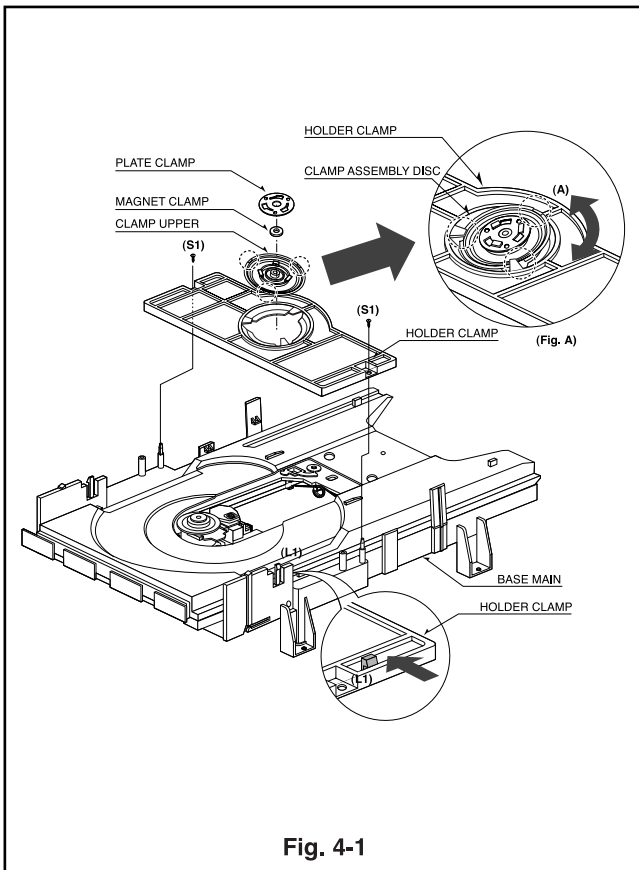

Fig. 4-1

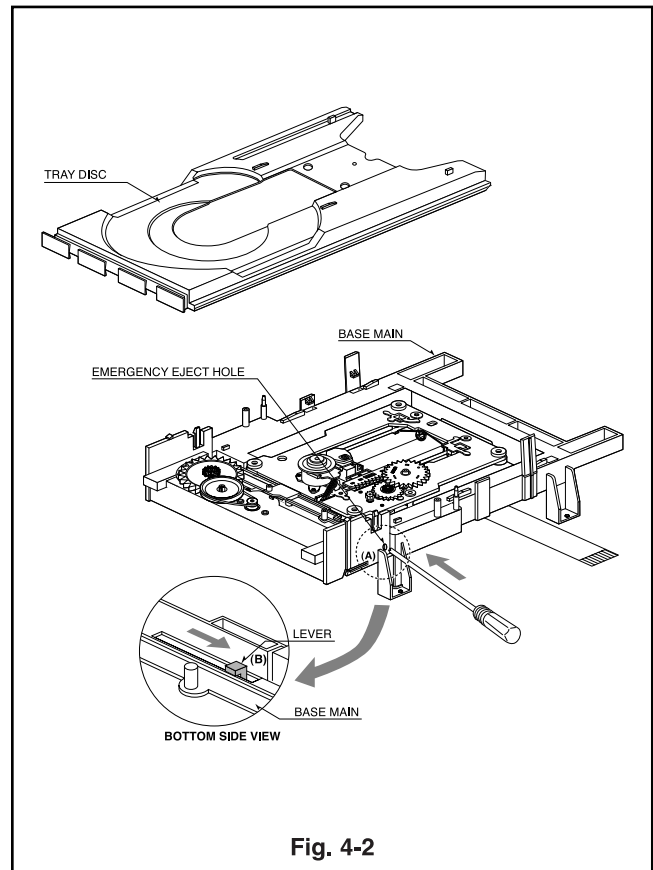

Fig. 4-2

1. Holder Clamp (Fig. 4-1)

- 1) Release 2 Screws(S1).
- 2) Unhook 2 Locking Tabs(L1).
- 3) Lift up the Holder Clamp and then separate it from the Base Main.

1-1. Clamp Assembly Disc

- 1) Place the Clamp Assembly Disc as Fig. (A)
- 2) Lift up the Clamp Assembly Disc in direction of arrow(A).
- 3) Separate the Clamp Assembly Disc from the Holder Clamp.

1-1-1. Plate Clamp

- 1) Turn the Plate Clamp to counterclockwise direction and then lift up the Plate Clamp.

1-1-2. Magnet Clamp

1-1-3. Clamp Upper

2. Tray Disc (Fig. 4-2)

- 1) Insert and push a Driver in the emergency eject hole(A) at the right side, or put the Driver on the Lever(B) of the Gear Emergency and pull the Lever(B) in direction of arrow so that the Tray Disc is ejected about 15~20mm.
- 2) Pull the Tray Disc until it is separated from the Base Main completely.

DECK MECHANISM DISASSEMBLY

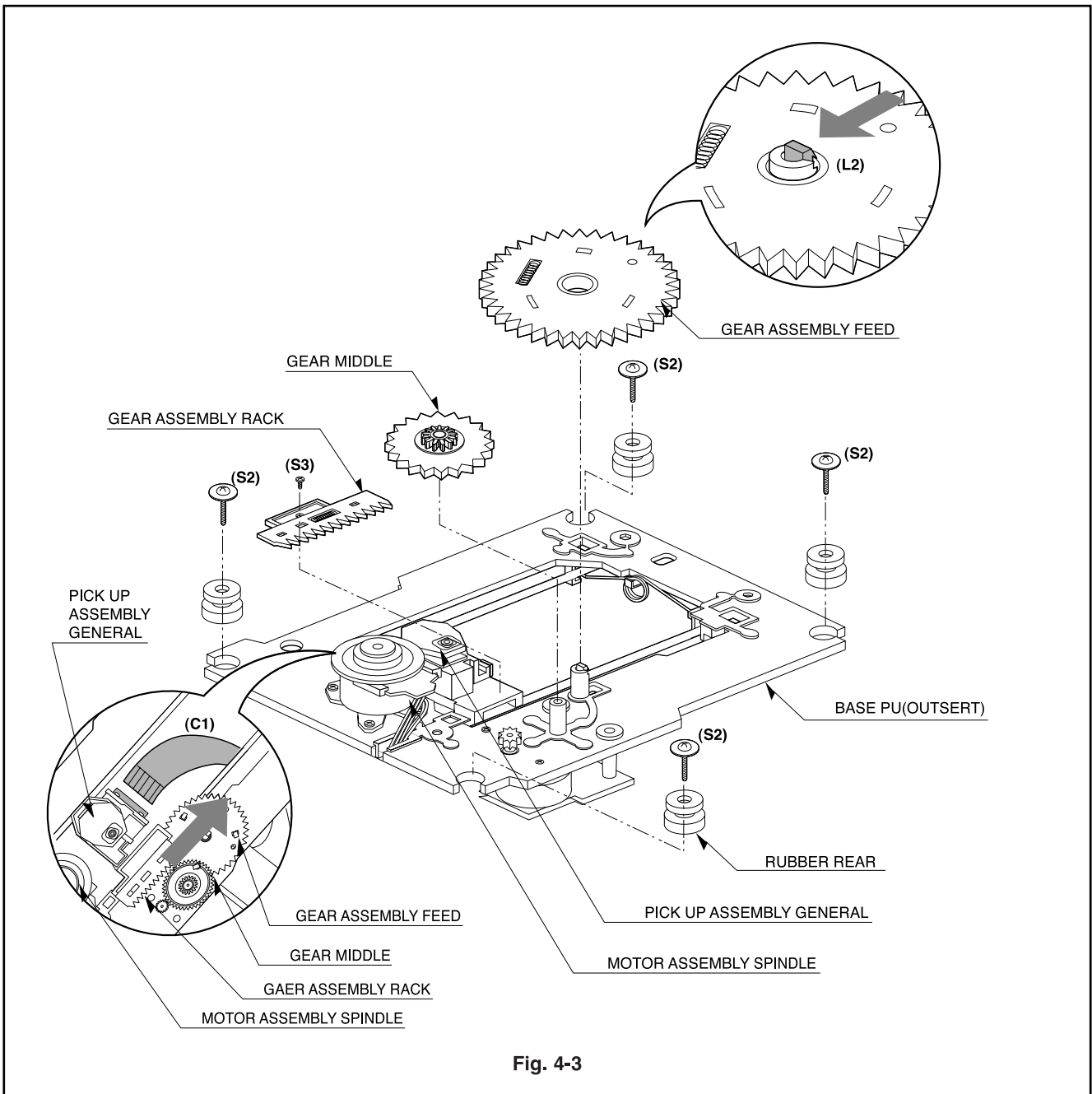

Fig. 4-3

3. Base Assembly Sled (Fig. 4-3)

- 1) Release 4 Screw(S2).
- 2) Disconnect the FFC Connector(C1)

3-1. Gear Assembly Feed

- 1) Unhook the Locking Tab(L2) in direction of arrow.

3-2. Gear Middle

3-3. Gear Assembly Rack

- 1) Release the Scerw(S3)

4. Rubber Rear (Fig. 4-3)

DECK MECHANISM DISASSEMBLY

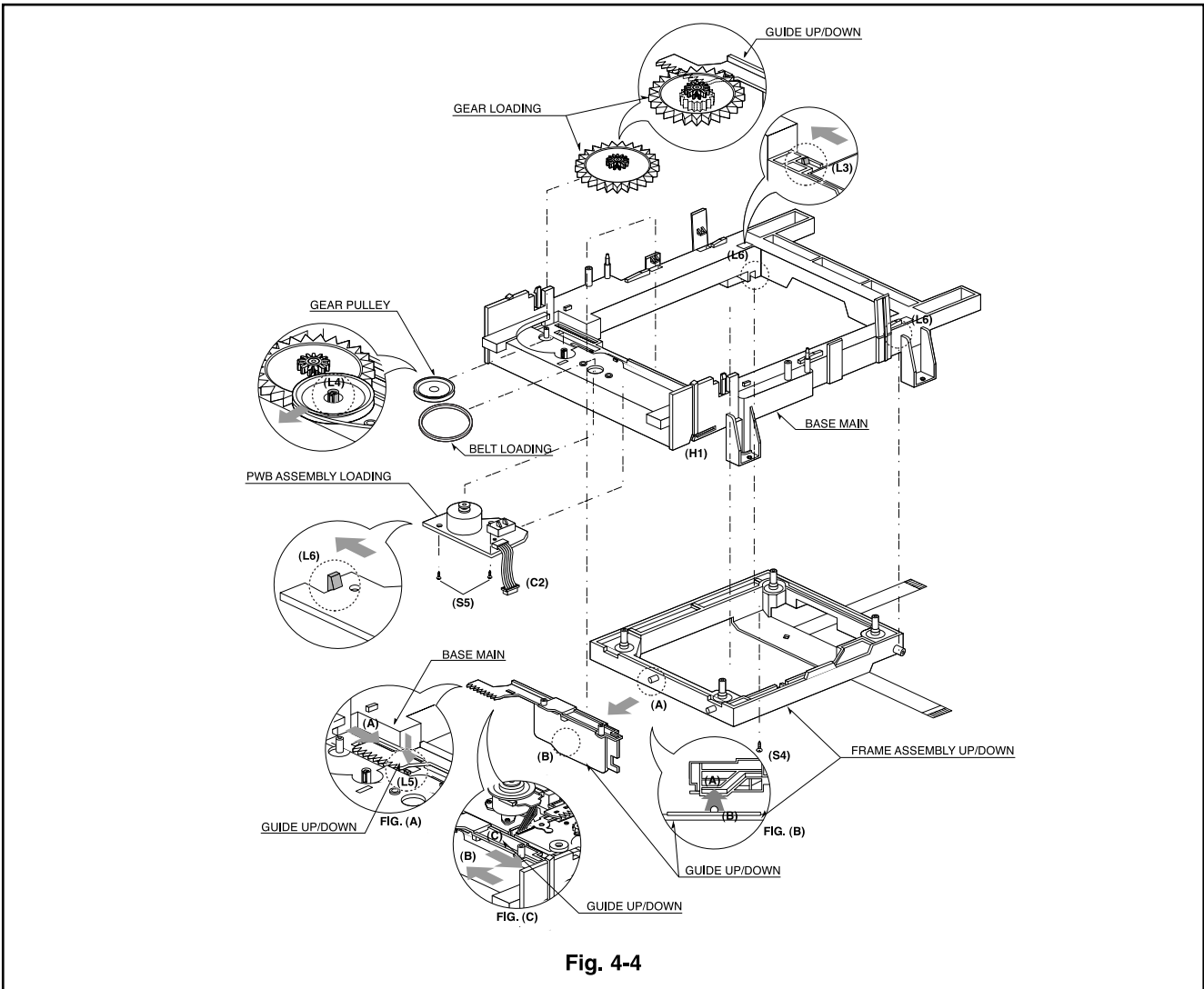

Fig. 4-4

5. Frame Assembly Up/Down

Note

Put the Base Main face down(Bottom Side)

- 1) Release the Screw(S4)
- 2) Unlock the Locking Tab(L3) in direction of arrow and then lift up the Frame Assembly Up/Down to separate it from the Base Main.

Note

- When reassembling move the Guide Up/Down in direction of arrow(C) until it is positioned as Fig.(C).
- When reassembling insert (A) portion of the Frame Assembly Up/Down in the (B) portion of the Guide Up/Down as Fig.(B)

6. Belt Loading(Fig. 4-4)

Note

Put the Base Assembly Main on original position(Top Side)

7. Gear pulley (Fig. 4-4)

- 1) Unlock the Locking Tab(L4) in direction of arrow(B) and then separate the Gear Pulley from the Base Main.

8. Gear Loading (Fig. 4-4)

9. Guide Up/Down (Fig. 4-4)

- 1) Move the Guide Up/Down in direction of arrow(A) as Fig.(A)
- 2) Push the Locking Tab(L5) down and then lift up the Guide Up/Down to separate it from the Base Main.

Note

When reassembling place the Guide Up/Down as Fig.(C) and move it in direction arrow(B) until it is locked by the Locking Tab(L5). And confirm the Guide Up/Down as Fig.(A)

10. PWB Assembly Loading

Note

Put the Base Main face down(Bottom Side)

- 1) Release 2 Screws(S5)
- 2) Unhook the Loading Motor Connector (C2) from the Hook (H1) on the Base Main.
- 3) Unlock 2 Locking Tabs(L6) and separate the PWB Assembly Loading from the Base Main.

11. Base Main(Fig. 4-4)

EXPLODED VIEWS

1. Deck Mechanism Exploded View

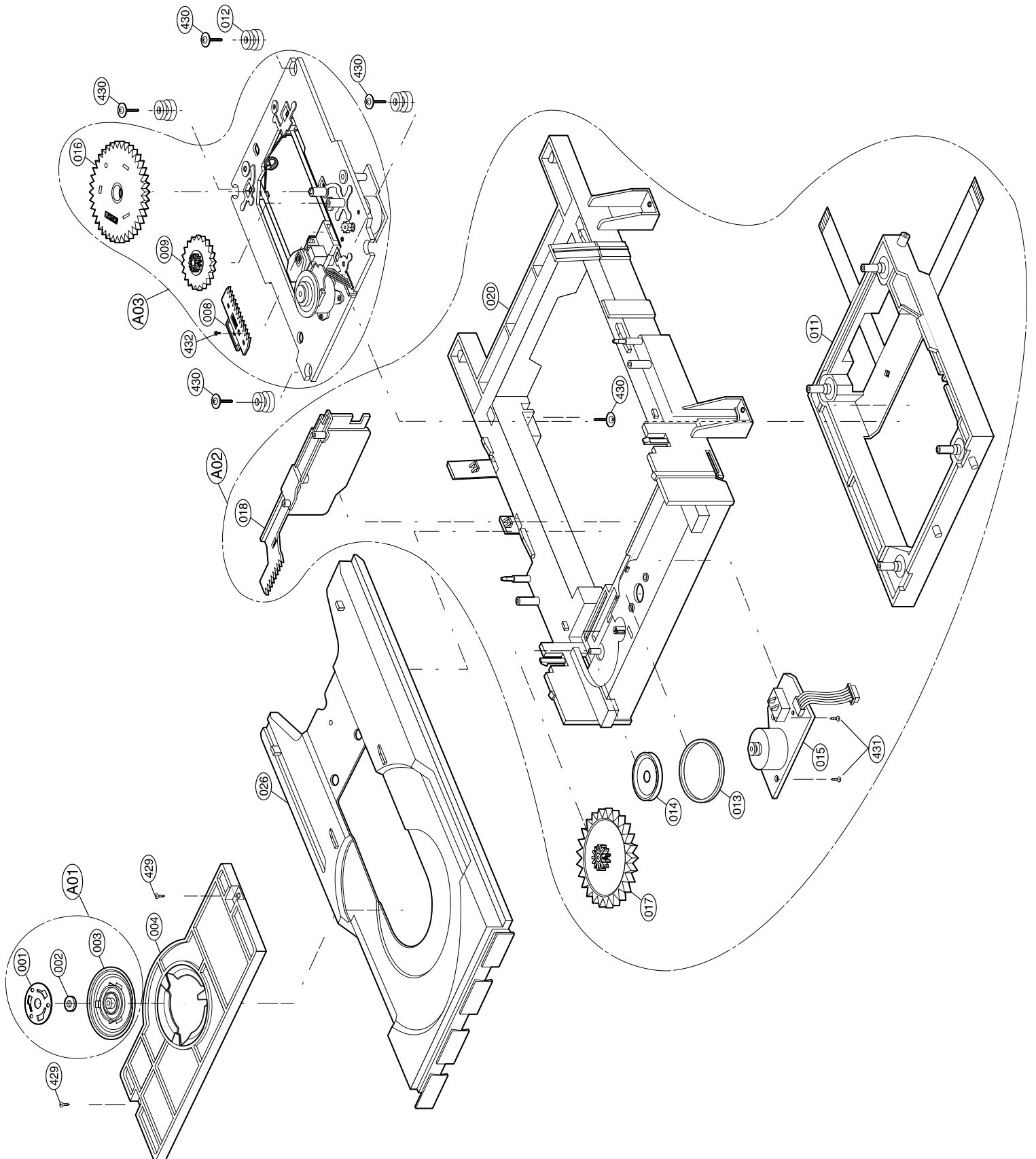

PARTS LIST

LOAD No.	PART No.	DESCRIPTION	REMARKS
A01	4931R-0037A	HOLDER ASSY	CLAMP
A02	3041R-0014A	BASE ASSY	TRAY (DPM1)
A03	3041R-0015A	BASE ASSY	SLED-DAMPER
A04	3041R-0016A	BASE ASSY	MAIN
001	3300R-0547A	PLATE	CLAMP
002	5016H-1016B	MAGNET	CLAMP(LDM-R608,10*5,1*1.5T)
003	4860R-0009A	CLAMP	UPPER
004	4930R-0197A	HOLDER	CLAMP
008	4470R-0047A	GEAR	ASSY RACK
009	4470R-0053A	GEAR	MIDDLE
011	3210R-0041A	FRAME	UP/DOWN
012	5040R-0047D	RUBBER	DAMPER(HARDNESS=30) , DARKGREEN
013	6871R-3029A	PWB(PCB) ASSY , TOTAL	DPM1 JUNCTION
014	5040R-0047A	RUBBER	REAR(E2,5040H-1054A) , YAMAUCHI
016	4470R-0050A	GEAR	ASSY FEED
020	4470R-0073A	GEAR	WHEEL TRAY
021	4470R-0074A	GEAR	TRAY
022	6871R-3024A	PWB(PCB) ASSY , TOTAL	DPM1 TRAY
023	4580R-0006A	ROLLER	BASE TRAY
024	4681R-0010A	MOTOR ASSY	TRAY
025	3040R-0032A	BASE	TRAY (DPM1)
026	3390R-0008A	TRAY	DISC (DPM1)
030	3040R-0031A	BASE	MAIN (DPM1)
031	4470R-0069A	GEAR	SLIDER
032	4470R-0067A	GEAR	MAIN
033	4470R-0070A	GEAR	EXCHANGE
034	4470R-0068A	GEAR	UP/DOWN
035	4470R-0071A	GEAR	LOADING
036	4681R-0012A	MOTOR ASSY	MAIN
037	4470R-0072A	GEAR	WHEEL MAIN
038	6871R-3026A	PWB(PCB) ASSY , TOTAL	DPM1 MAIN-MODE
413	4000R-0006A	SCREW	TAPTITE 3*8 (353-025B)
414	4000R-0006B	SCREW	TAPTITE 3X10 FBK (353-025C)
416	4404R-0017A	MECHANISM	3*12*12 (88H-0004)
430	1SZZH-1003A	SCREW	+ D2.0 6MM SWRCH16A/NIY 4.5MM
432	1SZZR-0011A	SCREW	MACHINE