

# SERVICE MANUAL

**NAD**

**C 740**

**STEREO  
RECEIVER**

**C 740**

**STEREO  
RECEIVER**

## SERVICE SAFETY PRECAUTIONS

### 1. Replacing the fuses

CAUTION: FOR CONTINUED PROTECTION AGAINST THE RISK OF FIRE  
REPLACE ONLY WITH SAME TYPE OF FUSE.

Reference No.	Part No.	Description
F901*AH	252161	3A-125V UL/T-237 Time lag
F901*B1, B, C	252074	T2A L/250V SE-EAK Time lag

#### NOTE:

<\*AH> : U. S. A., CANADIAN MODEL ONLY. <\*B1> : AUSTRALIAN MODEL ONLY.  
<\*C> : EUROPEAN MODEL ONLY. <\*B> : U.K. MODEL ONLY.

### 2. SAFETY CHECK OUT

(Only U.S.A. model)

Before returning the product to the customer, make leakage current or resistance measurements to determine that exposed parts are acceptably insulated from the supply circuit.

Parts marked with the symbol  are critical with regard to the risk of fire and electric shock. Replace only with parts recommended by the manufacturer.

## CONTENTS

DESCRIPTION	PAGE
SERVICE SAFETY PRECAUTIONS .....	2
FRONT PANEL/REAR PANEL VIEW .....	3
CONNECTION OF INSTRUMENT .....	4
ALIGNMENT PROCEDURE .....	5
SPECIFICATIONS .....	6
PCB LAYOUT .....	7-8
SCHEMATIC DIAGRAM .....	9-11
MICROPROCESSOR CONNECTION DIAGRAM & TERMINAL DESCRIPTION .....	12
IC BLOCK DIAGRAM .....	13-15
RF SECTION BLOCK DIAGRAM .....	16
AF SECTION BLOCK DIAGRAM .....	17
EXPLODED VIEW .....	18
EXPLODED VIEW PARTS LIST .....	19-20
WIRING DIAGRAM .....	21
ELECTRICAL PARTS LIST .....	22-25
PACKING DIAGRAM/PARTS LIST .....	26
RUNNING CHANGE INFORMATION .....	27

**WARNING: TO PREVENT FIRE OR ELECTRIC SHOCK, DO NOT EXPOSE THIS APPLIANCE TO RAIN OR MOISTURE.**

## FRONT PANEL CONTROLS

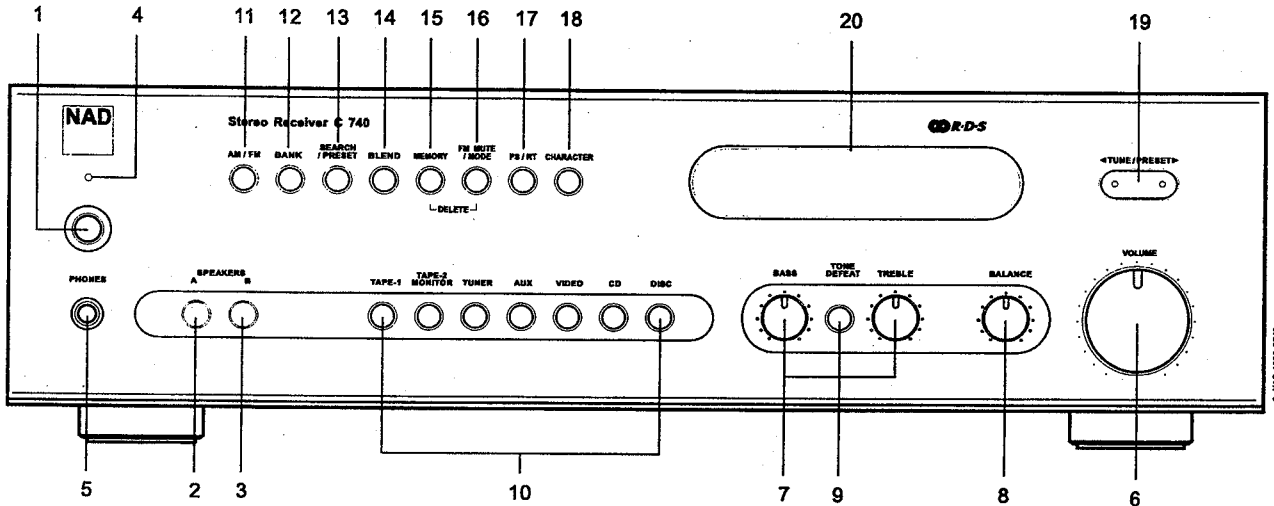

- |                      |                           |   |                   |
|----------------------|---------------------------|---|-------------------|
| 1. POWER ON/OFF      | 7. BASS & TREBLE CONTROLS | 13. SEARCH/PRESET                                       | 18. CHARACTER     |
| 2. SPEAKERS A        | 8. BALANCE                | 14. BLEND   | 19. TUNE/PRESET   |
| 3. SPEAKERS B        | 9. TONE DEFEAT            | 15. MEMORY  | 20. DISPLAY PANEL |
| 4. STANDBY INDICATOR | 10. INPUT SELECTORS       | 16. FM MUTE/MODE  |                   |
| 5. HEADPHONE SOCKET  | 11. AM/FM                 | 17. PS/RT (RDS Version) or<br>DISPLAY (non-RDS version) |                   |
| 6. VOLUME            | 12. BANK                  |   |                   |



The lightning flash with arrowhead, within an equilateral triangle is intended to alert the user of the presence of un-insulated "dangerous voltage" within the product's enclosure; that may be of sufficient magnitude to constitute a risk of electric shock to persons.



The exclamation point within an equilateral triangle is intended to alert the user of the presence of important operating and maintenance (servicing) instructions in the literature accompanying the appliance.

## REAR PANEL CONNECTIONS

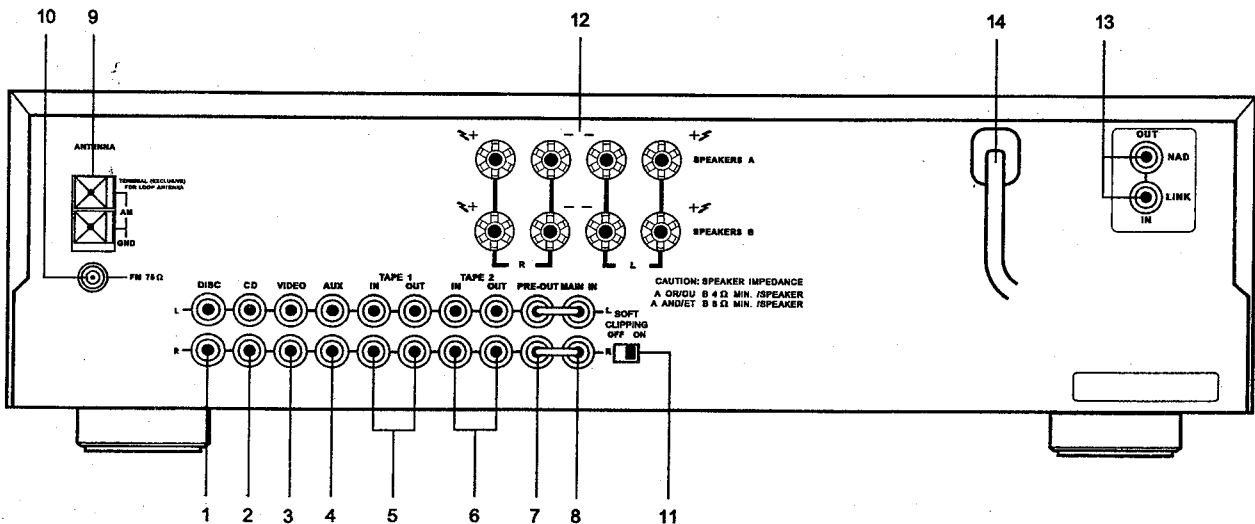

- |                |                  |               |   |
|----------------|------------------|---------------|---|
| 1. DISC INPUT  | 4. AUX INPUT     | 7. PRE OUT    | 10. FM ANTENNA (F-type terminal for AH, DIN for B, B1, C) |
| 2. CD INPUT    | 5. TAPE 1 IN/OUT | 8. MAIN IN    | 11. SOFT CLIPPING   |
| 3. VIDEO INPUT | 6. TAPE 2 IN/OUT | 9. AM ANTENNA | 12. SPEAKERS A + B  |
|                |                  |               | 13. NAD LINK IN, OUT                                      |
|                |                  |               | 14. AC LINE CORD  |

# CONNECTION OF INSTRUMENT

## FM Adjustment

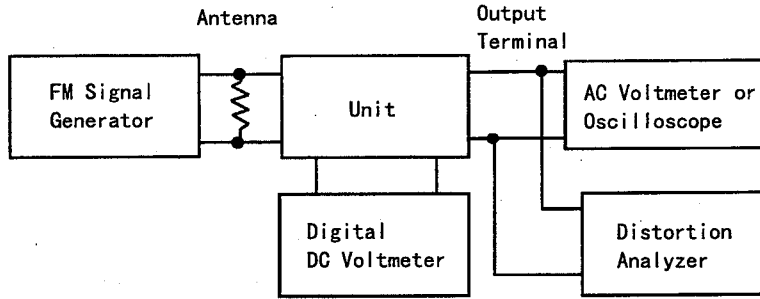

## FM Stereo Adjustment

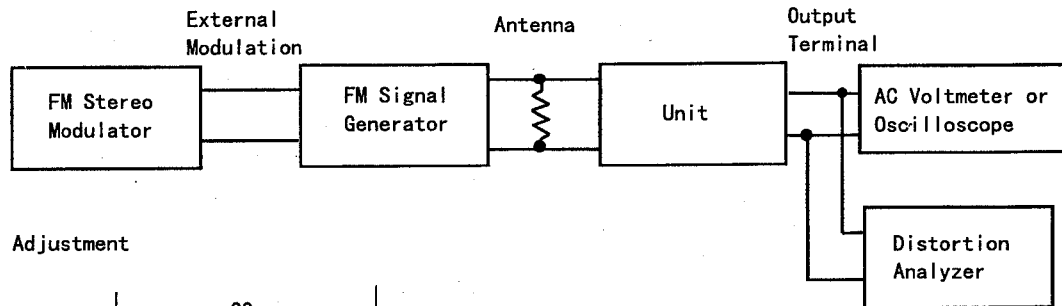

## AM Adjustment

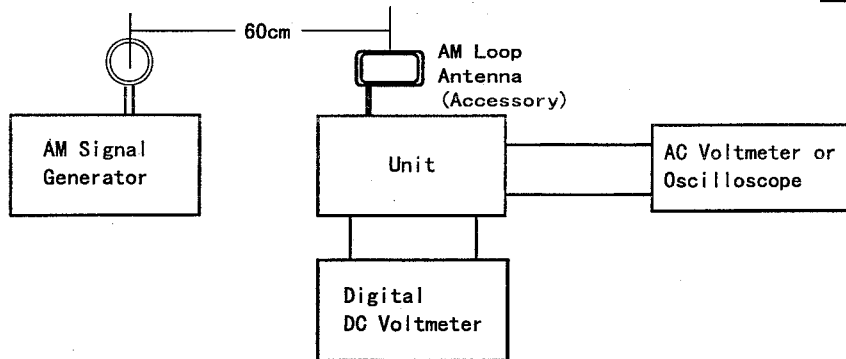

## Adjustment Point

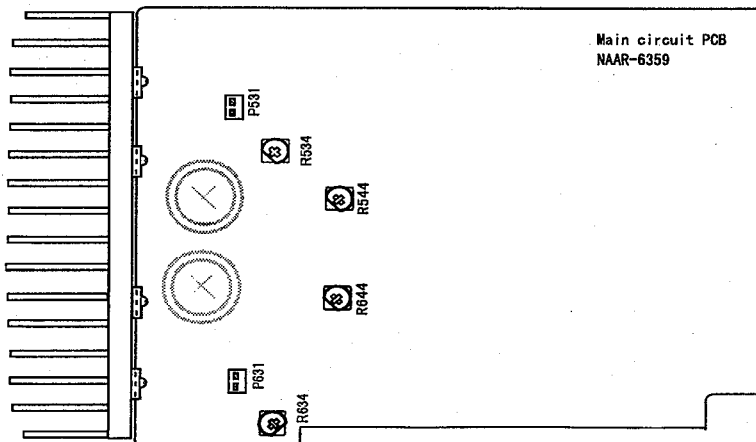
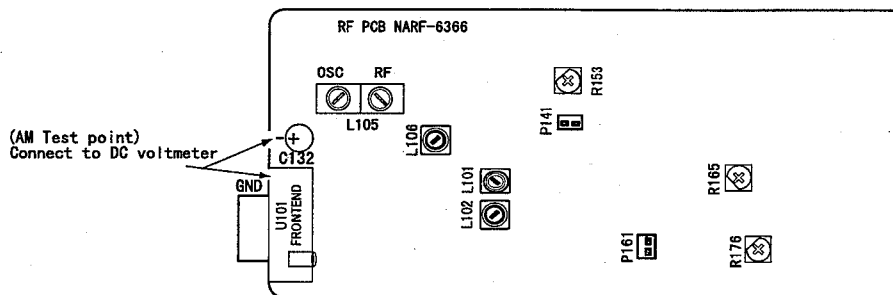

# ALIGNMENT PROCEDURE

## 1. FM Adjustment

- a. Set the unit's frequency to 99.0MHz.
- b. Connect a dc volt meter with P141.
- c. Set FM MUTE/MODE SW (S717) to stereo.
- d. Set SSG(Standard Signal Generator) frequency to 99.0MHz, output to 60dB  $\mu$  V and connect to 75 ohm antenna terminal.
- e. Turn the core of L101(NFIF-4087) so that the voltage can be within  $\pm 20$ mV.
- f. Turn the core of L102(NFIF-4088) so that mono distortion goes minimum.
- g. Repeat above items(e & f) a few times.
- h. Connect a Frequency counter with P161.
- i. Turn R176 so that the frequency can be within 19kHz  $\pm$  10Hz.
- j. Set the output of SSG to stereo.
- k. Turn IFT in the frontend(U101) within  $\pm 180$  degrees so that stereo distortion can be minimum.
- l. Adjust R165 and get maximum stereo separation.
- m. Set SSG output to 17dBuV.
- n. Adjust R153 so that STEREO indicator turns ON. As a optional method, judging by wave form is admitted.
- o. Repeat above items(m and n) a few times.

## 2. AM Adjustment

<AH> model

Step	AM SG output	Tuning Frequency	Output Indicator	Adjustment Point	Adjust for
1		530kHz	Digital DC voltmeter	OSC coil on RF Block L105	1.3V $\pm$ 0.2V
2	600kHz 400Hz 30% mod. 60dB/ m	600kHz	AC voltmeter	RF coil on RF Block L105	Maximum
3	990kHz 400Hz 30% mod. 60dB/ m	990kHz	AC voltmeter	L106	Maximum

Reference Specification

FM tuned voltage 87.50MHz ~ 108.00MHz

More than 1.2V ~ Less than 10V

AM tuned voltage 530kHz ~ 1710kHz

1.3V ~ Less than 9.0V

<C, B, B1> models

Step	AM SG output	Tuning Frequency	Output Indicator	Adjustment Point	Adjust for
1		522kHz or 531kHz	Digital DC voltmeter	OSC coil on RF Block L105	1.3V $\pm$ 0.2V
2	603kHz 400Hz 30% mod. 60dB/ m	603kHz	AC voltmeter	RF coil on RF Block L105	Maximum
3	999kHz 400Hz 30% mod. 60dB/ m	999kHz	AC voltmeter	L106	Maximum

Reference Specification

FM tuned voltage 87.50MHz ~ 108.00MHz

More than 1.2V ~ Less than 10V

AM tuned voltage 522kHz ~ 1611kHz

1.3V ~ Less than 9.0V

## 3. POWER AMP ADJUSTMENT

Idle Current

- a. By adjusting R534 and R634, set the voltage between test points P531 and P631 to 6.0mV  $\pm$  1.0mV immediately after the power is switched on.
- b. After 4 ~ 6 minutes with the power on, readjust R534 and R634 to 5.0mV  $\pm$  1.0mV.

Offset Voltage

- a. After 4 ~ 6 minutes with the power on, adjust R544 and R644 to 0mV  $\pm$  20mV.

# SPECIFICATIONS

## Test conditions

- ① Power Supply Voltage & Frequency  
 AH Type 120V / 60Hz  
 C,B,B1 Type 230V / 50Hz

- ② Load Resistance  
 Speaker Terminal 8 ohms / 4 ohms  
 Other Terminal 47kohms

- ③ Temperature & Humidity  
 Temperature 5 ~ 35 °C  
 Humidity 45 ~ 85 % RH

- ④ Standard Knob and Switch Position (S.K.P.)
- |                          |         |                  |             |
|--------------------------|---------|------------------|-------------|
| a. Master Volume Control | Maximum | f. Tape Monitor  | OFF         |
| b. Bass Control          | Center  | g. Muting        | OFF         |
| c. Treble Control        | Center  | h. Speaker       | A ON ,B OFF |
| d. Balance Control       | Center  | i. Soft Clipping | OFF         |
| e. Input Selector        | CD      | j. Tone Defeat   | OFF         |

- ⑤ Modulation  
 FM Mono 75.0kHz Deviation (Mod.=1kHz)  
 Stereo L + R = 67.5kHz Deviation (Mod.=1kHz)  
 Pilot = 7.5kHz Deviation (19kHz)  
 RDS = 1.0kHz Deviation (57kHz)  
 AM 400Hz, 30%
- ⑥ Reduce the following value from signal generator  
 FM 75 ohms 0dB  
 300 ohms -12dB  
 AM Loop Antenna -26dB

Available Remote Control Unit : RC-450S

## [AUDIO SECTION]

Max. Power 1kHz/20kHz/20Hz L,R-ch (Sel.:CD) 35 W min. L/R  
 Both Channel Driven Only Variable  
 8 Ω Load

Both Channel Driver 1kHz/20kHz/20Hz L,R-ch (Sel.:CD) 35 W min. L/R  
 4 Ω Load Only Variable

Line Separation	100Hz	- 17dBV	55.0 dB min.	L/R The Reverse Channel
	10kHz	- 17dBV	35.0 dB min.	L/R Terminated with 5.1kohm
Hum & Noise	CD	No Signal S.K.P.	-55.0 dBV	L/R Terminated With 5.1kohm
		Volume:Min.	-60.0 dBV	L/R Terminated With 5.1kohm
Bass Min.	100Hz	-10dBV' Vol:Mech.Center	- 6.0 ± 1.5 dB	
		Bass / Min.		
Bass Max.	100Hz	-10dBV' Vol:Mech.Center	+ 6.0 ± 1.5 dB	
		Bass/Max		
Treble Min	10kHz	-10dBV	- 7.5 ± 1.5 dB	
		Treble/Min.		
Treble Max.	10kHz	-10dBV' Vol:Mech.Center	+ 7.5 ± 1.5 dB	
		Treble/Max.		

## [AM SECTION]

Tuning Range Fmin. AH / C, B, B1 530 / 522 kHz Freq. Step: AH/C, B, B1 = 10/9 kHz  
 Fmax. AH / C, B, B1 1710 / 1611 kHz Changing the AM band step

	to 10kHz step	to 9kHz step
R737	10k ohm	5.6k ohm

Input=60dB/m

Maximum Sensitivity	603, 990, 1404 kHz	60dB/m max.
	(600, 990, 1400)	
Usable Sensitivity	603, 990, 1404 kHz	15dB min.
	(600, 990, 1400)	40dB min.
Image Rejection Ratio	1404/1400kHz	28dB min.
IF Rejection Ratio	600/603kHz	24dB min.
Selectivity	990±9kHz	24dB min.
Fixed Output Level	990kHz	100mV min.

Input=100dB/m

## [FM SECTION]

Tuning Range	Fmin.	87.5 MHz	Freq. Step(Manual:25KHz)
	Fmax.	108.0 MHz	Auto:AH/C, B, B1=100/50KHz
Usable Sensitivity	87.5,98,108 MHz	30dB min.	Input=12dB μ
3dB Limited Sensitivity	98MHz	6dB μ max.	
Image Rejection Ratio	108MHz	35/75dB min.	(AH/ C, B, B1)
IF Rejection Ratio	90MHz	70dB min.	
Selectivity	98MHz	40/65dB min.	(AH/ C,B,B1)
Signal to Noise Ratio	98MHz	64dB min.	Input=60dB μ V
Fixed Output Level	98MHz	550±200mV	Input=60dB μ
	AH	750±250mV	
	C,B		

## [FM STEREO]

Blend	98MHz	(L/R Separation at Blend ON)	13±3dB	Input=60dB μ mod=1kHz
Muting	98MHz	Width	35±10kHz	Adjust L102
		Depth	35 dBu max.	Audition Input=60dB μ
				1KHz deviation

**PCB LAYOUT**

**U09 : NAPS-6367 Power supply PC board**

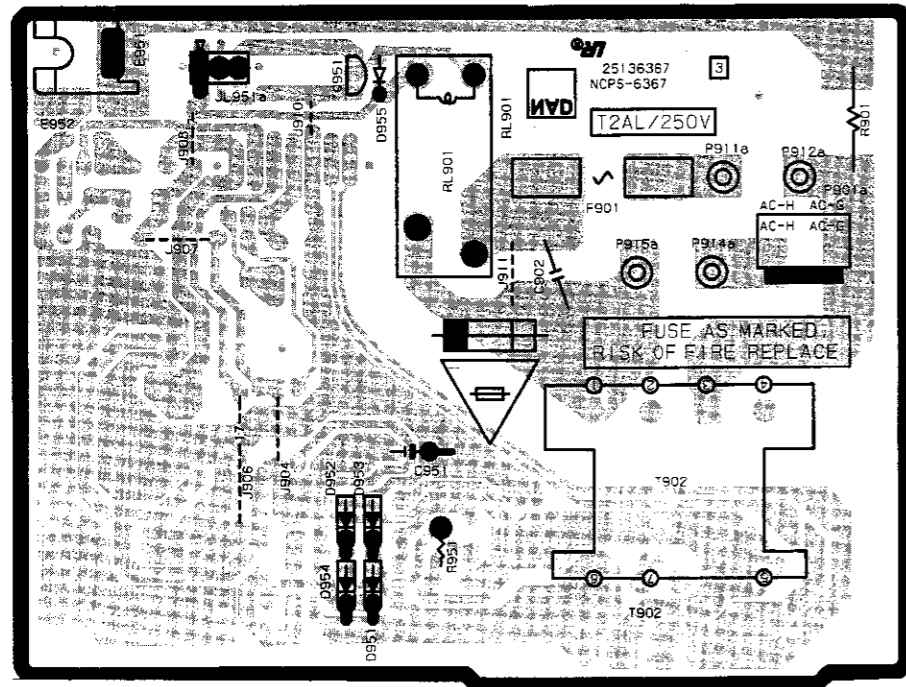

**U11 : NASW-6369 Power switch PC board**

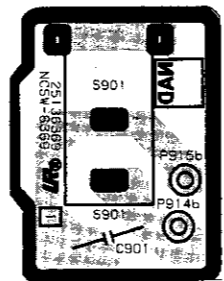

**U10 : NADG-6368 NAD link PC board**

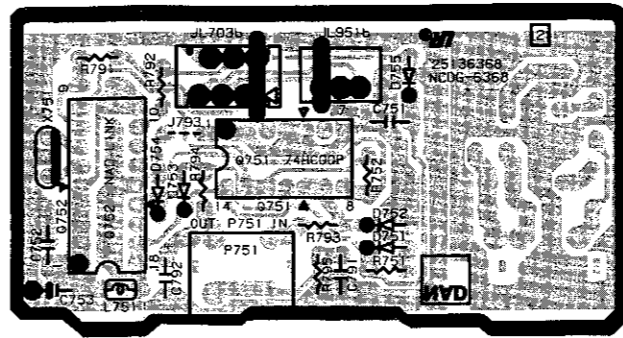

**U08 : NARF-6366 RF circuit PC board**

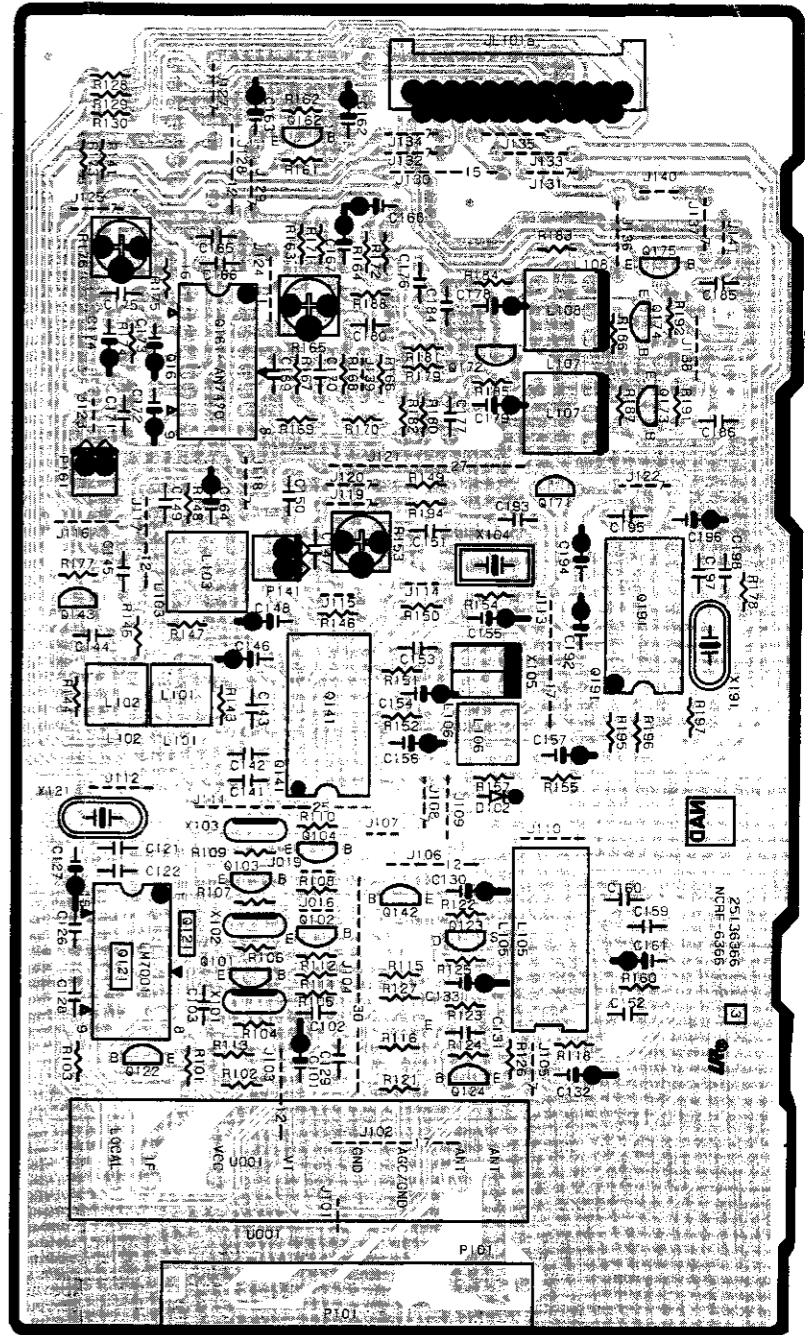

**U12 : NAETC-6370 Other PC board**

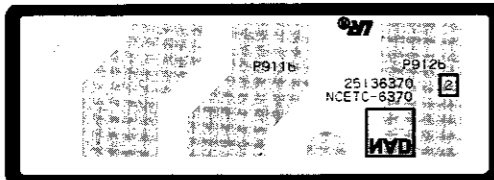

**U13 : NAETC-6373 LED PC board**

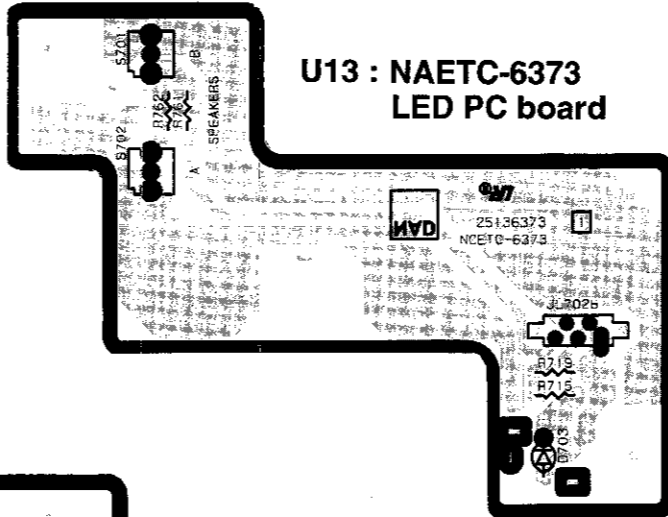

**U07 : NADIS-6365 Display circuit PC board**

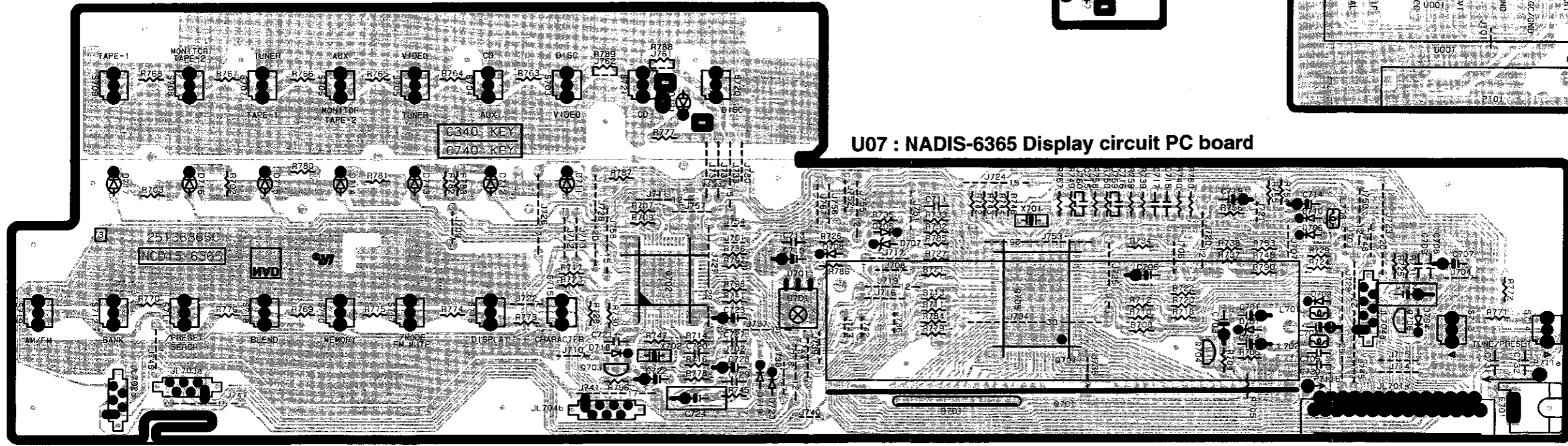



U01 : NAAR-6539 Main circuit PC board

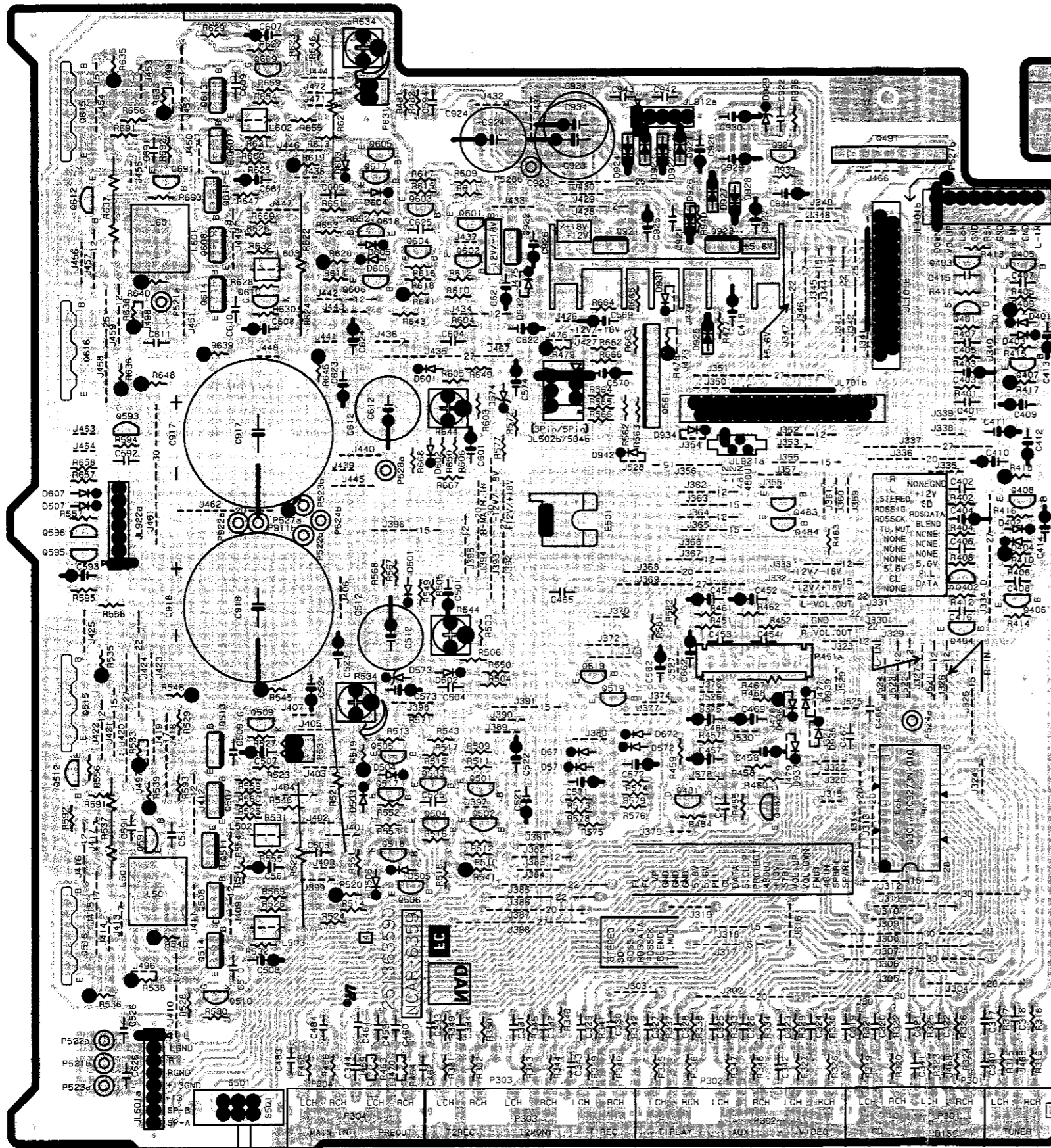

U04 : NAETC-6362 Speaker terminal PC board

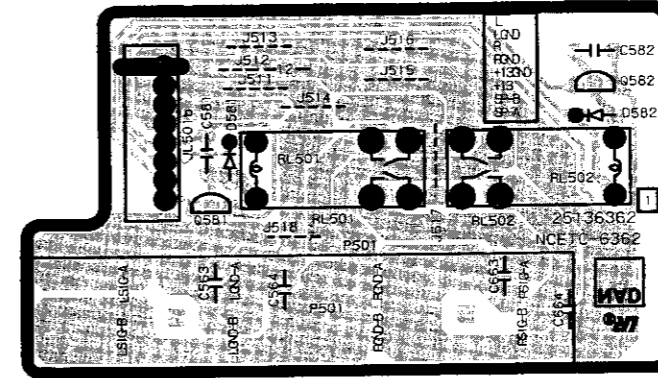

U06 : NAETC-6364 Transformer PC board

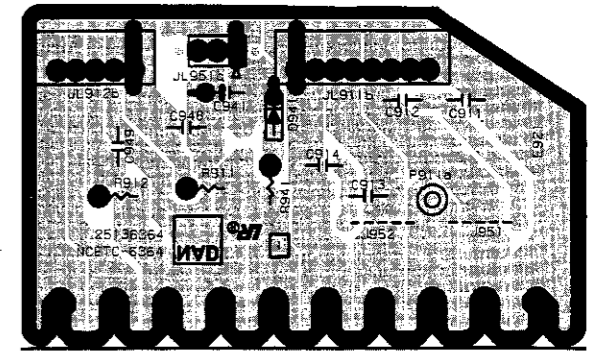

U14 : NAETC-6513 Sub PC board

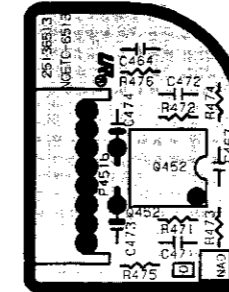

U03 : NAFF-6361 Control circuit PC board

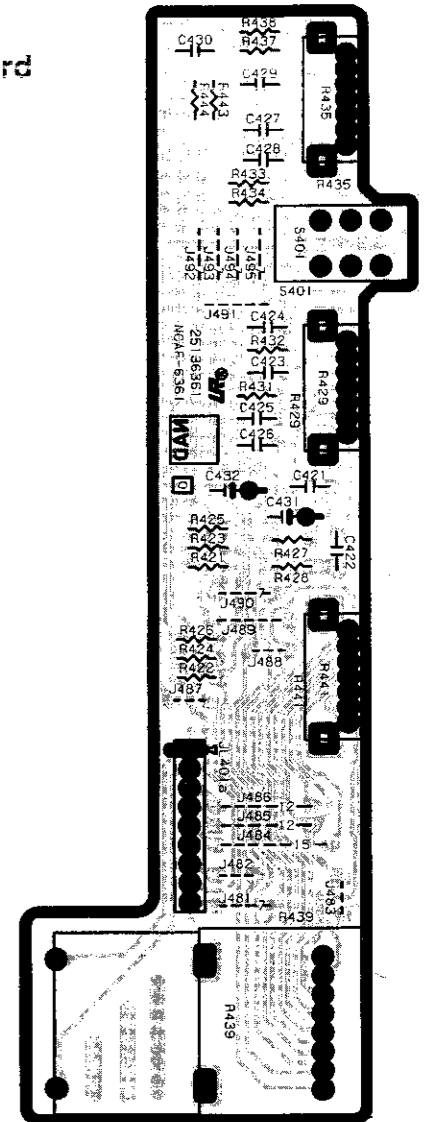

U05 : NAETC-6363 Head phone PC board

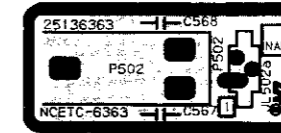

U02 : NAPS-6360 Sub power supply PC board

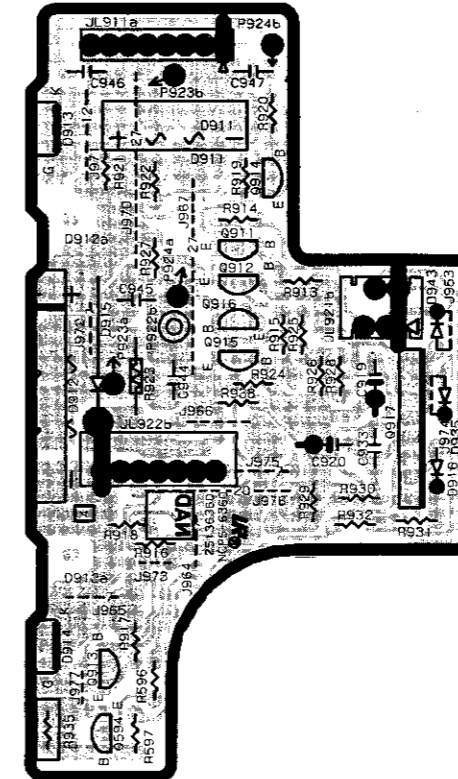



# SCHEMATIC DIAGRAM

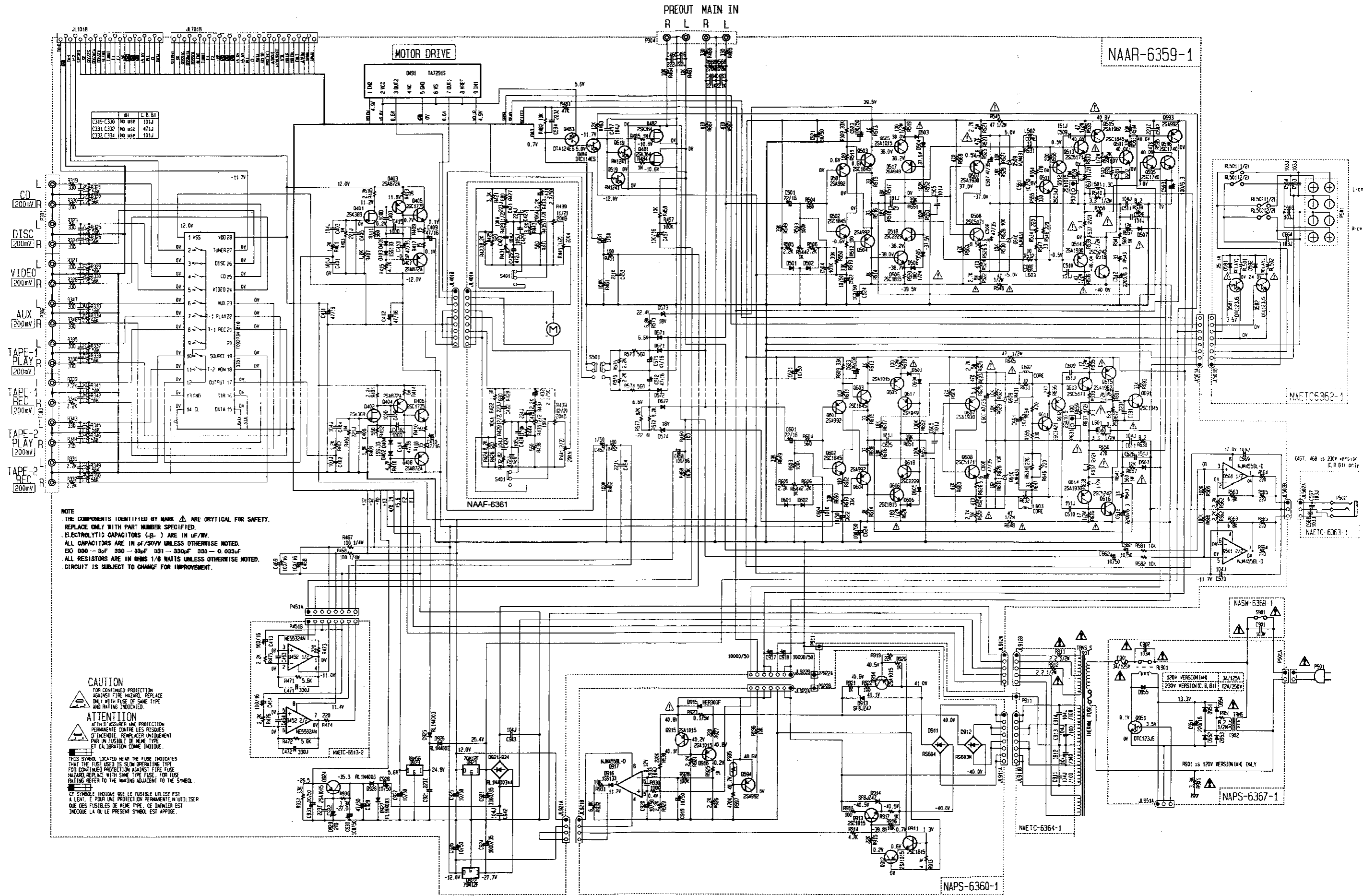

NOTE  
 THE COMPONENTS IDENTIFIED BY MARK  $\Delta$  ARE CRITICAL FOR SAFETY. REPLACE ONLY WITH PART NUMBER SPECIFIED.  
 ELECTROLYTIC CAPACITORS (-E-) ARE IN  $\mu$ F/50V.  
 ALL CAPACITORS ARE IN pF/50V UNLESS OTHERWISE NOTED.  
 EX 030 - 3pF 330 - 33pF 331 - 330pF 333 - 0.033 $\mu$ F  
 ALL RESISTORS ARE IN OHMS 1/8 WATTS UNLESS OTHERWISE NOTED.  
 CIRCUIT IS SUBJECT TO CHANGE FOR IMPROVEMENT.

**CAUTION**  
 FOR CONTINUED PROTECTION AGAINST FIRE HAZARD, REPLACE ONLY WITH FUSE OF SAME TYPE AND RATING INDICATED.

**ATTENTION**  
 POUR D'ASSURER UNE PROTECTION PERMANENTE CONTRE LES RISQUES D'INCENDIE, REMPLACER UNIQUEMENT PAR UN FUSIBLE DE MÊME TYPE ET CALIBRAGE COMME INDICÉ.

THIS SYMBOL LOCATED NEAR THE FUSE INDICATES THAT THE FUSE USED IS SLOW OPERATING TYPE FOR CONTINUED PROTECTION AGAINST FIRE HAZARD. REPLACE WITH SAME TYPE FUSE. FOR FUSE RATINGS REFER TO THE MARKING ADJACENT TO THE SYMBOL.

CE SYMBOLE INDIQUE QUE LE FUSIBLE UTILISÉ EST À LÉVÉ. POUR UNE PROTECTION PERMANENTE, UTILISER QUE DES FUSIBLES DE MÊME TYPE. CE D'AVERTISSEMENT INDIQUE LA OU LE PRÉSENT SYMBOLE EST ADJOSÉ.

# SCHEMATIC DIAGRAM

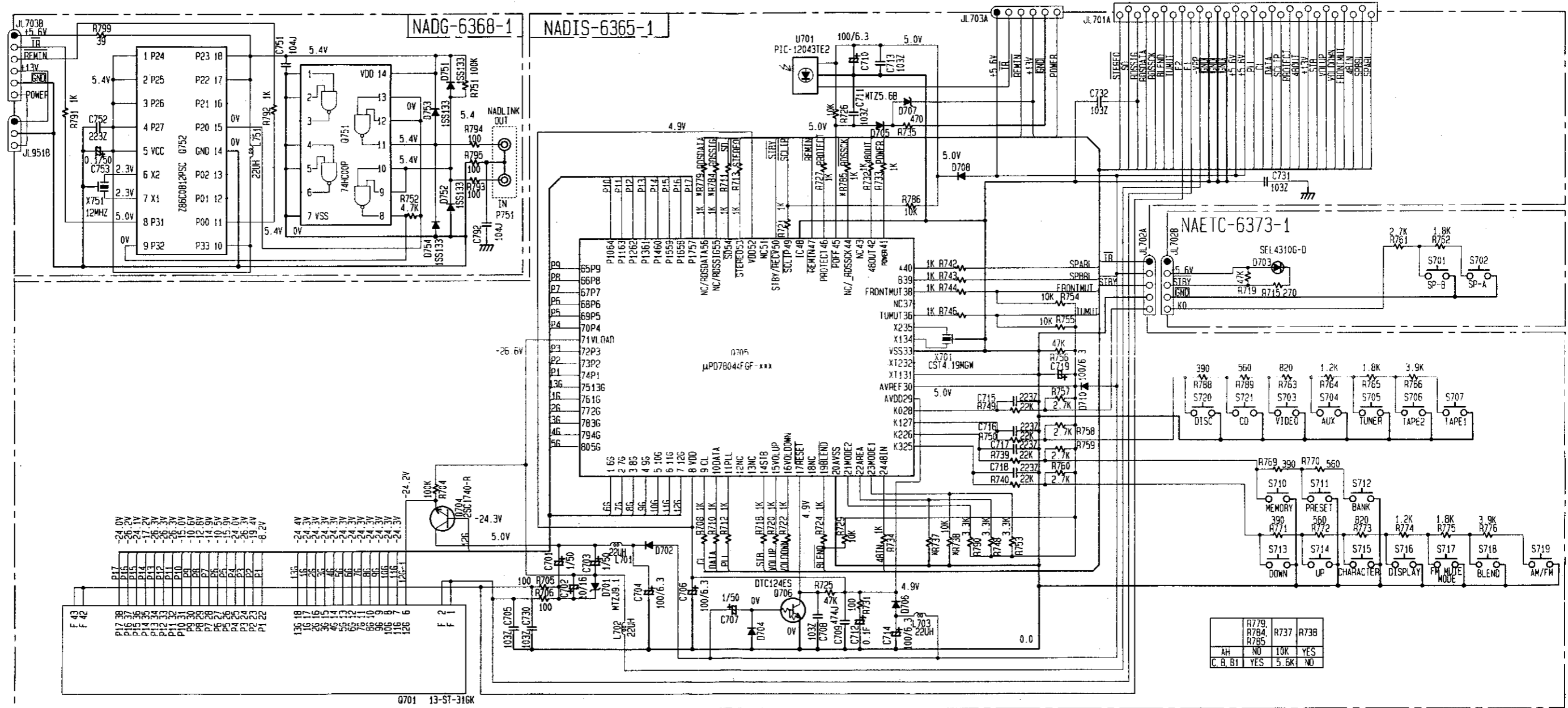

**NOTE**  
 . THE COMPONENTS IDENTIFIED BY MARK  $\Delta$  ARE CRITICAL FOR SAFETY.  
 . REPLACE ONLY WITH PART NUMBER SPECIFIED.  
 . ELECTROLYTIC CAPACITORS (E) ARE IN  $\mu$ F/1W.  
 . ALL CAPACITORS ARE IN pF/50V UNLESS OTHERWISE NOTED.  
 . EX 030 - 3pF 330 - 33pF 331 - 330pF 333 - 0.033 $\mu$ F  
 . ALL RESISTORS ARE IN OHMS 1/6 WATTS UNLESS OTHERWISE NOTED.  
 . CIRCUIT IS SUBJECT TO CHANGE FOR IMPROVEMENT.

R779	R737	R738	
R784			
R785			
AH	NO	10K	YES
C, B, B1	YES	5.6K	NO

# SCHEMATIC DIAGRAM

NARF-6366-1

NOTE  
 THE COMPONENTS IDENTIFIED BY MARK  $\Delta$  ARE CRITICAL FOR SAFETY.  
 REPLACE ONLY WITH PART NUMBER SPECIFIED.  
 ELECTROLYTIC CAPACITORS (E) ARE IN  $\mu$ F/VV.  
 ALL CAPACITORS ARE IN pF/50V UNLESS OTHERWISE NOTED.  
 EX: 030 - 3pF 330 - 33pF 331 - 330pF 333 - 0.033 $\mu$ F  
 ALL RESISTORS ARE IN OHMS 1/6 WATTS UNLESS OTHERWISE NOTED.  
 CIRCUIT IS SUBJECT TO CHANGE FOR IMPROVEMENT.

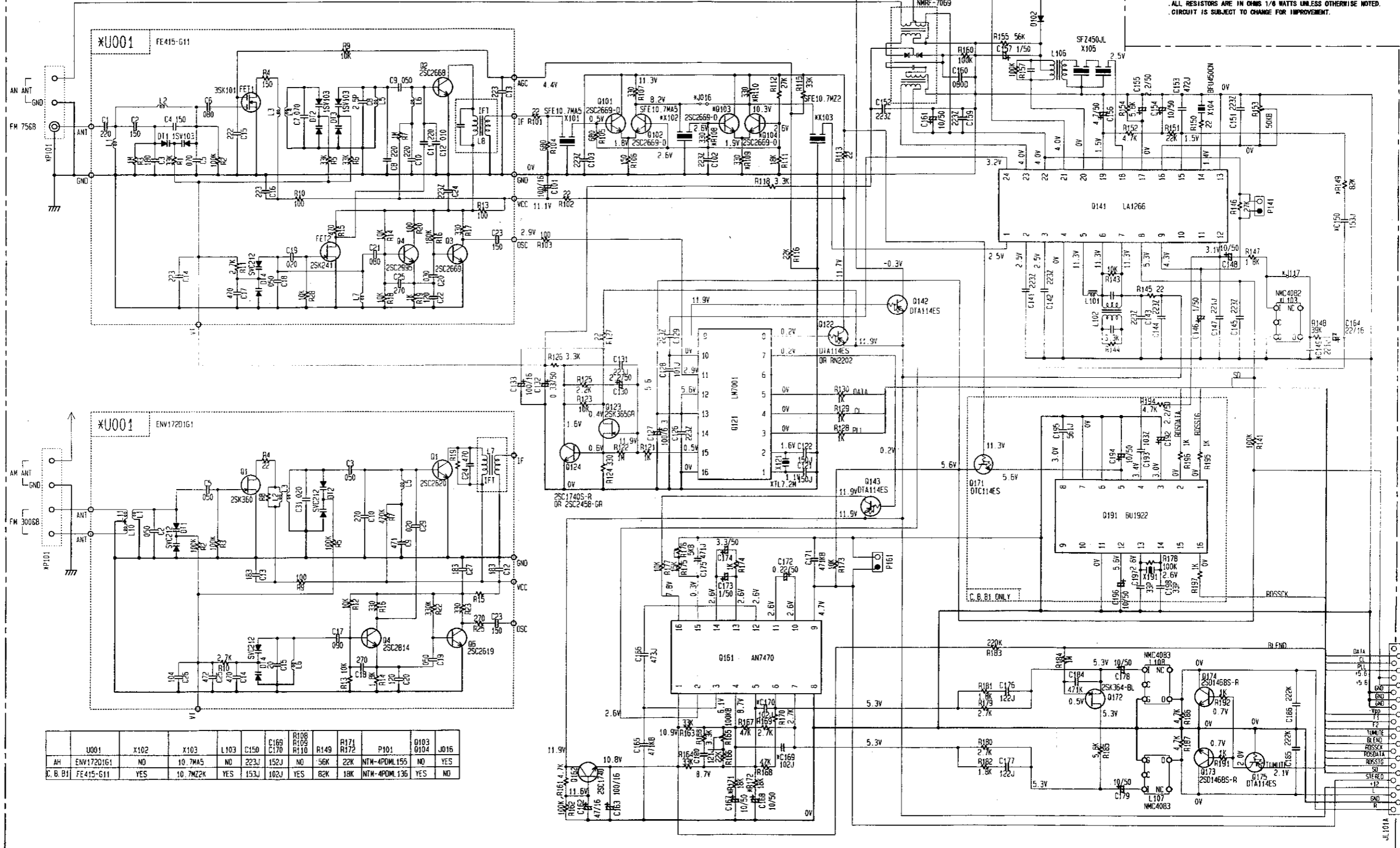

	U001	X102	X103	L103	C150	C169	R108	R109	R110	R149	R171	R172	P101	G103	G104	J016
AH	ENV17201G1	NO	10.7MA5	NO	223J	152J	NO	56K	22K	NTM-4PDM155	NO	NO	YES	NO	YES	NO
C, B, B1	FE415-G11	YES	10.7M2K	YES	153J	102J	YES	82K	18K	NTM-4PDM136	YES	NO	YES	NO	NO	NO

# MICROPROCESSOR CONNECTION DIAGRAM & TERMINAL DESCRIPTION

Pin No.	Function	I/O	Description
1	7G/6G	O	Grid control output pin. On at the high level.
2	6G/7G	O	Grid control output pin. On at the high level.
3	5G/8G	O	Grid control output pin. On at the high level.
4	4G/9G	O	Grid control output pin. On at the high level.
5	3G/10G	O	Grid control output pin. On at the high level.
6	2G/11G	O	Grid control output pin. On at the high level.
7	1G/12G	O	Grid control output pin. On at the high level.
8	VDD	-	Power supply pin. (+5V)
9	CL	O	Clock out pin. Connect to the terminals CK of function switch.
10	DATA	O	Data output pin. Connect to the terminals DATA of function switch Q301(TC9273N), electric volume IC Q491 and surround mode switch.
11	PLL	O	Chip enable output pin for PLL IC(Q121).
12		NC	
13		NC	
14	STB	O	Chip enable output pin for function switch. (Q301)
15	VOLUP	O	Volume control output pin. (Volume up)
16	VOLDOWN	O	Volume control output pin. (Volume down) Refer table 1.
17	RESET	I	System reset input pin.
18		NC	
19	BLEND	O	To blend switch (Q172). Blend : High
20	AVSS	-	Ground pin of A/D converter.
21	MODE2	I	Initializing input of operation mode.
22	AREA	I	Initializing input of frequency-area. (8-area)
23	MODE1	I	Initializing input of operation mode.
24	GND	I	To GND.
25	K3	I	Operation key connection pin.
26	K2	I	Operation key connection pin.
27	K1	I	Operation key connection pin.
28	K0	I	Operation key connection pin.
29	AVDD	-	Analogue power supply of A/D converter. (+5V)
30	AVREF	-	Reference voltage input pin of A/D converter.
31	XT1	-	Crystal connection pin for sub system clock resonator. (to ground)
32	XT2	-	Crystal connection pin for sub system clock resonator.
33	VSS	-	Ground pin.
34	X1	I	Crystal connection pin for main system clock resonator.
35	X2	I	Crystal connection pin for main system clock resonator. Connect the ceramic osc.(4.19MHz)
36	TUMUT	O	Muting output pin for tuner section.
37		NC	
38	FRONTMUT	O	Muting output pin for front amplifier.
39	SPBRL	O	Muting output pin of center SP,LS and RS at speaker-A off.
40	SPARL	O	Relay(Speaker-A) control output pin.
41	POWER	O	Power source control output pin. Power on: H
42		NC	
43		NC	
44	RDSSCK	I	To connecting the SKC terminal of IC191(RDS -modulator).
45	POFF	I	Power stoppage detector input pin.
46	PROTECT	I	Detector input pin of protection circuit.
47	REMIN	I	Remote-control signal input pin.
48	IC	-	Internal connection pin. Connect to the ground terminal.
49	SCLIP	I	To connection INH pin for sound select signal IC.
50	STBY/RCV	O	Standby and received indicator output pin.
51		NC	
52	VDD	-	Power supply pin (+5V).
53	STEREO	I	Detector input pin of FM stereo broadcast.
54	SD	I	Detector input pin of broadcast more than muting level.
55	RDSSIG	I	When RDSSEN=1: to connect the SIG-port of IC 191.
56	RDSDATA	I	When RDSSEN=1: to connect the DATA-port of IC 191.
57	P17/P4	O	Segment output pins. On at the high level.
70			
71	VLOAD	I	Pull down resistor connection pin of controller and driver of FL.
72	P3/P1	O	Segment output pins. On at the high level.
74			
75	13G/5G	O	Grid output pins. On at the high level.
80			

Table 1

Operation	Output (Vol. up)	Output (Vol. down)
Stop	H	H
Vol. Up	H	L
Vol. Down	L	H
Power	L	L

Mute off	H
Speaker-B on	H

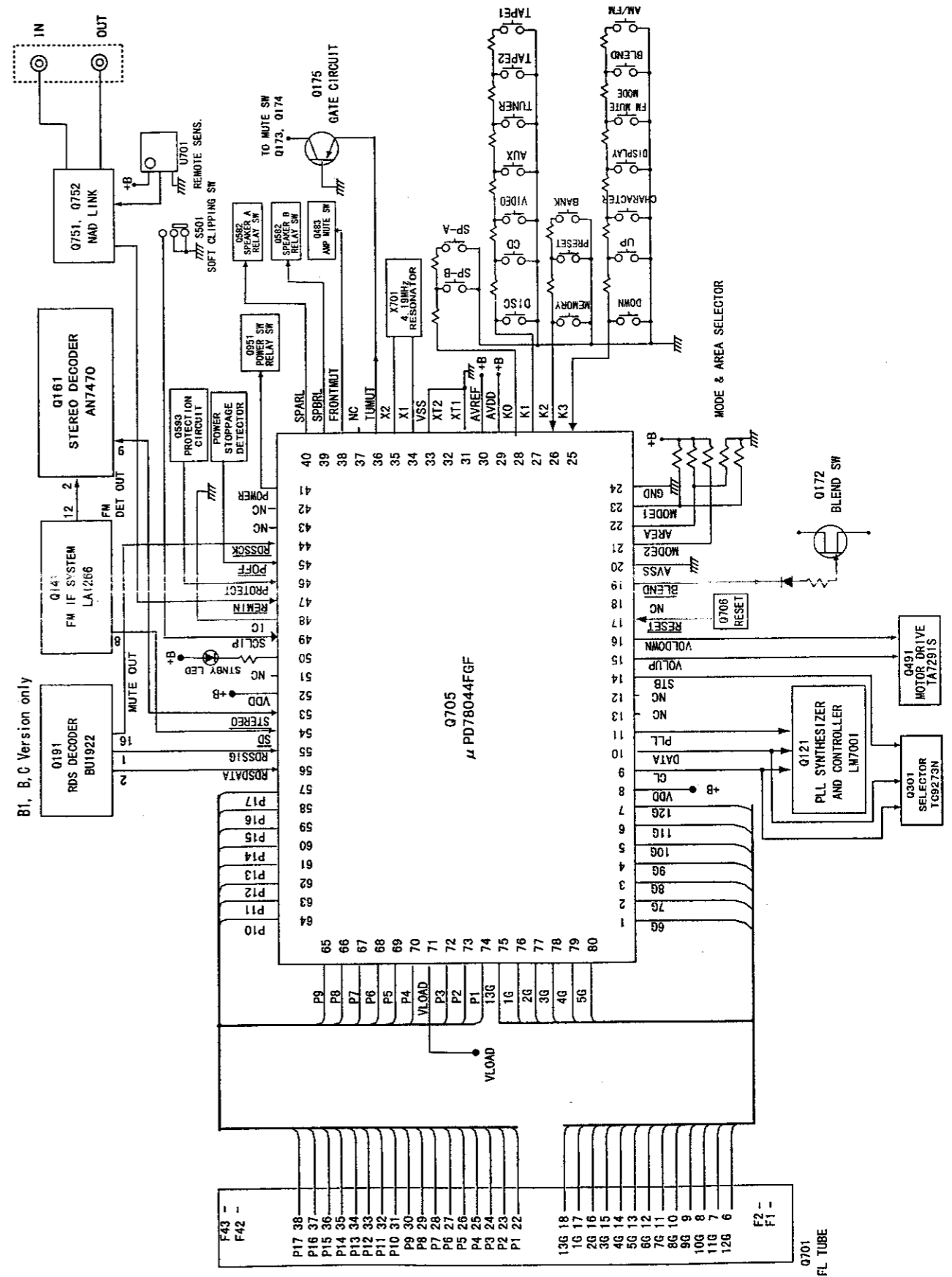

# IC BLOCK DIAGRAM

## Q161 FM STEREO MULTIPLEX DEMODULATOR AN7470

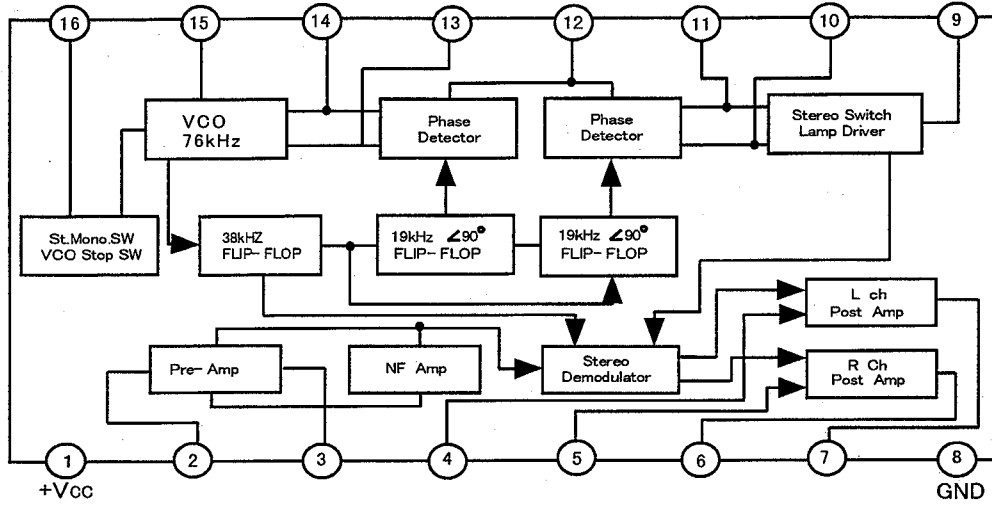

### PIN DESCRIPTION

Pin No.	Pin name	Pin No.	Pin name
1	Vcc	9	Stereo indicator and VCO freq. Monitor
2	Composite signal input	10,11	Pilot detection low-pass filter
3	Buffer Amp. Output	12	Pilot signal input
4	L Ch. Amp. Feedback	13	PLL low-pass filter
5	R Ch. Amp. Feedback	14	PLL low-pass filter
6	R Ch. Amp. Output	15	VCO RC time constant
7	L Ch. Amp. Output	16	Forced Mono. VCO killer
8	Ground		

## Q191 RDS DECODER BU1922

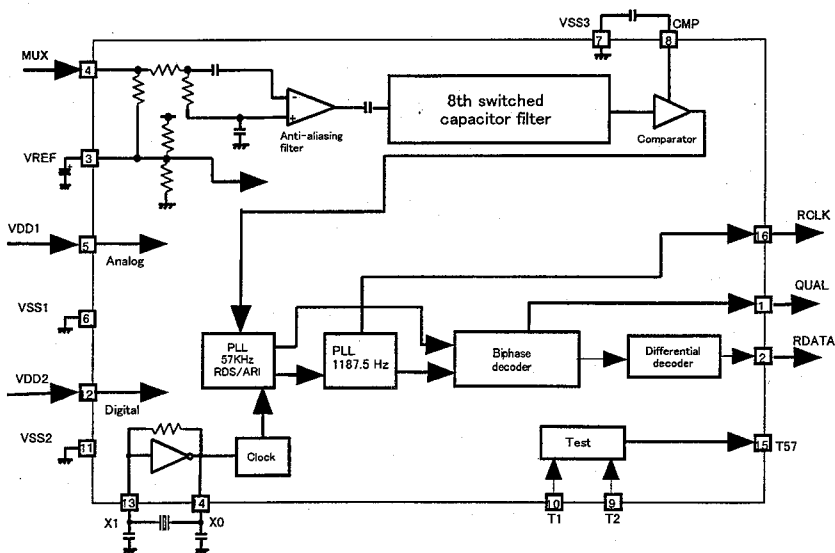

## Q121 PLL Frequency Synthesized LSI LM7001

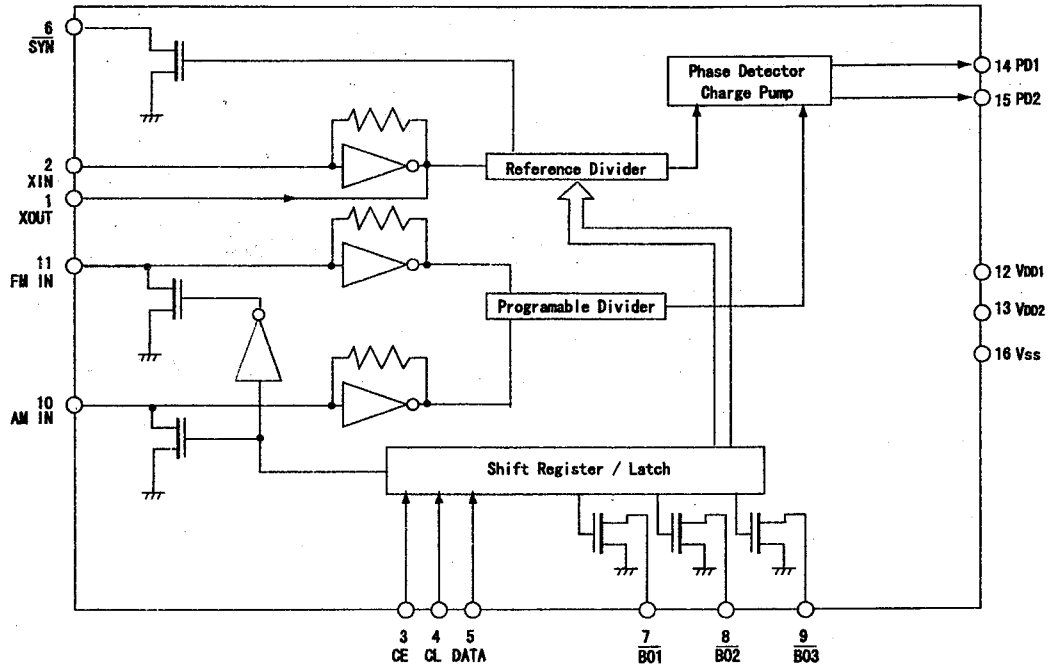

## Q141 FM IF and AM RADIO SYSTEM LA1266

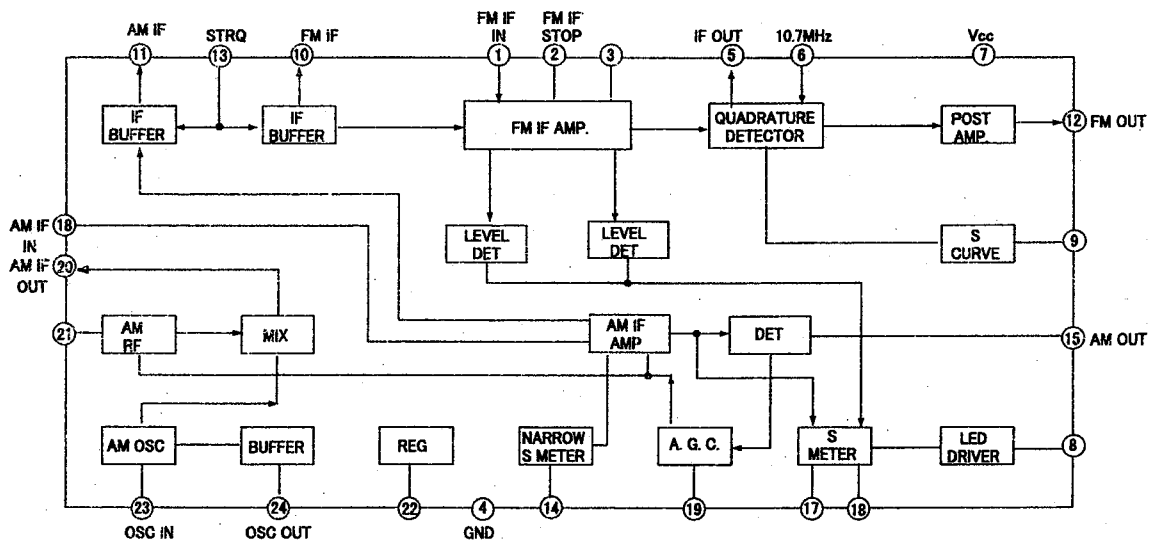



**Q491 MOTOR DRIVER IC TA7291S**

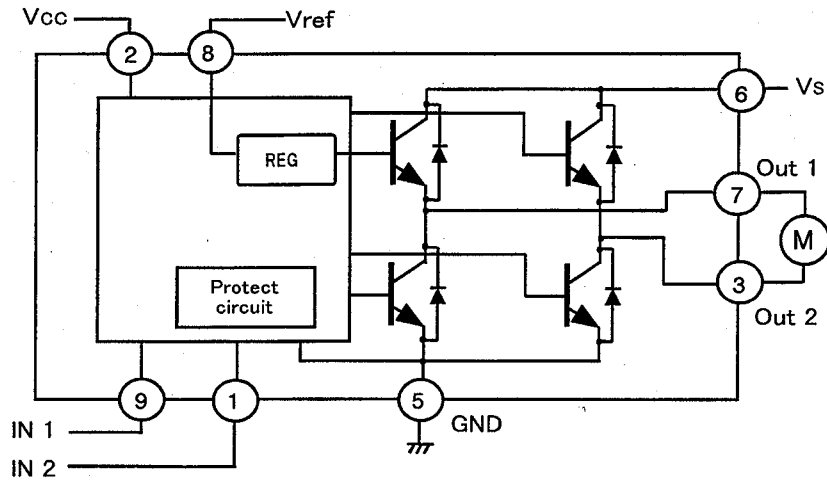

**Q301 FUNCTION SELECT IC TC9273N**

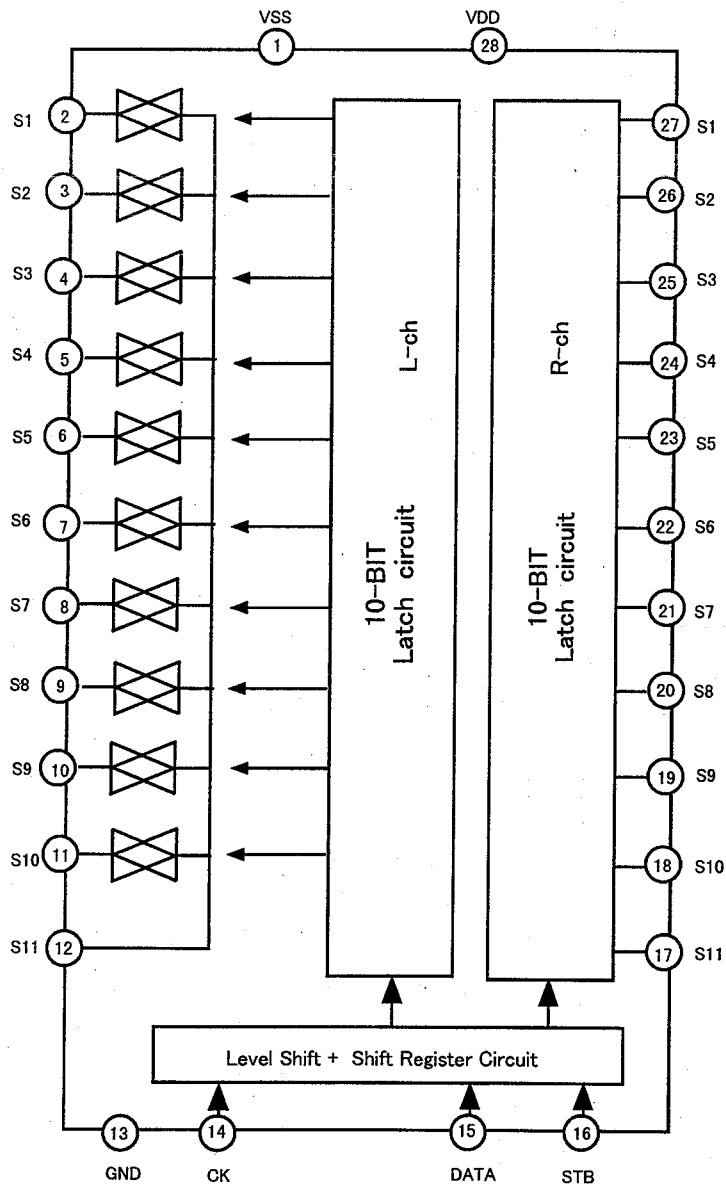

# RF SECTION BLOCK DIAGRAM

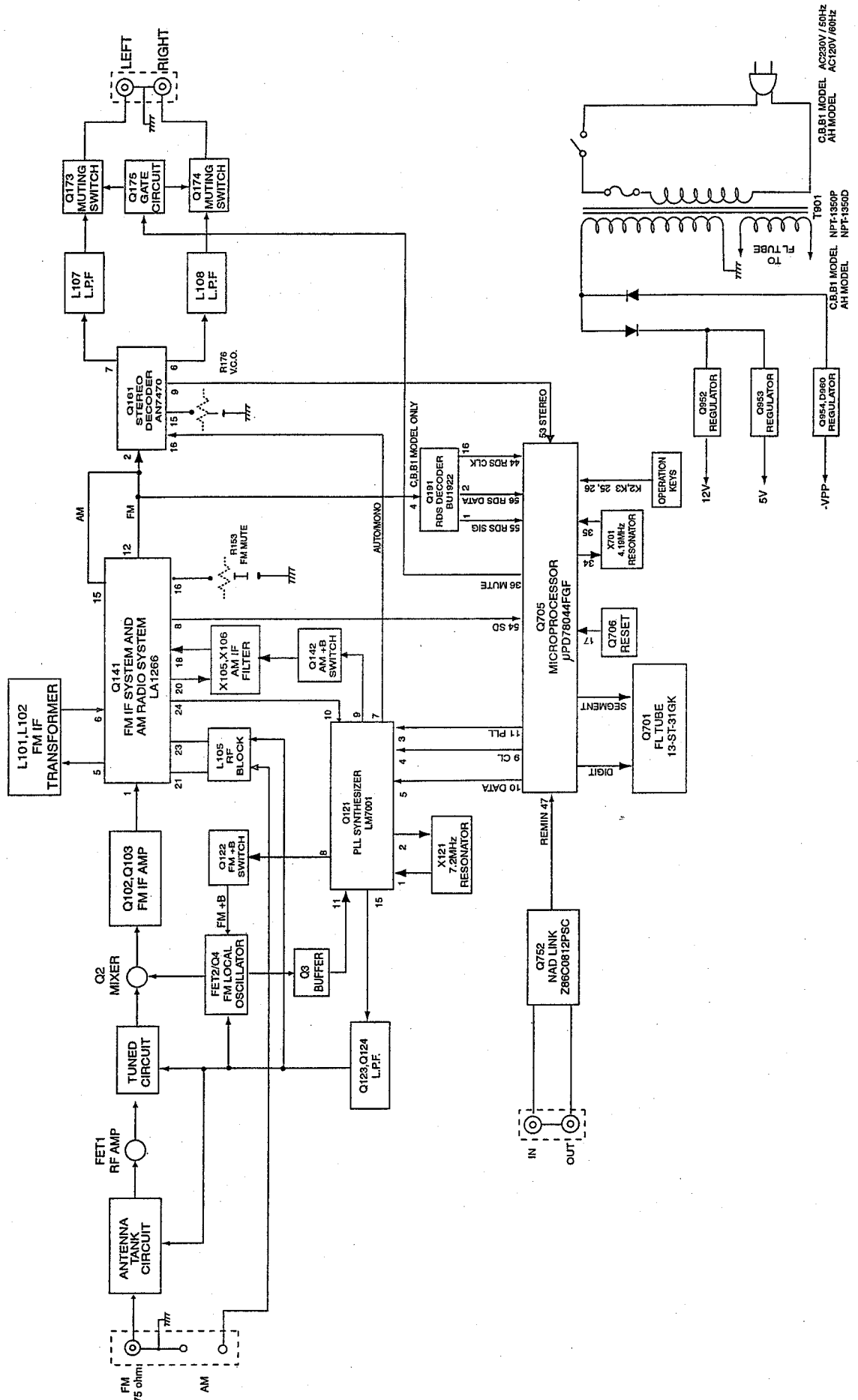

# AF SECTION BLOCK DIAGRAM

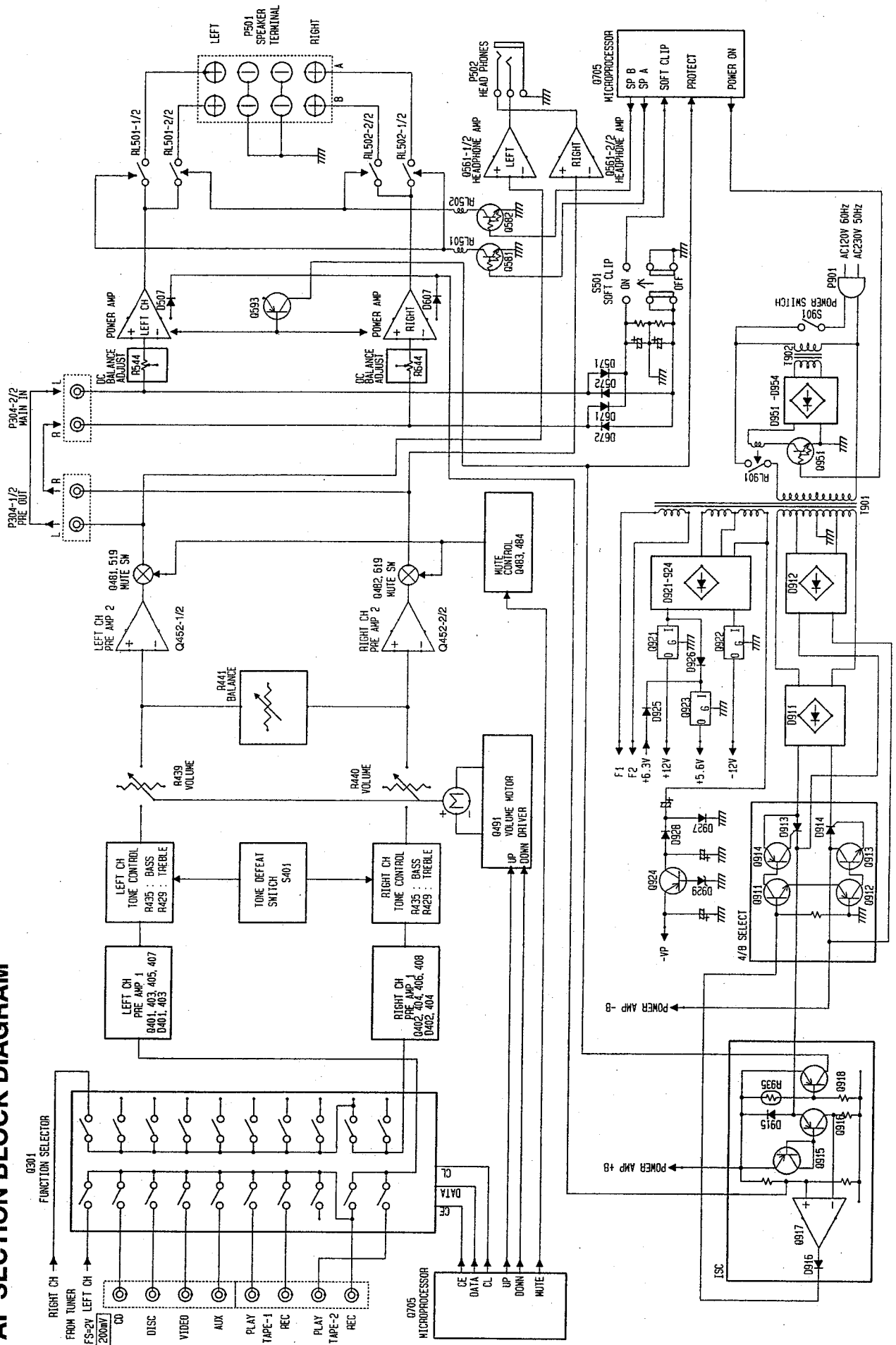

**EXPLODED VIEW**

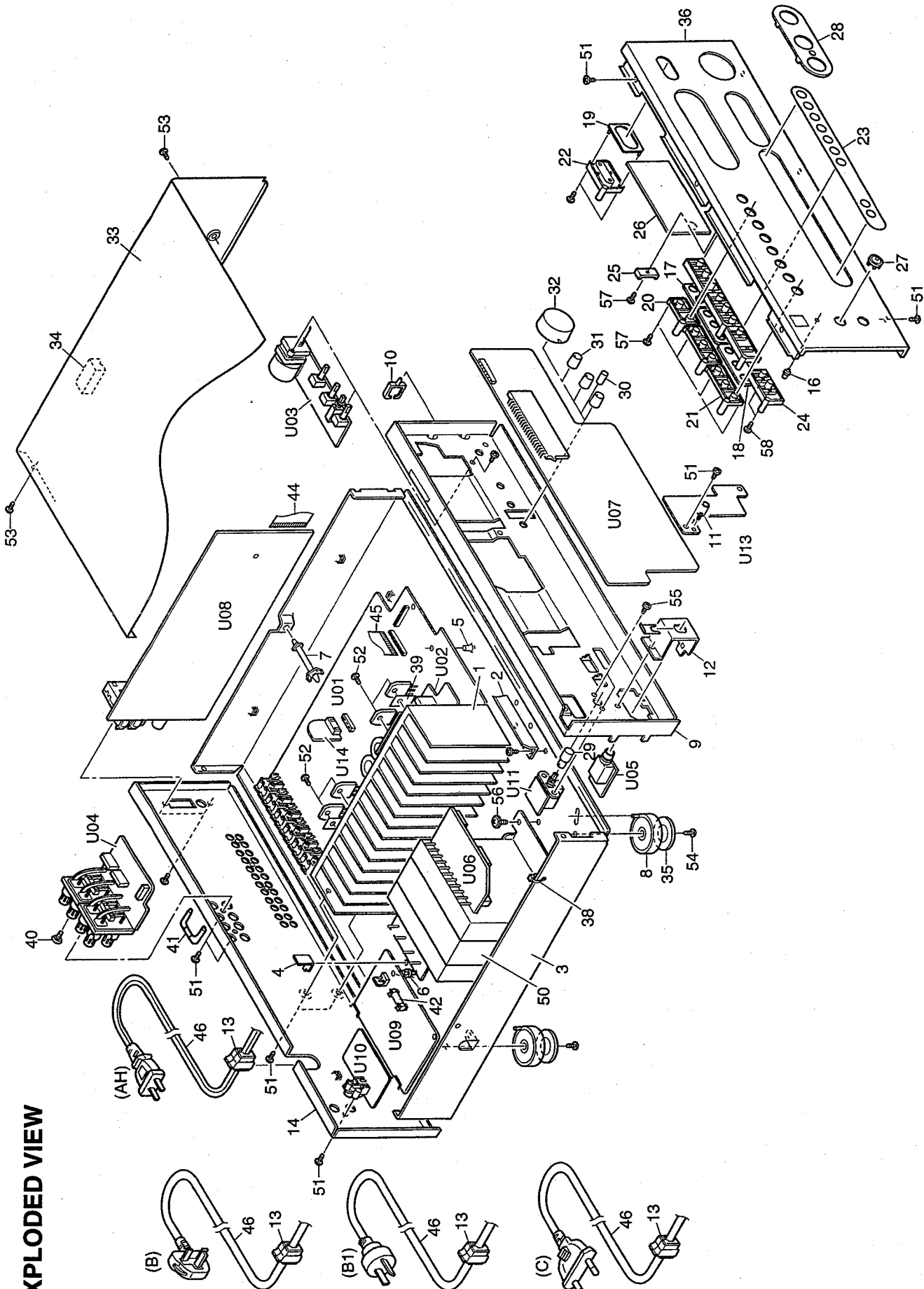

# EXPLODED VIEW PARTS LIST

REF. No.	PART No.	DESCRIPTION	Q'ty	REF. No.	PART No.	DESCRIPTION	Q'ty
1	27160417	Heatsink(Main AMP.)	1	33	28184741A	Cover	1
2	27141671	Retainer(for main heat sink)	1	34	28140265	Cushion(cover)	1
3	27100364A	Chassis	1	35	28141378	Cushion(leg)	4
4	27130745	Bracket	1	36*AH	27212011	Front panel	1
5	27191044	KGPS-8RF,Holder	2	36*B1,B,C	27212040	Front panel	1
6	27190266	KGLS-12RF,Holder	1	38	260208	Wire tie	3
7	27190369	Holder	1	39	223024	Isolation sheet	4
8	27175306	Leg	4	40*B1,B,C	880048	P-3055B-8L, Plastic rivet	8
9	27111082	Front bracket	1	41	25055436	NPLG-2P418 Plug	2
10	27300243	WS-2W, Wire clamp (Front chassis)	2	42*AH	252161	3A-UL/T-237, Fuse	1
11	27191051	Holder LED	1	42*B1,B,C	252074	2A-SE-EAK, Fuse	1
12	27141728	Retainer for Head phone	1	44	2047231012	NCFC7-231012, Flexible cable	1
13	27300750	Bushing, cord	1	45	2047292012	NCFC7-292012, Flexible cable	1
14*AH	27122492	Rear panel	1	46*AH	253279HIT	AS-UC-2#18, Power supply cord	1
14*B1,B,C	27122493	Rear panel	1	46*B	253198HIT	AS-BS, Power supply cord	1
16	28198858	Facet, Power	1	46*B1	253197HIT	AS-SAA, Power supply cord	1
17	27267996	Guide DUO	1	46*C	253193HIT	AS-CEE, Power supply cord	1
18	27267997	Guide TRIO	2	50*AH	2301354	NPT-1348D, Power transformer	1
19	27267998	Guide RACKER	1	50*B1,B,C	2301355	NPT-1348P, Power transformer	1
20	28325605	Button DUO	1	51	838130088	3TTB+8B,Self-tapping screw	50
21	28325606	Button TRIO	1	52	801433	3SMS8W,SW+14B(BC),Special screw	4
22	28325607	Button RACKER	2	53	838430088	3TTB+8B(BC), Self-tapping screw	6
23	27215307	Decorative frame	1	54	831130088	3TTW+8B,Self-tapping screw	4
24	28325608	Button, Input	1	55	838430107	3TTB+10S(BC),Self-tapping screw	2
25	27191052	Holder (for input buttons)	4	56	830440089	4TTC+8C(BC),Self-tapping screw	4
26	28191831	Clear plate	1	57	838120068 or 838220068	2TTB+6B or 2TTB+6B(Ni), Self-tapping screw	8
27	27267995	Guide, Power	1	58	838126068 or 833426068 or 834426068	2.6TTB+6B or 2.6TTP+6B(BC) or 2.6TTS+6B(BC), Self-tapping screw	9
28	27215309	Decorative frame, Tone	1				
29	28325604	Button, Power	1				
30	28325610	Button, Defeat	1				
31	28325609	Knob, Tone	3				
32	28325611	Knob, Volume	1				

REF. No.	PART No.	Q'ty	DESCRIPTION	REF. No.	PART No.	Q'ty	DESCRIPTION
U01*AH	1A786559-1A	1	NAAR-6359-1A, Main circuit PC board ass'y	U01*B1,B,C	1A786559-1B	1	NAAR-6359-1B, Main circuit PC board ass'y
U02*AH	1A786560-1A	1	NAPS-6360-1A, Sub power supply PC board ass'y	U02*B1,B,C	1A786560-1B	1	NAPS-6360-1B, Sub power supply PC board ass'y
U03*AH	1A786561-1A	1	NAAF-6361-1A, Control circuit PC board ass'y	U03*B1,B,C	1A786561-1B	1	NAAF-6361-1B, Control circuit PC board ass'y
U04*AH	1A786562-1A	1	NAETO-6362-1A, Speaker terminal PC board ass'y	U04*B1,B,C	1A786562-1B	1	NAETO-6362-1B, Speaker terminal PC board ass'y
U05*AH	1A786563-1A	1	NAETO-6363-1A, Head phone PC board ass'y	U05*B1,B,C	1A786563-1B	1	NAETO-6363-1B, Head phone PC board ass'y
U06*AH	1A786564-1A	1	NAETO-6364-1A, Transformer PC board ass'y	U06*B1,B,C	1A786564-1B	1	NAETO-6364-1B, Transformer PC board ass'y
U07*AH	1A786565-1A	1	NADIS-6365-1A, Display circuit PC board ass'y	U07*B1,B,C	1A786565-1B	1	NADIS-6365-1B, Display circuit PC board ass'y
U08*AH	1A786566-1A	1	NARF-6366-1A, RF circuit PC board ass'y	U08*B1,B,C	1A786566-1B	1	NARF-6366-1B, RF circuit PC board ass'y
U09*AH	1A786567-1A	1	NAPS-6367-1A, Power supply PC board ass'y	U09*B1,B,C	1A786567-1B	1	NAPS-6367-1B, Power supply PC board ass'y
U10*AH	1A786568-1A	1	NADG-6368-1A, NAD link PC board ass'y	U10*B1,B,C	1A786568-1B	1	NADG-6368-1B, NAD link PC board ass'y
U11*AH	1A786569-1A	1	NASW-6369-1A, Power switch PC board ass'y	U11*B1,B,C	1A786569-1B	1	NASW-6369-1B, Power switch PC board ass'y
U13*AH	1A786573-1A	1	NAETO-6373-1A, LED PC board ass'y	U13*B1,B,C	1A786573-1B	1	NAETO-6373-1B, LED PC board ass'y
U14*AH	1A786513-1A	1	NAETO-6513-1A, Sub PC board ass'y	U14*B1,B,C	1A786513-1B	1	NAETO-6513-1B, Sub PC board ass'y

NOTE: THE COMPONENTS IDENTIFIED BY MARK  $\Delta$  ARE CRITICAL  
FOR RISK OF FIRE AND ELECTRIC SHOCK.  
REPLACE ONLY WITH PART NUMBER SPECIFIED.

NOTE:  
 <AH>: U.S.A., Canadian model only  
 <B>: U.K. model only  
 <B1>: Australian model only  
 <C>: European model only



# WIRING DIAGRAM

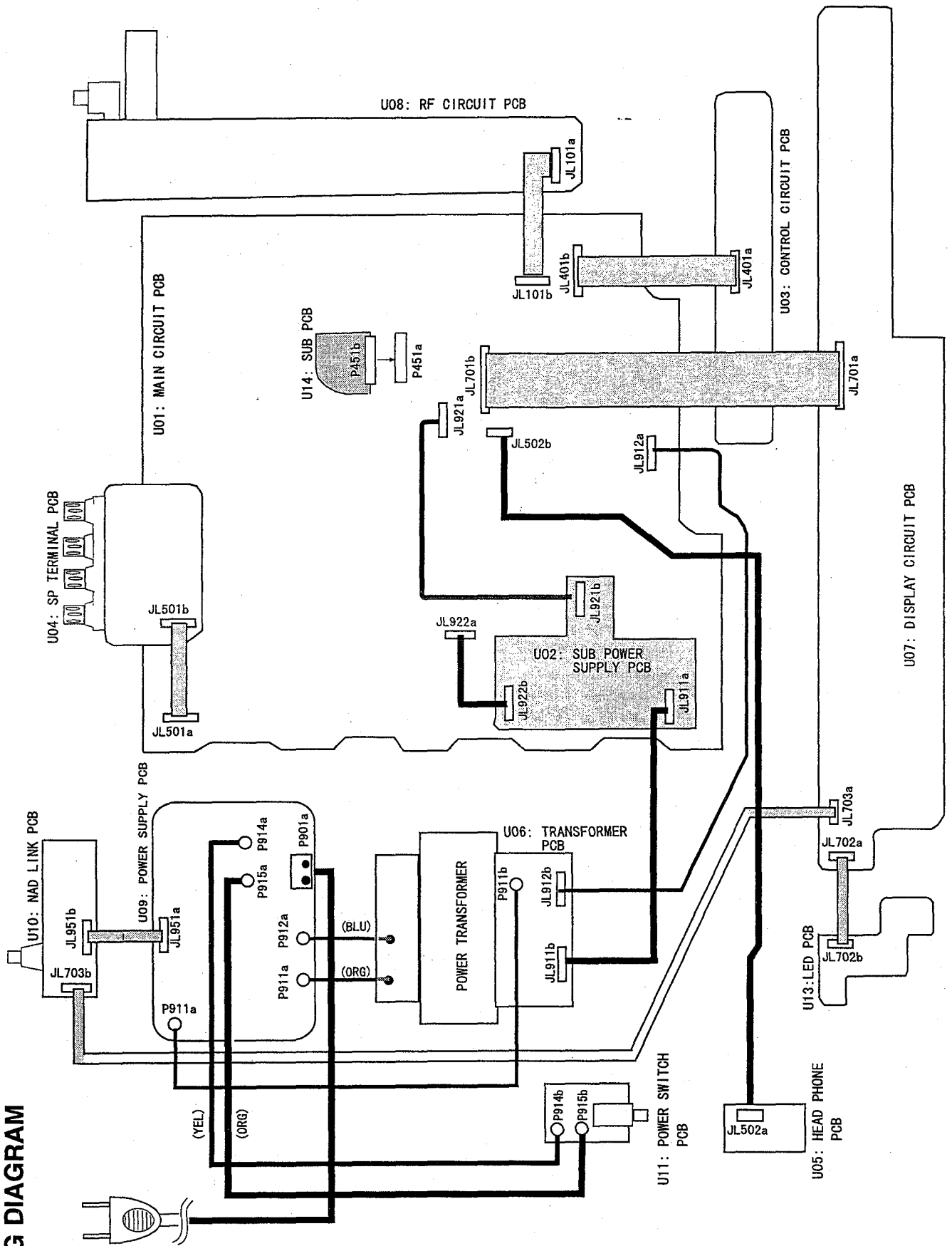

# ELECTRICAL PARTS LIST

NOTE: Replacement of the transistor of mark \*, if necessary, must be made from the same beta group (HFE) as the original type.

REF. No.	PART No.	DESCRIPTION	REF. No.	PART No.	DESCRIPTION
<b>U14: Sub PC board (NAETC-6513)</b>			<b>Coils</b>		
<b>Capacitors</b>			L501,L601	231176S	S-1.3C
C413	354764709	47 $\mu$ F,35V,Elect.	L502,L503,L602,	5597-45502	Ferrite Core
C414	354764709	47 $\mu$ F,35V,Elect.	L603		
<b>IC</b>			<b>Ics</b>		
Q452	22240656	NE5532AN	Q301	22240881	TC9273N-010
<b>Others</b>			Q491	22240239	TA7291S
P451b	25055912	NPLG-8P865	Q561	22240293 or	NJM4558L-D or
<b>U01: Main circuit PC board (NAAR-6359)</b>				22240247	BA15218N
<b>Capacitors</b>				22241254	NJM431L
C457,C458,C468,	354741019	100 $\mu$ F,16V,Elect.	Q509,Q510,Q609,		
C469,C473,C474,			Q610		
C593			Q921	222780125	78M12HF
C501,C601	354742209	22 $\mu$ F,16V,Elect.	Q921a	27160209	HEAT-SINK(RAD-67)
C409-C412,	354744709	47 $\mu$ F,16V,Elect.	Q921b	838430107	3TTB+10S(BC),
C571,C572					Self-tapping screw
C418	354762209	22 $\mu$ F,35V,Elect.	Q922	222790125	79M12HF
C507,C508,C607,	354764709	47 $\mu$ F,35V,Elect.	Q922a	27160429	Heat sink
C608			Q922b	838430107	3TTB+10S(BC),
C451,C452	354780109	1 $\mu$ F,50V,Elect.			Self-tapping screw
C521,C522,C561,	354781009	10 $\mu$ F,50V,Elect.	Q923	222780565JRC	78M56(NJM78M56FA)
C562,C621,C622,			<b>Transistors</b>		
C661,C662,C931			Q401,Q402	2214736 or	2SK369-BL or
C925-C928,				2214735	2SK369-GR
C523,C524,C623,	354781019	100 $\mu$ F,50V,Elect.	Q403,Q404,Q407,	2211085	2SA872A-E
C624,C930			Q408		
C929	354784709	47 $\mu$ F,50V,Elect.	Q405,Q406	2215116	2SC1775-F
C504,C604	374721015	100pF $\pm$ 10%,50V,Plastic	Q481,Q482	2215196	2SK364-BL
C403,C404,C417,	374721044	0.1 $\mu$ F $\pm$ 5%,50V,Plastic	Q483	2212600	DTA124ES
C423,C511			Q484	2213290	DTC114ES
C569,C570,C611,	374721044	0.1 $\mu$ F $\pm$ 5%,50V,Plastic	Q501,Q504,Q601,	2211793	2SA992-E
C942,C943			Q604		
C453,C454*AH	374722215	220pF $\pm$ 10%,50V,Plastic	Q502,Q503,Q602,	2211733	2SC1845-E
C483,C484	374722215	220pF $\pm$ 10%,50V,Plastic	Q603		
C459-C462	374722224	2200pF $\pm$ 5%,50V,Plastic	Q505,Q512,Q605	2211455	2SA1015-GR
*B1,B,C			Q506,Q606,Q913,	2211255	2SC1815-GR
C917,C918	3504344	10000 $\mu$ F,50V,Elect.	Q612,Q924		
C612,C512	354722229	2200 $\mu$ F,6.3V,Elect.	Q507,Q508,Q514,	2203000	2SA1930
C924	354761029	1000 $\mu$ F,35V,Elect.	Q607,Q614		
C923	354763329	3300 $\mu$ F,35V,Elect.	Q511,Q611,Q611	2212654 or	2SC3421-Y or
<b>Diodes</b>				2212653	2SC3421-O
D401-D404,	223163	1SS133	Q511a	27160416A	(TR) Heat sink
D501-D507,			Q511b	838430107	3TTB+10S(BC),
D571-D574,					Self-tapping screw
D601-D607,			Q611a	27160416A	Heat sink (TR)
D671,D672			Q611b	838430107	3TTB+10S(BC),
D921-D928	22380260 or	RL1N4003 or	Q513,Q608,Q613	2203010	2SC5171
	22380035	GP104003E	Q515,Q615	2202833 or	* 2SA1962-O or
D929	224472704	MTZJ27D Zener		2202832	2SA1962-R
<b>Jumper leads</b>			Q516,Q616	2202843 or	* 2SC5242-O or
JL401a	25051113	NSCT-9P900		2202842	2SC5242-R
JL501a	25051112	NSCT-8P899	Q517,Q617,Q518,	2211354 or	2SA949-Y or
JL502b	25055624	NPLG-3P586	Q618	2211353	2SA949-O
JL701b	25051836 or	NSCT-29P1623 or	Q519,Q619	2213631	RN1241-A
	25050969	NSCT-29P756	Q591,Q691	2211733 or	2SC1845-E or
JL921a	25051088	NSCT-4P875		2211732	2SC1845-F
JL922b	25050271	NSCT-7P99	Q593	2211792 or	2SA992-E or
JL101b	25050963 or	NSCT-23P750 or		2211793	2SA992-F
	25051830	NSCT-23P1617	Q595,Q596	2213284	2SC1740S-R
JL912a	25051109	NSCT-5P896			

REF. No.	PART No.	DESCRIPTION	REF. No.	PART No.	DESCRIPTION
<b>Resistors</b>			JL921b	25055625	NPLG-4P587
R467,R468	415421013	100 $\Omega$ $\pm$ 2%, 1/4W, Carbon	JL922a	25051111	NSCT-7P898
R519,R520,R619, R620	443521014	$\Delta$ 100 $\Omega$ $\pm$ 5%, 1/2W, Metal oxide	<u>Control circuit PC board (NAAF-6361)</u>		
R521,R522,R621, R622	4400044F	$\Delta$ 2.7k $\Omega$ $\pm$ 5%, 5W, Metal oxide	<b>Capacitors</b>		
R533,R538,R633, R638	453530104	$\Delta$ 1 $\Omega$ $\pm$ 5%, 1/2W, Metal	C421,C422	374722234	0.022 $\mu$ F $\pm$ 5%, 50V, Plastic
R534	5210255T	N06HR200BC, Trimming	C424	374721044	0.1 $\mu$ F $\pm$ 5%, 50V, Plastic
R535,R536,R545, R548,R636,R645, R648	443524704	$\Delta$ 47 $\Omega$ $\pm$ 5%, 1/2W, Metal oxide	C425,C426	374724724	4700pF $\pm$ 5%, 50V, Plastic
R537,R637	4500030	$\Delta$ MPC722-5WK-0.1, Metal plate	C427,C428	374722244	0.22 $\mu$ F $\pm$ 5%, 50V, Plastic
R539,R639	453630824	$\Delta$ 8.2 $\Omega$ $\pm$ 5%, 1/2W, Metal	C429,C430	374721054	1 $\mu$ F $\pm$ 5%, 50V, Plastic
R540,R640	453530334	$\Delta$ 3.3 $\Omega$ $\pm$ 5%, 1/2W, Metal	C431,C432	354780229	2.2 $\mu$ F, 50V, Elect.
R541,R641	443625614	$\Delta$ 560 $\Omega$ $\pm$ 5%, 1W, Metal oxide	<b>Resistors</b>		
R544,R644	5210258	N06HR1KBC, Trimming	R429,R435	5132447	N14RGLC10KA25F, Variable
R634	5210255	N06HR200BC, Trimming	R439	5142445	N16RGL20KBTP30F, Variable
<b>Switches</b>			R441	5132446	N14RGLC20KMN25F, Variable
S501	25065286	NSS-22112	<b>Switches</b>		
<b>Jacks</b>			S401	25035698	NPS-123-L661
P302,P303	25045565 or 25045508	NPJ-6PDBL380 or NPJ-6PDBL323	<b>Others</b>		
P304	25045356	NPJ-4PDBL202	JL401b	25050273	NSCT-9P101
<b>Others</b>			<u>Speaker terminal PC board (NAETC-6362)</u>		
P451a	25052137	NSCT-8P2035 Socket	<b>Capacitors</b>		
P531,P631	25055038	NPLG-2P29 Plug	C563,C564, C663,C664	374721034	0.01 $\mu$ F $\pm$ 5%, 50V, Plastic
P301	25045356	NPJ-4PDBL202 Pin jack	<b>Diodes</b>		
P923	72120080505	1007#24 .2/7HAND B	D581,D582	223163	1SS133
E921	260224	CP-1S Clamp	<b>Terminals</b>		
<u>Sub power supply PC board (NAPS-6360)</u>			P501	25060125	NTM-8PDMN058
<b>Capacitors</b>			<b>Transistors</b>		
C919,C920	354781009	10 $\mu$ F, 50V, Elect.	Q581,Q582	2213640	DTC123JS
C933	374721044	0.1 $\mu$ F $\pm$ 5%, 50V, Plastic	<b>Relays</b>		
<b>Diodes</b>			RL501,RL502	25065517	$\Delta$ NRL-2P5A-DC24-098
D911	22380281	RS604	<b>Other</b>		
D912	22380274 or 22380038	RS603M or RBV602	JL501b	25050272	NSCT-8P100
D912a	27160419	(SCR) Heat sink	<u>Head phone PC board (NAETC-6363)</u>		
D912b	838430107	3TTB+10S(BC), Self-tapping	<b>Capacitors</b>		
D913,D914	226065	SF8JZ47	C567,C568*B1,B,C	374721034	0.01 $\mu$ F $\pm$ 5%, 50V, Plastic
D915	22380012	HER303F	<b>Terminal</b>		
D916	223163	1SS133	P502	25045255	YKB26-5009 Jack
<b>Transistors</b>			<b>Others</b>		
Q594	2211792 or 2211793	2SA992-E or 2SA992-F	JL502a	25051087	NSCT-3P874
Q911	2211255	2SC1815-GR	<u>Transformer PC board (NAETC-6364)</u>		
Q912,Q914-Q916	2211455	2SA1015-GR	<b>Capacitors</b>		
<b>ICs</b>			C911-C914	374731044	0.1 $\mu$ F $\pm$ 5%, 100V, Plastic
Q917	22240293	NJM4558L-D	<b>Resistors</b>		
<b>Resistors</b>			R911,R912	453530224	$\Delta$ 2.2 $\Omega$ $\pm$ 5%, 1/2W, Metal
R923	4000116	$\Delta$ MPC74-5WK-0.1, Metal plate	<b>Others</b>		
R935	4000150	PTH9M04BC222TS2F333 Thermistor	JL911b	25050285	NSCT-8P113
<b>Others</b>			JL912b	25050282	NSCT-5P110
JL911a	25051112	NSCT-8P899	<u>Display circuit PC board (NADIS-6365)</u>		
			<b>Capacitors</b>		
			C701,C703,C707	355780109	1 $\mu$ F, 50V, Elect.
			C702	355741009	10 $\mu$ F, 16V, Elect.
			C704,C706,C710, C714,C719	354721019	100 $\mu$ F, 6.3V, Elect.
			C709	375524744	0.47 $\mu$ F $\pm$ 5%, 50V, Plastic
			C712	3000076 or 3000078	EECS5R5T104 or DX-5R5L104
			<b>Diodes</b>		
			D701	224470913	MTZJ9.1C Zener
			D702,D704,D706, D708,D710	223163	1SS133
			D707	224470562	MTZJ5.6B Zener
			<b>Coils</b>		
			L701-L703	233454M022	NCH-1452 022M

REF. No.	PART No.	DESCRIPTION	REF. No.	PART No.	DESCRIPTION
<b>Fluorescent tube</b>			<b>Coils</b>		
Q701	212194	13-ST-31GK FL tube	L101	233469	NFIF-4087
Q701a	27191056	(FL) Holder	L102	233470	NFIF-4088
<b>Ics</b>			L103*B1,B,C	232164	NMC-4082
Q705	22241255	MPD78044FGF-114	L105	231226	NMRF-7069
<b>Transistors</b>			L106	232166	NMIF-4089
Q704	2213284	2SC1740S-R	L107,L108	232165	NMC-4083
Q706	2213160	DTC124ES	<b>Terminals</b>		
<b>Switches</b>			P101*B1,B,C	25060117	NTM-2PDML051 Antenna
S703-S707, S710-S721	25035675	NPS-111-111-S628	P101*AH	25060233	NTM-4PDML155 Antenna
<b>Ceramic filter</b>			P101a:B1,B,C	27150397	
X701	3010163	CST4.19MGW,Ceramic	P101a*AH	27150432	
<b>Others</b>			<b>Ics</b>		
JL701a	25051873 or 25050935	NSCT-29P1660 or NSCT-29P722 Socket	Q121	22241076 or 22240090	LM7001J or LM7001
JL702a	25051089	NSCT-5P876 wire holder	Q141	22240039	LA1266
JL703a	25051090	NSCT-6P877 wire holder	Q161	22240242	AN7470
U701	24130011	PIC-12043TE2 Remote sensor	Q191*B1,B,C	22241124	BU1922
<b>RF circuit PC board (NARF-6366)</b>			<b>Transistors</b>		
<b>Capacitors</b>			Q101,Q102	2215063	2SC2669-0
C127	354721019	100 $\mu$ F,6.3V,Elect.	Q103,Q104*B1,B,C	2215063	2SC2669-0
C101,C133,C163	354741019	100 $\mu$ F,16V,Elect.	Q122,Q142,Q143	2213510 or 2214350	DTA114ES or RN2202
C164	354742209	22 $\mu$ F,16V,Elect.	Q123	2212445	2SK365-GR
C162	354744709	47 $\mu$ F,16V,Elect.	Q124,Q162	2213284	2SC1740S-R
C130,C155	354780229	2.2 $\mu$ F,50V,Elect.	Q171*B1,B,C	2213290 or 2214230	DTC114ES or RN1202
C174	354780339	3.3 $\mu$ F,50V,Elect.	Q172	2215196	2SK364-BL
C156	354780479	4.7 $\mu$ F,50V,Elect.	Q173,Q174	2215024	2SD1468S-R
C148,C154,C161, C167,C168	354781009	10 $\mu$ F,50V,Elect.	Q175	2213510	DTA114ES
C172	354782299	0.22 $\mu$ F,50V,Elect.	<b>Resistors</b>		
C132	354783399	0.33 $\mu$ F,50V,Elect.	R153	5210265	N06HR50KBC,Trimming
C146,C157,C173	355780109	1 $\mu$ F,50V,Elect.	R165	5210266	N06HR100KBC,Trimming
C175	370134714	470pF $\pm$ 5%,100V,Plastic	R176	5210261	N06HR5KBC,Trimming
C169,C170 *B1,B,C	374721024	1000pF $\pm$ 5%,50V,Plastic	<b>Frontend</b>		
C176,C177	374721224	1200pF $\pm$ 5%,50V,Plastic	U001*B1,B,C	240089	FE415-G11
C169,C170*AH	374721524	1500pF $\pm$ 5%,50V,Plastic	U001*AH	240098	ENV172D1G1
C150*B1,B,C	374721534	0.015 $\mu$ F $\pm$ 5%,50V,Plastic	<b>Resonators</b>		
C131	374722234	0.022 $\mu$ F $\pm$ 5%,50V,Plastic	X101	3010071	SFE-10.7MA5 RED
C150*AH	374722234	0.022 $\mu$ F $\pm$ 5%,50V,Plastic	X191*B1,B,C	3010203	AF6146CG,Crystal
C153	374724724	4700pF $\pm$ 5%,50V,Plastic	X102*B1,B,C	3010071	SFE-10.7MA5 RED
C166	374724734	0.047 $\mu$ F $\pm$ 5%,50V,Plastic	X103*AH	3010071	SFE-10.7MA5 RED
C178,C179	354781009	10 $\mu$ F,50V,Elect.	X103*B1,B,C	3010130	SFE10.7M2ZK
C192*B1,B,C	354780229	2.2 $\mu$ F,50V,Elect.	X104	5671-7137C	BFU450C4N
C194,C196 *B1,B,C	354781009	10 $\mu$ F,50V,Elect.	X105	3010123	SFZ450JL
C195	374725614	560pF $\pm$ 5%,50V,Plastic	X121	3010141	XTL-7.2M,Crystal OSC.
<b>Diodes</b>			<b>Others</b>		
D102,D705	223163	1SS133	P141,P161	25055038	NPLG-2P29
<b>Sockets</b>			<b>Power supply PC board (NAPS-6367)</b>		
JL101a	25051867 or 25050929	NSCT-23P1654 or NSCT-23P716	<b>Capacitors</b>		
			C951	354742219	220 $\mu$ F,16V,Elect.
			C902	3500191	DE7150F-103M
			<b>Diodes</b>		
			D951-D954	22380032 or 22380260 or 22380035	1SR139-100 or RL1N4003 or GP104003E
			D955	223163	1SS133
			<b>Transistors</b>		
			Q951	2213640	DTC123JS
			<b>Resistors</b>		
			R901*AH	431533355	$\Delta$ 3.3M $\Omega$ , 1/2W,Solid

REF. No.	PART No.	DESCRIPTION
<b>Resistors</b>		
RL901	25065515	⚠ NRL-1P5A-DC12-096
R951	453530824	⚠ 8.2 Ω ± 5%, 1/2W, Metal
<b>Transformers</b>		
T902*B1,B,C	2300671A	⚠ NPT-1111P, Power
T902*AH	2301258	⚠ NPT-1294D, Power
<b>Others</b>		
F901a	25050065	YSH403T Fuse holder
F901b*AH	29360684	Fuse label
JL951a	25051107	NSCT-3P894 Jumper lead
P901a	25055675	NPLG-2P631 Plug for AC cord

**NAD link PC board (NADG-6368)**

<b>Capacitors</b>		
C751,C792	374721044	0.1 μ F ± 5%, 50V, Plastic
C753	354781099	0.1 μ F, 50V, Elect.
D751-D754	223163	1SS133
<b>Ics</b>		
Q751	222740005	74HC00P
Q752	22241266	Z86C0812PSC-R2536
<b>Others</b>		
L751	233454K220	NCH-1452 220K
P751	25045568	NPJ-2PDY383 Pin jack
JL703b	25055627	NPLG-6P589
JL951b	25050267	NSCT-3P95
X751	3010252	CST12.0MTW, Ceramic OSC.

**Power switch PC board (NASW-6369)**

C901	3500191	⚠ DE7150F-103M
C901a	27301216	⚠ SB1925A Cover
S901	25035550	⚠ NPS-111-L512P Switch

**LED PC board (NAETC-6373)**

D703	225292D	SEL4310G-D LED
JL702b	25051089	NSCT-5P876 Wire holder
S701,S702	25035675	NPS-111-111-S628 Speakers switch

# PACKING DIAGRAM

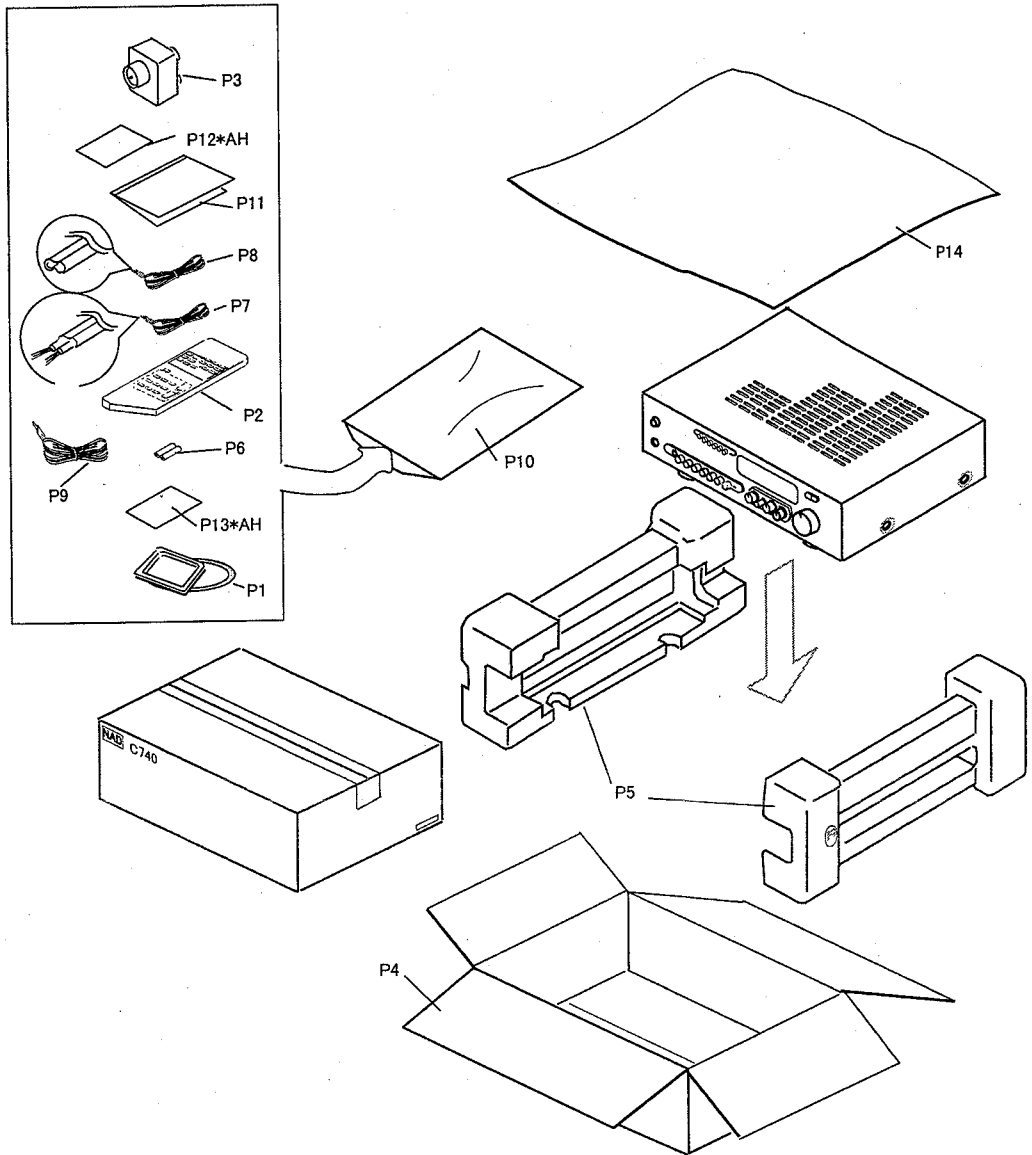

## PARTS LIST

REF. No.	PART No.	Q'ty	DESCRIPTION	REF. No.	PART No.	Q'ty	DESCRIPTION
P1	232140	1	NMA-3057, AM loop antenna	P10	29100097-1A	1	350*250, Styrene bag
P2	24140380S	1	RC-450S, Remote control	P11	29342608	1	Instruction manual
P3*AH	25065462	1	YAE21-0237, Antenna adapter	P12*AH	29355233	1	Instruction sheet
P4*AH	29053323	1	Carton box	P13*AH	29365078	1	Warranty card
P4*B1,B,C	29053353	1	Carton box	P14	29100034-1	1	Styrene bag
P5	29091858	1	Pad ass'y				
P6	3010124	2	UM-4, Battery				
P7*AH	292111	1	FM antenna				
P8*B1,B,C	292112	1	FM antenna				
P9	2010317	1	NAD link cable				

NOTE: <AH> : U.S.A., Canadian model only  
 <B> : U.K. model only  
 <B1> : Australian model only  
 <C> : European model only

Proprietary information for servicing purposes only. The information herein may not be used commercially without the prior written agreement of NAD Electronics Ltd, London, England.



# Running change Information

C740 have made a modification. Please refer following information and the serial numbers.

Serial number :	0877401001 ~ 0877401500 <AH>	500 sets
	0867400101 ~ 0867401000 <C>	900 sets
	0877401501 ~ 0877401600 <C>	100 sets
	0877401601 ~ 0877402500 <C>	900 sets

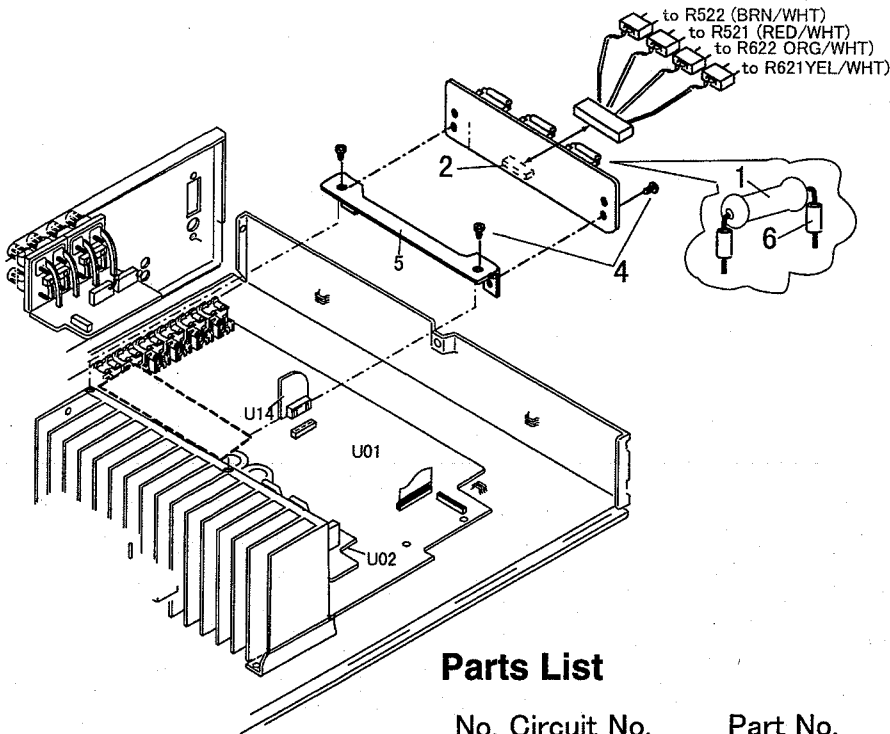
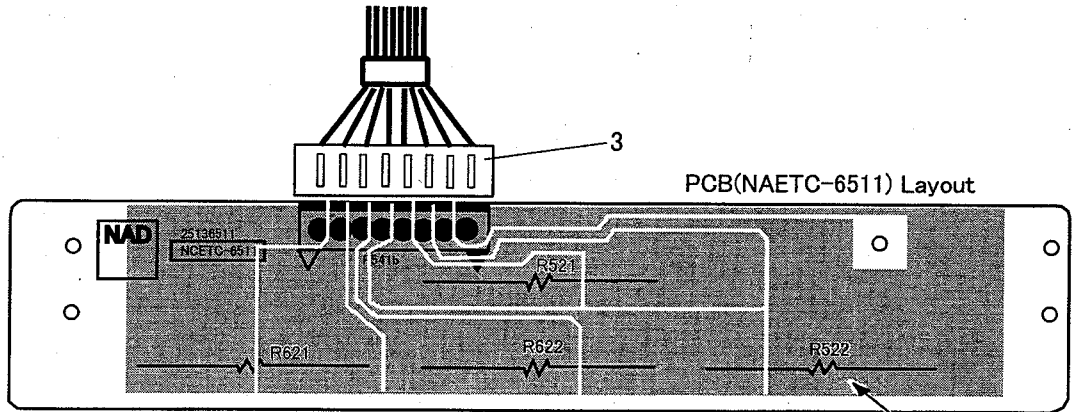

## Parts List

No.	Circuit No.	Part No.	Q'ty	Description
1	R521,R522, R621,R622	4400043	4	1k ohm 5W Metal Oxide
2	P541b	25055138	1	Plug
3	P541	2009990526	1	Socket Ass'y
4		838130088	4	Screw 3TTB +8B
5		27141731	1	Retainer
6		79202	8	Tube L=15mm, 2.5 Φ
7		25136511	1	PC Board