

C 541

**COMPACT
DISC PLAYER**

C 541

**COMPACT
DISC PLAYER**

SERVICE MANUAL

NAD

SAFETY INFORMATION

CAUTION

CAUTION - INVISIBLE LASER RADIATION WHEN OPEN AND INTERLOCKS DEFEATED. AVOID EXPOSURE TO BEAM.

ADVARSEL - USYNLIG LASERSTRÅLING NÅR DEKSEL ÅPNES OG SIKKERHEDSLÅS BRYTES. UNNGÅ EKSPONERING FOR STRÅLEN.

ADVARSEL - USYNLIG LASERSTRÅLING VED ÅBNING. NÅR SIKKERHEDSAFBRYDERE ER UDE AF FUNKTION. UNDGÅ UDSÆTTELSE FOR STRÅLING.

VARNING - OSYNLIG LASERSTRÅLING NÅR DENNA DEL ÄR ÖPPNAD OCH SPÄRRAR ÄR URKOPPLADE. STRÅLEN ÄR FARLIG.

VARO! - AVATTAESSA JA SUOJALUKITUS OHITETTAESSA OLET ALITTIINA NÄKTMÄTÖNTÄ LASERSÄTEILYLLE. ÄLÄ KAISO SÄTEESEEN.

VORSICHT! - UNSICHTBARE LASERSTRAHLUNG TRITT AUS, WENN DECKEL GEÖFFNET UND WENN SICHERHEITVERRIEGELUNG ÜBERBRÜCKT IST. NICHT DEM STRAHL AUSSETZEN.

**CLASS 1
LASER PRODUCT**

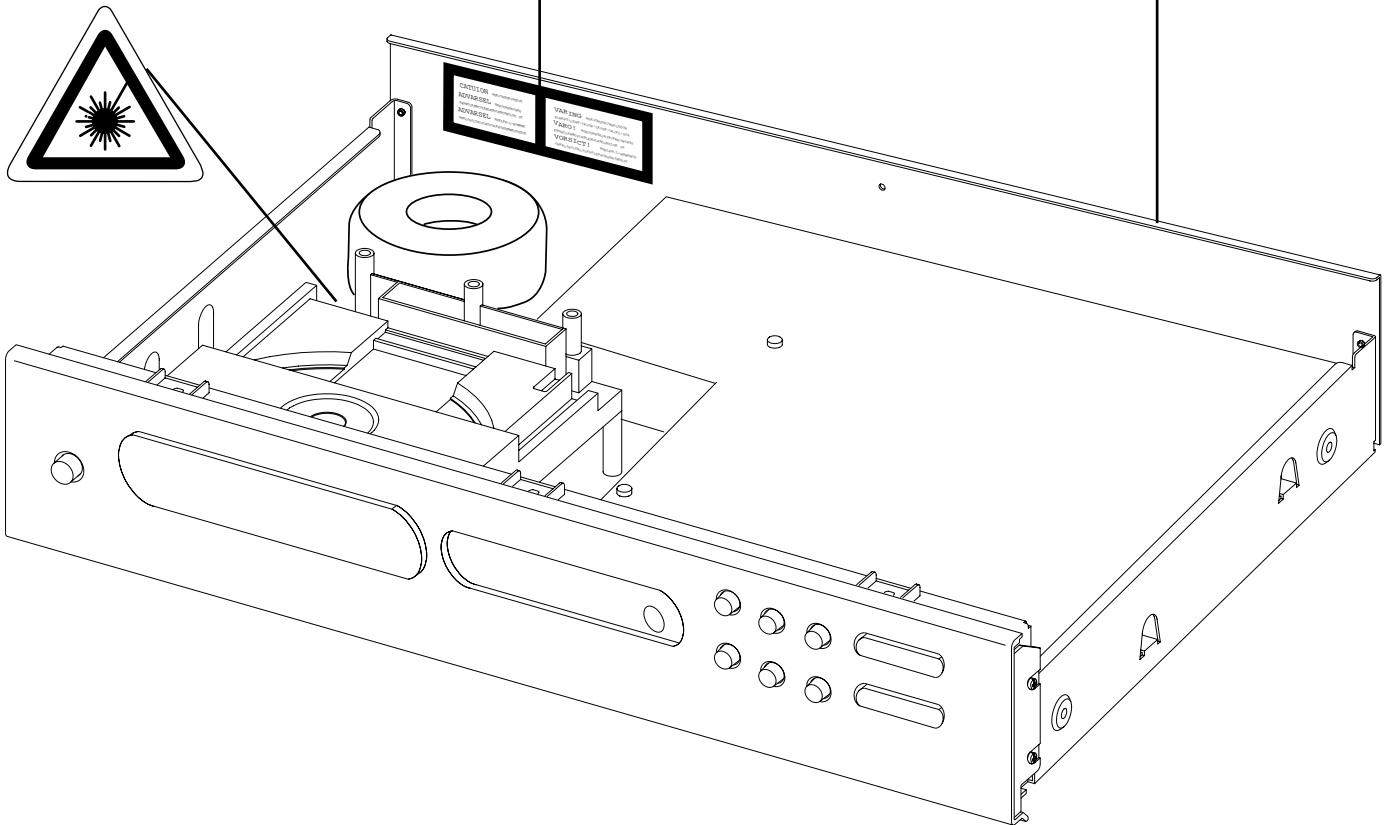

The lightning flash with arrowhead, within an equilateral triangle is intended to alert the user of the presence of uninsulated "dangerous voltage" within the product's enclosure; that may be of sufficient magnitude to constitute a risk of electric shock to persons.









The exclamation point within an equilateral triangle is intended to alert the user of the presence of important operating and maintenance (servicing) instructions in the literature accompanying the appliance.

THIS DEVICE COMPLIES WITH PART 15 OF THE FCC RULES. OPERATION IS SUBJECT TO THE FOLLOWING TWO CONDITIONS:-
(1) THIS DEVICE MAY NOT CAUSE HARMFUL INTERFERENCE, AND
(2) THIS DEVICE MUST ACCEPT ANY INTERFERENCE RECEIVED, INCLUDING INTERFERENCE THAT MAY CAUSE UNDESIRE OPERATION.

SERVICE SAFETY PRECAUTIONS

1. Replacing the fuses

CAUTION: FOR CONTINUED PROTECTION AGAINST THE RISK OF FIRE REPLACE ONLY WITH SAME TYPE OF FUSE.

Reference No	Part Number	Description
M507 *AH 	5120-0052-0	FUSE T1.6A 250V 5X20MM
M512, M513 *AH 	5120-0020-0	FU T1A 250V UL/CSA 5X20
M514 *AH 	5120-0026-0	FU T315MA L 250V UL/CSA
M507 *C 	5120-0050-0	FUSE T1.6A 250V 5X20MM
M512, M513 *C 	5120-0018-0	FU T1A 250V SEMKO/VDE
M514 *C 	5120-0027-0	FU T315MAL 250V

NOTE:

<*AH > : USA, CANADIAN MODEL ONLY.

<*C > : EUROPEAN MODEL ONLY.

2. Safety check out

(Only U.S.A. model)

Before returning the product to the customer, make leakage current or resistance measurements to determine that exposed parts are acceptably insulated from the supply circuit.

Parts marked with the symbol  are critical with regard to the risk of fire and electric shock. Replace only with parts recommended by the manufacturer.

CONTENTS

DESCRIPTION	PAGE
SPECIFICATIONS4
REAR PANEL / FRONT PANEL5
DISASSEMBLY INSTRUCTIONS6
BLOCK DIAGRAM7
WIRING DIAGRAM8
RF PATTERN TESTING9
IMPORTANT NOTES10-11
PCB LAYOUT12-14
SCHEMATIC DIAGRAM15-16
IC BLOCK DIAGRAM17-19
TROUBLESHOOTING GUIDE20
ELECTRICAL PARTS LIST21-26
MECHANISM EXPLODED VIEW27
MECHANISM EXPLODED VIEW PARTS LIST28
EXPLODED VIEW OF LASER CD11CA-G29
EXPLODED VIEW PARTS LIST OF LASER CD11CA-G30
EXPLODED VIEW31
EXPLODED VIEW PARTS LIST32
PACKING DIAGRAM33

SPECIFICATIONS

Disc Capacity	One Disc, 120 or 80 mm
Decoding	BURR-BROWN Delta Sigma 24bit
Digital Filter	8 Times oversample
Analog Filter	4 pole active
Frequency Response	+/- 0.5 dB, 5Hz - 20kHz
De-Emphasis Error	+/- 0.3 dB
THD (at 0 dB, 1kHz)	0.007%
Intermodulation Distortion (19 + 20 kHz)	< - 100 dB
Dynamic Range	96 dB
Linearity	+/- 0.5 dB, 0 dB to -80 dB
Signal / Noise Ratio (A-Weight)	≥102 dB, De-Emphasis on ≥102 dB, De-Emphasis off
Channel Separation 1kHz	>90 dB
10 kHz	>80 dB
Wow and Flutter	Unmeasurable (Quartz Crystal Accuracy)
Output Impedance	200 Ω
Output Level at 0 dB	2.2 V rms
Digital Error Correction	CIRC with double error correction in C1 and C2
Digital Code Output	Sony / Philips Serial data format

CONTROLS

Play / Pause, Stop, Random, Skip (< >), Scan (< >), Open, Time, Repeat.

PHYSICAL SPECIFICATIONS

Dimensions (Width x Height x Depth)	435 x 80 x 285 mm
Net weight	4 kg (8.8 lbs)
Shipping weight	5.1 kg (11.22 lbs)

REAR PANEL / FRONT PANEL

REAR PANEL

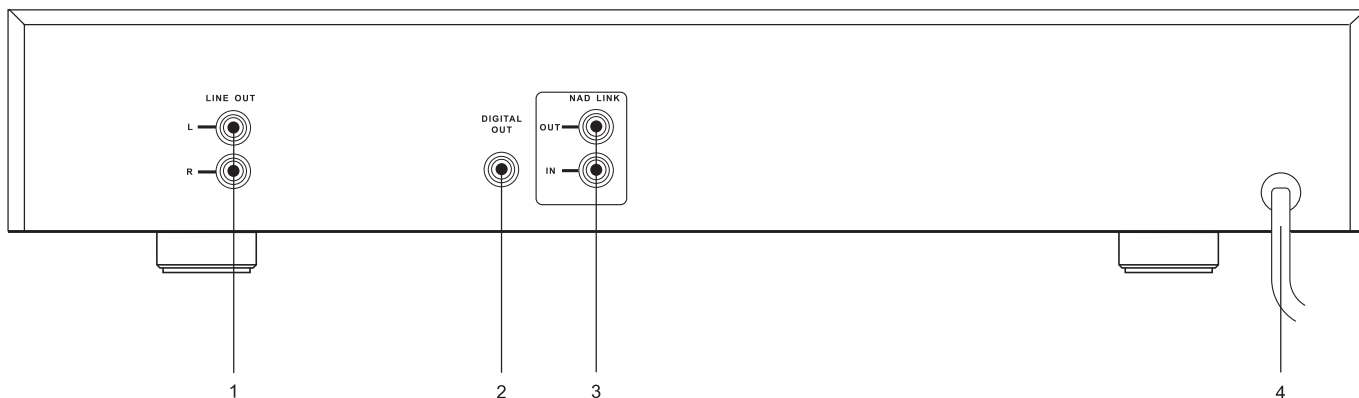

- 1. LINE OUT
- 2. DIGITAL OUT

- 3. NAD LINK
- 4. AC LINE CORD

FRONT PANEL

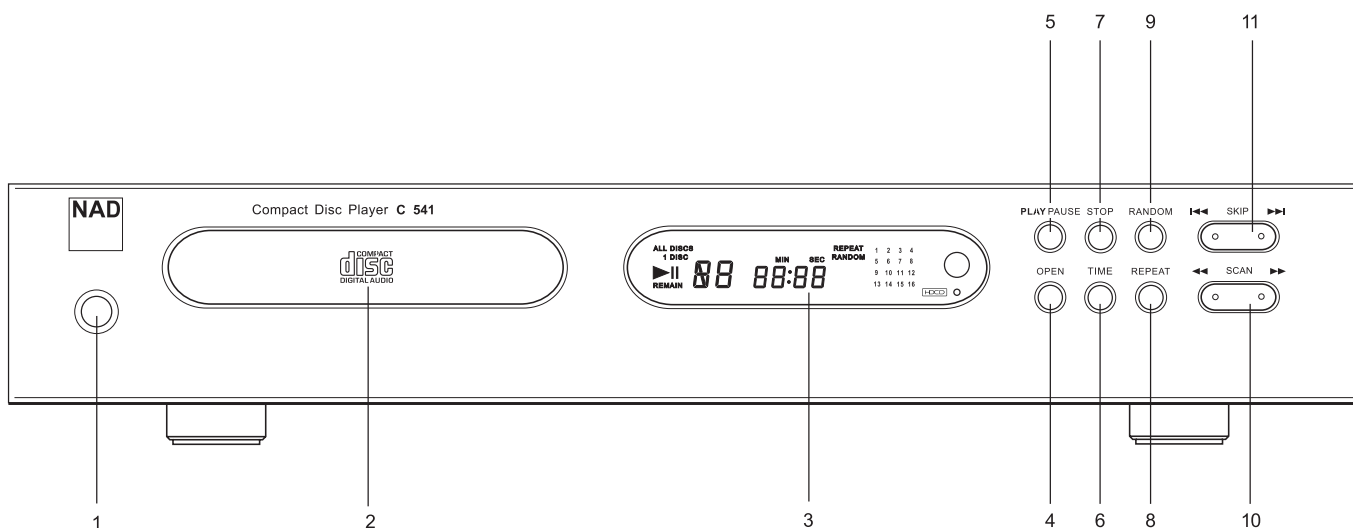

- 1. POWER ON / OFF
- 2. DISC DRAWER
- 3. DISPLAY
- 4. OPEN
- 5. PLAY / PAUSE
- 6. TIME

- 7. STOP
- 8. REPEAT
- 9. RANDOM
- 10. SCAN Back (◀◀) / Forward (▶▶)
- 11. SKIP Back (◀◀◀) / Forward (▶▶▶)

DISASSEMBLY INSTRUCTIONS

1. Remove machine screws M 4.0 x 6.0 (① to ④) from the side panels.
Remove tapping screw 3.0 x 8.5 ⑤ from the back panel.
Refer to **Figure No.1**.

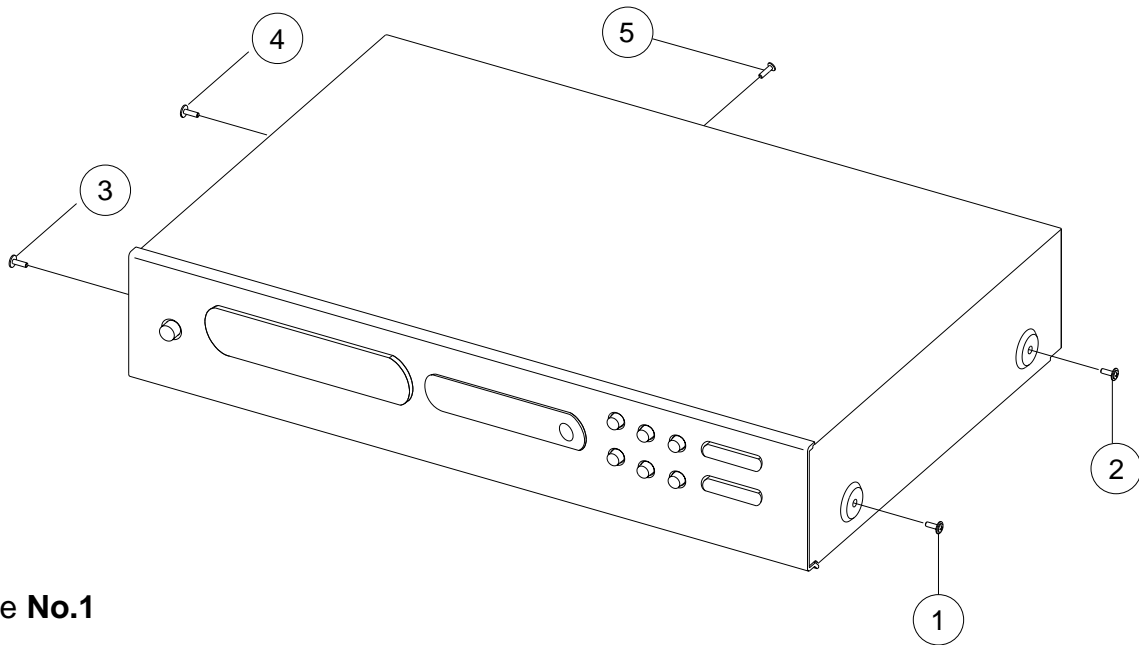

Figure No.1

2. Pull both sides of the TOP COVER slightly outwards ⑥ and tilt approx. 35° and then remove in the direction as indicated by the arrow ⑦ . Refer to **Figure No.2**.

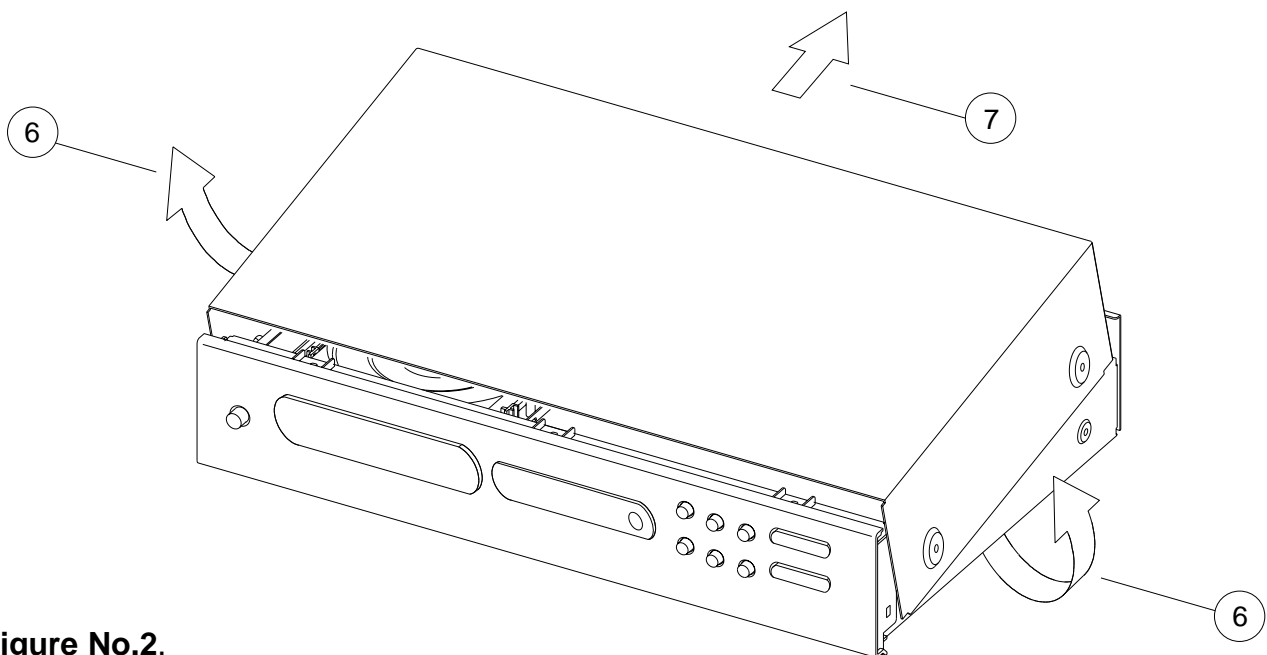
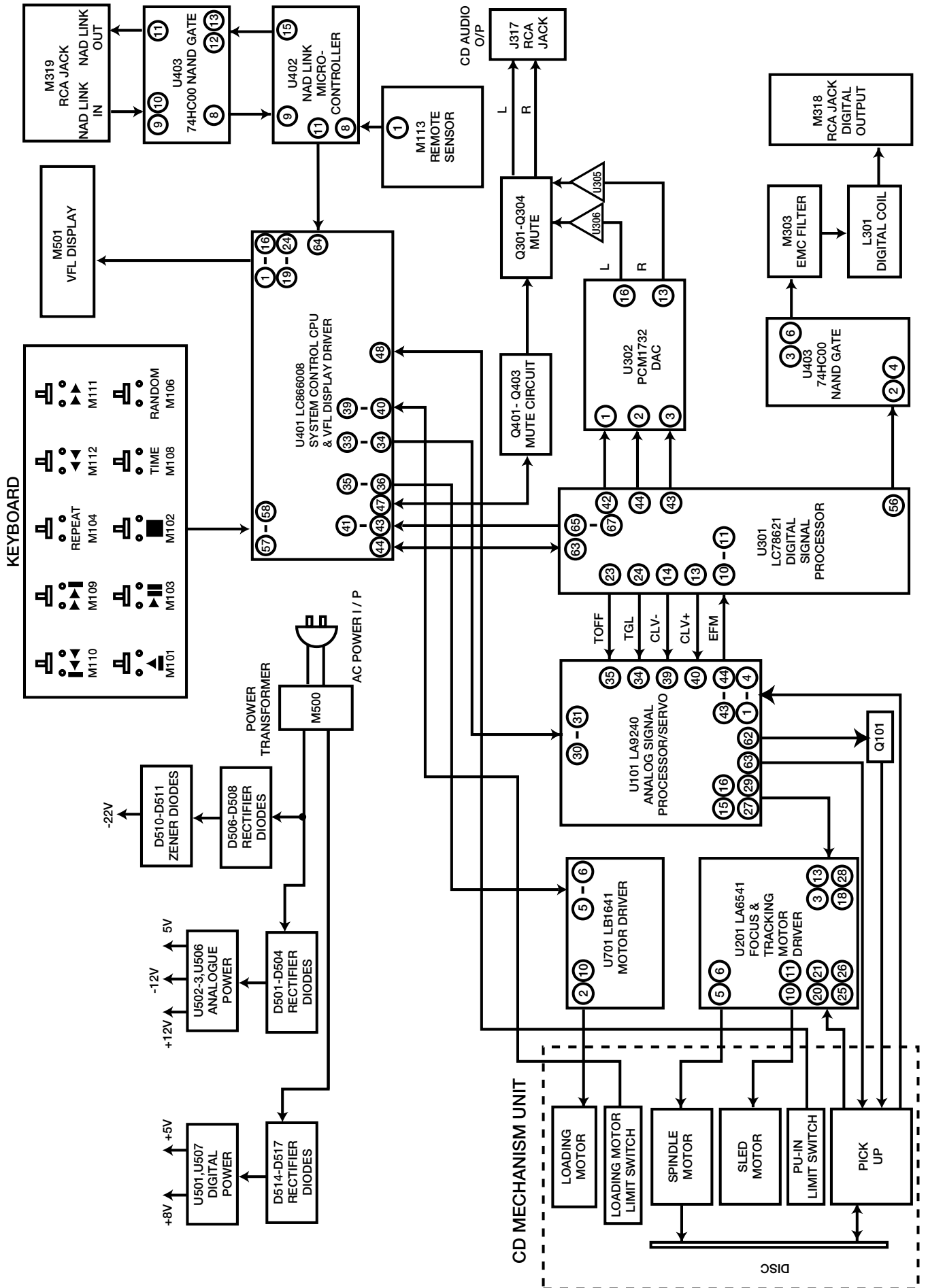
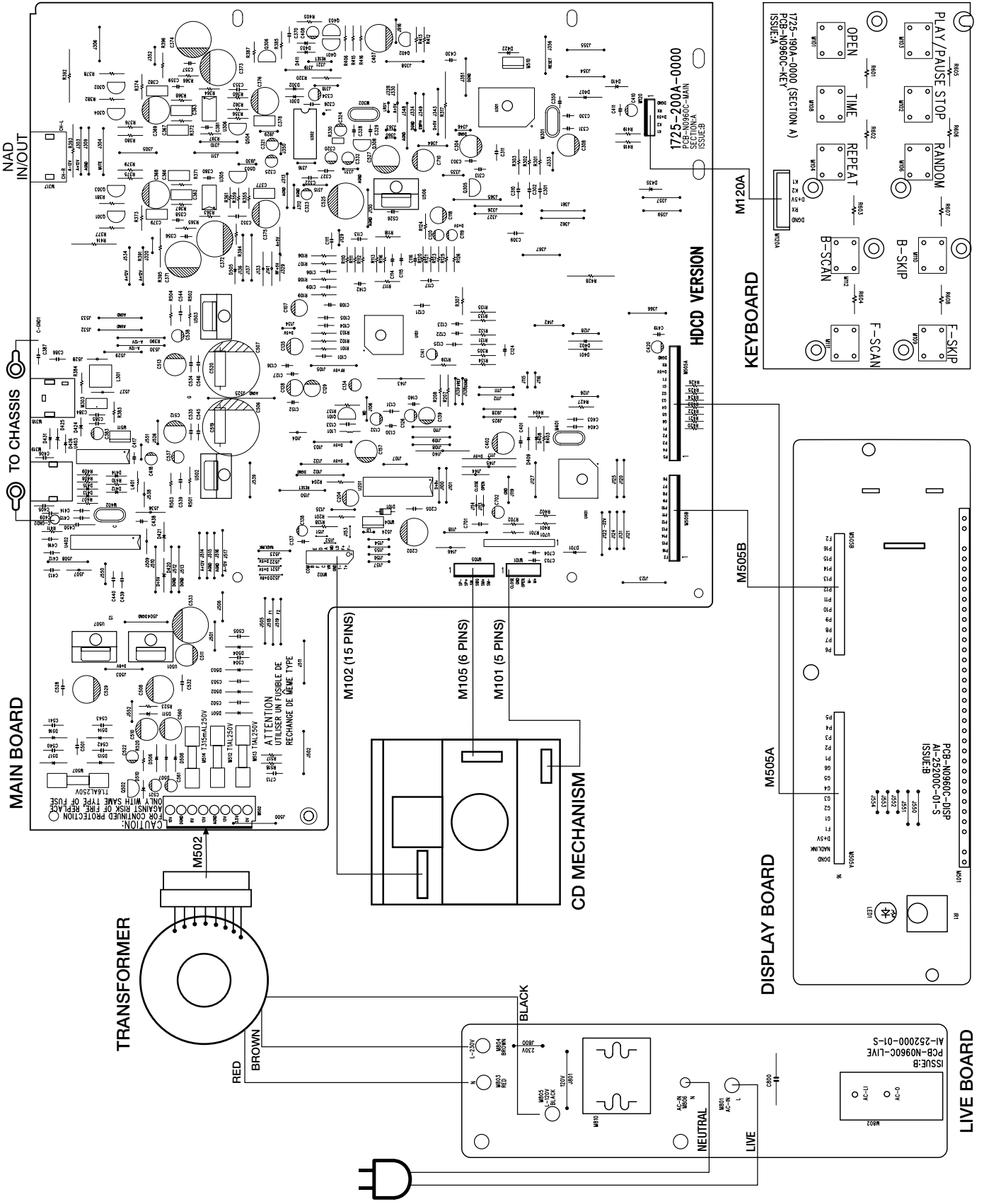

Figure No.2.

BLOCK DIAGRAM



WIRING DIAGRAM



RF PATTERN TESTING

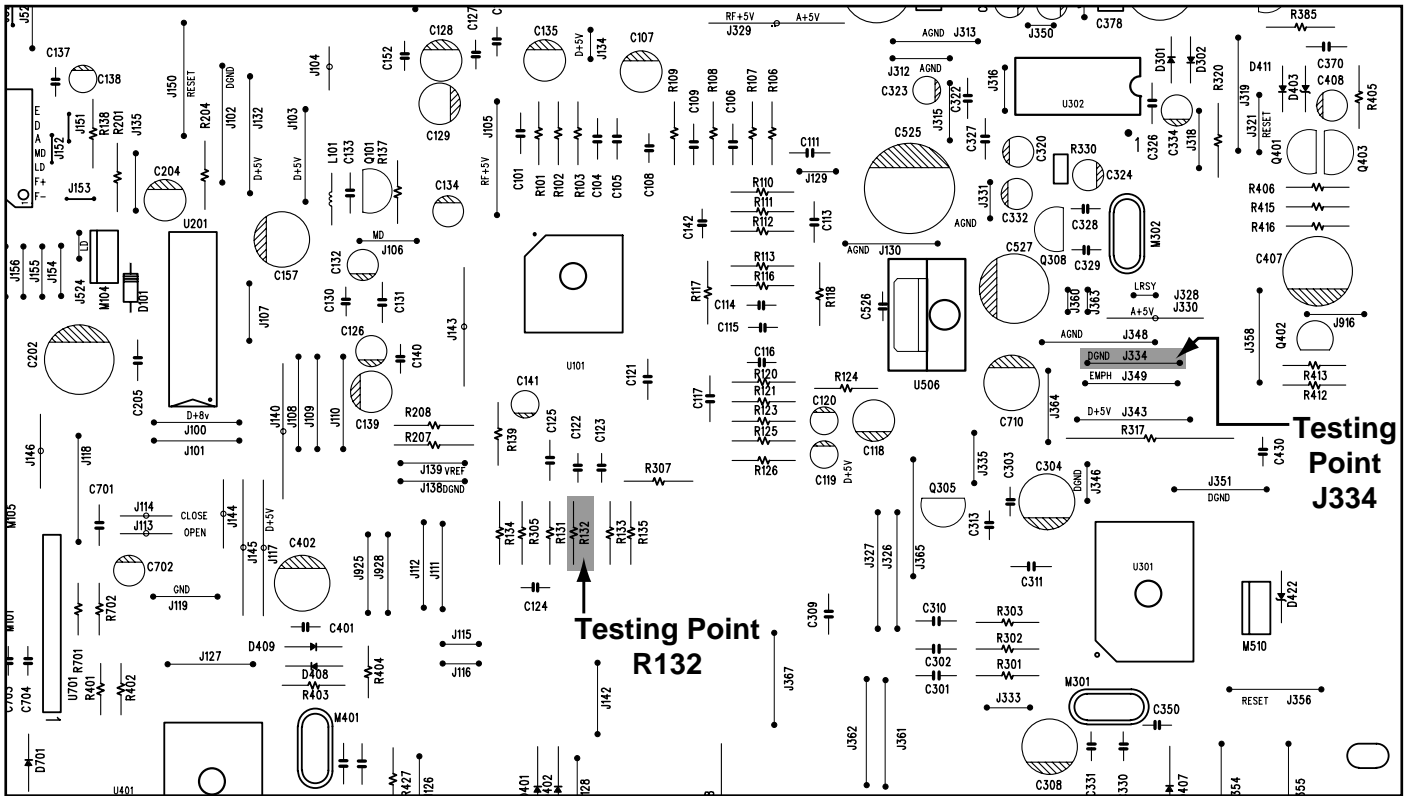

NAD - C 541 PCB TESTING POINTS DIAGRAM

TESTING PROCEDURE

- (1) Load the test disc (Sony Test CD YEDS-7) and set the unit into PLAY mode.
- (2) Connect the scope to R132 (Pin 41 of U101) and DGND (J334).
 Scope setting: Coupling : AC.
 Vertical sensitivity : 0.2 V/ div.
 Horizontal time base : 0.5 μ S/div.
- (3) Observe the waveform is 2.0V p-p +/-5% and the eye pattern is at its best shape (see **FIG. 1**).

FIG. 1 (a)

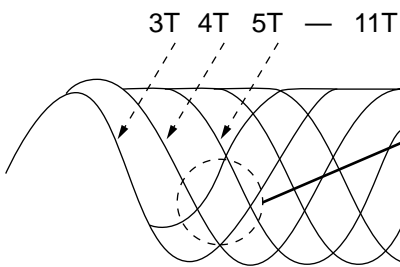

FIG. 1 (b) Poor eye pattern

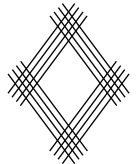
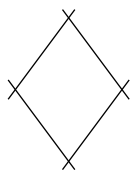

FIG. 1 (C) Good eye pattern



IMPORTANT NOTES

INSTRUCTION FOR HANDLING OPTICAL SYSTEM BLOCK PICK-UP

Electrostatic breakdown of the laser diode in the optical system block may occur due to a potential difference caused by electrostatic charge accumulated on clothing, human body, etc. A ground must be provided as follows to prevent any electrostatic charge during unpacking or repair work.

1. Ground for Human Body

Be sure to wear a ground band (1M ohm) that is properly to remove any static electricity that may be charged on the body.

2. Ground for Work Bench

Be sure to place a conductive sheet (1M ohm) or copper plate with proper grounding on the work bench or other surface on which the pick-up is to be placed.

3. Because the static electricity charge on the clothing does not discharge through the body grounding band, do not let clothing get in contact with the pick-up unit.

INCORRECT



CORRECT

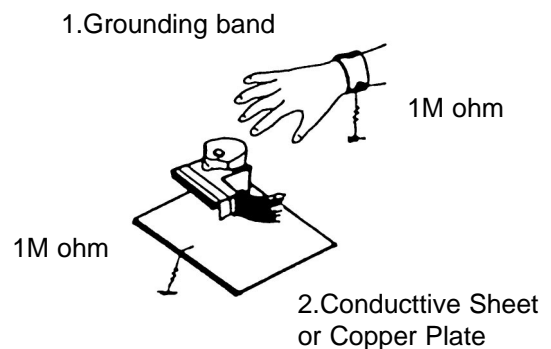

NOTE: Laser diodes are so susceptible to damage from static electricity that even if a static discharge does not ruin the diode, it can shorten its life or cause it to work improperly.

PRECAUTIONS FOR CHECKING BEAM EMISSION

The laser beam of this unit is focused on the reflecting surface of the objective lens in the optical system block. Therefore, keep your eyes at least 12 inches (30 cm) away from the objective lens when the laser diode is **ON**.

(Operation Check Method for Laser Diode and Focus Search Function.)

When the **POWER** switch is turned **ON** after the chucking plate is removed, observe the objective lens and confirm that the following operations are performed properly.

(The optical system should be at the lead-in area position when it is checked at this time.)

(1) The laser should be at the innermost position after the chucking plate is removed.

(2) The diffused light of the laser beam can be seen when the **POWER** switch is turned **ON**.

(3) Vertical (up and down) movement of the objective lens (2 or 3 times) will take place.

PRECAUTIONS WHEN CHANGING LASER PICK-UP

When removing the pick-up assembly, short circuit the PCB tracks on the optical block as show in the drawing in order to protect the pick-up before removal.

NOTE: Replacement pick-up assemblies are supplied with the PCB pattern already protected.

DO NOT REMOVE THE SHORT CIRCUITS UNTIL YOU HAVE FINISHED FITTING THE PICK-UP.

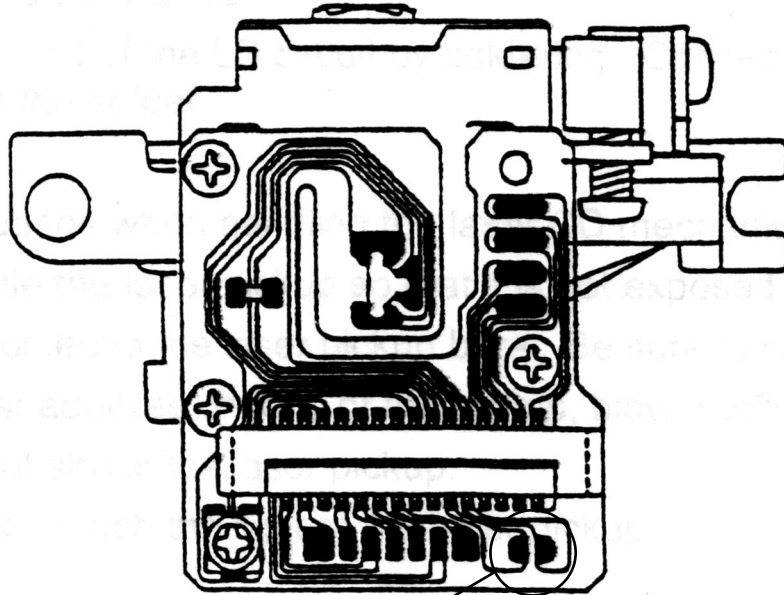

Protective soldering place
for laser diode

Caution:

Laser diodes are extremely susceptible to damage from static electricity. Even if a static discharge does not ruin the diode, it can shorten its life or cause it to work improperly. When replacing the pick-up, use a conductive mat, a grounded soldering iron, and so on, to protect the laser diode from static damage.

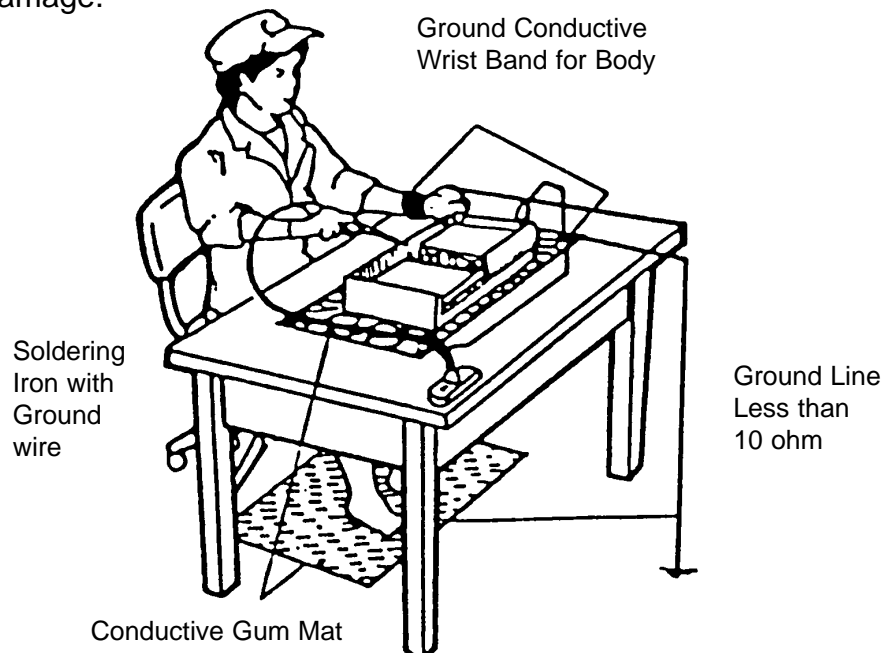

PCB LAYOUT

LIVE BOARD

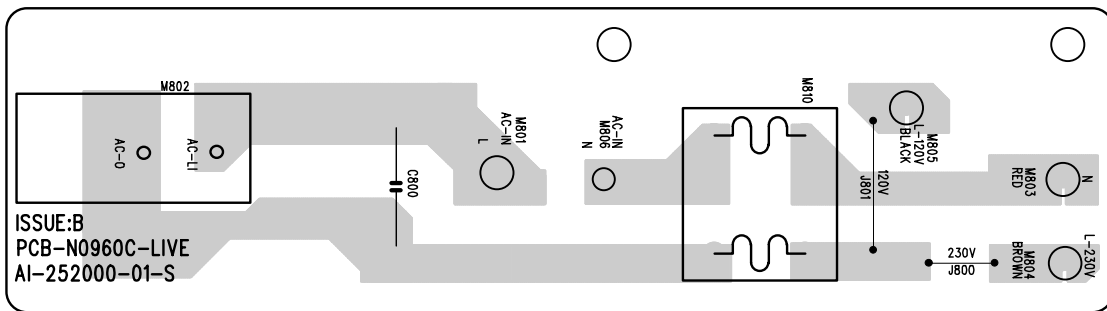

KEY BOARD

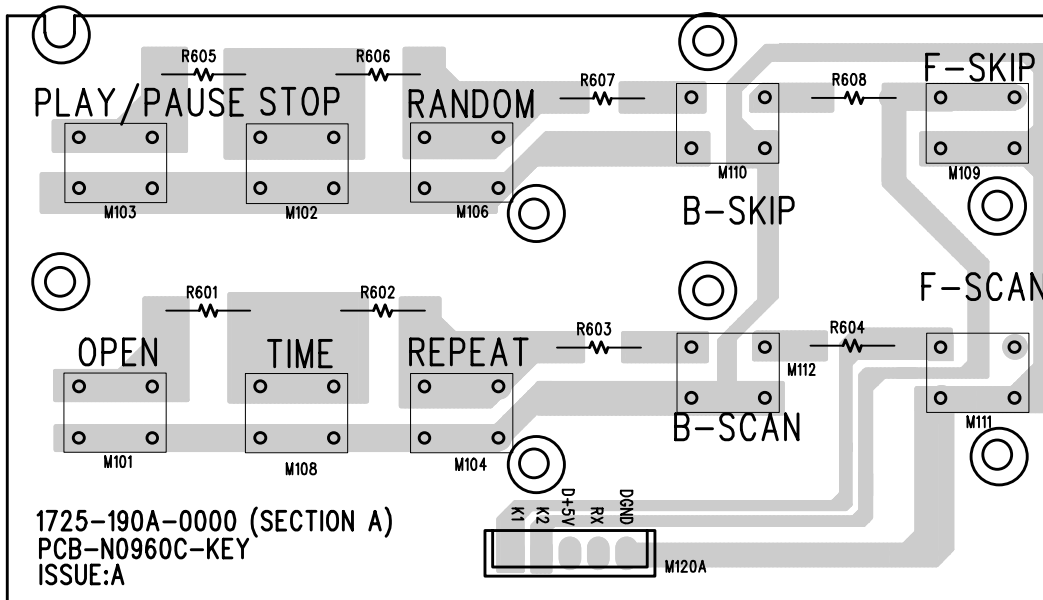

DISPLAY BOARD

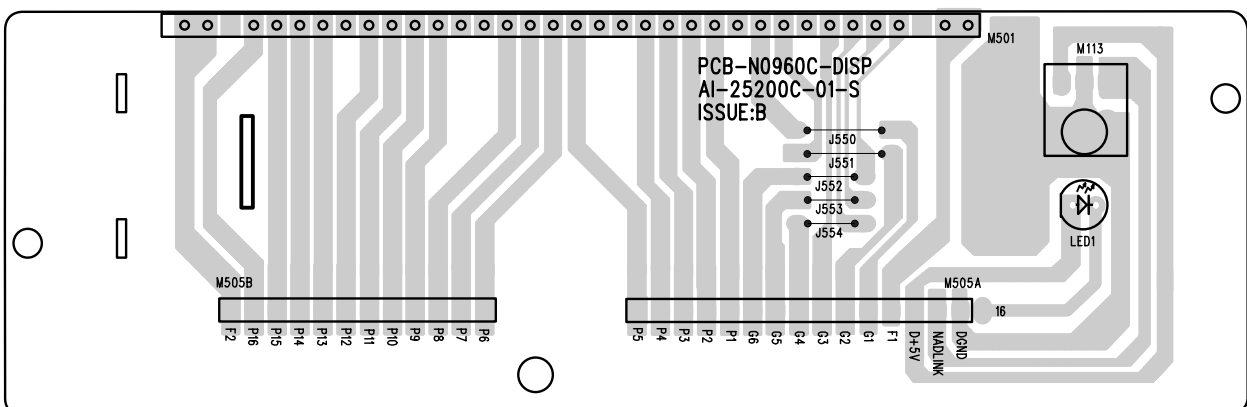

MAIN BOARD

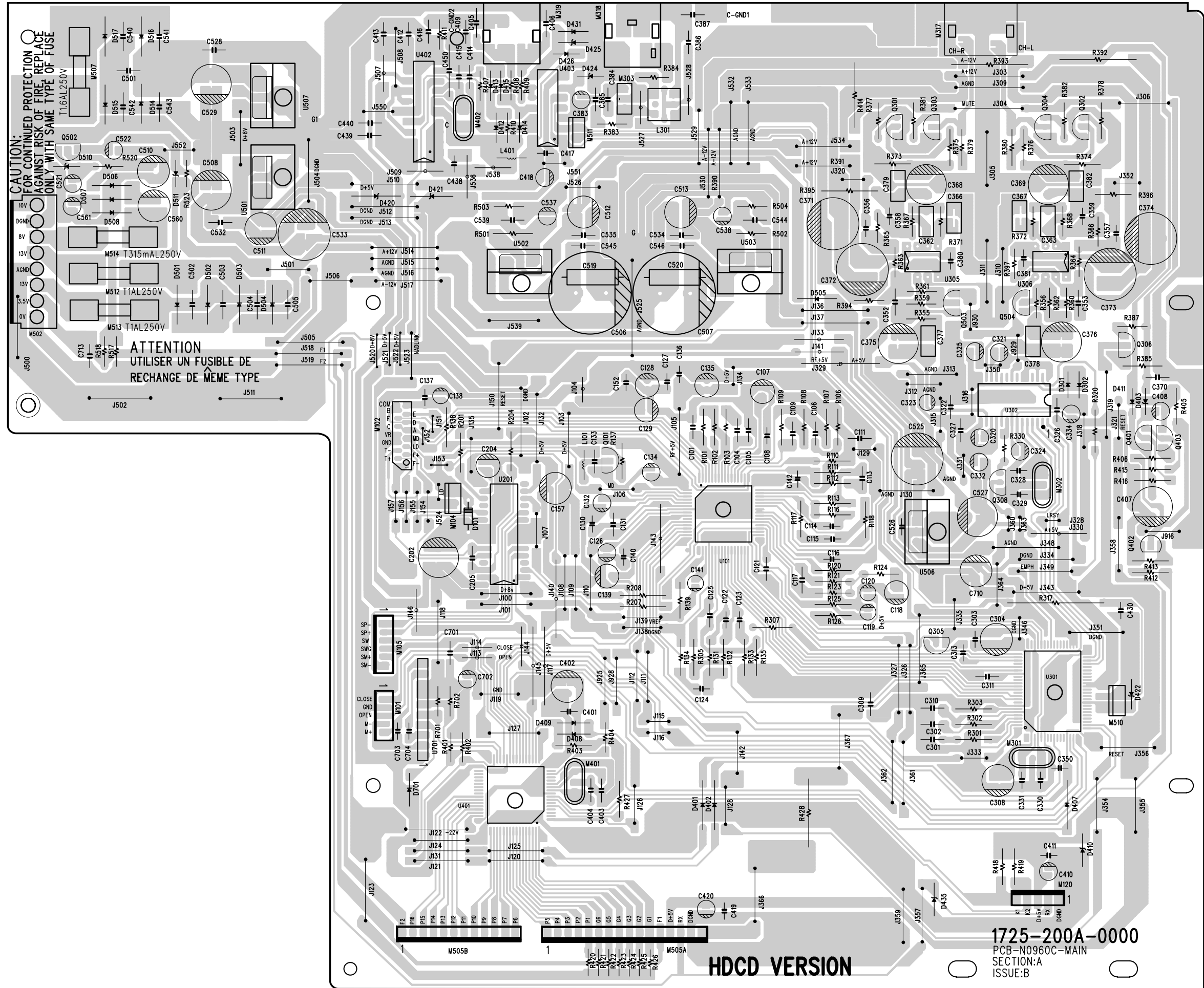

SCHEMATIC DIAGRAM

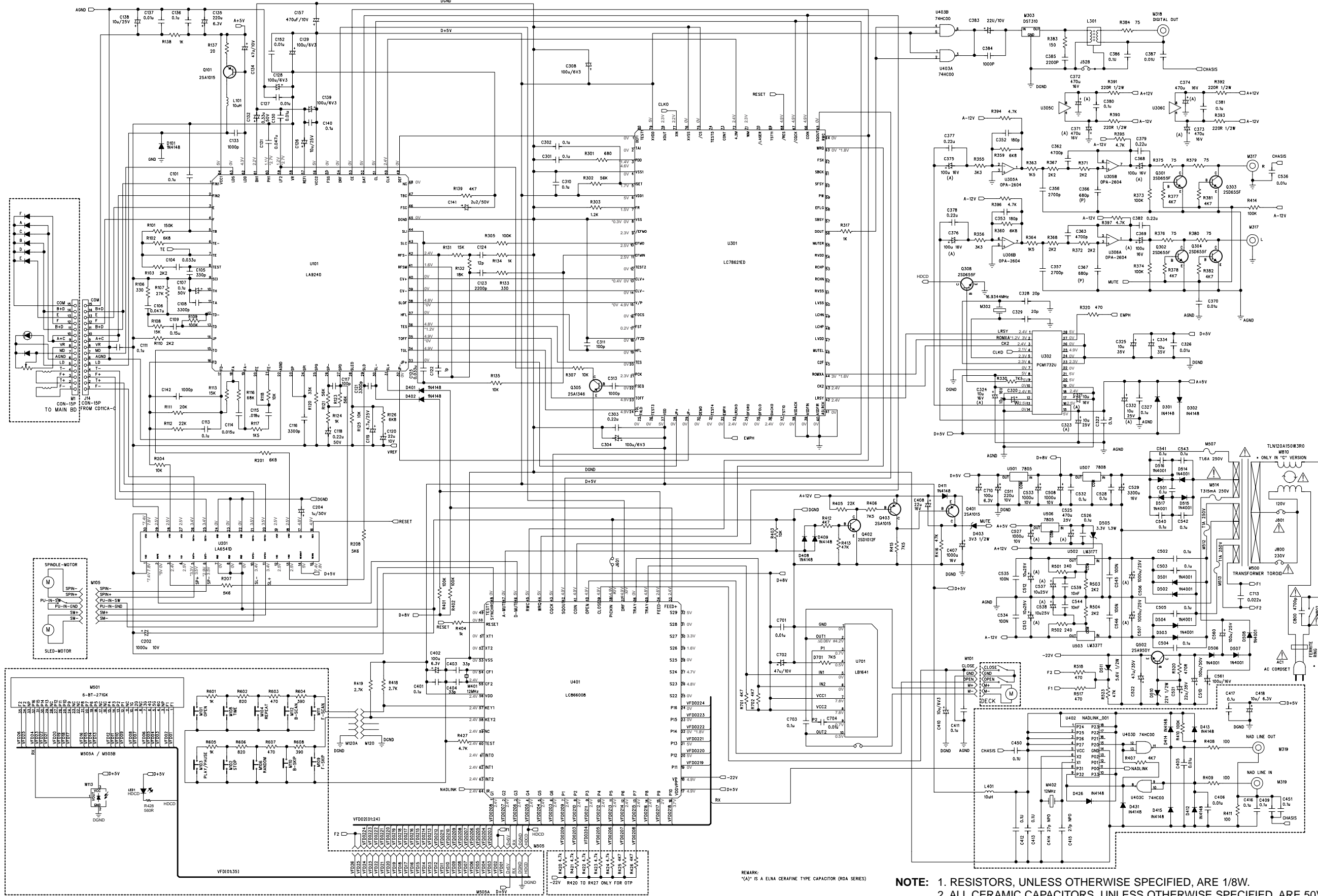

RESISTORS: M- METAL FILM
F- FUSIBLE
CARBON FILM UNLESS OTHERWISE SPECIFIED.

REMARK:
"A" IS A ELNA CERAMIC TYPE CAPACITOR (80A SERIES)

- NOTE:**
1. RESISTORS, UNLESS OTHERWISE SPECIFIED, ARE 1/8W.
 2. ALL CERAMIC CAPACITORS, UNLESS OTHERWISE SPECIFIED, ARE 50V 10%.
 3. COMPONENTS MARKED "▲" ARE SAFETY CRITICAL PARTS.
 4. VOLTAGE SPECIFIED ON THE IC'S PIN WHICH DOES NOT HAS MARKING IS IN STOP MODE, MARKED WITH "+" IS PLAY MODE, "#" IS TRAY OPEN MODE AND "Δ" IS TRAY CLOSE MODE.

IC BLOCK DIAGRAM

U101: LA9240

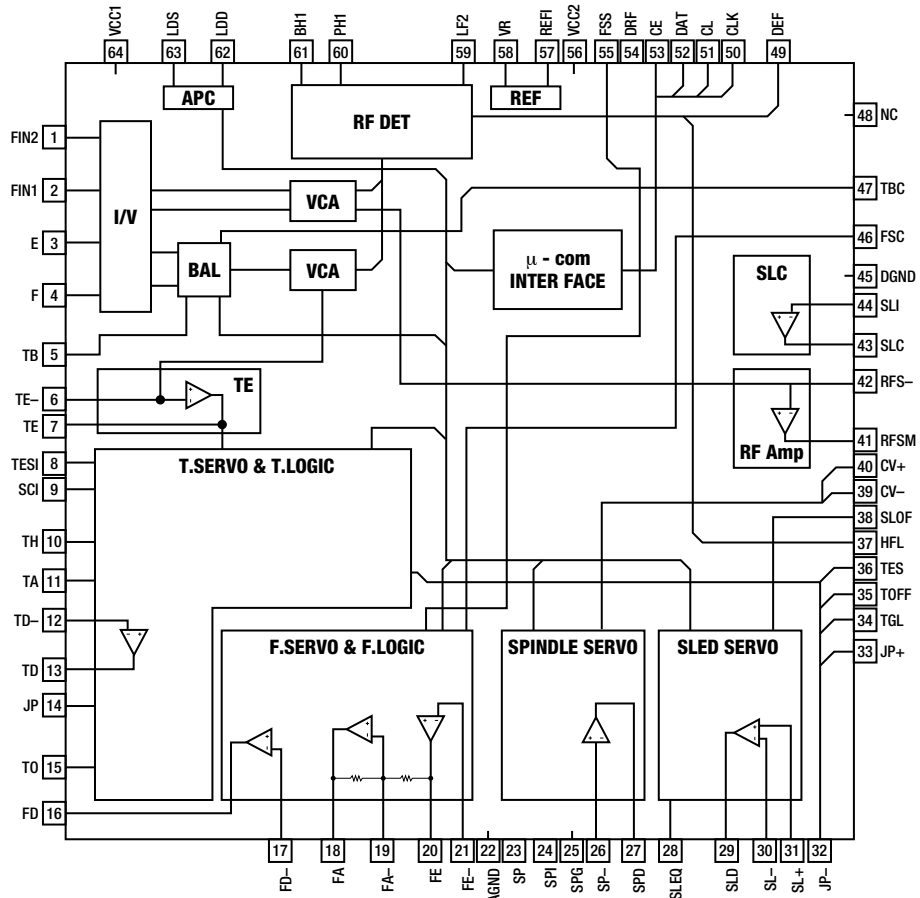

U301: LC78621ED

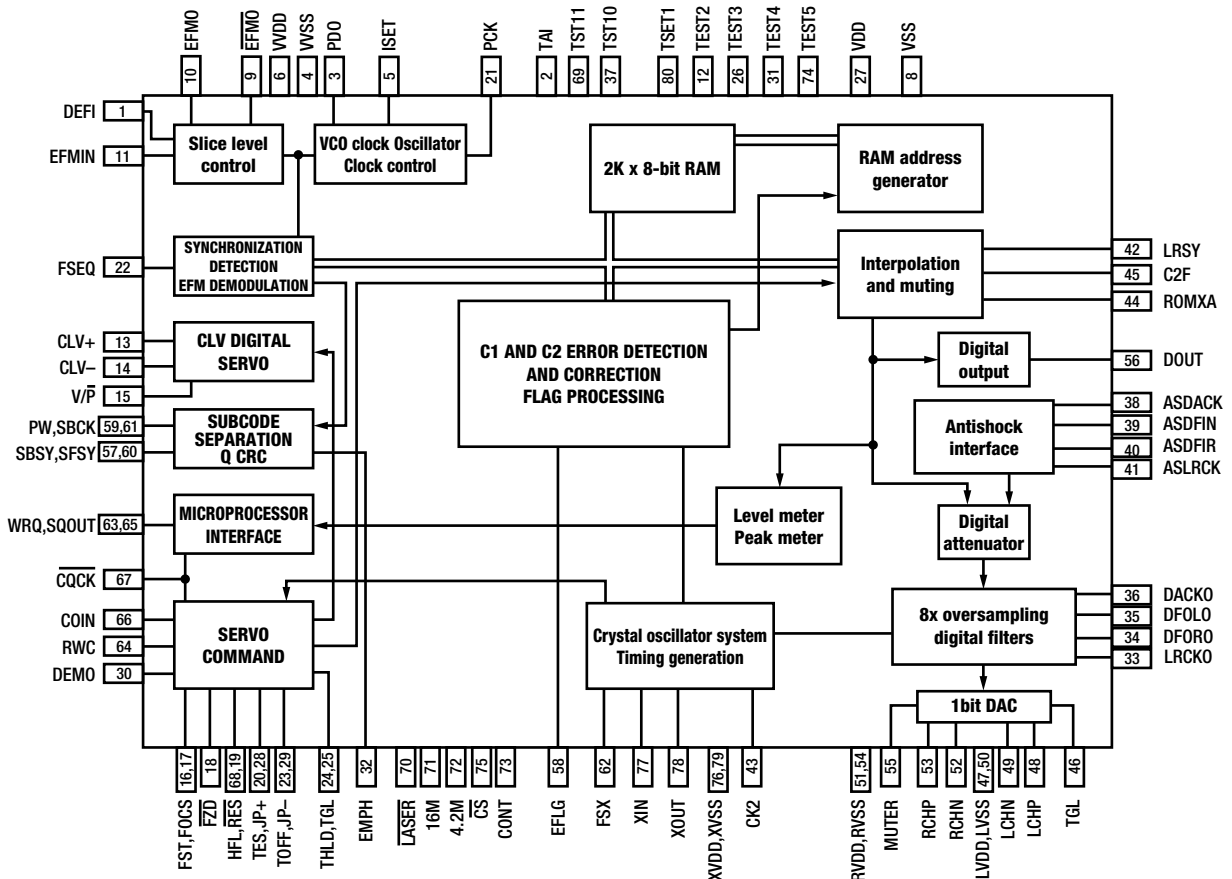

U302: PCM1732

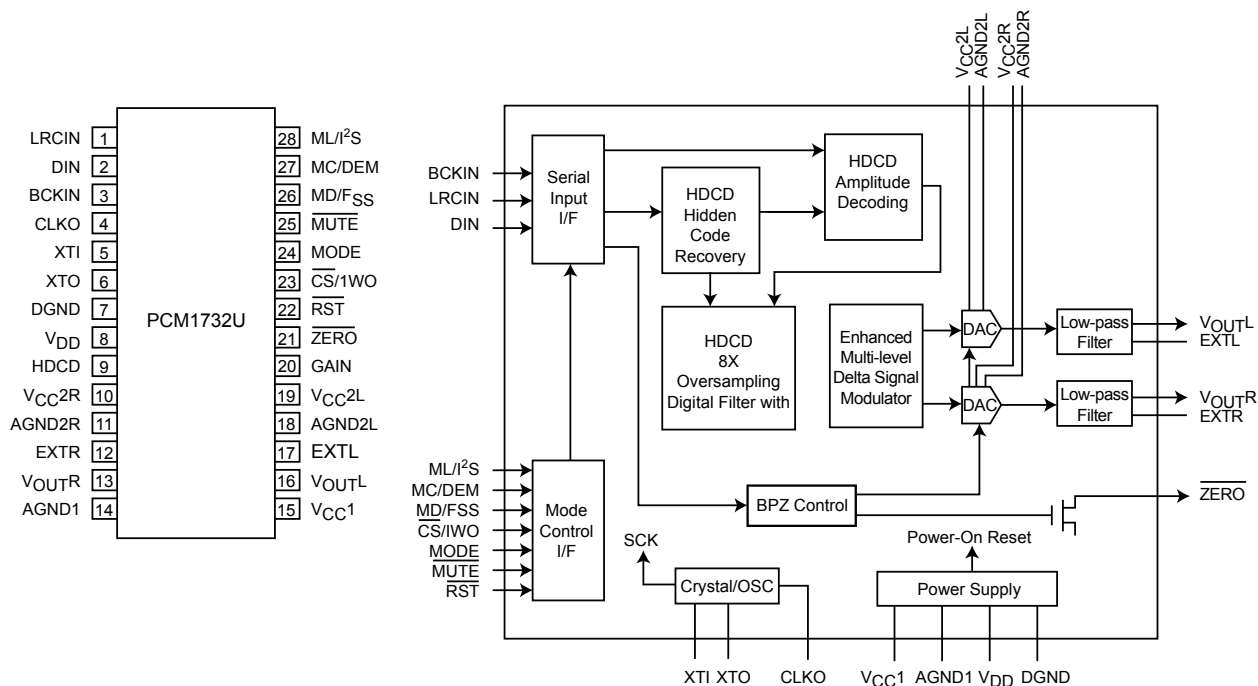

U402: NADLINK(MASKED)

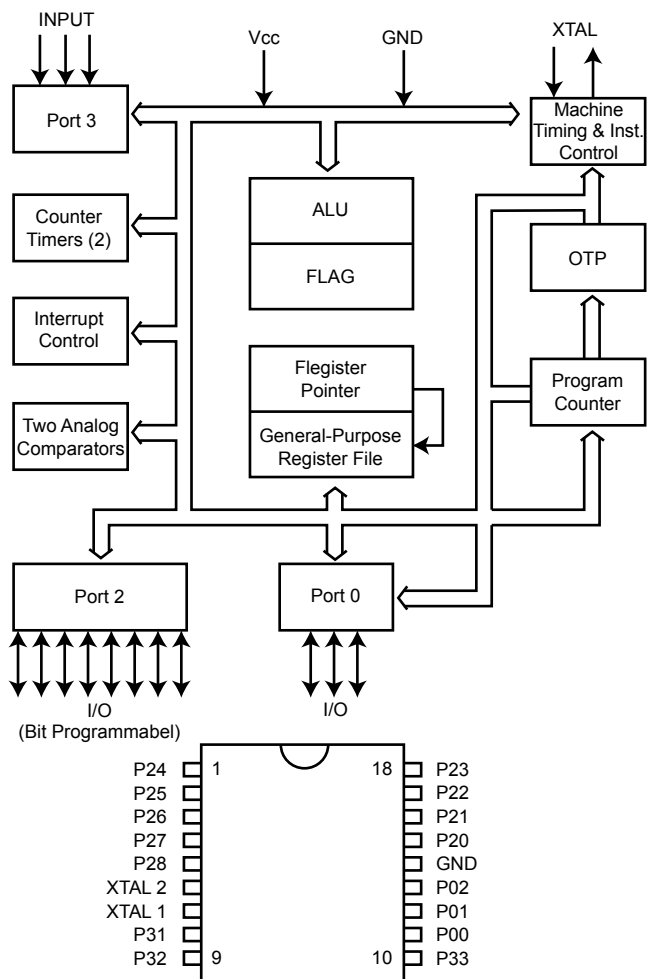

U201: LA6541D

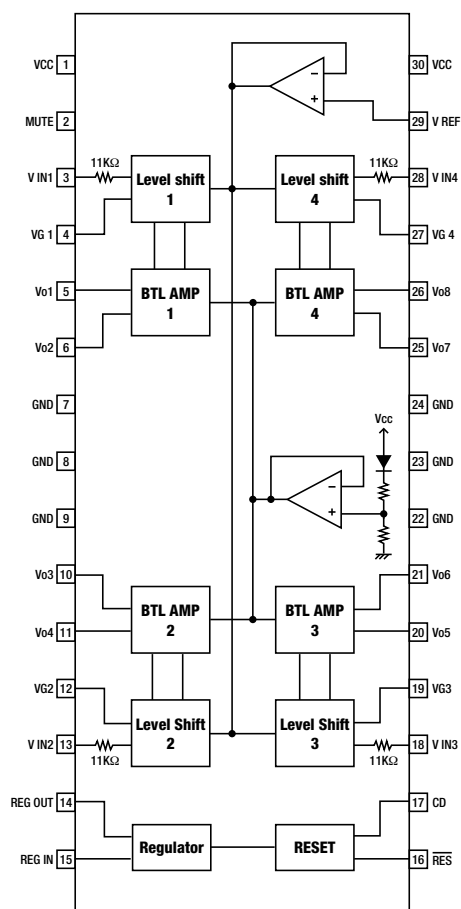

U403: 74HC00

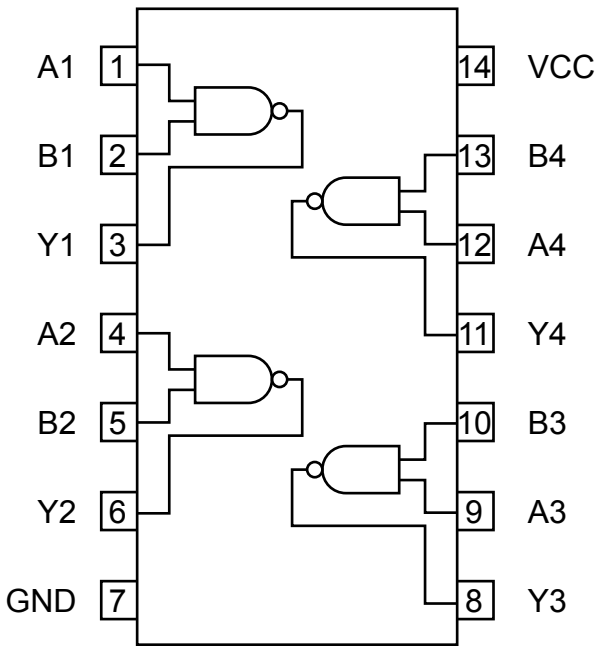

U701: LB1641

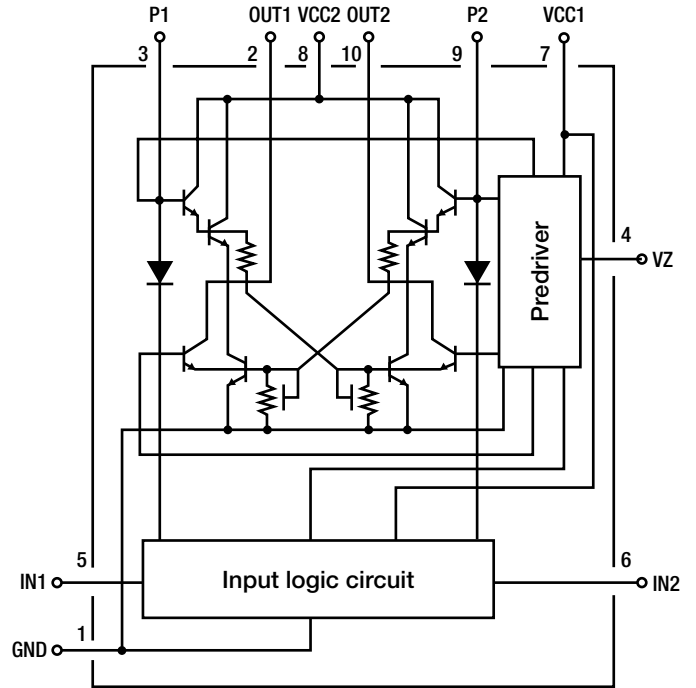

U401: LC866008C

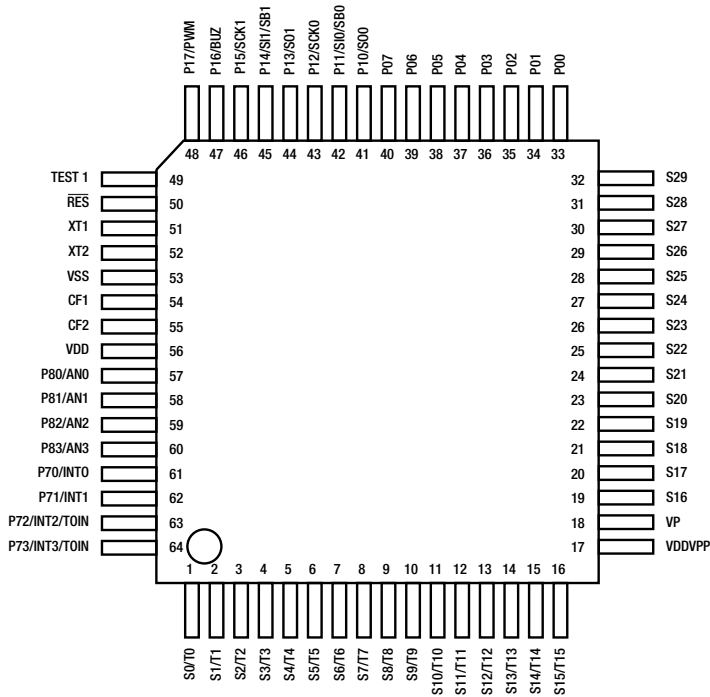

IC401: System Block Diagram LC8660/08C

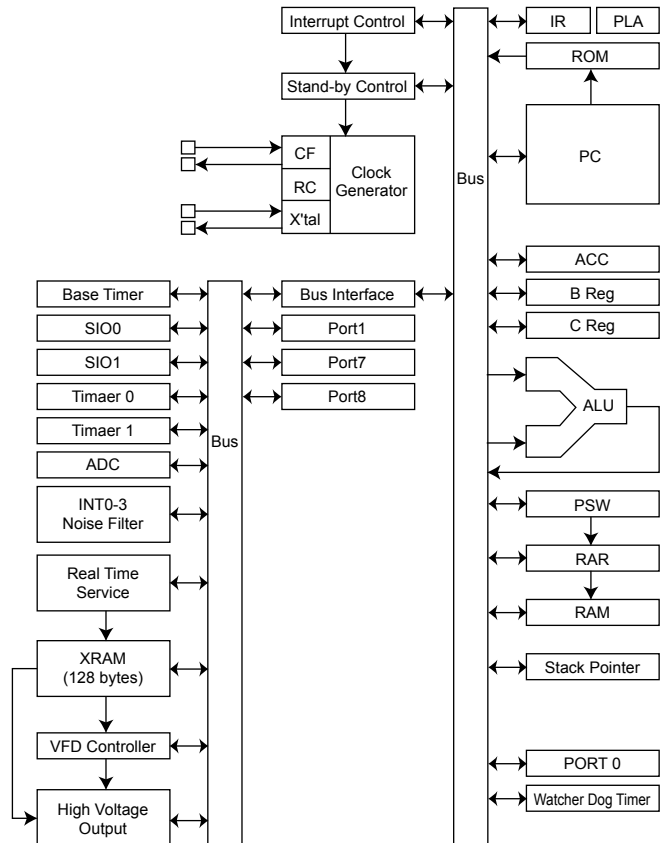



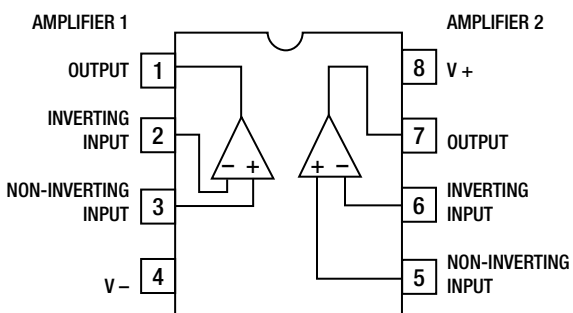

U305-U306: OPA2604

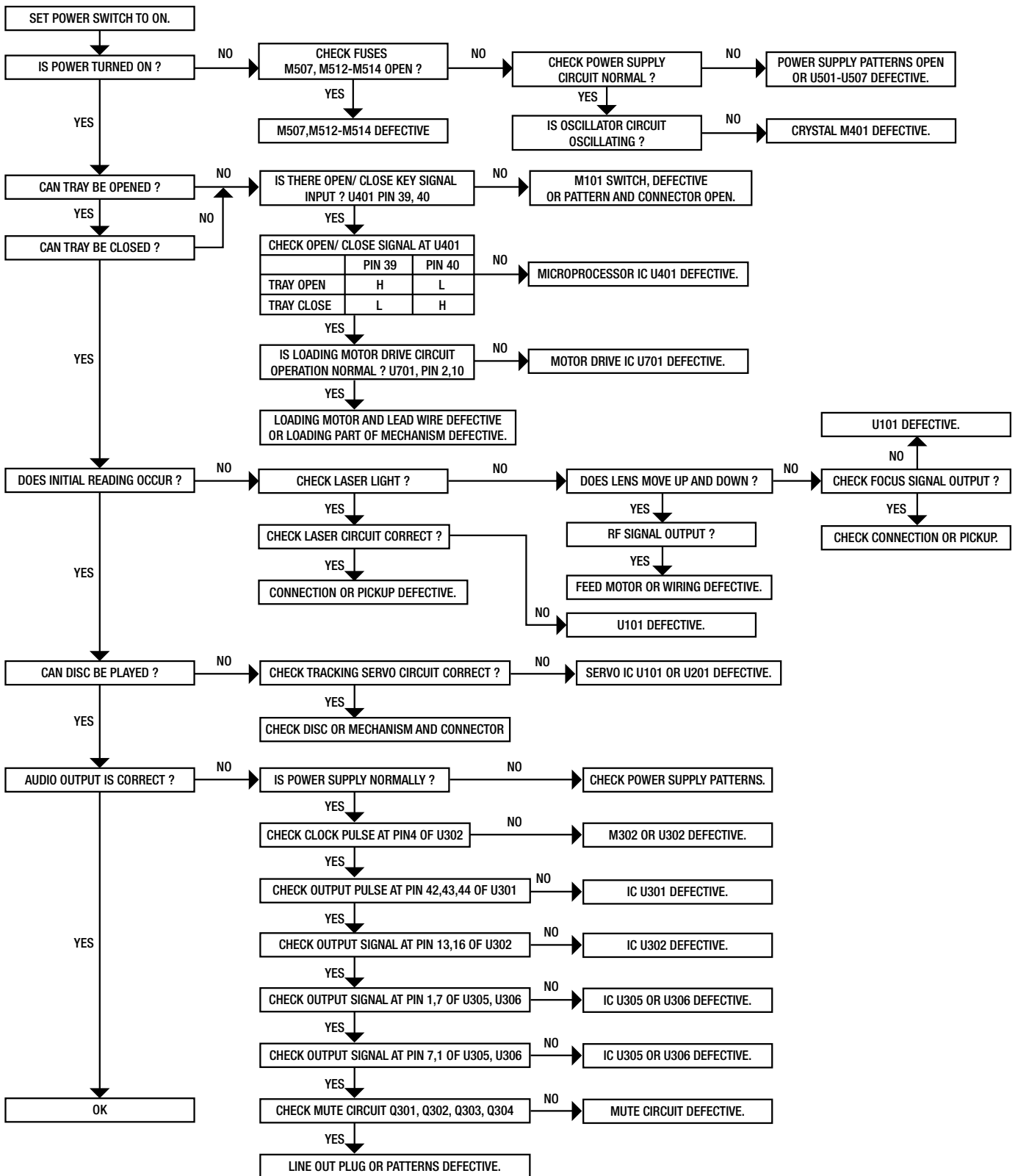

TROUBLESHOOTING GUIDE



ELECTRICAL PARTS LIST

<u>Reference No.</u>	<u>Part No.</u>	<u>Description</u>
<u>DISPLAY ASSEMBLY</u> <u>PCB BOARD</u> 1000	PCB-N0960C-DISP	DISPLAY ASSEMBLY
<u>LED</u> LED1	3700-2810-R	LED RED 3MM SP L-93XHD
<u>IR SENSOR</u> M113	4816-043T-3	IR SENSOR PIC-26043TM2 KODENSHI
<u>VFL</u> M501	2460-1870-0	VFD 6-BF-271GK
<u>KEYBOARD ASSEMBLY</u> <u>PC BOARD</u> 2000	PCB-N0960C-KEY	KEYBOARD ASSEMBLY
<u>RESISTORS</u> R601 R602 R603 R604 R605 R606 R607 R608	4701-102J-C 4701-821J-C 4701-471J-C 4701-391J-C 4701-102J-C 4701-821J-C 4701-471J-C 4701-391J-C	RCF 1/8W 1K 5% ATS RCF 1/8W 820R 5% ATS RCF 1/8W 470R 5% ATS RCF 1/8W 390R 5% ATS RCF 1/8W 1K 5% ATS RCF 1/8W 820R 5% ATS RCF 1/8W 470R 5% ATS RCF 1/8W 390R 5% ATS
<u>SWITCHES</u> M101-M104,M106 M108-M112	5200-3538-0 5200-3538-0	SWITCH, TACT SKHHBY 7MM HIGH SWITCH, TACT SKHHBY 7MM HIGH
<u>LIVE ASSEMBLY</u> <u>PC BOARD</u> 3000 *AH 3000 *C	PCB-N0960C-LIVE PCB-N0961C-LIVE	LIVE ASSEMBLY LIVE ASSEMBLY
<u>CAPACITOR</u> C800 	8910-0049-0	CAP400V 4700P DE7150F472MVA1KC
<u>POWER SWITCH</u> M802 	5200-3151-0-01	POWER SWITCH
<u>TRANSFORMER</u> M810  *C	1806-2170-0	EMI FILTER TLN12UA 150W3R0
<u>TRANSFORMER ASSEMBLY</u>		
<u>TRANSFORMER</u> M500 	1806-2512-0	TRANSFORMER N0870C I/P 120/230V TOROIDAL
<u>FUSE ASSEMBLY</u>		

Reference No.	Part No.	Description
FUSES		
M507 △ *AH	5120-0052-0	FUSE T1.6A 250V 5 x 20MM
M507 △ *C	5120-0050-0	FUSE T1.6A 250V 5 x 20MM
M512, M513 △ *AH	5120-0020-0	FU T1A 250V UL/CSA 5 x 20
M512, M513 △ *C	5120-0018-0	FU T1A 250V SEMKO/VDE
M514 △ *AH	5120-0026-0	FU T315MA L 250V UL/CSA
M514 △ *C	5120-0027-0	FU T315MAL 250V
MAIN ASSEMBLY		
PC BOARD		
4000	PCB-N0960C-MAIN	MAIN ASSEMBLY
CAPACITORS		
C101	150F-104K-2-FC	CC 50V 0.1μF 10% AT
C104	153F-333J-5-MS	CM 50V 0.033μF 5% RL
C105	150F-331K-2-FC	CC 50V 330pF 10% AT 3.5x
C106	153F-473J-5-NR	CM 50V 0.047μF 5% RL
C107	157F-104M-5-GMK	CE 50V 0.1μF 20% RL
C108	153F-332J-5-KW	CM 50V 3300pF 5% RL 6x12
C109	153F-154J-5-NLM	CM 50V 0.15μF 5% RL
C111,C113	150F-104K-5-II	CC 50V 0.1μF 10% RL 5x5
C114	153F-683K-5-OS	CM 50V 0.068μF 10% RL 8x
C115	153F-183J-5-KJ	CM 50V 0.018μF 5% RL
C116	153F-332J-5-KW	CM 50V 3300pF 5% RL 6x12
C117	150F-101K-2-FC	CC 50V 100pF 10% AT 3.5x
C118	157F-224M-5-GMK	CE 50V 0.22μF 20% RL 4X7
C119	157E-475M-5-GMK	CE 25V 4.7μF 20% RL 4x7
C120	157C-226M-5-IUK	CE 10V 22μF 20% RL 5X11
C121	153F-332J-5-KW	CM 50V 3300pF 5% RL 6x12
C122	15CH-050D-5-GG	CTC 0/60 5pF 0.5pF RL
C123	153F-222J-5-IM	CM 50V 2200pF 5% RL 5X7
C124	15CH-120J-5-GG	CTC 0/60 12pF 5% RL 4x4
C125	153F-333J-5-MS	CM 50V 0.033μF 5% RL
C126	157E-106M-5-GMK	CE 25V 10μF 20% RL 4X7
C127	153F-103J-5-IM	CM 50V 0.01μF 5% RL 5X7
C128,C129	157B-107M-5-KMK	CE 6.3V 100μF 20% RL
C130	153F-103J-5-IM	CM 50V 0.01μF 5% RL 5X7
C131	153F-473J-5-NR	CM 50V 0.047μF 5% RL
C132	157F-334M-5-GMK	CE 50V 0.33μF 5% RL
C133	153F-102J-5-IM	CM 50V 1000pF 5% RL 5x7
C134	157C-476M-5-IMK	CE 10V 47μF 20% RL 5X7
C135	157B-227M-5-LMK	CE 6.3V 220μF 20% RL
C136	150F-104K-5-II	CC 50V 0.1μF 10% RL 5x5
C137	153F-103J-5-IM	CM 50V 0.01μF 5% RL 5X7
C138	157E-106M-5-GMK	CE 25V 10μF 20% RL 4X7
C139	157B-107M-5-KMK	CE 6.3V 100μF 20% RL
C140	150F-104K-5-II	CC 50V 0.1μF 10% RL 5x5
C141	157F-225M-5-GMK	CE 50V 2.2μF 20% RL 4x7
C142	153F-102J-5-IM	CM 50V 1000pF 5% RL 5x7
C152	153F-103J-5-IM	CM 50V 0.01μF 5% RL 5X7
C157	157C-477M-5-OVK	CE 10V 470μF 20% RL
C202	157C-108M-5-S5K	CE 10V 1000μF 20% RL
C204	157D-106M-5-GMK	CE 16V 10μF 20% RL 4x7
C205	153F-103J-5-IM	CM 50V 0.01μF 5% RL 5X7
C301,C302	150F-104K-5-II	CC 50V 0.1μF 10% RL 5x5
C303	153F-223J-5-LQ	CM 50V 0.022μF 5% RL
C304,C308	157B-107M-5-KMK	CE 6.3V 100μF 20% RL
C310	150F-104K-5-II	CC 50V 0.1μF 10% RL 5x5
C311	150F-101K-2-FC	CC 50V 100pF 10% AT 3.5x

Reference No.	Part No.	Description
C313	153F-102J-5-IM	CM 50V 1000pF 5% RL 5x7
C320,C321	157D-106M-5-luf3	CE 16V 10µF 20% RL 5X11
C322	150F-104K-5-II	CC 50V 0.1µF 10% RL 5x5
C323,C324	157D-106M-5-luf3	CE 16V 10µF 20% RL 5X11
C325	157Q-106M-5-IUK	CE 35V 10µF 20% RL 5X11
C326,C327	150F-104K-5-II	CC 50V 0.1µF 10% RL 5x5
C328,C329	15CH-200J-5-GG	CTC 0/60 20pF 5% RL 4x4
C332	157D-106M-5-luf3	CE 16V 10µF 20% RL 5X11
C334	157Q-106M-5-IUK	CE 35V 10µF 20% RL 5X11
C350	150F-104K-5-II	CC 50V 0.1µF 10% RL 5x5
C352,C353	150F-181K-2-FC	CC 50V 180pF 10% AT
C356,C357	153F-272J-5-JM	CM 50V 2700pF 5% RL
C362,C363	153I-472K-9-NL	CM 63V 0.0047µF 10% RB
C366,C367	158F-681J-5-KW	CP 50V 680pF 5% RL 6x12
C368,C369	157D-107M-5-SXF3	CE 16V 100µF 20% RL
C370	153F-103J-5-IM	CM 50V 0.01µF 5% RL 5X7
C371-C374	157D-477M-5-X9F3	CE 16V 470µF 20% RL
C375,C376	157D-107M-5-SXF3	CE 16V 100µF 20% RL
C377-C379	153I-224J-9-NL	CM 63V 0.22µF 5% RB 7.5x
C380,C381	150F-104K-5-II	CC 50V 0.1µF 10% RL 5x5
C382	153I-224J-9-NL	CM 63V 0.22µF 5% RB 7.5x
C383	157C-226M-5-IUK	CE 10V 22µF 20% RL 5X11
C384	153F-102J-5-IM	CM 50V 1000pF 5% RL 5x7
C385	153F-222J-5-IM	CM 50V 2200pF 5% RL 5X7
C386	150F-104K-5-II	CC 50V 0.1µF 10% RL 5x5
C387	150F-103K-5-II	CC 50V 0.01µF 10% RL 5x5
C401	150F-104K-5-II	CC 50V 0.1µF 10% RL 5x5
C402	157B-107M-5-KMK	CE 6.3V 100µF 20% RL
C403,C404	15CH-330J-5-IG	CTC 0/60 33pF 5% RL 5x4
C407	157D-108M-5-S9K	CE 16V 1000µF 20% RL
C408	157D-226M-5-GMK	CE 16V 22µF 20% RL
C409	150F-104K-5-II	CC 50V 0.1µF 10% RL 5x5
C410	157D-106M-5-GMK	CE 16V 10µF 20% RL 4x7
C411	153F-103J-5-IM	CM 50V 0.01µF 5% RL 5X7
C412,C413	150F-104K-5-II	CC 50V 0.1µF 10% RL 5x5
C414,C415	15CH-270J-5-GG	CTC 0/60 27pF 5% RL 4x4
C416,C417	150F-104K-5-II	CC 50V 0.1µF 10% RL 5x5
C418	157D-106M-5-GMK	CE 16V 10µF 20% RL 4x7
C419	153F-103J-5-IM	CM 50V 0.01µF 5% RL 5X7
C420	157D-106M-5-GMK	CE 16V 10µF 20% RL 4x7
C440	150F-104K-5-II	CC 50V 0.1µF 10% RL 5x5
C450	150F-104K-2-FC	CC 50V 0.1µF 10% AT
C451	150F-103K-5-II	CC 50V 0.01µF 10% RL 5x5
C501-C505	150F-104K-5-II	CC 50V 0.1µF 10% RL 5x5
C506,C507	157E-108M-5-5\$F3	CE 25V 1000µF 20% RL
C508	157C-108M-5-S5K	CE 10V 1000µF 20% RL
C510	157F-107M-5-OVK	CE 50V 100µF 20% RL
C511	157C-227M-5-OMK	CE 10V 220µF 20% RL 8x7
C512,C513	157E-106M-5-luf3	CE 25V 10µF 20% RL 5X11
C521	157F-226M-5-IUK	CE 50V 22µF 20% RL 5X11
C522	157Q-476M-5-LUA	CE 35V 47µF 20% RL 6.5X11
C525	157D-477M-5-X9F3	CE 16V 470µF 20% RL
C526	150F-104K-5-II	CC 50V 0.1µF 10% RL 5x5
C527	157C-108M-5-X&F3	CE 10V 1000µF 20% RL
C528	150F-104K-5-II	CC 50V 0.1µF 10% RL 5x5
C529	157D-338M-5-5&K	CE 16V 3300µF 20% RL
C532	150F-104K-5-II	CC 50V 0.1µF 10% RL 5x5
C533	157C-108M-5-S5K	CE 10V 1000µF 20% RL
C534,C535	150F-104K-5-II	CC 50V 0.1µF 10% RL 5x5

Reference No.	Part No.	Description
C537,C538	157E-106M-5-luf3	CE 25V 10μF 20% RL 5X11
C539	153F-103K-5-IM	CM 50V 0.01μF 10% RL 5x7
C540-C543	150F-104K-5-II	CC 50V 0.1μF 10% RL 5x5
C544	153F-103K-5-IM	CM 50V 0.01μF 10% RL 5x7
C545,C546	150F-104K-5-II	CC 50V 0.1μF 10% RL 5x5
C560,C561	157E-107M-5-KUK	CE 25V 100μF 20% RL
C701	153F-103K-5-IM	CM 50V 0.01μF 10% RL 5x7
C702	157C-476M-5-IMK	CE 10V 47μF 20% RL 5X7
C703	150F-104K-5-II	CC 50V 0.1μF 10% RL 5x5
C704	153F-103J-5-IM	CM 50V 0.01μF 5% RL 5X7
C710	157B-107M-5-KMK	CE 6.3V 100μF 20% RL
C713	153F-223K-5-LQ	CM 50V 0.022μF 10% RL 6.
DIODES		
D101, D301-D302, D401-D402	4804-1480-2	DIODE 1N4148 AT
D403	4837-3V31-2	DZ 1/2W 3.1-3.5V ROHM AT
D409, D411-D415, D426, D431	4804-1480-2	DIODE 1N4148 AT
D501-D504	4804-0010-2	DIODE 1N4001 AT
D505	4840-1140-0	ZD 1.3W 3.3V 5% AT
D506-D508	4804-0010-2	DIODE 1N4001 AT
D510	4840-0850-0	ZD 1/2W 21.52-22.63V AT
D511	4837-5V61-2	DZ 1/2W 5.6V ROHM AT
D514-D517	4804-0010-2	DIODE 1N4001 AT
COILS		
J507, L101	1801-100K-M	COIL 10μH 10% BL7.0
L301	1802-0450-0	DIGITAL COIL 015-910-27BB
CRYSTAL		
M302	2300-1910-0	X'TAL 16.9344MHZ +/-30PPM AT-51
M303	2704-0060-0	EMC FILTER
M401, M402	2703-6190-0	CR REASONATOR CSA 12MHz
JACKS		
M317	2113-1300-0	2P RCA JACK W/R AU W/SHIELD
M318	2113-1170-0	1P RCA JACK YL AU HTJ-032-0
M319	2113-1121-0	2P RCA JACK Y/Y AU HSP-24V-22
TRANSISTORS		
Q101	4851-015Y-5	TR 2SA1015-Y HFE120-240
Q301-Q304	4860-1780-5	TR 2SD655F HFE:600-1200
Q305	485A-1346-5	TR 2SA1346 HFE 50-100
Q308	4860-1780-5	TR 2SD655F HFE:600-1200
Q401	4860-0660-5	TR 2SA1015 (G.R.) RL
Q402	4851-012F-5	TR 2SD1012F/G HFE 160-560
Q403	4860-0660-5	TR 2SA1015 (G.R.) RL
Q502	485A-950Y-5	TR 2SA950-Y HFE 100-200
RESISTORS		
D701	4701-752J-C	RCF 1/8W 7.5K 5% ATS
J519	4715-4R75-2	RMF 1/4W 4.75R 1% AT
R101	4701-154J-C	RCF 1/8W 150K 5% ATS
R102	4701-682J-C	RCF 1/8W 6.8K 5% ATS
R103	4701-222J-C	RCF 1/8W 2.2K 5% ATS
R106	4701-331J-C	RCF 1/8W 330R 5% ATS
R107	4701-273J-C	RCF 1/8W 27K 5% ATS
R108	4701-153J-C	RCF 1/8W 15K 5% ATS
R109	4701-104J-C	RCF 1/8W 100K 5% ATS
R110	4701-222J-C	RCF 1/8W 2.2K 5% ATS

<u>Reference No.</u>	<u>Part No.</u>	<u>Description</u>
R111	4701-203J-C	RCF 1/8W 20K 5% ATS
R112	4701-223J-C	RCF 1/8W 22K 5% ATS
R113	4701-153J-C	RCF 1/8W 15K 5% ATS
R116	4701-393J-C	RCF 1/8W 39K 5% ATS
R117	4701-152J-C	RCF 1/8W 1.5K 5% ATS
R118	4701-103J-C	RCF 1/8W 10K 5% ATS
R120	4701-333J-C	RCF 1/8W 33K 5% ATS
R121,R123	4701-563J-C	RCF 1/8W 56K 5% ATS
R124	4701-102J-C	RCF 1/8W 1K 5% ATS
R125	4701-103J-C	RCF 1/8W 10K 5% ATS
R126	4701-682J-C	RCF 1/8W 6.8K 5% ATS
R131	4701-153J-C	RCF 1/8W 15K 5% ATS
R132	4701-183J-C	RCF 1/8W 18K 5% ATS
R133	4701-331J-C	RCF 1/8W 330R 5% ATS
R134	4701-102J-C	RCF 1/8W 1K 5% ATS
R135	4701-103J-C	RCF 1/8W 10K 5% ATS
R137	4701-200J-C	RCF 1/8W 20R 5% ATS
R138	4701-102J-C	RCF 1/8W 1K 5% ATS
R139	4701-472J-C	RCF 1/8W 4.7K 5% ATS
R201	4701-682J-C	RCF 1/8W 6.8K 5% ATS
R204	4701-103J-C	RCF 1/8W 10K 5% ATS
R207,R208	4701-562J-C	RCF 1/8W 5.6K 5% ATS
R301	4701-681J-C	RCF 1/8W 680R 5% ATS
R302	4701-563J-C	RCF 1/8W 56K 5% ATS
R303	4701-122J-C	RCF 1/8W 1.2K 5% ATS
R305	4701-104J-C	RCF 1/8W 100K 5% ATS
R307	4701-103J-C	RCF 1/8W 10K 5% ATS
R317	4701-102J-C	RCF 1/8W 1K 5% ATS
R320	4701-471J-C	RCF 1/8W 470R 5% ATS
R330	4701-752J-C	RCF 1/8W 7.5K 5% ATS
R355,R356	4701-362J-2	RCF 1/8W 3.6K 5% AT
R359,R360	4701-163J-2	RCF 1/8W 16K 5% AT
R363,R364	4701-152J-C	RCF 1/8W 1.5K 5% ATS
R367,R368	4701-222J-C	RCF 1/8W 2.2K 5% ATS
R371,R372	4701-222J-C	RCF 1/8W 2.2K 5% ATS
R373,R374	4701-104J-C	RCF 1/8W 100K 5% ATS
R375,R376	4701-750J-C	RCF 1/8W 75R 5% ATS
R377,R378	4701-472J-C	RCF 1/8W 4.7K 5% ATS
R379,R380	4701-750J-C	RCF 1/8W 75R 5% ATS
R381,R382	4701-472J-C	RCF 1/8W 4.7K 5% ATS
R383	4701-151J-C	RCF 1/8W 150R 5% ATS
R384	4701-750J-C	RCF 1/8W 75R 5% ATS
R390	4717-221J-C	RMF 1/2W 220R 5% ATS
R391-R393	4717-221J-C	RMF 1/2W 220R 5% ATS
R394-R397	4701-472J-C	RCF 1/8W 4.7K 5% ATS
R401,R402	4701-104J-C	RCF 1/8W 100K 5% ATS
R403	4701-103J-C	RCF 1/8W 10K 5% ATS
R404	4701-102J-C	RCF 1/8W 1K 5% ATS
R405	4701-223J-C	RCF 1/8W 22K 5% ATS
R406	4701-752J-C	RCF 1/8W 7.5K 5% ATS
R407	4701-472J-C	RCF 1/8W 4.7K 5% ATS
R408,R409	4701-101J-C	RCF 1/8W 100R 5% ATS
R410	4701-104J-C	RCF 1/8W 100K 5% ATS
R411	4701-101J-C	RCF 1/8W 100R 5% ATS
R412	4701-472J-C	RCF 1/8W 4.7K 5% ATS
R413	4701-473J-C	RCF 1/8W 47K 5% ATS
R414	4701-104J-C	RCF 1/8W 100K 5% ATS
R415	4701-752J-C	RCF 1/8W 7.5K 5% ATS
R416	4701-473J-C	RCF 1/8W 47K 5% ATS

<u>Reference No.</u>	<u>Part No.</u>	<u>Description</u>
R418,R419	4701-272J-C	RCF 1/8W 2.7K 5% ATS
R420-R427	4701-472J-C	RCF 1/8W 4.7K 5% ATS
R428	4701-561J-C	RCF 1/8W 560R 5% ATS
R501,R502	4701-241J-C	RCF 1/8W 240R 5% ATS
R503,R504	4701-222J-C	RCF 1/8W 2.2K 5% ATS
R517,R518,R520	4701-471J-C	RCF 1/8W 470R 5% ATS
R523	4701-473J-C	RCF 1/8W 47K 5% ATS
R701,R702	4701-472J-C	RCF 1/8W 4.7K 5% ATS
R702	4701-472J-C	RCF 1/8W 4.7K 5% ATS
ICS		
U101	3130-6710-0	IC LA9240 ASP FOR CD QIP64E
U201	3130-6720-0	IC LA6541D 4-CHANNEL BTL DRIVER DIP30SLF
U301	3130-6700-0	IC LC78621ED DSP FOR CD QIP80E
U302	3131-9380-0	IC PCM1732 HDCD D/A CONVERTER
U305, U306	3130-9340-0	IC OPA2604 OPAMP DIP8 BURR-BROWN
U401	3130-9330-1	IC LC866008C MICRO MASK QFP64 SANYO
U402	3130-9320-0	IC NADLINK (MASKED) MICROCONTROLLER
U403	3130-4160-0	IC TC74HC00 NAND GATE
U501, U506	3130-2020-3	IC 7805 REG 5V 1.5A
U502	3130-5610-0	IC LM317T+ADJ REGULATOR
U503	3130-5620-0	IC LM337T-ADJ REGULATOR
U507	3130-2790-1	IC NJM7808FA +8V REG TO-220F
U701	3130-6560-0	IC LB1641 MOTOR DRIVER

- NOTE:**
- The components identified by \triangle mark are critical for risk of fire and electrical shock. Replace only with part number specified.
 - <*AH > : USA, Canadian model only.
 - <*C > : European model only.
 - Capacitors : CP-Polystyrene, CM-Mylar, CE-Electrolytic, CC-Ceramic, CTC-NPO.
 - Resistors : RMF-Metal Film, RCF- Carbon Film.

MECHANISM EXPLODED VIEW

CD11CA

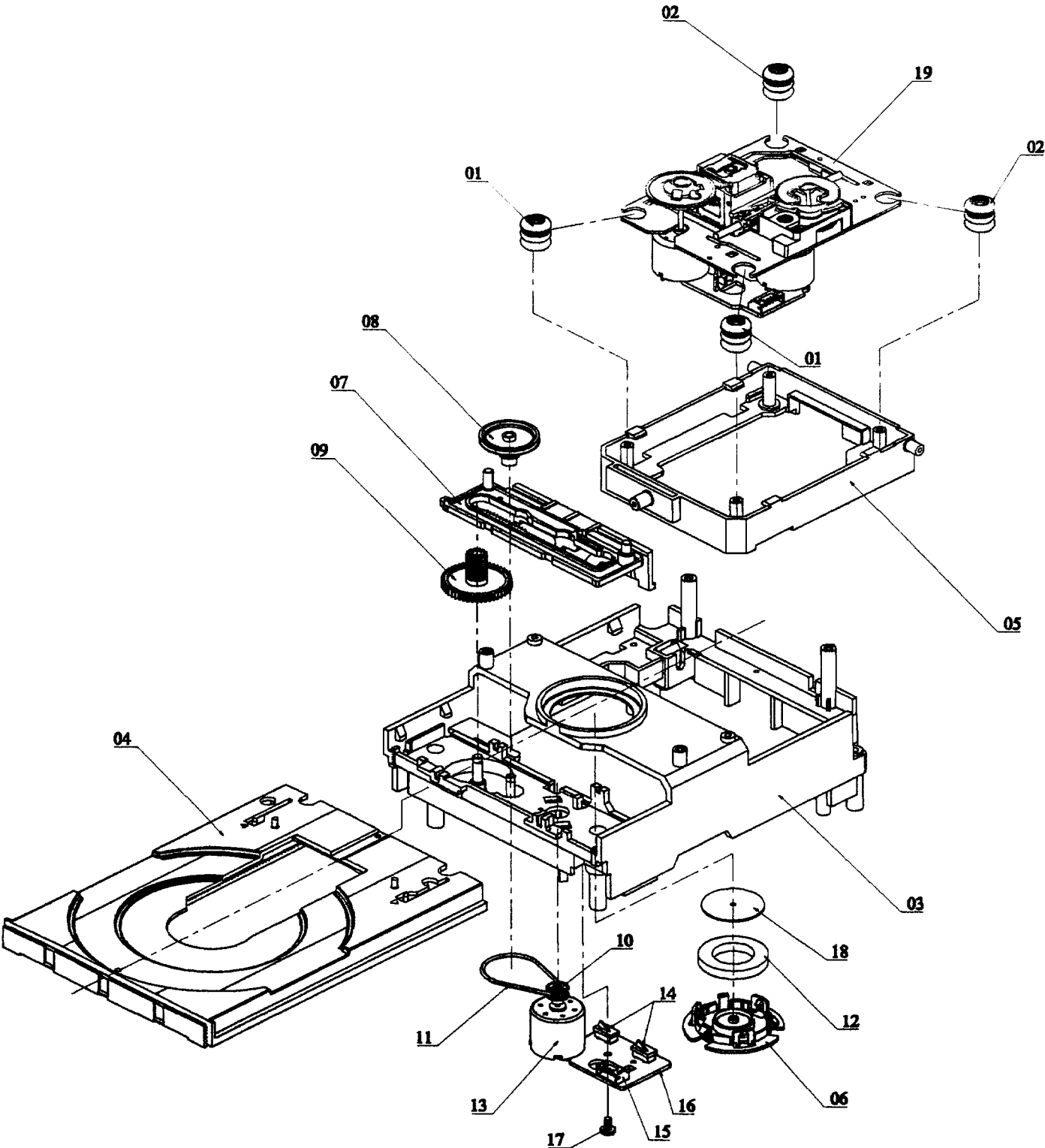

MECHANISM EXPLODED VIEW PARTS LIST

<u>ITEM</u>	<u>Part No.</u>	<u>Description</u>	<u>Qty</u>
1	4102-6101-0	RUBBER CUSHION (HARD)	2
2	4102-6102-0	RUBBER CUSHION (SOFT)	2
3	4102-6103-0	BASE	1
4	4102-6104-0	TRAY	1
5	4102-6105-0	CDM MOUNTING BASE	1
6	4102-6106-0	MAGNET HOLDER	1
7	4102-6107-0	SLIDE GEAR	1
8	4102-6108-0	PULLEY GEAR	1
9	4102-6109-0	DRIVE GEAR	1
10	4102-6110-0	PULLEY MOTOR	1
11	4102-6111-0	SQUARE BELT	1
12	4102-6112-0	MAGNET	1
13	4102-6113-0	LOADING MOTOR	1
14	4102-6114-0	SWITCH PUSH 2-1	2
15	4102-6115-0	CON JST 5P RT	1
16	4102-6116-0	MOTOR/SW.PCB	1
17	4102-6117-0	SCREW M3.0X8.0	1
18	4102-6118-0	PLATE MAGNET	1
19	4102-6213-0	LASER CD11CA-G	1

EXPLODED VIEW OF LASER CD11CA-G

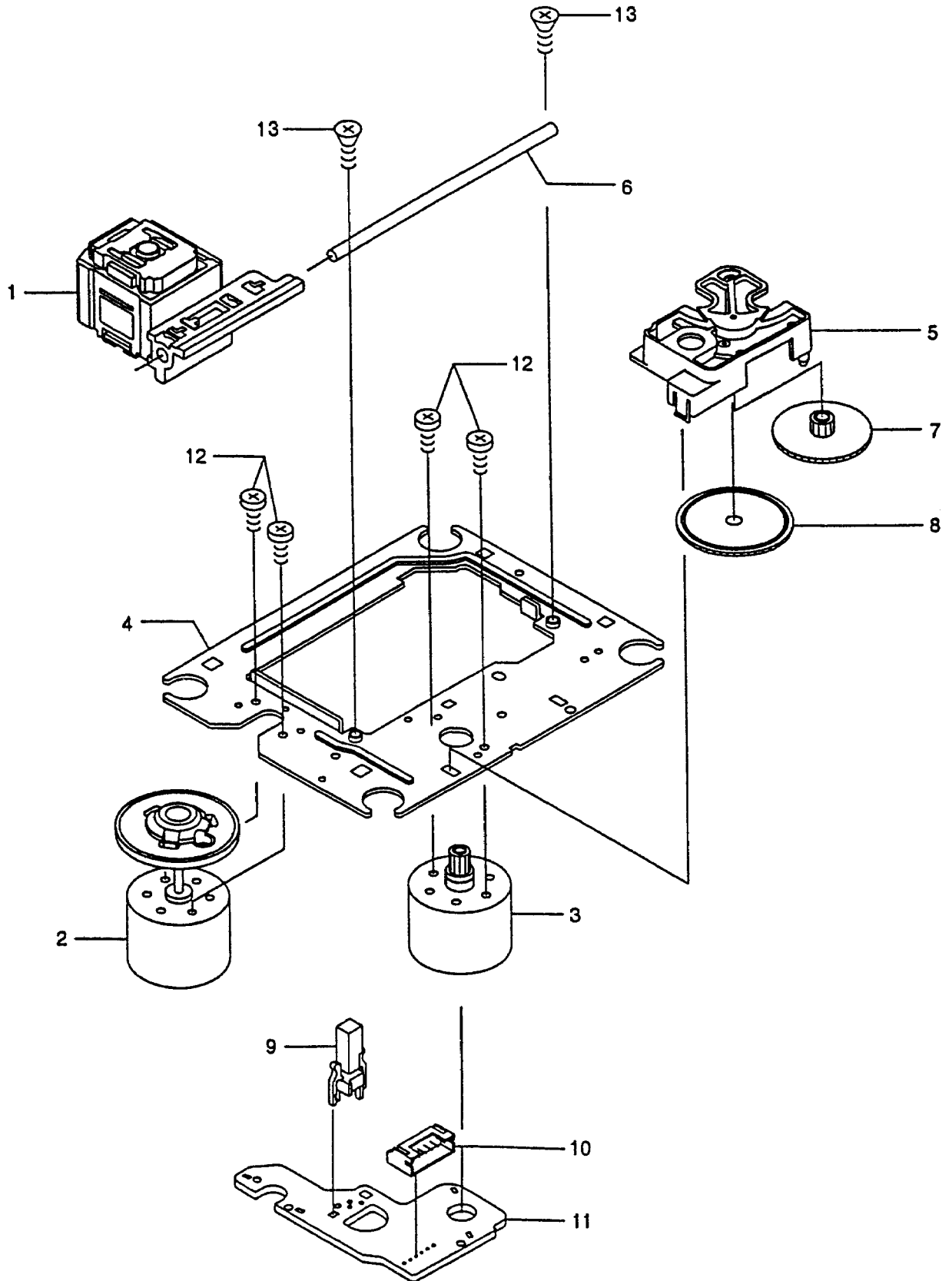

EXPLODED VIEW PARTS LIST OF LASER CD11CA-G

<u>ITEM</u>	<u>Part No.</u>	<u>Description</u>	<u>Qty</u>
1	4102-6214-0	ASSY PICKUP LASER P101N	1
2	4102-6215-0	ASSY MOTOR 6.0V SPINDLE	1
3	4102-6216-0	ASSY MOTOR SLED 6.0V	1
4	4102-6217-0	CHASSIS	1
5	4102-6218-0	COVER GEAR	1
6	4102-6219-0	SHAFT SLIDE	1
7	4102-6220-0	GEAR MIDDLE	1
8	4102-6221-0	GEAR DRIVE	1
9	4102-6222-0	SWITCH LEAF(PWB MOTOR)	1
10	4102-6223-0	PLUG 6P	1
11	4102-6224-0	PWB MOTOR	1
12	4102-6225-0	SCREW PAN PCS 2x3	4
13	4102-6226-0	SCREW SELF-TAPING FLT 2.6x6	2

EXPLODED VIEW

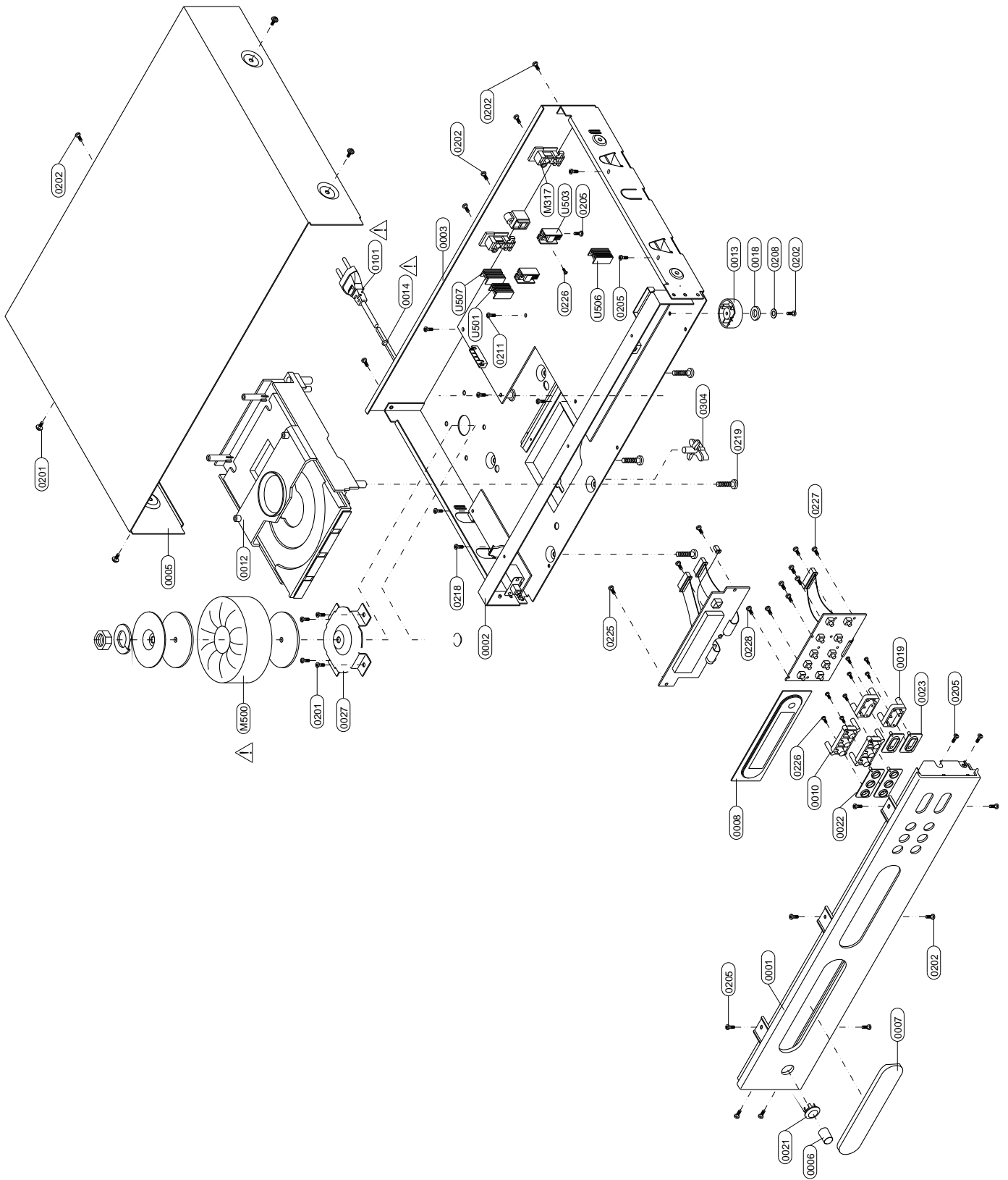

EXPLODED VIEW PARTS LIST

ITEM	Part No.	Description	Qty
0001	1465-5704-2	FASCIA W/SS PAINT	1R
0002	1402-3781-2	STRAP	1
0003*AH	1402-3518-0	CHASSIS W/SS PAINT	1
0003*C	1402-3519-0	CHASSIS W/SS PAINT	1
0005	1402-3530-0	COVER	1
0006	2442-1000-0	POWER BUTTON	1
0007	1464-6011-3	CD DOOR W/SS PAINT	1
0008	3716-4316-0	WINDOW LENS W/SS	1
0010	2444-1201-0	BUTTON TRIO	2
0012	4111-1131-0	CD DECK	1
0013	4152-4631-0	RUBBER FOOT 14MM HIGH	4
0014 \triangle	4151-9461-0	STRAIN RELIEF BUSHING 4N-4	1
0018	4152-4641-0	CUSHION FOOT	4
0019	2444-1301-1	BUTTON RACKER	2
0021	4152-4331-0	POWER BUTTON BEZEL	1
0022	4154-0031-0	BEZEL TRIO	2
0023	4154-0091-0	BEZEL RACKER	2
0027	4104-3721-0	TRANSFORMER BRACKET	1
0101*AH \triangle	7009-3100-2	AC CORD 18AWGX2 SPT-2 D.INSULATED UL/CSA	1
0101*C \triangle	7009-3110-0	AC CORD SEMKO	1
0201	2900-4006-3010	M4X0.5PX6MM W/FLAT WASHER	8
0202	2954-3008-3000	T3X8MM SELF TAPPING	12
0205	2954-3008-0000	TAPPING 3X8MM B-TITE(YEL.ZN)	17
0208	2842-3367-0	METAL WASHER ID=3.3 OD=6.7	4
0211	2904-3006-0000	SCREW M3X6	4
0218	2954-3006-0000	3X6MM B-TITE (YEL.ZN)	2
0219	2954-4010-3000	SCREW TAP-C2 BH M4X10MM BZ CROSS	4
0226	2954-2006-0000	TAPPING SCREW 2X6	13
0227	2954-2608-0000	SCREW BT 2.6X8	7
0228	2950-2608-3000	SCREW PAN HEAD,B-TITE 2.6X8 BLACK	1
0304	1463-160B-0	CD TRANSIT LOCK (RED)	1
M500 \triangle	1806-2512-0	TRANSFORMER I/P 120/230V	1
U501-U503	5400-9130-0	HEAT SINK FOR 7805 2438-17	3
U506-U507	5400-9130-0	HEAT SINK FOR 7805 2438-17	2

- NOTE:**
- The components identified by \triangle mark are critical for risk of fire and electrical shock. Replace only with part number specified.
 - <*AH > : USA, Canadian model only.
 - <*C > : European model only.

PACKING DIAGRAM

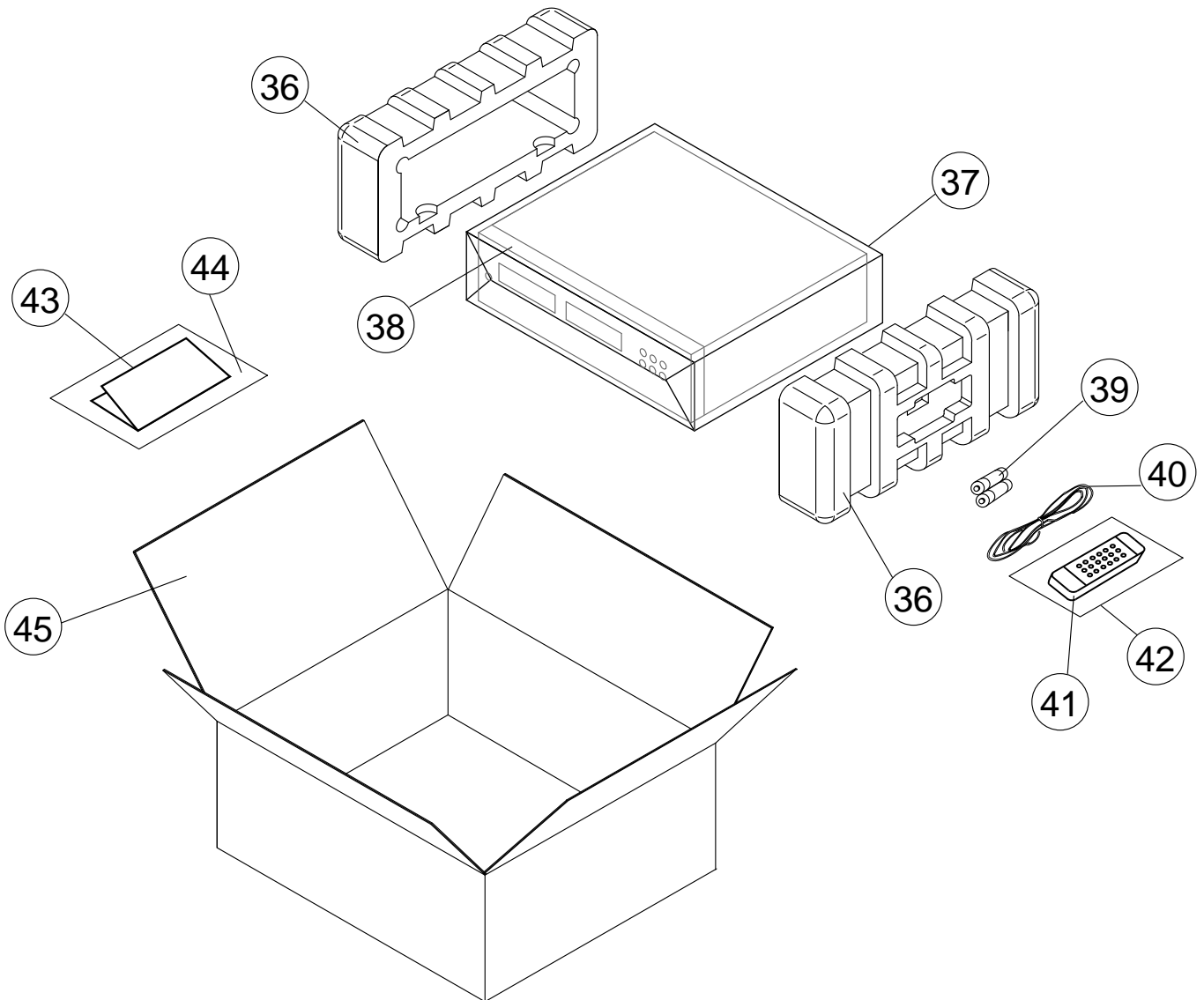

ITEM	PART NO.	DESCRIPTION	Q'TY
36	1490-3783-0	POLYFOAM ENDCAP	2
37	1497-1332-1	UNIT POLYBAG	1
38	1497-1432-0	FASCIA COVER	1
39	4060-0530-0	BATTERIES	2
40	2103-7302-1	RCA CABLE	1
41	8900-2166-0	REMOTE CONTROL HANDSET	1
42	1497-1302-1	REMOTE CONTROL POLYBAG	1
43	4301-4105-0	INSTRUCTION MANUAL	1
44	1497-1062-0	MANUAL POLYBAG	1
45	1435-4200-1-2	CARTON BOX	1

Proprietary information for servicing purposes only. The information herein may not be used commercially without the prior written agreement of NAD Electronics International, Toronto, Canada.

SERVICE MANUAL

C 541

**COMPACT
DISC PLAYER**

© NAD 2001

**NAD ELECTRONICS INTERNATIONAL
TORONTO**