

C 521i

**COMPACT
DISC PLAYER**

C 521i

**COMPACT
DISC PLAYER**

SERVICE MANUAL



SAFETY INFORMATION

CAUTION

CAUTION - INVISIBLE LASER RADIATION WHEN OPEN AND INTERLOCKS DEFEATED. AVOID EXPOSURE TO BEAM.

ADVARSEL - USYNLIG LASERSTRÅLING NÅR DEKSEL ÅPNES OG SIKKERHEDSLÅS BRYTES. UNNGÅ EKSPONERING FOR STRÅLEN.

ADVARSEL - USYNLIG LASERSTRÅLING VED ÅBNING, NÅR SIKKERHEDSAFBRYDERE ER UDE AF FUNKTION. UNDGÅ UDSÆTTELSE FOR STRÅLING.

VARING - OSYNLIG LASERSTRÅLNING NÅR DENNA DEL ÄR ÖPPNAD OCH SPÄRRAR ÄR URKOPPLADE. STRÅLEN ÄR FARLIG.

VARO! - AVATTAESSA JA SUOJALUKITUS OHITETTAESSA OLET ALTTIINA NÄKTMÄTÖNTÄ LASERSÄTELYLLE. ÄLÄ KAISO SÄTEESEEN.

VORSICHT! - UNSICHTBARE LASERSTRAHLUNG TRITTT AUS, WENN DECKEL GEÖFFNET UND WENN SICHERHEITVERRIEGELUNG ÜBERBRÜCKT IST. NICHT DEM STRAHL AUSSETZEN.

**CLASS 1
LASER PRODUCT**

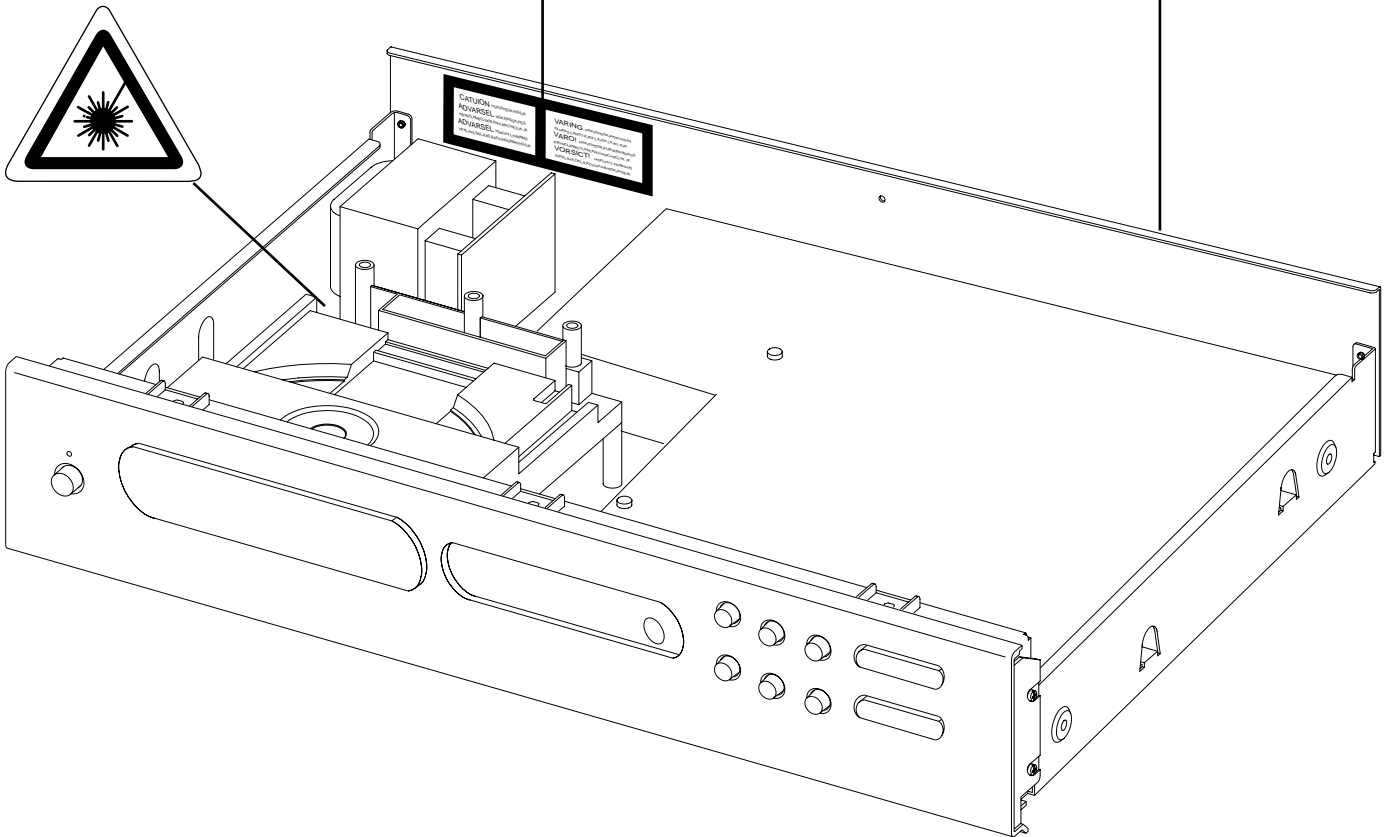

The lightning flash with arrowhead, within an equilateral triangle is intended to alert the user of the presence of uninsulated "dangerous voltage" within the product's enclosure; that may be of sufficient magnitude to constitute a risk of electric shock to persons.



The exclamation point within an equilateral triangle is intended to alert the user of the presence of important operating and maintenance (servicing) instructions in the literature accompanying the appliance.

THIS DEVICE COMPLIES WITH PART 15 OF THE FCC RULES. OPERATION IS SUBJECT TO THE FOLLOWING TWO CONDITIONS:-
(1) THIS DEVICE MAY NOT CAUSE HARMFUL INTERFERENCE, AND
(2) THIS DEVICE MUST ACCEPT ANY INTERFERENCE RECEIVED, INCLUDING INTERFERENCE THAT MAY CAUSE UNDESIRED OPERATION.

SERVICE SAFETY PRECAUTIONS

1. Replacing the fuses

CAUTION: FOR CONTINUED PROTECTION AGAINST THE RISK OF FIRE REPLACE ONLY WITH SAME TYPE OF FUSE.

Reference No		Part Number	Description
M502-M504	*AH \triangle	5120-0020-0	FU T1A 250V UL/CSA 5x20MM
M502-M504	*C \triangle	5120-0018-0	FU T1A 250V SEMKO/UDE 5x20MM
M505	*AH \triangle	5120-0052-0	FUSE T1.6A 250V 5x20MM UL/CSA
M505	*C \triangle	5120-0050-0	FUSE T1.6A 250V 5x20MM SEMKO/VDE

NOTE:

<*AH > : USA, CANADIAN MODEL ONLY.

<*C > : EUROPEAN MODEL ONLY.

2. Safety check out

(Only U.S.A. model)

Before returning the product to the customer, make leakage current or resistance measurements to determine that exposed parts are acceptably insulated from the supply circuit.

Parts marked with the symbol \triangle are critical with regard to the risk of fire and electric shock. Replace only with parts recommended by the manufacturer.

CONTENTS

DESCRIPTION	PAGE
SPECIFICATIONS4
REAR PANEL / FRONT PANEL5
DISASSEMBLY INSTRUCTIONS6
BLOCK DIAGRAM7
WIRING DIAGRAM8
RF PATTERN TESTING9
IMPORTANT NOTES10-11
PCB LAYOUT12-14
SCHEMATIC DIAGRAM15-21
IC BLOCK DIAGRAM22-25
TROUBLESHOOTING GUIDE26
ELECTRICAL PARTS LIST27-31
MECHANISM EXPLODED VIEW32
MECHANISM EXPLODED VIEW PARTS LIST33
EXPLODED VIEW35
EXPLODED VIEW PARTS LIST35
PACKING DIAGRAM36

SPECIFICATIONS

Disc Capacity	One Disc, 120 or 80 mm
Decoding	BURR-BROWN Delta Sigma 20bit
Digital Filter	8 Times oversample
Analog Filter	4 pole active
Frequency Response	+/- 0.5 dB, 5Hz - 20kHz
De-Emphasis Error	+/- 0.3 dB
THD (at 0 dB, 1kHz)	0.003%
Intermodulation Distortion (19 + 20 kHz)	< - 100 dB
Dynamic Range	96 dB
Linearity	+/- 0.5 dB, 0 dB to -80 dB
Signal / Noise Ratio (A-Weight)	≥106 dB, De-Emphasis on ≥106 dB, De-Emphasis off
Channel Separation 1kHz	>90 dB
10 kHz	>80 dB
Wow and Flutter	Unmeasurable (Quartz Crystal Accuracy)
Output Impedance	200 Ω
Output Level at 0 dB	2.1 V rms
Digital Error Correction	IRC with double error correction in C1 and C2
Digital Code Output	Sony / Philips Serial data format
Power Consumption	12W

CONTROLS

Play / Pause, Stop, Random, Skip (< >), Scan (< >), Open, Time, Repeat.

PHYSICAL SPECIFICATIONS

Dimensions (Width x Height x Depth)	435 x 80 x 285 mm
Net weight	4 kg (8.8 lbs)
Shipping weight	5.1 kg (11.22 lbs)

REAR PANEL / FRONT PANEL

REAR PANEL

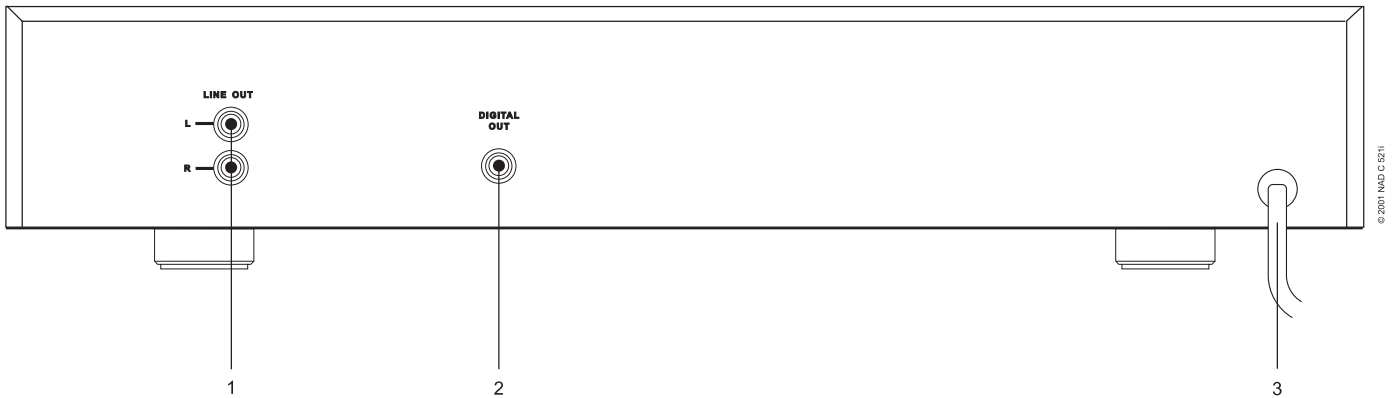

- | | |
|----------------|-----------------|
| 1. LINE OUT | 3. AC LINE CORD |
| 2. DIGITAL OUT | |

FRONT PANEL

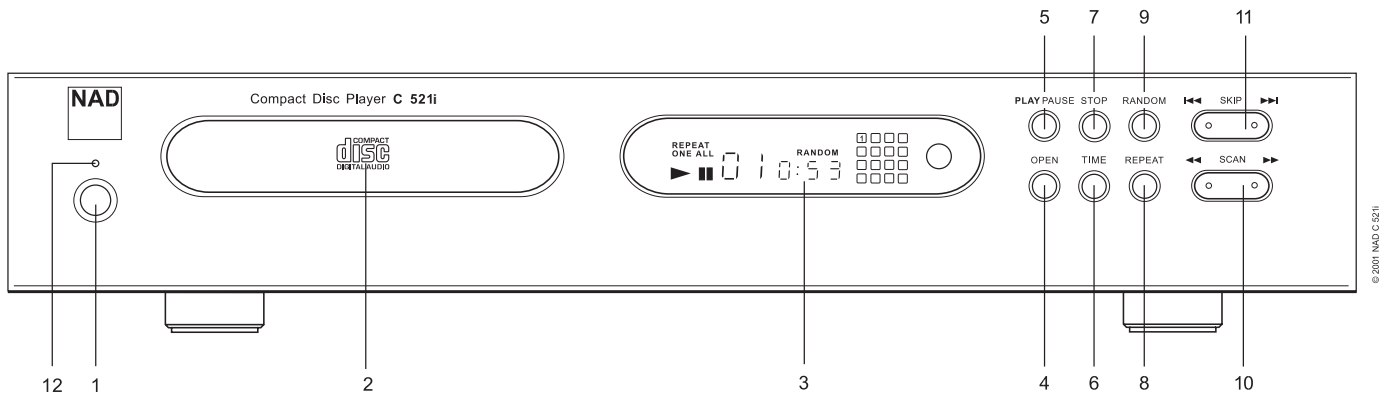

- | | |
|-------------------|-------------------------------------|
| 1. POWER ON / OFF | 7. STOP |
| 2. DISC DRAWER | 8. REPEAT |
| 3. DISPLAY | 9. RANDOM |
| 4. OPEN | 10. SCAN Back (◀◀) / Forward (▶▶) |
| 5. PLAY / PAUSE | 11. SKIP Back (◀◀◀) / Forward (▶▶▶) |
| 6. TIME | 12. STANDBY LED |

DISASSEMBLY INSTRUCTIONS

1. Remove machine screws M 4.0 x 6.0 (① to ④) from the side panels.
Remove tapping screw 3.0 x 8.5 (⑤) from the back panel.
Refer to **Figure No.1**.

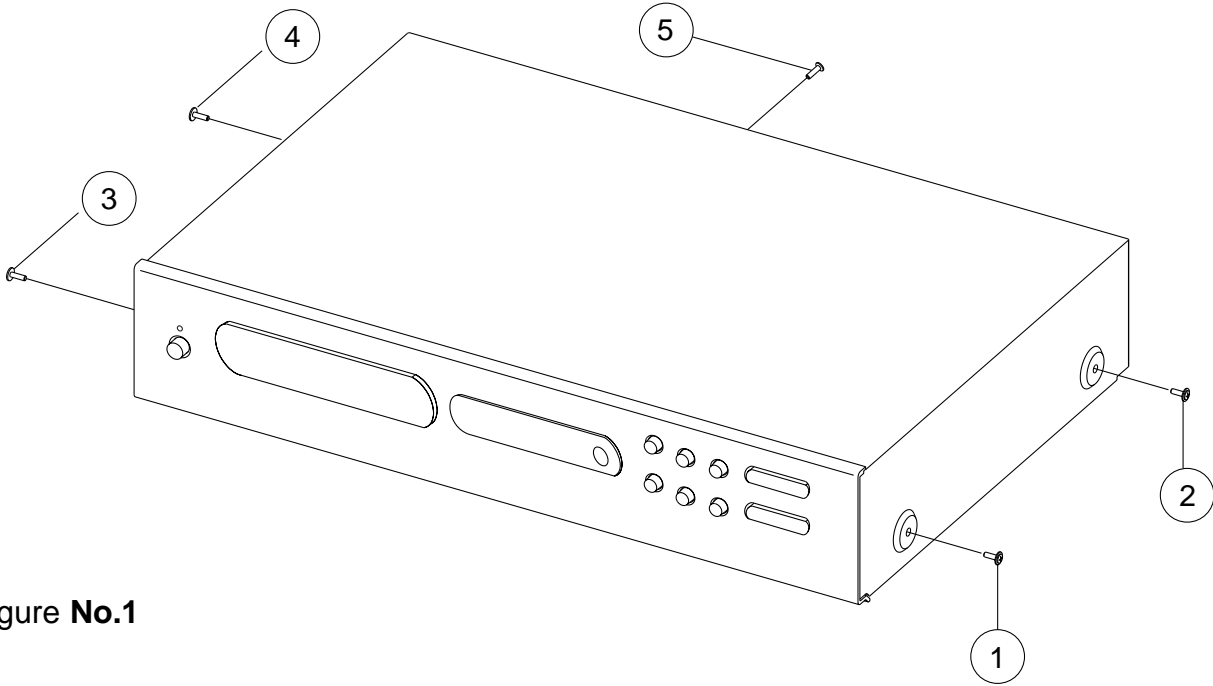

Figure No.1

2. Pull both sides of the TOP COVER slightly outwards (⑥) and tilt approx. 35° and then remove in the direction as indicated by the arrow (⑦). Refer to **Figure No.2**.

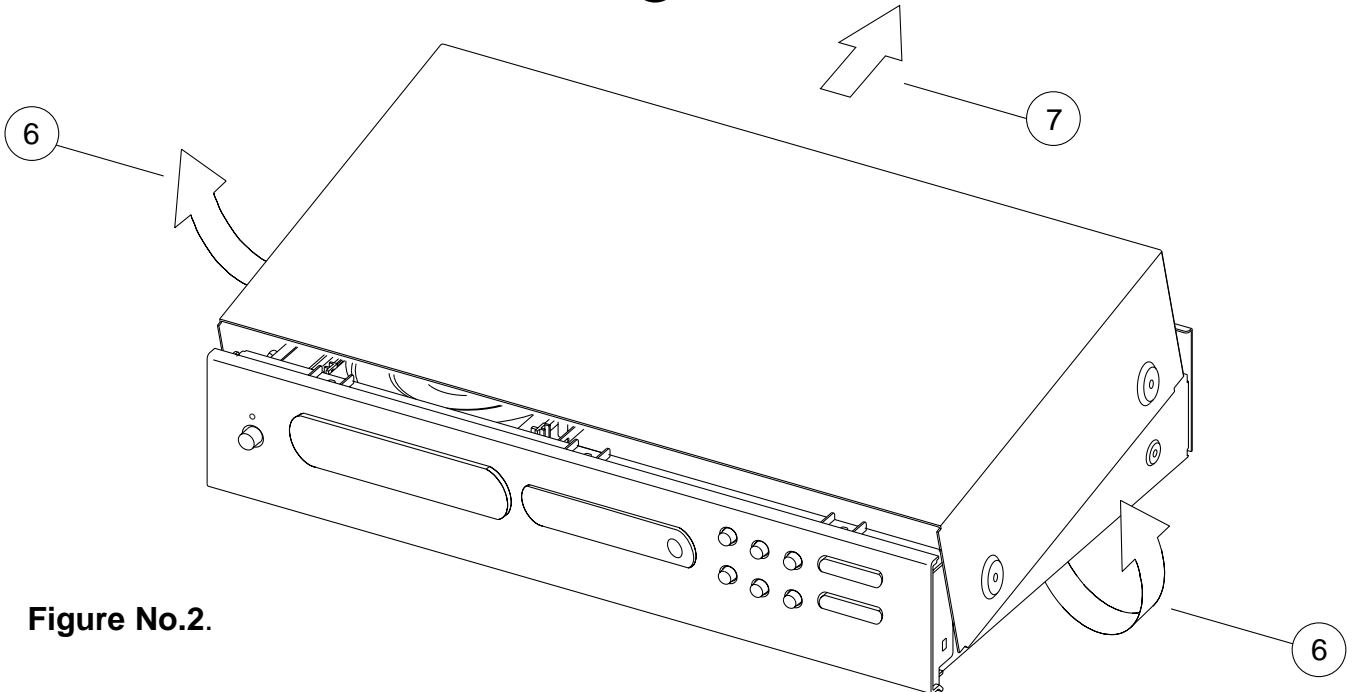
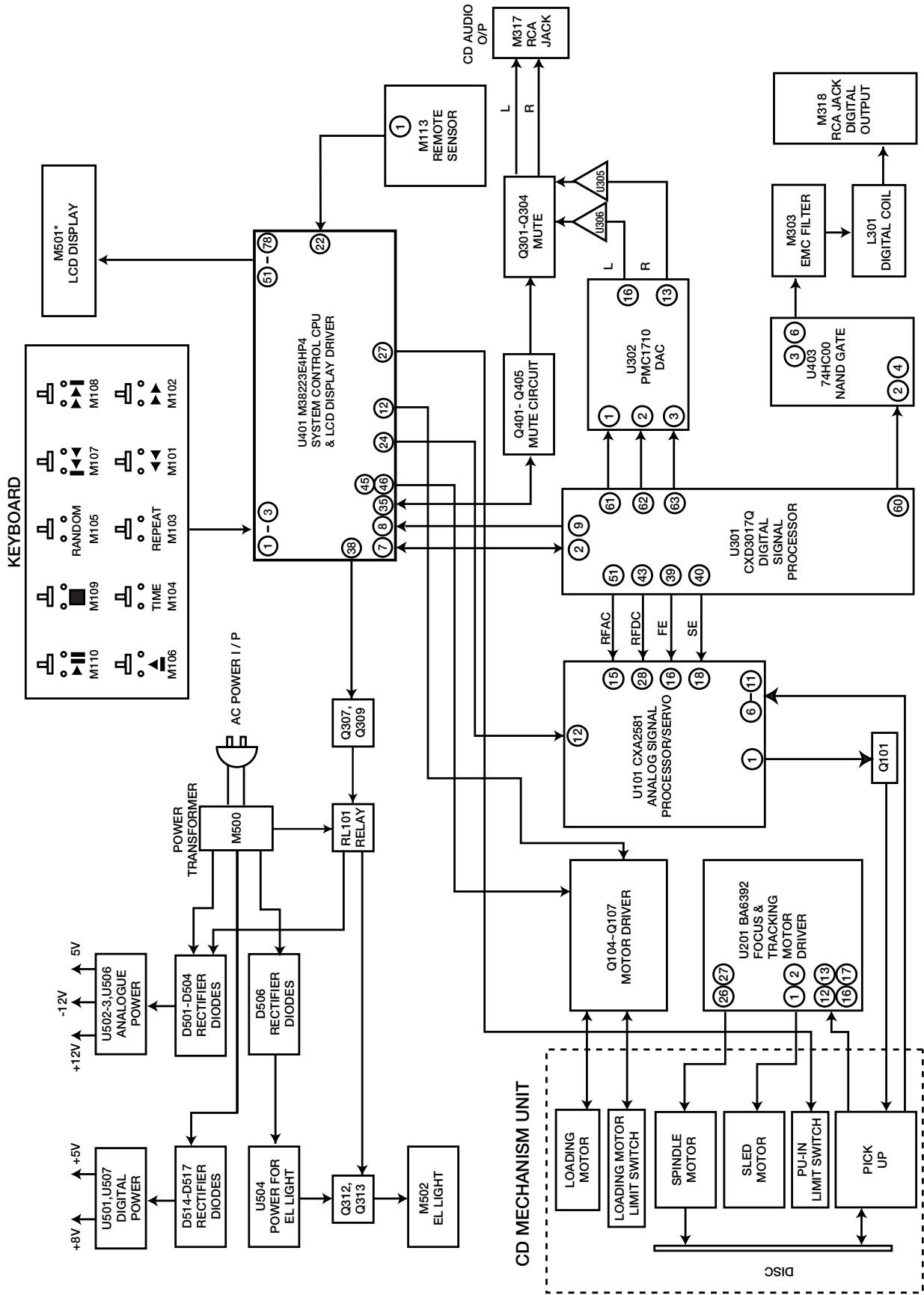

Figure No.2.

BLOCK DIAGRAM



IMPORTANT NOTES

INSTRUCTION FOR HANDLING OPTICAL SYSTEM BLOCK PICK-UP

Electrostatic breakdown of the laser diode in the optical system block may occur due to a potential difference caused by electrostatic charge accumulated on clothing, human body, etc. A ground must be provided as follows to prevent any electrostatic charge during unpacking or repair work.

1. Ground for Human Body

Be sure to wear a ground band (1M ohm) that is properly to remove any static electricity that may be charged on the body.

2. Ground for Work Bench

Be sure to place a conductive sheet (1M ohm) or copper plate with proper grounding on the work bench or other surface on which the pick-up is to be placed.

3. Because the static electricity charge on the clothing does not discharge through the body grounding band, do not let clothing to get in contact with the pick-up unit.

INCORRECT

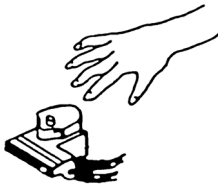

CORRECT

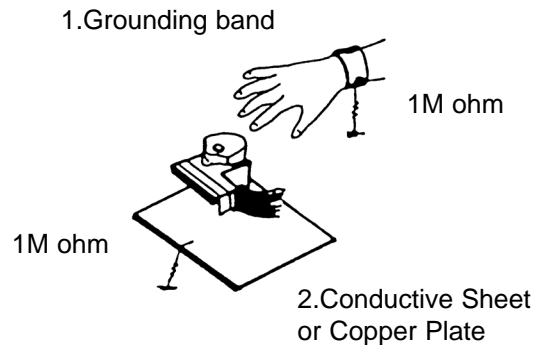

NOTE: Laser diodes are so susceptible to damage from static electricity that even if a static discharge does not ruin the diode, it can shorten its life or cause it to work improperly.

PRECAUTIONS FOR CHECKING BEAM EMISSION

The laser beam of this unit is focused on the reflecting surface of the objective lens in the optical system block. Therefore, keep your eyes at least 12 inches (30 cm) away from the objective lens when the laser diode is **ON**. (Operation Check Method for Laser Diode and Focus Search Function.)

When the **POWER** switch is turned **ON** after the chucking plate is removed, observe the objective lens and confirm that the following operations are performed properly.

(The optical system should be at the lead-in area position when it is checked at this time.)

- (1) The laser should be at the innermost position after the chucking plate is removed.
- (2) The diffused light of the laser beam can be seen when the **POWER** switch is turned **ON**.
- (3) Vertical (up and down) movement of the objective lens (2 or 3 times) will take place.

PRECAUTIONS WHEN CHANGING LASER PICK-UP

When removing the pick-up assembly, short circuit the PCB tracks on the optical block as show in the drawing in order to protect the pick-up before removal.

NOTE: Replacement pick-up assemblies are supplied with the PCB pattern already protected.

DO NOT REMOVE THE SHORT CIRCUITS UNTIL YOU HAVE FINISHED FITTING THE PICK-UP.

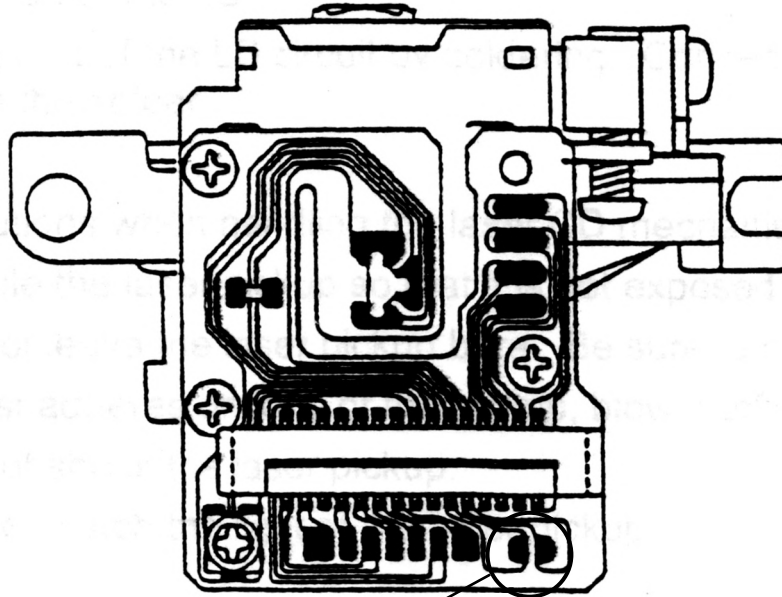

Protective soldering place
for laser diode

Caution:

Laser diodes are extremely susceptible to damage from static electricity. Even if a static discharge does not ruin the diode, it can shorten its life or cause it to work improperly. When replacing the pick-up, use a conductive mat, a grounded soldering iron, and so on, to protect the laser diode from static damage.

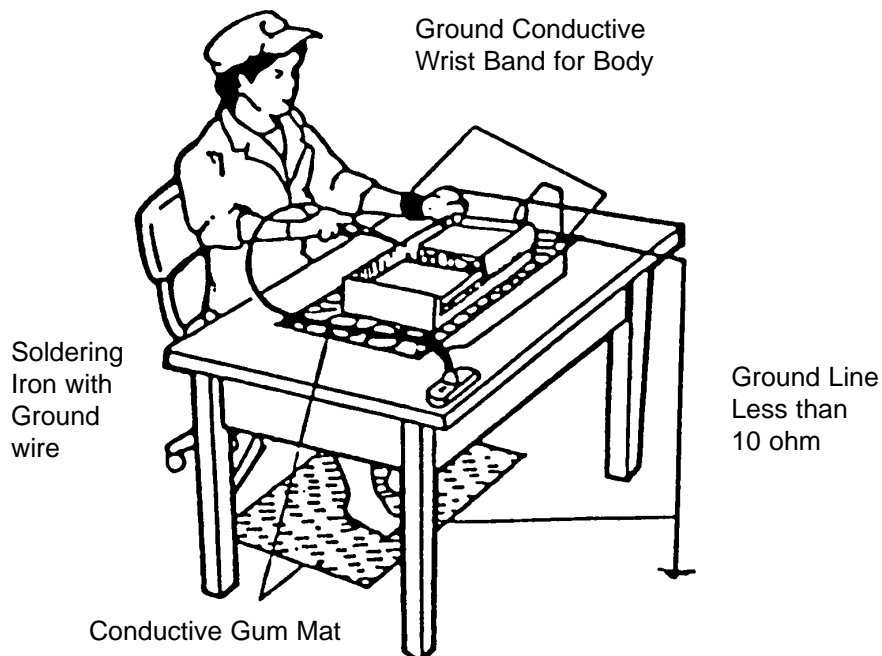

MAIN BOARD

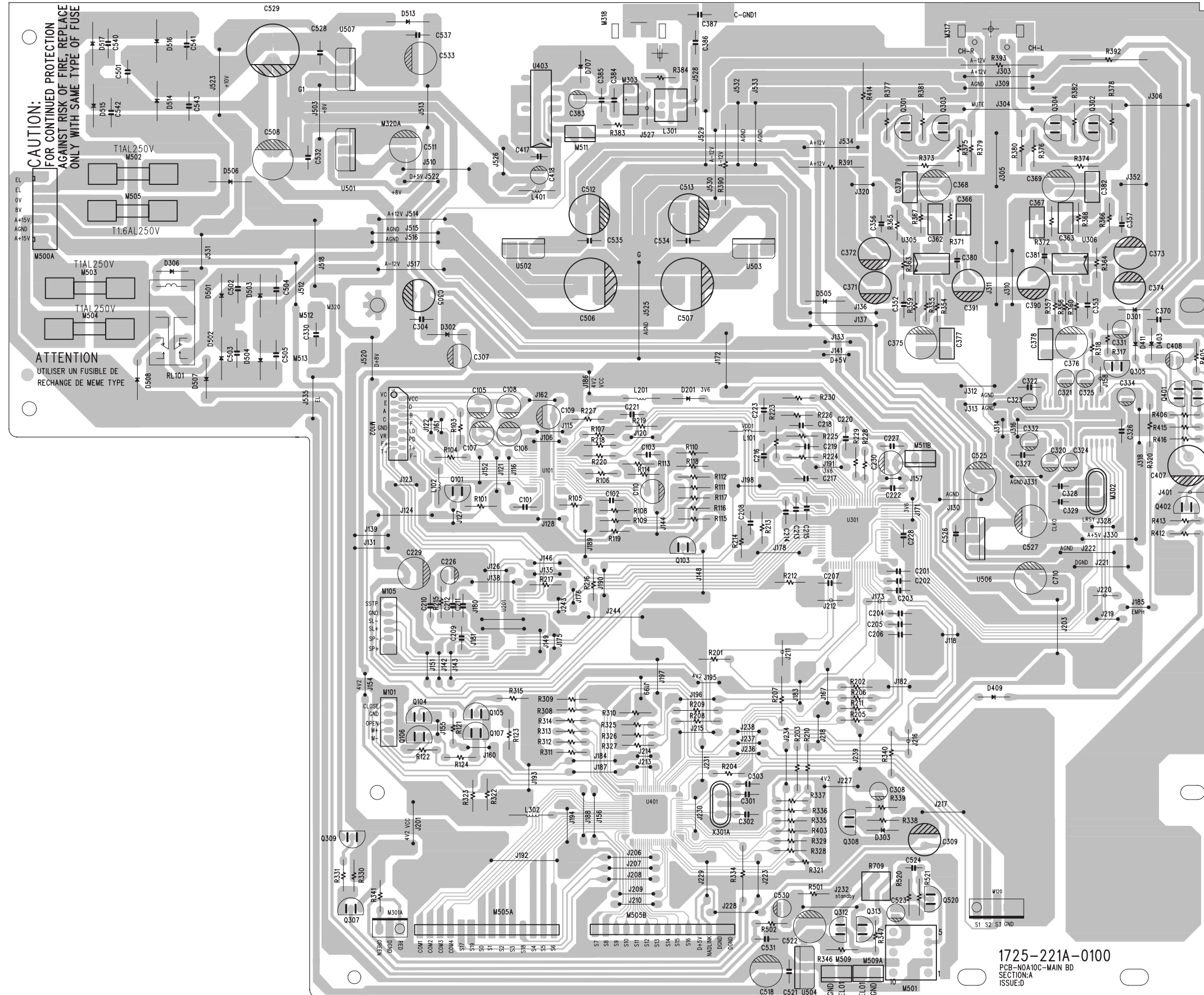

SCHEMATIC DIAGRAM

DISPLAY

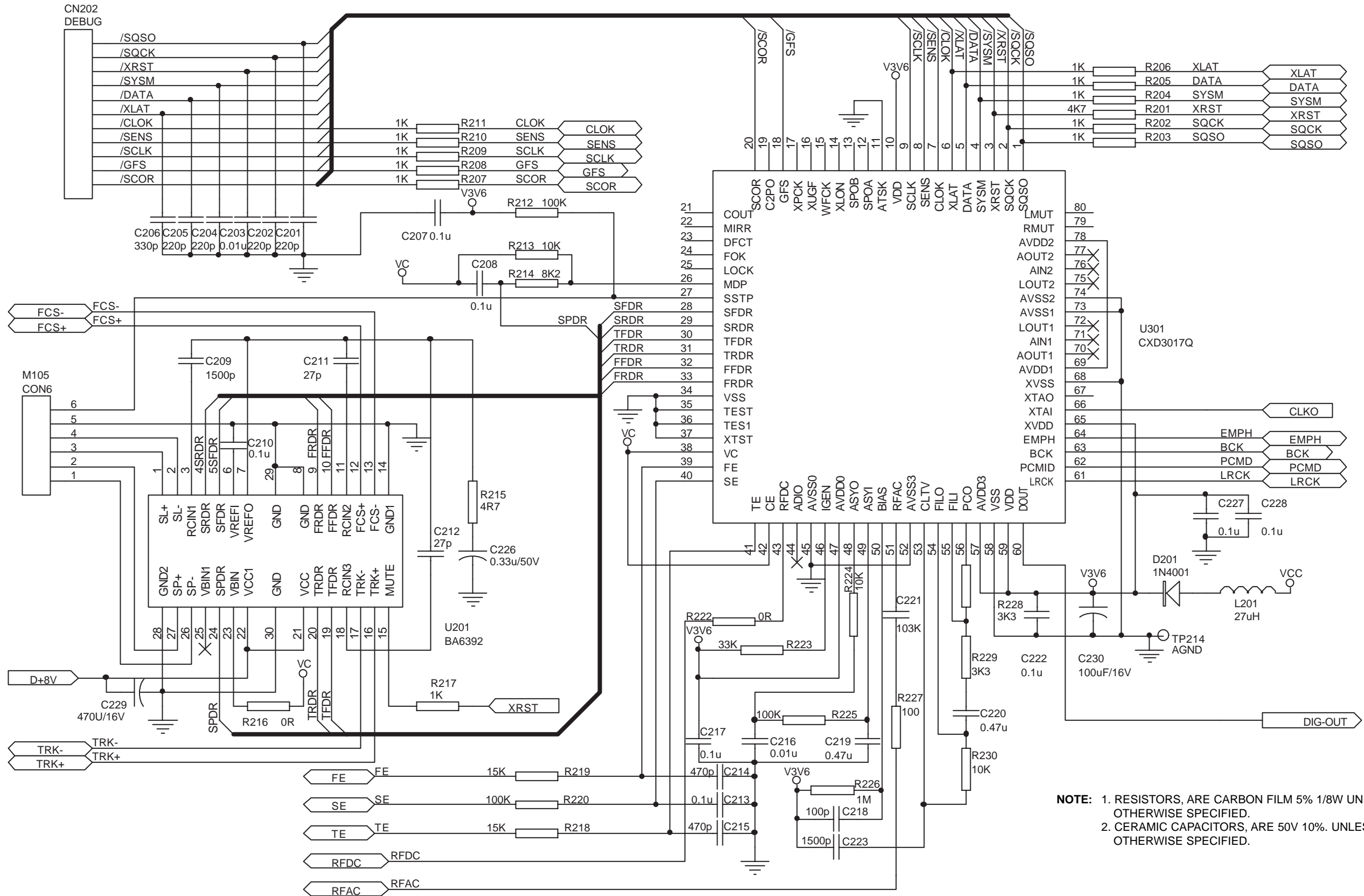

NOTE: 1. RESISTORS, ARE CARBON FILM 5% 1/8W UNLESS OTHERWISE SPECIFIED.
2. CERAMIC CAPACITORS, ARE 50V 10%. UNLESS OTHERWISE SPECIFIED.

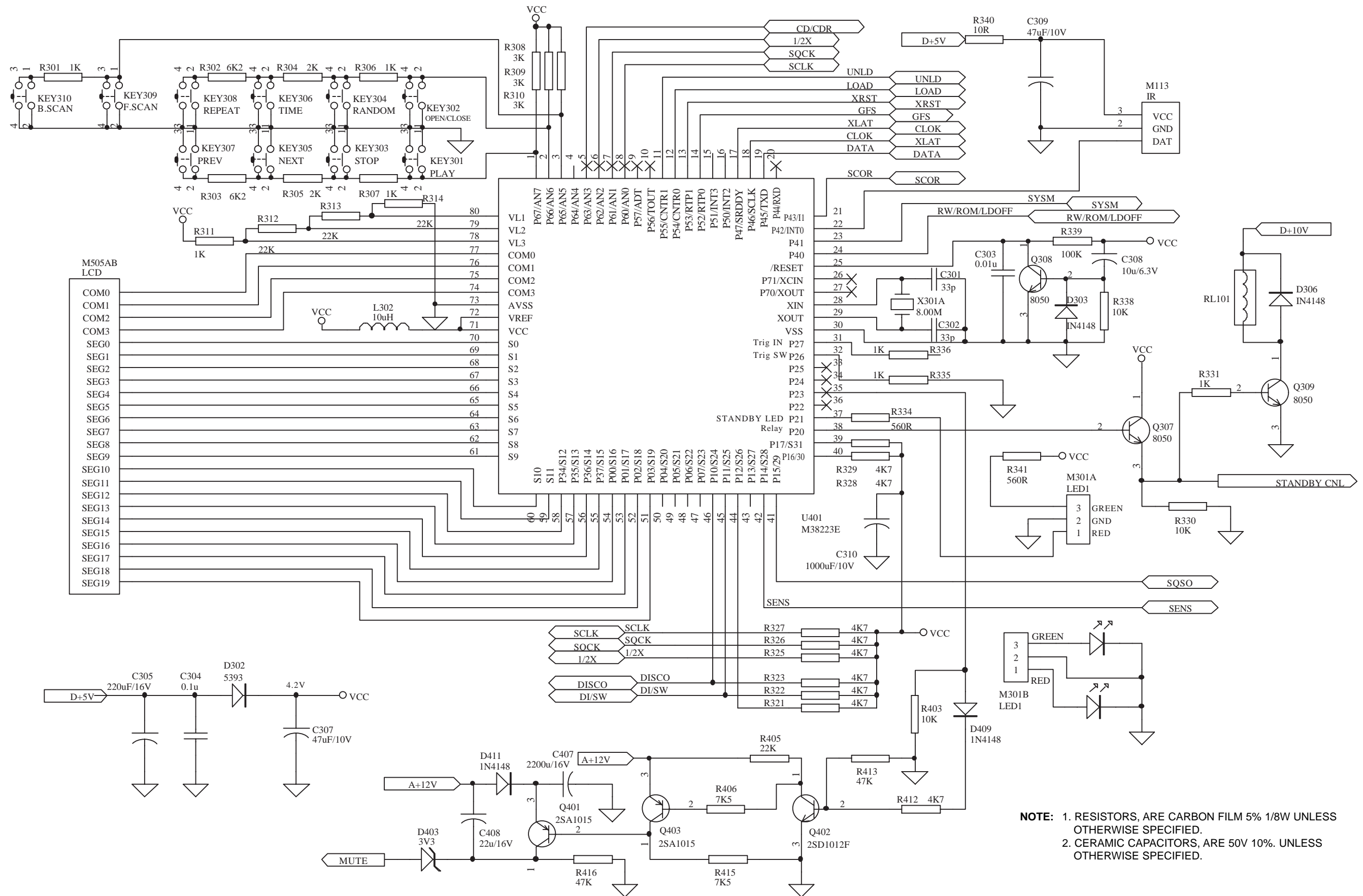

NOTE: 1. RESISTORS, ARE CARBON FILM 5% 1/8W UNLESS OTHERWISE SPECIFIED.
 2. CERAMIC CAPACITORS, ARE 50V 10%. UNLESS OTHERWISE SPECIFIED.

RF AMP

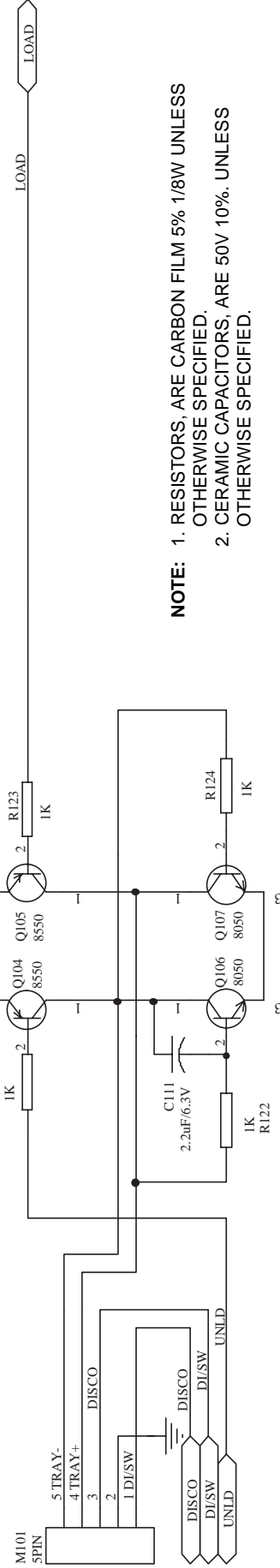
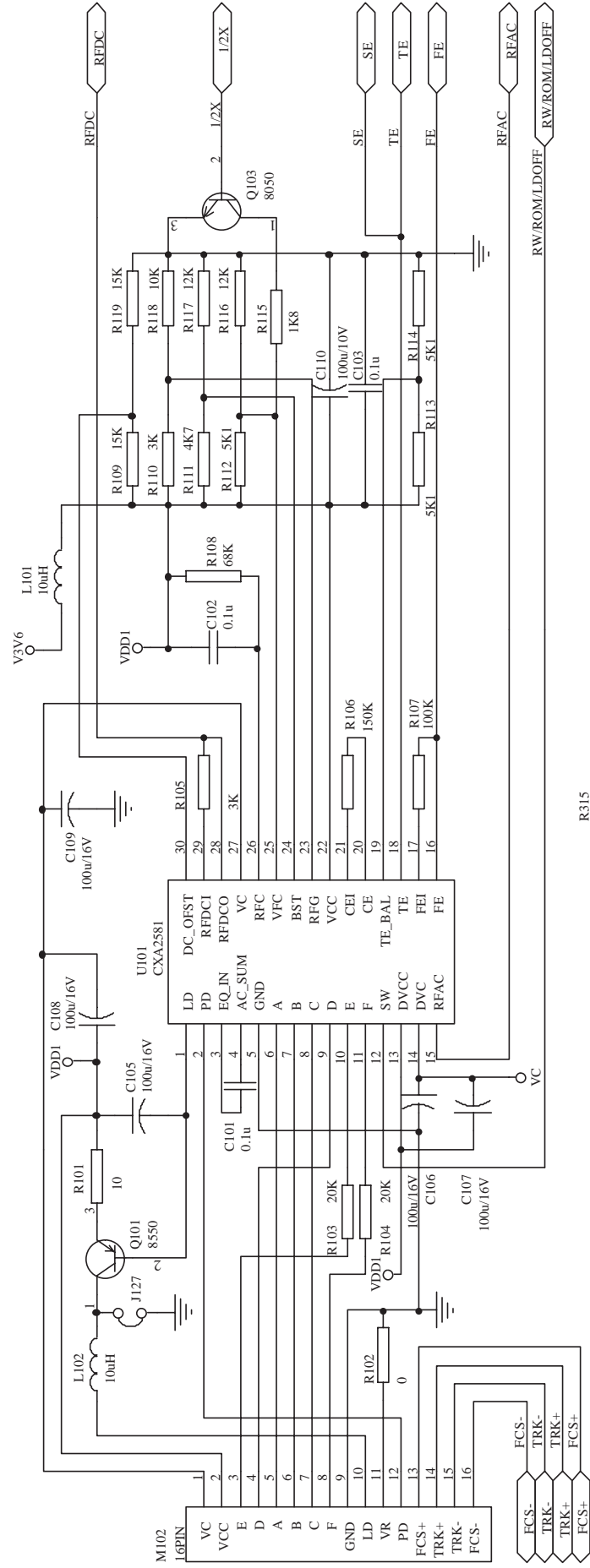

NOTE: 1. RESISTORS, ARE CARBON FILM 5% 1/8W UNLESS OTHERWISE SPECIFIED.
2. CERAMIC CAPACITORS, ARE 50V 10%. UNLESS OTHERWISE SPECIFIED.

AMP

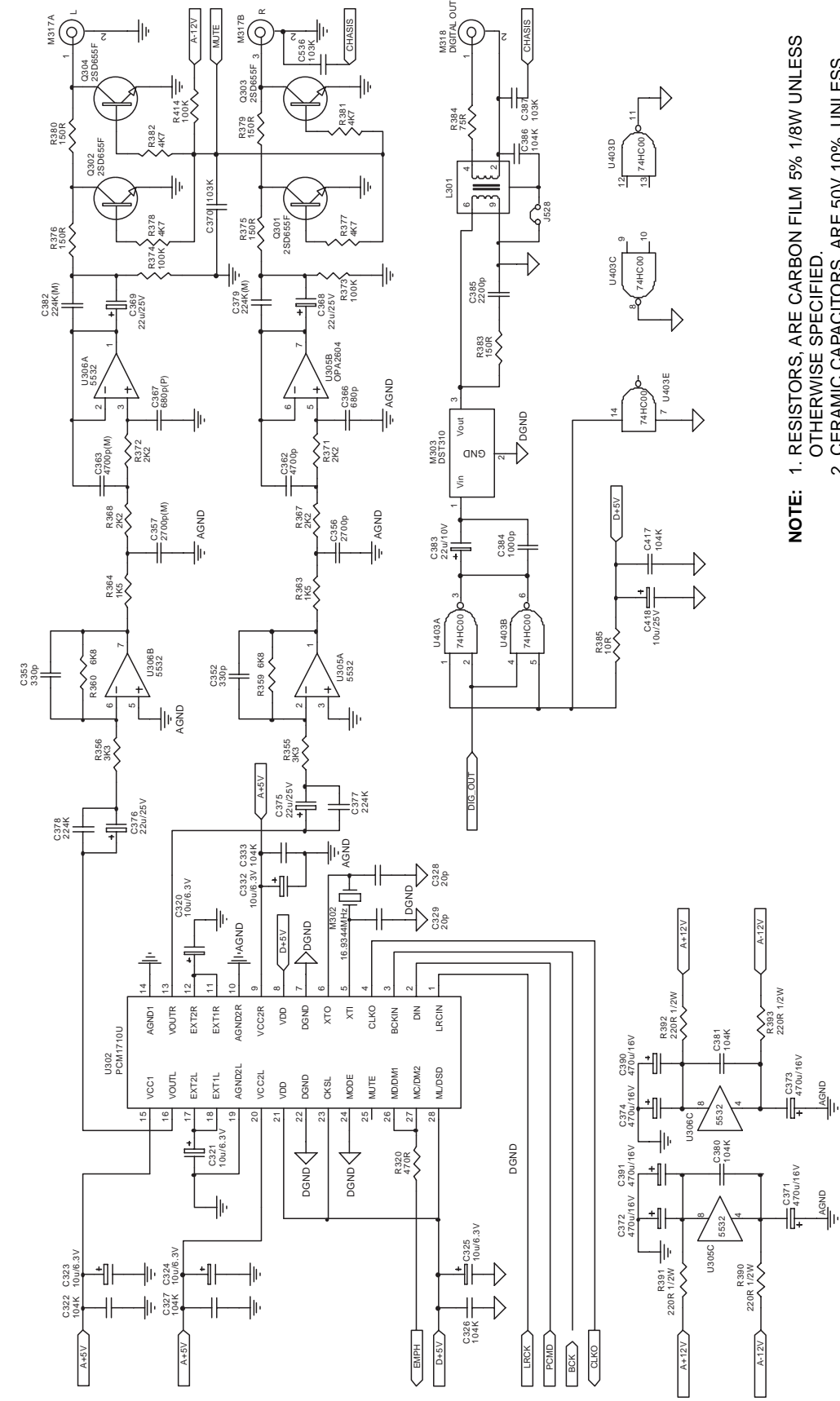

NOTE: 1. RESISTORS, ARE CARBON FILM 5% 1/8W UNLESS OTHERWISE SPECIFIED.
2. CERAMIC CAPACITORS, ARE 50V 10%. UNLESS OTHERWISE SPECIFIED.

IC BLOCK DIAGRAM

MAIN BOARD

U101: CXA2581N

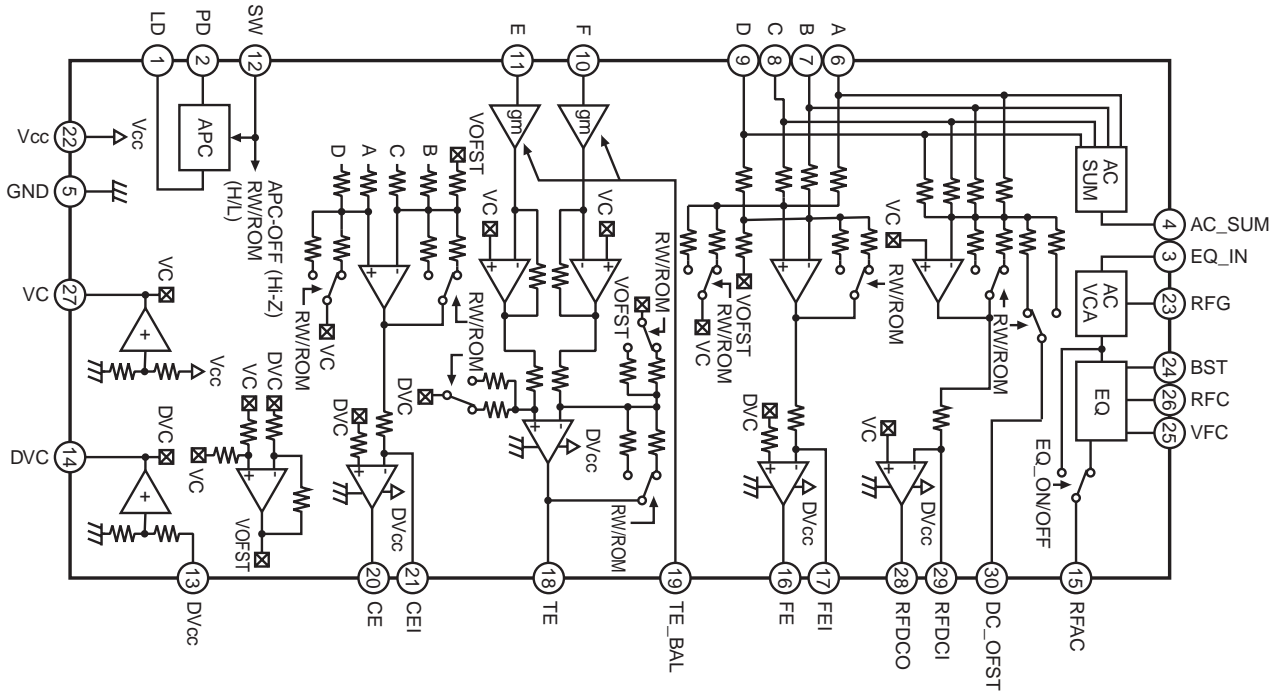

MAIN BOARD

U201: BA6392FP

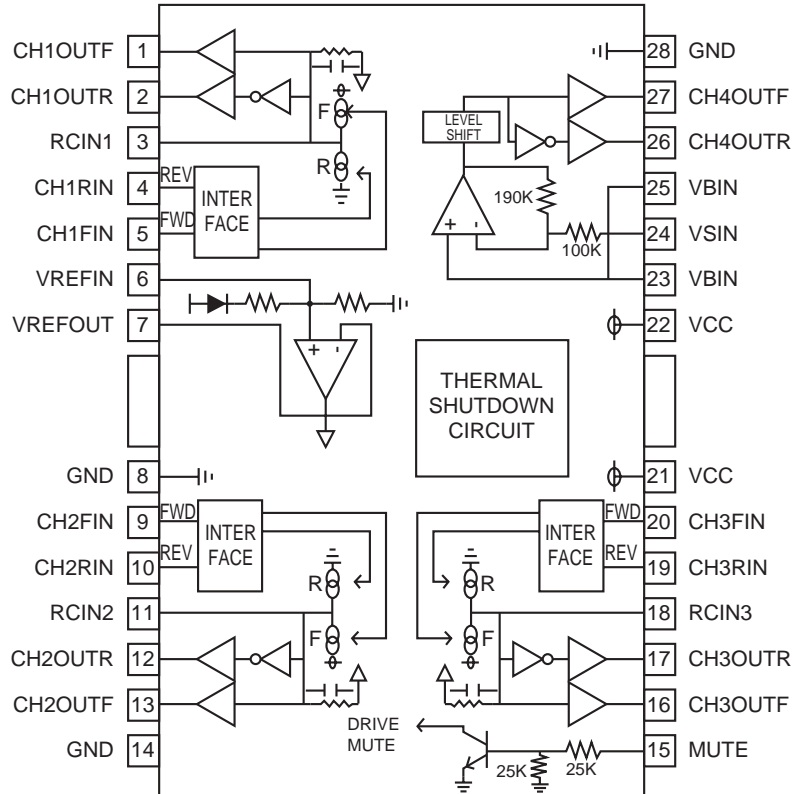

MAIN BOARD
U301: CXD3017Q

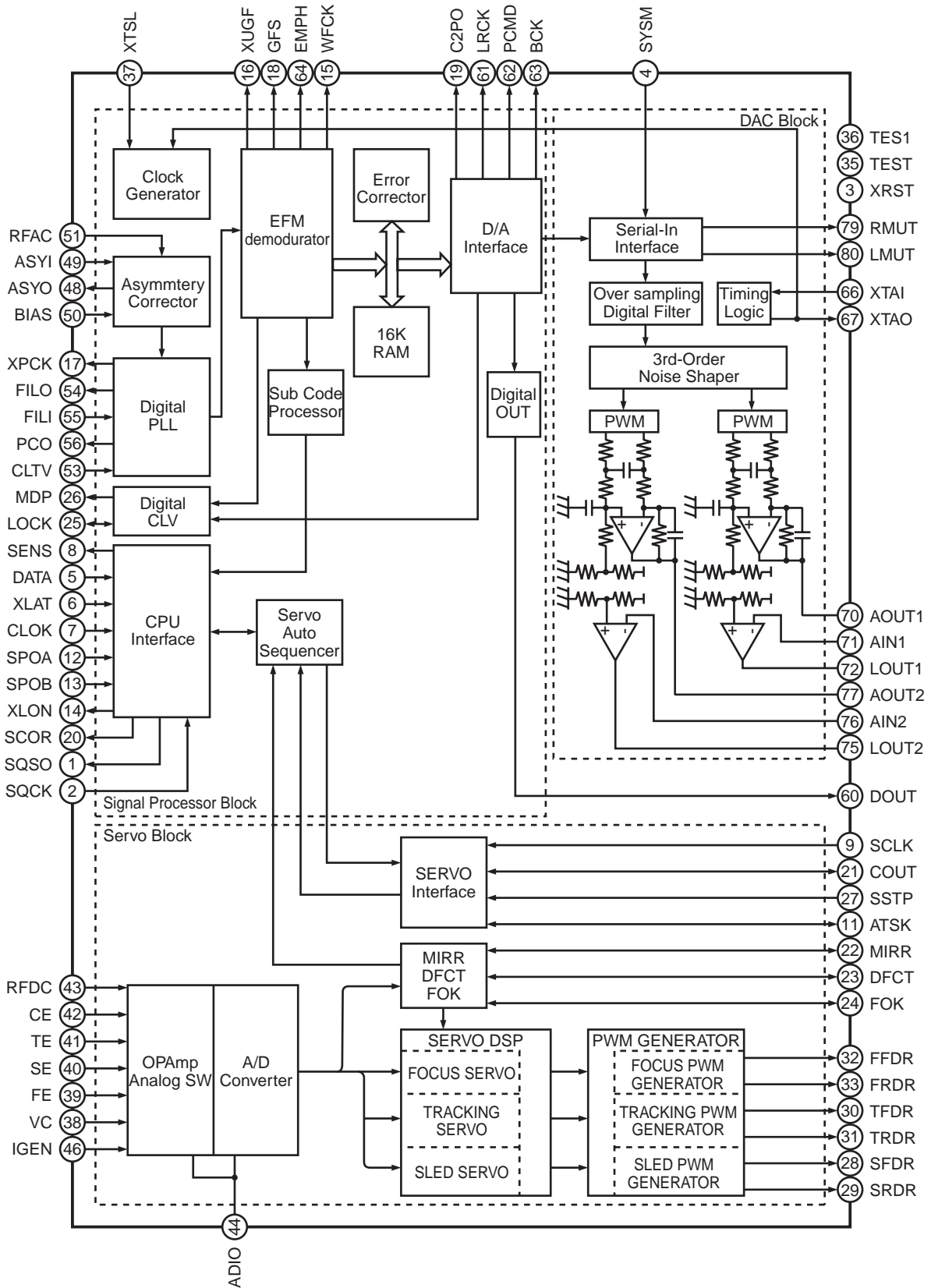

MAIN BOARD
U302: PCM1710U

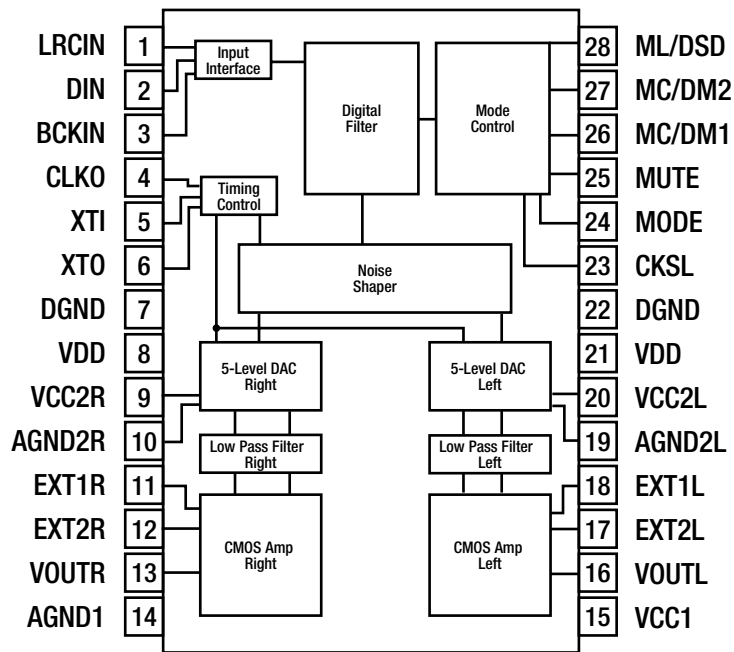

MAIN BOARD
U401: M38223E4HP4

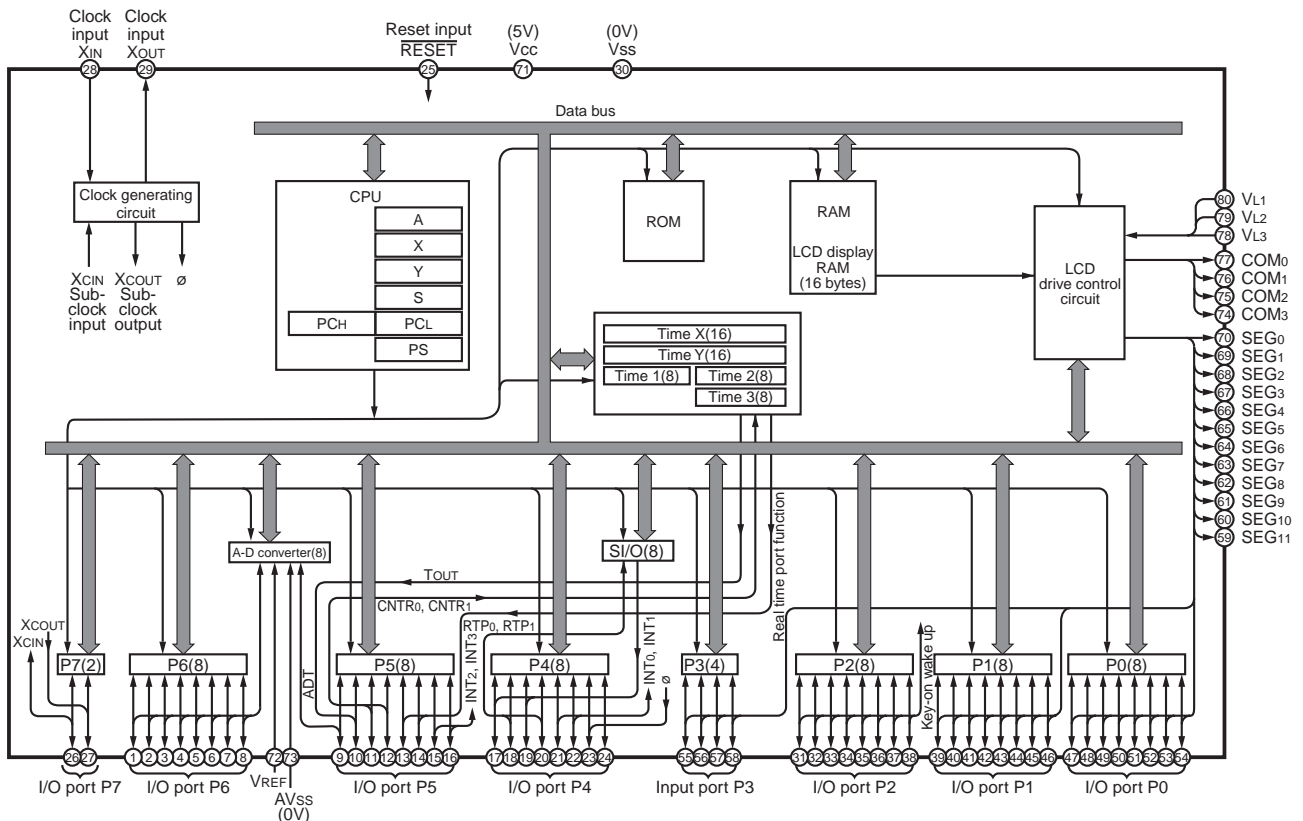

MAIN BOARD
U305, U306: NE5532

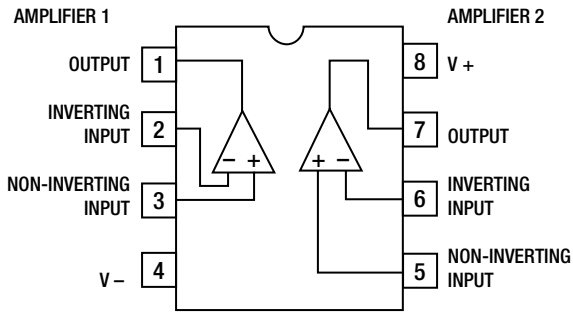

MAIN BOARD
U403: TC74HC00AP

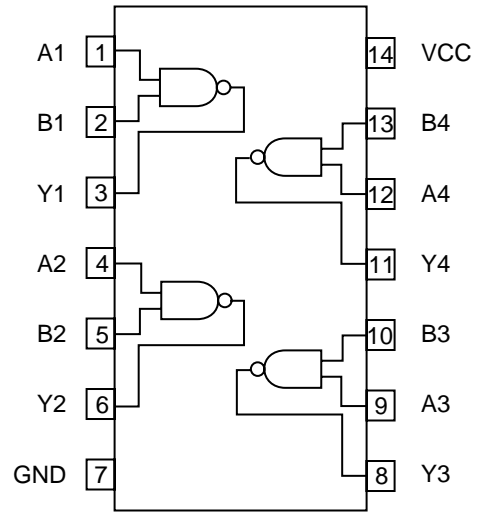

MAIN BOARD
U501, U502, U504,
U506, U507: 78XX

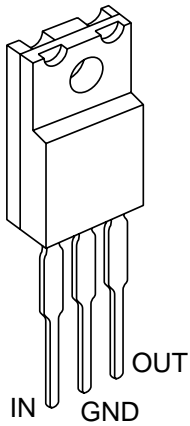

MAIN BOARD
U503: UPC79M12HF

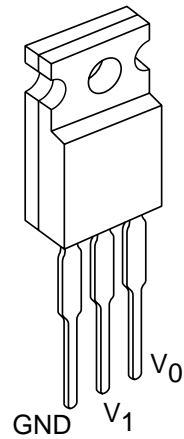

TROUBLESHOOTING GUIDE

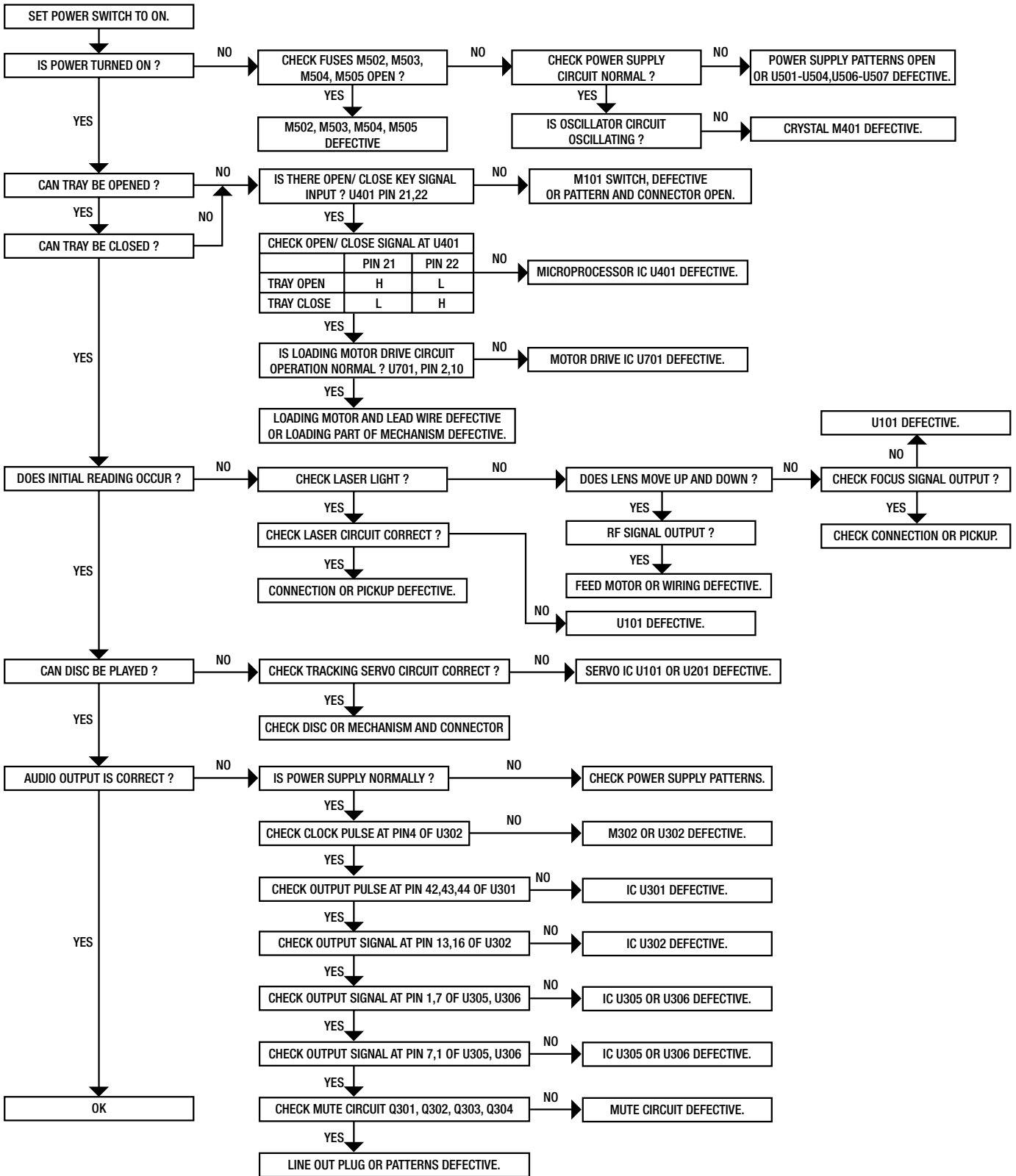

ELECTRICAL PARTS LIST

Reference No.	Part No.	Description
<u>DISPLAY ASSEMBLY</u> PCB BOARD 1000 *	PCB-N0A10C-DISP	DISPLAY ASSEMBLY
BACKLIGHT M502	2450-1146-0	EL BACKLIGHT
LCD M501	2460-1340-1	LCD DISPLAY (522)
IR SENSOR M113	4816-043T-3	IR SENSOR PIC-26043TM2
CONN ECTOR WIRES M505A, M505B M509A	7009-9630-0 7010-1300-1	CONN WIRE ASSY 14P 100MM CN ASSY SHIELD 2P P2.5
<u>KEYBOARD BOARD</u> PCB BOARD 2000 *	PCB-N0A10C-KEY	KEYBOARD ASSEMBLY
SWITCHES M101-M110	5200-3538-0	SWITCH, TACT SKHHBY 7MM
CONNECTOR WIRE M120C	7705-1120-2204	CONN ASSY 5P P2.5 L=120
RESISTORS R301,R306,R307 R302,R303 R304,R305	4711-102A-2 4711-622A-2 4711-202A-2	RMF 1/8W 1K 1% AT RMF 1/8W 6.2K 1% AT RMF 1/8W 2K 1% AT
<u>LED BOARD</u> PCB BOARD 6000 *	PCB-N0A10C-LED	LED ASSEMBLY
LED D304	3700-3517-RG	LED RED/GREEN (L-469HGW)
CONN WIRE M301B	7703-1280-2004	CONN.ASSY 3P P2.5 L=280
<u>LIVE ASSEMBLY</u> PCB BOARD 3000 *AH 3000 *C	PCB-N0A10C-LIVE PCB-N0A11C-LIVE	LIVE ASSEMBLY LIVE ASSEMBLY
CAPACITOR C800 	8910-0049-0	CAP400V 4700P DE7150F472MVA1KC

Reference No.	Part No.	Description
POWER SWITCH M802 △	5200-3151-0-01	POWER SWITCH
TRANSFORMER M810 *C △	1806-2170-0	EMI FILTER TLN12UA 150W3R0
TRANSFORMER ASSEMBLY 4000 *AH 4000 *C	PCB-N0A10C-PWR PCB-N0A11C-PWR	TRANSFORMER ASSEMBLY TRANSFORMER ASSEMBLY
TRANSFORMER M500 △	1806-2194-0	EI-57 TRANSFORMER 740 AC3
FUSE ASSEMBLY		
FUSES		
M502-M504 *AH △	5120-0020-0	FU T1A 250V UL/CSA 5x20MM
M502-M504 *C △	5120-0018-0	FU T1A 250V SEMKO/UDE 5x20MM
M505 *AH △	5120-0052-0	FUSE T1.6A 250V 5x20MM UL/CSA
M505 *C △	5120-0050-0	FUSE T1.6A 250V 5x20MM SEMKO/VDE
MAIN BOARD PCB BOARD 5000 *	PCB-N0A10C-MAIN	MAIN ASSEMBLY
CAPACITORS		
C101-C103	150F-104K-2-FC	CC 50V 0.1µF 10% AT 3.5x2
C105-C110	157D-107M-5-IU	CE 16V 100µF 20% RL 5x11
C111	157F-225M-5-IUNK	CE 50V 2.2µF 20% 5x11 NP
C201,C202,C204,C205	150F-221K-2-FC	CC 50V 220pF 10% AT 3.5x2
C203,C216,C221	150F-103K-2-FC	CC 50V 0.01µF 10% AT 3.5x2
C206	150F-331K-5-GE	CC 50V 330pF 10% RL 4x3
C207,C208	150F-104K-2-FC	CC 50V 0.1µF 10% AT 3.5x2
C209,C223	153F-152J-5-JM	CM 50V 1500PF 5% RL 5.8x7
C210,C213,C217,C222	150F-104K-2-FC	CC 50V 0.1µF 10% AT 3.5x2
C211,C212	15CH-270J-5-GG	CTC 0/60 27pF 5% RL 4x4
C214,C215	150F-471K-2-FC	CC 50V 470pF 10% AT 3.5x2
C218	150F-101K-2-FC	CC 50V 100pF 10% AT 3.5x2
C219,C220	150F-474M-5-II	CC 50V 0.47µF 20% RL 5X5
C226	157F-334K-5-IU	CE 50V 0.33µF 10% RL 5x11
C227,C228	150F-104K-2-FC	CC 50V 0.1µF 10% AT 3.5x2
C229	157D-477M-5-OY	CE 470µF +-20% RL 8X13
C230	157D-107M-5-IU	CE 16V 100µF 20% RL 5x11
C301,C302	15CH-330J-5-IG	CTC 0/60 33pF 5% RL 5x4
C303,C387	150F-103K-2-FC	CC 50V 0.01µF 10% AT 3.5x2
C304,C386	150F-104K-2-FC	CC 50V 0.1µF 10% AT 3.5x2
C305	157D-227M-5-OMK	CE 16V 220µF 20% RL 8x7
C307,C309	157C-476M-5-IU	CE 10V 47µF 20% RL 5x11
C308	157B-106M-5-EI	CE 6.3V 10µF 20% RL 3x5
C310	157C-108M-5-S5	CE 10V 1000µF 20% RL 10x16
C320,C321,	157B-106M-5-EI	CE 6.3V 10µF 20% RL 3x5
C322,C326,C327,C380,C381	150F-104K-5-II	CC 50V 0.1µF 10% RL 5x5
C323-C325,C332,C334	157B-106M-5-EI	CE 6.3V 10µF 20% RL 3x5
C328,C329	15CH-200J-5-GG	CTC 0/60 20pF 5% RL 4x4

Reference No.	Part No.	Description
C330,C370	153F-103J-5-IM	CM 50V 0.01 μ F 5% RL 5X7
C331	157C-226M-5-IUK	CE 10V 22 μ F 20% RL 5X11
C352,C353	150F-331K-5-GE	CC 50V 330pF 10% RL 4x3
C356,C357	153F-272J-5-JM	CM 50V 2700PF 5% RL 5.5x7
C362,C363	153F-472J-5-KM	CM 50V 4700pF 5% RL 6x7
C366,C367	158F-681J-5-KW	CP 50V 680pF 5% RL 6x12
C368,C369,C375,C376	157E-226K-5-IU	CE 25V 22 μ F 10% RL 5x11
C371-C374	157D-477M-5-OY	CE 470 μ F +-20% RL 8X13
C377-C379,C382	153F-224J-5-MIB	CM 50V 0.22 μ F 5% RL 7x5
C383	157C-226M-5-IU	CE 10V 22 μ F 20% RL 5x11
C384	150F-102K-2-FC	CC 50V 1000pF 10% AT 3.5x2
C385	150F-222K-2-GD	CC 50V 0.0022 μ F 10% AT
C390,C391	157D-477M-5-OY	CE 470 μ F +-20% RL 8X13
C407	157D-228M-5-X9E	CE 16V 2200 μ F 20% RL 12.5x20
C408	157E-226M-5-IU	CE 25V 22 μ F 20% RL 5x11
C417	150F-104K-5-II	CC 50V 0.1 μ F 10% RL 5x5
C418	157E-106M-5-IU	CE 25V 10 μ F 20% RL 5x11
C501-C505,C526,C528,C531,C532	150F-104K-5-II	CC 50V 0.1 μ F 10% RL 5x5
C506,C507	157E-228M-5-X9	CE 25V 2200 μ F 20% RL 12.5x20
C508,C525,C536	157C-108M-5-S5	CE 10V 1000 μ F 20% RL 10x16
C511	157C-227M-5-KW	CE 10V 220 μ F 20% RL 6x12
C512,C513	157D-108M-5-S9	CE 16V 1000 μ F 20% RL 10x20
C518	157E-107M-5-KW	CE 25V 100 μ F 20% RL 6x12
C521	150F-104K-2-FC	CC 50V 0.1 μ F 10% AT 3.5x2
C522	157D-107M-5-IU	CE 16V 100 μ F 20% RL 5x11
C523	157F-225M-5-IU	CE 50V 2.2 μ F 20% RL 5x11
C524	153F-223K-5-LQ	CM 50V 0.022 μ F 10% RL 6.5x9
C527,C533	157C-477M-5-OW	CE 10V 470 μ F 20% RL 8x12
C529	157D-338M-5-W@	CE 16V 3300 μ F 20% RL 12x26
C530	157E-106M-5-IU	CE 25V 10 μ F 20% RL 5x11
C534,C535,C537,C540-C543	150F-104K-5-II	CC 50V 0.1 μ F 10% RL 5x5
C710	157B-107M-5-KM	CE 6.3V 100 μ F 20% RL 6x7
Q106B	157F-225M-5-IUNK	CE 50V 2.2 μ F 20% RL 5X11
DIODES		
D201	4804-0010-2	DIODE 1N4001 AT
D301,D303,D306	4804-1480-2	DIODE 1N4148 AT
D302	4805-3930-2	DIODE 1N5393 200V 1.5A
D403	4837-3V31-2	DZ 1/2W 3.1-3.5V ROHM AT
	4837-3A31-2	DZ 1/2W 3.16~3.38V ROHM
D409,D411	4804-1480-2	DIODE 1N4148 AT
D501-D504,D506,D514-D517	4804-0010-2	DIODE 1N4001 AT
D505	4840-1140-0	ZD 1.3W 3.3V 5% AT
D507,D508	4804-0010-2	DIODE 1N4001 AT
D513	4805-3930-2	DIODE 1N5393 200V 1.5A
COILS		
L101,L102,L302	1801-100K-M	COIL 10 μ H 10% BL7.0
L201	1801-270K-M	COIL 27 μ H,10%,AL,BL7.6
L301	1802-0450-0	DIGITAL COIL
WAFER / JACKS		
M102	2101-1382-0	CONNECTOR FLEXIBLE 16P P=1.0mm
M120	2102-051S-004	5P ST.WAFER P=2.5mm
M301A	2102-031S-004	3 PIN ST. WAFER P=2.5mm

<u>Reference No.</u>	<u>Part No.</u>	<u>Description</u>
M317	2113-1300-0	2P RCA JACK W/R AU
M318	2113-1170-0	1P RCA JACK YL AU
M500A	2102-071S-004	WF T8 DE 7PIN COULOMB
M505A,M505B	2102-141S-004	14P ST. WAFER P=2.5mm
M509	2102-021S-004	2P ST.WAFER P=2.5mm
M509A	2102-022S-008	WAFER 2PIN PITCH=2.54MM
CRYSTALS		
M302	2300-0110-0	CRYSTAL 16.9344 MHZ
X301	2300-1420-0	CRYSTAL 8MHZ
FILTER		
M303	2704-0060-0	EMC FILTER
TRANSISTORS		
Q101,Q104,Q105	4860-0060-5	TR SS8550 C/D SAMSUNG RL
Q103,Q106,Q107	4860-0050-5	TR SS8050 C/D SAMSUNG RL
Q301-Q304	4860-1780-5	TR 2SD655F HFE:600-1200
Q305,Q307-Q309	4860-0050-5	TR SS8050 C/D SAMSUNG RL
Q312,Q313	4860-0060-5	TR SS8550 C/D SAMSUNG RL
Q401,Q403	4860-0660-5	TR 2SA1015 (G.R.) RL
Q402	4851-012F-5	TR 2SD1012F/G HFE: 160-560
Q520	4860-0050-5	TR SS8050 C/D SAMSUNG RL
RELAYS		
RL101	4500-0200-1	RELAY 2P2T BT-12S 12VDC
R709	4756-4716-3-06	SVR 470 H3 7X7.6 RH0615C
RESISTORS		
R101	4701-100J-C	RCF 1/8W 10R 5% ATS
R103,R104	4701-203J-C	RCF 1/8W 20K 5% ATS
R105,R110	4701-302J-2	RCF 1/8W 3K 5% AT
R106	4701-154J-C	RCF 1/8W 150K 5% ATS
R107	4701-104J-C	RCF 1/8W 100K 5% ATS
R108	4701-683J-C	RCF 1/8W 68K 5% ATS
R109,R119	4711-153A-2	RMF 1/8W 15K 1% AT
R111	4701-472J-C	RCF 1/8W 4.7K 5% ATS
R112-R114	4701-512J-C	RCF 1/8W 5.1K 5% ATS
R115	4701-182J-C	RCF 1/8W 1.8K 5% ATS
R116,R117	4701-123J-C	RCF 1/8W 12K 5% ATS
R118	4701-103J-C	RCF 1/8W 10K 5% ATS
R121-R124	4701-102J-C	RCF 1/8W 1K 5% ATS
R201	4701-472J-C	RCF 1/8W 4.7K 5% ATS
R202-R211	4701-102J-C	RCF 1/8W 1K 5% ATS
R212,R220,R225	4701-104J-C	RCF 1/8W 100K 5% ATS
R213,R224,R230,	4701-103J-C	RCF 1/8W 10K 5% ATS
R214	4701-822J-C	RCF 1/8W 8.2K 5% ATS
R215,R315	4701-4R7J-C	RCF 1/8W 4.7R 5% ATS
R217	4701-102J-C	RCF 1/8W 1K 5% ATS
R218,R219	4701-153J-C	RCF 1/8W 15K 5% ATS
R223	4701-333J-C	RCF 1/8W 33K 5% ATS
R226	4701-105J-C	RCF 1/8W 1M 5% ATS
R227	4701-101J-C	RCF 1/8W 100R 5% ATS
R228,R229	4701-332J-C	RCF 1/8W 3.3K 5% ATS
R308-R310	4701-302J-2	RCF 1/8W 3K 5% AT

<u>Reference No.</u>	<u>Part No.</u>	<u>Description</u>
R311,R331,R335,R347	4701-102J-C	RCF 1/8W 1K 5% ATS
R312-R314	4701-223J-C	RCF 1/8W 22K 5% ATS
R317	4711-362A-2	RMF 1/8W 3.6K 1% AT
R318,R330,R338,R346	4701-103J-C	RCF 1/8W 10K 5% ATS
R320	4701-471J-C	RCF 1/8W 470R 5% ATS
R321-R323	4701-472J-C	RCF 1/8W 4.7K 5% ATS
R325-R329,R377,R378	4701-472J-C	RCF 1/8W 4.7K 5% ATS
R334,R341	4701-561J-C	RCF 1/8W 560R 5% ATS
R339,R373,R374	4701-104J-C	RCF 1/8W 100K 5% ATS
R340	4701-100J-C	RCF 1/8W 10R 5% ATS
R354,R357	4701-271J-C	RCF 1/8W 270R 5% ATS
R355,R356	4711-332A-2	RMF 1/8W 3.3K 1% AT
R359,R360	4701-682J-C	RCF 1/8W 6.8K 5% ATS
R363,R364	4701-152J-C	RCF 1/8W 1.5K 5% ATS
R367,R368,371,R372	4701-222J-C	RCF 1/8W 2.2K 5% ATS
R375,R376,R379,R380,R383,R521	4701-151J-C	RCF 1/8W 150R 5% ATS
R381,R382	4701-472J-C	RCF 1/8W 4.7K 5% ATS
R384	4701-750J-C	RCF 1/8W 75R 5% ATS
R390-R393	4717-221J-C	RMF 1/2W 220R 5% ATS
R403	4701-103J-C	RCF 1/8W 10K 5% ATS
R405	4701-223J-C	RCF 1/8W 22K 5% ATS
R406,R415	4701-752J-C	RCF 1/8W 7.5K 5% ATS
R412	4701-472J-C	RCF 1/8W 4.7K 5% ATS
R413,R416	4701-473J-C	RCF 1/8W 47K 5% ATS
R414	4701-104J-C	RCF 1/8W 100K 5% ATS
R501	4711-273A-C	RMF 1/8W 27K 1% ATS
R502	4701-183J-C	RCF 1/8W 18K 5% ATS
R520	4701-513J-C	RCF 1/8W 51K 5% ATS
ICS		
U101	3131-8030-0	IC CXA2581N ASP FOR CD
U201	3131-8040-0	IC BA6392FP 4-CHANNEL BTL
U301	3131-8000-0	IC CXD3017Q DSP FOR CD
U302	3130-5660-0	IC PCM1710U D/A CONVERTER
U305,U306	3130-2430-0	IC-NE5532 OPER. AMP PHILIP
U401	3131-8020-0	IC M38223E4HP4 MICRO OTP
	3131-8020-1	IC M38223E4HP4 MICRO MASK
U403	3130-4160-0	IC TC74HC00AP DIGITAL
U501,U506	3130-2020-3	IC 7805 REG 5V 1.5A
U502	3130-2520-3	IC 7812 12V REGULATOR
U503	3130-3800-0	IC UPC79M12HF REGULATOR
U504	3130-9030-0	IC NJM78L09A 9V 0.1A
U507	3130-2790-1	IC NJM7808FA +8V REG

- NOTE:**
- The components identified by \triangle mark are critical for risk of fire and electrical shock. Replace only with part number specified.
 - <*AH > : USA, Canadian model only.
 - <*C > : European model only.
 - Capacitors : CP-Polystyrene, CM-Mylar, CE-Electrolytic, CC-Ceramic, CTC-NPO.
 - Resistors : RMF-Metal Film, RCF-Carbon Film, RWR-Wirewound Metal Oxide.

MECHANISM EXPLODED VIEW

WSL-2130CCM

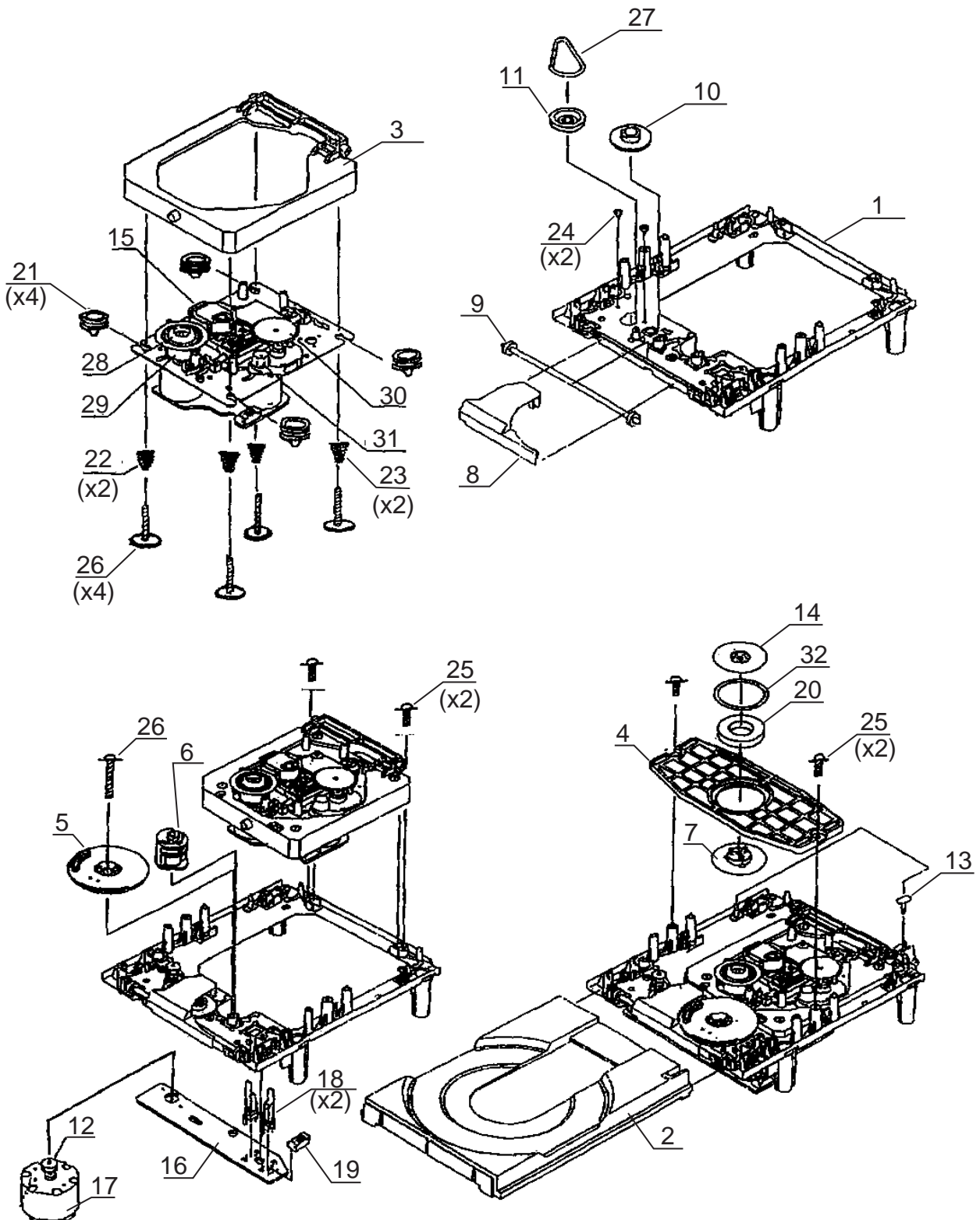

MECHANISM EXPLODED VIEW PARTS LIST

<u>Item</u>	<u>Part No.</u>	<u>Description</u>	<u>Qty</u>
1	4102-9000-0	Outside Main Chassis	1
2	4102-9001-0	Tray	1
3	4102-9002-0	Subchassis	1
4	4102-9003-0	Chucking Plate	1
5	4102-9004-0	Drive Gear	1
6	4102-9005-0	Control Cam	1
7	4102-9006-0	Chucking Pulley	1
8	4102-9007-0	Gear Cover	1
9	4102-9008-0	Tray Gear	1
10	4102-9009-0	Intermediate Gear	1
11	4102-9010-0	Loading Pulley	1
12	4102-9011-0	Motor Pulley	1
13	4102-9012-0	SW Pin	1
14	4102-9013-0	Chucking Yoke	1
15	4102-9014-0	Optical Pickup Unit	1
16	4102-9015-0	Loading PWB	1
17	4102-9016-0	Motor RF-500TB-14415	1
18	4102-9017-0	Leaf Switch	1
19	4102-9018-0	Connector pin (5P)	1
20	4102-9019-0	Magnet	1
21	4102-9020-0	Insulator	4
22	4102-9021-0	Coil Spring (Front)	2
23	4102-9022-0	Coil Spring (Rear)	2
24	4102-9023-0	Screw-Motor M2.6x2.5	2
25	4102-9024-0	Screw M2.6x7	2
26	4102-9025-0	Screw Washer Based M2.6x16	4
27	4102-9026-0	Rubber Belt	1
28	4102-9027-0	Center Ring	1
29	4102-9028-0	Turn Table	1
30	4102-9029-0	Gear (A)	1
31	4102-9030-0	Motor Gear	1
32	4102-9031-0	Damper	1

EXPLODED VIEW

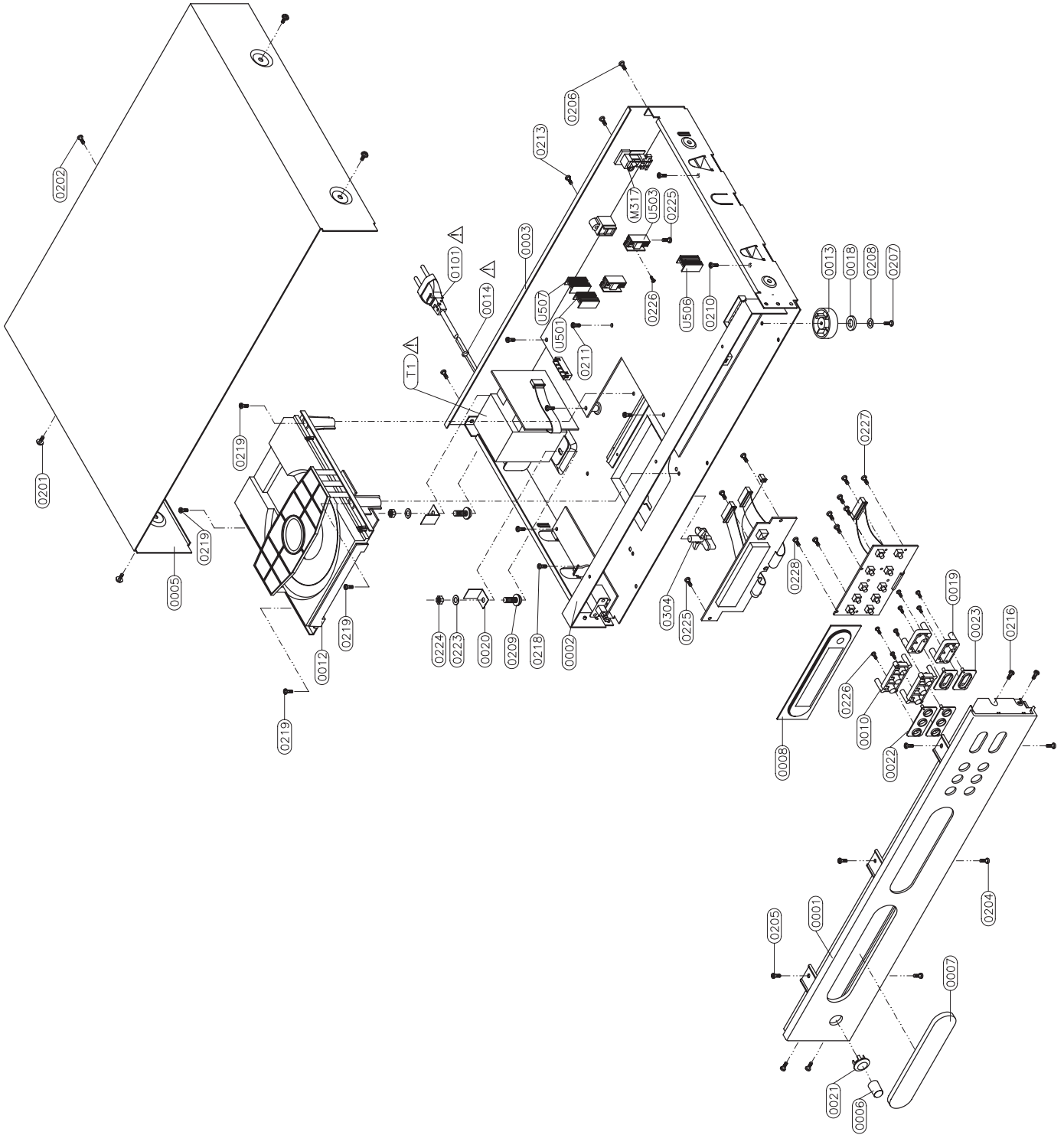

EXPLODED VIEW PARTS LIST

<u>Item</u>	<u>Part No.</u>	<u>Description</u>	<u>Qty</u>
0001	1465-5705-3	FASSCIA W/SS PAINT	1
0002	1402-3781-2	STARP	1
0003*AH	1402-3520-0	CHASSIS W/SS PAINT	1
0003*C	1402-3521-0	CHASSIS W/SS PAINT	1
0005	1402-3530-0	COVER	1
0006	2442-1000-0	POWER BUTTON	1
0007	4154-4191-0	CD DOOR W/SS PAINT	1
0008	3716-4313-0	WINDOW LENS W/SS	1
0010	2444-1201-0	BUTTON TRIO	2
0012	4111-1051-0	CD DECK	1
0013	4152-4631-0	RUBBER FOOT 14MM HIGH	4
0014 \triangle	4151-9461-0	STRAIN RELIEF BUSHING 4N-4	1
0018	4152-4641-0	CUSHION FOOT	4
0019	2444-1301-1	BUTTON RACKER	2
0020	4132-6191-0	BRACKET,MTG,X'FORMER	2
0021	4152-4331-0	POWER BUTTON BEZEL	1
0022	4154-0031-0	BEZEL TRIO	2
0023	4154-0091-0	BEZEL RACKER	2
0101*AH \triangle	7009-3100-2	AC CORD 18AWGX2 SPT-2 D.INSULATED UL/CSA	1
0101*C \triangle	7009-3110-0	AC CORD SEMKO	1
0201	2900-4006-3010	M4X0.5PX6MM W/FLAT WASHER	4
0202	2954-3008-3000	T3X8MM SELF TAPPING	12
0205	2954-3008-0000	TAPPING 3X8MM B-TITE(YEL.ZN)	17
0208	2842-3367-0	METAL WASHER ID=3.3 OD=6.7	4
0209	2900-4010-3030	PH W/WASHER M4X10 BL ZN	2
0211	2904-3006-0000	SCREW M3X8	4
0218	2954-3006-0000	3X6MM B-TITE (YEL.ZN)	2
0219	2904-3008-3000	SCREW M3X6	4
0223	2600-4008-0973	FLAT WASHER M4X0.8X9.7 BZ	2
0224	2640-4030-0703	M4 NUT (BLK)	2
0226	2954-2006-0000	TAPPING SCREW 2X6	13
0227	2954-2608-0000	SCREW BT 2.6X8	7
0228	2950-2608-3000	SCREW PAN HEAD,B-TITE 2.6X8 BLACK	1
0304	1463-160B-0	CD RANSIT LOCK (RED)	1
0320	4154-1931-0	DUST PROOF CUSHION	1
T1 \triangle	1806-2194-0	EI-57 TRANSFORMER 740 AC3	1
U501-U503	5400-9130-0	HEAT SINK FOR 7805 2438-17	3
U506-U507	5400-9130-0	HEAT SINK FOR 7805 2438-17	2

- NOTE:**
- The components identified by \triangle mark are critical for risk of fire and electrical shock. Replace only with part number specified.
 - <*AH > : USA, Canadian model only.
 - <*C > : European model only.

PACKING DIAGRAM

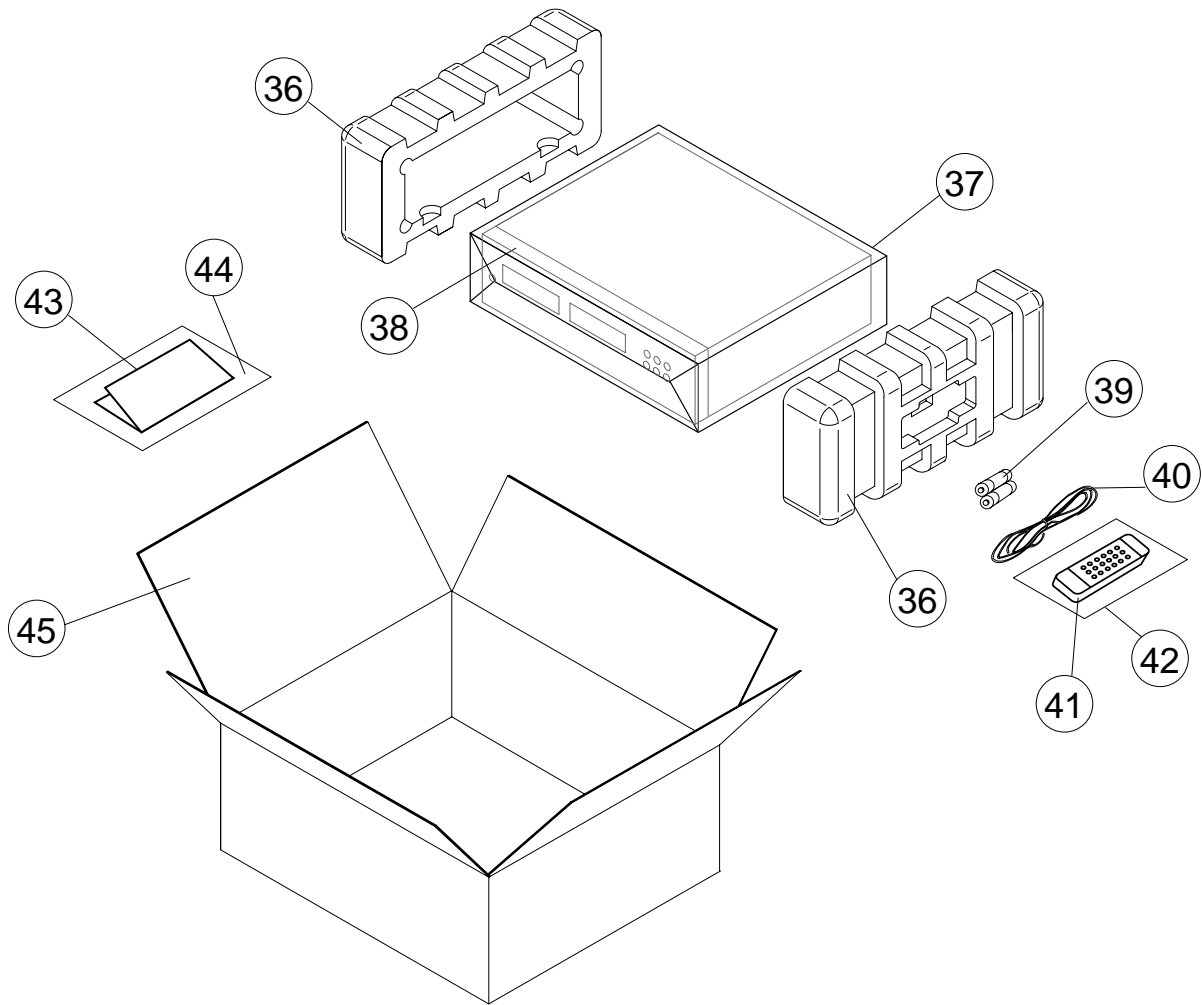

ITEM	PART NO.	DESCRIPTION	Q'TY
36	1490-3783-1	POLYFOAM ENDCAP	2
37	1497-1332-1	UNIT POLYBAG	1
38	1497-1432-0	FASCIA COVER	1
39	4060-0530-0	BATTERIES	2
40	2103-7302-1	RCA CABLE	1
41	8912-0005-0	REMOTE CONTROL HANDDSET	1
42	1497-1302-0	REMOTE CONTROL POLYBAG	1
43	4301-4165-0	INSTRUCTION MANUAL	1
44	1497-1062-0	MANUAL POLYBAG	1
45	1435-8300-0-2	CARTON BOX	1

Proprietary information for servicing purposes only. The information herein may not be used commercially without the prior written agreement of NAD Electronics International, Toronto, Canada.

SERVICE MANUAL

C 521i

COMPACT
DISC PLAYER

© NAD 2002

NAD ELECTRONICS INTERNATIONAL
TORONTO