

# SERVICE MANUAL

**NAD**

**C 320**

**STEREO  
INTEGRATED  
AMPLIFIER**

**C 320**

**STEREO  
INTEGRATED  
AMPLIFIER**

# TABLE OF CONTENTS

DESCRIPTION	PAGE
REAR PANEL/FRONT PANEL VIEW.....	3
SPECIFICATIONS.....	4-5
DISASSEMBLY INSTRUCTIONS.....	6
ALIGNMENT PROCEDURE.....	7
PCB LAYOUT.....	8-9
SCHEMATIC DIAGRAM.....	10-13
IC BLOCK DIAGRAM.....	14
WIRING DIAGRAM.....	15
ELECTRICAL PARTS LIST.....	16-18
EXPLODED VIEW PARTS LIST.....	19
EXPLODED VIEW.....	20
PACKING DIAGRAM.....	21

## SERVICE SAFETY PRECAUTIONS

### 1. Replacing the fuses

CAUTION: FOR CONTINUED PROTECTION AGAINST THE RISK OF FIRE, REPLACE ONLY WITH DESIGNATED TYPE OF FUSE FOR \*AH, \*B1, \*B AND \*C VERSIONS.

Reference No	Part Number	Description
F41—F44	20-00630-25	T6.3AL250V Fuse

#### NOTE:

- <\*AH> : USA, CANADIAN MODEL ONLY.
- <\*B> : UK MODEL ONLY.
- <\*B1> : AUSTRALIAN MODEL ONLY.
- <\*C> : EUROPEAN MODEL ONLY.

### 2. Safety check out

(Only U.S.A. Model)

Before returning the product to the customer, make leakage current or resistance measurements to determine that exposed parts are acceptably insulated from the supply circuit.

Parts marked with the symbol  are critical with regard to the risk of fire and electric shock. Replace only with parts recommended by the manufacturer.

# REAR PANEL/FRONT PANEL VIEW

## REAR PANEL

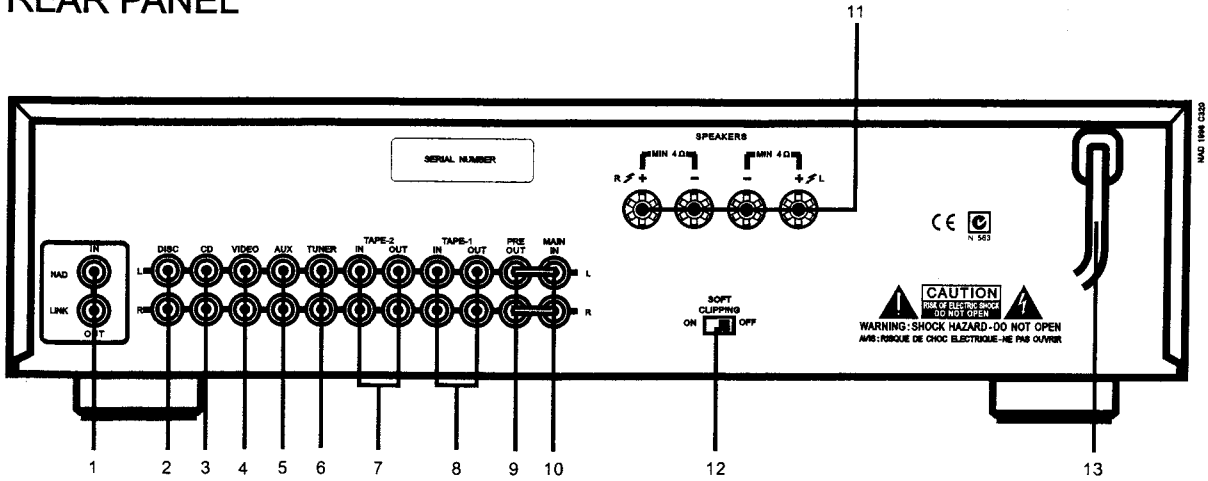

- |                     |                   |
|---------------------|-------------------|
| 1. NAD Link In, Out | 8. Tape 1 In, Out |
| 2. Disc Input       | 9. Pre Out        |
| 3. CD Input         | 10. Main In       |
| 4. Video Input      | 11. Speakers      |
| 5. AUX Input        | 12. Soft Clipping |
| 6. Tuner Input      | 13. AC Line Cord  |
| 7. Tape 2 In, Out   |                   |

## FRONT PANEL

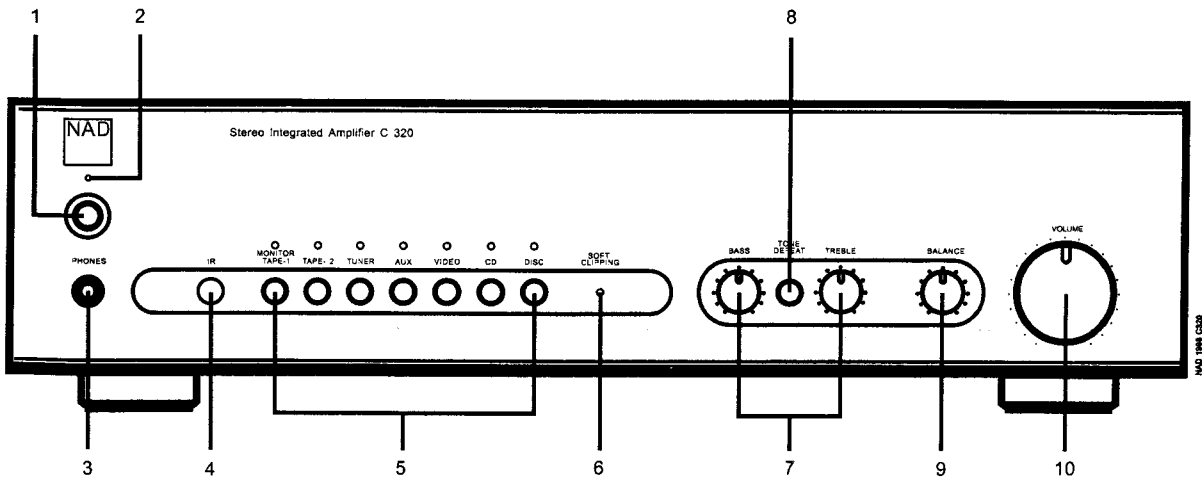

- |  |                            |
|--|----------------------------|
| 1. Power   | 6. Soft Clipping Indicator |
| 2. Power/Protection LED  | 7. Bass&Treble Controls    |
| 3. Head Phone Socket   | 8. Tone Defeat             |
| 4. Infra-red Receiver  | 9. Balance                 |
| 5. Input Selectors (Disc, CD, Video, AUX, Tuner, Tape 2, Tape 1 Monitor) | 10. Volume                 |

## REMOTE CONTROL

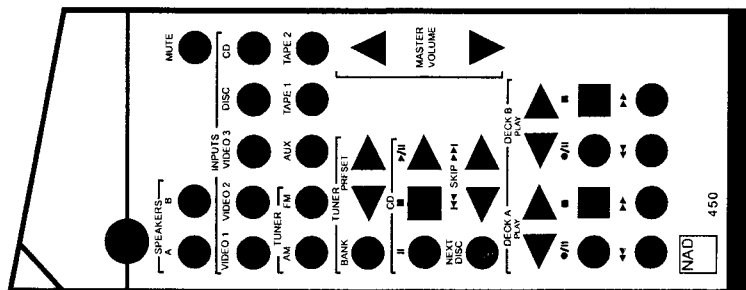

# SPECIFICATIONS

## POWER AMPLIFIER SECTION STEREO MODE

<b>CONTINUOUS AVERAGE POWER OUTPUT INTO 8 OHMS OR 4 OHMS</b> (Min. power per channel, 20 Hz – 20 kHz, with no more than rated distortion)	<b>40 W (16 dBW)</b>
Rated Distortion (THD 20 Hz – 20 kHz)	<b>0.03%</b>
Clipping power (maximum continuous power per channel).	<b>70 W</b>
IHF dynamic headroom at 8 ohms	<b>+ 3.5 dB</b>
IHF dynamic power (maximum short term power per channel)	
8 ohms:	<b>90 W (19.5 dBW)</b>
4 ohms:	<b>120 W (21 dBW)</b>
2 ohms:	<b>160 W (22 dBW)</b>
Damping factor (ref. 8 ohms 1 kHz)	<b>&gt; 100</b>
Input Impedance	<b>R = 20 kohms C = 470 pF</b>
Input sensitivity (for rated output into 8 ohms)	<b>1.1 V</b>
Voltage gain	<b>16 (24dB)</b>
Frequency response 20 Hz – 20 kHz	<b>±0.2dB</b>
Signal / Noise ratio, A-weighted	<b>105 dB ref. 1 W 121 dB ref. 40 W</b>
THD + Noise (Total Harmonic Distortion, 20 Hz – 20 kHz, from 250 mW to rated output)	<b>&lt; 0.03%</b>
SMPTE I.M. (Intermodulation Distortion, 60 Hz + 7 kHz, 4:1, from 250 mW to rated output)	<b>&lt; 0.03%</b>
IHF I.M. (CCIF IM Distortion, 19 + 20 kHz at rated output)	<b>&lt; 0.03%</b>
Headphones Output Impedance	<b>220 ohms</b>

## **PREAMPLIFIER SECTION**

### **LINE LEVEL INPUTS**

(Disk, CD, Video, Auxiliary, Tuner, Tape 1, Tape 2)

Input impedance (R and C)	<b>50 kohms + 320 pF</b>
Input sensitivity (ref. rated power)	<b>215 mV</b>
Maximum input signal	<b>4.5 V</b>
Signal / Noise ratio, A-weighted (from CD Input to Speakers Output, Volume Setting for 500mV in , 8ohms 1W out)	<b>99.5 dB ref. 1W</b>
Frequency response, 20 Hz – 20 kHz	<b>0.3 dB (tone defeat on) 0.5 dB (tone defeat off)</b>
THD + Noise, SMPTE IM	<b>&lt; 0.01% at 5 V out</b>

### **LINE LEVEL OUTPUTS**

Pre-amp output impedance	<b>100 ohms</b>
Tape output impedance	<b>Source Z + 1kohms</b>
Maximum output level	pre-amp out : <b>&gt; 12 V</b> Tape-out : <b>&gt; 10 V</b>

### **CONTROLS**

Treble	<b>5 dB at 10 kHz</b>
Bass	<b>7 dB at 100 Hz</b>

### **DIMENSIONS AND WEIGHTS**

Net Weight	<b>6.5 kg ( 14.3 lb)</b>
Shipping Weight	<b>7.7 kg ( 17 lb)</b>
DIMENSION (W•H•D)	<b>435 • 109 • 290MM</b>

# DISASSEMBLY INSTRUCTIONS

## TOP COVER REMOVAL

1. Remove parts in order of disassembly as numbered.

- a. ①-④ Tap Tite Screws STPW4X8(See Fig.1.)
- b. ⑤ Tap Tite Screws STB3X6(See Fig.1.)

Fig.1.

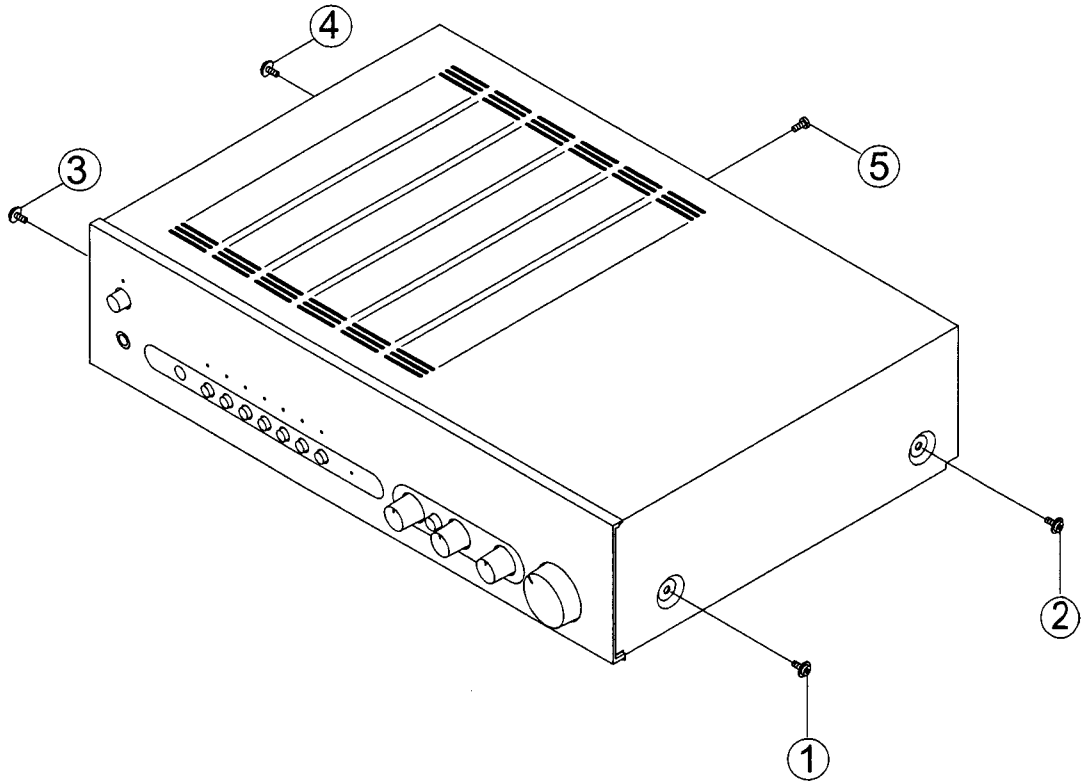

2. Pull both sides of TOP COVER outward and turning about 35° (shown as arrow ⑥) then remove as arrow ⑦ show. (See Fig.2.)

Fig.2.

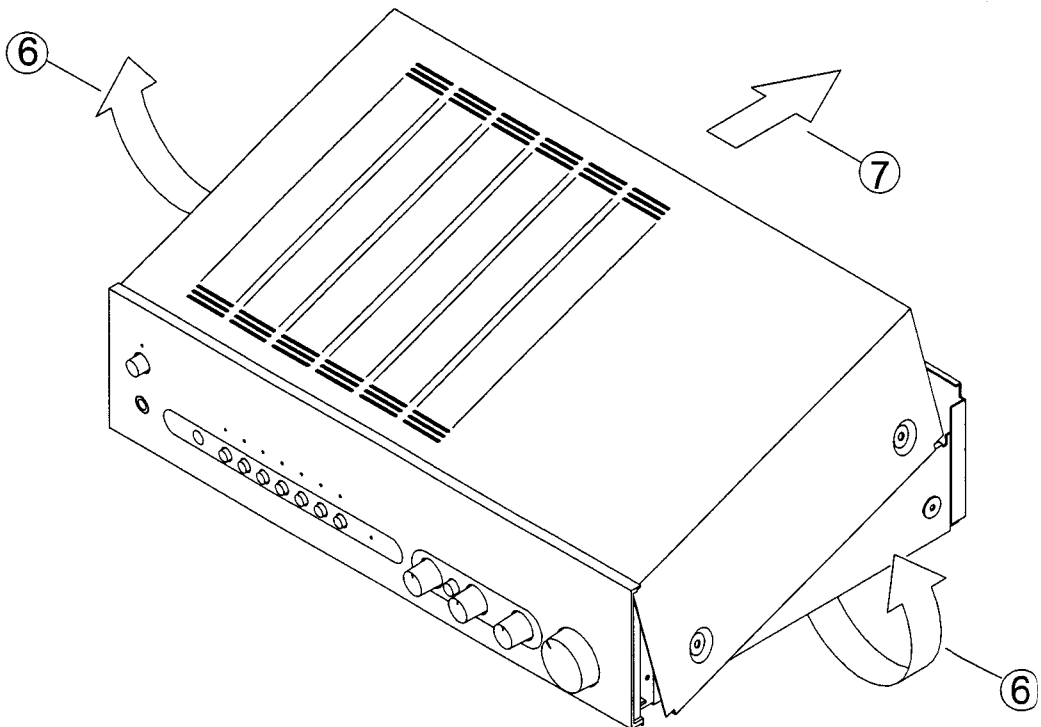

# ALIGNMENT PROCEDURE

## I. INITIAL ADJUSTMENT (No load connected)

### A. OUTPUT OFFSET VOLTAGE

1. Connect a DC Millivoltmeter to L Channel speaker output terminals.
2. Turn unit "ON" and adjust VR21 (1 kohms) to get a reading of  $0V \pm 30\text{ mV}$ .
3. Connect the DC Millivoltmeter to R Channel speaker output terminals and adjust VR 11 (1 kohms) to get a reading of  $0V \pm 30\text{ mV}$ .

### B. IDLING CURRENT

1. Connect a DC Millivoltmeter to TP1 and TP2 and adjust VR22 (300 ohms) for 7 – 9 mV reading on meter.
2. Connect the DC Millivoltmeter to TP3 and TP4 and adjust VR12 (300 ohms) for 7 – 9 mV reading on meter.
3. Leave power "ON" for a minimum of 5 minutes.

## II. FINAL ADJUSTMENT

Repeat procedure A and B for offset voltage and idling current alignment respectively.

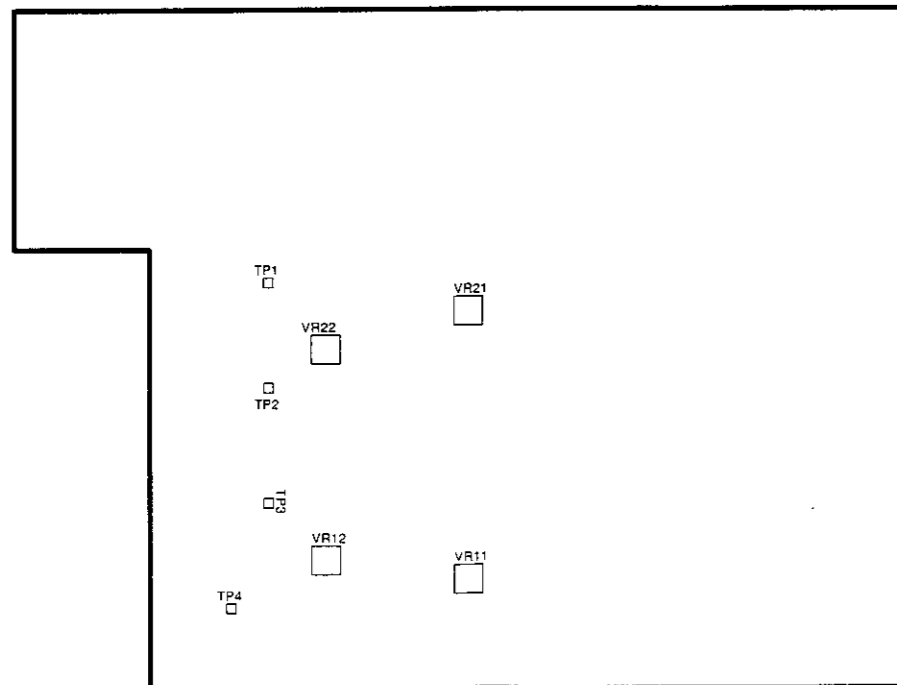

# PCB LAYOUT(SMALL BOARD)

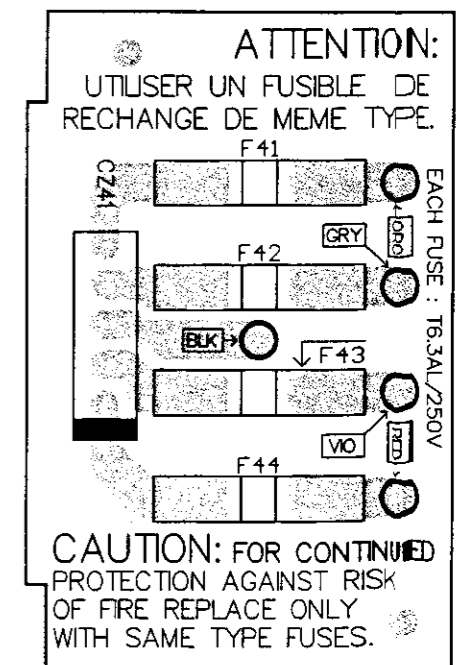
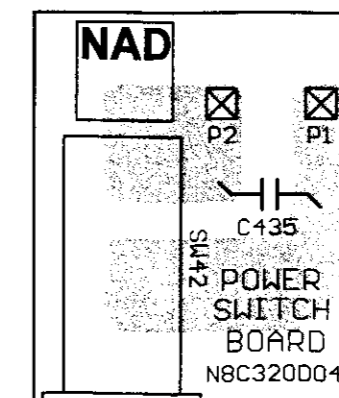
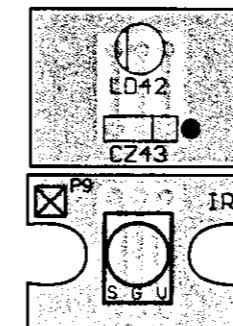
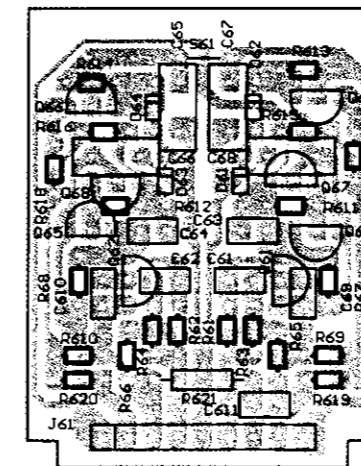
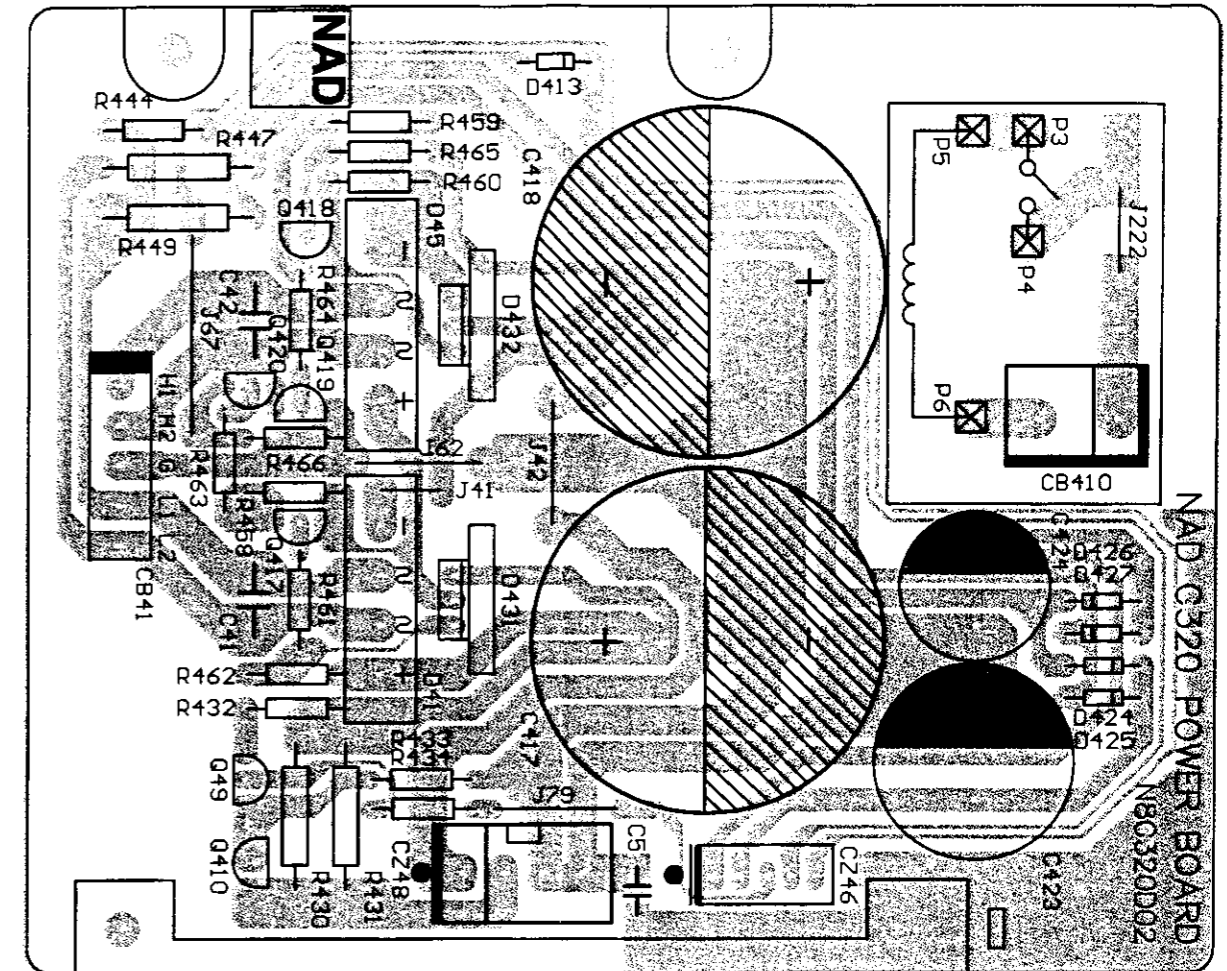

PCB LAYOUT(MAIN BOARD)

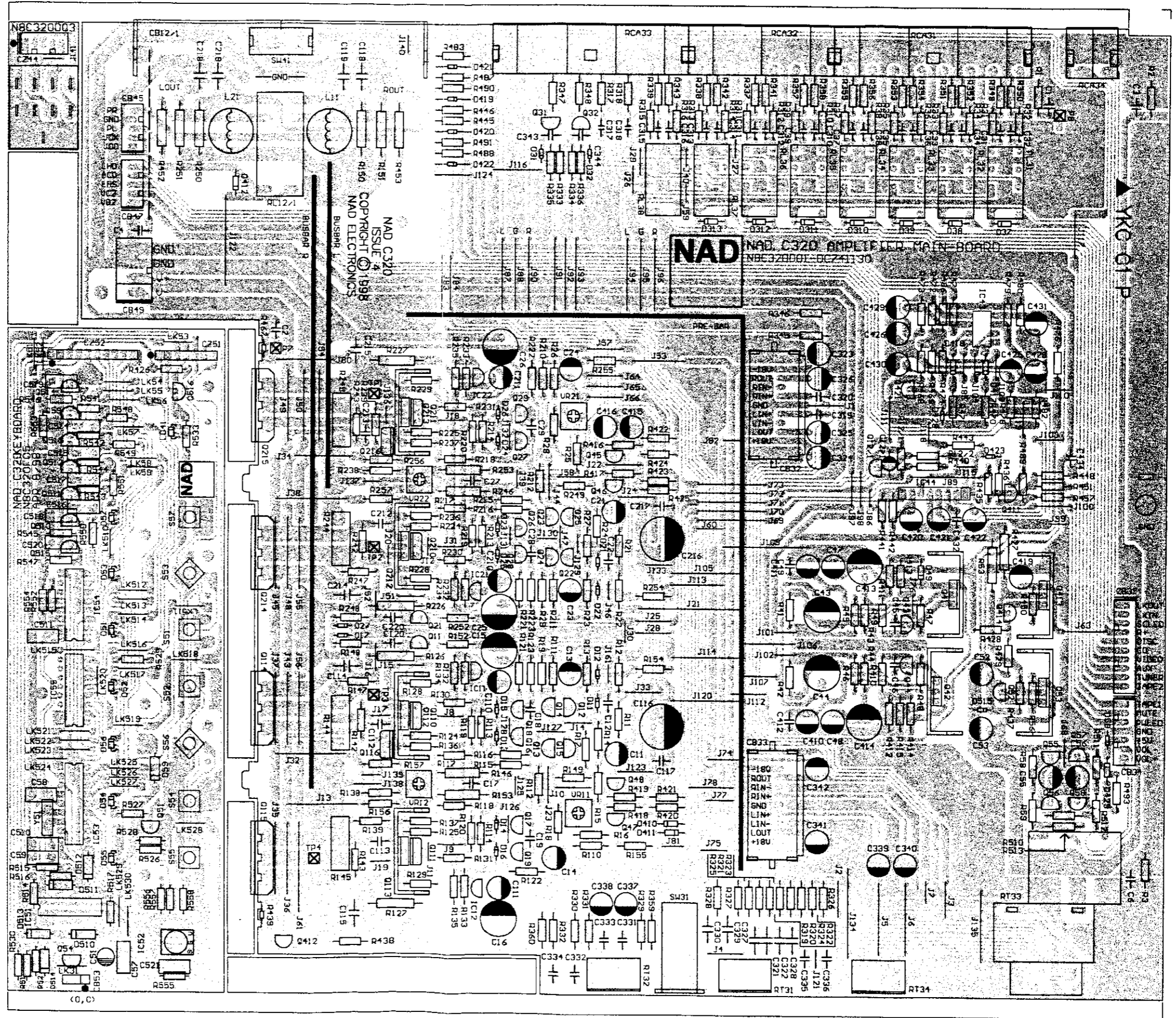





# SCHEMATIC DIAGRAM(POWER AMP)

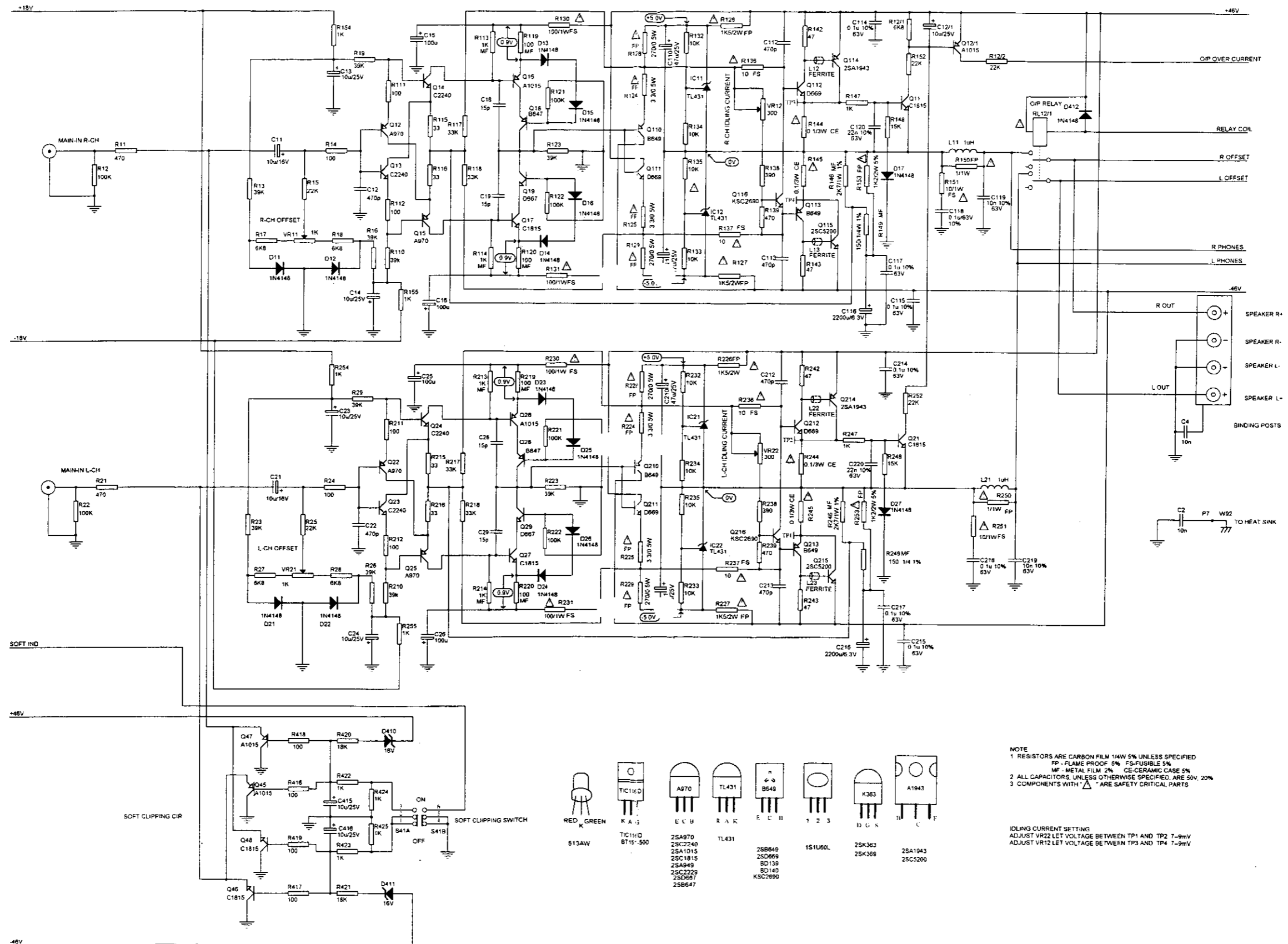

# SCHEMATIC DIAGRAM (KEY BOARD)

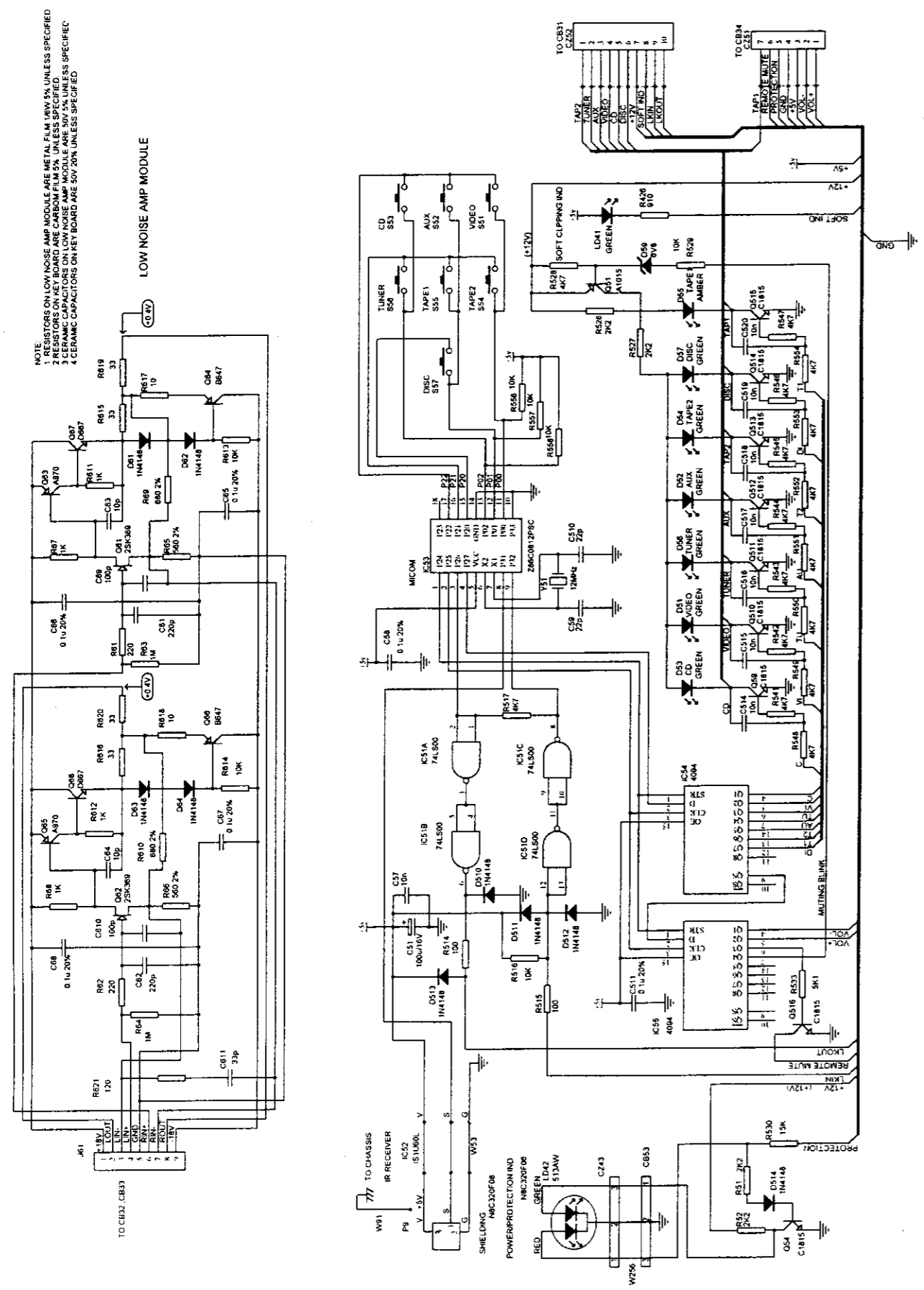

# IC BLOCK DIAGRAM

IC53: Z86C0812PSC

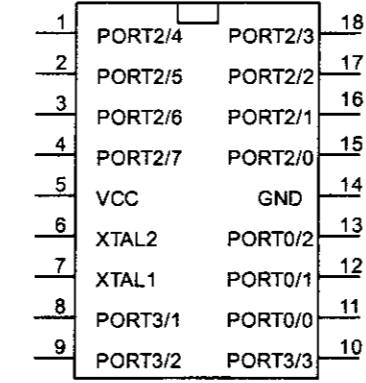

IC54, IC55: CD4094

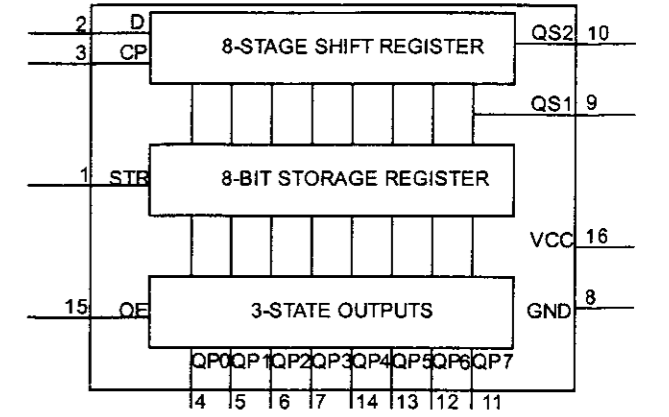

IC51: 74LS00

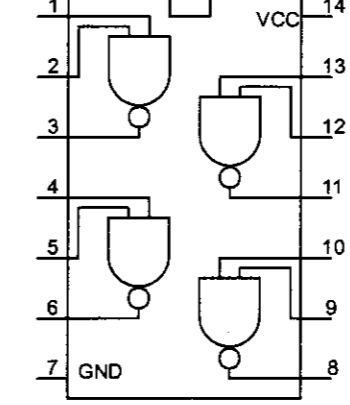

IC11, IC12, IC21, IC22: TL431

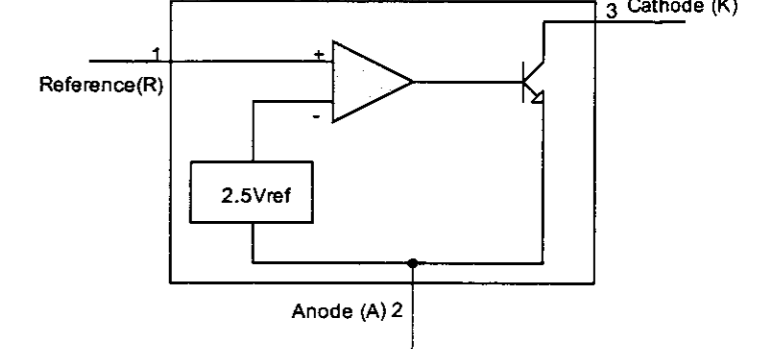

IC52: IS1U60L

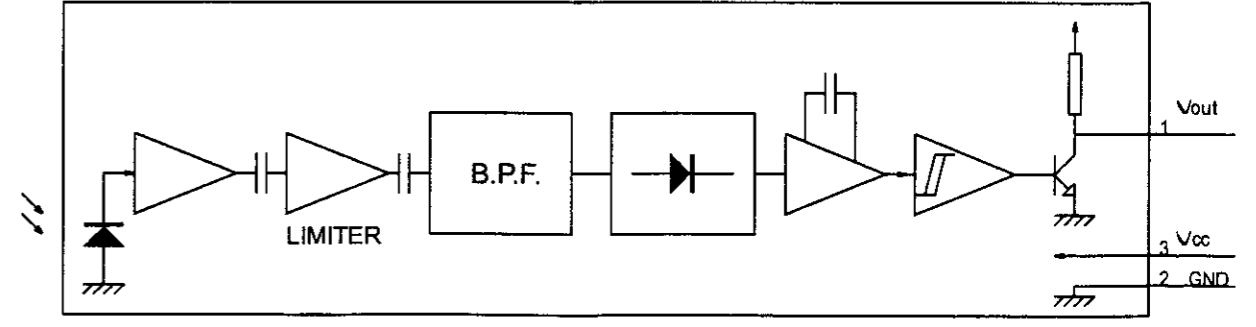

IC44: uPC1237HA

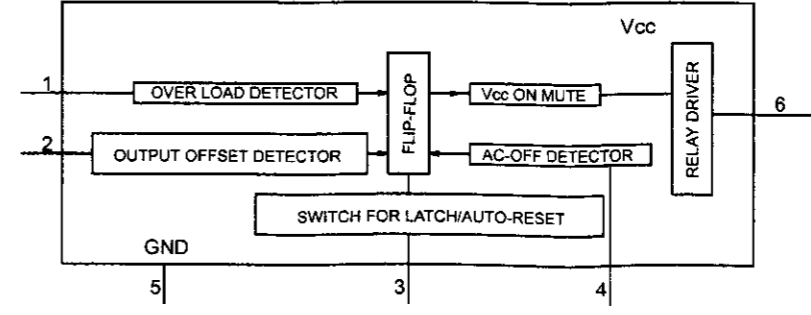

IC43: LT082

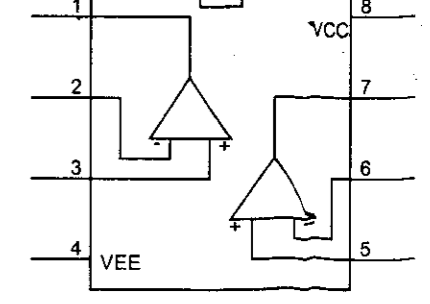

# WIRING DIAGRAM

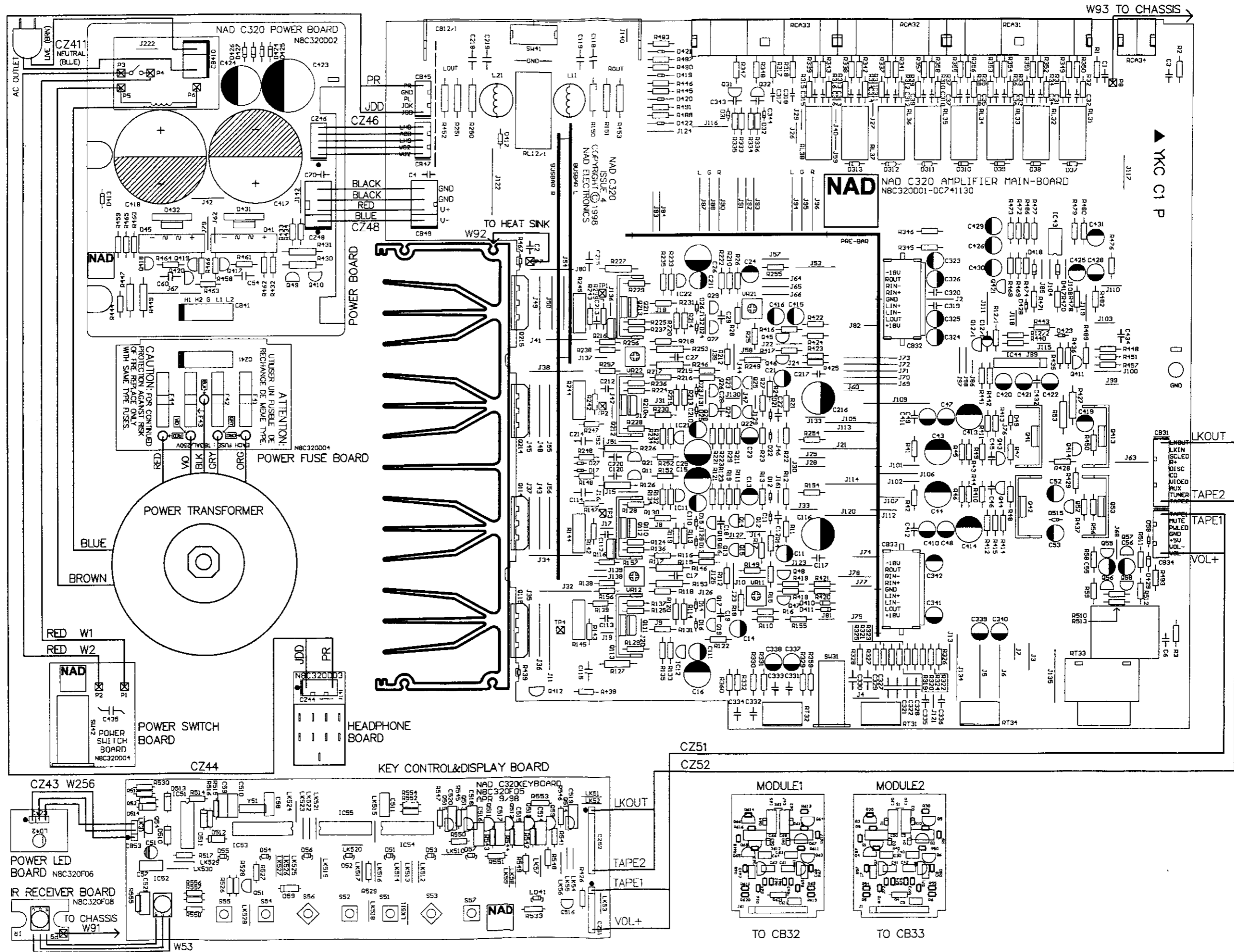

# ELECTRICAL PARTS LIST

Ref. No.	Part No.	Description				
<b>RESISTORS</b>						
		CF:Carbon Film				
		FP:Flame Proof				
		FS:Fusible				
		MF:Metal Film				
		CE:Ceramic Case				
⚠ R41, R42	07-05681-04C	680	0.25W	%	FS	
⚠ R45, R46	07-05330-02C	33	0.5W	%	FS	
⚠ R53	07-05820-10C	82	1W	%	FS	
R61, R62	07-05221-06D	220	1/6W	%	MF	
R63, R64	07-05105-06D	1M	1/6W	%	MF	
R65, R66	07-02561-06D	560	1/6W	%	MF	
R67, R68	07-05102-06D	1k	1/6W	%	MF	
R69	07-02681-06D	680	1/6W	%	MF	
⚠ R124, R125	07-05033-02B	3.3	0.25W	%	FP	
⚠ R126, R127	07-05152-20B	1.5k	2W	%	FP	
⚠ R128, R129	07-05271-02B	270	0.25W	%	FP	
⚠ R130, R131	07-05101-10C	100	1W	%	FS	
⚠ R136, R137	07-05100-04C	10	0.25W	%	FS	
R144, R145	07-05001-30A	0.1	3W	%	CE	
R146	07-01272-02D	2.7k	0.5W	%	MF	
R149	07-01151-04D	150	0.25W	%	MF	
⚠ R150	07-05010-10B	1	1W	%	FP	
⚠ R151	07-05100-04C	10	1W	%	FS	
⚠ R153	07-05122-10B	1.2k	1W	%	FP	
⚠ R224, R225	07-05033-02B	3.3	0.25W	%	FP	
⚠ R226, R227	07-05152-20B	1.5k	2W	%	FP	
⚠ R228, R229	07-05271-02B	270	0.25W	%	FP	
⚠ R230, R231	07-05101-10C	100	1W	%	FS	
⚠ R236, R237	07-05100-04C	10	0.25W	%	FS	
⚠ R244, R245	07-05001-30A	0.1	3W	%	CE	
R246	07-01272-02D	2k7	1W	%	MF	
R249	07-01151-04D	150	0.25W	%	MF	
⚠ R250	07-05010-10B	1	1W	%	FP	
⚠ R251	07-05100-10C	10	1W	%	FS	
⚠ R253	07-05122-10B	1k2	1W	%	FP	
R319, R320	07-02822-04D	8k2	0.25W	%	MF	
R321, R322	07-02332-04D	3k3	0.25W	%	MF	
R323, R324	07-02821-04D	820	0.25W	%	MF	
R325, R326	07-02102-04D	1k	0.25W	%	MF	
R327, R328	07-02271-04	270	0.25W	%	MF	
R329, R330	07-02222-04D	2.2k	0.5W	%	MF	
R331, R332	07-02561-04D	560	0.25W	%	MF	
R359, R360	07-05472-04	4k7	1W	%	MF	
R412	07-02203-04D	20k	0.25W	%	MF	
R414	07-02223-04D	22k	0.25W	%	MF	
⚠ R427	07-05271-20B	270	2W	%	FP	
⚠ R430, R431	07-05001-10B	0.1	1W	%	FP	
⚠ R439	07-9001-00T	t0=90	PTH9M04BE4-71TS2F333		Posistor	
⚠ R443	07-05561-04C	560	0.5W	%	FS	
⚠ R447	07-05022-10C	2.2	1W	5%	FS	
⚠ R449	07-05022-10C	2.2	1W	5%	FS	
⚠ R452, R453	07-05221-20B	220	2W	5%	FP	
⚠ R467	07-80001-00T	t0=80	PTH9M04BF4-71TS2F333		Posistor	
R610	07-02681-06D	680	1/6W	%	MF	
R611, R612	07-05102-06D	1k	1/6W	%	MF	

Ref. No.	Part No.	Description				
R613, R614	07-05103-06D	10k	1/6W	%	MF	
R615, R616	07-05330-06D	33	1/6W	%	MF	
R617, R618	07-05100-06D	10	1/6W	%	MF	
R619, R620	07-05330-06D	33	1/6W	%	MF	
R621	07-05121-06D	120	1/6W	%	MF	
<b>CAPACITORS</b>						
					Cer:Cermic Disk	
					Mono:Monolithic	
					EL:Electrolytic	
					Poly:Polyester	
					MP:Metallized Polyester Film	
C3	05-10104-20	0.1u	50V	0%	Mono	
C11	06-16106-20	10u	16V	0%	EL	
C12/1	05-25106-20	10u	25V	0%	EL	
C13, C14	06-25106-20	10u	25V	0%	EL	
C15, C16	06-50107-20	100u	50V	0%	EL	
C21	06-16106-20	10u	16V	0%	EL	
C23, C24	06-25106-20	10u	25V	0%	EL	
C25, C26	06-50107-20	100u	50V	0%	EL	
⚠ C41, C42	05-22103-10	10n	250V	0%	MP	
C43, C44	06-50227-20	220u	50V	0%	EL	
C47	06-25476-20	47u	25V	0%	EL	
C48	06-25106-20	10u	25V	0%	EL	
C49	06-25476-20	47u	25V	0%	EL	
C51	06-16107-20	100u	16V	0%	EL	
C52, C53	06-25476-20	47u	25V	0%	EL	
C55, C56	06-50475-20	4u7	25V	0%	EL	
C58	05-10104-20	0.1u	50V	0%	Mono	
C65--C68	05-10104-20	0.1u	50V	0%	Mono	
C110, C111	06-25476-20	47u	25V	0%	EL	
C114, C115	05-30104-10	0.1u	63V	0%	Poly	
C116	06--06228-20	2200u	6.3V	0%	EL	
C117	05-30104-10	0.1u	63V	0%	Poly	
C118	05-20104-10	100n	63V	0%	MP	
C119	05-20103-10	10n	63V	0%	MP	
C120	05-30223-05	22n	63V	0%	Poly	
C210, C211	06-25476-20	47u	25V	0%	EL	
C214, C215	05-30104-10	0.1u	63V	0%	Poly	
C216	06-06228-20	2200u	6.3V	0%	EL	
C217	05-30104-10	0.1u	63V	0%	Poly	
C218	05-20104-10	100n	63V	0%	MP	
C219	05-20103-10	10n	63V	0%	MP	
C220	05-30223-05	22n	63V	0%	Poly	
C319, C320	05-30104-10	0.1u	63V	0%	Poly	
C323--C326	06-25476-20	47u	25V	0%	EL	
C327, C328	05-30183-05	18n	63V	%	Poly	
C329, C330	05-30104-05	0.1u	63V	%	Poly	
C331, C332	05-20224-05A	0.22u	63V	%	MP	
C333, C334	05-20105-05A	1u	63V	%	MP	
C339, C340	06-16105-20	1u	16V	0%	EL	
C341, C342	06-25476-20	47u	25V	0%	EL	
C410	06-25476-20	47u	25V	0%	EL	
C411, C412	05-30104-10	0.1u	63V	0%	Poly	
C413, C414	06-35227-20	220u	35V	0%	EL	
C415, C416	06-25106-20	10u	25V	0%	EL	
C417, C418	06-50159-10	15000i	50V	0%	EL	
C420	06-50336-20	33u	50V	0%	EL	

# ELECTRICAL PARTS LIST CONTINUE

Ref. No.	Part No.	Description		
C421	06-50475-20	4u7	50V	0% EL
C422	06-16337-20	330u	16V	0% EL
C423	06-50338-20	3300u	50V	0% EL
C424	06-50228-20	2200u	50V	0% EL
C425, C426	06-25106-20	10u	25V	0% EL
C428--C431	06-25106-20	10u	25V	0% EL
△ C432	05-10224-20	0.22u	50V	0% Mono
C434	05-30223-05	22n	+	0% MP
C435	05-04473-20	4n7	400VAC	0% Cer
C511	05-10104-20	0.1u	50V	0% Mono
<b>POTENTIOMETERS</b>				
VR11, VR21	10-01103-00T	1k		Semi Pot
VR12, VR22	10-01301-00T	300		Semi Pot
<b>ICS</b>				
IC11, IC12	01-10431-000	TA76431(TL431)		Shunt Regulator
IC21, IC22	01-10431-000	TA76431(TL431)		Shunt Regulator
IC43	03-00082-08	TL082CP		Dual OP-AMP
IC44	03-01237-08	uPC1237HA		Protection IC
IC51	03-00074-14	74LS00		TTL
IC52	03-10060-00	IS1U60L		IR Receiver
IC53	03-00812-18	Z86C0812PSC		NAD MICOM
IC54, IC55	03-04094-16	CD4094		CMOS
<b>DIODES</b>				
D11--D17	02-24148-00	1N4148		SW Diode
D21--D27	02-24148-00	1N4148		SW Diode
D31, D32	02-24148-00	1N4148		SW Diode
D37--D39	02-24148-00	1N4148		SW Diode
D41, D45	02-42008-00	8A, 200V		Bridge Rect.
D49	02-00180-05	0.5W 18V		Zener Diode
D51--D54	02-33144-053	3144D		Green LED
D55	02-3000-033	3127D		Amber LED
D56, D57	02-33144-053	3144D		Green LED
D58	02-00056-05	0.5W 5V6		Zener Diode
D59	02-00068-05	0.5W 6V8		Zener Diode
		02-24148-00	1N4148	SW Diode
D310--D313	02-24148-00	1N4148		SW Diode
D410, D411	02-00160-05	0.5W 16V		Zener Diode
D412	02-24148-00	1N4148		SW Diode
D413	02-14002-00	1N4002		Rect. Diode
D417--D420	02-24148-00	1N4148		SW Diode
D423	02-24148-00	1N4148		SW Diode
D424--D427	02-14002-00	1N4002		Rect. Diode
D428, D429	02-24148-00	1N4148		SW Diode
D431, D432	01-201160-003	TIC116D		Thyristor
	or 01-201510-003	BT151-500R		Thyristor
D510--D514	02-24148-00	1N4148		SW Diode
D515	02-00075-05	0.5W 7V5		Zener Diode
LD41	02-33144-053	3144D		Green LED
LD42	02-30515-255	COM-Cathode		Dual Color LED
<b>TRANSISTORS</b>				
Q11	01-01815-070	2SC1815 GR		
Q12	01-00970-070	2SA970 GR		
Q12/1	01-01015-070	2SA1015 GR		
Q13, Q14	01-02240-070	2SC2240		
Q15	01-00970-070	2SA970 GR		
Q16	01-01015-070	2SA1015 GR		

Ref. No.	Part No.	Description	
Q17	01-01815-070	2SC1815 GR	
Q18	01-00949-004	2SA949	
	or 01-00647-004	2SB647	
Q19	01-02229-004	2SC2229	
	or 01-00667-004	2SD667	
Q21	01-01815-070	2SC1815 GR	
Q22	01-00970-070	2SA970 GR	
Q23, Q24	01-02240-070	2SC2240	
Q25	01-00970-070	2SA970 GR	
Q26	01-01015-070	2SA1015 GR	
Q27	01-01815-070	2SC1815 GR	
Q28	01-00949-004	2SA949	
	or 01-00647-004	2SB647	
Q29	01-02229-004	2SC2229	
	or 01-00667-004	2SD667	
Q31, Q32	01-00363-000	2SK363	
Q41	01-00139-001	2SD669A	
Q42	01-00140-001	2SB649A	
Q43	01-01815-070	2SC1815 GR	
Q44, Q45	01-01015-070	2SA1015 GR	
Q46	01-01815-070	2SC1815 GR	
Q47	01-01015-070	2SA1015 GR	
Q48	01-01815-070	2SC1815 GR	
Q49--Q51	01-01015-070	2SA1015 GR	
Q52	01-01815-070	2SC1815 GR	
Q53	01-00669-001	2SD669	
Q54	01-01815-070	2SC1815 GR	
Q55--Q58	01-01015-070	2SA1015 GR	
Q59	01-01815-070	2SC1815 GR	
Q61, Q62	01-00369-070	2SK369 GR	
Q63	01-00970-070	2SA970 GR	
Q64	01-00949-004	2SA949	
	or 01-00647-004	2SB647	
Q65	01-00970-070	2SA970 GR	
Q66	01-00949-001	2SA949	
	or 01-00647-004	2SB647	
Q67, Q68	01-02229-004	2SC2229	
	or 01-00667-004	2SD667	
Q110	01-00649-001	2SB649	
Q111, Q112	01-00669-001	2SD669	
Q113	01-00649-001	2SB649	
Q114	01-01943-002	2SA1943	
Q115	01-05200-002	2SC5200	
Q116	01-02690-001	KSC2690(hFE>200)	
Q210	01-00649-001	2SB649	
Q211, Q212	01-00669-001	2SD669	
Q213	01-00649-001	2SB649	
Q214	01-01943-002	2SA1943	
Q215	01-05200-002	2SC5200	
Q216	01-02690-001	KSC2690(hFE>200)	
Q410, Q411	01-01015-070	2SA1015 GR	
Q412	01-01815-070	2SC1815 GR	
Q413	01-00669-001	2SD669	
Q414	01-01815-070	2SC1815 GR	
Q417	01-01015-070	2SA1015 GR	
Q418	01-01815-070	2SC1815 GR	
Q419	01-01015-070	2SA1015 GR	
Q420, Q421	01-01815-070	2SC1815 GR	
Q510--Q516	01-01815-070	2SC1815 GR	

## ELECTRICAL PARTS LIST CONTINUE

Ref. No.	Part No.	Description
<b>RELAYS</b>		
⚠ RL12/1	12-02024-05	DPST
RL31--RL38	12-02012-01	DPDT
<b>FUSE</b>		
⚠ F41--F44	20-00630-25	T6.3AL250V Fuse
<b>CRYSTAL</b>		

Ref. No.	Part No.	Description
Y51	04-12000-00	12.000MHz Crystal Resonator
<b>INDUCTORS</b>		
L11	08-15580-10	1uH Spring Coil
L12, L13	19-05050-00	φ5 φ3.5 Ferrite Bead
L21	08-15580-10	1uH Spring Coil
L22, L23	19-05050-00	φ5 φ3.5 Ferrite Bead

Parts marked with the symbol ⚠ are critical with regard to the risk of fire and electric shock. Replace only with parts recommended by the manufacturer.

## EXPLODED VIEW PARTS LIST

Ref. No.	Part No.	Description	Qty	Ref. No.	Part No.	Description	Qty
C001	45-00320-01	Chassis	1	F003	53-00320-02	Input Lozenge	1
C002	45-00320-04	Base Cover	1	F004	51-00320-01	Volume Knob	1
C003	53-00320-05	Foot	4	F005	51-00320-02	Tone Control Knob	3
C005	17-02200-04	Binding Post	1	F006	54-00320-01	IRS Lens	1
C006	16-0C320-02	Supply Board	1	F007	45-00320-11	IR Cover	1
C007	40-08045-22	Bolt	1	F008	16-0C320-05	Key Board	1
C008	45-00320-07	Trans. Bracket	1	F009	53-00320-03	Input Button	3
C009	46-00320-03	Shielding Box	1	F010	52-00320-02	Power Button	1
C010	43-08002-00	Spring Washer	2	F011	53-00320-04	Bezel	1
C011	41-08008-00	Nut	2	F012	57-00320-02	Chassis Connector	1
C012	56-00320-05	Rubber Pad	2	F013	54-00320-02	LED Lens	1
C013	45-00320-10	Fuse Board Bracket	1	F014	11-00004-01	Tack Switch	1
C014	16-0C320-09	Fuse Board	1	F015	52-00320-01	Tone Defeat Button	1
C015	47-00320-04	Heatsink (Big) Plate	1	S001	45-00320-03	SubFascia	1
C016	45-00320-08	Module Support	2	⚠ S002	11-01001-00	Power Switch	1
C017	47-00320-01	Heatsink A	8	S003	17-00200-01	Headphone Jack	1
C018	16-0C320-01	Main Board	1	S004	16-0C320-06	LED Board	1
C019	09-16103-12	Bass POT	1	S005	56-00320-04	Insulating Washer (5mm)	1
C020	11-01022-01	Push Switch	1	S007	16-0C320-03	Phones Board	1
C021	09-16103-12	Treble POT	1	S008	16-0C320-04	Power Switch Board	1
C022	09-16203-02	Balance POT	1	T001	46-00320-01	Top Cover	1
C023	09-16203-22M	Volume POT	1	R001	46-00320-02	Real Panel	1
C024	19-05050-00	Ferrite Bead	4	⚠ R004*C	15-00183-00	AC Power Cord for C Version European Model only.	1
⚠ C025*B,B1,C	18-65381-00	Transformer for 230V Version	1	⚠ R004*AH	15-00183-01	AC Power Cord for AH Version USA, Canadian Model Only.	1
⚠ C025*AH	18-65382-00	Transformer for 120V Version	1	⚠ R004*B1	15-00183-02	AC Power Cord for B1 Version Australian Model Only.	1
C026	45-00320-09	Transformer Disc	1	⚠ R004*B	15-00183-03	AC Power Cord for B Version UK Model Only	1
C027	56-00320-01	Foot Pad	4	⚠ R005	58-00320-01	Strain Relief Bushing	1
C028	56-00320-02	Heat Conductive Pads	4	R006	49-00320-01	Shorting Plug	2
C029	57-00320-01	Chassis Connector	2	R006	49-00320-01	Shorting Plug	2
C030	59-00320-01	Spacer Support	1	0001	40-04008-01	Tap tite Screw (4 8)	8
C032	58-00320-02	Cable Tie	5	0002	40-04012-22	Tap tite Screw (4 12)	2
C034	48-00320-02	R-CH Output Bar	1	0003	40-03008-01	Self Taping Screw	14
C035	48-00320-04	Ground Bar	1	0004	40-13008-01	Taping Screw (3 8)	18
C036	11-02022-02	Slide Switch	1	0005	40-12604-01	Taping Screw (2.6 4)	2
C037	16-0C320-07	Module PCB	1				
C038	17-01200-06	RCA 6 Holes	1				
	17-01200-08	RCA 4 Holes	4				
	17-01200-02	RCA 2 Holes	1				
F001	55-00320-01	Fascia	1				
F002	53-00320-01	Tone Control Lozenge	1				

Parts marked with the symbol ⚠ are critical with regard to the risk of fire and electric shock. Replace only with parts recommended by the manufacturer.





# PACKING DIAGRAM

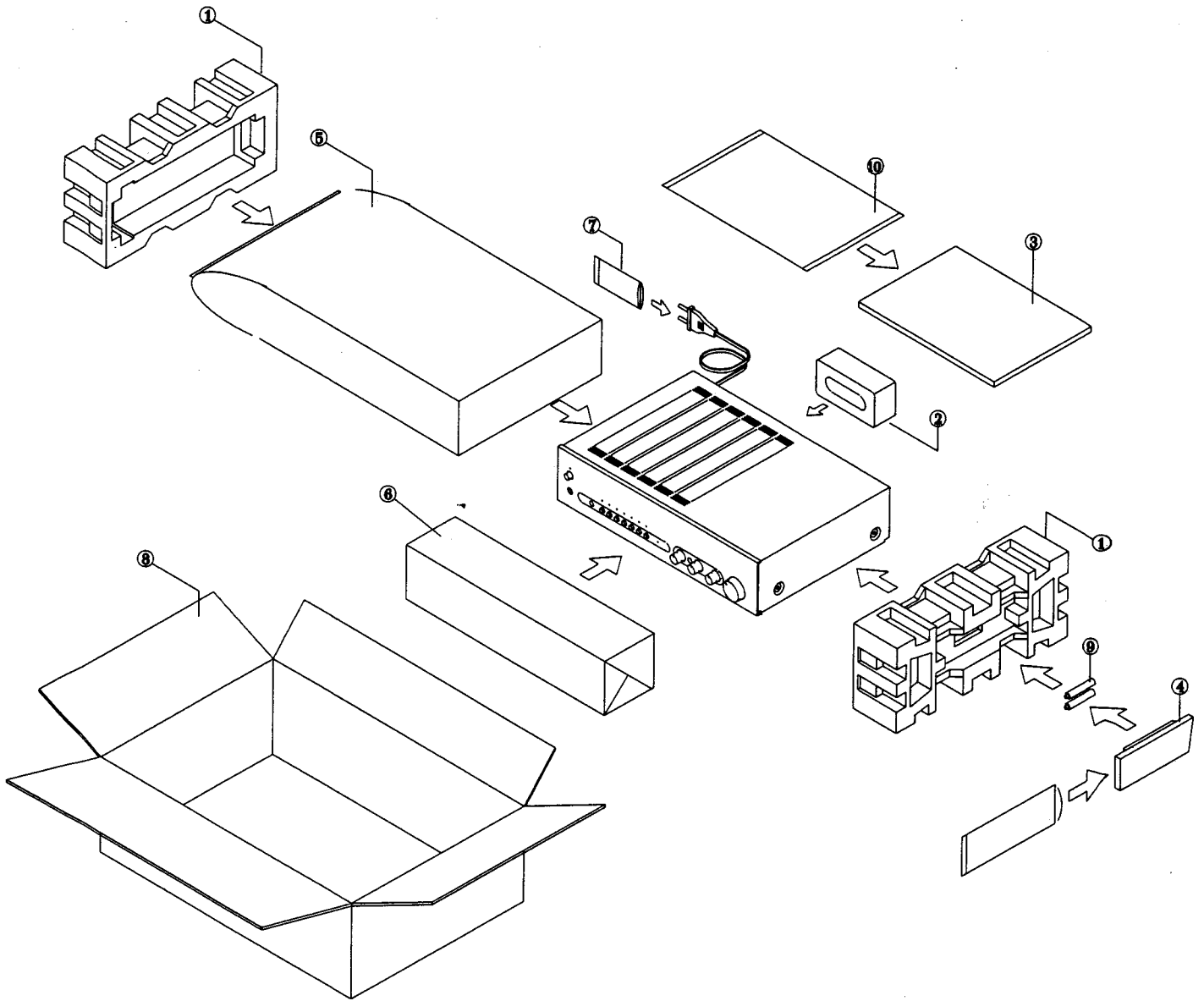

Ref.No.	Part No.	Description	Q'TY
1.	62-00320-01	Polyfoam End Cap	2
2.	62-00320-02	Polyfoam BDP Unit	1
3.	65-00320-01	Instruction Manual	1
4.	30-0C320-00	Remote Control Unit	1
5.	63-00320-01	Polybag	1
6.	64-00320-02	EPE Film	1
7.	63-00320-03	AC Cord Polybag	1
8.	61-00320-01	Carton Box	1
9.	31-07150-00	Batteries	2
10.	63-00320-02	Manual Polybag	1

Proprietary information for servicing purposes only.  
 The information herein may not be used commercially without the prior written agreement of NAD Electronics Ltd., London England.