

**NAD SERVICE
MANUAL**

**7220PE
7020e
AM/FM RECEIVERS**

CONTENTS
-7220PE / 7020e

REAR / FRONT PANEL CONNECTIONS	PAGE 3
SPECIFICATIONS	PAGE 4
ALIGNMENT METHOD	PAGE 5 - 10
PCB LAYOUT AND WIRING DIAGRAM, AMP , 7220PE / 7020e	PAGE 11 - 12
PCB LAYOUT AND WIRING DIAGRAM, TUNER , 7220PE / 7020e	PAGE 13 - 14
PCB LAYOUT, AMP , 7220PE	PAGE 15 - 16
SCHEMATIC DIAGRAM, AMP , 7220PE	PAGE 17 - 18
PCB LAYOUT, AMP , 7020e	PAGE 19 - 20
SCHEMATIC DIAGRAM, AMP , 7020e	PAGE 21 - 22
PCB LAYOUT, TUNER , 7220PE / 7020e	PAGE 23 - 24
SCHEMATIC DIAGRAM, TUNER , 7220PE / 7020e	PAGE 25 - 26
PARTS LIST, EXPLODED VIEW	PAGE 27 - 30
EXPLODED VIEW	PAGE 31
PACKING DIAGRAM	PAGE 32

EAR PANEL

- AC Line Cord.
- AC Outlets.
- Speakers A.
- Speakers B.
- Antenna Terminals.
- Phono Ground.
- 7. Phono Input.
- 8. Video Sound Input.
- 9. CD Input.
- 10. Tape Input/Output.
- 11. Soft Clipping.
- 12. Speaker Impedance.

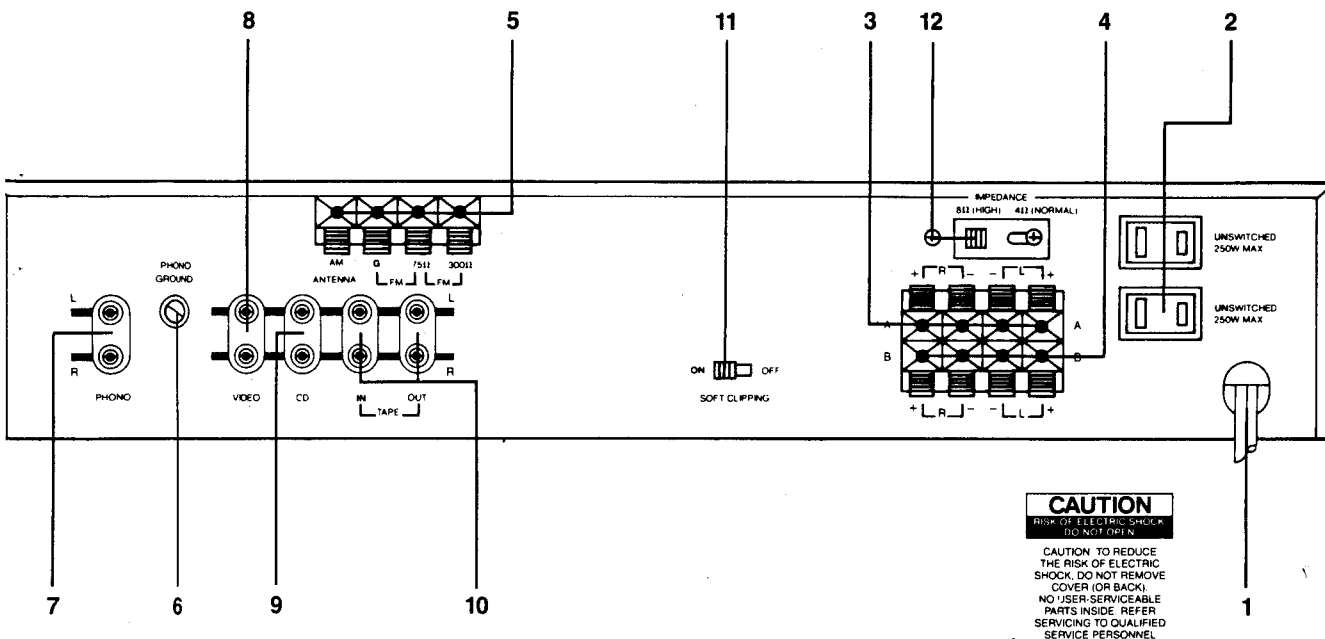

CAUTION
 RISK OF ELECTRIC SHOCK
 DO NOT OPEN
 CAUTION TO REDUCE
 THE RISK OF ELECTRIC
 SHOCK, DO NOT REMOVE
 COVER (OR BACK).
 NO USER-SERVICEABLE
 PARTS INSIDE. REFER
 SERVICING TO QUALIFIED
 SERVICE PERSONNEL

FRONT PANEL

- Power.
- Phones.
- Extra Speakers.
- Bass.
- Treble.
- Balance.
- 7. Tape Monitor.
- 8. Input Selector.
- 9. Mono.
- 10. Loudness.
- 11. Volume.
- 12. Tuning Display.
- 13. Center-tune Indicator.
- 14. FM Stereo Indicator.
- 15. Tuning Pre-sets.
- 16. Memory Enter.
- 17. Search Mode.
- 18. Up/Down Tuning.

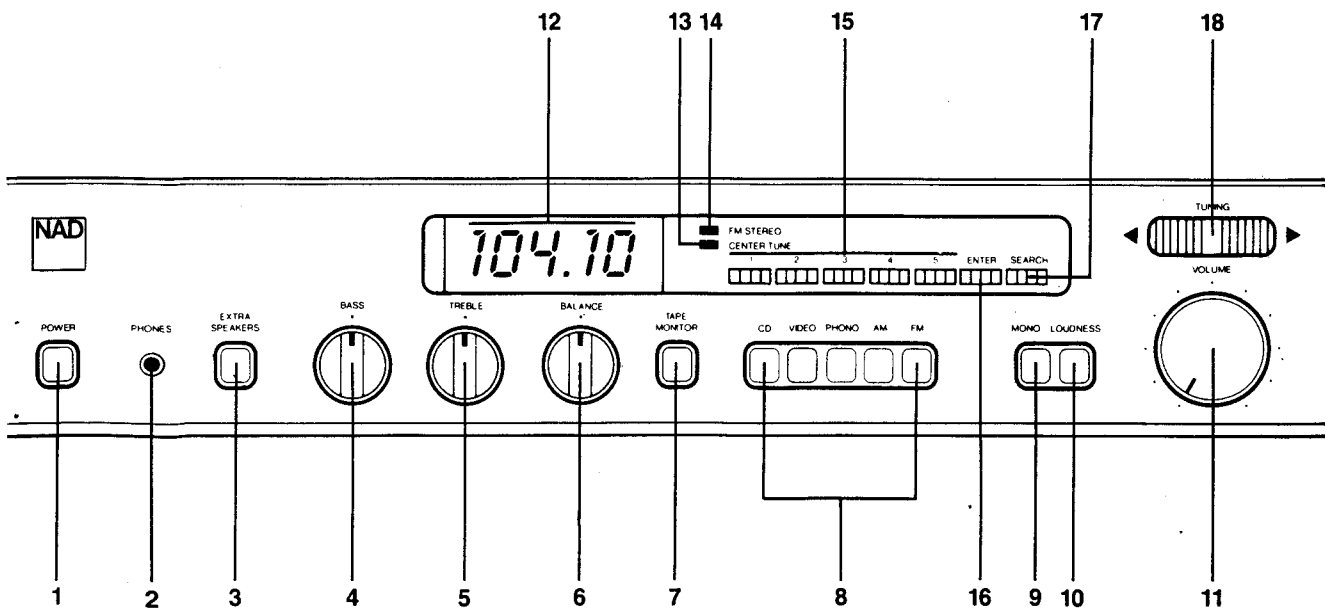

Specifications

NAD 7220PE Stereo Receiver

Note: Specifications are measured in accordance with EIA Standard RS-490 (IHF A-202) for amplifiers and ANSI-IEEE Standard 185 (1975), i.e. IHF T-200, for tuners. Amplifier measurements referred to 8 ohms are taken with the Speaker Impedance selector set to 8Ω (High). Measurements for 4 and 2 ohms are taken with Impedance selector at 4Ω (Normal).

Power Amplifier Section

CONTINUOUS AVERAGE POWER OUTPUT

AT 8 OHMS (minimum RMS power per channel, both channels driven, with no more than the rated distortion) **20 W (13 dBW)**

Rated distortion (THD), 20 Hz - 20 kHz 0.04%

Clipping power, 1 kHz (maximum continuous power per channel) 25 W

Dynamic Headroom at 8 ohms +4.4 dB

Dynamic power (maximum short-term power per channel)
8 ohms 55 W
4 ohms 75 W
2 ohms 85 W

Slew factor > 50

Slew rate 15V/μsec

Damping factor (ref. 8 ohms, at 50 Hz) > 30

T.H.D and SMPTE I.M. distortion from 250 mW to rated output < 0.04%

IHF I.M. (CCIF IM) and T.I.M. distortion at rated output < 0.04%

Preamplifier Section

Phono Input

Input Impedance R = 47KΩ , C = 100 pF

Input Sensitivity (1 kHz) 0.55 mV for 1 W out
 2.4 mV for 20 W out
 75 dB re 5 mV

Signal-to-Noise Ratio with cartridge connected, A-weighted 20/200/1700 mV

Input Overload at 20 Hz/1kHz/20kHz ±0.5 dB

High-Level Inputs (CD, Video, Tape)

Input Impedance R = 40 kΩ , C = 100 pF

Input Sensitivity 33 mV for 1W out
 150 mV for 20W out

Signal-to-Noise ratio, A-weighted 84 dB re 1 W out
 97 dB re 20W out

Input Overload >10 V

Frequency Response 20Hz - 20kHz +0.5, -1.0 dB

Infrasonic Filter -3 dB at 15 Hz
 24 dB/octave

Controls

Treble ±7 dB at 10kHz

Bass ±10 dB at 50 Hz

FM Tuner Section

Input sensitivity
Mono, -30 dB THD+N 10.8 dBf (1.9 μV/300Ω , or 0.95 μV into 75Ω)
Mono, 50 dB S/N 14.4 dBf (2.9 μV/300Ω)
Stereo, 50 dB S/N 37 dBf (40 μV)
Stereo 60 dB S/N 47 dBf (120 μV)

Capture ratio (at 45 and 65 dBf) < 1.5 dB
AM rejection (at 65 and 85 dBf) > 60 dB
Selectivity 58 dB
Image rejection 70 dB
R.F. intermodulation 60 dB
I.F. rejection 90 dB
SCA rejection 60 dB
Subcarrier suppression (19 & 38 kHz) 60 dB
THD at 100% modulation Mono, 1 kHz 0.1%
100Hz-6kHz 0.2%
Stereo, 1 kHz 0.1%
100Hz-6kHz 0.3%

Signal-to-noise ratio **Mono** > 80 dB
IHF weighted, 65 dBf **Stereo** > 74 dB

Frequency response, 30Hz-15 kHz ±0.5 dB

Stereo separation 45 dB

AM Tuner Section

Usable sensitivity 5 μV

THD 0.5%

Selectivity 30 dB

Image rejection 45 dB

I.F. rejection 35 dB

S/N ratio (30% mod., 50 mV input) 45 dB

Physical Specifications

Width x Depth x Height 42 x 27.3 x 8 cm.
 6.5 x 10 3/4 x 3 3/8 in.

Net Weight 5.5 kg (12.1 lbs)

Shipping Weight 6.8 kg (15 lbs)

Power Consumption 50/60 Hz at 110, 120, 220, or 240 VAC
 150 W

Specifications are those in effect at the time of printing. NAD reserves the right to change specifications or designs at any time without notice.

Industrial Design: REINHOLD WEISS DESIGN/CHICAGO

ALIGNMENT METHOD

AUDIO SECTION 7220PE

IMPORTANT

Speaker Impedance switch should be in 8 ohm position while adjusting center volatge and idling current.

INITIAL ADJUSTMENT (No load connected)

A. CENTER VOLTAGE

1. Connect DC millivoltmeter to L channel output terminals.
2. Turn on and adjust to 0 V \pm 30mV with VR411 (100 ohm).
Connect DC millivoltmeter to R channel output terminals and adjust VR412 to 0 V \pm 30mV.

B. IDLING CURRENT

1. Remove solder short across R455 and R456.
2. Connect DC millivoltmeter across P403,P404 (output transistor's collector resistor) and adjust R443 for 26-30mV reading on meter.
Repeat adjust with R444, connecting meter across P405,P406.
3. Leave power on for minimum 5 minutes.

FINAL ADJUSTMENT

C. CENTER VOLTAGE

1. Repeat step A above.

D. IDLING CURRENT

1. Repeat step B and adjust with R443, R444 for 30mV reading on meter.
2. After the alignment is finished, 1 ohm resistor R455,R456 is shorted by solder short.

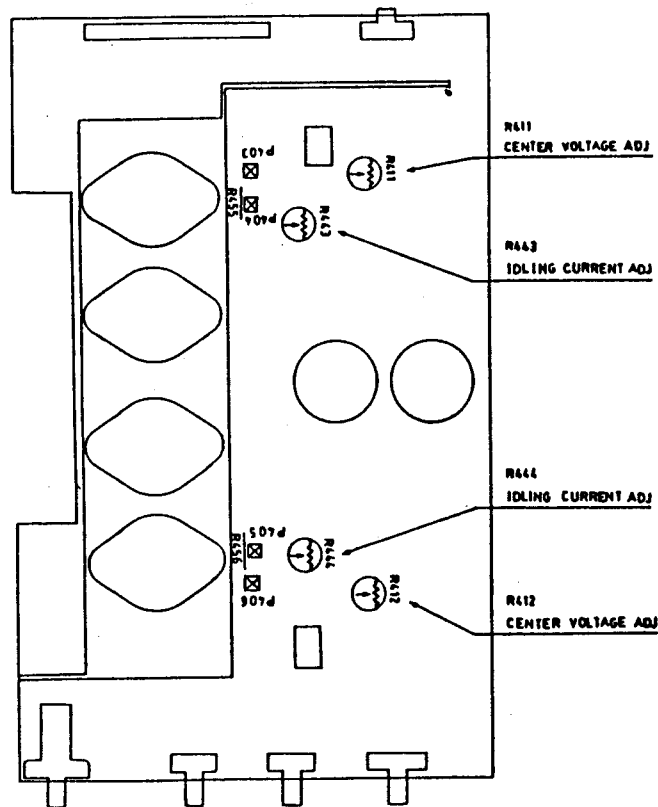

AMPLIFIER ADJUSTMENT POINTS

FM ALIGNMENTS

NECESSARY INSTRUMENTATION

FM GENERATOR (less than 0.05% THD)
STEREO GENERATOR (less than 0.05% THD, more than 50 dB separation at 1 KHz.)
AUDIO GENERATOR (not necessary if FM generator has built in sweep; i.e. SOUND TECHNOLOGY ST 1000A and ST 1020A)
2 AC VTVM's (or one with left/right channel switch)
THD ANALYZER (resolution better than 0.1%)
OSCILLOSCOPE (5mV or better sensitivity, X input capability)
FREQUENCY COUNTER
VOM or DMM (high impedance, must read in mV)
DIODE DETECTOR PROBE
COPPER/FERRITE INDUCTOR

IMPORTANT While all FM generator output levels hereafter are referred to the 300 ohm input, 75 ohm input can be used, but be aware of possible equipment groundloops and divide the RF output level by 2.
Before alignments commence set input selector to tuner and release tape, mono and FM NR. defeat switches (out)
ALIGNMENT OF FRONTEND should only be necessary after repair to frontend or crystal oscillator circuits (pin 2 and 3 on Q911)

A. TUNING VOLTAGE (OSCILLATOR)

It is essential to check tuning voltage before aligning the rest of the frontend.

1. Connect DMM between shield and pin 5 on frontend.
2. Tune to 108 MHz and adjust L 101 if voltage is incorrect.
SPECIFICATION 20.5V +/- 0.5V
3. Tune to 87.5 MHz and read voltage, repeat step 2 and 3 if incorrect.
SPECIFICATION 3V +/- 0.5V

B. RF ADJUSTMENT (TRACKING)

1. Connect RF generator to antenna input and detectorprobe to pin 1, Q104 (IF DETECTOR) with ground to detectorshield. Adjust sensitivity of oscilloscope to maximum (5mV or better) and modulate FM generator sweep +/- 300 KHz or more WITH modulating (sweep) signal connected to X-input of oscilloscope.
2. Set tuner to 90 MHz, enter into preset 1, and tune generator so that curve appears on oscilloscope. Turn down RF input level so that curve covers approximately 1/2 of oscilloscope display.
3. Check alignments of L 2 - L 4 - L 5 by inserting copper/ferrite inductor close to them while watching curve on oscilloscope. Curve should decrease in height with either ferrite (same as increasing inductance, i.e. more core) or with copper (same as decreasing inductance, i.e. extend size of coil). If curve increases in size more than 10% adjust only the coil which reacts incorrectly. Adjust coils by gently extend or contract the aircoil with a non-metallic and non-static tool (i.e. plastic knit-pin or a wooden stick). Be careful not to deform coil.
4. Set tuner to 105MHz, enter into preset 2, and tune generator so that curve appears on oscilloscope.
5. Check L 2 - L 4 - L 5 again with the ferrite/copper inductor. Curve should not increase more than 10% on any of the coils.
6. Repeat step 2 + 3 + 4 + 5 if curve height is outside of tolerances, if necessary distribute the error between 90 and 105 MHz. Check tuning voltage again if tolerances not possible to achieve.

C. IF ADJUSTMENT

1. Set tuner to approximately 98 MHz (the tuner must be tuned to an unoccupied frequency) enter into preset 3, and tune FM generator to display a curve on the oscilloscope.
2. Adjust I 1 (IFT tuner frontend) to maximum and symmetrical curve on the display, using as little input signal as possible.

D. DETECTOR COARSE ADJUSTMENT (OPTIONAL, NEEDED ONLY IF DETECTOR WAS REPAIRED).

1. Reduce sweep modulation level to +/- 75 kHz and set input level to 300 uv.
2. Adjust FM generator frequency so that both legs of the inverted U-shaped curve are equally high on the display. The curve should be almost perfectly symmetrical.
3. Disconnect detectorprobe from tuner and oscilloscope. Connect either of the tape rec. outputs to the oscilloscope.
4. Adjust I 102 primary (closest to the rear of unit) to maximum curveheight and I 103 secondary (closest to the front of unit) to minimum curveheight and straightest possible line. Go back and forth between primary and secondary till both are peaked.

NOTE: Both the cores should be within 1.5 mm from the top of the form.

E. DETECTOR ALIGNMENTS (FINAL)

1. Disconnect detectorprobe and connect tape rec. outputs to VTVM's, oscilloscope and distortion analyzer.
2. Switch stereo generator to 1 kHz 100%(+/- 75kHz) mono modulation and oscilloscope to normal internal sweep 0.2 mS and 0.5 V/cm sensitivity.
3. Detector reference frequency
Reduce FM generator output level while monitoring THD from left channel. When THD increases to 3%, fine tune the FM generator frequency to minimum THD. Reduce FM generator output level and fine tune till no reduction in the 3% THD can be achieved by fine tuning. Use this frequency for all the following detector, MPX and FM NR adjustments.

NOTE: The typical input level for this 3% THD should be 1.6 uv to 2.3 uv. This is done only to "lineup" the frequency from the generator to the tuner's frequency. If IHF usable sensitivity (-30 dB THD+N= 3.16% THD+N) is to be verified, a proper IHF bandpassfilter must be used.

4. Connect DMM ACROSS P112 (negative) and P113 (positive). Set FM generator output level to 1000 uV.
5. Adjust I 102 primary (closest to the rear of unit) for 0 V on DMM.
TOLERANCE +/- 50 mV
6. Adjust I 103 secondary (closest to the front of unit) for lowest THD.
SPECIFICATION less than 0.1%.
7. Repeat steps 5 - 7 till no further improvements. Record the DMM's final reading for use later in the adjustment.

F. AUTOSEARCH LEVEL

1. Connect DMM between 117 and ground.
2. Increase FM generator level SET TO 10 uV and adjust R117 so that DMM reading goes from 8.5 V to approximately 0.55 V at 10 uV.
TOLERANCE +/-0.15v

G. STEREO DECODER, MPX FILTERS.

1. VCO
Connect a frequency counter between IC 6 pin 11 and ground.
2. Set FM generator to 1000 uv output and no modulation.
3. Adjust VR 3 for a 19000 Hz reading on the counter.
TOLERANCE +/- 100Hz
4. Disconnect frequency counter and press FM NR. defeat switch (in).
5. Stereo switch threshold.
Modulate FM generator 1 kHz 45% left only plus 19 kHz PILOT 8 - 10%.
6. Increase FM generator level upwards from 0 and adjust VR 2 so that stereo light turns on and audio outputs as watched on VTVM and oscilloscope, switches to one channel only at 10 uv input level.
TOLERANCE +5 uV

NOTE: When turning input level down the unit will switch into mono at a lower level, typically 5 - 7 uV.

7. Stereo separation
Set FM generator output to 1000 uv, modulate in mono only.
8. Adjust VR 4 for identical outputs in the two channels.
TOLERANCE +/- 20mV.
9. Modulate FM generator left channel only and adjust VR 5 for minimum on right channel VTVM.
10. Modulate FM generator right channel only and adjust VR 5 for minimum on left channel VTVM.
11. If the minimum in step 9 and 10 are different, adjust VR 5 so that the readings are the same in both channels.
SPECIFICATION better than 40dB separation
12. MPX filter
Turn off audiomodulation, leaving pilot tone only. Disable IHF filter or external 19 kHz filter if used.
13. Adjust LPF 1 left channel and LPF 2 right channel for minimum output
SPECIFICATION more than 60 dB suppression

AM ALIGNMENTS

Unless repairs have been done to Oscillator Section, do not adjust AM OSC coil or Trimming Capacitor. If OSC Adjustment is needed, connect high impedance voltmeter (preferably DMM) between P123 and ground.

A. OSC ADJUSTMENT

1. Tune unit to show 600KHz on display and adjust L102 to read 1.75V±0.05V on DMM.

B. IF ADJUSTMENT

1. For IF adjustment and Tracking adjustment connect VTVM to loudspeaker output (or tape output), only one channel connection needed, and connect signal generator to antenna terminals. Adjust generator for 30% modulation and approx. 1u0 uv input.
Tune both generator and receiver to approx. 1000KHz, and adjust generator frequency for maximum reading on VTVM. Then adjust IFT2, and IFT3 for maximum reading on meter.

C. TRACKING ADJUSTMENT

1. Tune unit and generator to show approx. 600KHz and adjust L101 to maximum reading on VTVM.
2. Tune unit and generator to show approx. 1400KHz and adjust C138 (Trimming Capacitor) for maximum reading on VTVM.
3. Repeat step 1 and 2 until no further improvement.

TUNER ADJUSTMENT POINTS

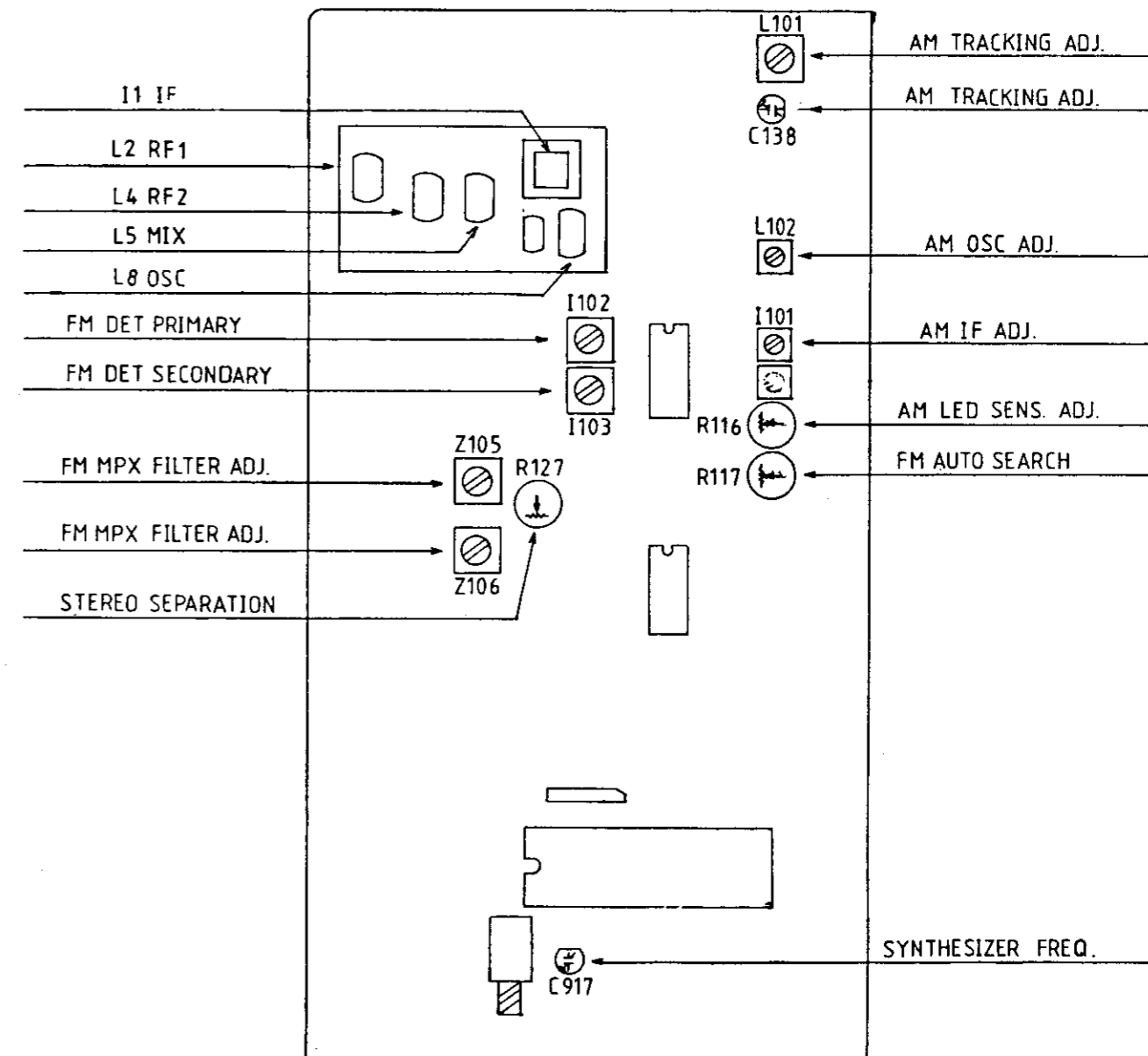

AMPLIFIER PCB LAYOUT AND WIRING DIAGRAM

For versions A, A1.

For versions B, B1, C, C1.

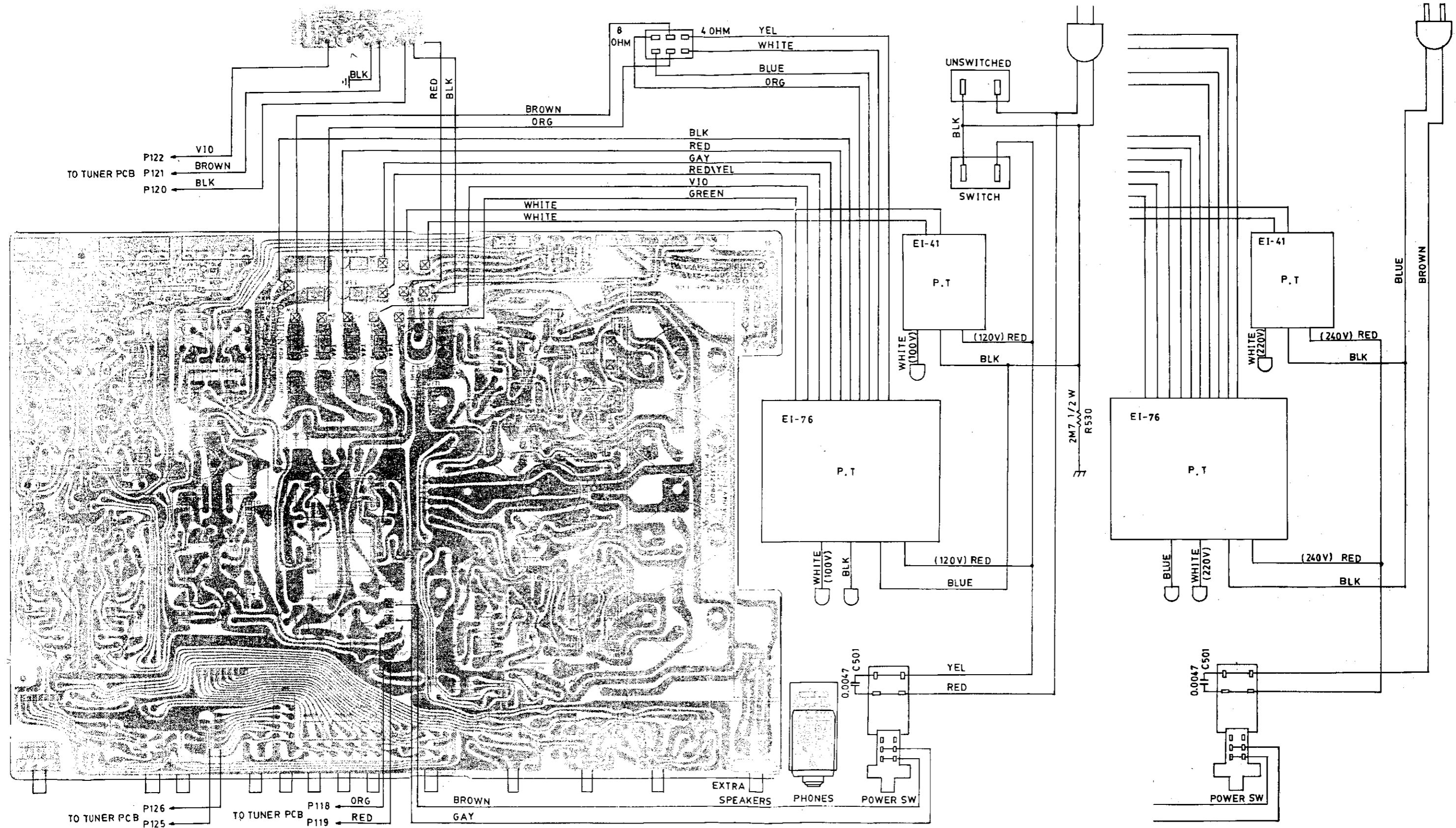

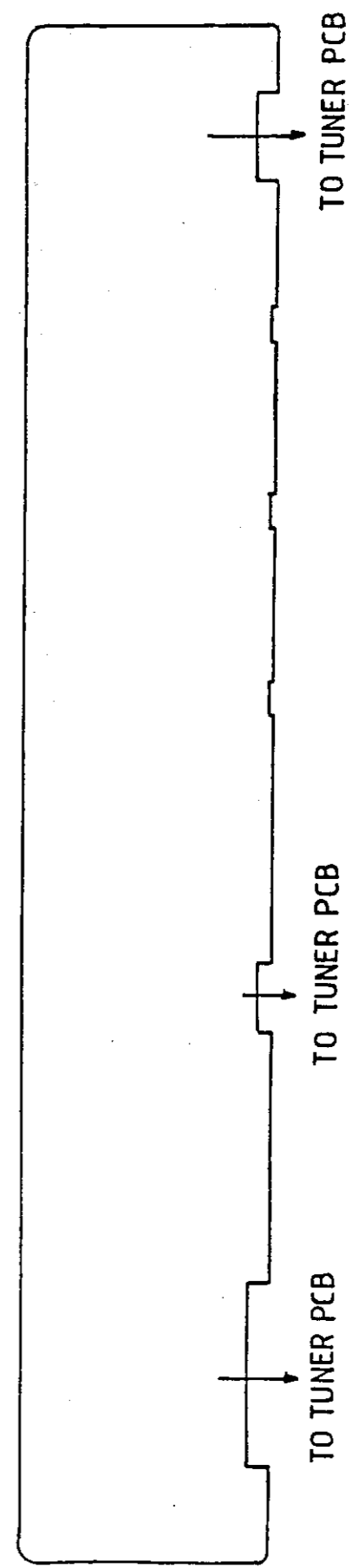
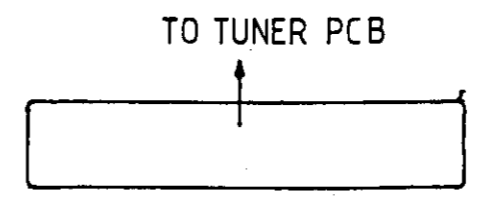
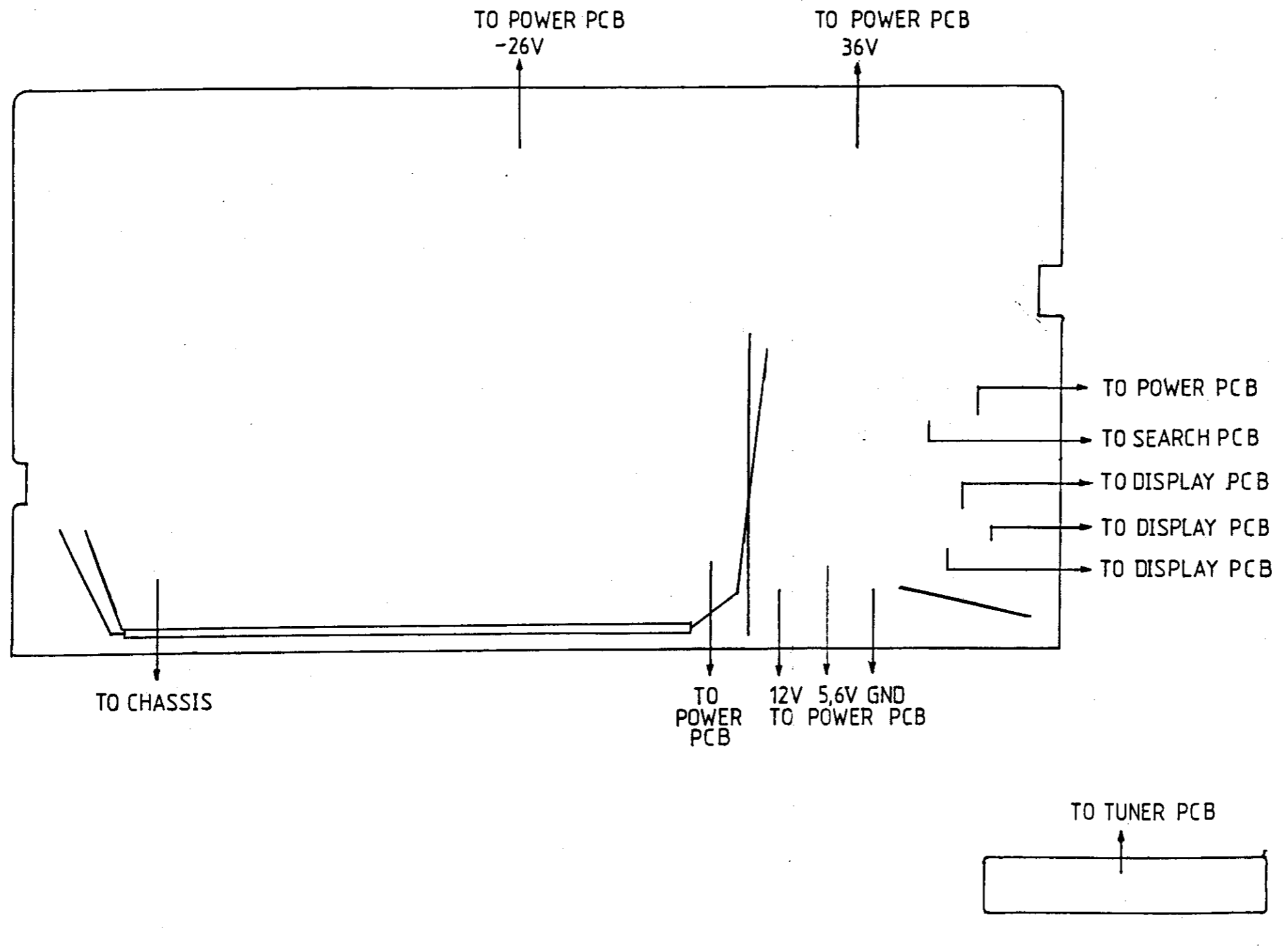

AMPLIFIER PCB LAYOUT

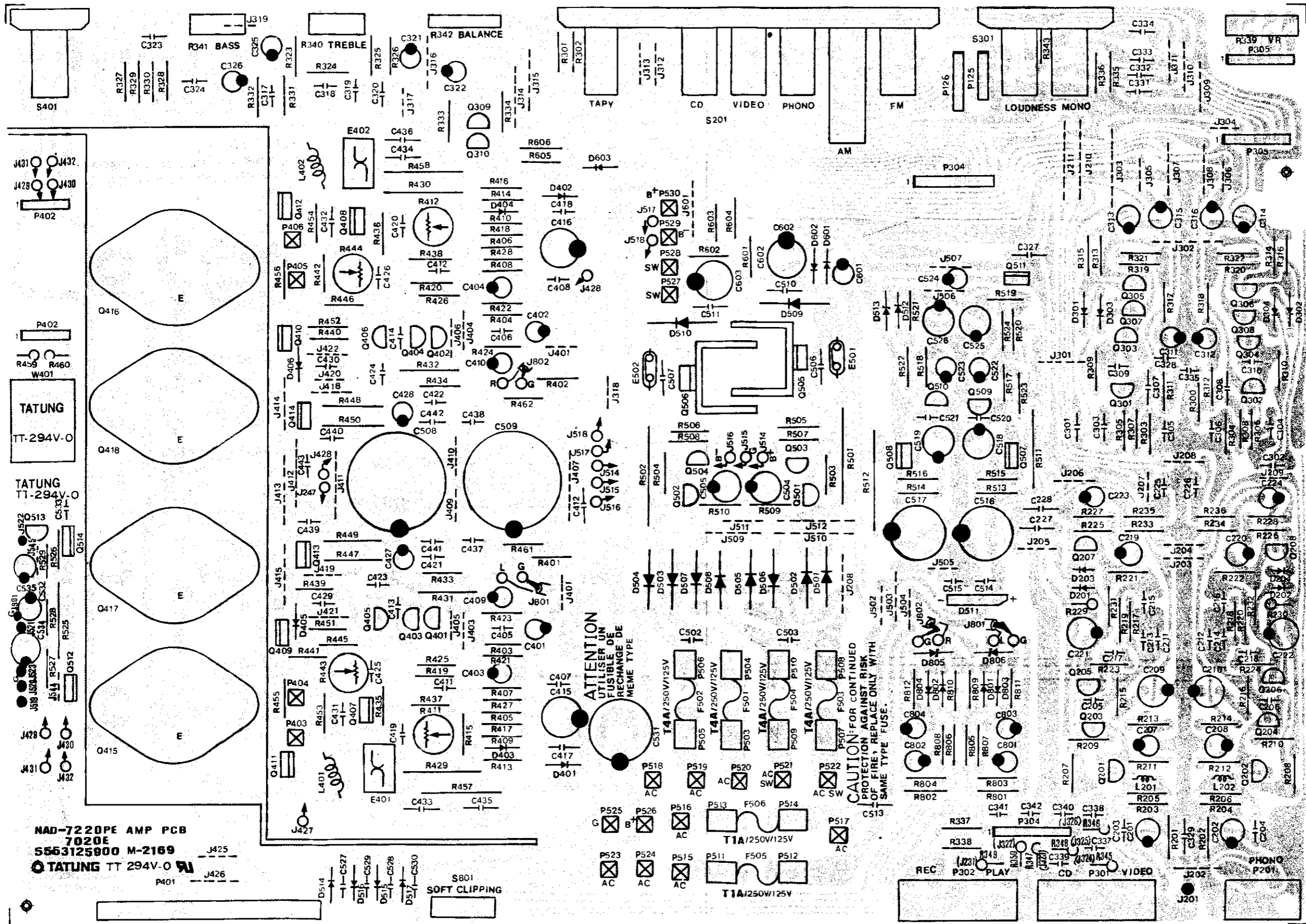

NAD-7220PE AMP PCB
7020E
5553125900 M-2169
TATUNG TT 294V.0

ATTENTION
UTILISER UN
FUSIBLE DE
RECHANGE DE
MEME TYPE

CAUTION FOR CONTINUED
PROTECTION AGAINST RISK
OF FIRE, REPLACE ONLY WITH
SAME TYPE FUSE.

SCHMATIC DIAGRAM NAD7220PE AMPLIFIER

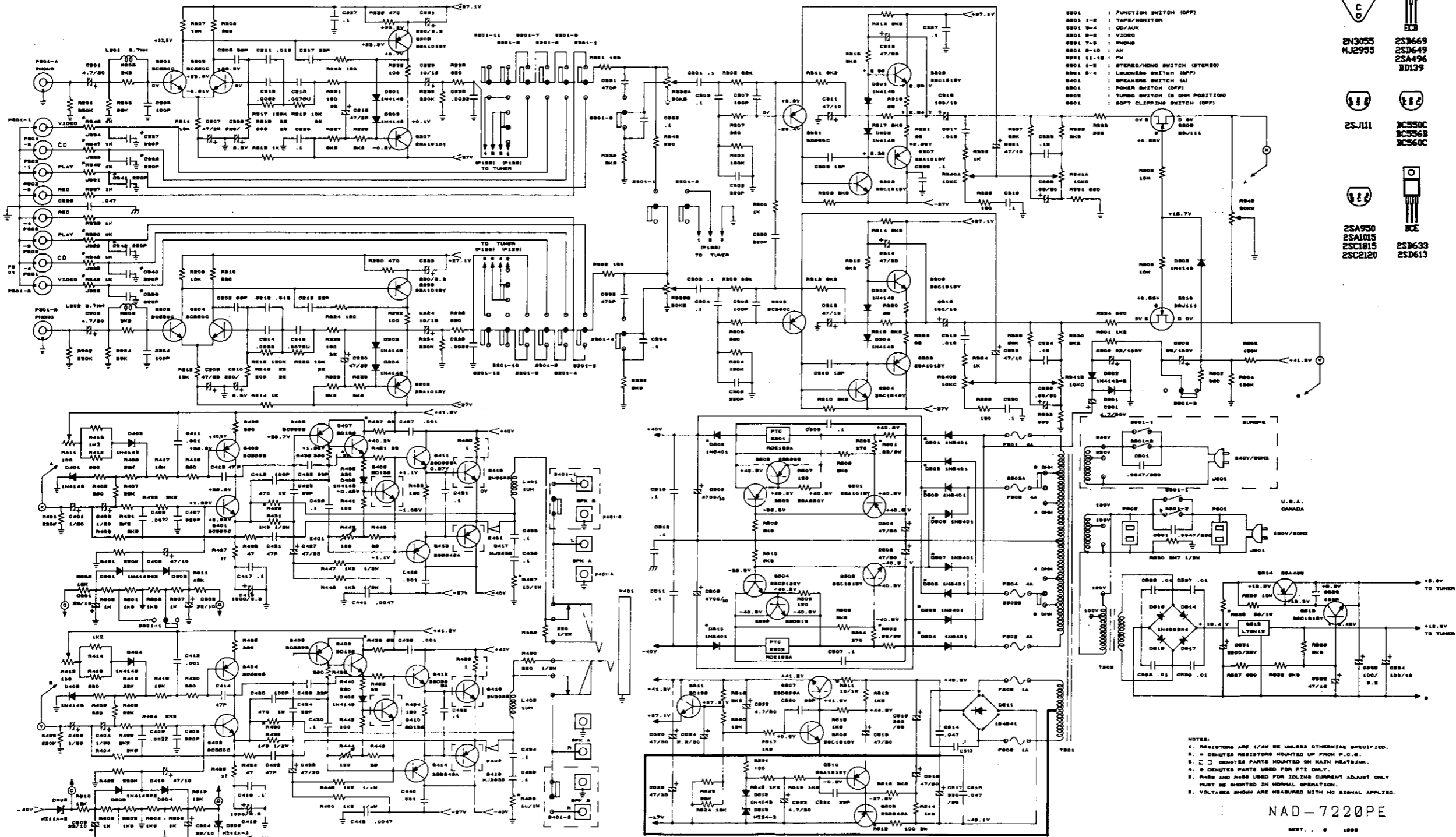

NOTES:
 1. RESISTORS ARE 1/4W UNLESS OTHERWISE SPECIFIED.
 2. W DENOTES RESISTORS MOUNTED UP FROM P.C.B.
 3. C DENOTES PARTS MOUNTED ON MAIN HEATSHIELD.
 4. R DENOTES PARTS USED FOR P.T.D. ONLY.
 5. R488 AND R489 USED FOR IDLING CURRENT ADJUST ONLY. MUST BE SHORTED IN NORMAL OPERATION.
 6. VOLTAGES SHOWN ARE MEASURED WITH NO SIGNAL APPLIED.

NAD-7220PE
 SEPT. 1988

AMPLIFIER PCB LAYOUT

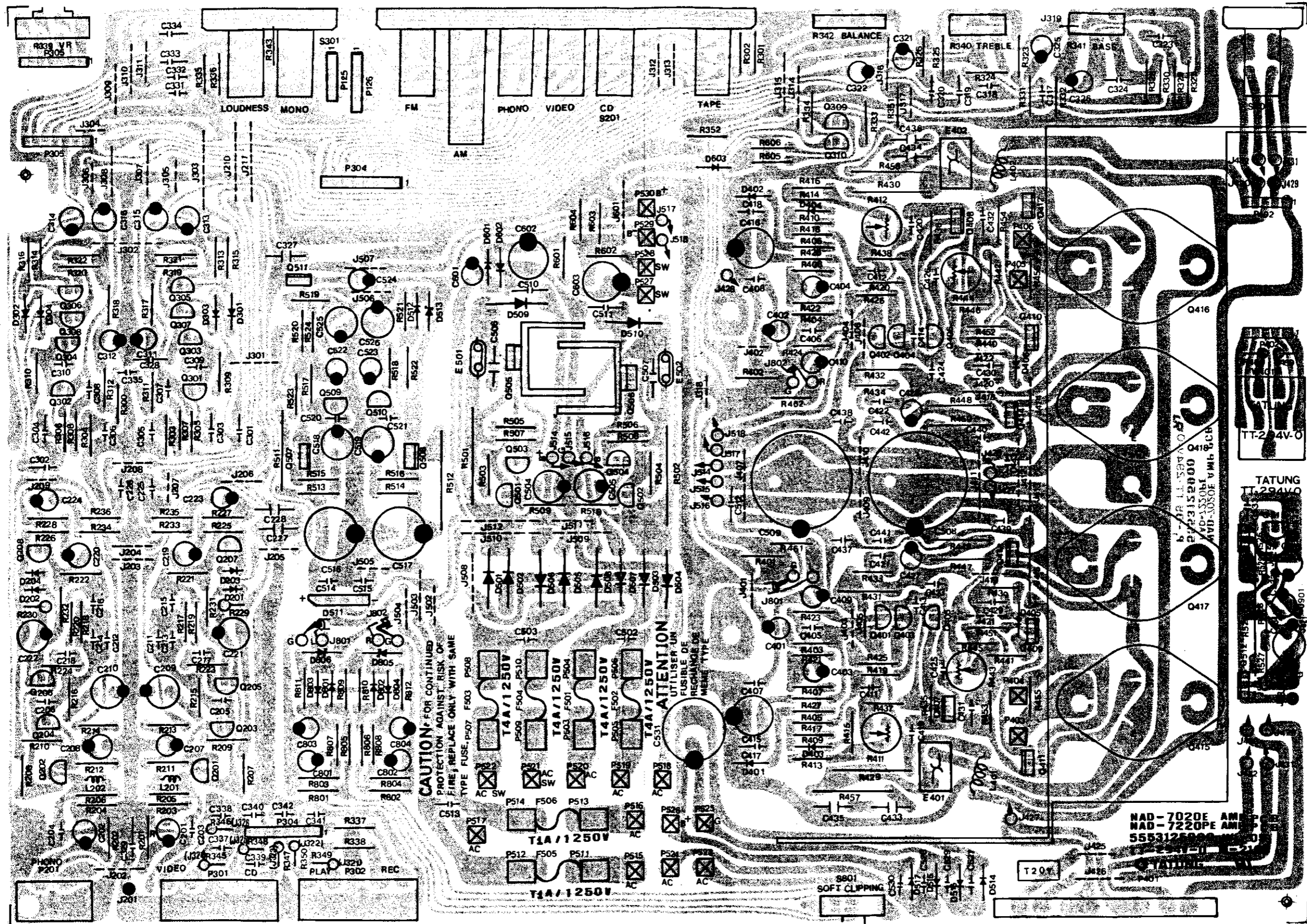

SCHMATIC DIAGRAM NAD7020E AMPLIFIER

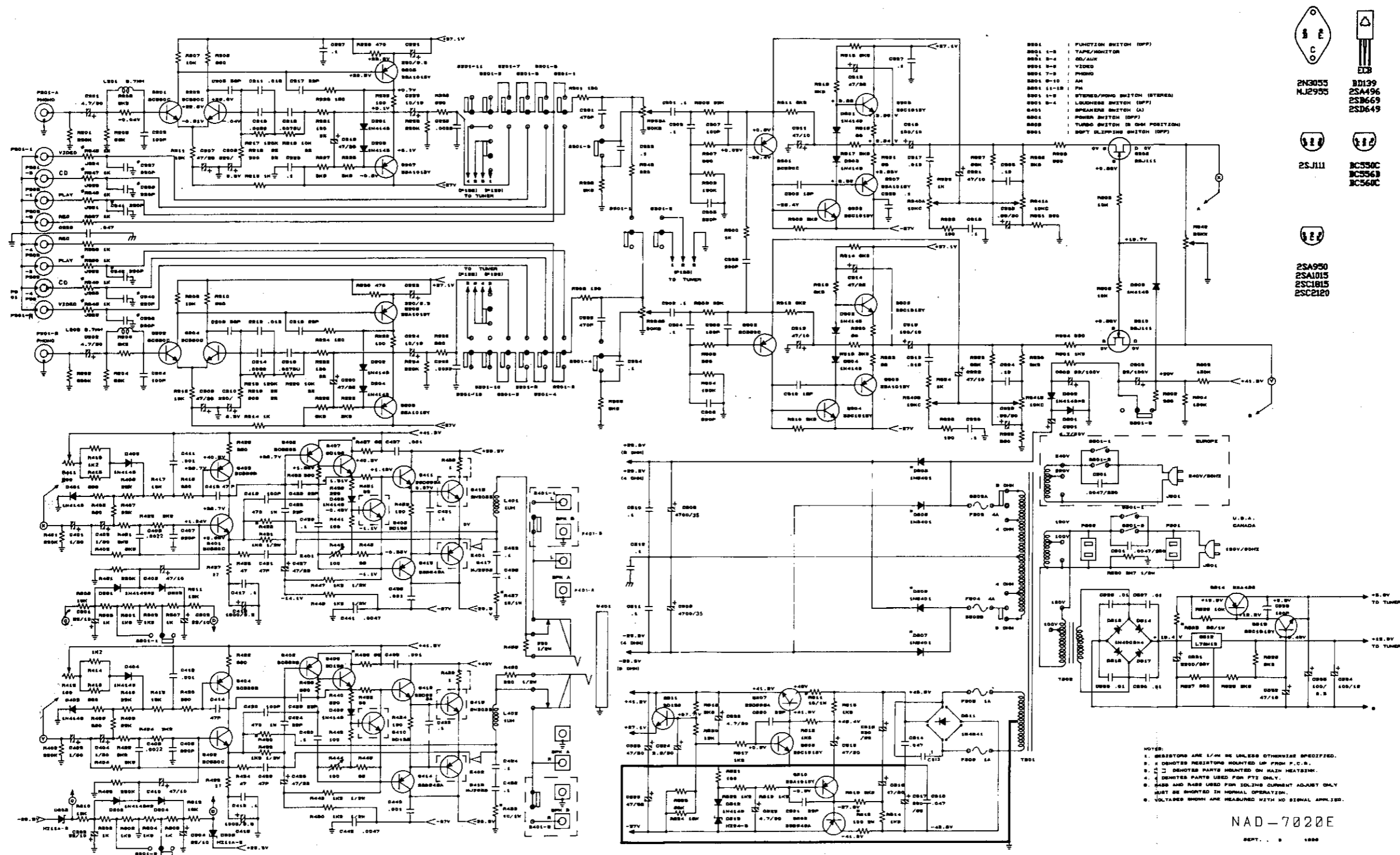

TUNER PCB LAYOUT

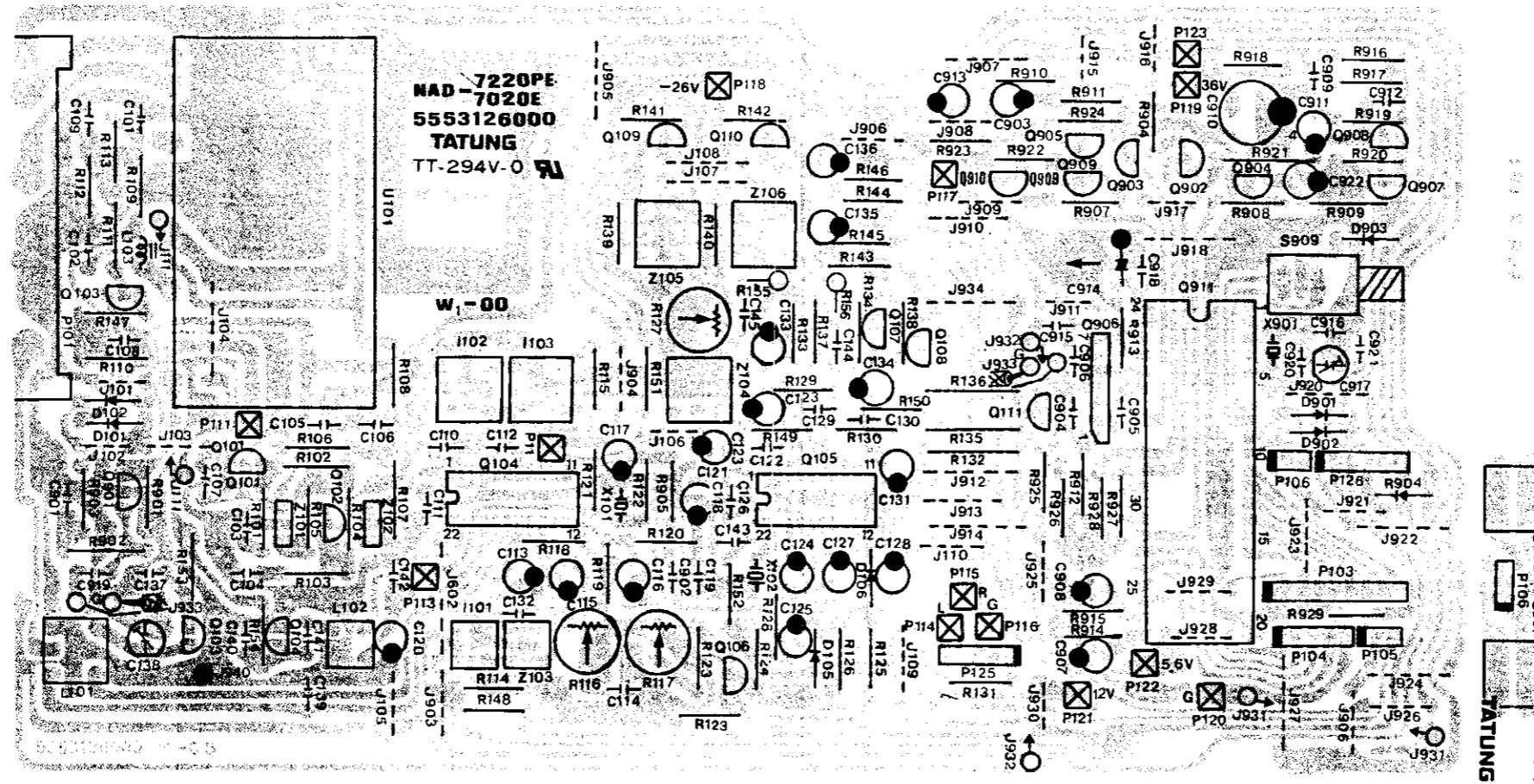

Display, PCB Layout

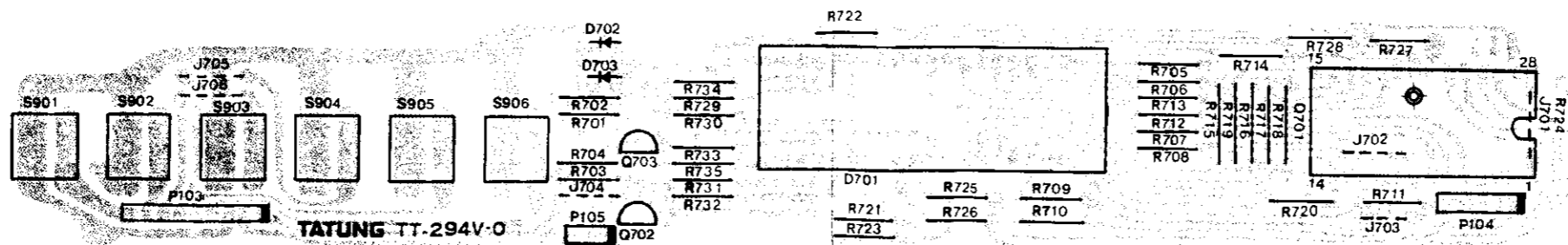

NAD-7220PE
7020e TUNER CIRCUIT DIAGRAM
AUG-06, 1986
NOV-27.

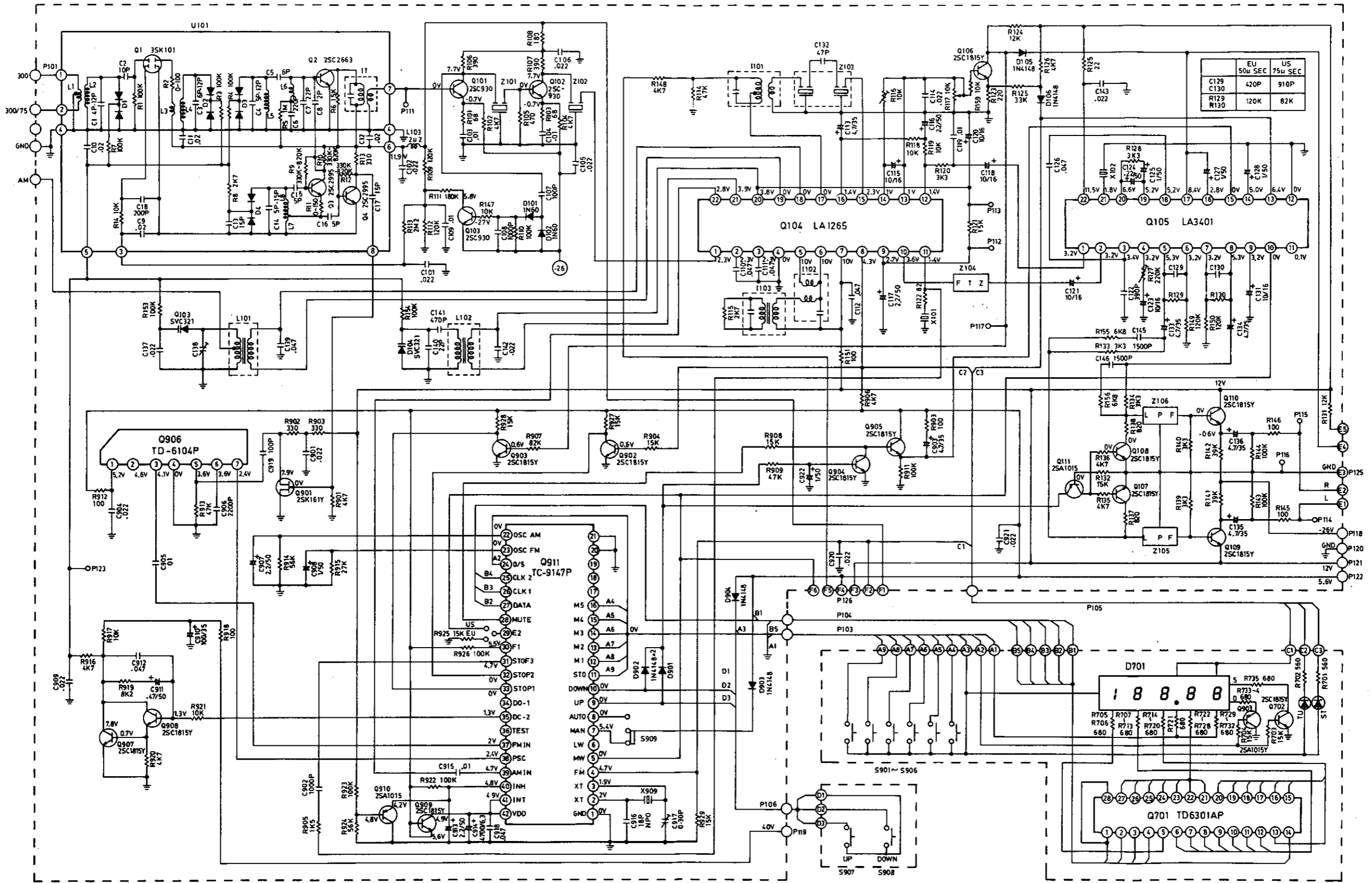

7220PE / 7020e PART LIST

SYMBOL NO	PART NO	DESCRIPTION	REF
D701	5551206600	LED DISPLAY	
D702	6618009400	LED	
D703	6618010900	LED	
Q701	6645017800	IC. TD6301A	
Q702	6621015332	TR, 25C1815-Y	
Q703	6623002050	TR, 25A1015-Y	
R701 R702	5142856190	RES. CARB 560	+5% 1/4W
R703 R704	5142815390	RES. CARB 15K	+5% 1/4W
R705 R706	5142868190	RES. CARB 680	+5% 1/4W
R707 R708	5142868190	RES. CARB 680	+5% 1/4W
R709 R710	5142868190	RES. CARB 680	+5% 1/4W
R711 R712	5142868190	RES. CARB 680	+5% 1/4W
R713 R714	5142868190	RES. CARB 680	+5% 1/4W
R715 R716	5142868190	RES. CARB 680	+5% 1/4W
R717 R718	5142868190	RES. CARB 680	+5% 1/4W
R719 R720	5142868190	RES. CARB 680	+5% 1/4W
R721 R722	5142868190	RES. CARB 680	+5% 1/4W
R723 R724	5142868190	RES. CARB 680	+5% 1/4W
R725 R726	5142868190	RES. CARB 680	+5% 1/4W
R727 R728	5142868190	RES. CARB 680	+5% 1/4W
R729 R730	5142868190	RES. CARB 680	+5% 1/4W
R731 R732	5142868190	RES. CARB 680	+5% 1/4W
R733 R734	5142868190	RES. CARB 680	+5% 1/4W
R735	5142868190	RES. CARB 680	+5% 1/4W
S901 S902	5554117900	SW TACT	
S903 S904	5554117900	SW TACT	
S905 S906	5554117900	SW TACT	
S907 S908	5554117900	SW TACT	
C101 C102	5231822391	CAP. CER. 22000PF	+80-20% 50V
C103 C104	5231810391	CAP. CER. 10000PF	+80-20% 50V
C105 C106	5231822391	CAP. CER. 22000PF	+80-20% 50V
C107	5247010191	CAP. CER. 100PF	+5% 50V
C108	5231510291	CAP. CER. 1000PF	+20% 50V
C109	5231810391	CAP. CER. 10000PF	+80-20% 50V
C110 C111	5231847391	CAP. CER. 7000PF	+80-20% 50V
C112	5231847391	CAP. CER. 7000PF	+80-20% 50V
C113	5213647991	CAP. CER. 4.7MF	50V
C114	5231822391	CAP. CER. 22000PF	+80-20% 50V
C115 C118	5213310091	CAPE. CER. 10MFT	16V
C116	5213622991	CAPE. CER. 2.2MF	50V
C117	5213622912	CAPE. CER. 2.2MFU	50V
C119	5231810391	CAPE. CER. 10000PF	+80-20% 50V
C120 C123	5213310091	CAPE. CER. 10MFT	16V
C121	5213310012	CAPE. CER. 10MFT	16V
C122	5247139191	CAPE. CER. 390F	+10% 50V
C124	5215000491	CAPE. CER. .22MF	+20% 50V
C125	5213601091	CAP. CER. 1MF	50V
C126	522247301	CAPE. CER. 470000PF	+10% 50V
C127 C128	5213601091	CAP. CER. 1MF	50V
C129 C130	5225191100	CAP. CER. 901PF	+5%
C131	5213310091	CAP. CER. 10MFT	16V
C132	524247091	CAP. CER. 47PF	+5% 50V
C133 C134	5213647991	CAP. CER. 4.7MF	50V

Q904 Q905	6621015332	TR.	25C1815-Y
Q906	6645017700	IC.	TD6104P
Q907 Q908	6621015332	TR.	25C1815-Y
Q909	6621015332	TR.	25C1815-Y
Q910	6623002050	TR.	25A1015-Y
Q911	6645017600	IC.	TC9147P
R101	5142868090	RES. CARB	68
R102 R104	5142847290	RES. CARB	4.7K
R103	5142868090	RES. CARB	68
R105	5142847290	RES. CARB	470
R106 R107	5142839190	RES. CARB	390
R108	5142818190	RES. CARB	180
R109	5142812490	RES. CARB	120K
R110	5142810490	RES. CARB	100K
R111	5142818490	RES. CARB	180K
R112	5142812490	RES. CARB	120K
R113	5142822590	RES. CARB	2.2M
R114	5142847390	RES. CARB	47K
R115	5142827290	RES. CARB	2.7K
R116 R117	5162310320	RES. VR	1/8W
R118 R119	5142810390	RES. CARB	10K
R120	5142833290	RES. CARB	3.3K
R121	5142815390	RES. CARB	15K
R122	5142882090	RES. CARB	82
R123	5142822190	RES. CARB	220
R124	5142812390	RES. CARB	12K
R125	5142833390	RES. CARB	33K
R126	5142847290	RES. CARB	4.7K
R127	5162322420	RES. VR	220K
R128	5142833290	RES. CARB	3.3K
R129 R130	5142882390	RES. CARB	82K
R131	5142812390	RES. CARB	12K
R132	5142815390	RES. CARB	15K
R133 R134	5142833290	RES. CARB	3.3K
R135 R136	5142847290	RES. CARB	4.7K
R137 R138	5142882190	RES. CARB	820
R139 R140	5142833290	RES. CARB	3.3K
R141 R142	5142839390	RES. CARB	39K
R143 R144	5142810490	RES. CARB	100K
R145 R146	5142810190	RES. CARB	100
R147	5142810390	RES. CARB	100K
R148	5142847290	RES. CARB	4.7K
R149 R150	5142812490	RES. CARB	120K
R151	5142810190	RES. CARB	100
R152	5142822090	RES. CARB	22
R153 R154	5142810490	RES. CARB	100K
R155 R156	5145868206	RES. CARB	6.8K
R159	5142810390	RES. CARB	10K
R901	5142847290	RES. CARB	4.7K
R902 R903	5142833190	RES. CARB	330
R904	5142815301	RES. CARB	15K
R905	5142815290	RES. CARB	1.5K
R906	5142847290	RES. CARB	4.7K
R907	5142882390	RES. CARB	82K
R908	5142815390	RES. CARB	15K
R909	5142847390	RES. CARB	47K
R910 R912	5142810190	RES. CARB	100
R911	5142810490	RES. CARB	100K
R913	5142847390	RES. CARB	47K
R914	5142856301	RES. CARB	56K

C135 C136	5213647991	CAP. CER.	4.7MF	50V
C137	5231822391	CAP. CER.	22000PF	+80-20% 50V
C138	5552402900	TRIMER	300F	T203R
C139	5231847391	CAP. CER.	47000PF	+80-20% 50V
C140	5242222091	CAP. CER.	22PF	+5% 50V
C141	5226147100	CAP. POLY	470PF	+5% 50V
C142 C143	5231822391	CAP. CER.	22000PF	+80-20% 50V
C145 C146	5231515201	CAP. CER.	1500PF	+20% 50V
C901	5231822391	CAP. CER.	22000PF	+80-20% 50V
C902	5231510291	CAP. CER.	1000PF	+20% 50V
C903	5213647991	CAP. EL.	4.7MF	50V
C904	5231822391	CAP. CER.	22000PF	+80-20% 50V
C905	5231810391	CAP. CER.	10000PF	+80-20% 50V
C906	5231522291	CAP. CER.	2200PF	+20% 50V
C907	5213622991	CAP. EL.	2.2MF	50V
C908	5213601091	CAP. EL.	1MF	50V
C909	5231822391	CAP. CER.	22000PF	+80-20% 50V
C910	5213510112	CAP. EL.	100MFT	35V
C911	5213647891	CAP. EL.	0.47MFU	50V
C912	5231847391	CAP. CER.	47000PF	+80-20% 50V
C913	5213622991	CAP. EL.	2.2MF	50V
C914	5215001201	CAP. EL.	4700MFM	6.3V
C915	5231810391	CAP. CER.	10000PF	+80-20% 50V
C916	5242218091	CAP. CER.	18PF	+5% 50V
C917	5552402900	TRIMMER	300F	T203R
C918	5231847391	CAP. CER.	47000PF	+80-20% 50V
C919	5247010191	CAP. CER.	100PF	+5% 50V
C920 C921	5231822391	CAP. CER.	22000PF	+80-20% 50V
C922	5213601091	CAP. EL.	1MF	50V
D101 D102	6612004001	DIODE.	1N60	
D103 D104	6614004900	DIODE.	5VC3214	
D105 D106	6613003030	DIODE	1N4148	
D901 D902	6613003030	DIODE	1N4148	
D903 D904	6613003030	DIODE	1N4148	
I101	5565105200	AM IFT	2150-384-W142	
I102	5565204300	FM DET-1	0204-384-W008	
I103	5565204400	FM DET-2	0204-384-W009	
P101	5556204410	TEERMINAL		
P102	5553126000	TUNER PCB		
P103	5556900820	PVC WIRE	PARALLE	9P
P104	5556900450	PVC WIRE	PARALLE	5P
P105 P106	5556900200	PVC WIRE	PARALLE	3P
P111	5556201900	PIN		
P112 P113	5556201900	PIN		
P114 P115	5556201900	PIN		
P116 P117	5556201900	PIN		
P118 P119	5556201900	PIN		
P120 P121	5556201900	PIN		
P122 P123	5556201900	PIN		
P130	5556200800	LUG		
Q101 Q102	6621012101	TR.	25C930E	
Q103	6621012101	TR.	25C930E	
Q104	6644055700	IC	LA1265	
Q105	6644055800	IC	LA3401	
Q106 Q107	6621015332	TR.	25C1815-Y	
Q108 Q109	6621015332	TR.	25C1815-Y	
Q110	6621015332	TR.	25C1815-Y	
Q111	6623002050	TR.	25A1015-Y	
Q901	6625001301	TR.	25K161-Y	
Q902 Q903	6621015332	TR.	25C1815-Y	

D603D801	6613003030	DIODE	1N4148	
D802 D803	6613003030	DIODE	1N4148	
D804	6613003030	DIODE	1N4148	
D806	6615007900	D100	HZ-11A-2	
E401 E402	5554432210	BREAKER	A-35	3.5A
E501 E502	5554432500	PTC SW	RDE185A	
F501 F502	5554309800	FUSE	125V/4A	UL/CSA
F503 F504	5554309800	FUSE	125V/4A	UL/CSA
F505 F506	5554309810	FUSE	125V/1A	UL/CSA

R915	5142827390	RES. CARB	27K	+5% 1/4W		E403 C404	5213601091	CAP. EL	1MF	50V
R916	5142847290	RES. CARB	4.7K	+5% 1/4W		C405 C406	5222122291	CAP. POLY	2200PF	+5% 50V
R917	5142810390	RES. CARB	10K	+5% 1/4W		C407 C408	5231382101	CAP. CER	820PF	+10% 50V
R918	5142810190	RES. CARB	100	+5% 1/4W		C409 C410	5213247091	CAP. EL.	47MFT	10V
R919	5142882290	RES. CARB	8.2K	+5% 1/4W		C411 C412	5222110291	CAP. POLY	1000PF	+5% 50V
R920	5142847290	RES. CARB	4.7K	+5% 1/4W		C413 C414	5247047091	CAP. CER	47PF	+5% 50V
R921	5142810390	RES. CARB	10K	+5% 1/4W		C415 C416	5213110212	CAP. EL.	1000MFT	6.3V
R922 R923	5142810490	RES. CARB	100K	+5% 1/4W		C417 C418	5222110491	CAP. POLY	0.1MF	+5% 50V
R924	5142856390	RES. CARB	56K	+5% 1/4W		C419 C420	5247010191	CAP. CER	100PF	+5% 50V
R926	5142810490	RES. CARB	100K	+5% 1/4W		C421 C422	5247047091	CAP. CER	47PF	+5% 50V
R927 R928	5142815390	RES. CARB	15K	+5% 1/4W		C423 C424	5247022091	CAP. CER	22PF	+5% 50V
R929	5142815390	RES. CARB	15K	+5% 1/4W		C425 C426	5247022091	CAP. CER	22PF	+5% 50V
S909	5554430400	SW	PUSH			C427 C428	5213447091	CAP. EL.	47MFT	25V
R459 R460	5145422106	RES. CARB	220	+5% 1/2W		C429 C430	5222110491	CAP. POLY	0.1MF	+5% 50V
W401		JACK	PHONE			C431 C432	5222110491	CAP. POLY	Q.1MF	+5% 50V
R339	5169020291	RES. VR	50KB42			C433 C434	5231810401	CAP. CER	0.1MF	+80-20% 50V
C532	5213347091	CAP. EL.	47MFT	16V		C435 C436	5231810401	CAP. CER	0.1MF	+80-20% 50V
C533	5247010101	CAP. CER	100PF	+5% 50V		C437 C438	5231510291	CAP. CER	1000PF	+20% 50V
C534	5213310112	CAP. EL.	100MFT	16V		C439 C440	5231510291	CAP. CER	1000PF	+20% 50V
C535	5213110112	CAP. EL.	100MFT	6.3V		C441 C442	5231547291	CAP. CER	4700PF	+20% 50V
Q512	6640003000	IC	L78N12	12V		C443	5231847381	CAP. CER	47000PF	+80-20% 50V
Q513	6621015332	TR.	25C1815-Y			C504 C505	5213647012	CAP. EL.	47MFT	50V
Q514	6623000401	TR.	25A496-Y			C506 C507	5231810401	CAP. CER	0.1MF	+80-20% 50V
R525	5133256007	RES.	56	+5% 1W		C508 C509	5210701601	CAP. EL.	4700MFT	50V
R526	5142810390	REES. CARB	10K	+5% 1/4W		C510 C511	5231810401	CAP. CER	0.1MF	+80-20% 50V
R527	5142868190	RES. CARB	680	+5% 1/4W		C512	5231810401	CAP. CER	0.1MF	+80-20% 50V
R528 R529	5142868290	RES. CARB	6.8K	+5% 1/4W		C513	5222210401	CAP. POLY	.1MF	+10% 50V
C201 C202	5213647991	CAP. EL.	4.7MF	50V		C514 C515	5231847391	CAP. CER	47000PF	+80-20% 50V
C203 C204	5247010191	CAP. CER	100PF	+5% 50V		C516 C517	5213733112	CAP. EL.	330MFT	63V
C205 C206	5247056091	CAP. CER	56PF	+5% 50V		C518 C519	5213647091	CAP. EL.	47MFT	50V
C207 C208	5213447091	CAP. EL.	47MFT	25V		C520 C521	5247022091	CAP. CER	22PF	+5% 50V
C209 C210	5213122191	CAP. L.	220MFT	6.3V		C522 C523	5213647991	CAP. EL.	4.7MF	50V
C211 C212	5222118391	CAP. POLY	18000PF	+5% 50V		C524	5213622991	CAP. EL.	2.2MF	50V
C213 C214	5222182291	CAP. POLY	8200PF	+5% 50V		C525	5213647091	CAP. EL.	47MFT	50V
C215 C216	5222175291	CAP. POLY	7500PF	+5% 50V		C526	5213547012	CAP. EL.	47MFT	35V
C217 C218	5247027091	CAP. CER	27PF	+5% 50V		C527 C528	5231810391	CAP. CR	10000PF	+80-20% 50V
C219 C220	5213447091	CAP. EL.	47MFT	25V		C529 C530	5231810391	CAP. CR	10000PF	+80-20% 50V
C221 C222	5213122191	CAP. EL.	220MFT	6.3V		C531	5213422212	CAP. EL.	2200MFT	25V
C223 C224	5213310091	CAP. EL.	10MFT	16V		C601	5213647991	CAP. EL.	4.7MF	50V
C225 C226	5222122291	CAP. POLY	2200PF	50V		C602 C603	5214122012	CAP. EL.	22MFT	100V
C227 C228	5231810401	CAP. CER	0.1MF	+80-20% 50V		C801 C802	5213222901	CAP. EL.	22MFT	10V
C301 C302	5222110491	CAP. POLY	0.1MF	+5% 50V		C803 C804	5213222901	CAP. EL.	22MFT	10V
C303 C304	5222110491	CAP. POLY	0.1MF	+5% 50V		D201 D202	6613003000	DIODE	1N4148	
C305 C306	5247122191	CAP. CER	220PF	+10% 50V		D203 D204	6613003000	DIODE	1N4148	
C307 C308	5247010191	CAP. CER	100PF	+5% 50V		D301 D302	6613003030	DIODE	1N4148	
C309 C310	5247015001	CAP. CER	15PF	+5% 50V		D303 D304	6613003030	DIODE	1N4148	
C311 C312	5213247091	CAP. EL.	47MFT	10V		D401 D402	6613003030	DIODE	1N4148	
C313 C314	5213447091	CAP. EL.	47MFT	25V		D403 D404	6613003030	DIODE	1N4148	
C315 C316	5213210191	CAP. EL.	100MFT	10V		D405 D406	6613003030	DIODE	1N4148	
C317 C318	5222118391	CAP. POLY	18000PF	+5% 50V		D501 D502	6611000800	DIODE	1N5401	
C319 C320	5222110491	CAP. POLY	0.10MF	+5% 50V		D503 D504	6611000800	DIODE	1N5401	
C321 C322	5213247091	CAP. EL.	47MFT	10V		D505 D506	6611000800	DIODE	1N5401	
C323 C324	5222112401	CAP. POLY	.12MF	+5% 50V		D507 D508	6611000800	DIODE	1N5401	
C325 C326	5215001301	CAP. EL.	0.68MF	+10% 50V		D509 D510	6611000800	DIODE	1N5401	
C327 C328	5231810401	CAP. CER	0.1MF	+80-20% 50V		D511	6611012400	DIODE	1B4841	
C329	5231847391	CAP. CER	47000PF	+80-20% 50V		D512	6613003030	DIODE	1N4148	
C331 C332	5247147101	CAP. CER	470PF	+10% 50V		D513	6615016100	DI ZEN		
C333 C334	5222110491	CAP. POLY	0.1MF	+5% 50V		D514 D515	6611007230	DIODE	1N4002	100V
C335	5247122101	CAP. CER	220PF	+10% 50V		D516 D517	6611007230	DIODE	1N4002	100V
C401 C402	5213601012	CAP. EL.	1MF	50V		D601 D602	6613003030	DIODE	1N4148	

NAD- 7220PE PART LIST
7020e

ITEM	PARTS NO.	PARTS NAME	Q'TY
1	5541212400	FRONT, PANEL	1
2	5541002100	TOP, COVER	1
3	5547128700	PLATE, LEFT	1
4	5547128800	PLATE, RIGHT	1
5	5547129000	PLATE, BACK	1
6	5547128200	CHASSIS	1
7	5547128900	PLATE, FRONT	1
8	5561316120	POWER TRANSFORMER	1
9	5545307101	HEAT SINK	1
10	5561316220	POWER TRANSFORMER	1
11	5541534200	ROCKER BUTTON	1
12	5541533900	KNOB, VOLUME	1
13	5541534400	KNOB, PUSH(BLACK)	9
14	5551200600	LED, DISPLAY	1
15	5541534100	KNOB, CONTROL	3
16	5541534410	KNOB, PUSH(GREEN)	1
17	5542908900	LED WINDOW	1
18	5542223200	LED HOLDER	1
19	5542006110	HEMELON(L)	1
20	5542223000	LEVER, CONNECTOR	1
21	5546321200	SPRING, PUSH	1
22	5541534000	KNOB, SEARCH(BLACK)	1
23	5541534500	KNOB, CHASSIS	1
24	5541534010	KNOB, ENTER(BROWN)	1
25	5542006100	HEMELEN(S)	3
26	5547528600	PVC TUBE(BLACK)	1
27	5545306900	HEAT SINK(S)	2
28	5547024210	HEAT SINK(SPCC)	2
29	5545403600	SHIELD COVER	1
30	5542222700	SW, CONNECTOR	1
31	5556308320	AC OUTLET	2
32	5547528400	PLATE, SW. LOCK	1
33	5547501200	BUSHING, POWER CORD	1
34	5556702130	POWER PLUG	1
35	5419700190	HINGE	2
36	5546121400	TERMINAL	1
37	5547128500	BRACKET	1
38	5556204410	ANT. TERMINAL	1
39	5547802100	FOOT	4
40	7190550003	M4X6 MS	4
41	7000311116	M4X6 MS	4
42	7098250002	M4 SPRING WASHER	4
43	7096250006	M4 WASHER	1
44	7034161152	FLT M3X8 TS	3
45	7096160002	M3.5 WASHER	1
46	7033161156	RUD M3X8 TS	22
47	7001171116	PAN M3X8 MS	17
48	7033160652	RUD M3X6 TS	29

EXPLODED VIEW

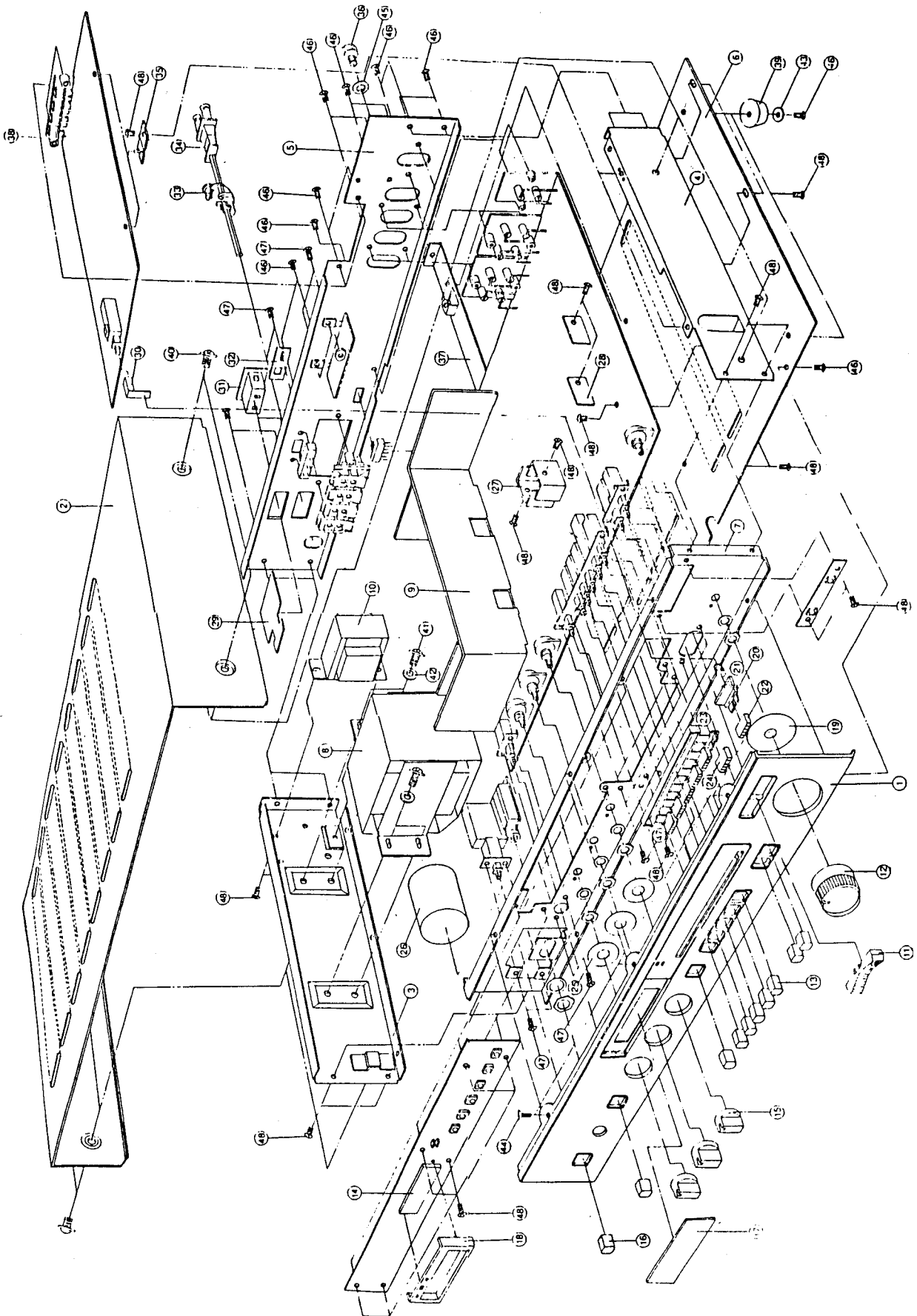

PACKING DIAGRAM

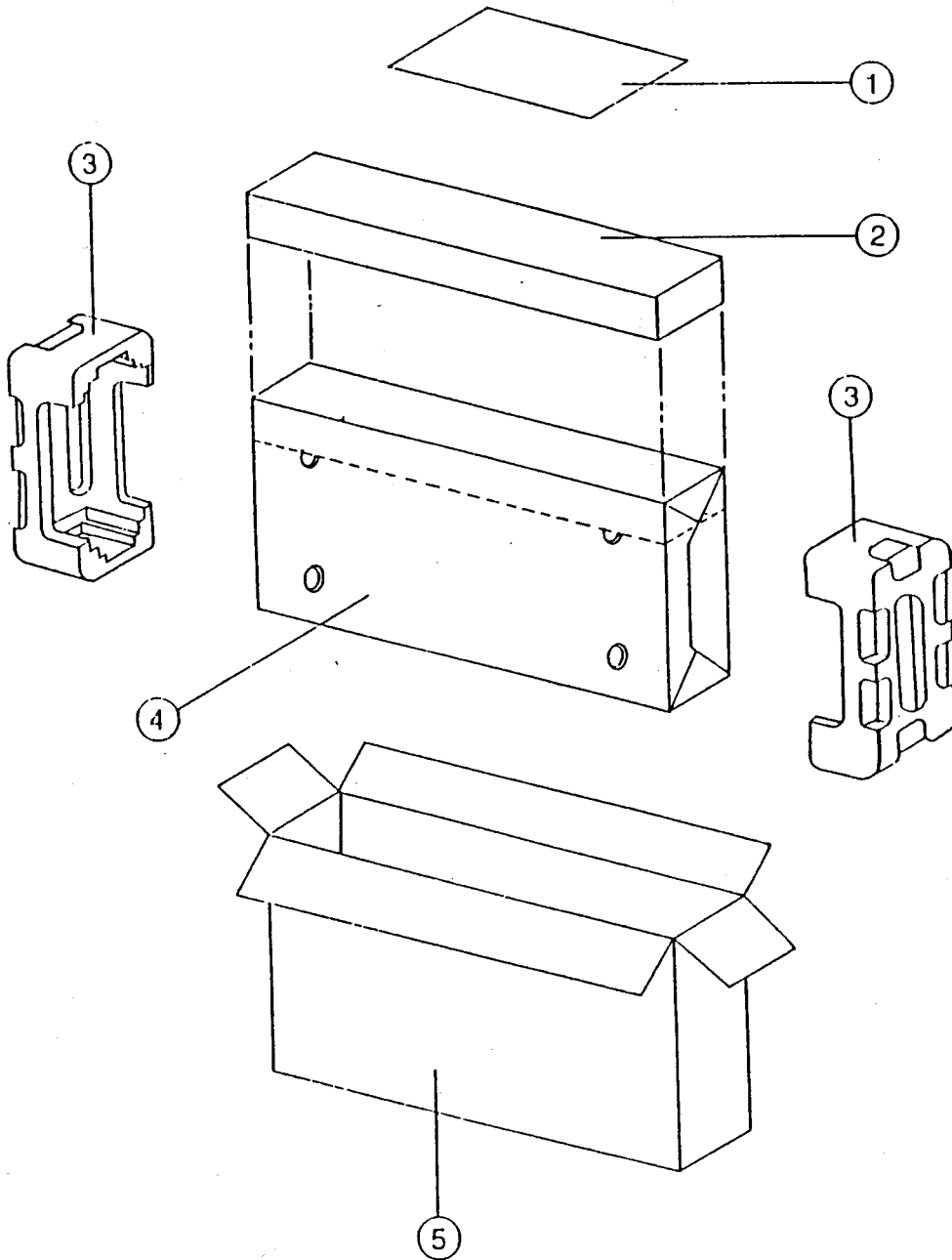

PACKING DIAGRAM FOR HAD-7220PE / 7020e

ITEM	NUMBER	NAME	Q'TY
1	5535121911	OWNS MANUAL	1
2	9530520255	EPE BAG	1
3	9520520155	POLYLON	2
4	9530520155	PE BAG	1
5	9510520455	GIFT BOX	1