

SERVICE MANUAL

NAD MODEL 7045/7060

AM/FM STEREO RECEIVER

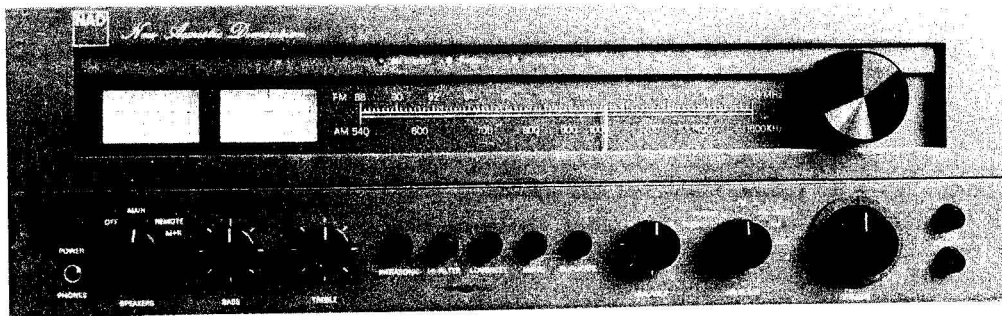

CONTENTS

SPECIFICATION	PAGE	2, 3
INSIDE VIEW OF UNIT	PAGE	4
ALIGNMENT (AUDIO)	PAGE	5
ALIGNMENT (TUNER)	PAGE	6, 7
PCB PARTS LOCATION	PAGE	8, 9
WIRING DIAGRAM	PAGE	10
CIRCUIT DIAGRAM (7045)	PAGE	11
CIRCUIT DIAGRAM (7060)	PAGE	12
PARTS LIST	PAGE	13, 14, 15, 16, 17

SPECIFICATION

* Measurements identified by an asterisk are taken in accordance with the new IHF A-202 amplifier measurement standard.

	7045	7060
Power Amplifier Section		
* Continuous average power output at 8 ohms 20–20K Hz both channel driven	45W	60W
Rated distortion, 20–20K Hz	0.05%	0.030%
* Clipping headroom at 8 ohms	+1.2dB	+1.2dB
Clipping power at 8 ohms	60W	80W
at 4 ohms	80W	120W
at 2 ohms	90W	130W
Dynamic headroom at 8 ohms	+2.2dB	+2.2dB
Dynamic power at 8 ohms	75W	100W
at 4 ohms	100W	160W
at 2 ohms	120W	180W
* Reactive load rating	+1.7dB	+1.7dB
* Transient Overload Recovery Time	< 1μsec	< 1μsec
* Slew Factor	250	750
Slew Rate	20V/μsec	30V/μsec
Damping factor at 50 Hz (Ref. 8 ohms)	75	100
T.H.D. 20–20K Hz From 250 mW to 45W/60W	< 0.05%	< 0.03%
S.M.P.T.E. I.M.D. (60 Hz + 7KHz, 4:1) From 250mW to 45W/60W	< 0.05%	< 0.04%
I.H.F. I.M.D. (19KHz + 20KHz) at 45W/60W	< 0.05%	< 0.03%
T.I.M. (15KHz Sine + 3.18KHz Square Wave) at 45W/60W	< 0.05%	< 0.03%
Frequency Response, 20–20K HZ	±0.5dB	±0.5dB
Frequency Response Range ± 3dB	5–50K	5–50K
Pre-amplifier Section		
* Input Impedance Resistance/Capacitance	47K/47PF	47K/47PF
Input Sensitivity (1KHz) * For 1 watt out	0.4mV	0.3mV
45/60 Watt out	2.5mV	2.5mV
Input Overload at 1KHz	200mV	200mV
20 Hz	20mV	20mV
20 KHz	2.0V	2.0V
THD (20–20K Hz) and IMD at + 30dB input level	< 0.01%	< 0.01%
RIAA Response Accuracy	±0.3dB	±0.3dB
Signal to Noise Ratio A-weighted		
(a) with phono cartridge connected	* Ref 10mV > 82dB	> 82dB
(b) with short-circuit input	* Ref 5mV Ref 10mV > 76dB > 90dB	> 76dB > 90dB
High level input		
* Input impedance Resistance/Capacitance	25KΩ/100PF	25KΩ/100PF
Input sensitivity * For 1 watt out	25mV	20mV
For 30 watt out	150mV	150mV
Signal to Noise Ratio, A-Weighted		
* Ref 1 watt out	> 80dB	> 80dB
Ret 45W/60W out	> 92dB	> 95dB
* Maximum input signal		
Frequency Response, 20–20K Hz	±0.5dB	± 0.5dB
Controls		
Bass control, range at 50 Hz	±10dB	± 10dB
Treble control, range at 10 KHz	±10dB	± 10dB
Infrasonic filter Turn over frequency	20Hz	20Hz
Slope (dB/octave)	12	12
High filter Turn over frequency	7KHz	7KHz
Slope (dB/octave)	6	6

SPECIFICATION

FM Tuner Section

Input Sensitivity	IHF, 30dB quieting		1.9 μ V
	IHF, 50dB S/N Mono		3.5 μ V
	IHF, 50dB S/N Stereo		45 μ V
Signal to Noise Ratio (A Weighted, at 65 dBf) mono			72dB
			68dB
Frequency Response, 30–15K Hz			+0.5dB
De-emphasis Accuracy 75 μ sec			+0.3dB
Channel Separation	1 KHz		40dB
	30 – 15K HA		30dB
Selectivity, alternate channel (400 KHZ)			62dB
Capture Ratio at 45 dBf and 65 dBf			1.5dB
AM Suppression at 45dBf and 65dBf			60dB
Image Rejection			50dB
I. F. Rejection			60dB
SCA Rejection			70dB
Pilot Signal Suppression			55dB
THD at 100% Modulation	1 KHZ	Mono	0.2%
		Stereo	0.3%
	100 HZ	Mono	0.2%
		Stereo	0.3%
	6 KHZ	Mono	0.3%
		Stereo	0.4%
THD, Stereo, 1 KHZ	50%	Modulation	0.3%
	150%	Modulation	0.4%

AM Tuner Section

Usable Sensitivity		300 μ V
Selectivity		30dB
Image Rejection		50dB
I. F. Rejection		40dB

Physical Specification

Dimensions	Width x Height x Depth	45 x 36 x 14cm
Net Weight	7045/7060	13.5 / 15.5 kg
Shipping Weight	7045/7060	16 / 18 kg
Power Consumption	at 1 Watt out	30 VA
	at 45 / 60 Watt out	250VA/300VA

INSIDE VIEW OF UNIT

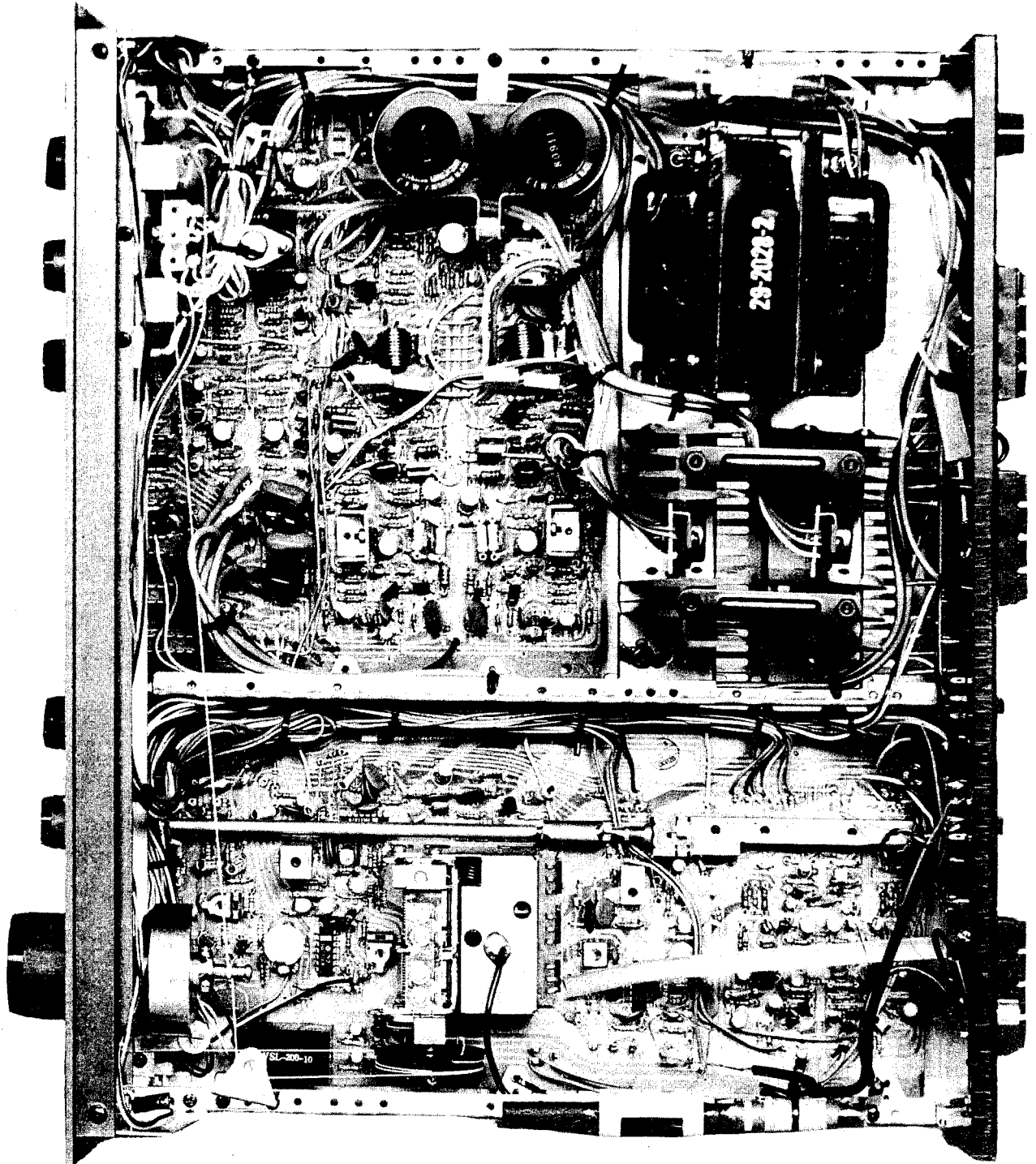

ALIGNMENT (AUDIO)

1. IDLE CURRENT ALIGNMENT

1. 5 Minutes minimum pre-heating is necessary for idle current alignment.
2. Set the volume control at minimum position.
3. Speaker switch should be set at off position.
4. Connect DC voltmeter across R663 for right channel and across R664 for left channel. (see fig. 1)
5. Record the reading of DC voltmeter and refer to the following chart to find the appropriate value resistor to connect in parallel with R637 (right channel), or R638 (left channel) on the bottom side (pattern side) of PCB.
- * Important notice: The power switch must be in the off position when soldering is done.

Reading of DC Voltmeter	Parallel Resistor	Reading of DC Voltmeter	Paralle Resistor
0.4 to 1.1mV	3K3	2.8 to 3.5mV	5K6
1.2 to 1.9mV	3K9	3.6 to 4.3mV	6K8
2.0 to 2.7mV	4K7	4.4 to 5.0mV	8K2

6. Read the DC voltage across to R663 (right channel) and R664 (left channel) again.
7. If the DC voltage were between 5 mV and 10mV, then the alignment is completed.
8. If the DC voltage were less than 5 mV, the value of parallel resistor should be increased until the DC voltage is between 5mV and 10mV.
9. If the DC voltage were more than 10 mV, the value of parallel resistor should be reduced until the DC voltage is between 5mV and 10mV.

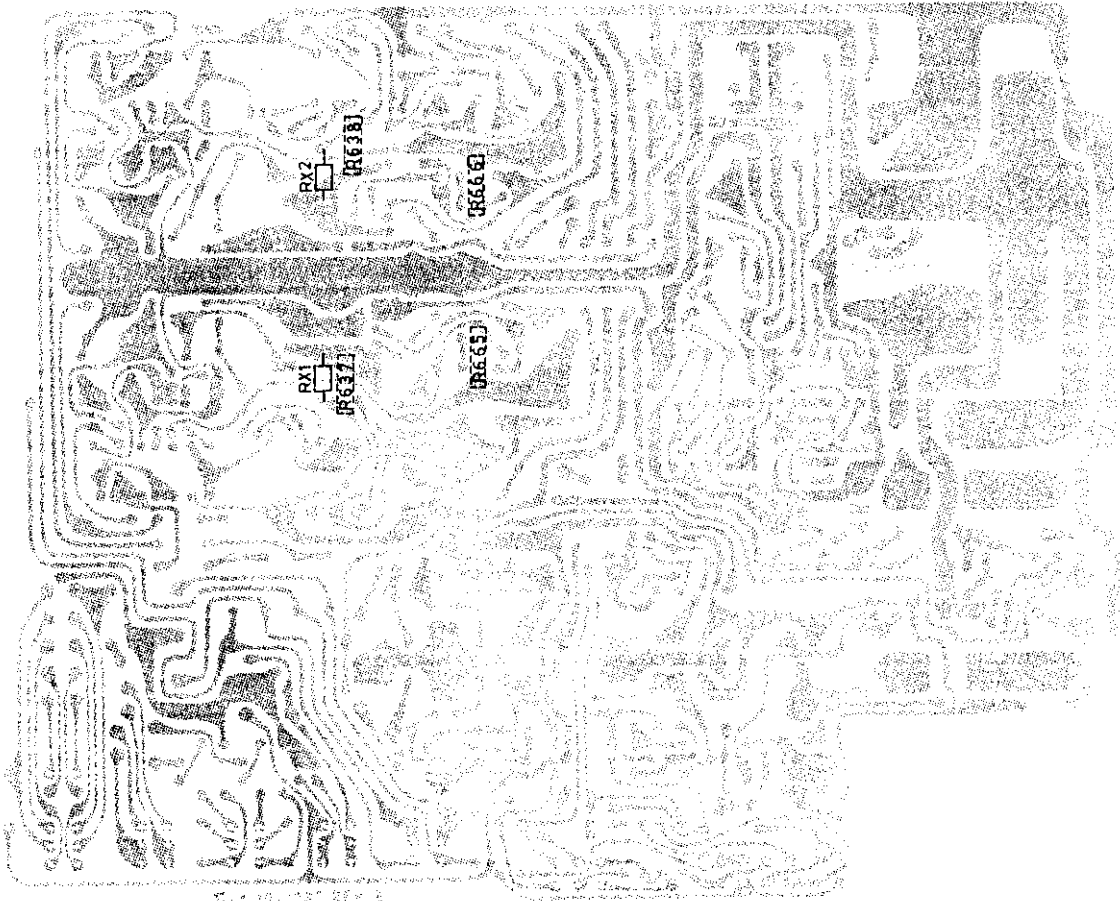

ALIGNMENT (TUNER)

1. AM ALIGNMENT: 1. Selector switch in AM position 2. AC line voltage at rated voltage 3. Monitor output at REC OUT (TAPE 1 or TAPE 2)										
Section	AM SG			Dial Setting	Indicator	Adjustment Point	Adjust for			
	Connection	Carrier Freq.	Modulation							
AM IF	Hot side of SG output through 200 pF to AM antenna trimmer Terminal (TP 1)	455 KHz	30% Mod. 400 Hz	Point of non-interference	V. T. V. M. or Oscilloscope	LT301	Maximum output			
AM RF	Hot side of SG output through 200 pF to EXT AM antenna Terminal on rear panel	600KHz	30% MOD. 400 Hz	600KHz	V. T. V. M. or Oscilloscope	LA 101	Maximum output			
		1400 KHz	30% MOD 400Hz	1400KHz		TC - 2				
		Repeat Step 4 and Step 2								
2. FM ALIGNMENT: 1. Selector switch in FM position and Mode switch in stereo position 2. AC line voltage at rated voltage 3. Monitor output at REC OUT (TAPE 1 or TAPE 2)										
Section	FM SG			Dial Setting	Indicator	Adjustment Point	Adjust for			
	Connection	Carrier Freq.	Modulation							
FM IF	—	—	—	Point of non-interference	Tuning Meter off set	LT 101 (Discri. IFT) primay A	Center Indication			
FM RF	Connect to FM 300 ohm antenna Terminal on the rear panel through FM dummy antenna	90MHz	100% Mod 400 Hz	90 MHz	V. T. V. M. or Oscilloscope	L - 1	Maximum output			
		106MHz		106 MHz		TC-1, TC-3				
		Repeat Step 1 and Step 2								
FM Mono Distortion		98MHz	100% Mod. 400Hz	98MHz	Distortion Meter	LT upper side	Minimum Distortion			
		Repeat FM IF and FM MONO DISTORTION step 1.								
3. FM MPX ALIGNMENT: 1. Same as FM ALIGNMENT 1, 2, 3 2. FM SG is external modulated by stereo SG and connected to FM 300Ω antenna terminal on the rear panel through FM dummy antenna										
Section	Step	FM SG	Stereo SG	Dial Setting	Indicator	Adjustment	Adjust for			
MPX pilot	1	—	—	Point of no signal received	Connet frequency counter through look to TP 10	VR 201	19KHZ ± 30HZ			
	2	98MHz	10% 19KHz Pilot 90% L + R, L - R	98MHz	—	VR201	Stereo LED Light			
Separation	1	98MHz	10% 19KHz Pilot L. only	98MHz	Connect VTI VTIM or oscilloscope to R REC out	VR202	Minimum output			
	2		10% 19KHz Pilot R. only	98MHz	Connect VTVM or oscilloscope to L REC out	VR202				
	3		Repeat Step 1 and Step 2							
	4		If there is an excessive difference between leak-free effects of both channels, slightly adjust VR 202 so that the levels of signal leakage of both channels are equal							

ALIGNMENT (TUNER)

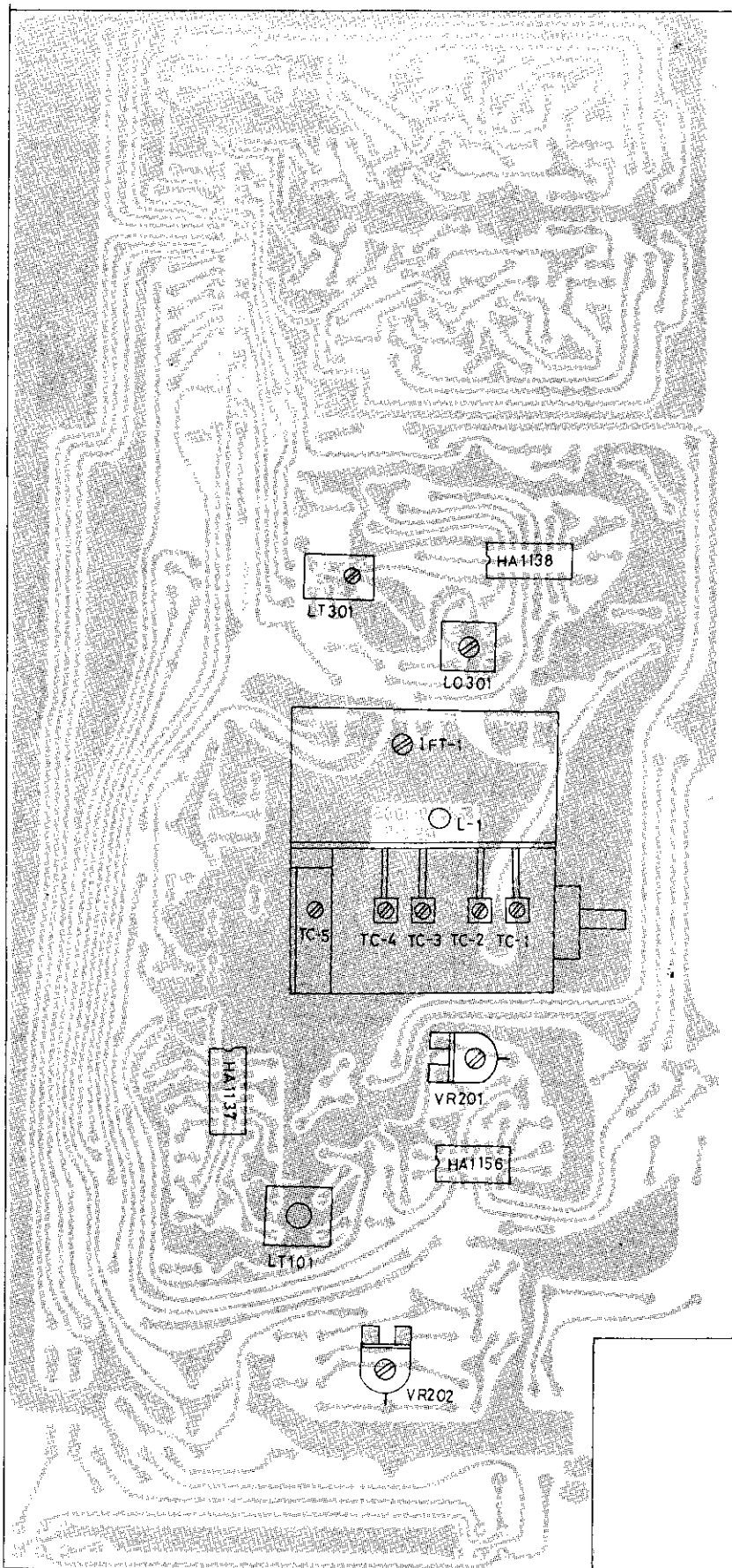

PCB PARTS LOCATION

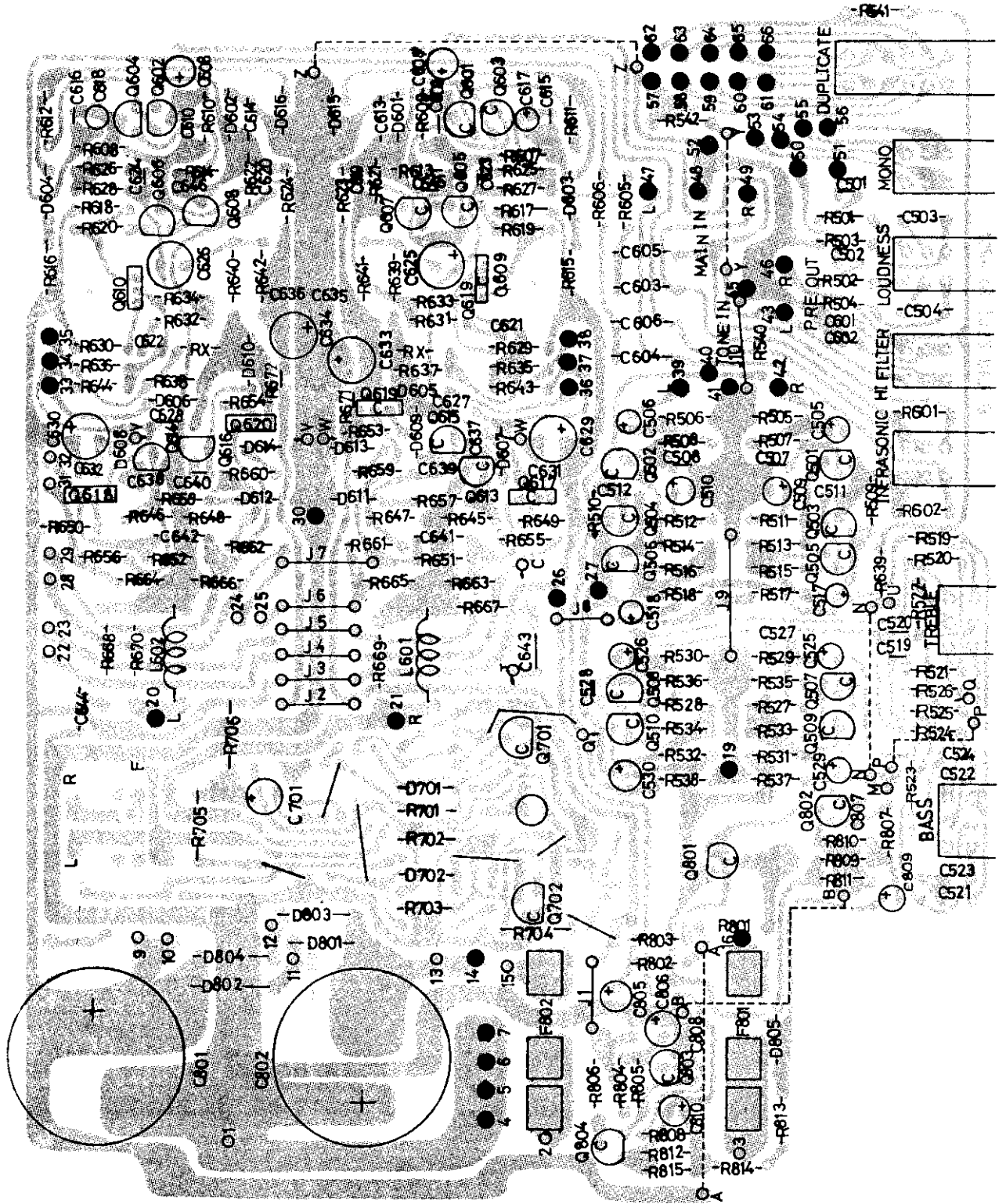

PCB PARTS LOCATION

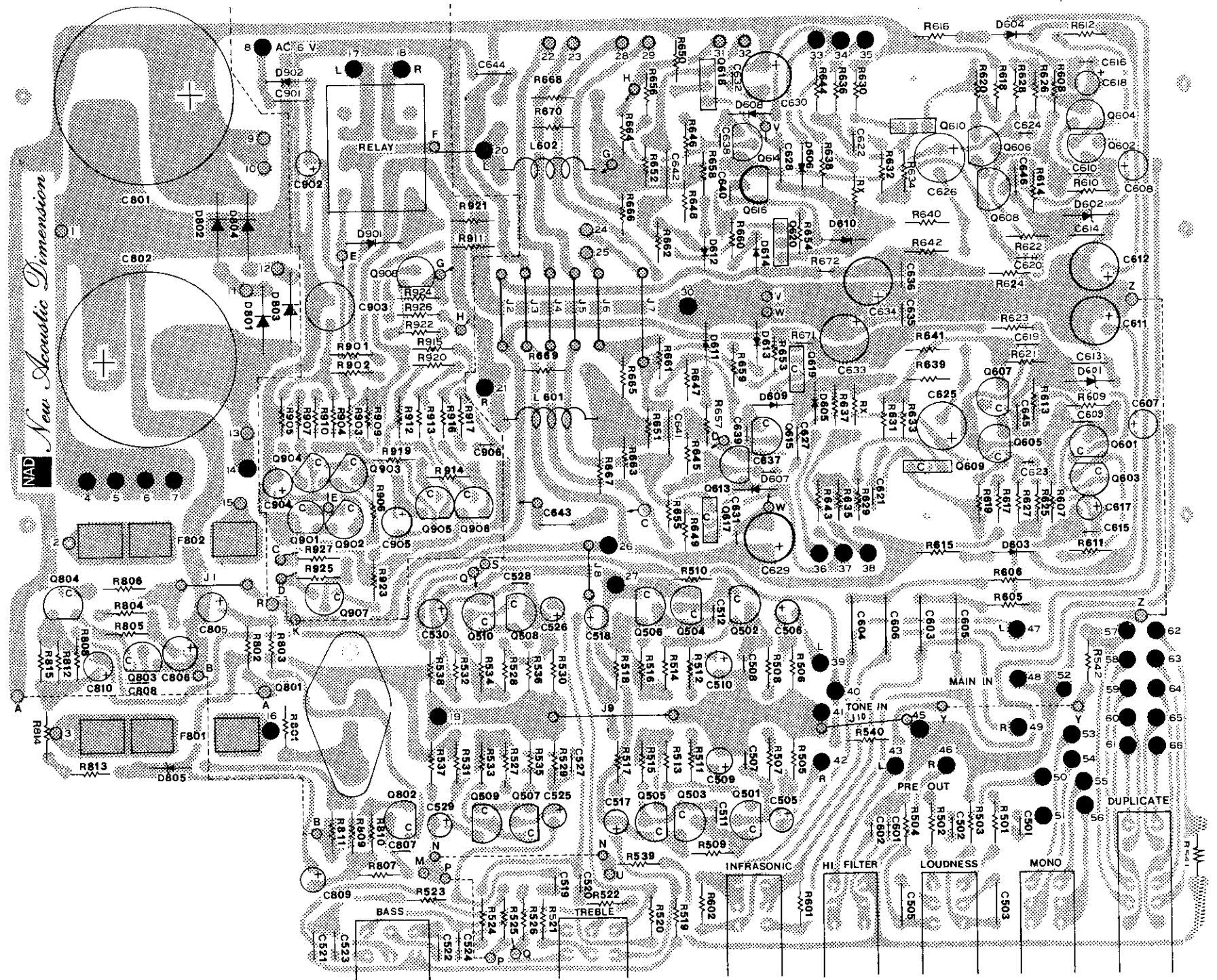
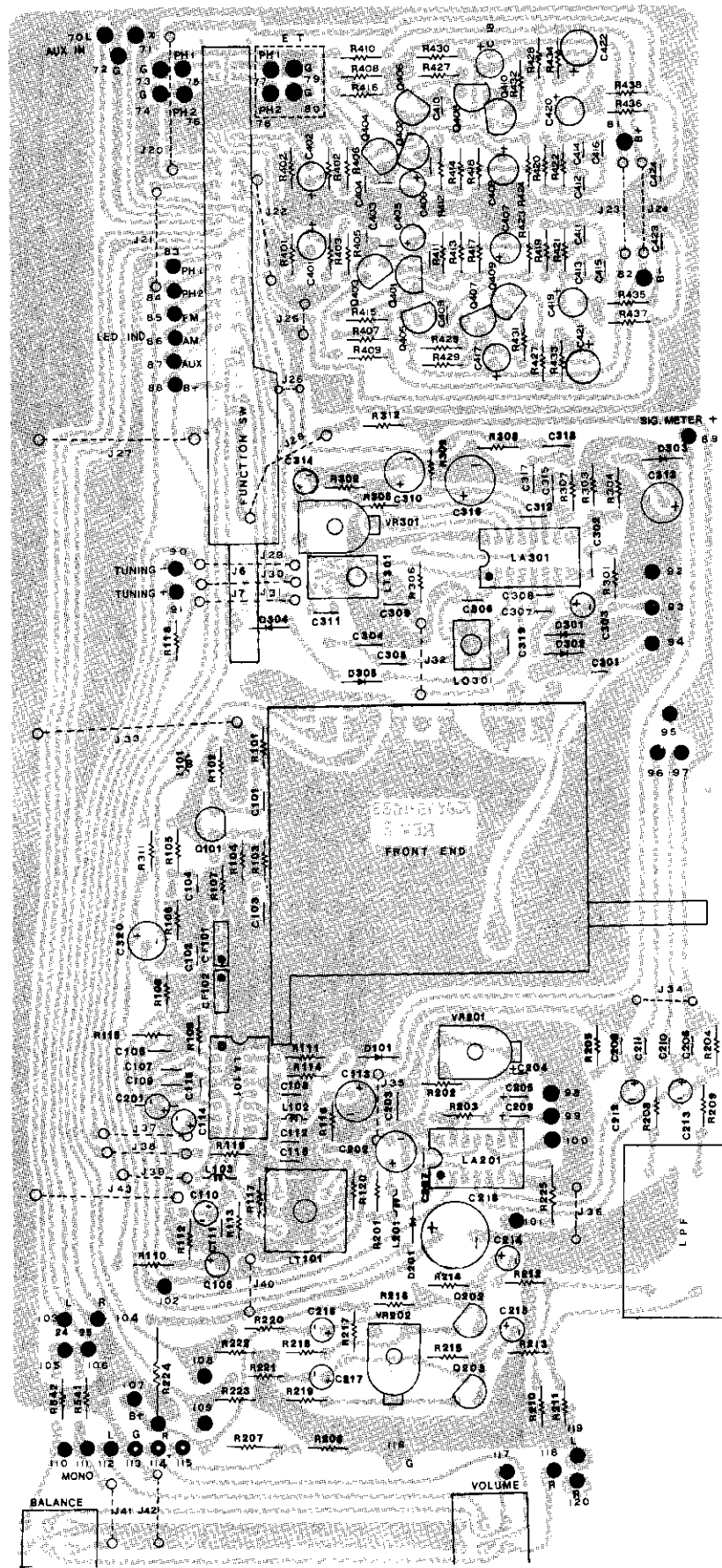

7045/7060

7060

WIRING DIAGRAM

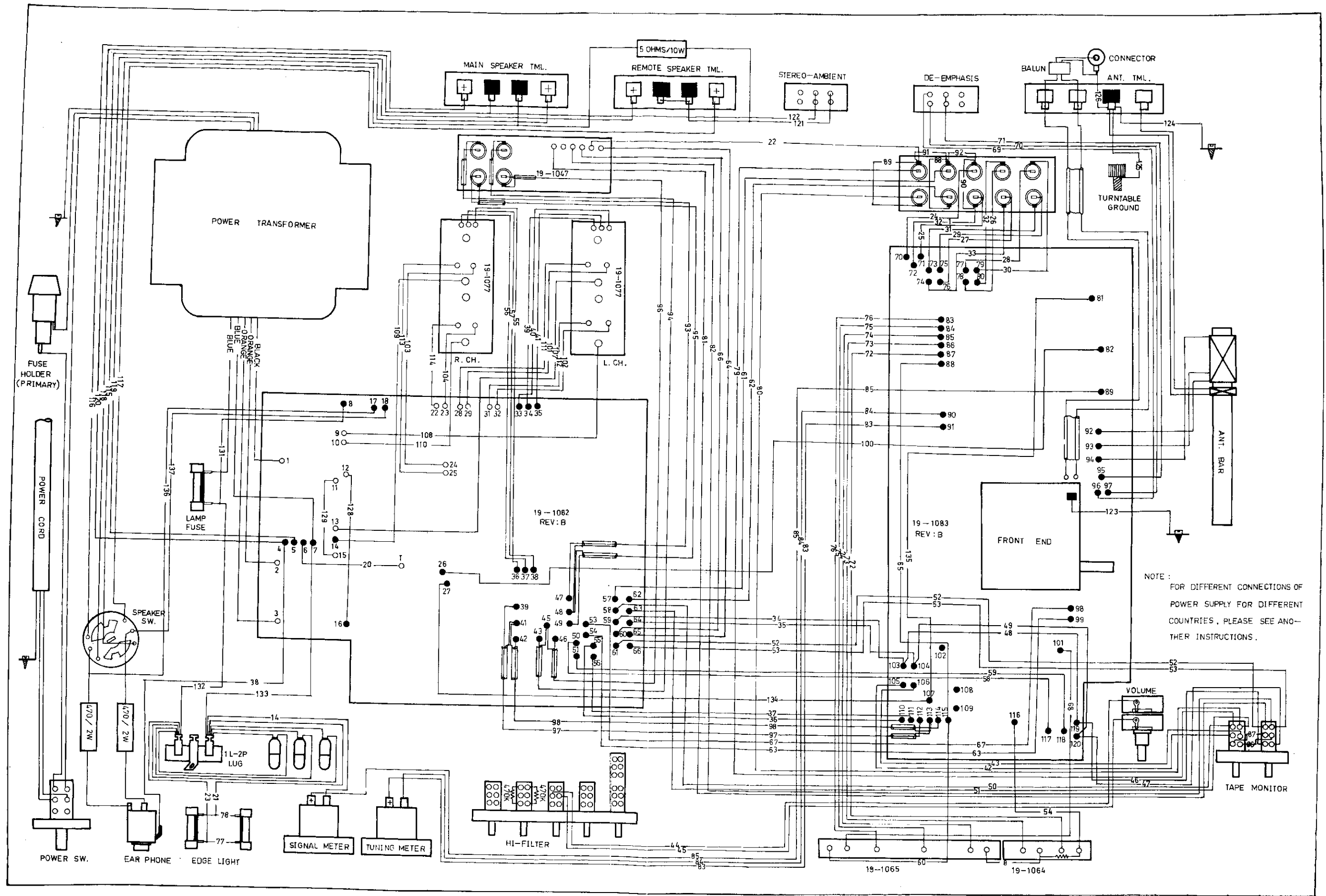

CIRCUIT DIAGRAM (7045)

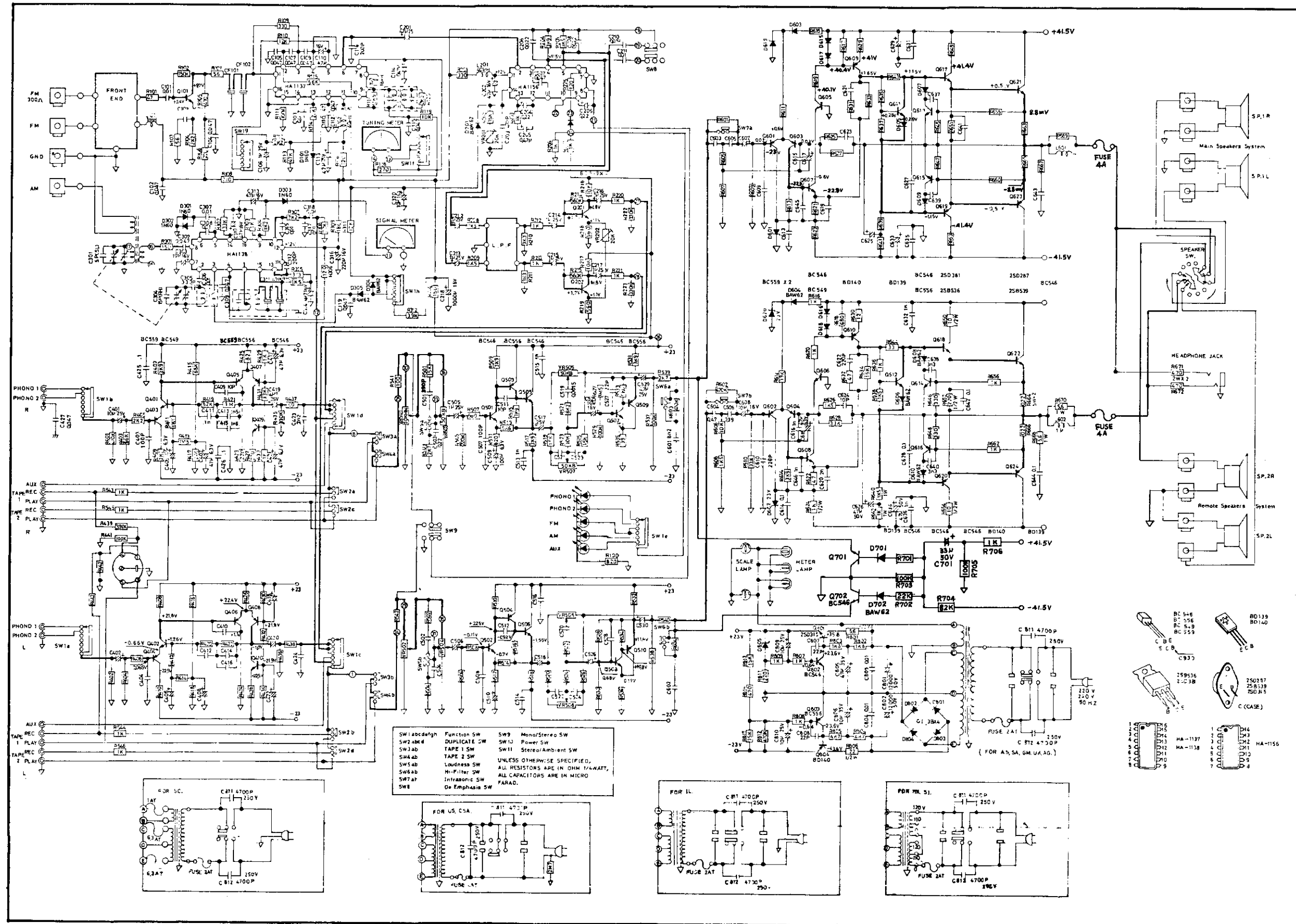

SW1 abcdefgh Function SW SW9 Mono/Stereo SW
 SW2 abcde Duplicate SW SW10 Power SW
 SW3 ab Tape 1 SW SW11 Stereo/Ambient SW
 SW4 ab Tape 2 SW UNLESS OTHERWISE SPECIFIED.
 SW5 ab Loudness SW ALL RESISTORS ARE IN OHM 1/4-WATT.
 SW6 ab Hi-Filter SW ALL CAPACITORS ARE IN MICRO
 SW7 a Intrasonic SW FARAD.
 SW8 Emphasis SW

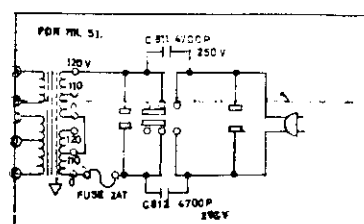
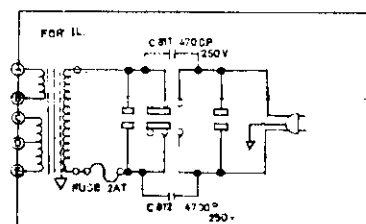
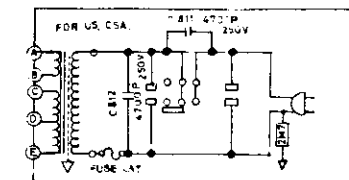
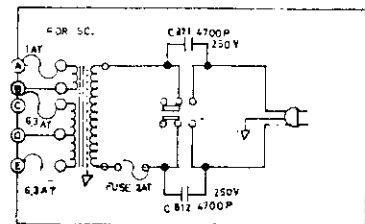

- BC 546
- BC 559
- BC 556
- BD 139
- BD 140
- C 930
- C 933
- 259536
- 259538
- 250287
- 258339
- 250385
- C (CASE)
- HA-1137
- HA-1138
- HA-1155

CIRCUIT DIAGRAM (7060)

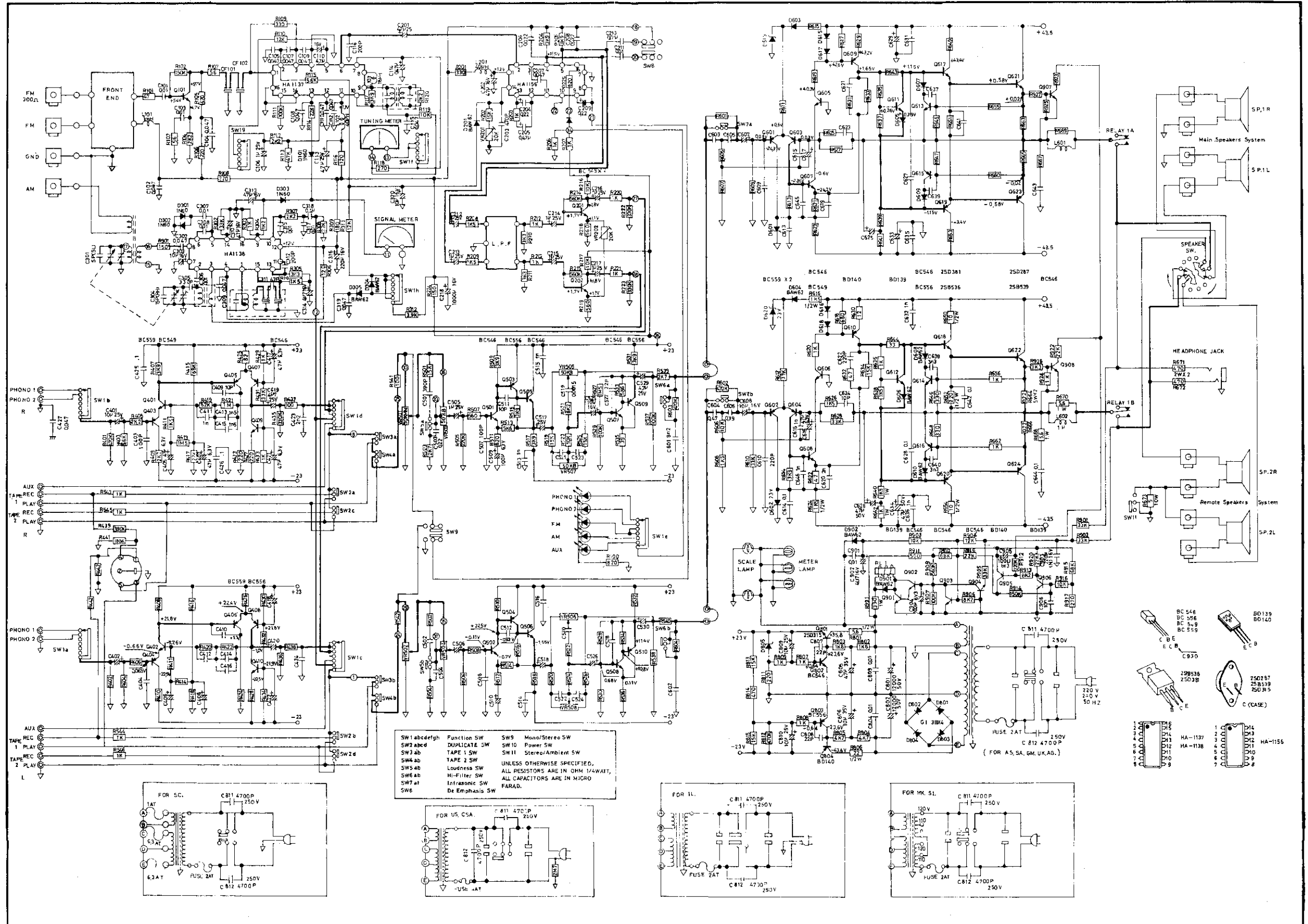

PARTS LIST

90-1083 (7045, 7060)				
ITEM	PARTS NO	DESCRIPTION	QTY	SYMBOL NO
1	16-1/4CN102J	CARBON RES 1K OHM 1/4W +- 5%	1	R207
2	16-1/4CM101J	CARBON RES 100 OHM 1/4W +- 5%	4	R405,406,437,438
3	16-1/4CM102J	CARBON RES 1K OHM 1/4W +- 5%	10	R203,212,213,220,221,303,329, 330,333,334
4	16-1/4CM103J	CARBON RES 10K OHM 1/4W +- 5%	3	R119,216,217
5	16-1/4CM104J	CARBON RES 100K OHM 1/4W +- 5%	1	R111
6	16-1/4CM105J	CARBON RES 1M OHM 1/4W +- 5%	2	R421,422
7	16-1/4CM121J	CARBON RES 120 OHM 1/4W +- 5%	1	R306
8	16-1/4CM122J	CARBON RES 1.2 K OHM 1/4W +- 5%	1	R304
9	16-1/4CM123J	CARBON RES 12K OHM 1/4W +- 5%	1	R110
10	16-1/4CM151J	CARBON RES 150 OHM 1/4W +- 5%	1	R301
11	16-1/4CM152J	CARBON RES 1.5K OHM 1/4W +- 5%	5	R208,209,310,411,412
12	16-1/4CM153J	CARBON RES 15K OHM 1/4W +- 5%	1	R202
13	16-1/4CM154J	CARBON RES 150K OHM 1/4W +- 5%	1	R102
14	16-1/4CM155J	CARBON RES 1.5M OHM 1/4W +- 5%	2	R413,414
15	16-1/4CM222J	CARBON RES 2.2K OHM 1/4W +- 5%	6	R104,112,120,307,409,410
16	16-1/4CM223J	CARBON RES 22K OHM 1/4W +- 5%	4	R114,308,417,418
17	16-1/4CM271J	CARBON RES 270 OHM 1/4W +- 5%	1	R118
18	16-1/4CM331J	CARBON RES 330 OHM 1/4W +- 5%	1	R109
19	16-1/4CM332J	CARBON RES 3.3K OHM 1/4W +- 5%	3	R210,211,205
20	16-1/4CM333J	CARBON RES 33K OHM 1/4W +- 5%	3	R302,431,432
21	16-1/4CM334J	CARBON RES 330K OHM 1/4W +- 5%	2	R222,223
22	16-1/4CM392J	CARBON RES 3.9K OHM 1/4W +- 5%	5	R117,204,205,407,408
23	16-1/4CM470J	CARBON RES 47 OHM 1/4W +- 5%	1	R101
24	16-1/4CM471J	CARBON RES 470 OHM 1/4W +- 5%	1	R105
25	16-1/4CM473J	CARBON RES 47K OHM 1/4W +- 5%	1	R113
26	16-1/4CM474J	CARBON RES 470K OHM 1/4W +- 5%	2	R401,402
27	16-1/4CM560J	CARBON RES 56 OHM 1/4W +- 5%	2	R103,107
28	16-1/4CM561J	CARBON RES 560 OHM 1/4W +- 5%	2	R218,219
29	16-1/4CM563J	CARBON RES 56K OHM 1/4W +- 5%	3	R115,403,404
30	16-1/4CM564J	CARBON RES 560K OHM 1/4W +- 5%	2	R214,215
31	16-1/4CM683J	CARBON RES 68K OHM 1/4W +- 5%	2	R415,416
32	16-1/4CM821J	CARBON RES 820 OHM 1/4W +- 5%	1	R225
33	16-1/4CM823J	CARBON RES 82K OHM 1/4W +- 5%	2	R419,420
34	16-1/4CN102J	CARBON RES 1K OHM 1/4W +- 5%	1	R206
35	16-1/4CN121J	CARBON RES 120 OHM 1/4W +- 5%	1	R116
36	16-1/4CN123J	CARBON RES 12K OHM 1/4W +- 5%	1	R311
37	16-1/4CN181J	CARBON RES 180 OHM 1/4W +- 5%	1	R309
38	16-1/4CN221J	CARBON RES 220 OHM 1/4W +- 5%	7	R106,108,201,423,424,427,428
39	16-1/4CN392J	CARBON RES 3.9K OHM 1/4W +- 5%	1	R312
40	16-1/4CN820J	CARBON RES 82 OHM 1/4W +- 5%	2	R425,426
41	16-1A121J	METAL OXIDE 120 OHM 1/4W +- 5%	1	R224
42	17-0.63E476Y	ELEC CAPA. 47μF/6.3V +50-10%	8	C405-408, 421,422,417,418
43	17-1.6E108Y	ELEC CAPA 1000μF/16V +50-10%	1	C218
44	17-1.6E227Y	ELEC CAPA 220μF/16V +50-10%	1	C316
45	17-1.6E475Y	ELEC CAPA 47μF/16V +50-10%	4	C113,202,310,313
46	17-1.6O224M	TA, CAPA, 0.22μF/16V +-20%	2	C204,209
47	17-1.6O474M	TA, CAPA, 0.47μF/16V +-20%	1	C205
48	17-2.5E105Y	ELEC CAPA 1μF/25V +50-10%	7	C106,212-217
49	17-2.5E106Y	ELEC CAPA 10μF/25V +50-10%	4	C303,320,401,402
50	17-2.5E474Y	ELEC CAPA 0.47μF/25V +50-10%	1	C114
51	17-2.5E475Y	ELEC CAPA 4.7μF/25V +75-10%	5	C110,201,314,419,420
52	17-5D100D	CER CAPA 10PF +- 0.5P 50V	2	C409,410
53	17-5D103M	CER CAPA 0.01μF +- 20% 50V	7	C101,103,306,307,308,315,317, 318
54	17-5D104M	CER CAPA 0.1μF +- 20% 50V	1	C318
55	17-5D201K	CER CAPA 200PF +-10% 50V	1	C116
56	17-5D473M	CER CAPA 0.047μF +- 20% 50V	12	C102,104,105,107,108,109,111, 112,115,302,309,319
57	17-5D500M	CER CAPA 50PF +- 20% 50V	2	C403,404
58	17-5D5ROD	CER CAPA 5PF +- 0.5% 50V	1	C301
59	17-5F102J	MYLAR CAPA 0.001μF +- 5% 50V	2	C411,412
60	17-5F103J	MYLAR CAPA 0.01μF +- 5% 50V	2	C210,211
61	17-5F152J	MYLAR CAPA 0.0015μF +- 5% 50V	4	C413-416
62	17-5F222J	MYLAR CAPA 0.0022μF 50V +- 5%	2	C423,424
63	17-5F223J	MYLAR CAPA 0.022μF 50V +- 5%	2	C206,208
64	17-5F473J	MYLAR CAPA 0.047μF 50V +- 5%	1	C207
65	17-5M331J	SILVERED MICA 330PF 50V +- 5%	1	C305
66	17-5U471J	STYROLONE CAPA 470PF 50V +- 5%	1	C203
67	17-5V150K	CER CAPA 15PF 50V (RH) +- 10%	1	C304

ITEM	PARTS NO	DESCRIPTION	Q'TY	SYMBOL NO
13	16-¼CM272J	CARBON RES 2.7K OHM ¼W +-5%	2	R503, 504
14	16-¼CM330J	CARBON RES 33 OHM ¼W +-5%	2	R643, 644
15	16-¼CM333J	CARBON RES 33K OHM ¼W +-5%	4	R609, 610, 627, 628
16	16-¼CM390J	CARBON RES 39 OHM ¼W +-5%	2	R535, 536
17	16-¼CM391J	CARBON RES 390 OHM ¼W +-5%	0	
18	16-¼CM392J	CARBON RES 3.9K OHM ¼W +-5%	10	R509, 510, 515-518, 531, 532, 613, 614
19	16-¼CM393J	CARBON RES 39K OHM ¼W +-5%	2	R611, 612
20	16-¼CM470J	CARBON RES 47 OHM ¼W +-5%	4	R621, 622, 631, 632
21	16-¼CM471J	CARBON RES 470 OHM ¼W +-5%	1	R814
22	16-¼CM472J	CARBON RES 4.7 KOHM ¼W +-5%	6	R513, 514, 539, 540, 804, 805
23	16-¼CM474J	CARBON RES 470 KOHM ¼W +-5%	5	R601-604, 812
24	16-¼CM561J	CARBON RES 560 K OHM ¼W +-5%	2	R507, 508
25	16-¼CM562J	CARBON RES 5.6K OHM ¼W +-5%	2	R533, 534
26	16-¼CM681J	CARBON RES 680 OHM ¼W +-5%	0	
27	16-¼CM821J	CARBON RES 820 OHM ¼W +-5%	2	R511, 512
28	16-¼CM822J	CARBON RES 8.2K OHM ¼W +-5%	2	R521, 522
29	16-¼CM823j	CARBON RES 82K OHM ¼W +-5%	1	R704
30	16-¼CM102J	CARBON RES 1K OHM ¼W +-5%	2	R615, 616
31	16-¼CN182J	CARBON RES 1.8K OHM ¼W +-5%	2	R802, 803
32	16-¼CN330J	CARBON RES 33 OHM ¼W +-5%	2	R629, 630
33	16-¼CN681J	CARBON RES 680 OHM ¼W +-5%	2	R617, 618
34	16-¼CU101J	CARBON RES 100 OHM ¼W +-5%	0	
35	16-½CP100J	CARBON RES 10 OHM ½W +-5%	4	R649, 650, 653, 654
36	16-½CP102J	CARBON RES 1K OHM ½W +-5%	2	R623, 624
37	16-½CP220J	CARBON RES 22 OHM ½W +-5%	1	R806
38	16-½CP221J	CARBON RES 220 OHM ½W +-5%	2	R651, 652
39	16-½CP5R6J	CARBON RES 5.6 OHM ½W +-5%	1	R801
40	16-1A102J	METAL OXIDE RES 1K OHM1W +-5%	2	R641, 642
41	16-1A152J	METAL OXIDE RES 1.5K OHM 1W +-5%	2	R639, 640
42	16-1A5R6J	METAL OXIDE RES 5.6 OHM 1W +-5%	4	R667-670
43	16-1003	RES MPC71 0.22 OHM 5W	4	R663-666
44	17-0.63E107Y	ELEC CAPA 100µf/6.3V +50-10%	2	C509, 510
45	17-0.63E476Y	ELEC CAPA 47µf/6.3V +50-10%	2	C617, 618
46	17-1.6E106Y	ELEC CAPA 10µf/16V +50-10%	8	C517, 518, 525, 526, 529, 530, 607, 608
47	17-2.5E106Y	ELEC CAPA 10µf/25V +50-10%	2	C809, 810
48	17-3.5E106Y	ELEC CAPA 10µf/35V +50-10%	1	C806
49	17-3.5E476Y	ELEC CAPA 47µf/35V +50-10%	1	C805
50	17-5E105Y	ELEC CAPA 1µf/50V +75-10%	2	C505, 506
51	17-5E336Y	ELEC CAPA 33µf/50V +50-10%	1	C701
52	17-5E476Y	ELEC CAPA 47µf/50V +50-10%	5	C625, 626, 629, 633, 634
53	17-5D100D	CER CAPA 10P +-0.5P 50V	4	C511, 512, 623, 624
54	17-5D101M	CER CAPA 100P +-20% 50V	2	C507, 508
55	17-5D102M	CERCAPA 1000P +-20% 50V	6	C615, 616, 631, 632, 635, 636
56	17-5D104M	CER CAPA 0.1µf+-20% 50V	2	C613, 614
57	17-5D220M	CER CAPA 22P +-20% 50%	4	C527, 528, 807, 808
58	17-5D221M	CER CAPA 220P +-20% 50V	4	C609, 610, 621, 622
59	17-5D332M	CER CAPA 0.0033µf +-20% 50V	4	C637-640
60	17-5D821M	CER CAPA 820P +-20% 50%	2	C501, 502
61	17-25D104M	CER CAPA 0.1µf +-20% 250V	0	
62	17-5F102J	MYLAR CAPA 0.001µf+-5% 50V	4	C519, 520, 645, 646
63	17-5F104J	MYLAR CAPA 0.1µf+-5% 50V	6	C641-644, 627, 628
64	17-5F222J	MYLAR CAPA 0.0022µf +-5% 50V	2	C619, 620
65	17-5F224J	MYLAR CAPA 0.22µf +-5% 50V	2	C503, 504
66	17-5F394J	MYLAR CAPA 0.39µf +-5% 50V	2	C605, 606
67	17-5F472J	MYLAR CAPA 0.0047µf +-5% 50V	2	C601, 602
68	17-5F473J	MYLAR CAP 0.047µf +-5% 50V	4	C521-524
69	17-5F474J	MYLAR CAPA 0.47µf +-5% 50V	2	C603, 604
70	19-1082	P.C.B. (MWN AMP)	1	
71	29-1036-1	AIR COIL 3.3µH	2	L601, 602
72	29-4028	VOLUME CONTROL GM70E-50KB-2	2	VR503, 504
73	29-4071	VOLUME CONTROL GM70E-50KMN-2	1	VR501
74	29-4072	VLLUME CONTROL GM80E-50KB-2	1	VR502
75	30-1016	ZENER DIODE 23V 0.5W	5	D601, 602, 619, 620, 805,
76	30-1017-1	DIODE G3B	4	D801-804
77	30-1019	DIODE BAW62	14	D603-614, 901, 902
78	30-2080	TRANSISTOR 2SD315E	1	Q801
79	30-2082	TRANSISTOR BD140	3	Q609, 610, 804
80	30-2084-3	TRANSISTOR BC549C	2	Q901, 906
81	30-2085-2	TRANSISTOR BC559B	4	Q601-604
82	30-2086	TRANSISTOR 2SB536M	2	Q619, 620
83	30-2087	TRANSISTOR 2SD381M	2	Q617, 618
84	30-2090-2	TRANSISTOR 2SD381M	2	Q501, 502, 505-508, 605,

ITEM	PARTS NO	DESCRIPTION	Q'TY	SYMBOL NO
68	17-5V470K	CER CAPA 47PF 50V(RH) +-10%	1	C311
69	17-5W221K	CER CAPA 220PF 50V(SL) +- 10%	1	C312
70	18-1004-8	CORE ASS'Y	2	L401,402
71	29-1037	INDUCTOR 1mH	1	L101
72	29-1038	INDUCTOR 40mH	2	L102,201
73	29-1039	INDUCTOR 18mH	1	L103
74	29-3008	FM DET COIL 10.7MHz	1	LT101
75	29-3016-1	L.P.F. 19,38KHz FILTER	1	
76	29-3017	CERAMIC SFL 455A	1	LT301
77	29-3018	AM OSC L-39	1	LO301
78	29-3027	CERAMIC FILTER SFE 10.7MA8	2	CF101,102
79	29-4023-1	SEMIFIXED RES 20K	2	VR201,202
80	30-1010	DIODE IN60	4	D101,301-303
81	30-1019	DIODE BAW62	3	D201,304,305
82	30-2019	TRANSISTOR 2SC930C	1	Q101
83	30-2084-2	TRANSISTOR BC549B	2	Q401,402
84	30-2084-3	TRANSISTOR BC549C	2	Q202,203
85	30-2085-2	TRANSISTOR BC559B	4	Q403,404,405,406
86	30-2090-2	TRANSISTOR BC546B	2	Q409,410
87	30-2096	TRANSISTOR BC556A	2	Q407,408
88	30-3015	IC HA1156	1	IC201
89	30-3017	IC HA1137	1	IC101
90	30-3018	IC HA1138	1	IC301
91	31-1061	ROTARY SW SRZ-V086 (12,5)	1	
92	35-2010	FRONT END FB127U	1	
93	19-1083	PCB	1	

90-1082(7060)

1	11-5006	HEAT SINK B	2	
2	11-5017	HEAT SINK	1	
3	16-1/2CP100J	CARBON RES 10 OHM 1/2W +- 5%	4	R649,650,653,654
4	16-1/2CP152J	CARBON RES 1.5K OHM 1/2W +- 5%	4	R615,616,623,624
5	16-1/2CP220J	CARBON RES 22 OHM 1/2W +- 5%	1	R806
6	16-1/2CP221J	CARBON RES 220 OHM 1/2W +- 5%	2	R651,652
7	16-1/2CP5R6J	CARBON RES 5.6 OHM 1/2W +- 5%	1	R801
8	16-1/4CM101J	CARBON RES 100 OHM 1/4W +- 5%	2	R541,542
9	16-1/4CM102J	CARBON RES 1K OHM 1/4W +- 5%	13	R619,620,635,636,655,656,661 662,807,808,809,924,925
10	16-1/4CM103J	CARBON RES 10K OHM 1/4W +- 5%	4	R523,524,903,916
11	16-1/4CM104J	CARBON RES 100K OHM 1/4W +- 5%	5	R529,530,537,538,907
12	16-1/4CM123J	CARBON RES 12K OHM 1/4W +- 5%	1	R904
13	16-1/4CM152J	CARBON RES 1.5K OHM 1/4W +- 5%	6	R607,608,625,626,637,638
14	16-1/4CM153J	CARBON RES 15K OHM 1/4W +- 5%	16	R501,502,519,520,525,526,605, 606,633,634,657,658,659,660, 813,815
15	16-1/4CM154J	CARBON RES 150K OHM 1/4W +- 5%	1	R914
16	16-1/4CM155J	CARBON RES 1.5M OHM 1/4W +- 5%	2	R527,528
17	16-1/4CM221J	CARBON RES 220 OHM 1/4W +- 5%	1	R811
18	16-1/4CM222J	CARBON RES 2.2K OHM 1/4W +- 5%	4	R645,646,647,648
19	16-1/4CM223J	CARBON RES 22K OHM 1/4W +- 5%	4	R919,920,922,923
20	16-1/4CM224J	CARBON RES 220K OHM 1/4W +- 5%	3	R505,506,912
21	16-1/4CM271J	CARBON RES 270 OHM 1/4W +- 5%	1	R917
22	16-1/4CM272J	CARBON RES 2.7K OHM 1/4W +- 5%	2	R503,504
23	16-1/4CM330J	CARBON RES 33 OHM 1/4W +- 5%	2	R643,644
24	16-1/4CM332J	CARBON RES 3.3K OHM 1/4W +- 5%	2	R926,927
25	16-1/4CM333J	CARBON RES 33K OHM 1/4W +- 5%	7	R609,610,627,628,901,902,905
26	16-1/4CM390J	CARBON RES 39 OHM 1/4W +- 5%	2	R535,536
27	16-1/4CM392J	CARBON RES 3.9K OHM 1/4W +- 5%	10	R509,510,515,516,517,518,531, 532,613,614
28	16-CM393J	CARBON RES 39K OHM 1/4W +- 5%	2	R611,612
29	16-1/4CM470J	CARBON RES 47 OHM 1/4W +- 5%	4	R621,622,631,632
30	16-1/4CM471J	CARBON RES 470 OHM 1/4W +- 5%	1	R814
31	16-1/4CM472J	CARBON RES 4.7K OHM 1/4W +- 5%	4	R539,540,804,805
32	16-1/4CM474J	CARBON RES 470K OHM 1/4W +- 5%	5	R601,602,603,604,812
33	16-1/4CM561J	CARBON RES 560 OHM 1/4W +- 5%	2	R507,508
34	16-1/4CM562J	CARBON RES 5.6K OHM 1/4W +- 5%	4	R513,514,533,534
35	16-1/4CM564J	CARBON RES 560K OHM 1/4W +- 5%	1	R909
36	16-1/4CM683J	CARBON RES 68K OHM 1/4W +- 5%	2	R910,915
37	16-1/4CM821J	CARBON RES 820 OHM 1/4W +- 5%	2	R511,512
38	16-1/4CM822J	CARBON RES 8.2K OHM 1/4W +- 5%	4	R521,522,906,913
39	16-1/4CN182J	CARBON RES 1.8K OHM 1/4W +- 5%	2	R802,803
40	16-1/4CN330J	CARBON RES 33 OHM 1/4W +- 5%	2	R629,630

ITEM	PARTS NO	DESCRIPTION	Q'TY	SYMBOL NO
41	16-¼CN561J	CARBON RES 560 OHM ¼W +-5%	1	R911
42	16-¼CN681J	CARBON RES 680 OHM ¼W +-5%	2	R617, 618
43	16-1A 102J	METAL OXIDE RES 1K OHM 1W +-5%	2	R641, 642
44	16-1A 152J	METAL OXIDE RES 1.5K OHM 1W +-5%	2	R639, 640
45	16-1A 391J	METAL OXIDE RES 390 OHM 1W +-5%	1	R921
46	16-1A 5R6J	METAL OXIDE RES 5.6 OHM 1W +-5%	4	R667-670
47	16-1003	RES MPC 71 0.22 OHM 5W	4	R663-666
48	17-0.63E 107Y	ELEC CAPA 100µf/6.3V +50-10%	4	C509, 510, 904, 905
49	17-0.63E476Y	ELEC CAPA 47µf/6.3V +50-10%	2	C617, 618
50	17-1.6E106Y	ELEC CAPA 10µf/16V +50-10%	8	C517, 518, 525, 526, 529, 530 607, 608
51	17-1.6S227Y	ELEC CAPA 220µf/16V +50-10% (N.P)	1	C903
52	17-2.5E105Y	ELEC CAPA 1µf/25V +50-10%	2	C505, 506
53	17-2.5E106Y	ELEC CAPA 10µf/25V +50-10%	2	C809, 810
54	17-2.5E475Y	ELEC CAPA 4.7µf/25V +75-10%	1	C902
55	17-3.5E106Y	ELEC CAPA 10µf/35V +50-10%	1	C806
56	17-3.5E476Y	ELEC CAPA 47µf/35V +50-10%	1	C805
57	17-5D100D	CER CAPA 10P +-0.5P 50V	4	C511, 512, 623, 624
58	17-5D101M	CER CAPA 100P +-20% 50V	2	C507, 508
59	17-5D102M	CER CAPA 1000P +-20% 50V	6	C615, 616, 631, 632, 635, 636
60	17-5D103M	CER CAPA 0.01µf +-20% 50V	2	C901, 906
61	17-5D104M	CER CAPA 0.1µf +-20% 50V	6	C613, 614, 643x2, 644x2
62	17-5D220K	CER CAPA 22P +-10% 50V	4	C527, 528, 807, 808
63	17-5D221M	CER CAPA 220P +-20% 50V	4	C609, 610, 621, 622
64	17-5D332M	CER CAPA 0.0033µf +-20% 50V	4	C637-640
65	17-5D821M	CER CAPA 820P +-20% 50V	2	C510, 502
66	17-5E476Y	ELEC CAPA 47µf/50V +50-10%	5	C625, 626, 629, 633, 634
67	17-5F102J	MYLAR CAPA 0.001µf +-5% 50V	4	C519, 520, 645, 646
68	17-5F104J	MYLAR CAPA 0.1µf +-50% 50V	4	C641, 642, 627, 628
69	17-5F222J	MYLAR CAPA 0.0022µf +-5% 50V	2	C619, 620
70	17-5F224J	MYLAR CAPA 0.22µf +-5% 50V	2	C503, 504
71	17-5F394J	MYLAR CAPA 0.39µf +-5% 50V	2	C605, 606
72	17-5F472J	MYLAR CAPA 0.0047µf +-5% 50V	2	C601, 602
73	17-5F473J	MYLAR CAPA 0.047µf +-5% 50V	4	C521-524
74	17-5F474J	MYLAR CAPA 0.47µf +-5% 50V	2	C603, 604
75	19-1082	P.C.B. (Main Amp)	1	
76	29-1036-1	AIR COIL 3.3µH	2	L601, 602
77	29-4028	VOLUME CONTROL GM70E-50KB-2	2	VR503, 504
78	29-4071	VOLUME CONTROL GM70E-50KMN-2	1	VR501
79	29-4072	VOLUME CONTROL GM80E-50KB-2	1	VR502
80	30-1016	ZENER DIODE 23V 0.5W	5	D601, 602, 619, 620, 805
81	30-1017-1	DIODE G3B	4	D801-804
82	30-1019	DIODE BAW62	14	D603-614, 901, 902
83	30-2080	TRANSISTOR 2SD315E	1	Q801
84	30-2082	TRANSISTOR BD140	4	Q609, 610, 804, 905
85	30-2083	TRANSISTOR BD139	2	Q901, 906
86	30-2084-3	TRANSISTOR BC549C	2	Q607, 608
87	30-2085-2	TRANSISTOR BC559B	4	Q601-604
88	30-2086	TRANSISTOR 2SB536M	2	Q619, 620
89	30-2087	TRANSISTOR 2SD381M	2	Q617, 618
90	30-2090-2	TRANSISTOR BC546B	16	Q501, 502, 505-508, 605, 606 613, 614, 802, 902-904, 907, 908
91	30-2096	TRANSISTOR BC556A	7	Q503, 504, 509, 510, 615, 616 803
92	31-1062T	PUSH S.W. 5KEY SUE-54	1	
90-2082(7045)				
1	16-¼CM101J	CARBON RES 100 OHM ¼W +-5%	2	R541, 542
2	16-¼CM102J	CARBON RES 1K OHM ¼W +-5%	12	R619, 620, 635, 655, 656, 661, 662, 807-809, 706
3	16-¼CM103J	CARBON RES 10K OHM ¼W +-5%	2	R523, 524
4	16-¼CM 104J	CARBON RES 100K OHM ¼W +-5%	6	R529, 530, 537, 538, 703, 705
5	16-¼CM152J	CARBON RES 1.5K OHM ¼W +-5%	6	R607, 608, 625, 626, 637, 638
6	16-¼CM153J	CARBON RES 15K OHM ¼W +-5%	16	R501, 502, 519, 520, 525, 526, 605, 606, 633, 634, 657-660, 813, 815
7	16-¼CM155J	CARBON RES 1.5M OHM ¼W +-5%	2	R527, 528
8	16-¼CM183J	CARBON RES 18K OHM ¼W +-5%	0	
9	16-¼CM221J	CARBON RES 220 OHM ¼W +-5%	1	R811
10	16-¼CM222J	CARBON RES 2.2K OHM ¼W +-5%	4	R645-648
11	16-¼CM223J	CARBON RES 22K OHM ¼W +-5%	2	R701, 702
12	16-¼CM224J	CARBON RES 220K OHM ¼W +-5%	2	R505, 506

EM	PARTS NO	DESCRIPTION	Q'TY	SYMBOL NO
85	30-2096	TRANSISTOR BC556A	7	606, 613, 614, 802, 701, 702 Q503, 504, 509, 510, 615, 616, 803
86	31-1062T	PUSH SW SKY SUE-54	1	

THER (7045-7060)

1	16-¼CM104J	CARBON RES 100K OHM ¼W+-5%	2	R439, 440
2	16-¼CM394J	CARBON RES 390K OHM ¼W +-5%	2	R441, 442
3	19-1047	PCB FOR MAININ PREOUT	1	
4	19-1064	LED PCB	1	
5	19-1065	LED PCB	1	
6	19-1077	PCB FOR POWER TRANSISTOR	2	
7	30-1026	LED φ YELLOW	5	
8	30-1027	LED 3φ GREEN	1	
9	18-1016-1	BALUN	1	
10	29-5005	AM ANT COIL	1	LA101
11	31-1002	SWITCH 6P	2	
12	31-1021	SPEAKER ROTARY SW	1	
13	31-1039	POWER SW	1	
14	31-1025T	PUSH SW 2 KEY	1	
15	31-2007	LAMP 150MA	3	
16	31-2014	LAMP FUSE TYPE	2	
17	35-1011	TUMING METER	1	
18	35-1012	SIGNAL METER	1	
19	35-3002	RELAY SD 205P	1	(7060)
20	11-5012	HEATSINK	2	

DIFFERENT SECTION (7045, 7060) * 7045/7060

EM	PARTS NO	DESCRIPTION	EC	SC	IL	UK	AS	UL	SI	HK	AG	BL	US	CSA
21	11-3022	Fuse Clip		4										
22	11-3026	Fuse Holder(Lug Type)		1										
23	11-3026	Lug	2	3	3	3	3	2	2	2	2	2		
24	11-3027	Lug Board 1L 2P	2	1	2	2	2	2	1	1	2	2		
25	11-3028	Lug Board 1L 6P							1	1				
26	11-8056-1	Back Panel W/O AC Outlet	1	1		1	1				1	1		
27	11-8056	Back Panel W/ AC Outlet			1			1	1	1				
28	12-1029	Connector W/Nut	1	1	1	1	1				1	1		
29	12-1032	Connector						1	1	1				
30	12-2006	AC Outlet Socket			2			2	2	2				
31	13-4026	Insulating Tube 80 mm							1	1				
32	13-4026	Insulating Tube 50 mm	1	1	1	1	1	1	1		1	1		
33	14-5003	Cord Stopper 4N4	1					1	1	1	1	1		
34	14-5005	Cord Stopper 5N4		1	1	1	1							
35	14-5013	Power Cord (AS)					1							
36	14-5014	Power Cord (UL-1)						1	1	1				
37	14-5020	Power Cord (CEE2)	1								1	1		
38	14-5024	Power Cord (CEE6)		1	1									
39	14-5025	Power Cord (BS)				1								
40	17-2001	Ceramir Capa ECK-DHS472MD	2	2	2				2	2	2	2		
41	17-2003	Ceramir Capa ECK-DEL472ZE						2						
42	17-2004	Ceramir Capa ECK-DGS472MD4				2	2							
43	29-2028	Power Transformer (Changeable)							1	1				
44	29-2028-1	Power Transformer (117V)						1						
45	29-2028-2	Power Transformer (240V)				1	1							
46	29-2028-3	Power Transformer (220V)	1	1	1						1	1		
47	29-2028-4	Power Transformer (117V)						CSA 1						
48	32-2001	Fuse Holder						3/1	3/1	3/1			0/1	
49	32-2003	Fuse Holder	3/1	3/1	3/1	3/1	3/1				3/1	3/1		
50	32-2005	Fuse Holder												1/1
51	32-16301SS	Fuse 6.3 AT SEMKO			4/4									
52	32-11001SS	Fuse 1AT SEMKO			2/2									
53	32-12001SS	Fuse 2AT SEMKO	2/2	2/0	2/2	2/2	2/2				2/2	2/2		
54	32-12001UT	Fuse 2AUL SEMKO												
55	32-14001UT	Fuse 4AUL						3/2	4/0	4/0				
56	32-14001SS	Fuse 4AT SEMKO	4/0	4/0	4/0	4/0	4/0				4/0	4/0		